

1. Report No. FHWA/TX-14/9-1001-4		2. Government Accession No.		3. Recipient's Catalog No.	
4. Title and Subtitle TRAFFIC CONTROL DEVICE EVALUATION PROGRAM: TECHNICAL REPORT				5. Report Date Published: January 2014	
				6. Performing Organization Code	
7. Author(s) Paul J. Carlson, Michael P. Pratt, Laura L. Higgins, and Alicia A. Nelson				8. Performing Organization Report No. Report 9-1001-4	
9. Performing Organization Name and Address Texas A&M Transportation Institute College Station, Texas 77843-3135				10. Work Unit No. (TRAIS)	
				11. Contract or Grant No. Project 9-1001	
12. Sponsoring Agency Name and Address Texas Department of Transportation 125 East 11th St. Austin, Texas 78701-2483				13. Type of Report and Period Covered Technical Report: September 2009–August 2013	
				14. Sponsoring Agency Code	
15. Supplementary Notes Project performed in cooperation with the Texas Department of Transportation and the Federal Highway Administration. Project Title: Traffic Control Device Evaluation Program URL: http://tti.tamu.edu/documents/9-1001-4.pdf					
16. Abstract This project was established to provide a means of conducting small scale research activities on an as-needed basis so that the results could be available within months of starting the specific research. This report summarizes the research activities that were conducted between September 2009 and August 2013. Researchers evaluated bridge clearance signing and visibility; incorporating multiple-curve processing capabilities into the GPS method for setting advisory speeds; and guidelines for sign sheeting material for rural applications.					
17. Key Words Bridge Clearance Signing, Sign Legibility Distance, Discomfort and Disability Glare, Retroreflectivity, Detection Distance, Signal Phasing and Queuing, Simulation			18. Distribution Statement No restrictions. This document is available to the public through NTIS: National Technical Information Service Alexandria, Virginia 22312 http://www.ntis.gov		
19. Security Classif. (of this report) Unclassified		20. Security Classif. (of this page) Unclassified		21. No. of Pages 120	22. Price

**TRAFFIC CONTROL DEVICE EVALUATION PROGRAM:
TECHNICAL REPORT**

by

Paul J. Carlson, Ph.D., P.E.
Research Engineer
Texas A&M Transportation Institute

Michael P. Pratt, P.E.
Assistant Research Engineer
Texas A&M Transportation Institute

Laura L. Higgins
Associate Research Scientist
Texas A&M Transportation Institute

and

Alicia A. Nelson
Associate Research Specialist
Texas A&M Transportation Institute

Report 9-1001-4
Project 9-1001
Project Title: Traffic Control Device Evaluation Program

Performed in cooperation with the
Texas Department of Transportation
and the
Federal Highway Administration

Published: January 2014

TEXAS A&M TRANSPORTATION INSTITUTE
College Station, Texas 77843-3135

DISCLAIMER

This research was performed in cooperation with the Texas Department of Transportation (TxDOT) and the Federal Highway Administration (FHWA). The contents of this report reflect the views of the authors, who are responsible for the facts and the accuracy of the data presented herein. The contents do not necessarily reflect the official view or policies of the FHWA or TxDOT. This report does not constitute a standard, specification, or regulation, and its contents are not intended for construction, bidding, or permit purposes. In addition, the above listed agencies assume no liability for its contents or use thereof.

The United States Government and the State of Texas do not endorse products or manufacturers. Trade or manufacturers' names appear herein solely because they are considered essential to the object of this report.

The engineer in charge of the project was Paul J. Carlson, Ph.D., P.E. (Texas, #78550).

ACKNOWLEDGMENTS

This project was conducted in cooperation with TxDOT and FHWA. The authors thank the project director, Michael Chacon of the TxDOT Traffic Operations Division, for providing guidance and expertise on this project. Wade Odell of the TxDOT Research and Technology Implementation Office was the research engineer. The other members of the project monitoring committee included the following project advisors:

- Ricardo Castañeda, TxDOT San Antonio District.
- John Gianotti, TxDOT San Antonio District.
- Carlos Ibarra, TxDOT Atlanta District.
- Sylvester Onwas, TxDOT Houston District.
- Ismael Soto, TxDOT Corpus Christi District.
- Roy Wright, TxDOT Abilene District.

TABLE OF CONTENTS

	Page
List of Figures	viii
List of Tables	ix
Chapter 1. Bridge Clearance Signing	1
Phase I–Commercial Driver Surveys.....	2
Experimental Design.....	4
Phase II–Simulator Testing.....	10
Conclusions and Recommendations	37
Chapter 2. Incorporation of Multiple-Curve Processing Capability into the GPS Method for Setting Advisory Speeds	41
Introduction.....	41
Methodology.....	42
Implementation Procedure	47
Results.....	52
Chapter 3. Guidelines for Sign Sheeting Material for Rural Applications	57
Introduction.....	57
Objective.....	58
Impacts of Sign Brightness	58
Study Design.....	62
Procedure	63
Data Cleaning and Reduction	65
Data Analysis.....	66
Analysis of Sign Legibility Distance	71
Discussion of Results.....	73
Recommendations.....	75
Appendix A. District Feedback Form	77
Appendix B. Participant Instructions	81
Appendix C. Participant Data Sheets	85
Appendix D. Distance to Lane Change	103
References	109

LIST OF FIGURES

	Page
Figure 1. Example of a Low-Clearance Bridge That is Not Visible to the Driver at the Exit Decision Point.....	1
Figure 2. Expert Panel Sign Alternatives.....	3
Figure 3. Entrance Ramp Sign Alternatives.....	3
Figure 4. Signs for Survey Evaluation.....	4
Figure 5. Survey Graphic Example.....	5
Figure 6. Screenshots of Simulation.....	19
Figure 7. Example of Frontage Road Scenario.....	19
Figure 8. Example of Freeway Scenario.....	20
Figure 9. Average Lane Change Distance from the Test Sign.....	29
Figure 10. Detailed Data File Settings.....	47
Figure 11. TCAS Controls for In-Field Analysis.....	48
Figure 12. Calibration Parameters for TCAS In-Office Analysis.....	49
Figure 13. TCAS Curve Data Source Control for In-Office Analysis.....	50
Figure 14. Warning Message for Data Files.....	50
Figure 15. TCAS Data File and Batch-Process Controls for In-Office Analysis.....	51
Figure 16. High Beam Usage by Vehicles per Hour.....	60
Figure 17. Detection Targets.....	63
Figure 18. Texas A&M Riverside Campus.....	64
Figure 19. Detection Distance for Detection Targets.....	68
Figure 20. Detection Distance for Three Objects by Object Location.....	69
Figure 21. Detection Distance for Three Objects by Drivers' Age.....	69

LIST OF TABLES

	Page
Table 1. Comprehension Results for Vertical Clearance Warning Signs on Freeway, Phase I.....	7
Table 2. Comprehension Results for Vertical Clearance Warning Signs on Frontage Road, Phase I.....	8
Table 3. Responses to Follow-up Questions: Vertical Clearance Warning Signs on Freeway, Phase I.....	9
Table 4. Responses to Follow-up Questions: Vertical Clearance Warning Signs on Frontage Road, Phase I.....	10
Table 5. Proposed Test Signs for Phase II (Part 1).....	11
Table 6. Proposed Test Signs for Phase II (Part 2).....	12
Table 7. TxDOT District Signing Approaches for Warning of Upcoming Low Bridge.....	13
Table 8. TxDOT District Feedback on Proposed Test Signs for Phase II–Freeway Signs 1–4.....	16
Table 9. TxDOT District Feedback on Proposed Test Signs for Phase II–Freeway Signs 5–8.....	17
Table 10. TxDOT District Feedback on Proposed Test Signs for Phase II–Frontage Road Signs 9–10.....	18
Table 11. Final Test Signs and Treatments for Simulator Study.....	22
Table 12. Various Group Orders of Treatments.....	23
Table 13. Decision-Making Data (Correct, Unnecessary, and Incorrect) with First Filter.....	25
Table 14. Subset of Decision Making Data (Correct, Unnecessary, and Incorrect) with Second Filter.....	26
Table 15. Correct Maneuvers by Sign (Clearance and No-Clearance Scenarios) with First Filter.....	27
Table 16. Subset of Correct Maneuvers by Sign (Clearance and No-Clearance Scenarios) with Second Filter.....	27
Table 17. Confidence Ratings for all Correct Maneuvers (Correct plus Unnecessary).....	28
Table 18. Confidence Ratings for All Incorrect Maneuvers.....	28
Table 19. Follow-Up Question “According to the Sign, How Far Away Is the Low Clearance?” (For Freeway Test Signs Only).....	30
Table 20. Follow-Up Question “If You Needed to Exit Because of Your Truck’s Height, Would You Have Another Opportunity to Exit the Highway before the Low Clearance?” (For Freeway Test Signs Only).....	31
Table 21. Follow-up Question “Was the Height Limit on the Sign for the Frontage Road or for the Freeway?” (For Frontage Road Test Signs Only).....	32
Table 22. Summary Results for Frontage Road Signs.....	36
Table 23. Summary Results for Freeway Signs.....	37
Table 24. TRAMS Data File Contents.....	44
Table 25. Validation Data set Description.....	52
Table 26. Summary of Detection Distance in Each Category.....	67
Table 27. Analysis of Variance Results for Detection Distance.....	70
Table 28. Summary of Legibility Distance in Each Category.....	72
Table 29. Analysis of Variance Results for Legibility Distance.....	73

CHAPTER 1. BRIDGE CLEARANCE SIGNING

TxDOT personnel were concerned that there are times when a bridge clearance sign is needed to identify a bridge that is currently not visible to a driver due to distance and/or that is beyond another, higher bridge that is within the view of the driver. If the last available highway exit that will allow a driver to avoid an upcoming low bridge/clearance is prior to the nearer, higher bridge, then the vertical clearance warning sign for the second, lower bridge needs to convey this situation to the driver. [Figure 1](#) shows an illustration of this situation.

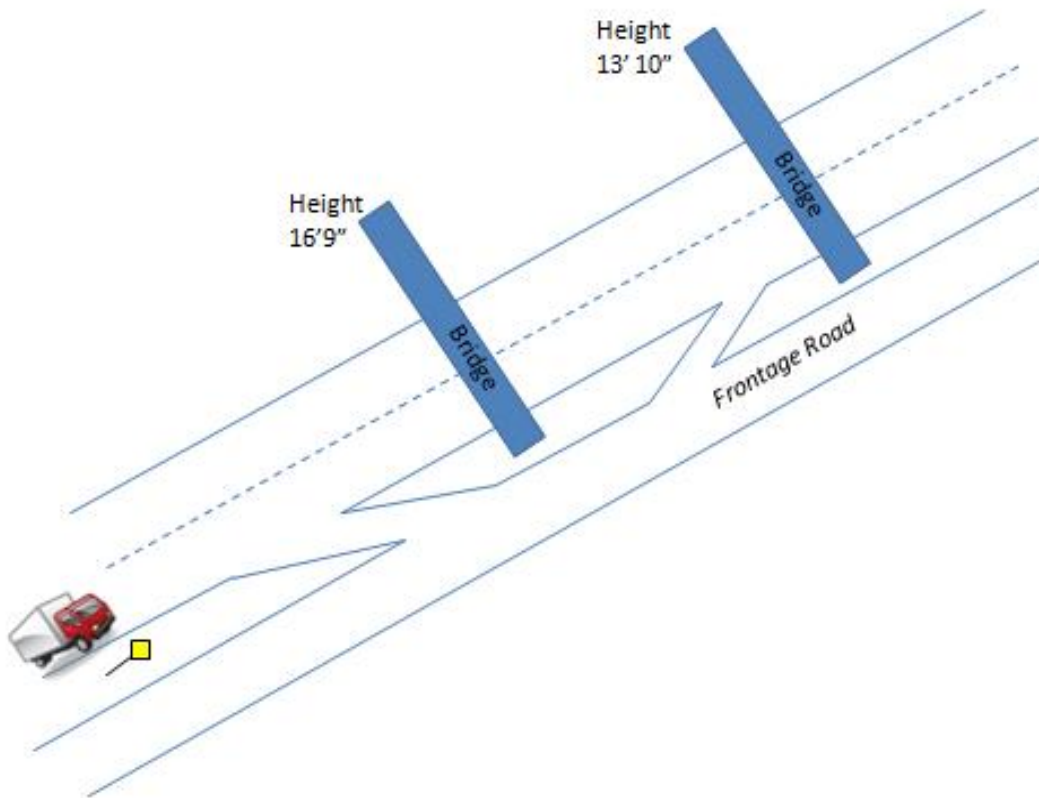

Figure 1. Example of a Low-Clearance Bridge That is Not Visible to the Driver at the Exit Decision Point.

Researchers were tasked with identifying signing that would communicate to drivers of large and/or high-profile vehicles that they need to exit due to height restrictions at the second bridge. Additionally, the research team considered signing options for use on the frontage road,

to discourage vehicles from entering or re-entering the highway at the immediate downstream entrance ramp before the height restriction.

This study was conducted in two phases. In Phase I, researchers developed a list of exit warning sign options based on information elements considered critical to a driver's decision to exit at the appropriate point on the roadway to avoid a too-low vertical clearance. Phase I culminated in a survey of commercial truck drivers to test the comprehensibility of the developed sign options. In Phase II, the researchers modified the original list of signs based on the Phase I results as well as input from TxDOT District Engineers. The modified list of sign designs was then tested with commercial drivers using TTI's desktop driving simulator.

PHASE I—COMMERCIAL DRIVER SURVEYS

To begin the process of identifying appropriate signing for the height restriction concern, an expert panel of researchers involved in signing and human factors areas was assembled. During the panel meetings, these researchers discussed alternative information elements that would need to be included in the sign and identified possible sign layouts. The following are the critical information elements that the panel identified:

- Lowest bridge height.
- Distance or location information.
- Action statement.

Although the researchers believed that all three of these information elements were important to drivers, there was also discussion that not all of these elements may be needed to convey the critical point to a driver. To illustrate this point, [Figure 2](#) shows the information combinations that were created within sign designs for use on the highway. Note that in some cases a distance is used on the sign without an action (*EXIT NOW*) and vice versa. Researchers believed that it may be possible for drivers to infer the need to exit without both of these information elements. However, in all signing alternatives the panel felt that the height information was not sufficient to ensure the drivers' correct action.

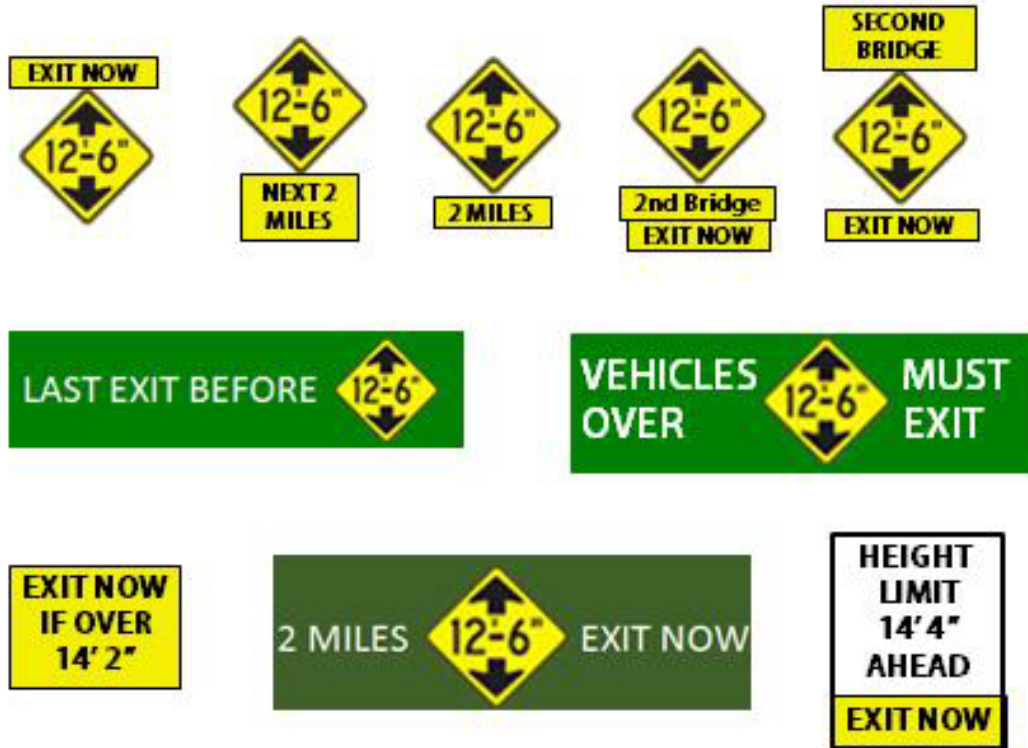

Figure 2. Expert Panel Sign Alternatives.

To address the concern of vehicles not using a specific entrance ramp to enter or reenter the highway, researchers developed two signing alternatives. The primary information difference for this signing as compared to typical bridge height signing was that the sign needed to be understood to only apply to the ramp/freeway lanes and not to the frontage road. Figure 3 shows the two sign alternatives that were developed for this application.



Figure 3. Entrance Ramp Sign Alternatives.

Once this collection of signs had been identified, researchers narrowed the group of alternatives that would be evaluated in a human factors study based on the fact that multiple designs contained the same information elements. Figure 4 shows the group of six signs that were evaluated for highway use during the Phase I human factors study. Both of the ramp sign designs were also evaluated.



Figure 4. Signs for Survey Evaluation.

EXPERIMENTAL DESIGN

Once the signing alternatives had been identified, the researchers developed a human factors survey experimental plan to evaluate the signs for driver comprehension and preference. During the survey, the group focused on recruiting commercial drivers since the latter is the primary audience for bridge height information signing.

Comprehension

Each of the sign alternatives was displayed as a typical highway sign within a picture showing a highway section with an exit just ahead of the driver’s current location and a bridge shown in the near distance of the exit. The bridge height given on the structure using MUTCD placard sign W12-3T was the bridge height for the nearer structure and therefore did not match the warning sign being evaluated. Each of the signs evaluated in this survey displayed different

heights and distances for the downstream bridge to provide greater variety within the survey, thereby reducing redundancy to the participant. [Figure 5](#) shows an example of the graphics used in this survey.



Figure 5. Survey Graphic Example.

Each participant viewed four signs to determine comprehension. This included three main route signs and one ramp sign. For each of these signs, participants were asked the following questions.

- What information is this sign trying to tell drivers?
- As a truck driver (remember your truck is 15 feet in height), what would you do if you saw this sign? Why?

Preference

At the beginning of the preference section, the survey administrator showed the participants a diagram similar to that in [Figure 1](#). When showing this diagram, the survey administrator explained to the participants the intent of the sign information to identify the height of a downstream bridge and that they will need to exit now due to height restrictions. Thereby, researchers were able to determine the participants' preferences through the use of several

Yes/No questions as “Does the sign provide you with the following information?” For the main line signs, the following information unit queries were used. For each of these queries, participants selected all of the signs that they believed provided that bit of information and selected which sign they preferred for that information from the group of alternatives being evaluated.

- There is no exit between the bridges.
- There is no exit before the (height shown on sign) second bridge.
- You need to exit now if your truck is taller than (height shown on sign).
- The information on the sign shown is not for the first bridge.

Researchers used a second diagram to illustrate that the vehicle is now traveling on the frontage road as it approached an entrance onto the highway. Again, Yes/No questions were asked to identify if the given sign provides information on the following points and to determine the participants’ sign preference:

- You should continue on the frontage road.
- You cannot pass under a bridge on the highway.

Finally, participants were asked if they have any suggestions to improve the signing options they viewed during the survey.

Participant Recruitment







Researchers recruited only commercial truck drivers for this survey. These drivers were required to have a valid driver’s license and be over 18 years of age. During this survey effort, the research team recruited a total of 120 participants in two locations. The first recruitment site was in Bryan/College Station, TX on Texas Highway 6 so researchers can have easy access during the initial data collection and survey revision process. Secondly, the research team traveled to a truck stop near San Antonio, TX on Interstate 35 to recruit a more robust population of long-haul, experienced truck drivers.

Results

Comprehension. Of the six highway exit warning signs tested, Sign B was interpreted correctly by the largest percentage of participants, as indicated by the driving actions each participant said he/she would take based on the sign and his/her answers to follow-up questions



(see Table 1). The most common misunderstanding of those who took the correct action was that the height was an indication for the bridge immediately ahead of them. However, this did not deter them from exiting as indicated.

Table 1. Comprehension Results for Vertical Clearance Warning Signs on Freeway, Phase I.

Sign	Correct Action		Wrong Action		Do Not Know
	All Correct	Didn't Fully Understand Message	Believed Was Another Exit	Height Was on Exit/Frontage or Other	
A  2 MILES	68%	7%	18%	3%	3%
B  2ND BRIDGE EXIT NOW	92%	3%	3%	2%	0
C  EXIT NOW	58%	32%	3%	0	7%
D 	70%	27%	2%	2%	0
E 	67%	28%	2%	3%	0
F  Exit Now	67%	27%	0	7%	0







Of the two frontage road/ramp signs viewed, more drivers interpreted R2 correctly than R1, indicating that vehicles over the specified height should not use the entrance ramp (see Table 2).

Table 2. Comprehension Results for Vertical Clearance Warning Signs on Frontage Road, Phase I.

Sign	Correct Action		Wrong Action
	All Correct	Didn't Fully Understand Message	
 <p>R1</p>	43%	48%	8%
 <p>R2</p>	70%	25%	5%



Preference. Participant preference for each of the sign types was measured by the answers that participants gave to questions about the types of information that each of the signs provided. [Table 3](#) shows the number of respondents who indicated that each of the test signs provided the information listed.

Table 3. Responses to Follow-up Questions: Vertical Clearance Warning Signs on Freeway, Phase I.

Signs	Does Sign Provide the Following Information? Number of Participants Answering "Yes"			
	No Exit Between Bridges	There Is No Exit Before the 2nd Bridge	You Need to Exit Now If Your Truck Is Taller than Sign Dimension	The Information On the Sign Shown Is Not for the First Bridge
 A 2 MILES	24	23	34	33
 B 2ND BRIDGE EXIT NOW	50	53	72	76
 C EXIT NOW	40	27	84	16
 D	38	28	93	17
 E	65	47	60	26
 F	44	39	77	36
None of the Signs	14	15	0	12
Participant Preference (Sign Letter)	E	B	D	B

Believing that the most critical information component within this message is whether drivers understand this is their last opportunity to exit before the height restriction given, the first two of the questions above are the most critical. Signs E and B resulted in the highest number of correct responses to those questions. However, given the comprehension results shown in [Table 1](#), Sign B tested best overall.

Table 4. Responses to Follow-up Questions: Vertical Clearance Warning Signs on Frontage Road, Phase I.

Signs	Does Sign Provide the Following Information? Number of Participants Answering “Yes”	
	You Should Continue on the Frontage Road	You Cannot Pass Under a Bridge on the Highway
 <p>R1</p>	56	23
 <p>R2</p>	78	18
None of the Signs	15	73
Preference (Sign Letter)	R2	R2

Neither sign for use on the ramp clearly conveyed to the drivers that the height restriction was in place because of an overpass on the highway. However, they were able to understand the action they needed to take (i.e., continue on the frontage road).

PHASE II–SIMULATOR TESTING

The research team began Phase II by reviewing the sign options that were tested in the commercial driver survey. Based on survey scores (specifically, the percentage of survey participants who had correctly interpreted each of the tested signs) and conventions regarding warning signs, the team made initial recommendations to (a) keep, (b) revise, or (c) discard each of the originally tested signs in preparation for a second phase of testing. In place of the discarded sign designs, the team suggested other designs that had not previously been tested in the Phase I survey. [Table 5](#) and [Table 6](#) show the signs that the research team initially proposed for testing in Phase II.

Table 5. Proposed Test Signs for Phase II (Part 1).













Sign Tested in Phase I Survey	Proposed Sign for Phase II Simulator Testing	Comments
<p>A</p>  <p>2 MILES</p>	<p>Same sign</p>	<p>MUTCD standard</p>
<p>B</p>  <p>2ND BRIDGE EXIT NOW</p>	<p>Same sign</p>	<p>Highest scoring sign from Phase I survey</p>
<p>C</p> 	<p>n/a</p>	<p>Deleted; scored low in Phase I survey</p>
<p>D</p> 	<p>Same sign</p>	<p>Performed comparably to MUTCD standard in Phase I survey</p>
<p>E</p> 		<p>Eliminated guide sign component to mimic MUTCD standard</p>
<p>F</p> 		<p>Eliminated guide sign component to mimic MUTCD standard and Sign B</p>

Table 6. Proposed Test Signs for Phase II (Part 2).

Sign Tested in Phase I Survey	Proposed Sign for Phase II Simulator Testing	Comments
 R1 RAMP	 ON FREEWAY	Frontage road sign; replaced <i>RAMP</i> with <i>ON FREEWAY</i> to clarify where (on which road) the low clearance is.
 R2 OVER 13'-2"	 ON FREEWAY	Frontage road sign; replaced <i>RAMP</i> with <i>ON FREEWAY</i> to clarify where (on which road) the low clearance is.
n/a		Not tested in Phase I; proposed for testing in Phase II.
n/a	 NEXT 5 MILES	Not tested in Phase I; proposed for testing in Phase II.

This list of signs was e-mailed to TxDOT district engineers for feedback; representatives from 18 districts responded. The feedback form described the scenario being tested (low clearance sign indicating the need to exit in advance of an upcoming bridge that is not yet within view) and asked for feedback regarding their districts’ current or potential signing practices for this situation, as well as on the proposed sign designs for testing in Phase II.

Question 1 asked: “What does/would your district do in the case that the low bridge is not the first bridge a driver would approach on a freeway, yet the only available exit to avoid the low bridge is prior to a taller bridge that is in view?” Three answer choices were provided, along with space for comments. [Table 7](#) summarizes the responses to Question 1.

Table 7. TxDOT District Signing Approaches for Warning of Upcoming Low Bridge.

Answer Choice	Number of Responses
We use (or would use) the W12-2 sign and supplemental plaque as shown above for the situation described	11
We use (or would use) an additional or different sign as follows (see below under ‘b’)	7
Other—please describe	3

*A few districts selected more than one answer choice, which were all counted in the response numbers.

Comments from the district representatives regarding signing practices and preferences included the following:

- “We are using the W12-2 sign and supplemental plaque (as shown in the first answer choice) now for this type of situation.”
- “We would use the standard *LOW BRIDGE CLEARANCE* from the MUTCD with the appropriate distance plaque and consider supplementing it with a *USE NEXT EXIT* type of plaque.”
- “We use the W12-2 without the plaque and place it in advance of the last exit available to the drivers.”
- “[We would use] *LOW CLEARANCE BRIDGE 12' 6" 2 miles*, and similar additional signs to make them *EXIT* at the next ramp.”
- “We would place an assembly with a W12-2 and an *EXIT NOW* plaque in advance of the exit ramp necessary to avoid this clearance.”
- “We have two signs installed to advise the traveling public of the vertical clearance. The first sign is an advance warning sign, W12-2 with a supplemental plaque (W12-2TP *LOW CLEARANCE*) and the second sign located at the site location is the W12-2A *CLEARANCE* sign.
- “We would like to give more information to the driver. I would suggest the W12-2 with the W12-2Tp *LOW CLEARANCE* and the *EXIT NOW*.”
- “We could also consider developing a special sign combining the message into one sign panel.”
- “We would use a distance plaque below the clearance sign to inform traffic prior to the taller structure and install before the last exit ramp.”

- “Additional to the above-referenced signs, we have the advance warning signs (W12-4T) to advise the traveling public what route to take as a detour.”
- “We primarily show the lower clearance of the multiple structures in advance of the exit. We also place a clearance sign on the frontage road prior to the entrance ramp.”

Question 2 asked “How does your district approach informing the driver where they can return to the freeway, after they’ve exited to avoid a low clearance?” Most of the responding districts do not currently provide signing for this situation. Several of these districts do not have a low-clearance situation in their jurisdictions. Other comments from districts that do not currently sign for this scenario included the following:

- “In most of our areas our frontage roads are adjacent to the main lanes and drivers have a view of the structure and clearance signs and are able to tell when they pass the low signed structure and usually access the very next ramp after the low structure.”
- “We have very few *LOW CLEARANCE* bridges in our District and normally put the appropriate sign to inform them to use the next exit. Once we get past that point they are free to enter back in. We don’t sign for a confirmation of proper vertical clearance ahead. We only sign for the restricted clearance ahead. In other words, if you don’t see a warning sign, then you are okay.”

Comments from districts that currently provide signing to guide drivers back onto the highway following a low vertical clearance included the following:

- “We use *LOW CLEARANCE* route markers with arrows.”
- “We use signs to route the oversized loads around and back on the freeway that resembles a detour route.”
- “I think we would need to sign at the entrance ramp before the low clearance structure to instruct over-height traffic to stay on the service road, and then an additional sign at the next on-ramp where it is ok for them to return to the main lanes.”
- “We place a *CLEARANCE* sign on the frontage road prior to the entrance ramp.”
- “We would place supplemental signing on frontage road directing traffic back to main lanes of travel.”
- “Additional signing would be needed to guide drivers with these loads once on the frontage road.

- On the Exit Ramp–sign assembly with a W12-2 and a *STAY ON FEEDER* plaque on the exit ramp if the entrance ramp leading to the limiting clearance bridge is immediately downstream of the exit ramp. We wouldn't want them to enter the facility and encounter the bridge for which we were directing them to exit in the first place.
- On the Frontage Road in Advance of the Entrance Ramp–assembly with a sign saying *NO TRUCKS OVER X' Y'* along with a diagonal arrow panel on the frontage road in advance of the entrance ramp to warn of the bridge clearance downstream of the entrance ramp.
- On the Frontage Road at the end of the Exit Ramp–assembly with a W12-2 and an *X MILES* plaque on the frontage road at the end of the exit ramp to inform drivers with high loads of the distance they will travel before they can get back on the facility.
- On the Frontage Road in Advance of Upcoming Clearance Issues Along the Frontage Road–Currently the TMUTCD calls for a W12-2 to be placed in advance of a point at which the vehicle can detour upstream of the bridge. In addition to this, we should also place an *X MILES* and *ON FEEDER* plaque to inform the driver that the clearance will occur on the feeder.”

Question 3 presented the table of proposed sign designs and asked “Are there any of these signs you would eliminate from consideration, and why?” [Table 8](#) through [Table 10](#) summarize the feedback from the district representatives about each of the proposed signs.

Table 8. TxDOT District Feedback on Proposed Test Signs for Phase II–Freeway Signs 1–4.





	Proposed Test Sign	Feedback from Districts	Included in Testing?
1		<p>Nearly all of the responding districts were in favor of testing this sign (MUTCD W12-2 plus distance plaque). The most frequent criticism of this sign option was that it does not provide enough information to the driver.</p>	<p>Yes</p>
2		<p>District feedback was mixed regarding the two supplemental plaques. Some respondents commented that the text size on the plaques would be too small for drivers to read, that the sign includes too much information to process at a glance, and/or that the “2nd Bridge” designation could be confusing if only one bridge is visible. Others thought the more detailed information could be helpful to the driver.</p>	<p>Yes</p>
3		<p>Most of the district representatives favored this sign. Criticisms from some of the districts focused on the two plaques; several commented that the <i>EXIT NOW</i> plaque would provide sufficient information without the addition of the distance plaque.</p>	<p>Yes</p>
4		<p>Most of the responding districts were not in favor of using this sign in its current format. Criticisms included the square shape (more consistent with a regulatory sign than a warning sign) and a perceived lack of clarity in the message regarding the clearance limitation (e.g., vertical vs. width). This sign was modified to a diamond warning sign for testing, retaining the text.</p>	<p>Modified to diamond shape warning sign</p>

Table 9. TxDOT District Feedback on Proposed Test Signs for Phase II–Freeway Signs 5–8.







	Proposed Test Sign	Feedback from Districts	Included in Testing?
5		<p>Several district representatives expressed concern that the non-conventional arrangement (with plaques above and below the warning sign) might be difficult for drivers to read quickly and comprehend. One respondent commented that the arrangement would be a difficult installation, particularly in high wind areas.</p>	Yes
6		<p>Based on feedback, this proposed sign was not included in the simulator testing. The concern expressed most frequently was that the <i>NEXT 5 MILES</i> plaque does not provide the driver information on where to exit the highway.</p>	No
7		<p>This sign design drew mixed responses, with some district representatives feeling it could be a good alternative to the standard warning sign and others concerned that it contains too much information and would be too large a sign. Initial pilot testing of this sign in the simulated driving environment indicated that test participants could not reliably read this sign during the available viewing time (after the sign came into view but before they passed it). This design was ultimately eliminated from Phase II testing for that reason.</p>	No
8		<p>Based on feedback from the District representatives, this sign was eliminated from Phase II testing. Respondents did not like the use of a regulatory-type sign as a warning, and several stated that they prefer to post a sign for each bridge, rather than for all bridges within a stated distance.</p>	No

Table 10. TxDOT District Feedback on Proposed Test Signs for Phase II–Frontage Road Signs 9–10.

	Proposed Test Sign	Feedback from Districts	Included in Testing?
9		<p>Some respondents expressed concern that drivers might misinterpret the <i>ON FREEWAY</i> plaque on this sign as meaning that they should enter the freeway to avoid the low clearance. Others felt that this sign successfully conveyed the message that the low clearance was on the freeway (so overheight vehicles should stay on the frontage road). One suggestion was to replace the <i>ON FREEWAY</i> plaque with an upward slanting arrow plaque. This suggestion was used for another test sign option, in place of Sign #10 below.</p>	Yes
10		<p>While two of the District representatives preferred this sign, most of the others were concerned about the regulatory sign shape being used as a warning. Ultimately, this sign was deleted from testing and replaced with a variation of Sign 9, using an upward slanting arrow plaque in place of an <i>ON FREEWAY</i> plaque.</p>	No–replaced with modification of Sign 9 (warning sign with arrow plaque)

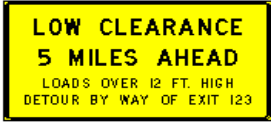
Driving Simulator Study Description

TTI houses a Realtime Technologies, Inc. desktop driving simulator that can be operated with one or three screens, depending on study requirements. During the study, test signs and “distracter” signs (road signs not pertaining to vertical clearance) were introduced to the simulation along freeway roadways to evaluate drivers’ real-time response to the signs (see [Figure 6](#)). Drivers began in the left lane of the freeway for the freeway sign scenarios, and in the right lane of the frontage road for the two frontage road sign scenarios. Prior to the start of each scenario, researchers verbally told the participants details about the height and weight of the truck they were driving. That information was also provided on a stand-up card that remained in view during the drive. However, the stated truck height was varied among participants for each sign set tested. The simulation environments were designed so that the driver had ample time to reach an instructed 55–65 mph speed before viewing the first sign in each sequence. Each test scenario included a distracter sign (such as a weight limit sign or a guide sign identifying an upcoming rest area or weigh station) followed by a vertical clearance test sign (see [Figure 7](#) and [Figure 8](#) as examples).

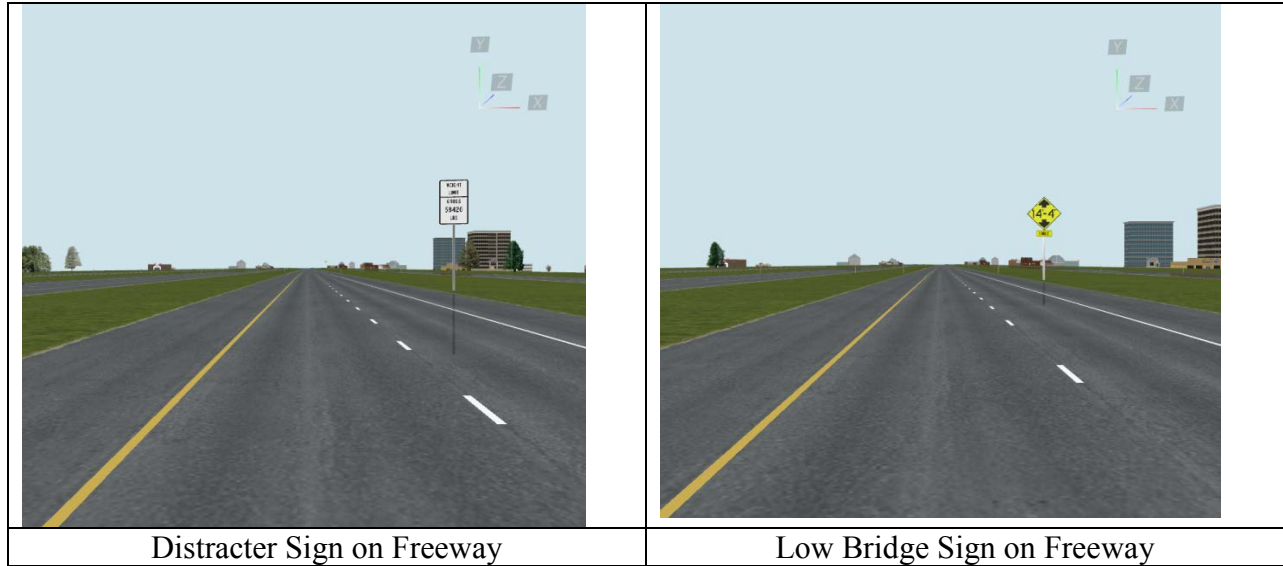

Figure 6. Screenshots of Simulation.

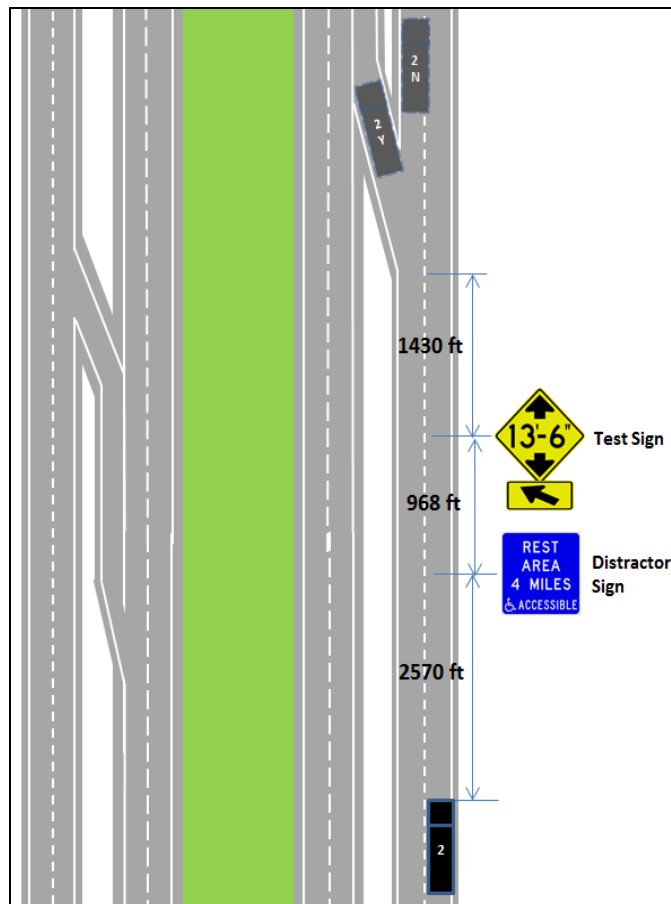

Figure 7. Example of Frontage Road Scenario.

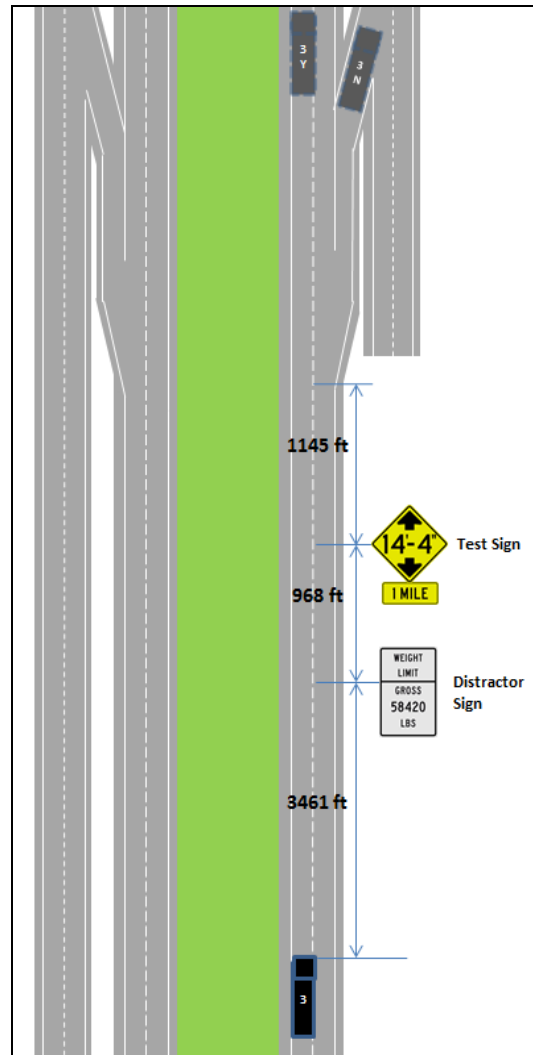

Figure 8. Example of Freeway Scenario.

The primary measure in each scenario was the driver's decision to exit or enter the freeway once he or she had viewed the test sign. Other recorded measures included lane choice with proximity to the distracter and test signs, and any unnecessary lane changes. Verbal follow-up questions were also asked following each drive segment. Questions pertaining to vertical clearance signs on the freeway in Scenarios 3 through 8 were as follows:

- What was the height limit on the sign you passed?
- What was the height of your truck?
- How confident are you on a scale of 1 to 5 in your decision to [stay on the road/exit the freeway]?

- According to the sign, how far away is the low clearance?
- If you needed to exit because of your truck's height, would you have another opportunity to exit the highway before the low clearance?

Questions pertaining to vertical clearance signs on the frontage in Scenarios 1 and 2 were as follows:

- What was the height limit on the sign you passed?
- What was the height of your truck?
- Was the height limit on the sign for the frontage road or for the freeway?
- How confident are you on a scale of 1 to 5 in your decision to [stay on the road/enter the freeway]?

Signs for Testing

Seven signs were tested, including two that are intended to be viewed on the frontage road approach (to inform drivers not to enter the freeway at a point prior to a low clearance) and five intended for freeway main lanes (to inform drivers when to exit the freeway to avoid a low clearance). The signs displayed varying height limits to prevent drivers from just recalling the height limit on the previous sign they viewed. Each of the signs was tested in a "clearance" condition and a "no clearance" condition. Half of the participants viewing each sign were given a stated truck height that was at least a foot shorter than the vertical clearance displayed on the sign (clearance) or a stated truck height that was two inches taller than the vertical clearance displayed on the sign (no clearance). This resulted in a total of 14 total test treatments (see [Table 11](#)).

Table 11. Final Test Signs and Treatments for Simulator Study.

Treatment Code	Sign	Approach	Clearance	Necessary Maneuver
1FY		Frontage	Yes	Enter Ramp
1FN		Frontage	No	Straight
2FY		Frontage	Yes	Enter Ramp
2FN		Frontage	No	Straight
3MY		Freeway	Yes	Straight
3MN		Freeway	No	Exit
4MY		Freeway	Yes	Straight
4MN		Freeway	No	Exit
5MY		Freeway	Yes	Straight
5MN		Freeway	No	Exit
6MY		Freeway	Yes	Straight
6MN		Freeway	No	Exit
7MY	 	Freeway	Yes	Straight
7MN		Freeway	No	Exit

Participant Groups

Researchers initially planned to test 48 participants, half in Houston, and half in College Station. However, there was difficulty finding College Station participants, so all but nine participants were tested in Houston. Each participant viewed seven test treatments, seeing each sign with either a “clearance” or “no clearance” condition as previously mentioned. The participants were divided into eight groups of six, who followed the various treatment orders below (see [Table 12](#)). The treatment orders were designed to minimize any learning effects among the different sign designs. The recruited participants ranged in age from 24 to 57, with an average age of 42. Their years of commercial driving experience ranged from one to 34 years, with an average experience of 14 years.

Table 12. Various Group Orders of Treatments.

Drive #	Group 1	Group 2	Group 3	Group 4	Group 5	Group 6	Group 7	Group 8
1	1FY	5MY	2FN	6MN	3MY	7MY	4MN	4MY
2	5MN	1FN	6MY	2FY	7MN	3MN	2FN	6MN
3	3MY	7MY	4MN	4MY	1FY	5MY	6MY	2FY
4	7MN	3MN	1FY	5MY	5MN	1FN	3MY	7MY
5	2FN	6MN	5MN	1FN	4MN	4MY	7MN	3MN
6	6MY	2FY	3MY	7MY	2FN	6MN	1FY	5MY
7	4MN	4MY	7MN	3MN	6MY	2FY	5MN	1FN

Results

Driver’s Decision to Enter or Exit the Freeway. The driver’s decision to enter or exit the freeway (or not) in each scenario was classified according to the lane change maneuvers they made. “Correct” maneuvers were defined as follows:

- In “no clearance” scenarios (in which the participant’s stated truck height was higher than the height shown on the test sign), correct maneuvers included a lane change (from the left to the right main lane if on the freeway, and from the right to left lane if on the frontage road) after viewing the test sign, followed by a maneuver onto the off-ramp or on-ramp.
- In “clearance” scenarios, the correct maneuver was no lane change at all if the driver had begun on the freeway (Signs 3 through 7); the driver would stay in his original lane

throughout the scenario. If the driver started on the frontage road (Signs 1 and 2), the correct maneuver in a clearance scenario was to enter the highway at the entrance ramp.

“Unnecessary” maneuvers included lane changes that did not result in a maneuver to an exit ramp in a “clearance” situation on a freeway or an entrance ramp in a “no clearance” situation on a frontage road. These were considered “correct” maneuvers as well since they didn’t alter the driver’s ultimate correct decision to exit (or not exit).

Maneuvers were counted as “incorrect” if:

- The driver in a “clearance” condition exited the freeway or failed to enter the freeway from the frontage road.
- The driver in a “no clearance” condition failed to exit the freeway or entered the freeway from the frontage road after seeing the test sign.

Test scenarios were coded with:

- The number of the sign (1 through 7).
- The letter “M” (for main lane).
- The letter “F” (for frontage road) to indicate where the sign was located within the simulation world.
- The letter “Y” to denote a “clearance” situation.
- The letter “N” to denote a “no clearance” situation. For instance, treatment “1FN” was Sign 1, on the frontage road, in a “no-clearance” situation.

[Table 13](#) shows the total percentage of correct, unnecessary, and incorrect maneuvers that participants made within each test scenario. The results in this table have been filtered to remove some incorrect maneuvers that did not appear to be related to the test sign messages. The filter removed data points where drivers made maneuver decisions based off of something other than the test sign. Generally, this was because they were responding to the distracter signs. It is important to note that the protocol was set up so that the distracter signs should never have affected the participant’s maneuver decisions; however, a few participants made decisions that they attributed to these signs rather than the test signs. Other examples of data points that this filter had eliminated are:

- A participant who did not enter the freeway because there appeared to be dark clouds on the horizon.

- A participant who exited when he read the standard green guide *EXIT* sign that marked the gore and thought it was mandatory.
- A participant who did not enter the freeway because he said he felt comfortable on the frontage road.

Table 13. Decision-Making Data (Correct, Unnecessary, and Incorrect) with First Filter.

Treatment Code	Correct Maneuvers	Unnecessary (Correct) Maneuvers	Total Correct Maneuvers	Incorrect Maneuvers	N	Total N by Sign
1FN	73.9%	4.3%	78.3%	21.7%	23	44
1FY	76.2%		76.2%	23.8%	21	
2FN	54.2%	4.2%	58.3%	41.7%	24	47
2FY	78.3%		78.3%	21.7%	23	
3MN	79.2%		79.2%	20.8%	24	48
3MY	87.5%	4.2%	91.7%	8.3%	24	
4MN	73.9%		73.9%	26.1%	23	47
4MY	87.5%		87.5%	12.5%	24	
5MN	83.3%		83.3%	16.7%	24	48
5MY	87.5%	4.2%	91.7%	8.3%	24	
6MN	63.6%		63.6%	36.4%	22	45
6MY	39.1%	26.1%	65.2%	34.8%	23	
7MN	83.3%		83.3%	16.7%	24	45
7MY	61.9%	9.5%	71.4%	28.6%	21	

Note: Data where maneuvers were made based on something other than the test sign were omitted from this table.

Some of the incorrect maneuvers shown in [Table 13](#) were the result of participants not seeing the test sign, or misremembering the stated height of their truck and/or the stated vertical clearance on the test sign. A second filter removed data points where the participant had made an incorrect maneuver and had recalled the truck’s height and/or the vertical clearance height on the sign in a way that would have required that incorrect maneuver. Multiple participants viewing Signs 6 and 7 commented that they could not read or did not see the signs, which also meant that they would not have been able to compare the vertical clearance height on the sign to the stated height of their truck. [Table 14](#) applies this second filter, omitting the incorrect maneuvers that resulted from these types of errors, in addition to the incorrect maneuvers that were filtered out in [Table 13](#). While it is important that, for instance, Signs 6 and 7 were not

seen and/or not read as consistently as the other test signs, this filter attempts to separate errors based on the sign message from errors based on visibility/legibility distance (or on participant recall of the particular height numbers).

Table 14. Subset of Decision Making Data (Correct, Unnecessary, and Incorrect) with Second Filter.

Treatment Code	Correct Maneuvers	Unnecessary (Correct) Maneuvers	Total Correct Maneuvers	Incorrect Maneuvers	N	Total N by Sign
1FN	81.0%	4.8%	85.7%	14.3%	21	41
1FY	80.0%		80.0%	20.0%	20	
2FN	54.2%	4.2%	58.3%	41.7%	24	46
2FY	81.8%		81.8%	18.2%	22	
3MN	95.0%		95.0%	5.0%	20	44
3MY	87.5%	4.2%	91.7%	8.3%	24	
4MN	73.9%		73.9%	26.1%	23	46
4MY	91.3%		91.3%	8.7%	23	
5MN	83.3%		83.3%	16.7%	24	48
5MY	87.5%	4.2%	91.7%	8.3%	24	
6MN	87.5%		87.5%	12.5%	16	32
6MY	56.3%	37.5%	93.8%	6.3%	16	
7MN	90.9%		90.9%	9.1%	22	42
7MY	65.0%	10.0%	75.0%	25.0%	20	

Note: Data where maneuvers were made based on something other than the test sign were omitted from this table, as well as data where the participant indicated they did not see the test sign or remembered the height information in a way that may have influenced their incorrect maneuver.

The total percentage of correct maneuvers for each test sign (average of the “clearance” and “no clearance” scenarios for each sign) are shown in [Table 15](#) (using first filter) and [Table 16](#) (with second filter).

Table 15. Correct Maneuvers by Sign (Clearance and No-Clearance Scenarios) with First Filter.

Treatment Code	Total Correct Maneuvers	Total N by Sign
1F	77.2%	44
2F	68.3%	47
3M	85.4%	48
4M	80.7%	47
5M	87.5%	48
6M	64.4%	45
7M	77.4%	45

Table 16. Subset of Correct Maneuvers by Sign (Clearance and No-Clearance Scenarios) with Second Filter.

Treatment Code	Total Correct Maneuvers	Total N by Sign
1F	82.9%	41
2F	70.1%	46
3M	93.3%	44
4M	82.6%	46
5M	87.5%	48
6M	90.6%	32
7M	83.0%	42

Confidence Ratings. On a scale of 1 to 5 with 5 being the most confident, participants were asked to rate how confident they were in their decision to either change roadways or stay on the current roadway. The answers were weighted and then averaged across the total number of participants for each treatment. [Table 17](#) shows the average confidence ratings among participants who made the correct maneuvers for each sign. [Table 18](#) shows the average confidence ratings among participants who made incorrect maneuvers.

Table 17. Confidence Ratings for all Correct Maneuvers (Correct plus Unnecessary).

Treatment Code	1	2	3	4	5	Weighted Average	Average by Sign
1FN	0	0	3	4	80	4.83	4.73
1FY	1	0	0	8	65	4.63	
2FN	1	0	3	0	60	4.57	4.62
2FY	0	0	9	0	75	4.67	
3MN	0	0	3	4	85	4.84	4.67
3MY	1	0	3	20	75	4.50	
4MN	0	0	6	12	70	4.63	4.65
4MY	0	0	6	12	80	4.67	
5MN	0	0	0	20	75	4.75	4.78
5MY	0	0	3	8	95	4.82	
6MN	0	0	6	16	40	4.43	4.35
6MY	2	0	3	4	55	4.27	
7MN	0	0	3	0	95	4.90	4.78
7MY	0	2	0	8	60	4.67	

Table 18. Confidence Ratings for All Incorrect Maneuvers.

Treatment Code	1	2	3	4	5	Weighted Average	Average by Sign
1FN	1	0	0	4	15	4.00	4.20
1FY	0	0	3	4	15	4.40	
2FN	0	2	6	4	30	4.20	4.00
2FY	0	0	6	8	5	3.80	
3MN	0	0	0	12	10	4.40	3.70
3MY	1	0	0	0	5	3.00	
4MN	2	0	0	4	5	2.75	3.38
4MY	0	2	0	0	10	4.00	
5MN	0	0	3	4	10	4.25	4.13
5MY	0	0	0	8	0	4.00	
6MN	1	0	6	0	25	4.00	4.13
6MY	0	2	3	4	25	4.25	
7MN	0	0	0	4	15	4.75	4.54
7MY	0	0	0	16	10	4.33	

Distance from Test Signs to Lane Changes. Figure 9 illustrates the average distance of the lane changes made in proximity to the test sign. Only the treatments that required lane maneuvers and the participants who made them correctly are considered here. (If a treatment did not require a maneuver, there was no data to consider.) For each test sign, the resulting average

lane change distance occurred after passing the sign. Appendix D contains the complete data tables pertaining to lane change distances.

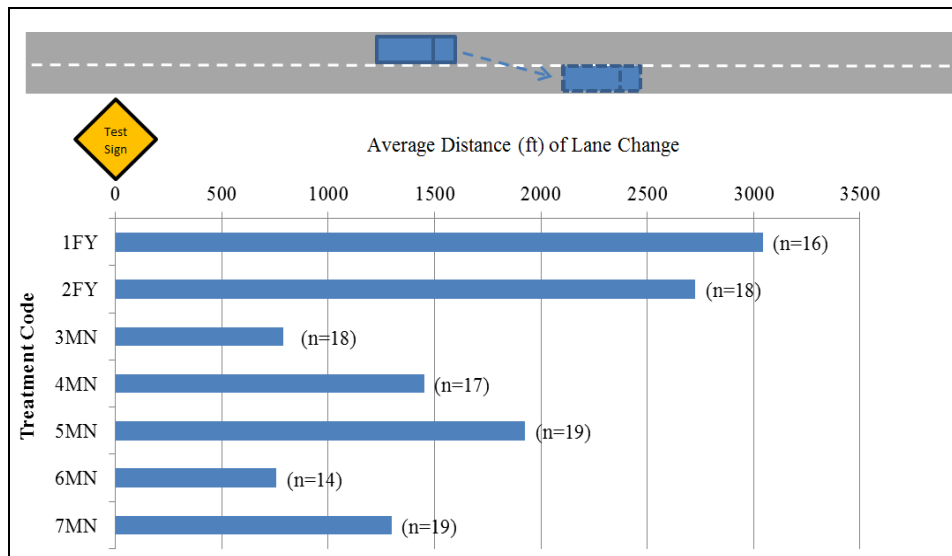

Figure 9. Average Lane Change Distance from the Test Sign.





The distances that participants traveled between the test sign and their lane change maneuver were collected to provide additional data regarding their comprehension of the sign messages, i.e., a driver might take longer to process and respond to a sign message that was less clear or that took longer to read. Some of the distance results seem to bear this out, though other factors may also have affected the outcomes.

- Signs 3 and 6 are associated with the shortest average distance (approximately 700–750 feet) from test sign to initial lane change. Sign 3 is the current MUTCD standard configuration for vertical clearance warnings, and is the configuration that the commercial drivers participating in this study are most likely to have seen before. Sign 6, while non-standard, is a visually simple sign that begins with the words *EXIT NOW*.
- Signs 4, 5, and 7, all of which were more complex visually than Signs 3 and 6 (each with two plaques in addition to the main vertical clearance warning sign), were associated with considerably longer average distances between the test sign and a lane change—approximately 1300 feet for Sign 7, 1450 feet for Sign 4, and 1900 feet for Sign 5. Among these three, Sign 7 may have had a slight advantage despite its visual complexity since the *LAST EXIT BEFORE* plaque was the first piece of information seen when reading from the top to the bottom of the sign configuration.

- The two frontage road signs have by far the longest distances between test sign and lane change. While it is possible that these signs may have taken drivers a longer time to comprehend compared to the freeway signs, the greater distance could also be due to a somewhat greater distance between the test sign and the beginning of the on-ramp in the frontage road scenarios, as compared to the distance between the test sign and the start of the exit ramp in the freeway scenarios. Participants may also have felt greater urgency to exit from the freeway if necessary in the scenarios for Signs 3–7, as compared to choosing to enter the freeway in the scenarios for Signs 1 and 2. Instructions prior to the each of the frontage road scenarios instructed drivers to “please stay in the right lane until you are sure it’s safe to enter the highway,” which different participants may have interpreted differently.





Follow-up Questions. The follow-up question “According to the sign, how far away is the low clearance?” was asked only for the test signs alongside the freeway. Sign 6 did not have a distance, so its data is not represented in Table 19. For Sign 4, the response was scored correctly if they responded “2nd Bridge,” so it is likely many incorrect responses were given because the sign does not display a distance in miles. The error “filters” that were applied to the driving maneuver data were not applied to the follow-up questions, since these questions could be answered regardless of maneuver decisions.

Table 19. Follow-Up Question “According to the Sign, How Far Away Is the Low Clearance?” (For Freeway Test Signs Only).

Sign	Correct Response	N
3. 	50.00%	48
4. 	35.42%	48
5. 	72.92%	48
7. 	31.25%	48



The second follow-up question about the test signs on the freeway was “If you needed to exit because of your truck’s height, would you have another opportunity to exit the highway before the low clearance?” The correct answer to this question was “no.” [Table 20](#) summarizes the correct answers to this question for the five freeway signs.

Table 20. Follow-Up Question “If You Needed to Exit Because of Your Truck’s Height, Would You Have Another Opportunity to Exit the Highway before the Low Clearance?” (For Freeway Test Signs Only).

Sign	Do Not Know	No	Yes	N
3. 	16.67%	43.75%	39.58%	48
4. 	12.50%	43.75%	43.75%	48
5. 	10.64%	53.19%	36.17%	47
6. 	27.66%	51.06%	21.28%	47
7. 	12.77%	59.57%	27.66%	47

The follow-up question for the two frontage road signs asked participants whether the height limit on the test sign applied to the frontage road or to the freeway. The correct answer was “the freeway.” [Table 21](#) summarizes participant responses to this question for each of the signs.

Table 21. Follow-up Question “Was the Height Limit on the Sign for the Frontage Road or for the Freeway?” (For Frontage Road Test Signs Only).

Sign	Freeway	Frontage	N
 <p>1.</p>	72.92%	27.08%	48
 <p>2.</p>	58.33%	41.67%	48

Discussion

This section presents a summary and analysis of the results for each of the seven signs tested in Phase II. Where applicable, results from Phase I are also included.

In addition to the results from all treatment conditions (average of clearance and no clearance conditions for each of the signs), this discussion also highlights results from each of the signs in the “no clearance” condition, i.e., the responses of participants when viewing signs that indicated an upcoming vertical clearance would be too low for the vehicle they were driving. While drivers’ overall comprehension of the test signs is the primary measure, the driving maneuvers participants made during “no clearance” scenarios are of particular interest because an incorrect driver response under these circumstances has a much greater chance of leading to a bridge strike. It should be noted, however, that the following results regarding this specific topic are made with fewer observations since this is only a subset of the signs considered.

Frontage Road Signs

Two frontage road signs were tested. The correct driving maneuver for participants whose stated truck height was less than the clearance shown on the sign (clearance condition) was to enter the freeway at the ramp following this sign. For stated truck heights higher than the displayed clearance height (no-clearance condition), the correct maneuver was to remain on the frontage road.

Sign 1. Sign 1 included a standard vertical clearance warning sign and a plaque displaying the words *ON FREEWAY*. When errors unrelated to the vertical clearance sign were eliminated (first filter), 77.2 percent of the participants responded with the correct driving

maneuver (remaining on the frontage road if their vehicle was too tall, entering the highway if their vehicle was short enough to pass under the low clearance). When errors related only to the stated clearance/truck height numbers were eliminated (second filter), the percentage of correct maneuvers increased to 82.9 percent. In the “no-clearance” scenario, the percentages of participants who made the correct maneuver after seeing Sign 1 were 78.3 percent (after first filter) and 85.7 percent (after second filter).

When the participants were asked about the clearance warning, 73 percent knew that the warning was for the freeway lanes.

The Phase I version of this sign used the word *RAMP* on the plaque rather than *ON FREEWAY*. Forty-three percent of Phase I survey participants selected the correct action based on that version of the sign.

Sign 2. Sign 2 included a standard vertical clearance warning sign and a plaque displaying an arrow slanted up and to the left. When errors unrelated to the vertical clearance sign were eliminated (first filter), 68.3 percent of participants responded with the correct maneuver. However, when errors related only to the stated clearance/truck height numbers were eliminated (second filter), the percentage of correct maneuvers increased to 70.1 percent. In the “no-clearance” scenario, 58.3 percent of participants made the correct maneuver after seeing Sign 1 (after filters 1 and 2).

When the participants were asked about the clearance warning, 58 percent knew that the warning was meant for the freeway lanes. There was no Phase I version of this sign.

Freeway Signs

Five freeway signs were tested. The correct driving maneuver for participants whose stated truck height was less than the clearance shown on the sign (clearance condition) was to remain on the freeway. For stated truck heights higher than the displayed clearance height (no-clearance condition), the correct maneuver was to exit the freeway at the ramp following this sign.

Sign 3. Sign 3 was a standard vertical clearance warning sign with a plaque below reading *1 MILE*. When errors unrelated to the vertical clearance sign were eliminated (first filter), 85.4 percent of participants responded with the correct maneuver (exiting the freeway in a no-clearance condition, remaining on the freeway in a clearance condition). When errors related

only to the stated clearance/truck height numbers were eliminated (second filter), the percentage of correct maneuvers rose to 93.3 percent. In the “no-clearance” scenario, the percentages of participants who made the correct maneuver after seeing Sign 1 were 79.2 percent (after first filter) and 95.0 percent (after second filter).

When the participants were asked regarding the distance to the low clearance, 50 percent correctly identified the distance to the low clearance, and only 40 percent knew that this was the last opportunity to exit prior to the low clearance.

In the Phase I survey, 68 percent of the respondents identified the correct action (exiting the highway); there was a similar lack of certainty among Phase I respondents about whether there would be another opportunity to exit.

Sign 4. Sign 4 consisted of a standard vertical clearance warning sign, with two plaques below reading 2ND *BRIDGE* and *EXIT NOW*. When errors unrelated to the vertical clearance sign were eliminated (first filter), 80.7 percent of the participants responded with the correct maneuver. When the second filter was applied, this percentage rose to 82.6 percent. In the “no-clearance” scenario, 73.9 percent of participants made the correct maneuver after seeing Sign 1 (after filters 1 and 2).

When the participants were asked, 35 percent correctly identified the distance to the low clearance (correct answer was “second bridge). Since the plaque did not specify a distance in miles, more likely this accounts for the low percentage of correct answers to this question. Just 44 percent of the participants said that this was the last opportunity to exit prior to the low clearance.

This sign resulted in the highest percentage of correct (stated) actions on the Phase I survey (92 percent). The lower comprehension/correct maneuver percentage in Phase II may be due to the shorter viewing time while in motion.

Sign 5. Sign 5 consisted of a standard vertical clearance warning sign, with two plaques below reading 3 *MILES* and *EXIT NOW*. When errors unrelated to the vertical clearance sign were eliminated (first filter), 87.5 percent of the participants responded with the correct maneuver. This percentage remained the same when the second filter was applied. In the “no-clearance” scenario, 83.3 percent of the participants made the correct maneuver after seeing Sign 1 (after filters 1 and 2)

When the participants were asked, 73 percent correctly identified the distance to the low clearance (correct answer was “second bridge”), and 53 percent said that this was the last opportunity to exit prior to the low clearance.

In Phase I, the corresponding sign (Sign F) performed similarly for percentage of correct actions; in fact, all Phase I survey respondents recognized that the sign indicated the last possible exit prior to the low clearance. The shorter viewing time may account for the difference in “last exit” results for Phase II.

Sign 6. Sign 6 was a warning sign with the message *EXIT NOW IF OVER 13'-4"*. When errors unrelated to the vertical clearance sign were eliminated (first filter), 64.4 percent of the participants responded with the correct maneuver. This was the lowest percentage of correct responses for any of the five freeway signs. However, when errors related only to the stated clearance/truck height numbers were eliminated (second filter), the percentage of correct maneuvers rose to 90.6 percent. The large number of errors related to the clearance height number on this sign is likely due to the smaller text size; all of the other tested signs featured the clearance height in a much larger font. In the “no-clearance” scenario, the percentages of participants who made the correct maneuver after seeing Sign 1 were 63.6 (after first filter) and 87.5 (after second filter)

When the participants were asked, 51 percent said that this was the last opportunity to exit prior to the low clearance.

In Phase I, the corresponding sign (Sign D) resulted in 70 percent of survey respondents selecting the correct action, and nearly all knew that there would not be another opportunity to exit.

Sign 7. Sign 7 consisted of a standard vertical clearance warning sign, with a plaque above the warning sign reading *LAST EXIT BEFORE* and a plaque below the warning sign reading *2 MILES*. When errors unrelated to the vertical clearance sign were eliminated (first filter), 77.4 percent of the participants responded with the correct maneuver. When errors related only to the stated clearance/truck height numbers were eliminated (second filter), the percentage of correct maneuvers in a no-clearance condition rose to 83 percent. In the “no-clearance” scenario, the percentages of participants who made the correct maneuver after seeing Sign 1 were 83.3 (after first filter) and 90.9 (after second filter), respectively.

When the participants were asked, 31 percent correctly identified the distance to the low clearance. This may be due to the fact that the distance information would be the last piece of information obtained when drivers read the message from top to bottom. Sixty percent of the participants knew that this instance was last opportunity to exit; this figure was the highest percentage of correct answers to this question among the five freeway sign designs. The high rate may be attributed to the *LAST EXIT BEFORE* plaque appearing first when drivers read the sign from top to bottom.

The Phase I version of this sign (E) also performed reasonably well, with 67 percent of survey respondents identifying the correct action and all respondents understanding that this sign identified the last opportunity to exit. [Table 22](#) and [Table 23](#) compare the results across the two frontage road signs and the five freeway signs.

Table 22. Summary Results for Frontage Road Signs.







Sign	Percentage of Correct Maneuvers <i>Filter 1/Filter 2</i>	Weighted Average Confidence Rating	Percentage Who Knew Warning Was for Freeway
1. 	77.2%/82.9%	4.73	73%
2. 	68.3%/70.1%	4.62	58%

Table 23. Summary Results for Freeway Signs.

Sign	Percentage of Correct Maneuvers <i>Filter 1/Filter 2</i>	Weighted Average Confidence Rating	Percentage Who Knew Distance to Low Clearance	Percentage Who Knew This Was Last Opportunity to Exit
3. 	85.4%/93.3%	4.67	50%	40%
4. 	80.2%/82.6%	4.65	35%	44%
5. 	87.5%/87.5%	4.78	73%	53%
6. 	64.4%/90.6%	4.35	n/a	51%
7. 	77.4%/83.0%	4.78	31%	60%

CONCLUSIONS AND RECOMMENDATIONS

Of the two frontage road signs tested, participants better understood Sign 1 with the *ON FREEWAY* plaque to mean that the low clearance was on the frontage road and not the freeway. This sign also resulted in participants making more correct maneuvers, although it may have taken the drivers slightly longer to comprehend and make their decision compared to the arrow plaque.

The results of the simulator testing of the five freeway signs suggest the following conclusions:

- Sign 3, representing the standard configuration recommended in the MUTCD, resulted in a high percentage of correct maneuvers in the Phase II study (up to 93.3 percent when extraneous errors were removed). However, less than half of participants were certain that the next exit would be their last opportunity to leave the highway before the low clearance. This was consistent with the results in the Phase I survey, and suggests that an additional message may be needed to specify the last possible exit to avoid the low clearance.
- Sign 5 resulted in 87.5 percent of participants making correct maneuvers and 83.3 percent when a no-clearance condition was in effect. While this percentage is still cause for concern, it represents decisions made in a simulated environment with limited viewing time to process warning signs. This sign began with the standard W12-2 vertical clearance warning sign recommended in the MUTCD, but added a plaque telling drivers when to exit, in addition to the distance plaque.
- Signs 4 and 7 resulted in fewer correct maneuvers overall compared to the other configurations that used the W12-2. The results for Sign 4, plus the fairly low percentages of correct answers to the follow-up questions, suggest that the 2ND BRIDGE plaque in place of a distance plaque may have led to some confusion. Sign 7's results showed few correct maneuvers overall, but up to 90.0 percent correct maneuvers in the no-clearance scenario; the *LAST EXIT BEFORE* plaque at the top of the sign configuration may have contributed to better comprehension of the need to exit (and may have even encouraged some participants to exit unnecessarily).
- Adding the words *LAST EXIT* or *EXIT NOW* to the vertical clearance message (Signs 5, 6, and 7) increased the percentage of participants who correctly stated that they would not have another opportunity to exit the highway prior to the low clearance.
- Sign 6 did not perform well visually; a large percentage of drivers did not have time to read the message in that format, thus resulting in a much lower N after the second filter. The message used on Sign 6 might be effective, however, if used in another format such as a dynamic message sign.

Recommendations for signing for low-clearance warnings include the following:

- The addition of an *EXIT NOW* or *LAST EXIT BEFORE* plaque seems to cue drivers to exit (if needed) better than a distance plaque alone.
- Since multiple plaques per sign may slow down or inhibit comprehension of the message, consider placing two signs ahead of the appropriate exit: the first with the vertical clearance warning sign plus a distance plaque, and the second with a vertical clearance sign plus *EXIT NOW*.
- When funding allows, consider a dynamic message sign for clearance and exit information, specifying the exit number or *EXIT NOW* for a stated upcoming vertical clearance.
- If it is not currently included, or if new sign variations are added to use in the field, add information about this type of low-clearance exit situation to commercial driver license (CDL) training curricula.

CHAPTER 2.

INCORPORATION OF MULTIPLE-CURVE PROCESSING CAPABILITY INTO THE GPS METHOD FOR SETTING ADVISORY SPEEDS

INTRODUCTION

In TxDOT Research Projects 0-5439 and 5-5439, the GPS Method for setting curve advisory speeds was developed, along with software programs to automate the required data collection and processing. Specifically, a program called Texas Roadway Analysis and Measurement Software (TRAMS) was created to record and process the data streams from a GPS receiver and an electronic ball-bank indicator while the analyst drives a test vehicle through the subject curve. This program:

- Divides the subject curve into arcs.
- Identifies the arc with the smallest radius.
- Documents the radius, superelevation rate, and deflection angle of this critical curve arc in a log file.

Additionally, a Microsoft Excel[®]-based spreadsheet program called Texas Curve Advisory Speed (TCAS) was developed to compute the curve advisory speed and recommended traffic control devices for the subject curve using the processed data that TRAMS provided.

The TRAMS program was originally developed to be used on a single curve in a given test run. The analyst was responsible for:

- Starting the software before entering the subject curve.
- Driving through the curve while tracking the centerline accurately.
- Stopping the software after exiting the curve.

In cases where multiple curves exist in close proximity, such as the case of two curves that are signed with a reverse curve sign (W1-4) and a common advisory speed, the analyst would need to conduct separate test runs through each curve.

TxDOT district practitioners subsequently expressed interest in enhancing the GPS Method software package so an analyst could drive through subsequent curves in one test run and post-process data from multiple curves at once. In this project task, macro code and controls were added to the TCAS program so the data files from a completed GPS Method test run could be post-processed to:

- Identify several curves.
- Generate report log files for each curve.
- Enter the key data attributes into the TCAS spreadsheet so advisory speeds for each curve could be computed.

This chapter describes the development of these enhancements, including a description of the methodology and the procedure for using the improved TCAS program.

METHODOLOGY

The procedure for implementing the GPS Method has been documented elsewhere (1). It requires the use of a GPS receiver and a laptop computer with the TRAMS program, and an electronic ball-bank indicator may be used if automated measurements of superelevation rate are desired. Specifically, TRAMS:

- Monitors the data streams from the data collection devices.
- Processes the data after a test run has been completed.
- Generates a Report log file containing the radius, superelevation rate, and deflection angle of the critical portion of the curve.

Optionally, TRAMS can also be configured to save:

- Log files containing the data streams from the GPS receiver and the electronic ball-bank indicator.
- An additional log file containing data records of each segment of the curve.

TRAMS Algorithm and Data Files

Bonneson et al. (2) documented the TRAMS algorithm. It is summarized in the following procedure:

1. The analyst activates the TRAMS program to start curve measurements while on the approach tangent to the curve. The program begins to record the data streams from the GPS receiver and the electronic ball-bank indicator.
2. During data recording, TRAMS applies a Kalman filter to the heading data from the GPS receiver. This process mitigates the influence of spikes and noise in the raw GPS data. The Kalman-filtered GPS headings are archived, as are the readings from the electronic ball-bank indicator.

3. The analyst completes the test run through the curve and then deactivates the TRAMS program while on the departure tangent.
4. After data recording is done, TRAMS assembles the GPS and ball-bank data into segments that sequentially describe the curve. The program computes the radius, superelevation rate, and deflection angle for each segment and archives these data.
5. Once the segment-based data are archived, TRAMS checks the deflection angles of the curve segments. If the deflection angles for the segments are less than approximately 5 degrees on average, the program aggregates data by combining segments. This aggregation criterion is based on the need to obtain radius estimates that are accurate within 5 percent of ground truth. The program then archives the data describing the aggregated segments.
6. If file saving is enabled, the archive files containing the GPS, ball-bank indicator, and segment files are saved, along with a report log file that is always generated for the test curve.

The TRAMS program is capable of generating up to four data files from each test run. These files contain both archived and processed data. The archived data represent the observations obtained from the data collection equipment, and the processed data represent detailed descriptions of the roadways that were measured, based on the archived data. [Table 24](#) describes these files.

Of the four files, only the Report log is automatically generated when the analyst saves data from a completed test run. Generation of the GPS, Rieker, and Run log files is deactivated by default when TRAMS is installed, but may be activated if desired.

The processed data elements described in [Table 24](#) either apply to an entire section of roadway that is driven during a test run, or are generated based on analysis of the entire driven section. For example, the processed data records in the Run log file represent time-based aggregations of the archived data records in the same file. The aggregation occurs if it is needed to yield segments that have deflection angles exceeding approximately 5 degrees. The TRAMS program makes this determination based on an analysis of all archived segments in the Run log file. Similarly, the Report log file is intended to describe the entire driven section, and some data attributes in this file (e.g., the total deflection angle) apply to the entire section.

Table 24. TRAMS Data File Contents

File Designation	Required File?	Data Type	File Description	Contents
Report log	Yes	Processed	One report log per test run	Curve location; total deflection angle; curve direction (right or left); latitude and longitude coordinates; test run speed; radius, superelevation rate, and deflection angle of critical segment
GPS log	No	Archived	One record per GPS reporting interval	Latitude and longitude coordinates, test vehicle speed, distance traveled, beginning and ending times, time elapsed, beginning and ending headings (Kalman-filtered), heading changes (Kalman-filtered)
Rieker log	No	Archived	One record per reading	Time and ball-bank indicator reading
	No	Processed	One record per second	Aggregated ball-bank indicator readings
Run log	No	Archived	One record per raw segment	Radius, superelevation rate, deflection angle, ball-bank indicator reading, test vehicle speed, time, latitude and longitude coordinates, total distance and time traveled, and intermediate calculation quantities for the ball-bank indicator data
	No	Processed	One record per aggregated segment	Same as the archived records for the raw segments

The previously-summarized processed data elements are sufficient to describe a curve when a test run of a single curve is conducted. However, when a test run is conducted on a roadway section that contains multiple curves, the processed data elements are not meaningful. For example, if the roadway section contained two curves of identical deflection angles that deflected in opposite directions, the Report log file would contain a total deflection angle of 0 degrees, not a separate description of each curve. In this same case, the processed data records in the Run log file would be aggregated based on an analysis of the deflection angles of all segments—those on the curves as well as those on the tangent between the curves. Hence, the level of aggregation obtained in the processed Report log file records may not be appropriate for the curves.

GPS Method Enhancement Algorithm

In this project task, new capabilities were added to the TCAS program to allow for the batch-processing of multiple curves within the archived data obtained during a TRAMS test run. The capabilities are executed using a macro titled “Batch-Process.” The “Batch-Process” macro algorithm is described in the following subsections.

Identification of Curves

To batch-process a series of curves within the TRAMS data files, it is first necessary to identify curve and tangent segments within the data. Curves are differentiated from tangents in the GPS data log file by analyzing the heading change trends across subsequent records. For each block of seven records in the file, the average and standard deviation of heading changes are computed. If the average heading change across seven records exceeds the standard deviation of the heading changes, the records are designated as curve records. Otherwise, they are designated as tangent records.

Analysis of test data files revealed that the definition of curve segments based on the analysis of averages and standard deviations of heading changes was effective for curves that were accurately tracked during the test run. Once the test vehicle is within the “circular” portion of the curve, it will experience continuous heading changes that, on average, exceed the variation in heading that the standard deviation would describe. The opposite is true on tangent segments, where the test vehicle’s heading changes little, other than small fluctuations in steering. However, steering fluctuations may occasionally result in tangent segments being identified within curves or curve segments being identified within tangents. The misidentification of tangents may occur on a gradual curve (e.g., a curve with an average radius greater than 1500 ft), but is unlikely on sharper curves.

To minimize the misidentification of tangents or curves, the total travel time for each continuous tangent or curve is computed. Additionally, the total deflection angle for each curve is computed, and for each tangent, the total deflection angle of the preceding and following curves are determined. The following rules are then applied to re-designate tangent and curve segments:

- If an identified curve corresponds to 1 second or less of test vehicle travel time, it is re-designated as a tangent. This “curve” is likely a steering fluctuation.

- If an identified tangent corresponds to 1.6 seconds or less of test vehicle travel time, and it is located between two curves that deflect in the same direction, it is redesignated as a curve, and it is combined with the preceding and following curves to form one curve. This tangent is likely a steering fluctuation within a gradual curve. Moreover, the tangent segment could be a relatively flat portion of a compound (“broken-back”) curve or a very short tangent between two successive curves. However, if the travel is less than 1.6 seconds, the roadway section would properly be analyzed, marked, and signed as a single curve, and would appear as such to a motorist.
- If a tangent segment of less than 1.6 seconds of test vehicle travel time is observed between two curves that deflect in opposite directions, it retains its designation as a tangent. This tangent is likely a true tangent between two reverse curves.

Importation of Geometric Data

After the locations of curves are identified, the geometric data contained in the archived Run log file records are imported. These records are augmented with a curve number if they correspond to one of the curves identified during the analysis of the GPS data records. The archived Rieker log file records are also imported.

Curve Processing and Record Aggregation

For each curve identified in the Run log records, a total deflection angle and length are computed. The curve’s records are also checked to determine whether aggregation is needed. If the average deflection angle for the curve records is less than approximately 5 degrees, the curve’s records are aggregated to obtain segments with larger deflection angles. The purpose of aggregation is to obtain segments for which the radius can be computed with an error no greater than 5 percent.

Report Log Generation and TCAS Data Entry

The curves in the Run log records are separately analyzed to identify their critical segment, which is the segment with the smallest radius. The radius, superelevation rate, and deflection angle for this segment are included in a Report log file. One Report log file is generated for each curve. Within the Report log files, the curves will be given the same curve number that the analyst entered into TRAMS, and also a sub-curve number that is assigned

sequentially. The data describing these curves are then pasted into the TCAS spreadsheet so the analyst can determine the advisory speed for the curves.

IMPLEMENTATION PROCEDURE

This section describes the procedure for using the “Batch-Process” macro within TCAS to analyze a series of curves driven during a GPS Method test run.

Setup

The “Batch-Process” macro uses the GPS, Rieker, and Run log files that TRAMS generated during a GPS Method test run. Hence, it is necessary to configure TRAMS to generate these files. This configuration setting is located in the File–Configuration Settings–Detailed Data Files dialog box (see [Figure 10](#)). Open the dialog box and check all three boxes.

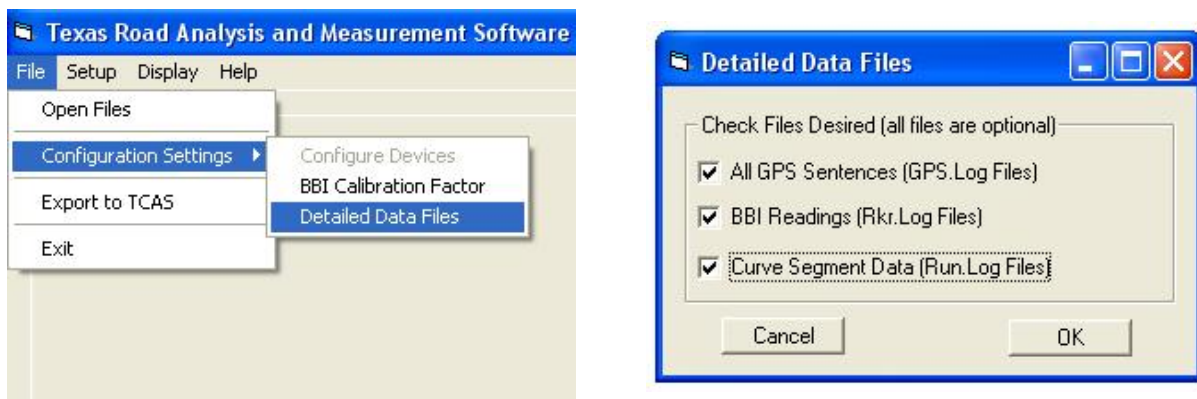

Figure 10. Detailed Data File Settings.

During the Test Run

The “Batch-Process” macro is not used until after the test run is completed. Hence, the procedures for conducting the test run are the same as described in the *Horizontal Curve Signing Handbook, Second Edition (1)*. Data collection is initiated by pressing the space bar or clicking the large button on the TRAMS main panel about 1–2 seconds of travel time prior to entering the first curve, and ended by doing the same about 1–2 seconds of travel time after exiting the last curve. The test vehicle should be driven at least 10 mph below the posted advisory speed on each curve, or 10 mph below the regulatory speed limit if advisory speeds are not provided, to a minimum of 15 mph. If an electronic ball-bank indicator is used to measure superelevation rate,

the test vehicle speed should not exceed 45 mph. For simplicity, the same speed can be used for the entire test run based on the lowest advisory speed on any of the curves.

After the Test Run

The “Batch-Process” macro is used after the test run is complete and the GPS, Rieker, and Run log files have been saved. This analysis can be conducted in the field immediately after a test run, or in the office with a large set of files from multiple test runs. Analysis procedures for the field and the office are described in the following subsections.

In-Field Analysis

After the test run is completed, open the TCAS spreadsheet program by choosing “Export to TCAS” in the File menu in TRAMS. The in-field analysis procedure involves using the TCAS(20) program, which is included as part of the TRAMS installation package. In the “Curve Data Source” drop-down menu, choose “Archived files” (see [Figure 11](#)). Then, click the “Import TRAMS data” button to import the curve data from the previous test run. Note that regulatory speed limits must be entered in row 21, or 85th-percentile tangent speeds must be entered in row 25, to obtain rounded advisory speeds for the curves. This information is not obtained from the TRAMS data.

CURVE ADVISORY SPEED WORKSHEET					
General Information					
District:		Curve Data Source:	Date:	August 28, 2013	
Highway:		Archived files	Analyst:		
Input Data					
Click button to read TRAMS data:	Import TRAMS data	Curve Identification Number			

Figure 11. TCAS Controls for In-Field Analysis.

In-Office Analysis

The in-office analysis involves using the TCAS(20)p program, which is a stand-alone program that is not directly linked to TRAMS installation. Hence, the analyst must provide additional information so the program can locate and process the data files. Open the TCAS(20)p program, select the Analysis worksheet, and scroll down to the Calibration Parameters box (see [Figure 12](#)). Input data cells are provided for the following three elements:

- Ball-bank indicator calibration factor (row 70).
- Roll rate, deg/g (row 71).
- Data file path (row 71).

CALIBRATION PARAMETERS						
Lateral shift in lane, ft	3	Side Friction Demand Increase Thresholds, g				
Ratio of average to 85th% speed	0.90		A	0.00	D	0.13
Ratio of truck speed to car speed	0.97		B	0.03	E	0.16
Ball-bank indicator calibration factor	1.00		C	0.08		
Roll rate, deg/g	6.68	Data file path	C:\TRAMS\data			

Figure 12. Calibration Parameters for TCAS In-Office Analysis.

For the ball-bank indicator calibration factor and the roll rate, enter the same values that were indicated in TRAMS during the test run. The default values are 1.00 and 6.68 deg/g, respectively. For the data file path, enter the location of the data folder that is created when TRAMS is installed, or the location where the data files have been stored if different computers are used for the TRAMS test run and the in-office analysis. The program will check the contents of the specified folder every time:

- The program is opened.
- “Archived files” is chosen in the “Curve Data Source” drop-down menu.
- A new data file path is entered into the worksheet while “Curve Data Source” is chosen in the drop-down menu. The “Curve Data Source” menu is located near the top of the worksheet (see [Figure 13](#)).

CURVE ADVISORY SPEED WORKSHEET						
General Information						
District:		Curve Data Source:	Date: August 28, 2013			
Highway:		Archived files	Analyst:			
Input Data						
Data Description	Curve Identification Number					
	1	2	3	4	5	6

Figure 13. TCAS Curve Data Source Control for In-Office Analysis.

If an erroneous data file path is entered, or if no data files are located in the data folder, the program will provide a warning message (see [Figure 14](#)).

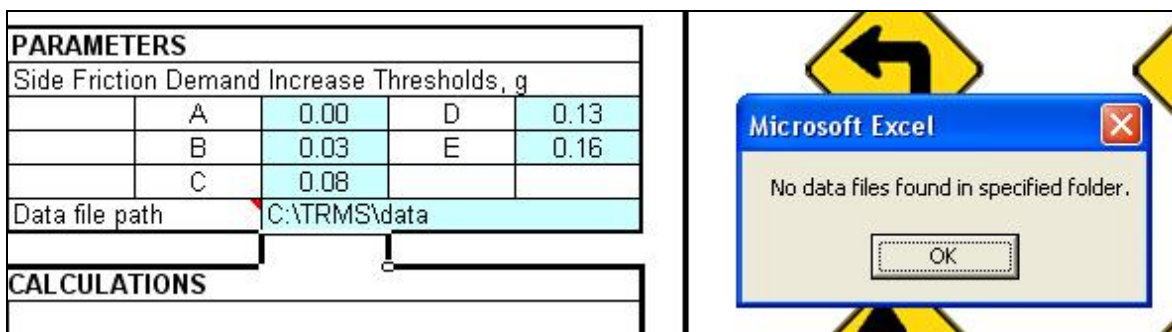

Figure 14. Warning Message for Data Files.

“Archived files” must be chosen in the “Curve Data Source” drop-down menu to conduct the in-office analysis of a GPS Method test run that included multiple curves.

When the program checks the contents of the data folder, it updates a second drop-down menu with the list of data files that are located in the folder. This menu is located to the right of the data entry portion of the worksheet, in a box labeled “Curve Data File Controls” that is located above the diagram that shows heading measurement (see [Figure 15](#)). The choices listed in this menu match the GPS log files that are located in the data folder, with the file extension omitted.

The file name shown in the menu in [Figure 15](#) is: “20130424-111916-JK_R.” This information indicates that the test run was conducted on April 24, 2013, at 11:19:16 AM, and that the curve number the analyst provided during the TRAMS test run was “JK_R.”

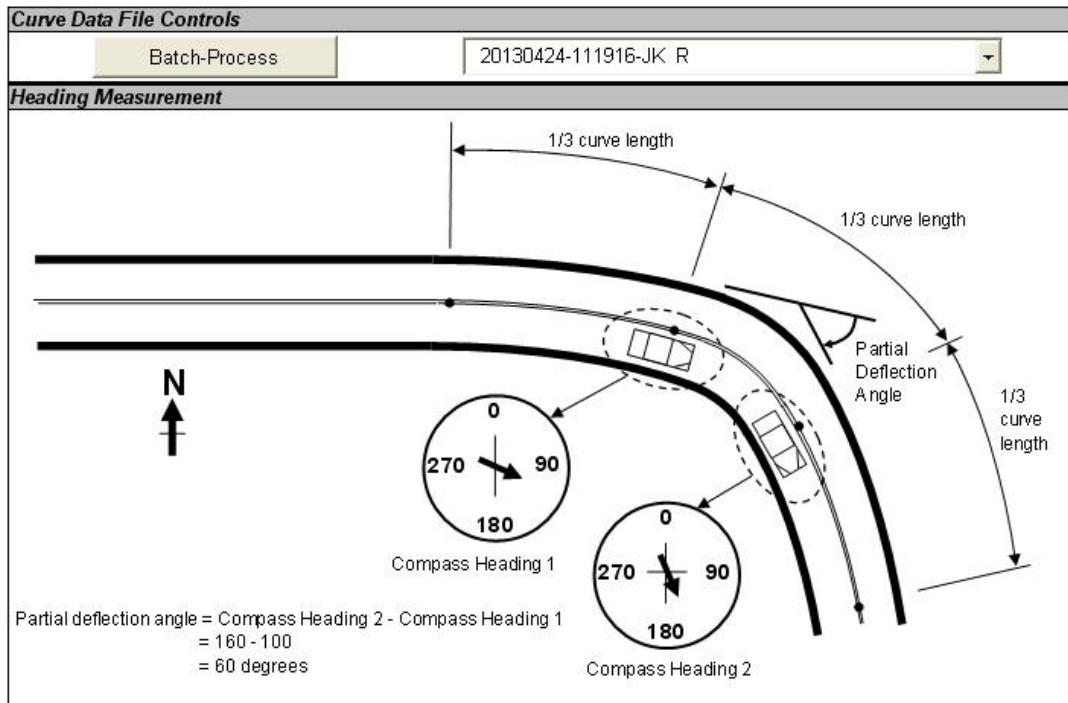

Figure 15. TCAS Data File and Batch-Process Controls for In-Office Analysis.

To conduct the in-office analysis, choose a file in the drop-down menu and click the “Batch-Process” button to import the curve data from the previous test run. Note that regulatory speed limits must be entered in row 21, or 85th-percentile tangent speeds must be entered in row 25, to obtain rounded advisory speeds for the curves. This information is not obtained from the TRAMS data.

Saving the Processed Data

When the “Batch-Process” macro is executed, it generates new Report log files for each curve in the roadway section that was driven during the test run, and saves these files in the data folder. Each Report log file will be named with the curve number that the analyst provided during the TRAMS test run, and a sub-curve number that begins with “S.” For example, if the roadway section described with a curve number of “JK_R” contains two curves, the two Report log files will be named “JK_R_S1” and “JK_R_S2.”

The “Batch-Process” macro also populates the data columns in the TCAS Analysis worksheet with the same data that are saved within the Report log files for each sub-curve. The TCAS worksheet containing these data may be retained by saving the workbook with a different name.

Each time the “Batch-Process” macro is executed, it generates new Report log files and populates data columns within the TCAS Analysis worksheet. If the worksheet cells are previously populated with data, the cells will be overwritten with the new data. Similarly, if Report log files already exist for the same test run (as the identical curve number indicated), the Report log files will be overwritten.

RESULTS

The “Batch-Process” macro was tested rigorously to ensure that it yielded accurate results and properly reproduced the data calculation and aggregation routines that were coded within the TRAMS program. Limitations of the “Batch-Process” macro were also identified. The validation procedures and the identified limitations are described in the following subsections.

Validation Procedures

Validation data sets were collected by using TRAMS to conduct several multiple-curve test runs. These data sets consisted of roadway sections with two curves that deflect in opposite directions. [Table 25](#) summarized the data sets.

Table 25. Validation Data Set Description.

Data Set Number	Total Length (mi)	Curve 1 Description	Intermediate Tangent Length (mi)	Curve 2 Description	Notes
1	0.38	Radius: 480 ft Length: 0.12 mi	0.12	Radius: 330 ft Length: 0.09 mi	This data set was collected for both curves in one run and for each curve individually.
2	0.55	Radius: 1830 ft Length: 0.14 mi	0.14	Radius: 1570 ft Length: 0.18 mi	This data set was collected in both travel directions.

Segment Aggregation Calculations

The “Batch-Process” macro was first tested to verify that it accurately reproduced the segment aggregation calculations performed within TRAMS when a single curve is driven. The data sets used for this test were the data from the two curves in validation data set 1, when the curves were driven individually. This test was conducted by comparing the processed data records in the curves’ Run log files with the aggregated data records that the “Batch-Process”

macro produced. For the first curve, the two sets of aggregated data records matched. This finding shows that the “Batch-Process” macro reproduces the aggregation calculations performed within TRAMS.

For the second curve, the “Batch-Process” macro determined that the curve segments did not need to be aggregated, though they were aggregated when analyzed within the TRAMS program. Further analysis revealed that the deflection angles for the curve segments in the archived data were about 5 degrees on average, which is sufficiently large that aggregation is not needed. The TRAMS program aggregated the archived data records because its computation of average deflection angle per archived record included approach and departure tangent records, resulting in a slight underestimate of deflection angle for the curve records. Conversely, the “Batch-Process” macro identified the approach and departure tangents as tangents, and excluded them from the calculation of average deflection angle. In other words, the macro determines the need for segment aggregation based on the actual curve records, excluding approach and departure tangents, and hence will aggregate records less often than the TRAMS program.

Accurate Identification of Curves and Tangents

Both validation data sets were used to test the “Batch-Process” macro’s ability to identify curves and tangents accurately. This test was conducted by comparing intermediate output from the macro’s operations with the Run log file, with points that were plotted on an aerial photograph using the latitude and longitude coordinates from the Run log file records. In all cases, the break points between tangents and curves in the intermediate Run log output matched the locations of the break points on the aerial photograph. In fact, steering fluctuations that occurred during the collection of the second validation data set led to incorrect identification of several short curves and tangents, which were subsequently corrected in refinements to the macro code.

The first validation data set was altered by deleting most of the data records describing the intermediate tangent, such that the two curves appeared to be separated by a tangent of about 0.01 mi (or 50 ft) in length instead of the 0.12-mi tangent that actually existed. In this case, the macro still correctly identified and processed the two curves, with results identical to those when the unaltered data set was processed.

Consistency between Repeated Applications

Finally, the results of the “Batch-Process” macro calculations were compared for consistency between repeated test runs at the same locations. This evaluation was conducted by comparing the results of:

- The individual-curve runs and the combined-curve runs with the first data set.
- The test runs in the two directions of travel with the second data set. In all cases, the analysis results for the same curves were comparable.

It was determined that differences between test runs were typical for what would be observed in repeated test runs, since a slightly different travel path is driven in each test run.

Limitations

The following limitations of the TRAMS and TCAS programs were identified during the development and testing of the “Batch-Process” macro.

Maximum Test Run Length

Because of data buffering limitations, the TRAMS program allows no more than 250 GPS data records to be saved during a test run. This means that with a 5-Hz GPS receiver, the test run length would be limited to the distance traveled in 50 seconds. This amount of time is likely adequate for most cases where two or three successive curves are located in sufficiently close proximity that they need to be signed with a reverse curve (W1-4) or winding road (W1-5) sign and a common advisory speed.

Identification of “Related” Curves

The “Batch-Process” macro allows successive curves in a single test run to be analyzed. However, it does not output the lengths of tangent segments between these curves. Developing this capability would have required a significant restructuring of the TCAS program. Hence, the analyst must separately obtain the distance between successive curves to determine whether they are in sufficiently close proximity that they need to be signed with a common warning sign and advisory speed plaque.

Total Deflection Angle Measurements

It was determined that when the researchers compared the output of both TRAMS and the “Batch-Process” macro, they found that the radius, superelevation rate, and deflection angle estimates for curve segments were almost identical. However, the total deflection angle estimates that the “Batch-Process” macro produced were found to be slight underestimates of the ground-truth total deflection angles, compared to the total deflection angle estimates of TRAMS. The magnitude of the error was about 5–10 percent of the ground-truth total deflection angle. The reason for the underestimate is that when the “Batch-Process” macro identifies curves, it tends to exclude segments near the endpoints of the curve where the test vehicle driver had not yet fully steered into the curve (i.e., the test vehicle’s path included de-facto spiral transitions that did not reflect the pavement markings of the curve). This issue is very unlikely to lead to incorrect determinations of advisory speed. Additionally, the issue can be minimized with more careful tracking of the pavement markings.

CHAPTER 3. GUIDELINES FOR SIGN SHEETING MATERIAL FOR RURAL APPLICATIONS

INTRODUCTION

The Federal Highway Administration (FHWA) has completed a series of research projects to develop recommended minimum traffic sign retroreflectivity levels (3, 4). Based on the research results, minimum maintained traffic sign retroreflectivity levels have been added to the Manual on Uniform Traffic Control Devices (MUTCD) (5). The MUTCD minimum retroreflectivity levels were derived from conditions representative of rural highways with low visual complexity. In the meantime, industry has continued to develop sign sheeting materials with higher levels of retroreflectivity, such as those meeting the ASTM D4956 Type XI criteria (6).

The new retroreflective sign material technologies are progressively more efficient in returning light to the driver's eyes and are particularly useful in disadvantaged sign locations in urban environments with high visual complexity. Based on the coefficient of fractional retroreflection, the Type XI materials are twice as efficient as previous generations of microprismatic materials (7, 8). However, all retroreflective materials can have a wide range of performance depending on the conditions under which they are viewed and there is no single measure that ubiquitously defines their performance. This is why many specifications include retroreflectivity requirements at various combinations of measurement geometries.

On rural roadways with low traffic volumes, no roadside lighting from commercial, retail, or residential areas, and no overhead signs, certain retroreflective materials may be overpowering, leading to decreased legibility distances and discomfort or even disability glare. Anecdotal evidence from several agencies across the United States suggest that signs in rural environments can be "too bright" and may be distracting to the driving task, or even worse, cause a safety concern because of glare. In addition, the newest most efficient materials are also the most expensive.

Because of the nationwide efforts to replace signs due to minimum retroreflectivity requirements in combination with industry's push to market their "brightest" materials, managers and traffic engineers need guidance on what types of sign sheeting materials or what the upper levels of retroreflectivity should be for signs along rural highways.

OBJECTIVE

The objective of this study is to determine if signs along rural highways can be so bright that they cause reduced legibility and glare to the point of being a safety concern. If evidence suggests that either can be experienced, then recommendations for rural traffic sign retroreflectivity criteria must be developed.

A key factor of this study is the thought that the brightest signs are typically white and yellow shoulder-mounted signs located on rural two-lane highways where nighttime drivers may be using their high beam headlamps. The typical background of this environment is dark with practically no visual complexity besides roadside signs.

IMPACTS OF SIGN BRIGHTNESS

The study of sign brightness (or more technically correct, luminance) has almost exclusively focused on the lower end of the scale—in other words, the minimum amount of brightness needed for nighttime drivers to see, read, and react to the sign message in a safe manner. This study investigates the other side of the spectrum in terms of sign brightness—the effects of signs being very bright.

There is a general belief that that increasing luminance increases legibility up to a point, beyond which signs overglow and irradiation begins to blur the edges of letters, ultimately degrading legibility. The loss of legibility has been difficult to document, and previous research has not found a clear point at which legibility begins to decrease.

In 1983, Sivak et al. published work that looked at the optimal luminance for traffic signs (9). They computed the geometric mean of findings from previous research and used the crest of an inverted U-shaped luminance function derived from those previous studies. Moreover, Sivak et al. identified an optimum value of 75 cd/m² using the published results ranging from 24 to 343 cd/m². The loss of legibility at the higher luminance levels was actually quite small.

In addition to the meta analysis that Sivak et al. conducted as described above, applied research has also been carried out with different combinations of retroreflective sheeting materials used on white on green guide signs. In 1994, Mace et al. performed a study with guide signs to assess legibility of various sheeting combinations, letter styles, and letter spacing (10). The highest contrast combination of materials was ASTM D4956 Type VII legends on ASTM

D4956 Type I backgrounds with a narrowed stroke width. The researchers found this the best combination during the nighttime conditions, but performance was compromised during the daytime.

In 2005, Carlson et al. published applied research findings related to mixed combinations of retroreflective sheeting on guide signs (*11*). They found that combinations of microprismatic materials (ASTM D4956 Type VIII and Type IX) on ASTM D4956 Type III backgrounds provided the best all-around performance.

The applied research reviewed above used guide signs as the type of sign in the study. Guide signs are made with mostly white legends on green backgrounds. Everything else being equal, guide signs generally have lower luminance levels than white regulatory signs or yellow caution signs. In addition, guide signs are typically installed at disadvantaged locations (overhead and right shoulder mounted with large offset distances). Therefore, guide signs are not typically thought of as being too bright. In addition, guide signs are not as common on two-lane rural highways as they are on urban divided highways. Therefore, while the results presented above offer some indication of legibility performance by sheeting type, they may not be the most representative research studies in terms of the objectives of this study.

High Beam Usage

One of the factors that can significantly impact sign luminance is the amount of illumination reaching the sign. While the illuminance varies with distance (and other factors), a key factor controlling illuminance is the headlamp of the vehicle. Almost all headlamps have either a low beam position or a high beam position. Because of the nature of this study, the research team wanted to explore the trends in high beam usage.

A recent study in Texas evaluated high beam usage on low volume roadways using photometric readings of passing vehicles and compared the results to previous studies (*12*). The results showed moderate use of high beams on low volume, rural two-lane highways, with 42 percent of the free-flow drivers using high beam (see [Figure 16](#)). There was a wide variation in high beam use between sites. However, as vehicle volume decreases, the percent of high beam usage increases. Analyses of the Texas data showed that vehicle speed and presence of horizontal curves are statistically significant factors that contribute to the probability of high beam use.

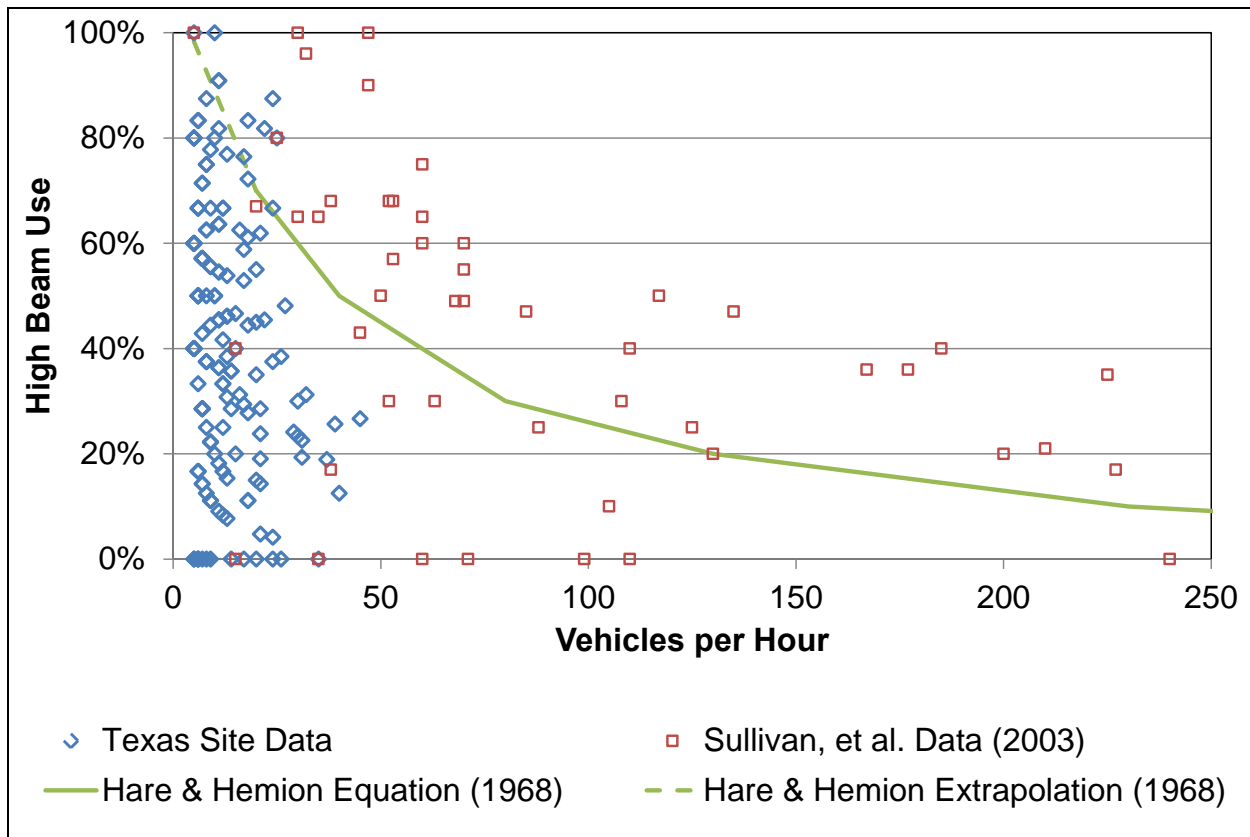

Figure 16. High Beam Usage by Vehicles per Hour.

Figure 16 shows a comparison of vehicle per hour results obtained from this Texas study with other studies on high beam usage (13, 14). The figure shows that the volumes at the sites used in this Texas study were generally lower compared to the other studies. For the 279 hours of data available at the Texas sites, the maximum “clear” volume was only 45 vehicles per hour. Sullivan et al. had data for a volume as high as 236 vehicles per hour (14). Each study shows an overall trend of decreasing high beam usage with increasing traffic volume; however, there is much variability in high beam use at the lower volumes.

Discomfort and Disability Glare

Most of the previous work regarding signs and their being too bright has focused on the impacts of legibility. However, when signs become very bright and are located in areas with low or no visual complexity, they can impact visibility by becoming glare sources. In a general sense, glare is difficulty seeing in the presence of bright light such as direct or reflected

sunlight or in the nighttime with artificial light such as car headlamps. Glare is caused by a significant ratio of luminance between the target and the glare source. Factors such as the angle between the target and the glare source, and eye adaptation have significant impacts on the experience of glare.

Glare can be generally divided into two types:

- Discomfort glare results in an instinctive desire to look away from a bright light source (such as a sign at night) or difficulty in seeing a task. It is generally described as being annoying or even causing a painful sensation.
- Disability glare actually impairs the visibility of objects and while it usually causes discomfort, it can occur without discomfort in some cases. Drivers experience disability glare when driving westward at sunset. Disability glare is often caused by the inter-reflection of light within the eyeball, reducing the contrast between task and glare source to the point where the task cannot be distinguished.

In terms of driving at night, both disability and discomfort glare can be evident.

Disability glare has been researched and described based on the physiology of the human eye and the behavior of light as it enters the ocular media. However, discomfort glare has been less defined. Discomfort glare is not based on a physical response, but rather a psychological response. A person's response to a glare source can also be based on their emotional state, in addition to the glare source itself. Several organizations and researchers have tried to establish a requirement that must be met to reduce the influence of glare from opposing headlamps and overhead roadway lighting on the drivers.

In this study, we investigated the potential of disability glare that too-bright traffic signs cause on dark rural highways. We measured the detection distances of three different-sized objects located at three different positions relative to the sign. On the sign we used two different types of retroreflective sheeting materials. To establish a baseline, we also included detection tasks without a sign present.

STUDY DESIGN

This nighttime visibility study investigated the impacts of sign presence and sign brightness on object detection distance and sign legibility distance. For the object detection task, the researchers used three targets: a small gray wooden box, a full-sized deer decoy, and a pedestrian dressed in blue medical scrubs (see [Figure 17](#)). These targets consist of relatively uniform diffuse, low-contrast surfaces. The gray wooden box and the pedestrian in blue medical scrubs have been used in a previous study.¹ The deer target is a standard decoy that can be purchased for archery practice and that is meant to represent a low-contrast animal.

A two-lane road course was marked at the Texas A&M University Riverside Campus with white edge lines and a double yellow center line. All the detection targets were located approximately one meter from the edge line, outside the travel path. The signs were located approximately two meters off the edge line. The detection targets were located at relative positions with respect to the sign: 200 ft in advance of the sign, at the sign, and 200 ft beyond the sign.

For the sign legibility task, the researchers used speed limit signs of different speeds with 10-inch tall numbers (see [Figure 17d](#)). The team recorded the distance that the participants could read the speed limit. The speed limit signs were changed throughout the course of the study from 30 to 55 mph (the participants were instructed to drive approximately 35 mph throughout the study course).

In all conditions, one of the three types of targets was used. However, in some conditions, no sign was used to establish a baseline visibility distance for the targets. When a sign was present, it was made with either retroreflective sheeting material classified as either ASTM D4956 Type III or ASTM D4956 Type XI.

¹ Carlson 9-1001 (not yet published)

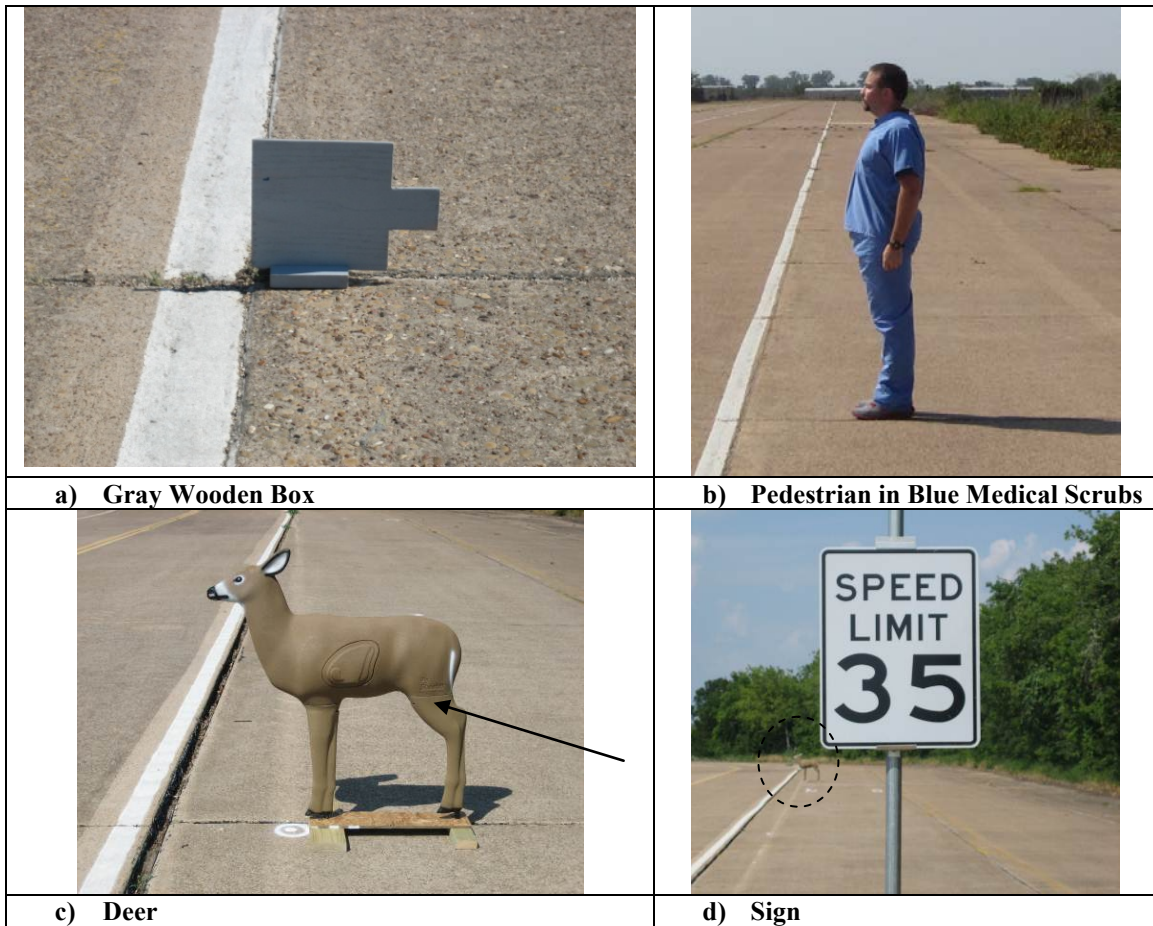

Figure 17. Detection Targets.

A total of 23 participants contributed to the study, with 11 between the age of 18 and 36 years and 12 over the age of 60 years. All participants had a valid driver's license and visual acuity of at least 20/40. During the study, the participants drove a TTI-owned Toyota Highlander equipped with a data acquisition system (DAS) that was used to record the object detection distance and legibility distance. The study was conducted at night with high-beam illumination only.

PROCEDURE

At the entrance to the Riverside Campus, TTI staff met and then escorted the participants to an office where they completed an informed consent form, a demographics questionnaire, and a Snellen visual-acuity test. The participants were given some brief instructions about what was required of them. Provided each participant did not have any reservations about conducting the required tasks, an experimenter escorted her/him to the instrumented vehicle. Once in the

vehicle, each participant was given an opportunity to familiarize herself/himself with the controls of the vehicle and adjust the vehicle seat to personal preferences. He/She was instructed to wear a seat belt at all times during the testing and to alert the researcher to any concerns throughout the study. The participant was also instructed to stop the vehicle at any point that he/she felt was necessary. Once the pre-testing process was completed, the participants drove through a closed-course route at the Texas A&M University Riverside Campus (see [Figure 18](#)) at night.



Figure 18. Texas A&M Riverside Campus.

Researchers designed the on-course study tasks to be similar to typical night driving activities, such as identifying speed limits for speed adjustments and detecting potential objects along the roadway that could affect the intended drive path. Prior to starting the study, each participant was instructed to alert the researcher the instant that he/she detected an object. For the speed limit signs, the participant was instructed to state the speed limit once it became clear. The participant was instructed to correct him/herself as soon as possible if he/she incorrectly stated an observation.

To minimize confusion and response time between the participant and the researcher, the researcher suggested terms for each object that the participant could consistently use

throughout the data collection: “wood” or “box” for the wooden plaque, “pedestrian” for the pedestrian in blue medical scrubs, and “55” for the sign. Participants used “box” most often because many of them thought the wooden plaque resembled a gray electrical box like the ones used in buildings. On the first lap, the participant used either a portion or the entire lap to become familiar with the procedure.

The in-vehicle researcher guided each participant throughout the driving course. For the majority of the data collection, the researcher remained silent and allowed the participant to follow the directions of the pavement markings. Red, retroreflective raised pavement markers (RRPM) were also placed throughout the course at key turning points and stop locations. Cones marked an 80-ft radius U-turn. At the end of each lap, the researcher asked the participant to indicate if he/she had any general or specific comments about the visibility of any of the objects or signs along the study course during the previous lap. During this down time, the research team prepared the course for the next lap in accordance to a predetermined balanced design—changing any or all of the signs, the sign position, and the detection targets. The study was completed when eight laps were made.

DATA CLEANING AND REDUCTION

Prior to analyzing the data, the research team reduced and cleaned the data. Data were first transferred from the DAS hard drives and placed on a secure TTI server. Each data set was then checked for missing data and any errors. The data were then passed to data specialists for quality checks, which included correcting any anomalies noted and verifying button presses. Ambiguous data were excluded from the overall analysis.

In all, the researchers recorded 1,178 valid detection distances throughout the project. These detection distances represent three different detection targets with and without Speed Limit signs present.

DATA ANALYSIS

Among the 1,178 recorded detection distances:

- 393 were for the deer.
- 381 were for the pedestrian.
- 404 were with the wood box.

For results involving Speed Limit signs:

- 496 records involved Speed Limit signs with TYPE XI sheeting material.
- 507 included Speed Limit signs with TYPE III sheeting material.
- 175 observations had no sign present (in order to set a baseline condition).

For those observations involving signs:

- 337 had objects located 200 ft before the sign.
- 51 observations included objects at the sign.
- 315 had objects 200 ft after the sign.

In terms of drivers' age, 518 observations were made with young drivers and 660 were made with older drivers. The detailed summary of the recorded detection distances in each category is listed in [Table 26](#).

Table 26. Summary of Detection Distance in Each Category.

Object type	Object location	Sign type	Driver age	Num	Mean	Std Dev	Lower 95% CL	Upper 95% CL
DEER	200ft after	TYPE XI	young	26	346.8	59.7	322.7	370.9
			old	27	321.9	67.9	295.0	348.7
		TYPE III	young	24	420.5	71.0	390.5	450.4
			old	33	327.9	89.7	296.0	359.7
	200ft before	TYPE XI	young	25	298.6	75.9	267.3	329.9
			old	30	239.6	89.7	206.1	273.1
		TYPE III	young	25	377.4	97.5	337.2	417.6
			old	31	351.2	140.6	299.7	402.8
	at sign	TYPE XI	young	25	265.7	86.8	229.8	301.5
			old	30	218.4	68.6	192.8	244.0
		TYPE III	young	25	322.4	89.8	285.4	359.5
			old	32	260.5	72.4	234.5	286.6
PED	200ft after	TYPE XI	young	13	355.4	81.2	306.4	404.5
			old	18	327.4	142.9	256.3	398.5
		TYPE III	young	26	363.8	90.8	327.1	400.5
			old	34	323.6	92.6	291.3	356.0
	200ft before	TYPE XI	young	25	322.8	127.0	270.3	375.2
			old	34	270.1	107.0	232.7	307.4
		TYPE III	young	24	353.2	95.7	312.8	393.6
			old	34	305.9	85.6	276.0	335.7
	at sign	TYPE XI	young	28	281.9	81.3	250.4	313.4
			old	35	191.5	65.2	169.1	213.9
		TYPE III	young	23	300.4	109.1	253.3	347.6
			old	33	245.7	99.0	210.6	280.8
WOOD	200ft after	TYPE XI	young	23	261.2	103.0	216.7	305.7
			old	36	205.2	109.1	168.3	242.1
		TYPE III	young	25	290.9	97.9	250.4	331.3
			old	30	284.8	84.9	253.0	316.5
	200ft before	TYPE XI	young	29	233.3	98.9	195.7	270.9
			old	31	185.4	85.7	154.0	216.9
		TYPE III	young	24	182.1	85.4	146.1	218.2
			old	25	234.9	104.1	191.9	277.8
	at sign	TYPE XI	young	27	249.5	69.1	222.1	276.8
			old	34	225.2	99.7	190.4	260.0
		TYPE III	young	25	274.5	88.0	238.2	310.8
			old	34	246.7	88.9	215.6	277.7

The average detection distances for the detection targets in terms of different sign types, object locations, and drivers' ages are shown in [Figure 19](#), [Figure 20](#), and [Figure 21](#), respectively. The x-axis represents different categories of data. The y-axis represents detection

distance with the I-bars representing the 95 percent confidence intervals of detection distances in each category.

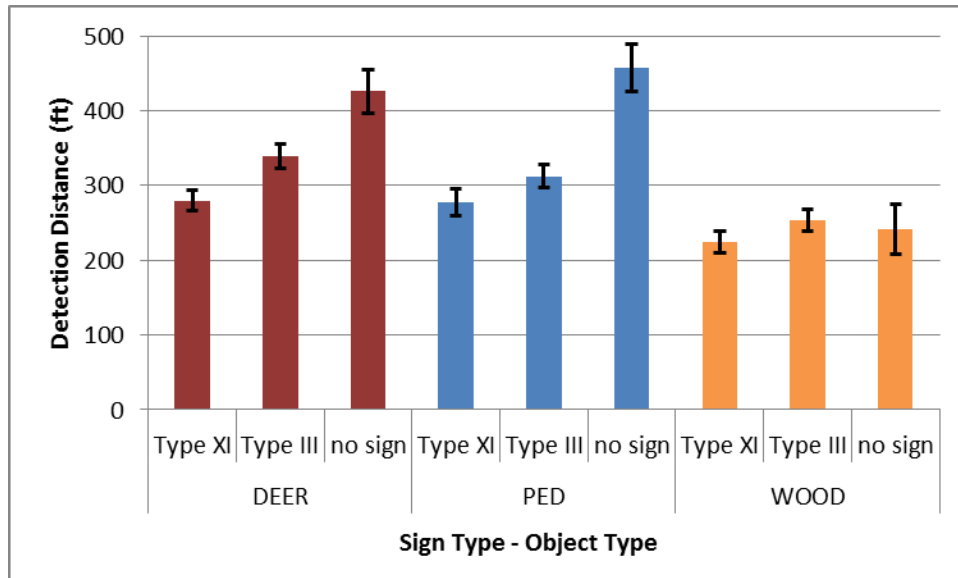

Figure 19. Detection Distance for Detection Targets.

Figure 19 shows some expected findings. For instance, the average detection distances of the deer and pedestrian were longer than those of the wood box. Figure 19 also shows an interesting trend regarding the effect of sign presence and sign sheeting material. When there was no sign, the average detection distances for deer and pedestrian were longer than when a sign was present with Type III sheeting material or with Type XI sign sheeting material. This indicates that the presence of sign (and the material used on signs) has an effect on target detection distance. For the wooden target, the presence of the sign and/or the materials used on the sign appeared to have little impact on the detection distance.

When a sign was present, the average detection distance varied with the relative location of the object with respect to the sign (see Figure 20). For deer and pedestrian, the average detection distances were longest when the target is 200 ft behind the sign. The shortest detection distance of the deer and pedestrian were when they were located at the sign. The detection distance of the wood does not appear to be affected by its location relative to the sign.

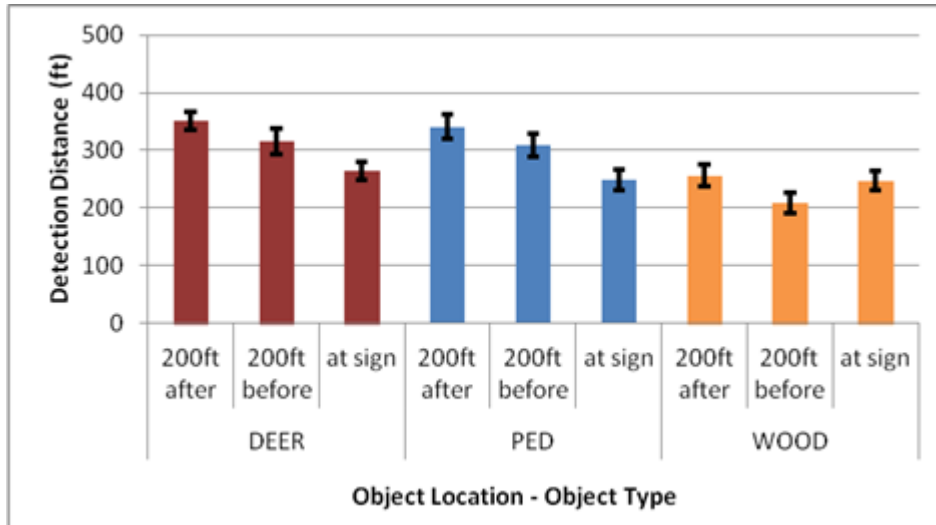

Figure 20. Detection Distance for Three Objects by Object Location.

Figure 21 shows that the younger participants had longer detection distance for all three target types. The difference is larger for the deer and pedestrians.

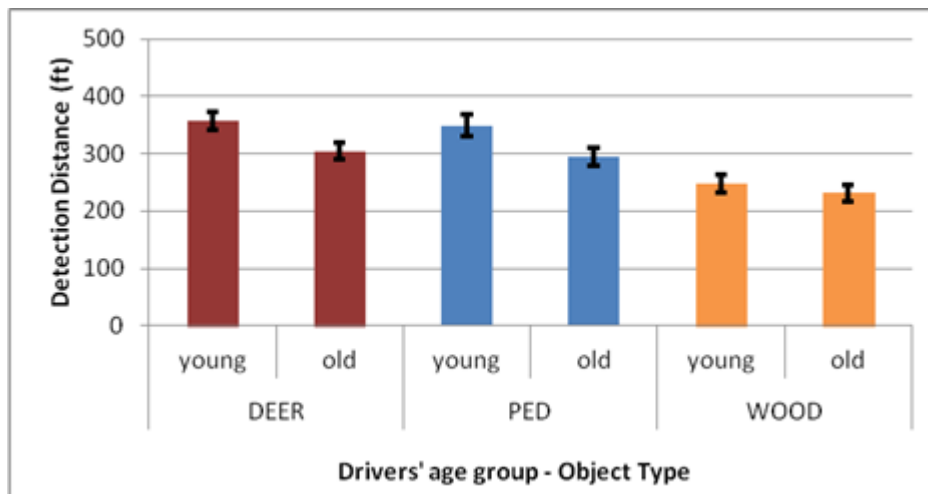

Figure 21. Detection Distance for Three Objects by Drivers' Age.

To study the data further, the researchers implemented statistical testing using analysis of variance (ANOVA) with repeated measures. Table 27 shows the ANOVA results for detection distances using object type, sign type, object location, drivers' age, and their respective interaction terms. Note that the number of observations in each category is not the same, which leads to the unbalanced ANOVA. Therefore, Type III sums of squares (SS) are used in testing

effects because these test a function of the underlying parameters that is independent of the number of observations per treatment combination.

Table 27. Analysis of Variance Results for Detection Distance.

Source	DF	Type III SS	Mean Square	F Value	Pr > F
Sheeting	1	330294.223	330294.2	38.07	<.0001
Object	2	1048419.48	524209.7	60.42	<.0001
Age	1	401096.449	401096.4	46.23	<.0001
Location	2	619900.822	309950.4	35.73	<.0001
Sheeting*Object	2	72981.547	36490.77	4.21	0.0152
Sheeting*Age	1	11866.578	11866.58	1.37	0.2425
Sheeting*Location	2	4177.458	2088.729	0.24	0.7861
Object*Age	2	62855.041	31427.52	3.62	0.0271
Object*Location	4	379627.668	94906.92	10.94	<.0001
Age*Location	2	18646	9323	1.07	0.3418
Sheeting*Object*Age	2	45078.424	22539.21	2.6	0.0749
Sheeting*Object*Location	4	102990.464	25747.62	2.97	0.0188
Sheeting*Age*Location	2	33447.354	16723.68	1.93	0.146
Object*Age*Location	4	21192.095	5298.024	0.61	0.655
Sheeting*Object*Age*Location	4	47032.526	11758.13	1.36	0.2476

The main effects of sheeting type, object type, drivers' age group, and object location are all significant (factors in bold are significant with a p-value<0.05), with three two-way interaction terms (sheeting*object, object*age, object*location) and a three-way interaction term (sheeting*object*location) significant. With respect to the objective of this study, the sheeting type and relative object location are two key factors; both are significant. The average detection distance of the three objects with no sign was 371 ft. When there was a sign with Type III sheeting, the detection distance decreased to about 302 ft. When the sign sheeting is Type XI material, the detection distance decreased even more to 258 ft.

In terms of relative object location to a sign, when the object was placed 200 ft in advance of the sign, the average detection distance of the three objects was about 279 ft. When the object was moved at the same longitudinal position as the sign, the detection distance decreased to 253 ft. When object was further moved 200 ft behind the sign, the detection distance increased to 314 ft.

ANALYSIS OF SIGN LEGIBILITY DISTANCE

In all, the researchers recorded 1,130 valid legibility distances throughout the project. These legibility distances represent two sheeting types (Type III and Type XI sign sheeting materials), three different objects (wood, pedestrian, and deer) and three relative locations to the sign (200 ft in front of sign, at sign, and 200 ft after sign) for drivers in two age groups (young for age between 18 and 34, old for age higher than 60). Among the 1,130 recorded legibility distances, 563 records included Type XI sheeting material and 567 included Type III sheeting material; 333 records included deer, 327 included the pedestrian, 343 included the wood box, and 127 had no object present. There were 493 records with young drivers and 637 with old drivers. [Table 28](#) has the detailed summary of the recorded legibility distances in each category.

Table 28. Summary of Legibility Distance in Each Category.

Sign type	Object type	Object location	Driver age	n	Mean	Std Dev	Lower 95% CL	Upper 95% CL	
TYPE XI	DEER	200ft after	Young	26	507.5	119.3	459.3	555.7	
			Old	27	449.1	93.7	412.1	486.2	
		200ft before	Young	25	475.9	129.0	422.7	529.2	
			Old	30	389.6	82.3	358.9	420.3	
		At sign	Young	25	485.1	110.9	439.3	530.9	
			Old	30	433.1	96.6	397.0	469.2	
	PED	200ft after	Young	13	507.0	108.9	441.2	572.8	
			Old	18	410.2	94.2	363.3	457.1	
		200ft before	Young	25	428.9	117.1	380.6	477.3	
			Old	34	347.9	79.5	320.2	375.7	
		At sign	Young	28	503.4	111.3	460.2	546.6	
			Old	35	416.6	114.1	377.4	455.8	
	WOOD	200ft after	Young	23	484.9	119.7	433.1	536.6	
			Old	36	401.8	104.0	366.6	437.0	
		200ft before	Young	29	496.5	142.0	442.5	550.5	
			Old	31	389.2	113.7	347.5	430.9	
		At sign	Young	27	498.5	120.7	450.7	546.3	
			Old	34	429.0	99.0	394.5	463.6	
	none	No sign	Young	26	503.6	123.8	453.6	553.6	
			Old	41	423.2	112.2	387.8	458.6	
	TYPE III	DEER	200ft after	Young	24	486.3	103.3	442.7	529.9
				Old	33	377.2	102.1	341.0	413.4
			200ft before	Young	25	492.8	99.8	451.6	534.0
				Old	31	428.4	139.5	377.2	479.5
At sign			Young	25	466.1	84.2	431.3	500.8	
			Old	32	381.0	84.0	350.7	411.3	
PED		200ft after	Young	26	462.6	115.6	415.9	509.3	
			Old	34	386.2	90.7	354.6	417.8	
		200ft before	Young	24	457.7	94.8	417.7	497.8	
			Old	34	394.7	99.7	360.0	429.5	
		At sign	Young	23	488.1	98.0	445.7	530.4	
			Old	33	387.5	92.0	354.9	420.1	
WOOD		200ft after	Young	25	499.5	111.9	453.4	545.7	
			Old	30	405.3	79.9	375.5	435.1	
		200ft before	Young	24	489.9	136.0	432.4	547.3	
			Old	25	442.1	109.1	397.0	487.1	
		At sign	Young	25	499.5	111.0	453.6	545.3	
			Old	34	388.9	90.4	357.3	420.4	
None		No sign	Young	25	465.3	113.0	418.6	511.9	
			Old	35	372.0	84.5	343.0	401.0	

In the initial statistical analyses, it was determined that the main effects of object type location were not statistically significant in terms of the legibility distances. Therefore, we ran an unbalanced ANOVA using sheeting type and drivers' age grouping as the main effect variables. Table 29 shows the result.

Table 29. Analysis of Variance Results for Legibility Distance.

Source	DF	Type III SS	Mean Square	F Value	Pr > F
Sheeting	1	52694.209	52694.21	4.66	0.031
Age	1	1710742	1710742	151.44	<.0001
Sheeting*age	1	1744.813	1744.813	0.15	0.6944

The main effects of sheeting type and drivers' age group are significant (factors in bold are significant with a p-value<0.05). The average legibility distance for signs with Type XI sheeting was 444 ft. When the sign sheeting used Type III material, the legibility distance decreased to 432 ft. The young group had an average legibility of 484 ft while the older group had an average legibility distance of 401 ft.

DISCUSSION OF RESULTS

Even though the sheeting type was deemed statistically significant in terms of legibility distance, the average difference was only 12 ft (with longer legibility distances being recorded with signs made from Type XI material versus Type III material). The impacts of the type sheeting material used to construct the sign had less influence on legibility than target detection distance. The average detection distance from a condition with no sign to signs made with Type III decreased about 70 ft and then decreased by almost another 50 ft with signs made with Type XI material.

In terms of legibility, it is quite possible that the luminance of the sign was near optimal for both types of sheeting material. Based on past experience, legibility would be expected to fall off rapidly when luminance was too low (e.g., less than 1 cd/m²); and possibly fall off rapidly when luminance becomes too high (e.g., greater than 1,000 cd/m²). However, the data from the previous studies demonstrate that there is likely to be a relatively large range of luminance where sign legibility performance is likely to be relatively flat. It is quite possible that the sign luminance levels observed in this study were mostly included in the range where

performance, in terms of legibility, is not affected. The maximum luminance of the Type III material was measured near 200 cd/m² and over 500 cd/m² for the Type XI material.

That being said, within the relatively large luminance range of relatively flat legibility performance, there can be other factors worth consideration. In this case, glare is one of those factors. Depending on the sign luminance, and the complexity and ambient luminance of surrounding area, glare can narrow the band of ideal sign luminance (compared to considering only legibility). Because glare depends on factors that are tied to urban and rural conditions (i.e., complexity and ambient luminance of surrounding area), it may be reasonable to have varying sign performance criteria based on conditions such as urban versus rural.

In this case, the researchers studied rural conditions. The impacts in terms of sign legibility alone indicate that sign sheeting material is not a key factor in terms of performance. However, considering the impacts of object detection, the effects of sign presence and sheeting material become more pronounced.

The largest difference in object detection was over 100 ft. More specifically, a white sign made with Type XI sign sheeting material decreased the average object detection distance versus no sign present by over 100 ft. For a sign made with Type III sign sheeting materials, the impact was almost 70 ft. For perspective, the braking distance of a contemporary vehicle (one having antilock brakes and maintained tires) on a typical pavement going about 45 to 50 mph is 95 to 120 ft.

The most evident finding from the object detection task is that unnecessary signs should be removed because even signs made with Type III material impact (decrease) target detection. In addition, removing unnecessary signs eliminates the objects that vehicles might hit and likewise removes the need to maintain those assets.

Regarding the development of guidelines for sign sheeting criteria in rural areas, the findings from the object detection task provide evidence that detection distance can be reduced when white shoulder-mounted signs are viewed with high beam illumination. In developing recommendations as a result of this finding, the following factors were also considered.

- The most recent data on high beam usage shows that about 10 percent of nighttime drivers use their high beams when the nighttime hourly volume is 250 vph and less. About half of nighttime drivers use their high beams when the nighttime hourly volume is 50 vph and less. Note that the average daily traffic (ADT) represents the total traffic for a

year divided by 365, or the average traffic volume per day. Because most travel occurs during daytime hours, ADT is not the same as the hourly volumes referenced above. Traffic volumes fluctuate by time of day and nighttime traffic volume on rural two-lane highways can range from 5 to less than 1 percent of the ADT. For conversion of the hourly volumes referenced above, and using 2 percent, the 50 vph would be equivalent to an ADT of 2,500 vpd and the 250 vph would be equivalent to an ADT of 12,500 vpd.

- The MUTCD minimum retroreflectivity recommendations for white regulatory signs require a minimum maintenance level of 50 cd/lx/m². New Type I material is required to have an initial retroreflectivity level of 70 cd/lx/m². Initial levels for Type III and Type IV are 250 and 360 cd/lx/m², respectively. The difference between the initial requirements and maintained requirements indicates the amount of degradation of retroreflectivity that each sign type provides (in other words, a surrogate for expected service life). While higher initial retroreflectivity provides for possibly longer life of the sign in terms of minimum retroreflectivity, it also reduces nighttime target detection as shown here.
- Type I and Type II materials are not being manufactured by as many companies as in the past. In many ways, these materials are not as readily available as they have been over the past few decades. Type III and type IV materials are commonly used as equals even though their construction is quite different. Type III materials are made with micro-sized glass beads and Type IV materials are made of micro-sized prisms. Type III and Type IV materials are priced about the same.
- Research has shown that Type III materials can be expected to last 15 years before they need to be replaced. Type IV materials have not been available long enough to estimate expected sign life; however, the available data look promising.
- Neither Type III or Type IV materials come in fluorescent colors. Type VIII, Type IX, and Type XI materials include fluorescent colors, but they also have the higher retroreflectivity levels that would cause glare and reduce object detection.

RECOMMENDATIONS

Based on the findings presented above, there is evidence that shoulder-mounted signs can be too bright in rural areas with low or no visual complexity. While there was no measured reduction in legibility, there was a large reduction in the overall ability to detect potentially

hazardous objects near the roadway. In other words, the detection distances were shorter when signs were within 200 ft of the targets. More specifically, the average detection distance of the three objects with no sign was 371 ft. When there was a sign with Type III material, the detection distance decreased to about 302 ft. When the sign sheeting is Type XI material, the detection distance decreased even more to 258 ft.

With the information presented in this report, the following recommendations have been derived for sign sheeting material to be used on low-volume rural highways (with ADT of 5000 vpd or less).

- Avoid installing unnecessary signs. When considering assessing signs in reference to the MUTCD minimum retroreflectivity levels, consider removing unnecessary signs as well. Not only do these signs provide a potential hazard for errant vehicles, they also:
 - Add to the overall maintenance responsibility.
 - Breed disrespect for traffic signs.
 - Reduce the visibility of potentially hazardous objects along the roadside.
- Specify Type III or Type IV materials for regulatory signs and warning signs. If your agency uses fluorescent signs such as fluorescent yellow and fluorescent yellow green, the only current option is to use the brighter sheeting material (Types VIII, IX, or XI). Use these signs sparingly to avoid the potential hazards of reducing nighttime drivers' ability to detect objects such as deer and pedestrians along the highway.

APPENDIX A. DISTRICT FEEDBACK FORM

District _____

The following questions concern warning road users of low clearance. The MUTCD states as Guidance “Where the clearance is less than the legal maximum vehicle height, the W12-2 sign with a supplemental distance plaque should be placed at the nearest intersecting road or wide point in the road at which a vehicle can detour or turn around.”



(W-12-2 with supplemental plaque)

1. What does/would your district do in the case that the low bridge is not the first bridge a driver would approach on a freeway, yet the only available exit is prior to a taller bridge in view with a passable height?
2. How does your district approach informing the driver they can return to the freeway when they’ve exited to avoid a low clearance?
3. The following signs could be used on a **freeway** to warn drivers of the scenario previously mentioned where not the first, but the second bridge has low clearance. Are there any of these signs you would not even consider using on your roadways, and why?

	Test Sign	Details	District Input
1		MUTCD Standard	
2		Highest Scoring Sign from a previous task survey in this project	
3		Mimics MUTCD standard sign and Sign 2 above that scored high in first survey	
4		Performed comparable to MUTCD standard in previous task survey	

	Test Sign	Details	District Input
5		Eliminating Guide Sign component from a sign in previous task survey and mimicking MUTCD standard sign	
6		Concept of signing for a segment of roadway instead of just one bridge.	
7		Concept of signing for a segment of roadway instead of just one bridge.	
8		Concept of signing for a segment of roadway instead of just one bridge.	

4. The following signs could be used on a **frontage road** to warn drivers of the scenario where they should not enter the freeway if they do not meet the posted clearance. Are there any of these signs you would not even consider using on your roadways, and why?

	Test Sign	Details	District Input
9			
10		(will enlarge symbol)	

APPENDIX B. PARTICIPANT INSTRUCTIONS

Practice (Begin reading as world is started)

The driving simulator you are seated in is an interactive simulator, which means the driving scenes you experience react to your steering and pedal inputs to provide a realistic driving experience. During your drive in the simulator, please drive in a normal fashion. You can adjust your pedals at a position that is comfortable for you. You will only be using the accelerator and brake and will not need to use the clutch on the far left.

For the practice session your task is to get comfortable with driving in the simulator.

You will drive 7 short drives similar to this one. At the beginning of each drive I will give you a lane to start in and will also tell you some details about the truck you are driving. Please repeat those details back to me so that I know you heard me correctly. Let's practice that now. Please start in the left lane. The truck you are driving is 12 feet tall and weighs 30,000 pounds. *[correct the subject if they do not repeat "12 feet tall and 30,000 pounds" back to you]*

On this drive, your goal is to travel on the highway unless you decide it is necessary to move to the frontage road. Stay on the highway unless you need to exit based on the signs you see. If you decide to exit from the highway to the frontage road, make those lane changes as soon as you're sure.

Go ahead and slowly maneuver onto the roadway and accelerate to a speed of 55 to 65 mph. Don't worry about driving at an exact speed limit, just do your best to try to stay in that range. *(as the subject approaches the first sign)* Now you will see a sign that will help you decide if you can continue on the highway or if you need to exit onto the frontage road. *[Allow them to pass the signs and then make an appropriate lane change]*

After you pass the sign, please continue driving and I will ask you some questions about the sign you saw and the lane choices you made. I will instruct you when you can pull over and stop.

[Ask practice questions about the signs.]

How are you doing? Practice switching back and forth from the accelerator to the brake to get comfortable with the pedals. We can adjust the pedals' position if you need to.

Do you feel you've had enough practice? *[if no, allow them to practice a little longer]* Please slowly coast to a stop and place the car in park.

Introduction

The experimental sessions will be just like the practice session you just did. Although sometimes you will begin on the freeway, and sometimes you will begin on the frontage road.

Please remember to drive between 55 and 65 mph. I will instruct you to start in a particular lane and will tell you details about the truck you are driving. These details may change from drive to drive, so repeat them back to me. For all of the drives, assume that you are not carrying any hazardous cargo.

When you start driving, your goal is to travel on the highway unless you decide it is necessary to travel on the frontage road. That means that if you start on the highway, stay on the highway unless you need to exit based on the signs you see, and if you start on the frontage road, plan to enter the highway as soon as you safely can, again based on the signs that you see. If you decide to move from the highway to the frontage road or vice versa, make that lane change as soon as you're sure.

During your drive, I will ask you some questions about the signs you've seen and driving decisions that you made. Do you have any questions?

APPENDIX C. PARTICIPANT DATA SHEETS

Subject # _____
Date _____
City _____

Treatment **Practice**
Group _____
Researcher _____

Practice: Experimenter loads sim world **FullSim**, data file **Low Bridge Practice**

Participant ID#: [2-digit subject #]

Drive ID#: 0

-Practice begins with maintaining speeds and moving foot from gas to brake, continues past one road sign. Participant makes decision to exit the frontage road or not.

Instructions: **“Please stay in the left lane unless you see a reason to change and drive at a speed of about 55 to 65 mph. The truck you are driving weighs 30,000 pounds and is 12 feet tall.”**

[Sketch the drive in the diagram to the right with respect to the s

[After subject has exited or passed the exit, begin follow-up ques

-DO NOT Stop Simulation until after follow-up questions.

NOTES:

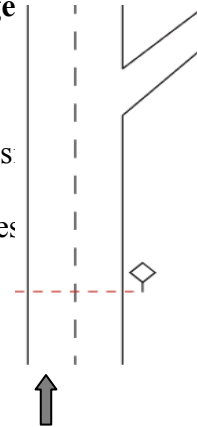

Follow-up Questions:

- What about the sign made you [stay on the roadway/exit the roadway]?
- How confident are you on a scale of 1 to 5 about your decision to [stay on the roadway/exit the roadway], where 5 is the most confident

Subject # _____
Date _____
City _____

Treatment **1FY**
Group _____
Researcher _____

Scenario 1: Load sim world **FullSim**, data file **Low Bridge S1**

Participant ID#: [2-digit subject #]

Drive ID#: 1

-Scenario begins in right lane of frontage road, continues past two road signs. Participant makes decision to enter freeway or not.

Instructions: **“You will begin in the right lane on the frontage road and your goal is to get on the highway if you can do so safely based on the signs you see. Please stay in the right lane until you are sure it’s safe to enter the highway, and drive at a speed of about 55 to 65 mph. The truck you are driving weighs 30,000 pounds and is 11 feet, 8 inches tall.”**

[Sketch the drive in the diagram to the right with respect to the sign and exit]

[After subject has exited or passed the exit, begin follow-up questions]

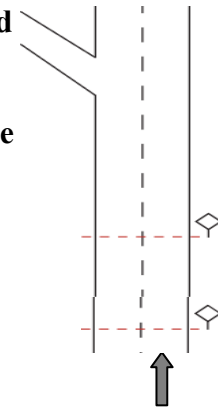

-DO NOT Stop Simulation until after follow-up questions

NOTES:

Follow-up Questions:

- What was the height limit on the sign that you passed? **12ft, 8in** Other: _____
- What was the height of your truck? **11ft, 8in** Other: _____
- Was the height limit on the sign for the frontage road or the freeway?
- How confident are you on a scale of 1 to 5 about your decision to [stay on the roadway/enter the freeway], where 5 is the most confident?
- What was the weight limit on the first sign?
- Based on that weight limit, would you be able to continue on the road?

Subject # _____
Date _____
City _____

Treatment **1FN**
Group _____
Researcher _____

Scenario 1: Load sim world **FullSim**, data file **Low Bridge S1**

Participant ID#: [2-digit subject #]

Drive ID#: 1

-Scenario begins in right lane of frontage road, continues past two road signs. Participant makes decision to enter freeway or not.

Instructions: **“You will begin in the right lane on the frontage road and your goal is to get on the highway if you can do so safely based on the signs you see. Please stay in the right lane until you are sure it’s safe to enter the highway, and drive at a speed of about 55 to 65 mph. The truck you are driving weighs 30,000 pounds and is 12 feet, 10 inches tall.”**

[Sketch the drive in the diagram to the right with respect to the sign and exit]

[After subject has exited or passed the exit, begin follow-up questions]

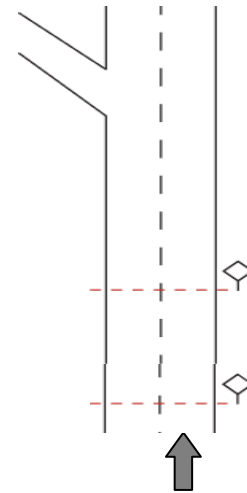

-DO NOT Stop Simulation until after follow-up questions

NOTES:

Follow-up Questions:

- What was the height limit on the sign that you passed? **12ft, 8in** Other: _____
- What was the height of your truck? **12ft, 10in** Other: _____
- Was the height limit on the sign for the frontage road or the freeway?
- How confident are you on a scale of 1 to 5 about your decision to [stay on the roadway/ enter the freeway], where 5 is the most confident?
- What was the weight limit on the first sign?

Based on that weight limit, would you be able to continue on the road?

Subject # _____
Date _____
City _____

Treatment **2FY**
Group _____
Researcher _____

Scenario 2: Experimenter keeps sim world **FullSim**, data file **Low Bridge S2**

Participant ID#: [2-digit subject #]

Drive ID#: 2

-Scenario begins in right lane of frontage road, continues past two road signs. Participant makes decision to enter freeway or not.

Instructions: **“You will begin in the right lane on the frontage road and your goal is to get on the highway if you can do so safely based on the signs you see. Please stay in the right lane until you are sure it’s safe to enter the highway, and drive at a speed of about 55 to 65 mph. The truck you are driving weighs 30,000 pounds and is 12 feet, 6 inches tall.”**

[Sketch the drive in the diagram to the right with respect to the sign and exit]

[After subject has exited or passed the exit, begin follow-up questions]

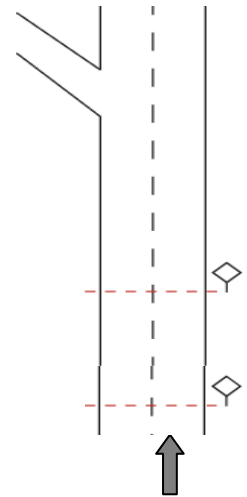

-DO NOT Stop Simulation until after follow-up questions

NOTES:

Follow-up Questions:

- What was the height limit on the sign that you passed? **13ft, 6in**
Other: _____
- What was the height of your truck? **12ft, 6in** **Other:** _____
- Was the height limit on the sign for the frontage road or the freeway?
- How confident are you on a scale of 1 to 5 about your decision to [stay on the roadway/ enter the freeway], where 5 is the most confident?
- Based on the first sign you passed, how far ahead will you need to stop?

Subject # _____
Date _____
City _____

Treatment **2FN**
Group _____
Researcher _____

Scenario 2: Experimenter keeps sim world **FullSim**, data file **Low Bridge S2**

Participant ID#: [2-digit subject #]

Drive ID#: 2

-Scenario begins in right lane of frontage road, continues past two road signs. Participant makes decision to enter freeway or not.

Instructions: **“You will begin in the right lane on the frontage road and your goal is to get on the highway if you can do so safely based on the signs you see. Please stay in the right lane until you are sure it’s safe to enter the highway, and drive at a speed of about 55 to 65 mph. The truck you are driving weighs 30,000 pounds and is 13 feet, 8 inches tall.”**

[Sketch the drive in the diagram to the right with respect to the sign and exit]

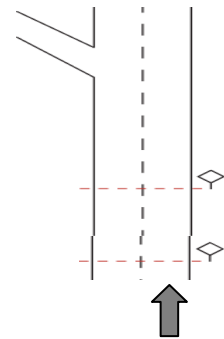

[After subject has exited or passed the exit, begin follow-up questions]

-DO NOT Stop Simulation until after follow-up questions

NOTES:

Follow-up Questions:

- What was the height limit on the sign that you passed? **13ft, 6in** Other: _____
- What was the height of your truck? **13ft, 8in** Other: _____
- Was the height limit on the sign for the frontage road or the freeway?
- How confident are you on a scale of 1 to 5 about your decision to [stay on the roadway/enter the freeway], where 5 is the most confident?
- Based on the first sign you passed, how far ahead will you need to stop?

Subject # _____
Date _____
City _____

Treatment **3MY**
Group _____
Researcher _____

Scenario 3: Experimenter keeps sim world **FullSim**, data file **Low Bridge S3**

Participant ID#: [2-digit subject #]

Drive ID#: 3

-Scenario begins in left lane of freeway, continues past two road signs. Participant makes decision to exit freeway or not.

Instructions: **“Please stay in the left lane unless you see a reason to change, and drive at a speed of about 55 to 65 mph. The truck you are driving weighs 30,000 pounds and is 13 feet, 4 inches tall.”**

[Sketch the drive in the diagram to the right with respect to the sign and exit]

[After subject has exited or passed the exit, begin follow-up questions]

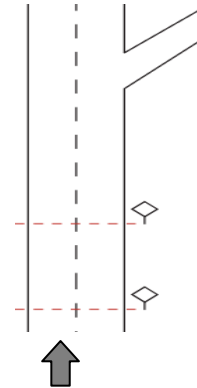

-DO NOT Stop Simulation until after follow-up questions

NOTES:

Follow-up Questions:

- What was the height limit on the sign that you passed? **14ft, 4in** Other: _____
- What was the height of your truck? **13ft, 4in** Other: _____
- According to the sign, how far away is the low clearance?
- [If you needed to exit because of your truck’s height,] would you have another opportunity to exit the highway before the low clearance?
- How confident are you on a scale of 1 to 5 in your decision to [stay on the road/exit the roadway]?
- What was the weight limit on the first sign you saw?
- [Would/will] you be able to continue on the road based on the weight limit?

Subject # _____
Date _____
City _____

Treatment **3MN**
Group _____
Researcher _____

Scenario 3: Experimenter keeps sim world **FullSim**, data file **Low Bridge S3**

Participant ID#: [2-digit subject #]

Drive ID#: 3

**-Scenario begins in left lane of freeway, continues past two road signs.
Participant makes decision to exit freeway or not.**

Instructions: **“Please stay in the left lane unless you see a reason to change, and drive at a speed of about 55 to 65 mph. The truck you are driving weighs 30,000 pounds and is 14 feet, 6 inches tall.”**

[Sketch the drive in the diagram to the right with respect to the sign and exit]

[After subject has exited or passed the exit, begin follow-up questions]

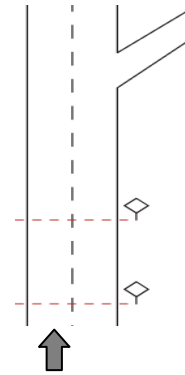

-DO NOT Stop Simulation until after follow-up questions

NOTES:

Follow-up Questions:

- What was the height limit on the sign that you passed? **14ft, 4in** Other: _____
- What was the height of your truck? **14ft, 6in** Other: _____
- According to the sign, how far away is the low clearance?
- [If you needed to exit because of your truck's height,] would you have another opportunity to exit the highway before the low clearance?
- How confident are you on a scale of 1 to 5 in your decision to [stay on the road/exit the roadway]?
- What was the weight limit on the first sign you saw?
- [Would/will] you be able to continue on the road based on the weight limit?

Subject # _____
Date _____
City _____

Treatment **4MY**
Group _____
Researcher _____

Scenario 4: Experimenter keeps sim world **FullSim**, data file **Low Bridge S4**

Participant ID#: [2-digit subject #]

Drive ID#: 4

**-Scenario begins in left lane of freeway, continues past two road signs.
Participant makes decision to exit freeway or not.**

Instructions: **“Please stay in the left lane unless you see a reason to change, and drive at a speed of about 55 to 65 mph. The truck you are driving weighs 30,000 pounds and is 13 feet, 8 inches tall.”**

[Sketch the drive in the diagram to the right with respect to the sign and exit]

[After subject has exited or passed the exit, begin follow-up questions]

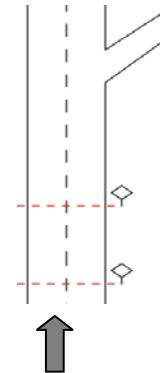

-DO NOT Stop Simulation until after follow-up questions

NOTES:

- Follow-up Questions:
- What was the height limit on the sign that you passed? **14ft, 8in**
Other: _____
- What was the height of your truck? **13ft, 8in** **Other:** _____
- According to the sign, how far away is the low clearance?
- [If you needed to exit because of your truck’s height,] would you have another opportunity to exit the highway before the low clearance?
- How confident are you on a scale of 1 to 5 in your decision to [stay on the road/exit the roadway]?
- What did the first sign tell you about the road?

Subject # _____
Date _____
City _____

Treatment **4MN**
Group _____
Researcher _____

Scenario 4: Experimenter keeps sim world **FullSim**, data file **Low Bridge S4**

Participant ID#: [2-digit subject #]

Drive ID#: 4

-Scenario begins in left lane of freeway, continues past two road signs. Participant makes decision to exit freeway or not.

Instructions: **“Please stay in the left lane unless you see a reason to change, and drive at a speed of about 55 to 65 mph. The truck you are driving weighs 30,000 pounds and is 14 feet, 10 inches tall.”**

[Sketch the drive in the diagram to the right with respect to the sign and exit]

[After subject has exited or passed the exit, begin follow-up questions]

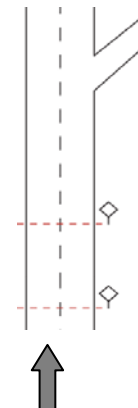

-DO NOT Stop Simulation until after follow-up questions

NOTES:

Follow-up Questions:

- What was the height limit on the sign that you passed? **14ft, 8in** Other: _____
- What was the height of your truck? **14ft, 10in** Other: _____
- According to the sign, how far away is the low clearance?
- [If you needed to exit because of your truck’s height,] would you have another opportunity to exit the highway before the low clearance?
- How confident are you on a scale of 1 to 5 in your decision to [stay on the road/exit the roadway]?
- What did the first sign tell you about the road?

Subject # _____
Date _____
City _____

Treatment **5MY**
Group _____
Researcher _____

Scenario 5: Experimenter keeps sim world **FullSim**, data file **Low Bridge S5**
Participant ID#: [2-digit subject #]
Drive ID#: 5

-Scenario begins in left lane of freeway, continues past two road signs. Participant makes decision to exit freeway or not.

Instructions: **“Please stay in the left lane unless you see a reason to change, and drive at a speed of about 55 to 65 mph. The truck you are driving weighs 30,000 pounds and is 11 feet, 6 inches tall.”**

[Sketch the drive in the diagram to the right with respect to the sign and exit]

[After subject has exited or passed the exit, begin follow-up questions]

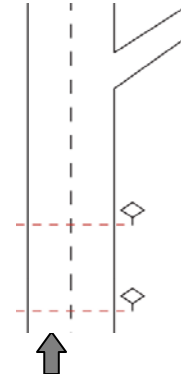

-DO NOT Stop Simulation until after follow-up questions

NOTES:

Follow-up Questions:

- What was the height limit on the sign that you passed? **12ft, 6in** Other: _____
- What was the height of your truck? **11ft, 6in** Other: _____
- According to the sign, how far away is the low clearance?
- [If you needed to exit because of your truck’s height,] would you have another opportunity to exit the highway before the low clearance?
- How confident are you on a scale of 1 to 5 in your decision to [stay on the road/exit the roadway]?
- How far ahead is the weigh station, according to the first sign you passed?

Subject # _____
Date _____
City _____

Treatment **5MN**
Group _____
Researcher _____

Scenario 5: Experimenter keeps sim world **FullSim**, data file **Low Bridge S5**

Participant ID#: [2-digit subject #]

Drive ID#: 5

-Scenario begins in left lane of freeway, continues past two road signs. Participant makes decision to exit freeway or not.

Instructions: **“Please stay in the left lane unless you see a reason to change, and drive at a speed of about 55 to 65 mph. The truck you are driving weighs 30,000 pounds and is 12 feet, 8 inches tall.”**

[Sketch the drive in the diagram to the right with respect to the sign and exit]

[After subject has exited or passed the exit, begin follow-up questions]

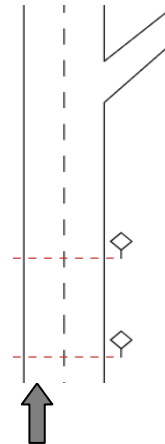

-DO NOT Stop Simulation until after follow-up questions

NOTES:

Follow-up Questions:

- What was the height limit on the sign that you passed? **12ft, 6in** Other: _____
- What was the height of your truck? **12ft, 8in** Other: _____
- According to the sign, how far away is the low clearance?
- [If you needed to exit because of your truck's height,] would you have another opportunity to exit the highway before the low clearance?
- How confident are you on a scale of 1 to 5 in your decision to [stay on the road/exit the roadway]?
- How far ahead is the weigh station?

Subject # _____
Date _____
City _____

Treatment **6MY**
Group _____
Researcher _____

Scenario 6: Experimenter keeps sim world **FullSim**, data file **Low Bridge S6**

Participant ID#: [2-digit subject #]

Drive ID#: **6**

-Scenario begins in left lane of freeway, continues past two road signs. Participant makes decision to exit freeway or not.

Instructions: **“Please stay in the left lane unless you see a reason to change, and drive at a speed of about 55 to 65 mph. The truck you are driving weighs 30,000 pounds and is 12 feet, 4 inches tall.”**

[Sketch the drive in the diagram to the right with respect to the sign and exit]

[After subject has exited or passed the exit, begin follow-up questions]

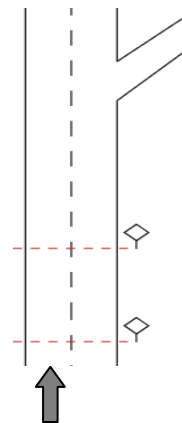

-DO NOT Stop Simulation until after follow-up questions

NOTES:

Follow-up Questions:

- What was the height limit on the sign that you passed? **13ft, 4in** Other: _____
- What was the height of your truck? **12ft, 4in** Other: _____
- According to the sign, how far away is the low clearance?
- [If you needed to exit because of your truck’s height,] would you have another opportunity to exit the highway before the low clearance?
- How confident are you on a scale of 1 to 5 in your decision to [stay on the road/exit the roadway]?
- How far ahead is the inspection station?

Subject # _____
Date _____
City _____

Treatment **6MN**
Group _____
Researcher _____

Scenario 6: Experimenter keeps sim world **FullSim**, data file **Low Bridge S6**

Participant ID#: [2-digit subject #]

Drive ID#: **6**

-Scenario begins in left lane of freeway, continues past two road signs. Participant makes decision to exit freeway or not.

Instructions: **“Please stay in the left lane unless you see a reason to change, and drive at a speed of about 55 to 65 mph. The truck you are driving weighs 30,000 pounds and is 13 feet, 6 inches tall.”**

[Sketch the drive in the diagram to the right with respect to the sign and exit]

[After subject has exited or passed the exit, begin follow-up questions]

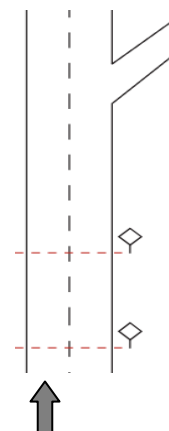

-DO NOT Stop Simulation until after follow-up questions

NOTES:

Follow-up Questions:

- What was the height limit on the sign that you passed? **13ft, 4in** Other: _____
- What was the height of your truck? **13ft, 6in** Other: _____
- According to the sign, how far away is the low clearance?
- [If you needed to exit because of your truck’s height,] would you have another opportunity to exit the highway before the low clearance?
- How confident are you on a scale of 1 to 5 in your decision to [stay on the road/exit the roadway]?
- How far ahead is the inspection station?

Subject # _____
Date _____
City _____

Treatment **7MY**
Group _____
Researcher _____

Scenario 7: Experimenter keeps sim world **FullSim**, data file **Low Bridge S7**

Participant ID#: [2-digit subject #]

Drive ID#: 7

-Scenario begins in left lane of freeway, continues past two road signs. Participant makes decision to exit freeway or not.

Instructions: **“Please stay in the left lane unless you see a reason to change, and drive at a speed of about 55 to 65 mph. The truck you are driving weighs 30,000 pounds and is 13 feet, 6 inches tall.”**

[Sketch the drive in the diagram to the right with respect to the sign and exit]

[After subject has exited or passed the exit, begin follow-up questions]

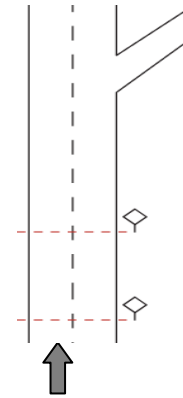

-DO NOT Stop Simulation until after follow-up questions

NOTES:

Follow-up Questions:

- What was the height limit on the sign that you passed? **14ft, 6in** Other: _____
- What was the height of your truck? **13ft, 6in** Other: _____
- According to the sign, how far away is the low clearance?
- [If you needed to exit because of your truck’s height,] would you have another opportunity to exit the highway before the low clearance?
- How confident are you on a scale of 1 to 5 in your decision to [stay on the road/exit the roadway]?
- What was the weight limit on the first sign you saw?
- [Would/will] you be able to continue on the road based on the weight limit?

Subject # _____
Date _____
City _____

Treatment **7MN**
Group _____
Researcher _____

Scenario 7: Experimenter keeps sim world **FullSim**, data file **Low Bridge S7**

Participant ID#: [2-digit subject #]

Drive ID#: 7

-Scenario begins in left lane of freeway, continues past two road signs. Participant makes decision to exit freeway or not.

Instructions: **“Please stay in the left lane unless you see a reason to change, and drive at a speed of about 55 to 65 mph. The truck you are driving weighs 30,000 pounds and is 14 feet, 8 inches tall.”**

[Sketch the drive in the diagram to the right with respect to the sign and exit]

[After subject has exited or passed the exit, begin follow-up questions]

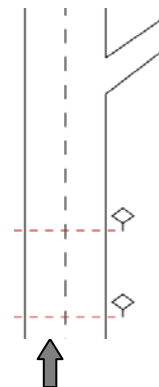

-DO NOT Stop Simulation until after follow-up questions

NOTES:

Follow-up Questions:

- What was the height limit on the sign that you passed? **14ft, 6in** Other: _____
- What was the height of your truck? **14ft, 8in** Other: _____
- According to the sign, how far away is the low clearance?
- [If you needed to exit because of your truck's height,] would you have another opportunity to exit the highway before the low clearance?
- How confident are you on a scale of 1 to 5 in your decision to [stay on the road/exit the roadway]?
- What was the weight limit on the first sign you saw?
- [Would/will] you be able to continue on the road based on the weight limit?

APPENDIX D. DISTANCE TO LANE CHANGE

Treatment Code	Subject ID	Distance (ft)*	Average Distance (ft)
IFY	1	225.5	3044.1
	3	1013.1	
	4	1538	
	13	535.7	
	14	1125.4	
	15	569.6	
	17	825.2	
	18	1288.2	
	25	325.5	
	26	1062.8	
	27	1027.6	
	37	1156.8	
	38	1172.7	
	39	1415.1	
2FY	41	1386.3	2725.8
	42	178.2	
	8	179.4	
	9	1531.1	
	10	390.3	
	12	1019.9	
	19	1134.9	
	20	238	
	21	996.9	
	23	915.5	
	24	1036.3	
	31	539	
	33	1513.8	
	34	82.6	
35	999.6		
43	420.7		
45	1324.8		
46	1339.5		
48	950.4		
50	341.9		
3MN	8	358.4	791
	9	535.6	
	12	511.5	
	19	724.6	
	20	167.7	

Treatment Code	Subject ID	Distance (ft)*	Average Distance (ft)
	22	889.4	
	23	140.1	
	24	-43.9	
	31	-197.7	
	33	649.6	
	34	-68	
	35	-20.8	
	43	45.2	
	45	101.1	
	46	602	
	47	236.5	
	48	-163	
	50	-128.5	
4MN	1	477.1	1451
	3	124.4	
	4	-7.3	
	5	628.4	
	14	242.7	
	15	332.4	
	17	1089.9	
	25	355.7	
	26	203.8	
	27	667.6	
	28	-14.8	
	30	955.6	
	37	630.6	
	38	557.8	
	39	950.4	
40	-90.8		
42	415.2		
5MN	1	2.1	1925.3
	4	350	
	6	682.9	
	14	981	
	15	707.9	
	16	1521.2	
	18	576.4	
	25	320.5	
26	286.4		

Treatment Code	Subject ID	Distance (ft)*	Average Distance (ft)
	27	542.2	
	28	541.1	
	29	1061.6	
	37	535.2	
	38	242.5	
	39	897.3	
	40	304.2	
	41	279.1	
	42	257.5	
	49	1060.7	
6MN	7	261.7	757.1
	8	-459.8	
	9	346.8	
	10	867.5	
	11	211	
	12	-416.8	
	19	627.3	
	31	527.7	
	32	126.5	
	34	366.7	
	35	229	
	43	-200.4	
	46	76.3	
48	667.3		
7MN	1	-71.9	1299.2
	3	-17	
	4	226.9	
	5	321.1	
	6	475.8	
	14	1010.8	
	18	814.7	
	25	499.4	
	26	131.4	
	27	353	
	28	70.4	
	30	363.7	
	37	802.7	
	38	490.8	
39	517.5		

Treatment Code	Subject ID	Distance (ft)*	Average Distance (ft)
	40	265.6	
	41	140.5	
	42	568.1	
	49	560.5	

NOTE: * distance was measured from test signs; negative values mean lane changings were done before passing test signs.

REFERENCES

- 1 Bonneson, J., M. Pratt, J. Miles, and P. Carlson. *Procedures for Setting Advisory Speed: Course Notes—Appendix A. Horizontal Curve Signing Handbook, 2nd Edition*. Report FHWA/TX-09/5-5439-01-P1, Texas Transportation Institute, College Station, Texas, 2009.
- 2 Pratt, M., J. Miles, and J. Bonneson. *Workshops on Using the GPS Method to Determine Curve Advisory Speeds*. Report FHWA/TX-09/5-5439-01-1, Texas Transportation Institute, College Station, Texas, 2009.
- 3 Carlson, P.J., and H.G. Hawkins. Minimum Retroreflectivity Levels for Overhead Guide Signs and Street-Name Signs. FHWA-RD-03-082, United States Department of Transportation, Federal Highway Administration: Washington, D.C. December 2003.
- 4 Carlson, P.J., and H.G. Hawkins. Updated Minimum Retroreflectivity Levels for Traffic Signs. FHWA-RD-03-081, United States Department of Transportation, Federal Highway Administration: Washington, D.C. July 2003.
- 5 *Manual on Uniform Traffic Control Devices (MUTCD)*, U.S. Department of Transportation, Federal Highway Administration, Washington, D.C., 2009.
- 6 ASTM D4956-11a. Standard Specification for Retroreflective Sheeting for Traffic Control. ASTM International: West Conshohoken, PA, 2011.
- 7 CIE 54.2, Retroreflection: Definition and Measurement; Technical Report for CIE Central Bureau: Vienna, Austria. 2001. <http://www.cie.co.at>.
- 8 ASTM E808-01. Standard Practice for Describing Retroreflection; ASTM International: West Conshohoken, PA, 2009.
- 9 Sivak, M. and P. Olson. Optimal and Replacement Luminance of Traffic Signs: A Review of Applied Legibility Research. Report No. UMTRI-83-43, The University of Michigan Transportation Research Institute, Ann Arbor, MI, 1983.
- 10 Mace, D, R. King, and G. Dauber. Sign Luminance Requirements for Various Background Complexities. Final Report. FHWA-RD-85-056, Federal Highway Administration, Washington, D.C., 1985.
- 11 Carlson Holick. Maximizing Legibility of Unlit Freeway Guide Signs with Clearview Font and Combinations of Retroreflective Sheeting Materials, Transportation Research Record: Journal of the Transportation Research Board, No. 1918, Transportation Research Board of the National Academies, Washington, D.C., 2005, pp. 26–34.

- 12 Irigavarapu, V. and K. Fitzpatrick. High-Beam Use on Low Volume Rural Highways In Texas, Transportation Research Board 91st Annual Meeting, Washington D.C., January 2012.
- 13 Hare C.T., R. H. Hemion. Headlamp Beam Usage on U.S. Highways. Final Report on Phase III. San Antonio: Southwest Research Institute. AR-66. 1968.
- 14 Sullivan, J. M., G. Adachi, M. L. Mefford, and M. J. Flannagan (2003) "High Beam Headlamp Usage on Unlighted Rural Roadways." Report No.UMTRI-2003-2.