



NCHRP Report 350 Crash Testing and Evaluation of the S-Square® Mailbox System



Research/Test Report 0-5210-7

Cooperative Research Program

**TEXAS TRANSPORTATION INSTITUTE
THE TEXAS A&M UNIVERSITY SYSTEM
COLLEGE STATION, TEXAS**

in cooperation with the
Texas Department of Transportation and the
Federal Highway Administration
<http://tti.tamu.edu/documents/0-5210-7.pdf>

1. Report No. FHWA/TX-10/0-5210-7		2. Government Accession No.		3. Recipient's Catalog No.	
4. Title and Subtitle NCHRP REPORT 350 CRASH TESTING AND EVALUATION OF THE S-SQUARE® MAILBOX SYSTEM				5. Report Date November 2009 Published: January 2010	
				6. Performing Organization Code	
7. Author(s) Roger P. Bligh and Wanda L. Menges				8. Performing Organization Report No. Test Report 0-5210-7	
9. Performing Organization Name and Address Texas Transportation Institute Proving Ground The Texas A&M University System College Station, Texas 77843-3135				10. Work Unit No. (TRAIS)	
				11. Contract or Grant No. Project 0-5210	
12. Sponsoring Agency Name and Address Texas Department of Transportation Research and Technology Implementation Office P.O. Box 5080 Austin, Texas 78763-5080				13. Type of Report and Period Covered Technical/Test Report: July – August 2009	
				14. Sponsoring Agency Code	
15. Supplementary Notes Project performed in cooperation with the Texas Department of Transportation and the Federal Highway Administration. Project Title: Roadside Crash Testing Program for Design Guidance and Standard Detail Development URL: http://tti.tamu.edu/documents/0-5210-7.pdf					
16. Abstract The Texas Department of Transportation desired to evaluate an alternate mailbox support system for use in Texas. S-Square® Tube Products manufactures a system that is adaptable for use with single, dual, and multiple mailboxes and is considered to provide the desired ease of installation and maintenance. Two full-scale crash tests were conducted to evaluate the safety performance of the S-Square® Tube Products dual and multiple-mailbox mounts in accordance with <i>NCHRP Report 350</i> . The S-Square® Tube Products mailbox system successfully passed all requirements of <i>NCHRP Report 350</i> and is considered ready for field implementation in single, dual, and multiple mailbox configurations.					
17. Key Words Mailbox, Breakaway Support Structure, Crash Testing, Roadside Safety			18. Distribution Statement No restrictions. This document is available to the public through NTIS: National Technical Information Service Springfield, Virginia 22161 http://www.ntis.gov		
19. Security Classif.(of this report) Unclassified		20. Security Classif.(of this page) Unclassified		21. No. of Pages 80	22. Price

**NCHRP REPORT 350 CRASH TESTING AND EVALUATION
OF THE S-SQUARE® MAILBOX SYSTEM**

by

Roger P. Bligh, P.E.
Research Engineer
Texas Transportation Institute

and

Wanda L. Menges
Research Specialist
Texas Transportation Institute

Report 0-5210-7
Project 0-5210
Project Title: Roadside Crash Testing Program for Design Guidance
and Standard Detail Development

Performed in cooperation with the
Texas Department of Transportation
and the
Federal Highway Administration

November 2009
Published: January 2010

TEXAS TRANSPORTATION INSTITUTE
The Texas A&M University System
College Station, Texas 77843-3135

DISCLAIMER

This research was performed in cooperation with the Texas Department of Transportation (TxDOT) and the Federal Highway Administration (FHWA). The contents of this report reflect the views of the authors, who are responsible for the facts and the accuracy of the data presented herein. The contents do not necessarily reflect the official view or policies of the FHWA or TxDOT. This report does not constitute a standard, specification, or regulation, and its contents are not intended for construction, bidding, or permit purposes. In addition, the above listed agencies assume no liability for its contents or use thereof. The engineer in charge of the project was Roger P. Bligh, P.E. (Texas, #78550).

The United States Government and the State of Texas do not endorse products or manufacturers. Trade or manufacturers' names appear herein solely because they are considered essential to the object of this report.

TTI PROVING GROUND DISCLAIMER

The results of the crash testing reported herein apply only to the article being tested.

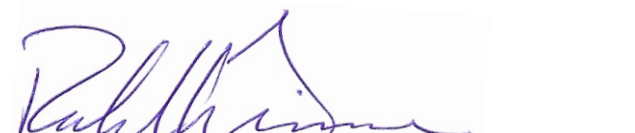

Wanda L. Menges, Research Specialist
Deputy Quality Manager

Richard A. Zimmer, Senior Research Specialist
Test Facility Manager
Quality Manager
Technical Manager

ACKNOWLEDGMENTS

This research project was conducted under a cooperative program between the Texas Transportation Institute, the Texas Department of Transportation, and the Federal Highway Administration. The TxDOT project director for this research was Rory Meza, P.E. (DES). Justin Obinna (MNT) and Toribio Garza (MNT) served as project advisors and helped guide this research. The authors acknowledge and appreciate their assistance.

TABLE OF CONTENTS

	Page
LIST OF FIGURES	ix
LIST OF TABLES	xi
CHAPTER 1. INTRODUCTION	1
BACKGROUND	1
OBJECTIVES/SCOPE OF RESEARCH	1
CHAPTER 2. CRASH TEST PROCEDURES	3
TEST FACILITY	3
TEST ARTICLE	3
CRASH TEST CONDITIONS	9
EVALUATION CRITERIA	9
CHAPTER 3. CRASH TEST RESULTS	11
TEST NO. 452109-9 (<i>NCHRP REPORT 350</i> TEST DESIGNATION 3-61) ON THE S-SQUARE® DUAL MAILBOX SYSTEM	11
Test Vehicle	11
Soil and Weather Conditions	11
Test Description	11
Damage to Test Installation	14
Vehicle Damage	14
Occupant Risk Factors	14
Assessment of Test Results	14
TEST NO. 452109-10 (<i>NCHRP REPORT 350</i> TEST DESIGNATION 3-61) ON THE S-SQUARE® MULTIPLE MAILBOX SYSTEM	23
Test Vehicle	23
Soil and Weather Conditions	23
Test Description	23
Damage to Test Installation	26
Vehicle Damage	26
Occupant Risk Factors	26
Assessment of Test Results	26
CHAPTER 4. SUMMARY AND CONCLUSIONS	35
SUMMARY OF TEST RESULTS	35
Dual Mailbox Mount	35
Multiple-Mailbox Mount	35
CONCLUSIONS	35
CHAPTER 5. IMPLEMENTATION STATEMENT	39

TABLE OF CONTENTS

	Page
REFERENCES	41
APPENDIX A. CRASH TEST AND DATA ANALYSIS PROCEDURES	43
ELECTRONIC INSTRUMENTATION AND DATA PROCESSING	43
ANTHROPOMORPHIC DUMMY INSTRUMENTATION.....	44
PHOTOGRAPHIC INSTRUMENTATION AND DATA PROCESSING	44
TEST VEHICLE PROPULSION AND GUIDANCE.....	44
APPENDIX B. TEST VEHICLE PROPERTIES AND INFORMATION	45
APPENDIX C. SEQUENTIAL PHOTOGRAPHS	51
APPENDIX D. VEHICLE ANGULAR DISPLACEMENTS AND ACCELERATIONS.....	55

LIST OF FIGURES

Figure	Page
Figure 1. Details of the S-Square® Dual Mailbox System.....	5
Figure 2. S-Square® Dual Mailbox System before Test No. 452109-9.....	6
Figure 3. Details of the S-Square® Multiple Mailbox System.....	7
Figure 4. S-Square® Multiple Mailbox System before Test No. 452109-10.....	8
Figure 5. Vehicle/Installation Geometrics for Test No. 452109-9.....	12
Figure 6. Vehicle before Test No. 452109-9.....	13
Figure 7. After Impact Trajectory Path for Test No. 452109-9.....	15
Figure 8. Installation after Test No. 452109-9.....	16
Figure 9. Vehicle after Test No. 452109-9.....	17
Figure 10. Interior of Vehicle for Test No. 452109-9.....	18
Figure 11. Summary of Results for <i>NCHRP Report 350</i> Test 3-61 on the S-Square® Dual Mailbox System.....	19
Figure 12. Vehicle/Installation Geometrics for Test No. 452109-10.....	24
Figure 13. Vehicle before Test No. 452109-10.....	25
Figure 14. After Impact Trajectory Path for Test No. 452109-10.....	27
Figure 15. Installation after Test No. 452109-10.....	28
Figure 16. Vehicle after Test No. 452109-10.....	29
Figure 17. Interior of Vehicle for Test No. 452109-10.....	30
Figure 18. Summary of Results for <i>NCHRP Report 350</i> Test 3-61 on the S-Square® Multiple Mailbox System.....	31
Figure 19. Vehicle Properties for Test No. 452109-9 and 10.....	45
Figure 20. Sequential Photographs for Test No. 452109-9 (Perpendicular and Frontal Oblique Views).....	51
Figure 21. Sequential Photographs for Test No. 452109-10 (Perpendicular and Frontal Oblique Views).....	53
Figure 22. Vehicle Angular Displacements for Test No. 452109-9.....	55
Figure 23. Vehicle Longitudinal Accelerometer Trace for Test No. 452109-9 (Accelerometer Located at Center of Gravity).....	56
Figure 24. Vehicle Lateral Accelerometer Trace for Test No. 452109-9 (Accelerometer Located at Center of Gravity).....	57
Figure 25. Vehicle Vertical Accelerometer Trace for Test No. 452109-9 (Accelerometer Located at Center of Gravity).....	58
Figure 26. Vehicle Longitudinal Accelerometer Trace for Test No. 452109-9 (Accelerometer Located over Rear Axle).....	59
Figure 27. Vehicle Lateral Accelerometer Trace for Test No. 452109-9 (Accelerometer Located over Rear Axle).....	60
Figure 28. Vehicle Vertical Accelerometer Trace for Test No. 452109-9 (Accelerometer Located over Rear Axle).....	61
Figure 29. Vehicle Angular Displacements for Test 452109-10.....	62

LIST OF FIGURES (CONTINUED)

Figure	Page
Figure 30. Vehicle Longitudinal Accelerometer Trace for Test 452109-10 (Accelerometer Located at Center of Gravity).....	63
Figure 31. Vehicle Lateral Accelerometer Trace for Test 452109-10 (Accelerometer Located at Center of Gravity).....	64
Figure 32. Vehicle Vertical Accelerometer Trace for Test 452109-10 (Accelerometer Located at Center of Gravity).....	65
Figure 33. Vehicle Longitudinal Accelerometer Trace for Test 452109-10 (Accelerometer Located over Rear Axle).....	66
Figure 34. Vehicle Lateral Accelerometer Trace for Test 452109-10 (Accelerometer Located over Rear Axle).....	67
Figure 35. Vehicle Vertical Accelerometer Trace for Test 452109-10 (Accelerometer Located over Rear Axle).....	68

LIST OF TABLES

Table	Page
Table 1. Performance Evaluation Summary for <i>NCHRP Report 350</i> Test 3-61 on the S-Square® Dual Mailbox System.....	36
Table 2. Performance Evaluation Summary for <i>NCHRP Report 350</i> Test 3-61 on the S-Square® Multiple Mailbox System.....	37
Table 3. Exterior Crush Measurements for Test No. 452109-9.....	46
Table 4. Occupant Compartment Measurements for Test No. 452109-9.....	47
Table 5. Exterior Crush Measurements for Test No. 452109-10.....	48
Table 6. Occupant Compartment Measurements for Test No. 452109-10.....	49

CHAPTER 1. INTRODUCTION

BACKGROUND

Through their research program, the Texas Department of Transportation (TxDOT) continues to be proactive in their ongoing commitment to providing safer roadsides for the traveling public. TxDOT-sponsored research has resulted in the development of many breakaway sign support and mailbox designs with demonstrated impact performance. TxDOT uses the results of in-service performance evaluations and feedback from field crews to continually assess the performance of these systems and identify areas in which design improvements can be realized in terms of cost, maintenance, or impact behavior.

As with other objects on the roadside, mailboxes can constitute a hazard to the motoring public when struck by an errant vehicle. For this reason, only crashworthy mailbox designs are permitted to be used on the state highway system. Even though crashworthy multiple-mailbox designs are available and in use, the Maintenance Division of TxDOT continues to identify and evaluate new designs that may offer advantages to existing systems in terms of cost, installation, and maintenance.

A mailbox system developed by S-Square® Tube Products is considered a candidate to provide the ease of installation and maintenance desired by TxDOT. However, before it could be used on Texas roadways, the impact performance of the design needed to be evaluated through full-scale vehicle crash testing following the guidelines of the National Cooperative Highway Research Program (NCHRP) *Report 350 (1)*.

OBJECTIVES/SCOPE OF RESEARCH

The objective of this research project was to investigate the impact performance of S-Square® Tube Products dual and multiple mailbox supports. Researchers performed the crash tests in accordance with *NCHRP Report 350* test designation 3-61. This test involves an 1808-lb passenger vehicle (820C) impacting the support structure at a nominal speed of 62.1 mi/h and an angle ranging from 0-20 degrees. The test is intended to evaluate vehicle and test article trajectory and occupant risk.

The research approach and testing methodologies followed for this project are presented in [Chapter 2](#). The results of full-scale crash testing are presented in [Chapter 3](#). A summary of findings and conclusions are presented in [Chapter 4](#). Implementation recommendations are presented in [Chapter 5](#).

CHAPTER 2. CRASH TEST PROCEDURES

TEST FACILITY

The full-scale crash tests reported herein were performed at the Texas Transportation Institute (TTI) Proving Ground. The TTI Proving Ground is an International Standards Organization (ISO) 17025 accredited laboratory with American Association for Laboratory Accreditation (A2LA) Mechanical Testing certificate 2821.01. The full-scale crash tests were performed according to the TTI Proving Ground's quality procedures and according to *NCHRP Report 350* guidelines.

The test facilities at the Texas Transportation Institute Proving Ground consist of a 2000 acre complex of research and training facilities situated 10 miles northwest of the main campus of Texas A&M University. The site, formerly an Air Force Base, has large expanses of concrete runways and parking aprons well suited for experimental research and testing in the areas of vehicle performance and handling, vehicle-roadway interaction, durability and efficacy of highway pavements, and safety evaluation of roadside safety hardware. The site selected for the installation of the mailbox systems was the edge of a wide out-of-service concrete apron. The apron consists of an unreinforced jointed concrete pavement in 12.5 ft × 15 ft blocks nominally 8-12 inches deep. The apron is over 50 years old, and the joints have some displacement but are otherwise flat and level.

TEST ARTICLE

The dual mailbox support system consisted of a 2-inch, 14-gauge NEX® post secured inside a 2.25-inch square × 30-inch long × 12-gauge thick galvanized steel anchor sleeve using a specially fabricated wedge. The NEX® post is roughly octagonal in shape but has some curvature along four of the sides. It weighs approximately 1.89 lb/ft and is fabricated from A787-94 steel having a minimum specified yield strength of 60,000 psi. The post was inserted 6 inches into the anchor sleeve and secured using a wedge that was driven into place using a hammer. The wedge was placed parallel to the roadway on the field side of the anchor sleeve.

A double mailbox bracket was attached to the top of the support post using a factory installed 0.31-inch diameter × 2.5-inch long carriage bolt and U-shaped lock wedge fabricated from 12-gauge galvanized steel. The double mailbox bracket was fabricated from 14-gauge galvanized steel in the form of an inverted channel that was 4.5 inches wide × 11-inches long and had 0.625-inch deep legs. Two overlapping L-shaped mailbox brackets were attached to the top of the double mailbox bracket at each of the mailbox mounting locations using two 0.31 inch diameter × 0.75-inch-long carriage bolts. The L-shaped brackets were fabricated from 14-gauge galvanized steel and measured 5 inches wide × 8.5-inches long and had 1-inch tall legs. The two overlapping brackets formed a channel shape that set inside the mailbox flanges.

Two large (#2) mailboxes were attached to the L-shaped mailbox brackets using sheet metal screws at a mounting height of 42 inches from the ground to the bottom of the mailboxes.

The mailboxes measured approximately 15 inches × 11.5 inches × 23.5 inches and weighed 6 lb each. The total weight of the dual mailbox support system and the two attached mailboxes was 24 lb.

[Figure 1](#) shows details of the dual mailbox support system. [Figure 2](#) shows photographs of the completed dual mailbox support test installation.

The support frame for the multiple mailbox system was fabricated from two sections of 2-inch, 14-gauge NEX® tubing. On the top end, one section of tubing slid into the other section of tubing and was secured using a 0.31-inch diameter × 2.5 inch long hex head bolt. On the lower end, the two legs of the bent tubing ran parallel to one another and were secured to each other near the ground line using two 0.31-inch diameter × 4.5-inch long hex head bolts. When assembled, the tubing formed a triangular, “hairpin” shape. One leg of the support extended 6 inches beyond the other leg for insertion into the 2.25-inch square × 30-inch long × 12-gauge thick galvanized steel anchor sleeve. The support tube was inserted 6 inches into the anchor sleeve and secured using a wedge that was seated firmly with a hammer. The wedge was placed parallel to the roadway on the field side of the anchor sleeve.

The top of the support tube had a level top section measuring approximately 42.5 inches long to which four mailboxes were attached. Two of these mailboxes were small (#1), and two of the mailboxes were large (#2). The small mailboxes measured approximately 9 inches × 7 inches × 19 inches and weighed 3.4 lb. The large mailboxes measured approximately 15 inches × 11.5 inches × 23.5 inches and weighed 6 lb.

At each mailbox location, two overlapping, adjustable L-shaped mailbox brackets were attached to the top of the support tube using a back plate bracket and two 0.31 inch diameter × 0.75-inch long carriage bolts. The back plate bracket was fabricated out of 14-gauge galvanized steel and had the same shape as the 2-inch NEX® tubing. The L-shaped brackets were fabricated from 14-gauge galvanized steel and measured 5 inches wide × 8.5-inches long and had 1 inch tall legs. The two overlapping brackets formed a channel shape that set inside the mailbox flanges. The mailboxes were attached to the L-shaped mailbox brackets using sheet metal screws at a mounting height of 42 inches from the ground to the bottom of the mailboxes. The total weight of the multiple mailbox support system and the four attached mailboxes was 49 lb.

The anchor sleeves for both the dual and multiple mailbox systems were installed in *NCHRP Report 350* standard soil. Details of the multiple mailbox support system are presented in [Figure 3](#). [Figure 4](#) shows photographs of the completed multiple mailbox support test installation.

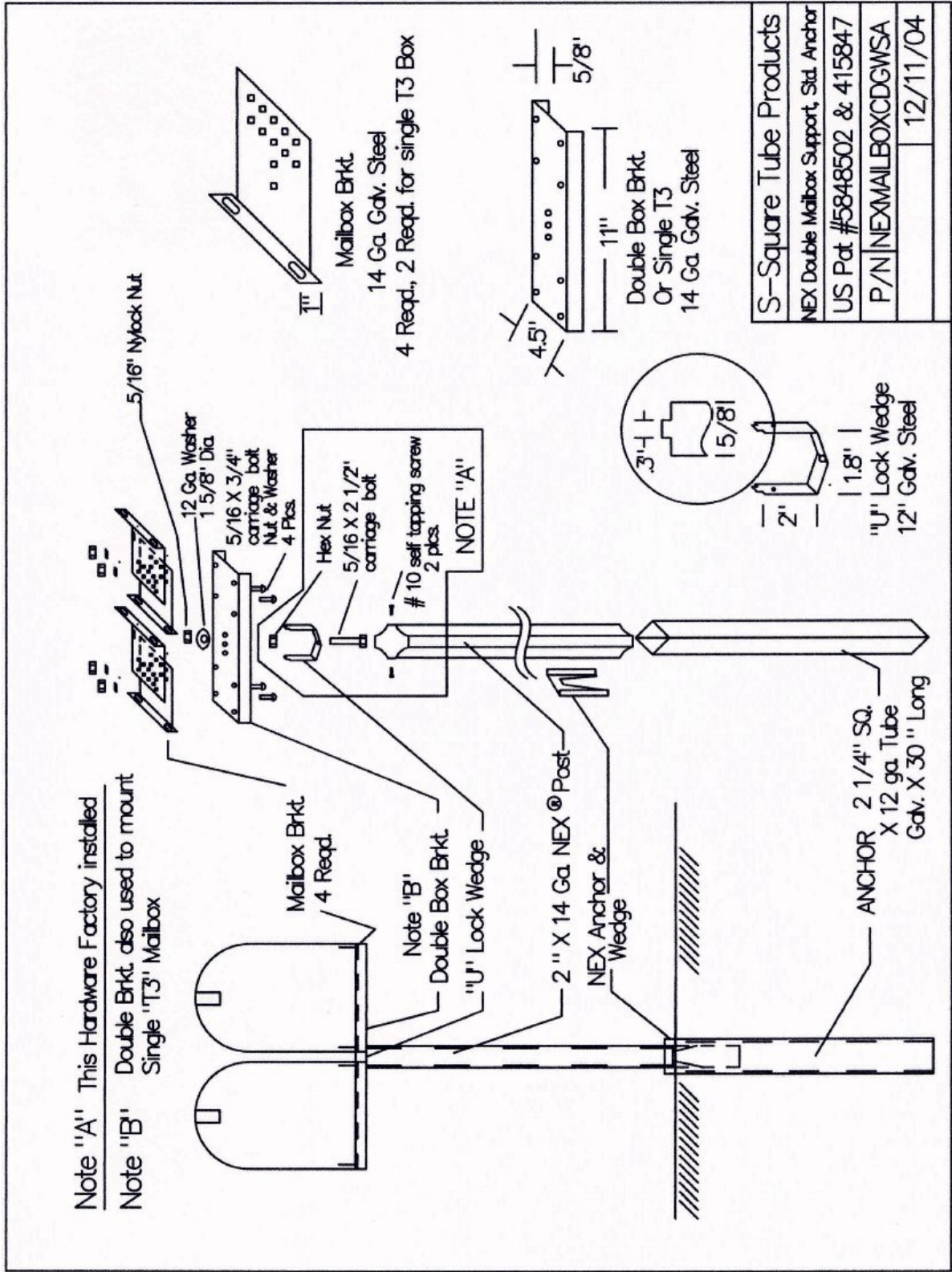

Figure 1. Details of the S-Square® Dual Mailbox System.



Figure 2. S-Square® Dual Mailbox System before Test No. 452109-9.

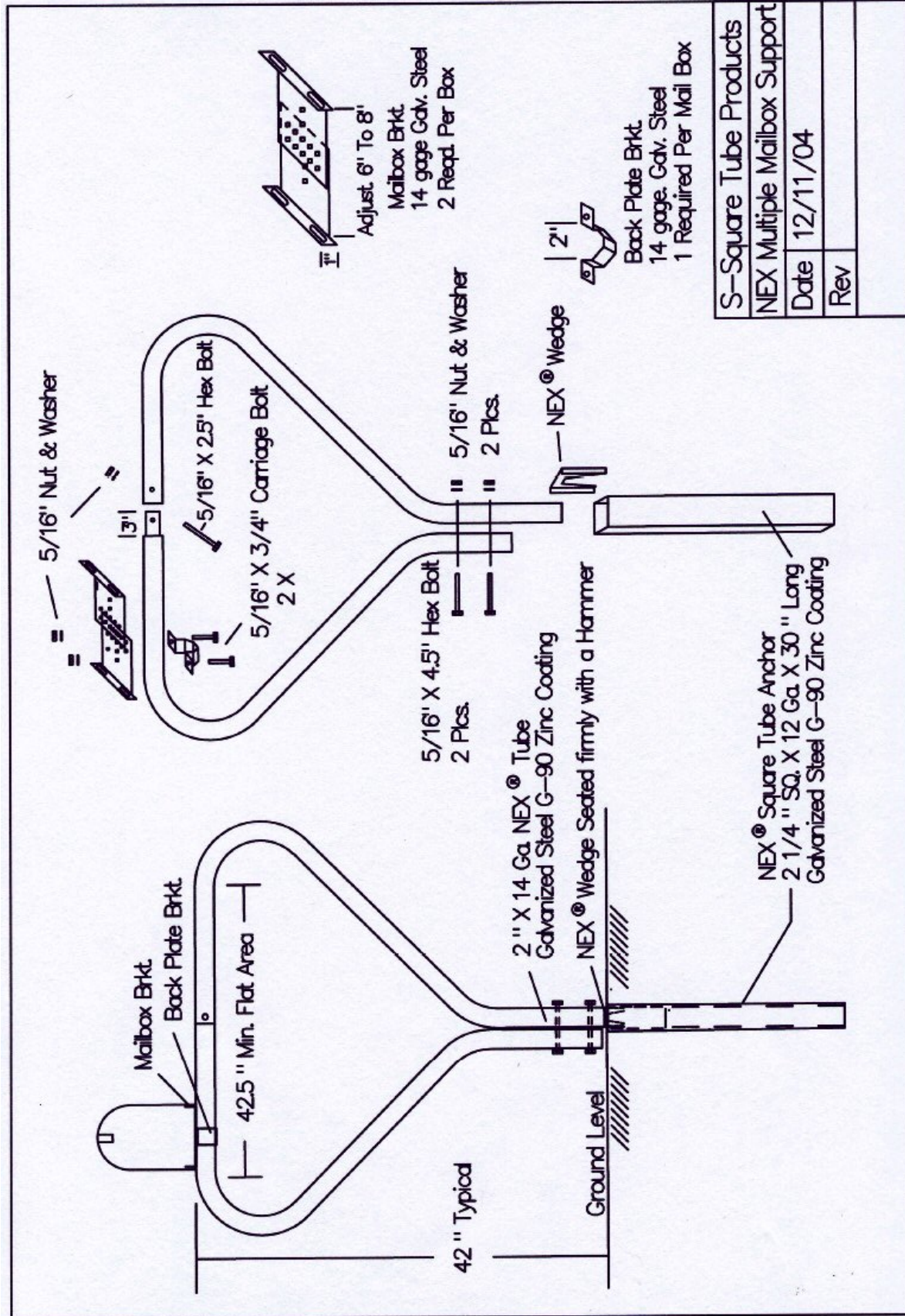

Figure 3. Details of the S-Square® Multiple Mailbox System.



Figure 4. S-Square® Multiple Mailbox System before Test No. 452109-10.

CRASH TEST CONDITIONS

NCHRP Report 350 recommends two tests for test level 3 evaluation of breakaway support structures such as mailboxes. The impact conditions and objective of each test is summarized below:

NCHRP Report 350 test designation 3-60: This test involves an 1806-lb passenger vehicle (820C) impacting the support structure at a nominal speed of 21.7 mi/h and an angle ranging from 0-20 degrees. The purpose of this test is to evaluate the breakaway, fracture, or yielding mechanism of the support, as well as occupant risk.

NCHRP Report 350 test designation 3-61: This test involves an 820C vehicle impacting the support structure at a nominal speed of 62.1 mi/h and an angle ranging from 0-20 degrees. The test is intended to evaluate vehicle and test article trajectory and occupant risk.

The results of all the tests reported herein correspond to *NCHRP Report 350* test designation 3-61. Researchers considered this high-speed test to be the most critical condition for evaluating the impact performance of the S-Square® Tube Products, Inc. dual and multiple mailbox support systems. At the higher speed, there is more propensity for the mailbox to cause occupant compartment intrusion due to secondary contact of the mailbox with the windshield of the impacting vehicle.

All crash test, data analysis, and evaluation and reporting procedures followed under this project were in accordance with guidelines presented in *NCHRP Report 350*. [Appendix A](#) presents brief descriptions of these procedures.

EVALUATION CRITERIA

The crash tests performed were evaluated in accordance with *NCHRP Report 350*. As stated in *NCHRP Report 350*, “Safety performance of a highway appurtenance cannot be measured directly but can be judged on the basis of three factors: structural adequacy, occupant risk, and vehicle trajectory after collision.” Accordingly, researchers used the safety evaluation criteria from Table 5.1 of *NCHRP Report 350* to evaluate the crash tests reported herein.

CHAPTER 3. CRASH TEST RESULTS

TEST NO. 452109-9 (NCHRP REPORT 350 TEST DESIGNATION 3-61) ON THE S-SQUARE® DUAL MAILBOX SYSTEM

Test Vehicle

A 1995 Geo Metro, shown in [Figures 5 and 6](#), was used for the crash test. Test inertia weight of the vehicle was 1862 lb, and its gross static weight was 2028 lb. The height to the lower edge of the vehicle bumper was 15.75 inches, and height to the upper edge of the vehicle bumper was 20.25 inches. [Figure 19](#) in [Appendix B](#) gives additional dimensions and information on the vehicle. The vehicle was directed into the installation using the cable reverse tow and guidance system, and was released to be free-wheeling and unrestrained just prior to impact.

Soil and Weather Conditions

The test was performed on the morning of August 19, 2008. No rainfall occurred in the 10 days prior to the test. Moisture content of the soil in which the anchor sleeve was embedded was 6.2 percent. Weather conditions at the time of testing were as follows: Wind speed: 10 mi/h; Wind direction: 171 degrees with respect to the vehicle (vehicle was traveling in a northerly direction); Temperature: 85°F; Relative humidity: 77 percent.

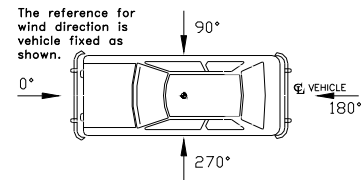

Test Description

The 820C vehicle, traveling at an impact speed of 60.6 mi/h, impacted the S-Square® dual mailbox system end on (i.e., 0 degrees) with the centerline of the mailbox support aligned with the right quarter-point of the vehicle and at 0 degrees. Upon contact, the support began to deform around the bumper, and at 0.014 s, the support began to pull out of the anchor sleeve. The nearest mailbox contacted the hood of the vehicle at 0.031 s, and the support began to rise above the hood at 0.067 s. At 0.168 s, the vehicle lost contact with the mailbox and support at an exit speed of 59.6 mi/h. As the vehicle exited the test site, the mailboxes were carried along in front of the vehicle. Brakes on the vehicle were applied 0.8 s after impact, and the vehicle subsequently came to rest 236 ft downstream of impact. [Figure 20](#) in [Appendix C](#) shows sequential photographs of the test period.



Figure 5. Vehicle/Installation Geometrics for Test No. 452109-9.



Figure 6. Vehicle before Test No. 452109-9.

Damage to Test Installation

The S-Square® dual mailbox support pulled out of the anchor sleeve, as shown in [Figures 7 and 8](#). The ground socket moved 0.25 inch downstream through the soil, and the downstream edge of the sleeve was deformed. The support post was deformed at bumper height and at groundline, and came to rest 70 ft downstream of impact. The mailboxes separated from the support, were collapsed, and came to rest 131 ft downstream of impact.

Vehicle Damage

[Figure 9](#) shows the damage to the 820C vehicle. The front bumper, hood, and right front fender were slightly deformed. The hood sustained a dent just below the windshield on the passenger side measuring 10.25 inches × 20.86 inches × 0.16 inch deep. No occupant compartment deformation occurred. Photographs of the interior of the vehicle are shown in [Figure 10](#). Exterior crush and occupant compartment measurements are presented in [Appendix B, Tables 3 and 4](#).

Occupant Risk Factors

Data from the accelerometer, located at the vehicle center of gravity, were digitized for evaluation of occupant risk. In the longitudinal direction, no occupant contact occurred, and the maximum 0.050-s average acceleration was -1.0 G between 0.002 and 0.052 s. In the lateral direction, no occupant impact contact occurred, and the maximum 0.050-s average was -0.8 G between 0.006 and 0.056 s. [Figure 11](#) presents these data and other pertinent information from the test. [Figures 22 through 28](#) in [Appendix D](#) present the vehicle angular displacements and accelerations versus time traces.

Assessment of Test Results

An assessment of the test based on the applicable *NCHRP Report 350* safety evaluation criteria is provided below.

Structural Adequacy

B. The test article should readily activate in a predictable manner by breaking away, fracturing, or yielding.

Result: The S-Square® Dual Mailbox System readily activated by deforming and pulling out of the anchor sleeve. (PASS)



Figure 7. After Impact Trajectory Path for Test No. 452109-9.



Figure 8. Installation after Test No. 452109-9.



Figure 9. Vehicle after Test No. 452109-9.



Figure 10. Interior of Vehicle for Test No. 452109-9.

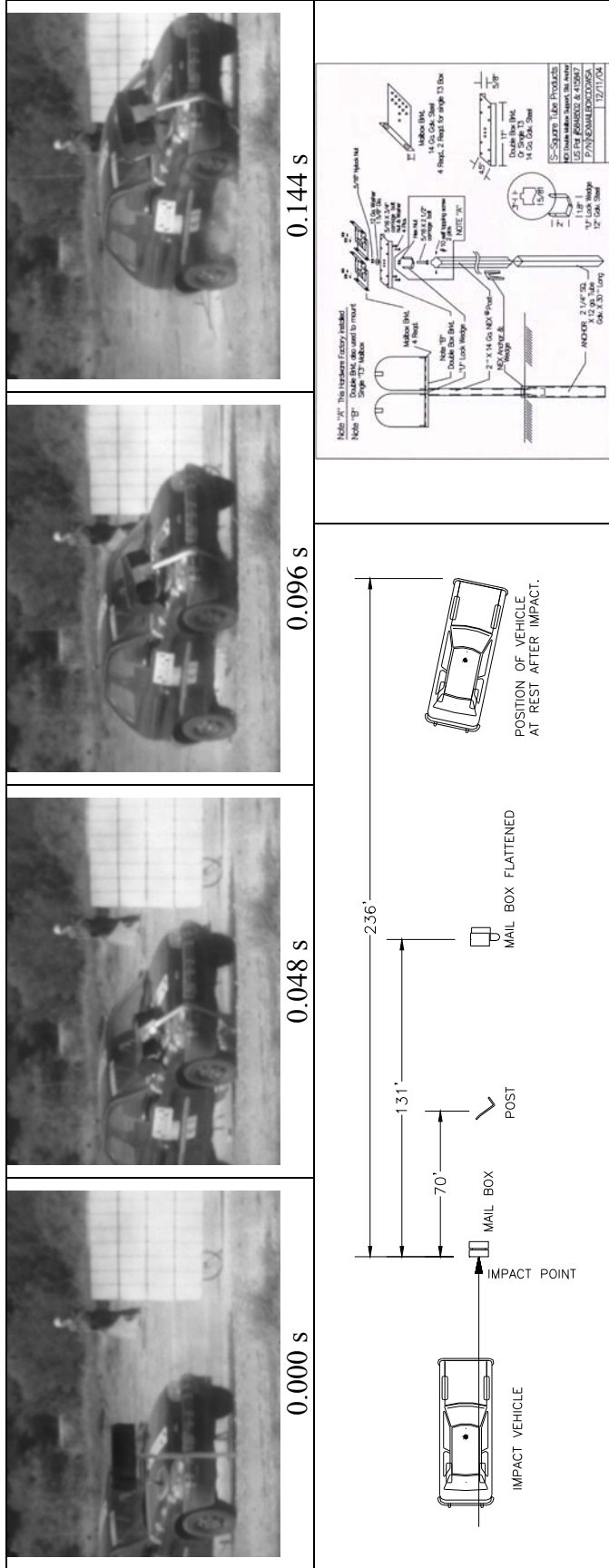

General Information	Texas Transportation Institute	Impact Conditions	Test Article Debris Scatter
Test Agency.....	452109-9	Speed.....	Longitudinal..... 131 ft
Test No.....	2009-08-19	Angle.....	Lateral..... 0 ft
Test Article	Mailbox	Exit Conditions	Vehicle Damage
Type.....	S-Square® Dual Mailbox Support	Speed.....	Exterior.....
Name.....	42 inches to bottom of mailboxes	Angle.....	VDS..... 12FR2
Installation Height.....	14 ga. steel tube support; 12 ga. steel	Occupant Risk Values	CDC..... 12FFREN2
Material or Key Elements.....	ground sleeve; two #2 mailboxes	Impact Velocity.....	Maximum Exterior.....
Soil Type and Condition	NCHRP Report 350 Standard Soil, Dry	Longitudinal.....	Vehicle Crush..... 0.16 inch
Test Vehicle		Lateral.....	Interior.....
Type.....	Production	THIV.....	OCDI..... RF0000000
Designation.....	820C	Ridedown Accelerations	Maximum Occupant Compartment
Model.....	1995 Geo Metro	Longitudinal.....	Deformation..... 0
Mass		Lateral.....	Post-Impact Behavior
Curb.....	1845 lb	PHD.....	(during 1.7 sec after impact)
Test Inertial.....	1862 lb	ASI.....	Max. Yaw Angle..... 11 degrees
Dummy.....	166 lb	Max. 0.050-s Average.....	Max. Pitch Angle..... -8 degrees
Gross Static.....	2028 lb	Longitudinal.....	Max. Roll Angle..... -6 degrees
		Lateral.....	
		Vertical.....	

Figure 11. Summary of Results for NCHRP Report 350 Test 3-61 on the S-Square® Dual Mailbox System.

Occupant Risk

D. *Detached elements, fragments, or other debris from the test article should not penetrate or show potential for penetrating the occupant compartment, or present an undue hazard to other traffic, pedestrians, or personnel in a work zone. Deformation of, or intrusions into, the occupant compartment that could cause serious injuries should not be permitted.*

Result: The support pulled out of the anchor sleeve as designed and did not penetrate or show potential to penetrate the occupant compartment, or to present undue hazard to others in the area. No occupant compartment deformation occurred. (PASS)

F. *The vehicle should remain upright during and after collision although moderate roll, pitching, and yawing are acceptable.*

Result: The 820C vehicle remained upright during and after the collision event. (PASS)

H. *Occupant impact velocities should satisfy the following:*
Longitudinal and Lateral Occupant Impact Velocity – m/s

	<u>Preferred</u>	<u>Maximum</u>
3	[9.8 ft/s]	5 [16.4 ft/s]

Result: No occupant impact occurred. (PASS)

I. *Occupant ridedown accelerations should satisfy the following:*
Longitudinal and Lateral Occupant Ridedown Accelerations – g’s

	<u>Preferred</u>	<u>Maximum</u>
	15	20

Result: No occupant contact occurred. (PASS)

Vehicle Trajectory

K. *After collision, it is preferable that the vehicle’s trajectory not intrude into adjacent traffic lanes.*

Result: The 820C vehicle did not intrude into adjacent traffic lanes. (PASS)

N. *Vehicle trajectory behind the test article is acceptable.*

Result: The 820C vehicle came to rest 236 ft downstream of impact. (PASS)

The following supplemental evaluation factors and terminology, as presented in the Federal Highway Administration (FHWA) memo entitled “ACTION: Identifying Acceptable Highway Safety Features,” were used for visual assessment of test results (2). Factors underlined below pertain to the results of the crash test reported herein.

Passenger Compartment Intrusion

1. Windshield Intrusion
 - a. No windshield contact
 - b. Windshield contact, no damage
 - c. Windshield contact, no intrusion
 - d. Device embedded in windshield, no significant intrusion
 - e. Complete intrusion into passenger compartment
 - f. Partial intrusion into passenger compartment
 2. Body Panel Intrusion
- yes or no

Loss of Vehicle Control

1. Physical loss of control
2. Loss of windshield visibility
3. Perceived threat to other vehicles
4. Debris on pavement

Physical Threat to Workers or Other Vehicles

1. Harmful debris that could injure workers or others in the area
 2. Harmful debris that could injure occupants in other vehicles
- The support with mailboxes pulled out of the anchor sleeve and was carried along with the vehicle. Weight of the detached elements was 24 lb.

Vehicle and Device Condition

1. Vehicle Damage
 - a. None
 - b. Minor scrapes, scratches or dents
 - c. Significant cosmetic dents
 - d. Major dents to grill and body panels
 - e. Major structural damage
2. Windshield Damage
 - a. None
 - b. Minor chip or crack
 - c. Broken, no interference with visibility
 - d. Broken or shattered, visibility restricted but remained intact
 - e. Shattered, remained intact but partially dislodged
 - f. Large portion removed
 - g. Completely removed
3. Device Damage
 - a. None
 - b. Superficial
 - c. Substantial, but can be straightened
 - d. Substantial, replacement parts needed for repair
 - e. Cannot be repaired

TEST NO. 452109-10 (NCHRP REPORT 350 TEST DESIGNATION 3-61) ON THE S-SQUARE® MULTIPLE MAILBOX SYSTEM

Test Vehicle

A 1995 Geo Metro, shown in Figures 12 and 13, was used for the crash test. Test inertia weight of the vehicle was 1862 lb, and its gross static weight was 2028 lb. The height to the lower edge of the vehicle bumper was 15.75 inches, and height to the upper edge of the vehicle bumper was 20.25 inches. Figure 19 in Appendix B gives additional dimensions and information on the vehicle. The vehicle was directed into the installation using the cable reverse tow and guidance system, and was released to be free-wheeling and unrestrained just prior to impact.

Soil and Weather Conditions

The test was performed on the afternoon of August 19, 2009. No rainfall occurred in the 10 days prior to the test. Moisture content of the soil in which the anchor sleeve was installed was 6.2 percent. Weather conditions at the time of testing were as follows: Wind speed: 14 mi/h; Wind direction: 171 degrees with respect to the vehicle (vehicle was traveling in a northerly direction); Temperature: 92°F; Relative humidity: 49 percent.

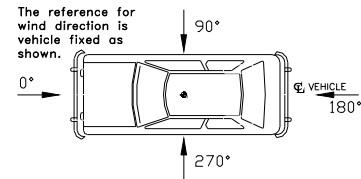

Test Description

The 820C vehicle, traveling at an impact speed of 61.9 mi/h, impacted the S-Square® multiple mailbox system end on (0 degrees) with the centerline of the mailbox support aligned with the right quarter-point of the vehicle. The vehicle contacted the support at 18.5 inches above the ground. Upon impact, the support began to deform around the bumper, and at 0.010 s, the support began to pull out of the anchor sleeve. The mailbox nearest the vehicle began to separate from the upper portion of the support at 0.017 s, but it did not become completely separated from the support. The support pulled completely out of the ground socket at 0.024 s and began rotating upward. The partially loose mailbox contacted the hood of the vehicle near the windshield at 0.046 s. At 0.138 s, the vehicle lost contact with the mailbox and had an exit speed of 61.5 mi/h. As the vehicle exited the test site, the mailboxes and support carried over the top of the vehicle. Brakes on the vehicle were applied at 0.062 s, and the vehicle came to rest 234 ft downstream of impact. Figure 21 in Appendix C shows sequential photographs of the test period.



Figure 12. Vehicle/Installation Geometrics for Test No. 452109-10.



Figure 13. Vehicle before Test No. 452109-10.

Damage to Test Installation

The S-Square® multiple mailbox support pulled out of the anchor sleeve, as shown in Figures 14 and 15. The sleeve moved 0.5 inch downstream through the soil and was deformed on the downstream edge. The support was deformed at bumper height, and came to rest 131 ft downstream of impact and 3 ft to the left of centerline. The mailboxes remained attached to the support.

Vehicle Damage

Damage to the vehicle is shown in Figure 16. The front bumper was scuffed and the hood was deformed over an area measuring 23.6 inches × 1.2 inches and 0.6 inches deep. The windshield was shattered over an area measuring 26.8 inches × 9.8 inches with a maximum depth of 1.1 inches. Visibility was not obscured by the damage to the windshield. Maximum exterior crush to the vehicle was 1.1 inches in the lower left quarter of the windshield. Other than the windshield deformation, no other occupant compartment deformation occurred. Photographs of the interior of the vehicle are shown in Figure 17. Exterior crush and occupant compartment measurements are presented in Appendix B, Tables 5 and 6.

Occupant Risk Factors

Data from the accelerometer, located at the vehicle center of gravity, were digitized for evaluation of occupant risk. In the longitudinal direction, the occupant impact velocity was 3.0 ft/s at 0.482 s; the highest 0.010-s occupant ridedown acceleration was -1.4 G from 0.869 to 0.879 s, and the maximum 0.050-s average acceleration was -1.2 G between 0.000 and 0.050 s. In the lateral direction, the occupant impact velocity was 3.3 ft/s at 0.482 s; the highest 0.010-s occupant ridedown acceleration was 0.4 G from 1.654 to 1.664 s, and the maximum 0.050-s average was -0.7 G between 0.039 and 0.089 s. Figure 18 presents these data and other pertinent information from the test. Figures 29 through 35 in Appendix D present the vehicle angular displacements and accelerations versus time traces.

Assessment of Test Results

An assessment of the test based on the applicable *NCHRP Report 350* safety evaluation criteria is provided below.

Structural Adequacy

B. *The test article should readily activate in a predictable manner by breaking away, fracturing, or yielding.*

Result: The S-Square® multiple mailbox support yielded to the 820C vehicle by pulling out of the anchor sleeve as designed. (PASS)



Figure 14. After Impact Trajectory Path for Test No. 452109-10.



Figure 15. Installation after Test No. 452109-10.



Figure 16. Vehicle after Test No. 452109-10.



Figure 17. Interior of Vehicle for Test No. 452109-10.

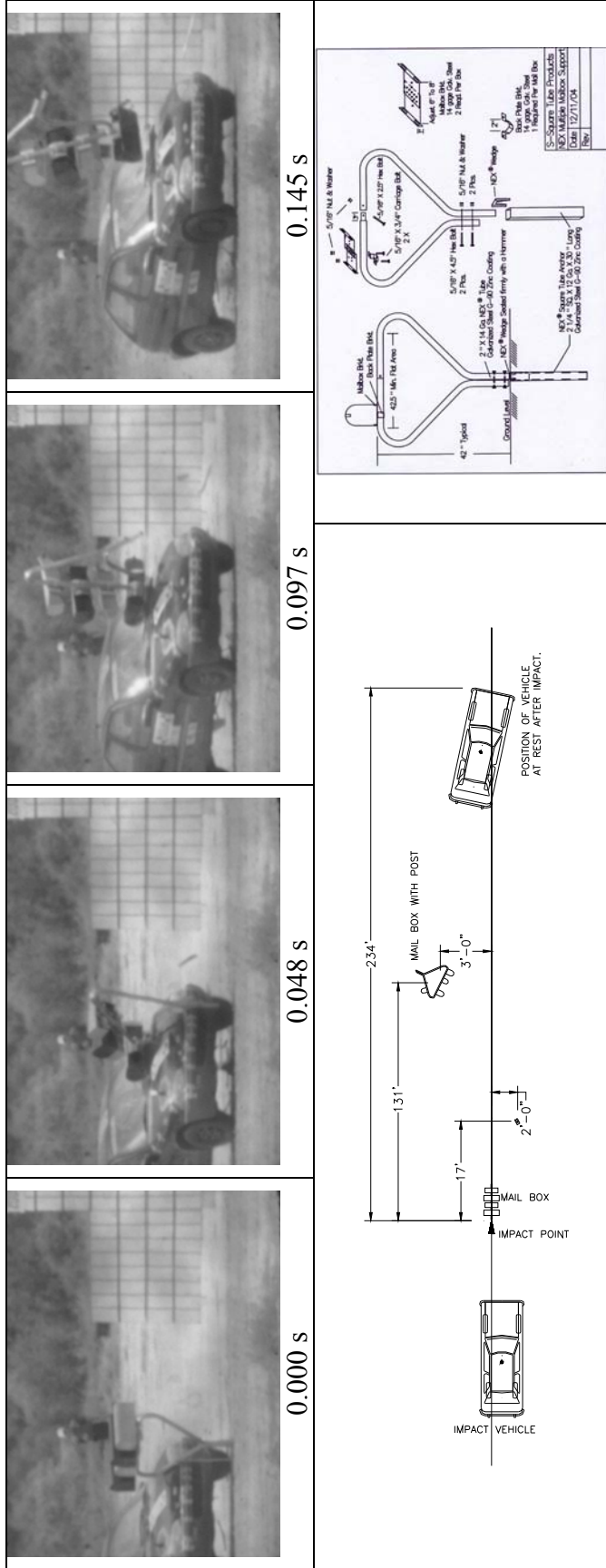

General Information	Texas Transportation Institute	Impact Conditions	Speed61.9 mi/h
Test Agency	452109-10	Angle	0 degrees
Test No.	2009-08-19	Exit Conditions	Speed
Date		Speed	61.5 mi/h
Test Article	Mailbox Support	Angle	0 degrees
Type	S-Square® Dual Mailbox Support	Occupant Risk Values	
Name	42 inches to bottom of mailboxes	Impact Velocity	
Installation Length (ft (m))	14 ga. steel support; 12 ga. ground sleeve; two #2 and two #1 mailboxes	Longitudinal	3.0 ft/s
Material or Key Elements	NCHRP Report 350 Standard Soil, Dry	Lateral	3.3 ft/s
Soil Type and Condition		THIV	4.7 km/h
Test Vehicle		Ridedown Accelerations	
Type	Production	Longitudinal	-1.4 G
Designation	820C	Lateral	0.4 G
Model	1995 Geo Metro	PHD	1.4 G
Mass (lb (kg))		ASI	0.13
Curb	1845 lb	Max. 0.050-s Average	
Test Inertial	1862 lb	Longitudinal	-1.2 G
Dummy	166 lb	Lateral	-0.7 G
Gross Static	2028 lb	Vertical	1.0 G

Figure 18. Summary of Results for NCHRP Report 350 Test 3-61 on the S-Square® Multiple Mailbox System.

Occupant Risk

D. *Detached elements, fragments, or other debris from the test article should not penetrate or show potential for penetrating the occupant compartment, or present an undue hazard to other traffic, pedestrians, or personnel in a work zone. Deformation of, or intrusions into, the occupant compartment that could cause serious injuries should not be permitted.*

Result: The support and mailboxes pulled out of the anchor sleeve as designed and did not penetrate or show potential to penetrate the occupant compartment, or to present undue hazard to others in the area. Maximum occupant compartment deformation was 1.1 inches in the windshield. (PASS)

F. *The vehicle should remain upright during and after collision although moderate roll, pitching, and yawing are acceptable.*

Result: The 820C vehicle remained upright and stable throughout the collision period and after exiting the test site. (PASS)

H. *Occupant impact velocities should satisfy the following:*

<u>Longitudinal and Lateral Occupant Impact Velocity – m/s</u>	
<u>Preferred</u>	<u>Maximum</u>
3	5 [16.4 ft/s]
[9.8 ft/s]	

Result: Longitudinal occupant impact velocity was 3.0 ft/s, and lateral occupant impact velocity was 3.3 ft/s. (PASS)

I. *Occupant ridedown accelerations should satisfy the following:*

<u>Longitudinal and Lateral Occupant Ridedown Accelerations – g's</u>	
<u>Preferred</u>	<u>Maximum</u>
15	20

Result: Longitudinal ridedown acceleration was -1.4 G, and lateral ridedown acceleration was 0.4 G. (PASS)

Vehicle Trajectory

K. *After collision, it is preferable that the vehicle's trajectory not intrude into adjacent traffic lanes.*

Result: The 820C vehicle did not intrude into adjacent traffic lanes. (PASS)

N. *Vehicle trajectory behind the test article is acceptable.*

Result: The vehicle came to rest 234 ft toward the field side of the installation. (PASS)

The following supplemental evaluation factors and terminology, as presented in the FHWA memo entitled “ACTION: Identifying Acceptable Highway Safety Features,” were used for visual assessment of test results (2). Factors underlined below pertain to the results of the crash test reported herein.

Passenger Compartment Intrusion

- | | |
|---|---|
| 1. <i>Windshield Intrusion</i> | |
| a. <i>No windshield contact</i> | e. <i>Complete intrusion into passenger compartment</i> |
| b. <i>Windshield contact, no damage</i> | f. <i>Partial intrusion into passenger compartment</i> |
| c. <u><i>Windshield contact, no intrusion</i></u> | |
| d. <i>Device embedded in windshield, no significant intrusion</i> | |
| 2. <i>Body Panel Intrusion</i> | yes or <u>no</u> |

Loss of Vehicle Control

- | | |
|---|--|
| 1. <i>Physical loss of control</i> | 3. <i>Perceived threat to other vehicles</i> |
| 2. <i>Loss of windshield visibility</i> | 4. <u><i>Debris on pavement</i></u> |

Physical Threat to Workers or Other Vehicles

1. *Harmful debris that could injure workers or others in the area*
2. *Harmful debris that could injure occupants in other vehicles*
The support with mailboxes pulled out of the anchor sleeve and carried over the vehicle. Weight of the detached elements was 49 lb.

Vehicle and Device Condition

- | | |
|--|--|
| 1. <i>Vehicle Damage</i> | |
| a. <i>None</i> | d. <i>Major dents to grill and body panels</i> |
| b. <i>Minor scrapes, scratches or dents</i> | e. <i>Major structural damage</i> |
| c. <u><i>Significant cosmetic dents</i></u> | |
| 2. <i>Windshield Damage</i> | |
| a. <i>None</i> | e. <i>Shattered, remained intact but partially dislodged</i> |
| b. <i>Minor chip or crack</i> | f. <i>Large portion removed</i> |
| c. <u><i>Broken, no interference with visibility</i></u> | g. <i>Completely removed</i> |
| d. <i>Broken or shattered, visibility restricted but remained intact</i> | |
| 3. <i>Device Damage</i> | |
| a. <i>None</i> | d. <i>Substantial, replacement parts needed for repair</i> |
| b. <i>Superficial</i> | e. <u><i>Cannot be repaired</i></u> |
| c. <i>Substantial, but can be straightened</i> | |

CHAPTER 4. SUMMARY AND CONCLUSIONS

SUMMARY OF TEST RESULTS

Two full-scale crash tests were performed in accordance with *NCHRP Report 350* guidelines to evaluate the impact performance of the S-Square® dual and multiple mailbox supports. The performance of each system is summarized below.

Dual Mailbox Mount

The S-Square® Dual-Mailbox Mount yielded to the vehicle by pulling out of the anchor sleeve. The support did not penetrate or show potential for penetrating the occupant compartment, or present undue hazard to others in the area. No occupant compartment deformation occurred. The S-Square® Dual-Mailbox Mount impacted the hood of the vehicle and was carried along with the vehicle. The vehicle remained upright during and after the collision event. No occupant contact occurred. The vehicle traveled straightforward and did not intrude into adjacent traffic lanes. The vehicle came to rest behind the test installation.

Multiple-Mailbox Mount

The S-Square® Multiple-Mailbox Mount yielded to the vehicle by pulling out of the anchor sleeve. One of the mailbox units contacted and shattered the windshield over an area measuring 26.8 inches x 9.8 inches with a maximum depth of 1.1 inches. However, visibility was not obscured, and the support did not penetrate or show potential for penetrating the occupant compartment. The vehicle remained upright during and after the collision event. Occupant risk factors were within recommended limits. The vehicle traveled straightforward and did not intrude into adjacent traffic lanes. The vehicle came to rest behind the installation.

CONCLUSIONS

Tables 1 and 2 summarize the test results and the final assessment of the researchers for each of the specified criterion for the dual mailbox mount and multiple mailbox mount, respectively. Based on these crash test results, the researchers conclude that the S-Square® dual mailbox and multiple-mailbox supports successfully passed all requirements of the *NCHRP Report 350* safety evaluation criteria and are ready for field installation.

Table 1. Performance Evaluation Summary for NCHRP Report 350 Test 3-61 on the S-Square® Dual Mailbox System.

Test Agency: Texas Transportation Institute		Test No.: 452109-9	Test Date: 2009-08-19
NCHRP Report 350 Test 3-61 Evaluation Criteria		Test Results	Assessment
Structural Adequacy			
<i>B. The test article should readily activate in a predictable manner by breaking away, fracturing, or yielding.</i>		The S-Square® dual mailbox support yielded to the 820C vehicle and pulled out of the anchor sleeve as designed.	Pass
Occupant Risk			
<i>D. Detached elements, fragments, or other debris from the test article should not penetrate or show potential for penetrating the occupant compartment, or present an undue hazard to other traffic, pedestrians, or personnel in a work zone. Deformations of, or intrusions into, the occupant compartment that could cause serious injuries should not be permitted.</i>		The support pulled out of the anchor sleeve and did not penetrate or show potential to penetrate the occupant compartment, or to present undue hazard to others in the area. No occupant compartment deformation occurred.	Pass
<i>F. The vehicle should remain upright during and after collision although moderate roll, pitching, and yawing are acceptable.</i>		The 820C vehicle remained upright and stable throughout the collision period and after exiting the test site.	Pass
<i>H. Occupant impact velocities should satisfy the following:</i>		No occupant contact occurred.	Pass
	<i>Occupant Velocity Limits (m/s)</i>		
	<i>Component Preferred</i>	<i>Maximum</i>	
	<i>Longitudinal</i>	3 [9.8 ft/s]	5 [16.4 ft/s]
<i>I. Occupant ridedown accelerations should satisfy the following:</i>		No contact occurred.	Pass
	<i>Occupant Ridedown Acceleration Limits (g's)</i>		
	<i>Component Preferred</i>	<i>Maximum</i>	
	<i>Longitudinal and lateral</i>	15	20
Vehicle Trajectory			
<i>K. After collision, it is preferable that the vehicle's trajectory not intrude into adjacent traffic lanes.</i>		The 820C vehicle did not intrude into adjacent traffic lanes.	Pass*
<i>N. Vehicle trajectory behind the test article is acceptable.</i>		The vehicle came to rest 236 ft toward the field side of the installation.	Pass

* Criterion K is preferable, not required.

Table 2. Performance Evaluation Summary for NCHRP Report 350 Test 3-61 on the S-Square® Multiple Mailbox System.

Test Agency: Texas Transportation Institute		Test No.: 452109-10	Test Date: 2009-08-19
NCHRP Report 350 Test 3-61 Evaluation Criteria		Test Results	Assessment
Structural Adequacy			
<i>B. The test article should readily activate in a predictable manner by breaking away, fracturing, or yielding.</i>		The S-Square® dual mailbox support yielded to the 820C vehicle and pulled out of the anchor sleeve as designed.	Pass
Occupant Risk			
<i>D. Detached elements, fragments, or other debris from the test article should not penetrate or show potential for penetrating the occupant compartment, or present an undue hazard to other traffic, pedestrians, or personnel in a work zone. Deformations of, or intrusions into, the occupant compartment that could cause serious injuries should not be permitted.</i>		The support pulled out of the anchor sleeve and did not penetrate or show potential to penetrate the occupant compartment, or to present undue hazard to others in the area. No occupant compartment deformation occurred.	Pass
<i>F. The vehicle should remain upright during and after collision although moderate roll, pitching, and yawing are acceptable.</i>		The 820C vehicle remained upright and stable throughout the collision period and after exiting the test site.	Pass
H. Occupant impact velocities should satisfy the following:			
<i>Occupant Velocity Limits (m/s)</i>			
<i>Component Preferred</i>		<i>Maximum</i>	
<i>Longitudinal</i>	3 [9.8 ft/s]	5 [16.4 ft/s]	Pass
<i>I. Occupant ridedown accelerations should satisfy the following:</i>			
<i>Occupant Ridedown Acceleration Limits (g's)</i>			
<i>Component Preferred</i>		<i>Maximum</i>	
<i>Longitudinal and lateral</i>	15	20	Pass
Vehicle Trajectory			
<i>K. After collision, it is preferable that the vehicle's trajectory not intrude into adjacent traffic lanes.</i>		The 820C vehicle did not intrude into adjacent traffic lanes.	Pass*
<i>N. Vehicle trajectory behind the test article is acceptable.</i>		The vehicle came to rest 234 ft toward the field side of the installation.	Pass

* Criterion K is preferable, not required.

CHAPTER 5. IMPLEMENTATION STATEMENT

The S-Square® Dual Mailbox Mount has demonstrated acceptable impact performance and is considered suitable for implementation. The dual mailbox mount was successfully tested with two large (#2) mailboxes. Based on the results of this testing, the dual mailbox mount is also considered acceptable for use with any combination of small (#1) and large (#2) mailboxes. For example, the support can be used with two small mailboxes or one small mailbox and one large mailbox. Additionally, the same 2-inch, 14-gauge NEX® post can be used as a single mailbox mount with either a large (#2) or small (#1) mailbox attached. Implementation of the single and dual mailbox mounts can be achieved by revising TxDOT's Maintenance Standard Plan Sheets through the Maintenance Division.

The S-Square® Multiple-Mailbox Support has demonstrated acceptable impact performance and is considered suitable for implementation. The multiple mailbox mount was successfully tested in a configuration that included two small (#1) mailboxes weighing 3.4 lb each and two large (#2) mailboxes weighing 6 lb each. Total weight of the mailboxes was approximately 18.8 lb. Alternate mailbox arrangements are considered acceptable provided the total weight of the mailboxes does not exceed the total tested weight of 18.8 lb and sufficient space is available on the horizontal member of the support. For example, three large mailboxes (total weight 18 lb) or 5 small mailboxes (total weight 17 lb) would be considered acceptable alternatives to the tested configuration. Implementation of the multiple mailbox mount can be achieved by revising TxDOT's Maintenance Standard Plan Sheets through the Maintenance Division.

REFERENCES

1. H. E. Ross, Jr., D. L. Sicking, R. A. Zimmer, and J. D. Michie. *Recommended Procedures for the Safety Performance Evaluation of Highway Features*, National Cooperative Highway Research Program Report 350, Transportation Research Board, National Research Council, Washington, D.C., 1993.
2. Federal Highway Administration Memorandum from the Director, Office of Engineering, entitled: "ACTION: Identifying Acceptable Highway Safety Features," dated July 25, 1997.

APPENDIX A. CRASH TEST AND DATA ANALYSIS PROCEDURES

The crash test and data analysis procedures were in accordance with guidelines presented in *NCHRP Report 350*. Brief descriptions of these procedures are presented as follows.

ELECTRONIC INSTRUMENTATION AND DATA PROCESSING

The test vehicle was instrumented with three solid-state angular rate transducers to measure roll, pitch, and yaw rates; a triaxial accelerometer near the vehicle center of gravity (c.g.) to measure longitudinal, lateral, and vertical acceleration levels; and a backup biaxial accelerometer in the rear of the vehicle to measure longitudinal and lateral acceleration levels. These accelerometers were ENDEVCO[®] Model 2262CA, piezoresistive accelerometers with a ± 100 g range.

The accelerometers are strain gage type with a linear millivolt output proportional to acceleration. Angular rate transducers are solid state, gas flow units designed for high-“g” service. Signal conditioners and amplifiers in the test vehicle increase the low-level signals to a ± 2.5 volt maximum level. The signal conditioners also provide the capability of a resistive calibration (R-cal) or shunt calibration for the accelerometers and a precision voltage calibration for the rate transducers. The electronic signals from the accelerometers and rate transducers are transmitted to a base station by means of a 15-channel, constant bandwidth, Inter-Range Instrumentation Group (I.R.I.G.), FM/FM telemetry link for recording and for display. Calibration signals from the test vehicle are recorded before the test and immediately afterwards. A crystal-controlled time reference signal is simultaneously recorded with the data. Wooden dowels actuate pressure-sensitive switches on the bumper of the impacting vehicle prior to impact by wooden dowels to indicate the elapsed time over a known distance to provide a measurement of impact velocity. The initial contact also produces an “event” mark on the data record to establish the instant of contact with the installation.

The multiplex of data channels, transmitted on one radio frequency, is received and demultiplexed onto a TEAC[®] instrumentation data recorder. After the test, the data are played back from the TEAC[®] recorder and digitized. A proprietary software program (WinDigit) converts the analog data from each transducer into engineering units using the R-cal and pre-zero values at 10,000 samples per second per channel. WinDigit also provides Society of Automotive Engineers (SAE) J211 class 180 phaseless digital filtering and vehicle impact velocity.

All accelerometers are calibrated annually according to the SAE J211 4.6.1 by means of an ENDEVCO[®] 2901, precision primary vibration standard. This device and its support instruments are returned to the factory annually for a National Institute of Standards Technology (NIST) traceable calibration. The subsystems of each data channel are also evaluated annually, using instruments with current NIST traceability, and the results are factored into the accuracy of the total data channel, per SAE J211. Calibrations and evaluations are made any time data are suspect.

The Test Risk Assessment Program (TRAP) uses the data from WinDigit to compute occupant/compartiment impact velocities, time of occupant/compartiment impact after vehicle impact, and the highest 10-millisecond (ms) average ridedown acceleration. WinDigit calculates change in vehicle velocity at the end of a given impulse period. In addition, WinDigit computes maximum average accelerations over 50-ms intervals in each of the three directions. For reporting purposes, the data from the vehicle-mounted accelerometers are filtered with a 60-Hz digital filter, and acceleration versus time curves for the longitudinal, lateral, and vertical directions are plotted using TRAP.

TRAP uses the data from the yaw, pitch, and roll rate transducers to compute angular displacement in degrees at 0.0001-s intervals and then plots yaw, pitch, and roll versus time. These displacements are in reference to the vehicle-fixed coordinate system with the initial position and orientation of the vehicle-fixed coordinate systems being initial impact.

ANTHROPOMORPHIC DUMMY INSTRUMENTATION

An Alderson Research Laboratories Hybrid II, 50th percentile male anthropomorphic dummy, restrained with lap and shoulder belts, was placed in the driver's position of the 820C vehicle. The dummy was uninstrumented

PHOTOGRAPHIC INSTRUMENTATION AND DATA PROCESSING

Photographic coverage of the test included three high-speed cameras: one overhead with a field-of-view perpendicular to the ground and directly over the impact point; one placed behind the installation at an angle; and a third placed to have a field-of-view parallel to and aligned with the installation at the downstream end. A flash bulb activated by pressure-sensitive tape switches was positioned on the impacting vehicle to indicate the instant of contact with the installation and was visible from each camera. The films from these high-speed cameras were analyzed on a computer-linked Motion Analyzer to observe phenomena occurring during the collision and to obtain time-event, displacement, and angular data. A 16-mm movie cine, a BetaCam, a VHS-format video camera and recorder, and still cameras were used to record and document conditions of the test vehicle and installation before and after the test.

TEST VEHICLE PROPULSION AND GUIDANCE

The test vehicle was towed into the test installation using a steel cable guidance and reverse tow system. A steel cable for guiding the test vehicle was tensioned along the path, anchored at each end, and threaded through an attachment to the front wheel of the test vehicle. An additional steel cable was connected to the test vehicle, passed around a pulley near the impact point, through a pulley on the tow vehicle, and then anchored to the ground such that the tow vehicle moved away from the test site. A 2-to-1 speed ratio between the test and tow vehicle existed with this system. Just prior to impact with the installation, the test vehicle was released to be free-wheeling and unrestrained. The vehicle remained free-wheeling, i.e., no steering or braking inputs, until the vehicle cleared the immediate area of the test site, at which time the vehicle's brakes were activated to bring it to a safe and controlled stop.

APPENDIX B. TEST VEHICLE PROPERTIES AND INFORMATION

Vehicle Inventory Number: 797

Date: 2009-08-19 Test No.: 452109-9 and 10 VIN No.: 2C1MR2297S6775336

Year: 1995 Make: Geo Model: Metro

Tire Inflation Pressure: 32 psi Odometer: 109330 Tire Size: 155/80R13

Describe any damage to the vehicle prior to test: _____

⊠ Denotes accelerometer location.

NOTES: _____

Engine Type: 4 cylinder

Engine CID: 4.3 liter

Transmission Type:

Auto
 Manual

Optional Equipment: _____

Dummy Data:

Type: 50th percentile male

Mass: 165 lb

Seat Position: Opposite Impact

Geometry (inches)

A	<u>62.60</u>	E	<u>23.62</u>	J	<u>25.59</u>	N	<u>54.53</u>	R	<u>15.35</u>
B	<u>31.10</u>	F	<u>147.83</u>	K	<u>20.25</u>	O	<u>53.54</u>	S	<u>22.05</u>
C	<u>93.11</u>	G	<u>33.61</u>	L	<u>4.72</u>	P	<u>22.44</u>	T	<u>39.76</u>
D	<u>55.91</u>	H	_____	M	<u>15.75</u>	Q	<u>14.37</u>	U	<u>96.06</u>

ALLOWABLE RANGE: B = 750 ±100 mm ; C = 2300 ±100 mm; F = 3700 ±200 mm; G = 800 ±150 mm; H = 550 ±50 mm; N = 1350 ±100 mm

ALLOWABLE RANGE: B = 29.5 ±4 inches ; C = 90.6 ±4 inches; F = 145.7 ±8 inches; G = 31.5 ±5.9 inches; H = 21.6 ±2 inches; N = 53.1 ±4 inches

Mass

(lb or kg)	<u>Curb</u>	<u>Test Inertial</u>	<u>Gross Static</u>	
M ₁	<u>1212</u>	<u>1190</u>	<u>1276</u>	Allowable Range
M ₂	<u>633</u>	<u>672</u>	<u>762</u>	1807 ±55 lb
M _{Total}	<u>1845</u>	<u>1862</u>	<u>2028</u>	820 ±25 kg 895 ±25 kg

Mass Distribution

(lb or kg): LF: 619 RF: 571 LR: 337 RR: 335

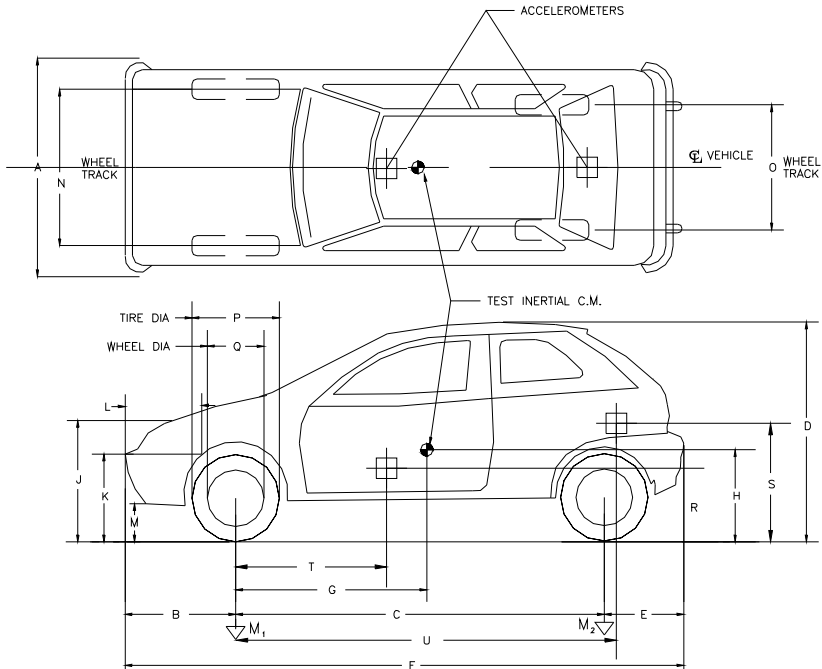

Figure 19. Vehicle Properties for Test No. 452109-9 and 10.

Table 4. Occupant Compartment Measurements for Test No. 452109-9.

Vehicle Inventory Number: 797

Date: 2009-08-19 Test No.: 452109-9 VIN No.: 2C1MR2297S6775336

Year: 1995 Make: Geo Model: Metro

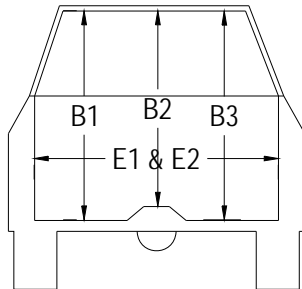
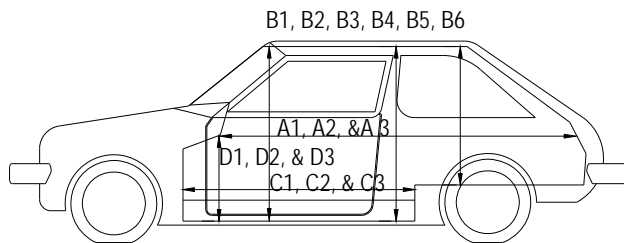
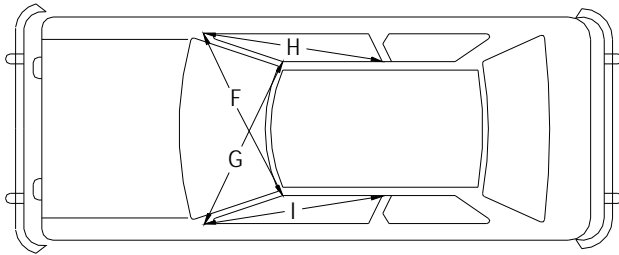

OCCUPANT COMPARTMENT DEFORMATION MEASUREMENT

	Before (inches)	After (inches)
A1	56.61	56.61
A2	78.74	78.74
A3	55.10	55.10
B1	37.99	37.99
B2	35.63	35.63
B3	37.99	37.99
B4	34.96	34.96
B5	35.04	35.04
B6	34.96	34.96
C1	23.23	23.23
C2	-----	-----
C3	24.41	24.41
D1	9.45	9.45
D2	-----	-----
D3	9.76	9.76
E1	47.83	47.83
E2	46.14	46.14
F	47.83	47.83
G	47.83	47.83
H	40.55	40.55
I	40.55	40.55
J*	47.24	47.24

*Lateral area across the cab from driver's side kickpanel to passenger's side kickpanel.

Table 5. Exterior Crush Measurements for Test No. 452109-10.

Vehicle Inventory Number: 797

Date: 2009-08-19 Test No.: 452109-10 VIN No.: 2C1MR2297S6775336

Year: 1995 Make: Geo Model: Metro

VEHICLE CRUSH MEASUREMENT SHEET¹

Complete When Applicable	
End Damage	Side Damage
Undeformed end width _____ Corner shift: A1 _____ A2 _____ End shift at frame (CDC) (check one) < 4 inches _____ ≥ 4 inches _____	Bowing: B1 _____ X1 _____ B2 _____ X2 _____ Bowing constant $\frac{X1 + X2}{2} = \underline{\hspace{2cm}}$

Note: Measure C₁ to C₆ from Driver to Passenger side in Front or Rear impacts – Rear to Front in Side Impacts.

Specific Impact Number	Plane* of C-Measurements	Direct Damage		Field L**	C ₁	C ₂	C ₃	C ₄	C ₅	C ₆	±D
		Width** (CDC)	Max*** Crush								
	Hood and windshield										
	Damage only										
	No measureable damage										
	Measurements recorded										
	in inches										

¹Table taken from National Accident Sampling System (NASS).

*Identify the plane at which the C-measurements are taken (e.g., at bumper, above bumper, at sill, above sill, at beltline, etc.) or label adjustments (e.g., free space).

Free space value is defined as the distance between the baseline and the original body contour taken at the individual C locations. This may include the following: bumper lead, bumper taper, side protrusion, side taper, etc. Record the value for each C-measurement and maximum crush.

**Measure and document on the vehicle diagram the beginning or end of the direct damage width and field L (e.g., side damage with respect to undamaged axle).

***Measure and document on the vehicle diagram the location of the maximum crush.

Note: Use as many lines/columns as necessary to describe each damage profile.

Table 6. Occupant Compartment Measurements for Test No. 452109-10.

Vehicle Inventory Number: 797

Date: 2009-08-19 Test No.: 452109-10 VIN No.: 2C1MR2297S6775336

Year: 1995 Make: Geo Model: Metro

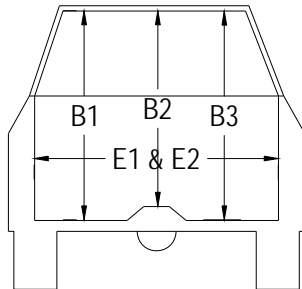
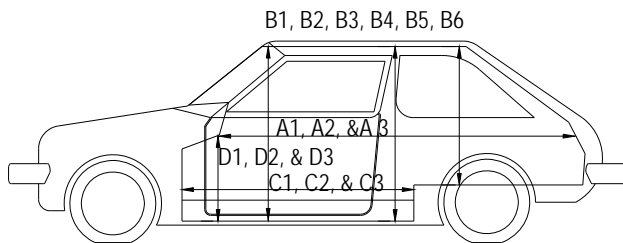
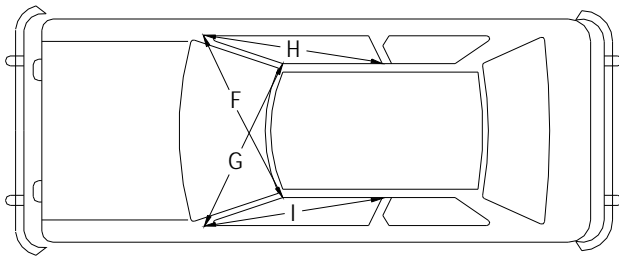

OCCUPANT COMPARTMENT DEFORMATION MEASUREMENT

	Before (inches)	After (inches)
A1	56.61	56.61
A2	78.74	78.74
A3	55.10	55.10
B1	37.99	37.99
B2	35.63	35.63
B3	37.99	37.99
B4	34.96	34.96
B5	35.04	35.04
B6	34.96	34.96
C1	23.23	23.23
C2	-----	-----
C3	24.41	24.41
D1	9.45	9.45
D2	-----	-----
D3	9.76	9.76
E1	47.83	47.83
E2	46.14	46.14
F	47.83	47.83
G	47.83	47.83
H	40.55	40.55
I	40.55	40.55
J*	47.24	47.24

*Lateral area across the cab from driver's side kickpanel to passenger's side kickpanel.

APPENDIX C. SEQUENTIAL PHOTOGRAPHS

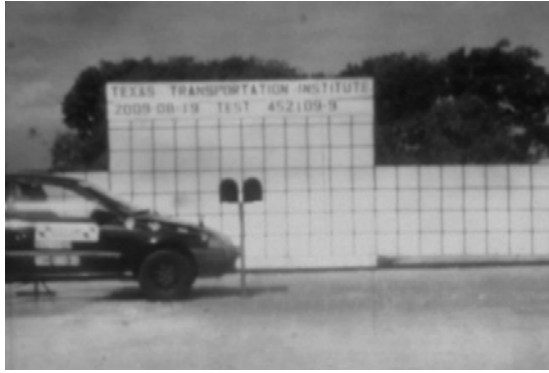

0.000 s

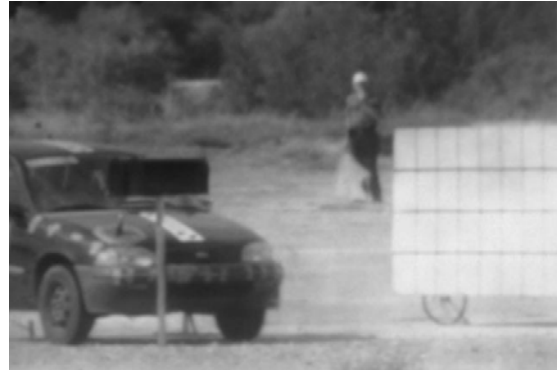

0.024 s



0.048 s



0.072 s



**Figure 20. Sequential Photographs for Test No. 452109-9
(Perpendicular and Frontal Oblique Views).**



0.096s



0.120 s



0.144 s



0.168 s



Figure 20. Sequential Photographs for Test No. 452109-9 (Perpendicular and Frontal Oblique) (Continued).



0.000 s



0.024 s



0.048 s



0.072 s



Figure 21. Sequential Photographs for Test No. 452109-10 (Perpendicular and Frontal Oblique Views).



0.097 s



0.121 s



0.145 s



0.169 s



**Figure 21. Sequential Photographs for Test No. 452109-10
(Perpendicular and Frontal Oblique) (Continued).**

**APPENDIX D. VEHICLE ANGULAR DISPLACEMENTS
AND ACCELERATIONS**

Roll, Pitch, and Yaw Angles

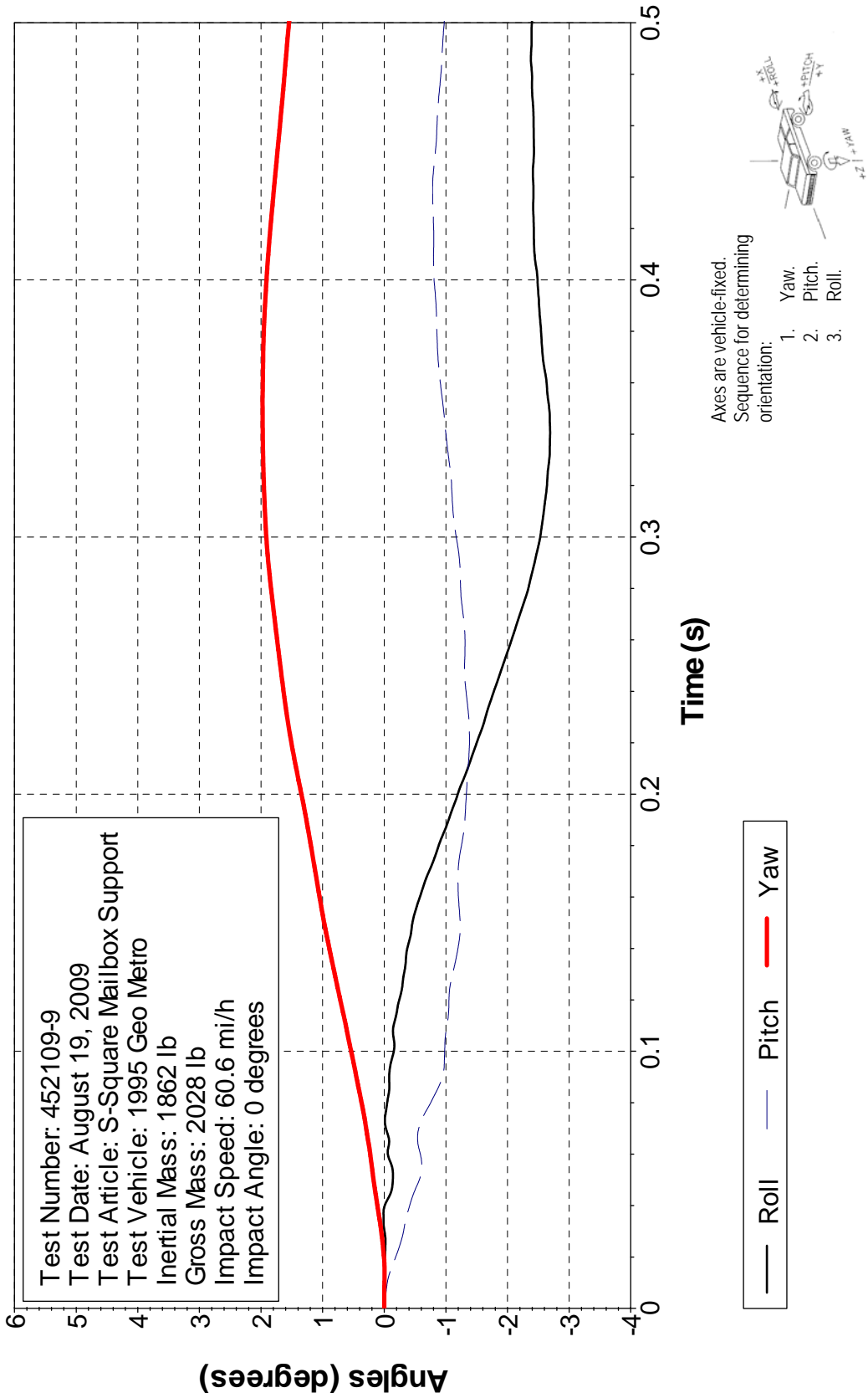

Figure 22. Vehicle Angular Displacements for Test No. 452109-9.

X Acceleration at CG

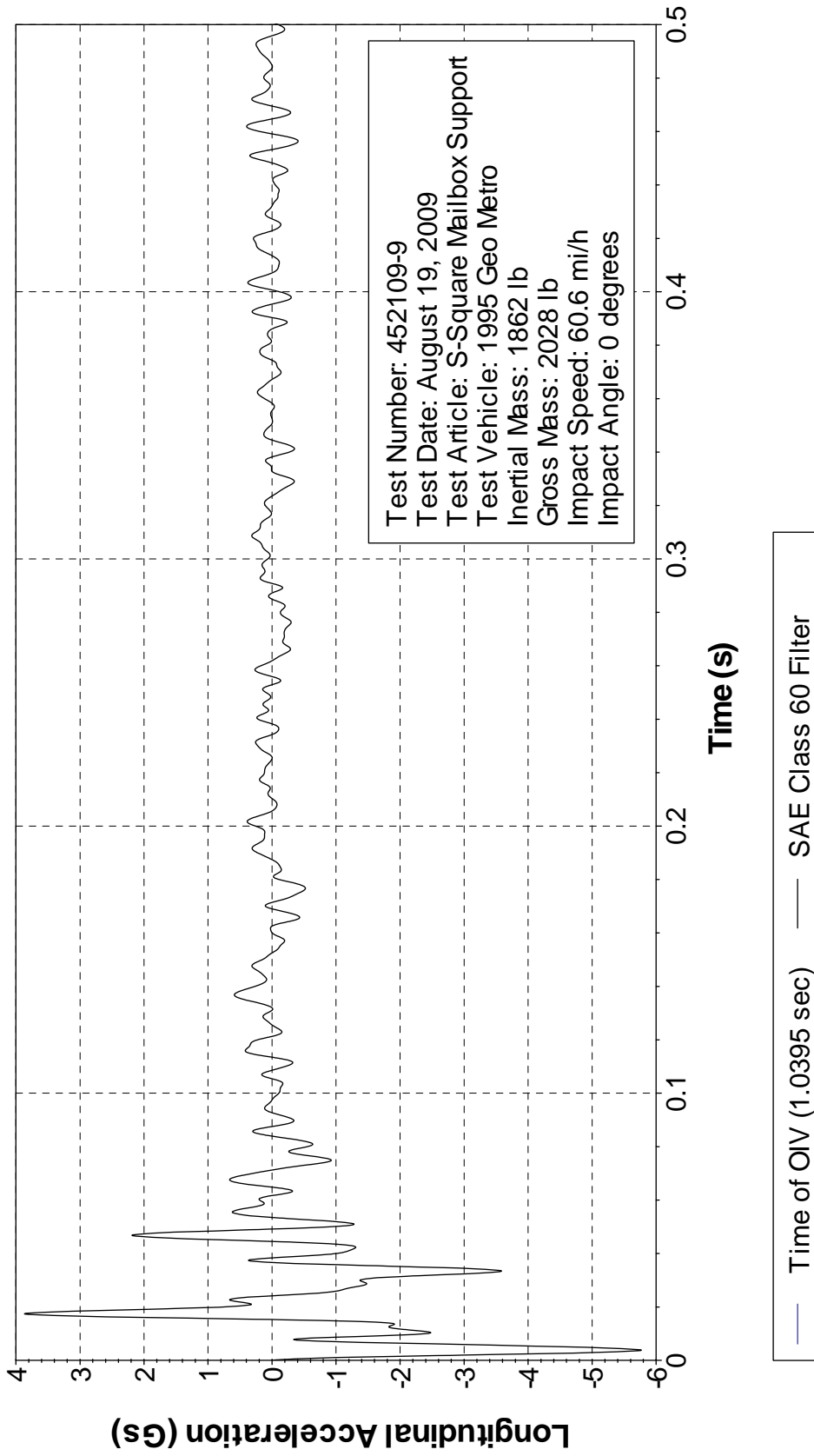

Figure 23. Vehicle Longitudinal Accelerometer Trace for Test No. 452109-9 (Accelerometer Located at Center of Gravity).

Y Acceleration at CG

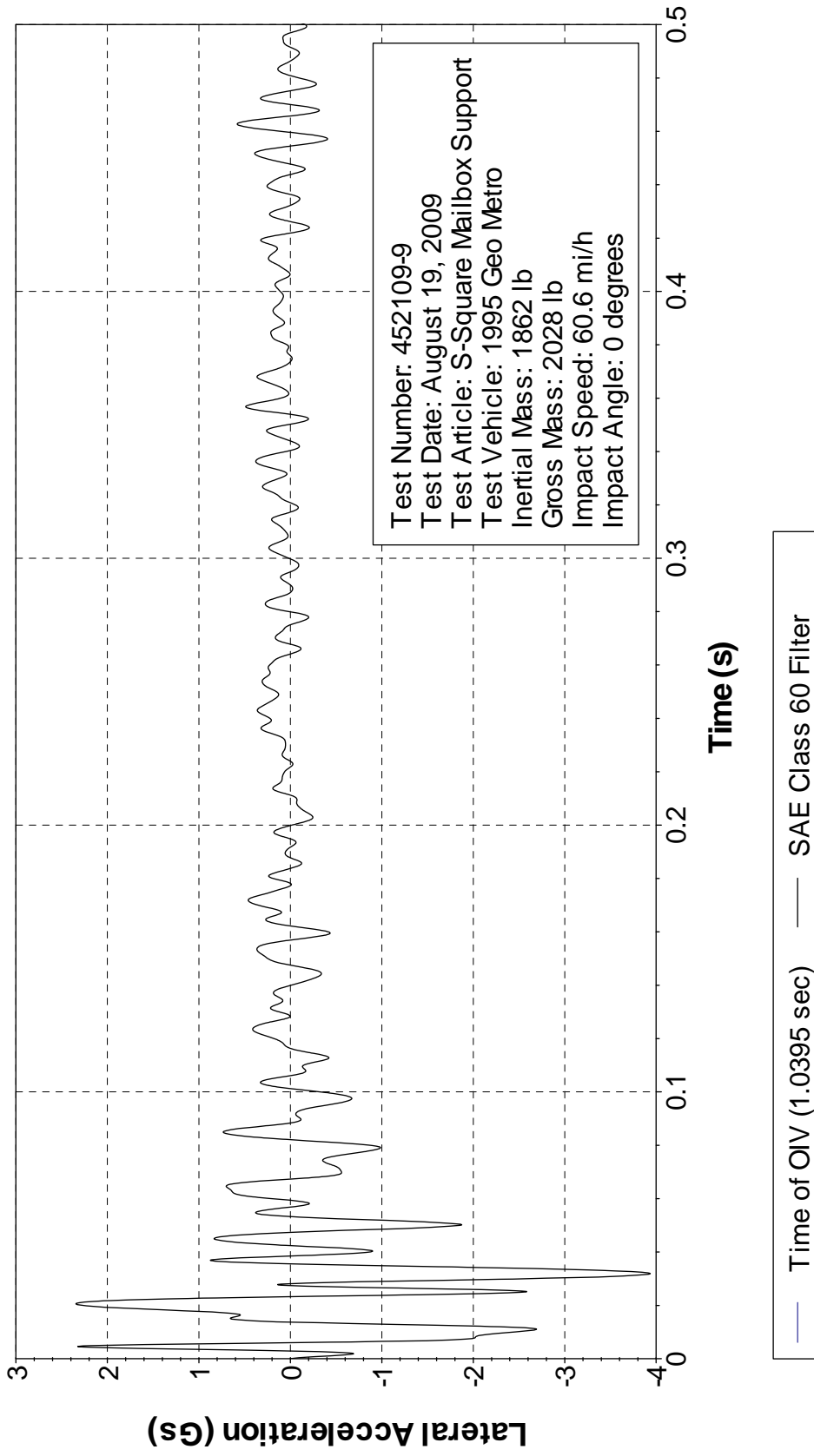

Figure 24. Vehicle Lateral Accelerometer Trace for Test No. 452109-9 (Accelerometer Located at Center of Gravity).

Z Acceleration at CG

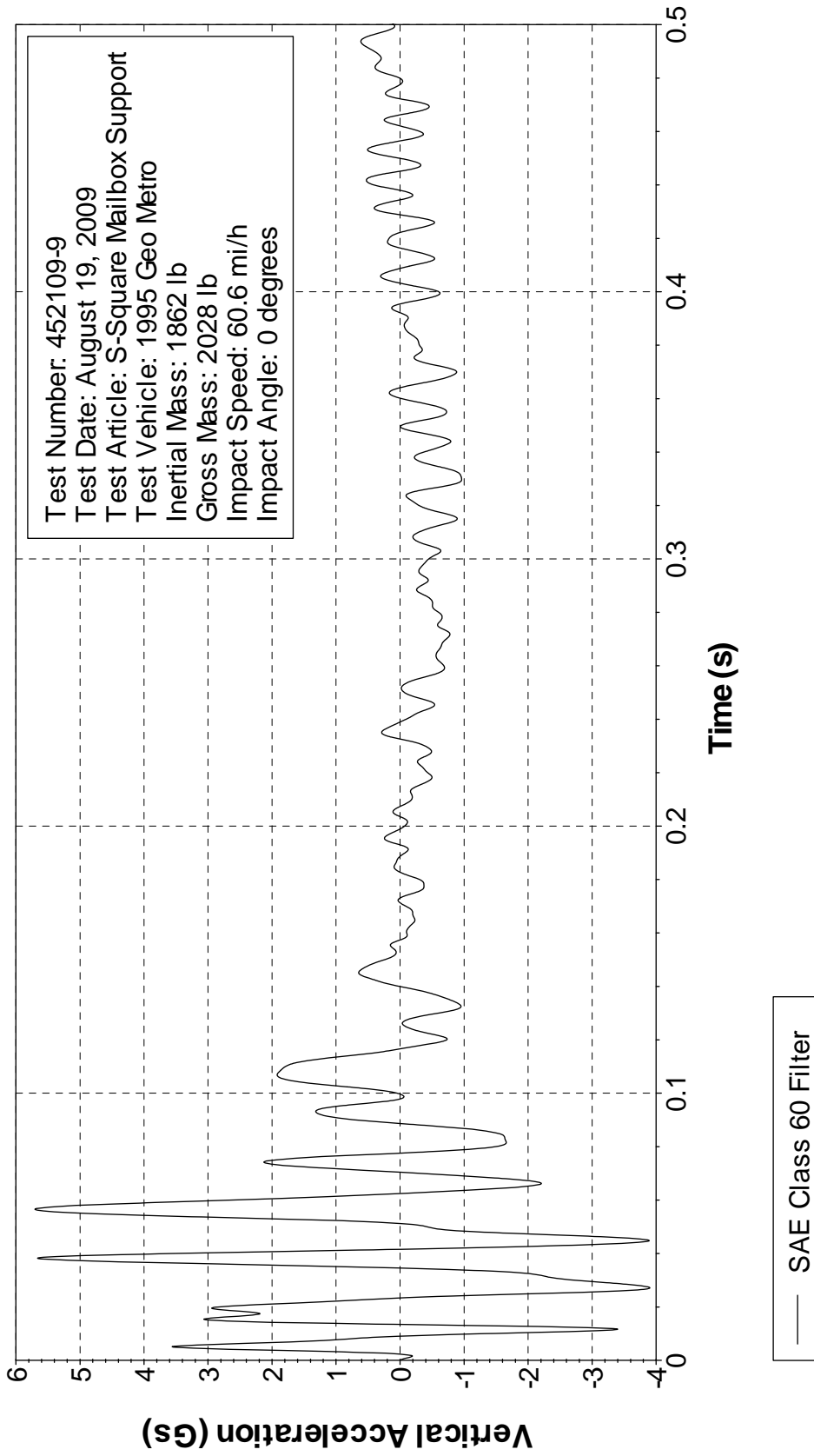

Figure 25. Vehicle Vertical Accelerometer Trace for Test No. 452109-9
(Accelerometer Located at Center of Gravity).

X Acceleration over Rear Axle

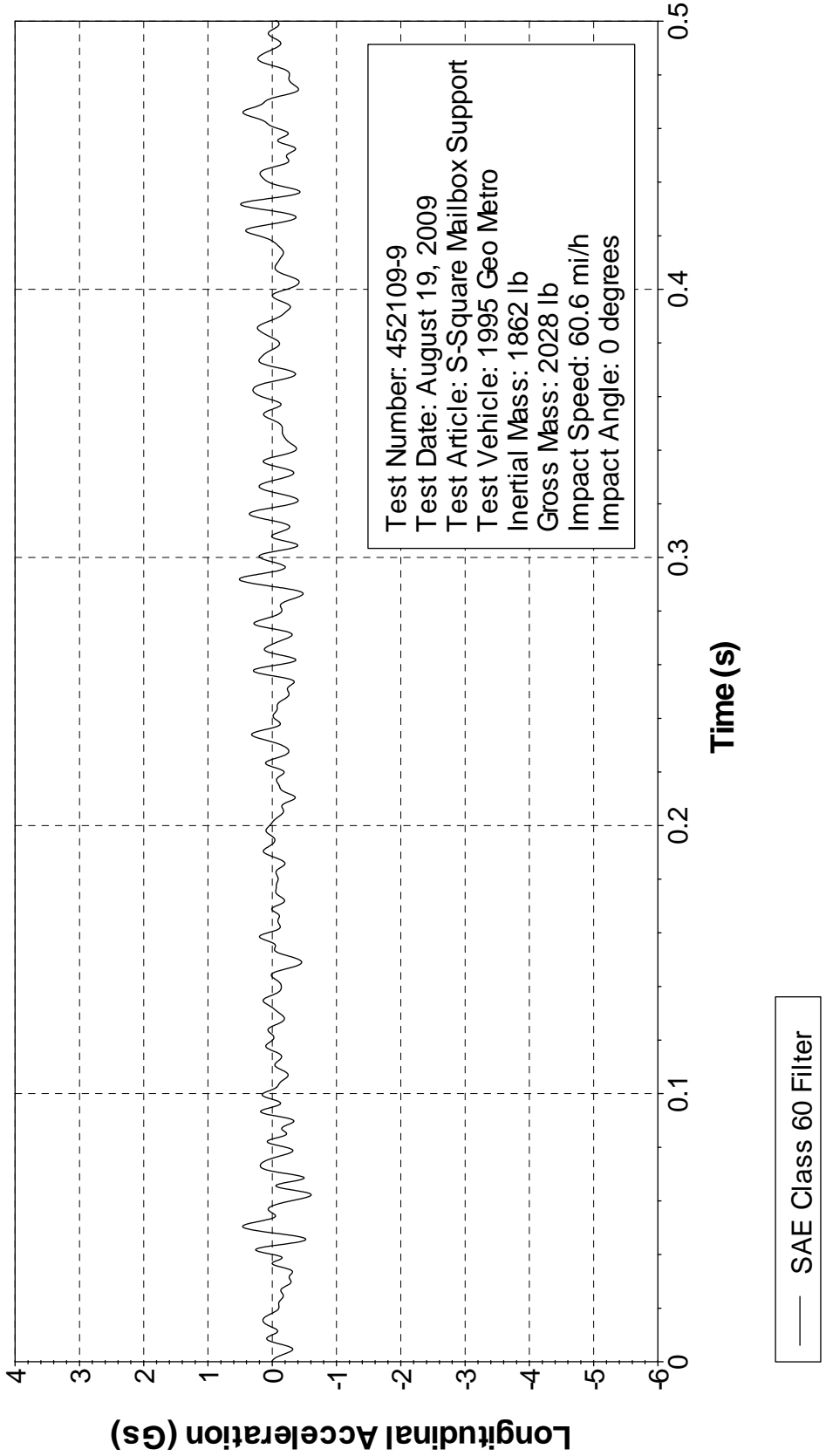

Figure 26. Vehicle Longitudinal Accelerometer Trace for Test No. 452109-9 (Accelerometer Located over Rear Axle).

Y Acceleration over Rear Axle

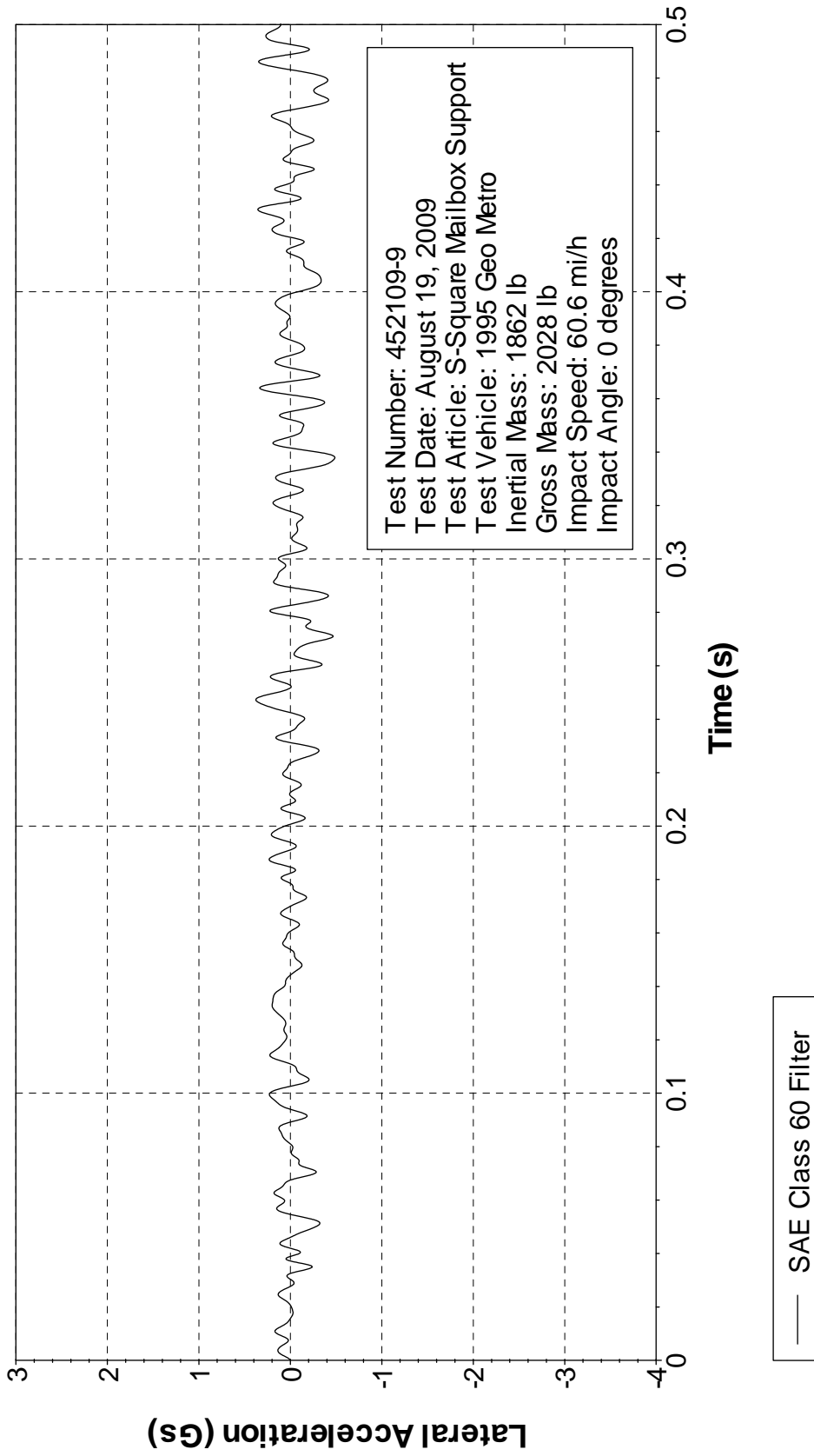

Figure 27. Vehicle Lateral Accelerometer Trace for Test No. 452109-9
(Accelerometer Located over Rear Axle).

Z Acceleration over Rear Axle

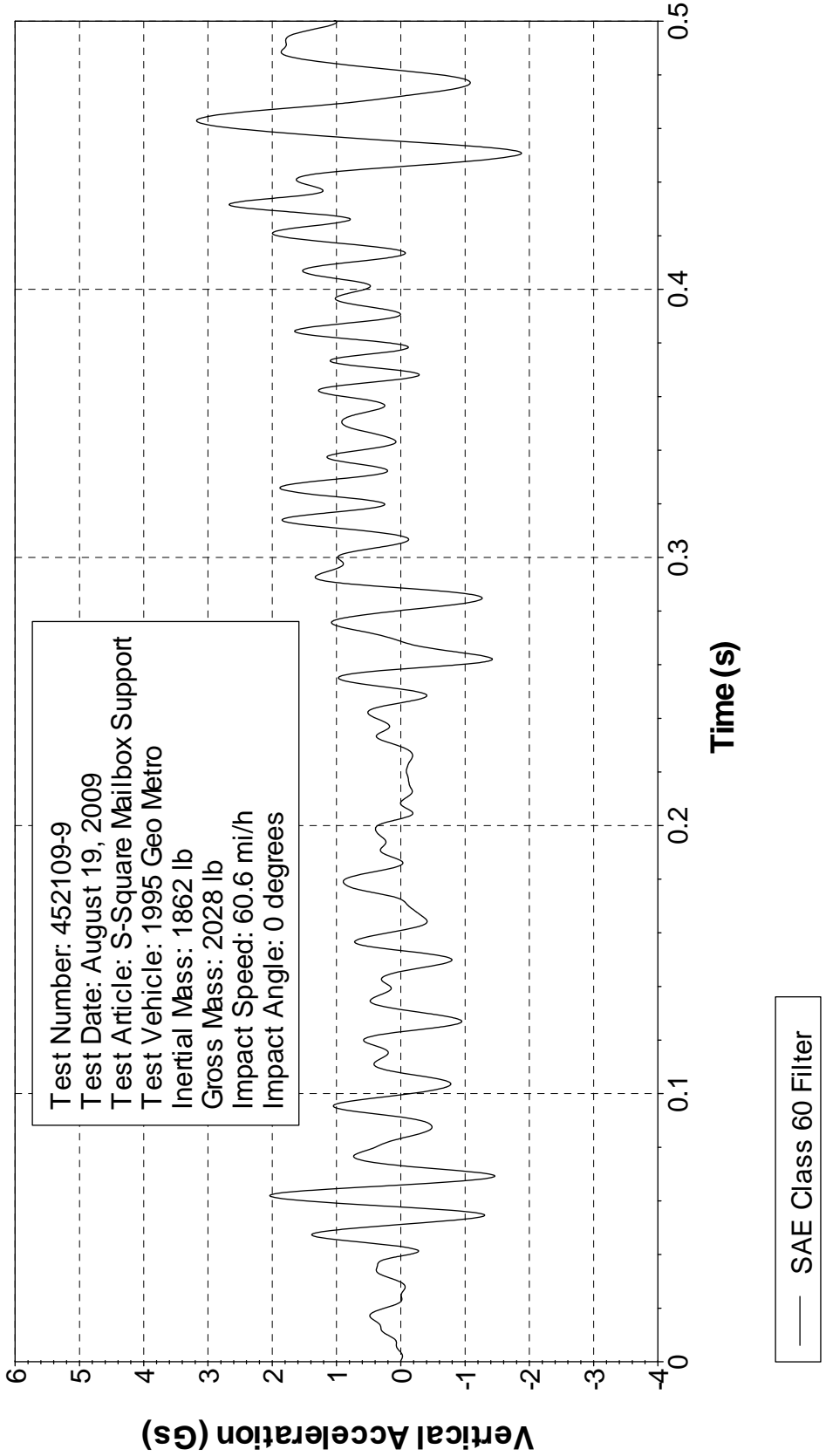

Figure 28. Vehicle Vertical Accelerometer Trace for Test No. 452109-9 (Accelerometer Located over Rear Axle).

Roll, Pitch, and Yaw Angles

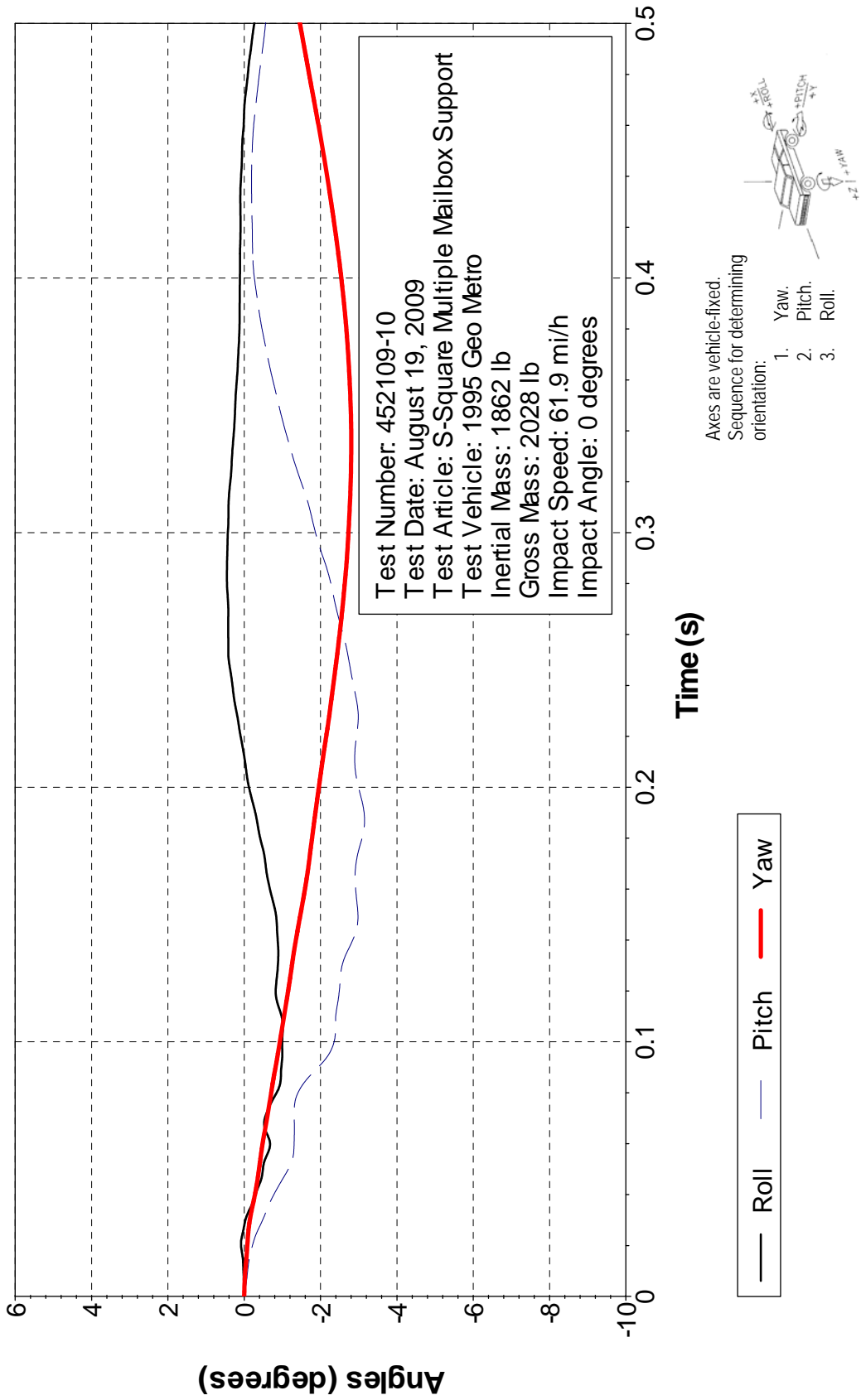

Figure 29. Vehicle Angular Displacements for Test 452109-10.

X Acceleration at CG

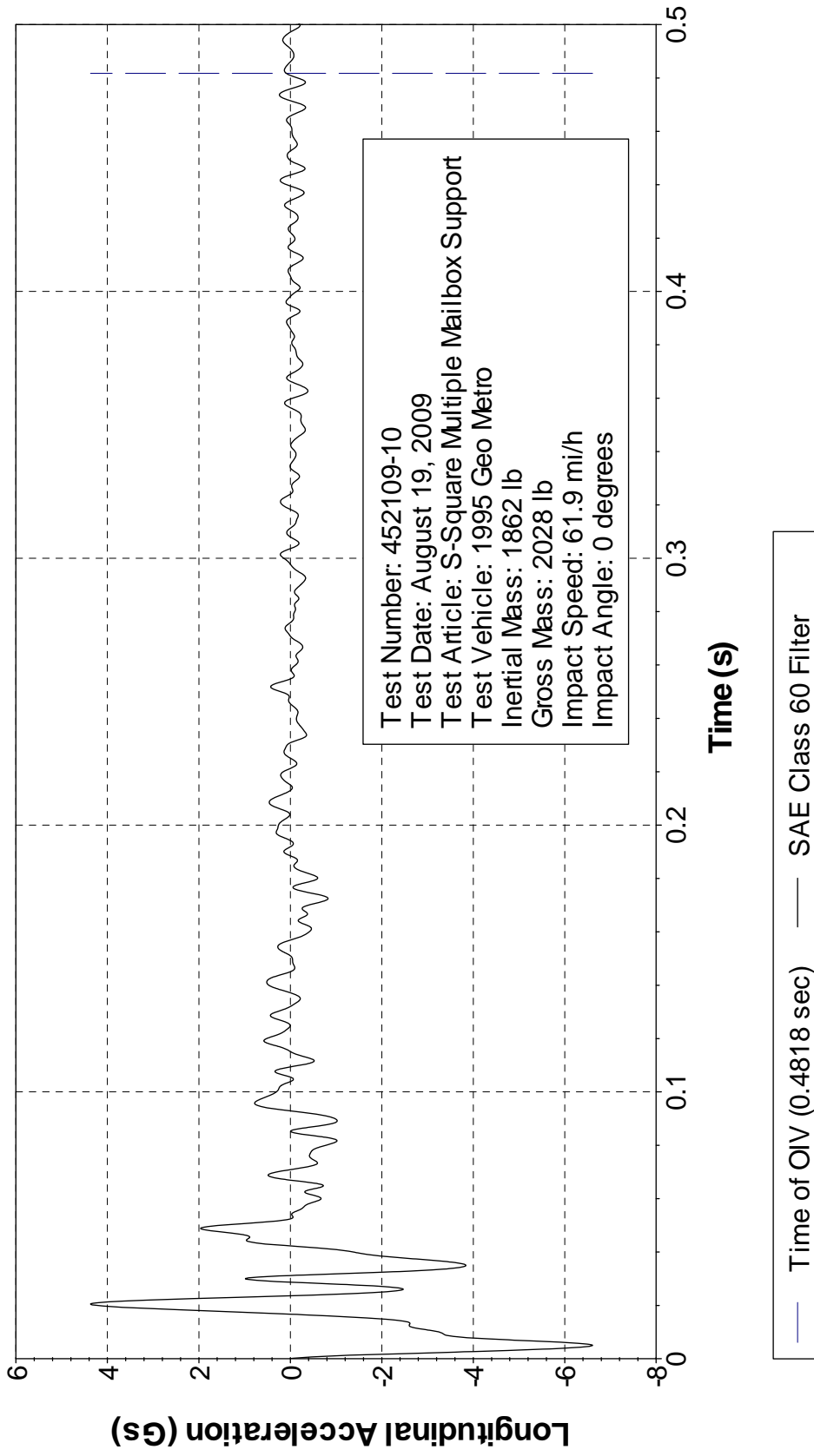

Figure 30. Vehicle Longitudinal Accelerometer Trace for Test 452109-10 (Accelerometer Located at Center of Gravity).

Y Acceleration at CG

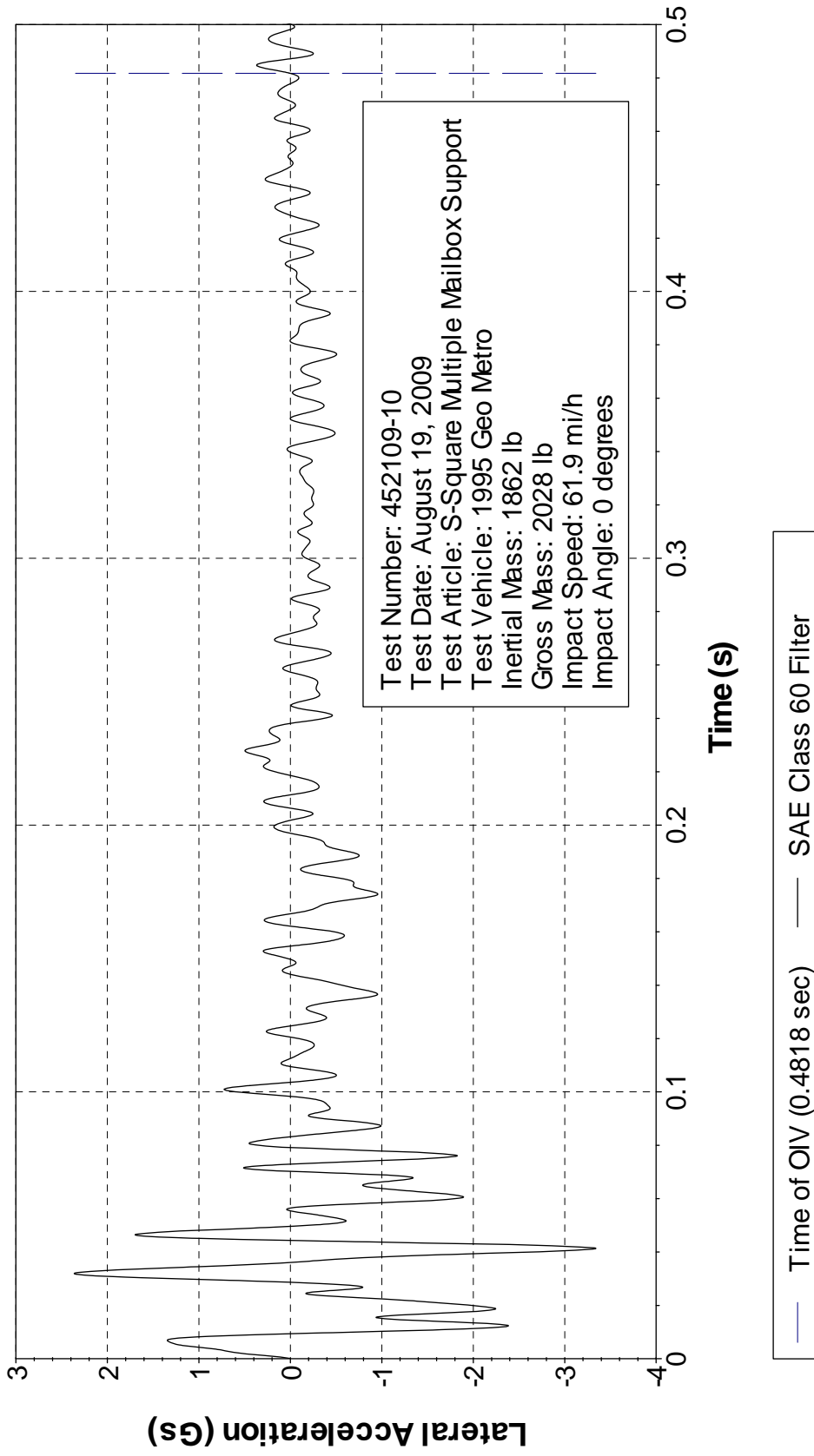

Figure 31. Vehicle Lateral Accelerometer Trace for Test 452109-10 (Accelerometer Located at Center of Gravity).

Z Acceleration at CG

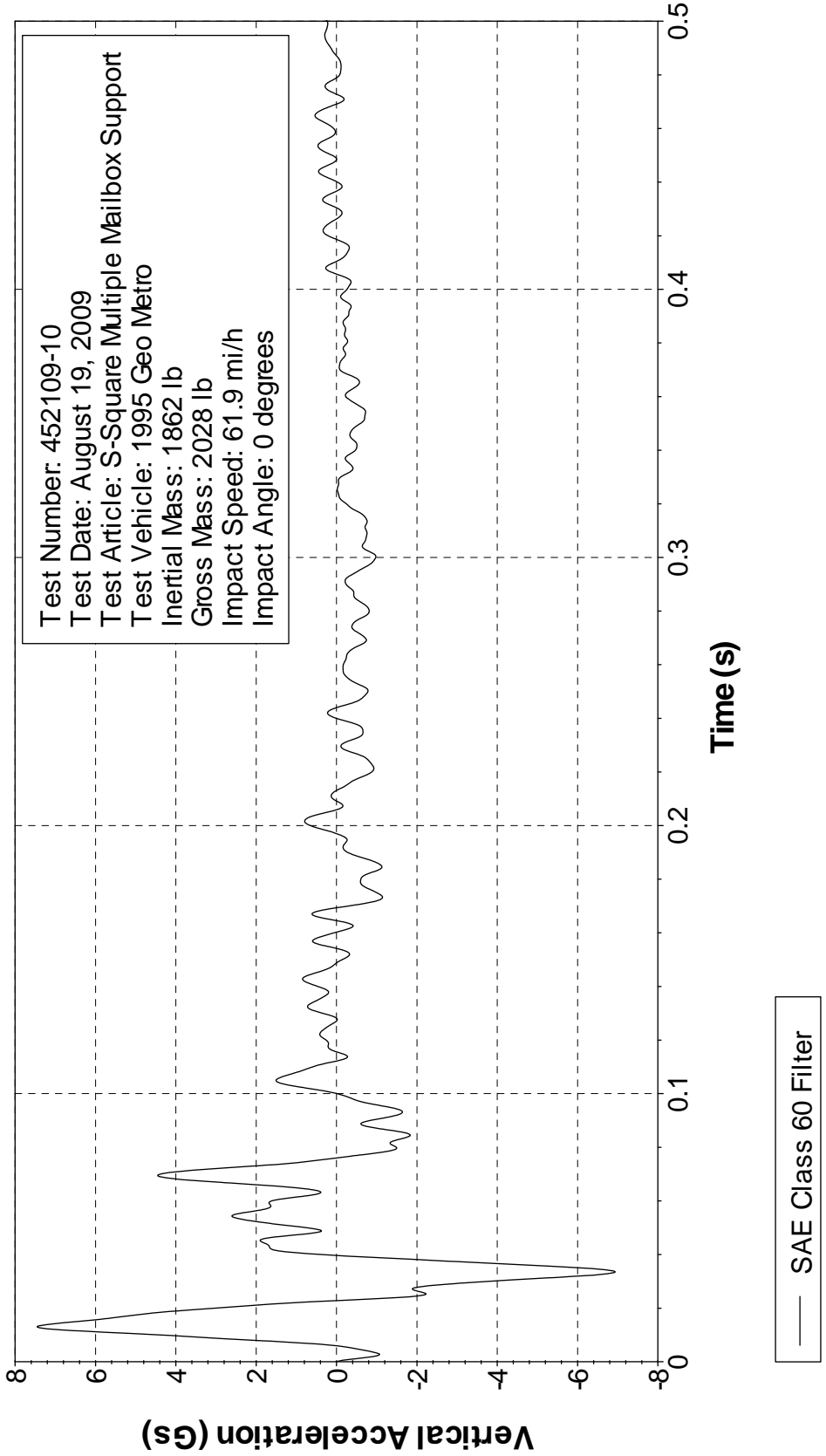

Figure 32. Vehicle Vertical Accelerometer Trace for Test 452109-10 (Accelerometer Located at Center of Gravity).

X Acceleration over Rear Axle

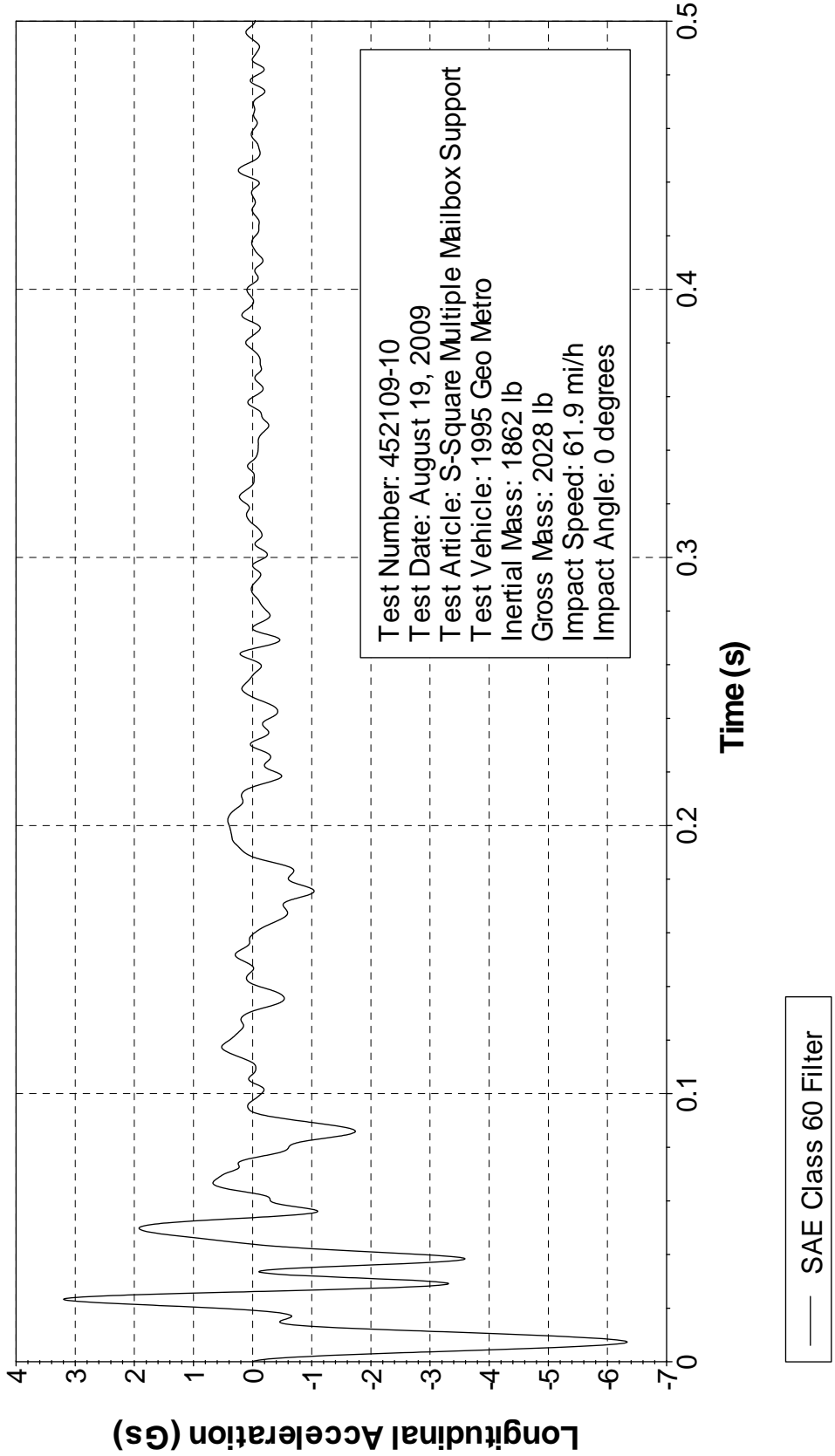

Figure 33. Vehicle Longitudinal Accelerometer Trace for Test 452109-10 (Accelerometer Located over Rear Axle).

Y Acceleration over Rear Axle

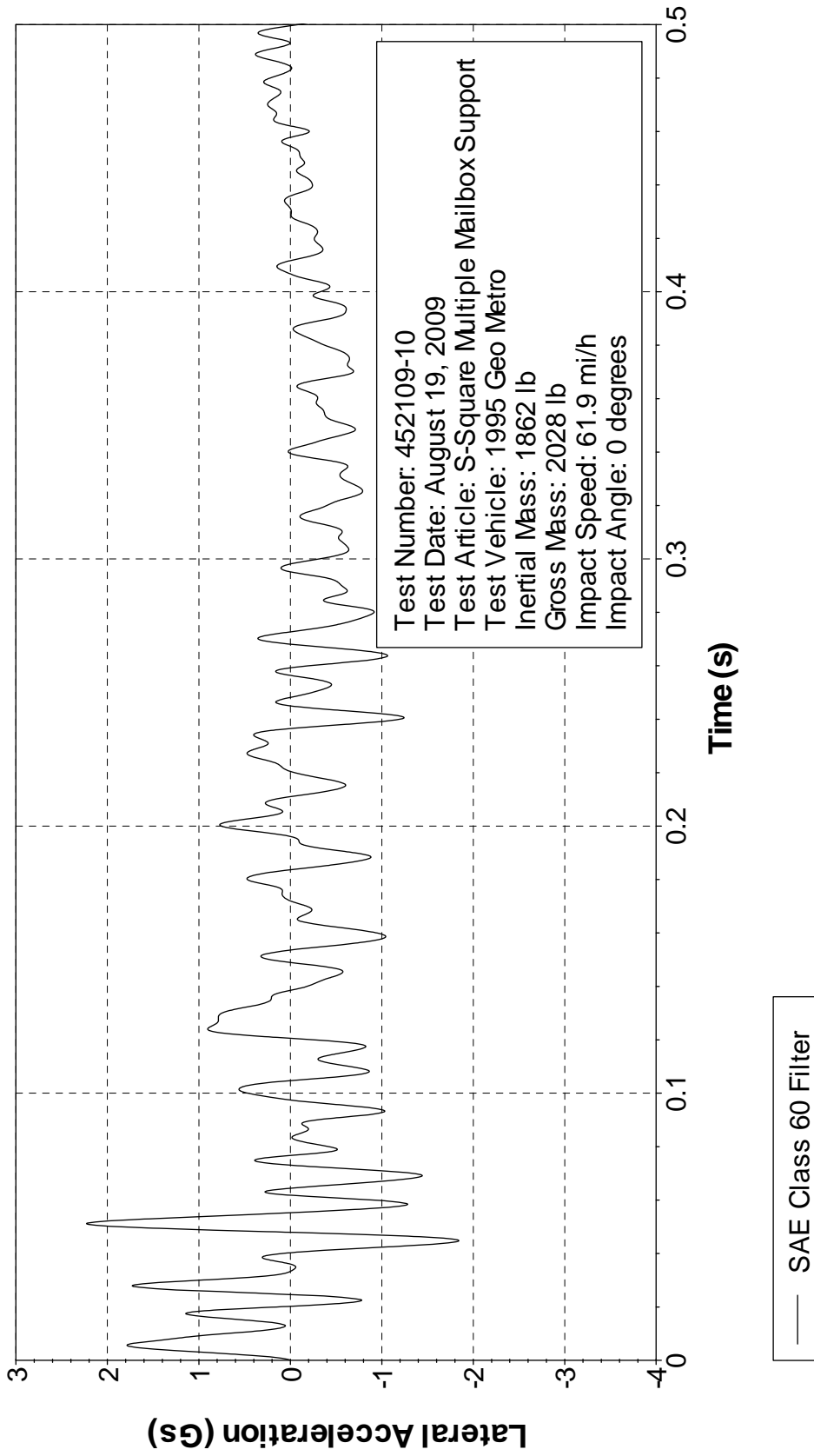

Figure 34. Vehicle Lateral Accelerometer Trace for Test 452109-10
(Accelerometer Located over Rear Axle).

Z Acceleration over Rear Axle

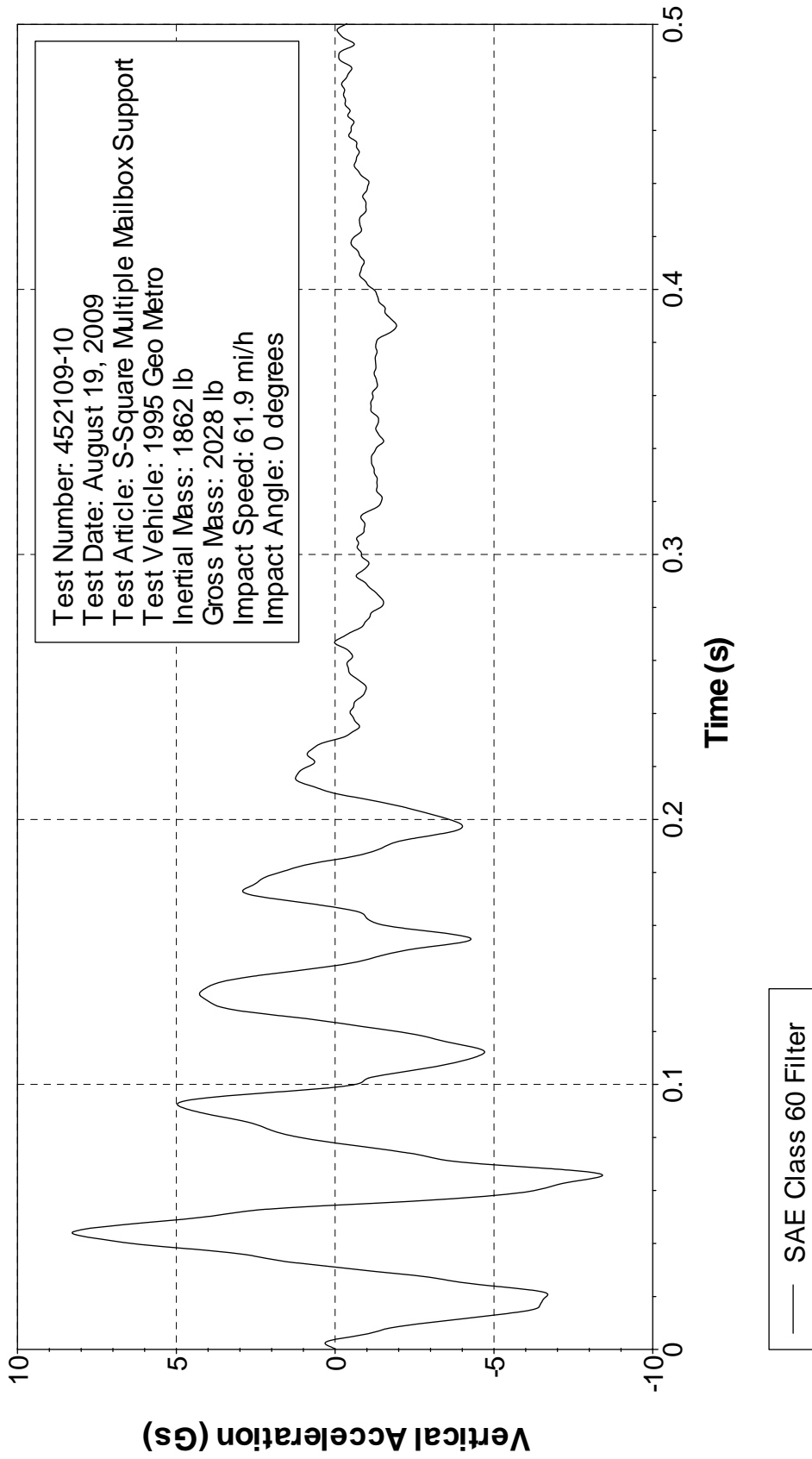

Figure 35. Vehicle Vertical Accelerometer Trace for Test 452109-10
(Accelerometer Located over Rear Axle).