

GUIDELINES
for
ANALYSIS and ABATEMENT
of
HIGHWAY
TRAFFIC
NOISE

June 1996

For Loan Only:
CTR Library

(Change 1, July 1997)

CHANGE LOG

Change #	Date	Summary of Change(s)	Page(s) *
1	July 1997	A. The definition of "substantially exceeds" is changed from "10 dBA or more" to "more than 10 dBA".	9, 19, 28, 29, 30, and 46
		B. The following "NOTE" is added: "Document all noise levels in whole numbers."	48

* Changes are printed in *bold italics* and are marked by a vertical line █ in the right margin. The change number and date are printed at the top of each page.

TABLE OF CONTENTS

I. INTRODUCTION 1

 A. Purpose 1

 B. References 1

 C. Applicability 1

 D. Scope 2

 E. Compliance 2

 F. Responsibilities 2

 G. Background 4

II. EXPLANATION of TERMS and LIST of ABBREVIATIONS 5

 A. Terms 5

 B. Abbreviations 10

III. FUNDAMENTALS of SOUND and TRAFFIC NOISE 11

 A. Sound 11

 1. Decibel 11

 2. A-weighted Levels 12

 3. Equivalent Sound Level (L_{eq}) 12

 4. Sources 13

 5. Loudness 14

 B. Noise 14

 C. Sound/Noise Levels 14

IV. TRAFFIC NOISE ANALYSIS 17

 A. Planning 17

 B. Requirements 17

 C. Objectives 17

 D. Documentation 17

V. TRAFFIC NOISE ANALYSIS PROCESS 19

 A. Determine Need for a Traffic Noise Analysis 20

 B. Type I Highway Projects 20

 C. Analysis Not Required 21

 D. Collect Data 22

 E. Measure/Model Noise Levels 25

 F. Determine Impact 28

 G. Abatement Not Required 30

 H. Consider Abatement Measures 30

 1. Traffic Management 30

 2. Alteration of Alignment 31

 3. Acquisition of Buffer Zone 31

 4. Insulation of Public Buildings 32

 5. Construction of Noise Barriers 32

 I. Evaluate Abatement Measures 35

 1. Feasible 35

 2. Reasonable 35

 3. Abatement Proposal 37

 J. Additional Topics 38

 1. Construction Noise 38

 2. Information for Local Officials 38

 3. Project Reevaluation 39

VI. PUBLIC INVOLVEMENT 41

 A. Public Perception 41

 B. Public Notification 41

 C. Public Approval 42

 D. Date of Public Knowledge 42

VII. DOCUMENTATION of TRAFFIC NOISE ANALYSES 43

 A. Traffic Noise Analysis Not Required 44

 B. Traffic Noise Analysis Required 44

 C. Statement of Compliance 44

 D. Sound/Noise Fundamentals 44

E. Noise Analysis Process 45

F. Project Description 47

G. Low Volume Highways 47

H. Undeveloped Land 47

I. Noise Levels 48

J. No Noise Impact 48

K. Noise Impact 48

L. Abatement Measures 48

M. No Abatement Measures are Feasible and Reasonable 49

N. Abatement Proposal 50

O. Construction Noise 50

P. Local Officials' Statement 51

Q. Noise Impact Contours 51

R. Project Reevaluation. 52

LIST of TABLES

1. DECIBEL ADDITION 11

2. CAUSE-and-EFFECT RELATIONSHIPS 13

3. SOUND LEVEL CHANGE vs LOUDNESS 14

4. COMMON SOUND/NOISE LEVELS 15

5. INTERIOR NOISE REDUCTION FACTORS 27

6. FHWA NOISE ABATEMENT CRITERIA 29

I. INTRODUCTION

These guidelines have been approved by the Federal Highway Administration (FHWA).

A. Purpose

1. The purpose of this document is to provide basic guidelines for performing traffic noise analyses for Texas Department of Transportation (TxDOT) highway projects, and includes a discussion of the fundamentals of sound and traffic noise, the traffic noise analysis process and associated documentation.
2. These guidelines supersede all previous TxDOT Noise Guidelines and associated correspondence.

B. References

1. Title 23, Code of Federal Regulations, Part 772 (23 CFR 772), "Procedures for Abatement of Highway Traffic Noise and Construction Noise", August 1982.
2. FHWA "Highway Traffic Noise Analysis and Abatement Policy and Guidance", June 1995.
3. Title 43, Texas Administrative Code, Chapter 2, "Environmental Policy", March 1995.

C. Applicability: these guidelines apply to all federal, federal-aid and state funded Type I highway projects.

1. Type I Project: a proposed highway project for the construction of a highway on a new location or the physical alteration of an existing highway that substantially changes either the horizontal or vertical alignment, or increases the number of through-traffic lanes.
2. Type II Project: a proposed highway project for noise abatement on an existing highway (sometimes referred to as a "retrofit" project).
 - a. The November 1995 National Highway System (NHS) Bill restricts federal participation in Type II barriers to those that: 1) were approved before the date of enactment of the NHS Bill, or 2) are proposed along lands that were developed or were under substantial construction before approval of the acquisition of the rights of way for, or construction

of, an existing highway.

- b. The development and implementation of Type II projects are not mandatory requirements of federal law or regulation.
- c. TxDOT does not have a Type II Noise Abatement Program.

D. Scope

- 1. These guidelines apply to typical TxDOT highway projects. They cannot and do not cover every conceivable situation or contingency. They are designed to allow sufficient flexibility to permit an effective analysis of unique or atypical highway projects. Contact TxDOT's Environmental Affairs Division (ENV) for any additional guidance/assistance, as necessary.
- 2. A detailed discussion of the FHWA approved traffic noise modeling software is beyond the scope of this document. A comprehensive user's manual will be provided separately.
- 3. Although a traffic noise analysis may include preliminary dimensions and locations of noise barriers, a detailed discussion of noise barrier design specifications and construction techniques is also beyond the scope of this document. A comprehensive noise barrier design manual will be provided separately.

E. Compliance

- 1. Compliance with 23 CFR 772 is a prerequisite for granting federal-aid highway funds for construction or reconstruction of a highway.
- 2. These guidelines were developed in accordance with 23 CFR 772 and FHWA Policy and Guidance for Highway Traffic Noise Analysis and Abatement; therefore, compliance with these guidelines is also a prerequisite for granting federal-aid highway funds for construction or reconstruction of a highway.

F. Responsibilities

- 1. TxDOT/ Environmental Affairs Division (ENV):
 - a. develop and publish TxDOT Guidelines for Analysis and Abatement of Highway Traffic

- Noise, and provide changes/updates, as necessary.
- b. review, evaluate and approve traffic noise analyses and any associated noise abatement proposals.
 - c. submit noise abatement proposals to FHWA for approval.
 - d. conduct training in traffic noise analysis and associated computer modeling.
 - e. provide guidance and assistance to TxDOT districts, as necessary.
 - f. maintain a comprehensive statewide noise barrier database and provide periodic updates to FHWA, as required.
 - g. publish and maintain an informative noise barrier brochure.
 - h. develop and publish a comprehensive user's manual for the FHWA approved traffic noise modeling software.
2. TxDOT district/area offices:
- a. perform traffic noise analyses according to the latest TxDOT Guidelines for Analysis and Abatement of Highway Traffic Noise.
 - b. submit traffic noise analyses/noise abatement proposals to TxDOT/ENV for approval.
 - c. review and evaluate all traffic noise analyses performed by consultants before submitting to TxDOT/ENV.
 - d. ensure all personnel responsible for conducting traffic noise analyses receive initial and recurring training in the proper use and application of these guidelines, traffic noise modeling software and sound meters.
 - e. conduct noise workshops to inform the public about a noise abatement proposal and/or to solicit public opinion regarding a noise abatement proposal, as necessary.
 - f. maintain a comprehensive noise barrier database and provide periodic updates to

TxDOT/ENV, as required.

3. Consultants under contract to perform traffic noise analyses for TxDOT:
 - a. conduct traffic noise analyses according to the latest TxDOT Guidelines for Analysis and Abatement of Highway Traffic Noise.
 - b. obtain/use the latest FHWA approved traffic noise modeling software and associated training.

G. Background

1. The National Environmental Policy Act (NEPA) of 1969 provides broad authority and responsibility for evaluating and mitigating adverse environmental effects, including highway traffic noise. NEPA directs the federal government to use all practical means and measures to promote the general welfare and foster a healthy environment.
2. The federal legislation that specifically involves abatement of highway traffic noise is the Federal-Aid Highway Act of 1970. This law mandates FHWA to develop noise standards for mitigating highway traffic noise and requires promulgation of traffic noise-level criteria for various land use activities.
3. The FHWA regulations for highway traffic noise analysis and abatement during the planning and design of federally aided highway projects are contained in 23 CFR 772, "Procedures for Abatement of Highway Traffic Noise and Construction Noise", August 1982.
4. In June 1995, FHWA reissued existing guidance on highway traffic noise analyses in a consolidated document entitled "Highway Traffic Noise Analysis and Abatement Policy and Guidance."

II. EXPLANATION of TERMS and LIST of ABBREVIATIONS: (as they apply to highway traffic noise analyses)

A. Terms

- **23 CFR 772** (Title 23, Code of Federal Regulations, Part 772) “Procedures for Abatement of Highway Traffic Noise and Construction Noise”: FHWA regulations for highway traffic noise analysis and abatement during the planning and design of federally aided highway projects.
- **Abatement:** any positive action taken to reduce the impact of highway traffic noise.
- **Abatement Measures:** measures that must be considered in a traffic noise analysis when a highway project will result in a noise impact. These measures include:
 - Traffic management
 - Alteration of horizontal and vertical alignments
 - Acquisition of real property to serve as a buffer zone
 - Insulation of public use or nonprofit institutional structures
 - Construction of noise barriers
- **Absolute Criterion:** one of two criteria (see “Relative Criterion”) used to determine when a noise impact occurs. Under this criterion, a noise impact occurs when the predicted noise level approaches, equals or exceeds the FHWA Noise Abatement Criteria.
- **Activity Areas:** categories of land use adjacent to a highway project.
- **Alpha Factors:** adjustments to the sound propagation rate as a result of the attenuation of sound as it travels a specified distance. The level of attenuation (absorption) is dependent on the surface type and the distance from the source to the receiver. Soft or grass covered surfaces have a higher absorption rate than hard or paved surfaces. These adjustments are performed automatically by the traffic noise computer model.
- **Approach:** one (1) dBA below the FHWA Noise Abatement Criteria (see “Absolute Criterion”).
- **Attenuation:** reduction or lowering of the level of sound or noise.

- **Automobiles:** vehicles with two axles and four wheels designed primarily for transporting passengers and or cargo (includes light trucks). Generally, the gross weight is less than 4,500 kilograms.
- **Average Daily Traffic (ADT):** the average 24-hour traffic count (vehicles per day). Typically, the total amount of traffic during a stated period (normally one year) divided by the number of days in that period. The ADT is only used as the basis for determining the “Design Hourly Volume”(DHV). The DHV is used to model noise levels.
- **A-Weighting (dBA):** an adjustment in sound meters and traffic noise modeling software to ensure sound levels are measured/calculated in a manner that approximates the sounds that can be heard by the human ear. This is accomplished by suppressing the low and very high frequencies that cannot be heard by the human ear.
- **Benefitted Receiver:** a receiver is “benefitted” if an abatement measure reduces the noise level at the receiver by at least 5 dBA, regardless of whether or not the receiver was “impacted.” The total number of benefitted receivers is used to evaluate the cost effectiveness of an abatement measure (see “Reasonable”).
- **Categorical Exclusion (CE):** a project that involves actions that will result in no significant environmental impacts. Specifically, these actions will not induce significant impacts to planned growth or land use for the area; will not require the relocation of significant numbers of people; will not have a significant impact on any natural, cultural, recreational or historic resource; will not involve significant air, noise or water quality impacts; will not have significant impacts on traffic patterns; or will not otherwise, either individually or cumulatively, have any significant environmental impact.
- **Contour (noise):** the location of a specific noise level relative to the source - can either be presented in tabular or graphic form.
- **Cost Effectiveness:** see “Reasonable.”
- **Date of Public Knowledge:** the date of approval of the environmental document (CE, EA/FONSI or EIS) for a highway project - when federal and state governments are no longer responsible for providing noise abatement for new development adjacent to a proposed highway project.

- **Decibel (dB):** the basic unit for measuring sound pressure levels.
- **Design Hourly Volume (DHV):** the traffic count (vehicles per hour) determined by applying the “K-factor” to the “Average Daily Traffic.” The DHV is used to model noise levels.
- **Design Year:** the year used as a basis for calculating predicted (future) noise levels - normally 20 years from the current (existing) year.
- **Diffraction:** the bending of sound waves around an obstacle (over or around a noise barrier) that results in a corresponding “attenuation” of the sound level.
- **Environmental Assessment (EA):** document prepared for a project when the significance of environmental impacts is not clearly exhibited. The assessment may result in either a Finding of No Significant Impact or an Environmental Impact Statement.
- **Environmental Impact Statement (EIS):** document prepared for a project when significant impacts are evident, or identified in an Environmental Assessment.
- **Existing Noise Level:** the level of traffic noise measured or modeled at a receiver for the current (existing) pre-construction (no-build) highway project.
- **Feasible:** one of two criteria (see “Reasonable”) used to evaluate a noise abatement measure. Generally, pertains to the ability of a noise abatement measure to provide a “substantial reduction” (at least 5 dBA) in noise levels, and deals primarily with engineering considerations.
- **Heavy Trucks:** vehicles with three or more axles. Generally, the gross weight is greater than 12,000 kilograms.
- **Impact:** when predicted traffic noise reaches a level that requires a consideration of noise abatement measures (see “Absolute Criterion” and “Relative Criterion”).
- **Insertion Loss:** the actual benefit (noise level reduction) derived from the construction of a noise barrier.
- **K-factor:** number applied to the “Average Daily Traffic” to determine the “Design Hourly Volume.” The K-factor is normally 10 percent (plus or minus one percent).

- **L_{eq}** (Equivalent Noise Level): the equivalent steady-state sound level that, in a given time period, contains the same acoustic energy as a time-varying sound level during the same period. **L_{eq} is used for all traffic noise analyses for TxDOT highway projects.**
- **L_{10}** : the sound level that is exceeded 10 percent of the time in the noisiest hour of the day. **L_{10} is no longer used in TxDOT traffic noise analyses.** (see “ L_{eq} ”).
- **Loudness**: the subjective/perceived assessment of the intensity of sound.
- **Medium Trucks**: vehicles with two axles and six wheels. Generally, the gross weight is greater than 4,500 but less than 12,000 kilograms.
- **Mitigation**: alternative to the preferred term “abatement.”
- **Noise Abatement Criteria (NAC)**: absolute sound levels, provided by FHWA, that are used to determine when a noise impact occurs (see “Absolute Criterion”). They are not used as a design goal for a noise abatement measure.
- **Noise Barrier**: typically, a solid wall-like structure located between the noise source (traffic) and the impacted receiver (human activity area) to reduce noise levels. The construction of a noise barrier is one of the abatement measures that must be considered when a traffic noise analysis indicates that a highway project will result in a noise impact.
- **Noise Wall**: alternative to the preferred term “noise barrier.”
- **Predicted Noise Level**: the level of traffic noise modeled at a receiver in the “design year” of a proposed highway project.
- **Reasonable**: one of two criteria (see “Feasible”) used to evaluate a noise abatement measure. Generally, pertains to the cost effectiveness (will not exceed \$25,000 for each benefitted receiver) of a noise abatement measure and the views/desires of the public.
- **Receiver**: the specific location of an outdoor area where frequent human activity occurs that might be impacted by highway traffic noise and may benefit from reduced noise levels. If no outdoor location can be identified, an interior location may be used.
- **Receptor**: alternative to the preferred term “receiver.”

- **Relative Criterion:** one of two criteria (see “Absolute Criterion”) used to determine when a noise impact occurs. Under this criterion, a noise impact occurs when the predicted noise level “substantially exceeds” (*more than 10 dBA*) the existing level even if it does not approach, equal or exceed the FHWA Noise Abatement Criteria.
- **Significant:** do not use this term in a traffic noise analysis - to avoid any conflict or confusion with “Finding Of No Significant Impact” for Environmental Assessments.
- **Sound:** mechanical energy produced by the movement of waves of compressed air radiating spherically from a source that can be sensed by the human ear.
- **Sound Meter:** a device used to measure existing (actual) sound levels. Also referred to as a sound level dosimeter or analyzer.
- **Soundwall:** alternative to the preferred term “noise barrier.”
- **STAMINA 2.0/OPTIMA:** current FHWA approved traffic noise/barrier modeling software (see “Traffic Noise Model”).
- **Substantially Exceeds (Substantial Increase):** when the predicted noise level exceeds the existing level by *more than 10 dBA* (see “Relative Criterion”).
- **Substantial Reduction:** noise level reduction of at least 5 dBA at impacted receivers (see “Feasible”).
- **Through-Traffic Lane:** a continuous main lane (including high occupancy vehicle lane) or frontage road.
- **Traffic Noise Model:** new FHWA traffic noise modeling software being developed as a replacement for STAMINA 2.0/OPTIMA.
- **Type I Project:** a proposed highway project for the construction of a highway on a new location or the physical alteration of an existing highway that substantially changes either the horizontal or vertical alignment, or increases the number of through-traffic lanes.
- **Type II Project:** a proposed highway project for noise abatement on an existing highway (retrofit project) - not a mandatory requirement of federal law or regulation.

B. Abbreviations

- **23 CFR 772:** Title 23, Code of Federal Regulations, Part 772
- **ADT:** Average Daily Traffic
- **dB:** Decibel
- **dBA:** A-weighted decibel
- **DHV:** Design Hourly Volume
- **ENV:** Environmental Affairs Division of the Texas Department of Transportation
- **EPA:** U. S. Environmental Protection Agency
- **FHWA:** Federal Highway Administration
- **L_{eq}:** Equivalent Noise Level
- **NEPA:** National Environmental Policy Act
- **TNM:** Traffic Noise Model
- **TxDOT:** Texas Department of Transportation

III. FUNDAMENTALS of SOUND and TRAFFIC NOISE

A. Sound: Sound can be defined as mechanical energy produced by the movement of waves of compressed air radiating spherically from a source that can be sensed by the human ear. Or, simply stated, sound is what we hear. Although sounds are perceived differently from one person to another, they can be precisely measured.

1. Decibel

- a. Sound spans a large dynamic range and any associated calculations in units of pressure involve cumbersome astronomical numbers. Therefore, in order to simplify the process, the strength of sound is commonly measured on a relative scale of sound pressure levels expressed in decibels or "dB."
- b. Because the decibel is a simple representation of a much larger value, it is considered as a logarithmic (based on powers of 10) rather than a linear function. Consequently, sound levels cannot be added by ordinary arithmetic means. Representative examples of decibel addition are shown in **Table 1**. From this table it can be seen that doubling a noise source produces only a 3 dB increase in the sound pressure level.

Table 1: DECIBEL ADDITION*			
Difference Between Two Sources	For Example	Add to the Higher Level	Resultant Sound Level**
0 dB	60 and 60 dB	3 dB	63 dB
1 dB	60 and 61 dB		64 dB
2 dB	60 and 62 dB	2 dB	64 dB
3 dB	60 and 63 dB		65 dB
4-9 dB	60 and 65 dB	1 dB	66 dB
10 dB or more	60 and 70 dB	0 dB	70 dB

* This table only represents approximations of the logarithmic function of decibel addition.
 ** Accurate within 1 dB

2. A-weighted Levels

- a. Sound is composed of a wide range of frequencies measured in Hertz (Hz). A healthy human adult responds to sounds ranging from 20-20,000 Hz or, roughly, from the lowest note of a pipe organ to the highest note of a violin.
- b. Traffic sounds normally range from 100-4,000 Hz. Because the human ear does not hear all frequencies, an adjustment is made to the high and low frequencies to approximate the average human response to traffic sounds. These adjusted sound levels are referred to as "A-weighted levels" and expressed as "dBA."

3. Equivalent Sound Level (L_{eq})

- a. Highway traffic sounds are never constant. Sound levels vary in frequency and their intensity fluctuates over time. Therefore, an equivalent sound level, expressed as " L_{eq} " is used to represent a single number to describe varying traffic sound levels.
- b. More specifically, L_{eq} is the equivalent steady-state sound level that, in a given time period, contains the same acoustic energy as a time-varying sound level during the same period (see diagram below). L_{eq} is used for all traffic noise analyses of TxDOT highway projects.

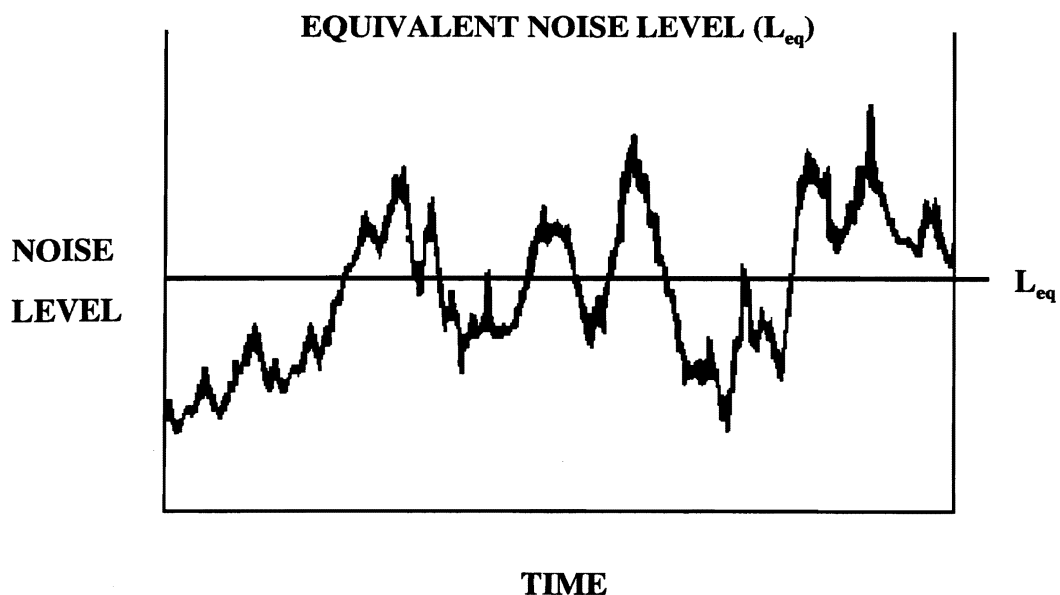

4. **Sources:** The primary sources of highway traffic sounds are the tires, engine and exhaust of the various types of vehicles present.
- a. The level of traffic sounds generally depends on the overall number, type and speed of the vehicles (especially trucks) and the distance between the source (traffic) and the receiver (human). Any condition (such as a steep incline) that causes heavy laboring of a vehicle's engine will also affect the overall level of traffic sounds.
 - b. There are additional, more complicated factors that affect the level of traffic sounds, including: elevated or depressed highways/terrain, surface absorption, dense vegetation and shielding from buildings, fences or walls.
 - c. Some of the more common factors that influence the level of traffic sounds at a receiver are outlined in **Table 2**. These cause-and-effect relationships can be used throughout the traffic noise analysis to double-check preliminary and final calculations; however, they are not to be used in the place of actual sound level measurements and/or modeling.

Table 2: CAUSE-and-EFFECT RELATIONSHIPS (dBA)*		
Change**	Increase	Decrease
Traffic count doubled	3	
Speed limit lowered by 5 mph		1
Depressed highway		3-5
Elevated highway		3-5***
Distance doubled over pavement		3
Distance doubled over grass		4.5
Effects are Cumulative		
Speed limit lowered by 5 mph + Distance doubled over grass		5.5
<p>* These figures are approximations and are not to be used to calculate sound levels.</p> <p>** Assumes that all other factors remain constant.</p> <p>*** For nearby receivers - may actually increase slightly at more distant receivers because of possible reductions in shielding and/or surface absorption.</p>		

5. **Loudness:** The term “loudness” is used to describe the manner in which people perceive the intensity of sound.
- The loudness level is based on a subjective comparison of different sounds under controlled laboratory conditions.
 - The human ear is a far better detector of relative (comparative) differences in sound levels than absolute levels. **Table 3** depicts the relationship between changes in sound levels and the perceived change in loudness.

Table 3: SOUND LEVEL CHANGE vs LOUDNESS	
Sound Level Change	Relative Loudness
1 dBA	No perceptible change
3 dBA	Barely perceptible change
5 dBA	Readily perceptible change
10 dBA increase	Perceived as twice as loud

B. Noise: Noise is commonly defined as unwanted sound. However, as indicated in the above discussion on loudness, the determination of “unwanted” is very subjective and can vary substantially from one person to another. Therefore, the Federal Highway Administration (FHWA) has established absolute and relative criteria to more objectively determine when traffic sounds reach levels that result in impacts for humans.

- Absolute Criterion:** Under this criterion, a noise impact occurs when the predicted noise level approaches, equals or exceeds the FHWA Noise Abatement Criteria (NAC) (page 29).
- Relative Criterion:** Under this criterion, a noise impact occurs when the predicted noise level “substantially exceeds” the existing level even if it does not approach, equal or exceed the NAC (page 29).

C. Sound/Noise Levels: Representative sound pressure levels (decibels) for a variety of common outdoor and indoor areas/activities are depicted in **Table 4**.

Table 4: COMMON SOUND/NOISE LEVELS		
Outdoor	dBA	Indoor
	110	Rock band at 5 meters
Jet flyover at 300 meters		
Pneumatic hammer	100	Subway train
Gas lawn mower at 1 meter		
	90	Food blender at 1 meter
Downtown (large city)	80	Garbage disposal at 1 meter
		Shouting at 1 meter
Lawn mower at 30 meters	70	Vacuum cleaner at 3 meters
Commercial area		Normal speech at 1 meter
Air conditioning unit	60	Clothes dryer at 1 meter
Babbling brook		Large business office
Quiet urban (daytime)	50	Dishwasher (next room)
Quiet urban (nighttime)	40	Library
	30	
	20	
	10	
		Threshold of hearing
	0	

THIS PAGE
INTENTIONALLY LEFT BLANK

IV. TRAFFIC NOISE ANALYSIS

A. Planning: Comprehensive planning and coordination should be accomplished as early as possible in the project development process to ensure that comparative analyses of all transportation alternatives include serious consideration for minimizing or avoiding traffic noise impacts. This could reduce or eliminate the need for costly abatement later in the design process.

B. Requirements: A traffic noise analysis is required for all federal, federal-aid and state funded Type I highway projects. Type I highway projects, as defined in 23 CFR 772, include:

1. Construction of a highway on a new location.
2. The physical alteration of an existing highway that substantially changes either the horizontal or vertical alignment.
3. An increase in the number of through-traffic lanes.

C. Objectives: The major objectives of a traffic noise analysis are to:

1. Identify areas where possible noise impacts may occur for each project alternative.
2. Consider and evaluate abatement measures to mitigate these impacts.
3. Propose implementation of feasible and reasonable abatement measures.
4. Communicate the results to the public and local officials.

D. Documentation: A traffic noise analysis is designed to provide comprehensive information to the public and local government officials/decision-makers.

1. **Public:** The analysis should clearly, concisely and accurately provide individuals affected by a highway project with a basic understanding of traffic noise fundamentals, regulatory requirements, the traffic noise analysis process, and any associated impacts/abatement.
2. **Local Government Officials:** The traffic noise analysis should provide government decision-makers with an important element of the overall environmental data needed for an informed selection of a project alternative and for the development of compatible land use plans.

**THIS PAGE
INTENTIONALLY LEFT BLANK**

V. TRAFFIC NOISE ANALYSIS PROCESS

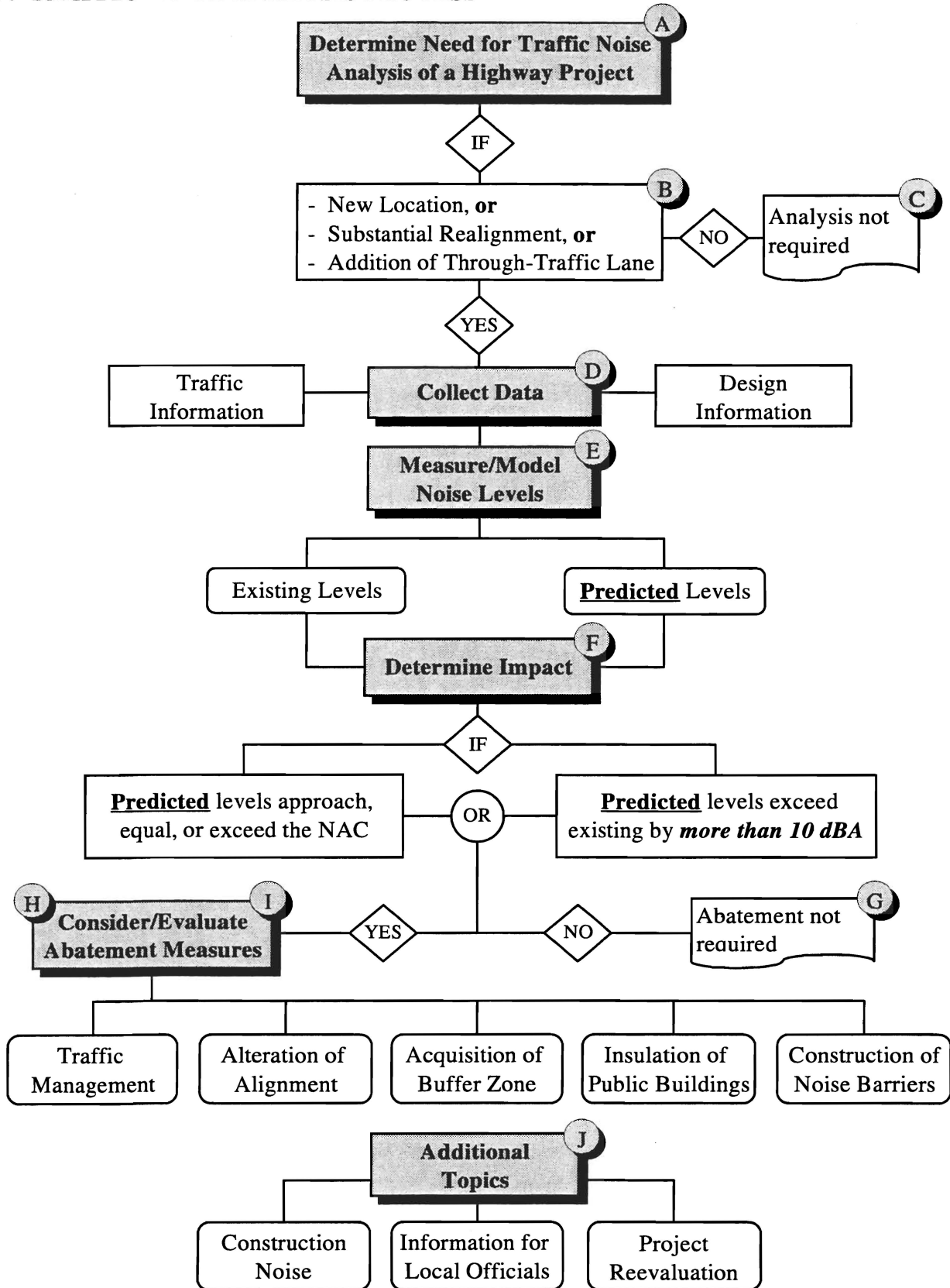

A. Determine Need for a Traffic Noise Analysis of a Highway Project

1. The need for a traffic noise analysis is often determined by the type and level of documentation used in the environmental review of a highway project. The level of documentation generally depends on the scope, size and alignment of a highway project, and anticipated environmental impacts, as outlined below:
 - a. Categorical Exclusion (CE): a minor action/project that does not individually or cumulatively have a significant environmental impact.
 - b. Environmental Assessment (EA): an action/project for which the significance of the environmental impact is not clearly established.
 - c. Environmental Impact Statement (EIS): a major action/project often involving several alternatives that will significantly affect the environment.
2. Generally, all EISs and EAs require a traffic noise analysis, while most CEs do not. To avoid any confusion, traffic noise analyses should be conducted for all Type I highway projects, regardless of the level of documentation. When in doubt, contact TxDOT/ENV for assistance.

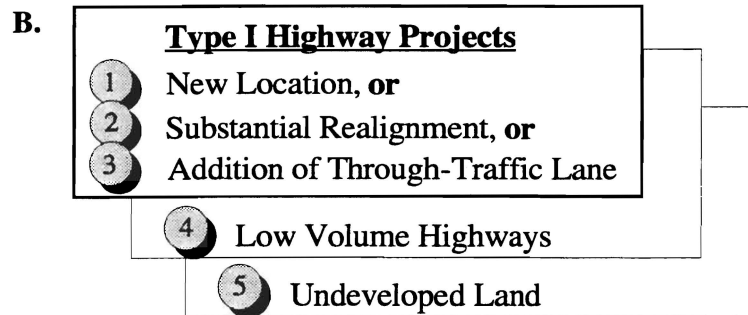

1. Construction of a highway on a **new location**: self-explanatory.
2. The physical alteration of an existing highway that **substantially changes either the horizontal or vertical alignment**:
 - a. Horizontal alignment: applies to highway improvement projects that move the horizontal

alignment of an existing roadway more than one through-traffic lane closer to a receiver.

b. Vertical alignment

- (1) Applies to highway improvement projects that either depress or elevate an existing roadway by one or more levels (overpass/underpass).
- (2) As previously discussed under "Fundamentals of Sound and Traffic Noise," vertical alignment changes can have a positive effect on the noise environment by reducing traffic noise levels at adjacent receivers.

3. An **increase in the number of through-traffic lanes**: applies to all highway projects that add at least one new permanent through-traffic lane regardless of whether the lane is added in the median or on the outside of the existing highway. For the purposes of a traffic noise analysis, a through-traffic lane is defined as a continuous main lane (including high occupancy vehicle lane) or frontage road.

4. **Low Volume Highways**

- a. Type I highway projects with a design year Average Daily Traffic of 1,200 vehicles per day or less will normally not result in a noise impact outside of the right of way.
- b. For these projects, an abbreviated analysis may be performed. For example, select a representative worst-case location on the right of way, determine the associated noise levels and document that the project will not result in any noise impacts outside the right of way. However, a higher than normal percentage of heavy trucks (above 3-5 percent) could result in a noise impact even for a low volume highway.

5. **Undeveloped Land**: when all land use activity areas adjacent to a highway project are undeveloped, with no development planned, designed or programmed, a complete traffic noise analysis is not required. However, it is important to calculate and clearly document predicted noise impact contours to assist local officials plan for future development that will, to the maximum extent possible, avoid traffic noise impacts.

C.

Analysis not
required

A noise analysis is not required for highway projects that are not considered Type I projects. An appropriate statement should be included in the environmental document.

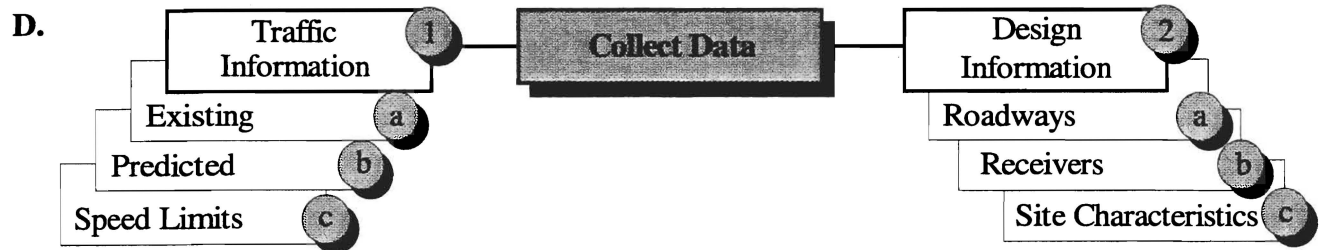

1. **Traffic Information:** As soon as it is determined that a traffic noise analysis will be required for a highway project, a request for existing and predicted traffic data should be submitted in writing to TxDOT's Transportation Planning and Programming Division (TPP). If this information is obtained from a source other than TxDOT/TPP, such as a Metropolitan Planning Organization or city planning staff, it should be provided to TxDOT/TPP for review and approval.

NOTE: Use Design Hourly Volume (DHV), not Average Daily Traffic (ADT) to model traffic noise levels.

- a. Existing Traffic: this should reflect the traffic data for the current (existing) year and roadways. This data may be collected on-site.
 - b. Predicted Traffic: this should reflect traffic data for the design year. The design year is normally 20 years from the current/existing year.
 - c. Speed Limits: normally, the posted speed limit is used to determine noise levels. However, the average operating speed may be used if it is determined to be consistently higher than the posted speed limit.
2. **Design Information:** The environmental process is initiated very early in the planning phase of a highway project; therefore, only preliminary information may be available. It is therefore critical to coordinate closely with the design staff to ensure the latest available information is used in the traffic noise analysis. It may be necessary to update the analysis several times before the final environmental document is completed.
 - a. Roadways: The overall highway project will normally need to be divided into many separate roadways that represent the different traffic flow patterns and changes in volume that collectively influence the calculations of noise levels. Normally, traffic noise levels can be accurately calculated by concentrating the noise source (traffic) along the centerline of each roadway.

b. **Receivers:** A receiver is identified by the specific location of an outdoor area adjacent to a highway project where frequent human activity occurs that might be impacted by highway traffic noise and may benefit from reduced noise levels. If no outdoor location can be identified, an interior location may be used.

(1) **Representative Receivers:** Not all receivers adjacent to a highway project need to be considered at the beginning of the analysis. One receiver may be used to represent the equivalent or worst case for several separate receivers in the same activity area. If there is no impact at this receiver, it is extremely unlikely that there will be an impact at any of the remaining receivers. However, if there is an impact at this "representative" receiver, it will be necessary to model additional receivers in the vicinity to determine how many will "benefit" from an abatement measure.

NOTE: Traffic sounds will normally not result in noise impacts for receivers located more than 150 meters from major freeways or more than 30-60 meters from lightly traveled roads.

(2) **Activity Areas:** Each receiver must be identified according to one of the following categories of land use activity areas, as defined by FHWA.

FHWA LAND USE ACTIVITY AREAS

<u>Category</u>	<u>Description of Land Use Activity Areas</u>
A	(Exterior) Lands on which serenity and quiet are of extraordinary significance and serve an important public need and where the preservation of those qualities is essential if the area is to continue to serve its intended purpose.
B	(Exterior) Picnic areas, recreation areas, playgrounds, active sports areas, parks, residences, motels, hotels, schools, churches, libraries and hospitals.
C	(Exterior) Developed lands, properties or activities not included in categories A or B above.
D	Undeveloped lands.
E	(Interior) Residences, motels, hotels, public meeting rooms, schools, churches, libraries, hospitals and auditoriums.

- (a) Category A: includes lands open to the public to serve a public need. An example of a Category A property would be an amphitheater where a quiet environment is of extreme importance. Few properties qualify as Category A areas.
- (b) Category B: includes those areas where the vast majority of outdoor human activity regularly occurs - primarily residential areas.
- (c) Category C: includes most commercial properties, businesses and office buildings.
- (d) Category D: includes undeveloped land and land held for speculative purposes. However, undeveloped lands for which development is planned, designed and programmed may be re-categorized accordingly.
 - 1 The terms “planned, designed, and programmed” mean that a definite commitment has been made to develop, or continue to develop, the property in question.
 - 2 A “definite commitment” is very difficult to determine and may vary greatly from one highway project to another depending on the nature of the project and adjacent development. However, first and foremost, the developer must possess a current approved building permit for the intended development.
 - 3 Also, in addition to the building permit, consider any other factors that could corroborate/confirm that construction is imminent and that the development will be carried through to completion. Such indicators might include any one or a combination of the following: the beginning or completion of the required infrastructure, the beginning or completion of a permanent structure, a previous history/record of successful development of a similar nature and/or the support and indorsement of local government or planning officials.
 - 4 For highway projects in rural areas that do not require a property owner/developer to obtain a building permit, the closest equivalent should be used along with the information in paragraph 3 above.

- (e) **Category E:** essentially represents interior noise levels for **Category B** properties. This category is used only in areas where there is little, if any, frequent human outdoor activity.
- c. **Site Characteristics:** As previously discussed in “Fundamentals of Sound and Traffic Noise,” there are a number of factors that affect the level of traffic sound/noise. For example, the level of traffic sounds may be reduced by elevated or depressed terrain, surface absorption, dense vegetation and/or shielding from buildings, fences or walls. Any/all of these factors that could affect the transmission of sound from the source to a receiver must be identified early in the traffic noise analysis.

E.

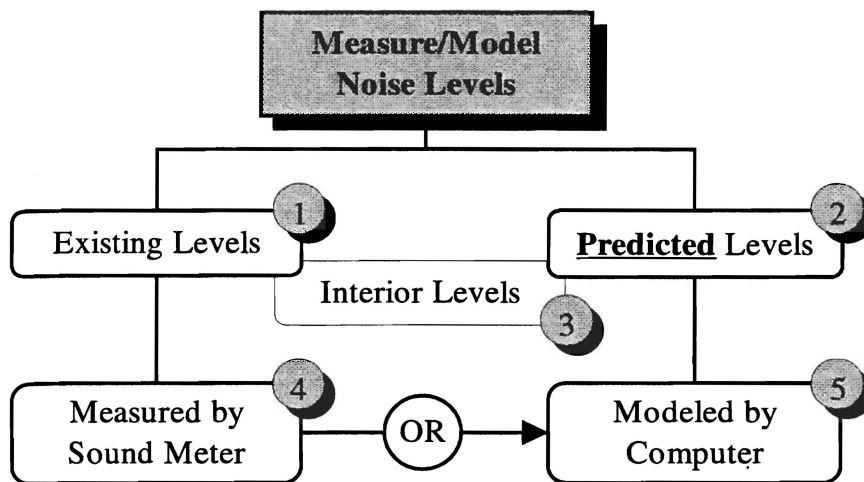

NOTE: L_{eq} noise levels are used for all traffic noise analyses of TxDOT highway projects.

1. Existing Levels:

- a. Traffic noise levels must be determined at representative receivers for the current (existing) pre-construction highway. For example, if a highway project will upgrade a roadway from two to four lanes, the existing levels should be based on data for the two-lane highway.
- b. Existing noise levels may either be determined through field measurements or by computer modeling. Because predicted levels can only be determined by computer modeling, existing levels should also be determined by computer modeling to ensure a direct comparison of noise levels obtained by the same methodology (exceptions are noted in paragraph 4 below).

- c. Existing noise levels by themselves are not used to determine when a noise impact occurs. They are used as the basis for calculating the increase in noise levels from the current/existing year to the design year.
- d. Existing noise levels are not required for undeveloped areas.

2. Predicted Levels

- a. Traffic noise levels must be determined at representative receivers for the completed highway project in the design year. For example, if a highway project will upgrade a roadway from two to four lanes, the predicted levels should be based on data for the four-lane highway in the design year.
- b. Predicted noise levels can only be determined by computer modeling.
- c. Predicted noise levels are not required for undeveloped areas where no development is planned, designed, or programmed. However, noise impact contours should be calculated and included in the environmental document to assist local officials plan for future development that will, to the maximum extent possible, avoid traffic noise impacts.

3. Interior Noise Levels

- a. As discussed earlier, noise levels are normally determined at receivers that are identified by the specific location of an outdoor area where frequent human activity occurs. However, in areas where there is little, if any, frequent human outdoor activity, an interior location may be used.
- b. An interior location would typically be used in areas where the human outdoor activity at a receiver is limited to a brief transition from a parking facility to an interior activity area (churches, hospitals, libraries, office buildings, businesses, etc.). This determination can only be made after a thorough on-site evaluation.
- c. Interior noise levels should be calculated by subtracting a noise reduction factor from exterior noise levels. Ideally, noise reduction factors obtained from field measurements or detailed acoustical analyses should be used. In the absence of such calculations or field measurements, the interior noise reduction factors in **Table 5** may be used.

Table 5: INTERIOR NOISE REDUCTION FACTORS		
Building Type	Window Condition	Noise Reduction
All	Open	10 dB
Light frame	Ordinary sash (closed)	20 dB
	Storm windows	25 dB
Masonry	Single glazed	25 dB
	Double glazed	35 dB

4. Field Measurements:

- a. Existing levels should be measured in situations where highway traffic may not be the dominant or most representative source of noise along a highway project. Aircraft, lawn equipment, trains, barking dogs, garbage trucks, farm equipment, construction equipment, etc., may produce noise levels that are higher than those associated with the highway traffic. This information would be an important consideration in the evaluation of any noise abatement measures.
- b. Field measurements can also assist in evaluating the level of noise reduction that may be provided by existing elements such as fences and vegetation that cannot be precisely modeled by computer. This information would be an important consideration in the determination of noise impacts and the evaluation of any associated noise abatement measures.
- c. Field measurements should be taken:
 - (1) during peak hour traffic or when the highest noise levels are expected. The period with the highest levels may not be at the peak traffic hour, but rather during some other period when traffic volumes may be lower but the overall percentage of trucks or vehicle speeds are higher. Consider the following:
 - (a) time of day (peak hour vs. any other time of day).
 - (b) day of the week (weekend vs. work day).

- (c) week of the year (tourist season vs. non-tourist season).
 - (2) when the roadway pavement is dry.
 - (3) when the wind speed is less than 15 mph.
 - (4) It is also necessary to physically count the number of vehicles, by type, for comparison with the traffic data provided by TxDOT/TPP. A 10 percent difference in traffic counts will produce a difference in noise levels of approximately 0.3 dB.
 - d. For statistical accuracy, each measurement should be taken in a minimum of 15-minute periods. Measurements along low-volume highways may require longer measurement periods (30-60 minutes) to attain desirable statistical accuracy.
 - e. Measurements should be made with sound meters of sufficient accuracy to yield valid data for the particular project (American National Standards Institute (ANSI) S1.4-1983, TYPE II or better).
5. **Computer Modeling:** Normally, both existing and predicted noise levels should be determined by computer modeling to ensure a direct comparison of noise levels obtained by the same methodology. A comprehensive user's manual containing specific information and procedures for using the latest FHWA approved traffic noise modeling software will be provided separately.

F.

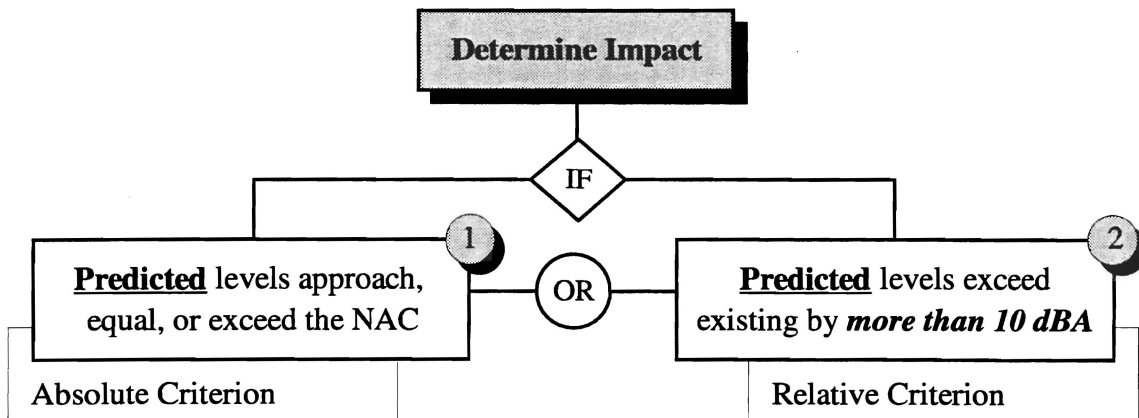

NOTE: A noise impact occurs when **either** the absolute **or** relative criterion is met. The key element in both criteria is the predicted (design year) noise levels.

1. **Absolute Criterion:** the predicted noise level at a receiver approaches, equals or exceeds the FHWA Noise Abatement Criteria (NAC) (Table 6).
 - a. "Approach" is defined as one (1) dBA below the NAC.
 - b. For example: a noise impact would occur at a Category B residence if the noise level is predicted to be 66 dBA or above.

Table 6: FHWA NOISE ABATEMENT CRITERIA (NAC)		
Activity Category	dBA Leq	Description of Land Use Activity Areas
A	57 (exterior)	Lands on which serenity and quiet are of extraordinary significance and serve an important public need and where the preservation of those qualities is essential if the area is to continue to serve its intended purpose.
B	67 (exterior)	Picnic areas, recreation areas, playgrounds, active sports areas, parks, residences, motels, hotels, schools, churches, libraries and hospitals.
C	72 (exterior)	Developed lands, properties, or activities not included in categories A or B above.
D	--	Undeveloped lands.
E	52 (interior)	Residences, motels, hotels, public meeting rooms, schools, churches, libraries, hospitals and auditoriums.

NOTE: The NAC are only to be used to determine impact. They are not used as a design goal for noise abatement measures.

2. **Relative Criterion:** the predicted noise level substantially exceeds the existing noise level at a receiver even if the predicted noise level does not approach, equal or exceed the NAC.
 - a. "Substantially exceeds" is defined as *more than 10 dBA*.
 - b. For example: a noise impact would occur at a Category B residence if the existing noise

level is *54 dBA* and the predicted noise level is 65 dBA (*11 dBA increase*).

NOTE: The relative criterion does not apply to undeveloped land.

3. When a noise impact occurs, noise abatement measures must be considered. A noise abatement measure is any positive action taken to reduce the impact of traffic noise on an activity area.

G. Abatement not required If the analysis indicates that a highway project will not result in any noise impacts, a discussion of noise abatement measures is not necessary and no further analysis is required.

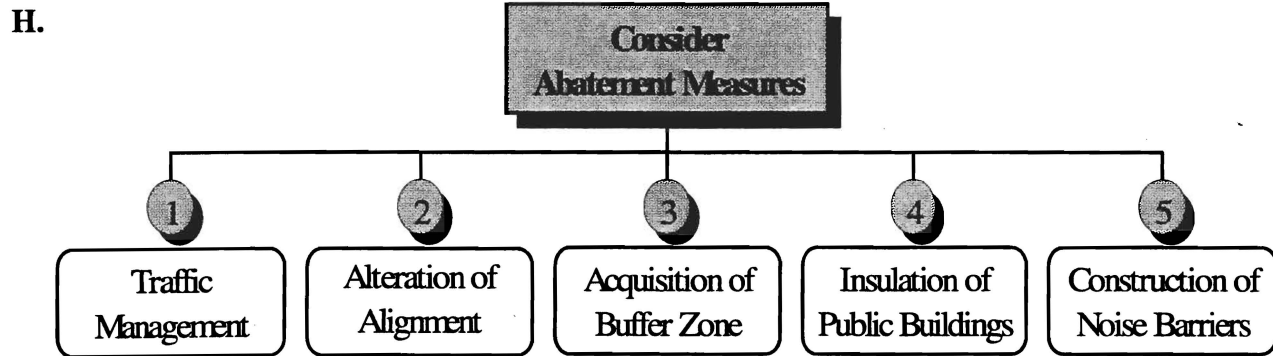

As stated earlier, a noise abatement measure is any positive action taken to reduce the impact of traffic noise on an activity area. When noise impacts occur, five specific noise abatement measures must be considered. Any consideration of abatement measures should include associated social, economic and environmental effects.

1. **Traffic Management:** includes prohibition and/or time use restrictions for certain vehicle types, reduction in speed limits, and traffic control devices.

Considerations:

- Adding traffic lights may lower noise levels by reducing speeds but may increase congestion and air pollution.
- Time or use restrictions for certain vehicles are prohibited on state highways.

- Lowering speed limits has only a minimal effect on noise levels. Lowering the speed limit by 5 mph will reduce the noise level by only 1 dB. Therefore, speed limits would need to be lowered by at least 25 mph to achieve a reduction that would be readily perceptible.

2. **Alteration of Alignment:** includes horizontal and vertical realignment of a roadway.

Considerations:

- Vertical and/or horizontal realignments can be extremely (prohibitively) costly.
 - Doubling the distance between a roadway and a receiver would reduce the noise level at the receiver by only 3-4.5 dBA. Such a realignment may not be practical, especially in urban areas.
 - Horizontal realignments may lower noise levels for receivers on one side of a roadway but will likely increase noise levels for receivers on the opposite side.
 - Vertical realignments could deny access to the highway from nearby activity areas.
 - Most highway projects involve improvements and/or modifications to existing roadways. Any realignments to existing roadways (of the scope required to effectively reduce noise levels) would not be practical or cost effective.
 - For highway projects on a new location, the avoidance or minimization of potential noise impacts should have been a consideration in the final alignment decision. Any alignment changes to reduce noise impacts could result in other, more costly environmental, social or economic impacts.
3. **Acquisition of Buffer Zone:** involves purchasing undeveloped/unimproved land, in addition to the normal right of way, to act as a noise buffer. Designed more as a measure to preclude future development that could be impacted by highway traffic noise, rather than to provide noise abatement for impacted receivers.

Considerations:

- A tremendous amount of land is required to provide an effective buffer.

- Property values for land adjacent to a highway project are normally prohibitively high, especially in urban areas.
- The potential use of buffer zones applies to unimproved property. This authority should not be used to purchase homes or developed property to create a noise buffer zone.

NOTE: For highway projects that involve the addition of a through-traffic lane, the three previous abatement measures normally will not provide a substantial noise reduction and/or will not be reasonable due to excessive costs.

4. **Insulation of Public Buildings:** includes insulation of public use or nonprofit institutional structures.

Considerations:

- Only considered for public use structures such as schools and hospitals.
- Does not include any private residences or businesses.
- Can be very costly: insulation normally includes sealing windows, cracks, and other openings that often result in the need for air conditioning.

5. **Construction of Noise Barriers:** this is the abatement measure that is most often used to reduce the impact of highway traffic noise on a receiver. Noise barriers are normally solid wall-like structures constructed between the noise source (traffic) and the impacted receivers. They can also be constructed from earth piled into a large mound or berm.

NOTE: Do not construct noise barriers on private property. Typically, noise barriers are constructed within the highway right of way.

Considerations:

- Noise barriers must be of sufficient length and height to effectively reduce noise levels. The FHWA approved computer model should be used to determine the optimum overall dimensions.
- Noise barriers are normally not effective for receivers on a hillside overlooking the

highway or for receivers at heights above the top of a noise barrier.

- It is normally not cost-effective to build a noise barrier for a single receiver.
- A noise barrier of sufficient height to break the line of sight from the receiver to the highway will normally result in a noise level reduction of 5 dBA.
- Large gaps for driveways and alleys entering onto a roadway greatly reduce the effectiveness of a barrier. However, small gaps and drainage holes (less than three percent of the total surface area) will not reduce overall effectiveness.
 - Access streets should not be closed to eliminate large gaps in a noise barrier and enhance the effectiveness of a noise barrier unless requested and approved by local government officials. Associated responsibilities should be clearly spelled out in a written agreement prior to the final environmental clearance.

NOTE: Traffic noise analyses and any associated noise abatement measures are not intended to be used as a means to reshape or reconfigure existing neighborhoods.

- Depressed and elevated roadways normally result in somewhat lower noise levels (3-5 dB) and, thereby, either eliminate the need for a noise barrier or result in a lower barrier than would be required for at-grade roadways (all other factors being equal).
- Earth berms, though natural in appearance, require a large area (right of way) to reach the height required to be effective.
- Project design engineers should be consulted when evaluating preliminary noise barrier locations (sight distance requirements, right-of-way issues, utility easements, foundation requirements, etc.).
- Noise barriers should not be proposed in locations that would cause any displacements or relocations.
- Highway traffic noise levels are not substantially increased by construction of a noise barrier on the opposite side of a highway from a receiver.
- Multiple reflections of traffic noise between two parallel plane surfaces, such as noise

barriers or retaining walls on both sides of a highway, can theoretically reduce the effectiveness of individual barriers and contribute to overall noise levels. However, associated increases in traffic noise levels will normally not be perceptible to the human ear if the distance between the barriers is at least 10 times the average height of the barriers. For example: two parallel barriers three meters in height should be constructed at least 30 meters apart.

- Noise Barrier Design: As indicated earlier, although a traffic noise analysis may include preliminary dimensions and locations of noise barriers, a detailed discussion of noise barrier design specifications and construction techniques is beyond the scope of this document. A comprehensive noise barrier design manual will be provided separately.

6. Other Noise Abatement Considerations

- a. Vegetation: the planting of vegetation should not be considered as a noise abatement measure.

(1) Roadside vegetation such as trees, shrubs and tall grasses provides little reduction in noise levels. Vegetation that is tall enough (4.5 meters), wide enough (30 meters), and dense enough that it cannot be seen through will decrease highway traffic noise by only a barely perceptible amount.

(2) Trees and shrubs provide psychological benefits and may be provided for visual, privacy or aesthetic treatment.

- b. Pavement: the use of specific pavement types or surface textures should not be considered as a noise abatement measure.

(1) Traffic noise levels do vary with changes in pavement; however, additional research is needed to determine if these variations are substantial when compared to the noise from a vehicle's exhaust and/or engine.

(2) It is very difficult to forecast the deterioration of pavement over time and any associated effects on traffic noise levels. Therefore, unless very definitive, verifiable data is available on a particular type of pavement, including its condition and noise generating characteristics, no adjustments for pavement type can be made in the prediction of highway traffic noise levels.

I.

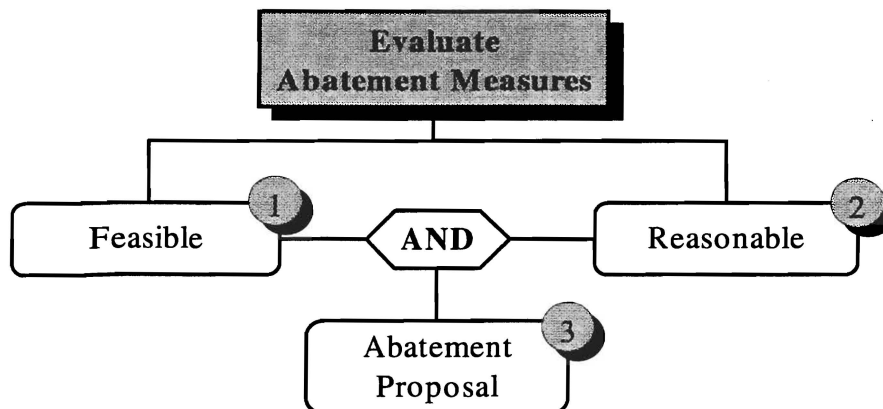

All noise abatement measures must be evaluated to determine if they are both feasible **AND** reasonable. Noise abatement measures that are both feasible **AND** reasonable should be proposed for incorporation into the highway project. A wide range of criteria is necessary to provide greater flexibility in abatement decision-making. Such flexibility is essential to allow consideration of special circumstances in individual cases.

1. **Feasible:** This evaluation criterion pertains to the ability of a noise abatement measure to provide a substantial reduction in noise levels, and deals primarily with engineering considerations.
 - a. "Substantial reduction" is defined as a reduction in noise levels of at least five dBA at impacted receivers, and is independent of the NAC.
 - b. Engineering considerations: Can a substantial reduction in noise levels be achieved given certain access, drainage, safety or maintenance requirements? Would any site characteristics (topography) prevent the construction of a noise barrier of sufficient size to achieve a substantial reduction in noise levels? Are other (non-traffic related) noise sources present in the area that would negate the ability of a traffic noise abatement measure to achieve a substantial reduction in noise levels?
2. **Reasonable:** This evaluation criterion primarily pertains to the cost effectiveness of a noise abatement measure and the views/desires of the public.
 - a. Cost effectiveness: a feasible noise abatement measure is considered to be cost effective if the total cost will not exceed \$25,000 for each benefitted receiver. For the purpose of this discussion, the following applies specifically to a noise barrier.

- (1) The \$25,000 figure includes only the cost of construction of a noise barrier and not the cost of any additional right of way or utility adjustments.
- (2) A noise barrier should be designed to achieve a substantial reduction (at least five dBA) in noise levels at the lowest cost to the taxpayer.
- (3) Benefitted receiver: in order for a receiver to be counted as benefitted, a noise abatement measure must reduce the noise level at the receiver by at least five dBA, regardless of whether or not the receiver was impacted. For the purpose of this discussion, the following applies specifically to a noise barrier.

Considerations for counting benefitted receivers for specific types of activity areas:

- Homes, apartments, condominiums and permanent mobile home parks (owner-occupied or rental): Count each single-family residence and each unit in a duplex, apartment or condominium complex. Include only **first-floor** receivers.
- Parks: Noise abatement for a park should be determined by the associated types of activities. Parks with picnic or walking/jogging areas near the right of way may be more appropriate for noise abatement than parks that are used primarily for team sports. Major activity areas within a park (playgrounds, picnic tables, etc) may be counted as separate receivers.
- Schools, churches, hospitals, rest homes and day care centers: These facilities should be examined on a case-by-case basis.
- Commercial businesses and office buildings: Count each first-floor property. Typically, owners of commercial properties will oppose a noise barrier because of access and visibility restrictions for potential customers.

NOTE: To determine the total number of benefitted receivers, the minimum noise level reduction of five dBA is applied to each receiver individually - do not average noise level reductions for multiple receivers. For example: if noise level reductions for three receivers are calculated to be four, six and five dBA, only the two receivers with noise level reductions of six and five dBA are counted as benefitted even though the average of all three receivers is five dBA.

- b. The views/desires of the public (see "Public Involvement").
 - c. Additional consideration: the extent to which the local government agency responsible for approval of development has demonstrated the control of (or has agreed to control) land use activities adjacent to the highway that encourages noise compatible development, especially when the agency has been given prior notice of potential traffic noise impacts.
3. **Abatement Proposal:** As stated earlier, noise abatement measures that are both feasible **AND** reasonable should be proposed for incorporation into the highway project. The following discussion assumes that a highway project will result in a noise impact and that a noise barrier is being proposed as a feasible and reasonable abatement measure.
- a. Initial proposal: provide sufficient information in the environmental document to verify that a proposed noise barrier is both feasible and reasonable, including (as a minimum):
 - (1) Approximate location and dimensions (length and height).
 - (2) Number of benefitted receivers.
 - (3) Total cost and cost for each benefitted receiver.
 - b. Interim approval: when available, provide a detailed noise barrier analysis to TxDOT/ENV for review and approval for further processing in the public involvement phase - public review and approval. This study should provide as much detail as possible, including a graphical depiction of the proposed barrier(s) relative to the benefitted receiver(s) and associated estimates of noise level reductions and costs.
- NOTE:** A noise barrier proposal can be taken directly to the public for review and approval without this interim approval if a detailed noise barrier analysis was provided in the approved environmental document and no substantial changes have occurred.
- c. Final approval: following final public approval, (re)submit the noise barrier analysis, along with the results of the public involvement process and any changes, to TxDOT/ENV for approval and submittal to FHWA, as appropriate.
 - d. Any substantial changes in the design of a highway project may require a reevaluation

of a proposed noise abatement measure. The final decision to implement a noise abatement proposal cannot be made until the completion of the project design and the public involvement process.

J.

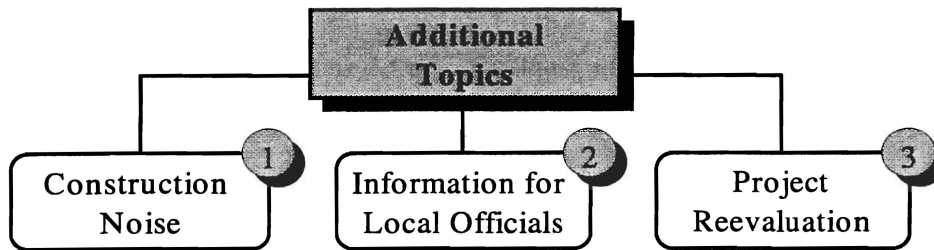

1. **Construction Noise:** The potentially adverse effects of noise from construction equipment associated with the highway project must be addressed in the environmental document.
 - a. The calculation of noise levels for highway construction equipment is normally not required in a traffic noise analyses.
 - b. Construction noise should be addressed in a general manner with emphasis on the temporary nature of any adverse effects.
 - c. Low-cost, easy-to-implement measures to reduce/minimize construction noise should be included in the plans and specifications for a highway project (e.g., work-hour limits, equipment muffler requirements, etc.)
2. **Information for Local Officials:** The final subject that must be addressed in the traffic noise analysis is the information to be provided to local officials.
 - a. Local officials in jurisdictions that may be affected by the highway project must be informed of existing and predicted traffic noise levels to ensure, to the maximum extent possible, future developments are planned, designed and programmed in a manner that will avoid traffic noise impacts.
 - (1) For projects that have a substantial amount of undeveloped land adjacent to the highway, it is important that the traffic noise analysis include predicted noise impact contours at appropriate distances from the highway. As a minimum, these distances should equate to the predicted 66 dBA and 71 dBA noise levels - where noise impacts would occur for residential and commercial receivers, respectively.

- (2) Local officials should also be informed that on the date of approval of the environmental document (Date of Public Knowledge) FHWA and TxDOT are no longer responsible for providing noise abatement for new development adjacent to a proposed highway project.
- b. Local officials responsible for approving plat requests for future development adjacent to the project should be encouraged to include a statement on the plats indicating that the developer will be responsible for either avoiding traffic noise impacts or providing any associated noise abatement.

3. Project Reevaluation

- a. A traffic noise analysis and any associated noise abatement proposals may need to be reevaluated if substantial highway design and/or land use changes occur before the date of approval of the environmental document.
- b. A reevaluation may also be required between the date of approval of the environmental document and the date the project, or phase of a project, is let for construction if substantial highway design and/or land use changes occur during unforeseen delays in construction or between separate phases of construction.

THIS PAGE
INTENTIONALLY LEFT BLANK

VI. PUBLIC INVOLVEMENT: The views and desires of the public are major considerations throughout the traffic noise analysis process, especially when noise impacts are identified and noise abatement measures are considered. As stated earlier, the construction of a noise barrier is the most frequently proposed noise abatement measure. For this reason, the following discussion will focus on public perception, notification and approval of a noise barrier proposal.

A. Public Perception: Noise barriers are meant to be a positive addition to a neighborhood and are normally well received. However, noise barriers are not always right for all people in all neighborhoods.

1. **Positive:** Noise barriers can improve the quality of life in areas adjacent to highways by reducing traffic noise levels to a point that creates a more peaceful and restful environment for indoor and outdoor activities.
2. **Negative:** Although noise barriers can effectively reduce traffic noise levels, they can also result in restricted views; feelings of confinement; noticeable reductions in air circulation, sunlight and night lighting; limited access to nearby streets; and graffiti. Also, noise barriers could present a serious financial problem for commercial businesses by restricting views and access by potential customers.

B. Public Notification: Affected property owners should be notified that a noise barrier is being considered for incorporation into a highway project when sufficient information is available to adequately define, as a minimum, the overall dimensions and location of the associated noise barrier. The initial public notification of a noise barrier proposal may not occur until the public meeting/hearing for the overall environmental document.

1. **Required notification:** owners of property adjacent to a proposed noise barrier.
 - a. The notification should be accomplished by any reasonable and easily verifiable means. For example: personal contact at a public meeting/hearing or certified mail with a return receipt requested.
 - b. The notification might include any/all of the following:
 - a clear concise description (dimensions/location) of the proposed noise barrier.
 - a survey, questionnaire and/or ballot, as appropriate.

- a copy of the noise barrier brochure published by TxDOT/ENV.
 - an invitation to attend a separate noise workshop, as necessary.
 - any available comments and opinions from respective tenants.
 - any proposed changes/updates, as appropriate.
2. Recommended notification: all remaining impacted and benefitted property owners and tenants should also be notified by whatever means that will ensure maximum visibility, coverage and response.

C. Public Approval

1. No noise barrier will be constructed without the approval, by simple majority vote, of the owners of property adjacent to the proposed noise barrier.
 - a. Each qualifying owner is allowed one vote.
 - b. If possible/practical, each qualifying owner should be provided any available comments and opinions from their respective tenants.
2. In a similar manner, owners of property adjacent to the proposed noise barrier should also be given an opportunity to provide comments on the selection of surface treatment and color for the proposed noise barrier - from a selection provided by TxDOT.

D. Date of Public Knowledge: the date of approval of the environmental document (CE, EA/FONSI or EIS) for a highway project - when federal and state governments are no longer responsible for providing noise abatement for new development adjacent to a proposed highway project.

VII.

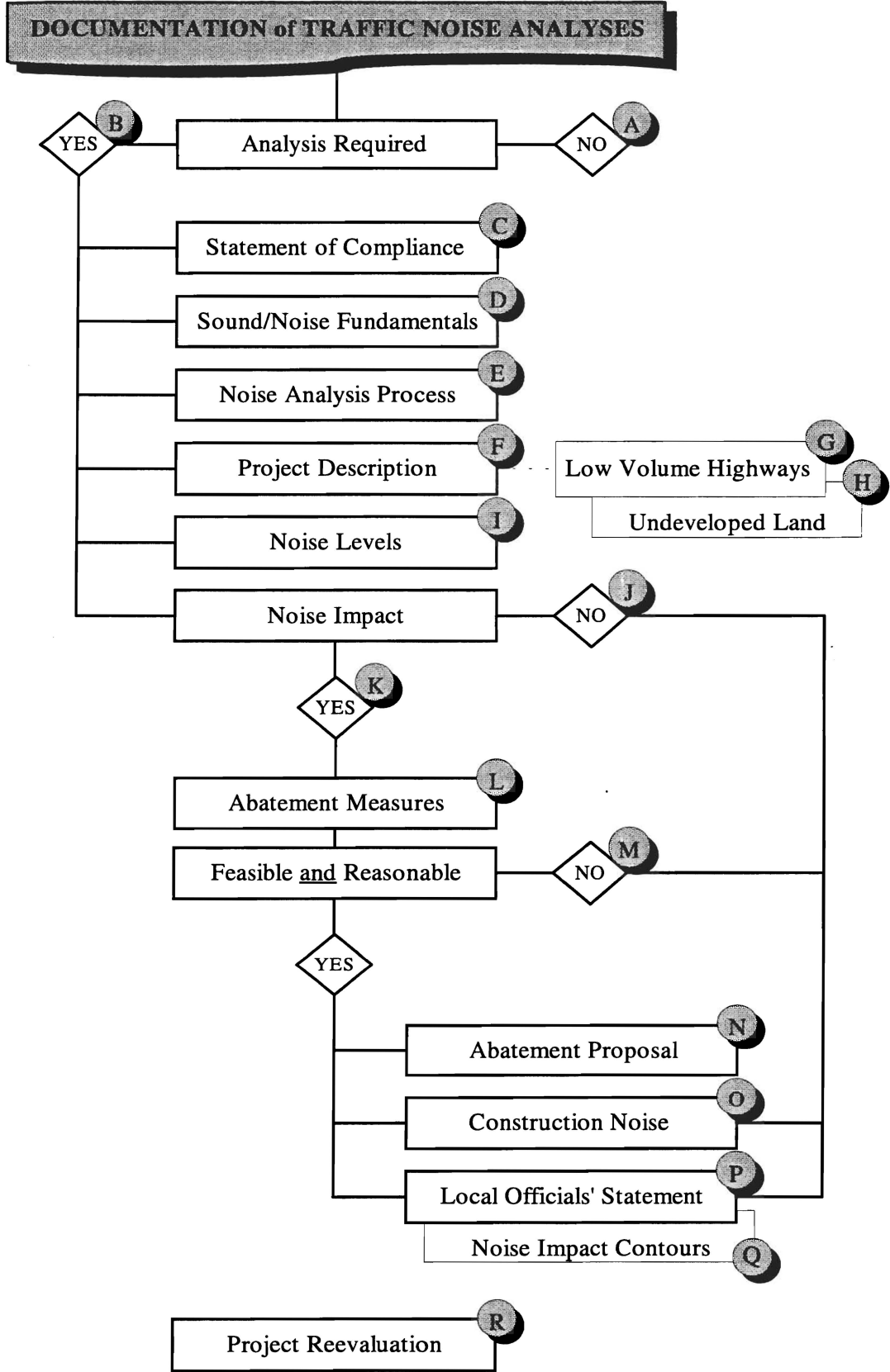

The following discussion provides a brief explanation of each topic that should be addressed in the documentation of a traffic noise analysis, and includes examples of recommended text in *italics*.

NOTE: A computer disk containing recommended text and associated tables is available upon request from TxDOT/ENV.

A. Traffic Noise Analysis Not Required: briefly explain why a traffic noise analysis was not required.

This project is not on a new location, does not substantially alter either the horizontal or vertical alignment, and does not increase the number of through-traffic lanes; therefore, a traffic noise analysis is not required by FHWA Regulation 23 CFR 772 or TxDOT's 1996 Guidelines for Analysis and Abatement of Highway Traffic Noise.

B. Traffic Noise Analysis Required: documentation of the traffic noise analysis should be clear, concise and accurate. It should be presented in a "stand-alone" format - all information pertinent to traffic noise presented in one place even if some of the information, such as traffic data or land use descriptions, is included elsewhere in the document.

C. Statement of Compliance: indicate that the traffic noise analysis conforms to federal regulations and policy, and state guidelines.

This analysis conforms to FHWA Regulation 23 CFR 772, "Procedures for Abatement of Highway Traffic Noise and Construction Noise," and TxDOT's 1996 Guidelines for Analysis and Abatement of Highway Traffic Noise.

D. Sound/Noise Fundamentals: provide sufficient information for the reader to understand the basic terms and concepts used in a traffic noise analysis. This is essentially generic information that should be used consistently for all highway projects, as appropriate.

Sound from highway traffic is generated primarily from a vehicle's tires, engine and exhaust. It is commonly measured in decibels and is expressed as "dB."

Sound occurs over a wide range of frequencies. However, not all frequencies are detectable by the human ear; therefore, an adjustment is made to the high and low frequencies to approximate the way an average person hears traffic sounds. This adjustment is called A-weighting and is expressed as "dBA."

Also, because traffic sound levels are never constant due to the changing number, type and speed of vehicles, a single value is used to represent the average or equivalent sound level and is expressed as "L_{eq}"

COMMON SOUND/NOISE LEVELS		
OUTDOOR	dBA	INDOOR
Pneumatic hammer	100	Subway train
Gas lawn mower at 1 meter		
	90	Food blender at 1 meter
Downtown (large city)	80	Garbage disposal at 1 meter
		Shouting at 1 meter
Lawn mower at 30 meters	70	Vacuum cleaner at 3 meters
Commercial area		Normal speech at 1 meter
Air conditioning unit	60	Clothes dryer at 1 meter
Babbling brook		Large business office
Quiet urban (daytime)	50	Dishwasher (next room)
Quiet urban (nighttime)	40	Library

E. Noise Analysis Process: briefly outline the overall traffic noise analysis process with emphasis on the criteria used to determine when noise impacts occur. Also indicate the method (field measurement and/or computer model) used to determine traffic noise levels.

The traffic noise analysis typically includes the following elements:

- *Identification of land use activity areas that might be impacted by traffic noise.*
- *Determination of existing noise levels.*
- *Prediction of future noise levels.*
- *Identification of possible noise impacts.*
- *Consideration and evaluation of measures to reduce noise impacts.*

The FHWA has established the following Noise Abatement Criteria (NAC) for various land use activity areas that are used as one of two means to determine when a traffic noise impact will occur.

FHWA NOISE ABATEMENT CRITERIA (NAC)		
Activity Category	dBA Leq	Description of Land Use Activity Areas
A	57 (exterior)	Lands on which serenity and quiet are of extraordinary significance and serve an important public need and where the preservation of those qualities is essential if the area is to continue to serve its intended purpose.
B	67 (exterior)	Picnic areas, recreation areas, playgrounds, active sports areas, parks, residences, motels, hotels, schools, churches, libraries and hospitals.
C	72 (exterior)	Developed lands, properties or activities not included in categories A or B above.
D	--	Undeveloped lands.
E	52 (interior)	Residences, motels, hotels, public meeting rooms, schools, churches, libraries, hospitals and auditoriums.

A noise impact occurs when either the absolute or relative criterion is met:

Absolute criterion: the predicted noise level at a receiver approaches, equals or exceeds the NAC. "Approach" is defined as one dBA below the NAC. For example: a noise impact would occur at a Category B residence if the noise level is predicted to be 66 dBA or above.

Relative criterion: the predicted noise level substantially exceeds the existing noise level at a receiver even though the predicted noise level does not approach, equal or exceed the NAC. "Substantially exceeds" is defined as **more than 10 dBA**. For example: a noise impact would occur at a Category B residence if the existing level is 54 dBA and the predicted level is 65 dBA (11 dBA increase).

When a traffic noise impact occurs, noise abatement measures must be considered. A noise abatement measure is any positive action taken to reduce the impact of traffic noise on an activity area.

The FHWA Traffic Noise Model was used to calculate existing and predicted traffic noise levels. The model primarily considers the number, type and speed of vehicles; highway alignment and grade; cuts, fills and natural berms; surrounding terrain features; and the locations of activity areas likely to be impacted by the associated traffic noise.

- F. Project Description:** briefly and concisely outline the key elements of the project that were used to determine traffic noise levels, including: traffic data (ADT), adjacent land use activity areas and representative receivers. It is not necessary to include a lengthy discussion of peak traffic times, levels of service, speed limits or vehicle mix. A simple diagram (figure) should be included to graphically depict the location of the receivers relative to the highway project.

Existing and predicted traffic noise levels for XXXX vehicles per day in 19XX and XXXX vehicles per day in 20XX were modeled at XX Category B and C receivers (Figure X) that represent the residences and commercial businesses adjacent to the highway project that might be impacted by traffic noise and that may potentially benefit from reduced noise levels.

- G. Low Volume Highways** (design year traffic of 1,200 vehicles per day or less): briefly provide the associated traffic data and the noise levels at a worst-case location (right of way or nearest receiver), and simply indicate, if appropriate, that the project will not result in any noise impacts.

Existing and predicted traffic noise levels for 600 vehicles per day in 19XX and 900 vehicles per day in 20XX were modeled at a representative worst case location on the right of way. The predicted noise level (XX) exceeded the existing level (XX) by only X dBA and the NAC for Category B was not approached, equaled or exceeded. Therefore, the project will not result in a traffic noise impact outside the right of way and a consideration of noise abatement measures is not required.

- H. Undeveloped Land:** when all land use activity areas adjacent to a highway project are undeveloped and no development is planned, designed or programmed, it is only necessary to provide predicted noise impact contours to assist local officials plan for future development that will avoid traffic noise impacts (see “Noise Impact Contours”).

I. **Noise Levels:** present the existing and predicted noise levels and associated data in tabular form.

TABLE XX: TRAFFIC NOISE LEVELS (dBA Leq)						
Receiver	NAC Category	NAC Level	Existing 19XX	Predicted 20XX	Change (+/-)	Noise Impact
R1						
R2						
R3	<p><i>NOTE: Document all noise levels in whole numbers. Do not round to the nearest whole number -- simply drop the number after the decimal point.</i></p>					
R4						
R5						
R6						
R7						

J. **No Noise Impact:** let the traffic noise level table speak for itself - simply indicate that the project will not result in a traffic noise impact.

As indicated in Table XX, predicted noise levels exceed existing levels by a maximum of only X dBA and the NAC was not approached, equaled or exceeded at any receiver. Therefore, the project will not result in a traffic noise impact.

K. **Noise Impact:** again, let the traffic noise level table speak for itself - simply summarize the results and highlight the number of impacted receivers.

As indicated in Table XX, predicted noise levels exceed existing levels by a maximum of only X dBA; however, the NAC was approached, equaled or exceeded at X receivers. Therefore, the project will result in a traffic noise impact and the following noise abatement measures were considered: traffic management, alteration of horizontal and/or vertical alignments, acquisition of undeveloped property to act as a buffer zone and the construction of noise barriers.

L. **Abatement Measures:** briefly address the meaning of the “feasible” and “reasonable” evaluation criteria. Summarize all relevant considerations for each noise abatement measure. Normally, all impacted receivers can be considered as a group; however, there may be occasions

when impacted receivers should be considered individually or in groups according to land use activity category. Also, if none of the impacted receivers is a public use or nonprofit institutional structure, the noise abatement measure to insulate public buildings can be omitted from the discussion.

Before any abatement measure can be incorporated into the project, it must be both feasible and reasonable. In order to be feasible, the measure should reduce noise levels by at least five dBA at impacted receivers; and to be reasonable it should not exceed \$25,000 for each benefitted receiver.

Traffic management: control devices could be used to reduce the speed of the traffic; however, the minor benefit of one dBA per five mph reduction in speed does not outweigh the associated increase in congestion and air pollution. Other measures such as time or use restrictions for certain vehicles are prohibited on state highways.

Alteration of horizontal and/or vertical alignments: any alteration of the existing alignment would displace existing businesses and residences, require additional right of way and not be cost effective/reasonable.

Buffer zone: there is no undeveloped or unimproved land adjacent to the highway project that could be acquired to preclude future development that could be impacted by highway traffic noise.

OR

the acquisition of sufficient undeveloped land adjacent to the highway project to preclude future development that could be impacted by highway traffic noise would not be cost effective/reasonable.

Noise barriers: this is the most commonly used noise abatement measure. However, for this project, a noise barrier would severely restrict access to adjacent activity areas. Numerous gaps in the noise barrier would satisfy access requirements but would render the barrier ineffective (infeasible). Also, noise barriers could have a detrimental impact on nearby businesses by restricting views and access by potential customers. Finally, a noise barrier would not be cost effective for an individual receiver.

M. No Abatement Measures are Feasible and Reasonable: if none of the noise abatement measures were evaluated to be feasible and reasonable, include an appropriate statement.

None of the above noise abatement measures are both feasible and reasonable; therefore, no abatement measures are proposed for this project.

N. Abatement Proposal: for most highway projects, a noise barrier will be the only noise abatement measure that is feasible and reasonable. Include as much detail as possible regarding the proposed dimensions, number of benefitted receivers, total cost of the barrier and the cost for each benefitted receiver.

Noise barriers: A noise barrier was determined to be both feasible and reasonable and is, therefore, proposed for incorporation into the project. Based on preliminary calculations, a noise barrier XXX meters in length and X.X meters in height will reduce noise levels by at least 5 dBA for X benefitted receivers (RX, X, X, X and X) at a total cost of \$XXX,XXX or \$XX,XXX for each benefitted receiver. Any subsequent project design changes may require a reevaluation of this proposal. The final decision to construct the proposed noise barrier will be made upon completion of the project design and the public involvement process.

Optional Table (multiple barriers)

TABLE XX: NOISE BARRIER PROPOSAL (preliminary)					
Barrier	#Benefitted Receivers	Length (meters)	Height (meters)	Total Cost*	\$/Benefitted Receiver
1					
2					
3					
4					
5					
6					

* Based on estimated construction costs of \$XX per square meter.

O. Construction Noise: briefly indicate that some noise will result from the actual construction of the project and indicate that appropriate steps will be taken to minimize any potentially adverse effects.

Noise associated with the construction of the project is difficult to predict. Heavy machinery, the major source of noise in construction, is constantly moving in unpredictable patterns. However, construction normally occurs during daylight hours when occasional loud noises are more tolerable. None of the receivers is expected to be exposed to construction noise for a long duration; therefore, any extended disruption of normal activities is not expected. Provisions will be included in the plans and specifications that require the contractor to make every reasonable effort to minimize construction noise through abatement measures such as work-hour controls and proper maintenance of muffler systems.

- P. Local Officials' Statement:** briefly indicate that a copy of the traffic noise analysis will be provided to local officials in affected jurisdictions to assist in future land use planning. It is not necessary to provide a copy of 23 CFR 772 since traffic noise analyses conducted/documented according to TxDOT guidelines contain pertinent information from, and conform to, 23 CFR 772. Also, it is important to address noise abatement responsibilities following the Date of Public Knowledge.

A copy of this traffic noise analysis will be provided to local officials to ensure, to the maximum extent possible, future developments are planned, designed and programmed in a manner that will avoid traffic noise impacts. On the date of approval of this document (Date of Public Knowledge), FHWA and TxDOT are no longer responsible for providing noise abatement for new development adjacent to the project.

- Q. Noise Impact Contours:** for projects that have a substantial amount of undeveloped land adjacent to the highway, the traffic noise analysis should include predicted noise impact contours at appropriate distances from the highway project. As a minimum, these distances should equate to the predicted 66 dBA and 71 dBA noise levels - where noise impacts would occur for residential and commercial receivers, respectively. Ideally, these contours should be graphically depicted on a plan view of the overall project; however, a simple tabular presentation will suffice.

Land use activity areas adjacent to the project are currently Category D, undeveloped land. Also, no new development is currently planned, designed or programmed in these areas. There is no NAC for undeveloped land; therefore, the project will not result in any noise impacts. However, to avoid noise impacts that may result from future development of properties adjacent to the project, local officials responsible for land use control programs should ensure, to the maximum extent possible, no new activities are

planned or constructed along or within the following predicted (20XX) noise impact contours. On the date of approval of this document (Date of Public Knowledge), FHWA and TxDOT are no longer responsible for providing noise abatement for new development adjacent to the project.

<u>LAND USE</u>	<u>IMPACT CONTOUR</u>	<u>DISTANCE from RIGHT of WAY</u>
<i>Residential</i>	<i>66 dBA</i>	<i>XX meters</i>
<i>Commercial</i>	<i>71 dBA</i>	<i>XX meters</i>

R. Project Reevaluation: As indicated earlier, substantial highway design and/or land use changes that occur before the date of approval of the environmental document may require a reevaluation of the traffic noise analysis and any associated noise abatement proposal. Also, a traffic noise analysis may need to be reevaluated between the date of approval of the environmental document and the date the project, or phase of a project, is let for construction if substantial highway design and/or land use changes occur during unforeseen delays in construction or between separate phases of construction.

The scope of a reevaluation depends on the nature of any changes in the project itself, FHWA regulations, and/or TxDOT guidelines that could substantially alter the outcome of the original traffic noise analysis. For example: if project changes would likely result in noise impacts where none were previously identified (or vice versa) or if L_{10} noise levels were used instead of L_{eq} , a new traffic noise analysis should be performed. However, if the outcome would likely remain the same, a brief explanation in a cover letter/memo may suffice. The following might apply to a project that has been delayed more than three years since the environmental clearance was received.

The original traffic noise analysis concluded that no noise abatement measures were feasible and reasonable for any of the impacted receivers. Since that time, there have been no changes that would alter this conclusion; therefore, the original traffic noise analysis remains valid.

NOTE: Do not include excessive details or overly technical data, such as computer input/output files or field logs, in the documentation of a traffic noise analysis. However, all pertinent information should be maintained on file for future reference, as necessary.