

EVALUATION OF OVERHEAD SIGN BACKGROUND MATERIALS  
AND MERCURY VAPOR SIGN LIGHTS

Research Report Number 222-1

Research Project 1-18-75-222

by

H. Dexter Jones  
Supervising Designing Engineer  
Houston Urban Office

and

Joseph G. Raska  
Materials and Tests Paint Engineer  
Materials and Tests Division



Conducted by

Houston Urban Office and Materials and Tests Division  
In Cooperation with the  
Transportation and Planning Division  
Texas State Department of Highways and Public Transportation

February 1979

## ACKNOWLEDGEMENTS

The authors wish to give special acknowledgement to Richard H. Oliver, and Devidas B. Tulsiani of Maintenance Operations Division, John F. Nixon of Transportation Planning Division, Thaddeus Bynum of Highway Design Division, John N. Lipscomb of District 12, and Waid D. Goolsby of District 18, for timely comments and guidance in this project.

Also, special thanks are given to Districts 12 and 16 Sign Shop personnel for preparing signs, and to District 12 Maintenance personnel for erection of signs and sign lights on the roadway.

## ABSTRACT

Coating materials based on thermal setting polyester, thermal setting polyvinylidene fluoride, and air dry polyvinylidene fluoride have been found to be satisfactory coating materials for Overhead Guide Signs.

The above three coatings also show excellent promise as materials for refurbishing deteriorated porcelain-enameled aluminum Overhead Guide Signs.

Coatings based on polyurethane, vinyl toluene/acrylate copolymers, acrylic and alkyd do not produce overhead guide sign backgrounds of sufficient durability and color retention to warrant their use.

Overhead Guide Signs can be illuminated to sufficient target value and uniformity with certain 100-watt mercury vapor lighting units.

Most 175- and 250-watt mercury vapor lighting units present legibility washout problems, in particular the 250-watt units.

## SUMMARY

Materials possibly suitable for overhead sign backgrounds, such as polyester, polyvinylidene fluoride, polyurethane, vinyl toluene acrylate, acrylic and alkyd, have been studied in the field and by accelerated tests. In addition to evaluating the above new materials, a survey has been made of materials used for the last fifteen years or so. These materials are various forms of porcelain enamel, acrylic film and polyvinyl fluoride film. Durability and color retention of sign backgrounds utilizing vinyl toluene acrylate, acrylic and alkyd are relatively short and therefore the use of these materials is not economically feasible.

Results of polyurethane are conflicting to date, but it too will probably be in the list of non-feasible materials.

All tests to date (field and accelerated) show strong indications that sign backgrounds utilizing polyester or polyvinylidene fluoride will give excellent durability and color retention for a minimum of ten years. Specifications for polyvinylidene fluoride and polyester sign backgrounds have been prepared.

Porcelain-enameled extrusion sign backgrounds began to exhibit color retention problems within two to three years along the coast of Texas and in industrial atmospheres. In the remainder of the state, color retention problems became quite noticeable in eight to ten years.

Porcelain-enameled aluminum honeycomb began to show color retention problems the same as extrusion, but, in addition, immediately exhibited buckling problems. Honeycomb also exhibited corrosion problems within five years along the coats, and in approximately ten years in the remainder of the state.

Thermal setting polyester, thermal setting polyvinylidene fluoride, and air dry polyvinylidene fluoride appear to be excellent materials for refurbishing existing deteriorated porcelain aluminum sign panels at approximately half the cost of a new sign panel. At the present time, it appears that the color retention of the refurbished panel will be better than a new porcelain panel.

Illumination of overhead signs with mercury vapor lighting units has been studied utilizing 250-, 175- and 100-watt mercury vapor units. The study results show that overhead signs up to fourteen feet in height can be illuminated with satisfactory uniformity, legibility and target value with certain 100-watt mercury vapor units. Results of visual observations show that as the wattage dropped, uniformity and legibility increased and target value dropped slightly. Legibility washout is a problem with most 250-watt mercury vapor units.

## IMPLEMENTATION

In order for the Department to realize the optimum return from the monies expended on this project, to enjoy the full benefits of a competitive market, and to experience a minimum of material problems, the Department has adopted the Overhead Guide Sign specification and Sign Lighting specifications developed by this project for statewide use.

Since existing 250-watt mercury vapor sign lighting installations require maintenance in the form of new ballasts, it is recommended that lighting units be converted on a replacement basis to 100- and 175-watt systems. Information on which 250-watt units can be successfully converted to 100- or 175-watts and retain satisfactory sign lighting criteria is obtainable from the Materials and Tests Division, Section B, Austin, Texas.

I. SUBJECT:

Evaluation of Overhead Sign Background Materials and Mercury Vapor Sign Lighting Fixtures.

II. PURPOSE:

The objects of this study are:

A. Evaluate available coatings that show promise of producing satisfactory overhead sign backgrounds.

B. Determine the feasibility of illuminating overhead signs with mercury vapor lighting fixtures.

An additional object of this study incorporated after the study began was to determine a feasible and satisfactory method to reclaim existing deteriorated porcelain-enameled extrusions.

III. CONCLUSIONS AND RECOMMENDATIONS:

Thus far, three coatings have been found that will produce satisfactory backgrounds for overhead signs. These are polyvinylidene fluoride (thermal setting and air dry) and polyester (thermal setting). The above three coatings show promise as coatings for refurbishing porcelain-enameled extrusions.

Photometric tests and visual observations of field installations show that overhead signs can be illuminated effectively with the use of 100-watt mercury vapor sign lighting fixtures.

Specifications have been prepared for polyvinylidene fluoride and polyester coatings, and for the 100-watt mercury vapor sign lighting fixture. These specifications have been adopted for statewide use.

IV. MATERIALS:

Primarily, the materials evaluated thus far are polyvinylidene fluoride (thermal setting and air dry), thermal setting polyester, polyurethane, vinyl toluene/acrylate copolymer, acrylic and alkyd. Substrates being evaluated are aluminum and high density plastic face plywood.

V. EQUIPMENT:

Sign lighting equipment from ten manufacturers was evaluated. In order to evaluate the photometrics, a simulated test sign and light mounting rack were made. Actual footcandle measurements were made with a Tektronix J-16 Light Meter utilizing a J-6511 probe.

An Atlas Weatherometer was utilized for accelerated testing and a test fence facing southeast at 45° over salt water at Nueces Bay near Corpus Christi was utilized for accelerated weathering.

Color was determined on a Gardner Color Difference Meter. Infrared characteristics of coating materials were determined with a Perkin-Elmer 521 Grating Infrared Spectrophotometer. X-ray analysis of coating materials was determined with a Philips X-ray Diffractometer.



## VI. PROCEDURE FOR DATA:

Performance data, such as durability with respect to chalking and color retention, is being evaluated in the field, on test fences, and in the weatherometer. Most of the test panels were produced at the same time panels for complete signs were manufactured. In some cases where results appeared to be conflicting, additional test panels were prepared in the D-9 Laboratory in Austin. Infrared spectra and X-ray diffraction patterns were run using routine techniques on the applied materials and unapplied materials, when possible, primarily for identification purposes.

To facilitate photometric testing of sign lighting units, a 12-foot by 20-foot simulated sign was made of plywood painted green. The entire sign face was then laid off on a one-foot grid. The simulated sign face was oriented in a horizontal position.

Along the full length of one long side of the simulated sign face, a vertical rack was built that would allow mounting of sign lights above the edge of the sign face from 3.5 feet to 5.5 feet in one foot increments. The rack for mounting sign lights was made so that spacing between sign light units was variable up to 20 feet when testing two units, or 10 feet when testing three units at a time.

### VIII. DISCUSSION:

Since the advent of multi-lane freeways and the interstate highway system, a new technique of highway signing has evolved -- Overhead Signing. Overhead signing has created a multitude of problems in an effort to solve one traffic engineering problem: How does one make an in-place, legible, maintenance free sign unit with pleasing aesthetics that will fulfill the needs of the motorist? The problems seem simple, yet this is a complete departure from signing on the roadway shoulder. The mounting, available materials, and accessibility to shoulder mounted signs becomes easy when compared to overhead signing.

Needless to say, the problems were defined and resolved one by one until, as a final result, overhead signing has become an effective, working identity on the roadway.

When overhead signing first became a reality, few materials were available that could be adapted to such uses. Porcelain enameled aluminum was the only material available at the time to fabricate sign backgrounds with any resemblance of economics and durability. Likewise, fluorescent lighting was the only feasible way to produce a fixed lighting system to function with the overhead sign and illuminate the sign uniformly.

Recognizing the color retention problems associated with porcelain enamel, particularly along the coast and in industrial atmospheres, new and better materials have been sought on a rather limited basis.



FIGURE 1: Deteriorated Porcelain

In the mid-sixties, polyvinylfluoride film was evaluated and found to be superior to porcelain. Polyvinylfluoride has much better color retention than porcelain enamel, is apparently unaffected by marine and industrial atmospheres, and can be used on aluminum or plywood substrates. Unfortunately, polyvinylfluoride became unavailable except in large rolls and on special order. So the Department was back to where it began -- using porcelain enamel.

The fixed lighting of the sign unit initially appeared excellent since a very pleasing degree of uniform illumination was achieved. But quite rapidly the problems began to show. These problems (short lamp life, reduced lumen output, ballast problems and inaccessibility by being overhead) are maintenance headaches that drastically increase the cost of any maintenance function.

In view of these unfavorable conditions, several of the Districts, Houston Urban Office and Divisions began to seek alternatives in overhead sign background materials and sign lighting units. In early 1975, all efforts in the Department were combined into one single project, 1-18-75-222, to study overhead sign background materials and sign lighting units since the two must function together as a single identity to impart a message of useful information to the motorist. To facilitate this study effort, the research staff was composed of traffic engineers from the field and personnel in the Austin offices that specialize in traffic engineering, signing and illumination. One unspoken ground rule applies to all investigations undertaken and the evaluation of results obtained. That rule is: Personal preferences, beliefs and ideas about how things should be are minimized and are replaced with one objective -- to determine the most economical methods, materials and equipment to obtain an in-place system that is as maintenance-free as possible, and satisfy the needs of the motorist. All systems are evaluated on a cost-per-year basis which includes initial cost and maintenance cost.

With the above in mind, it was decided that all background materials would be evaluated in the field, on test fences, and in the Weatherometer. Sign lighting units would be evaluated by making photometric measurements on a simulated sign (Figure 2) placing on existing overhead sign structures, and evaluating the quality of illumination afforded the sign by actual observation of the research staff members. The results of actual observations would then be matched to photometrics to determine acceptable and nonacceptable photometric characteristics of sign lighting units. Since mercury vapor lighting systems have given the Department the least maintenance problems, the mercury vapor source was selected as the source of sign illumination to study.

With this approach in mind, a screening of coating materials began. Several materials used for other type coatings that were performing satisfactorily were included in the study. Coatings based on the following resins were selected for study: thermal setting polyvinylidene fluoride, air dry polyvinylidene fluoride, thermal setting polyester, vinyl toluene/acrylate copolymer, acrylic, polyurethane and alkyd. In addition, an internally-illuminated sign utilizing polycarbonate face material and high specific intensity reflectorized sheeting legend was included in the study. A high specific intensity reflectorized sheeting background sign was also included.

Signs were fabricated utilizing the various coating materials and were placed on the operating freeway system in Houston. As the individual panels were being made for complete signs, additional

panels were made for fence and accelerated testing. All completed signs, except the internally illuminated and the high specific intensity sheeting signs, utilized removable copy legend and border meeting the requirements of Item 724, "Removable Reflectorized Cutout Letters, Numerals, Arrows, Symbols, Corner Radii for Sign Borders, Broders and Reflectorized Outlines for U.S. and State Route Markers." Approximately two years after the start of the project, four high specific intensity signs were added to the project, Figures 8A and 8B.

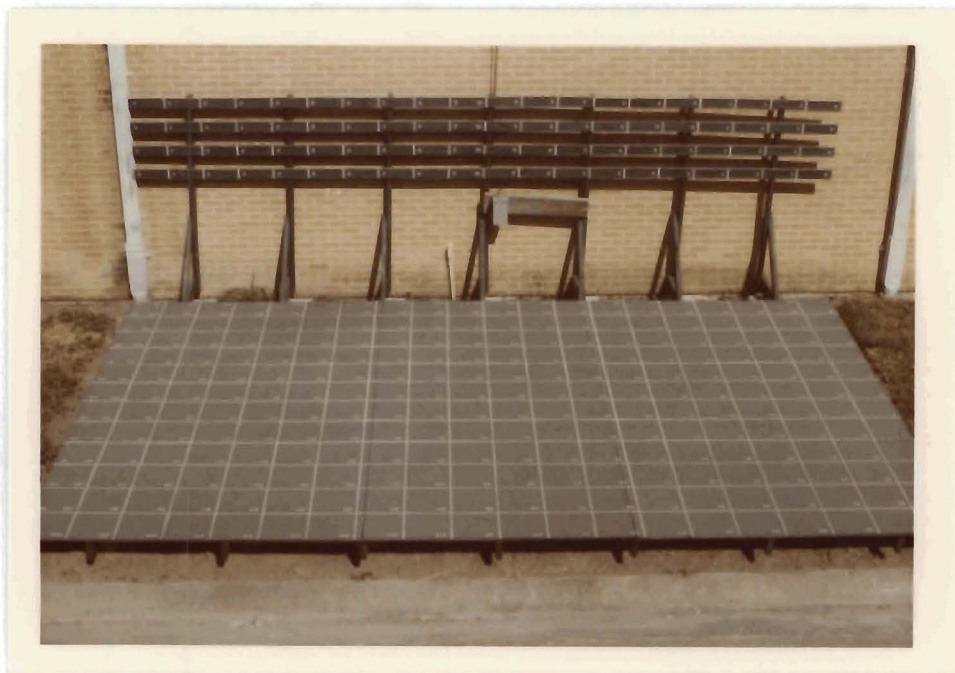

FIGURE 2  
Simulated Sign for Photometric Measurement





FIGURE 3.  
Polyvinylidene Fluoride - Thermal Setting (Pennwalt)



FIGURE 3A.  
Polyvinylidene Fluoride - Thermal Setting (Alcoa-PPG)



FIGURE 3B.  
Polyvinylidene Fluoride - Air Dry (Pennwalt)



FIGURE 4.  
Polyester-Thermal Setting (Bottom Panels Polyurethane)





FIGURE 5.  
Vinyl Toluene/Acrylate Copolymer-Acrylic



FIGURE 6.  
Polyurethane  
on Extruded Aluminum



FIGURE 6A.  
Polyurethane on Medium Density Plywood



FIGURE 7.  
Alkyd



FIGURE 8.  
High Specific Intensity - High Specific Intensity Legend  
and Border - Initial Installation (Aluminum  
Sheet Overlay)



FIGURE 8A.  
High Specific Intensity Sheeting on Aluminum Overlay





FIGURE 8B.

High Specific Intensity Sheeting on High Density Plywood  
Left Sign - Button Removable Copy  
Right Sign - High Specific Intensity Removable Copy

Panels prepared for fence and weatherometer testing were taken to the Materials and Tests Laboratory for testing. After receiving test panels in the laboratory, one panel of each material was numbered and taken to Corpus Christi to be placed on the D-9 test fence at Nueces Bay. The test fence is located to the east side of the Nueces Bay Causeway on U.S. 181, facing southeast into prevailing wind at 45° to horizontal, and the bottom of the fence platform is approximately eight feet above meantide. The prevailing wind at the test fence site comes out of the Gulf of Mexico, across Corpus Christi Bay, and then about 400 yards of land before reaching the test fence. Corrosion data shows this general area to be the most corrosive atmospheric marine environment along the Texas Coast. At periodic intervals, the test panels are evaluated for film and color retention characteristics.



FIGURE 9.  
Test Rack - Nueces Bay

Another panel of each material was cut so that at least two 3 by 9-inch panels were obtained for weatherometer testing. The chromaticity coordinates and brightness of each panel were determined on a Gardner Color Difference Meter before exposing in the weatherometer, and were determined again at various exposure intervals as well as making visual ratings. The weatherometer is an Atlas Sunshine Type fitted with an 18-102 (18 minutes of sunshine and rain, and 102 minutes of sunshine) cyclic gear.

The remaining pieces of the panels from which the weatherometer panels were cut were saved and processed for infrared and X-ray tests. Liquid paint or powdered coating samples were obtained. Infrared and X-ray analysis were made for identification purposes so a very small amount of coating could be removed from a completed sign panel to determine if the coating supplied was the one specified. The test also determines whether a thermosetting coating has been undercured, cured properly or overcured.

Signs utilizing thermal setting polyvinylidene fluoride, thermal setting polyester, polyurethane, vinyl toluene/acrylate copolymer and acrylic, alkyd and the high specific intensity sheeting have been placed on the freeways in Houston. At the beginning of the project, an internally-illuminated sign was placed on the roadway. Due to legibility problems that could not be resolved, the sign was removed from the freeway and from further study on the project.

Panels of thermal setting polyvinylidene fluoride, thermal setting polyester, air dry polyvinylidene fluoride, polyurethane, vinyl toluene/acrylate and acrylic, alkyd and urethane acrylic were exposed on the test fence at Corpus Christi. Some 15 months after placing the panels on the test fence, a weather disturbance destroyed most of the test fence and panels. The test fence was rebuilt and test panels of thermal setting polyester and air dry polyvinylidene fluoride were salvaged and replaced on the test fence. New panels were prepared with the polyurethane, urethane acrylic and air dry polyvinylidene fluoride and placed on the test fence. The new set of test panels were placed on the test fence on November 3, 1976.

After approximately two years on the roadway, 15 months on the test fence, and 600 hours of exposure in the weatherometer, polyvinylidene fluoride and polyester were judged by the committee as having durability and color retention characteristics similar to or better than porcelain enamel, and were therefore suitable for use as overhead sign background coating materials. Since all existing overhead sign specifications utilized basically aluminum and plywood as substrate materials, it was decided to rewrite specifications in such a manner that all acceptable substrates and coatings for overhead signs, as well as all other specifications for overhead signs, would be contained in one specification. The revised specification is in Appendix I. Polyvinylidene and polyester are included in the specification.

At the approximate two-year period when all signs installed on the roadway were evaluated, the committee agreed that the particular location of the high specific intensity sign was not realistic for an accurate, overall evaluation. It was determined that high specific intensity sheeting did not have sufficient retrodirective reflective properties to be of much value to the motorist (specifically target value) when placed in critical maneuvering areas or areas of short sight distance. The committee appraised the situation and decided to place additional high specific intensity signs on the roadway. Locations were selected so that the minimum sight distance would be approximately 1000 feet and all signs would be facing south.

A total of four new high specific intensity signs were made. Two of the signs utilized high density plastic face plywood as background substrate. One of the plywood signs utilized high specific intensity sheeting removable legend and border, and the other utilized removable legend and border meeting requirements for acrylic plastic reflector button legend. The two plywood signs were made complete with all hardware ready to place on existing sign bridges.

The other two high specific intensity signs utilized 0.060 aluminum sheet as substrate. One aluminum sign utilized high specific intensity sheeting legend and border, and the other utilized removable legend and border meeting requirements for acrylic plastic reflector button legend. These two signs were fabricated in panels to be placed as overlays over existing deteriorated porcelain aluminum signs.



When the four high specific intensity signs were erected on the roadway the existing sign illumination was not turned off on the two plywood signs, but was turned off on the two aluminum signs.

Several Districts and the Houston Urban Office have been utilizing 250-watt mercury vapor sign lighting fixtures in recent years with success. Therefore, the initial investigation of sign light fixtures centered around the 250-watt mercury vapor unit. It was noted after testing that the photometric output of all units fell into three categories. The first category was units that exhibited photometric characteristics measured in footcandles, approximately twice the minimum specified in the specification in use for 250-watt units. The second category was units that produced photometrics about one and one-half times the current minimum specified. The third category was units that barely met current minimum requirements.

Projects had been completed utilizing units in all three categories of 250-watt units. These projects were viewed and it was concluded that as a rule signs illuminated with units in category three had good target value and legibility. Signs illuminated with units in categories one and two had excellent target value, but legibility was impaired due to washout caused by high intensities of illumination on the sign face.

The situation was appraised and it was concluded that the wattage could be dropped to 175 watts and still obtain satisfactory results.

Several 175-watt ballasts and lamps were secured and placed in some of the 250-watt units previously tested. Photometrics of the units utilizing the 175-watt ballasts and lamps were determined. All units were then placed on existing overhead sign structures and evaluated. After evaluation, it was concluded that the wattage in the better units (category one) could be reduced to 100 watts.

Several 100-watt ballasts, lamps and units were secured, tested for photometric characteristics, and then placed on existing overhead sign structures. After installation of the 100-watt units, there were systems on the roadway utilizing 250-, 175- and 100-watt mercury vapor clear and color-corrected lamps.

The installed sign lighting systems were individually evaluated by each member of the research committee. To make sure the systems were evaluated as fairly and as impartially as possible, continuous fluorescent and 250-watt clear mercury vapor lighting systems were viewed before, during and after viewing the systems in the research study. To obtain results of the evaluation, each committee member except the two primary researchers voted on each unit under test according to his evaluation of that unit. All members of the committee agreed, by the independent vote process, that certain 100-watt mercury vapor units produced sufficient illumination for good target value, satisfactory uniformity and good legibility. A majority of the committee members felt that the clear lamp gave better overall color rendition and legibility, and preferred the clear lamp use over the color-corrected lamp.

After the visual evaluation of the sign lighting units on the roadway, the units were compared as to photometric data. The photometric data for previously accepted 100-watt units was photometrically evaluated and photometric criteria was generated for specification purposes. Specifications covering 100-watt mercury vapor sign lighting fixtures as developed by the research committee can be found in Appendix I, Specifications Developed.

At the present time, there are six manufacturers that have submitted sign lighting units that will meet the specifications developed. The committee will continue to test and evaluate units already on the roadway and any new units submitted that warrant testing for specification compliance, as well as revise the specification if deemed necessary by the committee.

Included in Appendix II are typical data and photometric isolux curves for 250-, 175- and 100-watt mercury vapor sign lighting fixtures.

The above encompasses all work completed since the project began approximately four years ago. All coating materials and sign lighting fixtures are continuing to be monitored and new coating materials are being sought.

Based on figures obtained from the manufacturers and the Equipment and Procurement Division (File D-4), the table below shows an estimated cost-per-year per-square-foot of sign background coating. The figures do not include substrate cost, but do include application costs.

<u>Material</u>	<u>Expected Life-yrs.*</u>	<u>Cost/ft.<sup>2</sup></u>	
		<u>Initial</u>	<u>Cost/yr.-Life</u>
Engr. Gr. Sheeting	5	\$1.472	\$0.294
H.I. Sheeting	10	\$2.472	\$0.247
Urethane Acrylic	5	\$0.863	\$0.173
PVF <sub>2</sub> , air dry	7**	\$0.612	\$0.087
PVF <sub>2</sub> , thermal	15**	\$0.601	\$0.040
Porcelain	10	\$1.00	\$0.100
Polyester	15**	\$1.00	\$0.067

\*Expected life is determined as the anticipated time when chalking occurs to the point that the sign is unsightly.

\*\*Weatherometer tests indicate that the PVF<sub>2</sub> air dry film may last ten years or more, and the PVF<sub>2</sub> thermal film and polyester may last twenty years or longer.

All cost figures in the above table are based on quotes from producers, except that the two sheeting costs are costs to the Department as of September 1978. Competition could and should shift the other cost data slightly one way or the other, depending on the quantity required on a project or group of projects let at the same time.

APPENDIX I  
Specifications Developed

SPECIAL SPECIFICATION

ITEM 7345

OVERHEAD GUIDE SIGNS

1. Scope. This item shall govern the materials, composition, application, sampling, testing, measurement and payment of substrates, background coatings, and Removable Reflectorized Cutout Letters, Numerals, Arrows, Symbols, Corner Radii for Sign Borders and Borders, Frames, Stiffeners, Windbeams and Joint Backing Strips utilized in the makeup of complete, in place Overhead Guide Signs.
2. Intent. It is the intent of this specification to insure the installation, on the roadway, of aesthetically-legible, Overhead Guide Signs of the quality specified hereinafter.

Specifications, codes, accepted practices, etc., not specifically listed in these specifications are not applicable.

3. Materials Choice. Unless otherwise specified in the plans, the Contractor shall have the option to supply Overhead Guide Signs utilizing substrates and background coatings conforming to the requirements of this specification of his choice, subject to the following restrictions:
  - A. The background coating on all Overhead Guide Signs for any one project shall be of the same generic material except as follows:
    - (1) When one or more substrates (plywood or aluminum) are specified for specific signs, then all signs of each type substrate shall have the same background coating material.
    - (2) When one or more substrates (plywood or aluminum) are specified for specific signs, the Contractor may use a background coating that is compatible with both substrates as shown in Subarticle 3.B. of this specification.
    - (3) When the background color for specific signs restricts the use of materials due to quantities involved, then all such signs shall be of one background coating.

- B. Background coatings shall be utilized only on substrates shown in the following table.

Background Coating

Material

Substrate

Polyvinyl Fluoride  
Plastic Film (PVF)

plywood or aluminum (extruded or sheet)

Polyvinylidene Fluoride  
Plastic (PVF<sub>2</sub> thermosetting)

aluminum (extruded or sheet)

Polyvinylidene Fluoride  
Plastic (PVF<sub>2</sub> Air-dry)

plywood or aluminum (extruded or sheet)

Thermoplastic Polyester

aluminum (extruded or sheet)

Acrylic Polymer Film

plywood or aluminum (extruded or sheet)

Porcelain

aluminum (extruded or sheet)

7345.000

- C. Coatings on removable reflectorized cutout letters, numerals, arrows, symbols, corner radii for sign borders and borders shall be the same generic type coating as used on the background or polyvinylidene fluoride (either thermo-setting or air-dry) except when polyvinylidene fluoride thermosetting is used on the background it shall also be on the text and borders.

The Contractor shall, within 30 days after issuance of work order, submit to the Engineer his option as to choice of substrates and background coatings to be supplied on the project by Type and Class (example: Type 1 Class A would be aluminum extrusion coated with polyvinyl fluoride plastic film).

4. Sign Panel Substrates. Overhead guide sign substrates shall meet the requirements specified below for the various types of substrates. Aluminum for Types 1 & 2 aluminum signs shall conform with the requirements of ASTM Specification B209 alloy 6061 or alloy 6063 for sheet aluminum, ASTM Specification B221 alloy 6061 or alloy 6063 for aluminum extrusions, or similar alloy approved by the Engineer which is suitable for background coating to meet the specifications contained herein. Minimum yield strength of the aluminum shall be 12,000 psi.

Where splicing is required, the splicing shall be done by rivets, bolts, or other fasteners as shown on working drawings furnished by the Contractor, subject to approval by the Engineer. Rivets or other fasteners shall be flush with the face side to provide a smooth, even surface for the application of background coating.

The pieces of substrate used in making the sign shall be fastened to frames, stiffeners, wind beams, or joint backing strips as shown on the plans or on working drawings furnished by the Contractor, subject to approval by the Engineer. Stiffeners, wind beams, joint backing strips, and fasteners shall be stainless steel, galvanized steel, or aluminum, subject to the condition that dissimilar metals shall be selected or insulated to prevent corrosion.

All fabrication of substrates used in making the signs, including cutting and drilling or punching of holes, except holes for attaching removable cutout letters, numerals, arrows, symbols, borders, and corner radii for sign borders, shall be complete prior to degreasing and application of background coating.

- A. Type 1 (Extruded Aluminum). Extruded aluminum sign panels shall have a minimum thickness of 0.109 inch except in the case of 6" panels, 0.080 inch thickness may be used. Panels shall be of a 12-inch width except that one 6-inch width panel per sign may be used to obtain the specified overall sign height. Adjacent panels shall be attached to each other by means of bolts. The normal final background coating color is green but may be other colors as shown in the plans.
- B. Type 2 (Sheet Aluminum). Aluminum Signs (Type 2) are usually, but not restricted to, multi-piece sheet aluminum construction having green background coating on the face side unless otherwise specified in the plans. Sheet aluminum shall be of the thickness shown on the plans.

As nearly as possible, individual pieces of sheet aluminum used in making a sign shall have a width of five (5) feet, and the number of pieces used in making any one sign shall be kept to a practical minimum. Not more than two (2) pieces for any one complete sign may be fabricated to less than five (5) feet in width to obtain a specific overall sign dimension.

Each piece of sheet aluminum shall be flat within measured plus or minus 0.040 inch per foot across the plane of the piece from opposite corners. All edges shall be straight within a tolerance of plus or minus 1/16 inch.

When more than one piece of sheet aluminum is used in making a sign, backing strips shall be used at the joints to keep abutting pieces in proper alignment. Each piece shall be provided with suitable fastenings which are designed to permit easy attachment to and removal from supporting members and which will develop the full strength of the sign.

- C. Type 4 (Plywood). Plywood signs (Type 4) are usually, but not restricted to, multi-piece plywood panel construction and normally have a green background coating on the face side.

Panels shall be four (4) feet by eight (8) feet or smaller and shall be of one piece construction free of either scarf or butt joints. Unless otherwise shown in the plans, no panel shall have a face dimension less than 1' - 6". Number of panels per completed sign shall be kept to a minimum.

The panels shall be of a smooth, weather-resistant material suitable for highway signs produced by permanently bonding high density plastic overlay sheets to both sides of Exterior Grade douglas fir or western larch plywood panels. The high density plastic overlay sheets shall meet the requirements of the latest revision of U.S. Product Standard PS 1 "High Density Type".

The overlay sheets shall have a finished surface that is hard, smooth, unbroken and of such character that further finishing by paint or varnish is not required.

Defects in Veneer, Permits and Bond of Veneers shall be in accordance with the latest revision of U.S. Products Standard PS 1. Neither edge of a panel shall have any core gaps or edge splits in excess of 3/8" wide nor shall the average width exceed 3/16". Core gaps and edge splits per 8 feet of cross band layer shall not exceed four in number.

To be acceptable for sign use, a panel, when placed on a level, plane surface, shall not deviate from the surface more than two inches at any point.

All panels shall be free of dents, bruises, scratches, veneer or overlay delaminations, paint, stains or other damage which would interfere with its use in sign construction.

All panels shall bear legible American Plywood Association (DFPA) grade-markings which shall reflect the following:

Plywood Grade (Ext.)  
Overlay (HDO for High Density Overlay)  
The Inspection Agency (DFPA)  
The Specification (PS 1)  
The Producing-Mill Identification



5. Frames, Stiffeners, Wind Beams, Joint Backing Strips, and Fasteners. Frames, stiffeners, wind beams, joint backing strips and fasteners shall be stainless steel, galvanized steel, or aluminum, subject to the condition that dissimilar metals shall be so selected or insulated as to prevent corrosion.

Unless required otherwise by the plans, stainless steel frames, stiffeners, wind beams, and fasteners shall conform with ASTM Specification A276, Type 302, Annealed, and stainless steel joint backing strips shall conform with ASTM Specification A240, Type 302, Annealed.

Galvanized steel frames, stiffeners, wind beams, joint backing strips, and fasteners shall conform with ASTM Specification A36. Galvanizing shall conform to ASTM Designation: A153, Class A.

Aluminum frames, stiffeners, wind beams, and joint backing strips shall conform to ASTM Specification B308 alloy 6061-T6, ASTM Specification B235 alloy 6061-T6, or ASTM Specification B209 alloy 6061-T6. Aluminum fasteners shall conform with the latest recommendations of the Aluminum Association's Committee on Highway Applications.

6. Background Coating Materials. All overhead guide sign panels shall be coated on the face side with one or more of the background coatings listed below subject to requirements and/or restrictions elsewhere in this specification or as noted on the plans.

Surface preparation of background substrates prior to application of various background coatings shall be as recommended by the manufacturer of the specific coating and approved by the Engineer and/or as specifically noted for specific coatings, hereinafter.

Application of the various coatings to the substrate shall be as per manufacturer's recommendations approved by the Engineer and/or as specified, hereinafter.

- A. Class A Background Coating (Polyvinyl Fluoride Plastic Film PVF). Polyvinyl fluoride plastic film may be applied on all types of substrates listed under Item 4 above and shall meet the following requirements.

The sign panel shall be overlaid with a PVF film a minimum of 0.0015" thick. The PVF film shall be bonded to the sign panel substrate with adhesives and procedures recommended by the film manufacturer.

The top edge of plywood guide sign panels shall be sealed with pressure sensitive film during panel fabrication operation. The long edges and bottom edge of the laminate shall be sealed with a high grade liquid exterior sealer, color matched to the film overlay. All field cut raw edges not protected by acrylic film shall be sealed by a heavy coat of exterior sealer color matched to the film overlay.

B. Class B Background Coating (Polyvinylidene Fluoride Plastic - Thermosetting PVF<sub>2</sub>). Polyvinylidene fluoride plastic - thermosetting (Class B) shall only be applied on aluminum substrates, Types 1 or 2, of Item 4 above and shall meet the requirements therein. Surface preparation, application and applied PVF<sub>2</sub>-thermosetting requirements shall be as specified below.

(1) Surface Treatment. The aluminum surfaces of the sign shall be chemically cleaned prior to application of the coating, free from grease, oil, dirt and excess oxide. The surface preparation shall be according to coating manufacturer's recommendations and approved by the Engineer.

(2) Finish. All aluminum panels shall receive a shop-applied, oven-baked coating based on polyvinylidene fluoride with proper pretreatment and primer. The coating shall be applied to the sign face and outside surfaces of extrusion flanges. The back and/or inside surface of extrusion flanges are not to be coated. Application shall be performed by spray - air or electrostatic. Curing shall be performed in a "continuous or batch" oven according to manufacturer's instructions.

(a) Thickness. The dry film thickness of the coating shall be a minimum of one (1) mil (0.2-0.3 mil primer and 0.8 mils minimum of the top coat). The coating shall be uniform throughout and free of blemishes, blisters, sags or crazing.

C. Class C Background Coating (Polyvinylidene Fluoride Plastic - Air Dry, PVF<sub>2</sub>-AD). Polyvinylidene fluoride plastic - air dry (Class C) may be applied to all background substrates shown in Item 4 above and shall meet the following requirements.

(1) Surface Preparation. Aluminum surfaces shall be prepared as specified in 6.B.(1) above for Class B Background Coating or other surface preparation recommended by the coating manufacturer and approved by the Engineer. Surface preparation of plywood surfaces shall be by solvent washing with methyl-ethyl-ketone, methyl-isobutyl-ketone or a mixture of the two. In addition to solvent washing, the plywood surface shall be further prepared by the application of a primer, tie-coat and/or intermediate coat, when recommended by the coating manufacturer, prior to application of the final color coat.

(2) Finish. All sign panels shall receive a shop-applied, air-dry coating based on polyvinylidene fluoride with proper surface preparation and pretreatment. The coating shall be applied to the face side only, except that edges of plywood and outside faces of extrusion flanges shall be coated also. Application shall be by spray only - air, airless or electrostatic. Curing shall be by air drying and/or low temperature oven baking according to the coating manufacturer's recommendations.

(a) Thickness. The dry film thickness of any primer, tie-coat or intermediate coat recommended by the coating manufacturer shall be as recommended. The dry film thickness of the final color coat shall be a minimum of 1.0 mil.

D. Class D Background Coating (Thermoplastic Polyester). Thermoplastic polyester (Class D) shall be applied on only aluminum substrates Types 1 or 2 of Item 4 above and shall meet the following requirements.

(1) Surface Treatment. The aluminum surfaces to which the coating is to be applied shall be free from grease, oil, dirt and excess oxide, and be chemically cleaned prior to application of the coating.

(2) Finish. All aluminum panels shall receive a shop-applied, oven-baked coating based on Thermoplastic Polyester with proper pretreatment and primer (when recommended by coating manufacturer). The coating shall be applied to the sign face and outside surfaces of extrusion flanges. The back and/or inside surfaces of the extrusion flanges are not to be coated. Application shall be performed by spray - air, airless or electrostatic. Curing shall be performed in a "continuous or batch" oven according to coating manufacturer's recommendations and at no time shall it exceed 700°F.

(a) The dry film thickness of the finish coating shall be a minimum of 0.004 inch and a maximum of 0.012 inch. The coating shall be uniform throughout and free of blemishes, blisters, pinholes, cracks, sags or crazing.

E. Class E Background Coating (Acrylic Polymer Film). Acrylic polymer film Class E may be applied to all substrates listed in Item 4 above and shall meet the following requirements.

(1) Surface Treatment. The face side of sign panels shall be cleaned and prepared for the application of the acrylic polymer film according to the film manufacturer's recommendations. The face side of aluminum extrusion flanges shall be cleaned and prepared in the same manner as the sign panel face.

(2) Application. The acrylic polymer film shall be a minimum of 0.003 inch thick and be bonded to the substrate with adhesives and procedures recommended by the film manufacturer.

The acrylic polymer film shall be applied to the face only of aluminum sheet substrates.

The acrylic polymer film shall be applied to the face and a minimum of 1/2 of the outside face of aluminum extrusion flanges.

The top edge of plywood panels shall be sealed with pressure sensitive film during panel fabrication operations. The long edges and bottom edge of the laminate shall be sealed with a high-grade liquid exterior sealer, color matched film overlay.

The acrylic polymer film may be factory overlaid or vacuum overlaid by the sign panel fabricator.

F. Class F Background Coating (Porcelain Enamel). Porcelain enamel Class F may be applied to aluminum substrates listed in Item 4 (Types 1 and 2) above, and shall meet the following requirements.

(1) Surface Preparation. Before the porcelain enameling process, panels shall be given a suitable surface preparation as described in the Porcelain Enamel Institute Bulletin AL-2A, 4th Edition, Section II, "Surface Preparation".

(2) Application of Porcelain Enamel to Face and Edges of Extruded Aluminum Sign Panels. Porcelain enamel shall be so applied to the face side and to the edges of the panels that no aluminum is visible. The thickness of the porcelain enamel application shall be between 0.0015 and 0.007 inch. There shall be no tooling marks on the face side of the panel.

Adherence will be checked on samples selected as outlined in State Department of Highways and Public Transportation MANUAL OF TESTING PROCEDURES. Porcelain enamel aluminum sign faces shall be uniformly finished and free from surface defects. Blemishes which are not visible from a distance of fifty feet when viewed at eye level with the sign surface shall be acceptable.

After porcelain enameling is completed, the extruded aluminum sign panel faces shall be flat and true within a tolerance of one-fourth inch per eight (8) feet of panel length. Flatness along the narrow axis of the panel on the sign face side shall be limited to 0.005 inch per inch of width.

(3) Requirements. Porcelain enamel shall conform with Specifications for Porcelain Enamel on Aluminum as used for Signs and Architectural Applications, Porcelain Enamel Institute Designation ALS-105(57), except that paragraph (e) of Part 2 "Requirements" of ALS-105(57) is deleted and replaced by the following requirement: "The porcelain enamel shall have a weight loss of no more than 20 mg/sq.in. in the boiling acid test, when tested according to ASTM C282."

7. Background Coatings, Applied Film Characteristics: Background Coatings of Classes A, B, C, D and E shall meet the following requirements after the coatings have been applied to the Background Substrate.

In addition to the following requirements, the infrared spectra and X-ray diffraction pattern of Background Coatings of Classes A, B, C, D and E shall match the infrared spectra and X-ray diffraction pattern on file at the Materials and Tests Division of the State Department of Highways and Public Transportation.

A. The applied films, when subjected to the following tests, shall exhibit no loss of bond strength, blistering, checking, crazing or other film appearance and/or adhesion defects.

<u>Test</u>	<u>Exposure Time</u>
Boiling Water Immersion	100 hrs.
Fog Chamber (100°F & 100T R.H.)	12 wks.
Atlas XWR Weatherometer (18-102 cyclic gear)	3,000 hrs.

B. Adhesion. There will be no removal of the finish when tested as follows:

"Using a sharp knife, make six (6) or more parallel cuts at 1/8 inch intervals through finish to bare metal. Cross hatch similarly. Apply Scotch cellophane tape firmly to scribed area. Pull tape off with a sharp jerk. No loss of adhesion shall be experienced."

C. Pencil Hardness. The applied coating shall have a pencil hardness of F minimum.

8. Background Coating Color and Gloss. All background coatings (Classes A, B, C, D, E, and F) shall meet the following color and gloss requirements as set forth for each color; green and white. Any noticeable difference in shades of color or gloss on any one sign panel or between adjacent panels shall be cause for rejection.

A. Green. The color of the finished panel shall be uniform and shall conform with the Standard Interstate Green Color Card as shown in the U.S. Department of Transportation, Federal Highway Administration's "Manual on Uniform Traffic Control Devices for Streets and Highways" (latest edition), and any subsequent applicable Interpretation Memorandum or approved change which pertains to this Manual.

The chromaticity coordinates x and y, and the luminous direction reflection Y, shall meet the following requirements:

$$\begin{aligned} x &= 0.25 \pm 0.02 \\ y &= 0.38 \pm 0.03 \\ Y &= 0.07 \pm 0.02 \end{aligned}$$

Test for color shall be run according to Federal Methods of Tests TT-T-141, Method 4252, using a standard green panel, SGR-30, supplied by the National Bureau of Standards.

The finished panel shall have a gloss reading of a maximum of 60 units at an angle of 45 degrees, according to Federal Methods of Tests TT-T-141, Method 6121.

B. White. The color of the background coating shall be uniformly white and its C.I.E. Chromaticity coordinate limits when determined in accordance with Federal Methods of Tests TT-T-141, Method 4252, shall fall within a rectangle having the following corner points:

1		2		3		4		Reflectance Limit
x	y	x	y	x	y	x	y	
.315	.330	.322	.325	.312	.310	.305	.315	70 Minimum

The applied coating shall have a gloss reading between 50 and 70 units at an angle of 45 degrees when tested according to Federal Methods of Tests TT-T-141, Method 6121.

9. Sign Messages and Borders. The sign messages and borders shall be of the size, type and color shown on the plans.

Reflectorized Removable Copy sign messages and borders specified on the plans for various signs shall conform with Item 724, "Removable Reflectorized Cutout Letters, Numerals, Arrows, Symbols, Corner Radii for Sign Borders, Borders and Reflectorized Outlines for U.S. and State Route Markers."

When Interstate Route Markers and U.S. and State Route Markers are required as a part of the sign message, they shall be reflectorized and shall conform with the plans in size and shape and with the Item, "Aluminum Signs Type A", latest revision of Special Specification thereto.

Interstate, U.S. and State Route Markers shall be attached to Guide signs as shown on the plans by screws or bolts of stainless steel, galvanized steel, or aluminum, subject to the condition that dissimilar metals shall be so selected or insulated to prevent corrosion.

Stainless-steel screws, washers, lock washers, and other hardware shall conform with ASTM Specification A320, Grade B8F, Annealed.

Galvanized steel screws, washers, lock washers, and other hardware shall conform to ASTM Designation: A153, Class C or D.

Aluminum screws, washers, lock washers, and other hardware shall conform with the latest current recommendations of the Aluminum Association's Committee on Highway Applications.

When required by the plans, aluminum hardware used for signs located in coastal and heavy industrial atmospheres shall be given a dichromate sealed finish conforming with the requirements of Specification MIL-A-8625A, Type II.

10. Sign Support Connections and Hardware. Sign support connections shall be as shown on the plans or of the Contractor's choice, subject to approval by the Engineer.

All sign support connections shall be capable of developing the full strength of the sign; and they shall be stainless steel, galvanized steel, or aluminum, subject to the condition that dissimilar metals shall be so selected or insulated to prevent corrosion.

All bolts, nuts, washers, lock washers, and other hardware used in making the signs which are not specifically covered on the plans shall be galvanized steel, stainless steel or aluminum, subject to the condition that dissimilar metals shall be so selected or insulated to prevent corrosion.

Stainless steel sign post or support connections, bolts, nuts, washers, lock washers, and other hardware used in making the signs shall conform with ASTM Specification A 320-58T, Grade B8F, Annealed.

Galvanized steel sign post or support connections, bolts, nuts, washers, lock washers, and other hardware used in making the signs shall conform with ASTM Specification A307. Galvanizing of posts and support connections shall be in accordance with ASTM Designation: A153, Class A. Galvanizing of bolts, nuts, washers, lock washers and other hardware shall conform with ASTM Designation: A153, Class C or D.

Aluminum sign post or support connections, bolts, nuts, washers, lock washers, and other hardware used in making the signs shall conform with ASTM Specification B316 alloy 2024-T4 or of the manufacturer's recommended alloys, subject to approval by the Engineer.

When required by the plans, aluminum sign post or support connections and other aluminum hardware used for signs located in coastal and heavy industrial atmospheres shall be given a dichromate-sealed finish conforming with the requirements of Specification MIL-A-8625A, Type II.

11. Construction Methods. The Contractor shall submit for approval of the Engineer six prints of the working drawings for each sign using Removable Reflectorized Cutout Letters, Numerals, Arrows, Symbols, Corner Radii for Sign Borders and Borders, except that when there are two or more signs of identical design, a working drawing for only one of the signs need be submitted. The working drawings shall show the details of the panels, frames, wind beams, stiffeners, joint backing plates, splices, fasteners, brackets, sign post or support connections, dichromate-sealed finish for aluminum hardware where required by the plans, and methods of attaching removable cutout copy messages to the sign face. The splice bars and windbeams shall be similar to details shown for roadside plywood guide signs. In addition, the working drawing shall show interline spacing of the message in sufficient detail to check against the plans. Accompanying the working drawings, when extrusions are used, the Contractor shall submit the following: The Manufacturer's name, the extrusion number, a dimensional cross section of the panel, and the Manufacturer's calculated moment of inertia and section moduli for each type of extruded panel the Contractor proposes to use.

Completed sign blanks and panels shall be handled and stored in such a manner that corners, edges and faces are not damaged. Any mars, scratches or other damage to the sign faces which are not visible when viewed as outlined in the Manual of Testing Procedures at a distance of fifty feet, shall be acceptable. Finished sign faces shall be stored off the ground in a vertical position and protected from the weather until properly erected.

Sign faces are not acceptable if the variation of the surface in any direction exceeds an amount equal to 1/8 inch per foot of defect of width or height as one case may be. Any vertical or horizontal misalignment between panels greater than 1/8 inch is not acceptable. Misalignment between panel faces shall not be greater than 1/16 inch.

Prior to erection, all bolt heads and hardware showing on sign faces shall be painted similar in color to the sign face.

12. Cleaning. After the signs have been erected, they shall be washed with a cleaning solution approved by the sign panel coating manufacturer to remove all grease, oil, dirt, smears, streaks, finger marks and other foreign particles.

13. Sampling and Testing. Sampling and testing will be in accordance with the State Department of Highways and Public Transportation MANUAL OF TESTING PROCEDURES, unless otherwise specified herein.
14. Measurement. Overhead Guide Signs shall be measured by the square foot. Measurement shall be made to the nearest 0.25 square foot of the area of the vertical front face of the signs erected as determined from the plans and specifications, with no deductions for rounding off corners, and no measurement will be made for area in excess of this minimum area.

Interstate, U.S. and State Route Markers required by the plans and specifications to be part of the message on Overhead Guide Signs will be considered as subsidiary items and shall not be measured.

15. Payment. Payment for Overhead Guide Signs will be made at the unit price bid per square foot for Overhead Guide Signs which price shall be full compensation for furnishing sign panels; fabrication of the panels, any treatment of sign panels that might be required prior to application of the background coating; application of the background coating to the sign panels, furnishing and attaching to the sign faces all Removable Reflectorized Cutout Letters, Numerals, Arrows, Symbols, Corner Radii for Sign Border and Borders, Interstate Route Markers, U.S. Route Markers and State Route Markers; furnishing and fabrication of frames, windbeams, stiffeners, and/or joint backing strips that are required; furnishing all bolts, rivets, screws, fasteners, clamps, brackets and sign support connections; assembling and erecting the signs; washing and cleaning the signs after erection; and all other labor, materials and incidentals necessary to provide signs complete and attached to the sign supports.





## SPECIAL SPECIFICATION

ITEM 7342

### ALUMINUM SIGNS (TYPE M)

1. DEFINITION: Aluminum Signs Type M are signs made from extruded aluminum panels and having the sign face coated with polyvinylidene fluoride plastic.
2. MATERIALS:

Sign Blanks. Extruded aluminum sign panels shall have a minimum thickness of 0.109 inch except in the case of 6" panels a 0.080" thickness may be used. The panels shall conform to the requirements of ASTM Specification B221 alloy 6061 or alloy 6063 for aluminum extrusions, or similar alloy approved by the Engineer which is suitable for background coating to meet the specifications contained herein. Minimum yield strength of the aluminum shall be 12,000 psi.

Panels shall be of a 12-inch width except that one 6-inch width panel may be used in any one sign where necessary to obtain a specified overall sign height. Adjacent panels shall be attached to each other by means of bolts.

Extruded aluminum sign panels that require splicing shall be spliced by rivets, bolts or other fasteners as shown on working drawings furnished by the Contractor, subject to approval by the Engineer. All splices shall be capable of developing the full strength of the section. Rivets or other fasteners shall be flush with the face side to provide an even surface for the application of polyvinylidene fluoride. The aluminum panels shall be fastened to frames, stiffeners, wind beams, or joint backing strips as shown on the plans or on working drawings furnished by the Contractor, subject to approval by the Engineer. All fabrication of sign panels including cutting and drilling or punching of holes, except mounting holes for removable cutout letters, numerals, arrows, symbols and borders shall be completed prior to metal degreasing and application of polyvinylidene fluoride.

Frames, stiffeners, wind beams, joint backing strips and fasteners shall be stainless steel, galvanized steel, or aluminum subject to the condition that dissimilar metals shall be so selected or insulated as to prevent corrosion.

Unless required otherwise by the plans, stainless steel frames, stiffeners, wind beams and fasteners shall conform with ASTM Specification A276, Type 302, Annealed, and stainless steel joint backing strips shall conform with ASTM Specification A240, Type 302, Annealed.

Galvanized steel frames, stiffeners, wind beams, joint backing strips and fasteners shall conform with ASTM Specification A36. Galvanizing shall be in accordance with the Item, "Metal for Structures", of the Standard Specifications.

Aluminum frames, stiffeners, wind beams and joint backing strips shall conform with the requirements of ASTM Specification B308 alloy 6061-T6, ASTM Specification B235 alloy 6061-T6, or ASTM Specification B209 alloy 6061-T6. Aluminum fasteners shall conform with the latest current recommendations of the Aluminum Association's Committee on Highway Applications.

## 2.2 Coating Treatment.

A. Surface Treatment. The aluminum surfaces of the sign shall be chemically cleaned prior to application of the coating, free from grease, oil, dirt and excess oxide. The surface preparation shall be according to coating manufacturer recommendations and approved by the Engineer.

B. Finish. All aluminum panels shall receive a shop-applied, oven-baked coating based on polyvinylidene fluoride with proper pretreatment and primer. The coating shall be applied to the sign face and outside surfaces of extrusion flanges. The back and/or inside surface of extrusion flanges are not to be coated. Application shall be performed by spray - air or electrostatic. Curing shall be performed in a "continuous or batch" oven according to manufacturer's instructions.

1. Thickness. The dry film thickness of the coating shall be a minimum of one (1) mil (0.2 - 0.3 mil primer and 0.8 mils minimum of the top coat). The coating shall be uniform throughout and free of blemishes, blisters, sags or crazing.

### C. Requirements.

In addition to the following requirements, the infrared spectra and x-ray diffraction pattern of Background Coatings of Classes A, B, C, D and E shall match the infrared spectra and x-ray diffraction pattern on file at the Materials and Tests Division of the State Department of Highways and Public Transportation.

1. The applied films, when subjected to the following tests, shall exhibit no loss of bond strength, blistering, checking, crazing or other film appearance and/or adhesion defects.

<u>Test</u>	<u>Exposure Time</u>
Boiling Water Immersion	100 hrs.
Fog Chamber (100°F & 100% R.H.)	12 wks.
Atlas XWR Weatherometer (18-102 cyclic gear)	3,000 hrs.

2. Adhesion. There shall be no removal of the finish when tested as follows:

"Using a sharp knife, make six (6) or more parallel cuts at 1/8-inch intervals through finish to bare metal. Cross-hatch similarly. Apply Scotch cellophane tape firmly to scribed area. Pull tape off with a sharp jerk. No loss of adhesion shall be experienced."

3. Pencil Hardness. The applied coating shall have a pencil hardness of F minimum.

4. Finish Color. The color of the finished panel shall be uniform and shall conform with the Standard Interstate Green Color Card as shown in the U.S. Department of Transportation, Federal Highway Administration's "Manual on Uniform Traffic Control Devices for Streets and Highways" (latest edition), and any subsequent applicable Interpretation Memorandum or approved change which pertains to this Manual.

The chromaticity coordinates x and y, and the luminous direction reflection Y, shall meet the following requirements:

$$\begin{aligned}x &= 0.25 \pm 0.02 \\y &= 0.38 \pm 0.03 \\Y &= 0.07 \pm 0.02\end{aligned}$$

Test for color shall be run according to Federal Methods of Tests TT-T-141, Method 4252, using a standard green panel (SGR-30) supplied by the National Bureau of Standards.

The finished panel shall have a gloss reading of a maximum of 60 units at an angle of 45 degrees, according to Federal Methods of Tests TT-T-141, Method 6121.

5. Visual. The coating on all surfaces exposed to weathering shall be free of blemishes and/or failure(s) in the coating that may impair the serviceability or detract from the general appearance and color matching of the sign when viewed from a distance of fifty (50) feet. Identification of such blemishes or failures shall be cause for immediate rejection. Repair or replacement of any signs or coated extrusions failing to meet the visual inspection shall be done to the satisfaction of the Engineer, at the Contractor's expense.

2.3 Sign Support Connections and Hardware. Sign Support connections for signs made from extruded aluminum panels shall be as shown on the plans or of the supplier's choice, subject to approval by the Engineer. The connections shall have no fasteners which project through the front face of the panel; they shall be capable of developing the full strength of the panel; and they shall be stainless steel, galvanized steel, or aluminum, subject to the condition that dissimilar metals shall be so selected or insulated as to prevent corrosion.

All bolts, nuts, washers, lock washers, and other hardware used in making the signs which are not specifically covered on the plans shall be galvanized steel, stainless steel, or aluminum, subject to the condition that dissimilar metals shall be so selected or insulated as to prevent corrosion.

Stainless steel sign support connections, bolts, nuts, washers, lock washers, and other hardware used in making the signs shall conform with ASTM Specification A320, Grade B8F, Annealed.

Galvanized steel sign support connections, bolts, nuts, washers, lock washers, and other hardware used in making the signs shall conform with ASTM Specification A307. Galvanizing shall be in accordance with the Item, "Metal for Structures", of the Standard Specifications.

Aluminum sign support connections, bolts, nuts, washers, lock washers, and other hardware used in making the signs shall conform with the latest current recommendations of the Aluminum Association's Committee on Highway Applications.

When required by the plans, aluminum sign support connections and other aluminum hardware used for signs located in coastal and heavy industrial atmospheres shall be given a dichromate sealed finish conforming with the requirements of Specification MIL-A8625A, Type II.

2.4 Sign Messages and Borders. The sign messages and borders shall be of the size, type and color shown on the plans for the various signs and shall conform with the applicable specification(s).

When Interstate, US and State Route Markers are required as a part of the sign message, they shall be reflectorized and shall conform with the plans and with the Item, "Aluminum Signs (Type A)".

3. WORKING DRAWINGS. The Contractor shall submit for approval of the Engineer seven prints of the working drawings for each sign, except that when there are two or more signs of identical design, a working drawing for only one of the signs need be submitted. The working drawings shall show the details of the panels, frames, wind beams, stiffeners, joint backing plates, splicers, if any, fasteners, brackets, sign support connections, and methods of attaching removable cutout copy messages to the sign face. In addition, the working drawings shall show letter and interline spacing of the message in sufficient detail to check against the plans.

Accompanying the working drawings, the Contractor shall submit the following: The Manufacturer's name, the extrusion number, a dimensional cross section of the panel, and the Manufacturer's calculated moment of inertia and section moduli for each type of extruded panel the Contractor proposes to use.

4. CLEANING. After the signs have been erected, they shall be washed with a cleaning solution approved by the sign panel coating manufacturer to remove all grease, oil, dirt, smears, streaks, finger marks and other foreign particles.
5. SAMPLING AND TESTING. Sampling and testing will be in accordance with the State Department of Highways and Public Transportation's Manual of Testing Procedures, unless otherwise specified herein.
6. MEASUREMENT. Aluminum Signs (Type M) shall be measured by the square foot. Measurement shall be made to the nearest 0.25 square foot of the area of the vertical front face of the signs erected as determined from the plans and specifications, with no deductions for rounding off corners, and no measurement will be made for area in excess of this minimum area.
7. PAYMENT. Payment for Aluminum Signs (Type M) will be made at the unit price bid per square foot for "Aluminum Signs (Type M)", which price shall be full compensation for furnishing extruded aluminum sign panels; fabrication of the panels; any treatment of sign panels that might be required prior to the application of polyvinylidene fluoride; application of polyvinylidene fluoride to the sign panels; furnishing and attaching to the sign faces all removable reflectorized cutout letters, numerals, arrows, symbols, borders, and corner radii for sign borders as shown on the plans; furnishing and fabrication of frames, wind beams, stiffeners, and/or joint backing strips that are required; and sign support connections; assembling and erecting the signs; washing and cleaning the signs after erection; and all other labor, materials and incidentals necessary to provide signs complete and attached to the sign supports.



SPECIAL SPECIFICATION

ITEM 7343

ALUMINUM SIGNS  
(TYPE N)

1. DEFINITION: Aluminum Signs Type N are signs made from extruded aluminum panels and having the sign face coated with thermoplastic polyester.
2. MATERIALS:

Sign Blanks. Extruded aluminum sign panels shall have a minimum thickness of 0.109 inch except in the case of 6" panels a 0.080" thickness may be used. The panels shall conform to the requirements of ASTM Specification B221 alloy 6061 or alloy 6063 for aluminum extrusions, or similar alloy approved by the Engineer which is suitable for background coating to meet the specifications contained herein. Minimum yield strength of the aluminum shall be 12,000 psi.

Panels shall be of a 12-inch width except that one 6-inch width panel may be used in any one sign where necessary to obtain a specified overall sign height. Adjacent panels shall be attached to each other by means of bolts.

Extruded aluminum sign panels that require splicing shall be spliced by rivets, bolts or other fasteners as shown on working drawings furnished by the Contractor, subject to approval by the Engineer. All splices shall be capable of developing the full strength of the section. Rivets or other fasteners shall be flush with the face side to provide an even surface for the application of thermoplastic polyester. Aluminum panels shall be fastened to frames, stiffeners, wind beams, or joint backing strips as shown on the plans or on working drawings furnished by the Contractor, subject to approval by the Engineer. All fabrication of sign panels including cutting and drilling or punching of holes, except mounting holes for removable cutout letters, numerals, arrows, symbols and borders shall be completed prior to metal degreasing and application of thermoplastic polyester.

Frames, stiffeners, wind beams, joint backing strips and fasteners shall be stainless steel, galvanized steel, or aluminum subject to the condition that dissimilar metals shall be so selected or insulated as to prevent corrosion.

Unless required otherwise by the plans, stainless steel frames, stiffeners, wind beams and fasteners shall conform with ASTM Specification A276, Type 302, Annealed, and stainless steel joint backing strips shall conform with ASTM Specification A240, Type 302, Annealed.



Galvanized steel frames, stiffeners, wind beams, joint backing strips, and fasteners shall conform with ASTM Specification A36. Galvanizing shall be in accordance with the Item, "Metal for Structures", of the Standard Specifications.

Aluminum frames, stiffeners, wind beams and joint backing strips shall conform with the requirements of ASTM Specification B308 alloy 6061-T6, ASTM Specification B235 alloy 6061-T6, or ASTM Specification B209 alloy 6061-T6. Aluminum fasteners shall conform with the latest current recommendations of the Aluminum Association's Committee on Highway Applications.

## 2 Coating Treatment.

A. Surface Treatment. The aluminum surfaces to which the coating is to be applied shall be free from grease, oil, dirt and excess oxide, and be chemically cleaned prior to application of the coating.

B. Finish. All aluminum panels shall receive a shop-applied, oven-baked coating based on thermoplastic polyester with proper pretreatment and primer (when recommended by coating manufacturer). The coating shall be applied to the sign face and outside surfaces of extrusion flanges. The back and/or inside surfaces of the extrusion flanges are not to be coated. Application shall be performed by spray - air, airless or electrostatic. Curing shall be performed in a "continuous or batch" oven according to coating manufacturer's recommendations and at no time shall it exceed 700°F.

1. Thickness. The dry film thickness of the finish coating shall be a minimum of 0.004 inch and a maximum of 0.012 inch. The coating shall be uniform throughout and free of blemishes, blisters, pin-holes, cracks, sags or crazing.

C. Requirements. In addition to the following requirements, the infrared diffraction pattern of Background Coatings of Classes A, B, C, D and E shall match the infrared spectra and x-ray diffraction pattern on file at the Materials and Tests Division of the State Department of Highways and Public Transportation.

1. The applied films, when subjected to the following tests, shall exhibit no loss of bond strength, blistering, checking, crazing or other film appearance and/or adhesion defects.

<u>Test</u>	<u>Exposure Time</u>
Boiling Water Immersion	100 hrs.
Fog Chamber (100°F & 100% R.H.)	12 wks.
Atlas XWR Weatherometer (18-102 cyclic gear)	3,000 hrs.

2. Adhesion. There shall be no removal of the finish when tested as follows:

"Using a sharp knife, make six (6) or more parallel cuts at 1/8-inch intervals through finish to bare metal. Cross-hatch similarly. Apply Scotch cellophane tape firmly to scribed area. Pull tape off with a sharp jerk. No loss of adhesion shall be experienced."

3. Pencil Hardness. The applied coating shall have a pencil hardness of F minimum.

4. Finish Color. The color of the finished panel shall be uniform and shall conform with the Standard Interstate Green Color Card as shown in the U.S. Department of Transportation, Federal Highway Administration's "Manual on Uniform Traffic Control Devices for Streets and Highways" (latest edition), and any subsequent applicable Interpretation Memorandum or approved change which pertains to this Manual.

The chromaticity coordinates x and y, and the luminous direction reflection Y, shall meet the following requirements:

$$\begin{aligned}x &= 0.25 \pm 0.02 \\y &= 0.38 \pm 0.03 \\Y &= 0.07 \pm 0.02\end{aligned}$$

Test for color shall be run according to Federal Methods of Tests TT-T-141, Method 4252, using a standard green panel (SGR-30) supplied by the National Bureau of Standards.

The finished panel shall have a gloss reading of a maximum of 60 units at an angle of 45 degrees, according to Federal Methods of Tests TT-T-141, Method 6121.

5. Visual. The coating on all surfaces exposed to weathering shall be free of blemishes and/or failure(s) in the coating that may impair the serviceability or detract from the general appearance and color matching of the sign when viewed from a distance of fifty (50) feet. Identification of such blemishes or failures shall be cause for immediate rejection. Repair or replacement of any signs or coated extrusions failing to meet the visual inspection shall be done to the satisfaction of the Engineer, at the Contractor's expense.

3 Sign Support Connections and Hardware. Sign support connections for signs made from extruded aluminum panels shall be as shown on the plans or of the supplier's choice, subject to approval by the Engineer. The connections shall have no fasteners which project through the front face of the panel; they shall be capable of developing the full strength of the panel; and they shall be stainless steel, galvanized steel, or aluminum, subject to the condition that dissimilar metals shall be so selected or insulated as to prevent corrosion.

All bolts, nuts, washers, lock washers, and other hardware used in making the signs which are not specifically covered on the plans shall be galvanized steel, stainless steel, or aluminum, subject to the condition that dissimilar metals shall be so selected or insulated as to prevent corrosion.

Stainless steel sign support connections, bolts, nuts, washers, lock washers, and other hardware used in making the signs shall conform with ASTM Specification A320, Grade B8F, Annealed.

Galvanized steel sign support connections, bolts, nuts, washers, lock washers, and other hardware used in making the signs shall conform with ASTM Specification A307. Galvanizing shall be in accordance with the Item, "Metal for Structures", of the Standard Specifications.

Aluminum sign support connections, bolts, nuts, washers, lock washers, and other hardware used in making the signs shall conform with the latest current recommendations of the Aluminum Association's Committee on Highway Applications.

When required by the plans, aluminum sign support connections and other aluminum hardware used for signs located in coastal and heavy industrial atmospheres shall be given a dichromate sealed finish conforming with the requirements of Specification MIL-A8625A, Type II.

2.4 Sign Messages and Borders. The sign messages and borders shall be of the size, type and color shown on the plans for the various signs and shall conform with the applicable specification(s).

When Interstate, US and State Route Markers are required as a part of the sign message, they shall be reflectorized and shall conform with the plans and with the Item, "Aluminum Signs (Type A)".

3. WORKING DRAWINGS. The Contractor shall submit for approval of the Engineer seven prints of the working drawings for each sign, except that when there are two or more signs of identical design, a working drawing for only one of the signs need be submitted. The working drawings shall show the details of the panels, frames, wind beams, stiffeners, joint backing plates, splicers, if any, fasteners, brackets, sign support connections, and methods of attaching removable cutout copy messages to the sign face. In addition, the working drawings shall show letter and interline spacing of the message in sufficient detail to check against the plans.

Accompanying the working drawings, the Contractor shall submit the following: The Manufacturer's name, the extrusion number, a dimensional cross section of the panel, and the Manufacturer's calculated moment of inertia and section moduli for each type of extruded panel the Contractor proposes to use.

4. CLEANING. After the signs have been erected, they shall be washed with a cleaning solution approved by the sign panel coating manufacturer to remove all grease, oil, dirt, smears, streaks, finger marks and other foreign particles.
5. SAMPLING AND TESTING. Sampling and testing will be in accordance with the State Department of Highways and Public Transportation's Manual of Testing Procedures, unless otherwise specified herein.
6. MEASUREMENT. Aluminum Signs (Type N) shall be measured by the square foot. Measurement shall be made to the nearest 0.25 square foot of the area of the vertical front face of the signs erected as determined from the plans and specifications, with no deductions for rounding off corners, and no measurement will be made for area in excess of this minimum area.
7. PAYMENT. Payment for Aluminum Signs (Type N) will be made at the unit price bid per square foot for "Aluminum Signs (Type N)", which price shall be full compensation for furnishing extruded aluminum sign panels; fabrication of the panels; any treatment of sign panels that might be required prior to the application of thermoplastic polyester; application of thermoplastic polyester to the sign panels; furnishing and attaching to the sign faces all removable reflectorized cutout letters, numerals, arrows, symbols, borders, and corner radii for sign borders as shown on the plans; furnishing and fabrication of frames, wind beams, stiffeners, and/or joint backing strips that are required; and sign support connections; assembling and erecting the signs; washing and cleaning the signs after erection; and all other labor, materials and incidentals necessary to provide signs complete and attached to the sign supports.



SPECIAL PROVISION

TO

ITEM 724

REMOVABLE REFLECTORIZED CUTOUT LETTERS,  
NUMERALS, ARROWS, SYMBOLS, CORNER RADII  
FOR SIGN BORDERS, BORDERS AND REFLECTORIZED OUTLINES  
FOR U.S. AND STATE ROUTE MARKERS

For this project, Item 724, "Removable ReflectORIZED Cutout Letters, Numerals, Arrows, Symbols, Corner Radii for Sign Borders, Borders and ReflectORIZED Outlines for U.S. and State Route Markers", of the Standard Specifications, is hereby amended with respect to the clauses cited below and no other clauses or requirements of this item are waived or changed hereby.

Section 724.2. Materials. (2) Finishing is hereby voided and replaced by the following:

- (2) Finishing. After metal fabrication has been completed, the aluminum frames shall be finished in white or black as required by the plans. The finish coating may be either Polyvinylidene Fluoride Plastic-Thermosetting or Thermosetting Polyester and shall meet the following requirements. In addition to the following requirements, the infrared spectra and the X-ray diffraction pattern of the applied coatings shall match the infrared spectra and X-ray diffraction pattern on file at the Materials and Tests Division of the State Department of Highways and Public Transportation.
- (a) General. The aluminum surfaces shall be chemically cleaned prior to application of the coating and free from grease, oil, dirt and excess oxide. The surface preparation shall be according to the coating manufacturer's recommendations and approved by the Engineer. Coating shall be applied by spray or dipping so as to form a smooth film of uniform thickness and free of any and all types of defects. Curing shall be by "continuous or batch" oven according to manufacturer's recommendations.
- (b) Polyvinylidene Fluoride Plastic-Thermosetting: The dry film thickness of the polyvinylidene fluoride-plastic film shall be a minimum of one (1) mil (0.2 - 0.3 mils of primer and 0.8 mils minimum of top coat).
- (c) Thermoplastic Polyester: The dry film thickness of the thermoplastic polyester film shall be a minimum of four (4) mils and a maximum of twelve (12) mils.

(d) Applied Film Characteristics: The coating films shall meet the following requirements after the coatings have been applied to the aluminum frames and properly cured.

1. When subjected to the following tests, the applied films shall exhibit no loss of bond strength, blistering, checking, crazing or other film appearance and/or adhesion defects.

<u>Test</u>	<u>Exposure Time</u>
Boiling Water Immersion	100 hrs.
Fog Chamber (100°F & 100% R.H.)	12 wks.
Atlax XWR Weatherometer (18-102 cyclic gear)	3000 hrs.

2. Adhesion: There will be no removal of the finish when tested as follows:

"Using a sharp knife, make six (6) or more parallel cuts at 1/8 inch intervals through finish to bare metal. Cross-hatch similarly. Apply Scotch cellophane tape firmly to scribed area. Pull tape off with a sharp jerk. No loss of adhesion shall be experienced."

3. Pencil Hardness: The applied coating shall have a pencil hardness of F minimum.
4. Color and Gloss: The applied coatings shall meet the following color and gloss requirements as set forth for each color; white and black. Any noticeable difference in shades of color or gloss on any one symbol or between adjacent symbols at 25 feet shall be cause for rejection.

- a. White: The color of the applied coating shall be uniformly white and its C.I.E. Chromaticity coordinate limits, when determined in accordance with Federal Methods of Tests TT-T-141, Method 4252, shall fall with a rectangle having the following corner points:

1		2		3		4	
x	y	x	y	x	y	x	y
.315	.330	.322	.325	.312	.310	.305	.315

Reflectance Limit shall be 70 minimum. The applied coating shall have a gloss reading between 50 and 70 units at an angle of 45 degrees, when tested according to Federal Methods of Tests TT-T-141, Method 6121.

- b. Black: The color of the applied coating shall be uniformly black and shall have a gloss reading between 50 and 70 units at an angle of 45 degrees when tested according to Federal Methods of Tests TT-T-141, Method 6121.



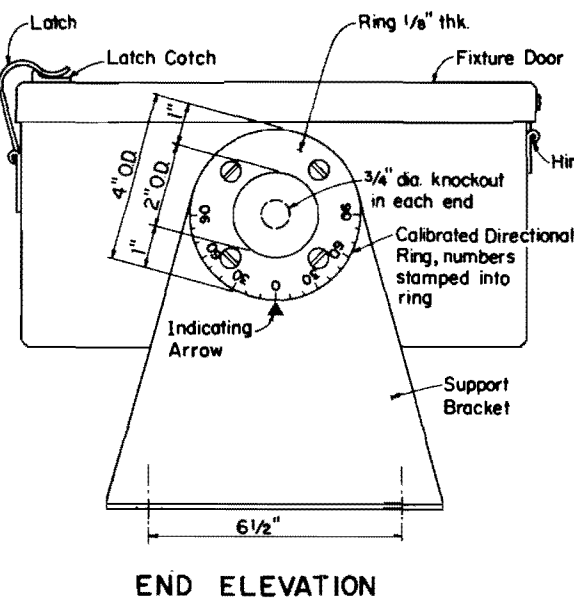
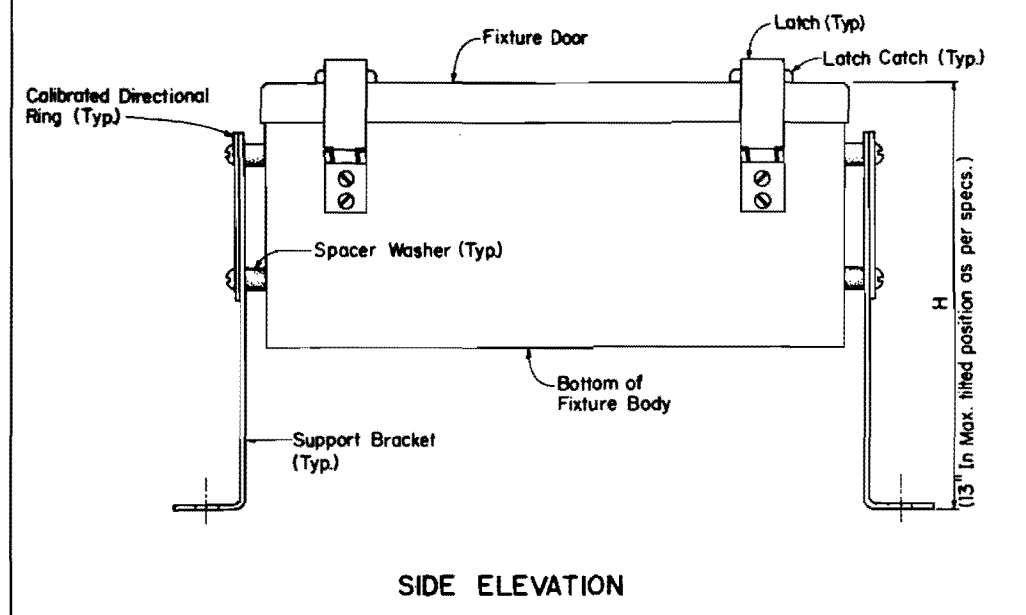
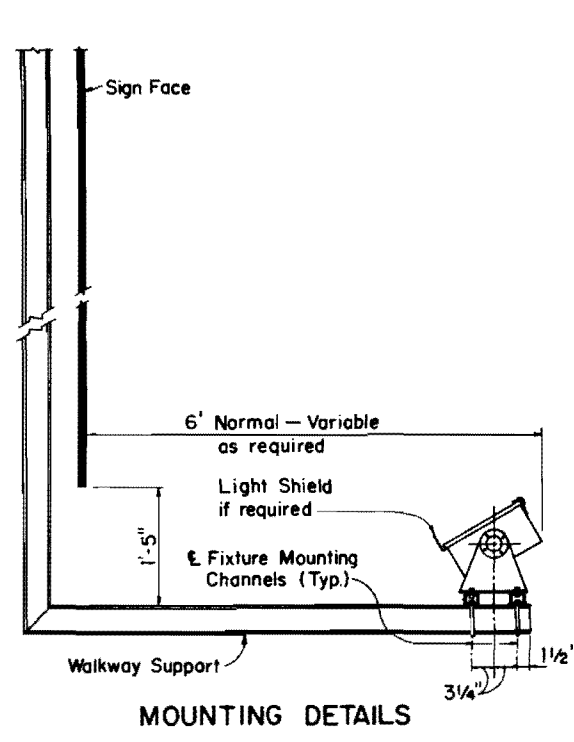
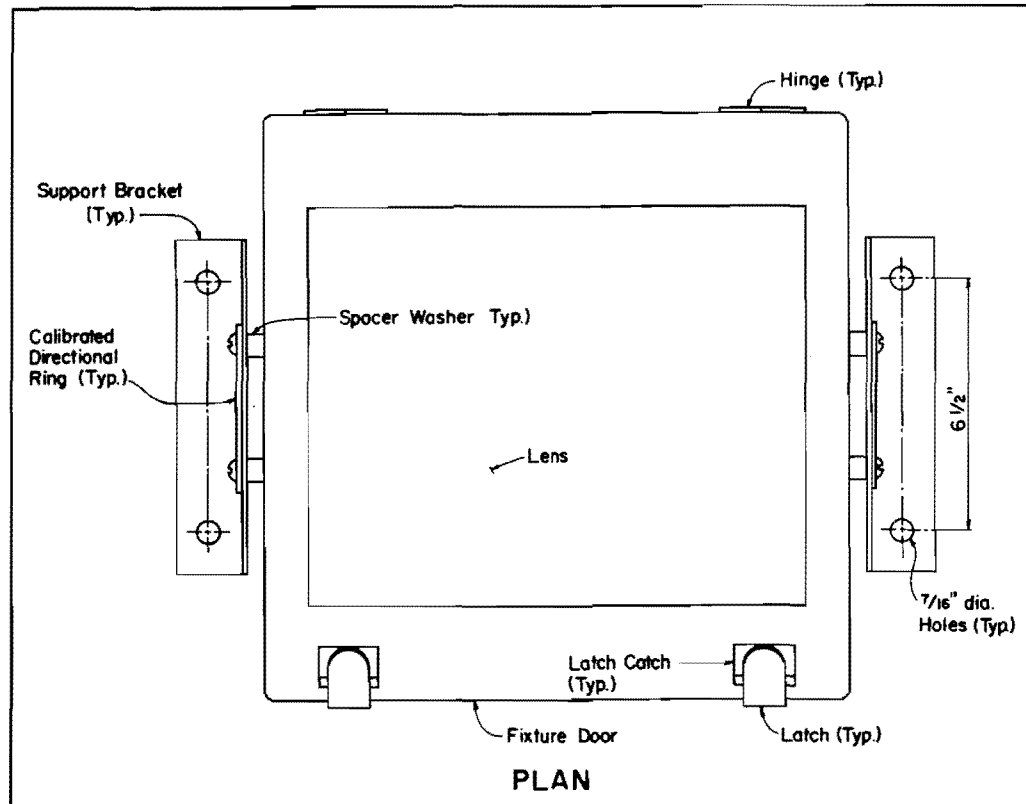

**GENERAL NOTES AND SPECIFICATIONS**

Fixtures may be constructed of either aluminum, galvanized steel, or other approved weather-resistant materials and so constructed as to form a weather-tight unit of sufficient strength to withstand normal installation and maintenance operations.

The fixture shall not exceed 2.0 square feet in projected area, nor exceed 35.0 pounds in gross weight, including ballast. The fixture shall provide aiming provisions that are continuously variable through all angles for 30 degrees on each side of the optimum aiming angle. Aiming shall be marked in 10 degree increments. Provisions shall be incorporated to positively lock the sign-light fixture in the desired position. Mounting provisions shall rigidly support the fixture and be compatible with mounting requirements as set forth in the plans. When aimed at any of the required variable angles, above a plane passing through and parallel to the base of the mounting, the overall height of the fixture above this plane shall not exceed 13 inches.

The optic assembly shall be constructed in such a manner that resilient gaskets are incorporated to maintain a positive seal against weather and other contaminants. The lens of the optic assembly shall be tempered glass. The cover to the optic assembly may be opened for routine maintenance without the use of tools. A keeper shall be provided to prevent unintentional separation of the cover from the fixture housing. The metal socket shall incorporate a means to positively resist lamp removal and be attached to a high grade porcelain base that completely encases the metal shell. The socket shall be Underwriter's Laboratory approved.

The fixture may be internally or externally ballasted with a regulated output-type ballast designed to operate mercury vapor lamps. External ballast shall be in weatherproof encasement. During fluctuation of the primary voltage to the ballast up to ±13% of the center-rated voltage, the input wattage to the ballast shall not vary more than 8%, nor exceed 150% of the lamp-rated wattage. At center-rated voltage, the power factor shall not be less than 90%. Each ballast shall permanently and clearly indicate the following: Type Ballast, Type Lamp, Catalog Number, Voltage Rating, and Wiring Diagram (when stick-on or glue-on label is used, permanency will be considered satisfactory provided no more than 25% of the label can be removed in one piece). Ballast shall be individually fused with easily accessible in-line 10 amp fuses. Lamps shall be 100-watt (or other wattage as specified in the plans), clear mercury vapor with a rated average life of not less than 24,000 hours.

The Department will bear the cost of testing all materials meeting the requirements of this drawing and the specifications. The Contractor will bear the cost of testing all materials failing to meet the requirements. Cost for testing failing materials will be deducted from amounts due the Contractor on Monthly and Final Estimates.

The 100-watt sign-lighting fixture (when mounted vertically five feet above, and horizontally one foot below, the midpoint of either short side of a horizontal rectangular area measuring eight feet by ten feet, with the fixture facing the center of the opposite short side, and when aimed at optimum angle [note below]) shall provide measured intensities of not less than 3.0 nor greater than 50 footcandles on any point within the previously defined rectangular area. Measured intensities on the surface of the previously defined rectangular area shall not increase at a rate greater than 2.6 in any one foot interval. Note: Optimum angle is that angle which produces equal measured intensities, in footcandles, on all four corners of the eight foot by ten foot rectangular area described. Sign-lighting fixtures of wattages other than 100-watt shall meet the photometric requirements stated above when mounted, with respect to the sign, as shown in the plans.

All wired joints within fixture shall be waterproofed. All electrical components furnished and installed shall be in compliance with National Electrical Code Specifications. All Mercury Vapor Sign Lighting Fixtures that are to be mounted on Bridge Mounted Sign Structures shall be equipped with Vandal Guards as approved by the Engineer. Vandal Guards shall not be paid for directly but shall be considered incidental to "Merc Vap Sign Light Fixt". Deflectors shall be installed on Sign Lighting fixtures to prevent glare to the oncoming motorists. Deflector shall be as approved by the Engineer.

The Supplier shall state the Optimum Angle or the indicator mark shall be centered on 0 at the Optimum Angle. Sampling and testing shall be in accordance with the Department's "Manual of Testing Procedures". The fixture will be tested using a lamp furnished for the same project. The manufacturer shall submit a prototype fixture to the Engineer for approval before placement. An adequate number of sign lighting fixtures received for the project may be selected at random by the Department and tested to assure conformity with the specifications. It is not intended that the sign lighting fixtures will be damaged by the test procedures. All fixtures will be inspected and evaluated after energized and adjusted to determine final acceptance of the units.

Fixture Mounting Channels shall be continuous for entire length of walkway and shall be the same distance from the truss for the entire length of the channels. The lighting unit shown is an example only and is not intended to specify a certain manufacturer's product. Other comparable commercial designs which meet the requirements of the specifications, and as approved by the Engineer, will be accepted.

**STATE DEPARTMENT OF HIGHWAYS AND PUBLIC TRANSPORTATION**

**MERCURY VAPOR SIGN LIGHTING FIXTURE**

SL(MV)

ORIGINAL DRAWING DATE: 1-78		STATE DISTRICT	FEDERAL REGION	FEDERAL AID PROJECT	SHEET
DESIGNED BY: H.V.J.	REVISIONS				
CHECKED BY: M.V.J.					
DATE: T.S.B.		COUNTY	CONTRACT NUMBER	JOB NUMBER	
CHECKED BY: J.B.S.					

APPENDIX II  
Photometric Data

ROW LINE	A	B	C	D	E	F	G	H	J	K	L	M	N
21	.85	.91	.94	.98	1.08	1.04	.96	.89	.80	.73	.60	.34	.19
20	1.04	1.13	1.17	1.31	1.39	1.46	1.38	1.43	1.23	1.19	.89	.52	.27
19	1.24	1.43	1.5	1.71	1.7	2.0	2.0	2.2	1.9	2.1	1.91	1.25	.43
18	1.51	1.70	1.87	2.1	2.4	2.6	2.7	2.9	3.1	3.0	3.3	3.1	.81
17	1.67	1.99	2.2	2.6	3.0	3.4	3.5	4.0	4.5	4.7	5.5	5.6	1.8
16	1.8	2.2	2.5	3.0	3.5	4.3	4.7	5.4	5.6	6.4	6.9	7.1	3.2
15	1.9	2.3	2.7	3.3	4.1	4.9	5.6	6.8	7.4	7.9	7.4	6.8	3.7
14	1.9	2.3	2.7	3.4	4.2	5.2	6.1	7.4	8.1	9.3	8.9	7.9	4.2
13	1.9	2.3	2.8	3.5	4.4	5.4	6.4	8.0	9.3	10.5	10.0	9.0	5.2
12	1.9	2.3	2.7	3.5	4.4	5.4	6.4	8.0	9.6	10.8	10.3	9.8	6.5
11	1.9	2.3	2.7	3.5	4.4	5.4	6.4	8.1	9.6	11.3	11.4	10.5	7.0
10	2.0	2.4	2.9	3.7	4.8	5.6	6.7	8.3	10.1	11.5	11.6	10.5	5.1
9	2.1	2.6	3.1	3.9	4.8	6.0	7.3	8.9	10.9	12.2	11.9	10.2	6.0
8	2.1	2.7	3.1	3.8	4.9	6.3	7.5	9.0	10.5	12.1	11.1	9.0	5.1
7	2.1	2.7	3.1	3.8	4.8	5.8	7.0	8.6	9.8	10.2	9.7	7.8	4.7
6	2.0	2.5	2.9	3.5	4.4	5.3	6.1	7.2	7.8	8.0	8.2	8.1	3.4
5	1.92	2.3	2.6	3.2	3.7	4.2	4.7	5.7	6.0	5.6	5.6	5.9	2.0
4	1.65	2.0	2.2	2.6	2.8	3.1	3.4	4.0	3.9	3.6	3.6	3.1	1.01
3	1.35	1.57	1.67	1.9	2.1	2.3	2.4	2.6	2.3	2.1	1.88	1.54	.48
2	1.06	1.17	1.28	1.41	1.54	1.64	1.56	1.55	1.25	12.0	1.02	.70	.30
1	.82	.93	1.05	1.15	1.30	1.26	1.20	1.04	.93	.81	.68	.44	.22

TABLE I  
SIGN LIGHT #2  
100-watt Mercury Vapor Color Corrected Lamp  
5 Feet Above Sign Face  
Centered Above 11-N

100 WATT MERCURY VAPOR COLOR CORRECTED LAMP

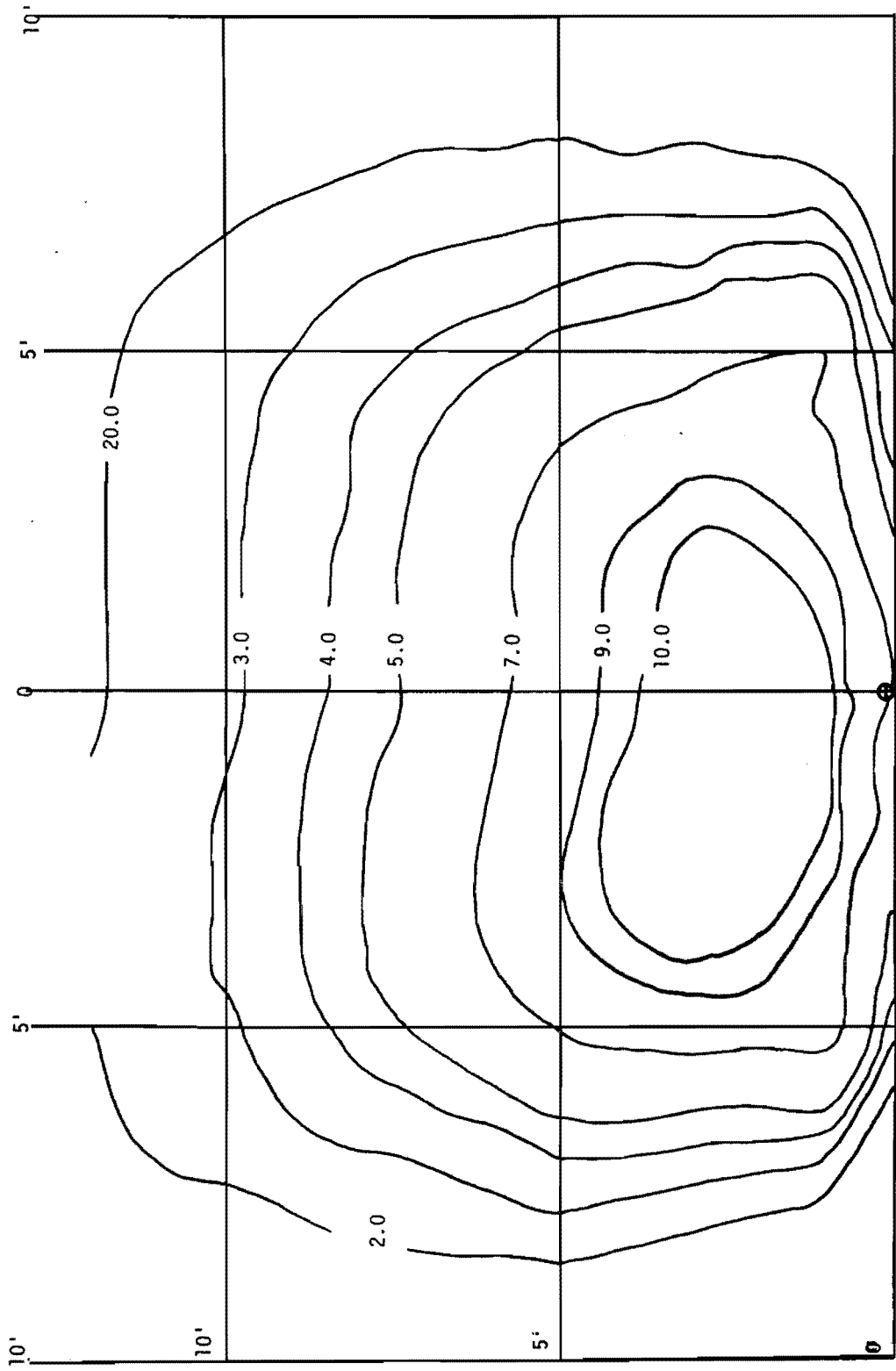

ROW LINE	A	B	C	D	E	F	G	H	J	K	L	M	N
1	2.6	3.2	2.9	3.1	2.4	2.8	2.6	2.6	2.3	2.0	1.3	0.74	0.36
2	3.3	4.2	3.8	4.3	3.7	3.9	3.2	3.4	4.2	2.8	1.7	1.05	0.50
3	3.9	5.0	5.2	6.4	5.3	6.0	4.8	5.0	4.2	4.3	3.0	1.97	0.78
4	4.0	5.6	5.9	7.9	6.7	8.7	7.6	7.6	6.4	6.4	5.1	3.3	1.28
5	4.4	6.1	6.4	8.7	9.0	12.1	11.6	12.0	10.5	10.1	8.8	6.2	2.5
6	5.0	6.5	6.7	8.9	11.3	13.4	14.5	17.2	16.3	17	13.7	12.2	5.2
7	6.2	7.7	7.6	9.5	12.0	13.8	15.0	19.0	22	24	23	20	12.1
8	6.7	9.0	9.2	10.8	12.0	14.2	15.3	20	22	28	32	33	26
9	6.8	8.4	9.4	11.8	12.7	15	15.9	21	26	30	38	52	44
10	6.1	7.2	8.1	10.3	12.4	14.3	15.8	19.9	26	33	43	63	60
11	5.9	7.0	7.7	9.8	11.5	13.8	15.5	19.6	24	33	47	64	58
12	7.0	8.1	8.7	11.2	12.7	14.6	15.3	18.0	21	25	29	45	51
13	7.6	8.4	9.0	10.8	11.6	12.5	12.8	15.1	18.6	23	34	45	40
14	5.7	6.7	6.9	8.1	9.0	10.8	12.8	15.9	19.6	25	30	29	21
15	4.7	5.5	6.0	7.3	9.2	11.2	13.6	16.1	21	21	21	17.8	10.9
16	4.2	5.0	5.8	7.3	9.5	11.2	13.0	14.0	14	14.0	13.0	9.8	5.1
17	4.1	5.0	5.9	7.3	9.2	10.1	10.4	10.0	9.7	8.5	7.6	5.5	2.4
18	4.3	4.8	5.7	6.6	7.7	7.3	6.8	6.5	6.3	5.3	4.7	2.8	1.3
19	3.9	4.6	5.0	5.1	5.4	5.0	4.7	4.1	4.3	3.5	2.7	1.57	0.85
20	3.7	3.8	4.0	3.8	3.8	3.3	3.2	2.9	2.9	2.4	1.6	0.95	0.53
21	3.1	2.7	3.0	2.6	2.4	2.4	2.4	2.2	2.2	1.6	1.16	0.68	0.41

TABLE 2  
SIGN LIGHT #19  
175-watt Mercury Vapor Color Corrected Lamp  
5 Feet Above Sign Face  
Centered Above 11-N

175 WATT MERCURY VAPOR COLOR CORRECTED LAMP

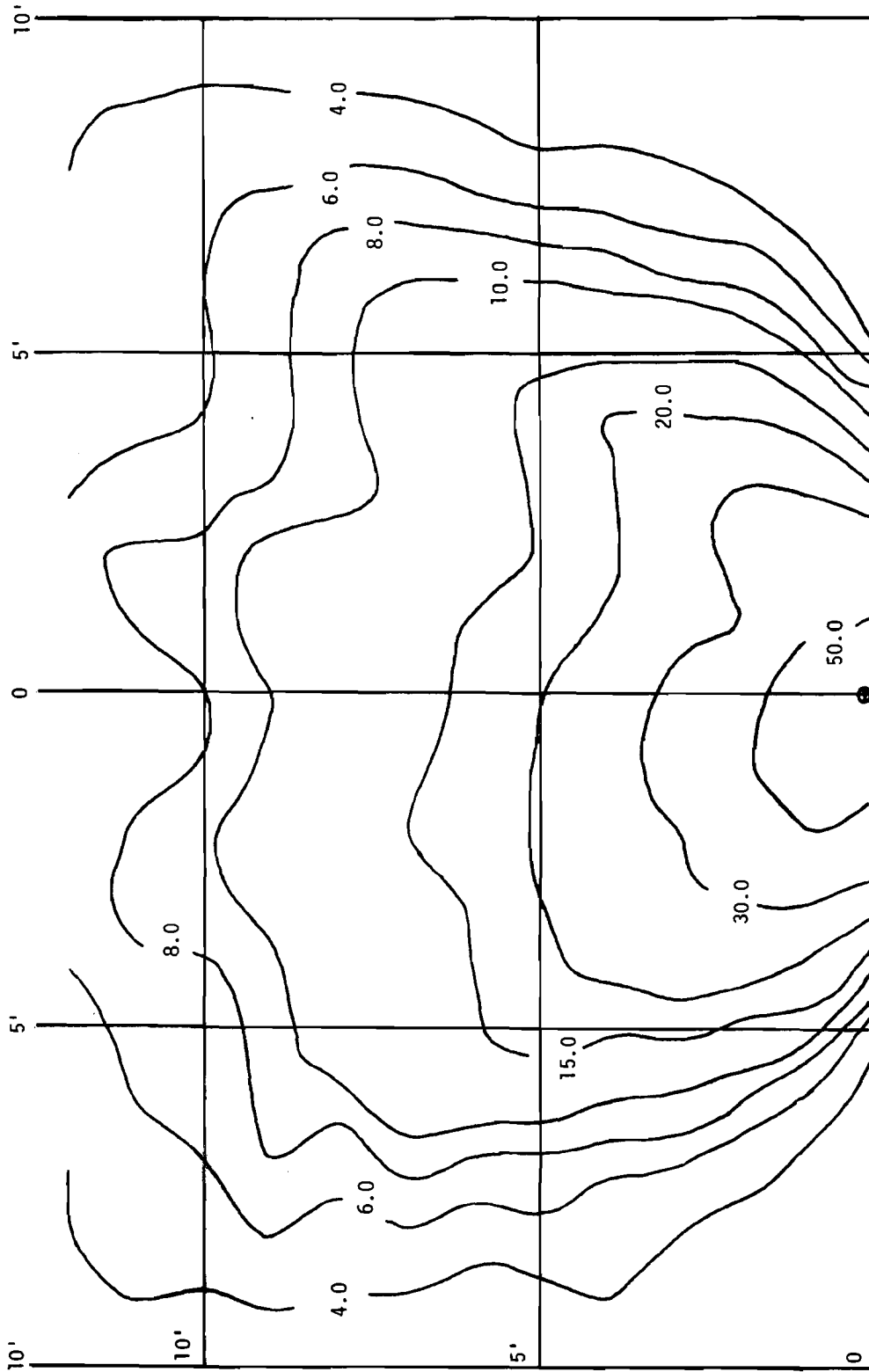

ROW LINE	A	B	C	D	E	F	G	H	J	K	L	M	N
21	2.9	3.0	3.2	3.4	3.4	3.4	3.1	2.6	2.2	2.0	1.63	1.17	.64
20	3.5	3.7	4.1	4.0	4.7	4.7	4.6	4.0	3.3	2.8	2.3	1.56	.84
19	4.0	4.4	5.1	5.7	6.1	6.8	6.7	6.7	5.3	4.6	3.4	2.3	1.23
18	5.0	5.5	6.5	7.5	8.8	9.5	10.7	11.2	10.2	8.5	7.2	5.0	2.0
17	5.6	6.3	7.7	9.0	10.5	12.6	14.5	15.8	16.1	14.9	12.7	10.6	4.7
16	6.5	7.4	9.3	11.5	14.5	16.6	20.0	23.0	27.0	26.0	23.0	19.0	9.9
15	7.1	8.0	10.8	12.0	16.5	18.8	24.0	29.0	38.0	36.0	35.0	27.0	17.9
14	7.3	8.6	10.9	14.0	18.2	22.0	27.0	32.0	42.0	49.0	50.0	45.0	24.0
13	7.8	8.5	11.2	14.3	19.4	23.0	30.0	38.0	51.0	57.0	66.0	60.0	35.0
12	8.0	9.2	11.5	15.2	22.0	26.0	34.0	41.0	55.0	65.0	74.0	68.0	46.0
11	8.1	9.1	11.3	14.7	18.5	25.0	32.0	41.0	51.0	64.0	77.0	72.0	56.0
10	7.8	9.1	11.9	14.7	21.0	25.0	33.0	41.0	53.0	64.0	71.0	67.0	46.0
9	7.9	8.8	11.2	14.5	19.6	24.0	31.0	40.0	55.0	61.0	68.0	59.0	30.0
8	7.2	8.9	11.2	14.0	18.3	23.0	29.9	35.0	43.0	48.0	48.0	38.0	21.0
7	7.1	8.2	9.9	12.4	14.3	19.4	24.0	29.0	31.0	34.0	33.0	26.0	14.1
6	6.4	7.5	8.9	11.1	15.7	15.9	18.3	20.0	23.0	22.0	9.3	16.5	8.2
5	5.5	6.5	7.7	9.2	11.8	12.2	13.1	13.8	14.0	12.8	11.0	9.1	3.2
4	4.7	5.2	6.2	7.0	8.1	8.6	9.0	9.2	8.4	7.0	5.7	3.7	1.46
3	3.8	4.2	4.6	5.2	5.0	6.0	6.3	6.0	5.1	4.1	3.3	2.1	.80
2	2.8	3.2	3.5	3.9	4.5	4.3	4.0	3.5	2.9	2.4	1.88	1.20	.58
1	2.2	2.4	2.7	3.0	3.1	3.2	2.9	2.5	2.0	1.80	1.36	.93	.45

TABLE 3  
SIGN LIGHT #6  
250-watt Mercury Vapor Color Corrected Lamp  
5 Feet Above Sign Face  
Centered Above 11-N

250 WATT MERCURY VAPOR COLOR CORRECTED LAMP

