

1. Report No. FHWA/TX-96/1943-2		2. Government Accession No.		3. Recipient's Catalog No.	
4. Title and Subtitle AN EVALUATION OF THE USE AND EFFECTIVENESS OF TEMPORARY SEDIMENT CONTROLS				5. Report Date March 1996	
				6. Performing Organization Code	
7. Author(s) M. E. Barrett, J. E. Kearney, T. G. McCoy, J. F. Malina, R. J. Charbeneau				8. Performing Organization Report No. Research Report 1943-2	
9. Performing Organization Name and Address Center for Transportation Research The University of Texas at Austin 3208 Red River, Suite 200 Austin, Texas 78705-2650				10. Work Unit No. (TRAVIS)	
				11. Contract or Grant No. Research Study 7-1943	
12. Sponsoring Agency Name and Address Texas Department of Transportation Research and Technology Transfer Office P. O. Box 5080 Austin, Texas 78763-5080				13. Type of Report and Period Covered Interim	
				14. Sponsoring Agency Code	
15. Supplementary Notes Study conducted in cooperation with the Texas Department of Transportation. Research study title: "Water Quantity and Quality Impacts Assessment of Highway Construction in the Austin, Texas, Area"					
16. Abstract An inventory of temporary runoff controls installed on TxDOT construction sites indicated that rock berms and silt fences were the most commonly used erosion and sediment controls on construction sites. Sediment ponds, the most inexpensive control on a cost-per-area basis, were used more frequently in the earlier stages of construction. Erosion control blankets, the most expensive controls, tended to be used in the later phases of construction. A field evaluation of the efficiency of silt fences in removing sediment carried in runoff from highway construction sites showed that sediment was removed by settling rather than by filtration. Geotextile silt fences proved to be ineffective in reducing turbidity. Monitoring of a single rock berm showed negligible suspended solids removal. High sediment removal efficiencies were achieved with silt fences in flume studies. Mean sediment removal efficiency in the flume was highly correlated with the detention time of the runoff. The flow rates of sediment-laden runoff through the control sections were two orders of magnitude less than those typically specified by transportation agencies. The flow rate of a sediment slurry through geotextile fences was a function of apparent opening size as well as of permittivity. Flow rates through rock berms greatly exceeded the rates typically recommended in guidelines issued by regulatory agencies. The short detention times and large pore size of the berms resulted in only a slight reduction in the suspended solids load.					
17. Key Words Sediment control, geotextile fabric, silt fences, temporary runoff control devices, pollution			18. Distribution Statement No restrictions. This document is available to the public through the National Technical Information Service, Springfield, Virginia 22161.		
19. Security Classif. (of this report) Unclassified		20. Security Classif. (of this page) Unclassified		21. No. of Pages 149	22. Price

**AN EVALUATION OF THE USE AND EFFECTIVENESS OF TEMPORARY
SEDIMENT CONTROLS**

by

Michael E. Barrett
John Edmund Kearney
Terry Glen McCoy
Joseph F. Malina, Jr.
Randall J. Charbeneau

Research Report Number 1943-2

Research Project 7-1943
Water Quantity and Quality Impacts Assessment of Highway Construction
in the Austin, Texas, Area

conducted for the

Texas Department of Transportation

by the

CENTER FOR TRANSPORTATION RESEARCH
Bureau of Engineering Research
THE UNIVERSITY OF TEXAS AT AUSTIN

March 1996

IMPLEMENTATION STATEMENT

The data collected during this study can be used to select the most cost-effective method for control of sediment at highway construction sites. The expected sediment removal efficiency of each type of temporary control can be estimated based on the results of this research effort. The information can also be used to better specify the types of geotextile fabrics that are appropriate for silt fences, and to develop rational guidelines for the placement and installation of temporary controls. The results of the study should assist the Texas Department of Transportation in its preparation of applications for NPDES permits and Water Pollution Abatement Plans.

Prepared in cooperation with the Texas Department of Transportation.

DISCLAIMERS

The contents of this report reflect the views of the authors, who are responsible for the facts and the accuracy of the data presented herein. The contents do not necessarily reflect the official views or policies of the Texas Department of Transportation. This report does not constitute a standard, specification, or regulation.

**NOT INTENDED FOR CONSTRUCTION,
BIDDING, OR PERMIT PURPOSES**

Joseph F. Malina, P.E. (Texas No. 30998)
Research Supervisor

TABLE OF CONTENTS

IMPLEMENTATION STATEMENT	iii
SUMMARY	vii
1.0 INTRODUCTION	1
2.0 LITERATURE REVIEW	5
2.1 Introduction	5
2.2 Sediment Removal Mechanisms	5
2.3 System Performance Factors	6
2.4 Silt Fences	7
2.4.1 Geotextile Fabric	9
2.4.2 Geotextile Characterization	10
2.4.3 Previous Silt Fence Research	11
2.5 Rock Berms	15
2.6 Summary	16
3.0 INVENTORY OF TEMPORARY CONTROL DEVICES	19
3.1 Methodology	19
3.2 Inventory Results	21
4.0 FIELD MONITORING OF TEMPORARY CONTROLS	25
4.1 Introduction	25
4.2 Field Performance of Silt Fences	25
4.2.1 Sample Collection	26
4.2.2 Sample Analysis	27
4.2.3 TSS Reduction Efficiency of Silt Fences	27
4.2.4 Turbidity Reduction of Silt Fences	30
4.2.5 Observations of Silt Fence Performance	30
4.3 Field Monitoring of a Rock Berm	31
4.3.1 TSS Reduction Efficiency of Rock Berms	32
5.0 LABORATORY TESTS OF SILT FENCES AND A ROCK BERM	35

5.1	Flume Tests	35
5.1.1	Flume and Bulk Water Delivery System.....	35
5.1.2	The Soil and Suspended Solids Slurry	37
5.1.3	Sampling and Monitoring	39
5.1.4	Base Efficiency of Testing Apparatus.....	40
5.1.5	Description of Tested Controls	41
5.1.6	Hydraulic Behavior of Sediment Controls in the Flume.....	42
5.1.7	Determining Detention Times for Flume Tests.....	44
5.1.8	TSS Removal Efficiency	45
5.1.9	Effects of Sediment Clogging and Rainfall Washing	47
5.2	Permeameter Tests	48
5.2.1	Methodology.....	48
5.2.2	Results of Permeameter Tests.....	50
6.0	CONCLUSIONS	53
	BIBLIOGRAPHY	57
	APPENDIX A: Sample Descriptions and Locations.....	61
	APPENDIX B: Results of Sample Analyses	85
	APPENDIX C: Laboratory Procedures	95
	APPENDIX D: Catalog of Flume Tests.....	99
	APPENDIX E: Results of Permeameter Tests	131
	APPENDIX F: Base Efficiency Test	139

SUMMARY

An inventory of temporary runoff controls installed on TxDOT construction sites indicated that rock berms and silt fences were the most commonly used erosion and sediment controls on construction sites. Sediment ponds, the most inexpensive control on a cost-per-area basis, were used more frequently in the earlier stages of construction. Erosion control blankets, the most expensive controls, tended to be used in the later phases of construction.

A field evaluation of the efficiency of silt fences in removing sediment carried in runoff from highway construction sites showed that sediment was removed by settling rather than by filtration. Geotextile silt fences proved to be ineffective in reducing turbidity. Monitoring of a single rock berm showed negligible suspended solids removal.

High sediment removal efficiencies were achieved with silt fences in flume studies. Mean sediment removal efficiency in the flume was highly correlated with the detention time of the runoff. The flow rates of sediment-laden runoff through the control sections were two orders of magnitude less than those typically specified by transportation agencies. The flow rate of a sediment slurry through geotextile fences was a function of apparent opening size as well as of permittivity.

Flow rates through rock berms greatly exceeded the rates typically recommended in guidelines issued by regulatory agencies. The short detention times and large pore size of the berms resulted in only a slight reduction in the suspended solids load.

1. INTRODUCTION

The mitigation of pollution from nonpoint sources is an important environmental issue. Increased public awareness and enactment of state and federal regulations have been the response to heightened concerns over the problem of nonpoint source pollution. Stormwater runoff from construction sites is a significant component of nonpoint source pollution. Constituents of runoff may adversely impact rivers, lakes, and aquifers; e.g., soil losses from unprotected construction sites are reported to be 150-200 tons per acre per year, while the average natural rate of soil erosion is approximately 0.2 tons per acre per year (Smoot et al., 1992).

Highway construction sites are prone to erosion caused by clearing, grubbing, earth moving, grading, and ditching, which involve removal of vegetation and other naturally occurring soil stabilizing materials from the construction site (Highway Research Board, 1973). The surface areas and slopes created by excavation or embankments are exposed to the erosive forces of wind, rainfall, and snowmelt until the earthwork are completed and vegetation is restored or the surface is stabilized artificially.

Eroded soil may be transported to and deposited in surface waterways causing environmental damage. Fish spawning areas and benthic habitats may be destroyed or damaged when deposited sediments cover stream and river bottoms. Suspended solids also reduce light transmission that inhibits in-stream photosynthesis and diminishes aquatic food supply and habitat. Suspended solids also may coat aquatic organisms and cause abrasion on fish. The solids also reduce surface water quality and limit water usage for municipal and industrial supplies. Accumulations of deposited sediments diminish capacities of reservoirs and other conveyance systems (Goldman et al., 1986). The eroded soils may serve as a transport medium for phosphorus, nitrogen, and toxic compounds in aquatic systems.

Early Roman and Greek engineers identified a connection between deforestation and increased harbor sediment deposition (Crebbin, 1988); however, environmental considerations associated with construction activities are recent developments. Prior to the 1960's, construction progressed along the path of least resistance to minimize costs

and reduce construction duration (Gervais and Piercey, 1988). Increased environmental awareness and concern eventually led to the passage of the National Environmental Policy Act of 1969. This legislation initiated various strategies for the control of erosion and sedimentation and instituted permit requirements (Teamah, 1993). The Federal Clean Water Act of 1977 subsequently called for the regulation of construction runoff into surface water bodies (Crebbin, 1988).

Some groundwater systems, such as karst limestone aquifers, may be adversely affected by increases in the suspended solids of recharge water. Sediment in the creeks may obstruct openings restricting the volume of water recharged. In addition, solids moving through solution cavities in the aquifer can fill well bores, cause pump abrasion, and reduce the storage capacity of the aquifer.

The Clean Water Act requires a National Pollutant Discharge Elimination System (NPDES) permit to discharge runoff from construction sites where more than 5 acres are disturbed (Environmental Protection Agency (EPA), 1992). Part of the permitting process is the development and implementation of a Storm Water Pollution Prevention Plan (SW3P). This plan must describe the project and the appropriate sediment and erosion controls that will be used on the construction site. One of the primary sources of SW3Ps is proposed highway construction projects.

Devices commonly used for sediment and erosion control include silt fences, rock filter dams, sediment ponds, erosion control blankets, mulches, and temporary vegetation. Erosion controls (temporary vegetation, mulches, and erosion control blankets) are used to prevent erosion. Sediment controls such as silt fences, rock berms, and ponds are designed to remove sediment from the runoff after erosion.

Silt fences are temporary methods of sediment transport interception accepted by industry and regulatory agencies and are extensively employed on highway and other construction projects. Silt fences are reinforced and supported geotextile fabrics that enhance sedimentation produced by velocity reduction and reduce solids loading through filtration. Performance of silt fences under actual in-field conditions has not been evaluated in detail. The technology for sediment and erosion control is still in the

development stages and guidelines for installation and maintenance of temporary controls is often vague and based on rules of thumb.

The objective of this research task was an evaluation of the use and performance of temporary runoff control devices. The types of temporary controls in use on highway construction sites in the Austin, Texas area were identified. The drainage areas associated with each type of control were determined, and the costs of installation and maintenance of the different controls were compared. The effects of installation and maintenance practices on runoff water quality were documented at field sites. The performance of silt fences was evaluated in a comprehensive field monitoring and laboratory experimentation program. The suspended solid (TSS) removal of the most commonly used control devices was measured in the field and in a laboratory flume. The hydraulic property of these temporary controls also was documented.

2. LITERATURE REVIEW

2.1 Introduction

Two strategies for minimizing the impact of stormwater runoff from construction sites are erosion control and sediment control. Erosion control is a source management method and usually is accomplished with slope coverings. These techniques include temporary and permanent vegetation, plastic sheeting, straw and wood fiber mulches, matting, netting, chemical stabilizers, or some combination of the above. Sediment control may be considered as the second line of defense. Sedimentation ponds, post sedimentation pond devices, and silt or sediment barriers reduce sediment loads (Nawrocki and Pietrzak, 1976).

Sediment barriers are devices designed to diminish solids loading through short term retention and/or velocity reduction and filtration. Silt fences and rock berms are sediment barriers. Silt fences have been selected preferentially and installed widely because of purported advantages attributed to these devices such as effectiveness for durations greater than 6 months, stronger construction, greater ponding depth, minimum removal efficiencies of 75%, easy assembly, and relatively low cost (Goldman et al., 1986).

2.2 Sediment Removal Mechanisms

Sediment barriers capture eroded solids by sedimentation and filtration both of which contribute to the overall efficiency of a system. The most important, cost effective, and widespread treatment of suspended solids in water is by sedimentation. Gravity separation of solids that have a specific gravity greater than water has been practiced for a long time and is well understood. Stokes' law, which is applied to calculate the settling velocity of solid particles, is based upon the premises of laminar flow, no particle interaction, and spherical particles. This relationship is valid for estimating the approximate settling velocities and provides insight into factors affecting the sedimentation of smaller particles, such as silts and clays (Kouwen, 1990).

Filtration of suspended particles by temporary controls, i.e., silt fences or rock berms, involves straining and attachment. Straining is the main method of removal when the size of the suspended particle size is close to that of the filter pores. Smaller particles are removed by attachment to the filter surface. Straining is possible when a number of particles which are smaller than the filter pores arrive at a single opening simultaneously and bridge across openings. Straining causes clogging of the fabric. Nonstraining mechanisms for the removal of particles include impaction, shear, interception, sedimentation, or diffusion.

2.3 System Performance Factors

Three factors govern the removal efficiency of solids by temporary controls:

1. suspended solids load,
2. hydraulic and filtration characteristics of the fabric, and
3. maintenance of the system

The particle size of the sediment is determined by the characteristics of the parent soil, storm intensity and duration, and the path of the flow. Smaller, unconsolidated particles are displaced more easily than larger particles in compacted soils. Smaller particles remain in suspension for longer periods of time (settle slowly) and are transported readily. Therefore, sediments from construction sites typically consist of a larger percentage of fine particles (silt and clay) than the parent soil (Hittman Associates, Inc., 1976; Schueler and Lugbill, 1990). Particle size determines settling rates and the suspended sediment load on the filter. Retention through filtration is dependent upon particle size in relation to the control pore size.

Permeability and filtration efficiency affect the operation of geotextile filter fabric. Filtration efficiency is dictated by the number, size, and character of accessible pores. Larger pore sizes promote greater rates of flow and allow particles to pass through fabrics of comparable percentages of open area. Smaller pores inhibit flow and increase retention times. Thicker fabrics have longer and more tortuous paths of flow; therefore,

are characterized by lower permeabilities, longer holding times, and a greater tendency for particle interception than comparable thin fabrics (Crebbin, 1988). The fabric must not be susceptible to elongation in order to maintain the integrity and prevent deformation of fabric openings.

Other fabric characteristics that influence the operation of the system include tensile, puncture, burst, and tear strength. Resistance to climatic conditions are partially responsible for fabric longevity and the ability to circumvent failures. Tears, unraveling, or rotting severely reduce the efficiency of solids removal by the fabric.

Particle retention on the upstream face or within the width (non-woven fabric only) of the fabric and subsequent pore size reduction may result from high filtration efficiencies. This phenomenon accelerates the percentage of particle capture and causes the permeability of the fabric to be reduced from the bottom to the top. Retention times increase as the permeability declines and/or the surface area for flow is restricted. Kouwen (1990) states that extensive theoretical modeling and testing to predict flow rates and behavior has been accomplished by Bell and Hicks (1984) and by Koerner (1984, 1985).

Experimental results indicate that the sedimentation pattern is a delta formation process. Initially, large solids settle near the point of velocity reduction. Additional deposition occurs sequentially at the existing delta face until the delta reaches the obstruction created by the fence. The surface area accessible for filtration is diminished and flow through the fabric is reduced as the delta blocks the flow to a portion of the fence (Kouwen, 1990). The volume capacity is diminished over time by the deposition of sediments through settling, and may be limited by the strength of the structural support system. Uncontrolled release of suspended solids may occur by over-topping or an end run.

2.4 Silt Fences

Silt fences are temporary, vertical structures of wood or steel supports, wire mesh reinforcement, and a suitable permeable filter fabric (Goldman et al., 1986). Silt fences

are installed to reduce velocities of water flow, reduce sediment transport, and provide a physical barrier to sediment (King County, 1990).

Silt fences have been installed upstream of points of discharge of runoff, down-slope of disturbed areas where sheet flow runoff is expected, and in minor swales or ditches (Goldman et al., 1986). Silt fences also have been used around the perimeters of disturbed areas in which the maximum drainage area is less than 0.8 hectares (TxDOT, 1992a). The recommended upper range of operating conditions for silt fences are a 2:1 maximum slope behind the barrier, a 30 m maximum slope length upstream of barrier, and a $0.03 \text{ m}^3/\text{s}$ maximum rate of flow (Kouwen, 1990).

Proper installation techniques and materials are required to reduce the risk of failures such as undercutting, end runs, holes and tears, over-topping, and fence collapse (Kouwen, 1990). Installation measures include a minimum toe in of 15 cm, steel or wood post supports spaced less than 2.4 m apart and embedded at least 0.3 m, and welded wire fabric or woven wire of sufficient gauge to provide adequate reinforcement backing for the fabric and support to which the fabric may be securely affixed. The fabric selected should not be susceptible to mildew, rot, heat, ultraviolet radiation, or exposure to any other possible deleterious agent (TxDOT, 1992a).

Silt fence design guidelines can sometimes be vague and confusing. The maximum flow rate of runoff for a silt fence recommended by TxDOT (1992b) is $27 \text{ L/s}\cdot\text{m}^2$. This value is based on an average of flow rates, recommended by the manufacturers, divided by a factor of safety (Chang, 1994). Neither the area nor length of silt fence required to handle the maximum flow rate from a given drainage area is specified.

Most of the specifications for recommended flow rates are based on index tests performed by manufacturers or state testing agencies. The hydraulic characteristics of geotextiles are often described by permittivity (Ψ) and apparent opening size (AOS). Permittivity [t^{-1}] measures the ease with which water flows through the fabric. The standard test for fabric permittivity, (ASTM D4491, 1992), is conducted with clean, de-aired water at heads of 10-75 mm. The fabric is positioned in a horizontal orientation and initially supports the column of clean water. Apparent opening size is reported as a sieve

size and is the estimated largest pore size in the fabric. These tests may not give an accurate indication of performance in the field. Martin (1985) states:

It can easily be shown in the lab and in the field that a fabric with a high clean water fabric flow rate does not necessarily perform well in a sediment control application. Many drainage fabrics have very high clean water flow rates. However, their slurry flow rates are very low because their fabric structure traps sediment and inhibits slurry flow.

2.4.1 Geotextile Fabric

Burlap was the filter fabric of choice prior to the introduction of geotextiles. Unfortunately, burlap was highly susceptible to environmental decay and the filtration efficiency was questionable (Dallaire, 1976). Geotextiles typically are specified as the filter fabric for silt fence applications (Martin, 1985; TxDOT, 1992a).

The definition of a geotextile is:

any permeable textile used with foundation, soil, rock, or any other geotechnical engineering related material as an integral part of a man-made product, structure, or system (American Society of Testing and Materials (ASTM), 1987b).

The manufacture of geotextiles originated as an offshoot of the chemical and clothing industries and provides a use for waste products and excess production capacities (Kulzer, 1988). Geotextiles are manufactured from synthetic fibers or filaments such as polyester, polypropylene, or polyethylene which are bonded together by a mechanical, thermal, or chemical process (Rollin, 1986). Approximately 65% of geotextiles are constructed of polypropylene with polyester second at 32%. Nylon and polyethylene are used in the construction of the remaining 3% of geotextiles (Koerner, 1990).

The geotextile fabrics used for silt fences can be divided into two distinct structural groups: woven and non-woven. Woven fabrics are constructed of either polymer monofilaments or slits from a polymer film. Woven fabrics have uniform rectangular openings created by a weft horizontal element and a warp longitudinal element (World Construction, 1986). These fabrics essentially are two dimensional and

are often manufactured with a glossy surface texture to diminish particle adherence (Martin, 1985). Openings in woven fabrics can be nonuniform in size and are a function of manufacturing vagaries or stresses on the fabric.

Non-woven geotextile fabrics typically are manufactured of polymer fibers fused together by heat into a three dimensional orientation (Rollin, 1986). The random fiber products have experienced continued growth, increasing popularity, and diversification of application in the construction industry. Current applications include ground stabilization, asphalt underlay, drainage, and silt fences (World Construction, 1986).

2.4.2 Geotextile Characterization

Several test methods exist for evaluating the performance characteristics of geotextile fabrics. A method for segregating test methods is the division between index and design characteristics. An index characteristic provides information about the fabric but will not model field performance. Therefore, index characteristics should be used only for quality control and product comparison. Design characteristics provide data suitable for use in the design process and serve as a performance indicator (Suits, 1986).

No standard test for design characteristics is widely accepted. Current industry accepted standard test methods are typically index in nature and include characterizing geotextiles by permittivity and apparent opening size. Standard test methods for strength characteristics and resistance to degradation are important; however, minimum industry accepted values exist for these parameters, and subsequent discussion will be based upon an assumption of adequate strength performance.

The permeability of geotextiles typically is determined by permittivity as detailed by the Standard Test Method D 4491. Permittivity is defined by the ASTM (1987c) as:

the volumetric flow rate of water per unit cross sectional area per unit head under laminar flow conditions, in the normal direction through a geotextile.

Permittivity is an indicator of flow volumes in an isolated condition, and is numerically Darcy's coefficient of permeability divided by the specimen thickness [seconds⁻¹]

corrected to a viscosity at 20° C (Suits, 1986). Standard Test Method D 4491 may be conducted with either a constant head or a falling head (ASTM, 1987c).

ASTM D 4751, Standard Test Method for Determining Apparent Opening Size of a Geotextile, is accepted by most regulatory agencies. Glass beads are sieved through a fabric specimen by means of lateral shaking. The test is repeated for different bead sizes until 5% of the beads, maximum by weight, pass through the specimen. The average AOS of five tests are reported as bead size [mm] or as the number of the U.S. Standard Sieve with nominal openings equal to or just larger than the bead size (ASTM, 1987a). The U.S. Standard Sieve Sizes are given in Table 2.1 (Das, 1985).

This test is not a good indicator for non-woven fabrics because of the tortuosity of the pore passages of the fabric. The test is limited to particles with a diameter greater than 75 µm (0.075 mm), lacks reproducibility (Rollins, 1986), and does not simulate actual field conditions where graded particles may act to form a natural filtration face (Suits, 1986).

Table 2.1 U.S. Standard Sieve Sizes (Das, 1985)

Sieve Number:	Opening (mm):	Sieve Number:	Opening (mm):
4	4.750	50	0.300
6	3.350	60	0.250
8	2.360	80	0.180
10	2.000	100	0.150
16	1.180	140	0.106
20	0.850	170	0.088
30	0.600	200	0.075
40	0.425	270	0.053

2.4.3 Previous Silt Fence Research

An alternative test which may reproduce field conditions more accurately is the Virginia test method or VTM-51, (Wyant, 1993). The filtration efficiency and slurry flow rate of a silt fence fabric are determined with a suspension created using a site-specific

soil. The Virginia Test Method was developed by the Virginia Highway and Transportation Research Council and is an alternative filtration efficiency standard test method for the Virginia Highway and Transportation Department. The VTM-51 is a design type of test in which a geotextile fabric is employed as a downstream barrier in a flume. A standard design mixture of water and soil is transported to the filter barrier via the flume. Pre-filtration and post-filtration analyses and comparisons yield a theoretical filtration efficiency (Crebbin, 1988). Measurements of the time required to pass the mixture volume can be used to extrapolate a slurry flow rate per unit area of fabric surface (Martin, 1985). Flow-through rates varied from 0.13 to 0.4 L/s·m² for several silt fence fabrics and three soil types: sandy, silty, and clayey Wyant (1981).

Crebbin (1988) tested four silt fence fabrics in a flume with a procedure based on VTM-51. The site-specific soil used to prepare the slurry was Brown glacial till. This particular soil consisted mainly of sand-sized particles. Filtration efficiencies ranged from 87-91%. Crebbin (1988) noted that during the tests that the top portion of the wetted area did not pass water. He concluded that no correlation could be drawn between AOS and filtering efficiency and that efficiency is a function not only of the characteristics of the fabric tested but also of the suspension used.

Crebbin (1988) utilized an apparatus similar to the VTM-51 and a non-standard slurry mixture to evaluate the operational characteristics and efficiencies of four specific geotextile fabrics. The soil incorporated in the slurry mixture was a graded, western Washington State soil of glacial origin. Gradation curves of soil samples indicated that 92.5% of the soil by weight would be greater in size than a silt or clay (i.e., 0.075 mm).

According to the guidelines for the VTM-51, 50 L of water with 150 grams of soil were used for each filtration test. The flume was 30.5 cm tall, 80 cm wide, and 122 cm long with a slope of 8%. A 19 L bucket with three 1.2 cm diameter holes was affixed to the side of the flume for the introduction of the slurry mixture. The test mixture was divided into three equal parts, mechanically stirred, and successively poured into the introduction container. A plastic gutter was mounted at the end of the flume and connected to a 75.7 L (20 gal) container to collect the filtered water.

Influent samples from each of the three test portions were collected and mixed to result in a 500 mL influent sample. A 500 mL sample also was collected from the effluent container. The samples were analyzed for total suspended solids (TSS). Crebbin (1988) reported filtration efficiencies which ranged from 87% to 91%. A comparison of these efficiencies with those reported by manufacturers indicated that the AOS parameter was not a valid parameter to indicate efficiency and that the standard VTM-51 filtration efficiencies reported by manufacturers were influenced by the gradation of the soil in the test slurry mixture (Crebbin, 1988).

Kouwen (1990) also completed a laboratory evaluation of the effectiveness of silt fences using a model filtration apparatus which was similar in principle to the flume utilized for the VTM-51 and Crebbin's test. However, the method of slurry introduction was substantially more technical and filtration efficiencies for straw bales and rock berms could also be evaluated. A series of stilling tanks allowed the capture of test water and solids. A jet pump was placed near the bottom of the primary settling compartment and an electric pump was positioned near the water surface at the final settling bin. The two pumps were operated in tandem to provide constant slurry flows of sustained duration. The ancillary equipment allowed Kouwen (1990) to monitor efficiencies and operational characteristics over test periods of five hours. The test sediment was a poorly graded number 56 Barnes silica sand with an average particle size of 0.2 mm (medium sand).

Influent and effluent samples were collected and analyzed for TSS. Reported filtration efficiencies were 99% to 100% over extended periods of evaluation. Efficiencies for five centimeter rock berms degraded rapidly over time and ranged in value from -125% to 100%. Straw bales typically performed well, although in a single experiment no solids were removed. No discussion of negative efficiencies were included in his report (Kouwen, 1990).

Kouwen (1990) concluded that geotextile silt fences were effective filtration media; however, properly installed straw bales rivaled geotextile performance. He also reported that less permeable fabrics facilitate greater system efficiencies, but the increased possibility of clogging and over-topping which must be considered in fabric selection.

Horner et al. (1990) conducted a two year investigation of erosion and sediment control measures. The analysis of in-field performance of silt fences was included. Silt fences were placed perpendicular to the slopes on two test plots. The effluent for these two plots was compared with the effluent from two bare soil control plots with no control measures installed. Settleable solids and turbidity reductions were calculated as percent unit reductions rather than in terms of mass loadings reductions. The results indicated removals of 85.7% TSS, 25.7% of settleable solids, and 2.9% of turbidity. These data indicated that silt fences were fairly effective in trapping suspended sediments but were of minor influence in the reduction of settleable solids and turbidity (Horner et al., 1990). The disparity between efficiencies of TSS removal and the reduction in settleable solids was not discussed.

Schueler and Lugbill (1990) evaluated transport and sedimentation mechanisms as part of the operational efficiency of silt fences for active construction sites in Maryland. They state that changing conditions are typical of construction sites and the resultant monitoring and site constraints often lead to difficulties in data collection (Schueler and Lugbill, 1990).

Four sediment basins and two rip-rap outlet sediment traps were monitored over ten storm events from December through May (Schueler and Lugbill, 1990). A total of 233 grab samples of inflow, pond, and outflow locations were collected. The performance was expressed as Instantaneous Removal Efficiency (IRE) which is the change in sediment concentration computed by a comparison of inflow to outflow concentrations. Schueler and Lugbill (1990) acknowledged that an IRE is an approximate measure of performance and is subject to considerable sampling errors. Accuracy improves for large numbers of individual values.

Schueler and Lugbill (1990) also incorporated a laboratory sedimentation analysis of field collected specimens. A 1.5-m tall by 0.15-m internal diameter acrylic settling column with 6 sampling ports at 0.3 m intervals was used. Samples from each port were collected at 0.5, 2, 4, 6, 12, 24, and 48 hours. Sediment concentrations were plotted against time to determine settling rates. They found that 90% of the incoming sediment load was comprised of particles smaller than 15 μm (0.015 mm). The size of the

remaining 10% ranged from 15 to 50 μm (0.015 to 0.050 mm). This particle distribution was skewed to the smaller sizes as compared with the parent soil. Conspicuous delta formation in certain locations indicated that sand sized particles were transported to the basins and represented a minor constituent of the total particle load. However, these particles were not detected through grab sampling and analysis methods because of the tendency to saltate along the bottom of flow channels and settle rapidly.

The computed IRE ranged from -293% to 100%. Schueler and Lugbill (1990) estimated that sediment basins will remove approximately 50% of the total suspended particle load and less than 15% of turbidity. Approximately 60% of total settling occurred within six hours, and the settling rates decreased dramatically beyond that point in time. The median sedimentation rate observed was 104 mm per hour. Sediment removal capabilities were highest for early stages of construction and storm events of less than 19 mm of rainfall.

Runoff containing a monodispersed sediment (diameter of 0.2 mm and settling velocity of approximately 10 cm/s) was used in laboratory flume tests by Kouwen (1990). These solids deposited in the flume as the velocity of runoff decreased and the water formed a pool. Silt fence fabrics, burlap, straw bales, and rock berms also were tested and filtering efficiencies greater than 95% were reported for three silt fence fabrics (Carthage FX300C, Terrafix 370RS, and Exxon 100S). Kouwen (1990) noted that flow-through rates in flume tests ranged from 6.9 L/s/m² for a silt fence fabric to 127 L/s/m² for burlap.

2.5 Rock Berms

Rock filter dams or rock berms are mounds of graded rock placed on a contour to intercept runoff, retain sediment and create sheet flow by dispersing the stormwater over a wider area. Rocks used in the berms typically are 7.5 cm - 15 cm in diameter. TxDOT (1992a) recommends a maximum runoff flow rate per submerged area of rock berm of 40 L/s·m². Rock berms at times are preferred over silt fences because of lower maintenance requirements and cost. They also are better suited for use in channels or ditches with concentrated flow.

Weber and Wilson (1976) monitored the TSS concentrations in grab samples of runoff taken above and below several dams constructed of various materials, placed in waterways draining a highway construction site in Pennsylvania. Sediment loads trapped upstream of dams were estimated volumetrically and the contents were graded. Rock dams were observed to trap the bedload but that data was too variable to determine any reductions in TSS concentrations in the runoff. Reed (1978) reported approximately 5% reductions for both turbidity and suspended sediment load based on grab samples taken above and below rock berms on highway construction sites in Pennsylvania.

Filtering efficiencies of approximately 30% for 5-cm rock berm and 90% for pea gravel at a 10% slope were reported by Kouwen (1990) using a monodispersed sediment. Filtration efficiencies increased for the 5-cm rock berm as the slope decreased. Flow rates of 2.3 L/s and 5.1 L/s were reported respectively for pea gravel and 5-cm rock at a head of approximately 150 mm.

2.6 Summary

Temporary sediment controls remove solids by both sedimentation and filtration. The efficiency of these controls is affected by the particle size distribution of the construction runoff, characteristics of the control material, and the level of maintenance. Silt fences are one of the most commonly employed temporary controls. The fences are supported geotextile fabrics which are commonly characterized by their permitivity and apparent opening size, even though these parameters may not be appropriate for estimating sediment removal or hydraulic performance in the field.

Previous research on the sediment reduction of silt fences has shown high removal in laboratory settings. However, in many of the studies, the solids used to create a sediment slurry had much larger diameters than the particles generally encountered in storm water runoff. Sediment removal effectiveness in the field have not been well documented. Even where high solids removal has been reported, the silt fences were not effective in reducing turbidity.

Much less research has been directed at characterizing the performance of rock berms. They appear to be much less effective than silt fences in reducing suspended solids loads.

3. INVENTORY OF TEMPORARY CONTROL DEVICES

3.1 Methodology

An inventory of the temporary erosion controls used by TxDOT at highway construction sites was made. Erosion control devices surveyed in the field were categorized according to location, type of control (silt fence, rock berm, sedimentation pond, etc.), dimensions, drainage area, and watershed. The geographic boundary of the inventory was the Barton Springs segment of the Edwards aquifer recharge zone. The active TxDOT construction projects in the study area are listed in Table 3.1 and shown in Figure 3.1

Table 3.1 List of Temporary Control Inventory Sites

Loop 360 and US 290 Interchange
Loop 1 from Slaughter Lane to Hannon Drive
State Highway 45 from Loop 1 to FM 1826
RM 967
Loop 360 at Westbank Drive
Loop 1 Hazardous Material Traps at Gaines Creek

Erosion controls in the field were plotted on maps and the inventory data were tabulated. The correlation between the location of the actual device in the field and the location on the map was facilitated by the survey station numbers.

Field measurements of the size and placement of controls were made with a Rollatape® measuring wheel. Drainage areas for individual installations were calculated from the maps using either a scale or planimeter. When this method proved impractical because of discrepancies between the plans and changing conditions on the construction site, the drainage area was estimated using the field measurements. The areas bordering the rights of way on the Loop 1 and State Highway 45 projects were contributing to the runoff. Those contributing drainage areas were calculated using a planimeter and a USGS topographical map with watersheds and highway right-of-ways superimposed.

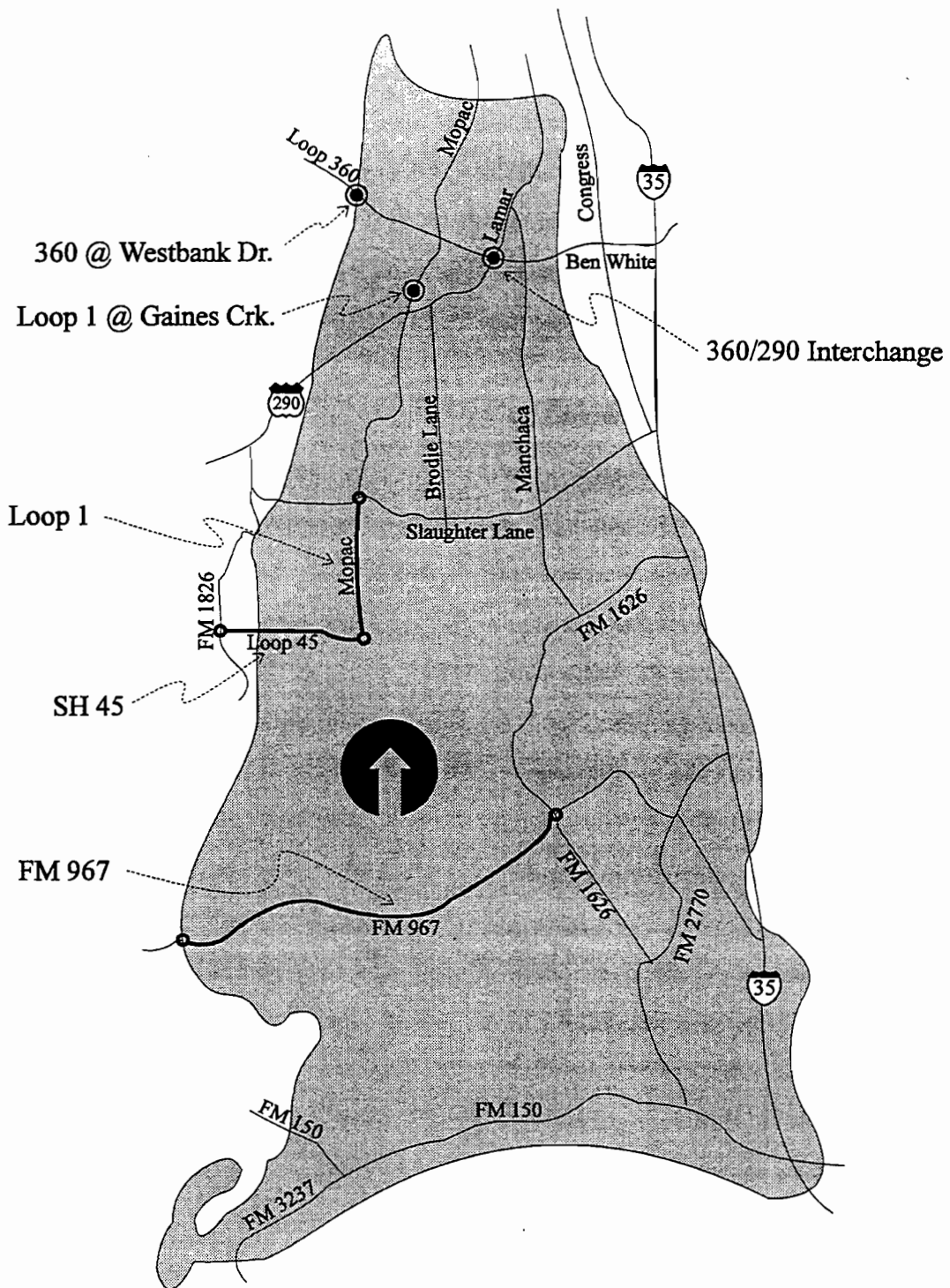

Figure 3.1 Location of Inventoried Sites

The cost for each installation was based on the bid price of the contractor and the amount of each type of control observed during the inventory. The bid prices are preconstruction estimates and the actual cost could have been either higher or lower depending on the actual quantity of material used in the specific job. The cost per area drained was calculated for each control type to compare the cost effectiveness of the different types of controls. For example, the cost per hectare drained for both silt fences and erosion control blankets can be compared; however, a comparison of the meters of silt fence to square meters of erosion control blankets is not relevant.

3.2 Inventory Results

The inventory of temporary runoff controls was conducted between October 1993 and January 1994. This short time span allowed only a glimpse of some of the controls that might be used during the life of a highway construction project. The fact that there were six active sites in the study area permitted some diversity in the phases of construction observed.

The quantities, drainage areas, and costs of runoff controls at the six sites inventoried are summarized in Table 3.2. Rock berms were used most commonly in the study area, treating drainage from 53% of the area of the six sites. Silt fences and sedimentation ponds were runoff controls used on 23% and 22% of the total area, respectively. Erosion control blankets (ECB) were used over 6% of the study area. These results are shown graphically in Figure 3.2.

Construction activities at sites on State Highway 45, Loop 1, Loop 360 and Westbank Dr., and the hazardous material traps (HMT's) at Loop 1 and Gaines Creek were near completion. The projects at the US 290 and Loop 360 interchange and on RM 967 were in earlier stages of construction. The data presented in Figure 3.3 show that the sites with construction activities nearing completion relied on erosion control blankets much more than sites in the earlier stages of construction, since erosion control blankets are typically placed on surfaces after the final grading is complete. Sediment ponds appeared to be used more on sites that are in the earlier stages of construction.

Table 3.2 Costs of Temporary Controls per Drainage Area, \$/hectare

Control Type	Dimension	Drainage Area, ha	Cost, \$	Cost /Hectare
Silt Fences	Length, m			
290 & 360 Interchange	2,800	21.9	18,366	839
Loop 1	202	30.9	862	28
SH 45	826	25.8	3,604	140
RM 967	891	1.1	4,385	3828
Loop 360 & Westbank	200	1.4	1,084	774
Loop 1 HMT's	438	4.9	4,305	872
Rock Berms	Length, m			
290 & 360 Interchange	432	20.2	19,300	956
Loop 1	109	36.5	2,890	79
SH 45	752	131.9	25,174	191
RM 967	55	2.7	2,548	948
Loop 1 HMT's	128	2.3	11,700	5072
Sediment Ponds	Volume, m ³			
290 & 360 Interchange	4,159	37.6	207,000	5,500
Loop 1	36	12.1	474	39
SH 45	847	27.0	5,679	211
RM 967	15	2.2	100	46
Erosion Control Blankets	Area, m ²			
290 & 360 Interchange	6,592	0.7	7,881	11,955
Loop 1	27,936	2.8	27,980	10,016
SH 45	23,379	2.3	29,878	12,780
Loop 360 & Westbank	2,837	0.3	3,731	13,151

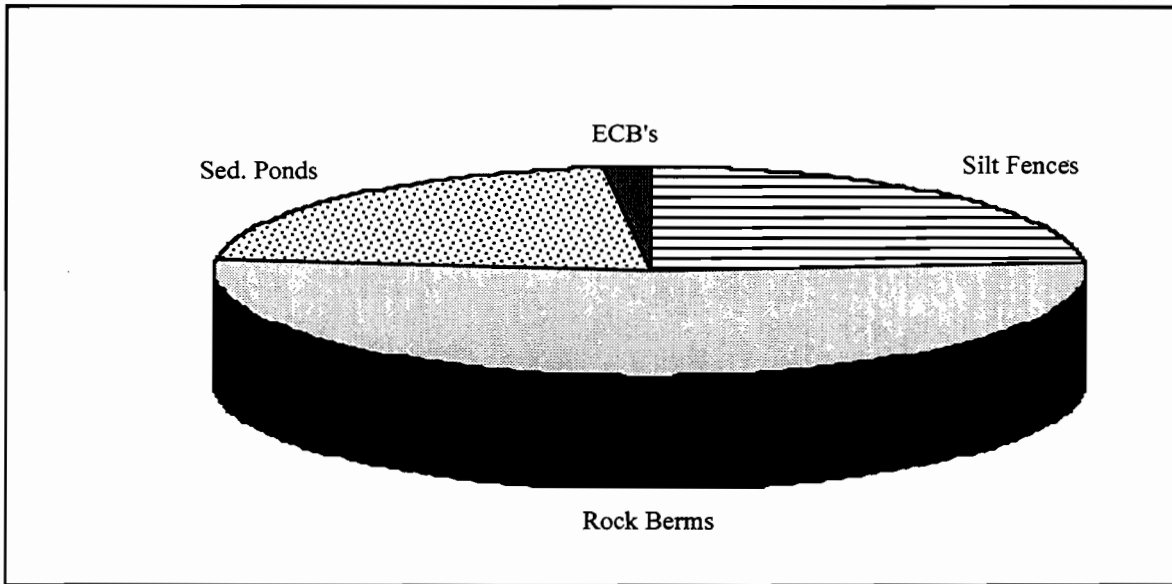

Figure 3.2 Fractions of Total Study Area Drained by Control Types

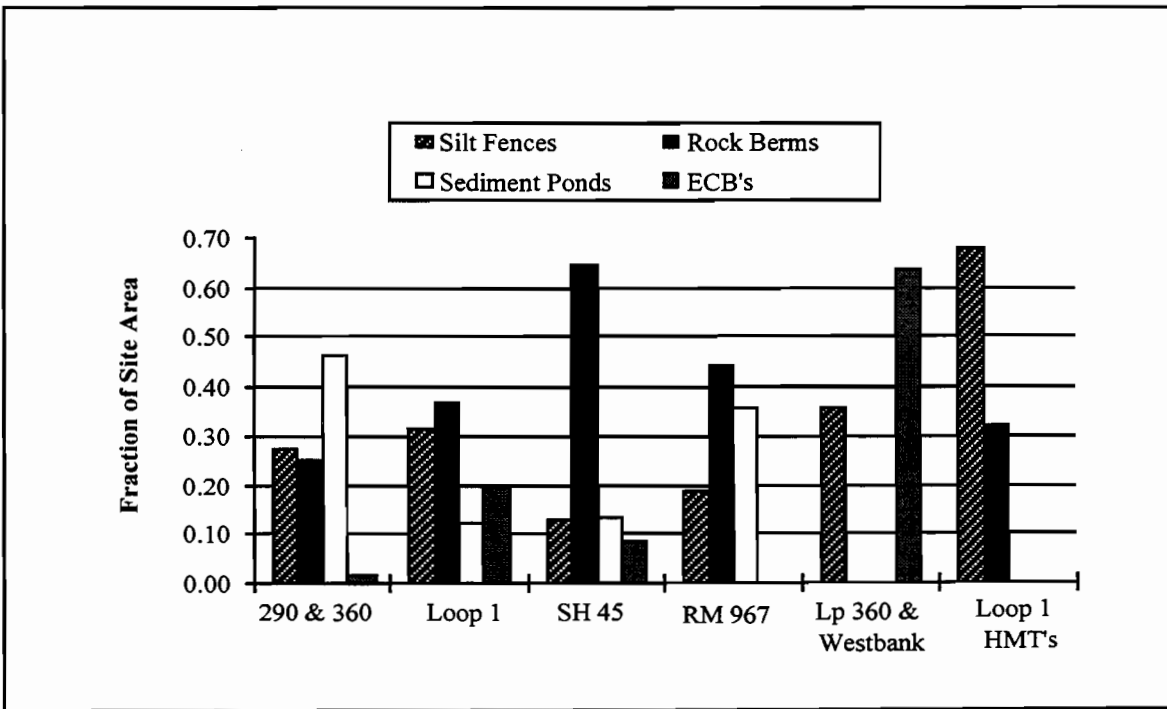

Figure 3.3 Fraction of Each Site Drained by Control Type

The inventory data indicate that silt fences and rock berms are the most economical controls over the entire study area on a dollar-per-area-drained basis. However, the higher unit costs calculated for sedimentation ponds was caused by one large temporary pond at the US 290 and Loop 360 interchange site. Much of the cost for this pond was incurred in excavation. Sedimentation ponds were more cost-effective than either silt fences or rock berms when this particular pond is excluded from the comparison. The average cost-per-area-drained for the six sites surveyed was \$151/ha for sedimentation ponds (excluding the pond at the highway 290/360 site), \$379/ha for silt fences, and \$318/ha for rock berms. Erosion control blankets, used solely to prevent erosion, are very expensive devices (\$11,437/ha).

4. FIELD MONITORING OF TEMPORARY CONTROLS

4.1 Introduction

Evaluation of the performance of temporary controls in an operational setting required an extensive field monitoring program. The sediment removal efficiencies of silt fences and rock berms were determined from samples taken during storm events on highway construction projects.

4.2 Field Performance of Silt Fences

Silt fence installations on active highway construction sites were evaluated in terms of efficiency of total suspended solids (TSS) removal and turbidity reduction. The dynamic nature of a construction site required research methods which afforded a large degree of flexibility. The entire process consisted of:

1. selection of construction project and study site,
2. sample collection, and
3. sample analysis.

The highway construction site selection was based on ease of access defined by proximity, accessibility, cooperation from TxDOT construction supervisors and the contractor, and the availability of silt fence installations. The improvement of Ben White Boulevard (US 290) from Banister Lane to Interstate 35, in Austin, Texas, was selected as an appropriate study area based on these considerations. The project location is shown in Figure A1 in Appendix A.

The specific silt fences were selected based on availability and installation configuration. Silt fences which received only limited amounts of sheet flow were not suitable for evaluation. Only installations with moderate flows and/or retention volumes sufficient to permit sampling were feasible for evaluation. Normal construction processes governed installation and maintenance at the sites selected. The longevity of any particular site was not guaranteed as construction activities progressed. The transitory

nature of construction activities resulted in removal of silt fences from operation, changes in configuration, or flow diversions resulting from the progression of construction.

Samples were collected from six specific construction sites using silt fences. The approximate locations of the sampling sites are detailed in Figure A2 in Appendix A. Schematic representations of the installation configurations and collection locations are presented in Figures A3 through A17 in Appendix A. Two installations incorporated non-woven fabric and four employed woven fabric.

4.2.1 Sample Collection

Manual grab sampling with 1-L plastic containers was selected as the most appropriate method of sample collection. This method of sampling requires the presence of the researcher and allows the opportunity to make operational observations during runoff events. A basic plan of action was formulated; however, variations in the procedure were necessary since individual rainfall events and site conditions dictated specific collection methodologies. Depth requirements for sampling could be satisfied only through runoff created from rainfall events of moderate to heavy intensity and/or duration. The adequacy of an event was determined on site to fully exploit the limited sampling period. Regardless of difficulties in access, every possible precaution and consideration were exercised to secure the most representative sample in all cases. Uncontrolled discharges caused by tears, over-topping, end-runs, and under-flow failures were excluded from sampling.

Each specific sample was assigned an alphanumeric designation for identification and was catalogued according to relative position in regard to silt fence, the site, date, and time of collection. For the sampling period, February 1 to June 14, 1993, 108 individual samples were obtained for seven rainfall events. Additionally, 14 field composited samples were collected from three events. This information is compiled and presented in Tables A1 and A2 in Appendix A. Specific information regarding the intensity, duration, or quantity of each rainfall event was not obtained because of limited equipment on site.

4.2.2 Sample Analyses

The data collected to determine water quality during the silt fence field study included:

1. Total Suspended Solids
2. Turbidity
3. Classification of Suspended Particle Size.

The results of the analyses are presented in Tables B1 and B2 in Appendix B. A detailed description of the laboratory methods are presented in Appendix C. The extent of analyses performed were subject to personnel and equipment limitations.

4.2.3 TSS Reduction Efficiency of Silt Fences

Samples were collected from three significant locations at silt fence installations: above the pool, in the pool behind the silt fence, and downstream of the silt fence. It was originally surmised that collection of samples from these three stages would allow differentiation between the effects of sedimentation and filtration. Maximum solids concentrations were anticipated in active flow stages where velocities were highest and the capacity for entraining and retaining particles in suspension was greatest. Differences in concentrations at these three locations should allow determination of the removal by filtration and sedimentation, as well as overall efficiency.

In principle, the concept was sound and is similar to methods used by Schueler and Lugbill (1990). The magnitude and random nature of the measured concentrations indicated that an instantaneous comparison of these values was not valid. The rate of delivery of sediment load to the pond varies over time, and the pond, by nature, is a time buffer between inflow and silt fence; therefore, the discrepancy easily could be attributed to time. An accurate estimate of the overall operational efficiency should be approximated by collecting enough samples over the duration of a storm to determine the total load into and out of the control device. An accurate characterization was possible of the effluent being discharged from the silt fence controls. The mean TSS concentration in

the discharge was 1542 mg/L, with a median concentration of approximately 500 mg/L. The large difference between the two values is the result of a single sample with an extremely high concentration, so the median is probably more representative of the water quality normally discharged from these structures.

The efficiency of the geotextile silt fences was based upon a comparison of the particle loading of the upstream pond and the effluent downstream. This procedure allowed the determination of the removal efficiency of the silt fence alone and ignored removal attributed to sedimentation. The TSS removal efficiency was calculated by:

$$\text{TSS reduction \%} = \frac{\text{Upstream TSS (mg/L)} - \text{Downstream TSS (mg/L)}}{\text{Upstream TSS (mg/L)}} \times 100$$

The median removal efficiency determined in this manner was 0%, with a standard deviation of $\pm 26\%$. The range in calculated efficiencies was -61% to 54%. A negative reduction signifies an observed increase in TSS downstream of the silt fence. Minor errors for in-situ sampling at construction sites are typical. Other sources of error which could result in negative removal efficiencies include: disturbance of bottom sediments during sample collection and commingling of filtered and unfiltered flows below the silt fence. The TSS removal efficiencies for sample pairs are presented in Table B3 in Appendix B.

The highest removal rate calculated was 54%. This removal corresponds to samples collected for a non-woven fabric, inlet perimeter protection silt fence at Site 4. The higher efficiency may be attributed to shallow depth of the ponded water. The maximum depth at this location was estimated to be only 15 centimeters. Using Stokes' Law, and assuming:

kinematic viscosity = 0.01 cm²/s,
particulate specific gravity = 2.65, and
median particle size = 9.5 μm (small silt),

the settling velocity would be 0.08 mm/s. At a depth of 150 mm, 50 % of the particles would settle in 30 minutes. Although the duration of retention varies and was not measured, these figures seem reasonable.

In one case, the effect of sustained retention was evaluated. Blockage of the lower-most region of the fence at Site 1 enabled collection of a sample from the upstream pond approximately eight hours after a storm. The TSS of this sample was 43 mg/L. An average of all other upstream pond samples at this location should yield an adequate basis for comparison even though the causal storm event was not sampled. The arithmetic mean of TSS concentrations of previous samples in this pond was 123 mg/L. Therefore, a 65% TSS reduction was attributed to sedimentation in 8 hours. The 65% particle removal is consistent with data reported by Schueler and Lugbill (1990). At a depth of 300 mm and using the assumptions listed above and Stokes Law, at least 35% of particles are smaller than 0.3 mm:

$$V_{s65\%} = \frac{30\text{cm}}{8\text{hour}} \times \frac{1\text{hr}}{60\text{min}} \times \frac{1\text{min}}{60\text{sec}} = 0.00104\text{cm} / \text{s}$$

Stokes' Law:

$$0.00104\text{cm} / \text{s} = \frac{1}{18} \times \left[\frac{981\text{cm} / \text{s}^2}{0.01\text{cm}^2 / \text{s}} \times (2.65 - 1) \right] \times d^2$$

$$d = 0.3 \text{ mm}$$

The generally poor removal efficiency due to filtration can be explained by an analysis of the particle size of samples. Silt and clay sized particles comprised the majority of the solids collected from the pond and below the silt fence. The percentage of silt and clays ranged from 68 to 100%, with a median value of 96%. The percentage of silt and clay for all samples is listed in Table B2, Appendix B. The predominance of small particles in the samples is attributable to the nature of the parent soil and to settling of the larger particles in the ponds prior to sampling. The silt and clay sized particles

remained in suspension and were able to pass through the silt fence because the diameters were smaller than the apparent opening size (AOS) of the fabric.

4.2.4 Turbidity Reduction Efficiency of Silt Fences

The amount of turbidity reduction caused by silt fences was determined by comparing concentration in the pond created by the silt fence and concentrations in samples collected below the silt fence. The calculated removal efficiency for silt fences is:

$$\text{Turbidity reduction \%} = \frac{\text{Upstream Turbidity} - \text{Downstream Turbidity}}{\text{Upstream Turbidity}} \times 100$$

The median removal for all samples was only 2%, with a standard deviation of $\pm 10\%$. Removals range in magnitude from -32% to 49%. The computed values for all samples are presented in Table B4 in Appendix B. Increases in turbidity below the temporary control fence probably are the result of the same sources of error that resulted in negative removals for TSS. Since turbidity is a function of the number of small particles in a sample, these results are consistent with the finding that all of the particles remaining in suspension above the fence are smaller than the AOS of the fabric and consequently no reduction should be expected except for the particles which become attached to the fabric.

4.2.5 Observations of Silt Fence Performance

Comments of construction project supervisors indicate that maintenance of temporary controls was not a consideration. Controls are removed or replaced frequently because of changing conditions on the construction site so that maintenance seldom is needed. However, various installation and maintenance deficiencies were noted during the duration of the study.

These silt fence installations are not designed as hydraulic structures to accommodate runoff from a rainfall event of a particular frequency, and failures caused by volumes of runoff that exceed the capacity are common. A single release around the

end of a silt fence was observed at Site 1 (see Figure A3 in Appendix A), and over-toppings at Sites 2 and 6 were observed (see Figures A4, A14, A16, and A17 in Appendix A). In all cases auxiliary installations were in place downstream to control sediment release.

Failures or uncontrolled releases are not catastrophic if an installation of silt fence is adequately supported with downstream relief structures. Deficiencies in levels of performance caused by improper installation and maintenance give rise for concern. Observed inadequacies include:

- inadequate fabric splice at Site 1,
- sustained failure to correct the fence damage resulting from the over-topping at Site 2,
- two large holes in the fabric at Site 4,
- under-runs at Site 4 due to inadequate “toe-ins”, and
- silt fence damaged and partially covered by the temporary placement of stockpiles of materials.

4.3 Field Monitoring of a Rock Berm

A field-water quality monitoring site was installed at a concrete box culvert at Outfall 2, which was the runoff outlet for a 28 hectare drainage area. The watershed was composed of a mixture of highway construction, road surfaces, and a minor amount of commercial development. A rock gabion formed one side of a small detention basin downstream of the culvert. During rainfall events, grab samples were taken below the rock berm at the same time automatic samples were taken at the culvert. A plan view of Outfall 2 showing the rock berm and sampling equipment is presented in Figure 4.1. The sampling equipment at Outfall 2 was dismantled because of the postponement of the construction of the storm water pollution-abatement facilities due to right-of-way problems; however, 12 paired samples were taken prior to the removal of the sampler.

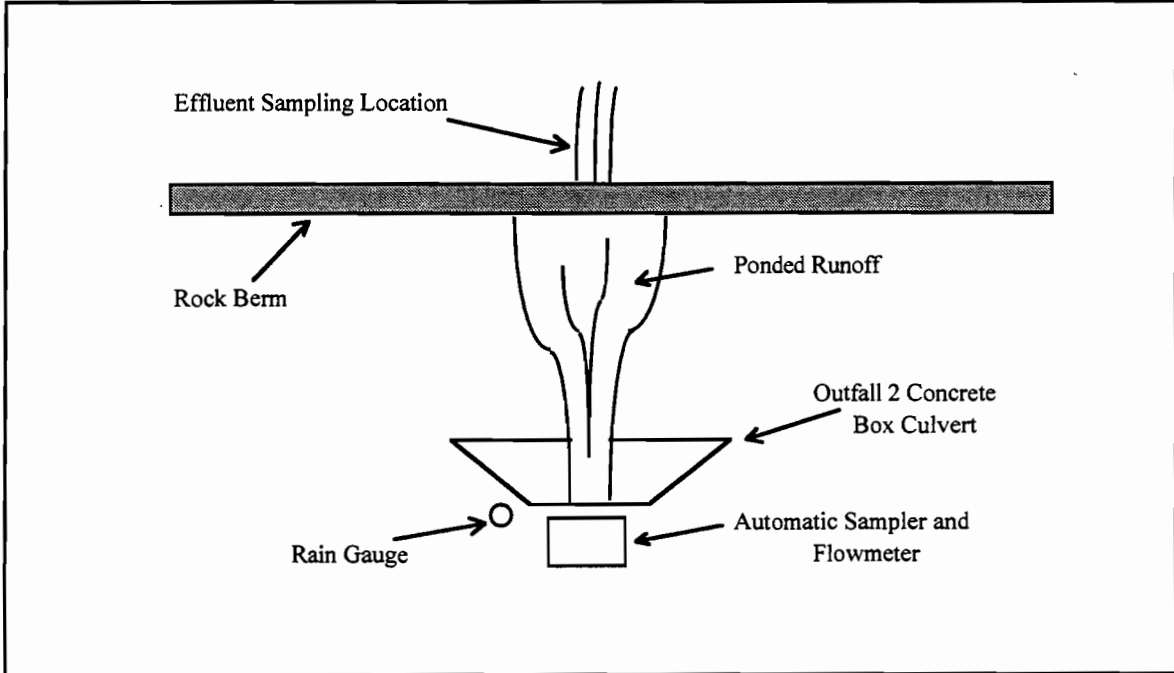

Figure 4.1 Plan View of Outfall 2 Rock Berm and Sampling Equipment

4.3.1 TSS Reduction Efficiency of Rock Berms

The efficiency of rock berms was not the focus of this study; however, a limited opportunity to collect influent and effluent samples in relation to these devices was present concurrently and without distraction to the main investigation. The number of these occasions was small, and the results should be considered accordingly.

The rock berm monitored at Outfall 2 showed negligible TSS removal efficiency. A comparison of paired samples taken above and below the berm during natural rainfall events is shown in Figure 4.2. The data presented in Figure 4.2 indicate that the TSS removal efficiency of the rock berm was negligible.

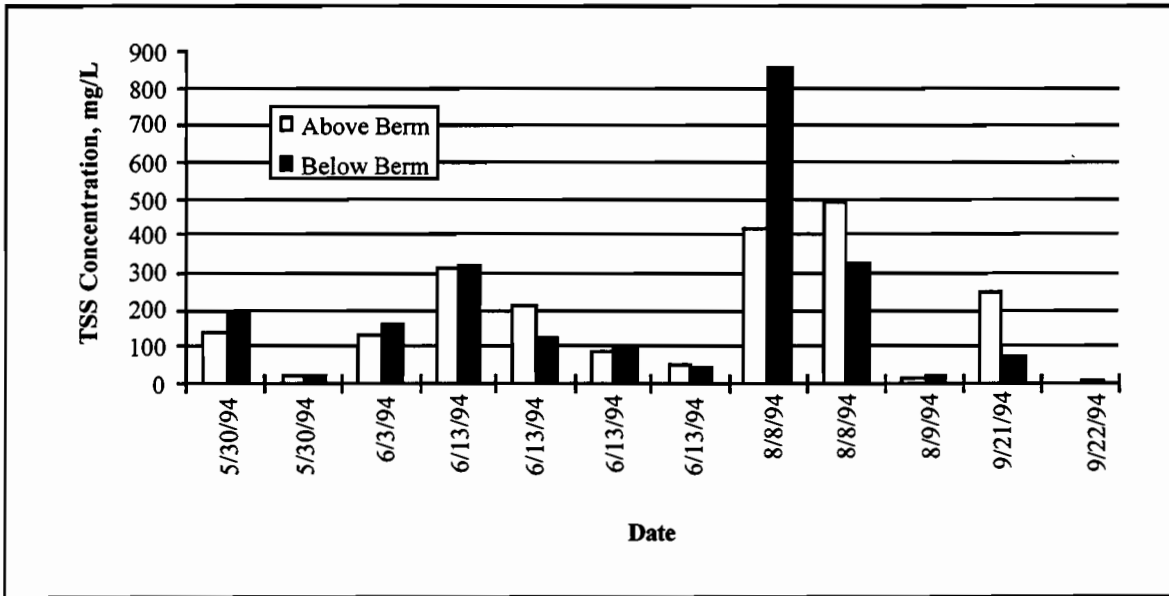

Figure 4.2 TSS Concentration of Samples Above and Below Rock Berm

5. LABORATORY TESTS OF SILT FENCES AND A ROCK BERM

5.1 Flume Tests

The sediment removal performance for the two most common temporary controls in the inventory, silt fences and rock berms, was investigated under control conditions in an outdoor flume. Monitoring controls in a flume allowed control over such variables as the influent flow rate and TSS concentrations. Data were collected using simulated runoff events in the flume. The hydraulic characteristics of these controls also were evaluated.

5.1.1 Flume and Bulk Water Delivery System

An outdoor flume at the Center for Research in Water Resources (CRWR) was used as the test bed for the sediment control experiments. The steel flume was 61-m-long with a cross-section that is 0.76-m wide and 0.6-m deep. The slope of the flume is approximately 0.33 %. A 10-cm sand and gravel bed was used to simulate field soil conditions. The thin layer of highly permeable soil allowed some infiltration, which might be expected in the field. The flume and water delivery system used for the sediment control tests are shown in Figure 5.1.

Bulk water was circulated through the elevated water tank near the head of the flume. The water level in this tank was sufficient to drive the simulated runoff through the mixing tank, flume, and sediment controls. Water for each test was drained from the elevated tank, over a V-notch weir and into the rapid mixing tank at the head of the flume. A constant head in the elevated water tank was maintained to provide a constant flow rate to the mixing tank.

The V-notch weir allowed the measurement of the bulk water influent flow rate into the flume. The weir was calibrated by filling a sealed section of the flume at different flow rates and monitoring the rate of change of the water level. The product of the constant surface area of the test section of the flume and the rate of change of the level

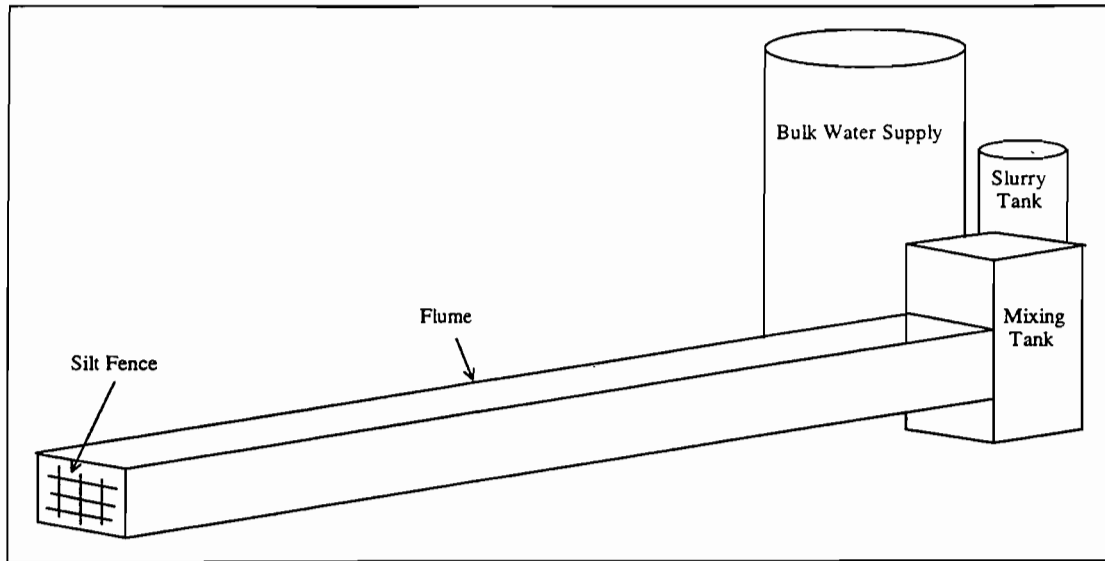

Figure 5.1 Flume and Testing Apparatus

was equal to the flow rate over the weir. The relationship between the head on the weir and the flow rate of water was approximated by the following equation :

$$Q = 365 h^{2.43}$$

where: Q = flow rate in liters per second (L/s);

h = head over the weir in meters (m).

The silt fences and rock berm were placed in the flume at a distance of 7.6 m from the mixing tank. The ponded surface area created as the runoff filled the flume was important in the calculation of the TSS removal efficiencies and flow rates of the various control devices. Water levels in the flume were monitored over time; therefore, flow rates through the controls were calculated by multiplying the pond surface area by the rate of change of the surface level.

The mixing tank was separated from the flume by a baffle wall; therefore, the surface area of the mixing tank was included in the total ponded surface area (5.12 m²). During the draining portion of the test, sedimentation occurred in the mixing tank as well as in the flume and runoff from the mixing tank drained through the sediment controls

along with runoff from the flume. The filling period of the test stopped when either the water level in the flume reached 0.35 m or the slurry tank was emptied.

5.1.2 The Soil and Suspended Solids Slurry

Top soil (Austin silty clay) was used to create the simulated runoff. Various properties of Austin silty clay are presented in Table 5.1 and Table 5.2.

Table 5.1 Soil Characteristics (SCS, 1974)

Parent material	Austin chalk
Hydraulic Conductivity	1.5-5 cm/hr
Available water capacity	0.15-0.18 m/m
pH	7.9-8.4
Shrinkage limit	11.4 %
Plasticity index	36 %
Liquid limit	64 %
Lineal shrinkage	20.9 %
Volume shrinkage	50.5 %

Table 5.2 Mechanical Sieve Analysis (SCS, 1974)

Particle Size, mm	Percent Passing
4.7	100
2.0	99
0.42	98
0.074	92
0.05	89
0.005	58
0.002	42

The soil was screened through a # 8 sieve (3 mm) before being mixed with water to make a slurry. At the outset of this work, we expected all the soil added to the slurry to become suspended; however, a fraction of the silty clay did not become suspended. This phenomenon created difficulties in proportioning the soil and water in the slurry. The

weight of soil to be mixed with water was approximately 13.5 kg per unit flow of influent runoff (L/s). This proportion yielded a TSS concentration of approximately 3,000 mg/L which was in the upper range of runoff concentrations observed in the field (McCoy, 1993) and is the concentration used in ASTM D 5141 (VTM-51 test method, Wyant, 1993). When influent flow rates were varied to suit the hydraulic behavior of the control being tested, the amount of soil added was changed to maintain the appropriate TSS concentration in the influent.

A particle size gradation analysis was performed on the solids suspended in the simulated runoff used in the flume tests. Procedures were followed as outlined in ASTM D 422 and D854. The samples were flushed with distilled water through a series of sieves ranging in size from #25 to #200 (0.72 to 0.075 mm), and the solids retained on each sieve and passing the #200 sieve was dried and weighed. A portion of the amount of solids finer than the #200 sieve was subjected to gradation analysis by hydrometer. The particle size distribution of the solids suspended in the simulated runoff is presented in Figure 5.2. The particle sizes, the three different settling regimes, the percent of mass finer than each particle size, and calculated terminal settling velocities are summarized in Table 5.3.

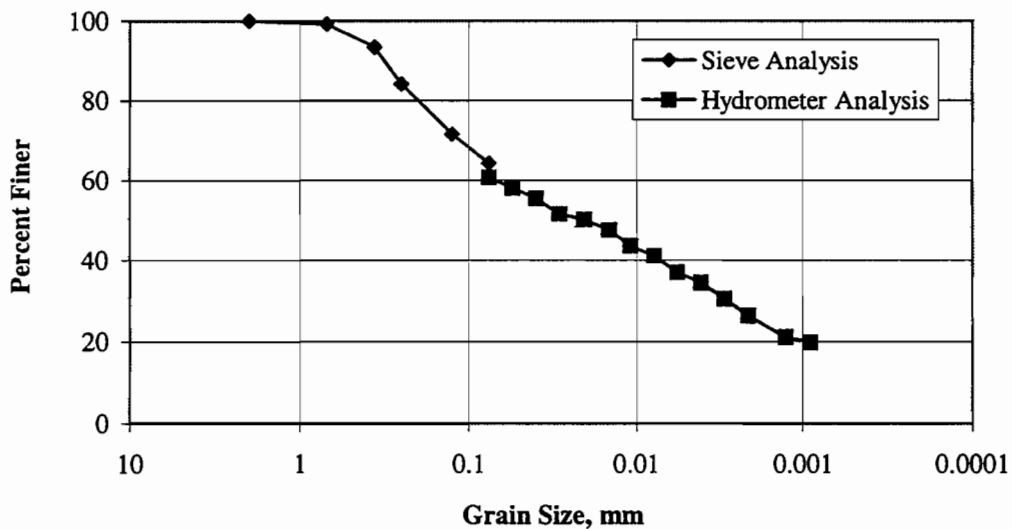

Figure 5.2 Influent Particle Size Distribution

Table 5.3 Grain sizes, Gradation, Reynolds Number, and Settling Velocities of Simulated Runoff Particles

	Particle Diameter, mm	Percent Smaller by Weight	Reynolds Number	Settling Velocity, mm/s
	2000	100	41250	309
	700	99	8541	183
	360	93	3150	131
Newtonian Settling Ends	250	84	1823	109
Transition Begins	125	72	600	101
	75	64	230	59
	55	58	124	40
	39	56	65	29
	29	52	34	21
	20	50	16	15
	15	48	8	10
	11	44	4	5.4
	7.9	41	2	4.0
Transition Ends	5.7	37	1	2.3
Stokes Settling Begins	4.1	34	0.27	0.98
	3.0	30	0.10	0.51
	2.1	26	0.038	0.27
	1.3	21	0.0079	0.09
	0.9	20	0.0029	0.05

The slurry flow rate into the mixing tank was considered to be constant over the infilling portion of the test, even though drainage was by gravity. The average slurry flow rate typically was 0.08 L/s and the bulk flow rates ranged from 1.6 to 4.4 L/s. Any variations in the slurry flow rate were negligible compared to the sum of the bulk water and slurry flow rates.

Approximately 190 L (50 gal) of the slurry were constantly mixed in the slurry tank and drained into the rapid mixing tank during the filling portion of each test. The suspended soils slurry and bulk water were mixed with a rotary paddle. The runoff flowed through a baffle wall into the flume and down to the sediment control.

5.1.3 Sampling and Monitoring

The resulting pool of runoff drained through the sediment control and the water level in the flume upstream of the sediment controls was monitored with an ISCO

recording flow meter. Grab samples of the influent were taken from the mixing tank during the filling portion of each test. Effluent samples were collected downstream of the control during both the filling and draining portions of each test on timed intervals.

The analysis of total suspended solids was conducted according to the procedure described in *Standard Methods for the Examination of Water and Wastewater* (APHA, 1992), Appendix C. A mean influent TSS concentration (MIC) and a mean effluent TSS concentration (MEC) were determined for each test as volume-weighted averages of all influent and effluent samples. The TSS removal efficiency of the control for each test was determined by the following equation.

$$\text{TSS Removal Efficiency, } \zeta = \left\{ 1 - \left(\frac{\text{Mass}_{\text{out}}}{\text{Mass}_{\text{in}}} \right) \right\} \times 100\%$$

where Mass out, (g) = [MEC, (g/m³)] x [Volume of runoff through control, (m³)];

Mass in, (g) = [MIC, (g/m³)] x [Volume of runoff into flume, (m³)].

N.B. mg/L = g/m³

Runoff remained in the flume more than 48 hours in many of the tests with silt fences at low flow rates. This time was chosen as the arbitrary cut off to end the test. The TSS concentrations after 48 hours were typically near zero; therefore, samples taken after 48 hours had no effect on calculated TSS removal efficiencies.

5.1.4 Base Efficiency of Testing Apparatus

One flume test was conducted with no control device in the flume. The influent flow rate matched that of the slowest filling test in order to determine the highest removal expected from sedimentation in the testing apparatus itself. A TSS reduction of 34% was observed without any control in the flume. Hydraulic data and TSS removal efficiency calculations are presented in Appendix F.

Part of the solids removal efficiency was caused by sedimentation and not entrapment in the controls. Some settling of the suspended particles occurred as the runoff passed from the highly agitated mixing tank to the relatively quiescent flume. This

phenomenon is similar to sediment-laden runoff flowing down a slope in the field at a high velocity. Sediment is deposited at the toe of the slope when the slope gradient and runoff velocity decrease.

5.1.5 Description of Tested Controls

The change in efficiency over time was observed by running a series of tests through the same control. Four types of silt fences and a rock berm were subjected to cycles of simulated runoff events. The silt fences tested were constructed of geotextile fabrics. Properties of the fabrics as reported by the manufacturers are summarized in Table 5.4.

Table 5.4 Tested Silt Fence Fabric Properties

Type of Fabric	AOS, # sieve size(μm)	Permittivity, sec^{-1}	No. of Tests
Belton woven	#30 (600)	0.4	9
Exxon woven	#30 (600)	0.1	5
Mirafi non-woven	#100 (150)	1.5	5
Amoco woven	#20 (850)	0.2	5

An attempt was made to determine the percent open area (POA) of the woven fabrics tested. The percent open area measures the percent of total fabric area that can pass water, while apparent opening size measures the size of the openings. Information on these characteristics would allow calculation of actual flow velocities through the fabrics.

Specimens of all the woven silt fence fabrics were scanned and copied on a microfiche reader; however, only the Amoco 2125 fabric had well defined openings. The magnified pore openings were measured and the area of voids calculated. Three scans of the fabric were made on a bias across the specimen so that no one warp or weave would appear on another scan. The average percent open area for three scans of that fabric was 3.3%.

A rock berm also was tested for sediment removal efficiency. TxDOT specifications were followed in the construction of a Type I unreinforced rock berm,

which is the most common type of berm used on construction sites. A cross-section view of the flume and Type I berm used in the testing is illustrated in Figure 5.3.

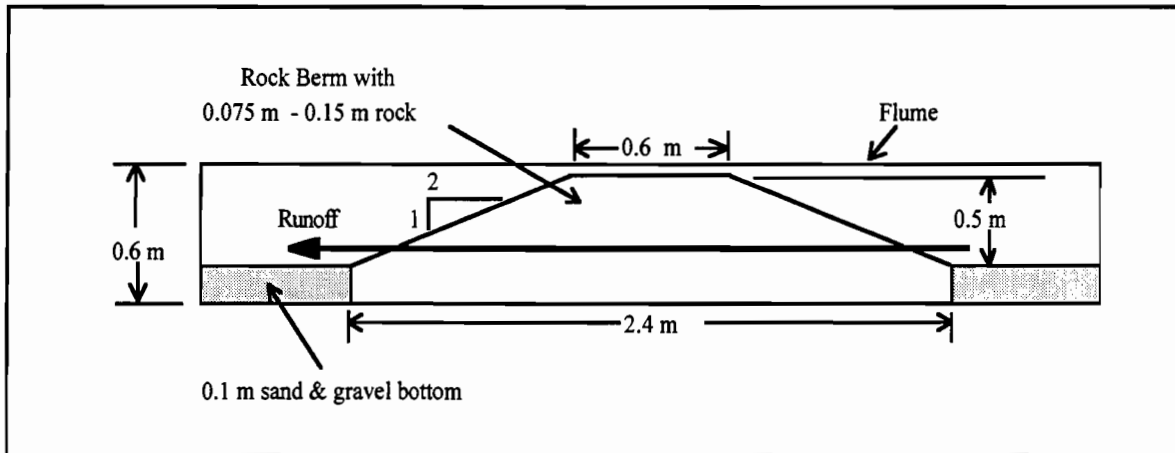

Figure 5.3 Section of Flume and Rock Berm Cross-Section

5.1.6 Hydraulic Behavior of Sediment Controls in the Flume

The water level upstream of the controls was monitored for the duration of each flume test. Changes in the level of the ponded water surface were converted into volumes of runoff passing through the sediment control in a given time interval. In the filling portion of the test, the incremental volumes flowing out of the control were calculated as the difference between the volume of runoff going into the flume and the change in volume within the flume over that time interval. Occasionally, calculated values of these volumes were negative. The accuracy of measuring the smaller effluent flow rates are overwhelmed at times by inaccuracies in the measurements of the larger influent flow rates.

A volume of runoff in the flume at a time t_1 during the drainage portion of a test is illustrated in Figure 5.4. The depth of the simulated runoff is denoted by h_1 . The flume has a constant width and surface area, w and A_s , respectively. The head in the ponded

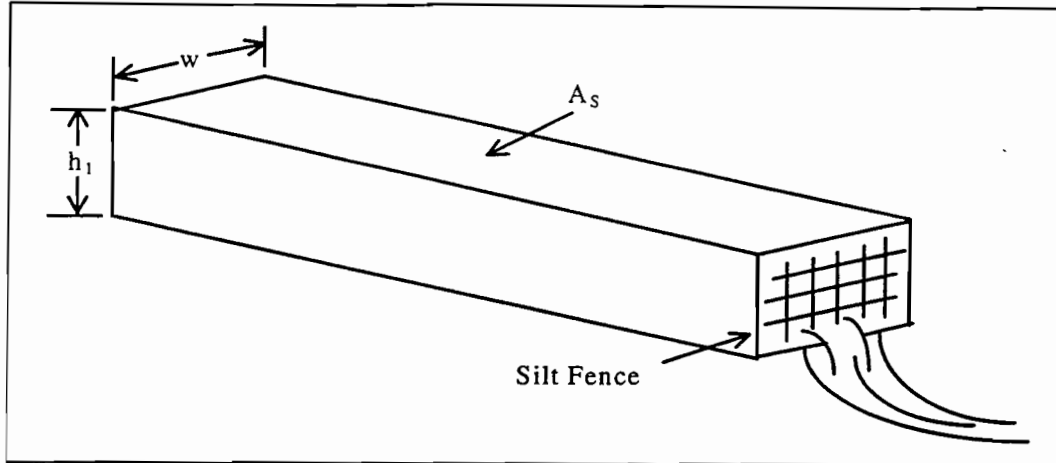

Figure 5.4 Volumetric Changes in Runoff Trapped Upstream of Silt Fence

runoff is equal to h_1 . The head downstream of the silt fence is assumed to be zero. Therefore, the change in head across the fabric is equal to h_1 . At a later time, t_2 , the level of the runoff is h_2 . The volume of runoff passing through the geotextile in this time interval is ΔV .

$$\Delta V = (h_1 - h_2)A_s$$

These volumes were used to calculate a detention time, effluent suspended solids load, and TSS removal efficiency for each test. These calculations are provided in Appendix D. The flow-through rate, q , during this interval is the volume divided by the time interval and submerged area of fabric (width of fabric times average level during interval).

$$q = \Delta V / [(t_2 - t_1) \left(\frac{h_1 + h_2}{2} \right) w]$$

Flow rates observed in the flume tests are approximately two orders of magnitude less than the values stated by the manufacturers (Table 5.5). Recommended flow rates of $0.2 \text{ L/s}\cdot\text{m}^2$ (Wyant, 1981) appear to reflect actual performance better than many used in current practice, including the TxDOT (1992) recommendation of $27 \text{ L/s}\cdot\text{m}^2$. Much of

the difference between measured and predicted flow rates is caused by sediment clogging the fabric openings.

The woven Mirafi fabric exhibited such clogging after a series of tests with clean water (probably from scour of the sand). In subsequent flume tests the fabric behaved as if it were clogged from the beginning. This sample was designated Mirafi A and another sample, Mirafi B, was placed in the flume in order to observe the performance of clean fabric. The flow rates given for the Mirafi fabric in Table 5.5 are those of the B sample.

Runoff did not flow through approximately 2 cm of the upper portion of the silt fence fabrics during the tests. This behavior also was noticed by Crebbin (1988) in his experiments.

Table 5.5 Flow per Area of Silt Fence (L/s·m²) as a Function of Head

Head, m	Belton w	Exxon w	Mirafi B nw	Amoco w
0.15	2.4	0.38	0.39	5.8
0.30	5.5	0.82	NA	NA

The hydraulic behavior of the rock berm in all of the flume tests was practically identical, indicating that there was no clogging. A steady state level was maintained by the rock berm for all five tests at the maximum possible flow rate in the flume (90 L/s·m²). The average steady state level was 0.06 m. Approximately 0.4 m of rock berm was not submerged. TxDOT (1992a) recommends a maximum flow rate of 40 L/s·m², which is greatly exceeded in berms constructed according to the TxDOT design criteria.

5.1.7 Determining Detention Times for Flume Tests

Detention times were calculated for each test of the silt fences and rock berm and are provided in Appendix D. An average detention time, T_{avg} , was determined for each ΔV of runoff passing through the controls. A volume-weighted detention time, T_d , for each test was calculated by:

$$T_d = \frac{\sum T_{avg} * \Delta V}{\sum \Delta V}$$

Many of the tests ended after 48 hours; however, in some cases the runoff had not completely drained through the silt fence fabrics. The relationship of the runoff level with respect to time for the last 24 hours of the test can be approximated by a linear function. The time for the flume to drain completely was estimated by extrapolating linearly from the last few data points. A typical test where runoff remained in the flume even after 48 hours and the estimated time of complete drainage is presented in Figure 5.5.

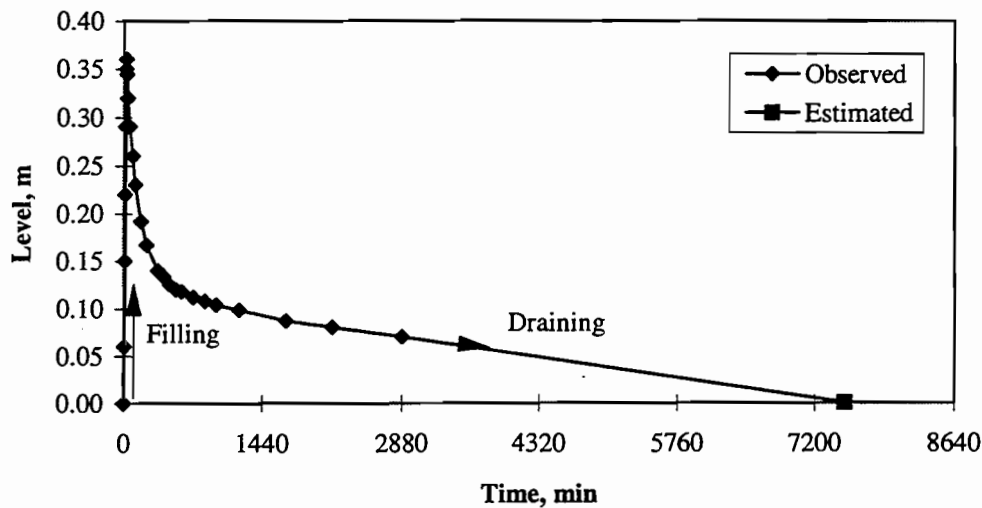

Figure 5.5 Observed Levels During a Flume Test and the Extrapolated Time for Complete Drainage

5.1.8 TSS Removal Efficiency

The observed TSS removal efficiency range, mean, median, and standard deviation for each silt fence are presented in Table 5.6. Individual test results are given in Appendix D. Removal efficiencies were based on influent and effluent suspended solids mass loads. Calculations of these removal efficiencies also are provided in Appendix D.

The highest removal efficiencies were observed for the non-woven Mirafi fabric. This fabric also had the lowest flow rates of the fabrics tested. Increased detention time for the suspended solids behind the silt fence lead to increased removal efficiency.

Conversely, the woven Amoco fabric had the lowest TSS removal efficiencies and the shortest detention times.

The detention times plotted against the TSS removal efficiency for each test are presented in Figure 5.6. A correlation between T_d and TSS removal efficiency is apparent. Lower flow rates results in increased detention times and increased solids removal efficiency.

Table 5.6 TSS Removal Efficiencies, %

Control	Mean	Median	Std. Dev.	Range
Belton w	70	72	13	46-82
Exxon w	90	87	6	84-97
Mirafi nw	90	93	11	73-99
Amoco w	68	68	3	65-73
Rock Berm	42	42	7	36-49

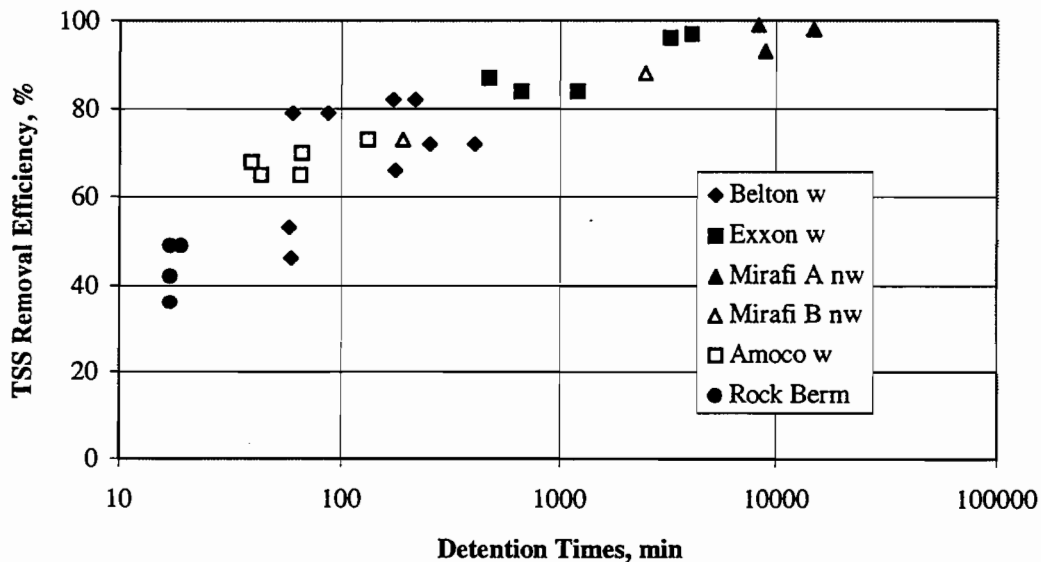

Figure 5.6 TSS Removal Efficiency as a Function of Detention Time

The longest detention times in this series of tests were observed for the Mirafi A fabric even though this fabric had the highest reported permittivity (Table 5.4). This fabric also had the smallest apparent opening size, suggesting that clogging of the fabric with sediment was responsible for the unexpected hydraulic performance. This

observation demonstrates that field performance can not be determined from current parameters used to characterize the hydraulic properties of these fabrics.

The mean removal efficiency of the rock berm, when the removal efficiency of the flume itself is subtracted, was approximately 7%. This removal efficiency is similar to reports of sediment trapping efficiency for rock berms in the field (Reed, 1980; Weber and Wilson, 1976). The influent flow rate for the rock berm was the highest used in the tests and should have caused the TSS removal efficiency of the flume itself to be a minimum; therefore, the 7 % efficiency is a minimum value.

5.1.9 Effects of Sediment Clogging and Rainfall Washing

The detention times for each test with respect to the time of testing are presented in Figure 5.7. The rainfall data from a nearby monitoring station also are plotted. When the *series* of tests of an individual silt fence are compared, subsequent tests show an increase in the detention time. This phenomenon is likely caused by sediment

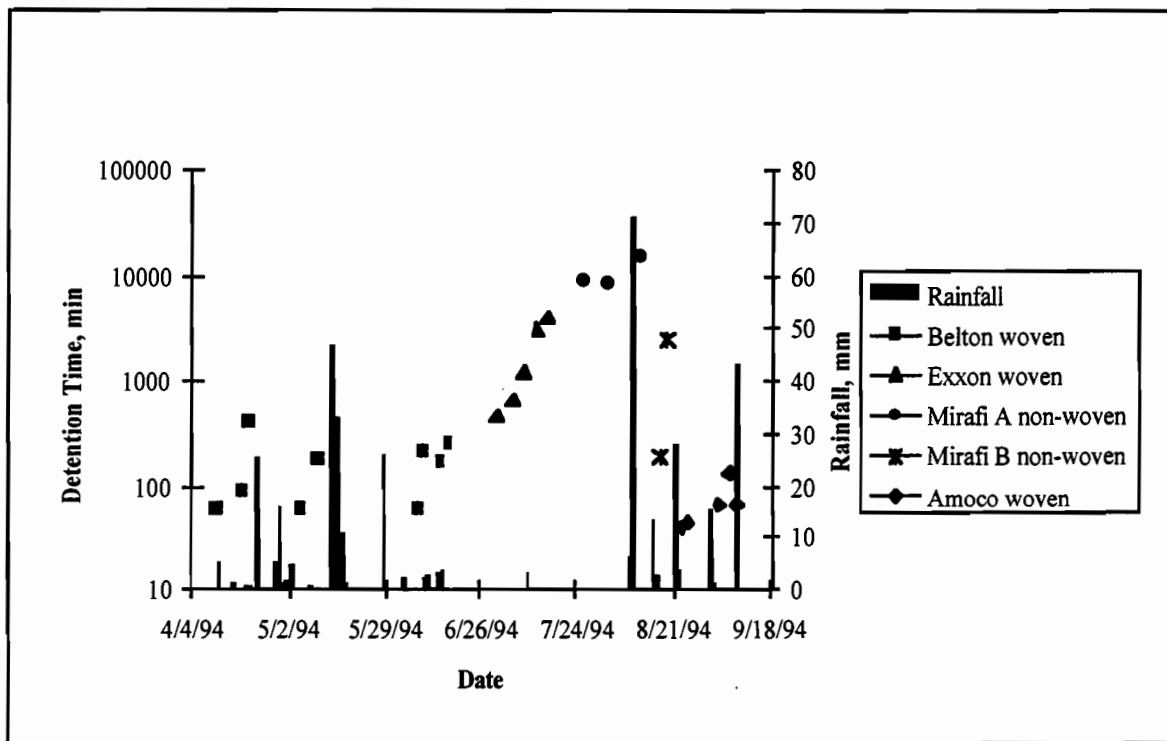

Figure 5.7 Detention Times as a Function of Testing Schedule

accumulating in the fabric. In the field, this clogging effect may be more pronounced because of construction and traffic debris (grass, paper, plastic, etc.). Tests on woven

fabrics that were run without a major rainfall event occurring in the interval all show this behavior.

It is noteworthy that after major rainfall events, detention times decreased for the woven fabrics. This observation suggests that sediment accumulated in the woven silt fence fabrics could have been washed off resulting in increased flow rates. The woven Belton fabric exhibited detention times on May 4 and June 7th quite similar to the initial detention time observed on April 11. This washing of the fabric may also occur in the field when rainfall precedes the ponding of runoff. Rainfall did not appear to have an effect on the non-woven fabric (August 8). Non-woven fabrics appear to have retained more of the trapped sediment in the three-dimensional structure and, therefore, the washing of the fabric by the rainfall does not occur.

The non-woven fabric had the highest reported manufacturers permittivity, which indicates short detention times, but this fabric had the longest measured detention times of all the controls tested. Clogging was more of a factor in the non-woven because of the three dimensional construction of the fabric. Woven fabrics have a more two-dimensional profile and are prone to clogging, but to a lesser extent than non-woven fabrics.

5.2 Permeameter Tests

Samples of silt fence fabric were subjected to constant head permeability tests because of the extremely low flow rates observed in the flume tests. Permeameter tests permitted a greater insight into the hydraulic behavior of silt fence fabrics than the flume tests. The relationship between head and flow rates was more apparent because constant heads were used and a wider range of heads were possible.

5.2.1 Methodology

Three samples were chosen from the fabrics tested in the flume. A modified soil permeameter allowed the flow rates to be determined for heads of 0.05, 0.1, 0.2, 0.3, 0.4, 0.5, and 0.6 m. ASTM D 4491 (1992) is run at a head of 0.05 m. Silt fences in the field could experience heads of up to 0.6 m.

The permeameter initially was set up to run constant head tests with a Marriot tube. The first trial tests with silt fence fabric in lieu of a column of soil proved to drain too rapidly. The flow through the fabric was so turbulent and rapid that errors in timing the test were overwhelming. This situation was remedied by the fabrication of two stainless steel plates that reduced diameter of the specimen from 15.2 cm to 2.54 cm. The column was modified by disconnecting the Marriot tube and installing a water supply controlled by a needle valve. These modifications allowed a fine adjustment of the flow rates and facilitated maintaining a constant head during the tests. The modified soil permeameter with filter fabric specimen installed is illustrated in Figure 5.8.

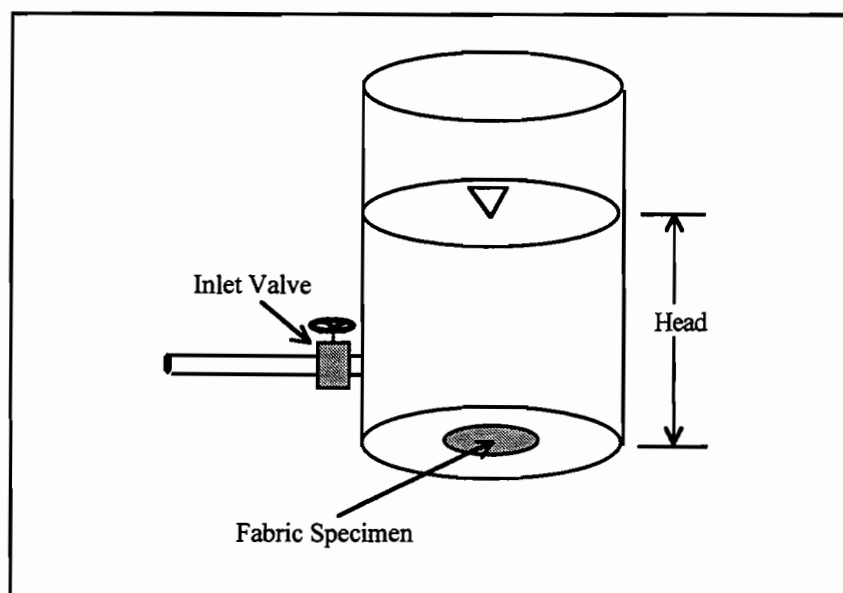

Figure 5.8 Modified Soil Permeameter

During a test the valve was adjusted until a steady state flow rate was achieved at the specified head. A container of known volume was placed beneath the discharge from the column and the time required to fill the container was recorded. Effects of entrained air on flow through a geotextile were determined by using two sets of tests. In one test, the air was removed from the fabrics by applying a vacuum before each change in head. Water was drawn through the fabric prior to the test with a hose connected to a vacuum flask to remove any trapped air from the fabric. In the other test the samples were not vacuumed.

Two tests were run for each of three fabric samples; i.e., with and without application of a vacuum to the fabric specimens. Constant heads varied from 0.05-0.6 m.

5.2.2 Results of Permeameter Tests

The observed flow rates and a calculated permittivities at each head for the three fabric samples are presented in Appendix E. The permittivities (Ψ) observed in the tests at heads of 0.05 m were the same order of magnitude but slightly greater than the permittivities reported by the manufacturers (see Table 5.7). This observation may be due to systematic differences between the permeameter test and ASTM D 4491.

Table 5.7 Comparison of Ψ for 3 Fabrics Using ASTM D 4491 and a Permeameter (h = 0.05 m)

Fabrics (not vacuumed)	ASTM D 4491 Ψ , sec ⁻¹	Permeameter Ψ , sec ⁻¹
Mirafi non-woven	1.5	2.1
Amoco woven	0.2	0.36
Belton woven	0.4	0.67

Eliminating entrapped air appeared to have no consistent effect on flow rates through the fabrics. The flow rates for the non-woven Mirafi and the woven Belton were greater without eliminating entrapped air. The lower fabric permittivities observed in the flume do not appear to be caused by air trapped in the fabric.

A typical plot of flow rate versus head is presented in Figure 5.9. These data demonstrate a nonlinear relationship between flow and head. The best-fit equations relating flow to head show that the flow is a power function of the head with exponents ranging from 0.46 to 0.71.

The ASTM method assumes that flow is laminar (i.e. viscous effects dominate); therefore, the flow rate should be a linear function of the head (exponent equal to 1). If inertial forces dominate (turbulent flow), the flow rate should be a function of the square

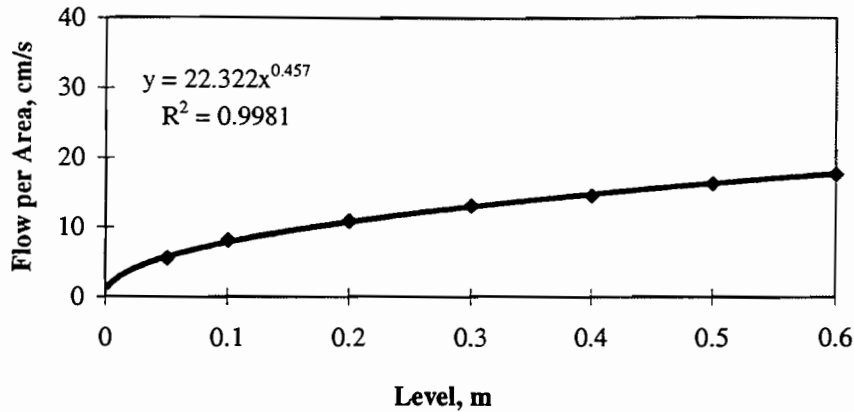

Figure 5.9 Flow vs. Head for Belton Woven Fabric (not vacuumed)

root of the head. The data observed for the permeameter tests show that the actual drainage behavior lies somewhere between these two cases. At the low heads used in ASTM D 4491, 10-75 mm, the relationship between flow rate and head could be approximated by a linear function.

The velocity through the fabric during the permeameter test was calculated using the Amoco 2125 (3.3% open area), the fabric specimen area, and the permeameter flow rate. This velocity and a pore diameter (AOS = 850 μm), were used to calculate the Reynolds numbers shown in Table 5.8.

Table 5.8 Velocities and Reynolds Number for Flow Through Amoco Woven Fabric

Head, m	Q/A, cm/s	Velocity, m/s	Re
0.05	1.8	0.54	459
0.1	3.2	1.0	825
0.2	4.8	1.4	1,230
0.3	5.2	1.9	1,610
0.4	7.2	2.2	1,860
0.5	8.0	2.4	2,060
0.6	8.7	2.6	2,230

The transition from laminar flow occurs in subsurface flow when the Reynolds number exceeds 10 and in pipe flow when the Reynolds number exceeds 2,000. Turbulent flow through a geotextile will occur when the Reynolds number is between

these two values. The flow through this particular geotextile is turbulent at the high end of the range of heads tested. The definition of permittivity described in ASTM D 4491 assumes laminar flow and, therefore, does not apply for higher heads.

The results of the permeameter tests show that the relationship between the head and flow is not a linear function. Flow through at least one of the fabrics is definitely turbulent. These results show that ASTM permittivity is not appropriate for predicting the hydraulic performance of geotextiles when they are used as silt fence fabrics.

6. CONCLUSIONS AND RECOMMENDATIONS

The inventory of temporary runoff controls on TxDOT construction sites indicated that silt fences and rock berms were the most commonly used runoff controls on construction sites. Rock berms were used to treat the drainage from 53% of the area of the six sites in the study area. Silt fences and sedimentation ponds were the next most common runoff controls treating 23% and 22% of the total area, respectively. Sediment ponds were the most inexpensive control on a cost per area basis and were used more frequently in the earlier stages of construction. Erosion control blankets were the most expensive controls and tended to be used in the later phases of construction.

Field evaluation of the efficiency of silt fences in removing sediment in runoff from highway construction runoff showed that the median removal due to filtration was 0%. Additional removal occurred due to particle settling, but was not quantified in the field portion of the study. The median concentration of solids discharged from the silt fence controls was approximately 500 mg/L. Geotextile silt fences also proved to be ineffective in reducing turbidity. The median turbidity reductions for the sites monitored was about 2%. Monitoring of a single rock berm also showed negligible TSS removal.

The poor filtration performance of the geotextile fabrics alone indicates the disparity between test efficiency and actual field performance. The bulk of the difference could be credited to an unrealistic particle size distribution in the slurry mixtures of previous laboratory studies. Silt and clay size particles were the primary constituents of construction site generated sediment in this study. The observed data indicated that silt and clay size particles comprised 92% of the total suspended solids.

The field efficiency of silt fences appears to be dependent mainly on the detention time of the runoff behind the control. The detention time is controlled by the geometry of the upstream pond, hydraulic properties of the fabric, and maintenance of the control. Despite comments by project supervisors that little maintenance of controls was required, numerous installation and maintenance deficiencies were noted during the study. Holes in the fabric and inadequate “toe-ins” that result in under-runs reduced the detention time available for particle settling. In addition, the openings released the discharge in a

concentrated flow which promoted erosion below the structure and resulted in short circuiting in the ponded area.

In contrast to the field monitoring, high removal efficiencies were achieved with silt fences in the flume studies. The geometry of the flume created a large ponded area behind the controls resulting in long detention times and significant particle settling even with the fine-grained sediment used in the tests. Mean sediment removal efficiency in the flume ranged from 68 to 90% and was highly correlated with the detention time of the runoff. This indicates that silt fences should be sited in the field so as to maximize the ponded volume behind the fence.

Sediment-laden runoff flow rates through the controls were two orders of magnitude less than those typically specified by transportation agencies. The flow rates of a sediment slurry through geotextile fences are a function of apparent opening size as well as permittivity (or other measures of clean water flowrates). The fabric resulting in the longest detention times in this series of flume tests had the highest reported permittivity, but it also had the smallest apparent opening size, suggesting that clogging of the fabric with sediment affected its hydraulic performance. Field performance can not be determined from current parameters used to characterize the hydraulic properties of these fabrics.

In addition, tests of silt fence fabrics in a modified permeameter showed that flowrates through the fabric were not linearly related to head as is assumed in the ASTM definition. The discrepancy was due to the fact that flow at the heads fabrics are subjected to in silt fence applications is turbulent resulting in much lower flow rates. Permeameter tests of silt fence fabrics confirmed that entrapped air is not the cause of the much lower flowrates.

Flowrates through rock berms greatly exceeded the rates typically recommended in regulatory agency guidelines. The short detention times and large pore size of the berms resulted in only a slight reduction in the suspended solids load in the flume tests.

Development of a new test or series of tests to characterize the expected performance of geotextile fabrics when used as silt fences is urgently needed. The use of current parameters results in an over-estimate of the area that can be treated without over-

topping. Knowledge of the performance under field conditions would allow the development of rational guidelines governing the placement of these controls. Testing of fabrics using sediment size distributions of construction site sediment yield should serve as the foundation for future studies.

7. BIBLIOGRAPHY

American Public Health Association et al., 1992, "Standard Methods for the Examination of Water and Wastewater," American Public Health Association, Washington D.C.

American Society for Testing and Materials (ASTM), 1993, "D 4751 Standard Test Method for Determining Apparent Opening Size of a Geotextile."

ASTM, 1992, "D 4491 Standard Test Method for Water Permeability of Geotextile by Permittivity."

ASTM, 1987a, "D 4751-87 Standard Test Method for Determining Apparent Opening Size of a Geotextile," *Annual Book of ASTM Standards* Vol. 4.08, American Society for Testing and Materials.

ASTM, 1987b, "D 4632-86 Standard Test Method for Breaking Load and Elongation of Geotextiles," *Annual Book of ASTM Standards* Vol. 4.08, American Society for Testing and Materials.

ASTM, 1987c, "D 4491-85 Standard Test Method for Water Permeability of Geotextile by Permittivity," *Annual Book of ASTM Standards* Vol. 4.08, American Society for Testing and Materials.

Bell, J.R. and R.G. Hicks, 1984, "Evaluation of Test Methods and Use Criteria for Geotechnical Fabrics in Highway Applications," Final Report, FHWA, Contract No. DOT-FH-119353. Oregon State University, Corvallis, Oregon.

Chang, G., 1994, "Personal Interview," Engineer, City of Austin Environmental and Conservation Department.

Crafton, C. S., 1987, "Performance Criteria for Erosion and Sediment Control," Erosion Control You're Gambling Without It, Proceedings of Conference XVIII International Erosion Control Association Held in Reno, Nevada 26-27 February 1987, International Erosion Control Association, Pinole, California.

Crebbin, C., 1988, "Laboratory Evaluation of Geotextile Performance in Silt Fence Applications Using a Subsoil of Glacial Origin," Master's Report, University of Washington.

Dallaire, G., 1976, "Filter Fabrics: Bright Future in Road and Highway Construction," *Civil Engineering-ASCE*, pp 61-65.

Das, B. M., 1985, "Principles of Geotechnical Engineering," PWS Publishers, Boston, Massachusetts.

Daugherty, R. L., et al., 1985, "Fluid Mechanics with Engineering Applications," 8th Edition, McGraw-Hill Book Company, NY.

Dowell, J., 1987, "Erosion Control Products: Making the Right Choice," Public Works, p 46.

Environmental Protection Agency (EPA), 1992, "Storm Water Management for Construction Activities, Developing Pollution Prevention Plans and Best Management Practices," Office of Wastewater Enforcement and Compliance, Washington D.C.

Gervais, F. A. and D. E. Piercey, 1988, "Construction Through Delicate Ecosystems," Nova Scotia Department of Transportation and Communications Publication, Windsor Junction, Nova Scotia.

Goldman, S. J., Jackson, Katherine, and Bursztynsky, Taras A., 1986, "Erosion and Sediment Control Handbook," McGraw-Hill, Inc., NY.

Highway Research Board, 1973, "Erosion Control on Highway Construction," National Research Council, National Academy of Sciences.

Hittman Associates, Inc., 1976, "Methods to Control Fine Grained Sediments Resulting from Construction Activity," WA-RD 200.1, Washington D.C.: Environmental Protection Agency, Office of Water Planning and Standards.

Horner, R. R., Guedry, J., and Korten Hof, M. H., 1990, "Improving the Cost Effectiveness of Highway Construction Site Erosion and Pollution Control," Washington State Transportation Center, Washington State Department of Transportation, Seattle, Washington.

King County Department of Public Works, 1990, "Surface Water Design Manual," King County Department of Public Works.

Koerner, R. M., and Welch, J. P., 1980, "Construction and Geotechnical Engineering using Synthetic Fabrics," Wiley and Sons, Inc.

Koerner, R. M., 1984, "Construction and Geotechnical Methods in Foundation Engineering," McGraw-Hill Book Company, NY.

Koerner, R. M., 1990, "Designing with Geosynthetics," Prentice Hall, Englewood Cliffs, NJ.

Kouwen, N., 1990, "Silt Fences to Control Sediment Movement on Construction Sites, MAT-90-03," The Research and Development Branch Ontario Ministry of Transportation.

Kulzer, L., 1988, "Considerations for Using Geotextiles in Silt Fence Applications," Metro Technology Publication, Seattle Washington.

Martin, J. S., 1985, "Use of Silt Fences for Control of Sediment Runoff," Erosion Control: A Challenge in Our Time, Proceedings of Conference XVI International Erosion Control Association Held in San Francisco, California, 21-22 February 1985, International Erosion Control Association, Pinole, California.

McCoy, T. G., 1993, "An Evaluation of the In-Field Performance and Efficiency of Geotextile Silt Fences for Highway Construction Projects in Austin, TX," M.S. Thesis, The University of Texas at Austin.

Metcalf & Eddy, Inc., 1991, Wastewater Engineering: Treatment, Disposal, and Reuse, McGraw-Hill, Inc., New York.

Montgomery Consulting Engineers, Inc., 1985, "Water Treatment Principles and Design", John Wiley & Sons, NY.

Nawrocki, M. and Pietrzak, J., 1976, "Methods to Control Fine-grained Sediments Resulting from Construction Activity, EPA 440/9-76-026," USEPA, Office of Water Planning and Standards, Washington D.C.

North Central Council of Governments, 1993, "Storm Water Quality Best Management Practices for Construction Activities."

Reed, L., 1978, "Suspended-Sediment Discharge, in Five Streams near Harrisburg, Pennsylvania, Before, During, and After Highway Construction," Geological Survey Water-Supply Paper 2072, U.S. Government Printing Office, Washington D.C.

Rollin, A. L. 1986, "Filtration Opening Size of Geotextiles," ASTM Standardization News, pp 50-53.

Schueler, T. R. and Lugbill J., 1990, "Performance of Current Sediment Control Measures at Construction Sites," Metropolitan Washington Council of Governments, Sediment and Stormwater Administration of Maryland Department of the Environment.

Smoot, J.T., Moore, T.D., 1992, Deatherage, J.H., and Tschantz, B.A., "Reducing Nonpoint Source Water Pollution by Preventing Soil Erosion and Controlling Sediment on Construction Sites," Transportation Center, University of Tennessee.

Soil Conservation Service (SCS), 1974, "Soil Survey of Travis County," US Department of Agriculture in cooperation with the Texas Agricultural Experimental Station.

Suits, D. L., 1986, "Geotextile Permeability and Filtration," ASTM Standardization News, May, pp 46-49.

Swerdon, P. M. and Kountz, R. R., 1973, "Sediment Runoff Control at Highway Construction Sites," Engineering Research Bulletin, B-108, pp 1-45.

Teamah, J. A., 1993, "An Investigation of Woven and Nonwoven Geotextiles in Silt Fence, Publication 3-J-3-158," Texas Department of Transportation.

Texas Department of Transportation (TxDOT), 1992a, "National Pollutant Discharge Elimination System, Guidelines for Compliance with the General Permit for Construction Activities," TxDOT.

TxDOT, 1992b, "Departmental Materials Specification D-9-6230," TxDOT.

TxDOT, 1992c, "Special Specification Item 5797, Temporary Sediment Control Fence," TxDOT.

Weber, W. G. and Wilson, C., 1976, "Evaluation of Sediment Control Dams," Pennsylvania Department of Transportation, Bureau of Materials, Testing, and Research.

World Construction, 1986, "Geotextiles' Construction Role Grows Rapidly," pp 41-46.

Wyant, D. C., 1993, "Developing VTM-51 into an ASTM Test Method," Virginia Transportation Research Council, Virginia Department of Transportation, and Federal Highway Administration, FHWA/VA-94-R2.

Wyant, D. C., 1981, "Evaluation of Filter Fabrics for Use in Silt Fences," Transportation Research Record 832, pp 6-12.

Younkin, L. M. and G. B. Connelly. 1981, "Prediction of Storm-Induced Sediment Yield from Highway Construction," Transportation Research Record, 832, pp 1-5.

APPENDIX A - Sample Descriptions and Locations

Sample Descriptions

Samples T1-T30

Preliminary samples T1-T30 were collected in paired sets to assess instantaneous filtration efficiency for a specific study application. The individual upstream samples for the set T1-T12 were collected near the fabric at mid-range depths of retained flows. For site 1, minor downstream flow concentrations facilitated in-stream sample collections (see Figure A3 in Appendix A). For Sites 2 and 3, the downstream sample was carefully collected from the surface flow of the fabric adjacent to the upstream sample location (see Figures A4 and A5 in Appendix A). Sample T13 was collected after long term retention of an upstream pool to evaluate the effects of increased holding times.

Samples T15-T24 (see Figure A6 in Appendix A) and T25-T30 (see Figure A7 in Appendix A) of Site 1 were collected according to the original methodology. In these instances, the downstream flow concentration was minimal and the majority of downstream samples were collected at the face of the fabric.

Samples T31-T48

Samples T31-T48 were collected as multiple, individual, non-paired samples at various upstream and downstream locations in order to explore possible particle loading distributions. Samples T31-T42 of Site 4 (see Figure A8 in Appendix A) were collected at various locations within the upstream pond and various downstream locations along the internal walls of an uncovered inlet. During this collection opportunity at Site 4, the upstream retention was sheet-like in nature and ponding depths were minimal. Samples T43-T48 (see Figure A9 in Appendix A) were gathered in a similar fashion at site 1. Although multiple location sampling was not appropriate for the small downstream flow channel, three samples were taken at a single location to examine consistency. Individual samples were collected throughout the upstream pond.

Samples T49-T108

Samples T49-T108 were secured as multiple individual samples per stage per site. (Stage in this context refers to the category of sampling location.) In addition to the upstream pond stage, samples were collected in contributory flow concentrations adjacent to the upstream retention area to further explore overall efficiencies associated with the study installations. In order to differentiate samples collected in this manner, upstream contributory samples are designated with an upstream c descriptor, and samples collected from upstream ponds are designated with an upstream p descriptor in data and results tables.

Samples T49-T72 were collected similarly at Site 6. Multiple, individual samples were collected for each stage: upstream flow concentrations, upstream pond locations, and downstream locations. Since there were minor unfiltered flows from sources exterior to the system, downstream samples were gathered at the filter face. Sample groups T49-T60 (see Figure A10 in Appendix A) and T60-T72 (see Figure A11 in Appendix A) were collected from the same event at a time differential of approximately 1.5 hours so that changes resulting over time could be identified.

Samples T72-T84 (see Figure A12 in Appendix A) were collected at Site 3 according to the methodology described for the group. The majority of downstream samples were collected along the face of the fence, although a single sample was collected in a small flow concentration.

Samples T85-T96 (see Figure A13 in Appendix A) were collected in a similar fashion at Site 6. Unfiltered flows from external sources at the downstream stage were observed, and attempts to select and sample isolated in-stream locations were performed. Additional downstream samples were collected at the face of the fence. Over-topping resulting from large retention volumes precluded ordinary downstream sampling for set T97-T108 (see Figure A14 in Appendix A). In this case, samples were gathered from flows downstream in relation to a recently installed rock berm. Any samples attributed strictly to the operation of a rock berm are differentiated by the bolding of the sample descriptor in the data and results tables.

Samples T109-T122

Although samples T109-T122 were collected with the same basic methodology as described for set T49-T108, individual samples were mixed in the field (composited) to increase processing efficiency and reduce storage requirements. The downstream samples of set T109-T113 (see Figure A15 in Appendix A) were taken at the face of the fence at site 6. These samples were upstream in relation to a rock berm installation. Samples downstream of the berm were also collected for further evaluation. Upstream flow concentration samples were collected from the primary tributary flow and from a lesser influence flow concentration channel.

Over-topping precluded the collection of downstream samples in relation to silt fence 6 for set T109-T118 (see Figure A16 in Appendix A). Samples were collected for the evaluation of the rock berm filtration efficiency. Installation 7 was operating in tandem with system 6 and sample T115 was both an upstream flow concentration sample for Site 6 and a downstream sample for Site 7. There was no ponding associated with location 7, and the in-stream sample was the sole upstream representative.

The final sample set, T119-T122 (see Figure A17 in Appendix A), was collected under almost identical conditions and methods as the previous set; however, the upstream sample adjacent to the rock berm was inadvertently omitted.

Samples T1-T30 were evaluated individually to facilitate the comparison of TSS and turbidity for paired samples. Samples T30-T48 were unpaired samples evaluated individually for the examination of specific inferences. Frequent spring rainfalls and the addition of suspended particle size classification as the third parameter increased the work load and mandated a streamlining of the process. At that point in time, samples were composited to maximize efficiency and maintain the integrity of the study. Subsequently, samples T15-T108 were grouped according to site, time, event and date, and stage of flow for sample location:

Table A1. Source of Samples T15-T108

Composite Sample Number:	Individual Samples Combined:
TC1	T15,T17,T19,T21,&T23
TC2	T16,T18,T20,T22,&T24
TC3	T25,T27,&T29
TC4	T26,T28,&T30
TC5	T31,T32,T33,T34,T39,&T42
TC6	T35,T36,T37,T38,T40,&T41
TC7	T43,T45,&T47
TC8	T44,T46,&T48
TC9	T49,T50,T51,T52,T53,T54,&T55
TC10	T56,T57,&T58
TC11	T59 & T60
TC12	T61,T62,T63,T64,&T65
TC13	T66,T67,T68,&T69
TC14	T70,T71,&T72
TC15	T73,T74,&T75
TC16	T76,T77,T78,&T79
TC18	T80,T81,T82,T83,&T84
TC19	T85,T86,T87,T88,&T89
TC20	T90,T91,&T92
TC21	T93,T94,T95,&T96
TC22	T97,T98,T99,&T100
TC23	T101,T102,T103,&T104
TC24	T105,T106,T107,&T108.

As a further enhancement of efficiency and reduction of possible error, samples T109-T122 are the product of individual samples which were composited in the field. The

individual analyses of samples T1-T12 resulted in inadequate residual volumes for the analyses of a grouping. For these samples and others where conditions warranted, a numeric averaging of individual results was used for evaluation.

Table A2 Source of Samples T1-T12 and T43, T45, & T47

Average Sample Number:	Individual Sample Averaged:
TA1	T1 & T3
TA2	T2 & T4
TA3	T5 & T7
TA4	T6 & T8
TA5	T9 & T11
TA6	T10 & T12
TA7	T43, T45, & T47.

For samples TC1 through TC8, turbidity values for the respective individual samples were averaged in lieu of a composite analysis.

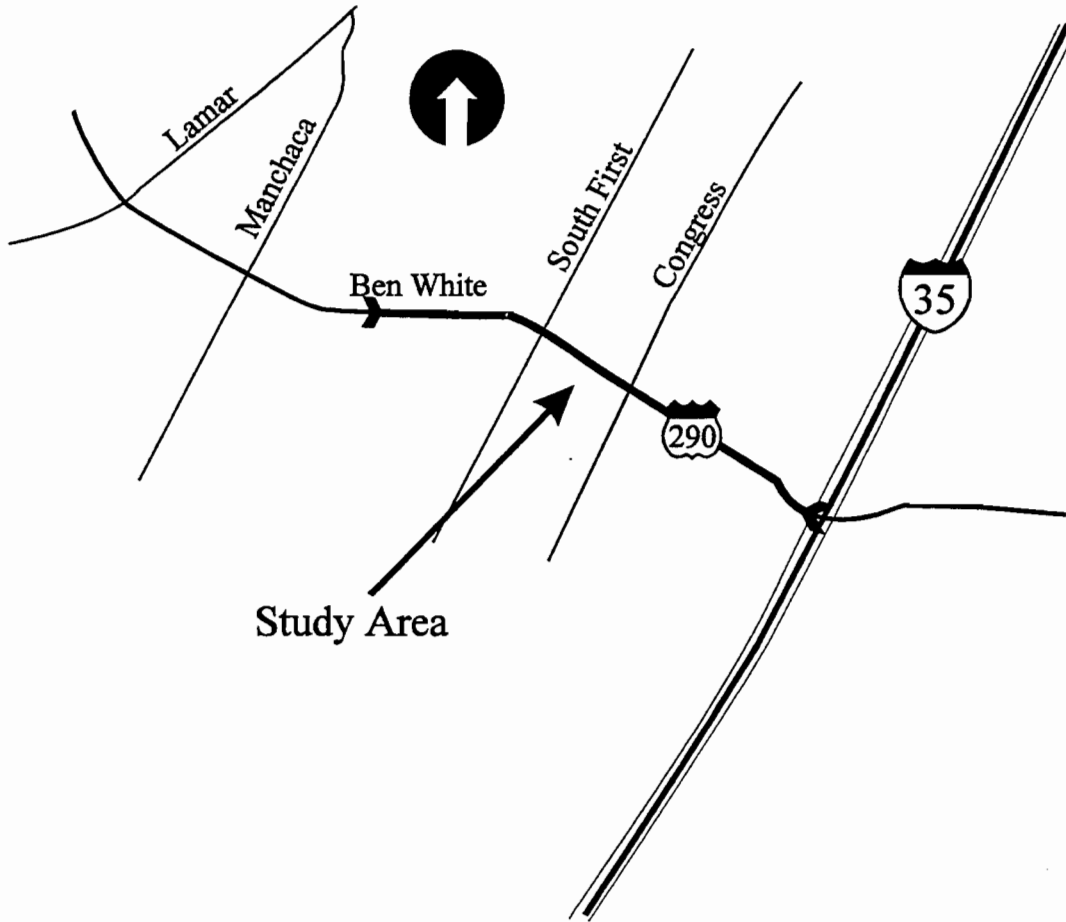

Figure A1 Construction Project Location

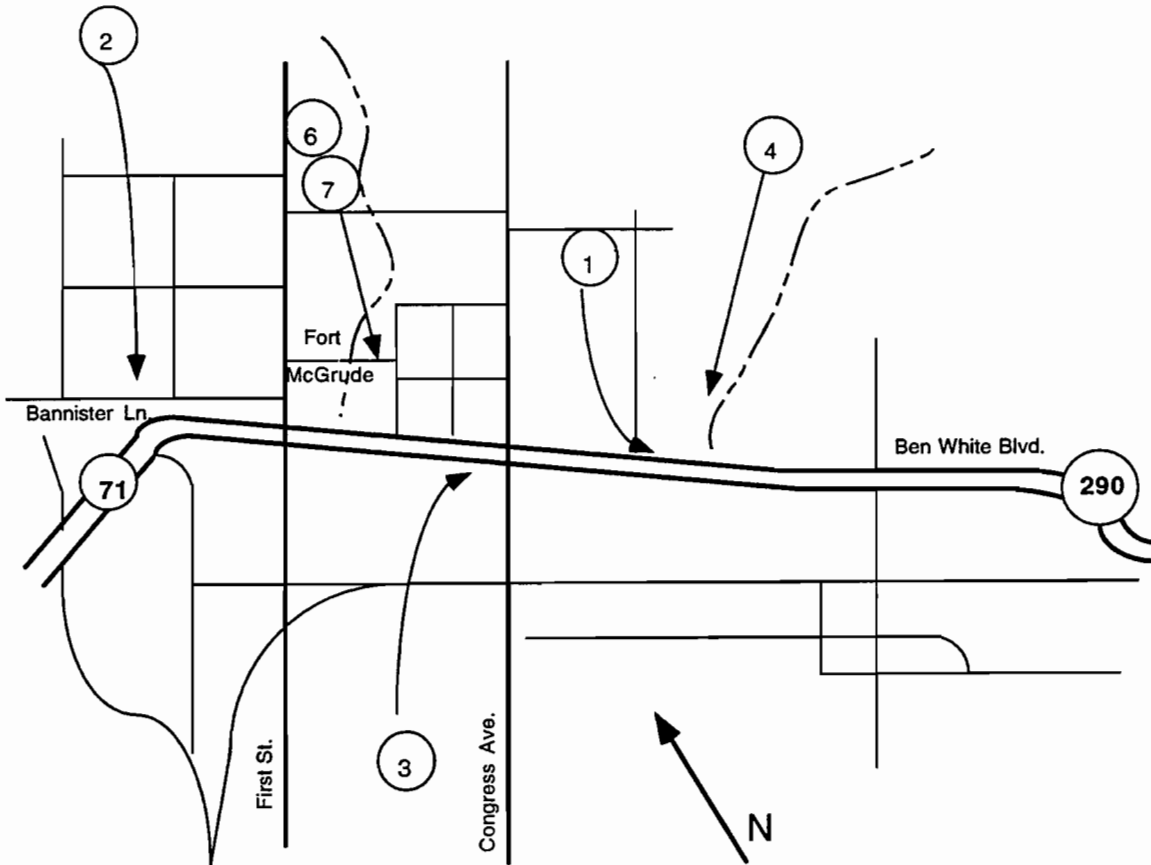

Figure A2 Silt Fence Locations

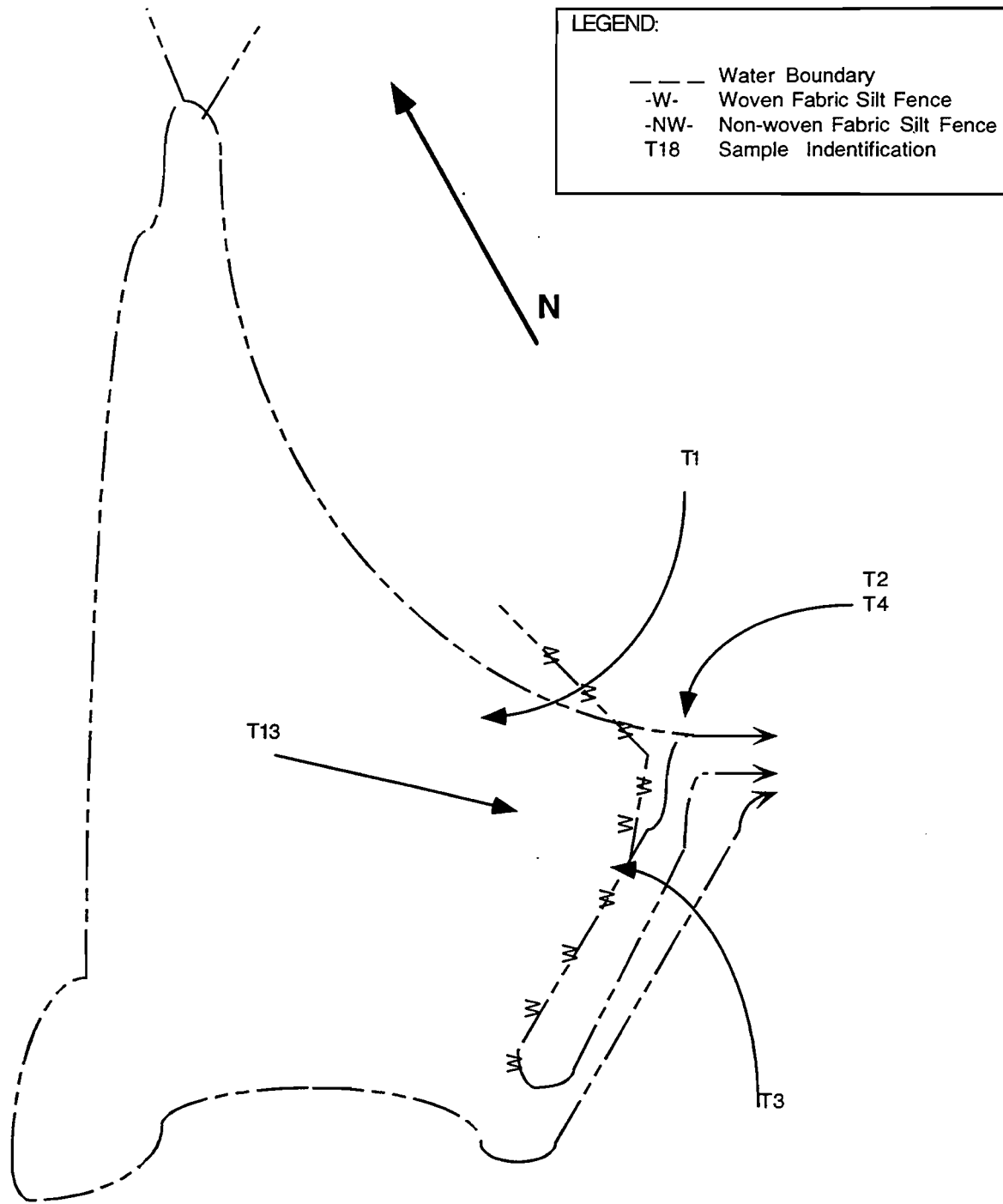
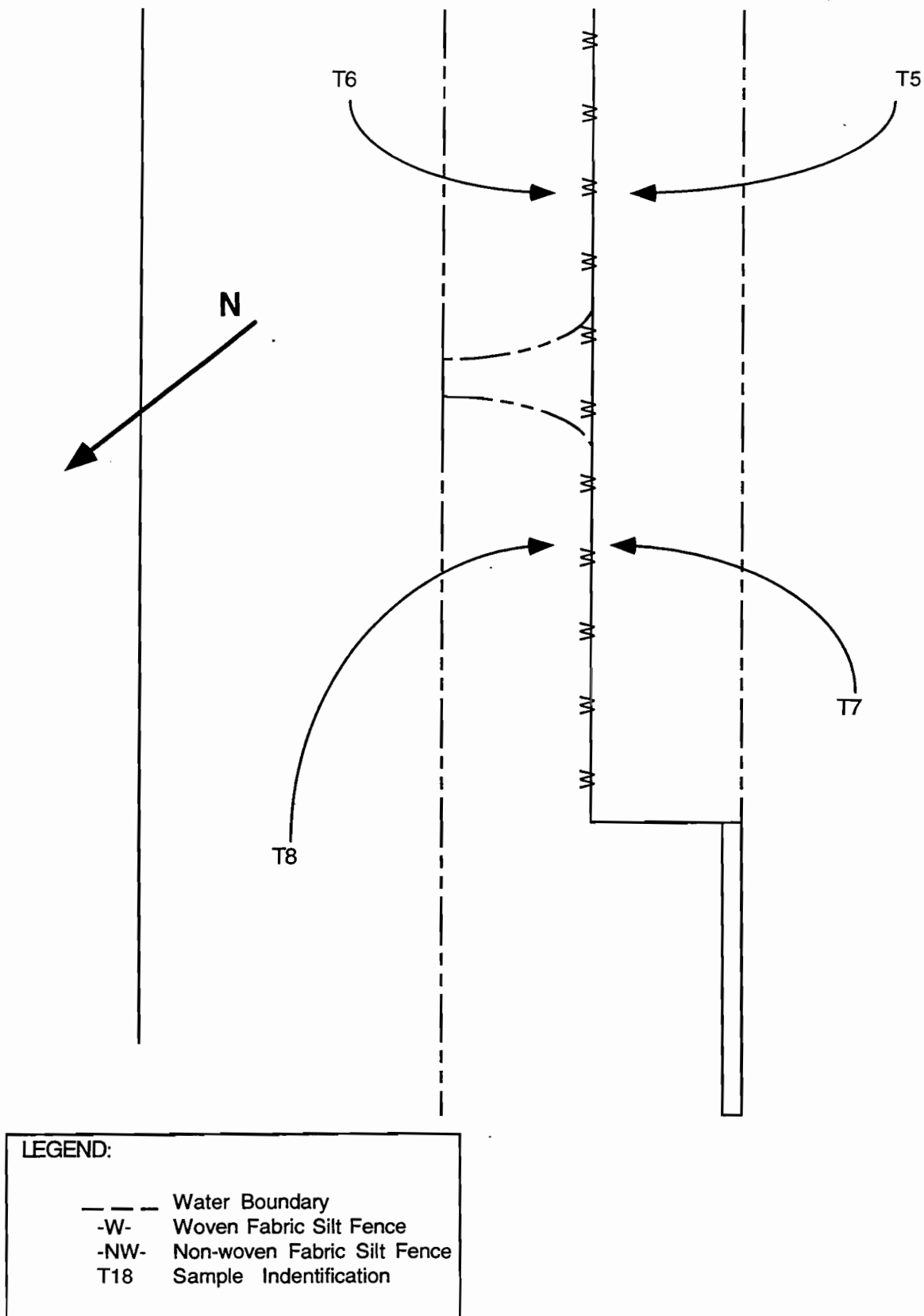

Figure A3 Sample Locations T1-T4, T113 (Site 1)



LEGEND:

- - - Water Boundary
- W- Woven Fabric Silt Fence
- NW- Non-woven Fabric Silt Fence
- T18 Sample Identification

Figure A4 Sample Locations T5-T8 (Site 2)

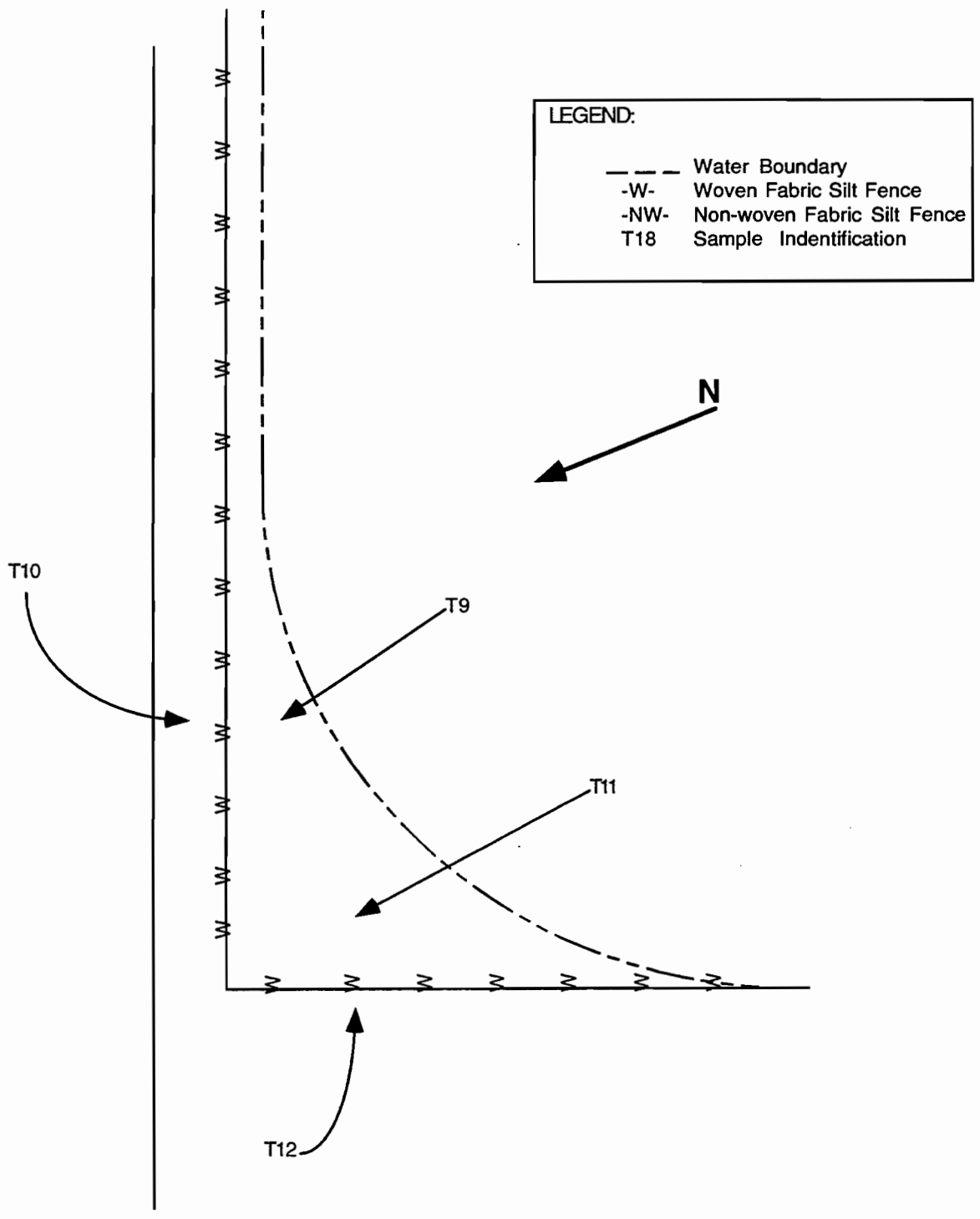

Figure A5 Sample Locations T9-T12 (Site 3)

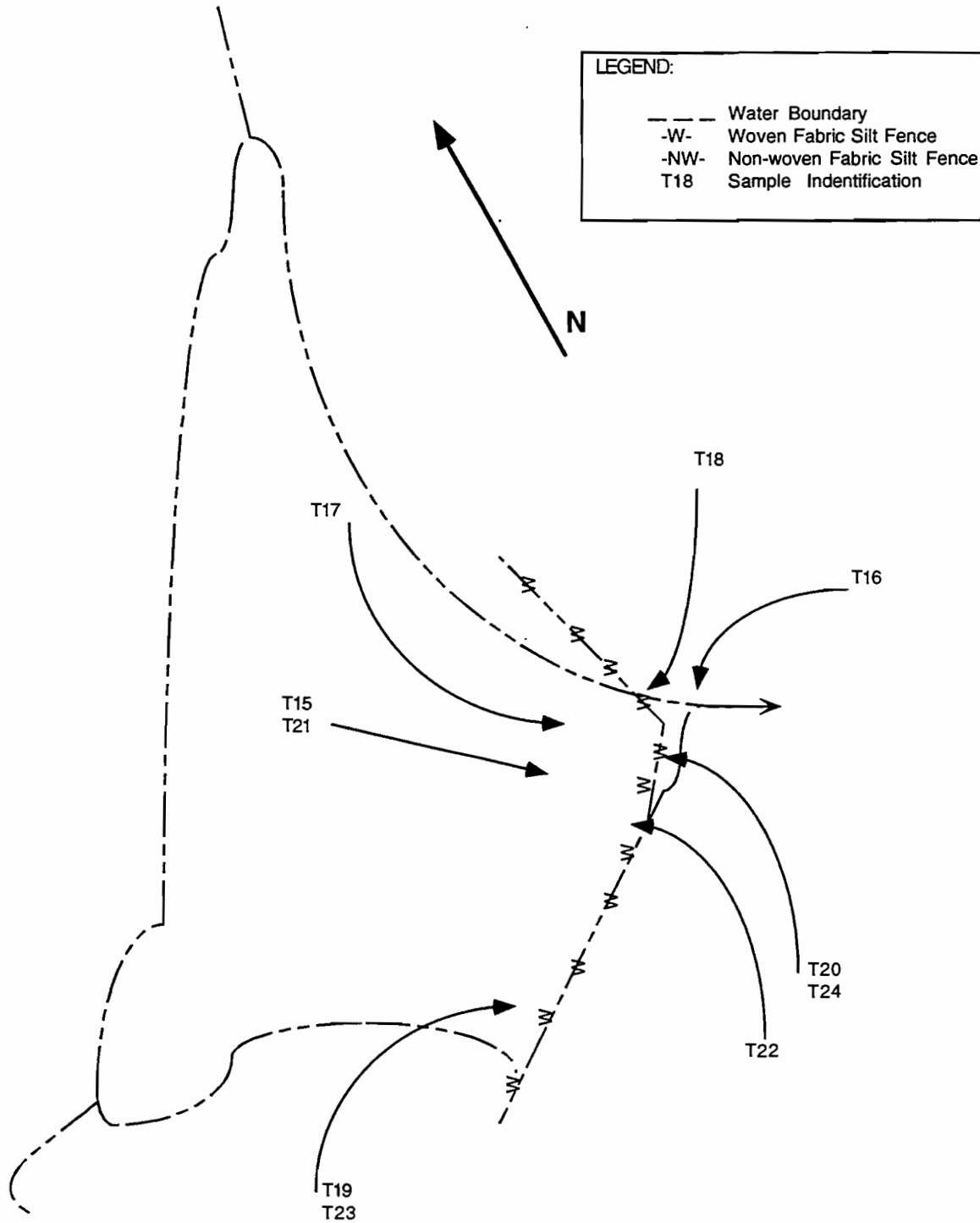

Figure A6 Sample Locations T15-T24 (Site 1)

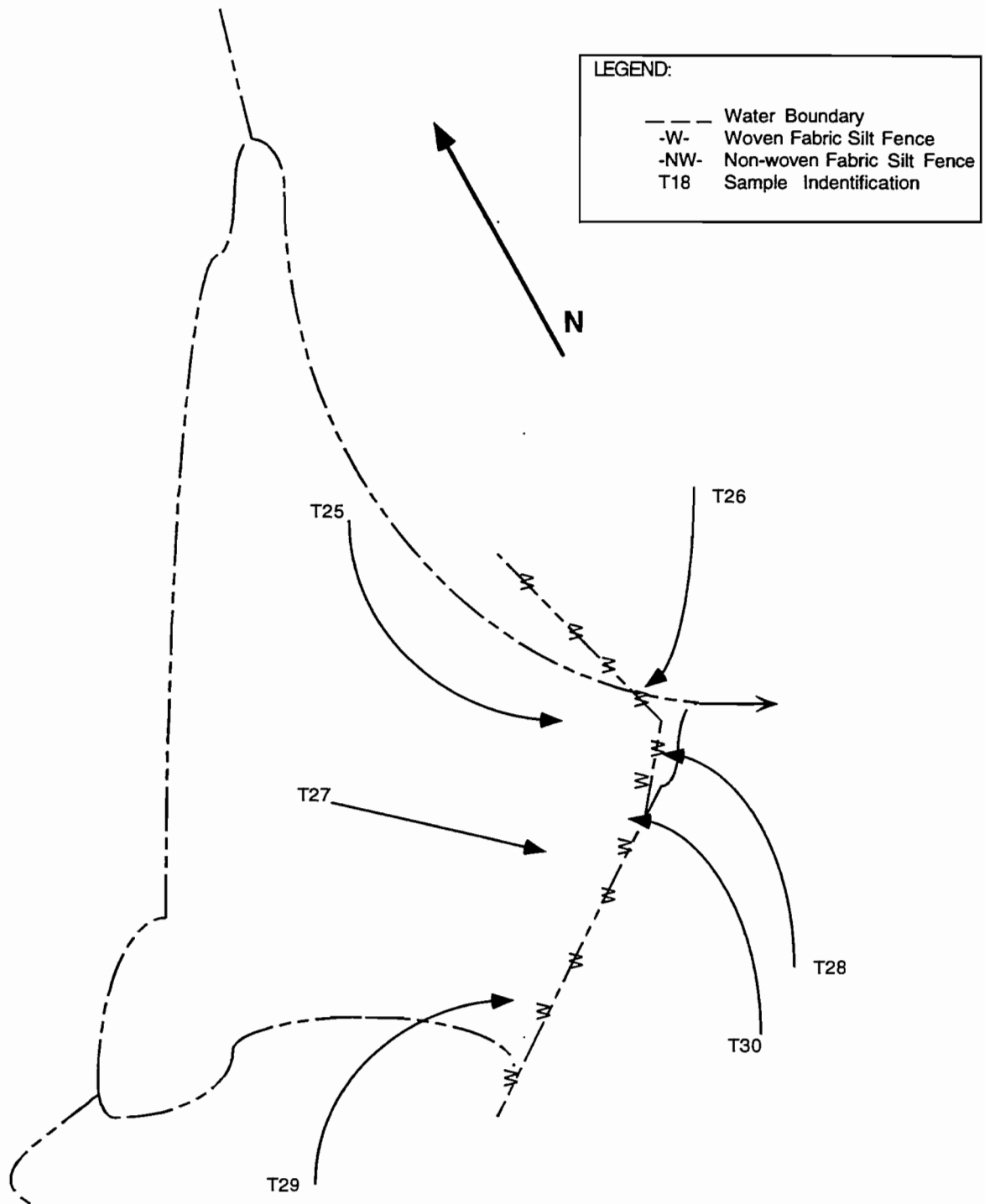

Figure A7 Sample Locations T25-T30 (Site 1)

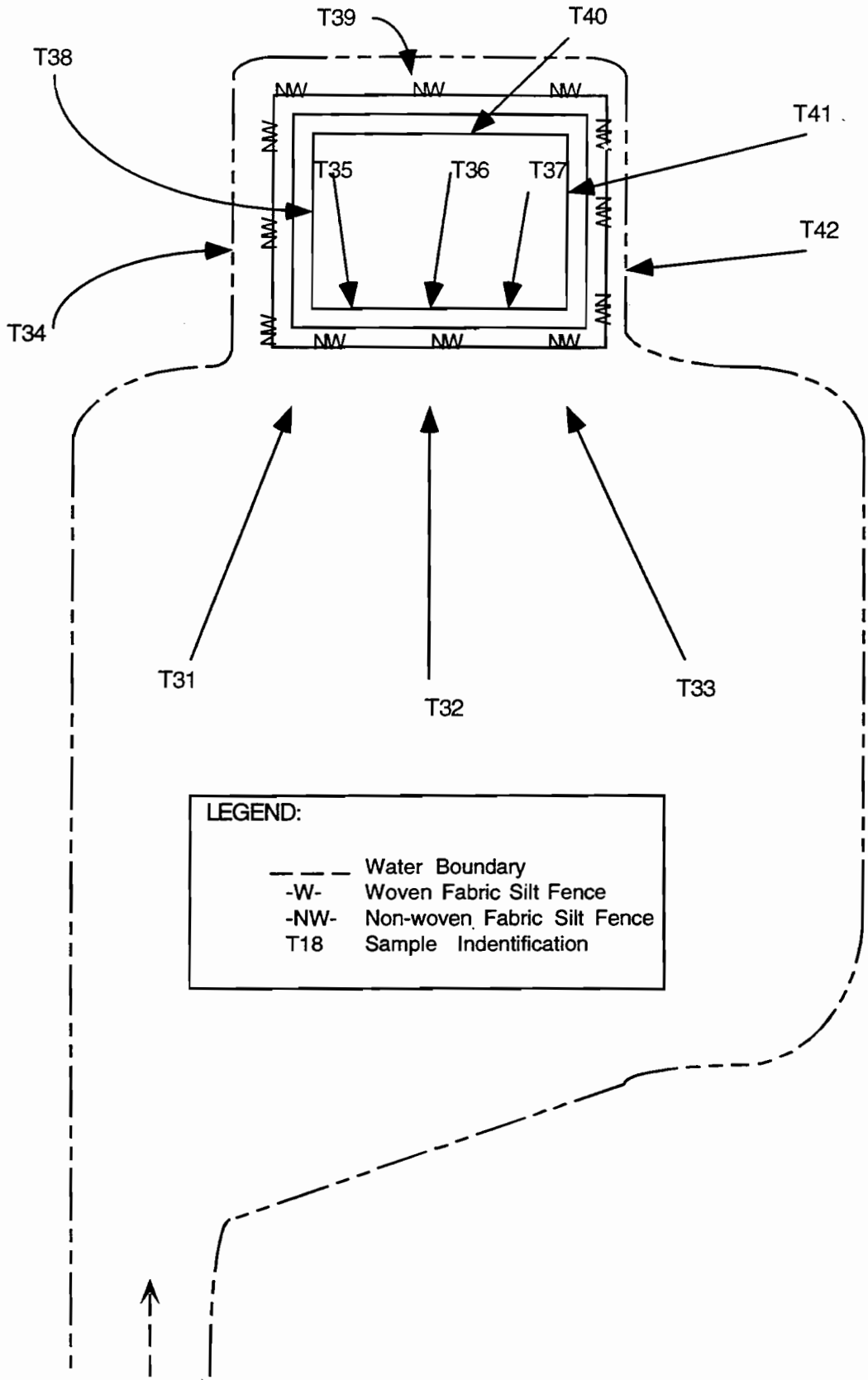

Figure A8 Sample Locations T31-T42 (Site 4, Non-woven)

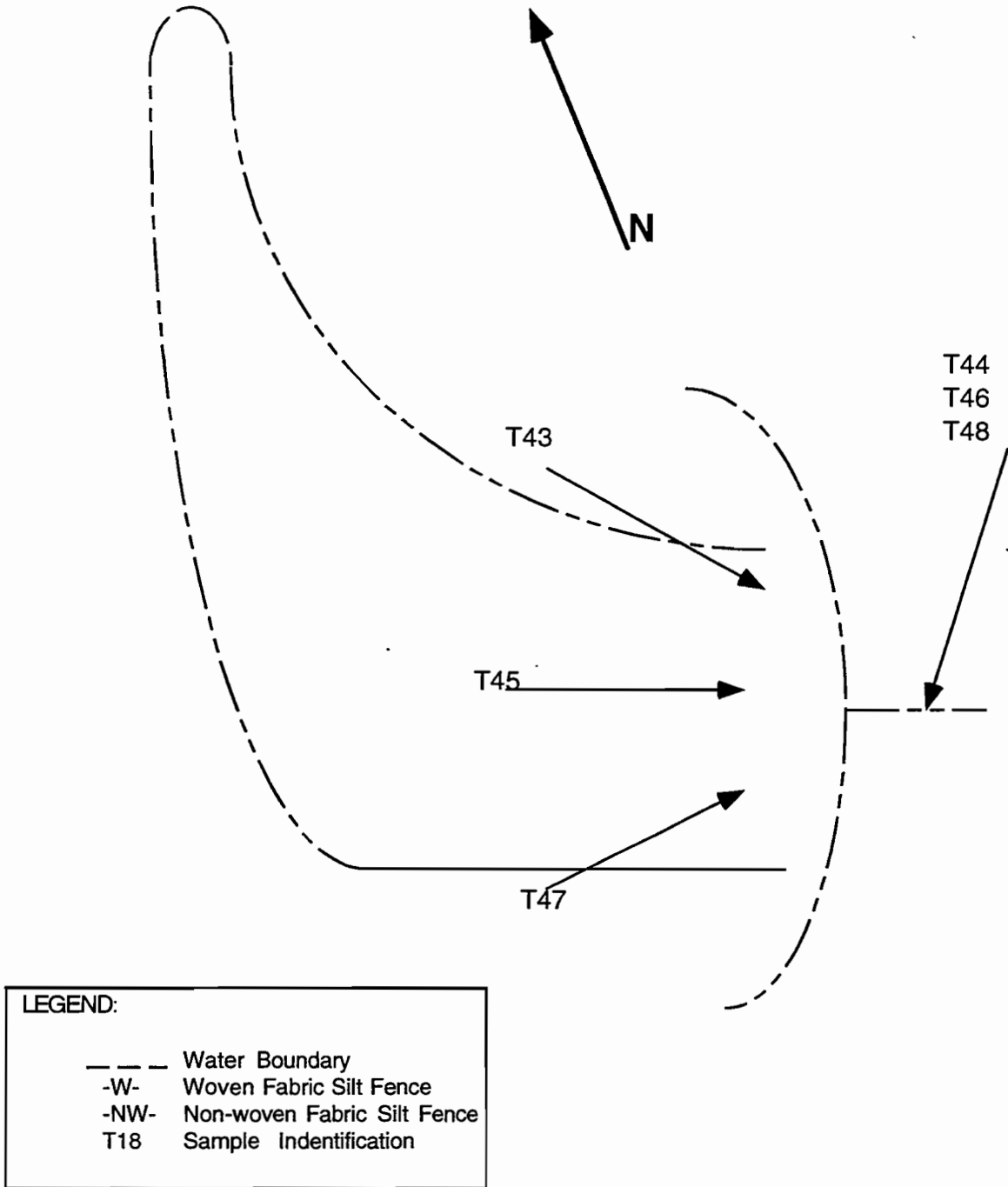

Figure A9 Sample Locations T43-T48 (Site 1)

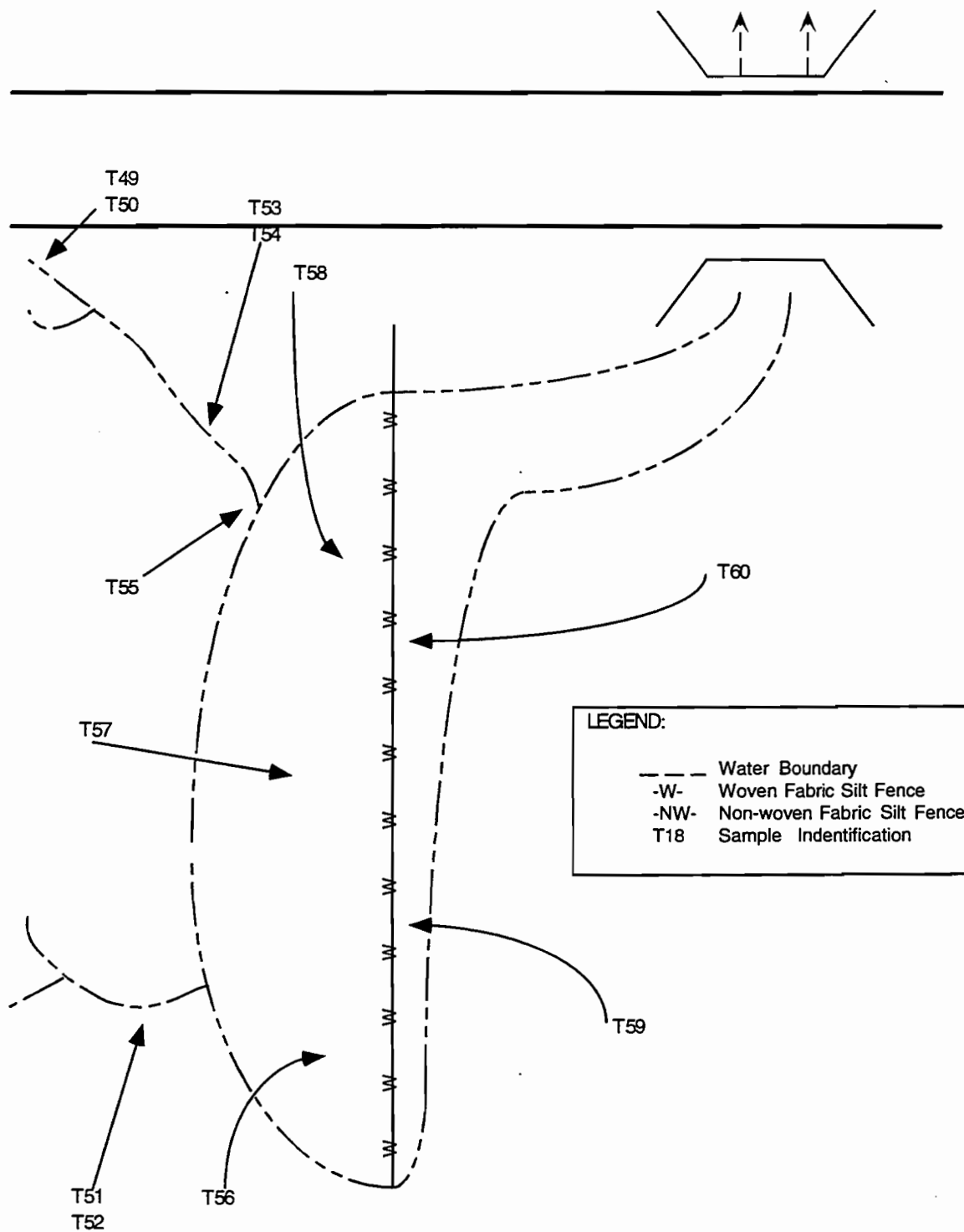

Figure A10 Sample Locations T49-T60 (Site 6)

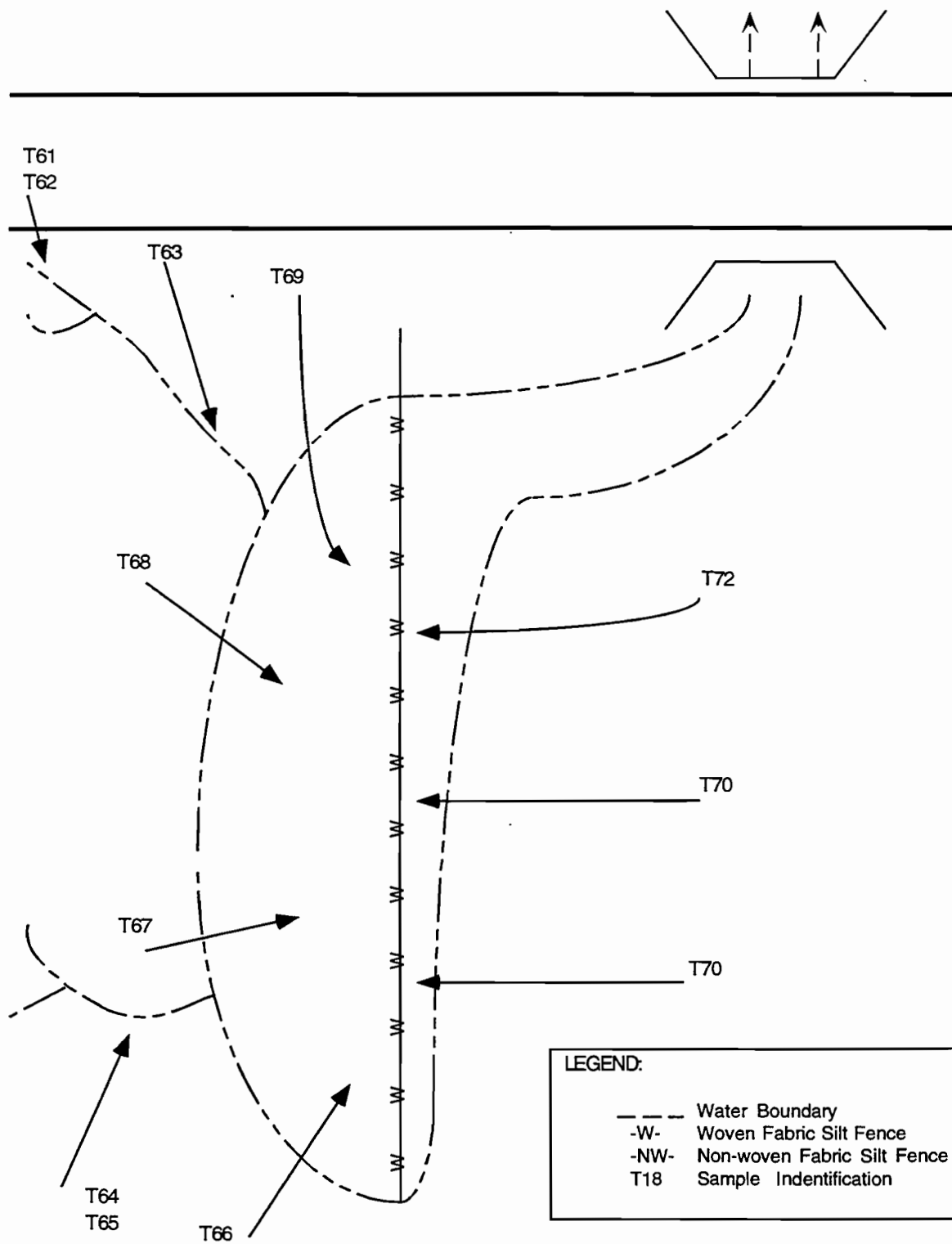

Figure A11 Sample Locations T61-T72 (Site 6)

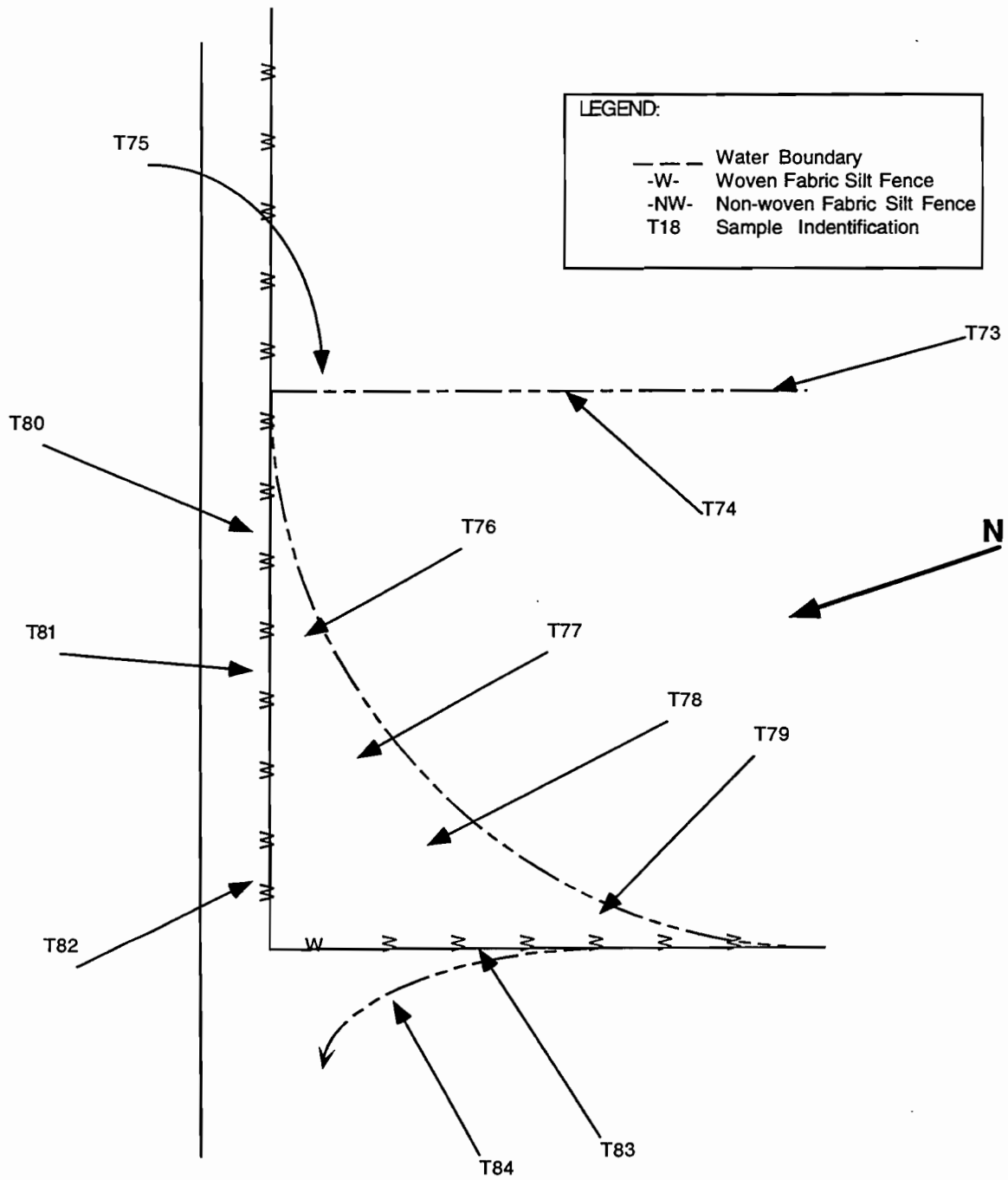

Figure A12 Sample Locations T73-T84 (Site 3)

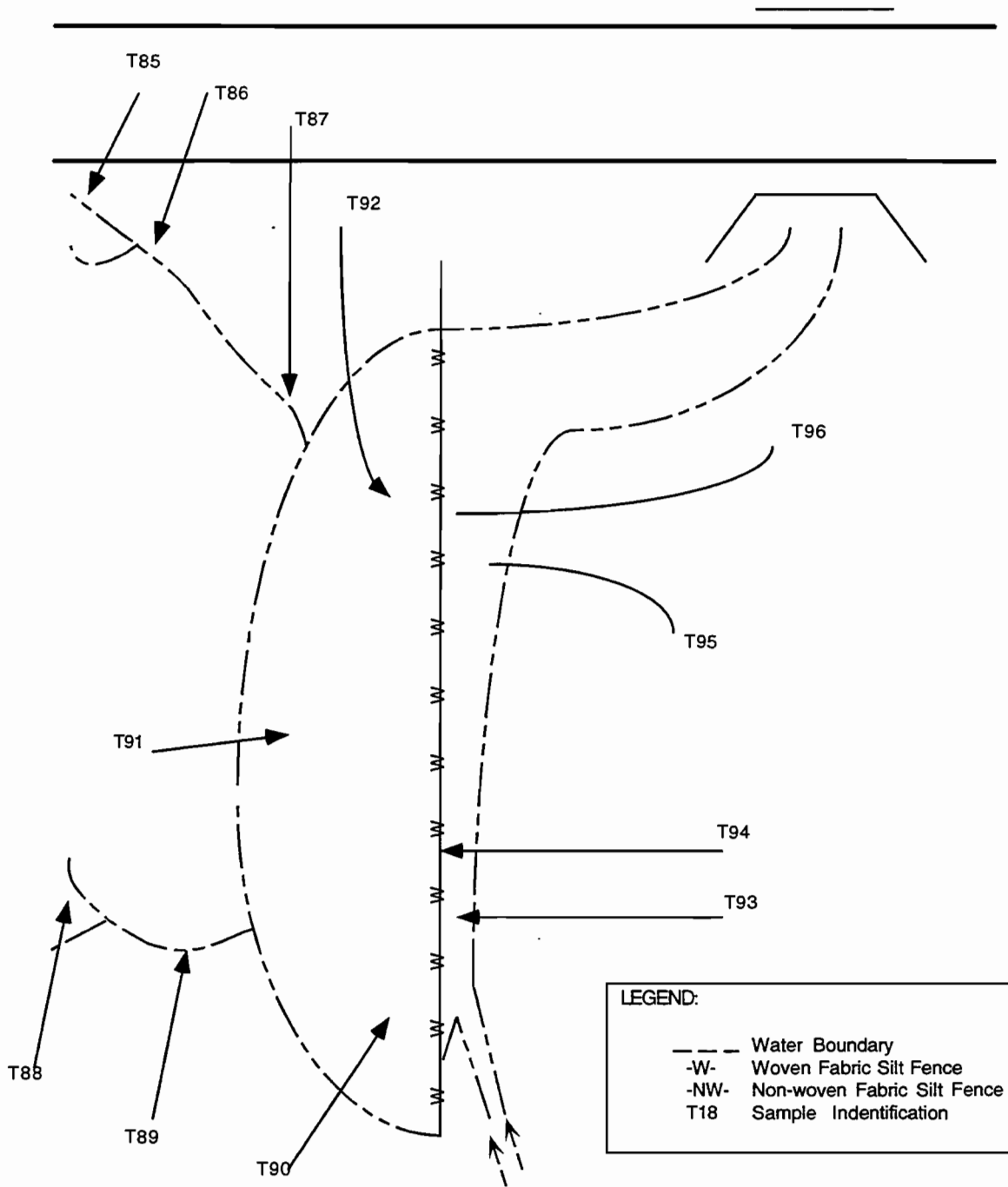

Figure A13 Sample Locations T85-T96(Site 6)

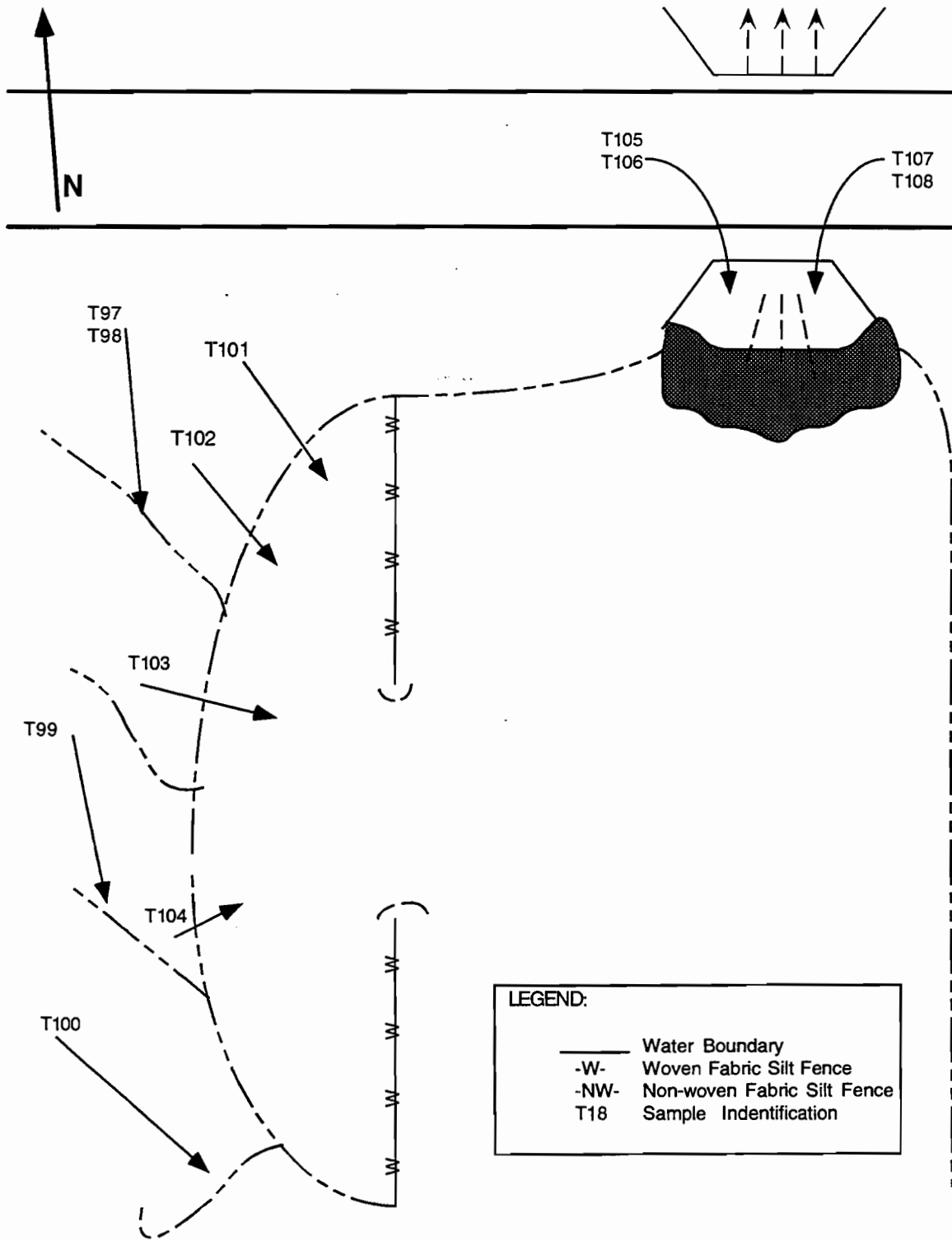

Figure A14 Sample Locations T97-T108 (Site 6)

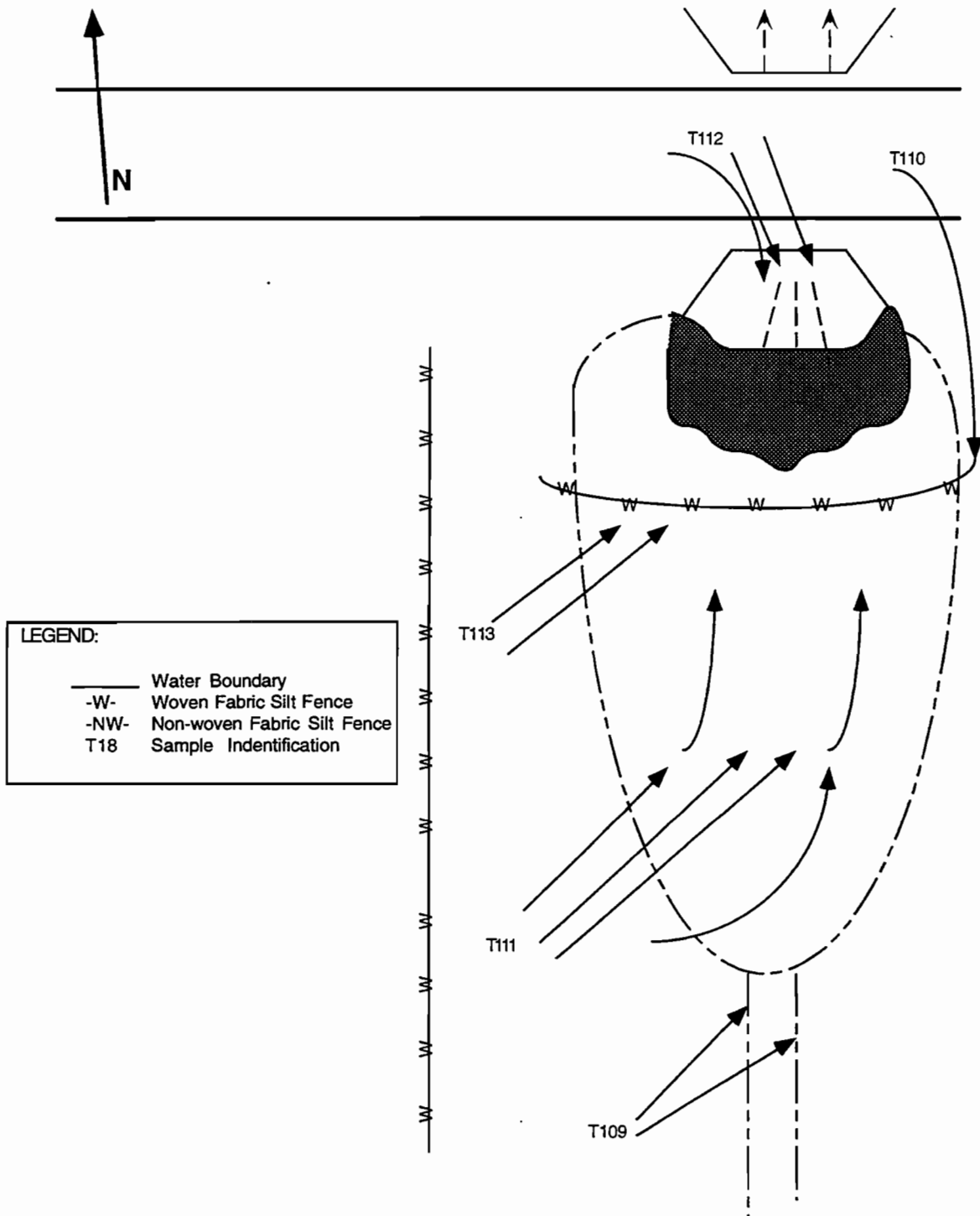

Figure A15 Sample Locations T109-T113 (Site 6)

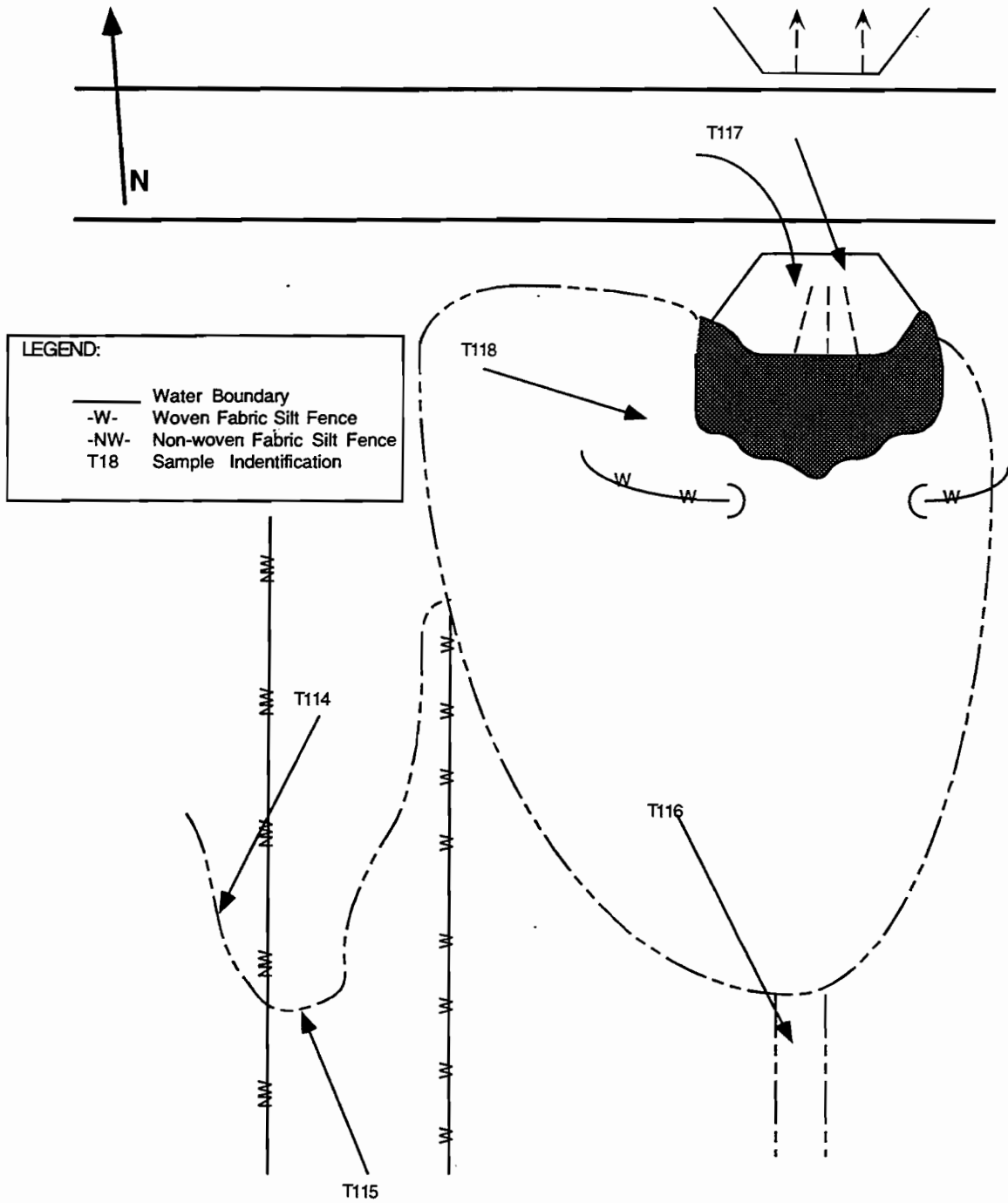

Figure A16 Sample Locations T114-T118 (Sites 6 and 7)

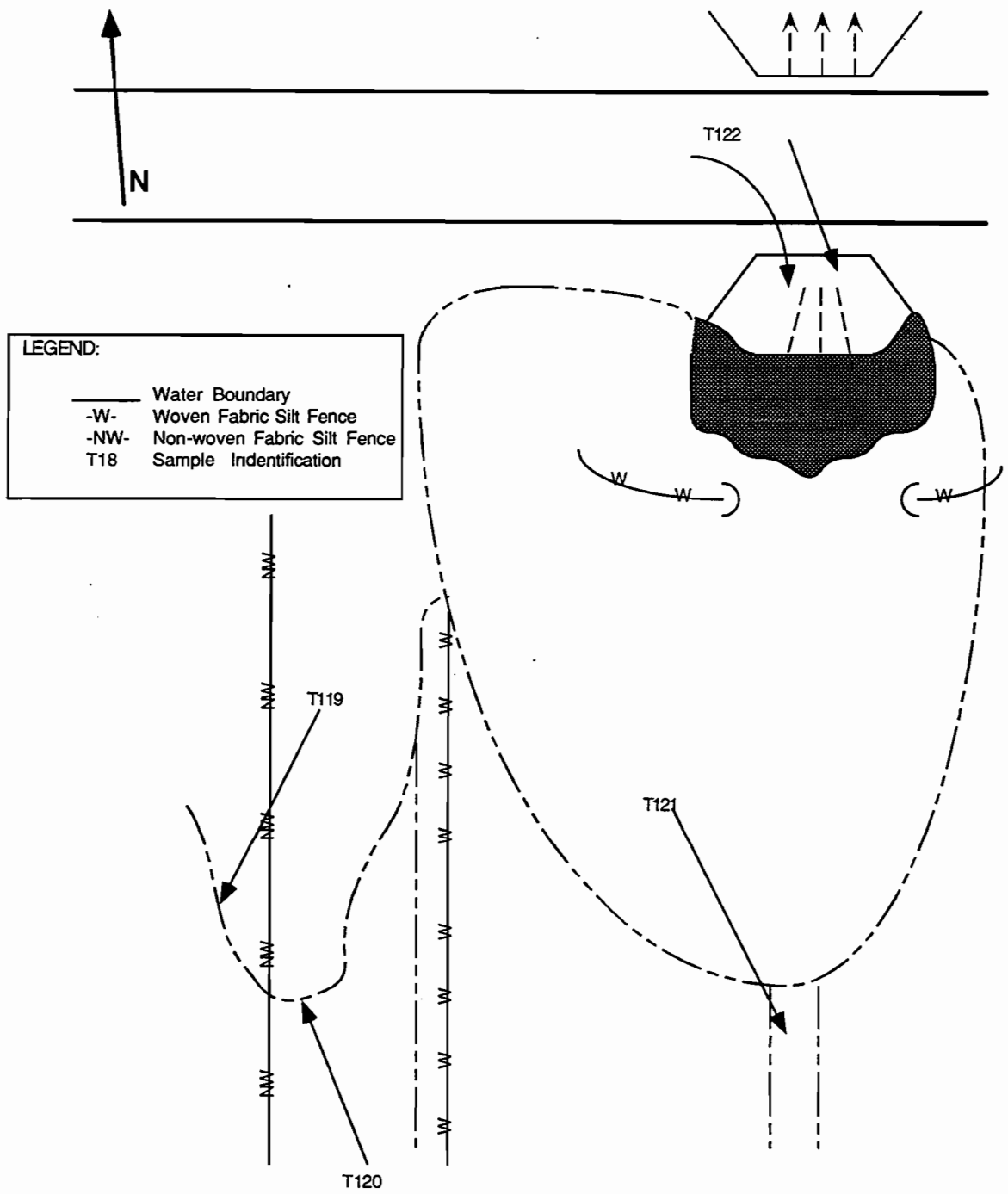

Figure A17 Sample Locations T119-122 (Sites 6 and 7)

APPENDIX B - RESULTS OF SAMPLE ANALYSES

Table B1. Individual Sample Analyses

SAMPLE #	DATE	TIME	DESCRIPTOR	SITE	TSS (mg/L)	TURBIDITY (NTU's)
T1	2/9/93	6:05PM	UPSTREAM	1	160	98
T2	2/9/93	6:05PM	DOWNSTREAM	1	90	73
T3	2/9/93	6:20PM	UPSTREAM	1	110	74
T4	2/9/93	6:20PM	DOWNSTREAM	1	160	85
T5	2/9/93	6:30PM	UPSTREAM	2	399	1300
T6	2/9/93	6:30PM	DOWNSTREAM	2	348	1250
T7	2/9/93	6:40PM	UPSTREAM	2	456	1600
T8	2/9/93	6:40PM	DOWNSTREAM	2	499	1700
T9	2/9/93	7:00PM	UPSTREAM	3	730	580
T10	2/9/93	7:00PM	DOWNSTREAM	3	720	550
T11	2/9/93	7:10PM	UPSTREAM	3	670	640
T12	2/9/93	7:10PM	DOWNSTREAM	3	665	720
T13	2/10/93	9:45AM	UPSTREAM	1	43	51
T15	2/14/93	5:30PM	UPSTREAM	1	25	21
T16	2/14/93	5:30PM	DOWNSTREAM	1	53	32
T17	2/14/93	5:45PM	UPSTREAM	1	46	19
T18	2/14/93	5:45PM	DOWNSTREAM	1	21	19
T19	2/14/93	5:55PM	UPSTREAM	1	44	25
T20	2/14/93	5:55PM	DOWNSTREAM	1	24	20
T21	2/14/93	6:15PM	UPSTREAM	1	36	29
T22	2/14/93	6:15PM	DOWNSTREAM	1	42	33
T23	2/14/93	6:30PM	UPSTREAM	1	30	28
T24	2/14/93	6:30PM	DOWNSTREAM	1	49	35
T25	2/15/93	7:40PM	UPSTREAM	1	183	82
T26	2/15/93	7:40PM	DOWNSTREAM	1	220	85
T27	2/15/93	7:55PM	UPSTREAM	1	237	180
T28	2/15/93	7:55PM	DOWNSTREAM	1	201	160
T29	2/15/93	8:05PM	UPSTREAM	1	288	170
T30	2/15/93	8:05PM	DOWNSTREAM	1	227	160
T31	2/28/93	3:15PM	UPSTREAM	4	1528	950
T32	2/28/93	3:15PM	UPSTREAM	4	583	550
T33	2/28/93	3:15PM	UPSTREAM	4	478	340
T34	2/28/93	3:15PM	UPSTREAM	4	1208	700
T35	2/28/93	3:20PM	DOWNSTREAM	4	333	230
T36	2/28/93	3:20PM	DOWNSTREAM	4	443	275
T37	2/28/93	3:20PM	DOWNSTREAM	4	488	325
T38	2/28/93	3:20PM	DOWNSTREAM	4	438	275

SAMPLE #	DATE	TIME	DESCRIPTOR	SITE	TSS (mg/L)	TURBIDITY (NTU's)
T39	2/28/93	3:30PM	UPSTREAM	4	681	450
T40	2/28/93	3:30PM	DOWNSTREAM	4	1285	488
T41	2/28/93	3:45PM	DOWNSTREAM	4	701	350
T42	2/28/93	3:45PM	UPSTREAM	4	2192	850
T43	2/28/93	5:00PM	UPSTREAM	1	125	85
T44	2/28/93	5:00PM	DOWNSTREAM	1	125	83
T45	2/28/93	5:10PM	UPSTREAM	1	128	88
T46	2/28/93	5:10PM	DOWNSTREAM	1	181	89
T47	2/28/93	5:15PM	UPSTREAM	1	139	83
T48	2/28/93	5:15PM	DOWNSTREAM	1	183	94
T49	4/7/93	9:15AM	UPSTREAM C	6	NIA	NIA
T50	4/7/93	9:15AM	UPSTREAM C	6	NIA	NIA
T51	4/7/93	9:20AM	UPSTREAM C	6	NIA	NIA
T52	4/7/93	9:20AM	UPSTREAM C	6	NIA	NIA
T53	4/7/93	9:25AM	UPSTREAM C	6	NIA	NIA
T54	4/7/93	9:25AM	UPSTREAM C	6	NIA	NIA
T55	4/7/93	9:26AM	UPSTREAM C	6	NIA	NIA
T56	4/7/93	9:26AM	UPSTREAM P	6	NIA	NIA
T57	4/7/93	9:27AM	UPSTREAM P	6	NIA	NIA
T58	4/7/93	9:27AM	UPSTREAM P	6	NIA	NIA
T59	4/7/93	9:30AM	DOWNSTREAM	6	NIA	NIA
T60	4/7/93	9:30AM	DOWNSTREAM	6	NIA	NIA
T61	4/7/93	10:50A	UPSTREAM C	6	NIA	NIA
		M				
T62	4/7/93	10:50A	UPSTREAM C	6	NIA	NIA
		M				
T63	4/7/93	10:50A	UPSTREAM C	6	NIA	NIA
		M				
T64	4/7/93	10:55A	UPSTREAM C	6	NIA	NIA
		M				
T65	4/7/93	10:55A	UPSTREAM C	6	NIA	NIA
		M				
T66	4/7/93	11:00A	UPSTREAM P	6	NIA	NIA
		M				
T67	4/7/93	11:00A	UPSTREAM P	6	NIA	NIA
		M				
T68	4/7/93	11:00A	UPSTREAM P	6	NIA	NIA
		M				
T69	4/7/93	11:00A	UPSTREAM P	6	NIA	NIA
		M				
T70	4/7/93	11:05A	DOWNSTREAM	6	NIA	NIA
		M				
T71	4/7/93	11:05A	DOWNSTREAM	6	NIA	NIA

		M				
T72	4/7/93	11:05A	DOWNSTREAM	6	NIA	NIA
		M				
T73	4/7/93	11:20A	UPSTREAM C	3	NIA	NIA
		M				
T74	4/7/93	11:20A	UPSTREAM C	3	NIA	NIA
		M				
T75	4/7/93	11:22A	UPSTREAM C	3	NIA	NIA
		M				
T76	4/7/93	11:23A	UPSTREAM P	3	NIA	NIA
		M				

SAMPLE #	DATE	TIME	DESCRIPTOR	SITE	TSS (mg/L)	TURBIDITY (NTU's)
T39	2/28/93	3:30PM	UPSTREAM	4	680.50	450
T40	2/28/93	3:30PM	DOWNSTREAM	4	1285.00	488
T41	2/28/93	3:45PM	DOWNSTREAM	4	701.00	350
T42	2/28/93	3:45PM	UPSTREAM	4	2192.00	850
T43	2/28/93	5:00PM	UPSTREAM	1	125.00	85
T44	2/28/93	5:00PM	DOWNSTREAM	1	125.00	83
T45	2/28/93	5:10PM	UPSTREAM	1	128.00	88
T46	2/28/93	5:10PM	DOWNSTREAM	1	181.00	89
T47	2/28/93	5:15PM	UPSTREAM	1	139.00	83
T48	2/28/93	5:15PM	DOWNSTREAM	1	183.00	94
T49	4/7/93	9:15AM	UPSTREAM C	6	NIA	NIA
T50	4/7/93	9:15AM	UPSTREAM C	6	NIA	NIA
T51	4/7/93	9:20AM	UPSTREAM C	6	NIA	NIA
T52	4/7/93	9:20AM	UPSTREAM C	6	NIA	NIA
T53	4/7/93	9:25AM	UPSTREAM C	6	NIA	NIA
T54	4/7/93	9:25AM	UPSTREAM C	6	NIA	NIA
T55	4/7/93	9:26AM	UPSTREAM C	6	NIA	NIA
T56	4/7/93	9:26AM	UPSTREAM P	6	NIA	NIA
T57	4/7/93	9:27AM	UPSTREAM P	6	NIA	NIA
T58	4/7/93	9:27AM	UPSTREAM P	6	NIA	NIA
T59	4/7/93	9:30AM	DOWNSTREAM	6	NIA	NIA
T60	4/7/93	9:30AM	DOWNSTREAM	6	NIA	NIA
T61	4/7/93	10:50AM	UPSTREAM C	6	NIA	NIA
T62	4/7/93	10:50AM	UPSTREAM C	6	NIA	NIA
T63	4/7/93	10:50AM	UPSTREAM C	6	NIA	NIA

T64	4/7/93	10:55AM	UPSTREAM C	6	NIA	NIA
T65	4/7/93	10:55AM	UPSTREAM C	6	NIA	NIA
T66	4/7/93	11:00AM	UPSTREAM P	6	NIA	NIA
T67	4/7/93	11:00AM	UPSTREAM P	6	NIA	NIA
T68	4/7/93	11:00AM	UPSTREAM P	6	NIA	NIA
T69	4/7/93	11:00AM	UPSTREAM P	6	NIA	NIA
T70	4/7/93	11:05AM	DOWNSTREAM	6	NIA	NIA
T71	4/7/93	11:05AM	DOWNSTREAM	6	NIA	NIA
T72	4/7/93	11:05AM	DOWNSTREAM	6	NIA	NIA
T73	4/7/93	11:20AM	UPSTREAM C	3	NIA	NIA
T74	4/7/93	11:20AM	UPSTREAM C	3	NIA	NIA
T75	4/7/93	11:22AM	UPSTREAM C	3	NIA	NIA
T76	4/7/93	11:23AM	UPSTREAM P	3	NIA	NIA

NIA - NOT
INDIVIDUALLY
ANALYZED

SAMPLE #	DATE	TIME	DESCRIPTOR	SITE	TSS (mg/L)	TURBIDITY (NTU's)
T77	4/7/93	11:24AM	UPSTREAM P	3	NIA	NIA
T78	4/7/93	11:25AM	UPSTREAM P	3	NIA	NIA
T79	4/7/93	11:26AM	UPSTREAM P	3	NIA	NIA
T80	4/7/93	11:27AM	DOWNSTREAM	3	NIA	NIA
T81	4/7/93	11:28AM	DOWNSTREAM	3	NIA	NIA
T82	4/7/93	11:29AM	DOWNSTREAM	3	NIA	NIA
T83	4/7/93	11:30AM	DOWNSTREAM	3	NIA	NIA
T84	4/7/93	11:31AM	DOWNSTREAM	3	NIA	NIA
T85	4/14/93	9:01AM	UPSTREAM C	6	NIA	NIA
T86	4/14/93	9:01AM	UPSTREAM C	6	NIA	NIA
T87	4/14/93	9:02AM	UPSTREAM C	6	NIA	NIA
T88	4/14/93	9:03AM	UPSTREAM C	6	NIA	NIA
T89	4/14/93	9:05AM	UPSTREAM C	6	NIA	NIA
T90	4/14/93	9:05AM	UPSTREAM P	6	NIA	NIA
T91	4/14/93	9:06AM	UPSTREAM P	6	NIA	NIA
T92	4/14/93	9:06AM	UPSTREAM P	6	NIA	NIA
T93	4/14/93	9:09AM	DOWNSTREAM	6	NIA	NIA
T94	4/14/93	9:09AM	DOWNSTREAM	6	NIA	NIA
T95	4/14/93	9:10AM	DOWNSTREAM	6	NIA	NIA
T96	4/14/93	9:13AM	DOWNSTREAM	6	NIA	NIA
T97	4/29/93	6:10AM	UPSTREAM C	6	NIA	NIA
T98	4/29/93	6:10AM	UPSTREAM C	6	NIA	NIA
T99	4/29/93	6:12AM	UPSTREAM C	6	NIA	NIA
T100	4/29/93	6:13AM	UPSTREAM C	6	NIA	NIA

T101	4/29/93	6:14AM	UPSTREAM P	6	NIA	NIA
T102	4/29/93	6:14AM	UPSTREAM P	6	NIA	NIA
T103	4/29/93	6:15AM	UPSTREAM P	6	NIA	NIA
T104	4/29/93	6:16AM	UPSTREAM P	6	NIA	NIA
T105	4/29/93	6:17AM	DOWNSTREAM	6	NIA	NIA
T106	4/29/93	6:17AM	DOWNSTREAM	6	NIA	NIA
T107	4/29/93	6:20AM	DOWNSTREAM	6	NIA	NIA
T108	4/29/93	6:20AM	DOWNSTREAM	6	NIA	NIA

Table B2. Results of Particle Size Analyses

SAMPLE	DESCRIPTOR	SITE	TSS B	TSS A	% > SILT	% SILT & CLAY
#			(mg/L)	(mg/L)		
TC1	UPSTREAM	1	45.00	34.00	24	76
TC2	DOWNSTREAM	1	53.00	40.00	25	75
TC3	UPSTREAM	1	243.00	228.00	6	94
TC4	DOWNSTREAM	1	244.00	242.00	1	99
TC5	UPSTREAM	4	1223.00	1164.67	5	95
TC6	DOWNSTREAM	4	568.00	561.33	1	99
TC7	UPSTREAM	1	112.00	89.00	21	79
TC8	DOWNSTREAM	1	180.50	157.00	13	87
TC9	UPSTREAM C	6	2010.00	1745.00	13	87
TC10	UPSTREAM P	6	1510.00	1430.00	5	95
TC11	DOWNSTREAM	6	1510.00	1480.00	2	98
TC12	UPSTREAM C	6	625.00	620.00	1	99
TC13	UPSTREAM P	6	755.00	675.00	11	89
TC14	DOWNSTREAM	6	895.00	890.00	1	99
TC15	UPSTREAM C	3	850.00	850.00	0	100
TC16	UPSTREAM P	3	930.00	895.00	4	96
TC18	DOWNSTREAM	3	935.00	835.00	11	89
TC19	UPSTREAM C	6	1522.50	1235.00	19	81
TC20	UPSTREAM P	6	1360.00	1360.00	0	100
TC21	DOWNSTREAM	6	1950.00	1925.00	1	99
TC22	UPSTREAM C	6	3045.00	2950.00	3	97
TC23	UPSTREAM P	6	3435.00	3075.00	10	90
TC24	DOWNSTREAM	6	3445.00	3420.00	1	99
T109	UPSTREAM C	6	350.00	340.00	3	97
T110	UPSTREAM C	6	1060.00	860.00	19	81
T111	UPSTREAM P	6	395.00	385.00	3	97
T112	DOWNSTREAM	6	700.00	635.00	9	91
T113	DOWNSTREAM	6	355.00	350.00	1	99
T114	UPSTREAM C	7	11350.00	10990.00	3	97
T115	DOWNSTREAM	7	13100.00	12640.00	4	96
T116	UPSTREAM C	6	1320.00	1070.00	19	81
T117	DOWNSTREAM	6	2520.00	2470.00	2	98
T118	UPSTREAM P	6	2355.00	2230.00	5	95
T119	UPSTREAM C	7	3530.00	3440.00	3	97
T120	DOWNSTREAM	7	3380.00	3290.00	3	97
T121	UPSTREAM C	6	2440.00	1650.00	32	68
T122	DOWNSTREAM	6	2430.00	2360.00	3	97
MEAN						92
MEDIAN						96
STD DEV						8

Table B3. Silt Fence TSS Reductions

SAMPLE#	LOCATION	SITE	TSS (mg/L)	% TSS REDUCTION
TA1	UPSTREAM	1	135.00	7
TA2	DOWNSTREAM	1	125.00	
TA3	UPSTREAM	2	427.50	1
TA4	DOWNSTREAM	2	423.50	
TA5	UPSTREAM	3	700.00	1
TA6	DOWNSTREAM	3	692.50	
TC1	UPSTREAM	1	45.00	-18
TC2	DOWNSTREAM	1	53.00	
TC3	UPSTREAM	1	243.00	0
TC4	DOWNSTREAM	1	244.00	
TC5	UPSTREAM	4	1223.00	54
TC6	DOWNSTREAM	4	568.00	
TC7	UPSTREAM	1	112.00	-61
TC8	DOWNSTREAM	1	180.50	
TA7	UPSTREAM	1	131.00	5
T44	DOWNSTREAM	1	125.00	
TC10	UPSTREAM P	6	1510.00	0
TC11	DOWNSTREAM	6	1510.00	
TC13	UPSTREAM P	6	755.00	-19
TC14	DOWNSTREAM	6	895.00	
TC16	UPSTREAM P	3	930.00	-1
TC18	DOWNSTREAM	3	935.00	
TC20	UPSTREAM P	6	1360.00	-43
TC21	DOWNSTREAM	6	1950.00	
T111	UPSTREAM P	6	395.00	10
T113	DOWNSTREAM	6	355.00	
T114	UPSTREAM C	7	11350.00	-15
T115	DOWNSTREAM	7	13100.00	
T119	UPSTREAM C	7	3530.00	4
T120	DOWNSTREAM	7	3380.00	
MEDIAN				0
MEAN				-5
STD. DEV.				26

Table B4. Silt Fence Turbidity Reductions

SAMPLE#	LOCATION	SITE	TURBIDITY (NTU's)	% TURBIDITY REDUCTION
TA1	UPSTREAM	1	86	8
TA2	DOWNSTREAM	1	79	
TA3	UPSTREAM	2	1450	-2
TA4	DOWNSTREAM	2	1475	
TA5	UPSTREAM	3	610	-4
TA6	DOWNSTREAM	3	635	
TC1	UPSTREAM	1	24.4	-14
TC2	DOWNSTREAM	1	27.8	
TC3	UPSTREAM	1	144	6
TC4	DOWNSTREAM	1	135	
TC5	UPSTREAM	4	640	49
TC6	DOWNSTREAM	4	323.8	
TC7	UPSTREAM	1	85.3	-4
TC8	DOWNSTREAM	1	88.7	
TA7	UPSTREAM	1	85.3	3
T44	DOWNSTREAM	1	83	
TC10	UPSTREAM P	6	720	-14
TC11	DOWNSTREAM	6	820	
TC13	UPSTREAM P	6	368	-20
TC14	DOWNSTREAM	6	440	
TC16	UPSTREAM P	3	920	4
TC18	DOWNSTREAM	3	880	
TC20	UPSTREAM P	6	680	-32
TC21	DOWNSTREAM	6	900	
T111	UPSTREAM P	6	196	2
T113	DOWNSTREAM	6	192	
T114	UPSTREAM C	7	2160	4
T115	DOWNSTREAM	7	2080	
T119	UPSTREAM C	7	1250	2
T120	DOWNSTREAM	7	1220	
MEDIAN				2
MEAN				-1
STD DEV				18

APPENDIX C - LABORATORY PROCEDURES

Total Suspended Solids

The analysis for TSS was conducted according to the procedure outlined in *Standard Methods for the Examination Of Water and Wastewater* (1992) section 2540 D, Total Suspended Solids Dried at 103-105°C. Initially, 20 to 30 mL of distilled water are passed through the filter. The filter is dried in an oven for 1 hour, allowed to cool in a desiccator for 15 to 20 minutes, and weighed. A Whatman grade 934AH filter and a filtration apparatus which is the equivalent of a Gelman No. 4201 was used for filtering the samples.

Subsequently, 10 to 100 mL of the water sample was filtered. The solids retained on the filter and the filter are dried in an oven at 103°C for 1 hour and cooled in a desiccator for 15 to 20 minutes. The residue and the filter are weighed, and the total suspended solids are calculated as:

$$\text{mg total suspended solids/L} = \frac{(A - B) \times 100}{\text{sample volume (mL)}}$$

where: A = weight of filter + dried residue, mg, and

B = weight of filter, mg.

Duplicate samples were analyzed for every tenth TSS analysis as a quality control measure, and the average of the results was reported.

Turbidity

Turbidity is defined as an “expression of the optical property that causes light to be scattered and absorbed rather than transmitted in straight lines through the sample” (*Standard Methods for the Examination of Water and Wastewater*, 1992), and commonly is used as a standard for assessing the clarity of water designated for human consumption and manufacturing usage. The extent to which suspended silts and clays, organic and inorganic matter, and microscopic organisms are present in a sample defines the clarity and in turn the turbidity of a sample (*Standard Methods for the Examination of Water and Wastewater*, 1992).

A Hach Model 2100A Turbidimeter was used to estimate turbidity. The measured turbidity of a distilled water sample was used as a blank for sample analysis. Turbidity readings were obtained from the appropriate primary and secondary scales. Values are reported in nephelometric turbidity units (NTU's). Duplicate analyses were conducted for every tenth sample. The average value was reported for duplicate analyses.

Dilution was used for highly turbid samples to bring the sample into the instrument range. The measured turbidity was multiplied by the dilution factor to obtain corrected turbidity values for the original sample.

Suspended Particle Size Classification

Particle size influences the primary functional mechanisms for control. Therefore, some insight regarding particle size of the suspended solids is required to successfully evaluate the performance of the system.

A method for approximating the percentage of silt and clay particles and the percentage of particles larger than silts was developed. Each sample was evaluated for TSS as collected or as composited according to the procedure described previously. Subsequently, the sample was reanalyzed for TSS after passing the sample through a U.S. Standard number 230 sieve with nominal openings of 63 mm. The formula for percentage of silts and clays:

$$\% = 100 - \left(\frac{\text{TSS B} - \text{TSS A}}{\text{TSS B}} \times 100 \right)$$

where: TSS B = TSS before #230 sieving (mg/L) and

TSS A = TSS after #230 sieving (mg/L).

In reality, this estimate is conservative. AASHTO classifies silts and clays as those particles smaller than 75 mm. Wet sieving results in some particle adherence to the screen.

APPENDIX D - CATALOG OF FLUME TESTS

Test number:		3		Influent Samples :				
Date =	4/20/94	Sample	Time, min	TSS,	ΔT	TSS* ΔT		
Starting Time =	11:00	1	2		240	0		
Filling Time =	1120 sec	2	6		240	0		
Silt Fence:		3	10		240	0		
Belton woven 751-36		4	14		240	0		
AOS =	#30	5	18		160	0		
Ψ =	0.4 sec ⁻¹							
Bulk flow:								
Head over weir =	0.132 m							
Slurry tank:								
Start =	1.850 m			Σ =	720	0		
End =	1.482 m			MIC =	1810	mg/L		
Total Inflow:								
Q total =	2.75 Lps	Flume & Pond:						
V in =	3.08 m ³	Area of pond =		6.12	m ²			
Soil Added:		Width of Fence=		0.711	m			
Wt of wet solids =	19.3 kg	Undrained Vol of Tank =		0.127	m ³			
Hydraulic Data & Effluent Samples:								
Time, min	Level, m	Sample	TSS, mg/L	ΔV , m ³	TSS* ΔV , g	T_{avg} , min	T_{avg} * ΔV	
0	0.000							
4	0.064	1	1080	0.140	152	2	0	
8	0.152	2	1110	0.121	137	6	1	
12	0.232	3	1140	0.170	193	10	2	
16	0.299	4	1140	0.249	284	14	3	
19	0.352			0.170	209	18	3	
22	0.338	5	1230	0.086	105	21	2	
34	0.296	6	850	0.257	218	28	7	
51	0.258	7	360	0.233	84	43	10	
75	0.220	8	255	0.233	59	63	15	
105	0.180	9	130	0.245	32	90	22	
135	0.155	10	145	0.153	22	120	18	
165	0.135	11	100	0.122	12	150	18	
210	0.103	12	65	0.196	13	188	37	
300	0.080	13	75	0.141	11	255	36	
360	0.074			0.037	1	330	12	
420	0.070			0.024	1	390	10	
480	0.067	14	35	0.018	1	450	8	
600	0.062			0.031	1	540	17	
795	0.057	15	25	0.031	1	698	21	
840	0.054	16	5	0.018	0	818	15	
960	0.050			0.024	0	900	22	
1200	0.045			0.031	0	1080	33	
1620	0.038			0.043	0	1410	60	
2100	0.033			0.031	0	1860	57	
2880	0.028			0.031	0	2490	76	
5520	0.000			0.172		4200	722	
				Σ =	2.83	1537		1228
MEC =	543	mg/L	ζ =	72	%	T_d =	409	min

Test number:		5		Influent Samples :				
Date =	5/9/94	Sample	Time, min	TSS,	ΔT	TSS* ΔT		
Starting Time =	14:30	1	2		240	0		
Filling Time =	1260 sec	2	6		240	0		
Silt Fence:		3	10		240	0		
Belton woven 751-36		4	14		240	0		
AOS =	#30	5	18		300	0		
$\Psi =$	0.4 sec ⁻¹							
Bulk flow:								
Head over weir =	0.132 m							
Slurry tank:								
Start =	1.850 m				$\Sigma =$	720	0	
End =	1.564 m				MIC =	910	mg/L	
Total Inflow:								
Q total =	2.72 Lps	Flume & Pond:						
V in =	3.43 m ³	Area of pond =			6.12	m ²		
Soil Added:		Width of Fence =			0.711	m		
Wt of wet solids =	19.3 kg	Undrained Vol of Tank =			0.127	m ³		
Hydraulic Data & Effluent Samples:								
Time, min	Level, m	Sample	TSS, mg/L	ΔV , m ³	TSS* ΔV , g	T_{avg} , min	T_{avg} * ΔV	Observed
0	0.000							
5	0.100	1		0.078	32	3	0	
10	0.200	2	410	0.202	83	8	2	
15	0.284	3	475	0.301	143	13	4	
20	0.345	4	555	0.443	246	18	8	
21	0.350			0.052	31	20	1	
25	0.324	5	605	0.158	95	23	4	
30	0.299	6	590	0.155	91	28	4	
60	0.211	7	360	0.541	195	45	24	
90	0.160	8	245	0.309	76	75	23	
120	0.125	9	130	0.216	28	105	23	
150	0.100	10	140	0.153	21	135	21	
180	0.088	11	40	0.074	3	165	12	
240	0.077	12	125	0.063	8	210	13	
300	0.068	13	65	0.060	4	270	16	
360	0.061	14	25	0.040	1	330	13	
420	0.056	15	15	0.032	0	390	12	
480	0.051	16	15	0.028	0	450	12	
600	0.046	17	5	0.033	0	540	18	
720	0.042	18	5	0.026	0	660	17	
840	0.040	19	5	0.012	0	780	9	
960	0.036	20	0	0.025	0	900	23	
1080	0.034	21	5	0.012	0	1020	12	
1200	0.029	22	5	0.028	0	1140	32	
1320	0.021	23	5	0.051	0	1260	64	
1790	0.000	24	95	0.128	12	1555	199	
			$\Sigma =$	3.22	1072		566	
MEC =	333 mg/L	$\zeta =$	66 %	$T_d =$	176 min			

Test number:	10		Influent Samples :					
Date =	6/30/94		Sample	Time, min	TSS,	ΔT	TSS* ΔT	
Starting Time =	11:40		1	2	4868	240	1168320	
Filling Time =	1560	sec	2	6	4536	240	1088640	
Silt Fence:			3	10	4880	240	1171200	
Exxon woven			4	14	5040	240	1209600	
AOS =	#30		5	18	4844	240	1162560	
$\Psi =$	0.1	sec ⁻¹	6	22	6060	360	2181600	
Bulk flow:								
Head over weir =	0.106	m						
Slurry tank:								
Start =	1.850	m			$\Sigma =$	1560	7981920	
End =	1.362	m			MIC =	5117	mg/L	
Total Inflow:								
Q total =	1.64	Lps			Flume & Pond:			
V in =	2.56	m ³			Area of pond =	6.12	m ²	
Soil Added:					Width of Fence=	0.711	m	
Wt of wet solids =	41.3	kg			Undrained Vol of Tank =	0.127	m ³	
Hydraulic Data & Effluent Samples:								
Time, min	Level, m	Sample	TSS, mg/L	ΔV , m ³	TSS* ΔV	Q, L/s-m ²	T _{avg} , min	T _{avg} * ΔV
0	0.000							
5	0.049	1	3072	0.066	202		3	0
10	0.130	2	2288	-0.003	-7		8	0
15	0.198	3	2500	0.076	191		13	1
20	0.266	4	2780	0.076	213		18	1
26	0.352			0.065	196		23	1
30	0.343	6	3016	0.055	166		28	2
45	0.305			0.233	316		38	9
60	0.280	7	1360	0.153	208	0.82	53	8
75	0.260			0.122	51		68	8
90	0.243	8	416	0.104	43		83	9
120	0.216	9	292	0.165	48		105	17
150	0.194	10		0.135	16		135	18
180	0.176	11	122	0.110	13		165	18
210	0.159			0.104	9		195	20
240	0.147	12	84	0.073	6	0.38	225	17
300	0.127	13	64	0.122	8		270	33
360	0.113	14	60	0.086	5		330	28
500	0.092			0.129	5		430	55
600	0.083			0.055	2		550	30
720	0.074			0.055	2		660	36
1230	0.052			0.135	5		975	131
1440	0.043			0.055	2		1335	74
1560	0.039			0.024	1		1500	37
1800	0.033			0.037	1		1680	62
2680	0.016	15	40	0.104	4		2240	233
3450	0.000			0.096			3065	294
			$\Sigma =$	2.34	1709			1144
MEC =	731	mg/L	$\zeta =$	87	%	T_d =	470	min

Test number:		11		Influent Samples :				
Date =	7/5/94	Sample	Time, min	TSS,	ΔT	TSS* ΔT		
Starting Time =	11:10	1	2	5220	240	1252800		
Filling Time =	1590 sec	2	6	4536	240	1088640		
Silt Fence:		3	10	4780	240	1147200		
Exxon woven		4	14	4536	240	1088640		
AOS =	#30	5	18	4820	240	1156800		
Ψ =	0.1 sec ⁻¹	6	22	5060	240	1214400		
Bulk flow:		7	26	3716	150	557400		
Head over weir =	0.106 m							
Slurry tank:								
Start =	1.850 m				Σ =	1590	7505880	
End =	1.362 m				MIC =	4721	mg/L	
Total Inflow:								
Q total =	1.64 Lps				Flume & Pond:			
V in =	2.61 m ³				Area of pond =	6.12	m ²	
Soil Added:					Width of Fence =	0.711	m	
Wt of wet solids =	40.8 kg				Undrained Vol of Tank =	0.127	m ³	
Hydraulic Data & Effluent Samples:								
Time, min	Level, m	Sample	TSS, mg/L	ΔV , m ³	TSS* ΔV , g	T_{avg} , min	T_{avg} * ΔV	
0	0.000							
5	0.050	1	2488	0.059	147	3	0	
10	0.135	2	2044	-0.028	-57	8	0	
15	0.210	3	2240	0.033	74	13	0	
20	0.280	4	2876	0.064	183	18	1	
25	0.350	5	2940	0.064	188	23	1	
27	0.355			0.117	369	26	3	
30	0.340	6	3156	0.092	290	28	3	
60	0.270	7	1516	0.428	649	45	19	
90	0.230	8	304	0.245	74	75	18	
120	0.190	9	144	0.245	35	105	26	
150	0.170	10	112	0.122	14	135	17	
180	0.150	11	74	0.122	9	165	20	
240	0.120	12	48	0.184	9	210	39	
300	0.110	13	40	0.061	2	270	17	
360	0.100	14	24	0.061	1	330	20	
420	0.097			0.020	0	390	8	
480	0.094			0.020	0	450	9	
600	0.087			0.040	0	540	21	
720	0.082			0.031	0	660	20	
840	0.080			0.012	0	780	10	
960	0.078			0.012	0	900	11	
1200	0.074			0.024	0	1080	26	
1620	0.065			0.055	0	1410	78	
2100	0.0538			0.069	0	1860	128	
2880	0.040	15	4	0.084	0	2490	210	
4870	0.000			0.242		3875	939	
				Σ =	2.24	1991		1644
MEC =	890 mg/L	ζ =	84 %	T_d =	663	min		

Test number:		12		Influent Samples :			
Date =	7/8/94	Sample	Time, min	TSS,	ΔT	TSS* ΔT	
Starting Time =	?	1	2	5868	240	1408320	
Filling Time =	1545 sec	2	6	4208	240	1009920	
Silt Fence:		3	10	3580	240	859200	
Exxon woven		4	14	3384	240	812160	
AOS =	#30	5	18	3228	240	774720	
$\Psi =$	0.1 sec ⁻¹	6	22	1792	345	618240	
Bulk flow:							
Head over weir =	0.106 m						
Slurry tank:							
Start =	1.850 m			$\Sigma =$	1545	5482560	
End =	1.365 m			MIC =	3549	mg/L	
Total Inflow:							
Q total =	1.64 Lps			Flume & Pond:			
V in =	2.54 m ³			Area of pond =	6.12	m ²	
Soil Added:				Width of Fence =	0.711	m	
Wt of wet solids =	27.2 kg			Undrained Vol of Tank =	0.127	m ³	
Hydraulic Data & Effluent Samples:							
Time, min	Level, m	Sample	TSS, mg/L	ΔV , m ³	TSS* ΔV , g	T _{avg} , min	T _{avg} * ΔV
0	0.000						
5	0.060			-0.001	-3	3	0
10	0.150			-0.058	-132	8	0
15	0.220			0.064	146	13	1
20	0.290	1	2276	0.064	146	18	1
25	0.350			0.126	267	23	3
26	0.360			0.013	27	25	0
30	0.345			0.092	195	28	3
40	0.320	2	2124	0.153	325	35	5
60	0.290	3	1220	0.184	224	50	9
90	0.260	4	620	0.184	114	75	14
120	0.230	5	248	0.184	46	105	19
180	0.192	6	136	0.233	32	150	35
240	0.167	7	96	0.153	15	210	32
360	0.140	8	56	0.165	9	300	50
420	0.133			0.043	1	390	17
480	0.125			0.049	2	450	22
540	0.120			0.031	1	510	16
600	0.118	9	32	0.012	0	570	7
720	0.112			0.037	1	660	24
840	0.108			0.024	0	780	19
960	0.104			0.024	0	900	22
1200	0.098	10	16	0.037	1	1080	40
1680	0.087			0.067	1	1440	97
2160	0.080			0.043	1	1920	82
2880	0.070	11	12	0.061	1	2520	154
7510	0.000			0.426		5195	2211
				$\Sigma =$	1.98	1418	2882
MEC =	715 mg/L	$\zeta =$	84 %	T_d =	1197	min	

Test number:		13		Influent Samples :				
Date =	7/12/94	Sample	Time, min	TSS,	ΔT	TSS* ΔT		
Starting Time =	13:00	1	2	11040	240	2649600		
Filling Time =	1420 sec	2	6	3684	240	884160		
Silt Fence:		3	10	3884	240	932160		
Exxon woven		4	14	3724	240	893760		
AOS =	#30	5	18	3672	240	881280		
Ψ =	0.1 sec ⁻¹	6	22	3636	220	799920		
Bulk flow:								
Head over weir =	0.106 m							
Slurry tank:								
Start =	1.850 m			Σ =	1420	7040880		
End =	1.403 m			MIC =	4958	mg/L		
Total Inflow:								
Q total =	1.64 Lps			Flume & Pond:				
V in =	2.33 m ³			Area of pond =	6.12	m ²		
Soil Added:				Width of Fence =	0.711	m		
Wt of wet solids =	27.2 kg			Undrained Vol of Tank =	0.127	m ³		
Hydraulic Data & Effluent Samples:								
Time, min	Level, m	Sample	TSS, mg/L	ΔV , m ³	TSS* ΔV , g	T _{avg} , min	T _{avg} * ΔV	
0	0							
5	0.08			-0.124	-16	3	0	
10	0.14			0.126	17	8	1	
15	0.22			0.003	0	13	0	
20	0.29	1	132	0.064	9	18	1	
24	0.352			-0.018	-34	22	0	
25	0.35			0.012	23	24	0	
30	0.34			0.061	116	28	2	
40	0.33	2	1900	0.061	116	35	2	
60	0.307	3	1032	0.141	145	50	7	
90	0.287	4	468	0.122	57	75	9	
120	0.273	5	308	0.086	26	105	9	
150	0.26			0.080	14	135	11	
180	0.25	6	176	0.061	11	165	10	
240	0.231	7	108	0.116	13	210	24	
300	0.216			0.092	3	270	25	
360	0.205	8	36	0.067	2	330	22	
420	0.195			0.061	2	390	24	
480	0.19			0.031	1	450	14	
600	0.177	9	32	0.080	3	540	43	
720	0.17			0.043	1	660	28	
840	0.165			0.031	0	780	24	
960	0.159			0.037	1	900	33	
1200	0.151	10	16	0.049	1	1080	53	
1680	0.132			0.116	2	1440	167	
2160	0.125			0.043	1	1920	82	
2880	0.118	11	16	0.043	1	2520	108	
14640	0.000			0.720		8760	6305	
			Σ =	1.48	515		7004	
MEC =	347	mg/L	ζ =	96	%	T_d =	3179	min

Test number:		14		Influent Samples :			
Date =	7/15/94	Sample	Time, min	TSS,	ΔT	TSS* ΔT	
Starting Time =	11:00	1	2	4220	240	1012800	
Filling Time =	1320 sec	2	6	8524	240	2045760	
Silt Fence:		3	10	4892	240	1174080	
Exxon woven		4	14	3884	240	932160	
AOS =	#30	5	18	3340	240	801600	
Ψ =	0.1 sec ⁻¹	6	22	3024	120	362880	
Bulk flow:							
Head over weir =	0.106 m						
Slurry tank:							
Start =	1.850 m			Σ =	1320	6329280	
End =	1.439 m			MIC =	4795 mg/L		
Total Inflow:							
Q total =	1.64 Lps			Flume & Pond:			
V in =	2.17 m ³			Area of pond =	6.12 m ²		
Soil Added:				Width of Fence =	0.711 m		
Wt of wet solids =	27.2 kg			Undrained Vol of Tank =	0.127 m ³		
Hydraulic Data & Effluent Samples:							
Time, min	Level, m	Sample	TSS, mg/L	ΔV , m ³	TSS* ΔV , g	T _{avg} , min	T _{avg} * ΔV
0	0.000						
5	0.090			-0.185	-126	3	0
10	0.188			-0.107	-73	8	-1
15	0.261			0.046	31	13	1
20	0.336	1	680	0.034	23	18	1
22	0.352			0.099	143	21	2
25	0.345			0.043	62	24	1
30	0.343			0.012	18	28	0
40	0.336	2	1440	0.043	62	35	1
60	0.326	3	1020	0.061	62	50	3
90	0.314	4	628	0.073	46	75	6
120	0.307	5	304	0.043	13	105	4
150	0.301			0.037	8	135	5
180	0.293	6	228	0.049	11	165	8
240	0.285	7	132	0.049	6	210	10
360	0.262	8	24	0.141	3	300	42
420	0.253			0.055	5	390	21
480	0.245			0.049	5	450	22
600	0.234	9	92	0.067	6	540	36
720	0.228			0.037	2	660	24
840	0.224			0.024	1	780	19
960	0.218			0.037	2	900	33
1200	0.212	10	56	0.037	2	1080	40
1680	0.196			0.098	4	1440	141
2160	0.183			0.080	3	1920	153
2880	0.170	11	36	0.080	3	2520	200
11350	0.000			1.038		7115	7385
				Σ =	1.00	322	8159
MEC =	322 mg/L	ζ =	97 %	T _d =	4004 min		

Test number:		15		Influent Samples :			
Date =	7/26/94	Sample	Time, min	TSS,	ΔT	TSS* ΔT	
Starting Time =	12:00	1	2	2770	240	664800	
Filling Time =	1525 sec	2	6	3205	240	769200	
Silt Fence:		3	10	2865	240	687600	
Mirafi A non-woven	65303	4	14	2645	240	634800	
AOS =	#100	5	18	2840	240	681600	
$\Psi =$	1.5 sec ⁻¹	6	22	2975	325	966875	
Bulk flow:							
Head over weir =	0.106 m						
Slurry tank:							
Start =	1.850 m			$\Sigma =$	1525	4404875	
End =	1.370 m			MIC =	2888	mg/L	
Total Inflow:							
Q total =	1.64 Lps			Flume & Pond:			
V in =	2.51 m ³			Area of pond =	6.12	m ²	
Soil Added:				Width of Fence =	0.711	m	
Wt of wet solids =	27.2 kg			Undrained Vol of Tank =	0.127	m ³	
Hydraulic Data & Effluent Samples:							
Time, min	Level, m	Sample	TSS, mg/L	ΔV , m ³	TSS* ΔV , g	T _{avg} , min	T _{avg} * ΔV
0	0.000						
5	0.095	1		-0.218	-110	3	-1
10	0.168	2		0.049	25	8	0
15	0.241	3		0.045	23	13	1
20	0.310	4	505	0.071	36	18	1
25	0.351	5	1530	0.245	374	23	6
30	0.342	6	1530	0.054	83	28	1
60	0.330	7	600	0.069	41	45	3
90	0.326	8	205	0.028	6	75	2
120	0.323	9	80	0.015	1	105	2
150	0.319	10	80	0.026	2	135	4
180	0.319	11	70	0.000	0	165	0
240	0.316	12	25	0.021	1	210	4
300	0.313	13	25	0.017	0	270	5
360	0.310	14	10	0.021	0	330	7
420	0.306	15	25	0.021	1	390	8
480	0.302	16	10	0.024	0	450	11
600	0.300	17	35	0.013	0	540	7
720	0.294	18	0	0.039	0	660	26
840	0.290	19	0	0.021	0	780	16
960	0.287	20	0	0.022	0	900	20
1200	0.284	21	0	0.015	0	1080	16
1620	0.271	22	0	0.084	0	1410	118
2100	0.265	23	0	0.034	0	1860	62
2880	0.255	24	0	0.062	0	2490	155
23240	0.000			1.558		13060	20341
				$\Sigma =$	0.78	483	20816
MEC =	622 mg/L	$\zeta =$	93 %	T_d =	8919 min		

Test number:		16		Influent Samples :				
Date =	8/2/94	Sample	Time, min	TSS,	ΔT	TSS* ΔT		
Starting Time =	10:00	1	2	8135	240	1952400		
Filling Time =	1525 sec	2	6	10725	240	2574000		
Silt Fence:		3	10	2365	240	567600		
Mirafi A non-woven	65303	4	14	775	240	186000		
AOS =	#100	5	18	350	240	84000		
$\Psi =$	1.5 sec ⁻¹	6	22	715	325	232375		
Bulk flow:								
Head over weir =	0.106 m							
Slurry tank:								
Start =	1.850 m			$\Sigma =$	1525	5596375		
End =	1.650 m			MIC =	3670	mg/L		
Total Inflow:								
Q total =	1.60 Lps	Flume & Pond:						
V in =	2.43 m ³	Area of pond =			6.12	m ²		
Soil Added:				Width of Fence =		0.711	m	
Wt of wet solids =	27.2 kg	Undrained Vol of Tank =			0.127	m ³		
Hydraulic Data & Effluent Samples:								
Time, min	Level, m	Sample	TSS, mg/L	ΔV , m ³	TSS* ΔV , g	T _{avg} , min	T _{avg} * ΔV	
0	0.000							
13	0.195	1	150	-0.074	-11	7	0	
18	0.263	2	115	0.059	7	16	1	
23	0.334	3	140	0.046	6	21	1	
28	0.348	4	140	0.395	55	26	10	
33	0.344	5	145	0.022	3	31	1	
38	0.343	6	145	0.006	1	36	0	
68	0.336	7	100	0.043	4	53	2	
98	0.335	8	90	0.007	1	83	1	
128	0.332	9	70	0.019	1	113	2	
158	0.329	10	50	0.015	1	143	2	
188	0.327	11	45	0.015	1	173	3	
248	0.321	12	40	0.035	1	218	8	
308	0.322	13	40	-0.004	0	278	-1	
368	0.316	14	10	0.034	0	338	11	
428	0.314	15	20	0.013	0	398	5	
488	0.310	16	15	0.024	0	458	11	
608	0.306	17	25	0.028	1	548	15	
728	0.303	18	30	0.019	1	668	12	
848	0.297	19	35	0.032	1	788	25	
968	0.294	20	30	0.022	1	908	20	
1208	0.289	21	20	0.030	1	1088	32	
1568	0.281			0.048	1	1388	67	
2100	0.274			0.043	1	1834	79	
2880	0.264	22	25	0.063	2	2490	157	
22820	0.000			1.611		12850	20699	
			$\Sigma =$	0.94	79			21164
MEC =	84 mg/L	$\zeta =$	99 %	T_d =	8297	min		

Test number:		17		Influent Samples :			
Date =	8/11/94	Sample	Time, min	TSS,	ΔT	TSS* ΔT	
Starting Time =	9:30	1	2	7228	240	1734720	
Filling Time =	1440 sec	2	6	9220	240	2212800	
Silt Fence:		3	10	6052	240	1452480	
Mirafi A non-woven 65303		4	14	6060	240	1454400	
AOS =	#100	5	18	4552	240	1092480	
Ψ =	1.5 sec ⁻¹	6	22	3780	240	907200	
Bulk flow:							
Head over weir =	0.106 m						
Slurry tank:							
Start =	1.850 m			Σ =	1440	8854080	
End =	1.370 m			MIC =	6149	mg/L	
Total Inflow:							
Q total =	1.65 Lps			Flume & Pond:			
V in =	2.37 m ³			Area of pond =	6.12	m ²	
Soil Added:				Width of Fence =	0.711	m	
Wt of wet solids =	27.2 kg			Undrained Vol of Tank =	0.127	m ³	
Hydraulic Data & Effluent Samples:							
Time, min	Level, m	Sample	TSS, mg/L	ΔV , m ³	TSS* ΔV , g	T _{avg} , min	T _{avg} * ΔV
0	0.000						
5	0.072	1		-0.073	-106	3	0
10	0.147	2		0.035	51	8	0
15	0.218	3		0.060	86	13	1
20	0.294	4		0.029	42	18	1
25	0.359	5	1442	0.096	139	23	2
30	0.348	6	1284	0.067	86	28	2
60	0.348	7	492	0.000	0	45	0
90	0.343	8	336	0.031	10	75	2
120	0.343	9	160	0.000	0	105	0
150	0.341	10	92	0.012	1	135	2
180	0.341	11	80	0.000	0	165	0
240	0.34	12	80	0.006	0	210	1
300	0.339	13	44	0.006	0	270	2
360	0.336	14	40	0.018	1	330	6
420	0.337	15	20	-0.006	0	390	-2
480	0.338	16	52	-0.006	0	450	-3
600	0.335	17	36	0.018	1	540	10
720	0.334	18	60	0.006	0	660	4
840	0.334	19	60	0.000	0	780	0
960	0.331	20	40	0.018	1	900	17
1200	0.329	21	20	0.012	0	1080	13
1620	0.328	22	24	0.006	0	1410	9
2100	0.320	23	28	0.049	1	1860	91
2880	0.312	24	12	0.049	1	2490	122
33290	0.000			1.907		18085	34483
				Σ =	0.43	315	34761
MEC =	725 mg/L	ζ =	98 %	T_d =	14847 min		

Test number:		19		Influent Samples :			
Date =	8/19/94	Sample	Time, min	TSS,	ΔT	TSS* ΔT	
Starting Time =	13:30	1	2	3740	240	897600	
Filling Time =	1875 sec	2	6	3416	240	819840	
Silt Fence:		3	10	3868	240	928320	
Mirafi B non-woven	65303	4	14	4152	240	996480	
AOS =	#100	5	18	4132	240	991680	
Ψ =	1.5 sec ⁻¹	6	22	4508	240	1081920	
Bulk flow:		7	26	4236	240	1016640	
Head over weir =	0.106 m	8	30	3680	195	717600	
Slurry tank:							
Start =	1.850 m			Σ =	1875	7450080	
End =	1.237 m			MIC =	3973	mg/L	
Total Inflow:							
Q total =	1.65 Lps			Flume & Pond:			
V in =	3.09 m ³			Area of pond =	6.12	m ²	
Soil Added:				Width of Fence =	0.711	m	
Wt of wet solids =	27.2 kg			Undrained Vol of Tank =	0.127	m ³	
Hydraulic Data & Effluent Samples:							
Time, min	Level, m	Sample	TSS, mg/L	ΔV , m ³	TSS* ΔV , g	T _{avg} , min	T _{avg} * ΔV
0	0.000						
5	0.088			-0.172	-226	3	0
10	0.164	1	1316	0.029	38	8	0
15	0.229	2	1380	0.096	132	13	1
20	0.276	3	1872	0.206	386	18	4
25	0.314	4	1992	0.261	520	23	6
30	0.350	5	1948	0.273	533	28	8
31	0.355			0.068	12	31	2
60	0.320	6	176	0.214	38	46	10
90	0.316	7	96	0.024	2	75	2
120	0.311	8	96	0.031	3	105	3
150	0.308	9	72	0.018	1	135	2
180	0.307	10	48	0.006	0	165	1
240	0.302	11	48	0.031	1	210	6
300	0.299	12	28	0.018	1	270	5
360	0.297	13	24	0.012	0	330	4
420	0.296	14	20	0.006	0	390	2
480	0.293	15	24	0.018	0	450	8
600	0.285	16	20	0.049	1	540	26
720	0.280	17	16	0.031	0	660	20
840	0.273	18	20	0.043	1	780	33
960	0.269	19	4	0.024	0	900	22
1200	0.261	20	4	0.049	0	1080	53
1620	0.245	21	0	0.098	0	1410	138
2100	0.225	23	0	0.122	0	1860	228
2880	0.193	24	0	0.196	0	2490	489
7500	0.000			1.179		5190	6119
				Σ =	1.75	1445	7193
MEC =	824 mg/L	ζ =	88 %	T_d =	2453 min		

APPENDIX E - RESULTS OF PERMEAMETER TESTS

Fabric area =		5.07	cm ²		
Standard Volume =		14,450	cm ³		
v =		1.00E-06	m ² /s		
Mirafi non-woven					
d =		#100	sieve		
d =		1.50E-04	m		
10/28/94 Mirafi non-woven, vacuumed					
h (m)	t (s)	Q/A (cm/s)	Ψ, sec ⁻¹		
0		0			
0.05	296	9.6	1.93		
0.1	177	16.1	1.61		
0.2	122	23.4	1.17		
0.3	72	39.6	1.32		
0.4	60	47.5	1.19		
0.5	53	53.8	1.08		
0.6	47	60.6	1.01		
10/31/94 Mirafi non-woven, not vacuumed					
h (m)	t (s)	Q/A (cm/s)	Ψ, sec ⁻¹		
0.05	277	10.3	2.06		
0.1	157	18.2	1.82		
0.2	93	30.6	1.53		
0.3	72	39.6	1.32		
0.4	61	46.7	1.17		
0.5	53	53.8	1.08		
0.6	47	60.6	1.01		
Amoco woven					
d =		#20	sieve		
d =		8.50E-04	m		
POA =		0.033			
11/2/94 Amoco woven, not vacuumed					
h (m)	t (s)	Q/A (cm/s)	Ψ, sec ⁻¹	V, m/s	Re
0.05	1598	1.8	0.36	0.54	459
0.1	890	3.2	0.32	0.97	825
0.2	597	4.8	0.24	1.45	1,230
0.3	457	6.2	0.21	1.89	1,606
0.4	394	7.2	0.18	2.19	1,863
0.5	357	8.0	0.16	2.42	2,056
0.6	329	8.7	0.14	2.63	2,231

Amoco woven						
d =	#20	sieve				
d =	8.50E-04	m				
POA=	0.033					
11/4/94	Amoco woven, vacuumed					
V (cm ³)	h (m)	t (s)	Q/A (cm/s)	Ψ, sec ⁻¹	V, m/s	Re
3320	0.05	300	2.2	0.44	0.66	562
5135	0.1	300	3.4	0.34	1.02	870
7610	0.2	300	5.0	0.25	1.52	1,289
Std.	0.3	418	6.8	0.23	2.07	1,756
"	0.4	383	7.4	0.19	2.26	1,917
"	0.5	334	8.5	0.17	2.59	2,198
"	0.6	306	9.3	0.16	2.82	2,399
Belton woven						
d =	#30	sieve				
d =	6.00E-04	m				
11/14/94	Belton woven, vacuumed					
h (m)	t (s)	Q/A (cm/s)	Ψ, sec ⁻¹			
0.05	849	3.4	0.67			
0.1	547	5.2	0.52			
0.2	365	7.8	0.39			
0.3	283	10.1	0.34			
0.4	243	11.7	0.29			
0.5	227	12.6	0.25			
0.6	209	13.6	0.23			
11/14/94	Belton woven, not vacuumed					
h (m)	t (s)	Q/A (cm/s)	Ψ, sec ⁻¹			
0.05	515	5.5	1.11			
0.1	355	8.0	0.80			
0.2	264	10.8	0.54			
0.3	219	13.0	0.43			
0.4	197	14.5	0.36			
0.5	176	16.2	0.32			
0.6	162	17.6	0.29			

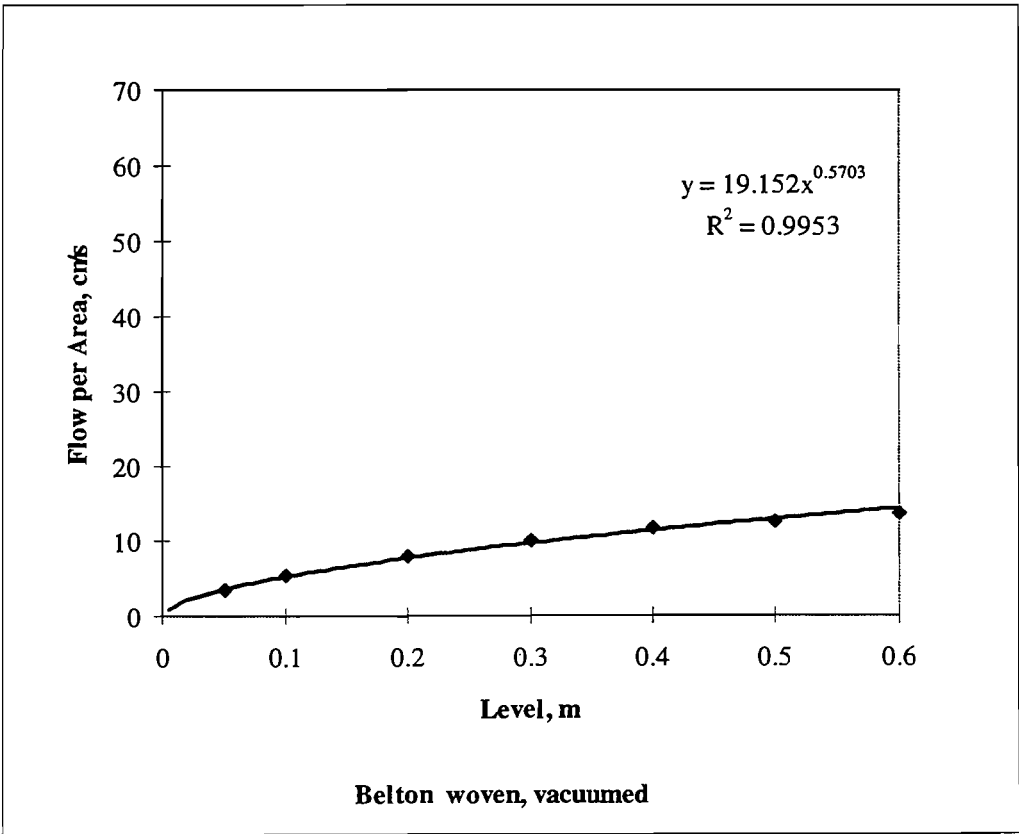
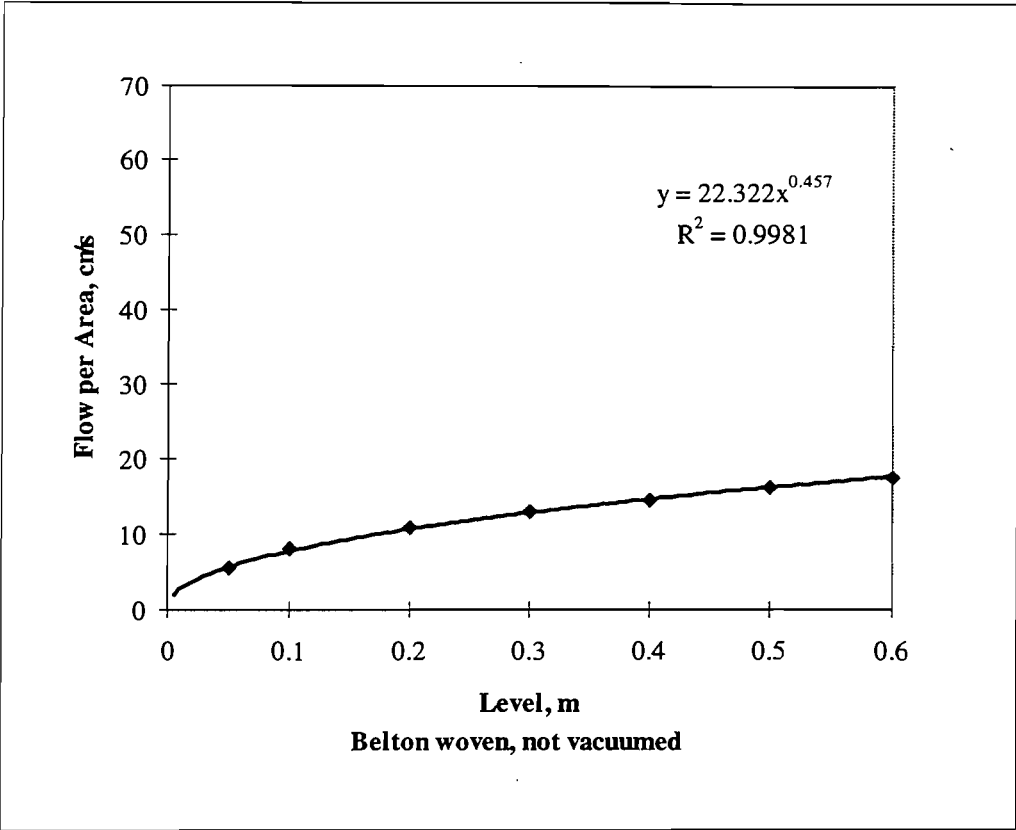

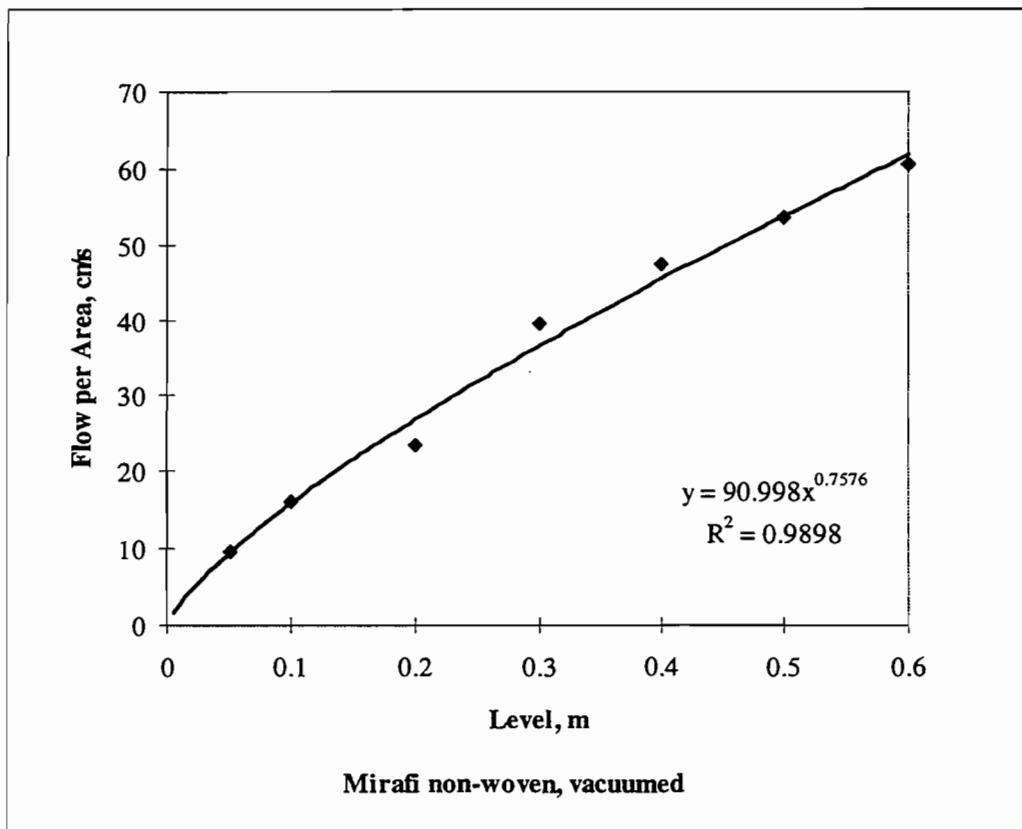
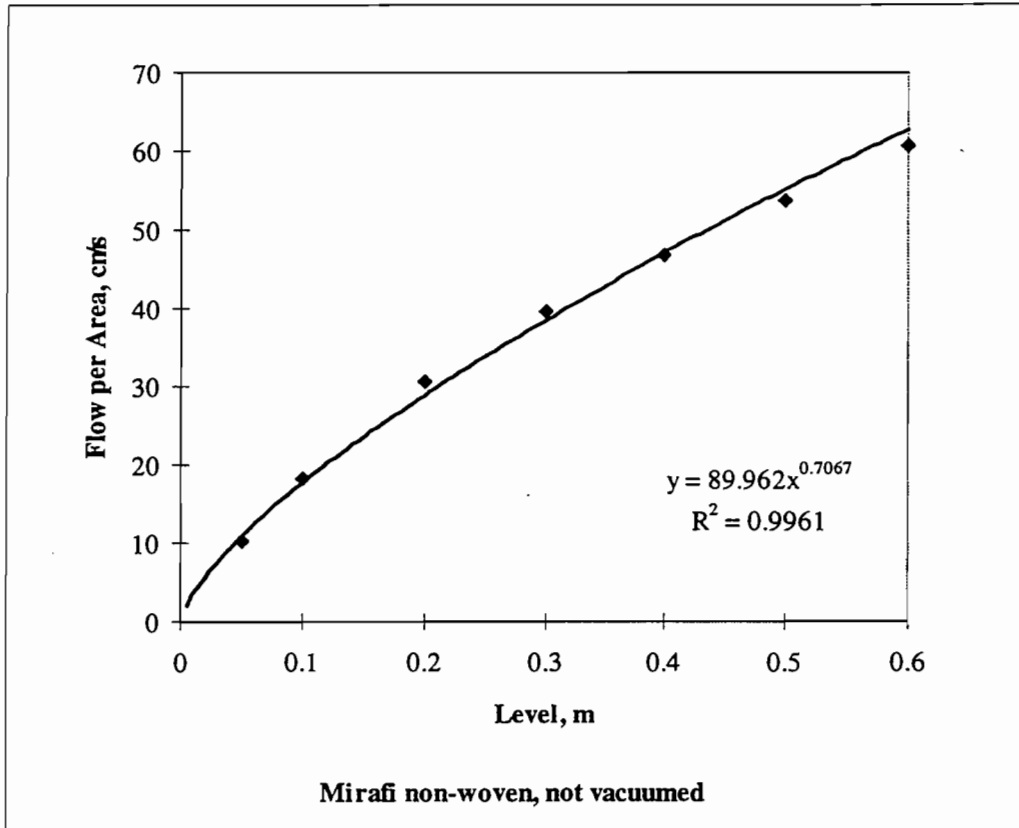

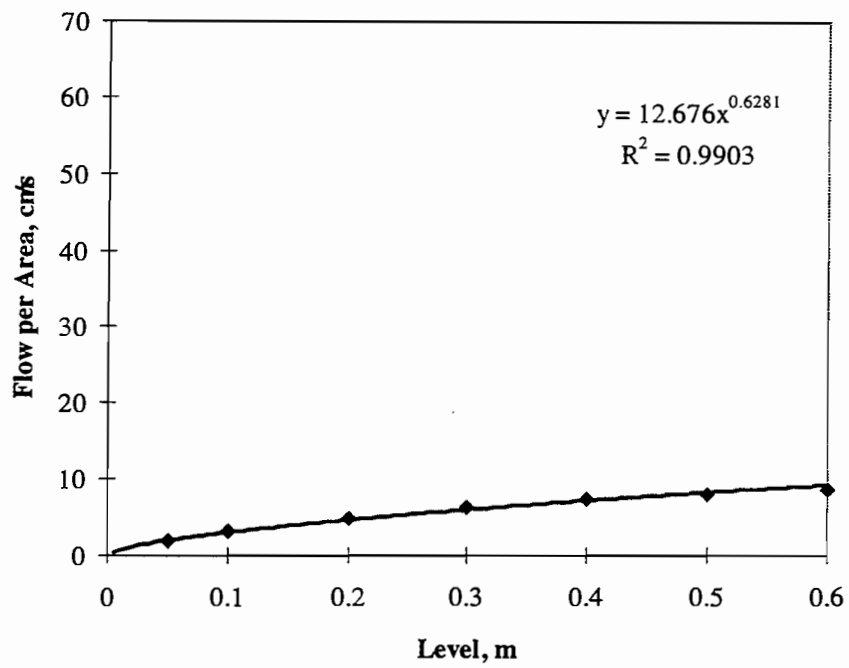

Amoco woven, not vacuumed

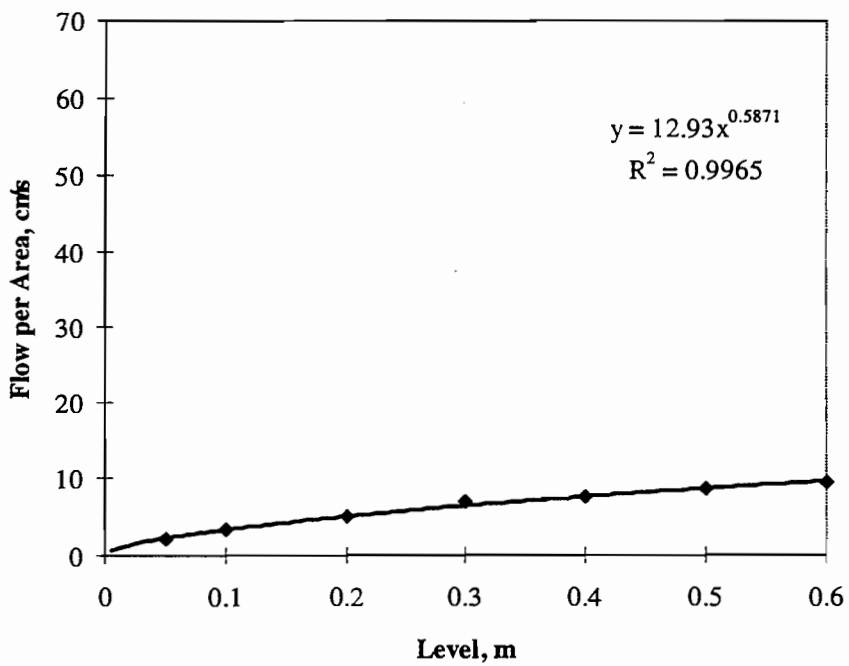

Amoco woven, vacuumed

APPENDIX F - BASE EFFICIENCY TEST

	Date =	9/17/94	Influent Samples:				
Starting Time =	10:55		Sample	Time, min	TSS, mg/L	ΔT	TSS* ΔT
Filling Time =	1020	sec	1	2	2804	240	672960
Bulk Flow:			2	6	2444	240	586560
Head over weir =	0.106	m	3	10	2940	240	705600
Slurry Tank:			4	14	3144	240	754560
Start =	1.475	m			$\Sigma =$	960	2719680
End =	1.165	m			MIC =	2833	mg/L
Total Inflow:							
Q total =	1.64	Lps			Flume & Pond:		
V in =	1.57	m ³			Area of Pond =	6.12	m ²
Soil Added:					Width of Flume =	0.762	m
Wt of wet solids =	25.4	kg			Undrained Vol of Tank =	0.127	m ³
Hydraulic Data & Effluent Samples:							
Time, min	Level, m	Sample	TSS, mg/L	$\Delta V, m^3$	TSS* $\Delta V, g$		
0	0						
1	0						
2	0						
3	0.012	1	1856	-0.102	153		
4	0.014			0.086			
5	0.014			0.098			
6	0.016			0.086			
7	0.015			0.105			
8	0.016	2	2070	0.092	980		
9	0.017			0.092			
10	0.017			0.098			
11	0.016			0.105			
12	0.016			0.098			
13	0.017	3	2294	0.092	1819		
14	0.017			0.098			
15	0.016			0.105			
16	0.014			0.111			
17	0.018			0.074			
18	0.009			0.055			
19	0.007			0.012			
20	0.001			0.037			
21	0.003			-0.012			
22	0			0.018			
			$\Sigma =$	1.35	2952		
MEC =	2189	mg/L	$\zeta =$	34	%	Velocity =	0.14 m/s