

PROGRESS REPORT

SUMMER 1993

TEXAS MOBILE LOAD SIMULATOR

FOREWORD



*R. G. Welsch, P.E.
Deputy Director for Field Operations
Texas Department of Transportation
March 1993*

The Texas Department of Transportation (TxDOT) is currently developing an accelerated vehicle simulator for pavement testing throughout the state. This development is in line with worldwide trends seeking to enhance the ability of pavement engineers to predict pavement behavior and to optimize new designs and rehabilitation strategies.

Toward these efforts, TxDOT has chosen to develop the Texas Mobile Load Simulator (TxMLS), which has been provisionally patented. An operational model has been acquired, and development of the full-scale prototype is nearing design completion. Construction of the full-scale prototype began in fall 1992 and is expected to be completed by late summer 1993. This report gives some of the technical details and capabilities of the TxMLS.

The unique design of the TxMLS affords it the ability to simulate real truck traffic conditions more closely than any other known device of its kind. This ability will allow TxDOT to contribute substantially to pavement engineering knowledge. Any organizations interested in more information about the project are welcome to contact the Department.

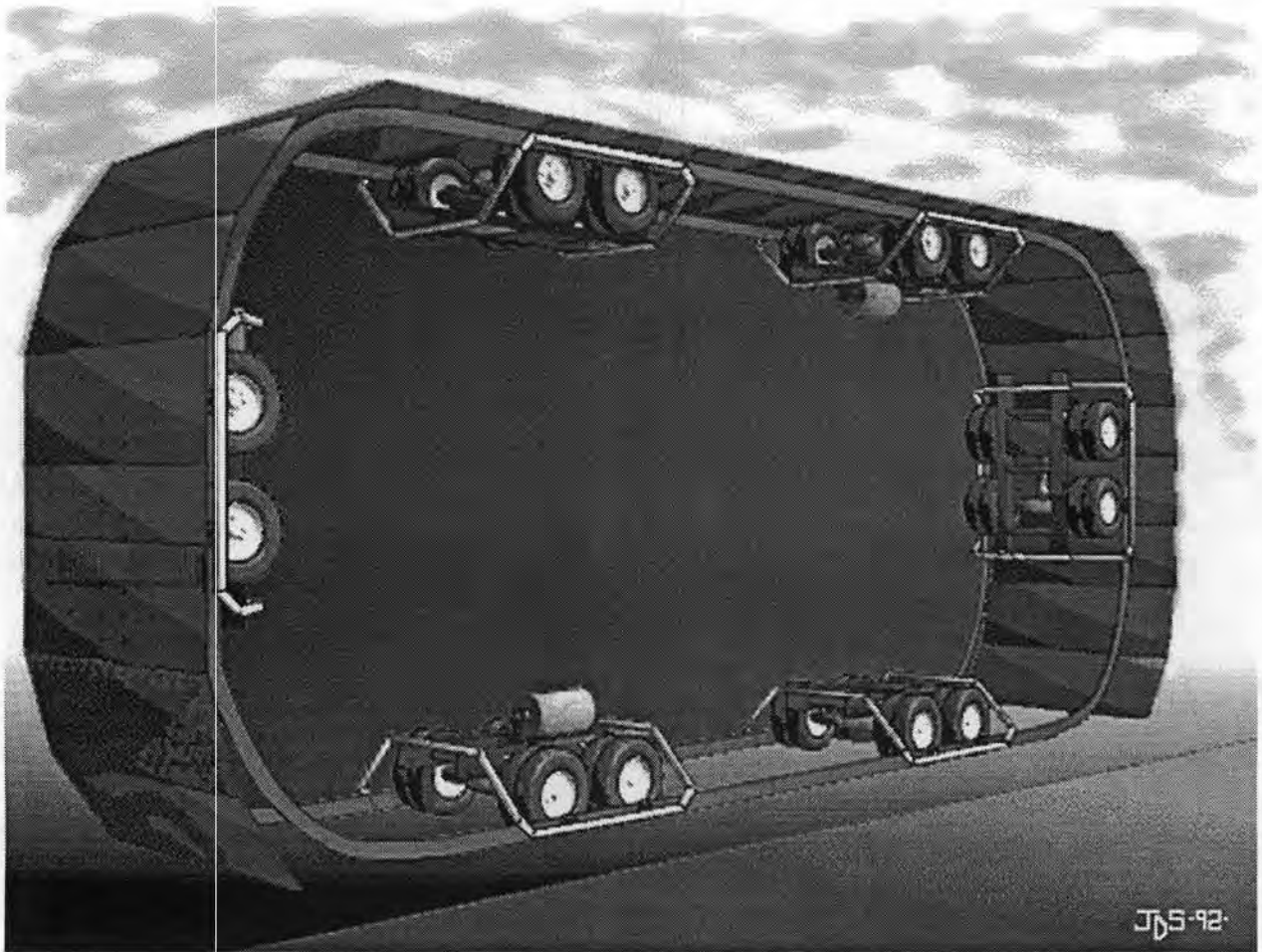

TEXAS MOBILE LOAD SIMULATOR

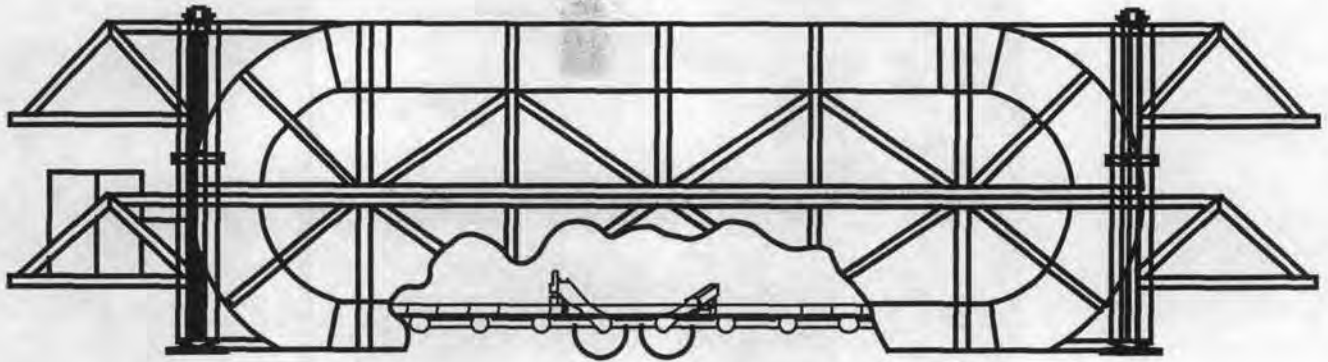

ACCELERATED PAVEMENT TESTING (APT) USING THE TEXAS MLS

A new testing machine named the Texas Mobile Load Simulator (TxMLS), which was based on a provisional patent owned by Dr. Frederick Hugo

Based on a proposal submitted by the Center for Transportation Research (CTR) at The University of Texas at Austin, a research program was initiated by the Texas Department of Transportation (TxDOT) through which CTR was to develop a device for carrying out full-scale tests on pavements using APT. After the first phase of the study, TxDOT decided to develop a new testing machine named the Texas Mobile Load Simulator (TxMLS), which was based on a provisional patent owned by Dr. Frederick Hugo. The purpose of this progress report is to relay technical information on the TxMLS to other transportation departments and interested parties.

The TxMLS is a mobile testing device capable of accelerated simulation of real traffic loading on any selected pavement section. Accelerated testing is principally achieved by increasing the number of axles and/or the rate of application. It is also capable of accelerated testing by overloading. The pavement sections to

be tested can be either existing in-service roads or specially constructed test sections.

The TxMLS is a unique system featuring the energy-saving, closed-loop concept. Rotation of truck bogies linked by a chain-type mechanism around the stationary frame is achieved using electric motors on two drive axles transforming rotation of the wheels in contact with the pavement to translation of the chain around the frame.

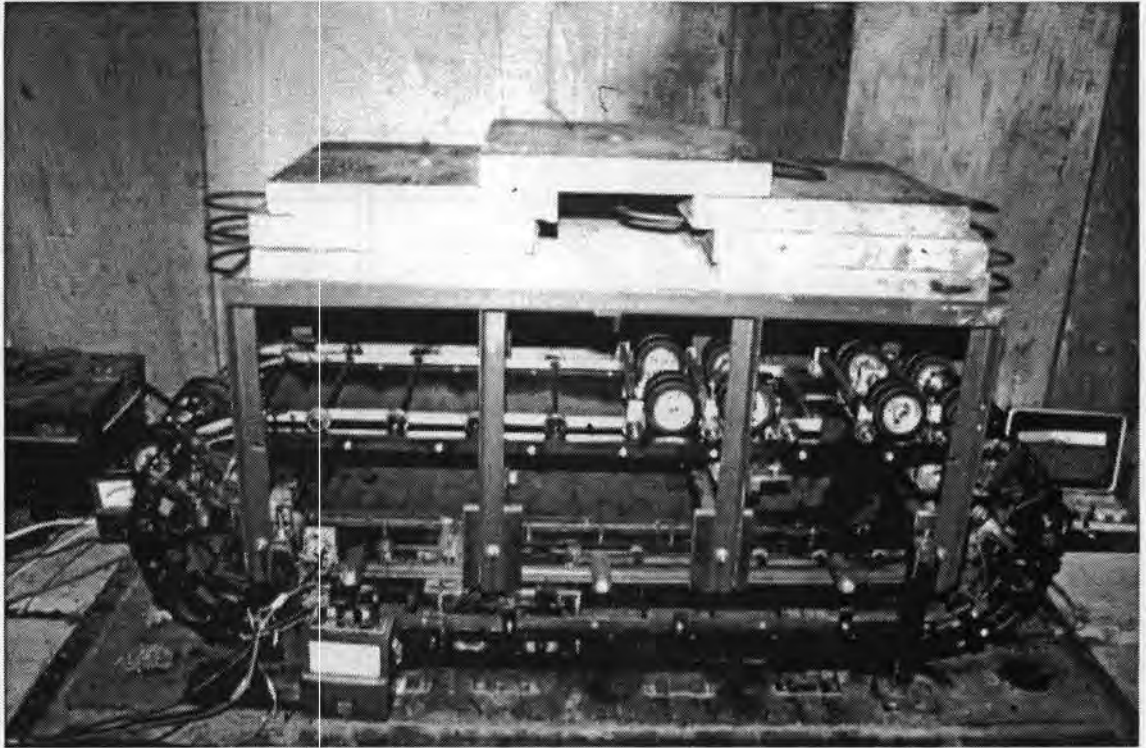

MODEL TEXAS MOBILE LOAD SIMULATOR

The model proved to be an important component of the prototype development strategy

As a first step CTR acquired a 1:10 scale model of the proposed TxMLS on behalf of TxDOT. The prime reason for this step was to evaluate the electrical system and the mechanical components for use in the design of the prototype. However, the model may also be utilized:

As a demonstration exhibit to generate interest for prototype development,

To evaluate model pavements and materials, and

To perform relative comparisons of new material specifications.

The Model MLS uses specially cast tires that have a down-scaled resilience comparable to the resilience of actual truck tires. The suspension springs on the model are similarly down-scaled. Other features of this model include

the option of selecting any combination of axle configuration, limited lateral wheel distribution, and electric motors on any single or dual set of axles for testing.

The model proved to be an important component of the prototype development strategy, even though some of the aspects of the prototype (such as the mobility options) cannot be evaluated with the current model.

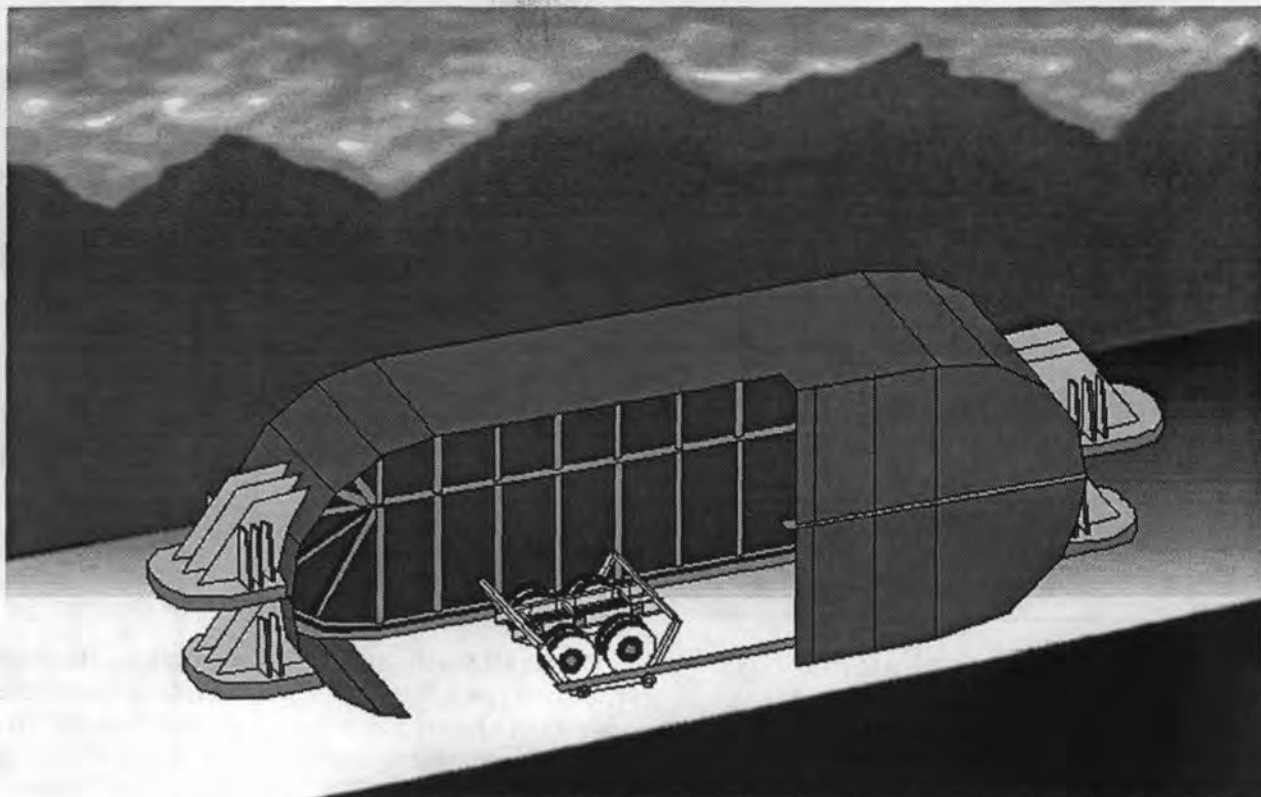

TxMLS PROTOTYPE

The MLS consists of many off-the-shelf components as well as several specially designed and engineered components

Though the detailed design of prototype components fell outside the scope of the 1988 TxDOT study, conceptual designs and calculations were made to evaluate the feasibility of the machine and its operational components. The conceptual study was followed with a design contract with an engineering services company. This contract was terminated in the general design phase to proceed with a detailed design and building contract with VMW Industries, Victoria, Texas. The MLS consists of many off-the-shelf components as well as several specially designed and engineered components.

The main components of the MLS are:

- Six tandem truck bogies with suspension and frame rails;
- Two electric motors with drive axles;
- Six load frames called "bogie carriages" that force the bogies into place;
- A chain that connects the bogie carriages;
- A control system to run the motors and monitor the bogies;
- A load rail and load wheels to apply force to the bogie carriages;
- A closed-loop ramp on which the bogies roll when not in contact with the pavement;
- The superstructure that holds the system together; and
- Four jackscrews that raise and lower the structure.



TRUCK BOGIES

There are at least four basic suspension types available for dual axles on trucks

The TxMLS will use actual off-the-shelf truck bogies consisting of chassis frame rail elements, suspension systems, axles, wheels, and tires. The term "bogie" is used by some truckers when referring to these truck tandem axle units. The basic configuration of the TxMLS typically calls for 6 bogies (12 axles) symmetrically placed around the loop.

There are at least four basic suspension types available for dual axles on trucks, namely the four-spring, air-bag, Mack Camelback, and walking-beam. Although the four-spring is currently the most prevalent suspension type used for over-the-road trucking, the air-bag is gaining popularity in the trucking industry. The walking-beam bogie has different dynamic response characteristics than the four-spring system. The four-spring bogie allows a great number of spring systems to be incorporated, including air springs. The first TxMLS prototype will use the four-spring suspension.

Two bogies will be powered while the other four will

be trailing. In addition to the standard items listed above, the powered bogies will also incorporate an off-the-shelf gear set and electric motor. Only minor modifications will be made to the bogie for attachment to the load transfer frame, sometimes referred to as the bogie carriage or saddle.

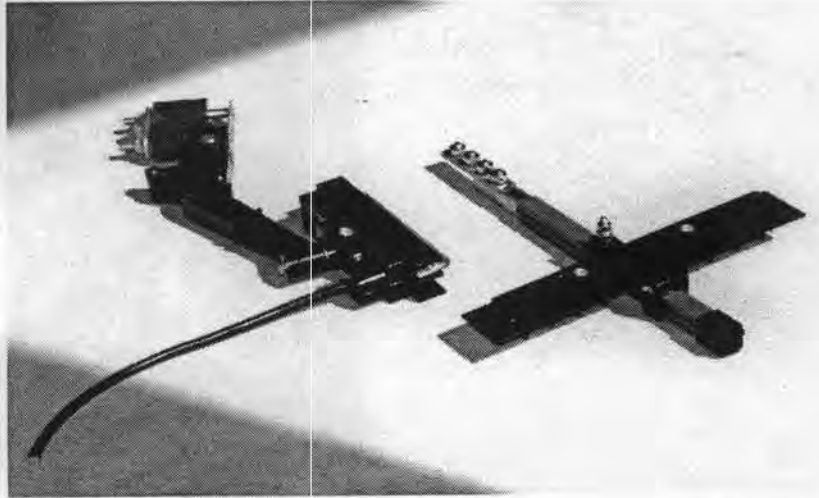
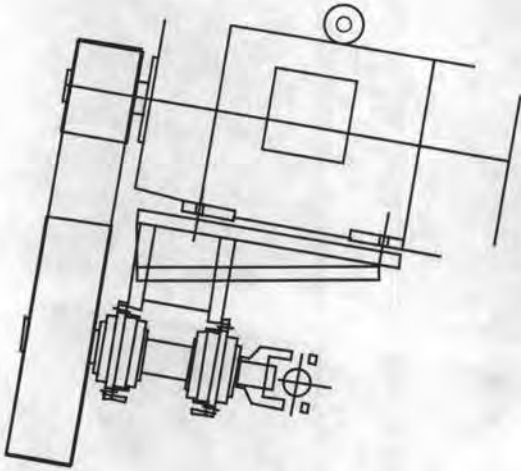

ELECTRIC MOTORS

The implication of a perfectly symmetrical or balanced system is that power can be reduced to only that necessary to overcome frictional resistance

The figure illustrates the mounting position of the electric motors. The motors will draw their power from a power rail built into the main structure. The speed (or torque) of the motor will be controlled by variable frequency drives (VFD). The VFD will allow control of speed (or torque) of the bogies. The electric motors will engage the bogie gear unit via a belt drive system. Thus, the drive axles will simulate exactly the drive mechanism of trucks on the road.

The implication of a perfectly symmetrical or balanced system is that power can be reduced to only that necessary to overcome frictional resistance, once the intended rotation speed has been reached. Motor sizes are governed by the inertia of the total chain system, the amount of friction that will be generated, gear ratios, the time required for the necessary velocity to be achieved (start-up acceleration), and by the amount of grade simulation desired. Friction will consist of chain friction, steel-wheel-on-steel-rail friction, and rubber-tire rolling resistance on pavement surface.

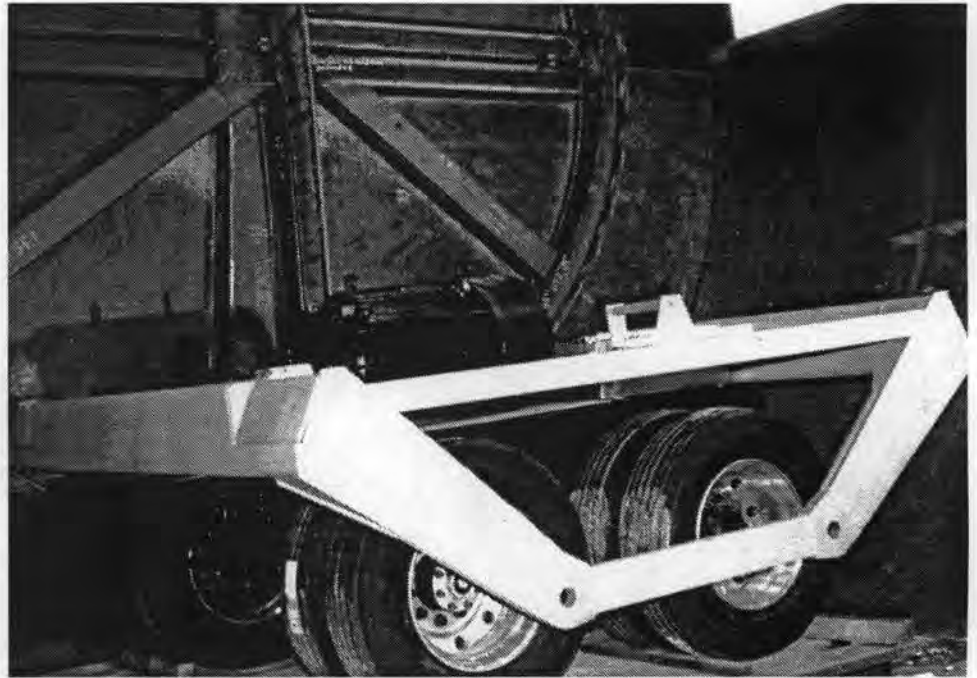

LOAD TRANSFER FRAME (“BOGIE CARRIAGE”)

The main purpose of the “Bogie Carriage” is to provide load transfer from the main structure through the load rail

This figure shows the layout of the “bogie carriage” for the TxMLS prototype. The design featured here is comparable to the construction of the moving load frame of the TxMLS model. The main purpose of the bogie carriage is to provide load transfer from the main structure through the load rail. The bogie is attached to the bogie carriage with an adjustable attachment device. The bogie carriage adjustment is used to vary the load on the bogie against the load rail (since the load rail does not move).

CHAIN MECHANISM

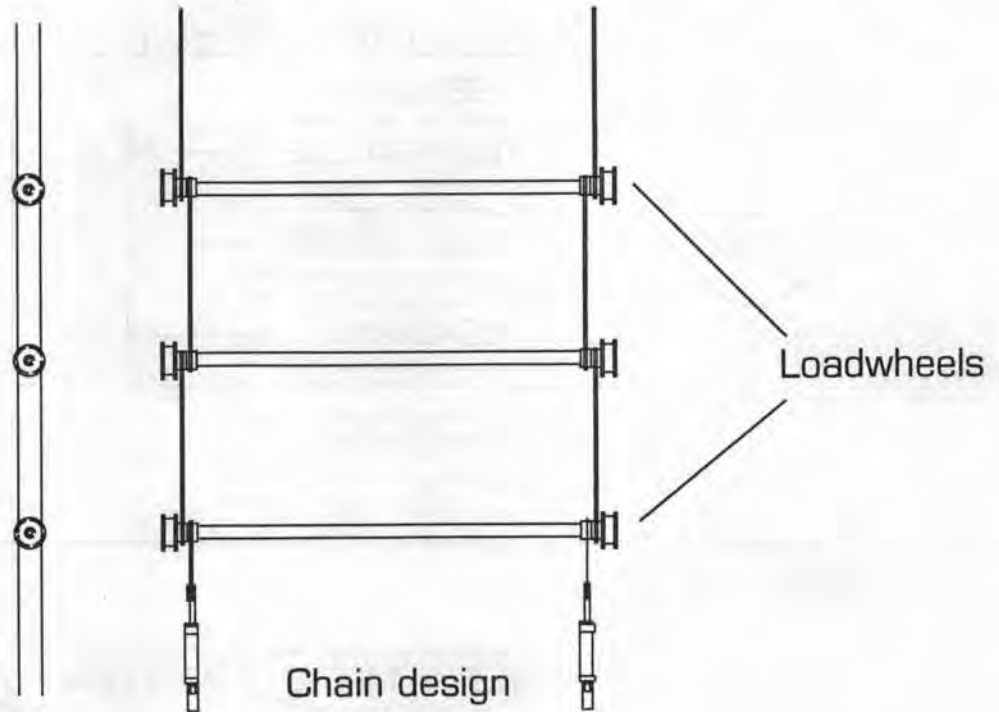

Balance will result in the exertion of minimal longitudinal and vertical forces on the supports of the structure

The "bogie carriages" are connected to each other by a chain mechanism and thus each bogie carriage is also a link in the chain. The chain is designed with the load wheels and bogie carriage as principal members. Each link is 48 inches center to center of load wheels. The chain has cross members at each link to resist torque. The design of the chain length was dependent upon the placement of the load wheels in relation to the center of gravity of the combined bogie and bogie carriage.

The rotating masses of the MLS generate significant centrifugal force. These forces are a limiting factor in the design based upon speed and mass of the bogie and bogie carriage. These centrifugal forces are carried by the continuous closed ramp. The MLS is designed to withstand 20 mph normal speeds, with a capability to increase to 25

mph maximum speed. The speed is infinitely controllable and programmable within the minimum and maximum limits. Minimum speeds are dependent upon the geometry of the bogie center of gravity (CG) and the load on the bogie. Significant changes in the bogie CG could be a limiting factor on both minimum and maximum allowable speeds.

The bogie layout was designed symmetrically in that the forces on the ramp on one end are balanced by an approximately equal force on the ramp on the opposite end, and as one motor is going up the ramp the other is coming down the other end with a balance of vertical forces. This balance will result in the exertion of minimal longitudinal and vertical forces on the supports of the structure, a condition that maximizes stability and decreases the possibility of resonance during testing.

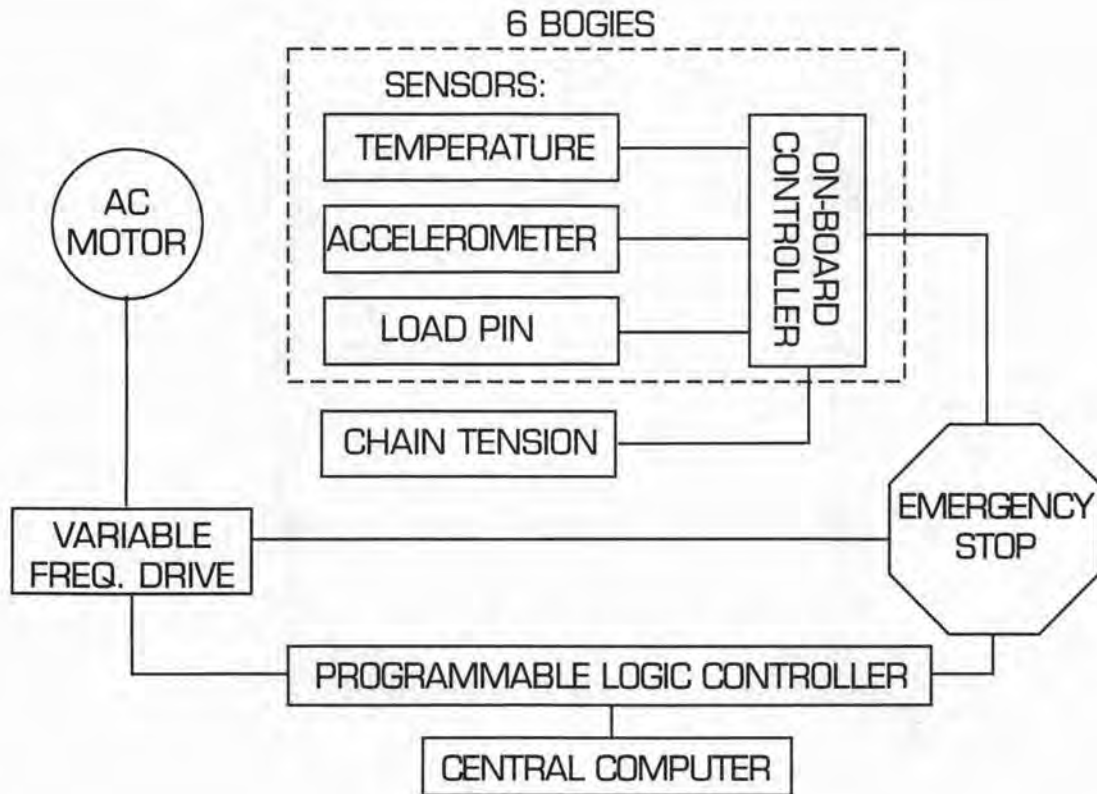

COMPUTER CONTROL SYSTEM

The control system is designed to integrate completely with the data acquisition system

A computer control system was designed to control the speed and torque of the motors. Automatic shut-off was designed with a system that monitors each bogie continuously. Sensors are located on each bogie to measure accelerations, temperature, acoustical signature, and the load applied at each of the four corners of the bogie.

Any impending failure that triggers the limits programmed on any one of the sensors will result in immediate shut down. The system allows for trouble shooting by individual sensor; reprogramming or recalibration is possible for each individual sensor as well.

The entire MLS can be controlled from an onboard

touch console or from an identical touch screen located in the control trailer. The control system is designed to integrate completely with the data acquisition system.

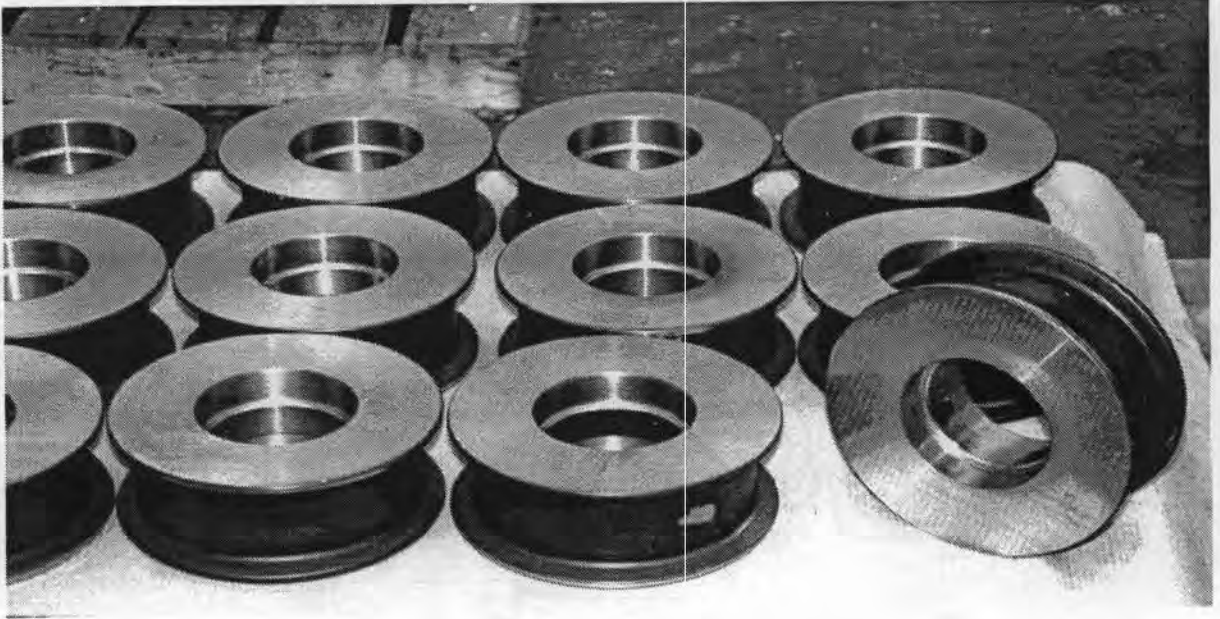

LOAD WHEELS

Specially designed load wheels were needed for required specifications

The load will be transferred from the rigid load rail to the "bogie carriage" through the steel load wheels. The load wheel connection points also serve as hinges in the chain mechanism. The use of off-the-shelf crane wheels was analyzed, but specially designed load wheels were needed to meet the required specifications.

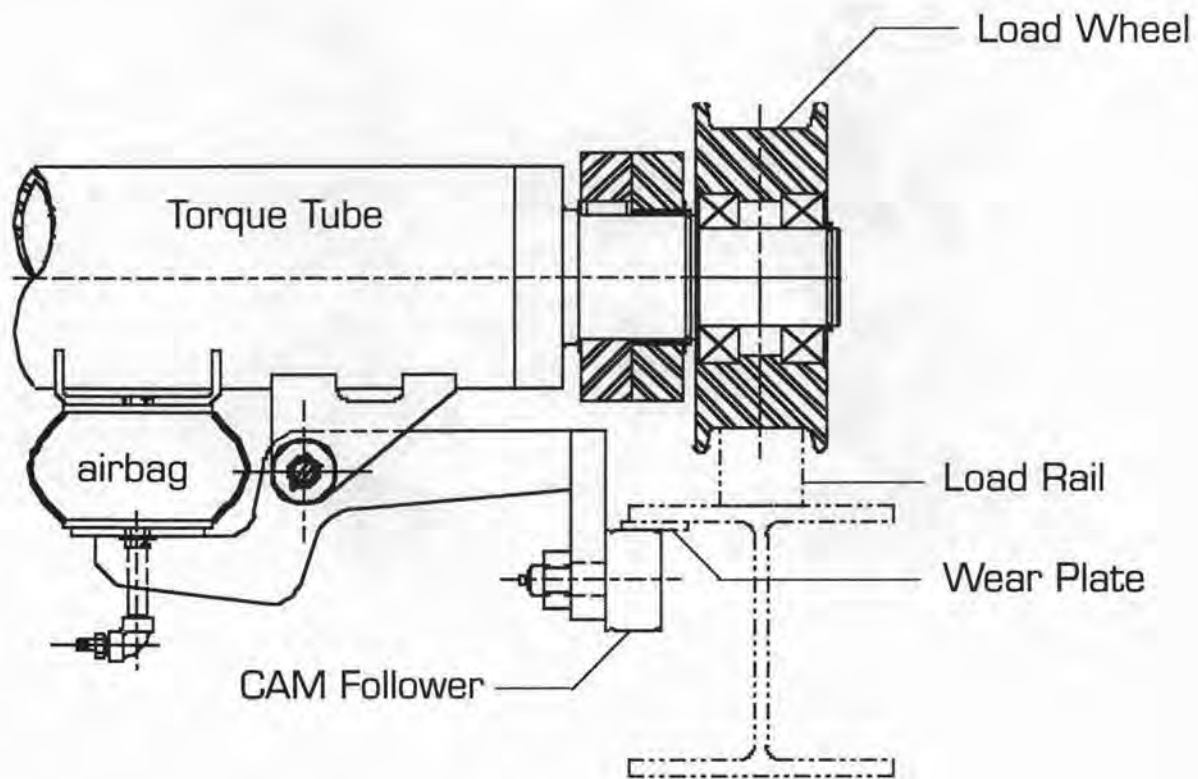

LOAD RAIL

The deflection requirements for the rail are such that upward forces caused by moving loads on the pavement should not generate deflection variations greater than a predetermined tolerance

The load rail, shown above, indicates the loading mechanism that exists in the TxMLS. It is a rigid element spanning the length of the straight section. The deflection requirements for the rail are such that upward forces caused by moving loads on the pavement should not generate deflection variations greater than a predetermined tolerance, as the number and positions of wheels between the load rail and the pavement vary. Spacing of supports from the main structure to the load rail must be governed by this deflection criteria. A limit of 5% or less change in deflection of the load rail subjected to 126% of normal axle loads is envisioned.

The load rail poses a challenge in fabrication because of the significance of the dimensional accuracy required, the geometry of the two half-circle curves, and the great strength and rigidity required of the load rail. Initial investigation looked into the feasibility of using conventional rails and having members rolled or bent into shape. However, the final solution required that the load rail be fabricated and milled into shape.

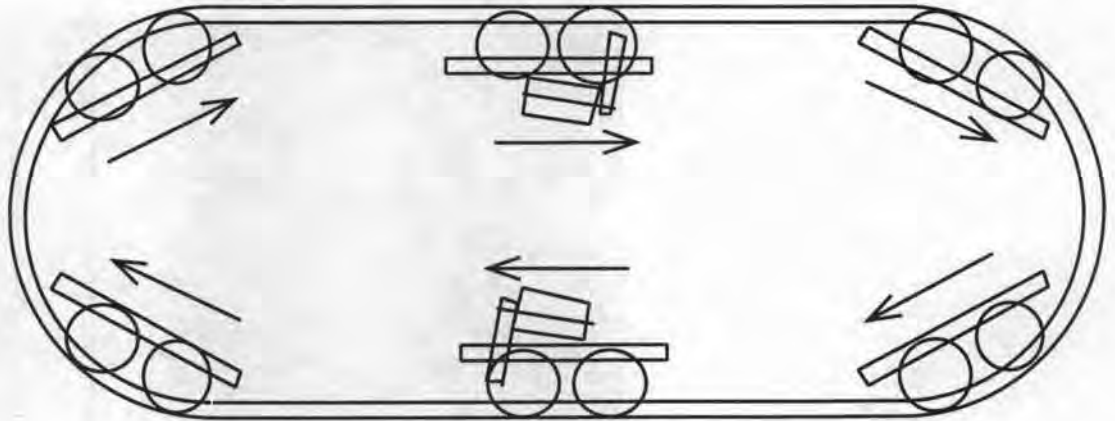

CLOSED-LOOP RAMP

The ramp system permits the simulation of vehicle resistant forces such as steep grades and wind

A closed-loop ramp concept was selected for its many advantages. The most notable advantage from the TxDOT and CTR viewpoint is safety. The second most notable advantage is dynamic effects. The bogie is continuously under load throughout the loop; therefore the fatigue loading is reduced and the dynamic loads imparted by the device to the pavement are minimized. Other advantages are: (1) reduction of centrifugal forces on the chain, (2) increased life of the bogies, (3) longer effective length of the test section, (4) containment of noise, and (5) ability to simulate accelerated environmental cycles.

The safety advantages of the fully enclosed loop design were sufficient to warrant the use of this concept. This enclosure will prevent potential flying debris from striking passing vehicles and pedestrians. It will also prevent curious onlookers from accidentally injuring themselves by getting too close to the machinery during operation.

The ability of the ramp to handle the large centrifugal forces reduces the forces on the chain, thereby allowing for a more reasonably sized chain mechanism. The ramp will increase the life of the bogies by preventing them from suffering a sudden impact when entering under the load rail. This impact is eliminated by keeping the bogies under load at all times. By eliminating the impact to the bogie when entering under the load rail, the ramp also increases the effective length of the test section for measurement and data collection purposes by providing a longer section without artificially introduced dynamic loads.

The closed-loop system provides for the containment of noise. Although not planned for the first prototype, this enclosure also allows the TxMLS to simulate environmental conditions such as seasonal temperature and rainfall cycles within the contained structure. A certain degree of environmental control can be achieved with

the addition of heating and cooling equipment. Built-in water sprays can provide rainfall simulation.

The ramp system permits the simulation of vehicle resistant forces such as steep grades and wind. On future prototypes, changing degrees of friction may be imposed on bogies by various means when they are in contact with the closed metal ramp, allowing for an increased simulation of longitudinal shoving. The shoving action can also be increased by having fewer drive axles, which will increase the amount of friction to be overcome per drive axle at the same speed. This ability to resist also has the potential (on future prototypes) to allow for some power regeneration thereby reducing operating costs.



SUPERSTRUCTURE

The superstructure is composed of two pseudo-plate girders connected by lateral cross members

The primary function of the superstructure is to transfer the deadweight of the TxMLS to the bogies while maintaining rigidity and shape. It must be capable of surviving millions of cycles of vibration without failure. It must also maintain its rigidity during transport.

The superstructure is composed of two pseudo-plate-girders connected by lateral cross members. The two large pseudo-plate-girders on each side also serve as containment for safety, noise, and environmental simulation as discussed.

JACKSCREWS

The jacks are used to raise each of the halves of the MLS and lower them to the testing position or onto the specially constructed travel trailer and dolly

Four 20 foot jackscrews connected to the upper half of the MLS are used to raise and lower the structure. To change the load on the pavement, the load rail, which is rigidly attached to the structure, can be forced lower or higher, resulting in higher or lower forces transmitted from the suspension to the pavement surface. An automated jacking system with a two-speed motor is used to make these adjustments. As illustrated, the jackscrews consist of two 20 foot lengths of 12-inch tubing connected to a screw actuator.

For transport, the MLS is too tall to travel unrestricted on the Texas highway system. The jacks are used to raise each of the halves of the MLS, separate the top and bottom halves, and lower them to the testing position or onto the specially constructed travel trailer and dolly. The jackscrews must also be removed for highway travel to meet height restrictions.

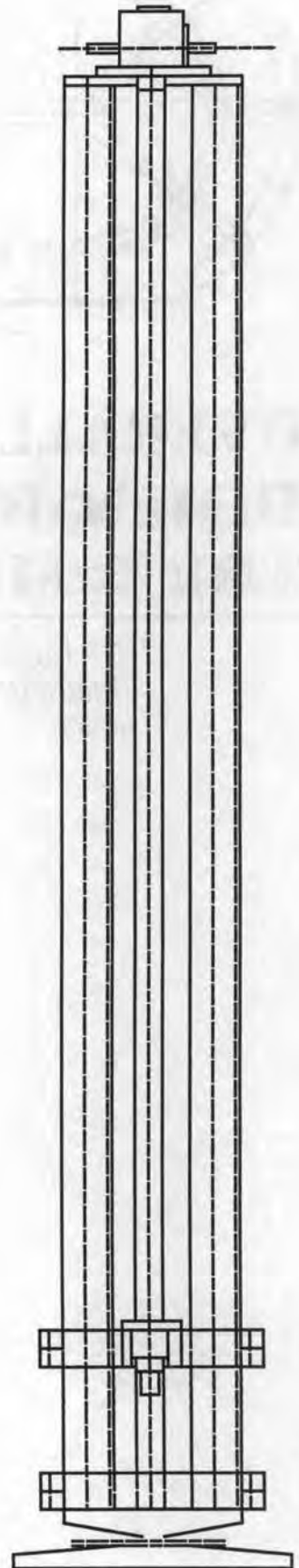

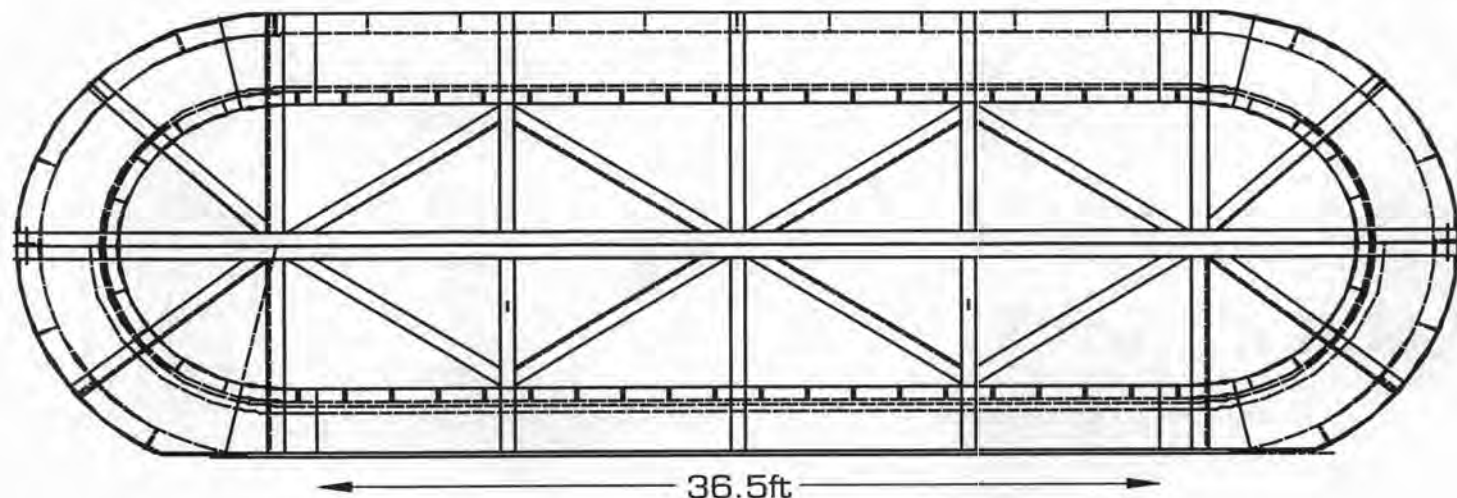

OVERALL DIMENSIONS OF THE TxMLS

The length is primarily dictated by the design test section

Overall Width (W), 12 ft. 6 inches (150 in.): The normal width of a heavy vehicle traveling without a permit on Texas highways is 102 inches. In order to provide the necessary lateral wheel distribution, additional width will have to be built into the permanent width of the machine. The width increase (to 144 inches) is expected to provide increased stability for the machine, both in transportation and in testing.

A standard truck has a width of approximately 8 ft. (96 in.). Based on comparisons of lateral load distributions of 31.5 inches for the Australian Accelerated Loading Facility (ALF) and 60 inches for the South African Heavy Vehicle Simulator (HVS), the TxMLS has been designed to distribute the load over a width of 24 inches. Because failure to provide adequately for lateral load distribution may result in

erroneous pavement response measurements, the TxMLS designers recommended that the overall width be set between 132 inches and 168 inches depending on other structural components.

Overall Length (L), 86 ft. 5 inches (1038 in.): The length is primarily dictated by the design test section length plus twice the protrusion of one of the semi-circular end ramps plus the end sections which are needed to transport the TxMLS on the highway.

Overall Height (H) 22 ft. 6 inches (270 in.): The overall height of the machine during testing is dictated by the geometry of the parabolic end ramps. For transport, the height will be equal to or less than 13.5 ft. This is accomplished by dividing the machine into sections as described in the next section.

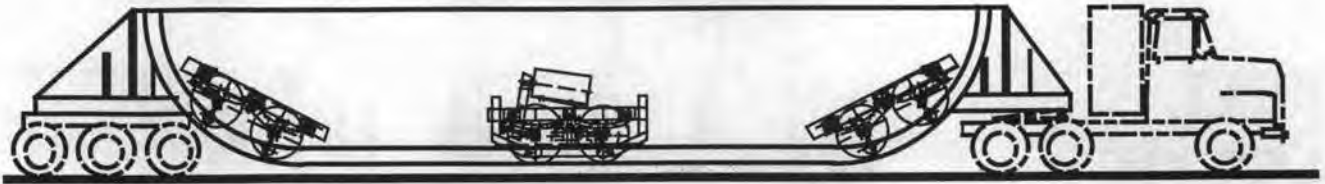
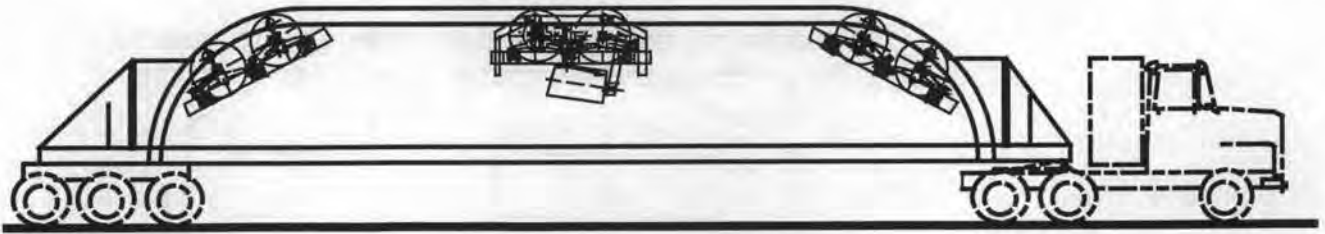

TRANSPORTATION METHOD

The lower half is backed into position and mated with the upper half

The design of the TxMLS has specifically addressed the time-consuming task of site establishment. Because the assembled TxMLS exceeds legal heights, the transportation configuration for long-haul transport will include not only the reduction in height for transport, but also the safety and ease of assembly and disassembly. The length, width, and weight parameters will exceed legal unpermitted limits; however, each parameter will be within permitting limits. Four 20-foot jackscrews attached to the upper half of the MLS will be used to raise and lower the MLS.

Operational setup includes placement of the upper half of the MLS in position and raising it to full height. The lower half is then backed into position and mated with the

upper half. When both halves are bolted together the MLS is raised off the transport trailers and set into testing position with the jackscrews. During testing, if the MLS needs to be moved for FWD testing of the test section, the MLS can be moved short distances on the transport trailers all in one piece.

TOTAL MASS OF BOGIE CARRIAGE AND TRUCK BOGIE

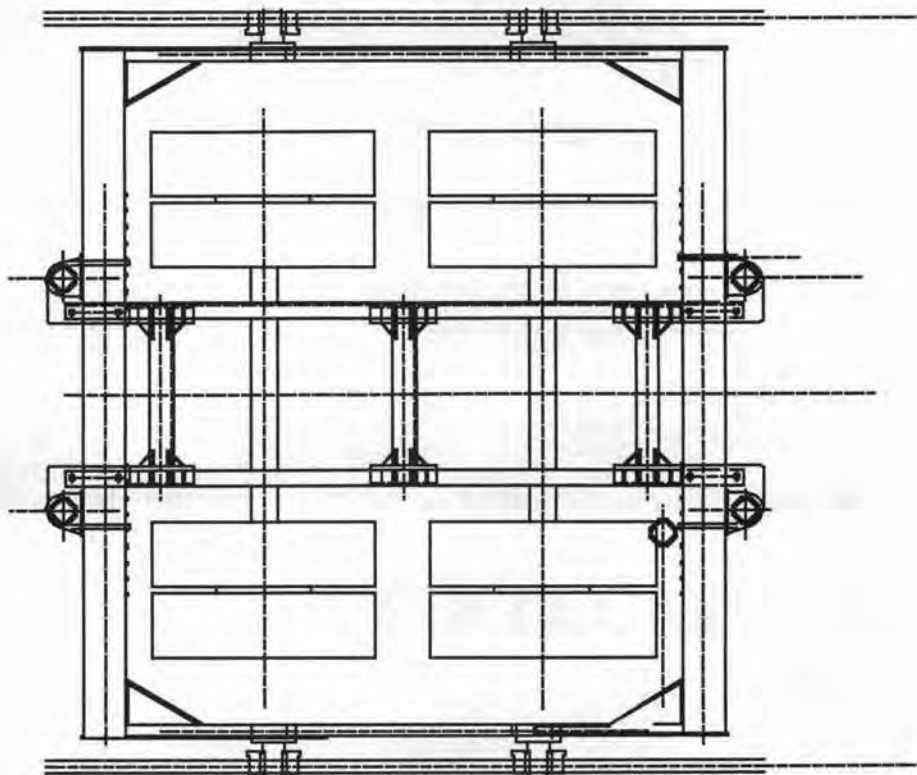

The total mass of the powered bogie is 8,800 pounds

The total mass of the moving frame is important in the calculation of the forces that will be exerted on the chain through rotation. Dynamic effects can be minimized by placing the frames in a symmetrical configuration. Nevertheless, shear forces on the main frame will have to be considered as well as the repetitive fatigue loads. The total mass of the powered bogie is 8,800 pounds and the trailer bogies are approximately 4,400 pounds each. The mass of the bogie carriage is approximately 3,000 pounds each.

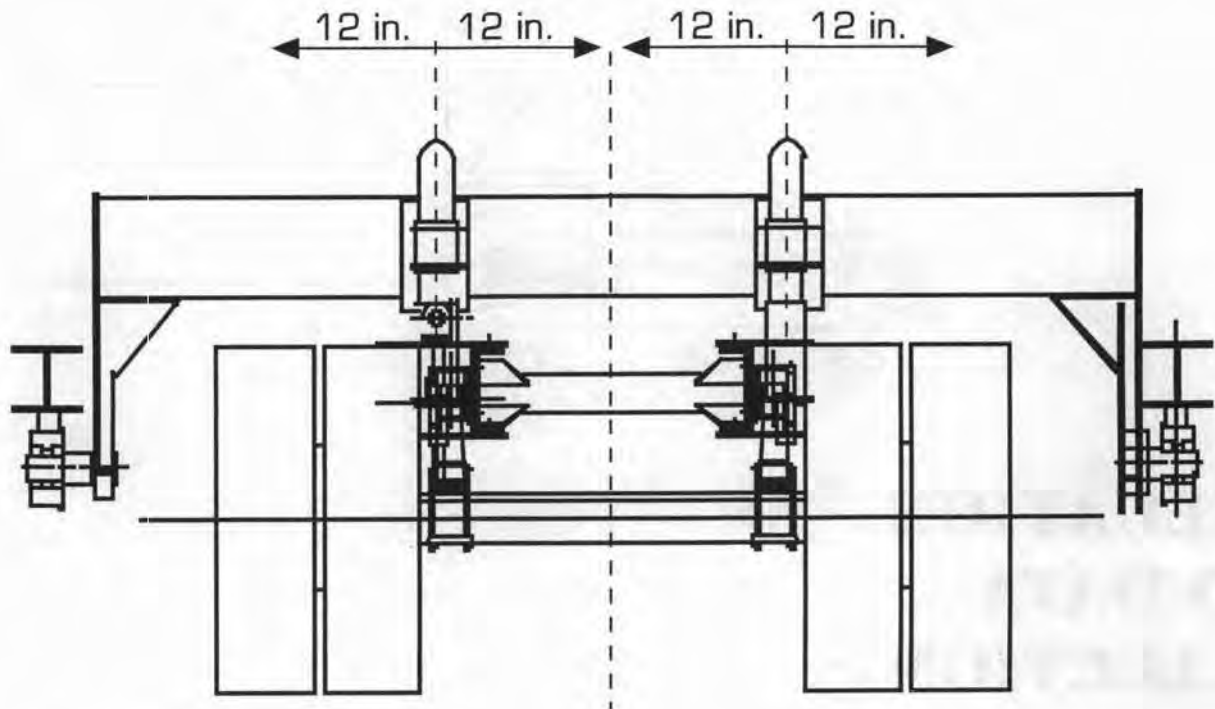

TxMLS OPERATION

The MLS is designed such that the six bogies can be placed in the same alignment and distributed in a pattern up to 12 inches either side of center

The primary objective of accelerated traffic simulation is to apply as many equivalent single axle loads (ESAL) as possible in a given time. The MLS primarily uses legally loaded 34,000-pound tandem axles using a six-bogie configuration for a total of twelve axles. This configuration is based on such factors as deflection basin influences, following distances for adequate pavement recovery time, and degree of overloading. Other axle configurations may be selected, provided some symmetry is maintained (if possible). Provisionally, a maximum of 16 axles is possible. Use of

either single axles or tandem axles will require a different bogie design (one that would fit the current bogie carriage).

The MLS is designed such that the six bogies can be placed in the same alignment and distributed in a pattern up to 12 inches either side of center. This adjustment is done manually to simulate the wander or distribution of normal truck traffic on highways.

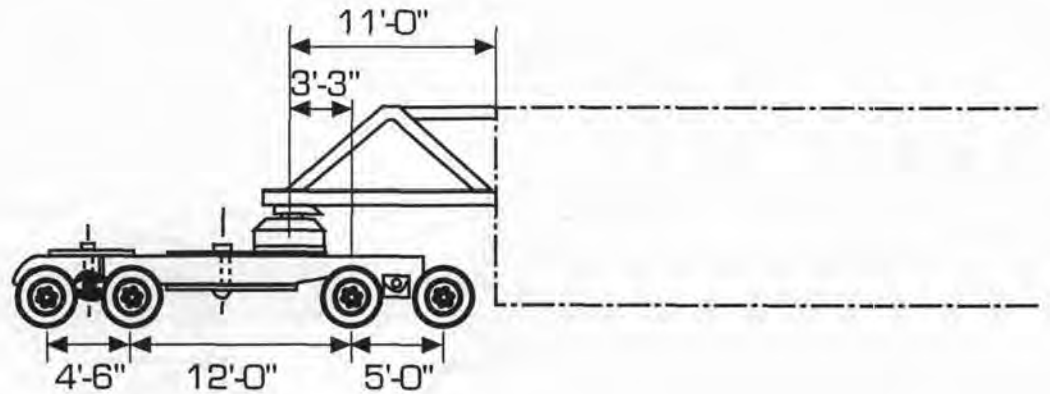

EVALUATION AND DATA COLLECTION OF TEST SECTION

The data acquisition computers will interface with the MLS controller

A computerized data acquisition system has been designed to accompany the MLS. The data acquisition computers will interface with the MLS controller. The system will be state of the art, with numerous instrumentation channels and both low and high sampling rates. In addition to reading strain gauges in the pavement, several other measurements will be made automatically as well. On this first prototype, testing of the pavement section will require moving the machine off the test pavement. Surface profiling, falling weight deflectometer, and crack mapping will be performed.

The instrumentation and data acquisition package is being designed such that data can be transmitted from the site to the TxDOT home office. The office will also be able to access the operation of the MLS and transmit changes to the field. Much of the data will be reduced at the site to minimize analysis time.

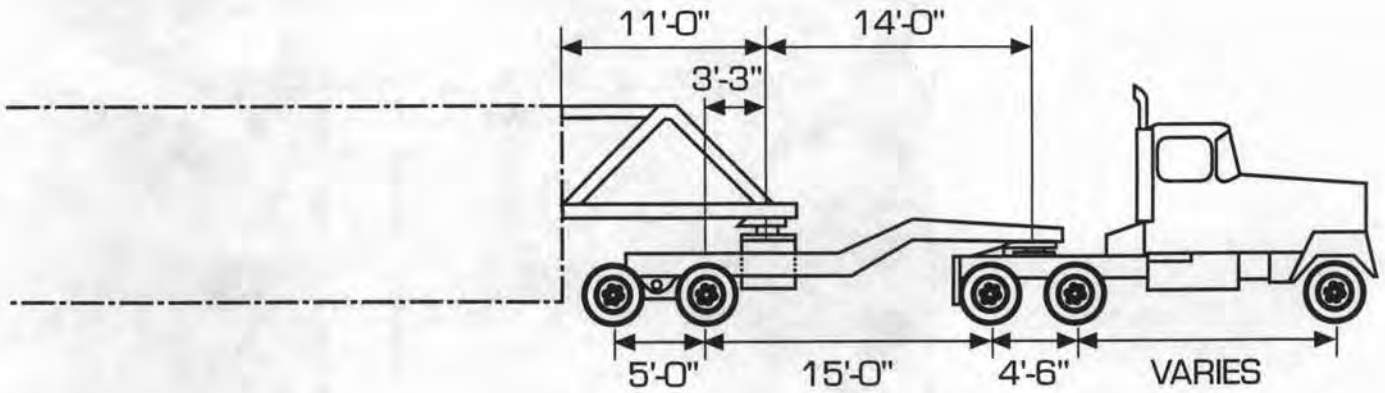

PROVISIONS FOR REAL TRAFFIC AND ENVIRONMENTAL SIMULATION

The utilization of real truck suspensions and axles make the TxMLS an excellent pavement evaluation tool

The TxMLS is capable of simulating actual traffic conditions to a degree unattainable by other linear load simulators. And such additional features as the utilization of real truck suspensions and axles make the TxMLS an excellent pavement evaluation tool.

As discussed earlier, environmental simulation can be achieved by utilizing the box-like structure of the TxMLS. By closing the sides, ends, and top, the designers have provided an environmental chamber. The uniqueness of this environmental chamber is its mobility (that is, it goes everywhere the TxMLS goes).

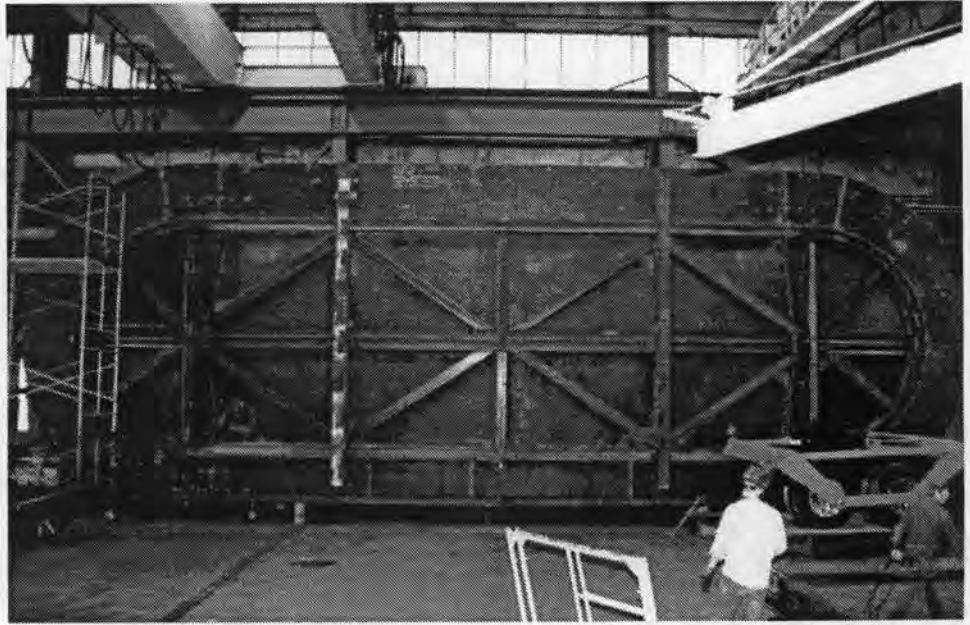

TxMLS JUSTIFICATION

The most significant benefit to be gained through application of the TxMLS is the high rate of real load application

Mobile load simulation has become an essential operation for progressive pavement agencies. Other mobile accelerated loading devices are in existence, and a comparison of the specifications of these devices is shown in *Table 1*. In *Tables 2a and 2b* the applicability of the respective machines for many pavement test variables is indicated.

The most significant benefit to be gained through application of the TxMLS is the high rate of real load application in contrast to other systems requiring overloading to accelerate the loading process. Combined with the vast amount of expertise available from the other two programs (the HVS and the ALF), the implementation of the Texas Mobile Load Simulator program should contribute tremendously to pavement engineering knowledge.

COMPARISON OF SPECIFICATIONS BETWEEN EXISTING SYSTEMS AND THE TxMLS

	ALF	HVS	TxMLS
Test loads/Axle (kip)			
Single Wheel	9.4 - 37.9 (41.8 - 168.6 kN)	4.5 - 45 (20.0 - 200.2 kN)	5 - 25 (22.2 - 111.2 kN)
Dual Wheels	9.4 - 37.9 (41.8 - 168.6 kN)	4.5 - 45 (20.0 - 200.2 kN)	8 - 43 (35.6 - 191.3 kN)
Test Wheel Size	11 x 22.5	14 x 20	11 x 24.5
Wheel Speed	12 mph (19.3 kph)	8 mph (12.9 kph)	20 mph (32.2 kph)
Axles / Hour	380	1,200	8,800
Trafficked Length	40 ft. (12.2 m)	32.8 ft. (10 .0 m)	36.5 ft. (11.1 m)
Lateral Displacement of Test Wheels	2.65 ft. (0.8 m)	4.9 ft. (1.5m)	2.0 ft. (0.6 m)
Other Lengths			
Testing	92.6 ft. (28.2 m)	74.15 ft. (22.6 m)	86.5 ft. (26.4 m)
Transportation	98.4 ft. (30.0 m)	74.15 ft. (22.6 m)	131 ft. (40 m)
Overall Width	13.8 ft. (4.2 m)	12.2 ft. (3.7 m)	12.6 ft. (3.8 m)
Overall Height			
Testing	22.0 ft. (6.7 m)	13.8 ft. (4.2 m)	22.5 ft. (6.9 m)
Transportation	14.4 ft. (4.4 m)	Unknown	13.25 ft. (4.0 m)
Total Mass	123 kips (62 tons) (547 kN)	125 kips (63 tons) (556 kN)	250 kips (125 tons) (1112 kN)

	ALF	HVS	TxMLS
Environmental Factors			
1. Surficial Water (Artificial)	par	par	YES
2. Sub-Surface Water	par	par	YES
3. Interaction of Artificial Environment with Accelerated Load	---	---	YES
Load Factors			
1. Varying Speed Wheel Loads	---	---	YES
2. Dynamic Wheel Loads	par	---	YES
3. Selected Wheels Configurations	YES	YES	YES
4. Multi-Axle Loads	---	---	YES
5. True Traffic Load with Accelerated Application Rate	---	---	YES
6. Specific Traffic Loads	par	par	YES
7. Selected Tire Types	YES	YES	YES
8. Selected Tire Pressures	YES	YES	YES
9. Lateral Load Distribution	YES	YES	YES
10. Axle Equivalency	par	par	YES
11. Suspension Types	par	---	YES
12. Overloads	YES	YES	YES
Material & Construction Factors			
1. Material Layer System	par	par	YES
2. Micro Material Structure	par	par	YES
3. Material Anisotropy	YES	YES	YES
4. Subgrade Compaction	par	par	YES
5. Various Subgrade Stiffness	par	par	YES
6. Various Subgrade Plastic Behavior	par	---	YES
7. Friction Between Layers	par	---	YES
8. Application of Rejuvenators	YES	YES	YES
9. New Materials/Mixtures	YES	YES	YES
10. D-Cracking	YES	YES	YES
11. Construction Variation	YES	YES	YES
12. Flexible Bases	par	par	YES
13. Lime Treated Bases	par	par	YES
14. Cement Treated Bases	par	par	YES
15. Recycled Asphalt	YES	YES	YES

Key:

YES = Applicable

par = partially applicable

--- = non-applicable

	<u>ALF</u>	<u>HVS</u>	<u>TxMLS</u>
Structural Factors			
1. Various Structural Systems	YES	YES	YES
2. Voids Beneath Concrete	YES	YES	YES
3. Effect of Shoulders	YES	YES	YES
4. Balanced Structural Composition	YES	YES	YES
Pavement Management and Performance (Real In-Service Pavements)			
1. Different Maintenance Strategies	YES	YES	YES
2. Different Rehabilitation Strategies	YES	YES	YES
3. Load Transfer in Joints	par	par	YES
4. Percent Steel	par	par	YES
5. Stripping of Asphalt	par	par	YES
6. Rutting	par	par	YES
7. Skid Resistance	par	---	YES
8. Wear of Aggregate	par	---	YES
9. Steel-Concrete Bond	par	par	par
10. Concrete Joint Behavior	par	par	YES
11. Fatigue Cracking	par	par	YES
12. Structural Condition of Pavement	par	par	YES
13. Surface Condition of Pavement	par	par	YES
14. Residual or Remaining Life	par	par	YES
15. Delamination	YES	YES	YES
16. Pavement Performance (PSI)	par	par	YES
Peripheral Pavement Engineering			
1. Durability of Traffic Monitoring Devices	---	---	YES
2. Durability of Road Markings	---	---	YES
3. Effects of Gradients	---	---	YES

Key:

YES = Applicable

par = partially applicable

--- = non-applicable



TxDOT

TEXAS DEPARTMENT OF TRANSPORTATION

*For more
detailed
information
or discussion
please contact
one of
the following:*

Mr. Roger Welsch, P.E.
Deputy Director
Field Operations
TxDOT, (FILE RGW)
125 E. 11th Street
Austin, Texas 78701-2483
(512)463-8672

Mr. Al Luedecke, P.E.
Division Head, Division of
Transportation Planning
TxDOT, (D-10 CH#1)
125 E. 11th Street
Austin, Texas 78701-2483
(512)465-7346

Mr. Michael Murphy, P.E.
Engineering Associate
TxDOT, (D-8PM CH#8)
125 E. 11th Street
Austin, Texas 78701-2483
(512)465-3686

Mr. Jeff Jackson, P.E.
Engineering Associate
TxDOT, (D-8PM CH#8)
125 E. 11th Street
Austin, Texas 78701-2483
(512)465-3684

Ms. Lisa Lukefahr
Engineering Assistant
TxDOT, (D-8PM CH#8)
125 E. 11th Street
Austin, Texas 78701-2483
(512)467-3996



CTR

CENTER FOR TRANSPORTATION RESEARCH

*For more
detailed
information
or discussion
please contact
one of
the following:*

Dr. B. Frank McCullough, P.E.
Director, CTR
The University of Texas at Austin
3208 Red River, Suite 200
Austin, Texas 78705-2650
(512)472-8875

Dr. Fred Hugo, P.E.
Research Fellow, CTR
The University of Texas at Austin
3208 Red River, Suite 200
Austin, Texas 78705-2650
(512)472-8875

Mr. Michael T. McNerney, P.E.
Research Associate, CTR
The University of Texas at Austin
3208 Red River, Suite 200
Austin, Texas 78705-2650
(512)472-8875

Mr. Michael Murphy, P.E.
Research Engineering Associate, CTR
The University of Texas at Austin
3208 Red River, Suite 200
Austin, Texas 78705-2650
(512)472-8875

Mr. Jeff Jackson, P.E.
Research Engineering Associate, CTR
The University of Texas at Austin
3208 Red River, Suite 200
Austin, Texas 78705-2650
(512)472-8875

PRODUCTION STAFF

Ray Donley III
Editor II

Michael E. Gray
Senior Computer Illustrator

James D. Speer
Computer Illustrator

CTR/graphics department
3208 Red River
Suite 200
Austin, Texas 78705
(512) 472-8875