

Technical Report Documentation Page

1. Report No. FHWA/TX-05/0-4485-2	2. Government Accession No.	3. Recipient's Catalog No.	
4. Title and Subtitle Design Guidelines for Multi-Tiered MSE Walls		5. Report Date August, 2005	
		6. Performing Organization Code	
7. Author(s) Stephen G. Wright		8. Performing Organization Report No. 0-4485-2	
9. Performing Organization Name and Address Center for Transportation Research The University of Texas at Austin 3208 Red River, Suite 200 Austin, TX 78705-2650		10. Work Unit No. (TRAIS)	
		11. Contract or Grant No. 0-4485	
12. Sponsoring Agency Name and Address Texas Department of Transportation Research and Technology Implementation Office P.O. Box 5080 Austin, TX 78763-5080		13. Type of Report and Period Covered Technical Report	
		14. Sponsoring Agency Code	
15. Supplementary Notes Project performed in cooperation with the Texas Department of Transportation and the Federal Highway Administration. Project Title: Design Methodology for Tiered MSE or Concrete Block Retaining Walls.			
16. Abstract <p>TxDOT is experiencing wider use of multi-tiered MSE and Concrete Block retaining walls. These walls often involve loads and geometric configurations that are different from the ones for which current FHWA and AASHTO design guidelines were developed. Accordingly, the current research project was undertaken. A review and detailed examination of the current guidelines and their application to multi-tiered walls has been completed and presented in an earlier project report. This review also included examination and additional analyses of a number of multi-tiered walls that were designed and built for TxDOT.</p> <p>This current report presents new guidelines for design of tiered MSE walls. For simple walls the design is facilitated by the use of design charts that were developed as part of this study and are presented in this report. For more complex walls, step-by-step procedures are presented. Use of the design procedures is demonstrated by application to several actual walls that were designed and constructed for TxDOT.</p>			
17. Key Words Limit equilibrium, Mechanically stabilized earth (MSE) walls, Retaining walls, Design, Geotechnical engineering.		18. Distribution Statement No restrictions. This document is available to the public through the National Technical Information Service, Springfield, Virginia 22161; www.ntis.gov	
19. Security Classif. (of report) Unclassified	20. Security Classif. (of this page) Unclassified	21. No. of pages 118	22. Price



Design Guidelines for Multi-Tiered MSE Walls

Stephen G. Wright

CTR Research Report:	0-4485-2
Report Date:	August 2005
Research Project:	0-4485
Research Project Title:	Design Methodology for Tiered MSE or Concrete Block Retaining Walls
Sponsoring Agency:	Texas Department of Transportation
Performing Agency:	Center for Transportation Research at The University of Texas at Austin

Center for Transportation Research
The University of Texas at Austin
3208 Red River
Austin, TX 78705

www.utexas.edu/research/ctr

Copyright (c) 2005
Center for Transportation Research
The University of Texas at Austin

All rights reserved
Printed in the United States of America

Disclaimers

Author's Disclaimer: The contents of this report reflect the views of the authors, who are responsible for the facts and the accuracy of the data presented herein. The contents do not necessarily reflect the official view or policies of the Federal Highway Administration or the Texas Department of Transportation (TxDOT). This report does not constitute a standard, specification, or regulation.

Patent Disclaimer: There was no invention or discovery conceived or first actually reduced to practice in the course of or under this contract, including any art, method, process, machine manufacture, design or composition of matter, or any new useful improvement thereof, or any variety of plant, which is or may be patentable under the patent laws of the United States of America or any foreign country.

Engineering Disclaimer

NOT INTENDED FOR CONSTRUCTION, BIDDING, OR PERMIT PURPOSES.

Project Engineer: Stephen G. Wright
Professional Engineer License State and Number: Texas No. 49007
P. E. Designation: Research Supervisor

Acknowledgments

The writer expresses appreciation to TxDOT for their support of this research study. He is particularly grateful for the vision, guidance, constructive criticism and continued encouragement of Mr. Mark McClelland and Mr. John Delphia of TxDOT. Mr. Marcus Galvin was also helpful in procuring design information for a number of the MSE walls that TxDOT has constructed.

The writer is also grateful to Mr. Wade Osborne and Mr. Lei Wang for their efforts in compiling and reviewing information for the MSE walls that TxDOT has constructed. Mr. Osborne and Wang also performed numerous analyses of MSE walls that eventually provided the background needed to develop the design procedures presented in this report.

Products

In this report, Product 1 and Product 3 are further developed. Product 3, Recommended Procedures for Design of Multi-Tiered MSE walls, can be found in Chapter 7. Several chapters of this report continue to develop Product 1, Simplified Design Procedures for Multi-Tiered Retaining Walls.

Table of Contents

Chapter 1 - Introduction.....	1
Introduction.....	1
Analyses of Typical Multi-Tiered Walls	3
Simple Design Procedures	3
Methodology.....	4
Chapter 2 - Estimation of Reinforcement Forces	5
Introduction.....	5
Calculation Procedure for Determining K.....	6
Comparison with FHWA Guidelines.....	10
Computation of Total Force Coefficients for Multi-Tiered Walls	14
Summary.....	24
Chapter 3 - Estimation of Reinforcement Lengths	29
Introduction.....	29
Required Reinforcement Lengths for Base of Wall System.....	29
Required Lengths of Reinforcement at Top of Wall System.....	40
Required Lengths of Reinforcement at Intermediate Levels	46
Multi-Tiered Walls with Nonuniform Tiers	48
Summary and Discussion.....	49
Chapter 4 - Design Examples	51
Introduction.....	51
Methodology - Definition of Factors of Safety	51
Example Multi-Tiered Wall Systems	52
Example 1 - Two-Tier Wall.....	53
Example 2 - Four-Tier Wall.....	58
Example 3 - Six-Tier Wall.....	61
Discussion.....	64
Chapter 5 - TxDOT Design Examples.....	67
Introduction.....	67
TxDOT Wall Number 1 - US 290, Austin.....	67
TxDOT Wall Number 2 - Socorro Bridge at US 375	72
Chapter 6 - Internal Stability and Pullout Resistance	77
Introduction.....	77
FHWA Guidelines for Two-Tier Walls	77
Elastic Stress Distributions	79
Comparison of Elastic and FHWA Suggested Stress Distributions	82
Discussion.....	84
Summary.....	85
Chapter 7 - Recommendations for Design.....	87
Introduction.....	87
Computation of Required Reinforcement Forces	87
Computation of Required Reinforcement Lengths.....	89
Global Stability Analyses - Assumptions for Analyses.....	95

Global Stability Analyses - Locating the Most Critical Slip Surface	98
Summary	102
Chapter 8 - Summary, Conclusions and Recommendations.....	103
Summary	103
Conclusions.....	103
Recommendations.....	104

List of Figures

Figure 1.1 Eight-tier wall system.....	2
Figure 1.2 Critical circle for eight-tier wall system.....	3
Figure 2.1 Single wall used to compute required reinforcement layers	7
Figure 2.2 Reinforcement layout used to compute required reinforcement forces.....	8
Figure 2.3 Required reinforcement forces for single wall with constant and linearly increasing reinforcement forces.....	9
Figure 2.4 Critical slip surfaces producing the maximum force for a single wall.....	10
Figure 2.5 Earth pressure coefficients for computing reinforcement forces for inextensible reinforcement according to FHWA guidelines.....	11
Figure 2.6 Variation in equivalent total force coefficient, K_T , with total wall height based on FHWA recommended earth pressure coefficients for inextensible reinforcement	12
Figure 2.7 Comparison of lines of constant force from limit equilibrium analyses with a constant reinforcement force and FHWA guidelines for inextensible reinforcement.....	13
Figure 2.8 Multi-tiered walls used to verify the dimensionless nature of total force coefficient, K_T	16
Figure 2.9 Variation in total force coefficient, K_T , with wall offset for a three-tiered wall.....	17
Figure 2.10 Comparison of ten-tiered wall system and continuous slope with the same total “offset” distance	18
Figure 2.11 Variation in total force coefficient, K_T , with “offset” for ten-tiered wall and continuous slope.....	19
Figure 2.12 Comparison of force coefficients from Schmertmann et al. with coefficients determined in this study	20
Figure 2.13 Variation in total force coefficient, K_T , with wall offset for 2, 3, 4, 6, and 10 tier wall systems	21
Figure 2.14 Variation in total force coefficient, K_T , with wall offset for 2 and 6 tier wall systems with friction angles (ϕ) of 24 and 34 degrees.....	23
Figure 2.15 Variation in normalized total force coefficient, K_T/K_A , with wall offset for 2 and 6 tier wall systems with friction angles (ϕ) of 24 and 34 degrees	24
Figure 2.16 Illustration of “offset ratio,” R_S , for multi-tiered wall systems.....	25
Figure 2.17 Variation in normalized total force coefficient, K_T/K_A , with offset ratio, R_S , for 2 and 6 tier wall systems with friction angles (ϕ) of 24 and 34 degrees	26
Figure 3.1 Critical slip circle through heel of “standard” reinforced wall section	30
Figure 3.2 Four walls to illustrate uniqueness of minimum factor of safety for slip surfaces through the “heel” of the reinforced soil mass — all walls have a minimum factor of safety of 1.54	30
Figure 3.3 Slip circle through “heel” of reinforced wall section	32
Figure 3.4 Example three-tiered wall system with 150 percent wall setbacks	32
Figure 3.5 Variation in developed friction angle with normalized length of bottom reinforcement for three-tiered wall with 150 percent setback	34

Figure 3.6 Variation in normalized length of bottom reinforcement with wall setback.....	35
Figure 3.7 Schematic for sliding of single and tiered wall systems with comparable base lengths	36
Figure 3.8 Continuous slope representation.....	37
Figure 3.9 Variation with wall offset in required values of normalized bottom length, L_B/H_{total} , for a 10 tier wall system and continuous slope.....	38
Figure 3.10 Comparison of required values of normalized base length, L_B/H_{total} , from Schmertmann et al. with values determined in this study	39
Figure 3.11 Variation with wall offset in required values of normalized bottom length, L_B/L_{total} , for reinforcement for 2, 3, 4, 6, and 10 tier wall systems and continuous slope	40
Figure 3.12 Example four-tiered wall used to illustrate calculation of required reinforcement base length	41
Figure 3.13 “Active” zone for extensible reinforcement according to FHWA (2001)	42
Figure 3.14 This Fig is a repeat of Fig 3.15 and is a placeholder until it can be replaced	43
Figure 3.15 Critical slip surfaces for linearly increasing and constant reinforcement forces — three tier wall system with 50 percent setback.....	43
Figure 3.16 Variation in normalized top lengths for reinforcement with wall offset for a three-tiered wall ssystem.....	44
Figure 3.17 Comparison of required top length for reinforcement from Schmertmann et al. and this study for continuous slopes	45
Figure 3.18 Variation with wall offset in required values of normalized top length, L_T/H_{total} , for reinforcement for 2, 3, 4, 6, and 10 tier wall systems and continuous slope.....	46
Figure 3.19 Determination of lengths of intermediate reinforcement for multi-tiered walls.....	47
Figure 3.20 Determination of reinforcement length requirements for example four-tiered wall	48
Figure 4.1 Example 1 — Two-tiered wall with 75 percent offset	52
Figure 4.2 Example 2 — Four-tiered wall with 50 percent offsets	53
Figure 4.3 Example 3 — Six-tiered wall with 100 percent offsets.....	53
Figure 4.4 Required reinforcement forces and lengths for two-tiered wall system with 75 percent offset — Friction angle = 34 degrees.....	55
Figure 4.5 Example 1 — Critical slip surface for two-tiered wall system with 75 percent offset — Reinforcement based on developed friction angle = 34 degrees	56
Figure 4.6 Example 1 — Critical slip surface for two-tiered wall system with 75 percent offset — Reinforcement forces based on developed friction angle = 24 degrees; reinforcement lengths based on active wedge for friction angle = 34 degrees	58
Figure 4.7 Example 1 — Required reinforcement forces and lengths for two-tiered wall system with 75 percent offset — Friction angle = 24 degrees	59

Figure 4.8 Example 2 — Required reinforcement forces and lengths for four-tiered wall system with 50 percent offset — Friction angle = 34 degrees	60
Figure 4.9 Example 2 — Required reinforcement forces and lengths for four-tiered wall system with 50 percent offset — Forces based on friction angle = 24 degrees; lengths based on friction angle = 34 degrees	61
Figure 4.10 Example 2 — Critical slip surface for four-tiered wall system with 50 percent offset — Reinforcement forces based on friction angle = 24 degrees; reinforcement lengths based on friction angle = 34 degrees.	61
Figure 4.11 Example 3 — Required reinforcement forces and lengths for six-tiered wall system with 100 percent offset — Friction angle = 34 degrees	62
Figure 4.12 Example 3 — Required reinforcement forces and lengths for six-tiered wall system with 100 percent offset — Forces based on friction angle = 24 degrees; lengths based on friction angle = 34 degrees.....	64
Figure 4.13 Example 3 — Critical slip surface for six-tiered wall system with 100 percent offset — Reinforcement forces based on friction angle = 24 degrees; reinforcement lengths based on friction angle = 34 degrees.....	64
Figure 5.1 Wall geometry for US 290 wall, Austin, Texas	68
Figure 5.2 Required reinforcement lengths for US 290 wall system — Friction angle = 34 degrees	70
Figure 5.3 Geometry of wall system located near Socorro Bridge at US 375.....	73
Figure 5.4 Required reinforcement lengths for wall system located near Socorro Bridge at US 375 — Friction angle = 34 degrees	74
Figure 6.1 FHWA criteria for vertical stress increase behind tiered walls with intermediate” horizontal offsets.....	78
Figure 6.2 Grey’s solution for the increase in vertical stress due to a uniform load over half the surface of a semi-infinite elastic half-space.....	79
Figure 6.3 Equivalent superimposed stresses used to represent the stresses produced by a vertical surcharge behind a “rigid” wall.....	80
Figure 6.4 Equivalent superimposed stresses used to represent the stresses produced by a vertical surcharge behind a “flexible” wall	81
Figure 6.5 Two-tier wall system used for vertical stress calculations	82
Figure 6.6 Comparison of increases in vertical stress behind a “rigid” and “flexible” wall calculated from classis solution at depths of 0.5, 1.0, 1.5, and 2.0 times the horizontal offset (D).....	83
Figure 6.7 Comparison of increases in vertical stress behind a wall calculated using FHWA guidelines for a two-tier wall and using the elastic solution for a “rigid” wall at depths of 0.5, 1.0, 1.5, and 2.0 times the horizontal offset (D).....	84
Figure 7.1 Assumed conditions for computation of required reinforcement forces for top two tiers of a 4 tier wall system.....	89
Figure 7.2 Assumed conditions for computation of required reinforcement forces for top three tiers of a 4 tier wall system.....	90

Figure 7.3 Skip surface passing through constrained point used to determine minimum required lengths of lower layers of reinforcement required to produce a developed friction angle of 20.6 degrees	91
Figure 7.4 Illustration of procedure for determining the minimum length for lower layers of reinforcement required to produce a developed friction angle of 20.6 degrees	92
Figure 7.5 Assumed conditions for computation of failure surface (“active” zone) at the top of the tiered wall system	93
Figure 7.6 Determination of minimum length (L_T) required for reinforcement at the top of a multi-tiered wall system.....	94
Figure 7.7 Determination of lengths of intermediate reinforcement for multi-tiered walls.....	95
Figure 7.8 Potential critical slip surfaces for “global” stability analyses	96
Figure 7.9 Slip surface exiting wall face at the same elevation as a layer of reinforcement.....	98
Figure 7.10 Trial slip surfaces for global stability analyses—through toe and heel of lower wall	99
Figure 7.11 Trial slip surfaces for global stability analyses—through all combinations of walls and toe of lower wall	100
Figure 7.12 Trial slip surfaces for global stability analyses—exiting at level of each layer of reinforcement.....	101
Figure 7.13 Trial slip surfaces for global stability analyses—external to wall and reinforced soil	102

List of Tables

Table 2.1 - Total required reinforcement forces computed from limit equilibrium analyses for a 10-foot high wall with 10 layers of reinforcement	27
Table 2.2 - Factors of safety on shear strength and corresponding developed friction angles required for reinforcement forces computed from limit equilibrium analyses to match those computed by FHWA guidelines (Reinforcement forces constant with depth)	27
Table 2.3 - Calculated values for total required force and coefficient KT for four, three-tiered walls with 50 percent setback	28
Table 4.1 - Summary of global stability analyses for four-tiered wall - Based on $\phi = 34$ degrees	60
Table 4.2 - Summary of global stability analyses for six-tiered wall - Based on $\phi = 34$ degrees	62
Table 5.1 - Summary of geometry for US 290 wall	68
Table 5.2 - Summary of required force calculations for US 290 wall - $\phi = 34$ degrees	69
Table 5.3 - Summary of required reinforcement forces for US 290 wall	72
Table 5.4 - Summary of reinforcement lengths for US 290 wall.....	72
Table 5.5 - Summary of geometry for wall near Socorro Bridge at US 375	73
Table 5.6 - Summary of required reinforcement forces for Socorro Bridge and US 375 wall.....	74
Table 5.7 - Summary of required reinforcement forces for Socorro Bridge and US 375 wall.....	75
Table 5.8 - Summary of reinforcement lengths for Socorro Bridge and US 375 walls	76

Chapter 1 - Introduction

Introduction

Mechanically stabilized earth (MSE) walls have been successfully used in the United States for over thirty years and even longer overseas. As use has grown and been accompanied by success, the nature of MSE walls has evolved. While many of the initial walls consisted of only a single tier, it is not uncommon today to see walls being built with two, three, and even more tiers. While the design methodology for single-tiered walls is well established, design procedures for multi-tiered walls are much more limited. Design procedures based on an assessment of the “global” or overall stability are particularly not well defined.

Current FHWA guidelines (Elias et al., 2001) only directly address directly multi-tiered (superimposed) walls with two tiers. For such walls, the guidelines suggest that the individual walls in the tiered system can be treated as separate, independent walls when the offset distance, D , exceeds the following:

$$D = H_2 \tan(90 - \phi_r) \quad (\text{Eq. 1.1})$$

where H_2 is the height of the lower of the two tiers and ϕ_r is the friction angle for the reinforced soil backfill. Consider as an example the two-tiered wall system shown in Figure 1.1. Each wall is 10 feet high and reinforcement in each tier is 7 feet long. This length corresponds to 0.7 times the wall height, which is the typical length of reinforcement for a single-tiered wall. Each wall is offset by a distance of 16 feet from the wall below. According to current FHWA guidelines, a typical minimum friction angle for the reinforced soil is 34 degrees. Thus, the offset distance given by Equation 1.1 is as follows:

$$D = (10) \tan(90^\circ - 34^\circ) = 14.8 \text{ feet} \quad (\text{Eq. 1.2})$$

The offset distance (16 feet) of the walls shown in Figure 1.1 exceeds the distance of 14.8 feet. Thus, according to FHWA guidelines, the two-tiered wall system can be treated as individual walls.

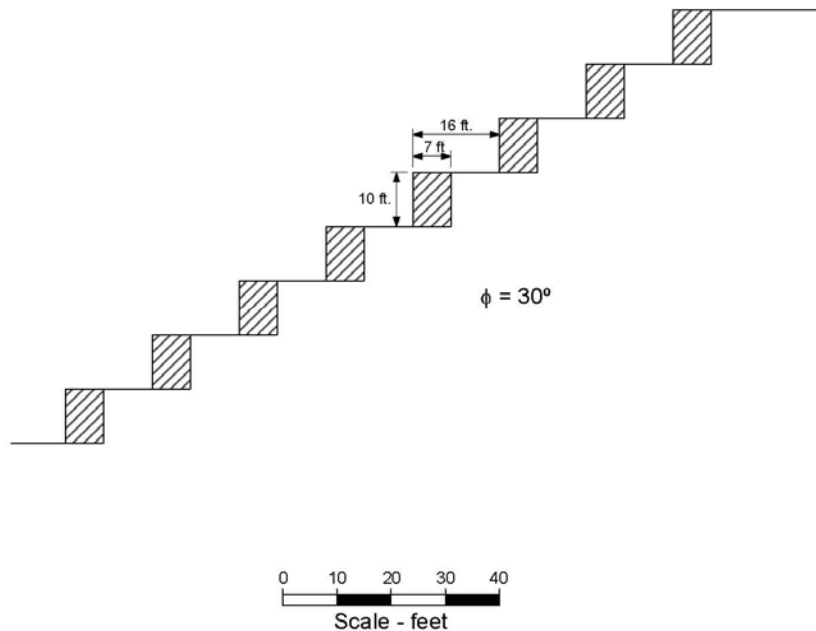

Figure 1.1 Eight-tier wall system

Next, consider extension of the two-tiered wall system shown in Figure 1.1 to an eight-tiered wall system like the one illustrated in Figure 1.2. The walls are again each 10 feet high and the offset exceeds the distance given by Equation 1.2 where the walls can be treated as individual walls. The overall (global) stability of the eight-tier wall system shown in Figure 1.2 was evaluated by a series of conventional slope stability analyses. Sufficient reinforcement was assumed to prevent any slip surface from passing through the reinforced soil mass. The soil behind the walls as well as the underlying foundation soil was assumed to have a friction angle of 30 degrees, a value that current FHWA guidelines suggest as a typical lower limit. All soil was assumed to be free-draining and free of water. Computations were performed using circular slip surfaces and the Simplified Bishop procedure of slope stability analysis. The critical slip surface (lowest factor of safety) is shown in Figure 1.3. The corresponding minimum factor of safety is approximately 1.11. FHWA guidelines currently suggest a factor of safety of 1.5 should be provided for overall stability of multi-tiered walls. Clearly the wall system shown in Figure 1.2 does not meet this requirement, even though the walls would qualify for treatment as single-tiered walls by FHWA guidelines for two-tiered walls and meet the requirements for stability of single-tiered walls. Although the FHWA criteria for two-tiered wall systems may be appropriate for such two-tiered wall systems, they clearly are not applicable to tiered wall systems with much larger numbers of tiers.

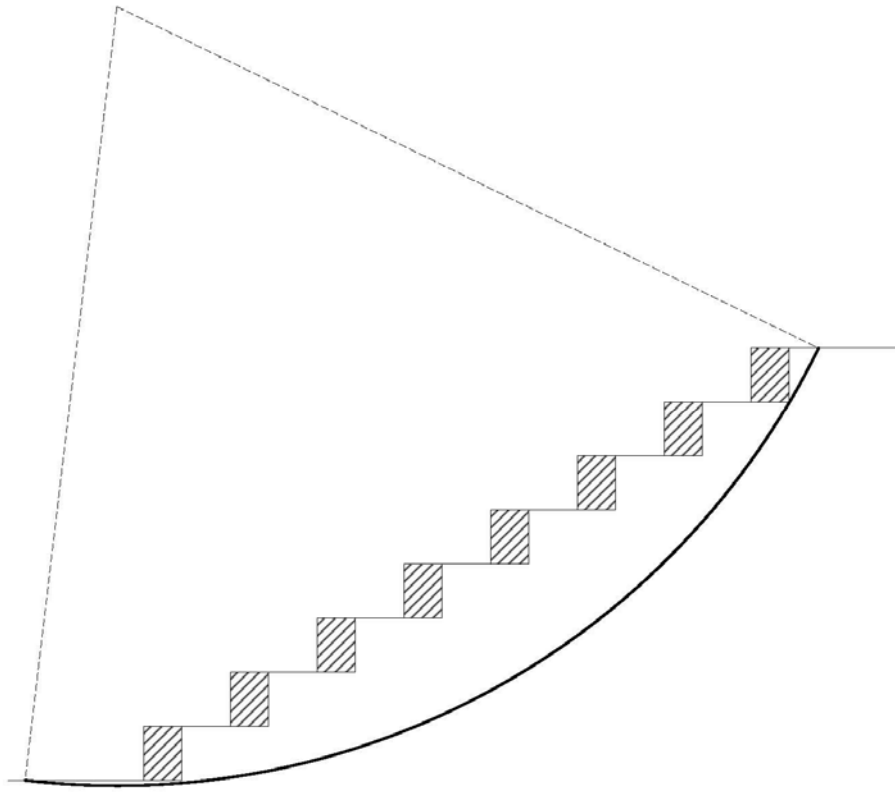

Figure 1.2 Critical circle for eight-tier wall system

Analyses of Typical Multi-Tiered Walls

To gain insight into issues involved with multi-tiered walls and the application of current FHWA and AASHTO guidelines, analyses were undertaken of a number of single and multi-tiered walls that were designed and built for TxDOT. These analyses served to identify a number of important issues regarding the design of walls by current guidelines. In several cases involving multi-tiered walls, either no global stability analysis was performed or results were not reported. Accordingly, particular emphasis was placed on the evaluation of global stability. For each wall, global stability analyses were performed using commercially available slope stability software. Based on these analyses it was possible to make recommendations for use of such slope stability analysis software to evaluate multi-tiered walls and in particular their global stability. Results of the analyses and recommendations are presented by Osborne (2004) and Wang (2005).

Simple Design Procedures

While analyses like those performed by Osborne (2004) and Wang (2004) are useful for evaluating the stability of any MSE wall design and are essential for evaluation of more complex wall systems, they are sometimes too complex and time-consuming for

preliminary design, especially for simple wall systems. Furthermore, it is helpful to have simple procedures that can be used for preliminary checking and evaluation of more complex wall systems. Usually the more complex procedures are only used once a general design, e.g., wall geometry and general reinforcement capacities, have been established.

In conjunction with the more complex analyses performed by Wang and Osborne for this study, simpler procedures for design have been explored and evaluated. In developing the simpler procedures, an effort has been made to develop procedures that are consistent with both the current design procedures for single-tiered walls and the design procedures for reinforced slopes. As the number of tiers in a wall system increases, the wall system is believed to approach a behavior more like that of a slope. For example the eight-tier wall system shown in Figure 1.2 appears to behave as much like a reinforced slope as a system of tiered walls.

Methodology

In the following chapters, a methodology for design of multi-tiered wall systems is presented. In Chapter 2 procedures for estimating the reinforcement forces required for stability of the wall system are presented. Procedures for estimating the required length of reinforcement once the forces are established are presented in Chapter 3. The procedures presented in Chapters 2 and 3 provide the essential elements of design of multi-tiered walls, particularly with respect to overall or global stability. In Chapter 4, the procedures developed in Chapters 2 and 3 are applied to the design of three different hypothetical wall systems. Although the procedures presented in Chapters 2 and 3 are developed primarily for design of wall systems with walls all of the same height and with a constant offset distance, the general methodology can be applied to the design of more complex systems with varying wall heights and offsets. In Chapter 5, the basic design methodology is applied to determine the reinforcement requirement for two multi-tiered walls that were designed and have been built for TxDOT. The reinforcement requirements for the two walls are then compared with those determined by the original wall designers. Considerations regarding internal stability and pullout resistance of the reinforcement are addressed in Chapter 6. General recommendations for design are presented in Chapter 7. A brief summary of this work and recommendations for additional work are presented in Chapter 8.

Chapter 2 - Estimation of Reinforcement Forces

Introduction

Current FHWA design guidelines (Elias et al., 2001) and AASHTO design specifications (AASHTO, 1998, 2003) for single-tiered MSE walls involve calculating the maximum force in each level of reinforcement produced by horizontal earth pressures. For the most part, the earth pressures and forces are calculated assuming that the shear strength of the soil is fully developed, i.e., the earth pressures are assumed to be “active” earth pressures. This is consistent with the observation that for many conventional concrete gravity retaining walls, only small amounts of movement are required to fully develop the strength of the soil and the corresponding active earth pressures. An exception may exist for MSE walls with very stiff reinforcement, particularly at shallow depths in walls with metallic reinforcement. This is suggested in the FHWA guidelines by the use of higher than active earth pressure coefficients for the upper portion (less than 6 m depth) of MSEW walls with “inextensible” reinforcement.

For simple walls constructed of cohesionless soil ($c = 0$) and with a horizontal back-slope and no surcharge, the horizontal earth pressures are expressed as,

$$\sigma_h = K\gamma z \quad (\text{Eq. 2.1})$$

where K is the earth pressure coefficient, γ is the total unit weight of soil, and z is the depth below the ground surface. For a wall of height, H , the total horizontal force, T_{total} , that must be resisted by reinforcement is obtained by integrating Eq. 2.1 as,

$$T_{\text{total}} = \int_0^H K\gamma z \quad (\text{Eq. 2.2})$$

For a constant earth pressure coefficient, K , the total force becomes after integration,

$$T_{\text{total}} = \frac{1}{2} K\gamma H^2 \quad (\text{Eq. 2.3})$$

For multi-tiered walls, the horizontal stress, σ_h , probably varies both horizontally and vertically. Thus, the calculation of the total force, T_{total} , becomes more complex. However, it is still convenient to express the total reinforcement force required using an equation like Eq. 2.3. The force, T_{total} , then represents the maximum force required in the reinforcement with the shear strength of the soil fully developed. The force and, thus, the coefficient, K , will depend on the configuration of the multi-tiered wall system as well as to some extent on how the reinforcement forces (horizontal stresses) are distributed vertically.

This chapter focuses on the appropriate earth pressure coefficient, K , to be used in calculating the total required reinforcement force. Once the coefficient K is calculated, the total force is easily computed from Eq. 2.3.

Calculation Procedure for Determining K

The reinforcement force required for equilibrium can be calculated using the same limit equilibrium procedures of slices that are used to compute factors of safety for reinforced walls and slopes. For this study, the UTEXAS4 software was used for this purpose. To calculate the reinforcement force required for equilibrium, a set of reinforcement forces was assumed and the factor of safety with respect to shear strength was calculated. This process was repeated until the calculated factor of safety applied to shear strength was unity (1.0). The corresponding reinforcement force then represented the reinforcement force required for equilibrium when the shear strength is fully developed. This is comparable to what is done in the present FHWA design procedure where active earth pressures are used. That is, the reinforcement force that is calculated is the one that produces equilibrium with the soil shear strength fully developed.

Once the required reinforcement force was calculated according to the procedure just described, the corresponding total force coefficient, K_T , was calculated from Eq. 2.3, written as,

$$K_T = \frac{2 T_{\text{total}}}{\gamma H^2} \quad (\text{Eq. 2.4})$$

where T_{total} is the required reinforcement force determined from the limit equilibrium analysis and H is the wall height. The notation, K_T , is used to describe the coefficient to distinguish it from the earth pressure coefficient, K , in Eq. 2.1. If the earth pressure coefficient, K , is constant, the two coefficients, K and K_T , are the same, but if K varies with depth, K and K_T are different. The coefficient, K_T , depends on the geometry of the wall system (number of tiers, offset of individual tiers, etc.) and the soil shear strength. The coefficient, K_T , also depends on the reinforcement layout and, in particular, on how the reinforcement forces are distributed vertically over the height of the wall or wall tiers.

To illustrate and examine how the distribution of reinforcement forces affects the total force required for equilibrium, a series of analyses was performed for the single-tiered wall shown in Figure 2.1¹. Computations were performed using the Simplified Bishop procedure of slices. The Simplified Bishop procedure assumes circular slip surfaces and for the present analyses, all circles were assumed to pass through the toe of the wall. For each set of reinforcement forces described below, the “critical” slip surface corresponding to the minimum factor of safety was located.

¹ Reinforcement is not shown in this figure, but is shown in Figure 2.2.

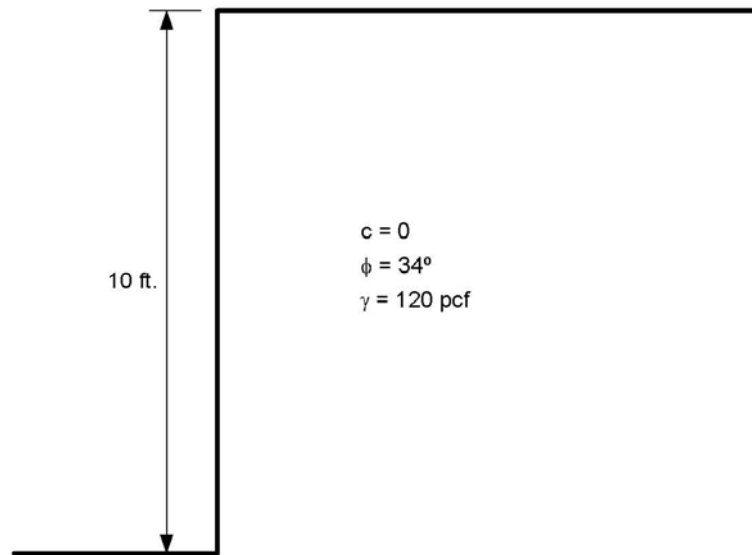

Figure 2.1 Single wall used to compute required reinforcement layers

The wall was assumed to be reinforced by 10 layers of reinforcement, equally spaced as shown in Figure 2.2. The reinforcement was assumed to be very long so that each slip surface passed through all layers of reinforcement, i.e., the force in all layers contributed to equilibrium. Two different patterns of forces were assumed. For the first pattern, the forces were assumed to increase linearly from the top to the bottom of the wall. For the second pattern, the forces were assumed to be constant, i.e., each layer of reinforcement had the same force. The magnitude of the forces in each layer of reinforcement was varied as described earlier until the factor of safety for soil shear strength was 1.0.

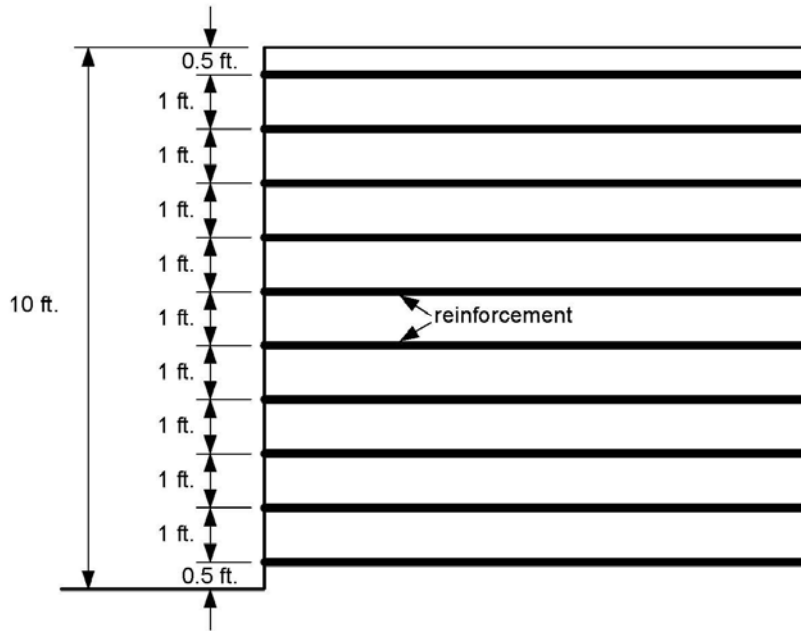
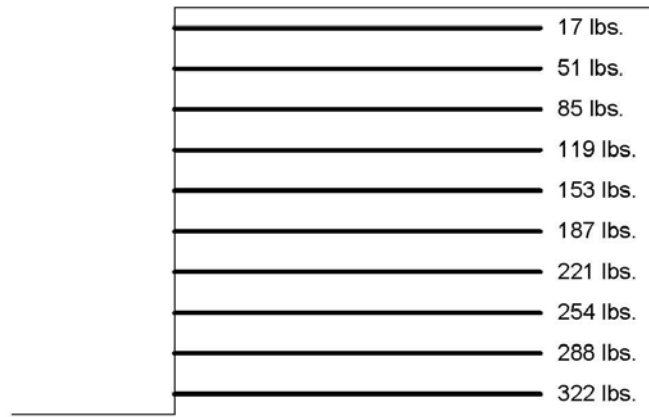

Figure 2.2 Reinforcement layout used to compute required reinforcement forces

The reinforcement forces that produce a factor of safety of one are shown in Figure 2.3 for the linearly increasing and constant distributions of forces assumed. The total required forces are summarized in Table 2.1. The corresponding force coefficients, K_T , calculated using Eq. 2.4 are also shown in Table 2.1. The value of the coefficient for linearly increasing forces is 0.283. This value is identical to the active Rankine earth pressure coefficient, K_A , which is given by,

$$K_A = \tan^2 \left(45^\circ - \frac{\phi}{2} \right) = \tan^2 \left(45^\circ - \frac{34^\circ}{2} \right) = 0.283 \quad (\text{Eq. 2.5})$$

The value of the total force coefficient for constant forces is 0.355, which is approximately 25 percent higher than the value for linearly increasing forces and active Rankine earth pressures. The higher coefficient for constant forces can be explained in part by the shorter distance between the total resultant reinforcement force and the center of a circular slip surface compared to linearly increasing forces. This results in a shorter moment arm for the resisting moment produced by the reinforcement and, thus, a higher force (higher force coefficient) is required to achieve equilibrium.



(a) Linearly increasing force

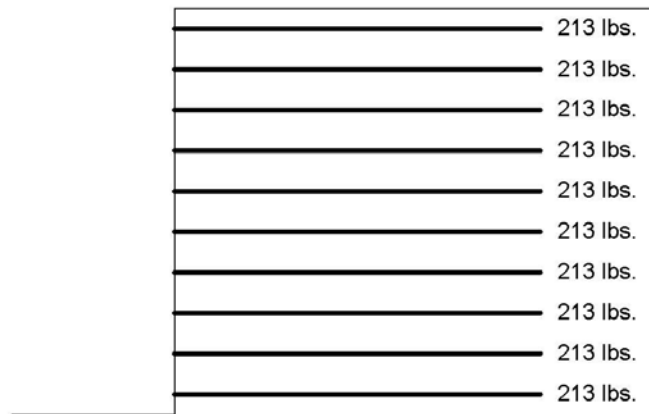

(b) Constant force

Figure 2.3 Required reinforcement forces for single wall with constant and linearly increasing reinforcement forces

The vertical distribution of forces in the reinforcement also affects the location of the critical slip surface for the maximum forces. The critical slip surface forces that increase linearly with depth are shown in Figure 2.4a. Although the slip surface was determined using circular slip surfaces, the radius of the critical slip surface is very large, causing the slip surface to degenerate to essentially a planar surface. The “circular” slip surface shown in Figure 2.4a is inclined at approximately 62 degrees from the horizontal, which is the same inclination as the critical slip plane for active Rankine earth pressures: The critical slip plane for active earth pressures is inclined at an angle of $45 + \phi/2$ from the horizontal, which is 62 degrees for a friction angle of 34 degrees.

The critical slip surface for reinforcement forces that are constant with depth is shown in Figure 2.4b. This slip surface has a more distinct circular shape and is essentially vertical at the point where it intersects the top of the wall backfill, i.e., the center of the critical circle is at the same elevation as the top of the wall.

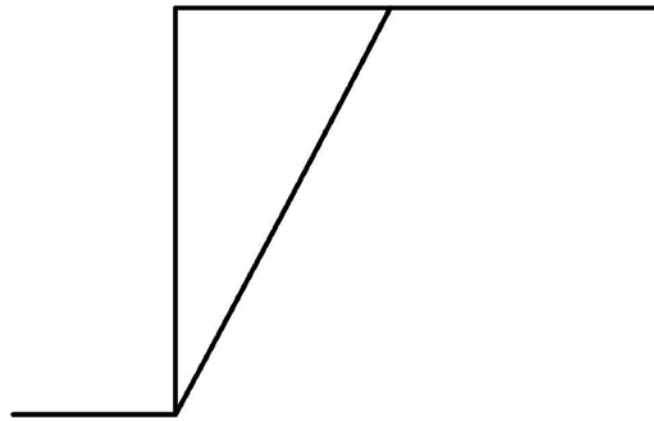

(a) Linearly increasing force

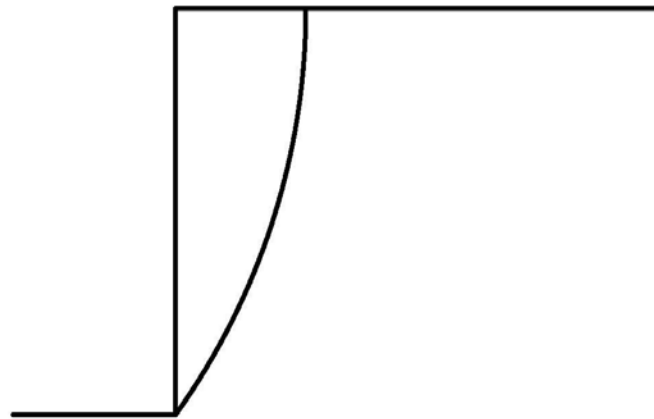

(b) Constant force

Figure 2.4 Critical slip surfaces producing the maximum force for a single wall

Comparison with FHWA Guidelines

FHWA guidelines (Elias et al., 2001) stipulate different criteria for calculating reinforcement forces for extensible and inextensible reinforcement. For extensible reinforcement, such as geogrids, the guidelines stipulate that the active Rankine earth pressure coefficient can be used to calculate the reinforcement forces. They also stipulate that the line (plane) of maximum reinforcement forces is the active Rankine slip plane. Thus, the force coefficient and critical slip surface presented in the previous section based on limit equilibrium analyses with reinforcement forces increasing linearly with depth are identical to those presented in the FHWA guidelines for extensible reinforcement.

For inextensible reinforcement, the FHWA-recommended procedure employs an earth pressure coefficient, K , that depends on the type of inextensible reinforcement and varies with depth as shown in Figure 2.5. The coefficients, K , shown in Figure 2.5 correspond to the earth pressure coefficient used to compute horizontal stresses in Eq.

2.1. To compute the corresponding total force coefficient, K_T , the stresses must first be integrated over the height of the wall to compute the total force, T_{total} , and then Eq. 2.4 can be used to compute the equivalent total force coefficient, K_T . Thus,

$$K_T = \frac{2 \int_0^H K \gamma z}{\gamma H^2} \quad (\text{Eq. 2.6})$$

The values for K inside the integral in Eq. 2.6 correspond to the values shown in Figure 2.5. Equation 2.6 then leads to the values for the total force coefficients, K_T , shown in Figure 2.6. The total force coefficients are largest for small wall heights with maximum values of 0.71 and 0.48 for metal grids (including bar mats and welded wire grids) and metal strips, respectively. The total force coefficients decrease as the wall height increases, reaching a value of 0.35–0.36 for wall heights of 15 meters. The values for these larger wall heights are very close to the value (0.355) that was obtained from the limit equilibrium analyses assuming a constant reinforcement force over the wall height. However, the values for smaller wall heights are much greater than those determined from limit equilibrium analyses. The reason for the larger values of the total force coefficient for inextensible reinforcement and smaller wall heights is probably due in part to the inextensible nature of the reinforcement and the full shear strength of the soil not being fully developed. However, there may be other factors that contribute as well.

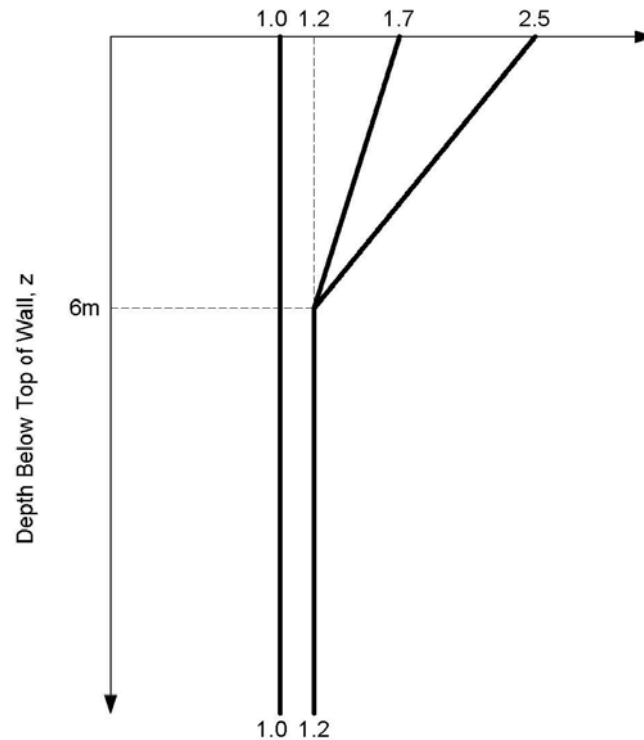

Figure 2.5 Earth pressure coefficients for computing reinforcement forces for inextensible reinforcement according to FHWA guidelines

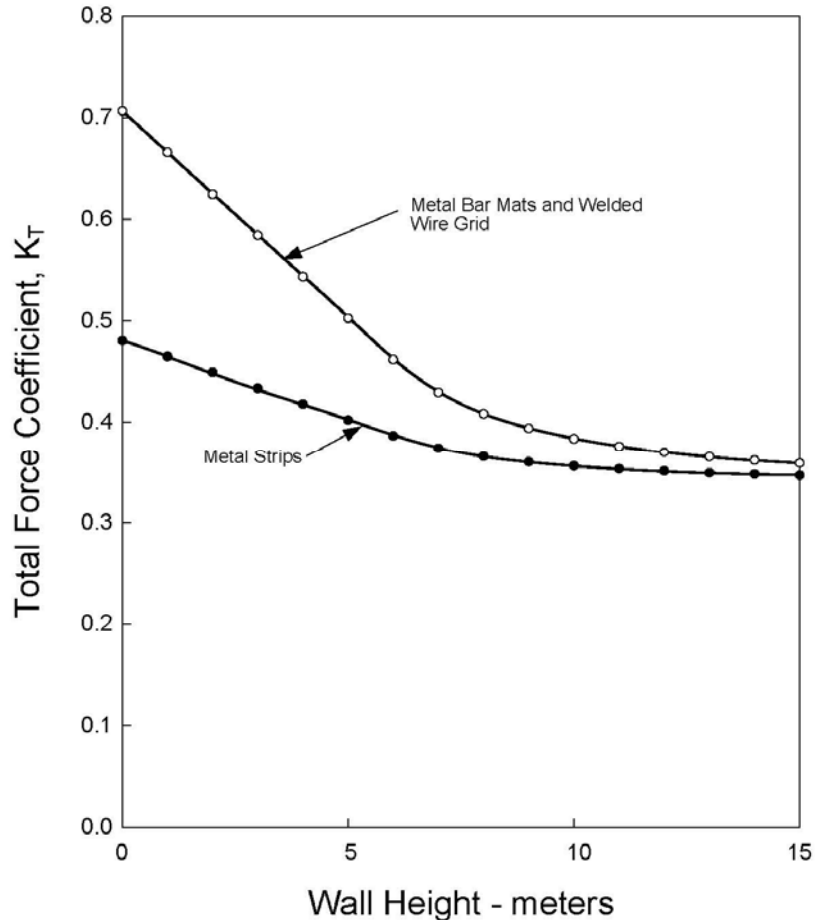

Figure 2.6 Variation in equivalent total force coefficient, K_T , with total wall height based on FHWA recommended earth pressure coefficients for inextensible reinforcement

For inextensible reinforcement, FHWA guidelines suggest that the line of maximum reinforcement force is like the one shown in Figure 2.7. Also shown in this figure is the critical slip surface from the limit equilibrium analyses that were performed assuming a constant reinforcement force. The two surfaces shown in Figure 2.7 corresponding to the maximum reinforcement force are very similar. This similarity exists independently of wall height.

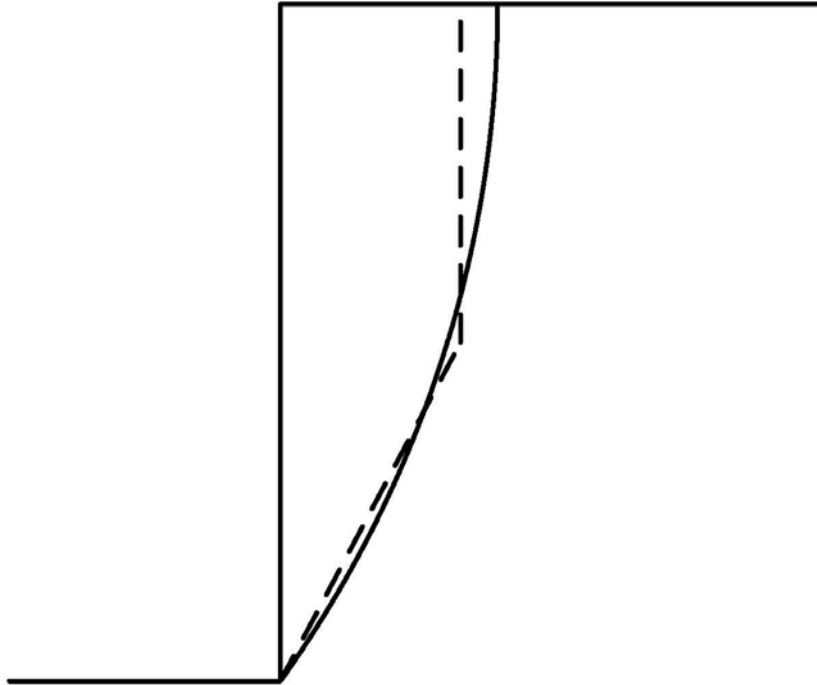

Figure 2.7 Comparison of lines of constant force from limit equilibrium analyses with a constant reinforcement force and FHWA guidelines for inextensible reinforcement

There is close similarity between the total forces determined using the FHWA guidelines for inextensible reinforcement for higher walls and limit equilibrium analyses with a constant reinforcement force. There is also close similarity between the lines of maximum force (Figure 2.7). This close similarity suggests that limit equilibrium analyses with an assumed constant reinforcement force over the height of the wall can be used to compute the required reinforcement force for walls with inextensible reinforcement, especially for higher walls.

For low walls, the FHWA guidelines produce a total force that is higher than the force calculated from limit equilibrium analyses assuming either linearly increasing or constant reinforcement forces over the height of the wall. This suggests that the shear strength of the soil may not be fully developed due to the relatively high stiffness of the reinforcement. However, it may still be appropriate to calculate the reinforcement force from limit equilibrium analyses, provided that only a fraction, rather than all, of the soil shear strength is assumed to be developed. To illustrate what fraction of the shear strength may actually be developed, an additional series of analyses similar to those described earlier was performed. However, instead of assuming that the shear strength was fully developed, as was done earlier, only a fraction of the shear strength was assumed to be developed, i.e., the factor of safety applied to shear strength was greater than unity (1.0). Various values were assumed for the factor of safety for shear strength and the required reinforcement forces were computed. This was done until the required reinforcement force was the same as the required force based on the FHWA guidelines for inextensible reinforcement. The factor of safety applied to shear strength (amount of shear strength developed) depended on the assumed height of the wall as well as on the type of inextensible reinforcement, i.e., the same factors that influence the coefficients

shown in Figures 2.5 and 2.6. The computed factors of safety are summarized in Table 2.2 along with the corresponding developed friction angles. The developed friction angles are based on the assumed friction angle of 34 degrees for the soil. The factors of safety range from about 2.25 to 1.0. This indicates that for low walls and very inextensible reinforcement, less than half the shear strength may be developed.

Based on the above analyses for walls constructed of inextensible reinforcement, it appears that the stresses and required forces can be calculated in either of two ways: First, they can be calculated according to FHWA guidelines using the increased earth pressure coefficients shown in Figure 2.5. Alternatively, the forces can be calculated from limit equilibrium analyses or active earth pressure theories using a reduced friction angle based on the factors of safety shown in Table 2.2. The second approach of using a reduced friction angle may be especially useful for analyses of multi-tiered walls where empirical correlations for earth pressure coefficients like those shown in Figure 2.5 are not available.

Computation of Total Force Coefficients for Multi-Tiered Walls

To extend results like those presented in the previous sections to multi-tiered walls, several series of limit equilibrium analyses were performed. Various wall configurations were assumed and the required reinforcement forces were calculated. For all calculations, the reinforcement force was assumed to be constant over the height of the wall. Very little is known about the actual distribution of force among the various layers of reinforcement for multi-tiered walls. As shown earlier, the assumption of a constant force results in a higher required force than when the reinforcement forces are assumed to increase linearly. The actual forces are probably distributed in a pattern somewhere between these two extremes (constant and linearly increasing). Thus, the assumption of a constant force appears reasonable and is probably conservative for at least some cases.

For multi-tiered walls, the total required reinforcement force, T_{total} , is expressed in terms of the total height of all tiers in the wall system by an equation of the form,

$$T_{total} = \frac{1}{2} K \gamma H_{total}^2 \quad (\text{Eq. 2.7})$$

where H_{total} is the total height of all walls in the system. The total force coefficient was calculated from the total force computed from the limit equilibrium stability analyses using the following relationship:

$$K_T = \frac{2 T_{total}}{\gamma H_{total}^2} \quad (\text{Eq. 2.8})$$

Assumed Wall Conditions

Each wall in the multi-tiered wall system was assumed to be 10 feet high, although due to the dimensionless nature of the computed total force coefficient, K_T , the values for K_T do not depend on the individual wall height. The reinforced soil was assumed to have a total unit weight of 125 pcf. The assumed unit weight also had no effect on the computed value of K_T . The reinforced soil was assumed to be cohesionless and have a

friction angle of 34 degrees, which is a value typically assumed as a lower-bound strength for reinforced soil for design of MSE walls (Elias et al., 2001).

Each tier of the wall system was assumed to have ten layers of reinforcement, equally spaced in the vertical direction. The reinforcement was assumed to be long enough that any slip surface intersected all lines of reinforcement. The force in each layer of reinforcement was assumed to be the same and the force was varied until the factor of safety for shear strength was unity (1.0). This is the same procedure used previously to calculate K_T for the single-tier walls.

For a given number of tiers in the tiered wall system, the horizontal separation distance between the faces of adjacent walls was varied. This distance is referred to as the “offset distance” or simply the “offset”. The offset distance was expressed as a percentage of the individual wall height. For example, a multi-tiered wall system with 10-foot high walls separated horizontally by 5 foot offsets is considered to have a 50 percent offset. A constant offset was assumed for all walls in a given multi-tiered wall system.

The total force coefficient, K_T , for multi-tiered walls with a given number of tiers is a unique function of the percentage of offset between individual walls. To illustrate this function, computations were performed for the four multi-tier wall systems shown schematically in Figure 2.8. In addition to varying the actual wall heights and offset distances, the unit weight of soil was also varied. However, all four wall systems had the same *percentage* offset. The total required reinforcement forces and corresponding coefficients, K_T , calculated for the four wall systems are summarized in Table 2.3. It can be seen that while the wall heights, offset distances and unit weight of soil were varied, the total force coefficient, K_T , did not change, thus illustrating the uniqueness of the relationship between K_T and the percentage of wall offset.

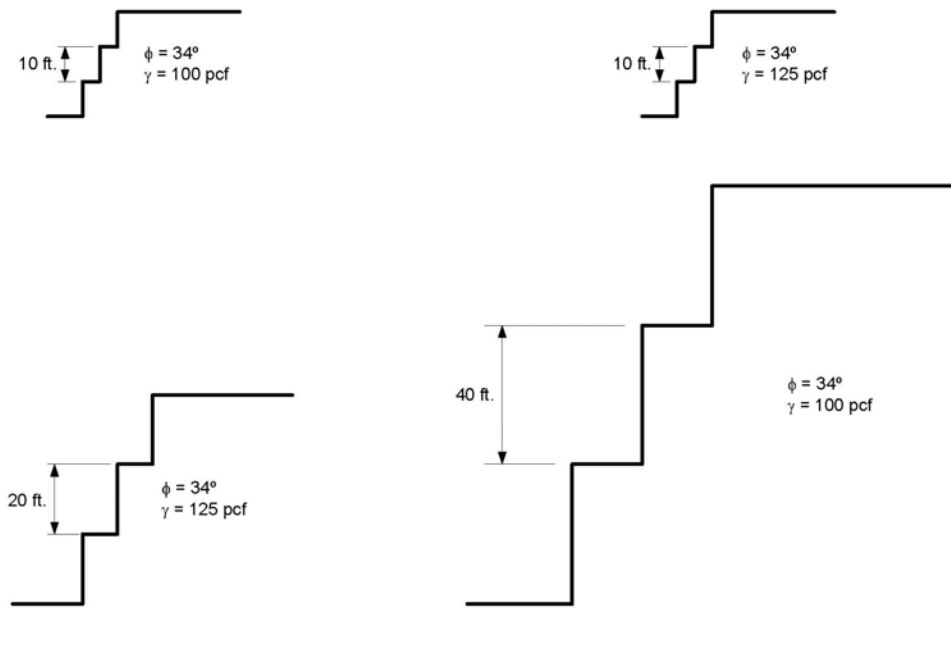

Figure 2.8 Multi-tiered walls used to verify the dimensionless nature of total force coefficient, K_T

Variation in K_T with Wall Setback

The variation in K_T with percent wall offset is shown in Figure 2.9 for a three-tier wall system. The value of K_T for zero offset is identical to the value of 0.355 for a single-wall system. As the offset increases, the value of K_T decreases. At some point (offset distance), the adjacent walls are separated a sufficient distance that the walls behave as independent walls and the total required force is simply the summation of the total required force for the individual walls acting independently as isolated, single walls. At this point the total force coefficient is given by,

$$K_T = \frac{K_{T\text{-single}}}{n^2} \quad (\text{Eq. 2.9})$$

where $K_{T\text{-single}}$ is the value of K_T for a single wall and “n” is the number of wall tiers. Thus, with $K_{T\text{-single}} = 0.355$,

$$K_T = \frac{0.355}{n^2} \quad (\text{Eq. 2.10})$$

and for the three-tiered wall system represented in Figure 2.9,

$$K_T = \frac{0.355}{3^2} = 0.039 \quad (\text{Eq. 2.11})$$

Once the offset for a three-tiered wall system increases to the point where the value of K_T reaches 0.039, the walls behave as isolated, individual walls. This behavior is reflected in Figure 2.9, where the curve is terminated at an offset of approximately 127 percent of the

individual wall height. In other words, for a three-tiered wall system with 10 foot high walls, the walls act as individual walls in terms of the required reinforcement forces at an offset of approximately 12.7 feet (= 127% x 10 ft.).

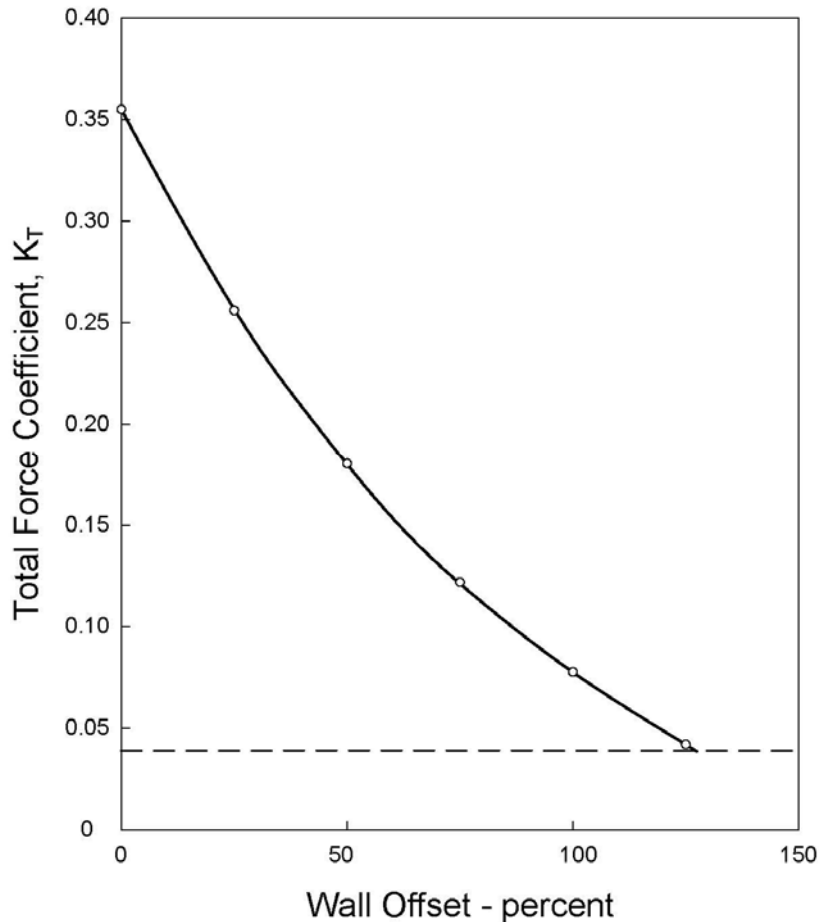

Figure 2.9 Variation in total force coefficient, K_T , with wall offset for a three-tiered wall

Similarities Between Multi-Tiered Walls and Slopes

As the number of tiers in a wall system becomes large, it seems reasonable to expect that there would be similarities between a multi-tiered wall and a continuous slope. For example, the ten-tiered wall system and continuous slope shown in Figure 2.10 appear to be very similar. A similar situation was shown for an eight-tier wall system in Chapter 1 where the multi-tiered wall system acted like a partially reinforced slope. To illustrate further the similarity between multi-tiered walls and continuous slopes, the total force coefficients were computed and compared for a continuous slope and a ten-tiered wall system. The offset distances were varied and the total force coefficients were computed for each offset distance. For the slope, the total “offset” distance was considered to be

the horizontal distance between the top and bottom of the slope face. Thus, the offset distance for the slope, expressed as a percentage is given by,

$$\text{Offset (percent)} = \frac{100\%}{\tan(\beta)} \quad (\text{Eq. 2.12})$$

where β is the slope angle measured from the horizontal plane. The offset distance for the continuous slope was varied by simply changing the slope angle, β .

The total force coefficient (K_T) computed for both the wall system and continuous slope are plotted versus offset distances in Figure 2.11. It can be seen that the values are very similar for both the ten-tier wall system and the continuous slope. This close similarity indicates that a continuously reinforced slope represents an “upper bound”² for multi-tiered wall systems. One should expect that the requirements for a multi-tiered wall system with numerous tiers and a continuous slope might be similar in terms of the strength of reinforcement required to achieve a certain level of safety, and the results presented in Figure 2.11 confirm this.

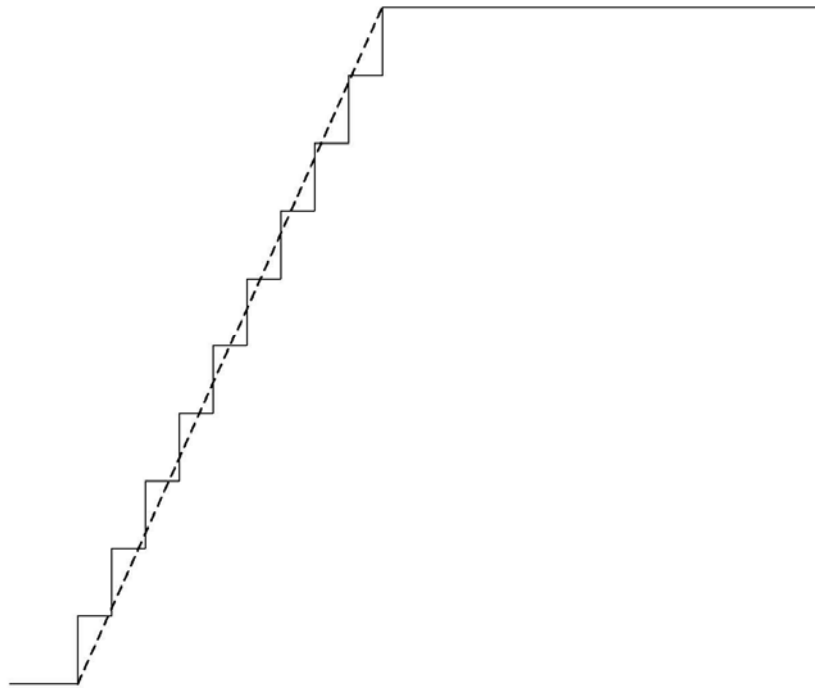

Figure 2.10 Comparison of ten-tiered wall system and continuous slope with the same total “offset” distance

² Upper bound is used here in reference to number of tiers, not the total force. Thus, the upper bound would correspond to a number of tiers that approaches some large number.

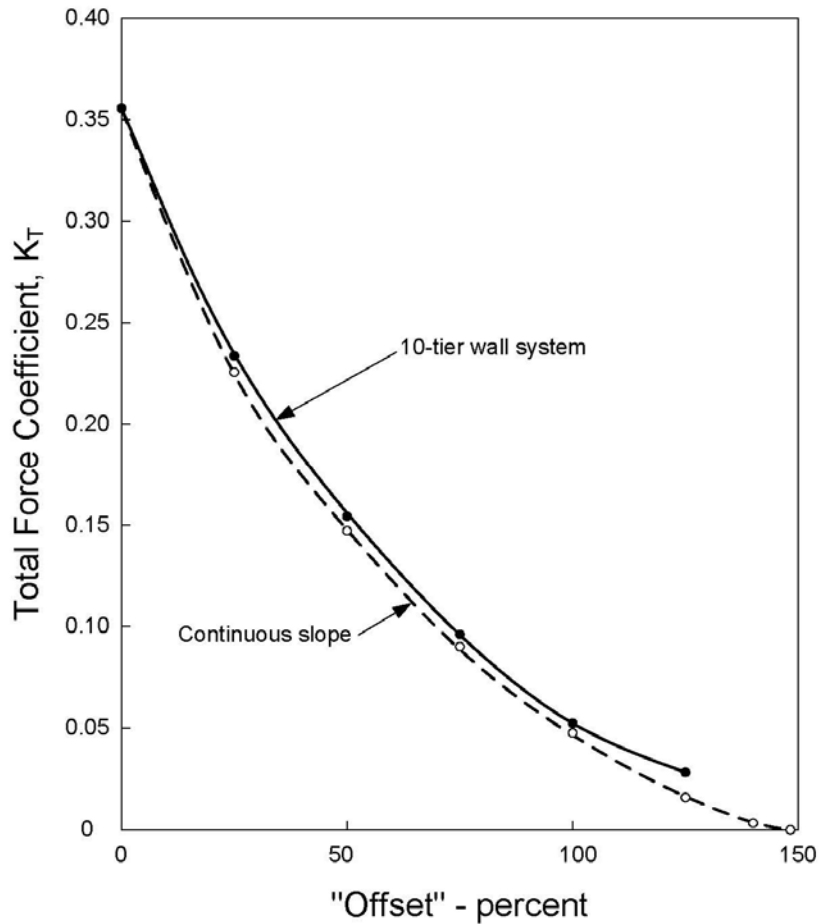

Figure 2.11 Variation in total force coefficient, K_T , with “offset” for ten-tiered wall and continuous slope

Schmertmann et al. (1987) developed a set of charts for calculating the required reinforcement force for earth slopes. Their charts were also developed using limit equilibrium analyses. They computed force coefficients equivalent to the force coefficient, K_T , defined in this study. Values were computed for a range in slope angles and for friction angles of 15, 20, 25, 30, and 35 degrees. Schmertmann et al.’s force coefficients are plotted in Figure 2.12. Also plotted in this figure are values of K_T calculated in the manner described above. Values from the current study are shown for friction angles of 24 degrees and 34 degrees. It can be seen that the values from the present study agree very well with the values determined by Schmertmann et al. Consequently, it appears that the procedures developed by Schmertmann et al. can also be used to estimate the required reinforcement forces for multi-tier walls having a large number of tiers.

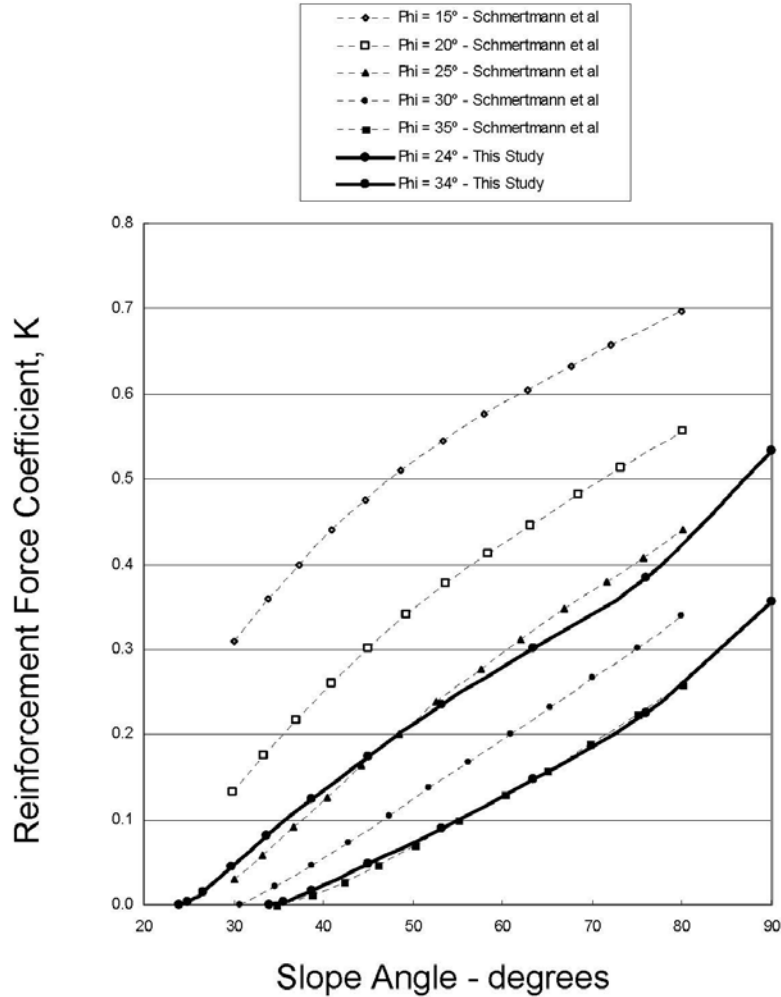

Figure 2.12 Comparison of force coefficients from Schmertmann et al. with coefficients determined in this study

Force Coefficients K_T for Various Numbers of Wall Tiers and Setbacks

The variation in the total force coefficient, K_T , with wall offset has been shown in Figures 2.9 and 2.11 for 3-tiered and 10-tiered wall systems, respectively. Additional calculations like those presented in these figures were performed for 2-, 4-, and 6-tiered wall systems. Results of all these calculations are plotted in Figure 2.13. In all cases, the pattern of variation in the coefficient, K_T , with offset distance is similar: The coefficient decreases from a value of 0.355 with increasing offset distance until it reaches a minimum value that depends on the number of tiers. The minimum values for K_T are expressed by Eq. 2.10. For offsets that exceed the offset where the minimum coefficient is first reached, the wall systems behave as a series of isolated, independent single walls with regard to the forces that the reinforcement must provide.

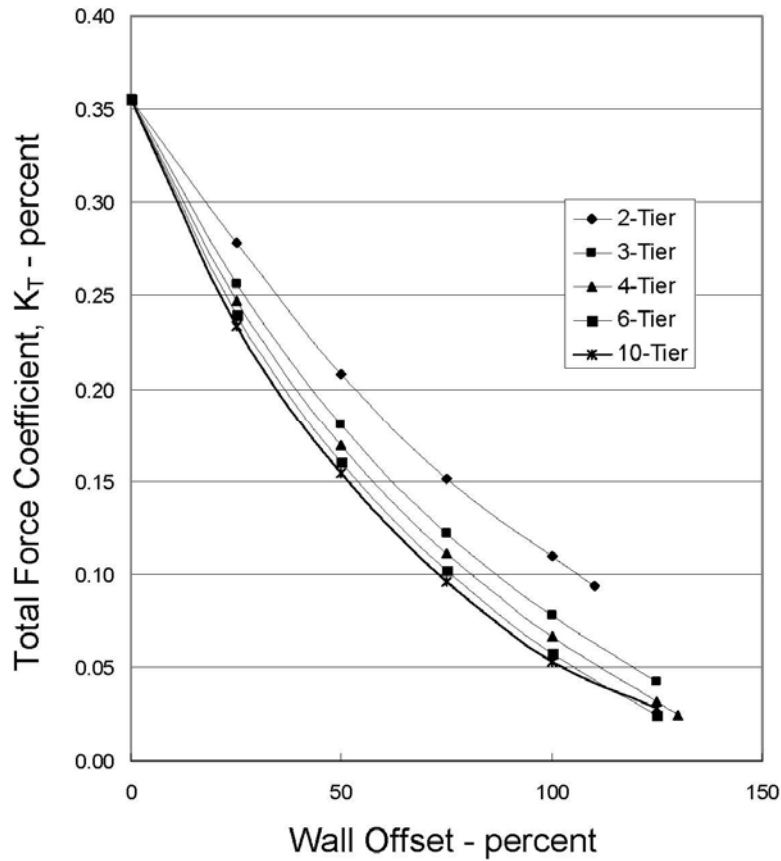

Figure 2.13 Variation in total force coefficient, K_T , with wall offset for 2, 3, 4, 6, and 10 tier wall systems

Influence of Factor of Safety and Soil Shear Strength

FHWA guidelines are based on calculating the earth pressure forces that the reinforcement can resist assuming that the full shear strength of the soil is developed. This is consistent with the way that earth pressures are typically calculated. In the FHWA guidelines, once the forces due to these pressures are calculated, the forces are compared to the “factored,” long-term, allowable reinforcement forces to determine that the reinforcement is adequate. In effect, any factor of safety that exists is applied to the reinforcement resistance and not to the soil shear strength.

The approach used to define reinforcement forces for walls is different from what is usually done for reinforced earth slopes. For reinforced slopes, the shear strength is reduced by a factor of safety before the reinforcement forces are calculated, i.e., the reinforcement forces are based on the shear strength not being fully developed. This is the primary reason why Schmertmann et al.’s charts present earth pressure coefficients for a range in friction angle. The charts are normally used by first factoring the shear strength to compute a developed friction angle, ϕ_d , defined by,

$$\phi_d = \arctan\left(\frac{\tan \phi}{F}\right) \quad (\text{Eq. 2.13})$$

where F is the desired factor of safety with respect to shear strength. The developed (factored) f is then used with Schmertmann et al.'s charts to determine the appropriate force coefficient. In the case of earth slopes and Schmertmann et al.'s charts, it seems reasonable to apply a factor of safety to shear strength, because this is the way factors of safety are defined for unreinforced slopes; for unreinforced slopes the factor of safety is always applied to the soil shear strength. However, this approach for defining a factor of safety and computing required reinforcement forces for reinforced slopes is very different from the one used for MSE retaining walls.

It is very likely that the two different practices for defining factors of safety and required reinforcement forces for reinforced walls versus reinforced slopes will continue. However, for multi-tiered walls, the appropriate practice and definition of factor of safety are not obvious. It has already been shown that tiered walls with a large number of tiers approach a continuous slope and, thus, the approaches used for slopes might be most appropriate. In contrast, walls that have large separations or very little offset are very similar to single, vertical walls and the approaches commonly used for single walls seem appropriate. Currently there is no way to convincingly argue that one approach is more valid than another. However, it is important that any approach be used consistently and the factors of safety that are applied will depend very much on what approach is taken and how the factors of safety are defined.

Regardless of what approach is used to compute the required reinforcement force, it seems useful to know how the forces will vary depending on the developed friction angle. The preceding calculations were all based on an assumed friction angle for the reinforced soil of 34 degrees. This value (34 degrees) seems reasonable for most quality backfill used in MSE walls. To examine the potential effect of the developed friction angle, an additional series of computations similar to those presented above was performed for a friction angle of 24 degrees. Twenty-four degrees is very close to the developed friction angle computed from Eq. 2.13 if the actual friction angle is 34 degrees and a factor of safety of 1.5 is assumed, i.e.,

$$\phi_d = \arctan\left(\frac{\tan 34^\circ}{1.5}\right) = 24.2^\circ \quad (\text{Eq. 2.14})$$

Total force coefficients, K_T , were again calculated for 2-tier and 6-tier wall systems and a range in wall offsets. These coefficients are shown along with the corresponding values calculated for a developed friction angle of 34 degrees in Figure 2.14. Clearly the coefficients are different depending on the friction angle.

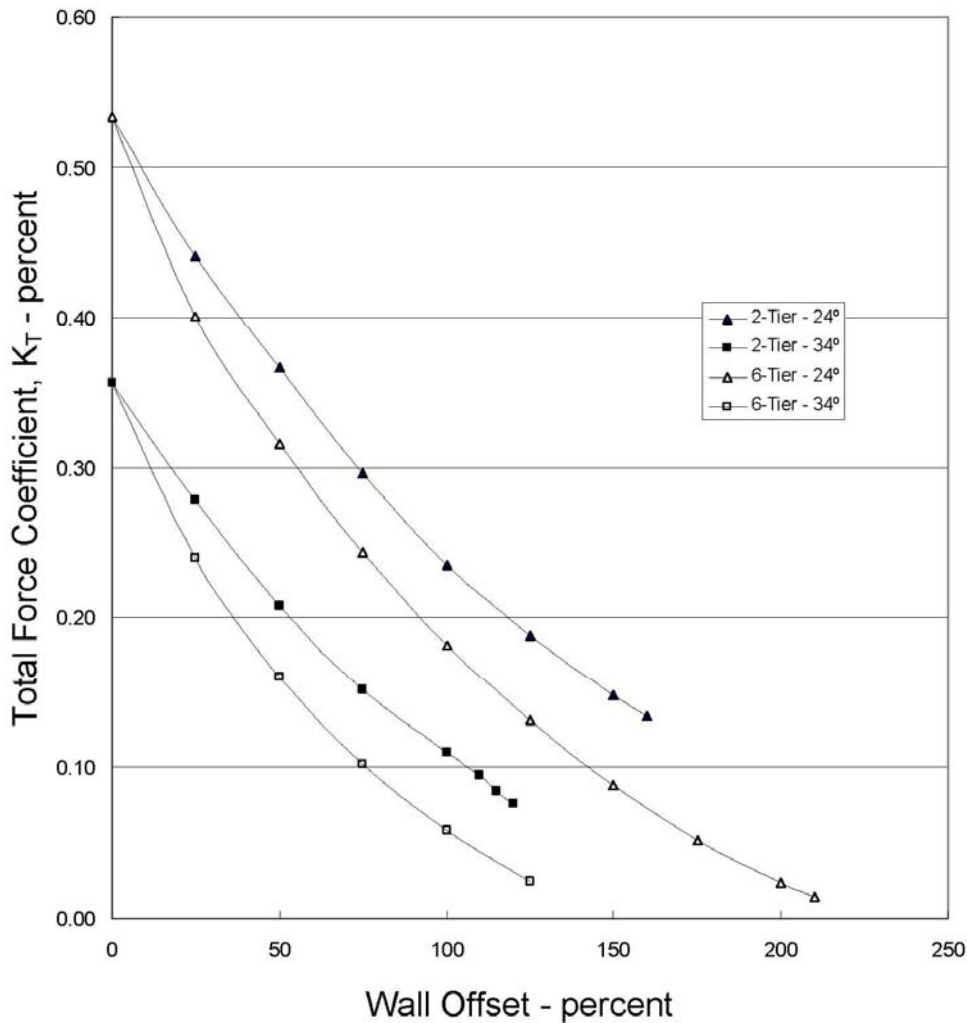

Figure 2.14 Variation in total force coefficient, K_T , with wall offset for 2 and 6 tier wall systems with friction angles (ϕ) of 24 and 34 degrees

In order to generalize the results shown in Figure 2.14, the coefficients K_T were normalized by dividing them by the corresponding active Rankine earth pressure coefficient given by Eq. 2.5. The resulting plot is shown in Figure 2.15. There are still separate curves depending on the assumed friction angle and, of course, the number of wall tiers. Further examination of the data suggested that the values shown in Figure 2.15 might be replotted by expressing the offset by an “offset ratio,” R_s . The offset ratio is defined as the offset divided by the minimum offset for which no reinforcement is required for stability (Figure 2.16). The minimum offset where no reinforcement force is required can be calculated from Eq. 2.12 using a slope angle equal to the developed friction angle, i.e., $\beta = \phi_d$. That is, a slope in cohesionless soil should be stable with no reinforcement when the slope angle is equal to the (developed) friction angle. The plot of normalized force coefficient, K_T/K_A , versus offset ratio, R_s , is shown in Figure 2.17. It can be seen that the relationships shown in this figure for a given number of wall tiers, e.g., 2-tiers, are very similar and nearly independent of the assumed friction angle. The results shown in Figure 2.17 suggest that the coefficients shown earlier in Figure 2.13

could be replotted in the normalized form shown in Figure 2.12 to determine force coefficients for friction angles other than 34 degrees if necessary.

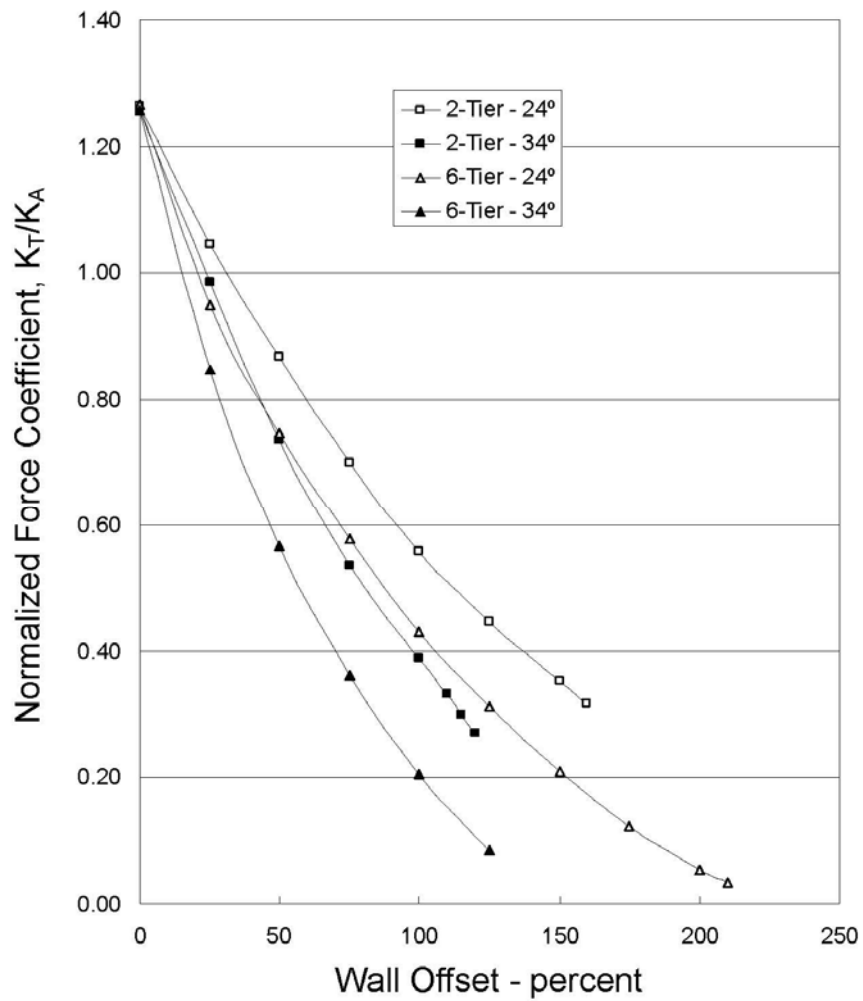
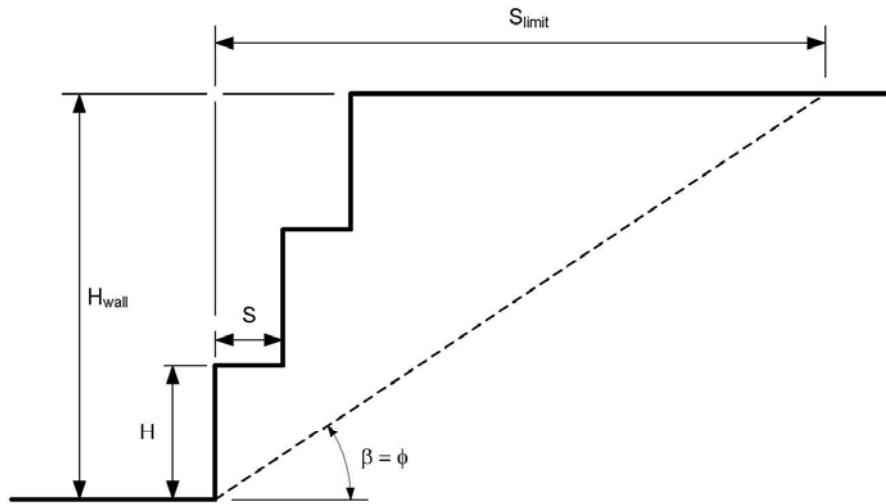

Figure 2.15 Variation in normalized total force coefficient, K_T/K_A , with wall offset for 2- and 6-tier wall systems with friction angles (ϕ) of 24 and 34 degrees



$$\text{Offset fraction, } s_r = \frac{S}{H}$$

$$\text{Limiting offset fraction, } s_l = \frac{S_{limit}}{H_{wall}} = \frac{1}{\tan \beta} = \frac{1}{\tan \phi}$$

$$\text{Offset ratio, } R_s = \frac{s_r}{s_l} = s_r \tan \phi$$

Figure 2.16 Illustration of “offset ratio,” R_s , for multi-tiered wall systems

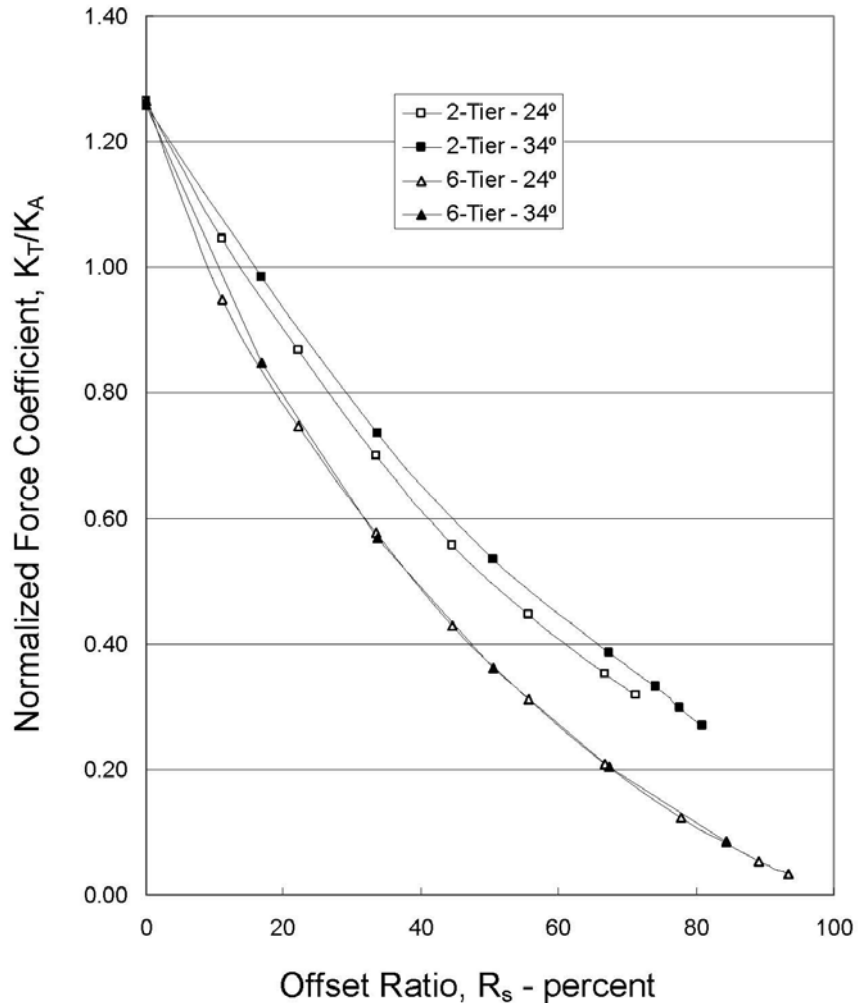

Figure 2.17 Variation in normalized total force coefficient, K_T/K_A , with offset ratio, R_s , for 2 and 6 tier wall systems with friction angles (ϕ) of 24 and 34 degrees

Summary

Procedures have been developed and presented in this chapter for computing the total required forces for multi-tiered walls. Charts are presented for calculating the forces for simple wall geometries. Also, the procedures outlined and used to develop the charts can be used to determine the required reinforcement for other, more complex wall geometries using conventional limit equilibrium slope stability analysis procedures. Application to more complex walls is addressed further in Chapter 7.

The procedures presented for computing the required reinforcement forces are based on the assumption that the reinforcement is long enough to contain the critical slip surface, i.e., the critical slip surface intersects all layers of reinforcement. For actual design, a minimum, finite length required to produce an adequate factor of safety with these forces must then be determined. Procedures for determining the required length are presented in the next chapter.

Table 2.1 - Total required reinforcement forces computed from limit equilibrium analyses for a 10-foot high wall with 10 layers of reinforcement

Variation in Reinforcement Force with Depth	Total Required Force - pound per lineal foot of wall	Total Force Coefficient, K_T
Linearly increasing	1696	0.283
Constant	2131	0.355

Table 2.2 - Factors of safety on shear strength and corresponding developed friction angles required for reinforcement forces computed from limit equilibrium analyses to match those computed by FHWA guidelines (Reinforcement forces constant with depth)

Wall Height (meters)	Metal Bar Mats and Welded Wire Grid		Metal Strips	
	Factor of Safety	Developed Friction Angle, ϕ_d (degrees)	Factor of Safety	Developed Friction Angle, ϕ_d (degrees)
0	2.26	16.65	1.35	26.60
1	2.05	18.25	1.30	27.42
2	1.86	19.93	1.26	28.25
3	1.70	21.70	1.21	29.12
4	1.55	23.55	1.17	30.02
5	1.41	25.50	1.12	30.96
6	1.29	27.58	1.08	31.94
7	1.20	29.36	1.05	32.76
8	1.14	30.59	1.03	33.31
9	1.10	31.48	1.01	33.70
10	1.07	32.14	1.00	33.98
11	1.05	32.64	0.99	34.19
12	1.04	33.03	0.99	34.36
13	1.03	33.34	0.98	34.48
14	1.02	33.59	0.98	34.59
15	1.01	33.79	0.98	34.67

Table 2.3 - Calculated values for total required force and coefficient K_T for four, three-tiered walls with 50 percent setback

Case	Individual Wall Heights (feet)	Unit Weight of Soil	Total required Reinforcement Force (pounds)	Total Force Coefficient, K_T
I	10	100	8,116	0.180
II	10	125	10,144	0.180
III	20	125	40,578	0.180
IV	40	100	129,848	0.180

Chapter 3 - Estimation of Reinforcement Lengths

Introduction

Conventional design practice for MSE walls is to first estimate the forces and lengths of reinforcement required and then check external and internal stability to insure that the forces and lengths are sufficient. If the forces and lengths are not sufficient, they are increased until stability requirements are satisfied. For single-tiered walls, the reinforcement length is typically estimated to be 0.7 times the wall height. This chapter investigates similar simple guidelines that can be used to estimate the lengths of reinforcement for multi-tiered walls. Particular emphasis is placed on the lengths required for global stability. Emphasis is also placed on a procedure for estimate lengths, which is consistent with the procedures used to estimate lengths for single-tiered walls and for reinforced slopes.

Required Reinforcement Lengths for Base of Wall System

Reinforcement length requirements for single-tier walls provide a useful basis for establishing lengths for multi-tiered walls. Accordingly, the requirements for single-tiered walls are discussed first, followed by those for multi-tiered walls.

Single-Tiered Walls

Initial reinforcement lengths of 0.7 times the wall height typically yield suitable lengths for stability of single-tiered MSE walls. The minimum factor of safety for global stability with these reinforcement lengths ($0.7 \times H$) will depend on the strength of the soil and the strength of the reinforcement. However, if the reinforcement is very strong, the critical slip surface will pass entirely outside the reinforced soil and the factor of safety will then depend only on the shear strength of the unreinforced (“retained”) soil. To illustrate this, consider the wall shown in Figure 3.1. The reinforced soil is assumed to be sufficiently strong to force the “critical” (lowest factor of safety) slip surface entirely outside the reinforced soil. The unreinforced soil is assumed to have a friction angle of 30 degrees, which is suggested in the FHWA guidelines (Elias et al. 2001) as a representative lower-bound value for retained soil. Stability computations were performed using the Simplified Bishop procedure to locate the slip surface with the minimum factor of safety. The “critical” slip circle is shown in Figure 3.1 and has a minimum factor of safety of 1.54. Any wall with soil having a friction angle of 30 degrees will have this same factor of safety (1.54) as long as the reinforcement length is 0.7 times the wall height and the reinforcement is strong enough to force the critical slip surface entirely outside the reinforced soil mass. This is further illustrated by the four walls shown in Figure 3.2. The heights and soil unit weights for these walls vary, but the soil strength is the same for all walls and the reinforcement lengths are 0.7 times the wall height. All four walls have the same minimum factor of safety (1.54) for slip surfaces passing outside the reinforced soil mass.

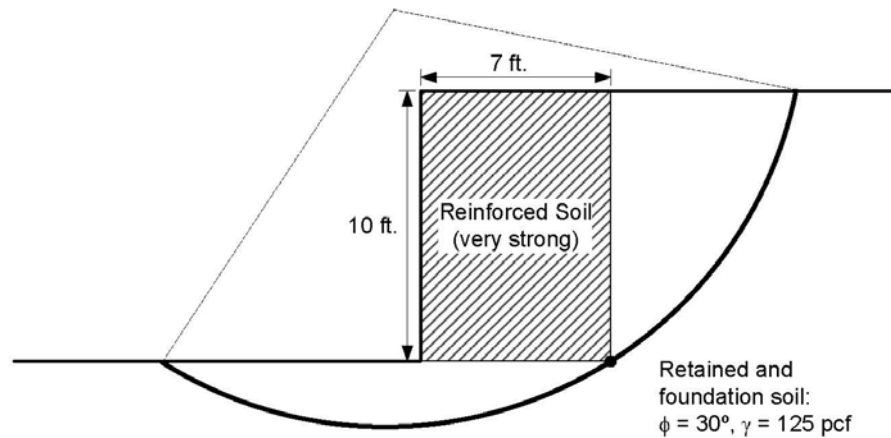

Figure 3.1 Critical slip circle through heel of “standard” reinforced wall section

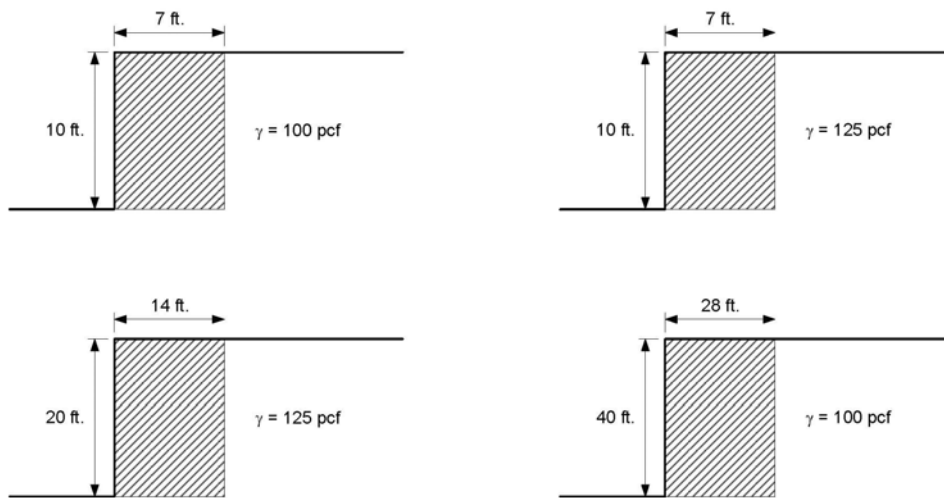

Figure 3.2 Four walls to illustrate uniqueness of minimum factor of safety for slip surfaces through the “heel” of the reinforced soil mass — all walls have a minimum factor of safety of 1.54

In the calculations presented above, the results were expressed in terms of a factor of safety. The factor of safety was unique for a given reinforcement length of $0.7 \times H$ and a friction angle of 30 degrees, but the factor of safety will vary with the friction angle. Instead of expressing the results of the stability calculations in terms of a factor of safety, it is convenient to express the results in terms of a “developed” friction angle, ϕ_d . The developed friction angle, ϕ_d , is defined as follows:

$$\tan \phi_d = \frac{\tan \phi}{F} \quad (\text{Eq. 3.1})$$

where ϕ is the actual friction angle and F is the computed factor of safety. The developed friction angle can also be expressed by,

$$\phi_d = \arctan\left(\frac{\tan \phi}{F}\right) \quad (\text{Eq. 3.2})$$

For the preceding calculations the developed friction angle is thus computed as,

$$\phi_d = \arctan\left(\frac{\tan \phi}{F}\right) = \arctan\left(\frac{\tan 30^\circ}{1.54}\right) = 20.6^\circ \quad (\text{Eq. 3.3})$$

The developed friction angle of 20.6 degrees is uniquely related to the reinforcement length and is independent of the wall height, unit weight of soil, and actual friction angle. If the developed friction angle is known, the factor of safety can always be computed by rearranging Eq. 3.1 as,

$$F = \frac{\tan \phi}{\tan \phi_d} \quad (\text{Eq. 3.4})$$

Thus, if we are interested in the factor of safety that the above walls would have if the friction angle were 34 degrees instead of 30 degrees, the factor of safety can be computed from Eq. 3.4 as follows:

$$F = \frac{\tan 34^\circ}{\tan 20.6^\circ} = 1.79 \quad (\text{Eq. 3.5})$$

Procedure for Multi-Tiered Walls

Although the above calculations assume that the reinforcement is strong enough to force the critical slip surface outside the reinforced soil mass, the calculations provide a useful basis for estimating required reinforcement lengths for multi-tiered walls. The calculations for single-tiered walls showed that for reinforcement lengths equal to 0.7 times the wall height the developed friction angle is 20.6 degrees, independent of wall height, actual value of ϕ , and soil unit weight. A developed friction angle of 20.6 degrees can then be used as a criterion for establishing reinforcement lengths for multi-tiered walls. By doing so it can be assured that multi-tiered walls will have the same global factors of safety as single tiered walls for slip surfaces passing outside the reinforced soil. For slip surfaces that pass through some or all of the reinforced soil, the factors of safety may be different and will depend on the forces in the reinforcement as well as the reinforcement length. This aspect will be addressed later in Chapter 4.

To determine the reinforcement length required to produce a developed friction angle of 20.6 degrees for a multi-tiered wall, a trial and error procedure was used. Slope stability calculations were performed to locate the most critical circle passing through an assumed point representing the “heel” of the reinforced soil (Figure 3.3). The distance, L_B , between the heel point and the toe of the wall was varied and slope stability calculations were performed to locate the critical circle for each location of the “heel” point. All calculations were performed using a friction angle of 30 degrees. The developed friction angle for each location of the heel point was then calculated using Equation 3.1 and the computed minimum factor of safety. Actually, any friction angle

could have been assumed because the developed friction angle is independent of what is assumed for the actual value of ϕ .

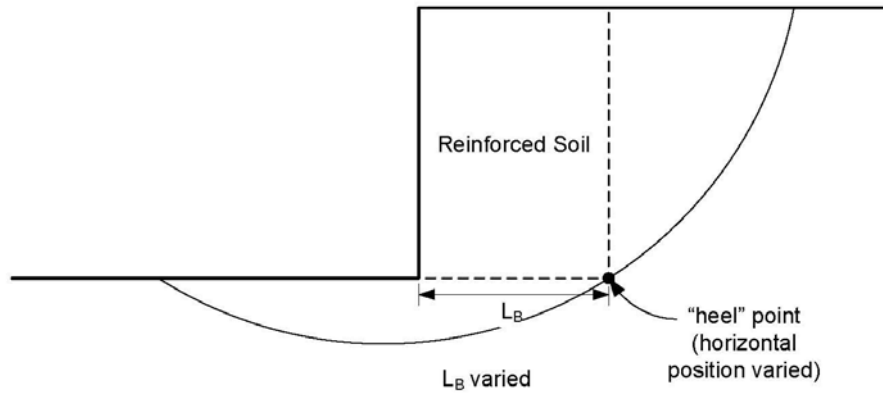

Figure 3.3 Slip circle through “heel” of reinforced wall section

To illustrate the above procedure, calculations were performed for the three-tier wall system with a 150 percent offset shown in Figure 3.4. The variation in the developed friction angle with the “base” length, L_B , is shown in Figure 3.5. The base lengths, L_B , have been normalized by dividing them by the total wall height (all tiers included), making the results independent of wall height. It can be seen from this figure that a normalized base length, L_B/H_{total} , of approximately 0.96 produces a developed friction angle of 20.6 degrees. Longer base lengths will produce lower developed friction angles (higher factors of safety).

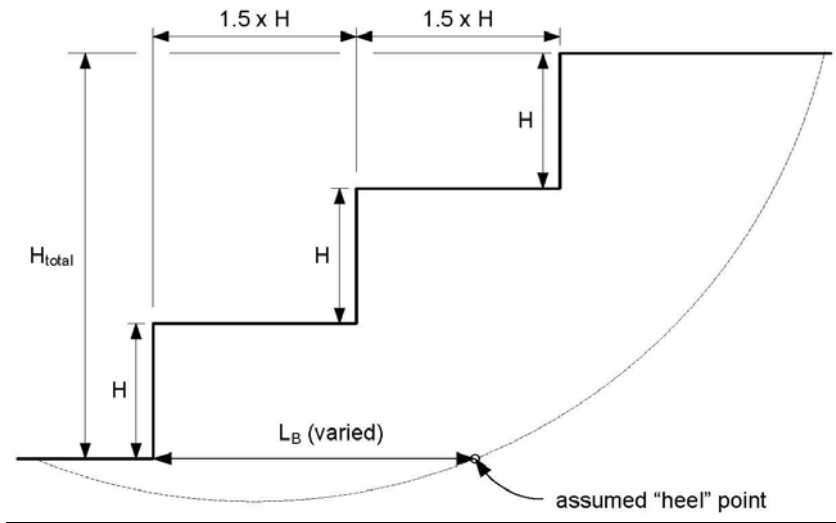

Figure 3.4 Example three-tiered wall system with 150 percent wall setbacks

Variation in Required Reinforcement Length with Wall Setback

Computations like those illustrated in Figure 3.5 were performed for various amounts of wall offset. The variation in the required base length with wall offset is shown in

Figure 3.6 for a three-tiered wall system. The base lengths are again normalized by dividing them by the total wall height. The normalized base lengths, L_B/H_{total} , start at a value of 0.7 corresponding to a wall with no offset, which is the same as a single wall. The values then increase to a maximum of approximately 0.96 at offsets of 125–150 percent and then decrease. The minimum normalized base length corresponds to the point where wall offset is so large the wall system acts as separate, independent walls³. At this point, the normalized base length is given by,

$$\frac{L_B}{H_{total}} = \frac{0.7}{n_{tiers}} \quad (\text{Eq. 3.6})$$

where n_{tiers} is the number of tiers.

Equation 3.6 becomes more obvious when it is recognized that,

$$H_{total} = n_{tiers} \times H \quad (\text{Eq. 3.7})$$

where H is the height of an individual tier. Combining Eq. 3.6 and 3.7 gives,

$$L_B = \frac{0.7}{n_{tiers}} H_{total} = \frac{0.7}{n_{tiers}} n_{tiers} \times H = 0.7 H \quad (\text{Eq. 3.8})$$

For the three-tiered wall system represented in Figure 3.6 at offsets exceeding approximately 250 percent the required lengths are expressed by,

$$\frac{L_B}{H_{total}} = \frac{0.7}{3} = 0.23 \quad (\text{Eq. 3.9})$$

which gives lengths identical to the required length for single-tiered walls.

³ It should be noted that the amount of wall offset where walls act as independent walls in terms of *required base length*, L_B , may be different from the offset where walls act as independent walls in terms of the *required force*, as discussed earlier in Chapter 2.

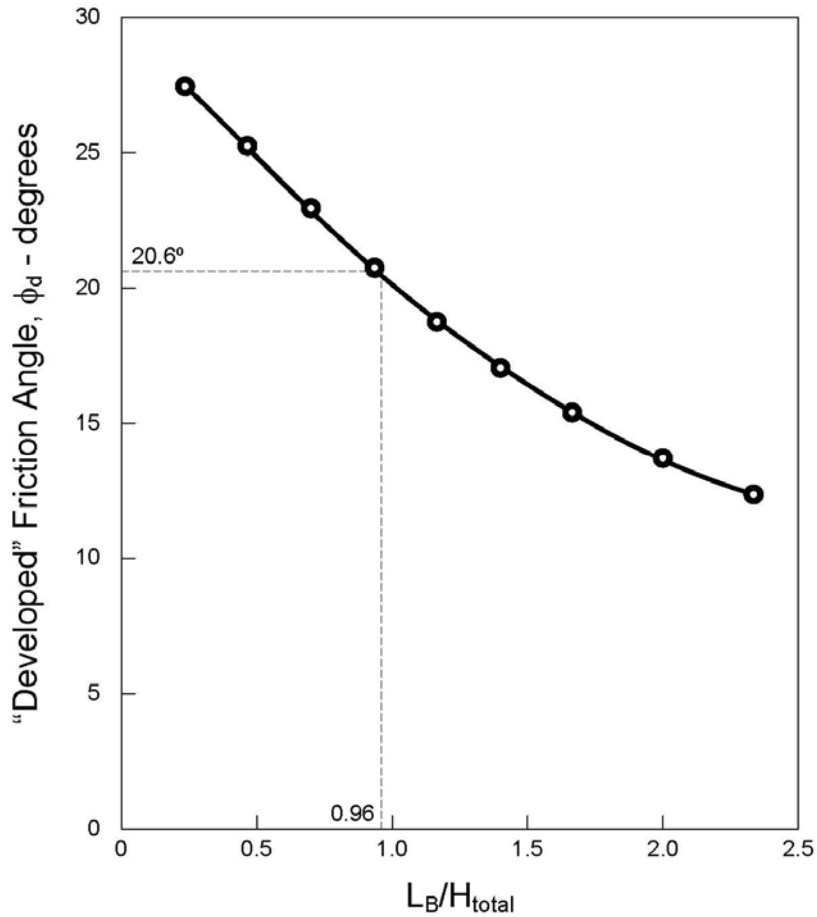

Figure 3.5 Variation in developed friction angle with normalized length of bottom reinforcement for three-tiered wall with 150 percent setback

The results presented in Figure 3.6 show that the required reinforcement length increases with the amount of wall offset for offsets up to about 125–150 percent of the individual wall height (H). Initially this may seem unusual and contrary to what one might expect. One might expect that increasing the offset would increase stability and thereby decrease length requirements for reinforcement. However, the increase in length requirements with offset distance that is shown in Figure 3.6 seems to be related to overall stability and safety against global sliding. This can be illustrated by the two idealized “wall” systems shown in Figure 3.7. Both wall systems have the same total height and the same base length for the reinforced zone. Also the total force (P_1 , P_2) on the back of the “wall” system should be comparable. However, the wall system with no “offset” has a greater total weight than the wall system with some offset. Thus, the wall system with no offset will have a greater resistance to sliding. This will be particularly true in a frictional material, as is assumed throughout this chapter, where all strength is derived from the normal stresses (σ). For the second wall system with offset, the base length of the reinforced section will need to be greater to have the same resistance to sliding as the wall with no offset. This most likely explains why the normalized base lengths, L_B/H_{total} , shown in Figure 3.6, initially increase with offset distance.

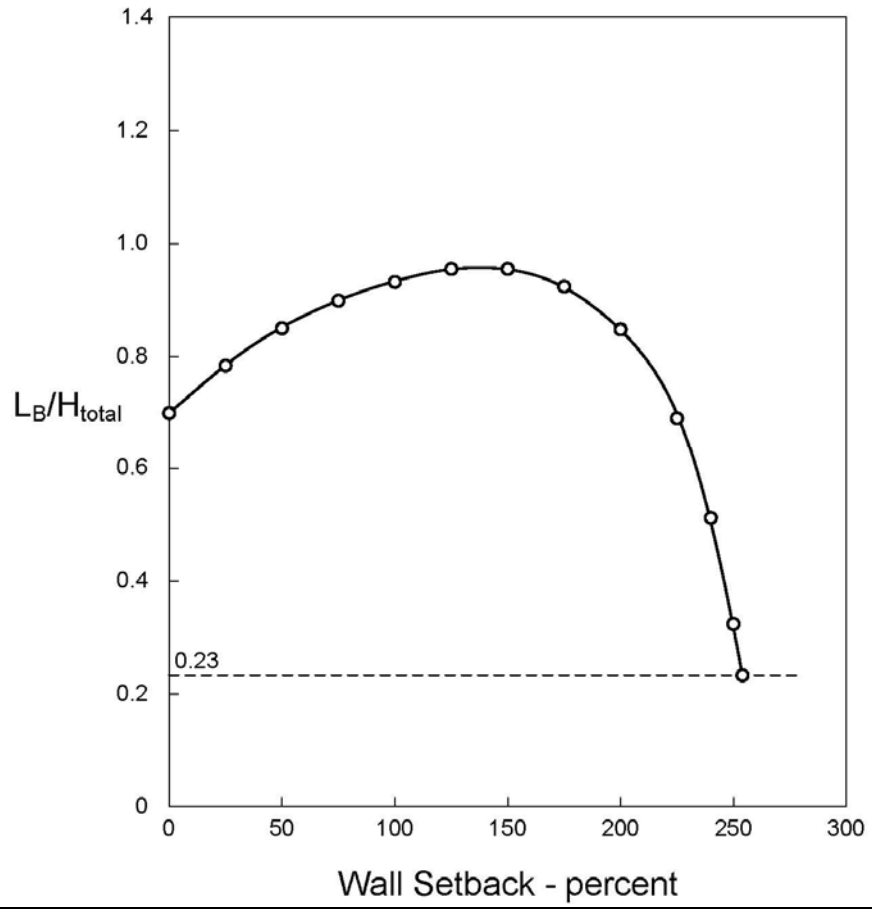

Figure 3.6 Variation in normalized length of bottom reinforcement with wall setback

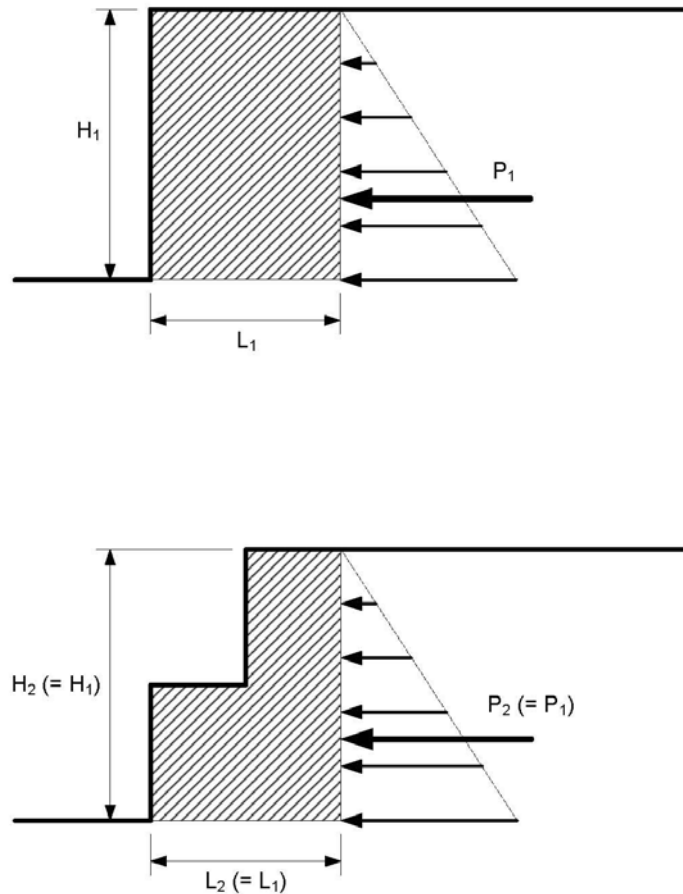
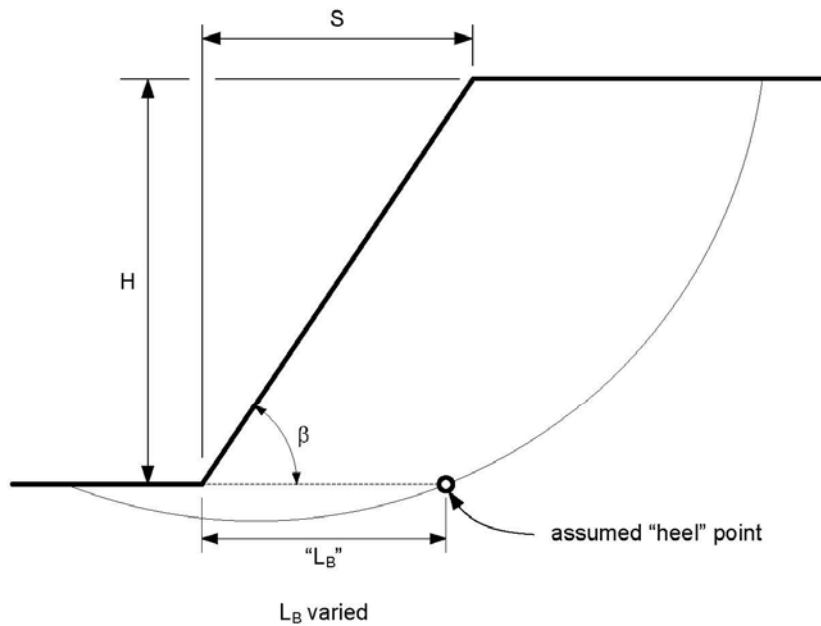

Figure 3.7 Schematic for sliding of single and tiered wall systems with comparable base lengths

Relationship Between Multi-Tiered Walls and Slopes

As the number of tiers for a multi-tiered wall system increase it seems reasonable again to expect that from a global stability perspective, the wall system should be similar to a slope, including similar requirements for the reinforcement. Thus, it is of interest to examine the required lengths of reinforcement for a slope using procedures like the ones discussed above. For a given slope, computations were performed for various assumed “heel” points to find the distance producing a developed friction angle of 20.6 degrees (Figure 3.8). The corresponding “offset,” S , for a slope expressed as a ratio, S/H , to slope height is equal to the cotangent of the slope angle, β (Figure 3.8). The required base lengths, expressed as ratios, L_B/H_{total} , are plotted versus “offset” distance in Figure 3.9 for a ten-tiered wall system and a continuous slope. It can be seen in this figure that the required reinforcement lengths are very similar, thus confirming the similarities between a continuous slope and a tiered wall system with many tiers.



$$\frac{S}{H} = \cot(\beta)$$

Figure 3.8 Continuous slope representation

Schmertmann et al. (1987) presented a chart for the required length of reinforcement at the base of continuous slopes for various assumed developed friction angles. Their results are plotted in Figure 3.10 along with the results presented in Figure 3.9 for a continuous slope. It can be seen that the results from this study, based on a developed friction angle of 20.6 degrees, agree very well with those from Schmertmann et al.'s work, even though the required reinforcement lengths were determined by somewhat different procedures and independently of each other. Schmertmann et al.'s work has been widely circulated and used for design. Thus, the close agreement between the current work and Schmertmann et al.'s provides encouragement for the approach suggested herein.

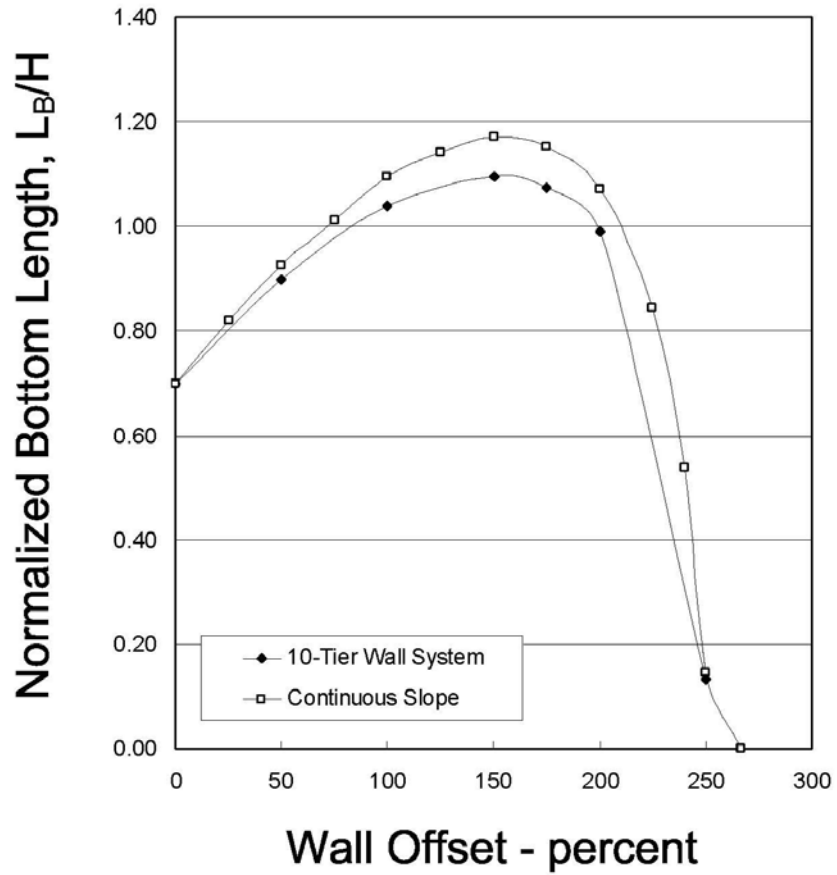

Figure 3.9 Variation with wall offset in required values of normalized bottom length, L_B/H_{total} for a 10 tier wall system and continuous slope

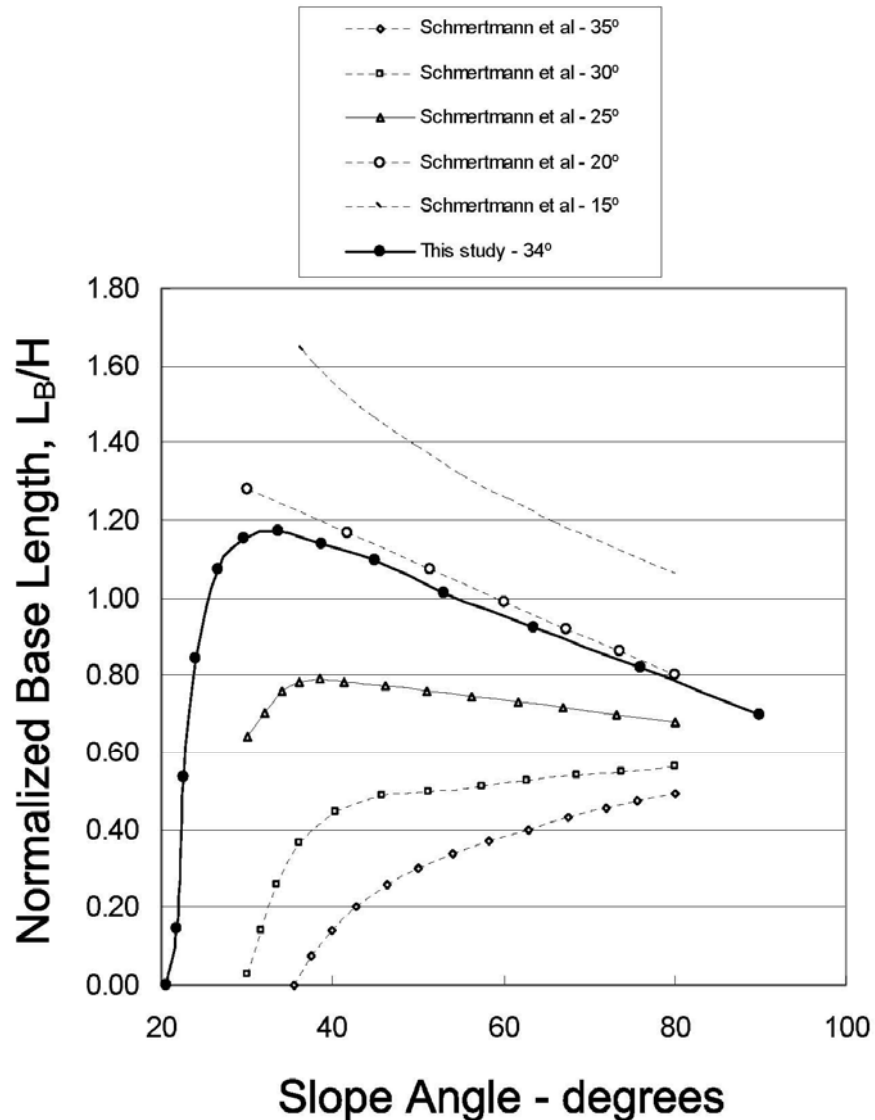

Figure 3.10 Comparison of required values of normalized base length, L_B/H_{total} , from Schmertmann et al. with values determined in this study

Required Reinforcement Base Lengths for Various Numbers of Tiers and Wall Setbacks

Results of computations for the required base length, L_B , are presented in Figure 3.11 for 2-, 3-, 4-, 6-, and 10-tiered walls. The values in this figure can be used to estimate the required lengths of reinforcement at the base of multi-tiered wall systems.

As an example of the use of Figure 3.11 to determine the required base length of reinforcement, consider the 4-tiered wall shown in Figure 3.12. The height of each tier is 7 feet and the offset distance is 4 feet. Thus, the offset, expressed as a percentage of the individual wall height is approximately 57 percent ($= 100\% \times 4 \div 7$). From Figure 3.11 the required normalized reinforcement base length, L_B/H_{total} , is approximately 0.9. The total wall height is 28 feet ($= 4 \times 7$). Thus, the required base length, L_B , is 25.2 feet ($= 0.9 \times 28$).

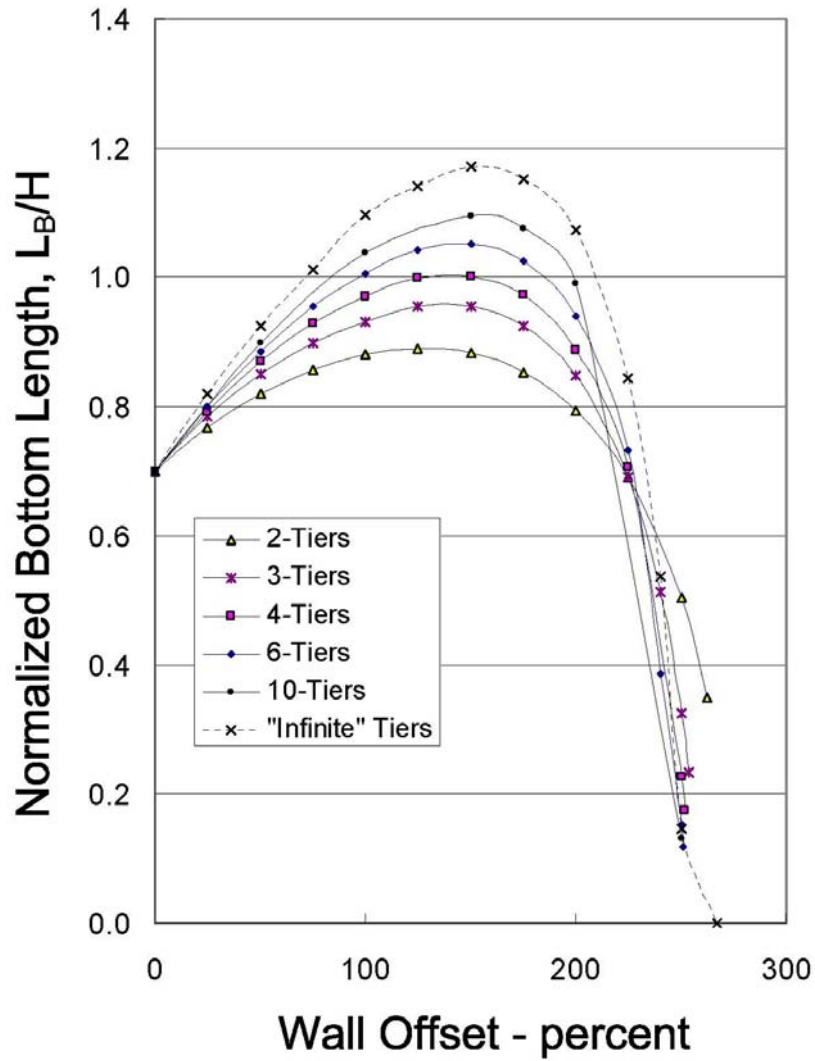

Figure 3.11 Variation with wall offset in required values of normalized bottom length, L_B/L_{total} , for reinforcement for 2, 3, 4, 6, and 10 tier wall systems and continuous slope

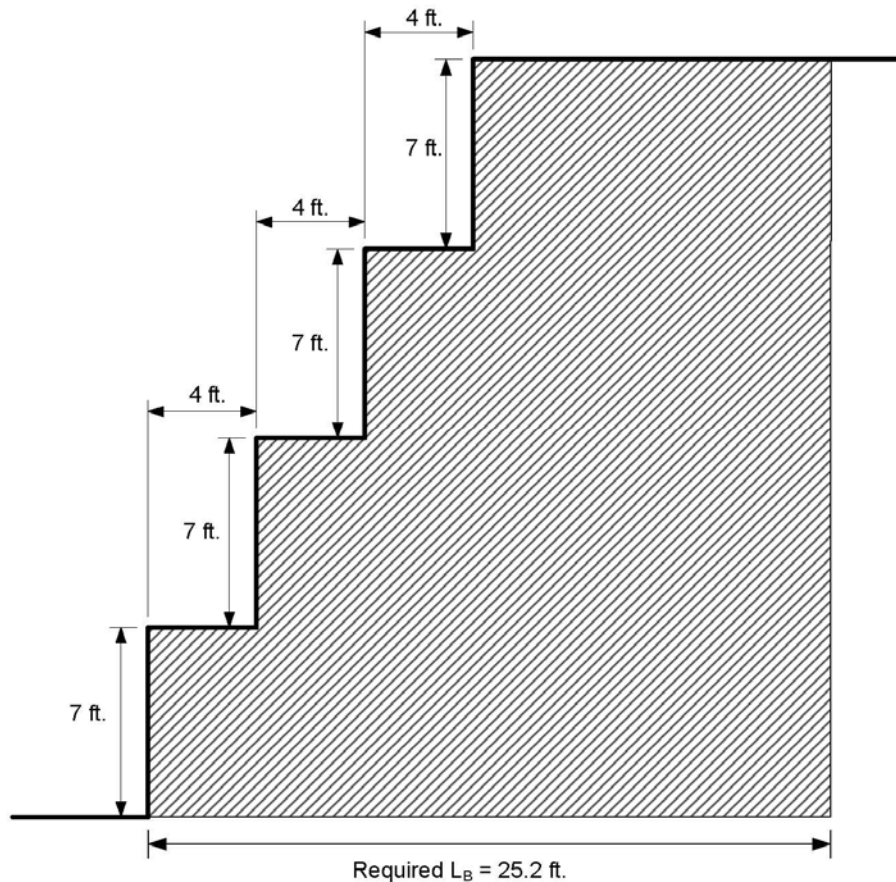

Figure 3.12 Example four-tiered wall used to illustrate calculation of required reinforcement base length

Required Lengths of Reinforcement at Top of Wall System

For single-tiered wall systems, the required reinforcement lengths are usually chosen to be constant. Thus the length of the reinforcement at all levels is equal to the length at the base of the wall, i.e., $L = 0.7 \times H$. For multi-tiered walls, the length of the reinforcement can and probably should vary from tier to tier. For example, the similarity between multi-tiered walls and slopes has been discussed earlier. For slopes, Schmertmann et al.'s charts prescribe different lengths for the top and bottom levels of reinforcement. A methodology for establishing the required lengths of reinforcement in the upper portion of MSE walls is described in this section.

Procedure for Determining Required Lengths

The required lengths of reinforcement in both MSE walls and reinforced slopes is often chosen based on the position of the critical shear plane. For MSE walls, the FHWA guidelines (Elias et al., 2001) stipulate the length of the upper levels of reinforcement based on the location of the "active" zone. The active zone is different depending on the type of reinforcement (extensible or inextensible) and according to FHWA guidelines is largest for extensible reinforcement. The active zone for extensible reinforcement is as

indicated in Figure 3.13 and depends on the friction angle for the soil. For the reinforced soil, FHWA guidelines suggest a lower-bound friction angle of 34 degrees. Thus, for the active zone shown in Figure 3.13 and a friction angle of 34 degrees, the length of the reinforcement at the top of the wall, L_T , should be approximately 0.53 times the wall height, excluding the additional length required to develop the pullout capacity of the reinforcement.

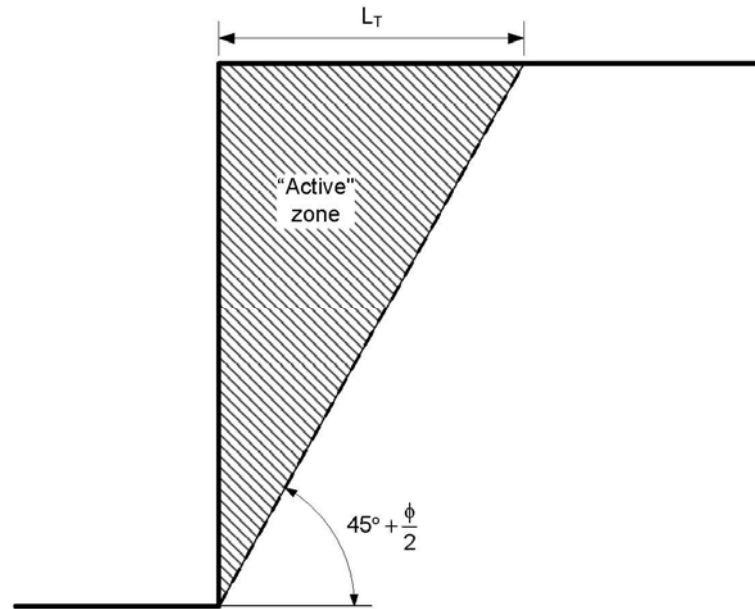

Figure 3.13 “Active” zone for extensible reinforcement according to FHWA (2001)

To establish the required length of the reinforcement near the top of a multi-tiered MSE wall, an approach similar to the one used for single-tiered walls can be used. This can be accomplished by establishing the extent of the “active” zone at the top of the multi-tiered wall system. In general, the “active” zone is defined by the slip surface producing the largest lateral load, which is also the slip surface corresponding to the maximum required reinforcement force for stability. The location of the slip surface will depend, among other things, on the vertical distribution of forces that is assumed to calculate the lateral load or reinforcement forces. This is illustrated in Figure 3.14. The critical circular slip surfaces for a single-tiered wall are shown in this figure for forces distributed uniformly (constant) with depth and for forces increasing linearly with depth. For forces increasing linearly with depth, the critical circle actually approaches a plane and is essentially identical to the critical slip surface shown in Figure 3.13. Based on the two slip surfaces shown in Figure 3.14, it appears that a more “conservative” estimate of the extent of the active zone and thus the required reinforcement lengths is obtained by assuming a linear increase in the reinforcement forces with depth. Similar comparisons to the one shown in Figure 3.14 for a single-tiered wall can be shown for multi-tiered walls. For example, the critical slip surfaces for constant reinforcement forces and reinforcement forces that increase linearly with depth are shown in Figure 3.15 for a three-tiered wall with 50 percent offset. Reinforcement forces that increase linearly with depth are again shown to define a greater extent for the active zone near the top of the wall.

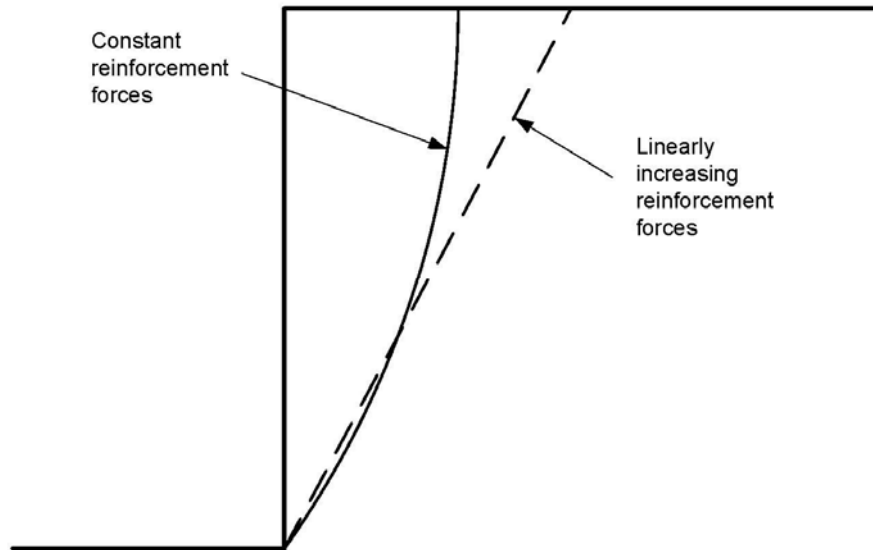

Figure 3.14 This Fig is a repeat of Fig 3.15 and is a placeholder until it can be replaced

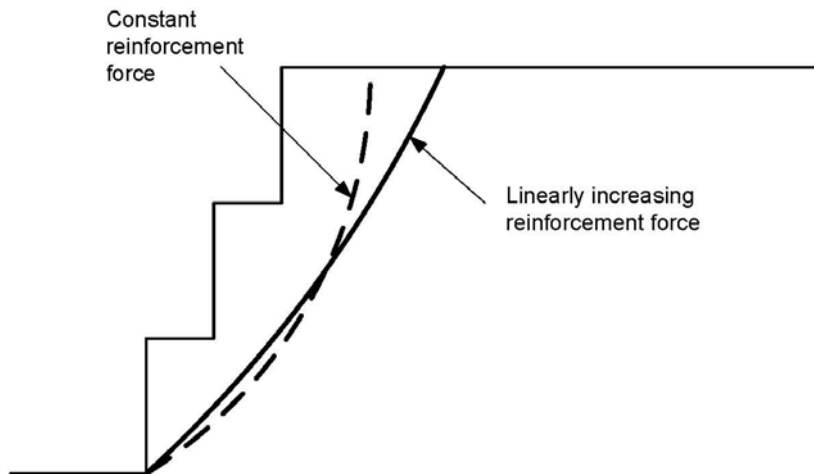

Figure 3.15 Critical slip surfaces for linearly increasing and constant reinforcement forces — three tier wall system with 50 percent setback

Based on the discussion above it appears that a reasonable, and perhaps slightly conservative, estimate of the extent of the active zone for multi-tiered walls can be found by locating the circular slip surface that produces a maximum force with the forces increasing linearly with depth. The extent of the active zone defined in this manner will depend on the assumed friction angle and the extent will increase as the friction angle decreases. A friction angle of 34 degrees was chosen for the calculations. As noted earlier, this value (34 degrees) is suggested by the FHWA guidelines as a representative lower-bound value. Once the slip surface producing a maximum force is determined, the intersection of the circle with the top surface of the wall system can be found. The distance between the intersection point and the face of the uppermost wall is taken as the length for the active zone. This length is also assumed to be the minimum required

length, L_T , of the top level of reinforcement. The lengths determined in this manner are expressed as normalized values by dividing them by the total wall height, H_{total} , and plotted versus the wall offset in Figure 3.16 for a three-tier wall system. The abrupt bend in the curve shown in this figure near offsets of approximately 110 percent is apparently a result of a transition in the shape of the slip surface from a visibly circular shape to essentially a plane similar to the one shown earlier in Figure 3.13.

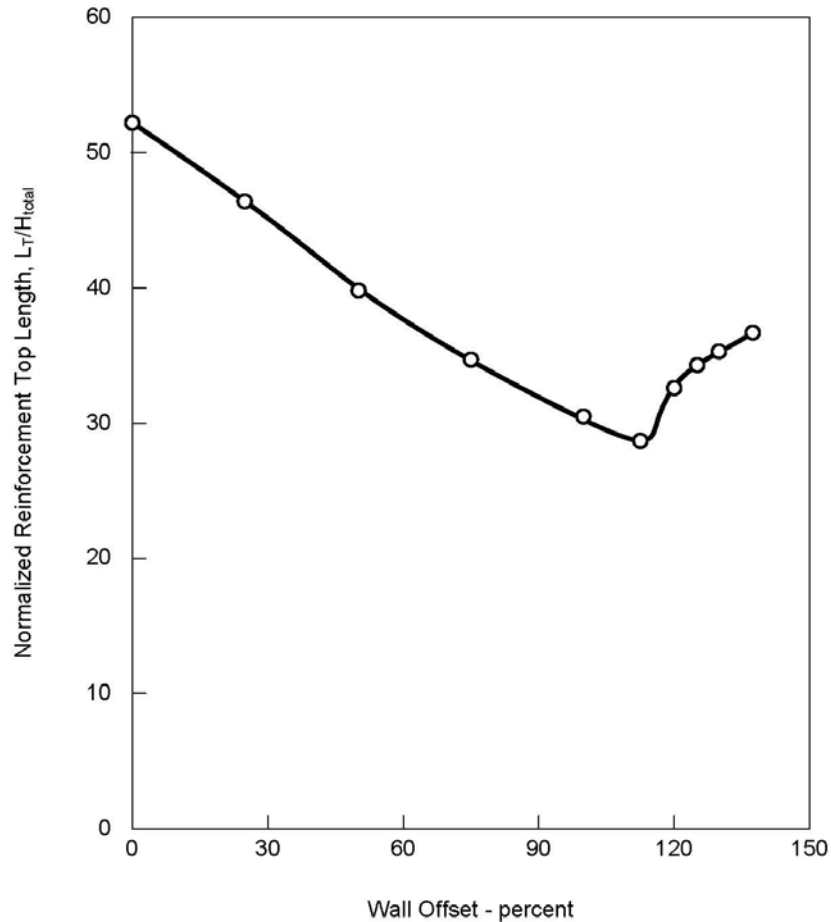

Figure 3.16 Variation in normalized top lengths for reinforcement with wall offset for a three-tiered wall system

Relationship Between Multi-Tiered Walls and Continuous Slopes

Earlier, close agreement was shown for the required reinforcement lengths at the bottom of a continuous slope based on Schmertmann et al.'s (1987) work and the procedures described in this study. Similar close agreement was found for the lengths of reinforcement at the top of a continuous slope as well. The required lengths for the reinforcement at the top of a continuous slope are shown in Figure 3.17 based on Schmertmann et al.'s chart and the procedure outlined above for multi-tiered walls. Schmertmann et al.'s results are shown for a friction angle of 35 degrees, which is close to the assumed friction angle of 34 degrees used for the present study. Relatively good

agreement can be seen between the lengths determined by both procedures, although the lengths determined in the present study are smaller.

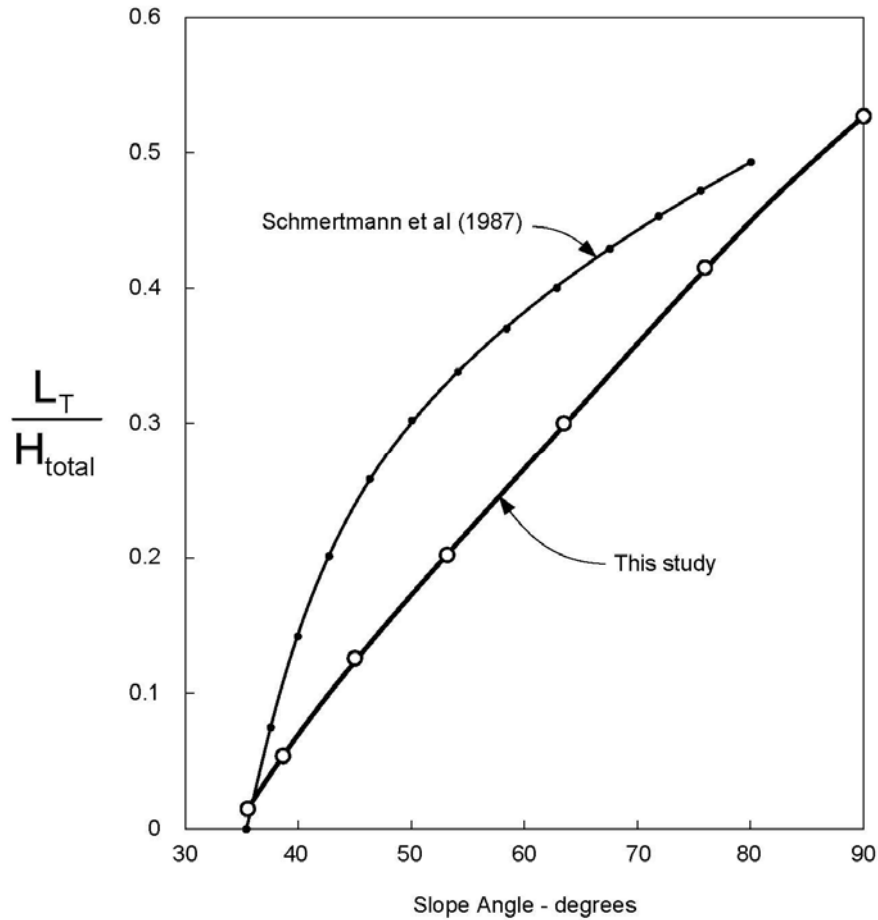

Figure 3.17 Comparison of required top length for reinforcement from Schmertmann et al. and this study for continuous slopes

Chart for Determining Required Lengths

The required lengths, L_T , of reinforcement at the top of a multi-tiered wall system are plotted in Figure 3.18. These values were determined using the procedures described above based on analyses with circular slip surfaces and the assumption that forces increase linearly with depth. The required lengths are expressed as ratios of normalized length, L_T/H_{total} and plotted versus the wall offset percentage. Values are shown for 2-, 3-, 4-, 6-, and 10-tier wall systems.

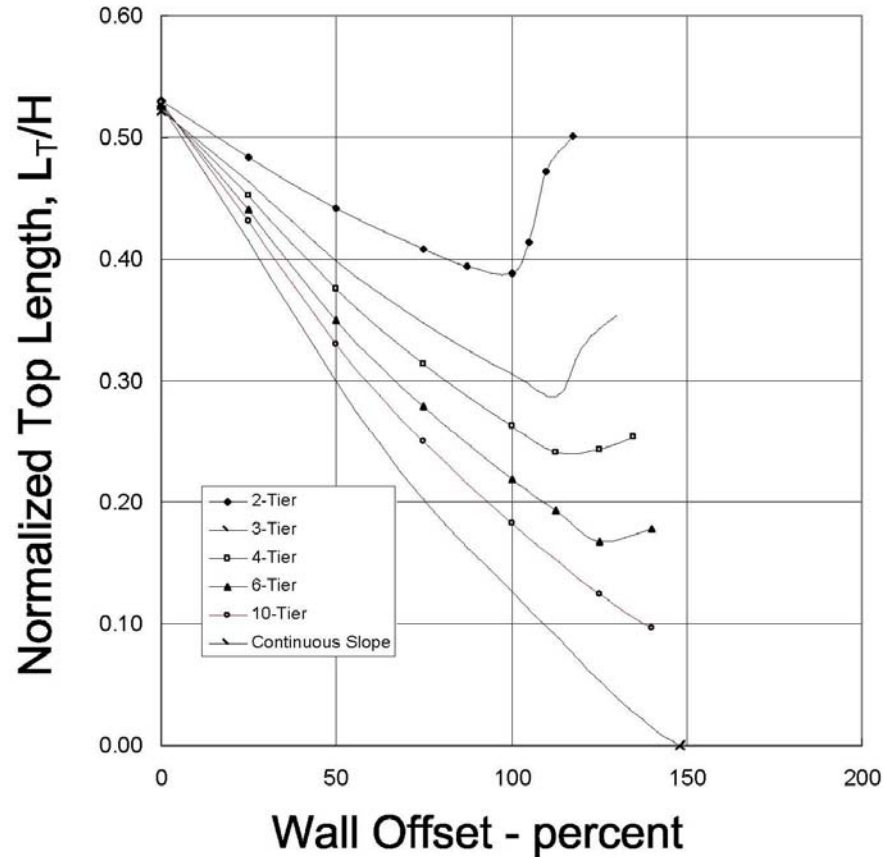

Figure 3.18 Variation with wall offset in required values of normalized top length, L_T/H_{total} , for reinforcement for 2, 3, 4, 6, and 10 tier wall systems and continuous slope

Required Lengths of Reinforcement at Intermediate Levels

The procedures and charts presented in the previous two sections can be used to determine the required reinforcement lengths at the top and bottom of a multi-tiered wall system. Usually, within a given tier, the reinforcement length will be constant. However, the lengths may vary from tier to tier. To determine the required lengths for various tiers, the lengths, L_B and L_T , can be determined using Figures 3.11 and 3.18, respectively. Once these lengths are determined, a straight line can be drawn between the required lengths at the top and bottom of the wall as shown by the line A-B in Figure 3.19. The lengths for individual tiers are then determined such that the reinforcement extends to or beyond the line A-B, as shown by the hatched regions in Figure 3.19.

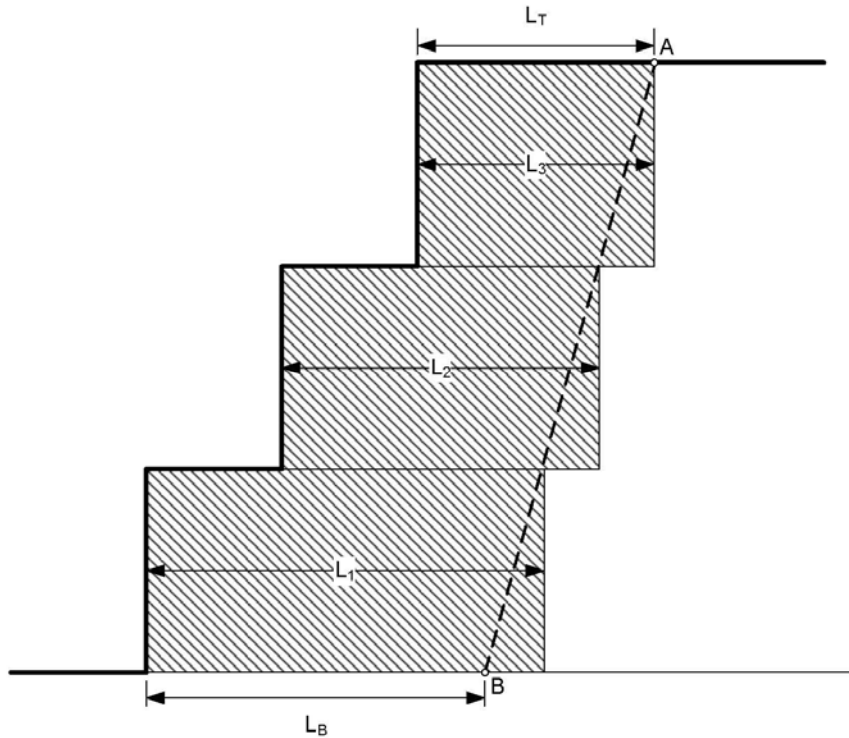

Figure 3.19 Determination of lengths of intermediate reinforcement for multi-tiered walls

To illustrate the procedure described above for determining reinforcement lengths, consider again the four-tier wall system shown previously in Figure 3.12. The required base length has already been shown to be approximately 25 feet. For the top length, Figure 3.18 reveals that a normalized top length, L_T/H_{total} of about 0.36 is required. This gives a required top length of approximately 10 feet ($= 0.36 \times 28$ feet). Using a base length of 25.2 feet and a top length of 10 feet, the broken line shown in Figure 3.20 is drawn. The required reinforcement lengths for each tier are then determined as indicated by the hatched regions in Figure 3.20.

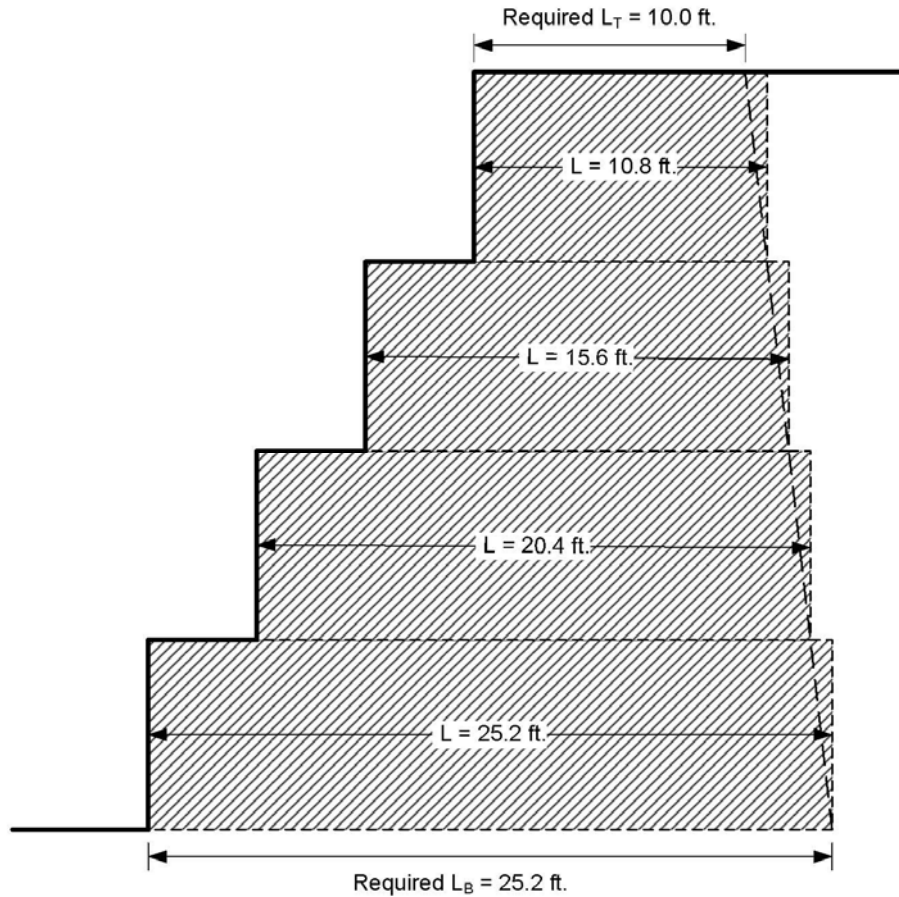

Figure 3.20 Determination of reinforcement length requirements for example four-tiered wall

Multi-Tiered Walls with Nonuniform Tiers

The procedures described in the previous sections are intended for simple multi-tiered walls in which the height and offset of the individual walls is the same. However, for wall systems in which the wall heights and/or offset distances vary, a similar procedure can be used. To determine the required reinforcement lengths, the following steps are performed:

1. Determination of Base Length

Slope stability computations are performed for the wall system using circular slip surfaces forced through selected points at the “heel” of the wall (See Figure 3.3). The slip surfaces are assumed to pass entirely outside the reinforced soil. Reinforcement can thus be excluded from the analyses. The horizontal position of the point is varied until the developed friction angle for the critical (lowest factor of safety) slip surface is approximately 20.6 degrees. Any friction angle can be assumed for the slope stability calculations. The developed friction angle is calculated from Eq. 3.1 using the assumed friction angle and computed factor of safety, and is independent of the assumed friction

angle. The horizontal position of the point yielding a developed friction angle of 20.6 degrees defines the required reinforcement length, L_B , at the base of the wall.

2. Determination of Top Length

A second series of slope stability computations is performed to locate the slip surface requiring the maximum reinforcement force for stability. To determine the required reinforcement force, any layout of reinforcement and forces can be assumed. It is best if the reinforcement is made very long such that the slip surface intersects all layers of reinforcement. Also it is recommended that the reinforcement be distributed to produce a linearly increasing resisting force over the height of the wall with uniform (constant) reinforcement spacing. A friction angle of 34 degrees (or other value if the soil is known to be stronger or weaker) should be assumed. The forces in the reinforcement should be adjusted (usually by trial and error) until the computed factor of safety for shear strength is one. The reinforcement forces then represent the required forces with the shear strength fully developed. The point where the critical slip surface intersects the top of the wall system defines the minimum required length, L_T , for reinforcement at the top of the wall.

3. Estimate Intermediate Reinforcement Lengths

Given the lengths L_B and L_T determined from the first two steps, the lengths of reinforcement for each tier are determined as described earlier and illustrated in Figure 3.19.

Summary and Discussion

The procedures presented in this chapter provide a means for estimating the required lengths of reinforcement for multi-tiered wall systems. The charts presented in Figures 3.11 and 3.18 provide a simple means for estimating the required lengths for walls with uniform height and offset distances. The charts assume competent foundations and retained soil that has no water and a friction angle of at least 30 degrees. The retained soil is assumed to have a friction angle of at least 34 degrees and also to be free of water. Procedures are also outlined for determining the required lengths through a systematic series of slope stability analyses for walls with more complex geometries including non-uniform wall heights and offsets.

The required lengths determined in the manner described here do not include the length required to develop the pullout resistance of the reinforcement. Separate calculations need to be made to determine the required embedment length to develop pullout resistance, and these lengths should be added to the lengths determined using the procedures described in this chapter. The required lengths for pullout can be calculated using the procedures described in the present FHWA guidelines, taking into account the beneficial effects of increased overburden when the wall is a multi-tiered wall. These procedures are discussed further in Chapter 6.

Once the reinforcement lengths are established and suitable reinforcement has been determined, slope stability analyses should be performed to verify that the reinforcement

lengths and resistances (forces) are adequate. If the factor of safety is found to be too low, either the lengths or the strength of the reinforcement will need to be increased.

Chapter 4 - Design Examples

Introduction

To illustrate the procedures and design charts presented in the previous chapters of this report, a series of hypothetical multi-tier walls was selected and design requirements were determined. Three different hypothetical wall systems were selected. For each system, the reinforcement force and length requirements were determined for each tier using the procedures outlined in Chapters 2 and 3, respectively. Once the reinforcement forces and lengths were determined, global stability analyses were conducted to compute a minimum factor of safety for each wall system.

Methodology - Definition of Factors of Safety

Current FHWA guidelines for wall design involves computing the minimum required reinforcement forces based on earth pressures. The earth pressures are generally based on active earth pressure conditions, which assume that the soil shear strength is fully developed, i.e., the factor of safety applied to soil shear strength is one. Reinforcement is then selected to provide an adequate factor of safety against failure of the reinforcement by rupture or pullout. In effect this procedure applies the factor of safety to the reinforcement forces, rather than to the shear strength of the soil. For the global stability analyses, which are performed subsequently, an additional factor of safety may be applied to soil shear strength; however, this is not clearly defined in the FHWA guidelines. The only factors of safety clearly defined in the FHWA guidelines are the factors of safety applied to the reinforcement forces.

In contrast to the FHWA procedures for design of walls, the design of reinforcement for most slopes is based on defining a factor of safety with respect to shear strength. For example, the design charts and procedures developed by Schmertmann et al. (1987) are based on use of a “developed” friction angle, ϕ_d . The developed friction angle has been discussed in Chapter 3 and is defined as follows,

$$\phi_d = \arctan\left(\frac{\tan \phi}{F}\right) \quad (\text{Eq. 4.1})$$

where F is the factor of safety applied to shear strength ($\tan \phi$). For reinforced slope design, the developed friction angle is computed first and then used to determine the required reinforcement forces. The required reinforcement forces represent the force required to produce a given factor of safety with respect to shear strength. The required reinforcement forces may or may not be multiplied by an additional factor of safety to obtain the design forces. However, regardless of whether the reinforcement forces are multiplied by an additional factor of safety, a factor of safety is always applied to the shear strength of the soil for design of reinforced slopes.

For the following examples, two different approaches are used. In the first approach, the factor of safety is based on the procedures employed in the current FHWA design procedure: The soil shear strength is assumed to be fully mobilized to calculate the reinforcement forces and a factor of safety is applied to the calculated reinforcement

forces to obtain design values. Once the design values are determined, global stability analyses are performed to evaluate overall stability. For the global stability analyses, conventional slope stability analysis procedures are used to compute a factor of safety defined with respect to soil shear strength. In the second approach, a factor of safety is applied first to the shear strength of the soil. The required reinforcement forces are then calculated using a developed (factored) friction angle, ϕ_d . Finally, the resulting forces are used to compute global stability and an overall factor of safety with respect to shear strength. Results of the global stability analyses using the reinforcement forces determined using the two approaches described are then compared and discussed.

Example Multi-Tiered Wall Systems

Three different multi-tiered wall geometries were selected for analysis. The first wall system is a two-tiered wall system with an offset of 75 percent of the individual wall heights and is shown in Figure 4.1. The second wall system consists of four tiers with offsets between tiers of 50 percent of the individual wall heights, as shown in Figure 4.2. The third wall system has six tiers with 100 percent offsets, i.e., the offsets are equal to the individual tier heights. The tiered wall system is shown in Figure 4.3. Each individual wall is 10 feet high and for simplicity, none of the walls are embedded below the ground surface. All soil was assumed to have a total unit weight of 120 lbs./cu. ft.. The reinforced soil was assumed to have a friction angle of 34 degrees. The retained and foundation soils were assumed to have friction angles of 30 degrees. No groundwater was assumed to be present.

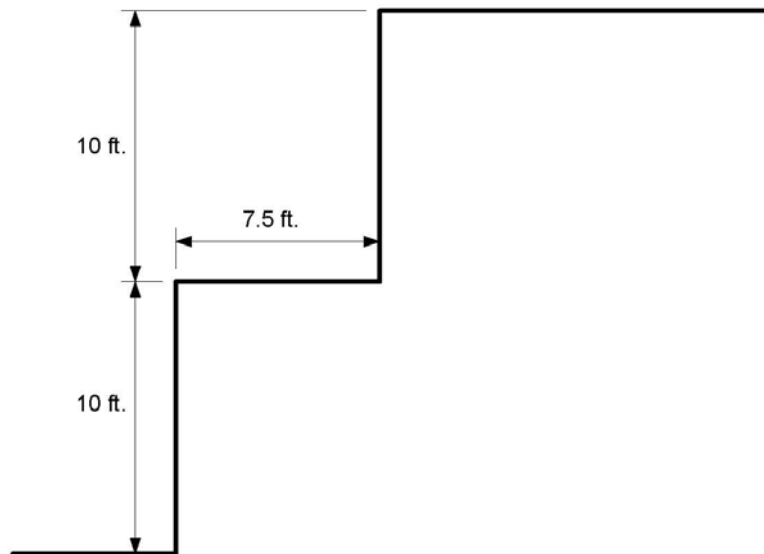

Figure 4.1 Example 1 — Two-tiered wall with 75 percent offset

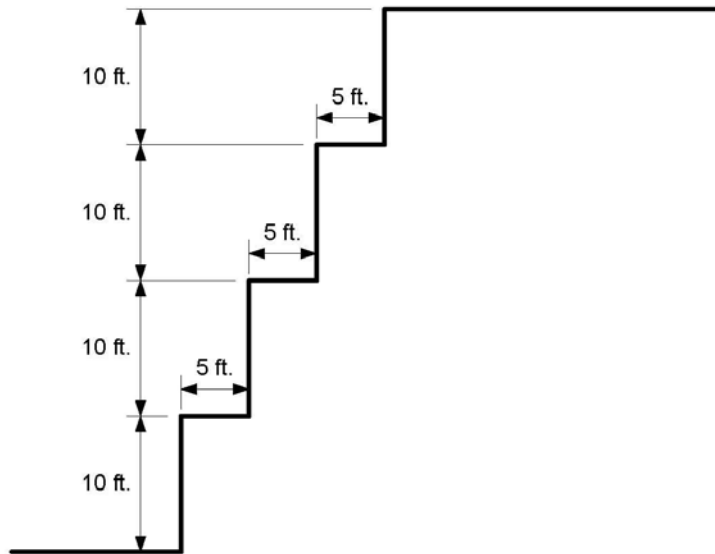

Figure 4.2 Example 2 — Four-tiered wall with 50 percent offsets

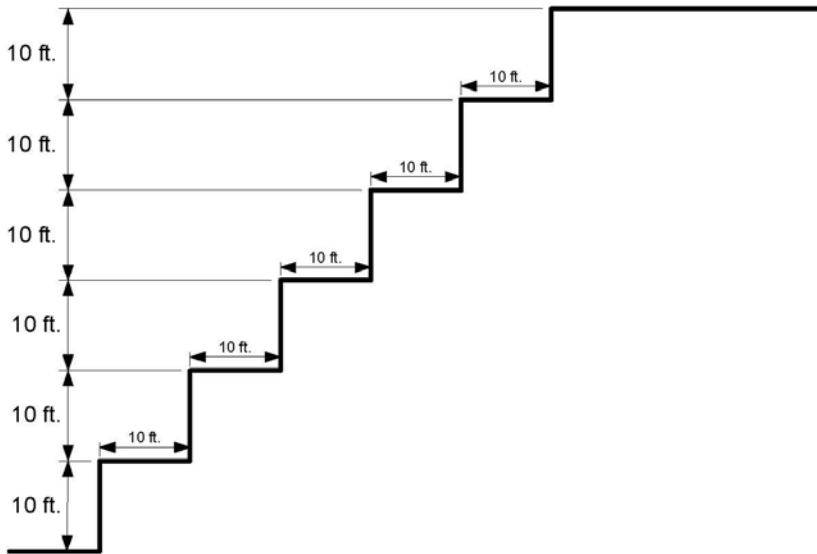

Figure 4.3 Example 3 — Six-tiered wall with 100 percent offsets

Example 1 - Two-Tier Wall

The first step in calculating the reinforcement requirement for the two-tier wall is to calculate the required force for the upper tier. The required force is calculated from the equation,

$$T_{\text{total}} = \frac{1}{2} K_T \gamma H_{\text{total}}^2 \quad (\text{Eq. 4.2})$$

For the single, upper tier alone H_{total} is the individual tier height, 10 feet. The total force coefficient, K_T , for a single tier and friction angle of 34 degrees is approximately 0.36. This gives a total force required for the upper tier of approximately 2160 pounds per lineal foot of wall.

Next, the required force is calculated for the first tier and the second tier combined. The required force is again calculated using Eq. 4.2. The total height, H_{total} , is now 20 feet (2 x 10 feet). The total force coefficient determined from the chart in Chapter 2 for a two-tier wall with 75 percent offset is approximately 0.15. This produces a total required force of approximately 3600 pounds. It has already been determined that 2160 pounds are required for the upper tier. Thus, an additional 1440 pounds is required for the second (lower) tier. However, it does not seem reasonable that a lower tier should have less reinforcement than an upper tier. Accordingly, it is recommended that when this occurs, the required reinforcement forces for the lower tier be the same as those for the upper tier. Thus, the lower tier is also assigned a required force of 2160 pounds.

The next step is to determine the required lengths of the reinforcement for the upper and lower tiers. From the charts presented in Chapter 3, the normalized top and bottom lengths, L_T/H_{total} and L_B/H_{total} , can be determined. The following values are determined from these charts,

$$\frac{L_T}{H_{total}} = 0.41 \quad (\text{Eq. 4.3})$$

and,

$$\frac{L_B}{H_{total}} = 0.86 \quad (\text{Eq. 4.4})$$

For a total wall system height, H_{total} , of 20 feet, and the normalized lengths shown above, the required top and bottom lengths are 8 and 17 feet, respectively. The required reinforcement forces and lengths are shown schematically in Figure 4.4.

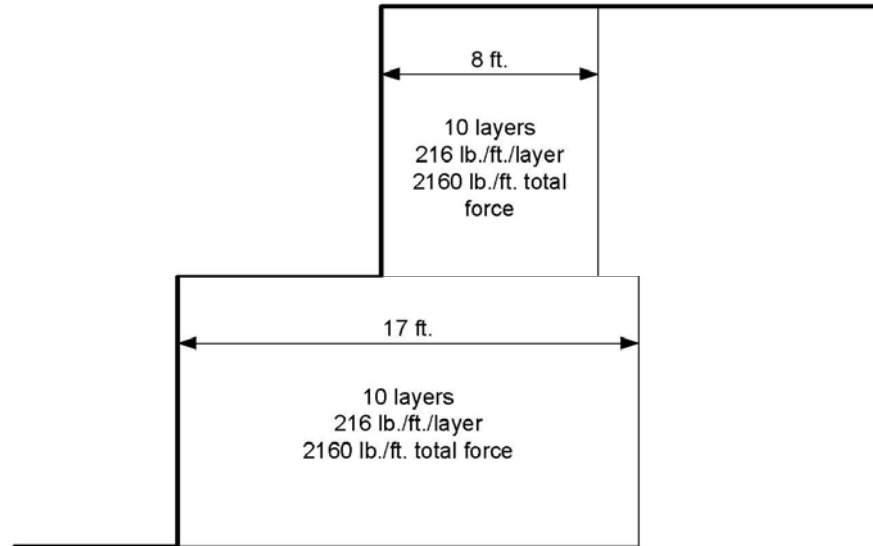

Figure 4.4 Required reinforcement forces and lengths for two-tiered wall system with 75 percent offset — Friction angle = 34 degrees

As a check on the forces and lengths determined, global stability computations were performed for the reinforcement layout determined above. In this case, the forces do not have any factor of safety applied. Recall also that the soil shear strength was assumed to be fully mobilized. Thus, no factor of safety is applied to the soil shear strength as well. The precise number of reinforcement layers and the resistance of each layer will depend on the type of reinforcement and may also depend on considerations of internal stability and pullout resistance. However, for global stability, the exact distribution of the reinforcement forces should not have a large effect on the factor of safety. For the current global stability analyses, the reinforcement forces were assumed to be provided by ten equally spaced layers of reinforcement with each layer providing the same resistance.

The critical slip surface found from the global stability analysis is shown in Figure 4.5. The minimum factor of safety for this slip surface is approximately 1.03. A factor of safety close to one is not surprising because the full shear strength was assumed to be mobilized, i.e., $F_{\text{strength}} = 1$, to calculate the reinforcement forces, and no factor of safety was applied once the reinforcement forces were calculated. Actually, the fact that the factor of safety is close to one is encouraging because when the reinforcement forces were calculated in Chapter 2, the reinforcement was assumed to be very long so that the slip surface intersected every layer. Also, when the required reinforcement lengths were determined in Chapter 3, the reinforcement was assumed to be strong enough to force the critical slip surface entirely outside the reinforced zone. Neither of these conditions exists for the critical slip surface shown in Figure 4.5. The slip surface intersects some, but only some of the reinforcement. The slip surface does not intersect all the reinforcement and does not pass entirely outside all the reinforcement. Thus, while the procedures and slip surfaces assumed for the analyses outlined in Chapters 2 and 3 are different from the global stability analyses and critical slip surface presented here, the

procedures used earlier seem to have produced reinforcement forces and lengths that are very reasonable.

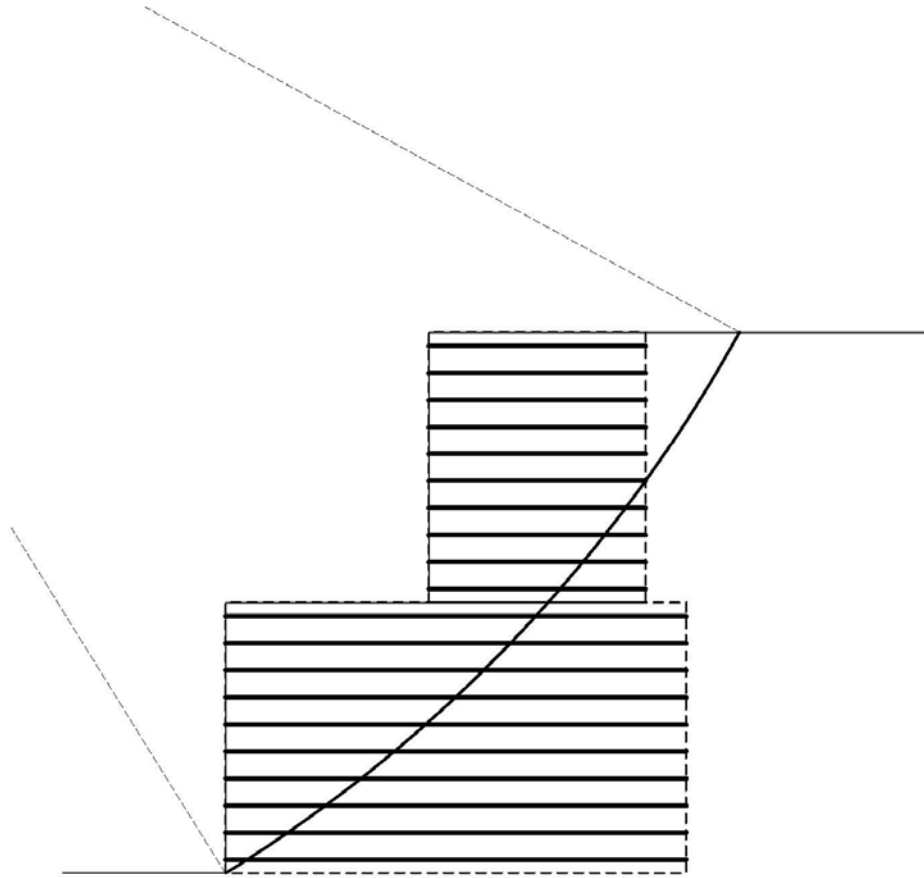

Figure 4.5 Example 1 — Critical slip surface for two-tiered wall system with 75 percent offset — Reinforcement based on developed friction angle = 34 degrees

For adequate global stability, it is necessary to apply some factor of safety to the computed reinforcement forces presented above. To illustrate how the factor of safety for global stability increases with the factor of safety applied to the reinforcement forces, additional analyses were performed where the reinforcement forces were multiplied by factors of safety of 1.5 and 3.0. That is, the reinforcement was assigned forces that provided resistance 1.5 and 3 times the minimum resistance required for stability with the soil shear strength fully developed. In all cases, the global factor of safety that was computed was computed using conventional slope stability analysis procedures where the factor of safety that is computed is applied to the soil shear strength only. With factors of safety of 1.5 and 3 applied to the reinforcement forces, the global factors of safety increased from 1.03 to 1.21 and 1.67, respectively. These analyses, as well as others that have been performed, show that in general to have a factor of safety of 1.5 for global stability, it is necessary to apply a factor of safety significantly greater than 1.5 to the required reinforcement forces. If the reinforcement forces are calculated using procedures like the FHWA procedures and those presented in Chapter 2, where the soil shear strength is assumed to be fully mobilized, it is necessary to apply a factor of safety greater than 1.5 to the forces if the global factor of safety for shear strength is to be 1.5.

For the above example, the required reinforcement forces were calculated assuming that the soil shear strength was fully developed, i.e., the developed and actual friction angles were the same (34 degrees). For comparison, a second set of calculations was performed where the friction angle was reduced by a factor of safety and the reduced friction angle was used to compute the required reinforcement forces. This is essentially the approach used for design of reinforced slopes. A friction angle of 24 degrees was used, which corresponds to a factor of safety for shear strength very close to 1.5 (actually $\tan 34^\circ \div \tan 24^\circ = 1.51$). The design calculations with this friction angle were performed as follows: First, the required force for the upper tier of the two-tier system was computed from Eq. 4.1. The total force coefficient, K_T , for a friction angle of 24 degrees is approximately 0.53. This gave a required force for the upper tier of 3180 pounds per lineal foot of wall. Next, the reinforcement force required for the first and second tiers combined was calculated. The total force coefficient, K_T , for a two-tiered wall system with 75 percent offset and a friction angle of 24 degrees is approximately 0.30. This gives a total required force of approximately 7200 pounds per lineal foot of wall for the two tiers combined. If the force assigned to the upper tier is 3180 pounds per lineal foot, the remaining force required for the lower tier is 4020 pounds per lineal foot of wall. In this case where a developed friction angle of 24 degrees was used, the force required for the lower tier is greater than the force required for the upper tier. This seems reasonable, but differs from what was found previously when a friction angle of 34 degrees was used. In general it was found for all the examples considered in this chapter that the force required for successively lower tiers was always as large or larger than the force required for upper tiers when a friction angle of 24 degrees was assumed. In contrast, when the friction angle was assumed to be 34 degrees, the required force computed for upper tiers often exceeded what was required for lower tiers—a condition that does not seem reasonable for most multi-tiered walls. In conclusion, it seems that computation of the required forces using a factored shear strength produces more rational results, although this is not what has been done historically for MSE wall design.

Global stability analyses were performed using the reinforcement forces computed with a friction angle of 24 degrees. Again, as for all other global stability computations, the factor of safety computed in these global stability analyses was applied to the soil shear strength. The critical slip surface yielding the minimum factor of safety is shown in Figure 4.6. The factor of safety for this slip surface is approximately 1.30. Although the reinforcement forces were computed using a factor of safety for shear strength of 1.5, the factor of safety for the global stability analysis is lower because a significant portion of the slip surface passes outside the reinforced soil mass. As discussed in Chapter 3, the lengths of the reinforcement in the upper portion of the wall system were established based on the “active” zone. For the analyses described above, this zone was located using an assumed friction angle of 34 degrees, which is considered a lower-bound value for the strength of the reinforced soil. If a developed friction angle of 24 degrees is used, the extent of the active zone will increase. For a friction angle of 24 degrees, the length of the active zone at the top of the wall, based on procedures like those described in Chapter 3, increases from approximately 8 feet (for a friction angle of 34 degrees) to approximately 11 feet. To determine the effect such an increase in length would have, the global factor of safety was recomputed with the length of the upper reinforcement increased to 11 feet. The reinforcement forces and lengths based on a friction angle of

24° are illustrated schematically in Figure 4.7. The global factor of safety computed for this reinforcement configuration is 1.42, which is noticeably closer to the value of 1.5 for the factor of safety that was used to compute the reinforcement forces.

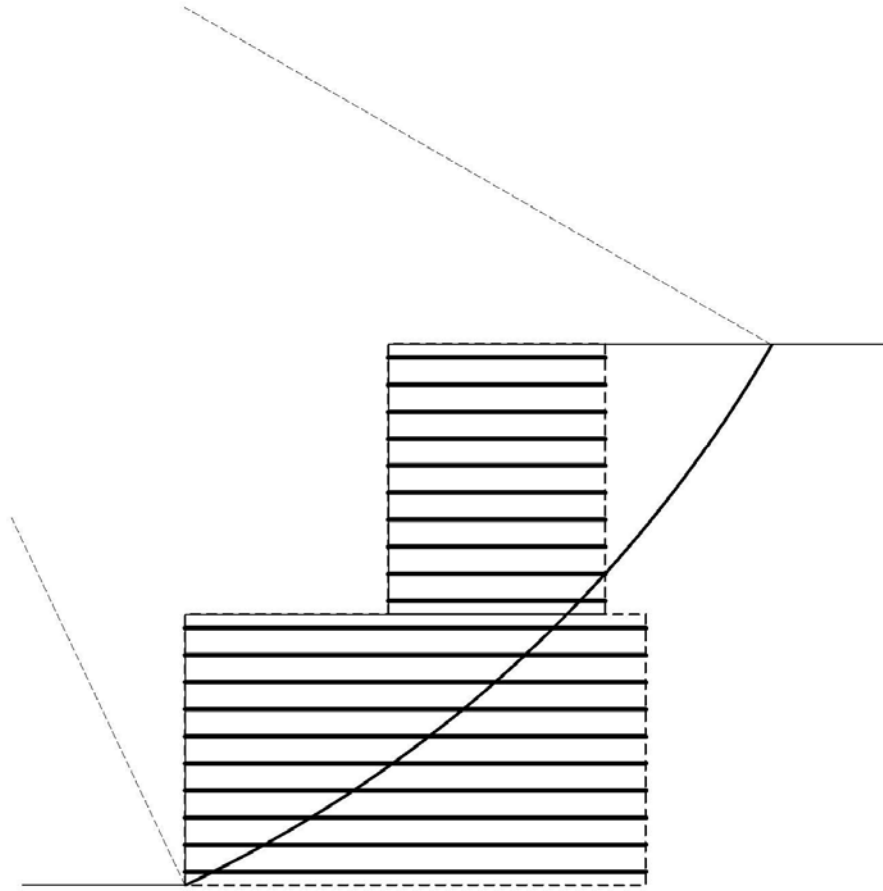

Figure 4.6 Example 1 — Critical slip surface for two-tiered wall system with 75 percent offset — Reinforcement forces based on developed friction angle = 24 degrees; reinforcement lengths based on active wedge for friction angle = 34 degrees

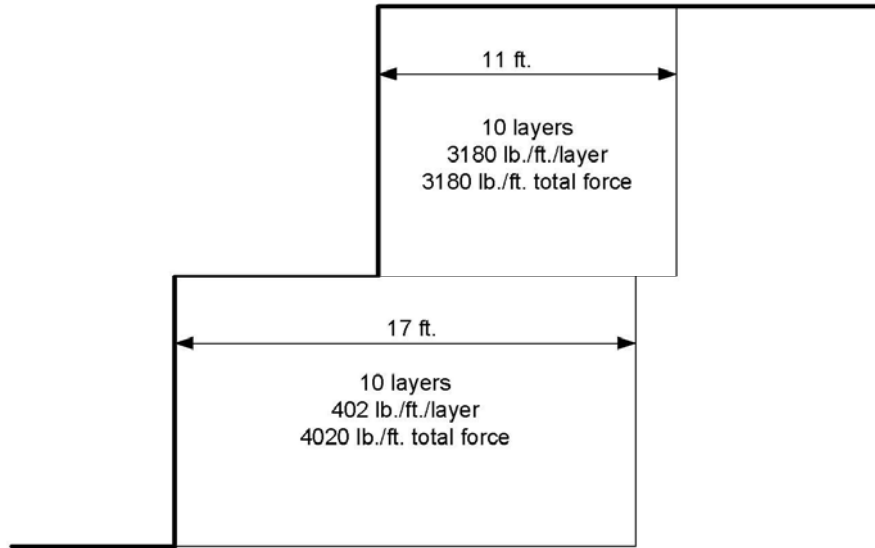

Figure 4.7 Example 1 — Required reinforcement forces and lengths for two-tiered wall system with 75 percent offset — Friction angle = 24 degrees

Example 2 - Four-Tier Wall

The second example chosen for design is a four-tier wall system with 75 percent offset. This wall system was shown earlier in Figure 4.2. Details of the calculations for reinforcement forces and lengths are presented in Appendix A. Global stability calculations were first performed using the required reinforcement forces that were computed assuming a friction angle of 34 degrees. The required reinforcement forces and lengths are shown schematically in Figure 4.8. Global stability computations were performed with no factor of safety applied to the reinforcement forces and with factors of safety of 1.5 and 3 applied. Results of these calculations are summarized in Table 4.1.

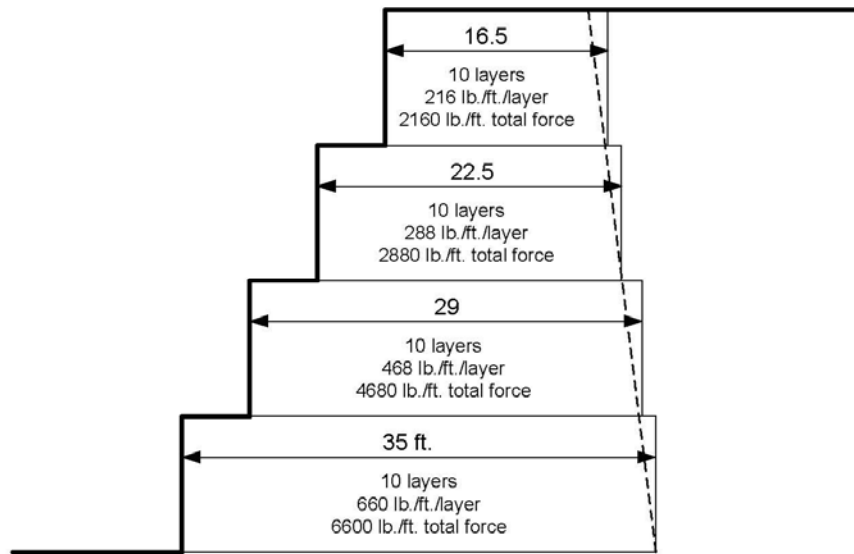

Figure 4.8 Example 2 — Required reinforcement forces and lengths for four-tiered wall system with 50 percent offset — Friction angle = 34 degrees

**Table 4.1 - Summary of global stability analyses for four-tiered wall -
Based on $\phi = 34$ degrees**

Factor of Safety Applied to Reinforcement Forces	Factor of Safety for Global Stability
1 (none applied)	1.07
1.5	1.35
3	1.55

The results in Table 4.1 again show that, as expected, the factor of safety for global stability is close to one when no factor of safety is applied to the reinforcement forces. Also, a factor of safety considerably greater than 1.5 must be applied to the reinforcement forces to achieve a factor of safety of 1.5 for global stability.

Reinforcement forces were also computed using a reduced friction angle of 24 degrees. These reinforcement forces are illustrated schematically in Figure 4.9. The lengths shown for the reinforcement are the same as those computed for a friction angle of 34 degrees. The computed factor of safety for global stability is approximately 1.51, which is essentially identical to the value that was assumed originally to compute the reinforcement forces, i.e., $\tan(34^\circ)/\tan(24^\circ) = 1.51$. However, for the original computation of forces, the critical slip surface intersected all the levels of reinforcement and the reinforcement forces were assumed to be the same for each tier, while in the global stability analysis of the actual design, the reinforcement forces increase downward

from tier-to-tier, and the critical slip surface passes outside most of the reinforced soil mass. The critical slip surface from the global stability analyses is shown in Figure 4.10.

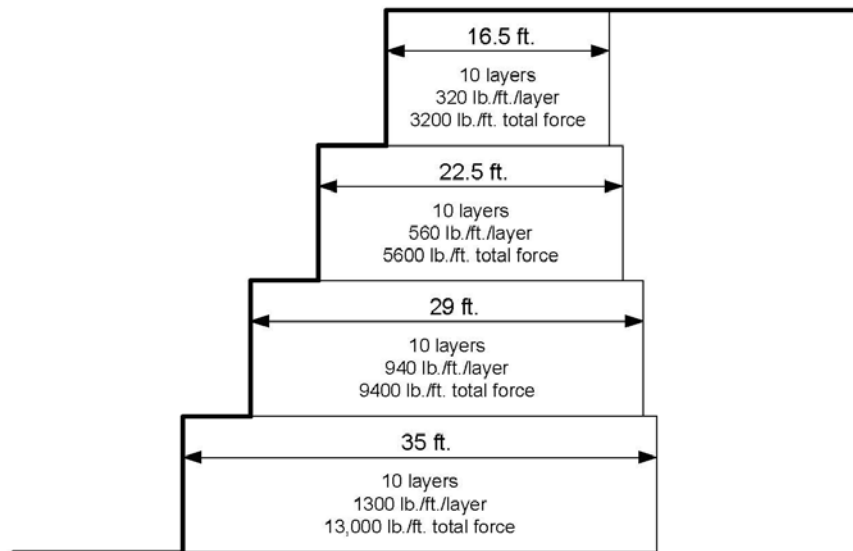

Figure 4.9 Example 2 — Required reinforcement forces and lengths for four-tiered wall system with 50 percent offset — Forces based on friction angle = 24 degrees; lengths based on friction angle = 34 degrees

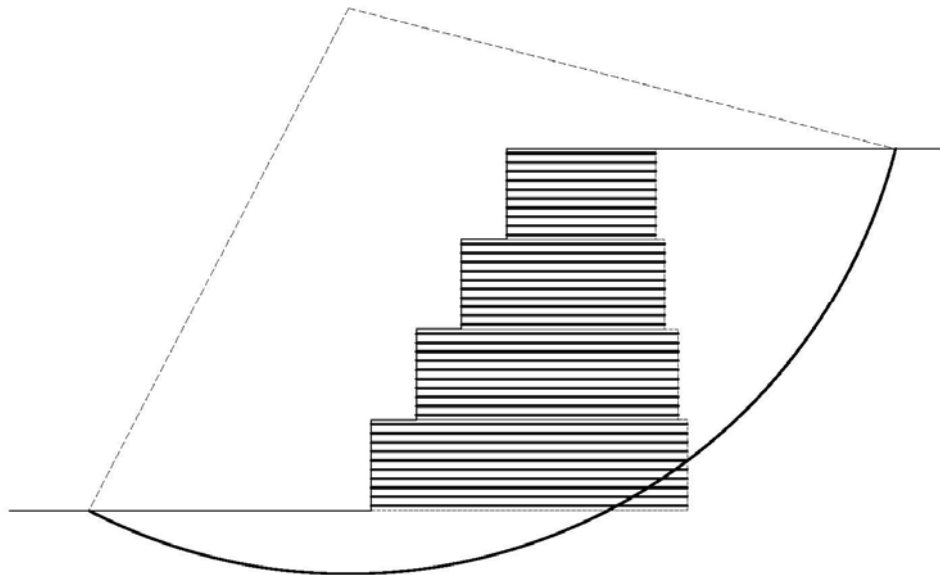

Figure 4.10 Example 2 — Critical slip surface for four-tiered wall system with 50 percent offset — Reinforcement forces based on friction angle = 24 degrees; reinforcement lengths based on friction angle = 34 degrees

Example 3 - Six-Tier Wall

The third example is a six-tier wall system with 100 percent offset. This wall system was shown in Figure 4.3. Details of the calculations for reinforcement forces and lengths are presented in Appendix A. As with the first example, the calculations of the required reinforcement force based on a developed friction angle of 34 degrees suggested that the reinforcement forces could be decreased in lower tiers compared to the tiers above. However, in selecting the design forces, each tier was assumed to require reinforcement forces at least as large as those of individual overlying tiers. The required reinforcement forces and lengths are shown schematically in Figure 4.11. Global stability calculations were performed using the required reinforcement forces shown in Figure 4.11 with no factor of safety applied to the reinforcement forces, as well as with factors of safety of 1.5 and 3 applied. Results of the calculations are summarized in Table 4.2.

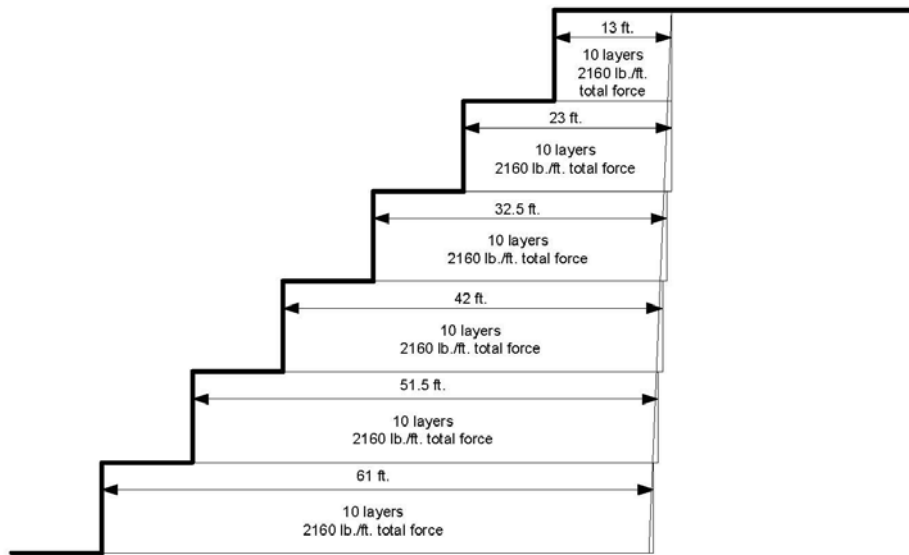

Figure 4.11 Example 3 — Required reinforcement forces and lengths for six-tiered wall system with 100 percent offset — Friction angle = 34 degrees

**Table 4.2 - Summary of global stability analyses for six-tiered wall -
Based on $\phi = 34$ degrees**

Factor of Safety Applied to Reinforcement Forces	Factor of Safety for Global Stability
1 (none applied)	1.00
1.5	1.10
3	1.32

As expected, the global factor of safety is close to one when no factor of safety is applied to the reinforcement forces. When a factor of safety is applied to the reinforcement forces, the global factor of safety (with respect to shear strength) is smaller than the factor of safety applied to reinforcement forces. Even when a factor of safety of 3 is applied to the reinforcement forces, the global factor of safety is less than 1.5.

Reinforcement forces were also calculated using a developed friction angle of 24 degrees. The reinforcement forces are shown schematically in Figure 4.12. The lengths are the same as those calculated previously with a friction angle of 34 degrees. The critical slip surface producing a minimum factor of safety is shown Figure 4.13. The

minimum factor of safety is approximately 1.44.

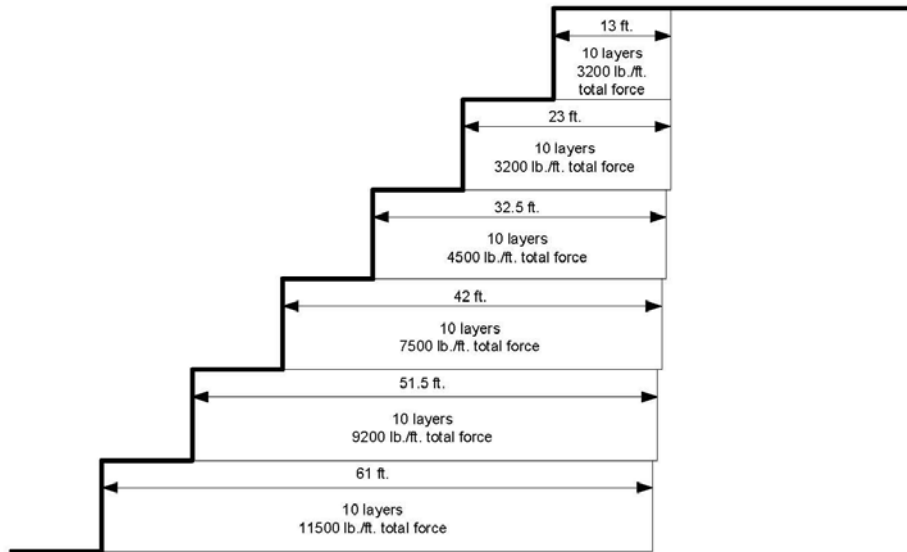

Figure 4.12 Example 3 — Required reinforcement forces and lengths for six-tiered wall system with 100 percent offset — Forces based on friction angle = 24 degrees; lengths based on friction angle = 34 degrees

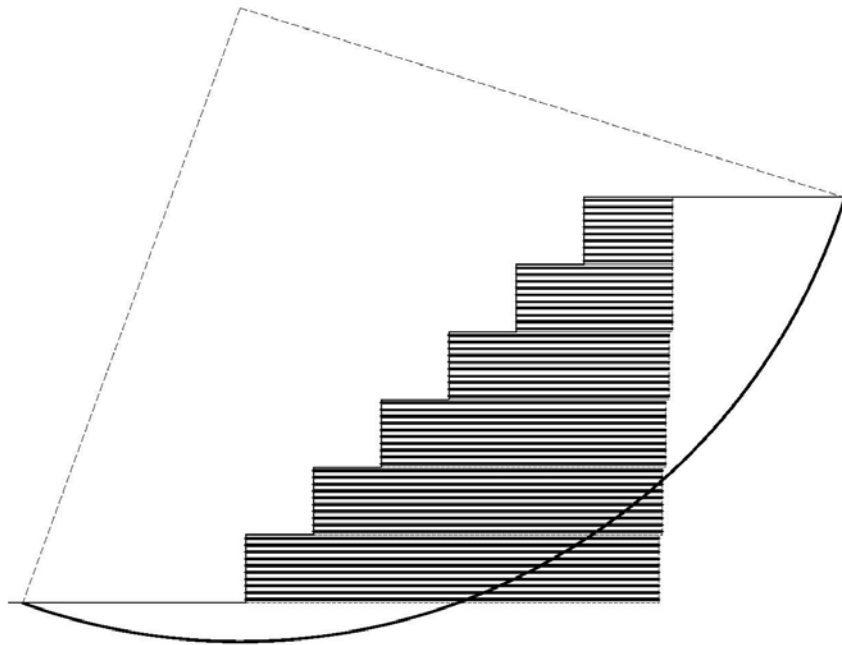

Figure 4.13 Example 3 — Critical slip surface for six-tiered wall system with 100 percent offset — Reinforcement forces based on friction angle = 24 degrees; reinforcement lengths based on friction angle = 34 degrees

Discussion

The three examples presented show that the reinforcement forces and lengths calculated using the procedures described in Chapter 2 and 3 produce global factors of safety close to unity. This is encouraging because the forces were calculated assuming that slip surfaces intersect every layer of reinforcement, while the lengths were calculated assuming the slip surface is forced to pass entirely outside the reinforcement. In actuality, the slip surface does neither. The critical slip surface for global stability intersects some, but not all of the reinforcement. Had the computed factors of safety been significantly less than one, it would suggest that the procedures outlined in Chapters 2 and 3 are not adequate for determining the reinforcement requirements.

In order to achieve a factor of safety greater than one for global stability, either of two approaches may be used. One approach is to compute the required forces assuming the soil shear strength is fully developed and then apply factors of safety to the forces required for stability. This is the approach followed by the FHWA guidelines and is similar to what is done for design of conventional, reinforced concrete retaining walls. The full soil strength is assumed to be developed to calculate an “active” earth pressure. The wall is then dimensioned to provide adequate overall stability. For MSE walls it appears that substantial factors of safety, sometimes exceeding 3, must be applied to the reinforcement forces to achieve a global factor of safety of 1.5. Also, based on the examples presented here, it appears that the value of the factors of safety that needs to be applied to the reinforcement forces to achieve a given factor of safety for global stability, e.g., 1.5, will vary widely depending on the particular wall geometry. No single value for the factor of safety can be recommended.

The second approach to design of reinforced walls is similar to the one used for design of reinforced slopes. In this approach a factor of safety is applied to the soil shear strength to compute a “developed” friction angle, and the developed friction angle is then used to compute the reinforcement requirements. The calculations presented in this chapter suggest that using a factor of safety of approximately 1.5 ($\tan 34^\circ \div \tan 24^\circ$) to compute the developed friction angle will produce global factors of safety of 1.4 or larger for most cases. It appears that selection of a factor of safety to compute the reinforcement forces for design is more straightforward if the factor of safety is applied to shear strength rather than to the reinforcement forces. This also seems logical because the factor of safety that is normally calculated in the analyses for global stability using a procedure of slices is a factor of safety applied to shear strength, not reinforcement forces.

Chapter 5 - TxDOT Design Examples

Introduction

In the previous chapter, analyses were presented for design of three hypothetical multi-tier wall systems using the procedures outlined in Chapters 2 and 3. In this chapter, additional analyses are presented for design of two multi-tier wall systems that are based on actual walls designed and built for TxDOT projects. The first wall is a four-tiered wall system constructed on U.S. 290 in Austin, Texas. The second wall system is a two-tier wall system at the Socorro Bridge on U.S. 375.

Both of the wall systems considered in this chapter consist of walls with varying heights and embedment depths among tiers. Neither wall system conforms to the uniform wall geometries considered in Chapters 2 and 3. Thus, additional analyses were required to calculate the required reinforcement forces and lengths for design. The calculations for determining the reinforcement requirements are presented in the following sections for each wall. Once the required reinforcement was determined, additional analyses were performed for each wall to determine the global stability. All analyses were performed using the UTEXAS4 software with the Simplified Bishop procedure of analysis.

TxDOT Wall Number 1 - U.S. 290, Austin

The first multi-tiered wall has four-tiers and a total height of approximately 29 feet, including 1-foot of embedment of the lower wall. Each tier is offset by 8 feet, and individual tiers range in height from approximately 6.3 to 11 feet, including the depths of embedment below ground. A uniform surcharge load of 250 psf is applied to the entire ground surface behind the uppermost wall. The wall system is shown to scale in Figure 5.1 and key dimensions are given in Table 5.1.

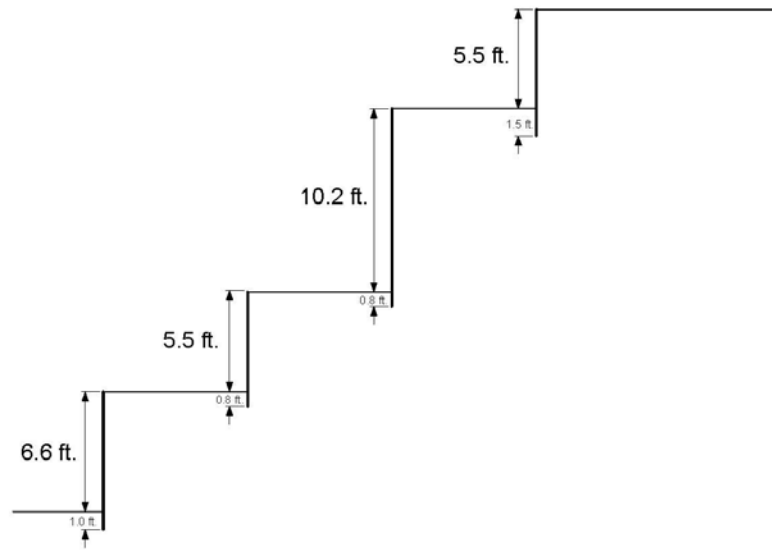

Figure 5.1 Wall geometry for US 290 wall, Austin, Texas

Table 5.1 - Summary of geometry for US 290 wall

Tier	Total Wall Height (ft.)	Embedment Depth (ft.)	Exposed Wall Height Above Ground (ft.)
4 (highest)	7.0	1.5	5.5
3	11.0	0.8	10.2
2	6.3	0.8	5.5
1 (lowest)	7.6	1.0	6.6

The required reinforcement forces were calculated assuming that the reinforced soil has a friction angle of 34 degrees and a total unit weight of 125 pcf. The required forces were calculated “top-down.” That is, the required force was calculated for the uppermost tier first, then for the two uppermost tiers, next for the three uppermost tiers, etc. The total reinforcement forces required for equilibrium are summarized in Table 5.2. The column labeled “Total Required Force” represents the force required for equilibrium of the current tier and all overlying tiers. For example, for Tier 2, the “Total Required Force” represents the force required for equilibrium of Tiers 2, 3, and 4.

**Table 5.2 - Summary of required force calculations for US 290 wall - ϕ
= 34 degrees**

Tier	Total Required Force - All Tiers (lbs./ft.)	Net Force Required ⁽¹⁾ (lbs./ft.)	Assigned “Design” Force (lbs./ft.)
4 (highest)	1531	1531	1530
3	3088	1558	2620 ⁽²⁾
2	2750	-1400	2620
1 (lowest)	3306	-3464	2620

⁽¹⁾ Total required force minus force assigned to overlying layers—except for Tier 3 (see Note 2).

⁽²⁾ Based on slip surface that is only within the third tier.

The values of “Total Required Force” shown in Table 5.2 were then used to establish the “design” values of the required forces for each tier. Values were again assigned in a “top-down” order. For each tier, the larger of the “net” force required and the force assigned to the overlying tier were taken as the required force for that tier, with the exception of Tier 3. Analyses for Tier 3 showed that a slip surface that was entirely within the third tier and did not pass through the overlying tier produced the highest required force (2620 pounds per foot).. Thus, the force assigned to Tier 3 was based on analyses of Tier 3 as an isolated tier. The “assigned” (design) values for the required forces are shown in Table 5.2.

To determine the length of the reinforcement in the bottom tier of the wall system, the procedure used in Chapter 3 was again used. The length required to produce a developed friction angle of 20.6 degrees for slip surfaces passing outside the base of a reinforced zone was found by trial and error. This produced a required base length of approximately 28.5 feet. To establish the length of the reinforcement at the top of the wall system, the extent of the “active zone” for the uppermost wall was determined. The active zone was defined by the slip surface producing the maximum required reinforcement force, assuming a linear increase in force with depth and a developed friction angle of 34 degrees. The critical slip surface corresponding to these conditions intersects the top of the multi-tiered wall system approximately 7 feet behind the face of the uppermost wall. Based on the length requirements of 7 and 28.5 feet for the reinforcement at the top and bottom of the wall system, respectively, the required lengths of reinforcement for each tier were determined as illustrated schematically in Figure 5.2.

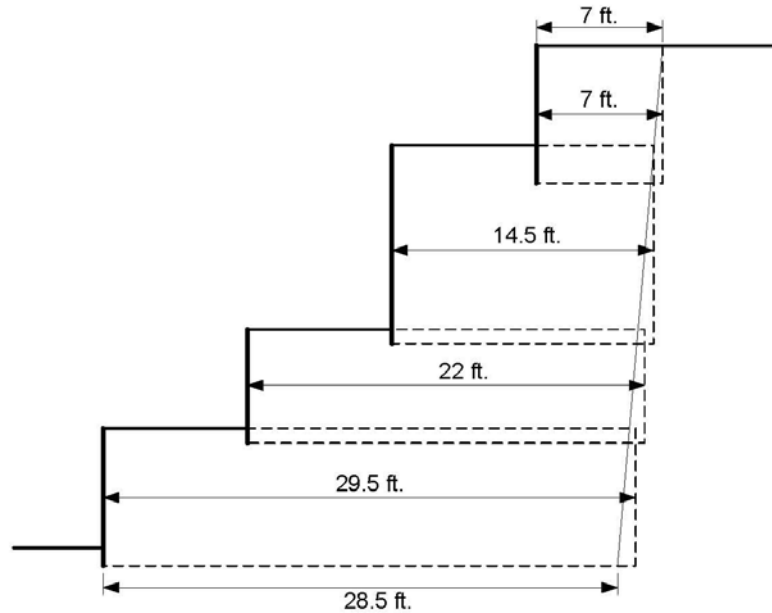

Figure 5.2 Required reinforcement lengths for US 290 wall system — Friction angle = 34 degrees

Once the required forces and lengths for reinforcement in each tier were determined, a series of global stability analyses was performed to compute the minimum factor of safety. The first series of analyses was performed using the “design” forces summarized in Table 5.2. The minimum factor of safety was approximately 1.40. Although the design forces were based on the strength being fully developed, i.e., a factor of safety for shear strength of one, the factor of safety computed from the global analyses was higher than one. The higher factor of safety exists because the reinforcement forces assigned to the lower two tiers of the wall system exceed the minimum required values and were based instead on the values for the overlying tier (see Table 5.2). The total reinforcement force assigned to the four tiers was 9390 pounds per lineal foot, while the analyses indicated a total force of only approximately 3300 pounds per lineal foot was sufficient for the overall four-tier wall system.

The global stability analyses were repeated by applying a factor of safety of 3 to the required reinforcement forces, i.e., the “design” forces in Table 5.2 were multiplied by 3. The minimum factor of safety in this case increased to approximately 1.54. As for all global stability analyses presented in this report, this global factor of safety corresponds to a factor of safety applied to soil shear strength.

Additional analyses were performed to calculate the required reinforcement forces for a developed friction angle of 24 degrees, which corresponds to a factor of safety of approximately 1.51 applied to shear strength. The same procedure that was used to determine the design forces in Table 5.2 with a friction angle of 34° were used to determine the design forces with a friction angle of 24°. The required reinforcement forces determined from these analyses were 2300 pounds per foot for the uppermost wall tier and 3930 pounds per lineal foot of wall for the three lower tiers. Global stability analyses using these forces produced a minimum factor of safety of approximately 1.47.

The reinforcement forces for each wall tier from the present analyses are summarized in Table 5.3. Also shown in this table are the long-term and long-term allowable design strengths from the original design prepared for TxDOT. For most tiers, the long-term allowable design strengths of the reinforcement in the original design meet or exceed the required forces calculated using a developed friction angle of 24 degrees, thus suggesting that the factors of safety for global stability will be at least 1.4. The largest differences between the original design values and those determined in this study are for the forces in the middle two wall tiers. The original design provides for forces in the higher Tier No. 3 (second tier from the top of the wall) to be larger than those in the underlying Tier No. 2. In the present study, the forces were selected so that lower tiers never had less total reinforcement force than the overlying tiers. This restriction may be inappropriate and require some adjustment when there are large contrasts in the height of individual tiers. If this restriction were to be relaxed, it is likely that the values selected in this study and those in the original design would be more similar.

Table 5.3 - Summary of required reinforcement forces for U.S. 290 wall

Tier	Reinforcement Forces for Tier – lbs./lineal ft. of wall				
	$\phi (= \phi_d) = 34^\circ$	$\phi (= \phi_d) = 34^\circ$ $F_{\text{reinforcement}} = 3$	$\phi_d = 24^\circ$	Long-Term Design Strength, T_{al}	Long-Term Allowable Design Strength, T_a
4 (top)	1530	4590	2300	5403	3602
3	2620	7860	3930	9252	6168
2	2620	7860	3930	4626	3084
1 (bottom)	2620	7860	3930	8943	5963
Total - All tiers	9390	28170	14090	28224	18817

The lengths of reinforcement in the individual wall tiers from the present study and for the original design are summarized in Table 5.4. The lengths employed in the original design range from being approximately 25 percent less (in Tier 3) to 14 percent more (in Tier 4). The largest difference in length is for Tier 3; where the original design lengths are approximately 25 percent lower than those in the present study. However, for this tier, the original design also provided significantly higher reinforcement strength. For example, the long-term allowable design strength for the reinforcement in Tier 3 is almost 6200 pounds per lineal foot of wall, while the reinforcement force suggested by this study⁴ is only 3930 pounds per lineal foot, or over 35 percent less than the original design value.

Table 5.4 - Summary of reinforcement lengths for U.S. 290 wall

Tier	Required Length of Reinforcement	
	This Study	Original Design
4 (top)	7	8
3	14.5	11
2	22	19.5
1 (bottom)	29.5	24

TxDOT Wall Number 2 - Socorro Bridge at US 375

The second multi-tiered wall has two tiers and a total height of approximately 18 feet, including approximately 1.3 feet of embedment of the lower wall. The two tiers are offset by approximately 9.84 feet and individual tiers are 12.3 and 7 feet high, including the depths of embedment of each tier below ground. The ground surface slopes at approximately 3 (horizontal):1 (vertical) behind the wall for a distance of approximately 29.5 feet from the face of the upper wall. A uniform vertical surcharge of 100 psf is

⁴ The “best” recommendation for reinforcement strength is believed to be the force calculated by applying a factor of safety of 1.5 to the soil shear strength.

applied to the ground surface behind the uppermost wall. The wall system is shown to scale in Figure 5.3 and key dimensions are given in Table 5.5.

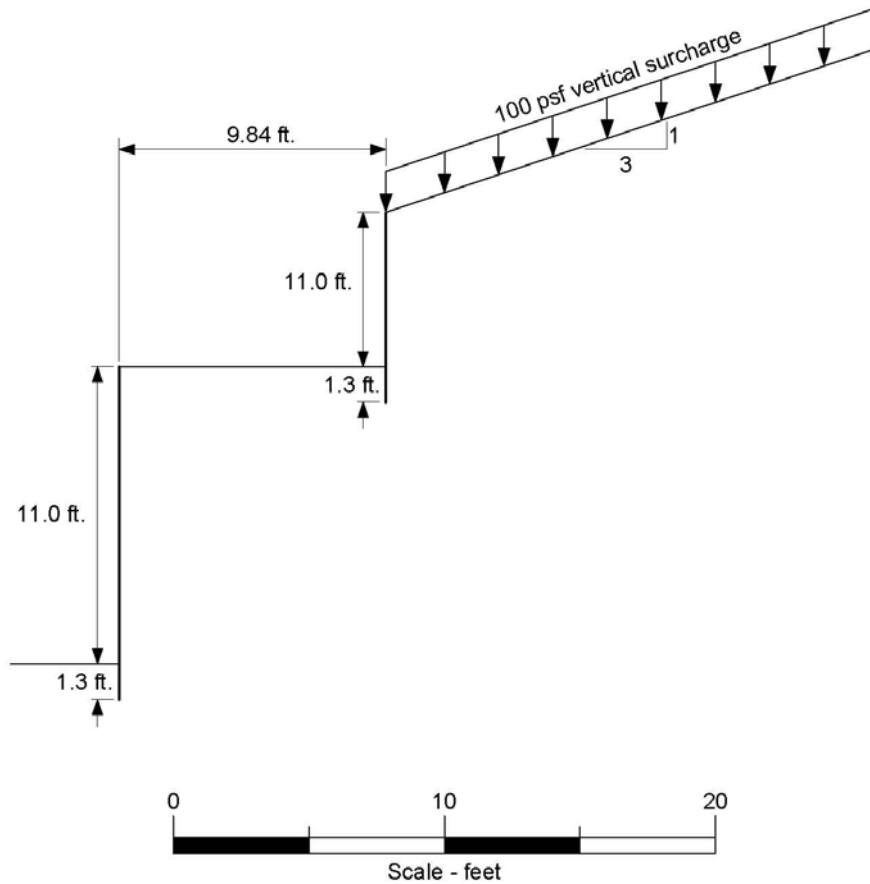

Figure 5.3 Geometry of wall system located near Socorro Bridge at US 375

Table 5.5 - Summary of geometry for wall near Socorro Bridge at U.S. 375

Tier	Total Wall Height (ft.)	Embedment Depth (ft.)	Exposed Wall Height Above Ground (ft.)
2 (highest)	7.0	1.3	5.7
1 (lowest)	12.3	1.3	11.0

Required reinforcement forces were calculated assuming for the reinforced soil a friction angle of 34 degrees and a total unit weight of 125 pcf. The required forces were calculated “top-down” in the manner described previously. However, the required forces for the lower tier were controlled by slip surfaces entirely within the lower tier and were not affected by the upper tier. The “design” values for the required forces are shown in Table 5.6.

Table 5.6 - Summary of required reinforcement forces for Socorro Bridge and U.S. 375 wall

Tier	Assigned, "Design" Force (lbs./ft.)
2 (highest)	1340
1 (lowest)	3440

The required lengths for the reinforcement were calculated in the same manner as for the previous example. The bottom length required to produce a developed friction angle of 20.6 degrees for slip surfaces passing outside the base of a reinforced zone was found to be approximately 24 feet. The required length of the reinforcement at the top of the wall was found by determining the extent of the "active" zone. The slip surface for the active zone intersected the sloping backfill surface a horizontal distance of approximately 8 feet behind the face of the upper wall. Based on the top and bottom length requirements, the required lengths of reinforcement for each tier were determined as illustrated schematically in Figure 5.4.

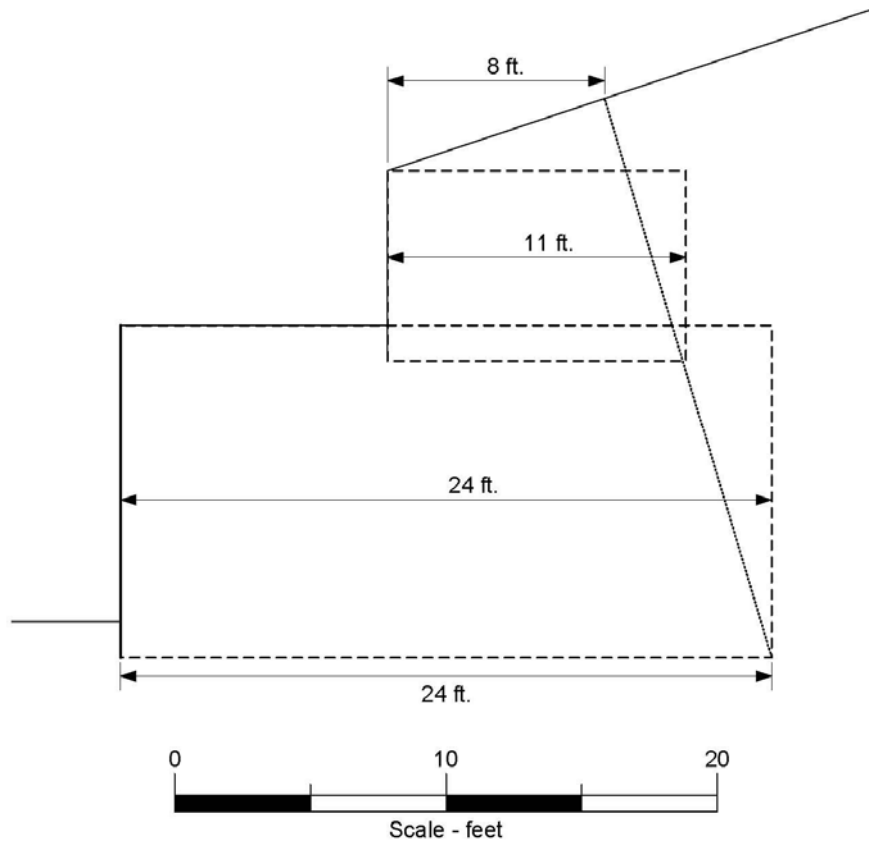

Figure 5.4 Required reinforcement lengths for wall system located near Socorro Bridge at US 375 — Friction angle = 34 degrees

Global stability analyses were performed using the required reinforcement forces and lengths summarized in Table 5.6 and Figure 5.4, respectively. Analyses were performed using the computed forces based both on the soil shear strength being fully developed and

with a factor of safety of 3 applied to the soil strength. With no factor of safety applied to the reinforcement forces, the global factor of safety was approximately 1.0, which is expected. With a factor of safety of 3 applied to increase the reinforcement forces, the global factor of safety (applied to shear strength) increased to approximately 1.54.

Additional analyses were performed to calculate the required reinforcement forces for a developed friction angle of 24 degrees (corresponding to a factor of safety of approximately 1.51 applied to shear strength). The required reinforcement forces determined from these analyses were 2170 pounds per foot for the upper wall tier and 4970 pounds per lineal foot of wall for the lower tier. Global stability analyses using these forces produced a minimum factor of safety of approximately 1.47.

The reinforcement forces for each wall tier from the present analyses are summarized in Table 5.7 along with long-term and long-term allowable design strengths from the original design prepared for TxDOT. The long-term allowable design strengths, T_a , of the reinforcement for the original design are approximately 1.8–2.0 times the required forces calculated using a developed friction angle of 24 degrees, i.e., by applying a factor of safety of approximately 1.5 to soil shear strength. However, while the original design forces appear to be significantly higher than the ones suggested by this study, the lengths of the reinforcement in the bottom tier for the original design are significantly less than the lengths determined in the present study. The reinforcement lengths determined in this study and for the original design are summarized in Table 5.8. The lengths are similar for the upper tier; however, for the lower tier the lengths determined in the present study are approximately 75 percent greater. Thus, lengths and forces in the reinforcement determined in this study are significantly different from those in the original design. The differences in force are probably offset to some degree by the differences in lengths, but because of these differences, it is difficult to compare the two sets of design values. It seems reasonable to expect that both are acceptable while at the same time being quite different.

Table 5.7 - Summary of required reinforcement forces for Socorro Bridge and U.S. 375 wall

Tier	Reinforcement Forces for Tier - lbs./lineal ft. of wall				
	$\phi (= \phi_d) = 34^\circ$	$\phi (= \phi_d) = 34^\circ$ $F_{\text{reinforcement}} = 3$	$\phi_d = 24^\circ$	Long-Term Design Strength, T_{al}	Long-Term Allowable Design Strength, T_a
2 (top)	1340	4020	2170	5898	3932
1 (bottom)	3440	10320	4970	14578	9719

Table 5.8 - Summary of reinforcement lengths for Socorro Bridge and U.S. 375 walls

Tier	Required Length of Reinforcement	
	This Study	Original Design
2 (top)	11	13.65
1 (bottom)	24	13.65

Chapter 6 - Internal Stability and Pullout Resistance

Introduction

The procedures presented in the previous chapters have focused on the “external” and global stability of MSE walls. However, all the slip surfaces in the analyses that were performed to compute the required forces in Chapter 2 and many of the slip surfaces for the global stability analyses presented in Chapters 4 and 5 passed through at least some of the soil reinforcement layers. In such cases, the capability of *individual* reinforcement layers to resist the internal forces was not evaluated. Instead, each layer of reinforcement was assumed to be capable of providing the designated or assumed tensile capacity. The lengths of reinforcement that are discussed in Chapters 3, 4, and 5 are assumed to be the lengths over which the reinforcement can develop its full tensile capacity. These lengths need to be increased by the amount needed to develop safely a pullout resistance equal to the design tensile strength of the reinforcement.

Evaluation of the additional length required for individual layers of reinforcement to develop the necessary pullout resistance requires calculating the internal stresses at each level of reinforcement. Currently, relatively little is known about the actual internal stresses in multi-tiered MSE walls. Until significant knowledge, including measured values of the internal forces and stresses in the reinforcement, can be developed, reliance must be placed largely on what is known and has been successfully used for single-tiered walls, tempered with conservative extensions to account for multiple wall tiers. For single-tiered walls, the evaluation of pullout resistance is based on estimating the vertical stresses. The vertical stresses are then used to calculate the unit pullout resistance from the following equation:

$$p_r = C \cdot F^* \cdot \sigma'_v \cdot \alpha \quad (\text{Eq. 6.1})$$

where p_r is the pullout resistance per unit length of reinforcement, C is the “effective unit perimeter of the reinforcement” (= 2 for strip, grid, and sheet reinforcement), F^* is a “pullout resistance factor,” σ'_v is the effective vertical stress, and α is a scale correction factor. The variables C , F^* , and α are discussed in detail in the current FHWA design guidelines (Elias et al., 2001). It is believed that a similar approach to the one represented by Eq. 6.1 can be used for multi-tiered walls. The primary difference between single-tiered and multi-tiered walls is in the calculation of the vertical stress, σ'_v . The balance of this chapter will focus primarily on the issue of vertical stresses for multi-tiered walls.

FHWA Guidelines for Two-Tier Walls

The current FHWA guidelines present procedures for calculating the vertical stresses for two-tier walls. The procedures used to calculate the vertical stresses depend on the offset (D) of the two walls relative to the heights of the walls. Walls are considered to have “large” horizontal offsets (D) when the following criterion is met:

$$D > H \tan(90 - \phi_r) \quad (\text{Eq. 6.2})$$

where H is the height of the lower wall and ϕ_r is the friction angle for the reinforced soil backfill. In this case, the walls are considered to act as two independent walls and the upper wall is not considered to contribute to the vertical stresses in the lower wall. Walls are considered to have “small” offsets when the following criterion is met:

$$D \leq \frac{H_{\text{total}}}{20} \quad (\text{Eq. 6.3})$$

where H_{total} is the combined height of the upper and lower walls. In this case, the walls are treated as one single wall with the full stress of the overlying wall contributing to the vertical stresses of the lower wall. For walls having intermediate offsets between the limits defined above, the additional vertical stresses behind the lower wall due to the overlying wall are calculated according to empirical criteria illustrated in Figure 6.1. Depending on the depth below the top of the lower wall and the distance behind the wall, the additional vertical stresses produced by the upper wall vary from zero to the full overburden stress.

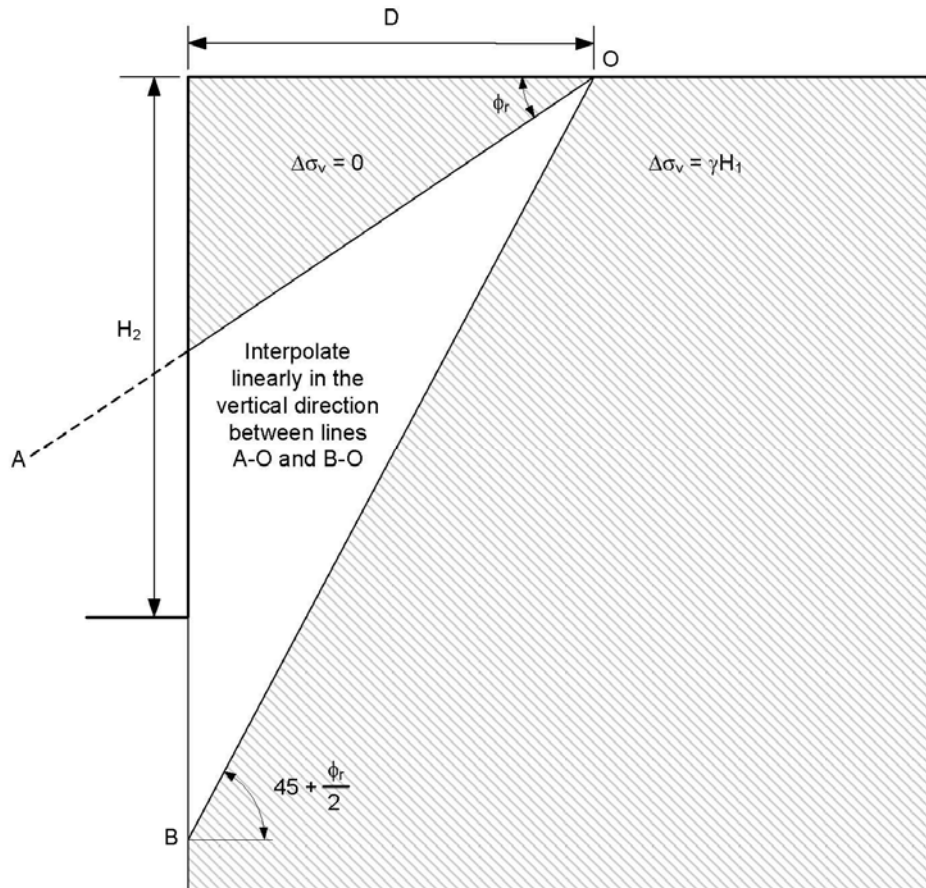
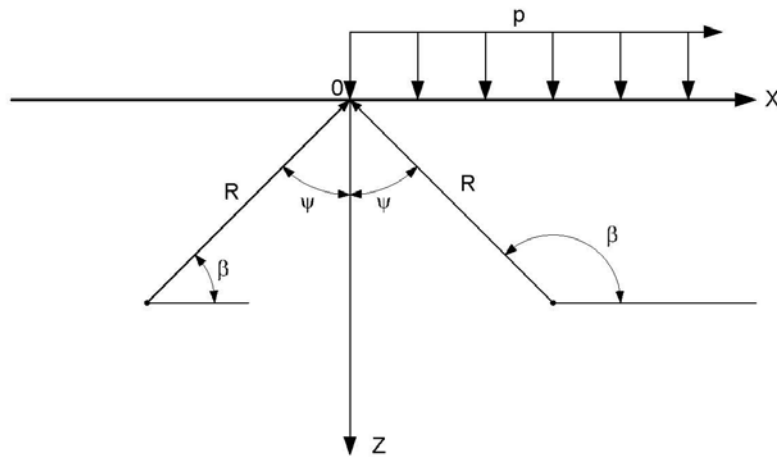

Figure 6.1 FHWA criteria for vertical stress increase behind tiered walls with “intermediate” horizontal offsets

Elastic Stress Distributions

As an alternative to the FHWA empirical procedure for calculating the additional vertical stress produced by a superimposed wall, the stress can be estimated using a solution based on the distribution of stresses beneath an elastic half-space. Gray (1936) presented the solution for the stresses in an elastic half-space subjected to a uniform loading over half the surface. Gray's solution is illustrated in Figure 6.2. Although this solution applies to a half-space, rather than a space with a vertical boundary, e.g., a wall, the solution can be used to estimate the stresses for a wall using the principle of superposition. By superimposing two identical uniform surcharges separated by a distance $2D$ (Figure 6.3a), the stresses corresponding to a perfectly rigid wall (Figure 6.3b) can be calculated. This solution corresponds to a perfectly smooth (no shear stress) wall face with zero horizontal displacement at the face of the wall. Alternatively, two uniform vertical surcharges with equal magnitudes but opposing directions can be imposed as shown in Figure 6.4a. The stresses in this case correspond to a "free" wall face, i.e., the surcharge produces no increase in horizontal stress at the "wall" face and the wall can deform horizontally as needed to satisfy this condition. In this case, the solution corresponds to a perfectly rough wall, i.e., the vertical displacements at the wall face due to the surcharge are zero.



$$\sigma_z = \frac{p}{\pi} \left(\beta + \frac{xz}{R^2} \right)$$

Figure 6.2 Grey's solution for the increase in vertical stress due to a uniform load over half the surface of a semi-infinite elastic half-space

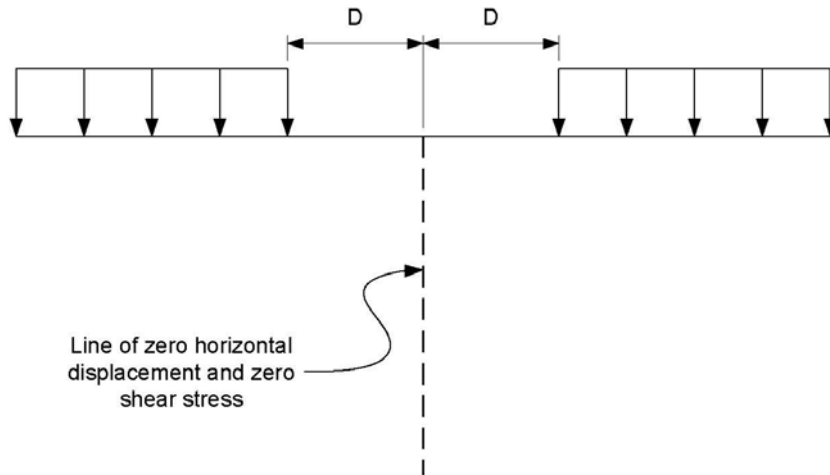

(a) Equivalent superimposed stresses.

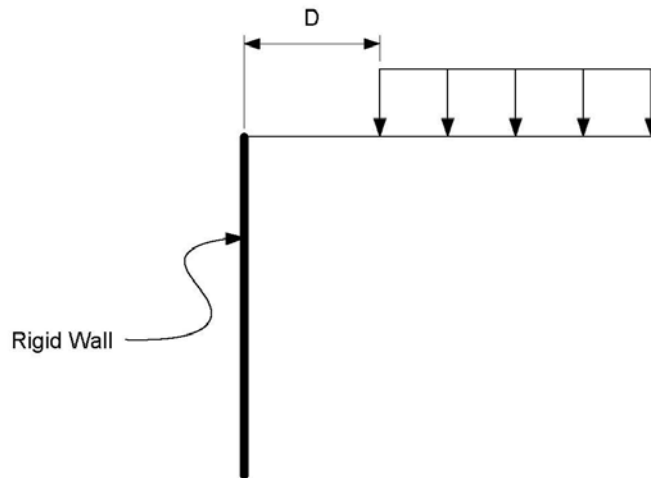

(b) Surcharge behind a rigid wall

Figure 6.3 Equivalent superimposed stresses used to represent the stresses produced by a vertical surcharge behind a "rigid" wall

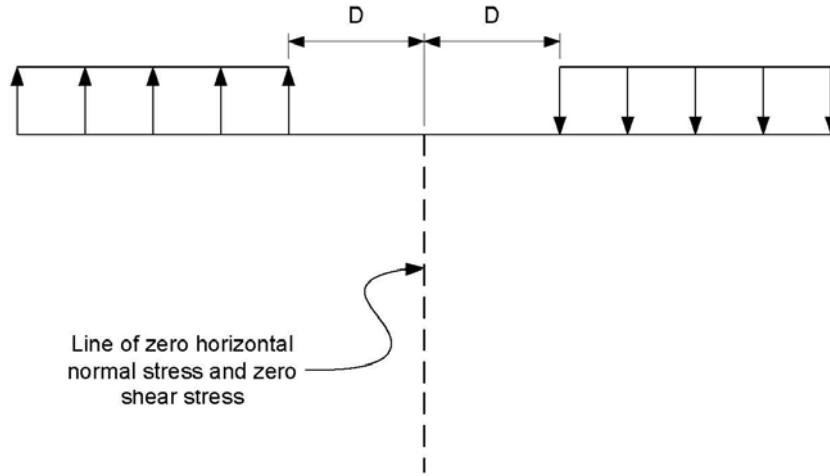

(a) Equivalent superimposed stresses.

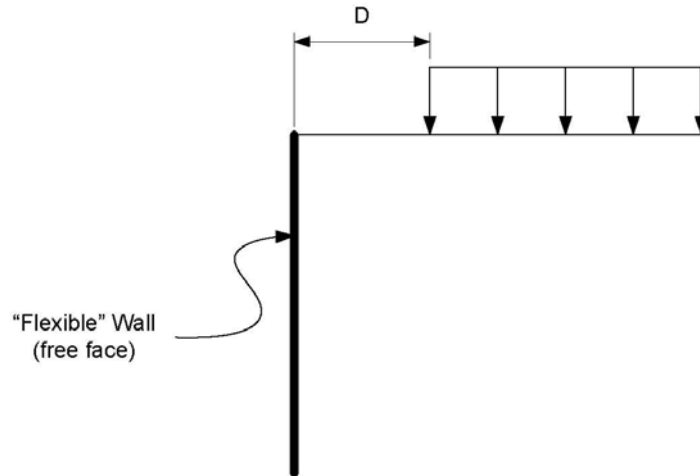

(b) Surcharge behind a "flexible" (free face) wall

Figure 6.4 Equivalent superimposed stresses used to represent the stresses produced by a vertical surcharge behind a "flexible" wall

Superposition of uniform surcharges as shown in Figures 6.3a and 6.4a leads to the following expression for the increase in vertical stress due to surcharge loading:

$$\Delta\sigma_z = \frac{q}{\pi} \left[\left(\beta^a + \frac{(x-D)z}{(R^a)^2} \right) + \kappa \left(\beta^i + \frac{(-x-D)z}{(R^i)^2} \right) \right] \quad (\text{Eq. 6.4})$$

where,

$$\beta^i = \arctan\left(\frac{z}{D+x}\right) \quad (\text{Eq. 6.5})$$

$$\beta^a = \arctan\left(\frac{z}{D-x}\right) \quad (\text{Eq. 6.6})$$

$$R^i = \sqrt{z^2 + (D+x)^2} \quad (\text{Eq. 6.7})$$

$$R^a = \sqrt{z^2 + (D-x)^2} \quad (\text{Eq. 6.8})$$

Also, in the above equations, z is the depth below the surcharge (top of lower “wall”) and x is the distance from the “wall” face. It should be noted that in Gray’s original equations shown in Figure 6.2, x is measured from the edge of the surcharge, rather than from the “wall.” The quantity “ κ ” in Equation 6.4 is either +1 or -1 depending on the assumed conditions for the “wall” face. For a rigid wall (Figure 6.3) κ is +1, and for a “flexible” wall (Figure 6.4) κ is -1.

Comparison of Elastic and FHWA Suggested Stress Distributions

To examine the potential differences between the FHWA empirical guidelines and the elastic stress distribution, the increases in vertical stress were computed for the two-tier wall system shown in Figure 6.5. The upper wall is offset 10 feet horizontally from the face of the lower wall. The upper wall produces an equivalent surcharge of 2500 psf (20 feet x 125 lbs/cu.ft.). Increases in vertical stress were computed for depths of 5, 10, 15, and 20 feet below the top of the lower wall. The most important variable in this comparison is the offset relative to the depth where the stresses are computed. The depths (5, 10, 15, and 20 feet) correspond to 0.5, 1.0, 1.5, and 2.0 times the offset distance.

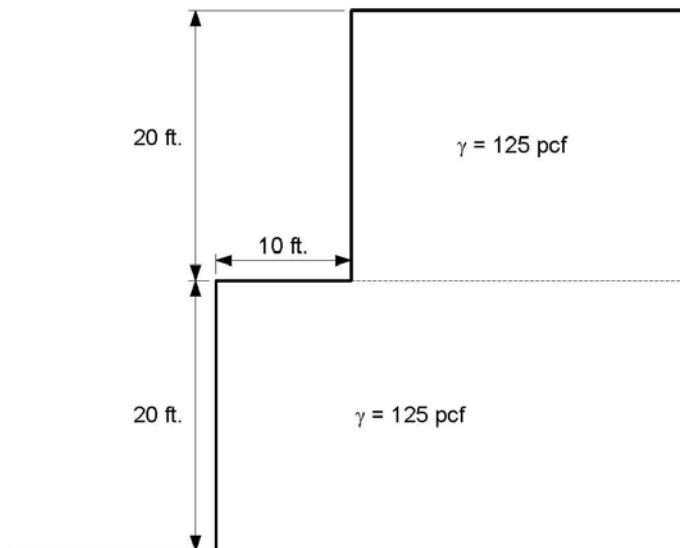

Figure 6.5 Two-tier wall system used for vertical stress calculations

The increases in vertical stress calculated from the elastic solutions for a “rigid” wall (Figure 6.3) and a “flexible” wall (Figure 6.4) are plotted in Figure 6.6. The stresses shown for the “flexible” wall are less than those for the rigid wall. At the wall face, the increase in stress for the flexible wall is zero, while for the rigid wall, the increase in stress is significantly higher. As the distance behind the wall approaches the depth below the surcharge, i.e., $x = z$, the stresses for both the flexible and rigid walls approach each other and become close to the stress produced by the surcharge.

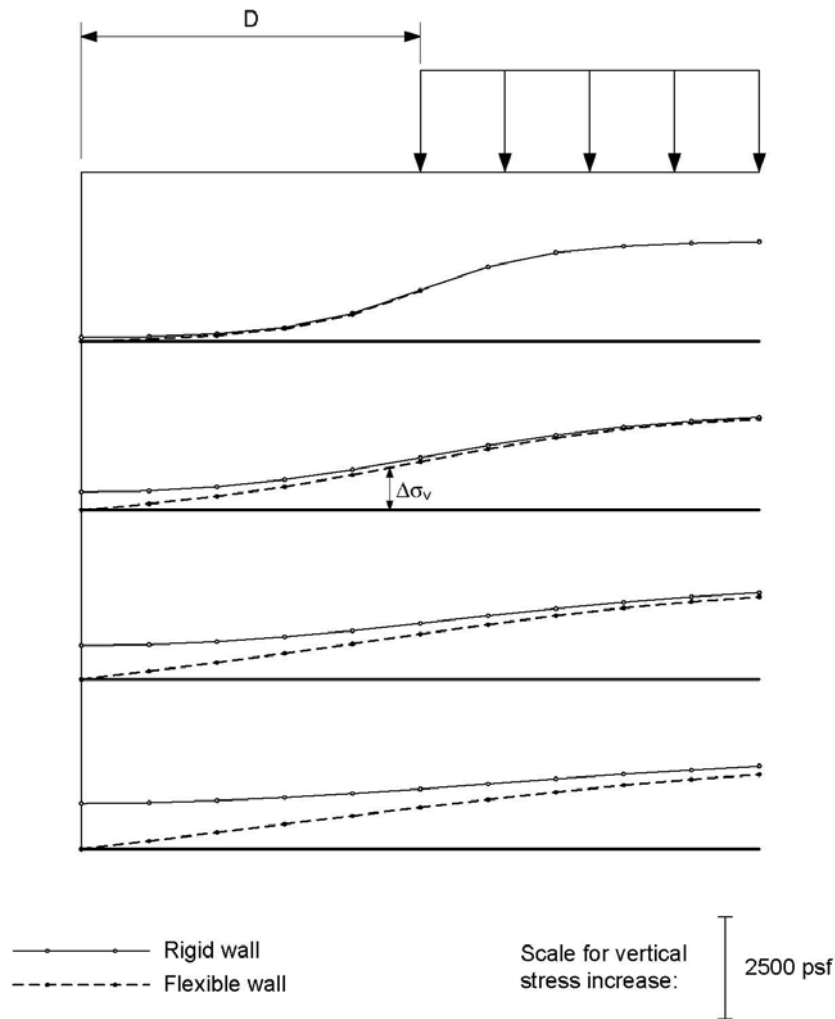

Figure 6.6 Comparison of increases in vertical stress behind a “rigid” and “flexible” wall calculated from elastic solution at depths of 0.5, 1.0, 1.5, and 2.0 times the horizontal offset (D)

In Figure 6.7, the increases in stress calculated from the elastic solution for a rigid wall and from the FHWA criteria (Figure 6.1) are plotted for comparison. It can be seen that for distances behind the wall that are less than or equal to the depth below the surcharge, i.e., $x = z$, the FHWA criteria result in substantially higher increases in vertical stress than the elastic solution.

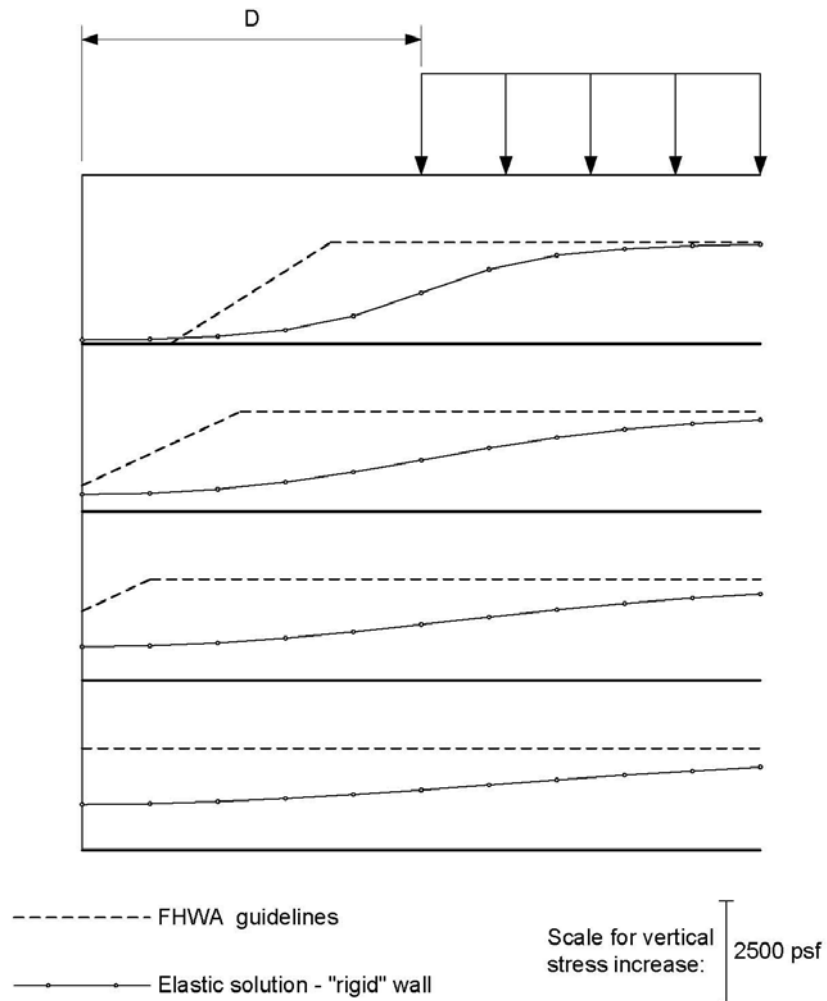

Figure 6.7 Comparison of increases in vertical stress behind a wall calculated using FHWA guidelines for a two-tier wall and using the elastic solution for a “rigid” wall at depths of 0.5, 1.0, 1.5, and 2.0 times the horizontal offset (D)

Discussion

The current FHWA criteria for calculating the vertical stress increase caused by an overlying wall tier apparently overestimate the increase in vertical stress. Thus, the criteria will lead to an overestimate of the pullout resistance computed from Eq. 6.1, i.e., the criteria are “unconservative.” However, the FHWA criteria are also used in the FHWA design guidelines as a basis for estimating the effects of additional vertical stresses on the horizontal stresses (force) in the reinforcement. An overestimate of the horizontal stress represents a “conservative” estimate and, thus, in this respect, the FHWA criteria are conservative.

For calculating the additional vertical stress used in estimating pullout resistance, the elastic solutions, represented by Eq. 6.4, are preferable because they produce lower

stresses and, thus, lower pullout resistance. The lower pullout resistance is probably also more realistic.

Wang (2005) performed analyses of a number of multi-tiered walls. In his analyses, he calculated pullout resistances for the reinforcement using the FHWA guidelines for the additional vertical stress caused by superimposed walls. However, he only considered the additional vertical stress caused by the wall immediately above any given wall and neglected any contributions of additional overlying walls. Thus, his approach was probably conservative in one respect (neglecting additional walls) and unconservative in another respect (using the FHWA criteria). Results of Wang's analyses of multi-tiered walls produced what appear to be reasonable results. That is, his analyses showed that the walls often just met FHWA criterion for global stability (factor of safety of 1.3), yet they appear to be stable based on successful field performance of the actual walls. Had the FHWA criterion substantially overestimated the pullout resistance, it seems that the walls would have experienced problems. Based on the limited number of analyses by Wang (2005) it appears that the FHWA criteria for estimating the additional vertical stress of superimposed walls may be used for multi-tiered walls, provided that only the immediately overlying tier is considered to contribute to the increased vertical stress.

Summary

Two approaches have been discussed for estimating the effects of overlying walls on the vertical stresses used to calculate pullout resistance in individual layers of reinforcement. The approach and criteria presented by FHWA appear to be unconservative, but may be acceptable for use provided that only the immediately overlying tier in a multi-tiered wall system is considered to contribute to the increased vertical stresses. As an alternative, the elastic solution presented in this chapter is probably more realistic and is the preferred alternative. The elastic solution may be programmed relatively easily to compute vertical stresses in a spreadsheet program.

Chapter 7 - Recommendations for Design

Introduction

In the previous chapters, approaches have been presented for estimating the forces that reinforcement must be capable of providing and for estimating the required lengths of reinforcement based on considerations of both overall stability and pullout resistance. Design charts have been presented for estimating reinforcement forces and lengths for simple multi-tiered walls with uniform heights and offsets. Although the charts are restricted to simple multi-tiered walls, the approaches used to develop the charts can be generalized and applied to walls with more complex geometries. A general approach for estimating the required forces and lengths of reinforcement is outlined in this chapter. Once the required reinforcement forces are determined, appropriate global stability analyses should be performed. Procedures and guidelines for such global stability analyses are also presented in this chapter.

Computation of Required Reinforcement Forces

In Chapter 2, the required reinforcement forces were calculated using limit equilibrium procedures of slope stability analysis. The forces were calculated by determining what force was required for equilibrium with the soil shear strength fully developed, i.e., with the factor of safety for soil shear strength equal to one. It is possible to perform such calculations in several ways. In the most direct way, the full soil shear strength is assumed to be developed and the force required for equilibrium is calculated. Calculations are performed for an assumed slip surface and various slip surfaces are tried until the slip surface yielding the maximum required force is determined. This approach requires special limit equilibrium software that is designed for calculating reinforcement forces directly. In the current study, an alternative procedure was used to calculate the required reinforcement forces. The alternative procedure can be used with any limit equilibrium software for slope stability analysis that has the capability of modeling reinforcing elements. For a general wall system the steps are as follows:

1. Establish the geometry (heights and offsets) for the walls in the multi-tiered wall system.
2. Beginning with the uppermost wall in the tiered system, assume some number of horizontal reinforcing elements, equally spaced in the vertical direction (Figure 7.1a). Five to ten layers of reinforcement should be suitable; the exact number of layers is relatively unimportant. Each reinforcement layer should be given the same force, in effect making the distribution of forces constant over the height of the wall. It was shown previously that a distribution of forces that are constant with depth produces a larger total required force than forces that increase linearly with depth. Thus, assuming a constant distribution of forces is conservative. Assume that the reinforcement is essentially infinitely long, i.e., sufficiently long so that any slip surface through the toe of the wall will intersect all layers of reinforcement.

3. Compute the factor of safety for the most critical slip surface passing through the toe of the upper wall. If the wall is embedded, the slip surfaces should pass through the lowest point on the wall face and soil in front of the wall should be neglected. The presence of lower walls should have no effect on this set of calculations. The factor of safety should be applied to soil shear strength only, which is the factor of safety that is generally computed in limit equilibrium slope stability analyses.
4. If the factor of safety computed in Step 3 is not equal to unity, i.e., the soil shear strength is not fully developed, assume a new set of forces in the reinforcement, again assuming that each layer has the same force, and repeat the calculations of factor of safety. Repeat this process until the factor of safety is one. The total force in the reinforcement that produces a factor of safety of one represents the required reinforcement force for the uppermost (top) tier of the wall.
5. Next, assume some number of reinforcing layers equally spaced in the uppermost two tiers of the wall system (Figure 7.1b). Typically, the number of layers of reinforcement assumed for the top two tiers will be twice the number of layers assumed in the top tier in Step 2. However, the number may differ if the heights of the two tiers are significantly different, in which case, the number of layers may be chosen such that the vertical spacing between layers in Tier 2 is comparable to the spacing that was assumed for the upper tier in Step 2. Assume that each layer of reinforcement has the same force and select some value for the force. The reinforcement is again assumed to be infinitely long
6. Compute the factor of safety for the most critical slip surface passing through the toe of the lowest tier of the top two tiers. If the factor of safety is not equal to unity, assume a new set of forces in the reinforcement, with each layer again having the same force. Repeat the calculations of factor of safety until the factor of safety is 1.0. The total force in the reinforcement that produces a factor of safety of 1.0 represents the required reinforcement force for the top two tiers of the wall system, combined. The force required for the lower of the two tiers should be the total force computed in Step 6 less the total force computed in Step 4 for the upper tier. As described for the design examples in Chapter 4, if the required force computed for the lower tier is less than the force in the upper tier, the force in the lower tier may be increased to equal that of the upper tier. The force required in each of the top two tiers is now established.
7. Next, the top three tiers of the wall system are considered (Figure 7.2). Again a number of reinforcement layers is assumed in the top three tiers with the reinforcement equally spaced and each layer having the same force. A trial and error procedure is used to determine the force that produces a factor of safety of one. The force determined in this manner represents the total required force, including the force required in the top two tiers. The force required in the lowest (third) tier is then determined by subtracting the forces required in the top two tiers from the force just calculated in Step 7. Again, the value of force determined in this manner may be adjusted so that it is at least equal to the force for each of the upper two tiers.

8. The above steps are repeated in a “top-down” sequence to determine the total reinforcement force required for each wall in the tiered system.

Once the total force required for each wall is determined, an appropriate number and strength of reinforcing elements can be selected for each tier to meet the force requirements. The actual number of layers of reinforcement selected for each tier in the final design can be different from what was assumed above to calculate the required forces.

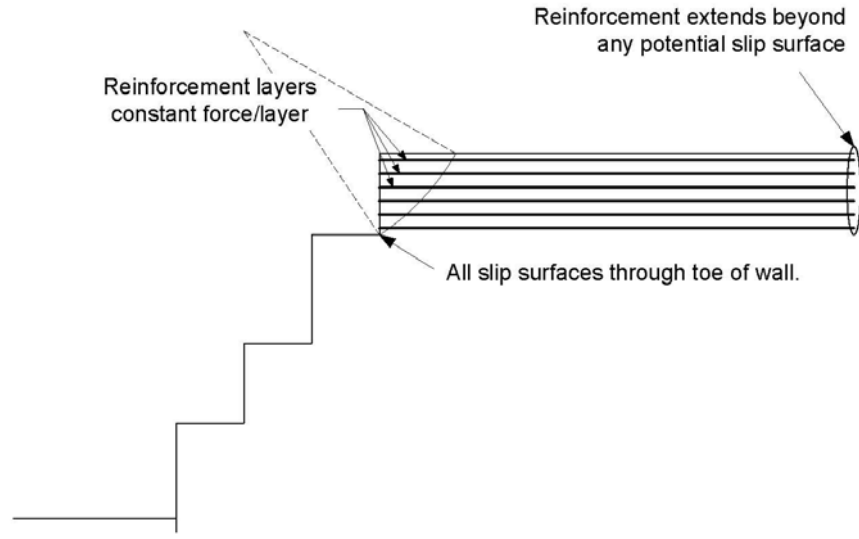

(a) Computations for upper tier only.

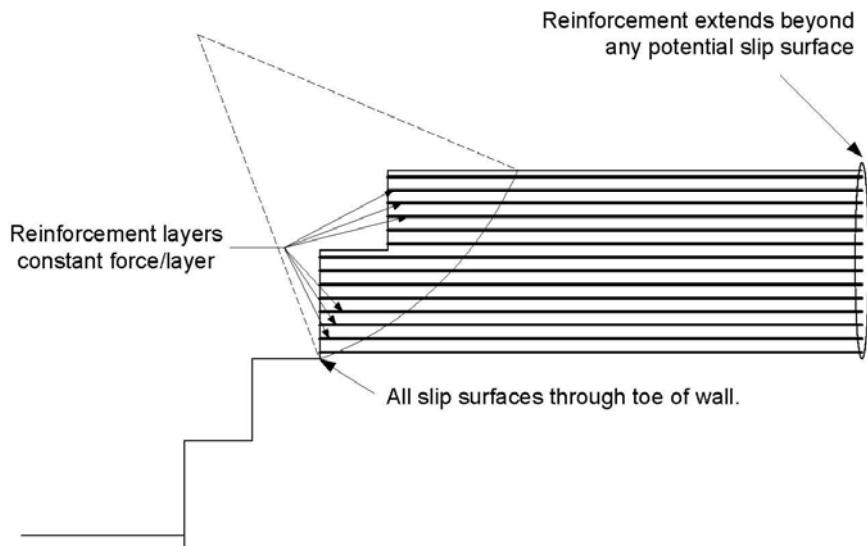

(b) Computations for top two tiers.

Figure 7.1 Assumed conditions for computation of required reinforcement forces for top two tiers of a 4 tier wall system

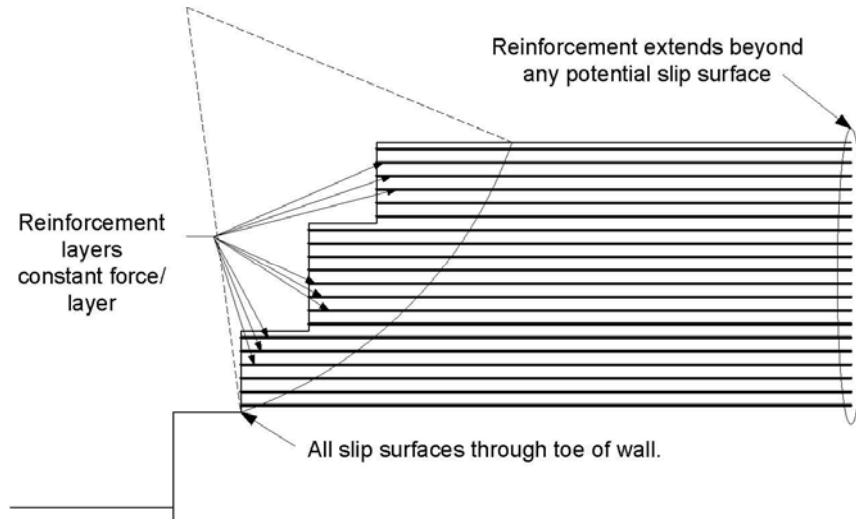

Figure 7.2 Assumed conditions for computation of required reinforcement forces for top three tiers of a 4 tier wall system

Computation of Required Reinforcement Lengths

Computation of required reinforcement lengths was discussed in Chapter 3. In Chapter 3, lengths were computed to produce the same factor of safety for overall stability of multi-tiered walls as is currently generally sought for single-tiered walls. The procedure actually involves several parts: determination of required lengths at the base of the wall, determination of the required length at the top of the uppermost wall, and determination of the required lengths for intermediate tiers.

Required Bottom Length, L_B

The required length (L_B) of reinforcement at the base of the tiered wall system is determined by finding the minimum length of reinforcement required to fully develop a friction angle, ϕ_d , of approximately 20.6° . Reinforcement is assumed to be sufficiently strong to force any slip surface outside the reinforced soil zone. The specific steps for doing this are as follows.

1. Establish the geometry (heights and offsets) for the walls in the multi-tiered wall system.
2. Assume a friction angle for the retained, reinforced, and foundation soils. Any value can be assumed for the friction angle and all soils (retained, reinforced, and foundation) should have the same friction angle. No reinforcement needs to be assumed for these computations because all slip surfaces are assumed to pass outside the zone of reinforced soil.
3. Find the critical slip surface and corresponding factor of safety for slip surfaces that pass through a point located some distance horizontally behind the toe of the lowest wall, at the same elevation as the toe (Figure 7.3).

4. Based on the slip surface and factor of safety calculated in Step 3, compute the developed friction angle, ϕ_d , from the equation:

$$\phi_d = \arctan\left(\frac{\tan \phi}{F}\right) \quad (\text{Eq. 7.1})$$

5. If the developed friction angle calculated in Step 4 is sufficiently close to 20.6° , continue with Step 6; otherwise repeat Steps 3 and 4 for points at different distances from the base of the wall (Figure 7.4). Continue until the point is found where the developed friction angle is approximately 20.6° .
6. The horizontal distance from the face of the wall to the point yielding a developed friction angle of approximately 20.6° now represents the required length (L_B) of reinforcement at the bottom of the wall (Figure 7.4).

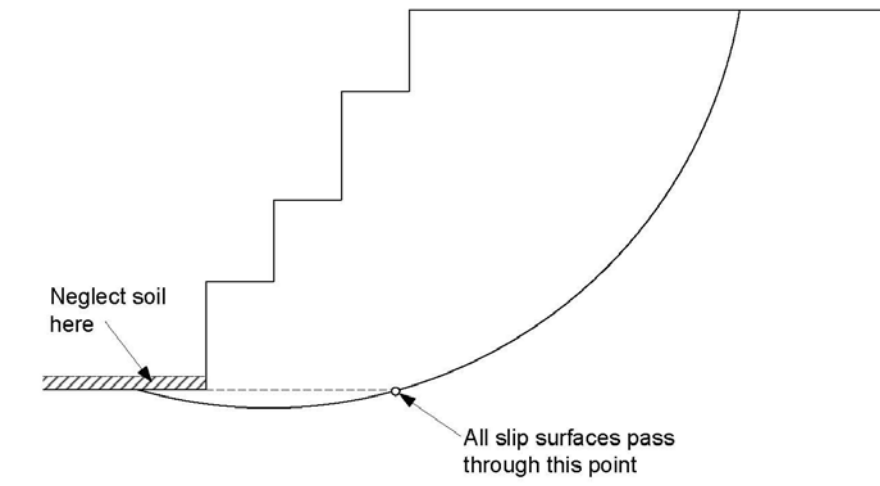

Figure 7.3 Slip surface passing through constrained point used to determine minimum required lengths of lower layers of reinforcement required to produce a developed friction angle of 20.6 degrees

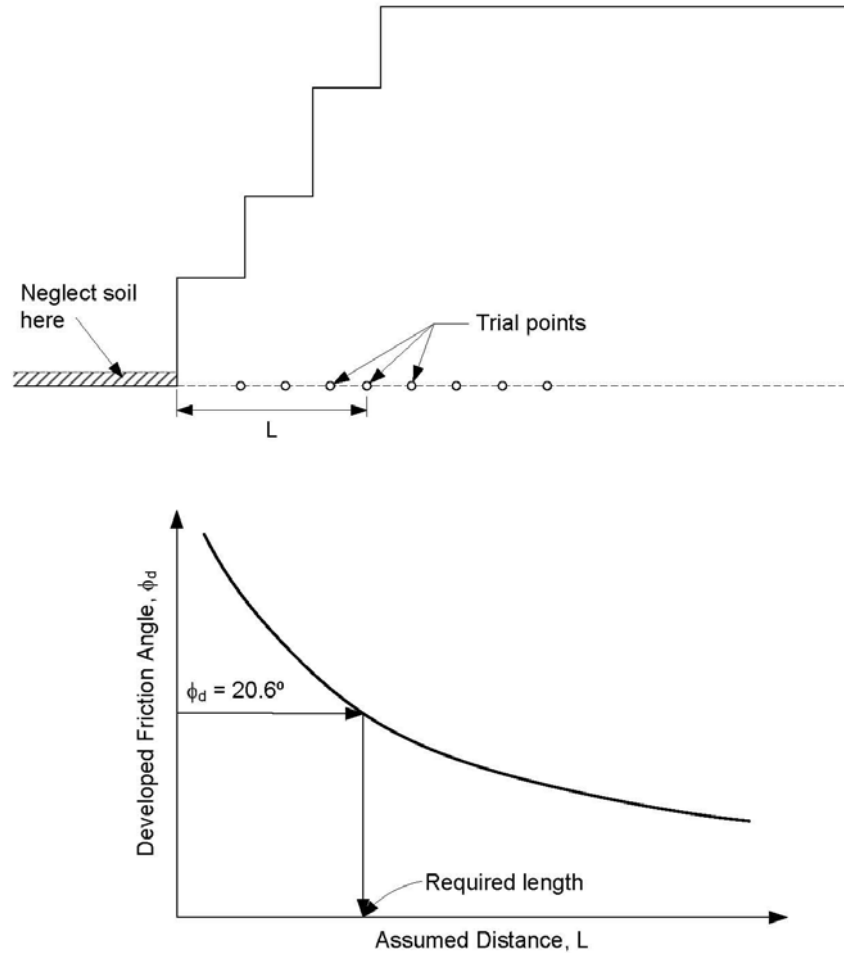

Figure 7.4 Illustration of procedure for determining the minimum length for lower layers of reinforcement required to produce a developed friction angle of 20.6 degrees

Required Top Length, L_T

The procedure for determining the required length of reinforcement at the top of the wall was described in Chapter 3. The procedure is also similar to the procedure described above for determining the required reinforcement force, except: (1) the calculations are only performed for the full wall system, rather than top-down, tier-by-tier, and (2) the forces in the reinforcement layers are assumed to increase linearly with depth. Also, only the location of the critical slip surface (rather than the forces) is of interest. The procedure for determining the required length for reinforcement at the top of the wall system is as follows:

1. Establish the geometry (heights and offsets) for the walls in the multi-tiered wall system.
2. Assume some number of horizontal reinforcing elements, equally spaced in the vertical direction (Figure 7.5). Typically, five to ten layers of reinforcement per wall tier should be suitable. The reinforcement layers should be given forces that increase linearly with depth below the top of the uppermost wall. It was shown

previously in Chapter 3 that the critical slip surface extends further behind the upper wall when a linear distribution of forces is assumed rather than a constant distribution of forces. Thus, assuming a linear distribution of forces is conservative regarding the determination of required lengths of reinforcement at the top of a tiered wall system. The reinforcement is assumed to be essentially infinitely long, i.e., sufficiently long so that any slip surface will intersect all layers of reinforcement.

3. Compute the factor of safety for the most critical slip surface passing through the toe of the multi-tiered wall system, i.e., the toe of the lowest wall. The factor of safety that is computed should be the factor of safety applied to soil shear strength.
4. If the factor of safety computed in Step 3 is not equal to unity, i.e., the soil shear strength is not fully developed, assume a new set of forces in the reinforcement and repeat the calculations for factor of safety. The forces in the reinforcement should always increase linearly with depth. Repeat Steps 3 and 4 until the factor of safety is unity. The critical slip surface determined in this manner is the slip surface corresponding to minimum active earth pressures. For a single wall, this slip surface corresponds to the slip surface for Rankine active earth pressures.
5. Once the forces and critical slip surface producing a factor of safety of one are found, determine the distance behind the face of the uppermost wall where the slip surface intersects the ground surface (Figure 7.6). This distance, L_T , represents the required minimum length for reinforcement at the top of the tiered wall system with one exception: if this distance is less than 0.7 times the height of the uppermost wall, a distance of 0.7 times the height of the uppermost wall is adopted as the minimum length of reinforcement at the top of the wall system.

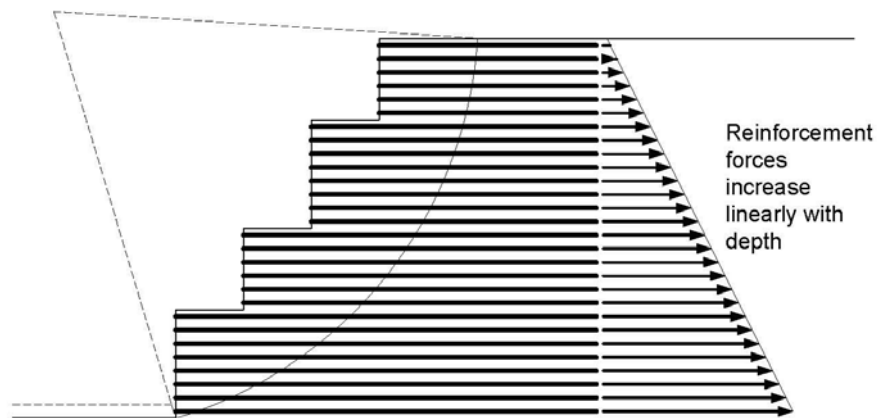

Figure 7.5 Assumed conditions for computation of failure surface (“active” zone) at the top of the tiered wall system

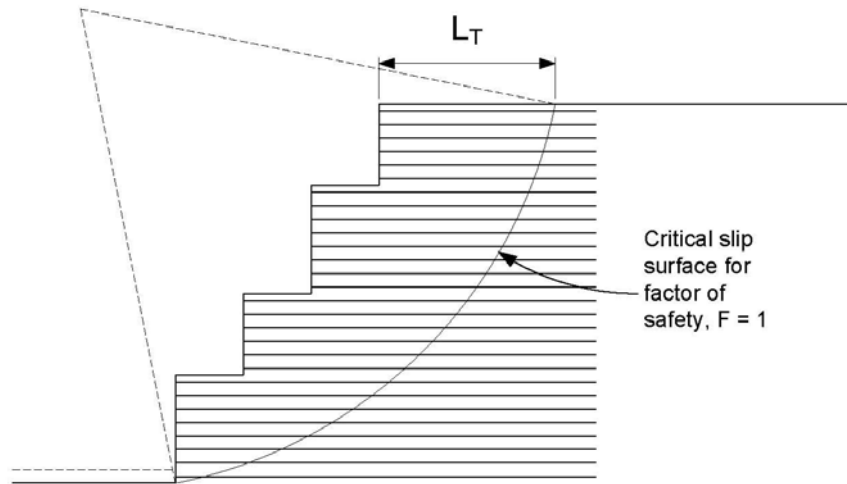

Figure 7.6 Determination of minimum length (L_T) required for reinforcement at the top of a multi-tiered wall system

Intermediate Reinforcement Lengths

Once the required reinforcement lengths for the top and bottom of the wall are determined, the minimum lengths of reinforcement for intermediate layers are determined as illustrated earlier in Chapter 3 and in Figure 7.6.

Additional Length for Pullout

The lengths determined by the procedures described above represent the required lengths along which the full reinforcement design strength can be developed. It is recommended that the long-term allowable design strength, T_{al} , as stipulated by the current FHWA guidelines, be used as the design strength. An additional length, representing the length required to develop pullout resistance equal to the design strength, must be added to the reinforcement lengths determined by the procedures above. The additional “pullout resistance development length,” L_p , is calculated from the equation:

$$L_p = \frac{T_{al}}{p_r} \quad (\text{Eq. 7.2})$$

where, p_r is the unit pullout resistance calculated using the procedures described in Chapter 6. The total required length of reinforcement is the combination of the length determined using the procedures illustrated in Figure 7.7 and the additional pullout resistance development length, L_p .

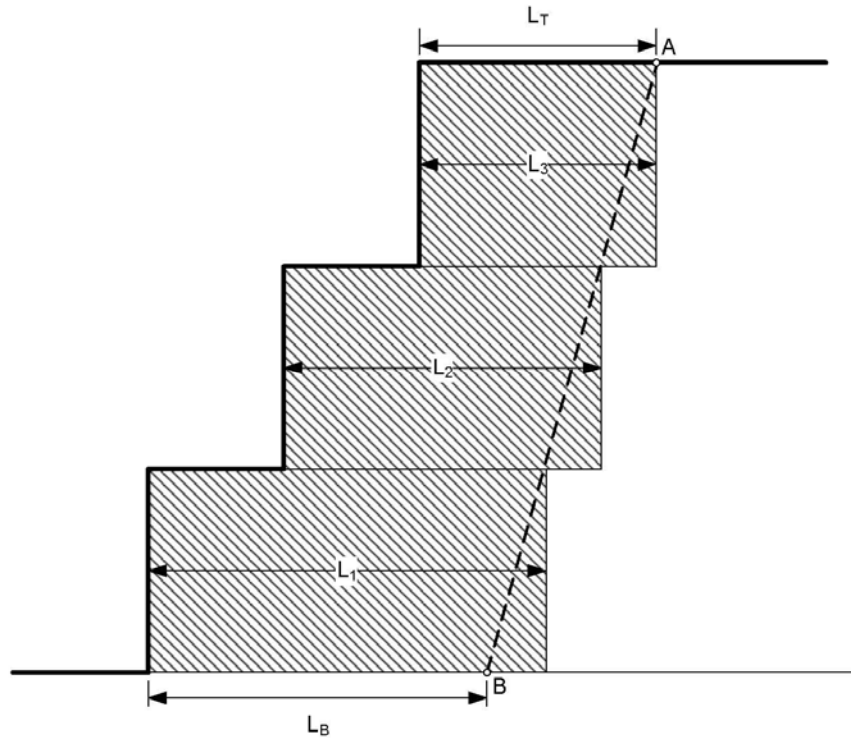

Figure 7.7 Determination of lengths of intermediate reinforcement for multi-tiered walls

Global Stability Analyses - Assumptions for Analyses

The procedures described in the previous sections of this chapter as well as those described in Chapters 2, 3, and 6 provide a basis for establishing preliminary requirements for reinforcing elements in mechanically stabilized earth walls. Reinforcement meeting these requirements is expected in most cases to provide adequate global stability of a multi-tiered retaining wall system. However, before any design can be considered final and acceptable, additional limit equilibrium analyses should be performed to investigate potential modes of instability. These analyses are termed “global” stability analyses, and they may involve slip surfaces that range from being contained entirely within the reinforced soil behind the wall to lying entirely outside the reinforced soil zone (Figure 7.8).

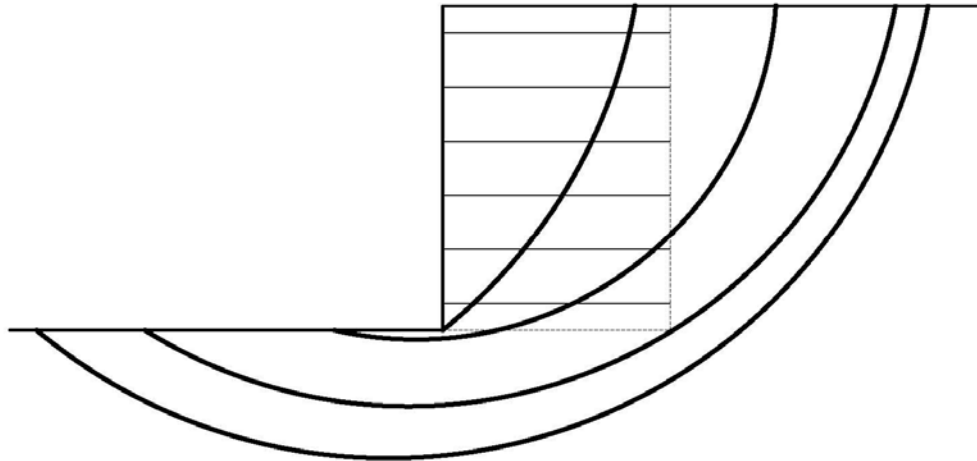

Figure 7.8 Potential critical slip surfaces for “global” stability analyses

Osborne (2004) and Wang (2005) performed an extensive series of global stability analyses of a number of multi-tiered MSE walls designed and built by TxDOT and also reviewed results of global stability analyses performed by others as part of the design. These efforts revealed that a wide range in factors of safety may be computed depending on assumptions made in the global stability analyses. The various assumptions are discussed briefly below and recommendations are made regarding each.

Embedment of Wall

The face of one or more of the walls in a tiered wall system is normally embedded some distance below the ground surface. Because this soil generally does not exist during construction and may also be removed at some time after final construction, it is recommended that the presence of soil in front of the wall be neglected in global stability analyses.

Surcharge

Designers often must consider various surcharge loads on the top of one or more of the walls in the wall system. Depending on the designer and design procedures being followed the surcharges may be described as “live load” or “dead load” or some combination of the two. A review of software and analyses performed by others suggests that live and dead loads are sometimes treated differently and may or may not be included in the computations of global stability. However, regardless of whether the surcharge is a live load or a dead load, it is recommended that any surcharge be included in the computation of global stability.

Definition of Factor of Safety

Various definitions have been used for the factor of safety computed in limit equilibrium analyses. Factors of safety can be applied to the soil shear strength, the reinforcement resistance, or both the soil strength and reinforcement resistance. The current FHWA guidelines do not stipulate how the factor of safety is to be defined for

global stability analyses. However, it appears that the factor of safety has usually been applied to shear strength only. This is the practice normally used in limit equilibrium analyses of earth slopes and it is recommended that in the limit equilibrium analyses for global stability of MSE walls, the factor of safety be applied to soil shear strength only. This, however, does not preclude applying a separate factor of safety to the reinforcement forces, as suggested below, *before* the limit equilibrium analyses are performed.

Design Reinforcement Force

Analyses of actual wall designs prepared for TxDOT suggested that global stability of many of the walls was calculated using the long-term strength of the reinforcement provided by manufacturers with no additional factor of safety applied to the reinforcement forces. This strength is termed the “long-term material strength” and designated as T_a in the FHWA guidelines. No factor of safety is applied to this strength. However, for global stability analyses, it seems reasonable to apply some factor of safety to the reinforcement resistance in addition to the factor of safety that is applied to soil shear strength as described in the previous item above. Accordingly, it is recommended that the “long-term allowable reinforcement strength,” designated as T_{al} in FHWA guidelines, be used to compute global stability. The long-term allowable design strength (T_{al}) includes an appropriate factor of safety and strength reduction factors to account for various environmental and construction effects.

Limit Equilibrium Procedure Used

Several different limit equilibrium procedures of slices have been and are used to compute the factor of safety for global stability analyses. For example, AASHTO guidelines stipulate that the Simplified Bishop, Simplified Janbu, or Spencer’s procedure may be used. However, the Simplified Janbu procedure, which does not fully satisfy equilibrium, can produce factors of safety that differ by 25 percent or more from the values by more rigorous procedures that do satisfy equilibrium. In general, it is recommended that Spencer’s procedure or another procedure, which also fully satisfies equilibrium, be used. The Simplified Bishop procedure may also be used. Although the Simplified Bishop procedure does not satisfy complete static equilibrium, it has been found to be reasonably accurate. The major limitation of the Simplified Bishop procedure is that the procedure is restricted to circular slip surfaces while Spencer’s procedure can be used to analyze slip surfaces of any shape.

Orientation of Reinforcement Forces

Virtually all reinforcement used in MSE walls is placed in horizontal layers, and is not inclined. The tensile resistance provided by the reinforcement can either be assumed to be horizontal or the resisting forces can be assumed to be inclined at some angle due to rotation of the reinforcement where it crosses the slip surface. For example, in the MSEW 2.0 software, the default assumption is that the reinforcement is rotated such that the reinforcement and tensile forces are tangential to the slip surface (Osborne, 2004). However, any properly designed MSE wall should probably not experience significant deformations to cause such a reorientation of the reinforcement forces. It is

recommended that for the global stability analyses, the reinforcement forces be assumed to be horizontal, in the original direction of the reinforcement layers.

Transfer of Reinforcement Force to Slip Surface at Exit Point

When a slip surface being analyzed passes through the face of an MSE wall at the same level as a layer of reinforcement, the force provided by the reinforcement may or may not be included as a resisting force in the stability computations (Figure 7.9). For example, in the MSEW2.0 software, when a slip surface exits at the same level as a layer of reinforcement, the full resisting force of the reinforcement is included in the stability computations. In contrast with software like the UTEXAS4 software, the reinforcement is assumed to provide no resistance to the overlying soil mass. In reality, the resistance provided by the reinforcement is probably somewhere between the two extremes (full and no contribution of resistance). However, because the actual contribution of the reinforcement in this case is not known, it is recommended that the contribution of a reinforcement layer at the point where the slip surface exits a wall face be neglected.

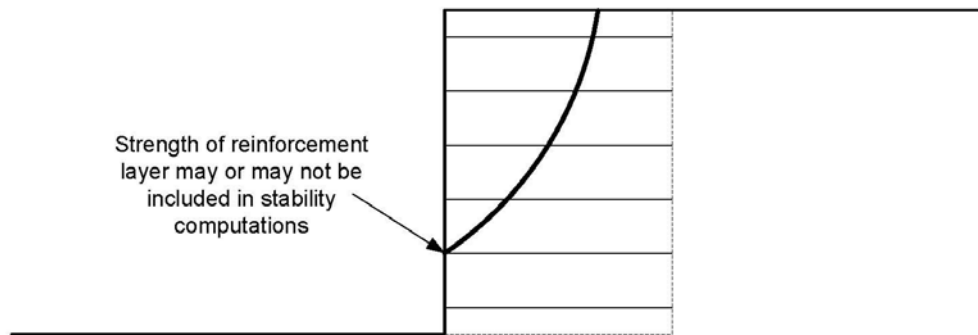

Figure 7.9 Slip surface exiting wall face at the same elevation as a layer of reinforcement

Global Stability Analyses - Locating the Most Critical Slip Surface

In addition to the various assumptions and conditions described in the previous section, location of the most critical (lowest factor of safety) slip surface is an important part of global stability analyses. Wang (2005) performed extensive global stability analyses for several actual multi-tiered MSEW walls designed for TxDOT. Based on these analyses, he provided recommendations for procedures for locating the most critical slip surface. These procedures are applicable to the walls analyzed and the UTEXAS4 software used. However, because different software uses different methods for searching for the critical slip surface—procedures vary from random searches to systematic searches—different approaches will most likely be required depending on the software used. Also the procedures are likely to vary somewhat depending on the particular geometry of the multi-tiered wall system.

Almost all searches for critical slip surfaces begin with some prescribed starting conditions for the search. In general, searches should be conducted with starting conditions that encompass the following slip surfaces:

1. Slip surfaces that pass through the toe and “heel” points of the lowest wall, and encompass all walls (Figure 7.10).
2. Slip surfaces that encompass all combinations of the various walls in the system and pass through the toe of the lowest wall in each combination considered (Figure 7.11).
3. Slip surfaces that exit each level of reinforcement (Figure 7.12). Judgment may be required to determine if such slip surfaces encompass only the wall whose face is being considered (Figure 7.12a) or several walls in the tiered system (Figure 7.12b).

Searches should also be conducted which include slip surfaces that pass entirely below the wall and reinforced soil zone (Figure 7.13).

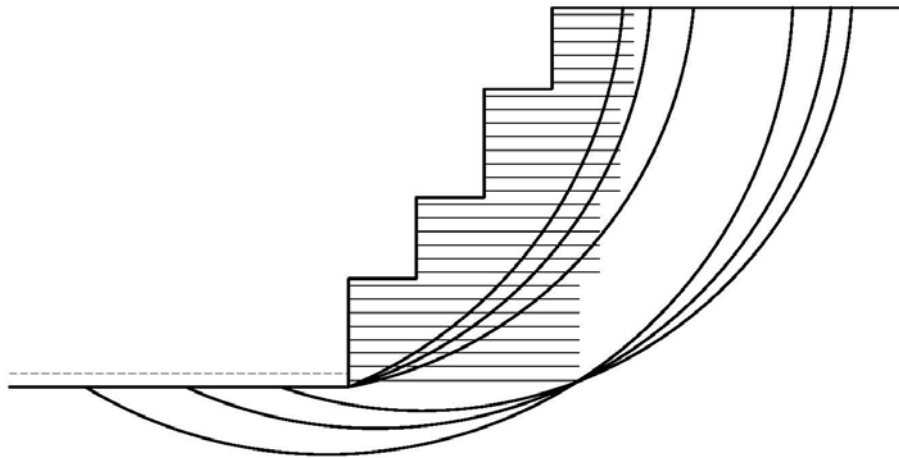

Figure 7.10 Trial slip surfaces for global stability analyses—through toe and heel of lower wall

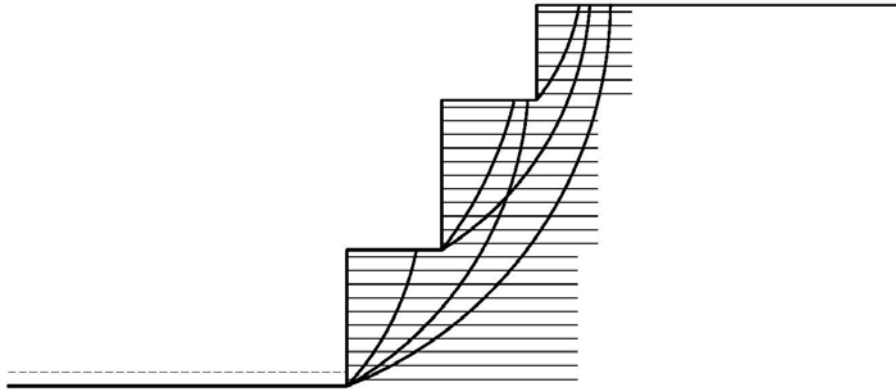
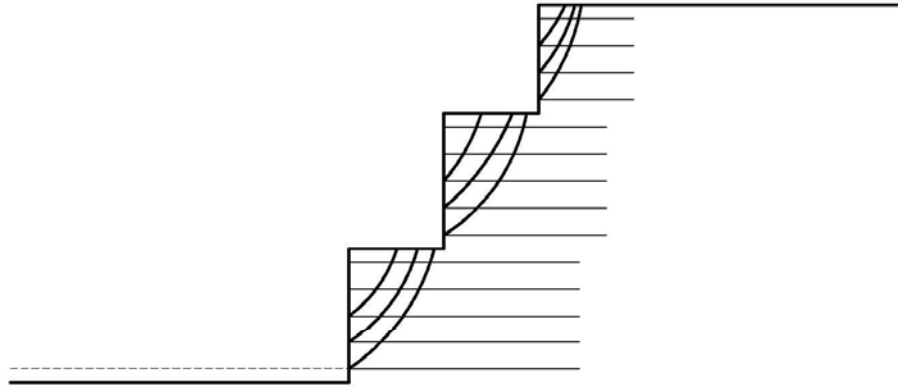
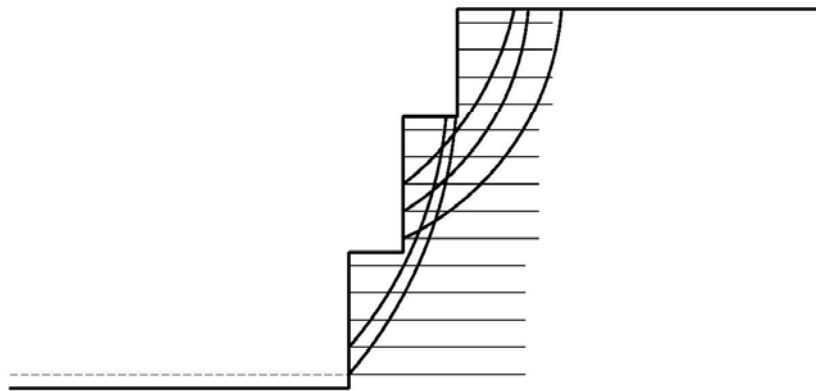

Figure 7.11 Trial slip surfaces for global stability analyses—through all combinations of walls and toe of lower wall



(a) Slip surfaces involving only a single wall



(b) Slip surfaces involving more than a single wall.

Figure 7.12 Trial slip surfaces for global stability analyses—exiting at level of each layer of reinforcement

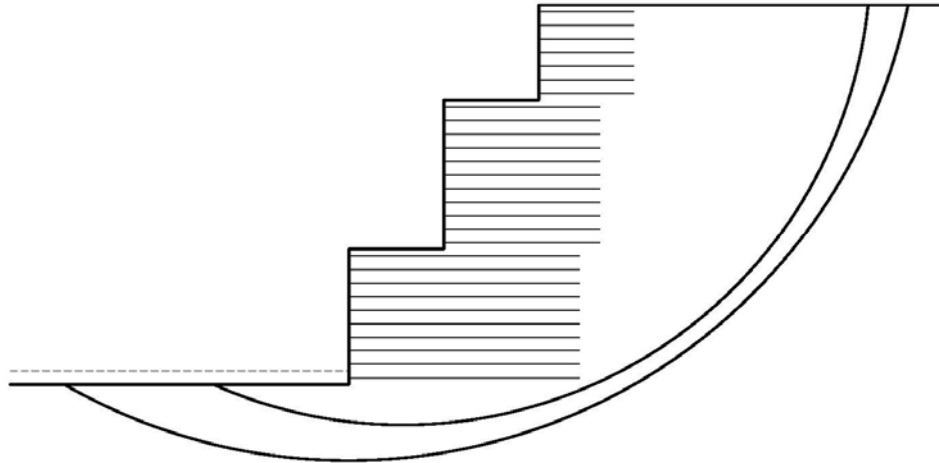

Figure 7.13 Trial slip surfaces for global stability analyses—external to wall and reinforced soil

Another important variable in searches is the amount (distance) that various trial slip surfaces are moved, shifted, etc. during the search. The distance between trial points and trial slip surfaces becomes especially important for reinforced slopes and walls because a small shift in the location of a slip surface can affect which layers of reinforcement are intersected. In all of the analyses performed for the current study and reported by Osborne (2004) and Wang (2005) using the UTEXAS4 software, a “grid” was used for the search and the spacing between adjacent grid (circle center) points was selected to be 1 percent of the total wall height. For example, for a 25 foot high wall, a grid spacing of 0.25 feet was used. Although this distance (0.25 feet) is very small, computers are now sufficiently fast that computation times are small. Often well under one minute, and generally no more than a few minutes are required for a given search.

Summary

The limit equilibrium procedures described in this chapter can be used with any general, comprehensive computer program for slope stability analysis that is capable of modeling internal reinforcing. Although the procedures were used in this study with the UTEXAS4 software, the procedures can also be used with such software as “SLOPE/W” by GEO-SLOPE International, and “SLIDE 5.0” by Rocscience, Incorporated.

Chapter 8 - Summary, Conclusions, and Recommendations

Summary

Design of MSE walls usually begins by estimating the forces that the reinforcement must be capable of resisting and the length of the reinforcement. Procedures for estimating the forces are presented in Chapter 2 along with simple charts that can be used to calculate the forces. In Chapter 3, procedures, including simple design charts, are presented for estimating the required minimum length of the reinforcement. The procedures described in Chapters 2 and 3 are applied to the design of several hypothetical walls in Chapter 4 and two actual walls designed and built for TxDOT in Chapter 5. In Chapter 6, internal stability of multi-tiered MSE walls is considered. Specifically, the estimation of vertical stresses and resistance of the reinforcement to pullout from the soil are discussed. Pullout resistance must be estimated and used to calculate the length required to develop the design capacity of the reinforcement. The length required to develop the design capacity must be added to the required lengths discussed in Chapter 3 to determine the total required length of the reinforcement. In Chapter 7, general design recommendations are discussed, including step-by-step procedures for estimating required strength and length of reinforcement for walls that are more complex than the walls considered in Chapters 2 and 3, e.g., walls with varying tier heights and varying offset distances. Global stability analyses, which are required for design of all MSE walls, are also discussed in Chapter 7.

Conclusions

The procedures presented in this report provide a rational basis for establishing the reinforcement requirements for multi-tiered MSE walls. The procedures are consistent with the procedures currently used for design of single-tiered walls in the sense that they are based on limit equilibrium procedures and employ similar factors of safety. Although the procedures developed and presented here do not consider deformations directly, and no experimental or field measurements of deformations were available, the procedures have been applied to actual walls designed and built for TxDOT. The procedures produced results consistent with the designs for these walls and the walls that have been built have performed satisfactorily. Thus, there is at least indirect support for the procedures.

Currently, there is not a consistent definition of the factor of safety for reinforced soil structures. For retaining walls, the soil shear strength is assumed to be fully developed, i.e., no factor of safety is applied to soil strength, and the (reinforcement) forces required for equilibrium are calculated. A factor of safety is then applied to the reinforcement forces. In contrast, for reinforced slopes, the factor of safety is applied to the soil shear strength and the reinforcement forces are calculated. In one case (walls), the factor of safety is applied to reinforcement forces; in the other case (slopes), the factor of safety is applied to soil strength. Depending on the definition of the factor of safety, the values will be different. The author prefers an approach where an appropriate factor of safety is

first applied to the reinforcement and the factored forces are then used in a limit equilibrium analysis to compute a factor of safety applied to soil shear strength.

Recommendations

The procedures presented in this report are believed to be reasonable and consistent with similar procedures used to design single-tiered MSE walls and reinforced slopes. However, a need still exists to “calibrate” the procedures by establishing acceptable values for the factor of safety. Little is known about the deformations of multi-tiered walls and how the deformations may be related to factors of safety. The fact that the procedures seem to produce results that are consistent with the successful performance of several multi-tiered walls designed and built for TxDOT is promising. Analyses of additional case histories of actual walls are encouraged. Parametric finite element analyses should also prove useful in establishing guidelines for factor of safety based on acceptable deformations of the wall system. Until such time as further case histories can be analyzed and/or finite element analyses can be performed, it seems reasonable to require a factor of safety of 1.5 with respect to shear strength as computed from limit equilibrium analyses using allowable (factored) reinforcement forces. Allowable reinforcement forces can be estimated using present FHWA criteria for single-tiered walls.