



**CIV - Civil Infrastructure Vision© v1.0:
Bridge Calibration User Manual
and Validation Manual**

Research Report 0-6950-1
Cooperative Research Program

UNIVERSITY OF TEXAS AT SAN ANTONIO
DEPARTMENT OF CIVIL AND ENVIRONMENTAL ENGINEERING
SAN ANTONIO, TEXAS 78249

in cooperation with the
Federal Highway Administration and the
Texas Department of Transportation

TECHNICAL REPORT DOCUMENTATION PAGE

1. Report No. FHWA/TX-21/0-6950-1	2. Government Accession No.	3. Recipient's Catalog No.	
4. Title and Subtitle CIV - Civil Infrastructure Vision© v1.0: Bridge Calibration User Manual and Validation Manual	5. Report Date December 2020 Published: December 2021		6. Performing Organization Code
	8. Performing Organization Report No. 0-6950-1		
7. Author(s) Wassim M. Ghannoum, Ph.D. https://orcid.org/0000-0003-2631-7690 Manuel Diaz, Ph.D. https://orcid.org/0000-0001-9448-4437 Shima Rajaei Suman Banjade Biswash Chapagain Graham Hogsett	9. Performing Organization Name and Address University of Texas at San Antonio One UTSA Circle San Antonio, TX 78249		
12. Sponsoring Agency Name and Address Texas Department of Transportation Research and Technology Implementation Division 125 E. 11th Street Austin, TX 78701	10. Work Unit No.		11. Contract or Grant No. 0-6950
	13. Type of Report and Period Covered Research Report (Sep 2017-Dec 2020)		
15. Supplementary Notes Project performed in cooperation with the Texas Department of Transportation and the Federal Highway Administration. Project title: Evaluating Bridge Behavior Using Ultra-High Resolution Next-Generation Digital Image Correlation (DIC): Applications in Bridge Inspection and Damage Assessment	14. Sponsoring Agency Code		
	16. Abstract An integrated software/hardware system was developed that can be used to monitor surface deformations on structural components ranging from small-scale material-test coupons, to full-scale bridge members. The system delivered to the Texas Department of transportation is dubbed the Civil Infrastructure Vision (CIV) System and is intended to measure bridge deformations and strain during load testing. In the Bridge Calibration edition, the CIV system is calibrated for measuring deformations on large-scale specimens that are 40ft to 110ft away from the cameras. Accuracy of measurements are on the order of a few thousandths of an inch over the full measurement volume. The non-contact system offers several advantages over traditional contact measurement methods, including: ease and speed of setup, reduction in traffic disruptions, and distributed measurements over large areas of a structural system (as opposed to point measurements). The system is based on principles of Digital Image Correlation (DIC) and spatial triangulation to determine the 3D spatial coordinates of user-selected targets. In the CIV system, targets can be selected at any point on the surface of the structural system being monitored. A user manual and a validation manual are provided, which describe the system, how to use it, and how to validate its accuracy over a measurement volume.		
17. Key Words Bridge load testing, deformation, strain, measurements, digital image correlation	18. Distribution Statement No restrictions. This document is available to the public through the National Technical Information Service, Alexandria, Virginia 22312, https://www.ntis.gov/ .		
19. Security Classif. (of this report) Unclassified	20. Security Classif. (of this page) Unclassified	21. No. of Pages 85	22. Price

CIV - Civil Infrastructure Vision © - v1.0

Bridge Calibration

User Manual

DISCLAIMER

Considerable time and effort have gone into the development and testing of this software and hardware measurement system. However, the user accepts and understands that no warranty is expressed or implied by the developers or the distributors on the accuracy or the reliability of this product.

This product is a practical and powerful tool for measuring structural deformations. However, as with all measurement devices, errors in readings may increase over time, or develop if the cameras are displaced from their original relative position. The user must regularly verify that the accuracy of the system measurements are within their acceptable tolerances and request a re-calibration if needed.

The information produced by the software must be checked by a qualified and experienced engineer. The engineer must independently verify the results and take professional responsibility for the information that is used.

Contents

1	INTRODUCTION.....	1
1.1	General.....	1
1.2	Content.....	1
2	Using Digital Image Correlation to Calculate Three-Dimensional Spatial Movements.....	2
2.1	Digital Image Correlation (DIC)	2
2.2	Triangulations of Object Location and Movement in 3D Space	2
2.3	Calibration of a 3D DIC System	3
3	SYSTEM HARDWARE AND SOFTWARE	5
3.1	HARDWARE.....	5
3.1.1	Cameras and Lenses	5
3.1.2	Computer and PCIe Expansion Box.....	6
3.1.3	System Connectivity	7
3.1.4	Power supply	8
3.1.5	Supplied Optional Hardware	8
3.1.6	Optional Hardware that is not Supplied	10
3.2	SOFTWARE.....	11
3.2.1	Software Components.....	11
4	RUNNING A LIVE TEST	12
4.1	Initial Camera Positioning.....	12
4.1.1	Measurement Volume (MV).....	12
4.1.2	Wind and Vibrations.....	13
4.1.3	Lighting Considerations	14
4.2	Targets and Target Tracking Considerations.....	14
4.2.1	Target Size	14
4.2.2	Target Quality.....	15
4.2.3	Target Stability	16
4.2.4	Lighting Considerations	16
4.3	Running a Live Test using the Live Test Module	18

4.3.1	Main Menu	19
4.3.2	Camera Detection.....	20
4.3.3	Project Data	21
4.3.4	Camera Setup	22
4.3.5	Load calibration	24
4.3.6	Target Selection.....	26
4.3.7	Reference Images	30
4.3.8	Plotting	31
4.3.9	Run Test.....	34
4.3.10	Live Test Output files and folder structure	36
5	POST-PROCESSING OF TEST DATA	38
5.1	Reprocessing Existing Images	38
5.1.1	Project Selection.....	38
5.1.2	Load Calibration	40
5.1.3	Target Selection.....	40
5.1.4	Plotting	40
5.1.5	Simulate Test	41
5.2	Interpolating Existing Data	41
5.3	Smoothing of Existing Data.....	42
5.4	Calculating from Data	45

LIST OF FIGURES

Figure 2-1 Triangulation using DIC	3
Figure 2-2 Sample dot-based calibration board	4
Figure 2-3 Dots of calibration board detected in images from the Left (top) and Right (bottom) cameras.....	4
Figure 3-1: CIV system cameras and lenses.....	5
Figure 3-2: Laptop and PCIe expansion box	7
Figure 3-3: System connectivity for a Live Test	8
Figure 3-4: Supplied High-Contrast Physical Targets (HCPT)	9
Figure 3-5: Double-sided tape on target and extension rod.....	10
<i>Figure 4-1: Fields of view and the measurement volume of the CIV Bridge system.....</i>	<i>13</i>
Figure 4-2 Example surface markings on concrete and steel surfaces that can be tracked reliably by the CIV system.....	15
Figure 4-3 Targets under direct sunlight (top) and targets under shade (bottom).....	17
Figure 4-4 Shift in target location due to lighting variation at 30ft using 100x100 pixel HCPT....	18
<i>Figure 4-5: Main Menu screen</i>	<i>19</i>
Figure 4-6: Navigation buttons within each module screen.....	20
Figure 4-7: Camera Detection screen showing dark green markers (top) when the cameras are not detected and light green (bottom) when they are detected.....	21
<i>Figure 4-8: Project Data screen.....</i>	<i>22</i>
Figure 4-9: Camera Setup screen.....	23
Figure 4-10: Calibration screen.....	24
Figure 4-11: Dialog box for selecting the folder in which the calibration files are saved	25
Figure 4-12: Sample key properties of the loaded calibration	25
Figure 4-13: Target Selection screen	26
<i>Figure 4-14: Selecting a target in the Left camera image.....</i>	<i>27</i>
Figure 4-15: Moving the search window to locate the same target in the Right camera image .	27
Figure 4-16 Evaluated Target result	28
Figure 4-17: Created targets seen on the images of test specimen from both cameras.....	29
Figure 4-18 selection of targets for Origin, X axis and Y axis of the user coordinate system.....	30
Figure 4-19 Reference Images screen.....	31
Figure 4-20 Reference image averaged target coordinates in the coordinates output file	31
Figure 4-21: Plotting screen: selecting the number of plots and coordinate system	32
Figure 4-22 Selection of data type and target numbers for plotting	33
Figure 4-23 Run Test screen before a test is started.....	34
Figure 4-24 Run Test screen after a test is started, the run button is pressed, and images and data are being saved. Plot 2 is being displayed here.	35

Figure 4-25 Test is started, data is being saved, 27 images are in the queue to be saved	36
Figure 4-26 Files and folders saved in the project folder during a Live Test.....	37
Figure 4-27 Sample target-coordinate output file content	37
Figure 5-1 Post-Processing screen showing the modules	38
Figure 5-2 Project Selection screen: Project folder selection	39
Figure 5-3 Minimum folders required for Reprocess Existing Module	39
Figure 5-4 Project Selection screen: illustration of information displayed after a Project folder is loaded	40
Figure 5-5 Selecting Image Range in Simulate Test Screen	41
Figure 5-6 Interpolation of the Existing Data Screen.....	42
Figure 5-7 Smoothing data screen	43
Figure 5-8 Comparison of original file (top) and interpolated file(bottom).....	44
Figure 5-9 Calculate from Data Screen	45
Figure 5-10 Calculated file populated from a target coordinate data file	46

LIST OF TABLES

Table 4-1: Viewing angles for CIV Bridge camera lenses	12
Table 4-2: Measurement volume dimensions.....	13
Table 4-3: Physical dimensions of targets of various pixel sizes at different measurement distances	15

1 INTRODUCTION

1.1 General

The Civil Infrastructure Vision (CIV) system is an integrated software/hardware system that can be used to monitor surface deformations on structural components ranging from small-scale material-test coupons, to full-scale bridge members. *In the Bridge Calibration edition, the CIV system is calibrated for measuring deformations on large-scale specimens that are 40ft to 110ft away from the cameras. The horizontal fields of view corresponding to those offset distances range from 17ft to 47ft.* The non-contact system offers several advantages over traditional contact measurement methods, including: ease and speed of setup, reduction in traffic disruptions, and distributed measurements over large areas of a structural system (as opposed to point measurements).

The system is based on principles of Digital Image Correlation (DIC) and spatial triangulation to determine the 3D spatial coordinates of user-selected targets. In the CIV system, targets can be selected at any point on the surface of the structural system being monitored.

1.2 Content

This user manual presents an overview of Digital Image Correlation (DIC) principles and spatial triangulation principles that are utilized by the CIV system (Chapter 2). All the hardware and software components of the system are outlined in Chapter 3. Step by step instruction on how to use the software is provided in Chapters 4 and 5. Chapter 4 focuses on the Live Test module through which images and data is collected live during a test. Chapter 5 discusses the post-processing modules that can be used to reprocess images and data collected during a Live Test.

2 Using Digital Image Correlation to Calculate Three-Dimensional Spatial Movements

2.1 Digital Image Correlation (DIC)

Digital Image Correlation is an optical measurement method that recognizes patterns in images to track features in a sequential series of images. First, an image is taken using a digital sensor. A sensor is an analog to digital converter that converts light to a digital value based on intensity and frequency content. Subsets of the image, which consist of a grouping of pixels, are then selected by the software user. These subsets are called targets and tracking these targets in successive images is the foundation of Digital Image Correlation. The software then locates in pixel coordinates (x_i, y_i) the location of the selected targets in the original image. For each subsequent image, the DIC algorithms search for the pixel groups that match the signature of the targets in the original image. The outcome are pixel coordinates locating the targets in each of the successive images.

2.2 Triangulations of Object Location and Movement in 3D Space

In order to identify the three-dimensional coordinates of points on a surface (X_i, Y_i, Z_i) , a pair of images are needed from cameras whose positioning relative to each other is known. The same targets, or groups of pixels, are located using DIC algorithms in each the Left and Right camera image in pixel coordinates, (x_{iL}, y_{iL}) and (x_{iR}, y_{iR}) . Then, using principles of triangulation, the pixel coordinates obtained from each of the pairs of image are converted to spatial coordinates as illustrated in Figure 2-1.

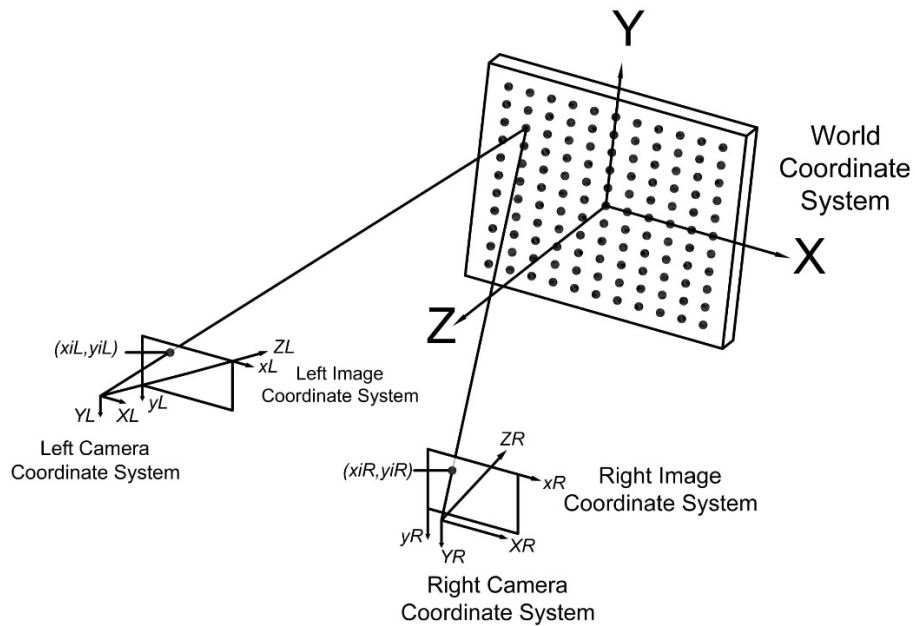

Figure 2-1 Triangulation using DIC

2.3 Calibration of a 3D DIC System

Calibration of a 3D system involves two steps. The camera model calibration is performed for each camera first, followed by a stereo calibration for the pair of cameras. Single camera calibration computes **Internal Parameters**, including a distortion model and its coefficients, the focal length, and the optical center for each camera. This step produces mathematical models that compensate for lens and sensor distortion. Through the stereo calibration, **External Parameters** are calculated that consist of rotation and translation matrices representing the relative position of the two cameras. If a camera changes position or focal length, camera model calibration for the camera and stereo calibration for the entire stereo vision system need to be repeated.

The calibration process requires a calibration board that may consist of a white board with a grid of dots (Figure 2-2). Other, checkered patterned boards can also be used. For a dotted board, the dots need to have a uniform and known center-to-center distance. The calibration software finds the dots on the board in a set of calibration images, as shown in Figure 2-3. It then uses the perceived dot locations in the calibration images and the actual known relative distance

between the dots on the board to map pixel coordinates in the two camera images to real-world coordinates.

The CIV system is delivered pre-calibrated with this calibration process already performed.

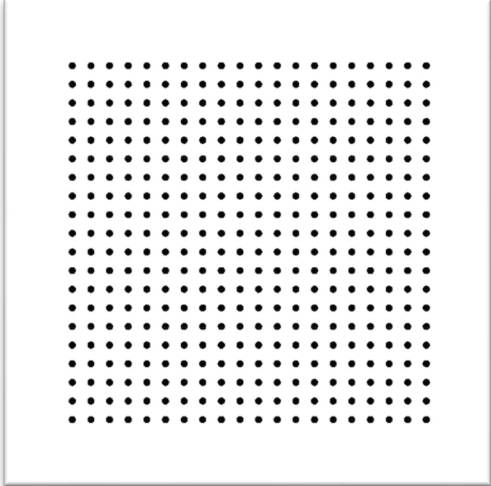

Figure 2-2 Sample dot-based calibration board

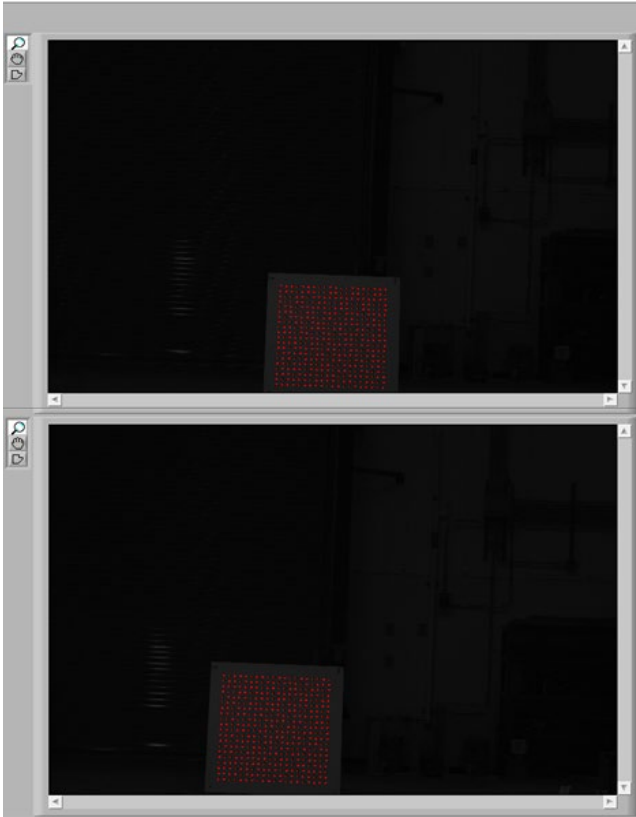

Figure 2-3 Dots of calibration board detected in images from the Left (top) and Right (bottom) cameras

3 SYSTEM HARDWARE AND SOFTWARE

3.1 HARDWARE

At the heart of the CIV system are two high-resolution, low-noise digital cameras. The cameras are attached to an aluminum bar and blocked from relative movement with respect to each other. Fixing relative camera position is essential for the system to correctly triangulate the location of targets in three-dimensional space. The aluminum bar can be attached to a tripod, while the cameras connect to a computer that runs the CIV software. The cameras connect through two GigE Ethernet ports on the computer.

3.1.1 Cameras and Lenses

The CIV system cameras are two Allied Vision Pro Silica GT6400 Monochrome cameras (Figure 3-1). The cameras have 31.4 megapixel monochrome sensors. At full frame resolution, a frame rate of 3.75 images per second can be achieved. The cameras are designed to operate without condensation within the temperature range of -20°C to $+50^{\circ}\text{C}$. The cameras connect to a computer using gigE Ethernet ports with RJ45 connectors. The cameras are capable of Trigger over Ethernet, which is employed in CIV. Each camera draws a maximum of 6.7 watts of power from a 110V outlet.



Figure 3-1: CIV system cameras and lenses

The choice of lens properties depends on the application. The following lens parameters need to be considered in DIC systems: 1- lens distortion, 2- lens focal length, 3- lens aperture.

- 1- In all cases, low-distortion lenses are desirable. Even though the calibration process compensates for lens distortion, it fits a mathematical model to the distortion, and therefore lenses with smoother distortion profiles will allow the calibration to better compensate for it.
- 2- Focal length determines the angle of the field of view. A low focal length provides a wide viewing angle and therefore a wider field of view for any particular distance from the target. A larger focal length focuses on a smaller field of view, which allows higher resolution measurements. A balance must be struck when selecting the lens focal length between how large of a field of view is desired and the resolution of the data needed.
- 3- Aperture refers to the opening of a lens's diaphragm through which light passes. This parameter governs the distance range over which an object is in focus. A large F-stop number (e.g., f/16) indicates a small aperture or opening, which makes images darker but delivers a relatively large in-focus distance range. The opposite is true for small F-stop numbers.

For a system targeting bridge load testing (CIV Bridge), selected lenses are Zeiss Planar T*1,4/85mm fixed focal length lenses. The lenses have low distortion and higher light sensitivity with F-stop ranging from f/1.4 to f/16 and in-focus distances from 3.28ft (1 meter) to infinity. The aperture of the lenses is set at F-stop of f/11 for a relatively large range of in-focus distance, with the downside of requiring brighter lighting. This F-stop is best suited for daylight activities. A focus distance exceeding 15m is selected on the lenses such that the manufacturer recommended in-focus distance range is from about 40ft (12.2m) to more than 110ft (33.5m). Details on the angle of view and measurement volume resulting from the selected lens parameters are presented in Section 3.1.1.

The two cameras are bolted to a hollow aluminum bar 30in. on center from each other and aligned for parallel fields of view. The cameras are enclosed in aluminum casings to protect them against tampering and accidental bumps. The casing is not watertight. It is essential to maintain the relative orientation and position between the cameras. Any relative movements between the cameras will invalidate the calibration and lead to errors in measurements.

3.1.2 Computer and PCIe Expansion Box

The cameras connect to a single laptop computer through a PCIe expansion box (Figure 3-2). The expansion box contains a specialized GigE acquisition card with two Ethernet ports. The box connects to the laptop through a Thunderbolt cable. The computer operates the software that triggers camera frame capture through the Ethernet ports. The computer has a primary Solid State Drive (SSD) where image capture should be directed. The SSD drive virtually eliminates image queuing when captured images are transferred to the drive during the acquisition process.



Figure 3-2: Laptop and PCIe expansion box

3.1.3 System Connectivity

Each camera has a power chord that plugs into a 110V outlet and an Ethernet chord. A minimum Ethernet cable rating of **CAT 5e** is necessary for the system to operate at full bandwidth. If Ethernet cables need to be replaced due to damage, the replacement cables for both cameras should be identical in specifications and length. The camera cables are already stress-relieved on the aluminum protection enclosures, such that tugging on them should not tug on the cameras.

Connection sequence:

- 1- Plug the PCIe expansion box into the laptop using the Thunderbolt cable and port.
- 2- Plug the camera Ethernet chords into the PCIe expansion box's Ethernet RJ45 ports (Figure 3-3). It is advised to stress-relieve the Ethernet cables prior to plugging them into the box by wrapping them around a fix object.
- 3- Plug the power cables of the cameras, the PCIe box, and laptop computer (if needed) into the power supply. To avoid accidental loss of power to the cameras, please ensure that the power cables are properly stress-relieved prior to plugging them into the power supply. This can be done by tying them to a table or other immovable object prior to plugging them into the power supply.

The cameras will turn on automatically when they receive power. The computer can now be powered up.



Figure 3-3: System connectivity for a Live Test

3.1.4 Power supply

A power supply is not provided with the system. Any stable pure sine-wave power supply that provides standard 110V 50/60hz power will work for the cameras and computer. The cameras consume at most 6.7 watts of power each, while the computer may draw up to 150 watts. The power supply should be able to deliver the peak power for the system components and the cumulative energy needed to complete a field test. Portable generators or batteries can be used. If artificial lighting is employed, a more powerful power supply may be required.

3.1.5 Supplied Optional Hardware

3.1.5.1 High-Contrast Physical Targets (HCPT)

While the CIV system can track most selected targets on a bridge surface, even with limited contrasting features, High-Contrast Physical Targets (HCPT) can be used to minimize noise in the measurements, focus measurements to clearly marked locations, or where sufficient contrasting features are not available. The CIV system is delivered with three sets of 40 HCPT. Each set has HCPT of 4x4in., 7x7in., or 10x10in. The HCPT are printed on matte white aluminum sheets and attached to an aluminum angle using double-sided heavy duty mounting tape (Figure 3-4).



Figure 3-4: Supplied High-Contrast Physical Targets (HCPT)

3.1.5.2 Extension Rod and Tape to Affix High-Contrast Physical Targets

To affix HCPT on the surface of a structure, double-sided tape is recommended. As can be seen in Figure 3-5, the tape can be attached to the target backside or the aluminum angle depending on the desired orientation with respect to the structure's surface. The supplied double-sided heavy duty mounting tape can securely attach a target to steel and concrete surfaces, while allowing the targets to be easily knocked off the surface without leaving any marks. While it is preferable to clean a surface from dust and debris with a rag before attaching physical targets, it may not be necessary in many cases as the provided mounting tape is able to attach the targets to concrete or steel surfaces with limited contamination.

In cases where the structure is elevated or difficult to reach by hand to affix targets, a supplied extension rod can be used. The targets can be attached lightly to the rod using double-sided tape of length that is shorter than the length of tape used on the target to attach it to the surface. This way, when the double-sided tape connects with the surface, the rod can be pulled away and the target remains attached to the surface. A 30ft (9.15 meters) extension rod and double-sided tape are supplied with the system.

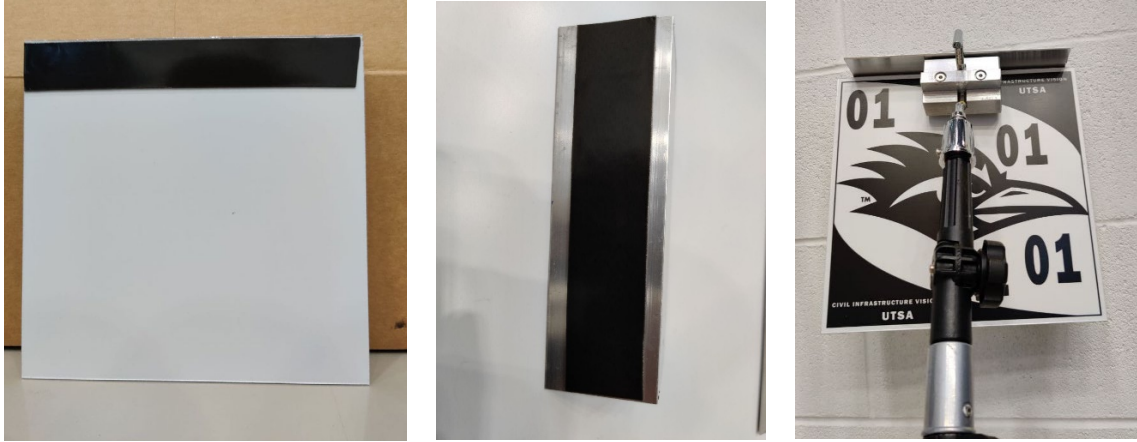

Figure 3-5: Double-sided tape on target and extension rod

3.1.6 Optional Hardware that is not Supplied

3.1.6.1 Flood Lights

Where lighting is low or varies significantly during a test (e.g., moving dark clouds), using flood lighting can help stabilize the light intensity on the area being monitored. It is preferable that the lights produce even lighting over the surface being monitored as opposed to using spot lighting.

Flood lights are not provided as part of the system. Any field lighting can be used. If halogen lights or lights that produce significant heat are used, it is advised to place them to the sides for the field of view such that the rising heat ripples do not introduce noise in the readings.

3.1.6.2 Laser Distance-Measuring Device

When identifying the optimal location to place cameras for monitoring a structure, knowing the range of distances from various points on the structure to the cameras is useful (Section 4.1) A laser distance-measuring device or tape measures can be used.

3.2 SOFTWARE

In this section, the components of the CIV software system are described. Additionally, the automatic output folder structure generated by the software for each project is described. The types and storage locations of all output files that can be generated by the various modules of the software are also presented.

3.2.1 Software Components

The CIV software is developed in the LabVIEW 2018 environment. For the user to run the application, the LabVIEW Run-Time engine 2018, Vision Development Module Run-Time 2018, and Vision Acquisition Software 2018 are installed and licensed on the computer.

The CIV software consists of one executable file that is compiled to only run on the provided computer. The **CIVBRIDGE.exe** application is located on the desktop of the computer. The CIV system is delivered pre-calibrated and the factory calibration files are provided on the desktop under a folder with the name **“CIV Bridge Factory Calibration <DATE>”**.

The CIV software has two main modules, the Live Test module and the Post-Processing module. In the Live Test Module, the user can acquire images from the cameras and save the spatial coordinates of selected targets the user can also plot live the movements of select target to monitor the progress of a test. The plots generated during a Live Test will be saved automatically at the end of the test. In the Post-Processing module the user can re-process images and target data saved during a Live Test to generate additional target locations, smooth target data and calculate relative movements and strain between targets.

Both the Live Test and Post-Processing modules generate a folder structure under the parent folder that is selected by the user. These folder structures and the output files generated by the various software modules are described in more detail in Chapters 4 and 5.

4 RUNNING A LIVE TEST

In this chapter, step-by-step instructions are provided for using the Live Test module. As outlined in Section 3.2, the Live Test module allows acquiring images of a structure during a monitoring period, from which the three-dimensional spatial movements of targets can be obtained over that monitoring period. The Live Test module allows the user to select targets on the structure surface prior to starting image acquisition for monitoring live during acquisition. The module also allows to plot live the movements of selected targets.

Guidance is also provided in this chapter regarding setting up a Live Test, including selecting the most optimal location for the cameras with respect to a structure, the best camera settings, as well as how to select targets that can be tracked reliably by the CIV software.

4.1 Initial Camera Positioning

Several factors need to be considered when selecting the location of the cameras with respect to the structure that is to be monitored. This section outlines key considerations for initial camera positioning. Once the software is turned on and the user can see the images produced by the cameras, further adjustments to the positioning can be performed to capture the desired field of view (FoV).

4.1.1 Measurement Volume (MV)

Cameras need to be placed such that the entire region of the structure that needs to be monitored lies within the Measurement Volume of the system. The measurement volume (MV) of the CIV system is the volume within which the system is calibrated and can achieve the specified measurement accuracy. The MV is related to the field of view of the cameras, as well as the selected lens aperture and focus distance. The field of view of a camera (horizontal and vertical viewable area) is directly proportional to the measurement distance (D) as well as the lens angles of view (Table 4-1, Figure 4-1).

Table 4-1: Viewing angles for CIV Bridge camera lenses

Lens Focal Distance	Diagonal Viewing Angle (DVA)	Horizontal Viewing Angle (HVA)	Vertical Viewing Angle (VVA)
85mm Lens	29°	24°	16°

As mentioned in the Hardware Section 3.1, the 85mm fixed focal-length lenses of the CIV system are set to a F-stop value of f/11 and a focus larger than 49.2ft (15 meters). These settings bound the measurement volume between the measurement distances of 40ft (12.2 meters) and 110ft (33.52 meters) (Figure 4-1). The measurement volume horizontal dimension at a particular distance can be calculated by taking the camera Horizontal Field of View (HFV) at that distance and subtracting from it the distance between the cameras, which is 2.5ft (0.762m) (Figure 4-1). The vertical dimension of the MV is equal to the camera Vertical Field of View at any given distance. Table 4-2 presents the MV horizontal and vertical dimensions at various measurement distances.

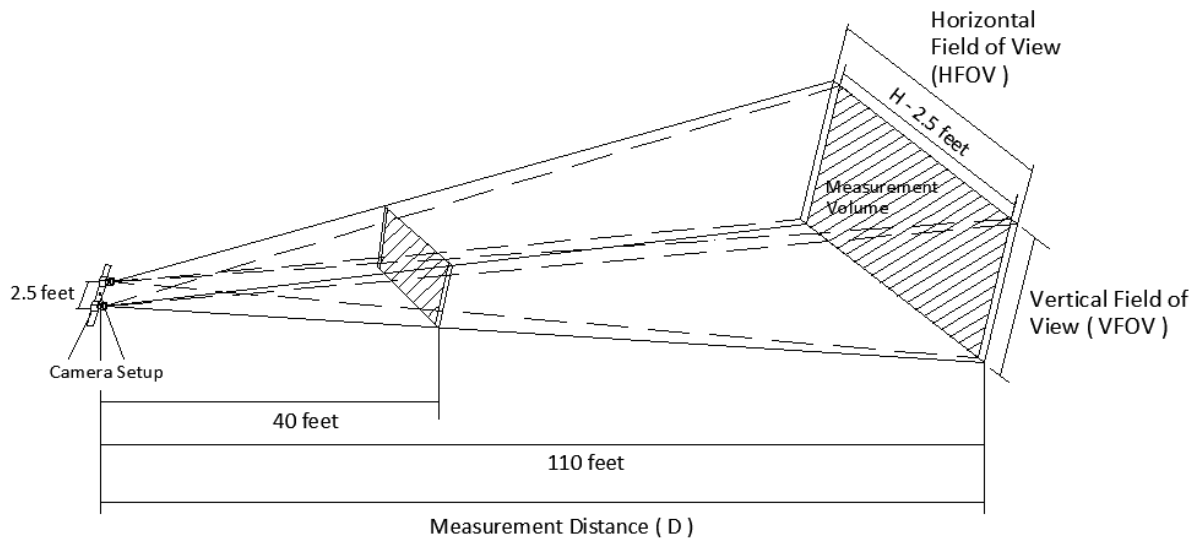

Figure 4-1: Fields of view and the measurement volume of the CIV Bridge system

Table 4-2: Measurement volume dimensions

Measurement Distance (D)	Measurement Volume	
	Horizontal Field of View (HFOV)	Vertical Field of View (VFOV)
40ft	17ft	11.24ft
75ft	31.88ft	21ft
110ft	46.75ft	30.91ft

4.1.2 Wind and Vibrations

Vibrations of a structure and the cameras can blur captured images and lead to increased noise in the measurement data. Camera vibration can be minimized by using a stiff tripod, setting the

cameras on a surface with limited vibrations (e.g., away from truck induced vibrations, or on solid ground as opposed to on a bridge or other structure), as well as sheltering the cameras from wind or avoiding windy days altogether.

4.1.3 Lighting Considerations

Cameras should not be faced directly into the sun to avoid reflection and glare issues. If it is unavoidable that the cameras should face in the general direction of the sun, a shade shield could be used to shade the cameras lenses from the sun to help improve glare issues.

4.2 Targets and Target Tracking Considerations

Targets within the DIC vernacular are not physical objects but rather sub-images within a camera image. The movements of targets are tracked by the system between successive images. As such, targets can be selected on any surface that has contrasting patterns. Alternatively, targets can be selected to capture High-Contrast Physical Targets (HCPT) attached to a surface. As described in Section 2.2, the CIV DIC system determines the 3-D spatial coordinates of selected targets by transforming pixel coordinates of target sub-images into real world coordinates through triangulation. Accuracy and noise levels in the 3D spatial location of targets depends on the quality of the selected targets. The following sub-sections discuss best-practices for selecting targets to achieve optimal tracking.

4.2.1 Target Size

The size of a DIC target is given in pixels. This pixel size translates into real-world dimensions based on the camera field of view. The CIV cameras have 31.4 megapixel sensors with 6480(Horizontal) x 4860(Vertical) pixels. For example, the horizontal and vertical dimensions of the field of view at a distance of 40ft (12.2m) are 17ft and 11.24ft respectively. Therefore, for a target size of 100 x 100 pixels, the physical dimensions of the target at 40 ft (12.2 meters) would be about 3.10 x 3.10 in.; if the target surface is perpendicular to the camera line of sight.

During the development of the CIV system, the tracking stability and measurement noise for targets of various sizes were explored. The trial sizes ranged from 30x30 pixels to 120x120 pixels. Optimal results were achieved with a target size of 100x100 pixels. As the targets got smaller than that optimal size, measurement noise increased and the chance of the system losing the targets increased (tracking stability). Reading noise and tracking stability were acceptable down to a target size of 60x60 pixels. The quality of readings deteriorates rapidly below this target size of 60x60 pixels. Using larger target sizes than the optimal size did not improve the quality of the readings. On the other hand, larger targets have a higher chance of intercepting cracks and other transient features that can result in misleading data. Target sizes more than 100x100 pixels are therefore not recommended in most applications.

The physical dimensions corresponding to targets ranging from 60x60 pixels to 100x100 pixels are presented for various distances from the cameras in Table 4-3. This table is useful in selecting the appropriate HCPT size to attach to a structure for monitoring.

Table 4-3: Physical dimensions of targets of various pixel sizes at different measurement distances

Measurement Distance (D)	HFOV	VFOV	Physical dimensions for a 60x60pixel target (in.)	Physical dimensions for a 100x100pixel target (in.)	Recommended physical dimensions for a 100x 100pixel HCPT
	= 0.425 D	= 0.28 D			
40ft	17ft	11.24ft	1.9 x 1.9	3.1 x 3.1	4 x 4
75ft	31.88ft	21ft	3.6 x 3.6	5.9 x 5.9	7 x 7
110ft	46.75ft	30.91ft	5.2 x 5.2	8.7 x 8.7	10 x 10

4.2.2 Target Quality

In addition to target size, the amount of contrasting features on a target, or target quality, influences measurement noise and tracking stability. The DIC algorithm used in the CIV system is robust with respect to target quality. Nevertheless, it does still require a minimal amount of contrasting features to track targets reliably. In validation tests of the system, uniform low-contrast surfaces could be tracked reliably with as little as one chalk line drawn on them: regardless of the line's shape or inclination (Figure 4-2).

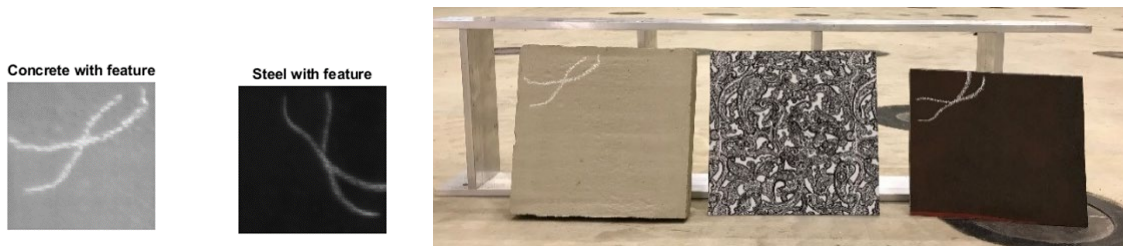

Figure 4-2 Example surface markings on concrete and steel surfaces that can be tracked reliably by the CIV system

Typically, older structures have surfaces with sufficient defects and imperfections to permit the CIV system to track them reliably. In rare cases where a surface needing to be monitored has almost no features (e.g., a white painted wall), the user can either add single line markings on the surface where the targets will be selected or attach the supplied High-Contrast Physical Targets (HCPT, Figure 3-4). Removable or washable markings can be applied such as chalk lines, as long as they are stable during the monitoring process.

To aid the user in determining the quality of a selected target, a match score is presented to the user during the target selection process (4.3.6). The match score ranges from 0 to 1000 and is frequently above 950 for typical surfaces on structures. A minimum match score value of 750 is recommended to maximize reliable target tracking. The user is advised to select targets with a match score of at least 750 and preferably greater than 900.

4.2.3 Target Stability

Target stability refers to the ability of a target to retain its shape and appearance during a monitoring project. It is essential to select targets that do not change in appearance during a monitoring project. Such changes can occur due the generation of new cracks or extension of existing cracks, delamination of concrete or paint from a surface, wetting or drying of a surface, or in the case of long-term monitoring projects, discoloration or staining from water or other sources. Since the system tries to find the same target sub-image in all subsequent images, changes to a target's appearance can result in the loss of the target by the system.

4.2.4 Lighting Considerations

Dramatic changes in lighting conditions during a Live Test alter the appearance of a target, which can result in loss of the target by the system or a perception of artificial movement of the target. The DIC algorithm used in CIV was designed to be robust with respect to lighting changes for this reason. In a validation experiment for the CIV system, smooth concrete and steel surfaces with minimal contrast (single chalk line), as well as HCPT were tracked through lighting changes from direct sunlight, through partial shade, to full shade (Figure 4-3). These experiments were intended to bracket anticipated lighting variations that can occur when clouds alter lighting on a structure. The sensitivity study demonstrated that the CIV system does not lose targets if cloud conditions change, even if they do so drastically during a test. However, in the more extreme scenario of going from full light to full shade, perceived target artificial movements were noted to be on the order of a few thousandths of an inch in the plane of the cameras and a few hundredths of an inch in the out-of-plane direction at a measurement distance of 30ft (Figure 4-4). Such artificial target drifts are typically well within the desired measurement tolerance for structural deformations; however, they may influence strain values undesirably. It is therefore always preferred to run tests where the lighting does not change significantly on targets (e.g., from full sun to full shade). In rare cases where significant lighting changes cannot be avoided, it is advisable to use flood lighting on the surfaces to be tracked, such that the artificial light intensity dwarfs the natural changes in lighting that are expected. In cases where light variations are inevitable, it is also advisable to use targets with a high match score and high contrast levels (e.g., white on black of HCPT). This is because such targets suffer less light shift than targets with lower contrasts.

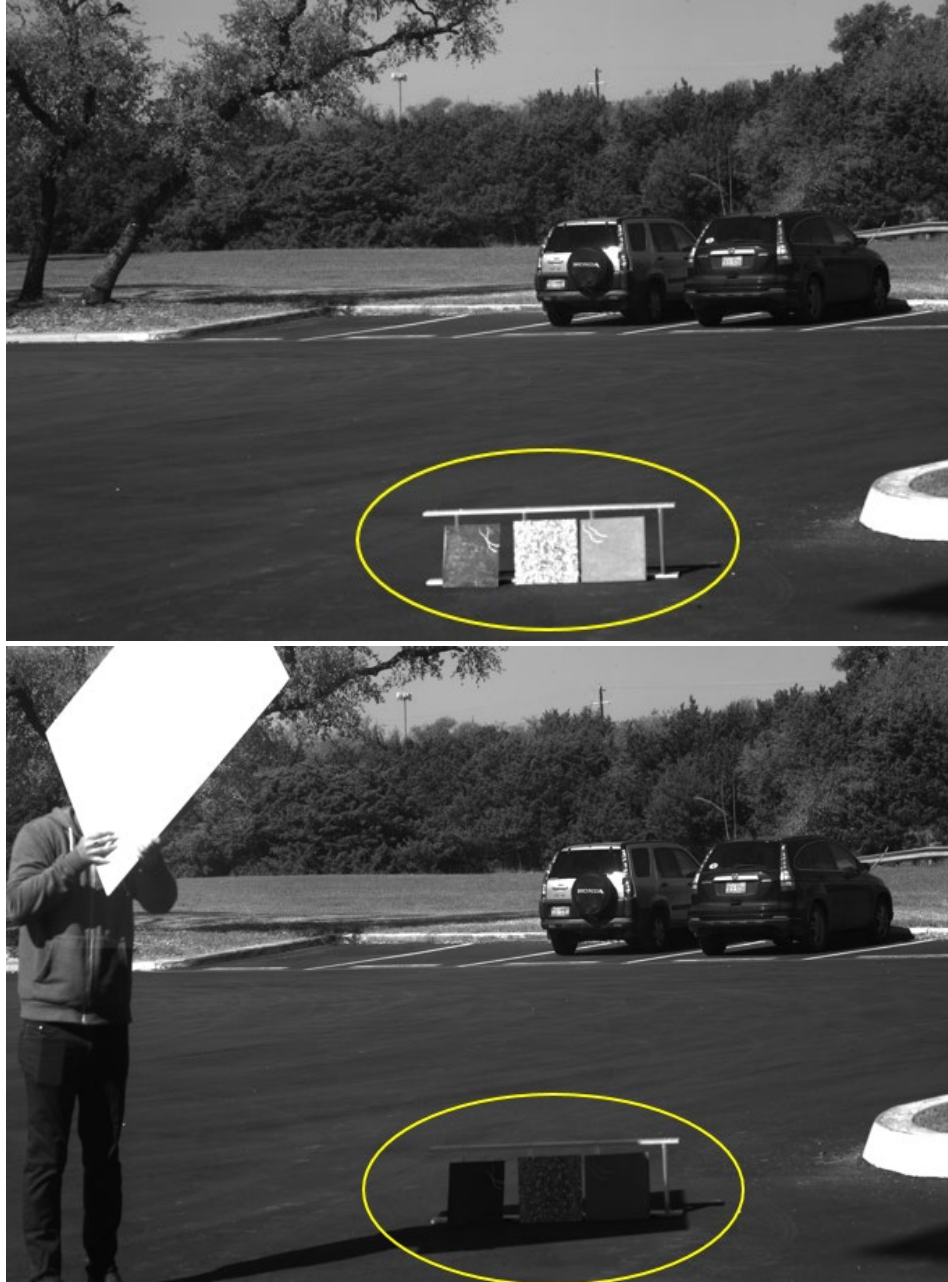

Figure 4-3 Targets under direct sunlight (top) and targets under shade (bottom)

Figure 4-4 illustrate a shift in the location data obtained from the system due to lighting changes. For this test, the targets and the cameras were not moved but only the lighting condition on the targets was altered as illustrated in Figure 4-3. The location data reported in the figure were calculated as an average of the target location under a given lighting condition. The plot illustrates the scale of the target perceived movement due to lighting changes in each successive frame in the X and Y (in plane) and Z (out-of-plane) directions.

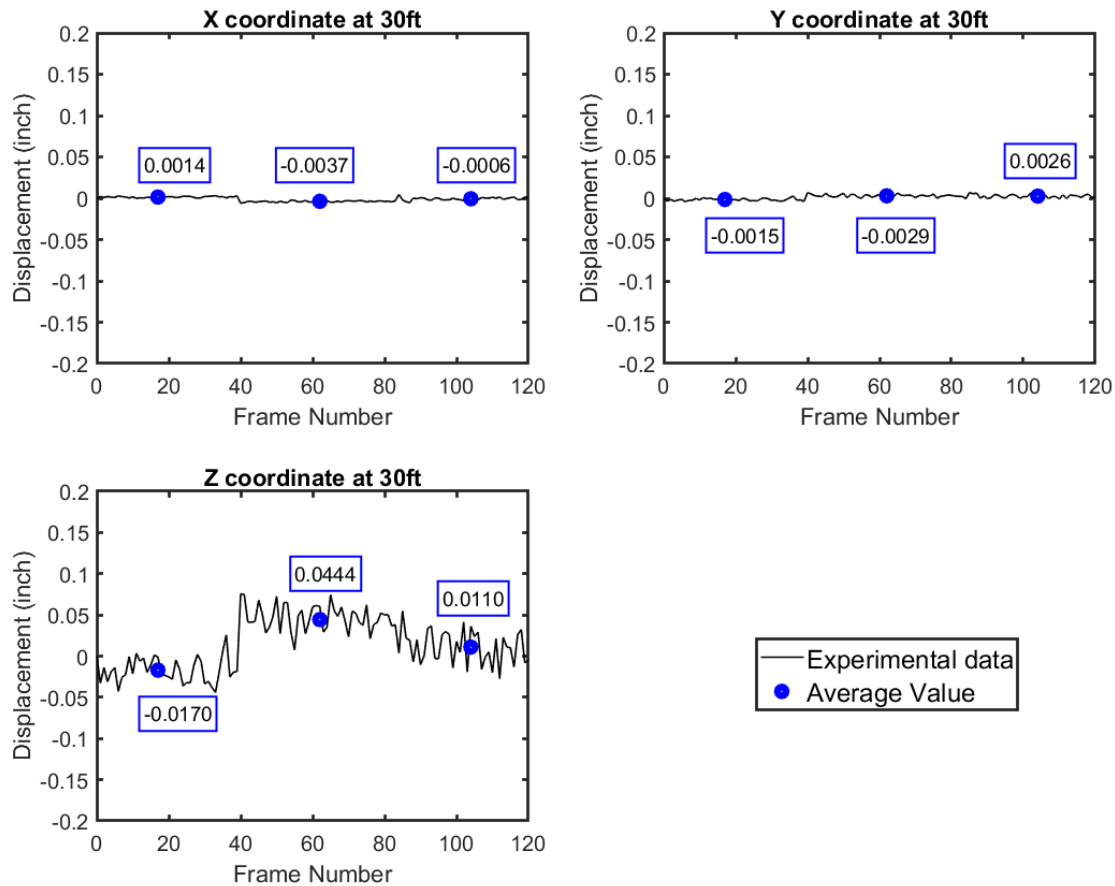

Figure 4-4 Shift in target location due to lighting variation at 30ft using 100x100 pixel HCPT

In summary:

- Target location depends on DIC perception of features in the target.
- Lighting variations during a test can generate fictitious movement of targets.
- CIV algorithms are robust with respect to light variations but it is better to avoid them. If light variations are expected (moving clouds), HCPT are best since black on white contrast minimizes light shifts.

4.3 Running a Live Test using the Live Test Module

After the cameras are placed in their initial position based on guidelines provided in Section 4.1, they should be connected to the power source and the computer as described in Section 3.1.3. If High-Contract Physical Targets (HCPT) are desired, they should be attached at the desired locations on the structure's surfaces per Section 3.1.5.

The main functions involved in running a Live Test consist of:

- 1- finalizing the camera positioning

- 2- setting cameras exposure time and frame rate,
- 3- selecting targets within the camera field of view (if desired),
- 4- defining live plots for target movements that update during the test (if desired), and
- 5- acquiring images and data for the duration that the structure is to be monitored.

4.3.1 Main Menu

After running the CIV executable file, the first screen that appears for a few seconds contains the CIV software version details. Then the **Main Menu** screen appears as shown in Figure 4-5. The software consists of two main modules that are used for various applications. On the **Main Menu** screen, a button is placed for each of these modules: the Live Test module, and the Post-Processing module. Each module will guide the user through a series of screens with various functions to accomplish the module tasks. At the bottom of each screen of a module, navigation buttons are provided as shown in Figure 4-6. The **Previous Screen** and **Next Screen** arrow buttons can be clicked to navigate to the previous or next screen when permitted. In some case, the **Previous Screen** button may be disabled to prevent backtracking that can result in loss of prior selections. Below these buttons, the **Exit Module** button can be used to terminate the module and return the user to the **Main Menu** screen.

Within any screen, the user can exit the program by pressing the “X” button at the top right of the screen (Figure 4-5). This action will immediately terminate any ongoing processes and close the software. Any data or images not saved on the hard drive at that stage will be lost.

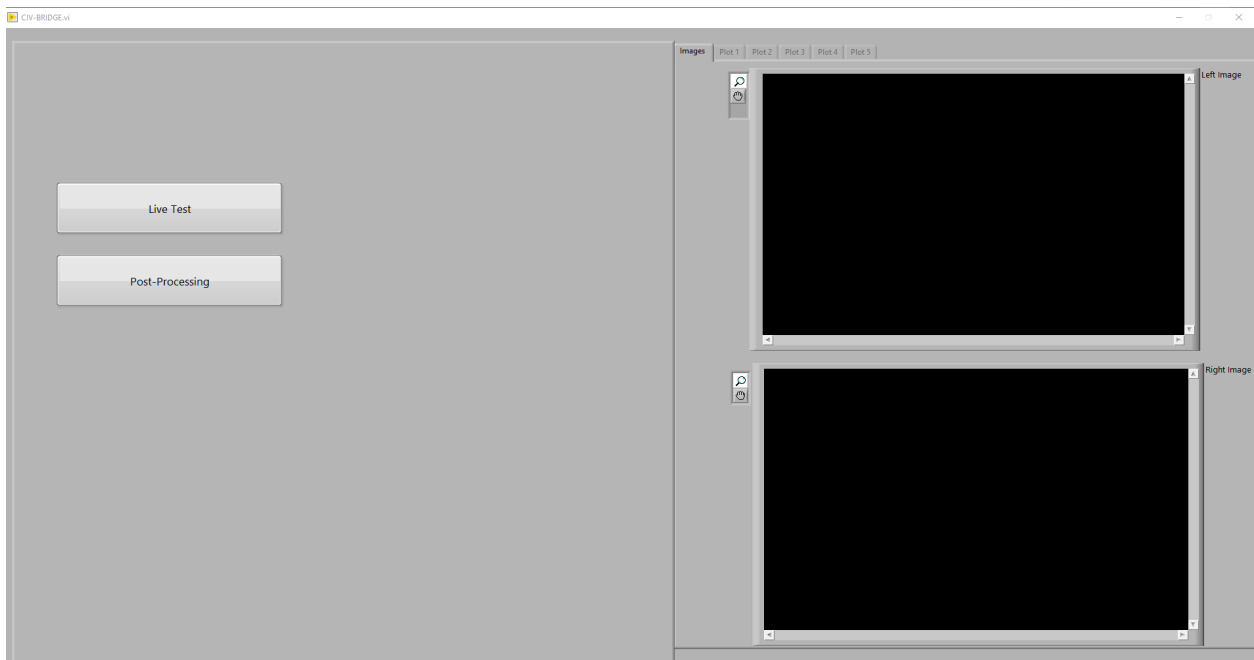

Figure 4-5: **Main Menu** screen

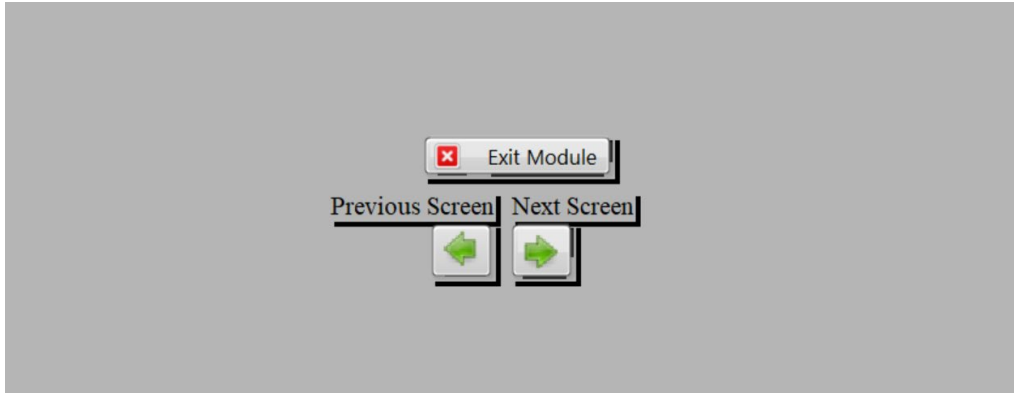

Figure 4-6: Navigation buttons within each module screen

To start the Live Test Module, click the **Live Test** button.

4.3.2 Camera Detection

The first screen that appears is the **Camera Detection** screen. Click on the **Search for Cameras** button to start the camera detection process. Once the cameras are detected, the two circular markers will turn on and change color. If the cameras are not detected, the markers will remain dark green. If that occurs, make sure the cameras are connected to the computer and powered per Section 3.1.3.

Once the cameras are detected, **Next Screen** will be enabled. Click the button to proceed.



Figure 4-7: **Camera Detection** screen showing dark green markers (top) when the cameras are not detected and light green (bottom) when they are detected.

4.3.3 Project Data

The following screen is the **Project Data** screen as shown in Figure 4-8. In this screen, the user is asked to enter a name for the project folder and specify a parent directory where the project folder will be automatically created. If desired, representative GPS coordinates for the project location can be added, as well the focus distance and aperture of the camera lenses. All provided

information is reproduced at the beginning of all the output files. A folder with the project name specified by the user will be created and all the output files produced in the future steps will be saved within this folder.

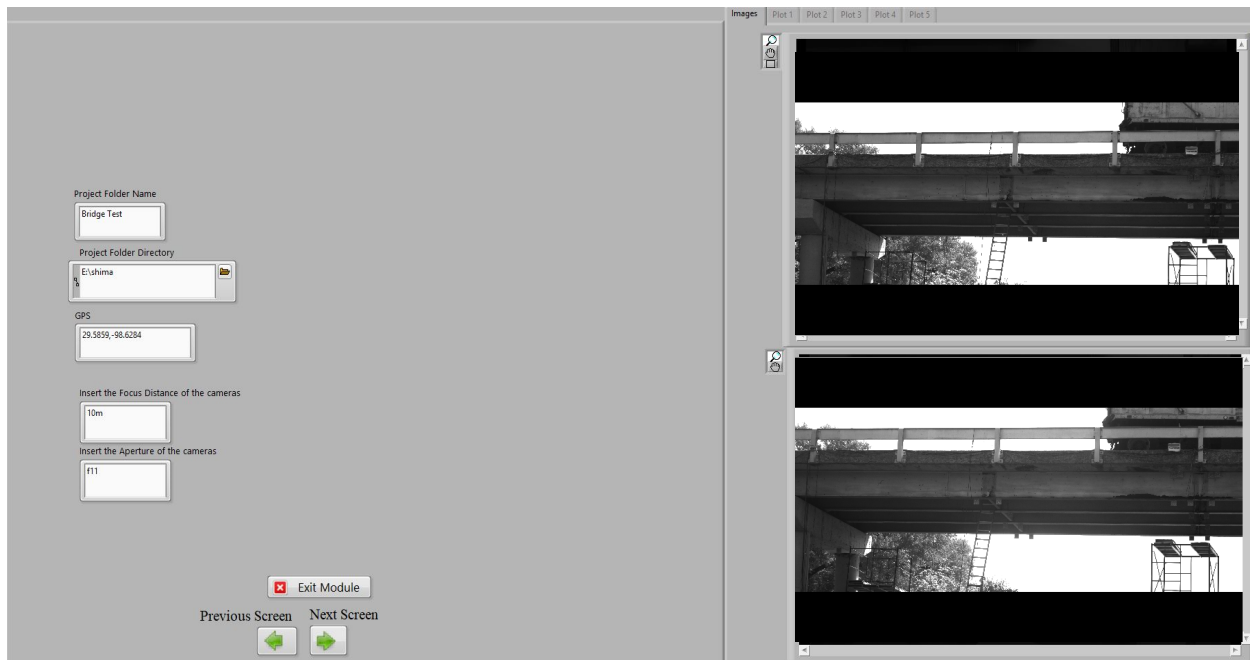

Figure 4-8: **Project Data** screen

4.3.4 Camera Setup

The following screen is the **Camera Setup** screen (Figure 4-9). In this screen, there is a button that turns on and off the cameras. Prior to turning on the cameras, the region of interest (ROI) and shutter speed for image acquisition can be set. Once the cameras properties are input, the cameras can be turned on to see live what the cameras are capturing and check the field of view and the brightness of the images. When the cameras are turned on, the camera settings cannot be modified. To adjust camera settings, the cameras must be turned off again.

The Region of Interest (ROI) can be set to focus only on the region of the field of view that needs to be monitored. This feature effectively truncates the images being captured, making their file sizes smaller and allowing for faster acquisition frame rates. The fastest frame rate at full resolution of the CIV Bridge cameras is 3.75 frames per second (fps). By decreasing the ROI, the frame rate can be increased up to 17fps. With the cameras turned on, the left and right camera images are shown on this screen as acquired live by the cameras. Adjustments to the position of the cameras can then be made to obtain the desired fields of view. **Make sure that both cameras can see the full region of interest that needs to be monitored on the structure.**

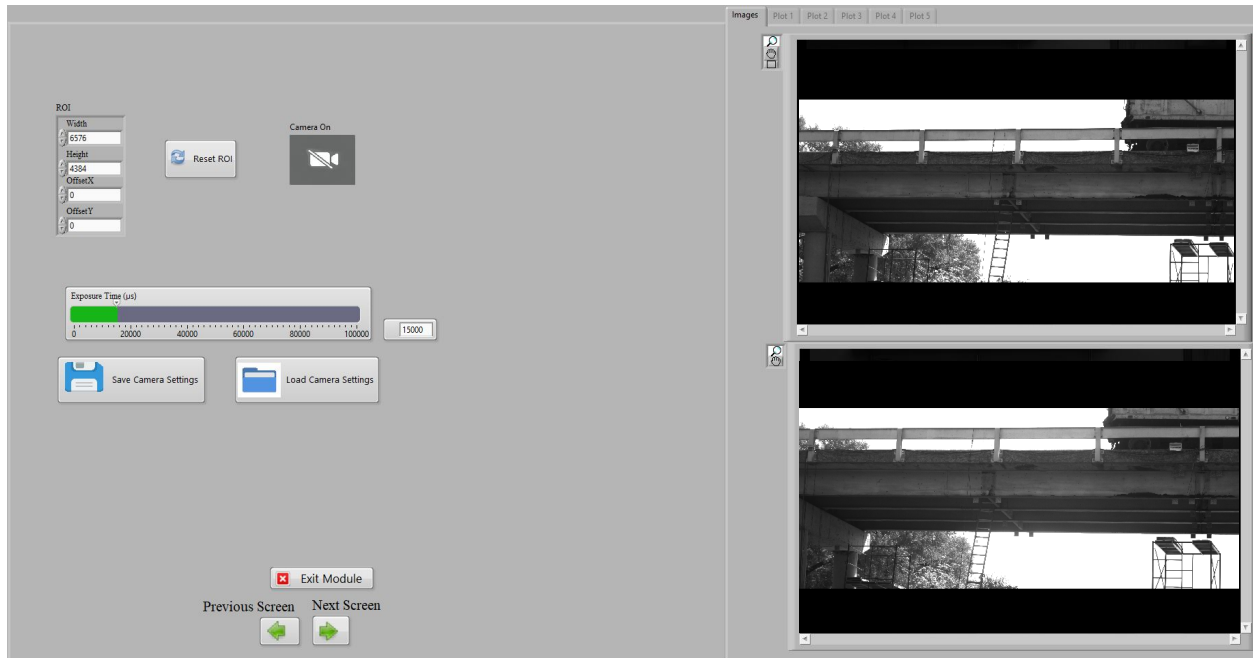

Figure 4-9: **Camera Setup** screen

On the same screen, the exposure time for image acquisition can be set (Figure 4-9). Exposure time is the time during which light falls onto the image sensor of a digital camera. To mitigate against blurred images due to vibrations of the cameras or the structure being monitored, **the shortest practical exposure time should always be targeted. Ideally, exposure times should not exceed 15,000 microseconds (μs)**. However, as exposure times get shorter, images will get darker as less light reached the camera sensors. Since the camera sensors and the CIV system are far more sensitive than the human eye, selecting an exposure time that results in what can be considered to be a dark image photographically, does not hinder system performance and is recommended. The user should select the shortest exposure time that will generate as dark of an image as practical, while still allowing them to see the structure and targets reasonably well. On a sunny day and for exposed structures, it should not be an issue to use a shorter exposure time than the recommend maximum. However, in darker conditions or for sheltered structures, it may be challenging to do so without artificial lighting. In such cases, if the structure and camera vibrations are relatively low, the user can attempt using longer exposure times than the maximum recommended value, or alternatively, opt to use artificial flood lighting to maintain a short exposure time.

It is recommended to save the camera settings before moving to the next screen. The **Save Camera Settings** button will automatically save the camera setup into the project folder. User can always load and use the camera settings of previous test.

4.3.5 Load calibration

The following screen is the **Calibration** screen. In this screen, the user is asked to provide the location of the calibration files to load. The CIV system is pre-calibrated and delivered with an initial calibration folder and files as described in Section 3.2. The **Calibration Validation Manual** explains how to verify that a calibration is still within the user error tolerance. If re-calibration is necessary, please contact your vendor. To load a calibration, click on the **Load Calibration Files** button as shown in Figure 4-10. A dialog box appears that allows the user to locate and select the folder where the previously saved calibration files are saved (Figure 4-11).

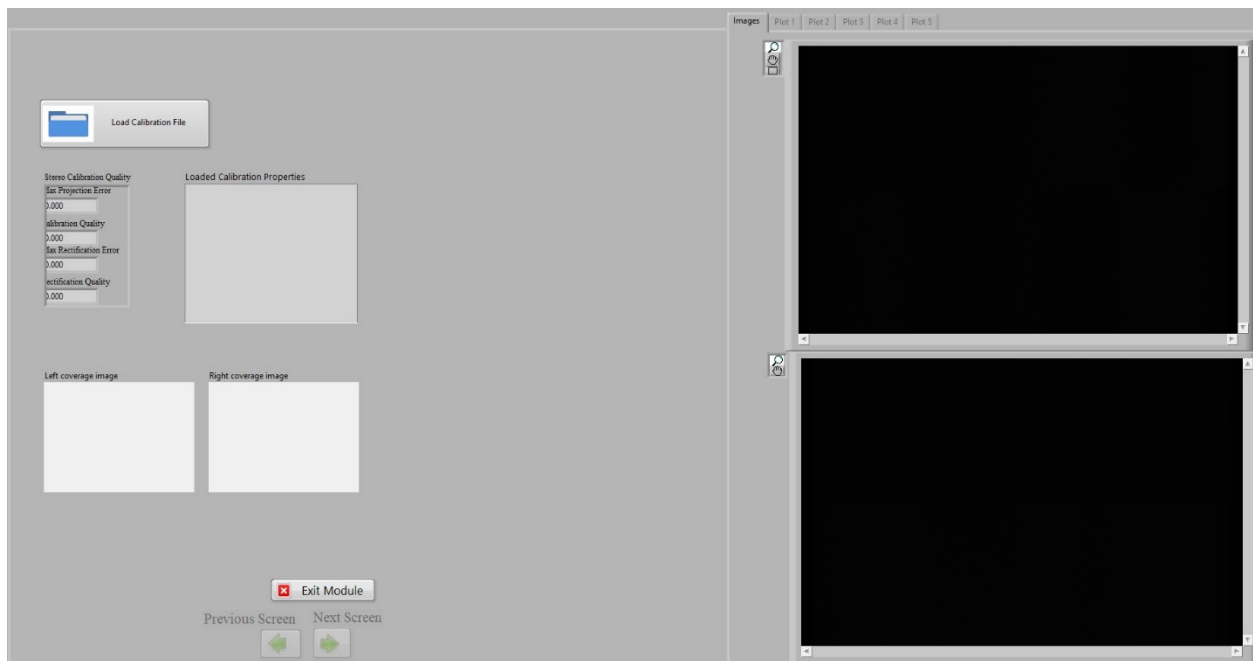

Figure 4-10: **Calibration** screen

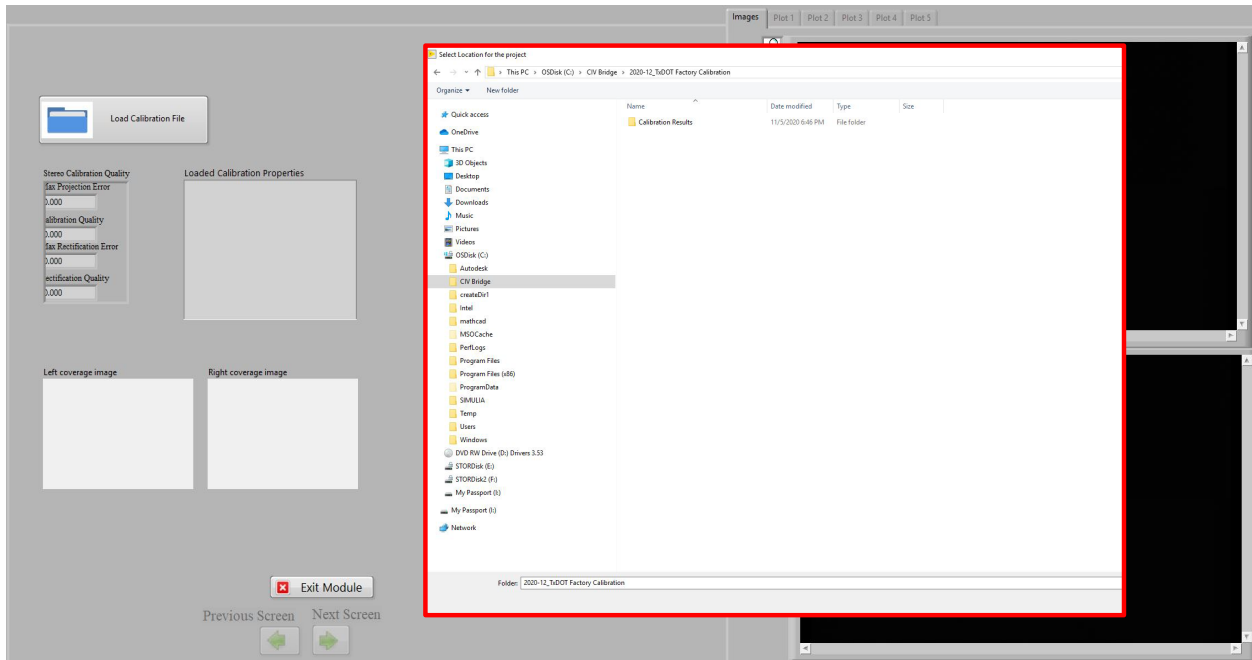

Figure 4-11: Dialog box for selecting the folder in which the calibration files are saved

Once the calibration is loaded, key calibration properties can be seen on the screen as shown in Figure 4-12. The name of the calibration and its details will be reproduced at the beginning of all the output files generated by the Live Test module.

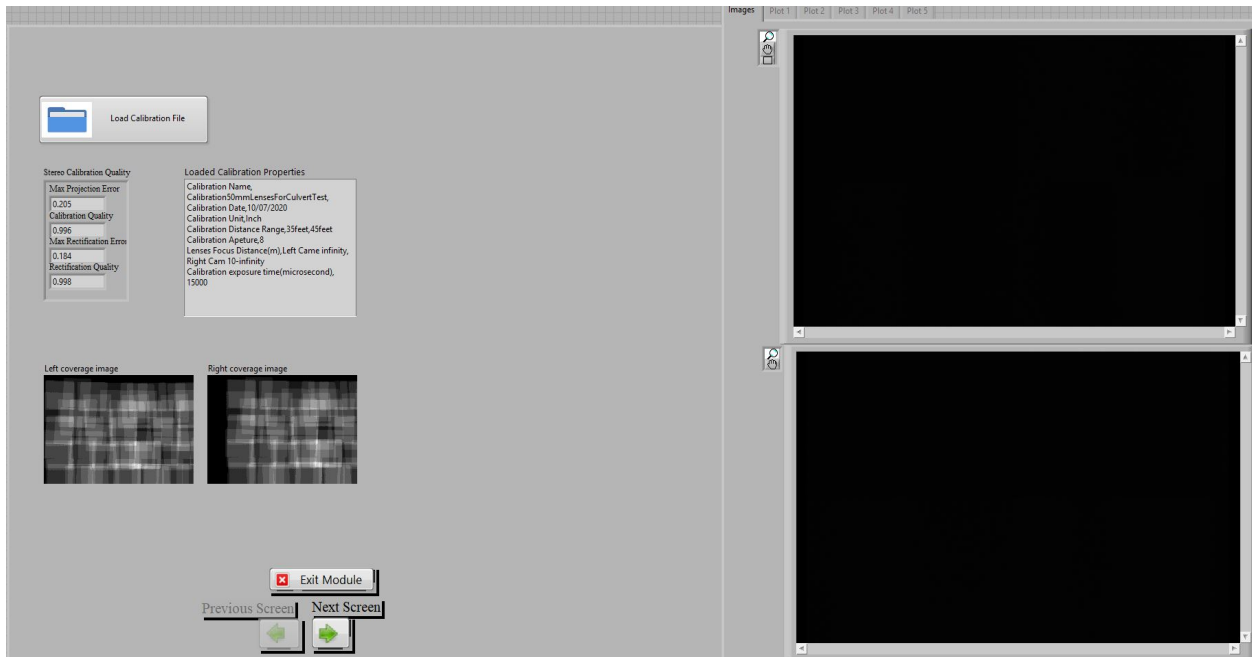

Figure 4-12: Sample key properties of the loaded calibration

4.3.6 Target Selection

The following screen is the **Target Selection** screen (Figure 4-13). The user is referred to Section 4.2 for guidance on selecting high-quality targets that can be tracked reliably by the software. While selecting targets to be tracked live during a test is optional, it is highly recommended that targets be selected and monitored at least at a few key locations on the structure. Tracking targets during a test provides a means to verify if the data being collected is correct and if targets can be tracked reliably from the images being acquired.

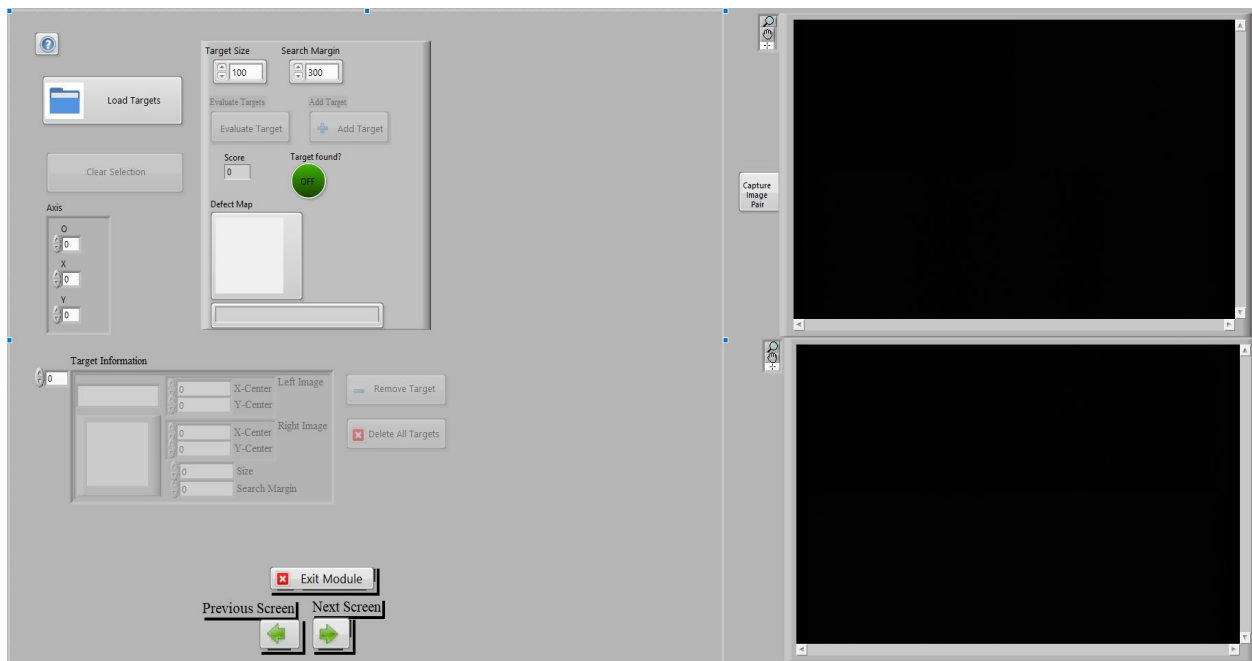

Figure 4-13: **Target Selection** screen

4.3.6.1 Target selection process

As a first step, a pair of images needs to be captured by clicking on the **Capture Image Pair** button. These images, one from each camera, will remain static during the target selection process, but can be refreshed by clicking the **Capture Image Pair** button again.

Each target is then selected in sequence through the following steps:

- 1- Select the target size: Target size is shown at the top of the screen and can be adjusted for each target created. As discussed in Section 4.2.1, it is recommended to leave the target size at 100x100pixels, if possible.
- 2- Pick a target (sub-image) on the Left camera image: The **Zoom** button and **Pan** button can be used to navigate the image for more accurate target selection (Figure 4-14). Double click anywhere on the image to zoom back out to the full image. Use the **Target Selection** button to select the target in the image. If using high-contrast physical targets

(HCPT), ensure that the selected target is entirely on the HCPT and does not capture parts of the underlying surface. Similarly, ensure that the target is selected on a single body that is not expected to change in appearance or size during monitoring (e.g., not at locations where cracks may occur or expand).

- 3- After a target is selected in the Left camera image, move the search window in the Right camera image to locate the same sub-image in that image (Figure 4-15). The **Zoom** and **Pan** buttons can also be used.



Figure 4-14: Selecting a target in the Left camera image



Figure 4-15: Moving the search window to locate the same target in the Right camera image

- 4- After the Left image target is selected and the search window is placed at the desired location, the **Evaluate Target** button should be clicked to evaluate the target quality. If a nearly identical target (sub-image) is detected in the Right Camera image as was

selected in the Left Camera image, a target pair is found. The **Target Found** button will turn on as shown in Figure 4-16. The **Match Score** number ranks the match results on a scale of 700 to 1000, where 700 equals the minimum score required for a target to be found and 1000 equals a perfect match. As discussed in Section 4.2, a match score above 900 is recommended for optimal target tracking. A match score below 750 is not recommended. The match score indicates how closely the Right Camera target matches the Left Camera target. This score is also affected by the level of contrasting features in the targets. If the targets have very limited features, the DIC software will have a harder time identifying them or identifying that they are similar. The **Defect Map** also shows the contrasting features in the target selected.

If a nearly identical target is not detected in the Right Camera image, the **Target Found** light does not turn on, the **score number** is empty, and the **Add Target** button remains disabled. The above target selection process must be repeated with a different target.

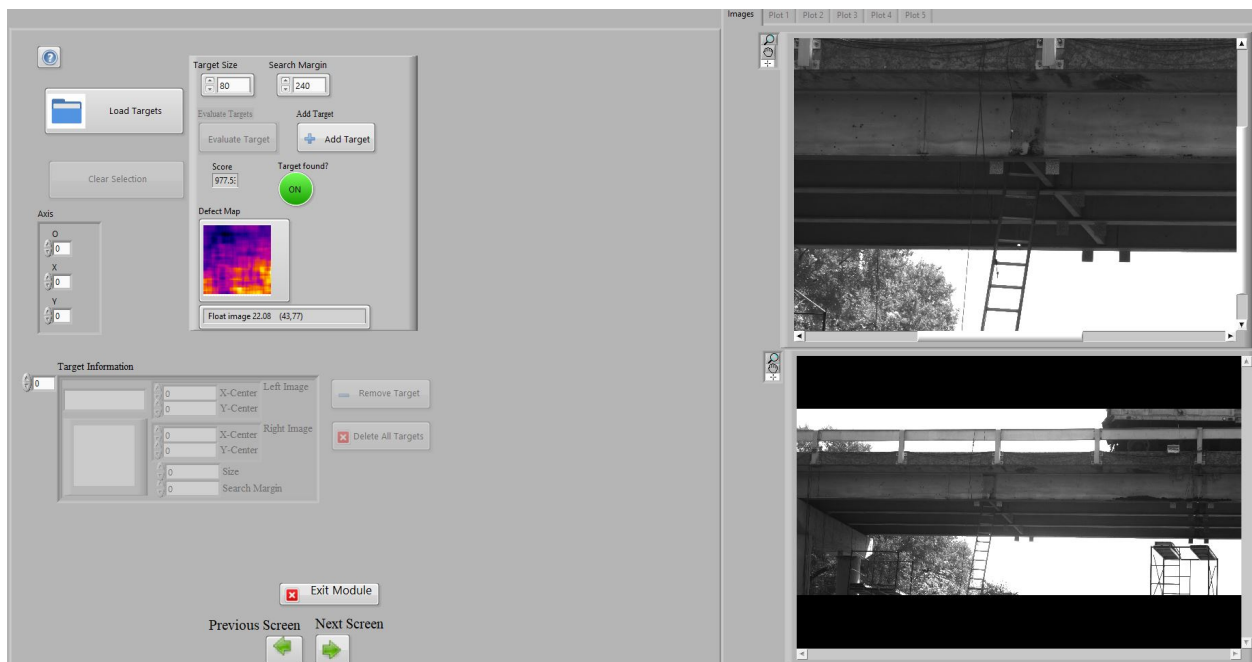

Figure 4-16 Evaluated Target result

- 5- Once a target pair is found and evaluated, the user can click on **Add Target** to commit the target to system memory. If a target pair is erroneously added, the **Remove Target** button can be used to delete a target from the **Target Information** list (Figure 4-17). The user must select the appropriate target number in the index box (Figure 4-17) that is to be deleted from the list and then click on the **Remove Target** button. The **Delete All**

Targets option is also provided if the user wants to delete all the targets selected and reselect again.

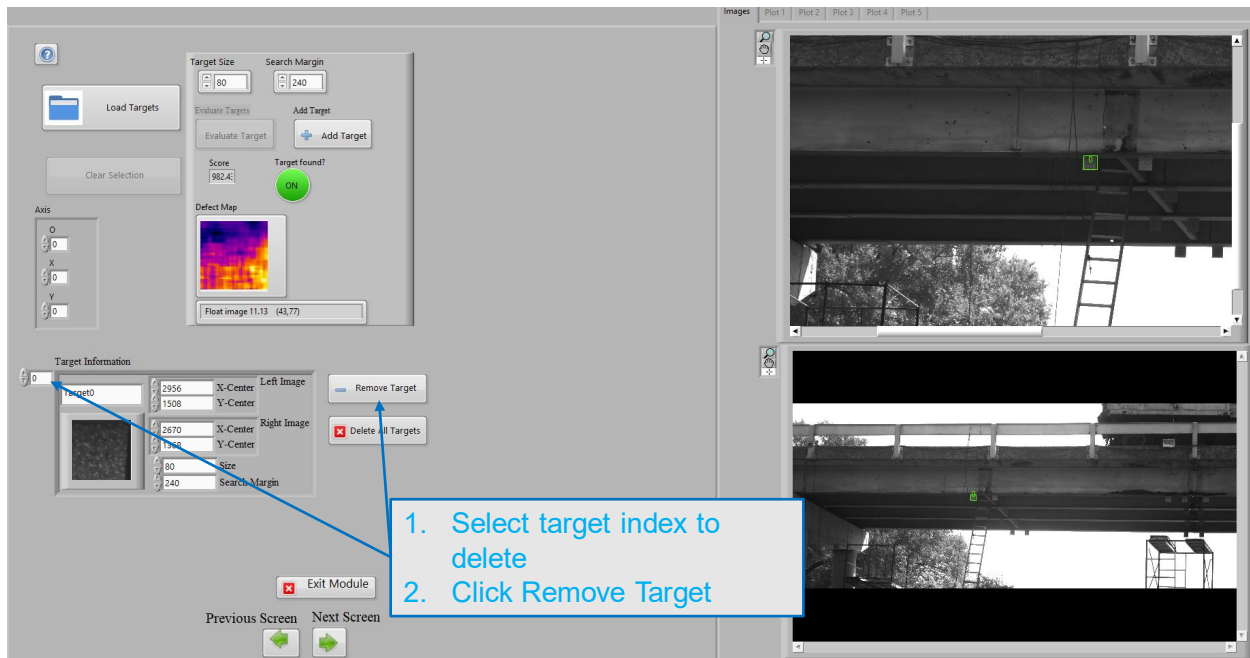

Figure 4-17: Created targets seen on the images of test specimen from both cameras

Repeat the target selection process described above to create all the targets that need to be monitored during the live test.

4.3.6.2 Selecting a user reference axis system

By default, the CIV system delivers the 3D spatial locations of targets in a coordinate system centered at the Left Camera sensor. The Z direction for that coordinate system is aligned with the line of sight, while the X and Y axes are lined up with the camera sensor. A user-defined reference coordinate axis can also be selected based on the selected targets. For example, in Figure 4-18, target 8 is selected as the origin, target 11 defines the alignment of the X axis, and target 9 defines the Y axis of the user coordinate system. The user needs to select the number of the targets for defining the axis and input them in the **Axis** box (Figure 4-18). The system then uses the selected targets to generate an orthogonal axis system that best matches the selected targets. If a user coordinate axis system is selected, the CIV system will deliver 3D spatial locations of targets in that coordinate axis system, in addition to the Left Camera axis coordinates.

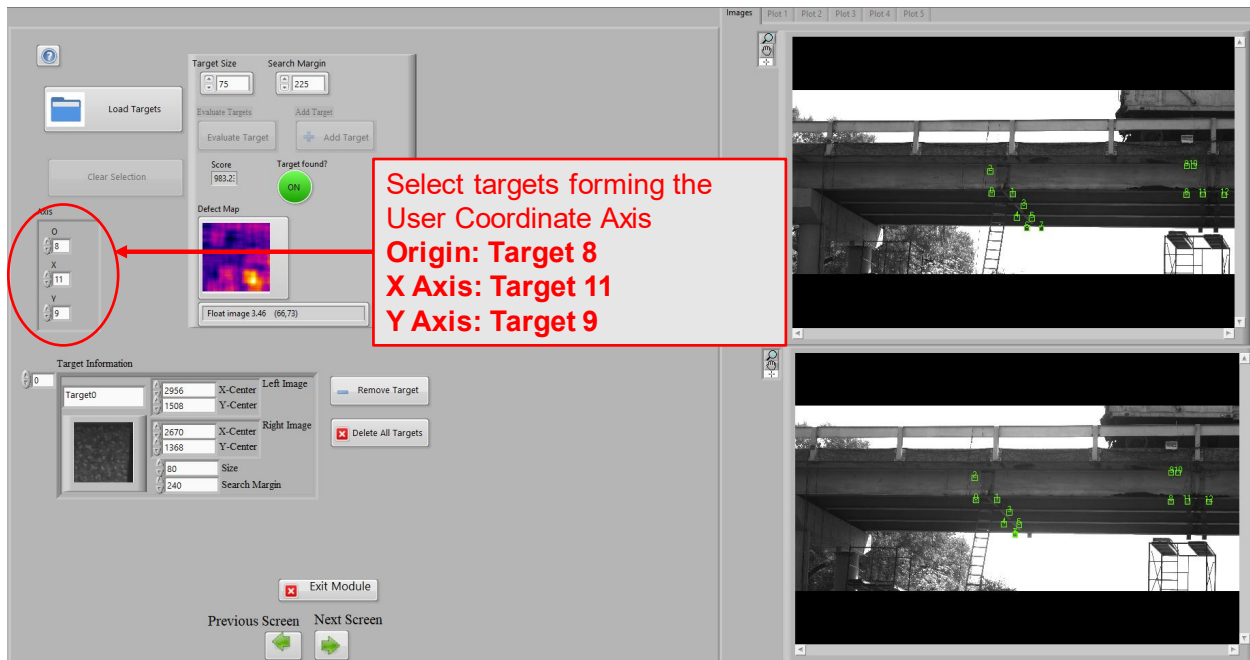

Figure 4-18 selection of targets for Origin, X axis and Y axis of the user coordinate system

The **Load Targets** button in this screen is optional and used to load previously saved targets. This option only works if targets are the same and in approximately the same location in the Right and Left cameras as when the targets were saved.

4.3.7 Reference Images

The next screen is the **Reference Images** screen. In this screen shown in Figure 4-19, the user enters the **Number of Reference Images** to be captured before a test is started. These images serve as the baseline for the zero-deformation state of the structure being monitored. The system will calculate the 3D locations of all targets selected by the user and average those X, Y, and Z coordinates over all the reference frames. These averaged target locations will be used to define the zero deformation and strain state of the structure. The averaging is performed to obtain a robust measure of the true location of the targets and reduce the effects of noise in the readings on the baseline.

The default and recommended number of reference images is 30. The system will capture these images when the user clicks on the **Capture Reference Images** button, at the **Frame Rate** the user specifies. **The selected Frame Rate will be used for the actual test as well.** The captured reference images will be saved in the folder **Reference Images**, and the averaged target coordinates obtained from those images will be stored in the first data line of the coordinate output files (Figure 4-20).

to verify that the system is delivering reasonable values, that targets are in fact being tracked, and that the test is proceeding according to expectations.

As a first step to creating plots, the coordinate system in which target movements will be plotted should be selected. Then the number of desired plots is selected, as shown in Figure 4-21. The maximum number of permissible plot windows is 5.

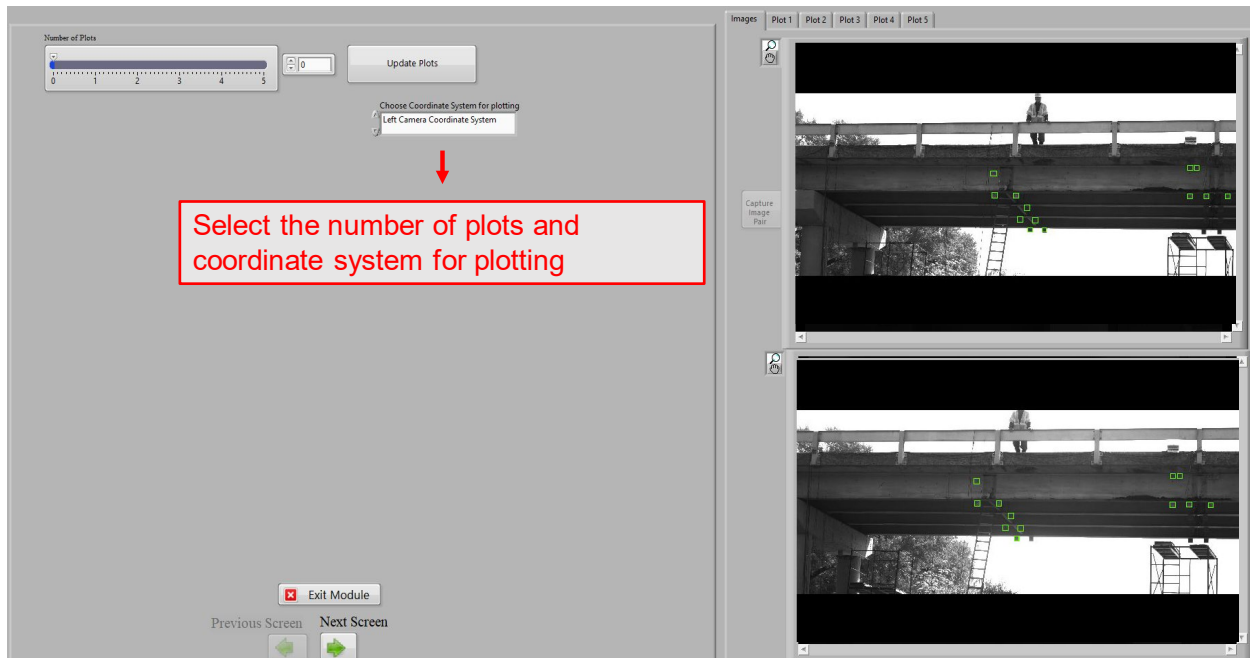

Figure 4-21: **Plotting** screen: selecting the number of plots and coordinate system

For each plot window, an input box is created on the screen as seen in Figure 4-22. In each box, the type of data to be plotted can be selected. The X axis of the plot and Y axis of the plot can represent different data types. The available data types are:

- **Frame Number:** shows the image frame number
- **Time:** displayed in seconds
- **Single Target Directional Movement-X:** displays the movement of each selected target with respect to its original reference position in X direction. The user **MUST** select both target numbers to be the same.
- **Single Target Directional Movement-Y:** displays the movement of each selected target with respect to its original reference position in Y direction. The user **MUST** select both target numbers to be the same.
- **Single Target Directional Movement-Z:** displays the movement of each selected target with respect to its original reference position in Z direction. The user **MUST** select both target numbers to be the same.

- **Single Target Directional Movement-XYZ:** displays the absolute vector movement of each selected target with respect to its original reference position in XYZ direction = $\sqrt{(x - x_0)^2 + (y - y_0)^2 + (z - z_0)^2}$. x_0, y_0, z_0 denote the original reference position coordinates of the target in the x, y, z directions. The user MUST select both target numbers to be the same.
- **Relative Target Movement- XYZ:** calculates the vector movement of the selected targets with respect to each other in the XYZ direction, at each frame. This measure indicates compression between the targets by a negative number and expansion between the two selected targets by a positive number.
- **Strain-XYZ.** Calculates the strain between the two selected targets in the vector XYZ direction. The strain is calculated as the Relative Target Movement between the two selected targets divided by the original distance between them.

Several lines (or data streams) can be plotted on each plot by incrementing the **Line Increment**. The user has the option to select the line color for each data stream. For example, in Figure 4-22, five plot windows are selected. For the first window, Single Target Directional Movement-X versus frame number will be plotted for target 0. In the second window, the Single Target Directional Movement-Y of target 1 versus time will be plotted. In the third window, the Relative Target Movement-XYZ between targets 1 and 2 versus frame number will be plotted. In the fourth window, strain between targets 1 and 2 versus time will be displayed.

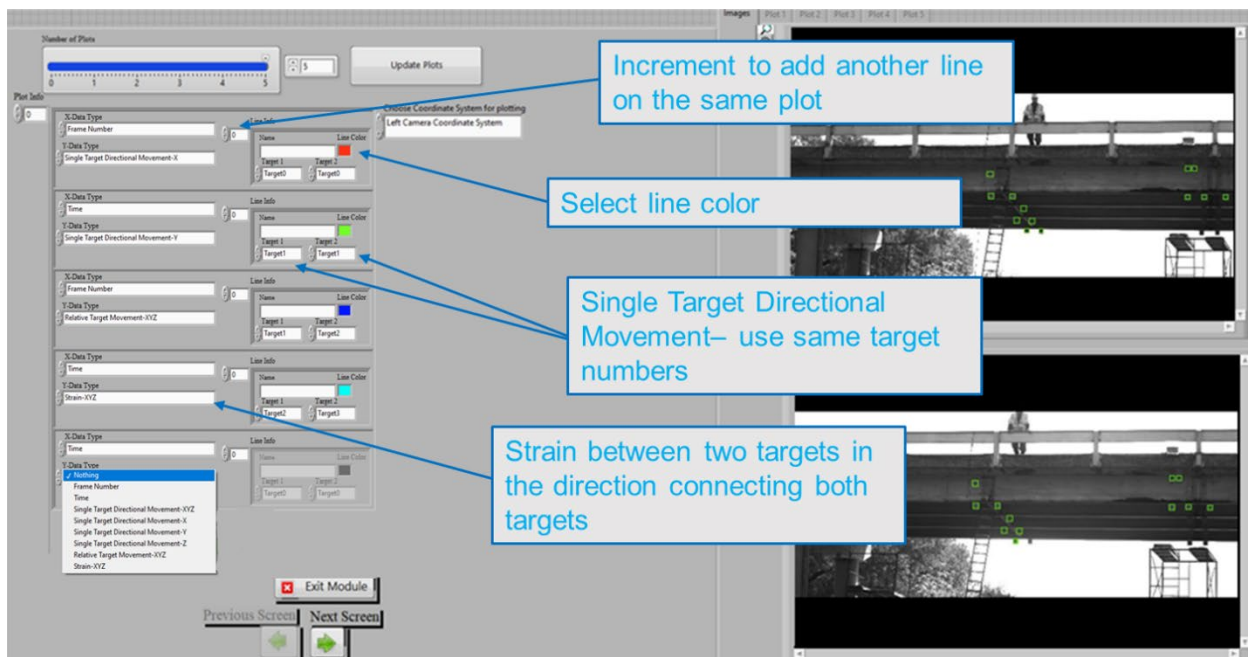

Figure 4-22 Selection of data type and target numbers for plotting

4.3.9 Run Test

The final screen in the **Run Test** screen. *When the user navigates to this screen, they cannot go back to previous tabs.* Before the test is started the cameras are off as shown in Figure 4-23. This feature is provided since a long wait period may be needed between when the CIV system is setup and a test can be started. When ready to begin the test, click the **Start/End test** button. *Cameras will be turned on but recording of images and data will NOT START.* Click the **Run/Pause** button to start image and data recording.

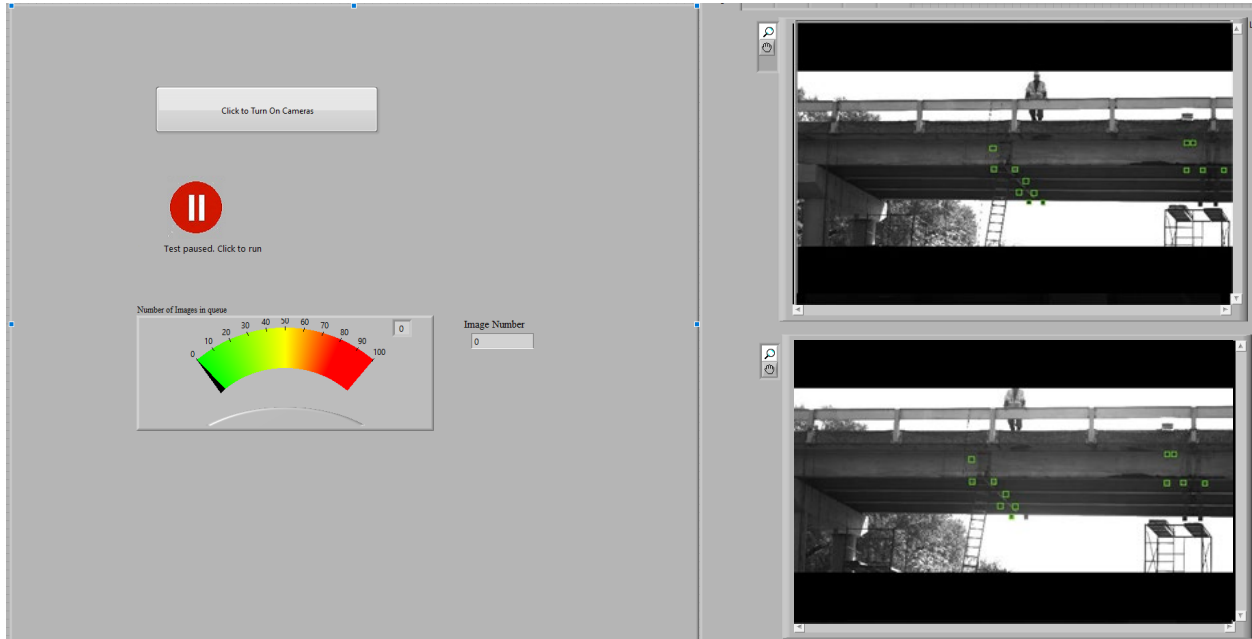

Figure 4-23 **Run Test** screen before a test is started

When a test is running, the **Image Number** index will increase indicating that images and data are being recorded. If plots were created in the previous step, they can be viewed by selecting the appropriate plot tab at the top right of the screen as shown in Figure 4-24.

When saving data is not required during a test but the testing sequence has not been completed, the **Run/Pause** button can be clicked to pause image and data recording. The **Image Number** index will stop increasing when a test is paused.

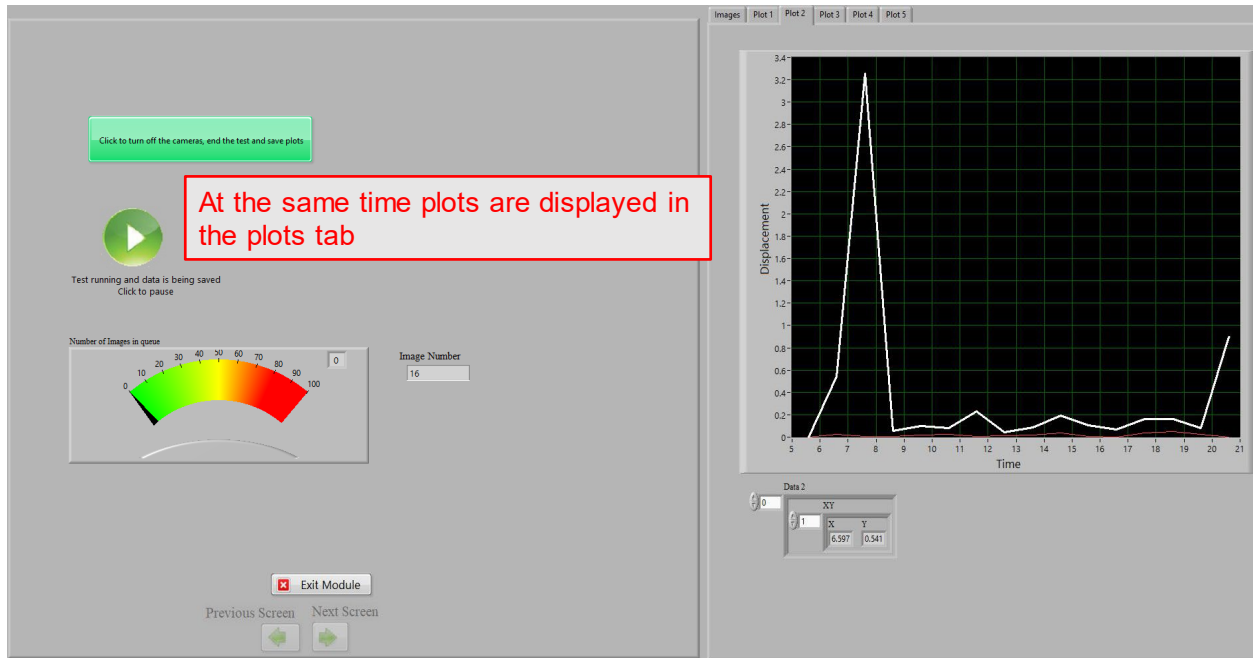

Figure 4-24 **Run Test** screen after a test is started, the run button is pressed, and images and data are being saved. Plot 2 is being displayed here.

If the hard drive cannot write the image files generated as fast as they are acquired, the difference in images is queued or buffered in the computer RAM memory. The number of buffered images is shown on the screen through the **Number of Images in Queue** dial. In Figure 4-25 , a queue of 27 images is shown. Queuing should not occur when images are saved directly to a solid-state drive during acquisition. If the queue keeps increasing, if possible, it is recommended to pause the test to stop acquisition while all buffered images continue to be written on the hard drive. If the problem persists, it is advisable to review the location the project folder and ensure that it is on a solid-state drive or reduce frame rate. These steps would require re-starting a new Live Test.

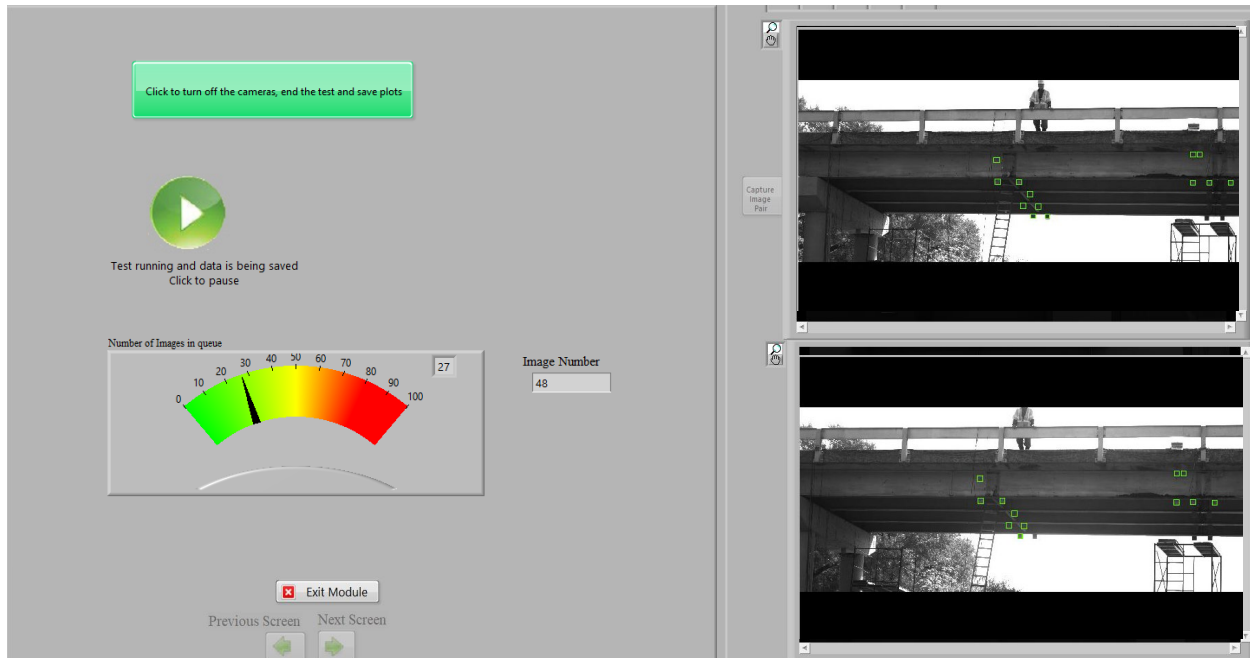

Figure 4-25 Test is started, data is being saved, 27 images are in the queue to be saved

Once a test is completed, click on the **Click to turn off the cameras and save plots** test button located top left of the screen. This will terminate the test and save the plots that have been generated during the test. All queued image will continue to be saved on the hard drive after a test is ended. One can then click on the **Exit Module** button to return to the **Main Menu** screen or terminate the program by clicking on the “X” at the top right corner of the screen.

Images from Left and Right cameras as well as the XYZ coordinates of targets are saved live during the test. This prevents data loss in the event the software is shutdown prematurely or hardware is disconnected accidentally during a test.

4.3.10 Live Test Output files and folder structure

By the end of the Live Test, all test data generated during the live test will have been populated in the project folder structure, as shown in Figure 4-26. In the root project folder, the **Project info.dat** file contains the project information saved in section 4.3.3. The **UserCoordXYZ.csv** and **XYZ.csv** output files contain the 3D spatial coordinates for all the targets selected during the Live Test, in User and Left camera coordinate systems, respectively. A sample content from a target-coordinate output file is shown in Figure 4-27. The first lines of the populated .csv files show all relevant information for the Project and the loaded calibration.

The **Camera setting** folder created in section 4.3.4 contains a file with the user selected camera settings. The **Calibration Results** folder is a copy of the calibration folder that was loaded for the test in section 4.3.5. The **Targets** folder contains all the target sub-images in individual image files. The **Axis Targets** folder contains the information of the three targets that were selected as

the basis for the user coordinate system in section 4.3.6. The *Reference Images* folder contains the reference images saved in section 4.3.7. Lastly, the *Test Images* folder contains all the Left and Right camera images saved during a test. The images are in the uncompressed image format (.bmp).

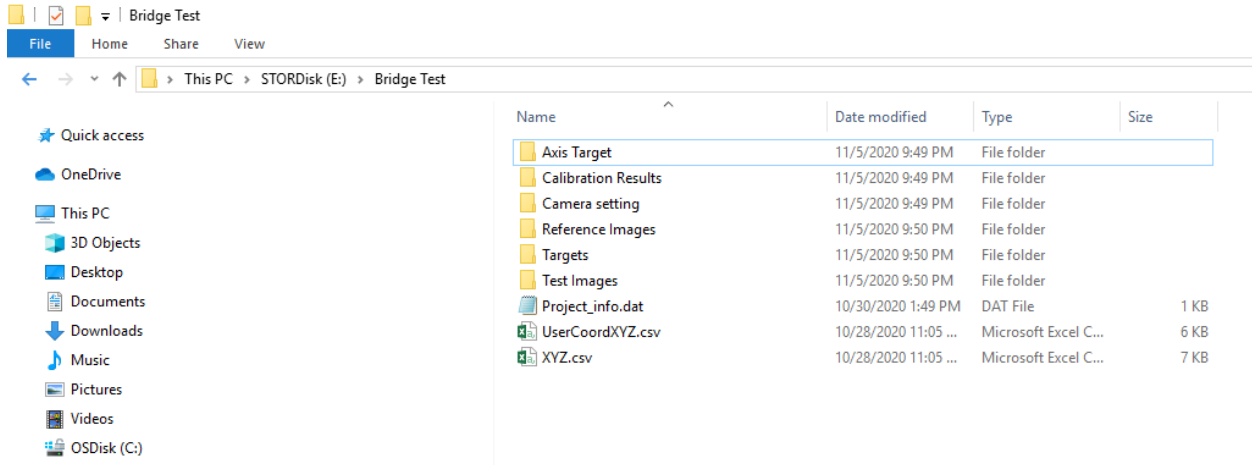

Figure 4-26 Files and folders saved in the project folder during a Live Test

	A	B	C	D	E	F	G	H	I	J	K
1	Project Name	Bridge	Project Date	10/15/2020							
2	Project Info										
3	Gps		-99.34	-39.98							
4	Aperture	f11									
5	Lens Focus Distance	15m-infinity									
6	Exposure time		15000								
7	Frame Rate		2								
8											
9	Coordinate system target numbers										
10	Origin Target		0								
11	X axis Target		1								
12	Y axis Target		2								
13											
14											
15											
16	Calibration Info										
17	4th										
18	Calibration Distance:										
19											
20	Calibration Aperture:										
21											
22	Calibration Focus Distance:										
23											
24	Exposure time:										
25		15000									
26	# Frame	Time	X0	Y0	Z0	X1	Y1	Z1	X2	Y2	Z2
27	Ref Avg		2.113612	22.732077	100.7412	4.672159	22.65964	100.3874	2.455015	20.00764	100.3943
28											
29		1 12/18/2020 PM 14:48:06.928	2.1136	22.7316	100.7388	4.67204	22.65825	100.3807	2.45508	20.00751	100.3921
30		2 12/18/2020 PM 14:48:07.929	2.11355	22.73273	100.7441	4.67204	22.65907	100.3847	2.45488	20.00718	100.394
31		3 12/18/2020 PM 14:48:08.929	2.11353	22.73098	100.7369	4.67209	22.65947	100.3872	2.45498	20.00585	100.3869
32		4 12/18/2020 PM 14:48:09.928	2.11356	22.73209	100.7406	4.67227	22.65934	100.3856	2.45498	20.00739	100.3924
33		5 12/18/2020 PM 14:48:10.931	2.11357	22.73215	100.7411	4.6721	22.6596	100.3873	2.45501	20.00755	100.3931
34		6 12/18/2020 PM 14:48:11.930	2.11367	22.73177	100.7396	4.67201	22.65856	100.3823	2.45494	20.00675	100.389
35		7 12/18/2020 PM 14:48:12.929	2.11357	22.73198	100.7398	4.67205	22.65889	100.3846	2.45506	20.00716	100.3905
36		8 12/18/2020 PM 14:48:13.929	2.11374	22.73236	100.7424	4.67208	22.65952	100.386	2.45516	20.00742	100.3924
37		9 12/18/2020 PM 14:48:14.929	2.11351	22.73162	100.7384	4.67197	22.65835	100.381	2.45495	20.00664	100.3885
38		10 12/18/2020 PM 14:48:15.928	2.1137	22.73221	100.7411	4.67237	22.66018	100.3877	2.45516	20.00798	100.3957

Figure 4-27 Sample target-coordinate output file content

5 POST-PROCESSING OF TEST DATA

The Post-Processing module allows the re-processing of images previously acquired during a test, as well as the post-processing of target coordinate data. Images may be re-processed to: select additional or different targets on the monitored structure, or change the user coordinate system selected in the Live Test. Target coordinate data may be post-processed to: fill in data gaps where targets are lost intermittently (interpolation function), smooth the test data to get smoother visualization of the data, calculate deformation and strain quantities from target spatial coordinates, or plot certain quantities similarly to what can be done during a live test.

Post-processing functionalities are provided in five modules as shown in Figure 5-1. In this chapter, step-by-step instructions are provided for using these modules.

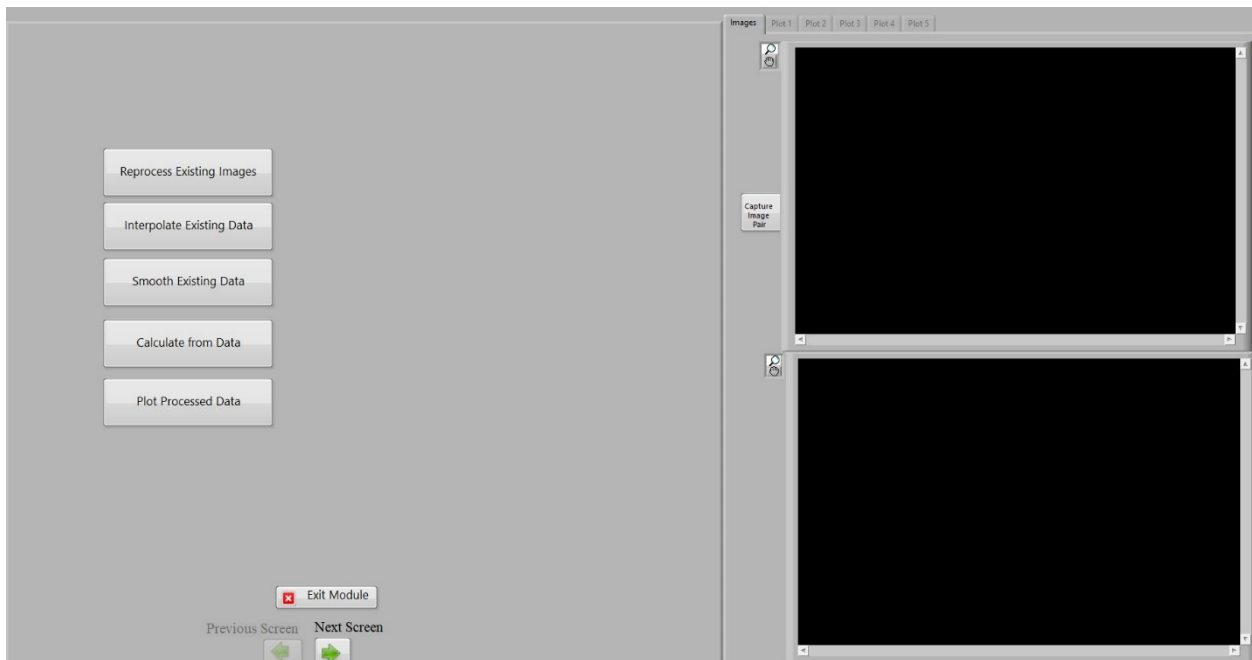

Figure 5-1 **Post-Processing** screen showing the modules

5.1 Reprocessing Existing Images

The steps of this module are very similar to those of the Live Test, except that the images are already acquired. When this module is selected, the CIV software leads the user to the next screen, which is the **Project Selection** screen.

5.1.1 Project Selection

In this screen, shown in Figure 5-2, the project folder containing all the Live Test data and images is selected. The first step is to click on the **Load Project Folder** button. This folder at minimum **MUST** contain the **Reference Images** and **Test Images** in their respective folders.

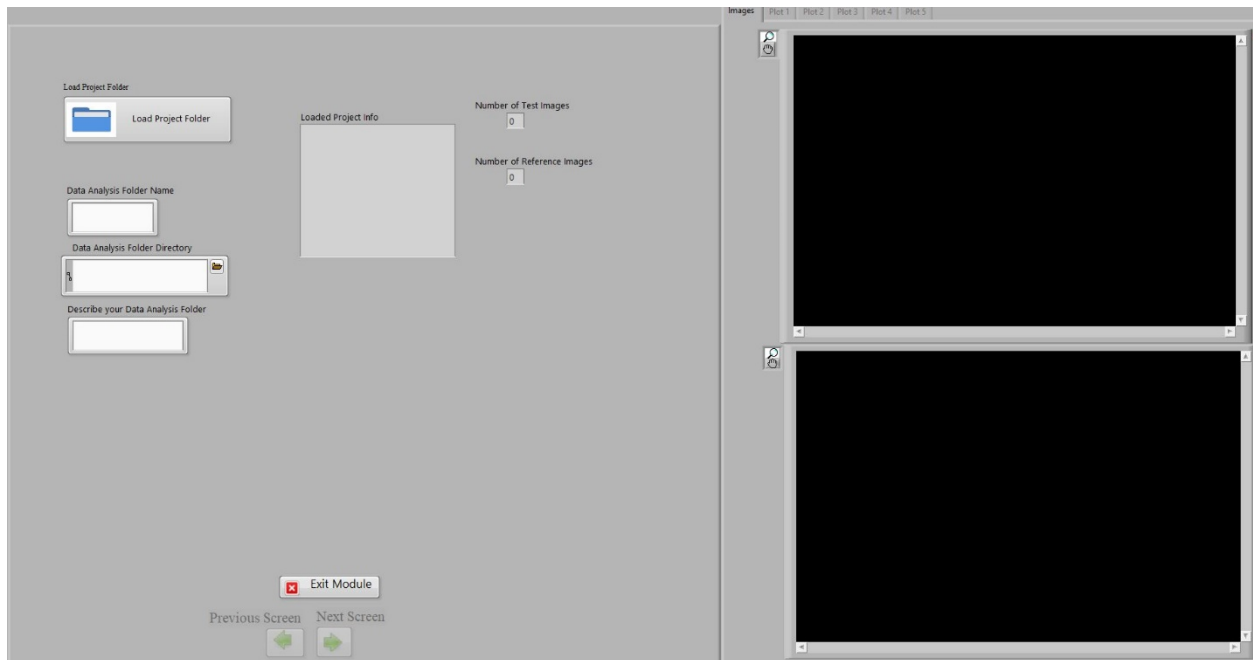

Figure 5-2 **Project Selection** screen: Project folder selection

Name	Date modified	Type	Size
Reference Images	8/10/2020 5:38 PM	File folder	
Test Images	8/10/2020 4:59 PM	File folder	
Project_info.dat	8/3/2020 11:07 AM	DAT File	1 KB

Figure 5-3 Minimum folders required for Reprocess Existing Module

If for any reason the **Reference Images** folder does not exist, the user must create a folder within the project folder, specifically named **Reference Images**, with **Left** and **Right** sub-folders. In those folders, images from the test should be placed that are representative of the zero-deformation state of the structure. If insufficient reference images were saved during a Live Test, additional images taken from the first images acquired during the Live Test can be added to the reference images. For the software to properly identify the reference images, it is important that the folder names exactly match those mentioned above.

When the Project folder is loaded, the project information, number of Reference Images, and number of Test Images are displayed. For example, in Figure 5-4, the loaded project folder contains 250 Test Images and 30 Reference Images.

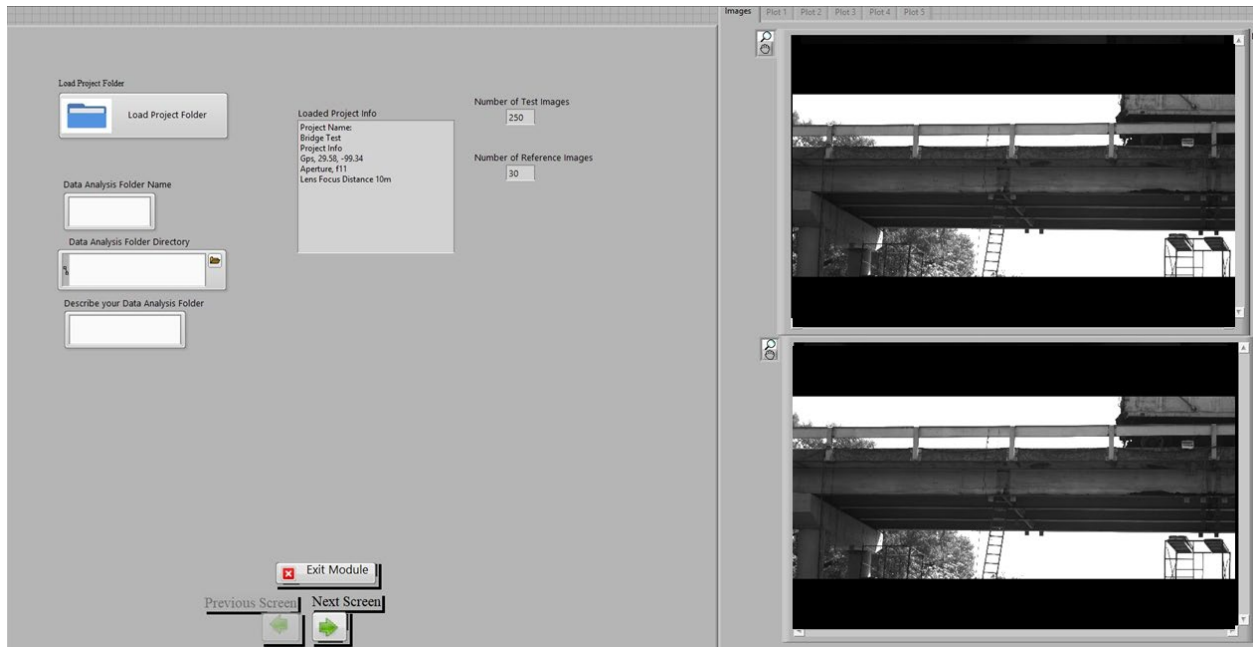

Figure 5-4 **Project Selection** screen: illustration of information displayed after a Project folder is loaded

The next step on this screen is to provide a name for the post-processing data analysis folder, and select a directory where the **Data Analysis Folder** is placed. It is advised to select the Project folder as the parent folder for the analysis folder. Many analyses and analyses folders can be created for any test.

5.1.2 Load Calibration

The next screen is the **Load Calibration** screen. Similarly to the Live Test, the CIV calibration results must be loaded for the software to calculate the spatial coordinates of selected targets. The process here is the same as presented in section 4.3.5.

5.1.3 Target Selection

The next screen is the **Target Selection** screen. Target selection is conducted in the same manner here as done in the Live Test as described in section 4.3.6.

5.1.4 Plotting

User can plot different calculations on the data in a similar manner as the plotting in Live Test as described in section 4.3.8, user can plot different calculations on the data. The plotting displayed in the windows will automatically be saved at the end of the test (section 5.1.5) in a sub-folder of the post-processing folder that was selected in section 5.1.1 called **Post-processing plots**.

5.1.5 Simulate Test

The final screen in the “Reprocess Existing Images” module is the **Simulate Test** Screen. The user needs to select the **Image Range** for the images to be reprocessed and then click on **Process Images**. For example, in Figure 5-5, the image range of 503 to 602 is selected for processing.

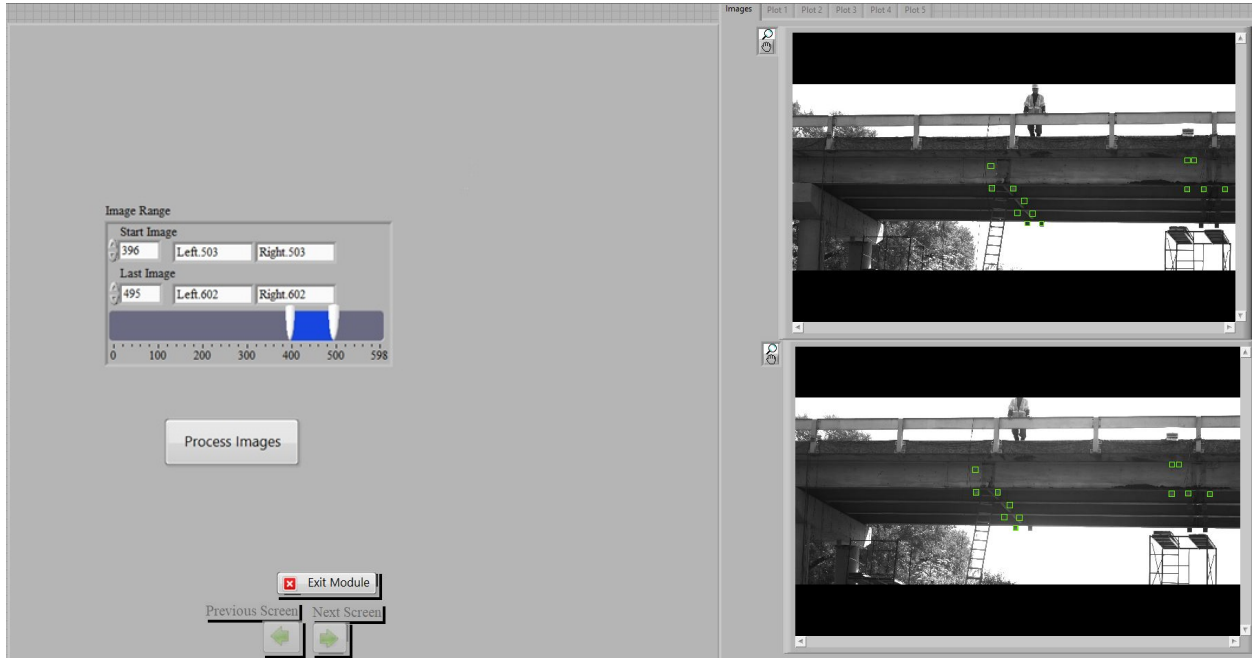

Figure 5-5 Selecting Image Range in Simulate Test Screen

After the images are processed, two .csv files named XYZ.csv and UserCoordXYZ.csv populate in the **Data Analysis Folder**. These files are formatted in the same way as those obtained from a Live Test. In addition, the **Calibration Results** folder, the **Targets** folder, and the **Axis Targets** folder are also generated within the data analysis folder, similarly to those generated in the Live Test (4.3.10).

5.2 Interpolating Existing Data

The CIV program might lose targets intermittently during a test. The interpolation function uses linear interpolation to fill in target location data for frames where a target is lost. The function uses the target locations in the frames bounding the frames in which a target is lost. The user can indicate the maximum acceptable number of frames over which interpolation will be performed. If a target is lost for more sequential frames than that limit, then the interpolation will not fill in the missing data and the output files will maintain the NaN (not a number) values where the targets are lost.

In this screen, shown in Figure 5-6, first the .csv file output file is selected, then the **Open**, button must be clicked to load it. Then the **Interpolation Frame Limit** is input, and finally the **interpolate** button should be clicked.

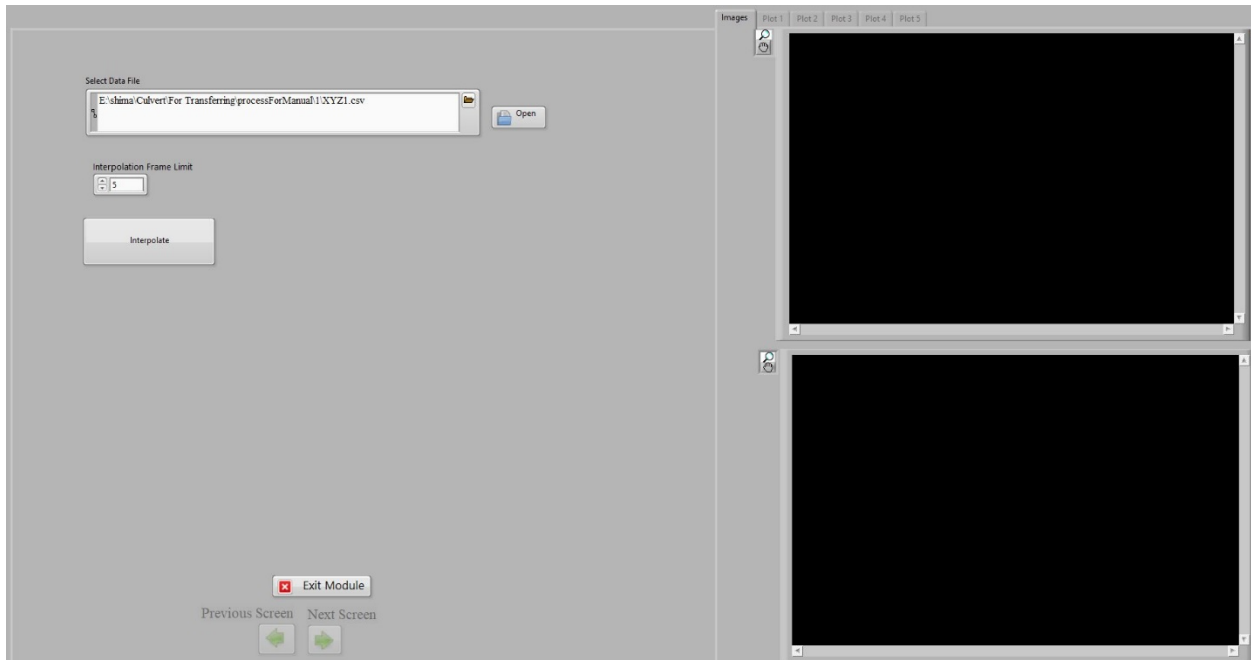

Figure 5-6 Interpolation of the Existing Data Screen

After the interpolating is performed, another .csv file is populated in the same directory as original file that was loaded. The new file is automatically given the same name as the selected file with the extra suffix “interpolated” added to the file name. It is possible to interpolate a data file that was previously interpolated. In this case another “interpolated” suffix will appear at the end of the file name.

5.3 Smoothing of Existing Data

The program offers two different data smoothing methods in the “Smooth Existing Data” module: moving average and moving median. Both options require user input of the window size over which the moving average or median are evaluated for each frame (Figure 5-7).

The data .csv file to be smoothed is first selected on this screen, then the **Open** button is clicked. The **Filtering Type** and **Number of Samples to Average** representing the moving window size are then selected and the **Smooth Data** button is clicked. A similar .csv file is generated with a similar format to the original file but with extra suffix at the end of the original file name; for example, XYZSmoothed.csv.

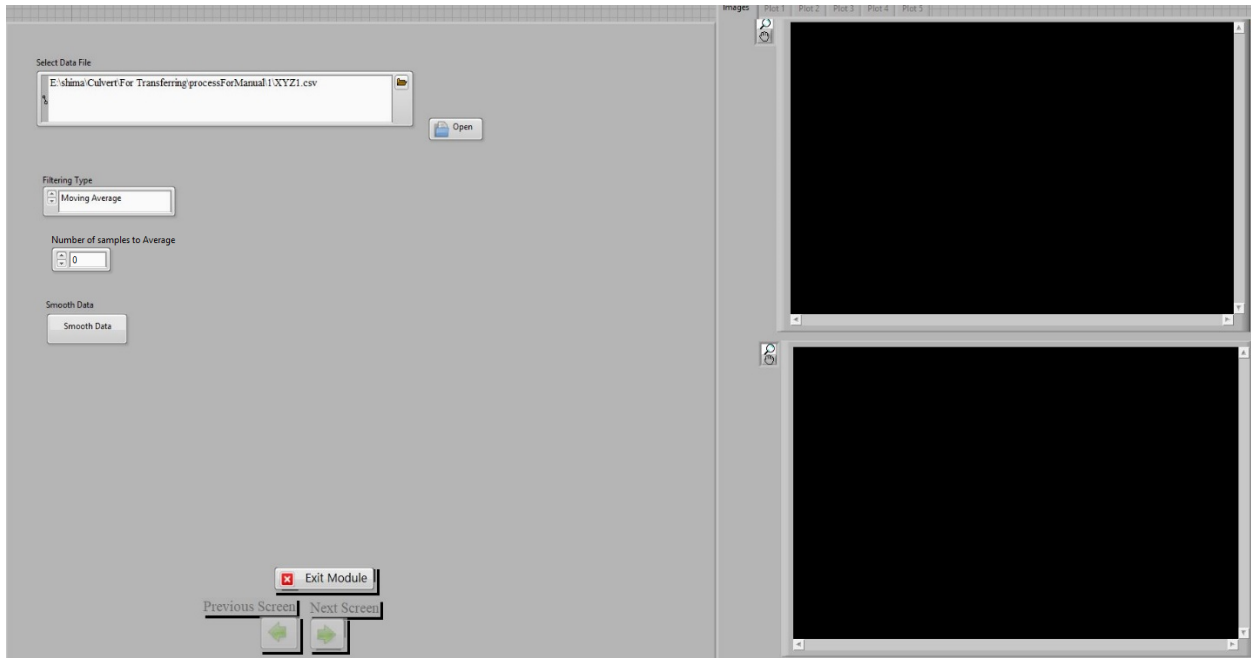

Figure 5-7 Smoothing data screen

A comparison between an original output file used for smoothing and the resulting smoothed output file is presented in Figure 5-8. As can be seen in the figure, the name of the source file used, the smoothing type and windows size are recorded in the new smoothed-data file.

Project Name	Run-1	
Data Analysis Folder Name	1	
Analysis Date	10/7/2020	
Project Info		
Gps	29.1839	-99.1979
Aperture	8	
Lens Focus Distance	Infinity	10-infinity
Exposure time	15000	
Frame Rate	3	
Coordinate system target numbers		
Origin Target	0	
X axis Target	1	
Y axis Target	2	
Calibration Info		
Calibration Name	Calibration50mmLensesForCulvertTest	Calibration Date 10/7/2020
Calibration Unit	Inch	
Calibration Distance Range	35feet	45feet
Calibration Aperture	8	
Lenses Focus Distance(m)	Left Came infinity	Right Cam 10-infinity
Calibration exposure time(microsecond)	15000	

Frame #	Time	X0	Y0	Z0	X1	Y1	Z1	X2	Y2	Z2	X3	Y3	Z3	X4	Y4	Z4
Ref Avg		31.624117	21.561528	-145.103	25.82849	21.73363	-146.509	31.66488	15.22094	-144.536	33.28034	-23.921	-173.37	NaN	NaN	NaN
503	08/31/2020 AM 10:43:18.940	31.60333	21.50215	-145.094	25.80678	21.67293	-146.496	31.6453	15.16281	-144.53	33.26122	-23.9902	-173.367	NaN	NaN	NaN
504	08/31/2020 AM 10:43:19.288	31.60459	21.50237	-145.097	25.81102	21.67585	-146.513	31.64526	15.16233	-144.53	33.25906	-23.9911	-173.364	33.37941	-19.6559	-173.879
505	08/31/2020 AM 10:43:19.605	31.59977	21.50013	-145.077	25.80924	21.67484	-146.503	31.64347	15.16167	-144.523	33.2704	-23.9972	-173.411	NaN	NaN	NaN
506	08/31/2020 AM 10:43:19.965	31.60241	21.50164	-145.088	25.80782	21.67306	-146.496	31.64444	15.16295	-144.526	33.2643	-23.993	-173.382	33.38223	-19.6574	-173.885
507	08/31/2020 AM 10:43:20.268	31.60393	21.50247	-145.097	25.81154	21.6752	-146.514	31.64614	15.16218	-144.534	33.26583	-23.9939	-173.387	NaN	NaN	NaN
508	08/31/2020 AM 10:43:20.620	31.60028	21.49999	-145.079	25.8067	21.67223	-146.495	31.64469	15.16128	-144.527	33.25587	-23.9884	-173.348	NaN	NaN	NaN
509	08/31/2020 AM 10:43:20.974	31.60086	21.49941	-145.081	25.80274	21.66944	-146.477	31.64285	15.16071	-144.522	33.25443	-23.9891	-173.341	33.38019	-19.6552	-173.874
510	08/31/2020 AM 10:43:21.304	31.59785	21.49754	-145.072	25.80385	21.66904	-146.475	31.64284	15.16014	-144.519	33.2577	-23.9902	-173.353	NaN	NaN	NaN
511	08/31/2020 AM 10:43:21.608	31.60186	21.50296	-145.091	25.80994	21.67452	-146.509	31.65161	15.16455	-144.555	33.25951	-23.9926	-173.363	NaN	NaN	NaN
512	08/31/2020 AM 10:43:21.935	31.60029	21.49998	-145.084	25.8059	21.67123	-146.491	31.63827	15.15799	-144.508	33.25768	-23.9911	-173.356	33.38465	-19.6561	-173.879
513	08/31/2020 AM 10:43:22.267	31.60169	21.5008	-145.088	25.80244	21.6686	-146.475	31.64408	15.161	-144.528	33.27	-23.9994	-173.408	NaN	NaN	NaN

Project Name	Run-1	
Data Analysis Folder Name	44111	
Analysis Date	10/7/2020	
Project Info		
Gps	29.1839	-99.1979
Aperture	8	
Lens Focus Distance	Infinity	10-infinity
Exposure time	15000	
Frame Rate	3	
Coordinate system target numbers		
Origin Target	0	
X axis Target	1	
Y axis Target	2	
Calibration Info		
Calibration Name	Calibration50mmLensesForCulvertTest	Calibration Date 44111
Calibration Unit	Inch	
Calibration Distance Range	35feet	45feet
Calibration Aperture	8	
Lenses Focus Distance(m)	infinity	infinity
Calibration exposure time(microsecond)	15000	

Source File Used	XYZ1.csv
Smoothed	Moving Average/K7

Frame #	Time	X0	Y0	Z0	X1	Y1	Z1	X2	Y2	Z2	X3	Y3	Z3	X4	Y4	Z4
Ref Avg		31.624117	21.561528	-145.103	25.82849	21.73363	-146.509	31.66488	15.22094	-144.536	33.28034	-23.921	-173.37	NaN	NaN	NaN
503	08/31/2020 AM 10:43:18.940	31.60333	21.50215	-145.094	25.80678	21.67293	-146.496	31.6453	15.16281	-144.53	33.26122	-23.9902	-173.367	NaN	NaN	NaN
504	08/31/2020 AM 10:43:19.288	31.60459	21.50237	-145.097	25.81102	21.67585	-146.513	31.64526	15.16233	-144.53	33.25906	-23.9911	-173.364	33.37941	-19.6559	-173.879
505	08/31/2020 AM 10:43:19.605	31.59977	21.50013	-145.077	25.80924	21.67484	-146.503	31.64347	15.16167	-144.523	33.2704	-23.9972	-173.411	NaN	NaN	NaN
506	08/31/2020 AM 10:43:19.965	31.60241	21.50164	-145.088	25.80782	21.67306	-146.496	31.64444	15.16295	-144.526	33.2643	-23.993	-173.382	33.38223	-19.6574	-173.885
507	08/31/2020 AM 10:43:20.268	31.60393	21.50247	-145.097	25.81154	21.6752	-146.514	31.64614	15.16218	-144.534	33.26583	-23.9939	-173.387	NaN	NaN	NaN
508	08/31/2020 AM 10:43:20.620	31.60028	21.49999	-145.079	25.8067	21.67223	-146.495	31.64469	15.16128	-144.527	33.25587	-23.9884	-173.348	NaN	NaN	NaN
509	08/31/2020 AM 10:43:20.974	31.60086	21.49941	-145.081	25.80274	21.66944	-146.477	31.64285	15.16071	-144.522	33.25443	-23.9891	-173.341	33.38019	-19.6552	-173.874
510	08/31/2020 AM 10:43:21.304	31.59785	21.49754	-145.072	25.80385	21.66904	-146.475	31.64284	15.16014	-144.519	33.2577	-23.9902	-173.353	NaN	NaN	NaN
511	08/31/2020 AM 10:43:21.608	31.60186	21.50296	-145.091	25.80994	21.67452	-146.509	31.65161	15.16455	-144.555	33.25951	-23.9926	-173.363	NaN	NaN	NaN

Figure 5-8 Comparison of original file (top) and interpolated file(bottom)

5.4 Calculating from Data

This module allows calculation of quantities from target 3D spatial coordinates. The measures that can be calculated are: The **Relative Target Distance**, **Relative Target Movement** and **Strains** between two targets. The measures can be calculated in any of the reference axis X, Y, Z directions, as well as the vector direction connecting two targets, the XYZ direction. In the **Calculate from Data** screen (Figure 5-9), the target coordinate file is first selected (.csv output file) and opened by clicking the **Open** button. In the input box, the type of the calculation, the direction of the calculation and the target pair over which the calculation is to be performed are input. Additional calculations can be defined by incrementing the calculation index at the top left of the input box. The list of the targets to select from is obtained from the output .csv file that is uploaded. After all the calculations are defined, the file a name and a directory for the output calculation file are input and the calculations can be started by pressing the **Calculate and Save** button. A new .csv file with the defined name populates in the selected directory.

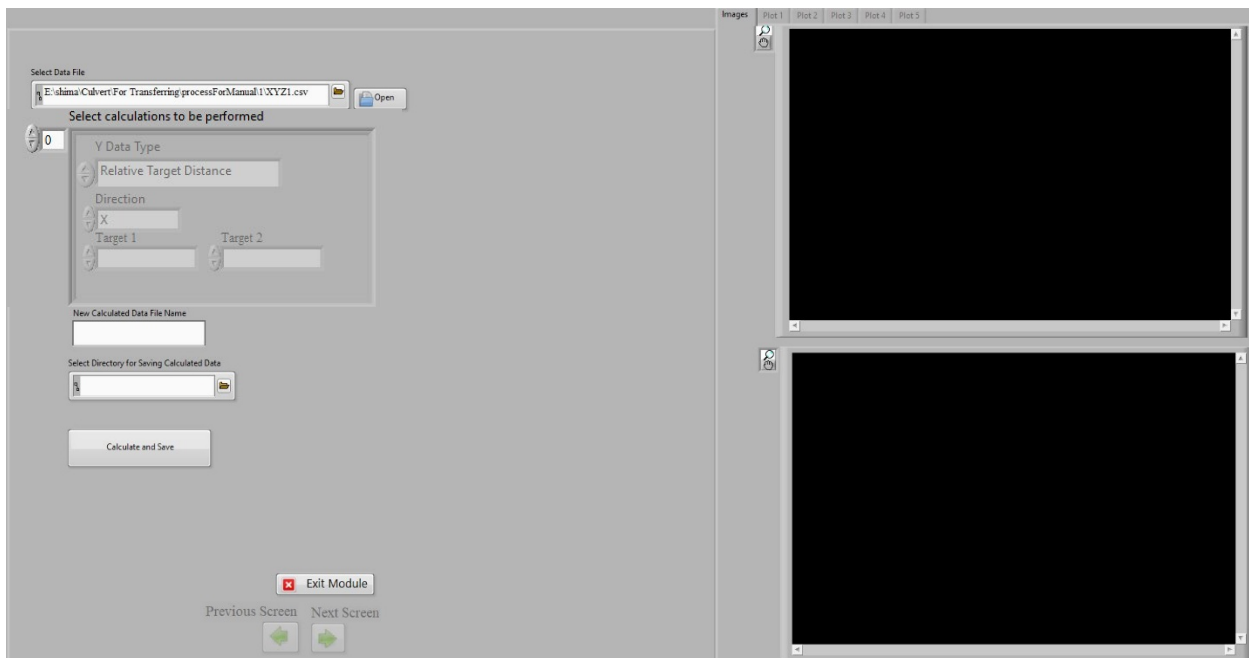

Figure 5-9 **Calculate from Data** Screen

A sample output file generated by the calculation module is shown in Figure 5-10. At the top of the data file, all the project and source data-file information are reproduced. This file does not contain target 3D coordinates, but for each calculation specified, a data column is added with a description of the calculation performed provided as the column title. The file will have as many calculated data columns as the user specifies calculations to be made. All calculations are performed over all the frames of a test. Any data file generated by the software with 3D coordinates of targets can be used in this module. As such, calculations can be made in any

reference coordinate system, for smoothed or un-smoothed data, or for interpolated or un-interpolated data. For strain calculations, the averaged zero-state target coordinates generated from the reference images are used to define the zero-strain state.

Project Name		Run-1					
Data Analysis Folder Name							
Analysis Date		10/7/2020					
Project Info							
Gps		23 1839		-99 1979			
Aperture		8					
Lens Focus Distance		Infinity		10-infinity			
Shutter time		15000					
Frame Rate		3					
Coordinate system target numbers							
Origin Target		0					
X axis Target		1					
Y axis Target		2					
Calibration Info							
Calibration Name		Calibration50mmLens#ofCulvertTest		Calibration Date		10/7/2020	
Calibration Unit		Inch					
Calibration Distance Range		35feet		45feet			
Calibration Aperture		8					
Lenses Focus Distance(m)		Left Cam Infinity		Right Cam 10-infinity			
Calibration exposure time(millisecond)		15000					
Frame #	Time	Absolute Distance between Targets//Target0-Target	Absolute Distance between Targets//Target0-Target	Relative Movement between Targets//Target0-Target7	StrainX//Y/Target0-Target3	StrainY//Target0-Target13	
503	08/3/2020 AM 10:43:18.940	-5.79046	-39.15687	10.558633	-1.546022	-1.546022	
504	08/3/2020 AM 10:43:19.286	-5.78459	-39.15539	10.560703	-1.545897	-1.545897	
505	08/3/2020 AM 10:43:19.605	-5.79239	-39.15503	10.561029	-1.546128	-1.546128	
506	08/3/2020 AM 10:43:19.965	-5.79358	-39.14967	10.559703	-1.546025	-1.546025	
507	08/3/2020 AM 10:43:20.268	-5.79812	-39.14384	10.557003	-1.546089	-1.546089	
508	08/3/2020 AM 10:43:20.620	-5.794	-39.15037	10.558853	-1.545974	-1.545974	
509	08/3/2020 AM 10:43:20.974	-5.79192	-39.15711	10.558933	-1.546019	-1.546019	
510	08/3/2020 AM 10:43:21.304	-5.79439	-39.14308	10.558863	-1.545967	-1.545967	
511	08/3/2020 AM 10:43:21.606	-5.79325	-39.1604	10.559053	-1.546033	-1.546033	
512	08/3/2020 AM 10:43:21.935	-5.79757	-39.14786	10.557963	-1.54598	-1.54598	
513	08/3/2020 AM 10:43:22.287	-5.79858	-39.15702	10.560073	-1.546039	-1.546039	
514	08/3/2020 AM 10:43:22.609	-5.79423	-39.15955	10.558493	-1.546049	-1.546049	
515	08/3/2020 AM 10:43:22.941	-5.79763	-39.15927	10.561383	-1.545981	-1.545981	
516	08/3/2020 AM 10:43:23.275	-5.79742	-39.15669	10.560853	-1.545936	-1.545936	
517	08/3/2020 AM 10:43:23.601	-5.79385	-39.1529	10.558003	-1.545933	-1.545933	
518	08/3/2020 AM 10:43:23.935	-5.79953	-39.1585	10.558653	-1.545948	-1.545948	
519	08/3/2020 AM 10:43:24.269	-5.79436	-39.15048	10.561563	-1.545938	-1.545938	
520	08/3/2020 AM 10:43:24.642	-5.79662	-39.15296	10.560193	-1.545932	-1.545932	
521	08/3/2020 AM 10:43:24.950	-5.79422	-39.15036	10.559763	-1.545962	-1.545962	
522	08/3/2020 AM 10:43:25.291	-5.79335	-39.1531	10.561913	-1.545935	-1.545935	
523	08/3/2020 AM 10:43:25.601	-5.79536	-39.15714	10.559053	-1.546048	-1.546048	
524	08/3/2020 AM 10:43:25.935	-5.79603	-39.15711	10.558643	-1.545925	-1.545925	
525	08/3/2020 AM 10:43:26.268	-5.79465	-39.15002	10.563013	-1.545975	-1.545975	
526	08/3/2020 AM 10:43:26.601	-5.79619	-39.15276	10.558823	-1.545983	-1.545983	
527	08/3/2020 AM 10:43:26.936	-5.79877	-39.15295	10.560793	-1.546047	-1.546047	
528	08/3/2020 AM 10:43:27.268	-5.79394	-39.15388	10.560703	-1.545981	-1.545981	
529	08/3/2020 AM 10:43:27.603	-5.79716	-39.14708	10.560793	-1.545956	-1.545956	
530	08/3/2020 AM 10:43:27.939	-5.78872	-39.1555	10.560763	-1.545975	-1.545975	
531	08/3/2020 AM 10:43:28.289	-5.79609	-39.15026	10.561263	-1.54596	-1.54596	
532	08/3/2020 AM 10:43:28.604	-5.79732	-39.15097	10.559503	-1.545916	-1.545916	
533	08/3/2020 AM 10:43:28.944	-5.79671	-39.15568	10.558403	-1.545767	-1.545767	

Figure 5-10 Calculated file populated from a target coordinate data file

CIV - Civil Infrastructure Vision © - v1.0

Validation Manual

December 2020

TABLE OF CONTENTS

1.	SCOPE.....	1
2.	HARDWARE AND SOFTWARE	2
2.1	HARDWARE.....	2
2.1.1	CIV System Hardware	2
2.1.2	Additional Hardware for Validation.....	2
2.2	SOFTWARE.....	4
3.	CIV SYSTEM SETUP	5
4.	ACCURACY VALIDATION TEST.....	6
4.1	Acquiring Translational Data.....	6
4.2	Post-Processing Test Data using Provided Spreadsheet	16
4.3	Included Spreadsheets for Calculating Errors	17
4.4	Validation Test Output.....	22

LIST OF FIGURES

Figure 2-1: CIV System cameras and computer	2
Figure 2-2: NIST certified gage blocks	3
Figure 2-3: Sample High Contrast Physical Target (HCPT)	3
Figure 2-4: Gage block test device setup for acquiring translation data: (a) Y- direction, (b) Z- direction.....	4
Figure 4-1: Camera Setup screen.....	8
Figure 4-2: Gage block placed at validation distance and in middle center quadrant.....	9
Figure 4-4: Calibration Screen	10
Figure 4-5: Target Selection screen	11
Figure 4-6: Reference axis target (Target 0, 1 and 2) and Center Target (Target 3): (a) Y-direction, (b) Z-direction	11
Figure 4-7: Run Test screen.....	12
Figure 4-8: Pausing the live test to place a gage block below gage test device and noting the frame number	13
Figure 4-9: Placing the gage block (0.75"): (a) Y-direction, (b) Z-direction	14
Figure 4-10: Pausing the live test after a gage block is placed and noting the frame number	15
Figure 4-11: Placing the gage block (2"): (a) Y-direction, (b) Z-direction	16
Figure 4-12: Folder structure showing data and images for quadrant 1 for validation test in Y- direction at 40 feet measurement distance	18
Figure 4-13: Copying the test data from test file to main spreadsheet for validation calculation	19
Figure 4-14: Sample data entry in " Test Details "	20
Figure 4-15: Sample picture of " Calculation Sheet "	21
Figure 4-16: Sample picture of " Test Results " sheet.....	21

LIST OF TABLES

Table 4-1: Validation Test Results at 40ft measurement distance and Y-direction	23
Table 4-2: Validation Test Results at 40ft measurement distance and Z-direction	24
Table 4-3: Validation Test Results at 70ft measurement distance and Y-direction	25
Table 4-4: Validation Test Results at 70ft measurement distance and Z-direction	26
Table 4-5: Validation Test Results at 110ft measurement distance and Y-direction	27
Table 4-6: Validation Test Results at 110ft measurement distance and Z-direction	28

1. SCOPE

As with all measurement devices, the CIV system calibration needs to be verified regularly, and if deemed outside acceptable parameters, re-calibration of the system should be performed.

A procedure for validating the CIV system measurement accuracy is presented in this Validation Manual. Use of this manual requires familiarity with operating the CIV system and refers frequently to the CIV User Manual. This manual does not treat how to re-calibrate the CIV system.

The Accuracy Validation test consists of placing a gage block with known length into a device that translates a High-Contrast Physical Target by the length of the gage block. The CIV system is used to monitor the translational movement of that target and that movement is compared with the gage block length. Measurement error is calculated as the difference between the CIV system measurement and the gage block length. Such a measurement can be performed over the entire measurement volume and in two movement directions: the Y-axis direction is in the plane of the camera sensors, and the Z-axis direction is perpendicular to the plane of the camera sensors.

2. HARDWARE AND SOFTWARE

In this Chapter, the hardware and software required for conducting validation tests for the CIV system are presented. The majority of hardware components used in validation are the same as those used for conducting Live Tests using the CIV system. Additional hardware needed specifically to conduct validation tests are highlighted.

2.1 HARDWARE

2.1.1 CIV System Hardware

CIV system hardware used during a Live Test that are required for the validation of the CIV system calibration include: two cameras set on a tripod, camera power supply cables and Ethernet cables, and a laptop computer with the CIV software (Figure 2-1). For further details on CIV system hardware used for a Live Test, refer to section 3.1 of the User Manual.



Figure 2-1: CIV System cameras and computer

2.1.2 Additional Hardware for Validation

2.1.2.1 Gage Blocks

Gage blocks of known and certified dimensions within the desired measurement accuracy are required to check the measurement accuracy resulting from the current calibration. The gage blocks seen in **Figure 2-2** are NIST certified with a dimensional tolerance on the order of 50×10^{-6} inch. Such blocks are available in different lengths.



Figure 2-2: NIST certified gage blocks

2.1.2.2 High Contrast Physical Targets (HCPT)

A HCPT is a target pattern printed on matte laminate aluminum sheets that are required during the validation of the CIV system. These physical targets are affixed to the testing device so that their movement can be tracked during the Validation Test. HCPT as seen in **Figure 2-3** are supplied along with the CIV system.



Figure 2-3: Sample High Contrast Physical Target (HCPT)

2.1.2.3 Gage-Block Test Device

A gage-block test device is required to perform an accuracy Validation Test as described in Section 4 (See **Figure 2-4**). The gage-block device holds a certified gage block during a Validation Test. The center target in the device moves in the axis of the circular tube when a gage block is introduced between the target and the base of the device.

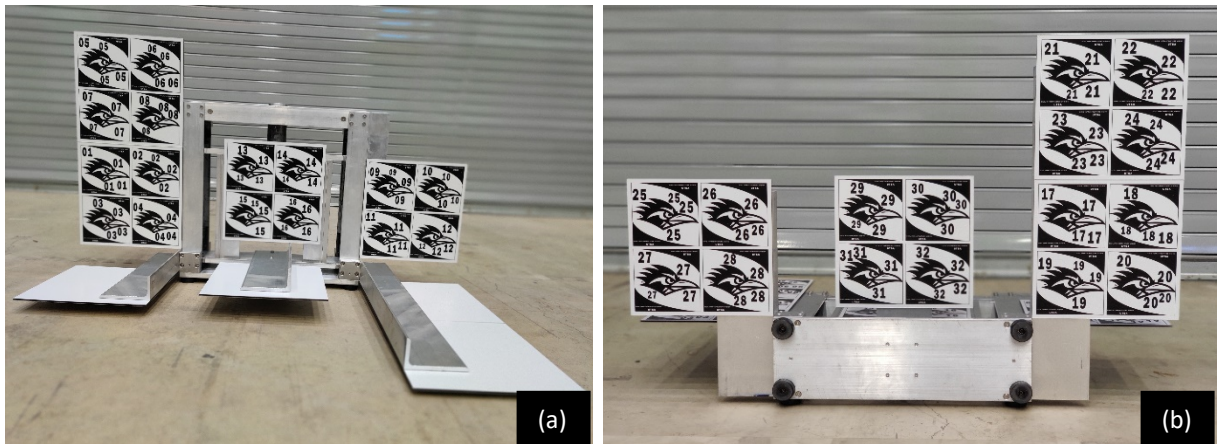

Figure 2-4: Gage block test device setup for acquiring translation data:
(a) Y- direction, (b) Z-direction

2.1.2.4 Distance Measuring Device

A distance measuring device is recommended to measure the distance between the cameras and the gage block test device. This device can be either a measuring tape or a laser distance-measuring device. A distance-measuring device is not supplied with the CIV system.

2.1.2.5 Flood Lights (Optional)

A relatively large F-stop value is used on the camera lenses (See *User Manual section 3.1.6.1*) to maximize the distance range of the measurement volume within which targets are in focus. However, large F-stop values indicate that the lens aperture opening is relatively small. Such a setting is targeted for outdoor bright-light conditions and could make images darker than desired in indoor settings. Additional artificial lighting may be necessary when validation tests are conducted indoors. Such lighting can be provided by flood lights. It is cautioned that halogen lights generate a substantial amount of heat that creates heat ripples in the air above and around them. If such ripples are in the measurement line of sight, they can create additional noise in the data. Halogen lights or other heat generating lights should be placed far from the measurement line of sight. Alternatively, LED lights could be used. Flood lights are an optional hardware that is not supplied with the CIV system.

2.2 SOFTWARE

To conduct validation tests on the CIV system, the Live Test Module and the Post-Processing Module will be used. Please refer to the User Manual for detailed information about the modules.

3. CIV SYSTEM SETUP

Guidance on optimal setup of the CIV system is provided in this section for performing Accuracy Validation of a pre-calibrated CIV system.

It is preferable whenever possible to conduct validation tests indoors. This avoids any lighting variations that can occur outdoors, as well as minimizes any vibrations induced by wind or other external factors. If it is not possible to conduct the tests indoors, care should be exercised to select a day to test when winds are relatively low and lighting conditions are stable (e.g., a sunny day with no clouds). The effects of vibrations and lighting on measurement noise are presented in the User Manual.

Accuracy evaluations should be performed over the entire measurement volume of the CIV system at regular intervals. It is recommended to perform the tests at three discrete distances from the cameras, i.e., at the closest permissible distance of the volume, at mid distance, and at the farthest permissible distance of the volume (Refer to section 4.1.1 of User Manual for details on measurement volume and measurement distance). To conduct the tests at these three distances, either the measurement device can be moved with respect to the cameras, or the cameras can be moved to achieve the desired distance from the device. For the CIV bridge calibration, the range of permissible measurement distances is from 40 feet (12.19 meters) to 110 feet (33.53 meters). Based on this range, three validation distances, i.e., 40 feet (12.19 meters), 70 feet (21.34 meters) and 110 feet (33.53 meters) are selected to validate the CIV system.

Tests should also be performed across the field of view at each distance. It is recommended to divide the field of view into nine quadrants resulting from a gridding of the field of view into three horizontal and three vertical divisions. Accuracy Validation should be performed in each of these quadrants for each measurement distance. For the farther distances, the field of view can be quite large. For example, at 110ft (33.53m), horizontal length of the field of view is 46.75 feet (14.25m) while the vertical length is 30.91 feet (9.42m) (Section 4.1.1 of the User Manual). To cover such a field of view by moving the measurement device can be challenging, particularly in the vertical direction. Alternatively, the cameras can be rotated by adjusting the tripod legs to place the measurement device in the various quadrants of the field of view.

4. ACCURACY VALIDATION TEST

During an Accuracy Validation test, a gage block with known length is inserted into the provided device that translates a High-Contrast Physical Target by the length of the gage block. The CIV system is used to monitor the translational movement of that target and that movement is compared with the gage block length. Measurement error is calculated as the difference between the CIV system measurement and the gage block length. Such a measurement can be performed over the entire measurement volume and in two directions: the Y-axis direction is in the plane of the camera sensors, and the Z-axis direction is perpendicular to the plane of the camera sensors.

Accuracy Validation tests involve two distinct tasks:

- 1- Acquiring translational data using the CIV system for the target offset by the insertion of gage blocks into the gage-block test device.
- 2- Processing the data to obtain a measure of accuracy of the system over the entire measurement volume and for both in-plane (Y-direction) and out-of-plane (Z-direction) translations.

4.1 Acquiring Translational Data

Several separate Live Tests need to be conducted to obtain accuracy data over the full measurement volume and in two directions of translation. A separate Live Test will be conducted for each measurement distance, each quadrant in the field of view, and each direction of translation. If the measurement volume is divided into three discrete measurement distances and nine quadrants in the field of view (See Section 4.2), then the measurement volume is divided up into $3 \times 9 = 27$ validation quadrants. In each validation, the quadrant measurements should be performed in both the Y and Z directions, then the total number of Live Tests to be conducted is $27 \times 2 = 54$ tests.

In addition, it is recommended to use two gage block lengths in each validation quadrant that cover the range of expected target movements in the target application. Using multiple gage blocks in the same validation quadrant and measurement direction does not require separate Live Tests because the Live Test can be paused between the placement of each gage block into the gage-block device. For bridge load test monitoring, bridge deflections can be on the order of a few hundredth of an inch, for localized strain readings, to a few inches for long-span flexible bridge deflections. Gage blocks of 0.75in. and 2.0in. lengths cover that range reasonably well without needing to use very small blocks that are difficult to handle in the gage-block device.

Below is a summary of the steps required to obtain the translation data measured by the CIV system that will be compared with gage-block lengths. These steps should be repeated for each individual Live Test in each validation quadrant and for each measurement direction. The process requires the use of the Live Test module described in the User Manual.

- 1- Setup the cameras in the desired location (preferably indoors)
- 2- Place the gage-block device at the desired distance from the cameras and in the desired orientation (for Y-axis or Z-axis direction measurement)
- 3- Start a new Live Test using the Live Test module in the CIV software
- 4- Input the project/test information
- 5- Select the cameras settings
- 6- Adjust the cameras and/or gage-block device to place the gage-block device in the center of the desired validation quadrant
- 7- Load the calibration to be validated
- 8- Select the center target that translates with the insertion of a gage block and the three targets on the outside of the gage block device that create a reference axis for the measured translation
- 9- Acquire about 30 images before the first gage block is placed in the device then pause acquisition (note the image number at pausing)
- 10- Add a gage block in the device
- 11- Acquire another 30 images (approximately) and then pause acquisition (note the image number at pausing)
- 12- Repeat steps 10 and 11 for all desired gage block lengths
- 13- Exit the Live Test Module

For Steps 3 and 4, please follow the steps in the User Manual for running the CIV software, selecting the Live Test module, and getting to the **Camera Setup** screen.

Hint: each test will need a unique project name that will create the folder structure where all the data and images are stored for that test. To facilitate post-processing of the data, it is recommended to use a sequential naming scheme across validation quadrants. For example, if the nine field-of-view quadrants are numbered from 1 to 9, an example project name could be: **ValidationTest_date_40ft_1_Y**. This project name includes the measurement distance, number of field-of-view quadrant, and the measurement direction built into the name.

Step 5: Select camera settings

The **Camera Setup** screen is shown in **Figure 4-1**. Prior to turning on the cameras and starting image acquisition, the region of interest (ROI) must be defined. Since it is desired to validate system accuracy for the entire field of view, do not change the ROI settings.

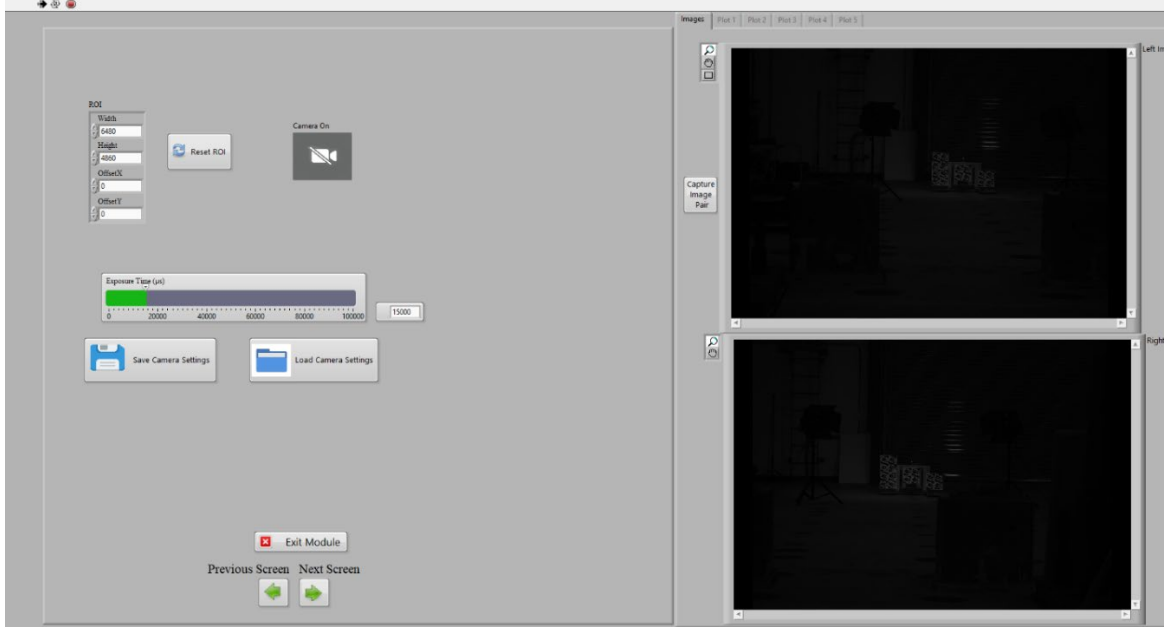

Figure 4-1: **Camera Setup** screen

- Turn on the cameras to see their viewpoints, click on the Camera On/Off button

The left and right camera images are now shown on this screen as acquired live by the cameras. This is a good time to set the image exposure time (as described in the User Manual). Exposure time cannot be set while the cameras are turned on. This step may require iterating between setting an exposure time and turning on and off the cameras. Please refer to the User Manual for tips on selecting an appropriate exposure time.

Step 6: Placement of gage-block device

Next, while the cameras are on, adjust the positioning of cameras and/or gage-block device to obtain the desired placement of the device. For Accuracy Validation tests, this involves either moving the gage-block measurement device or rotating the cameras on the tripod until the measurement device is in the appropriate quadrant in both camera images (See **Figure 4-2**). Since camera viewpoints differ, placing the measurement device exactly at the center of the validation quadrant of both cameras may not be possible. As mentioned previously, moving the device into the correct quadrant while keeping the cameras fixed may be simple for closer measurement distances that have smaller fields of view. This method may however be difficult for farther distances and larger fields of view, for which rotating the cameras may be easier.

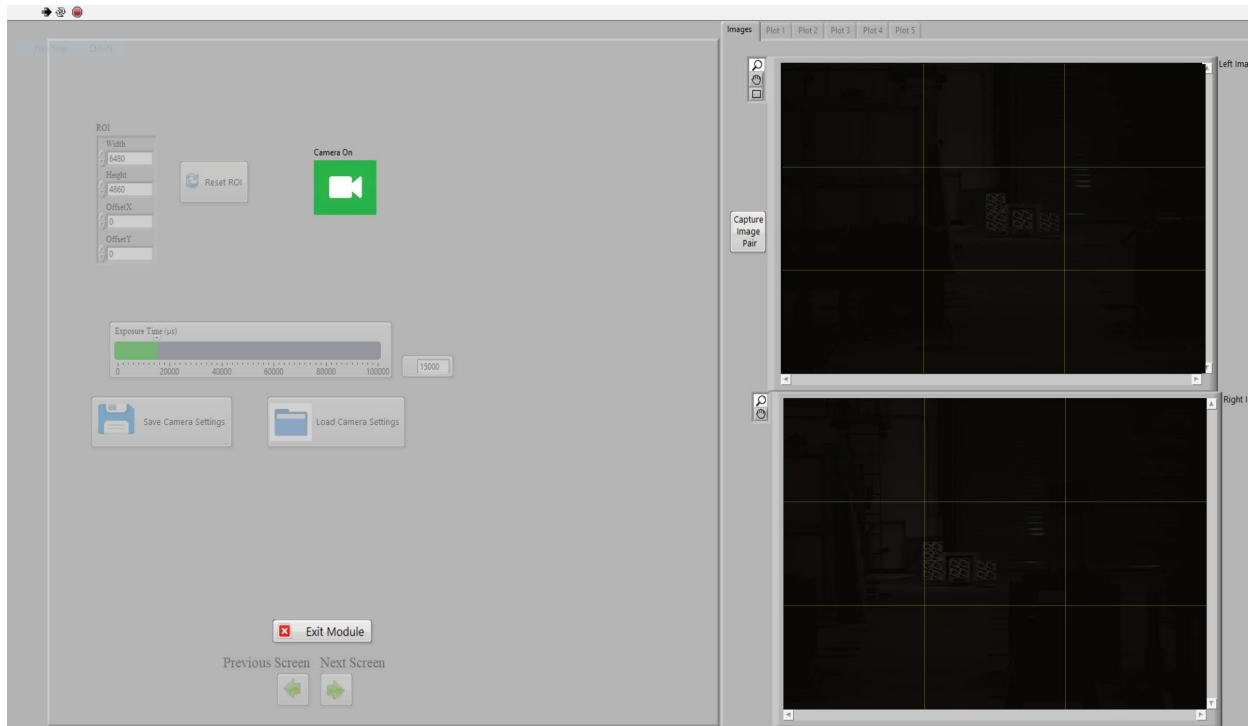

Figure 4-2: Gage block placed at validation distance and in middle center quadrant

You may save the camera setting for loading during a subsequent test. This feature may be useful here since the same cameras setting will be used for all validation tests.

Step 7: Load the calibration to be validated

The following screen is the **Calibration** screen (**Figure 4-4**). In this screen, the user is asked to provide the location of the calibration files to load. The CIV system is pre-calibrated and delivered with an initial calibration folder and files as described in the User Manual. Load the calibration as described in the User Manual.

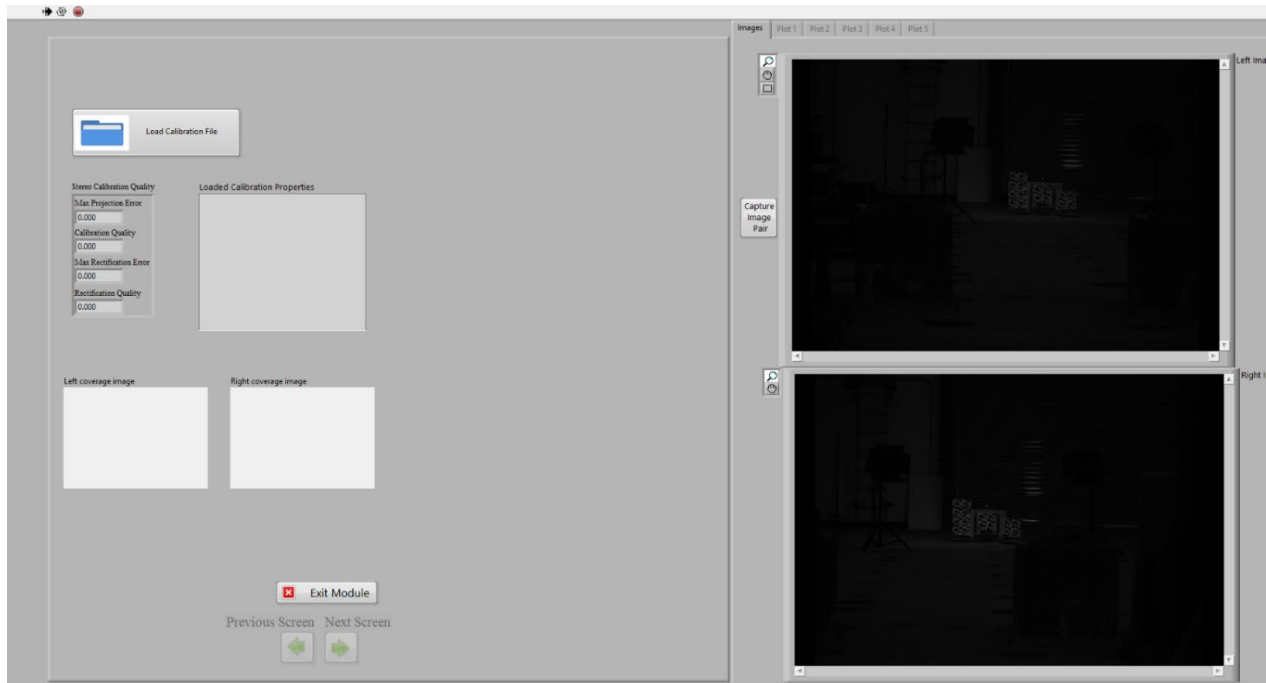

Figure 4-4: **Calibration** Screen

Step 8: Target selection

The following screen is the **Target Selection** screen (**Figure 4-5**). Please follow the steps described in the User Manual for selecting and saving each individual target. It is advised to use target sizes of 100x100 pixels, but never less than 60x60 pixels.

For this application of validating the measurement accuracy of a calibration, four targets need to be selected on the gage-block device. For post-processing of the data using the pre-programmed excel sheet (see section 4.2), it is necessary to select the four targets in the order shown in **Figure 4-6**. Target 3 is the center target that translates with the insertion of the gage blocks. It is best to select a Target such that its center is as close as practically achievable to the central axis of translation (centered along the circular tube attaching the target to the frame, **Figure 4-6**). **Target 0** is the one at the bottom left of the outer edge of the gage-block device. This target will be the origin of the reference axis. **Target 1** should be the outer edge target that define the x-direction for the reference axis, while **Target 2** is the one defining the y-direction of the reference axis. **It is essential to select Target 0 and Target 2 to be as aligned as possible with the axis of movement for Y-direction tests. The movement that will be compared with the gage block length will be the one aligned with these two targets. It is also important to select Target 1 to create as close to a 90-degree angle between the three axis targets as practical.**

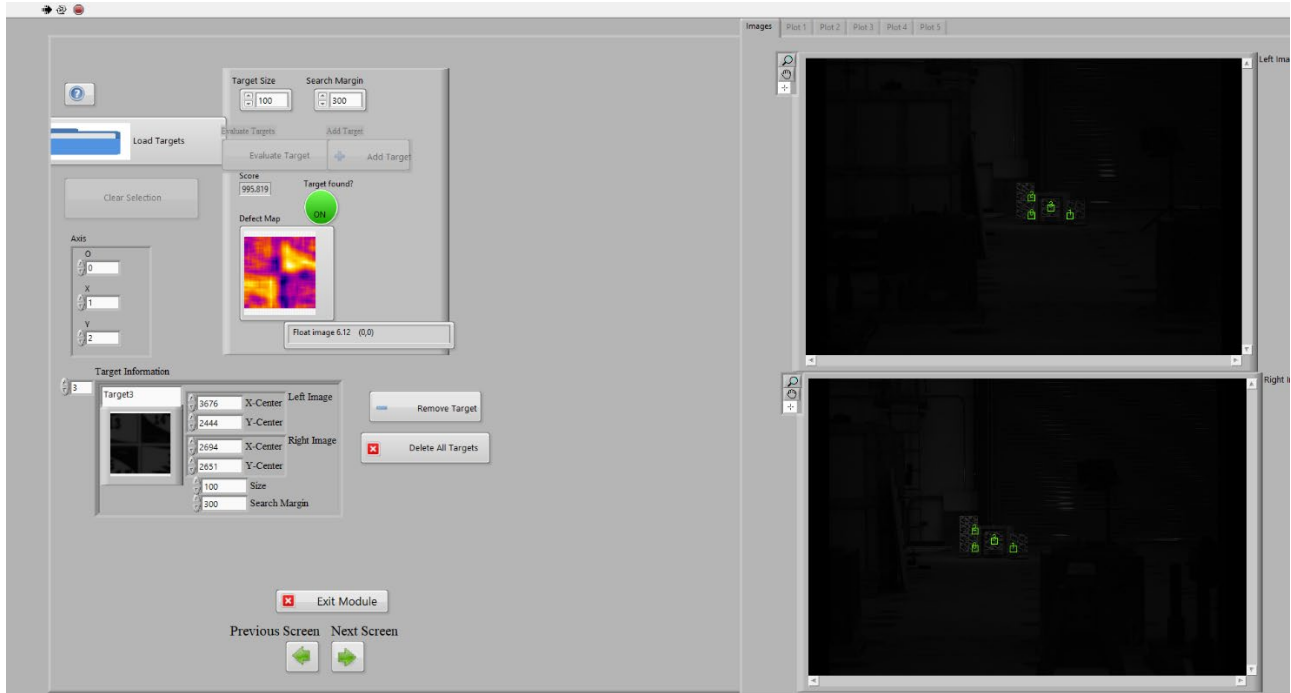

Figure 4-5: Target Selection screen

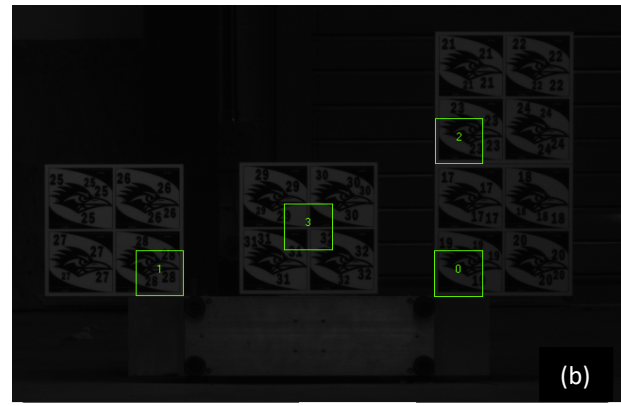

Figure 4-6: Reference axis target (Target 0, 1 and 2) and Center Target (Target 3):
 (a) Y-direction, (b) Z-direction

Once the four targets are selected and saved, provide the correct target numbers in the Axis box to create the reference coordinate system from which all three-dimensional spatial coordinates will be provided by the CIV software. As mentioned above, use Target 0 as the origin, Target 1 as the X-axis target and Target 2 as the Y-axis target.

Step 9: Acquire images before a gage block is inserted

Next, navigate to the **Run Test** screen (**Figure 4-7**).

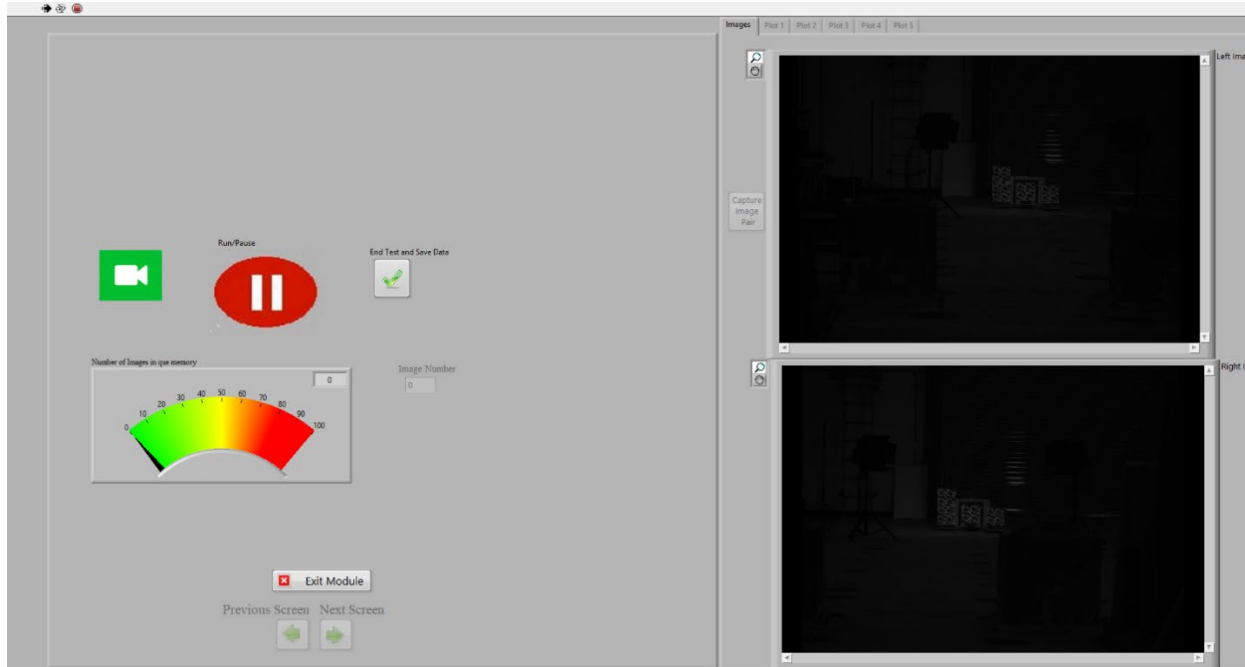

Figure 4-7: Run Test screen

Reference images: It is not necessary to take reference images in this application since these will be taken during the test. Since the CIV system does not allow a value of zero for the number of reference images, however, input at least 1. These images will not be used. In this screen you select the desired frame rate. The rate is immaterial to the Validation Test. A faster rate will help accelerate the process.

Live plotting: If live plotting is desired, setup the live plots as described in the User Manual before reaching the Run Test screen.

Turn the cameras on using the On/Off button.

Before placing any gage block in the device, start acquiring images by pressing the Run button. **Capture around 30 images** and then pause the acquisition using the Pause button (**Figure 4-8**).

Note the image number at pausing. This image number will be input on the sheet named “Test Details” of the provided calculation spreadsheets. This number will be used in the post-processing of the data to indicate the transition frame after which the gage block is inserted in the device.

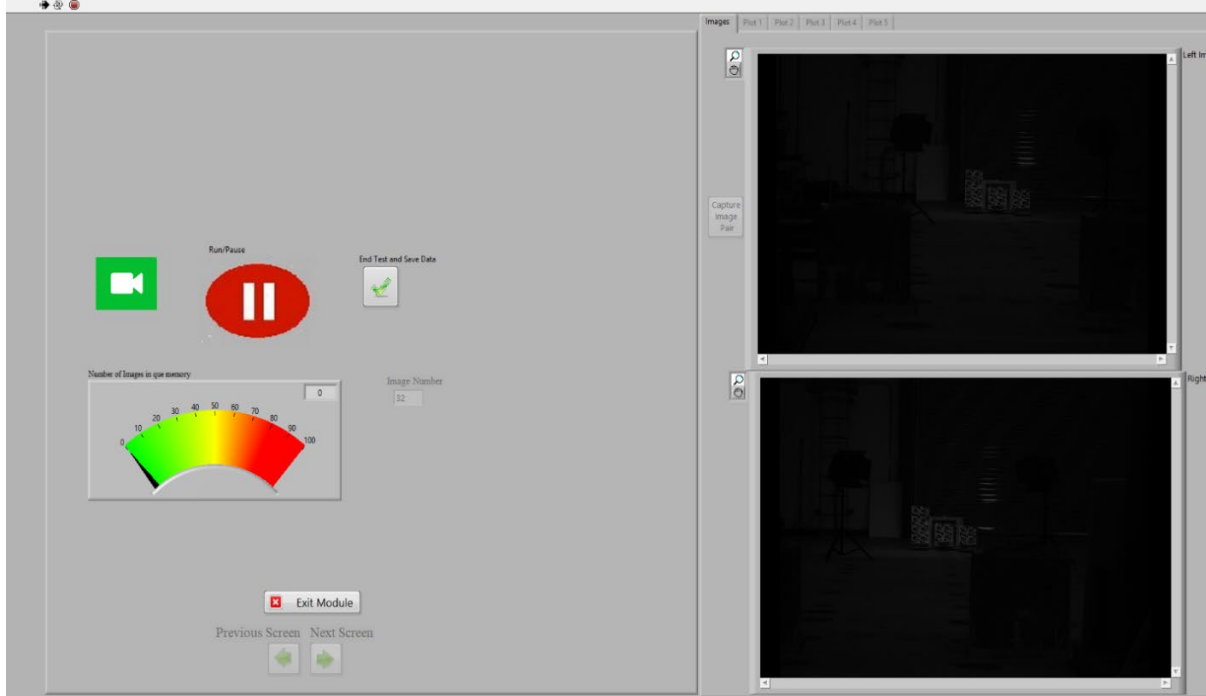

Y-axis-40 ft- Final Sheet - Excel

Distance	Reference Axis Target			Direction	Y
	Origin	X-axis	Y-axis	Center Target	
Target Number	0	1	2	3	
Quadrant Number	Image Quadrant	Gage Block Size (inch)	Frame Start	Frame End	
1	Top Left	0	0	32	
2	Middle Left				
3	Bottom Left				
4	Top Center				
5	Middle Center				
6	Bottom Center				
7	Top Right				
8	Middle Right				
9	Bottom Right				

Figure 4-8: Pausing the live test to place a gage block below gage test device and noting the frame number

Step 10: Insert desired gage block

Insert the desired gage block in the gage-block device by lifting the inner-target sliding frame and sandwiching the gage block between the inner frame and the bottom of the frame (**Figure 4-9**).

Warning: Be careful to insert the gage block with the known dimension aligned with the movement of the center target.

Warning: Care should be exercised not to move the gage-block device during placement of a gage block.

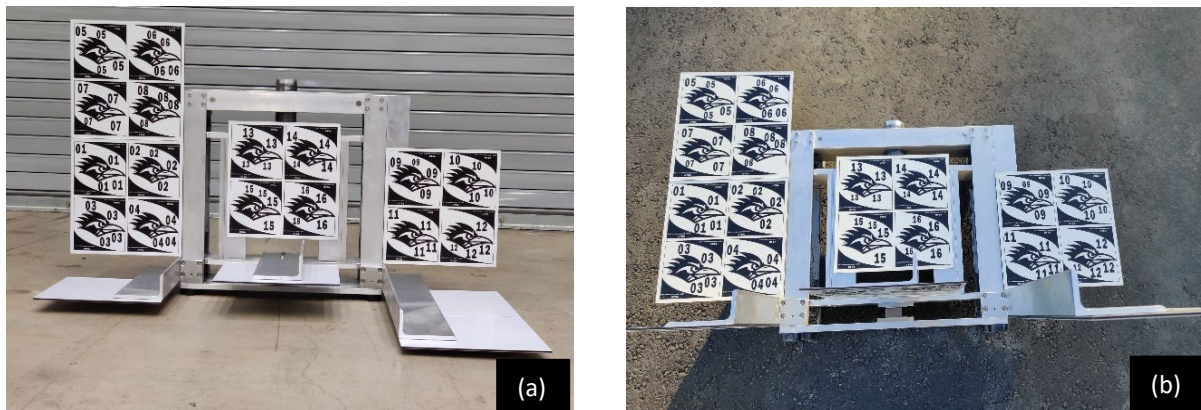
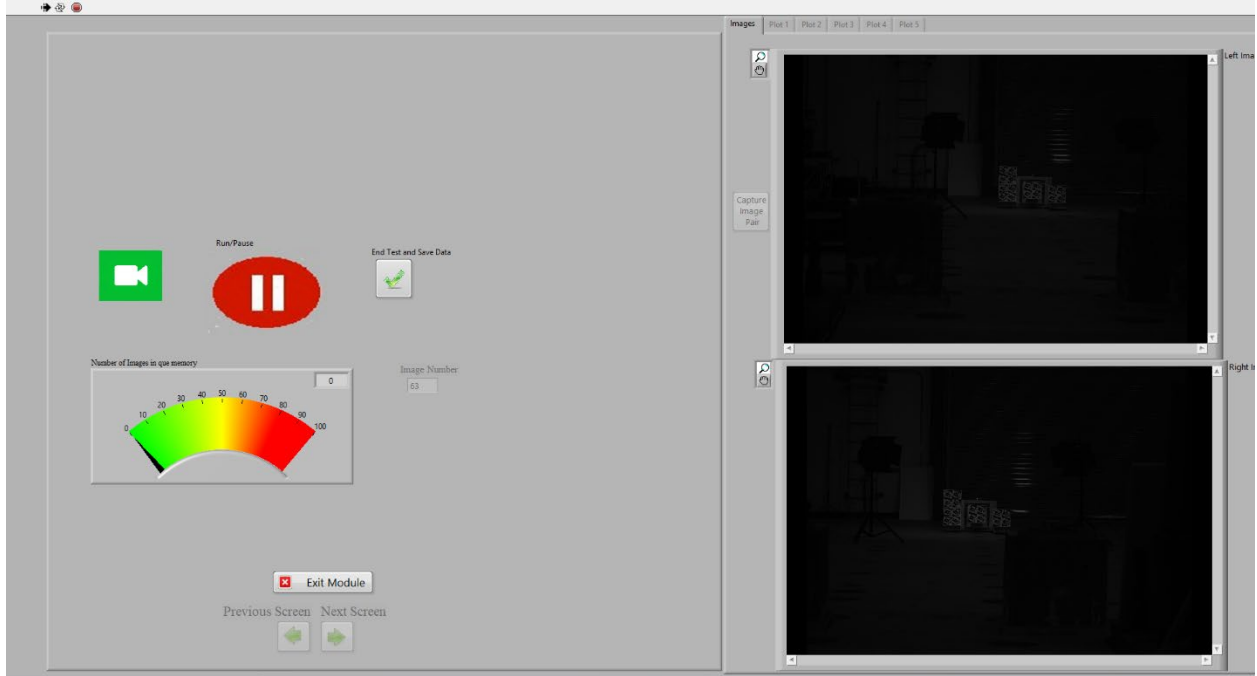

*Figure 4-9: Placing the gage block (0.75''):
(a) Y-direction, (b) Z-direction*

Step 11: Acquire images with a gage block inserted

With the desired gage block in the device, start acquiring images by pressing the Run button. **Capture around 30 images** and then pause the acquisition using the Pause button (**Figure 4-10**).

Note the image number at pausing on sheet “Test Details” of the provided spreadsheet (**Figure 4-10**). This number will be used in the post-processing of the data to indicate the transition frame after which the gage block is inserted in the device.



Excel spreadsheet showing test details. The table below is extracted from the spreadsheet.

Distance	70 feet			Direction	Y
	Reference Axis Target				
Target Number	Origin	X-axis	Y-axis	Center Target	
0	1	2	3		
Quadrant Number	Image Quadrant	Gage Block Size (inch)	Frame Start	Frame End	
1	Top Left	0	0	32	
		0.75	33	63	
2	Middle Left				
3	Bottom Left				
4	Top Center				
5	Middle Center				
6	Bottom Center				
7	Top Right				
8	Middle Right				
9	Bottom Right				

Figure 4-10: Pausing the live test after a gage block is placed and noting the frame number

Step 12: Repeat steps 10 and 11 for all desired gage block lengths

The **Figure 4-11** shows placement of 2" length gage block below the center target.

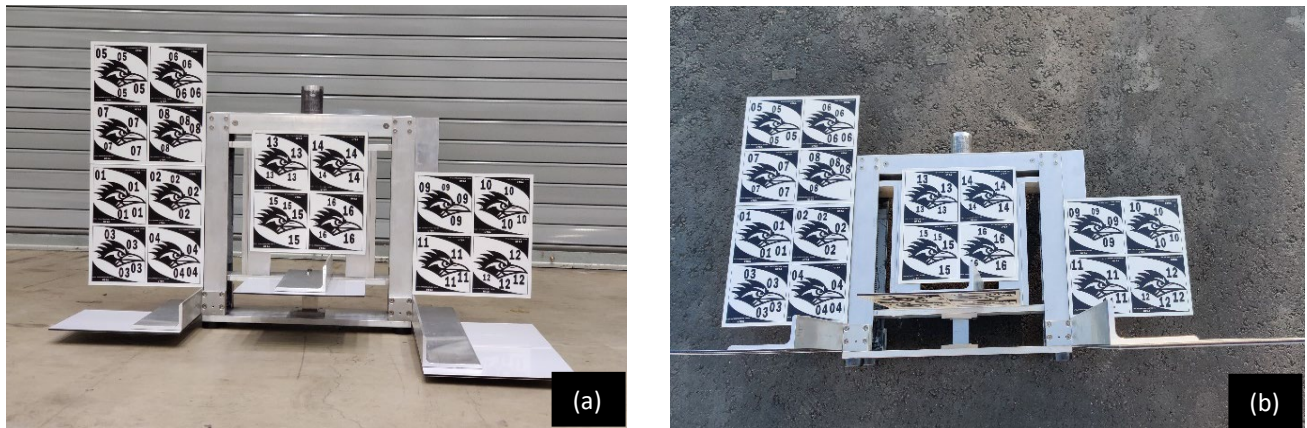

*Figure 4-11: Placing the gage block (2''):
(a) Y-direction, (b) Z-direction*

Step 13: Exit the Live Test module

This completes the process of acquiring translation data for one Live Test. As noted earlier, 54 live tests are needed for the entire measurement volume. The next step is to process the data that is automatically saved by the CIV system.

4.2 Post-Processing Test Data using Provided Spreadsheet

Since the targets needed for the Accuracy Test were selected in each test, the CIV system calculated their locations in three dimensions with respect to the selected user axis. The data is stored in a csv file in each project/test folder as described in the User Manual. It is therefore not necessary to re-process the images to get target locations using the Post-Processing module. Images for each test are however automatically saved by the CIV software. If it is desired to re-select targets for a particular test and re-calculate their three-dimensional locations, re-processing of the images can be performed using the Post-Processing module as described in the User Manual.

Once the data files for all 54 tests are available, the provided two spreadsheets can be used to compile the results and produce the accuracy measures for each validation quadrant and measurement direction. The spreadsheets produces accuracy results for each measurement distance and direction in a single table. A spreadsheet is provided for Y-axis movement and another for Z-axis movement. The spreadsheets should therefore be used six times to get values for the three measurement distances and two directions.

Errors in measurement from the CIV system are calculated as the difference between the translation recorded for the center target with respect to the user selected axis system and the gage block certified length. The translation of the center target is calculated as the vector distance between the 3D coordinates of the center target before a gage block is inserted and the coordinates of the target after the gage block is inserted. Any movement of the gage block device will be added to the translation of the target within the device. ***It is therefore critical not to bump or move the device while inserting or removing a gage block.***

Sample output tables of the spreadsheets described in the next section are provided in **Table 4-1** to **Table 4-6** (end of document) for three measurement distances, i.e., 40ft, 70ft and 110ft and in two translation directions: Y-axis and Z -axis direction.

4.3 Included Spreadsheets for Calculating Errors

As described in Section 4.1.1, a test with a unique project name will be created and the 3-D locations of each of the selected targets with respect to user-selected reference axis are stored in a .csv file in each of the project/test folder. Two template spreadsheets are provided that can be populated by copying coordinates from each test to deliver an accuracy comparison table such as those shown in **Table 4-1** to **Table 4-6** (end of document). The template spreadsheets are provided in the same directory as the User Manual and this Validation Manual, in a folder that has a shortcut on the Desktop screen. The template spreadsheets will deliver a table that includes the accuracy measures for all nine quadrants for a given distance and direction of translation. In all and for the entire measurement volume, the templates must be used six times to produces six tables such as **Table 4-1** to **Table 4-6**.

The following steps describe how to populate a template spreadsheet for one distance and measurement direction. Repeat these steps starting with a new template file for all six combinations of distance measurement distance.

- 1- For each distance and direction of measurement, open the file [UserCoordXYZ.csv](#) that is in each project folder using any spreadsheet program (**Figure 4-12**). Nine tests, one for each quadrant, should be opened. For example, open the [UserCoordXYZ.csv](#) inside the project/test folder [ValidationTest_date_40ft_1_Y](#) to [ValidationTest_date_40ft_9_Y](#) (named according to the naming scheme offered in Section 4.1, for a 40ft distance Y-direction, quadrants 1 to 9).

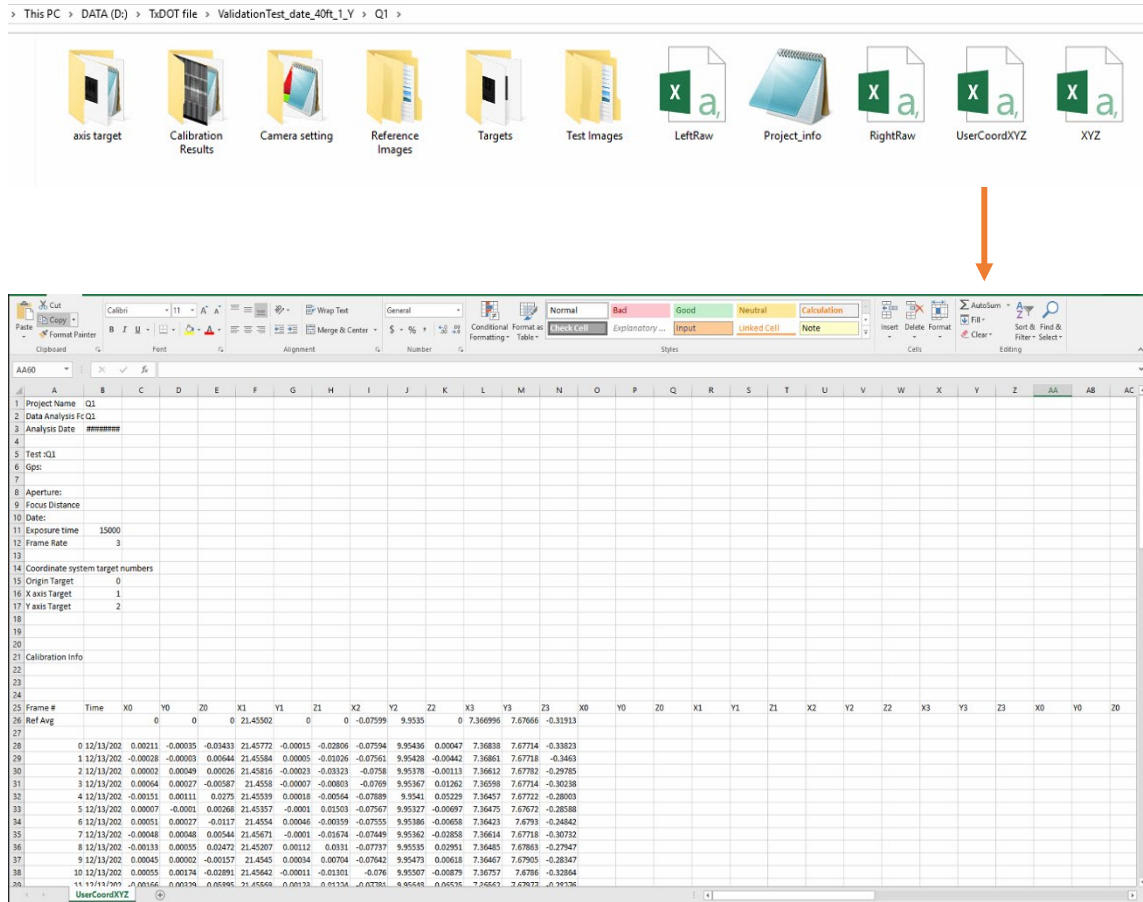

Figure 4-12: Folder structure showing data and images for quadrant 1 for validation test in Y-direction at 40 feet measurement distance

- 2- Copy the entire data sheet from the [UserCoordXYZ.csv](#) files to the supplied spreadsheet template file, which contains separate sheets named Q1 through Q9 for each of the quadrants; as illustrated in **Figure 4-13**.

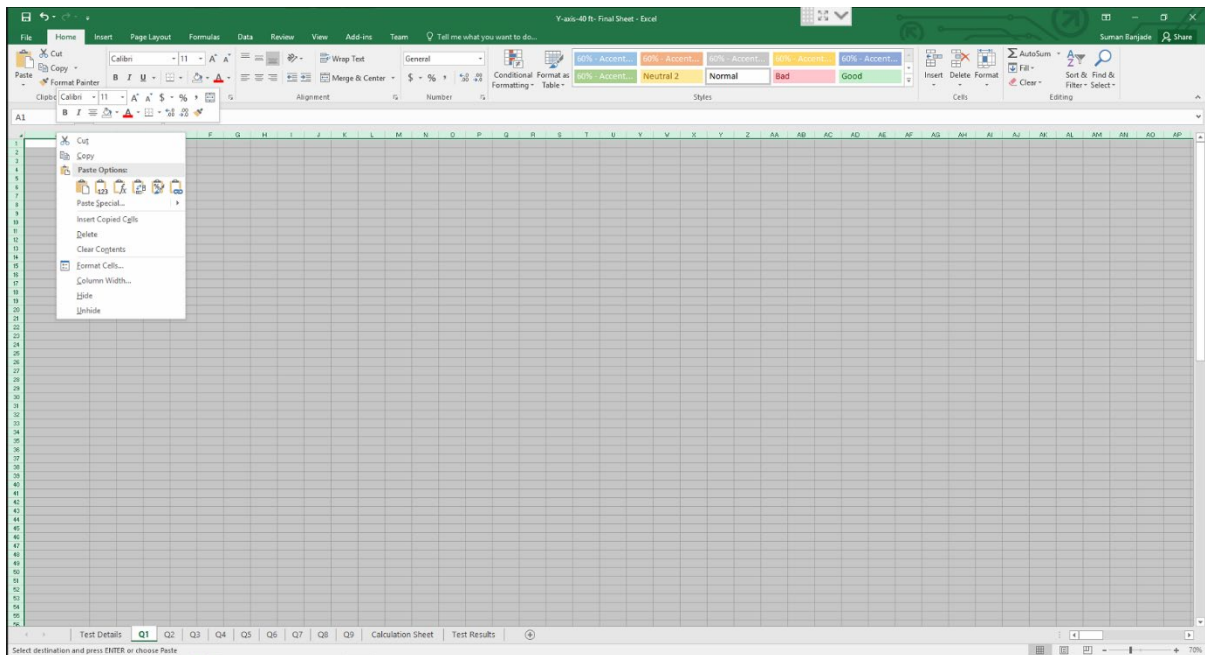
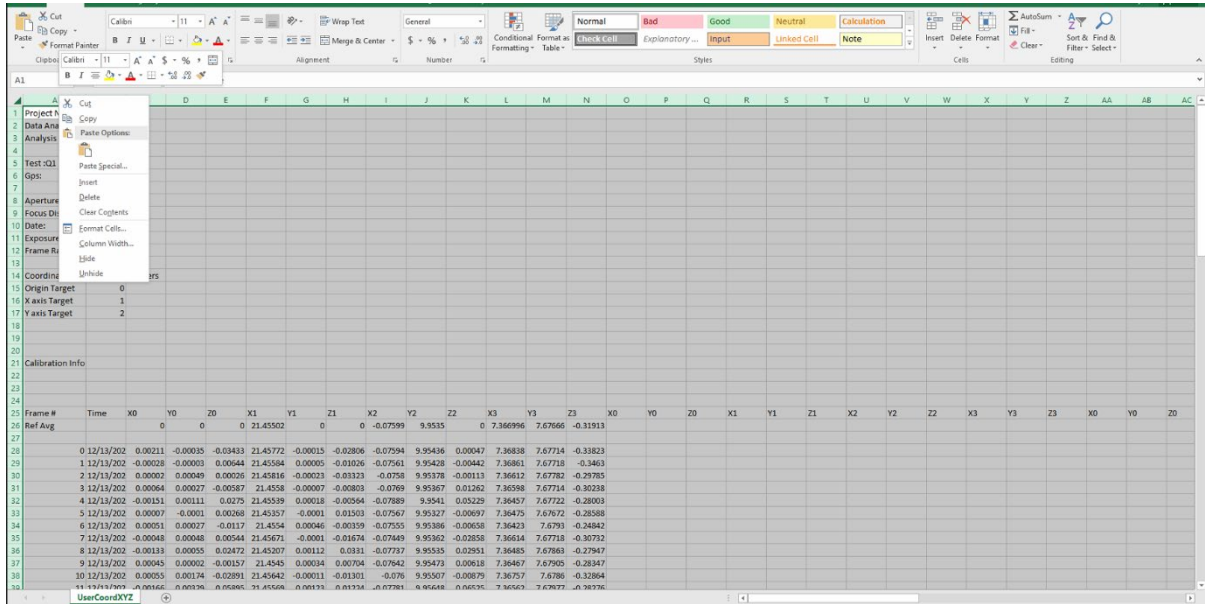

Figure 4-13: Copying the test data from test file to main spreadsheet for validation calculation

- 3- If not done previously while tests were being conducted, in the sheet named “Test Details”, enter the number of the targets used for the user coordinate system and the target number for the target that translated (Figure 4-14). Then enter the reference

frame numbers at which you paused and restarted a test to insert a gage block, as illustrated in Figure 4-14. Cells where input is required are highlighted in yellow.

Distance	70 feet	Reference Axis Target		Direction	Y
	Origin	X-axis	Y-axis	Center Target	
Target Number	0	1	2	3	
Quadrant Number	Image Quadrant	Gage Block Size (inch)	Frame Start	Frame End	
1	Top Left	0	0	29	
		0.75	30	59	
		2	60	91	
2	Middle Left	0	0	31	
		0.75	32	59	
		2	60	91	
3	Bottom Left	0	0	31	
		0.75	32	61	
		2	62	90	
4	Top Center	0	0	30	
		0.75	31	60	
		2	61	110	
5	Middle Center	0	0	29	
		0.75	30	59	
		2	60	90	
6	Bottom Center	0	0	31	
		0.75	32	61	
		2	62	91	
7	Top Right	0	0	31	
		0.75	32	60	
		2	61	91	
8	Middle Right	0	0	31	
		0.75	32	61	
		2	62	92	
9	Bottom Right	0	0	30	
		0.75	31	60	
		2	61	87	

Figure 4-14: Sample data entry in “Test Details”

- Once all the 9 excel sheet data is copied to the spreadsheet and the reference frame numbers entered, all the accuracy calculations are automatically generated in the sheet “Calculation Sheet” (Figure 4-15), and presented in a summarized fashion in the sheet named “Test Results” (Figure 4-16).

Quadrant Number	Image Quadrant	Gage Block Size (inch)	Frame Size	Frame Error	Location of Error Target from reference position	Error (inch)	Mean Absolute Error (inch)
1	Left Top						
2	Middle Left						
3	Bottom Left						
4	Top Center						
5	Middle Center						
6	Bottom Center						
7	Top Right						
8	Middle Right						
9	Bottom Right						
Overall Mean Absolute Error						0	
Standard Deviation						#DIV/0!	
Co-efficient of Variance(C.O.V),%						#DIV/0!	

Figure 4-15: Sample picture of “Calculation Sheet”

Quadrant Number	Image Quadrant	Gage Block Size (inch)	Error(inch)	Mean Absolute Error (inch)
1	Left Top	0	0	0
2	Middle Left	0	0	0
3	Bottom Left	0	0	0
4	Top Center	0	0	0
5	Middle Center	0	0	0
6	Bottom Center	0	0	0
7	Top Right	0	0	0
8	Middle Right	0	0	0
9	Bottom Right	0	0	0
Overall Mean Absolute Error				0
Standard Deviation				0
Co-efficient of Variance(C.O.V),%				#DIV/0!

Figure 4-16: Sample picture of “Test Results” sheet

Warning: Do not change any cells in the spreadsheet other than the quadrant sheet and the cells in which the reference frame numbers are entered. Changes made in other cells could result errors.

4.4 Validation Test Output

The following tables show sample validation test outputs for the entire measurement volume for a bridge calibration. In all, six tables are obtained for the two translation directions and three measurement distances selected (i.e., 40 feet, 70 feet and 110 feet).

Table 4-1: Validation Test Results at 40ft measurement distance and Y-direction

Quadrant Number	Image Quadrant	Gage Block Size (inch)	Error(inch)	Mean Absolute Error (inch)
1	Left Top	0	0	0.01667685
		0.75	-0.01146447	
		2	-0.02188924	
2	Middle Left	0	0	0.01196305
		0.75	-0.00673878	
		2	-0.01718733	
3	Bottom Left	0	0	0.0128862
		0.75	-0.00830729	
		2	-0.01746511	
4	Top Center	0	0	0.01599644
		0.75	-0.01207438	
		2	-0.0199185	
5	Middle Center	0	0	0.01345144
		0.75	-0.01265534	
		2	-0.01424754	
6	Bottom Center	0	0	0.01079724
		0.75	-0.00725097	
		2	-0.01434351	
7	Top Right	0	0	0.00870353
		0.75	-0.00950878	
		2	-0.00789829	
8	Middle Right	0	0	0.01890415
		0.75	-0.01205648	
		2	-0.02575182	
9	Bottom Right	0	0	0.01068556
		0.75	-0.00653047	
		2	-0.01484065	
Overall Mean Absolute Error			0.013340496	
Standard Deviation			0.003283936	
Co-efficient of Variance (C.O.V), %			24.6162949	

Table 4-2: Validation Test Results at 40ft measurement distance and Z-direction

Quadrant Number	Image Quadrant	Gage Block Size (inch)	Error(inch)	Mean Absolute Error (inch)
1	Left Top	0	0	0.00766995
		0.75	0.00301635	
		2	-0.0123235	
2	Middle Left	0	0	0.03199757
		0.75	-0.0123604	
		2	-0.0516347	
3	Bottom Left	0	0	0.04190878
		0.75	-0.0221562	
		2	0.06166134	
4	Top Center	0	0	0.01584433
		0.75	0.00617025	
		2	-0.0255184	
5	Middle Center	0	0	0.01655888
		0.75	-0.0101085	
		2	-0.0230093	
6	Bottom Center	0	0	0.04592455
		0.75	-0.0409244	
		2	-0.0509247	
7	Top Right	0	0	0.01970823
		0.75	0.03171567	
		2	0.0077008	
8	Middle Right	0	0	0.01796833
		0.75	-0.0032135	
		2	-0.0327231	
9	Bottom Right	0	0	0.01355293
		0.75	-0.0001032	
		2	-0.0270026	
Overall Mean Absolute Error			0.023459286	
Standard Deviation			0.013300552	
Co-efficient of Variance (C.O.V), %			56.69632043	

Table 4-3: Validation Test Results at 70ft measurement distance and Y-direction

Quadrant Number	Image Quadrant	Gage Block Size (inch)	Error(inch)	Mean Absolute Error (inch)
1	Left Top	0	0	0.00160232
		0.75	-0.00315067	
		2	-5.3979E-05	
2	Middle Left	0	0	0.007504
		0.75	-0.00826299	
		2	-0.006745	
3	Bottom Left	0	0	0.0040763
		0.75	-0.00363081	
		2	-0.00452178	
4	Top Center	0	0	0.00120219
		0.75	-0.00225919	
		2	-0.00014519	
5	Middle Center	0	0	0.003666
		0.75	-0.00378367	
		2	-0.00354833	
6	Bottom Center	0	0	0.00260337
		0.75	0.003593542	
		2	0.001613208	
7	Top Right	0	0	0.0023592
		0.75	-0.00096509	
		2	-0.00375331	
8	Middle Right	0	0	0.0031793
		0.75	-0.00279319	
		2	-0.00356541	
9	Bottom Right	0	0	0.00099232
		0.75	-0.0010933	
		2	-0.00089134	
Overall Mean Absolute Error			0.003020555	
Standard Deviation			0.001990622	
Co-efficient of Variance (C.O.V), %			65.90252855	

Table 4-4: Validation Test Results at 70ft measurement distance and Z-direction

Quadrant Number	Image Quadrant	Gage Block Size (inch)	Error(inch)	Mean Absolute Error (inch)
1	Left Top	0	0	0.04637769
		0.75	-0.0216157	
		2	-0.0711396	
2	Middle Left	0	0	0.10040409
		0.75	0.12274936	
		2	0.07805882	
3	Bottom Left	0	0	0.14098
		0.75	-0.0021982	
		2	0.27976178	
4	Top Center	0	0	0.07123004
		0.75	-0.0574186	
		2	-0.0850415	
5	Middle Center	0	0	0.04532516
		0.75	0.05092	
		2	0.03973032	
6	Bottom Center	0	0	0.03622839
		0.75	-0.0422042	
		2	-0.0302526	
7	Top Right	0	0	0.10176668
		0.75	0.10820774	
		2	0.09532562	
8	Middle Right	0	0	0.04233853
		0.75	-0.0423805	
		2	-0.0422966	
9	Bottom Right	0	0	0.04071712
		0.75	0.04193496	
		2	0.03949929	
Overall Mean Absolute Error			0.069485302	
Standard Deviation			0.036913491	
Co-efficient of Variance (C.O.V), %			53.12417143	

Table 4-5: Validation Test Results at 110ft measurement distance and Y-direction

Quadrant Number	Image Quadrant	Gage Block Size (inch)	Error(inch)	Mean Absolute Error (inch)
1	Left Top	0	0	0.00320002
		0.75	-0.00064165	
		2	0.0057584	
2	Middle Left	0	0	0.00965356
		0.75	0.006493333	
		2	0.012813796	
3	Bottom Left	0	0	0.00225942
		0.75	0.000605934	
		2	0.003912903	
4	Top Center	0	0	0.00217338
		0.75	-0.00409346	
		2	-0.00025329	
5	Middle Center	0	0	0.00896798
		0.75	-0.00881273	
		2	-0.00912323	
6	Bottom Center	0	0	0.00709851
		0.75	0.002497107	
		2	0.011699919	
7	Top Right	0	0	0.01205224
		0.75	0.006087241	
		2	-0.01801724	
8	Middle Right	0	0	0.00715338
		0.75	0.00948257	
		2	-0.00482419	
9	Bottom Right	0	0	0.00400739
		0.75	-0.00034084	
		2	0.00767394	
Overall Mean Absolute Error			0.006285098	
Standard Deviation			0.003553835	
Co-efficient of Variance (C.O.V), %			56.54382173	

Table 4-6: Validation Test Results at 110ft measurement distance and Z-direction

Quadrant Number	Image Quadrant	Gage Block Size (inch)	Error(inch)	Mean Absolute Error (inch)
1	Left Top	0	0	0.2204134
		0.75	-0.2874579	
		2	-0.1533689	
2	Middle Left	0	0	0.22352101
		0.75	-0.2712197	
		2	-0.1758224	
3	Bottom Left	0	0	0.06430296
		0.75	-0.0494349	
		2	-0.079171	
4	Top Center	0	0	0.21148137
		0.75	-0.1891679	
		2	-0.2337948	
5	Middle Center	0	0	0.05121298
		0.75	-0.0231215	
		2	0.07930443	
6	Bottom Center	0	0	0.12472287
		0.75	-0.1507569	
		2	-0.0986889	
7	Top Right	0	0	0.10132732
		0.75	-0.131871	
		2	0.07078364	
8	Middle Right	0	0	0.05100869
		0.75	-0.0948365	
		2	0.00718088	
9	Bottom Right	0	0	0.25543581
		0.75	-0.3952578	
		2	-0.1156138	
Overall Mean Absolute Error			0.144825158	
Standard Deviation			0.082862193	
Co-efficient of Variance (C.O.V), %			57.21533085	