



---

# Integrated Prioritization Method for Active and Passive Highway-Rail Crossings

**Technical Report 0-6642-1**  
Cooperative Research Program

---

UNIVERSITY OF TEXAS AT SAN ANTONIO  
DEPARTMENT OF CIVIL AND ENVIRONMENTAL ENGINEERING  
SAN ANTONIO, TEXAS 78249

TEXAS A&M TRANSPORTATION INSTITUTE  
COLLEGE STATION, TEXAS 77843-3135

in cooperation with the  
Federal Highway Administration and the  
Texas Department of Transportation  
<http://tti.tamu.edu/documents/0-6642-1.pdf>

1. Report No. FHWA/TX-12/0-6642-1		2. Government Accession No.		3. Recipient's Catalog No.	
4. Title and Subtitle INTEGRATED PRIORITIZATION METHOD FOR ACTIVE AND PASSIVE HIGHWAY-RAIL CROSSINGS				5. Report Date Published: January 2013	
				6. Performing Organization Code	
7. Author(s) Angela Jannini Weissmann, Jose Weissmann and Jaya Lakshmi Kunisetty—UTSA Jeffery Warner, Eun Sug Park, Srinivasa Sunkari, Annie Protopapas, and Steven Venglar—TTI				8. Performing Organization Report No. Report 0-6642-1	
9. Performing Organization Name and Address University of Texas at San Antonio, Department of Civil and Environmental Engineering San Antonio, Texas 78249-0668 and Texas A&M Transportation Institute College Station, Texas 77843-3135				10. Work Unit No. (TRAIS)	
				11. Contract or Grant No. Project 0-6642	
12. Sponsoring Agency Name and Address Texas Department of Transportation Research and Technology Implementation Office P.O. Box 5080 Austin, Texas 78763-5080				13. Type of Report and Period Covered Technical Report: September 2010 to August 2012	
				14. Sponsoring Agency Code	
15. Supplementary Notes Project performed in cooperation with the Texas Department of Transportation and the Federal Highway Administration. Project Title: Developing Warrants for Active Warning Devices at Low-Volume Highway-Rail Grade Crossings URL: <a href="http://tti.tamu.edu/documents/0-6642-1.pdf">http://tti.tamu.edu/documents/0-6642-1.pdf</a>					
16. Abstract This two-year research project developed a prioritization system for highway-rail at-grade crossings that addressed the following major concerns: (1) warrants to identify low-volume, passive crossings with risk factors; (2) a broader priority index that considers more variables than the original index; (3) warranting thresholds that remain valid with changes in data; and (4) a prioritization methodology capable of properly prioritizing the warranted passive crossings over high-volumes active crossings. The prioritization system combines a revised priority index based on a newly developed crash prediction equation, warrants for active warning devices at passive crossings, and a passive crossing prioritization index based on Utility Theory principles. The warranting threshold are defined in terms of cumulative percentiles rather than fixed numbers to ensure reliability as data changes. The warrants and prioritization indices were integrated into a systematic prioritization methodology capable of a generating priority list that assigns top priorities to crossings with risk factors in spite of low volumes. The deliverables will facilitate highway-rail crossing management in Texas and ensure proper consideration of low-volume crossings when applying funding mechanisms such as Section 130 funds.					
17. Key Words Highway-rail crossings, rail crossing safety, rail crossing management system, project prioritization, accident prediction, warrants.			18. Distribution Statement No restrictions. This document is available to the public through NTIS: National Technical Information Service Alexandria, Virginia <a href="http://www.ntis.gov">http://www.ntis.gov</a>		
19. Security Classif. (of this report) Unclassified		20. Security Classif. (of this page) Unclassified		21. No. of Pages 266	22. Price





## **Integrated Prioritization Method for Active and Passive Highway-Rail Crossings**

### The University of Texas at San Antonio

Angela Jannini Weissmann, Ph.D. Research Associate

Jose Weissmann, Ph.D., P.E. Professor of Civil Engineering

Jaya Lakshmi Kunisetty, M.Sc. Research Assistant

### Texas A&M Transportation Institute

Jeffery Warner, Associate Transportation Researcher

Eun Sug Park, Ph.D, Research Scientist

Srinivasa Sunkari, P.E., Research Engineer

Annie Protopapas, Ph.D., P.E. Associate Research Engineer

Steven Venglar, P.E., Research Engineer

Report 0-6642-1

Project 0-6642: Developing Warrants for Active Warning Devices at Low-Volume Highway-Rail Grade Crossings

Performed in cooperation with the  
Texas Department of Transportation  
and the  
Federal Highway Administration

Published: January 2013

The University of Texas at San Antonio  
Department of Civil and Environmental Engineering  
One UTSA Circle, San Antonio, Texas 78249-0668



## **DISCLAIMER**

This research was performed in cooperation with the Texas Department of Transportation (TxDOT) and the Federal Highway Administration (FHWA). The contents of this report reflect the views of the authors, who are responsible for the facts and the accuracy of the data presented herein. The contents do not necessarily reflect the official view or policies of the FHWA or TxDOT. This report does not constitute a standard, specification, or regulation.

**NOT INTENDED FOR CONSTRUCTION, BIDDING, OR PERMIT PURPOSES**

The engineer in charge of the project was José Weissmann, P.E., Texas #. 79815

## **ACKNOWLEDGMENTS**

This project was conducted in cooperation with TxDOT and FHWA. The authors thank the persons listed below for their technical guidance and administrative and editorial support.

### **TxDOT Project Monitoring Committee**

Darin Kosmak, Rail Division, Project Director  
Troy Daniel, Lubbock District, Project Advisor  
Juanita Daniels-West, Tyler District, Project Advisor  
Roy Parikh, Fort Worth District, Project Advisor  
David Valdez, Traffic Operations Division, Project Advisor  
Marvin Wright, Rail Division, Project Advisor  
Wade Odell, Research and Technology Implementation Office, Research Engineer  
Sandra Kaderka, Research and Technology Implementation Office, Contract Specialist

### **UTSA**

Steven Stewart, OIT  
Dr. Mijia Yang, former UTSA professor

### **TTI**

Joanna Dickens, Associate Research Editor  
Michelle Jones, Research Publications Specialist

# TABLE OF CONTENTS

<b>CHAPTER 1 INTRODUCTION</b> .....	<b>1-1</b>
<b>Background</b> .....	<b>1-1</b>
<i>Highway-Rail Crossings Safety</i> .....	<i>1-1</i>
<i>The Texas Priority Index</i> .....	<i>1-2</i>
<b>Project Objectives and Approach</b> .....	<b>1-4</b>
<b>Report Organization</b> .....	<b>1-5</b>
<b>CHAPTER 2 LITERATURE REVIEW</b> .....	<b>2-1</b>
<b>Background</b> .....	<b>2-1</b>
<b>State Department of Transportation and Local Agency Use of Index Variables</b> .....	<b>2-2</b>
<b>Crash Prediction Contribution of Priority Index Variables</b> .....	<b>2-4</b>
<b>Florida’s Crash Prediction Equation</b> .....	<b>2-6</b>
<b>Synthesis of Spanish and French Practices</b> .....	<b>2-8</b>
<i>Exposure</i> .....	<i>2-8</i>
<i>Sight Distance</i> .....	<i>2-8</i>
<i>Grade Separation</i> .....	<i>2-9</i>
<i>Spain’s Minimum Protection for At-Grade Crossings</i> .....	<i>2-10</i>
France’s Minimum Standards .....	<i>2-10</i>
<i>France’s Guidelines for Improving Active Crossings</i> .....	<i>2-12</i>
<i>Conclusions</i> .....	<i>2-13</i>
<b>Variables to Investigate as Part of Priority Index Statistical Analysis</b> .....	<b>2-13</b>
<b>CHAPTER 3 RESEARCH DATABASE</b> .....	<b>3-1</b>
<b>Overview</b> .....	<b>3-1</b>
<b>Data Updates</b> .....	<b>3-1</b>
<b>Research Database Structure</b> .....	<b>3-2</b>
<i>Priority List</i> .....	<i>3-3</i>
<i>Comparisons among Data Sources</i> .....	<i>3-3</i>
<b>Conclusion</b> .....	<b>3-4</b>
<b>CHAPTER 4 TEXAS PRIORITY INDEX STATISTICAL ANALYSIS AND REVISED FORMULATION</b> .....	<b>4-1</b>
<b>Data</b> .....	<b>4-1</b>
<b>Steps for Creating TxRAIL 2011 Base Data Table</b> .....	<b>4-1</b>
<b>Crash Analysis and Prediction Models</b> .....	<b>4-7</b>
<i>Negative Binomial Regression Analysis for 10 Year Aggregated Crashes</i> .....	<i>4-8</i>
<i>Negative Binomial Regression Analysis for 5 Year Aggregated Crashes</i> .....	<i>4-11</i>



Revised Texas Priority Index.....	4-13
Assessment of Performance and Comparison with Existing TPI.....	4-15
<b>CHAPTER 5 WARRANTS FOR PASSIVE CROSSINGS .....</b>	<b>5-1</b>
<b>Warrants’ Objectives and Underlying Principles.....</b>	<b>5-1</b>
<b>Research Approach.....</b>	<b>5-1</b>
<b>Analysis of Existing Methodologies.....</b>	<b>5-2</b>
<i>Idaho Department of Transportation.....</i>	<i>5-3</i>
Description.....	5-3
Implementation.....	5-4
Conclusions.....	5-5
<i>Federal Highway Administration .....</i>	<i>5-5</i>
Description and Implementation.....	5-5
Conclusions.....	5-7
<i>Illinois Department of Transportation.....</i>	<i>5-8</i>
Description.....	5-8
Implementation.....	5-10
Conclusions.....	5-13
<i>Florida Department of Transportation Methodology.....</i>	<i>5-13</i>
Description.....	5-13
Implementation.....	5-15
Conclusions.....	5-16
<i>Conclusions and Recommendations .....</i>	<i>5-17</i>
<b>Texas Warrants for Passive Crossings.....</b>	<b>5-18</b>
<i>Overview .....</i>	<i>5-18</i>
<i>The Percentile Threshold Concept.....</i>	<i>5-19</i>
<i>Non-Qualification Criteria and the Eligible Data Set.....</i>	<i>5-20</i>
<i>Warrants for Passive Crossings.....</i>	<i>5-23</i>
Introduction.....	5-23
Correct Percentile Calculation.....	5-23
Average Daily Traffic (AADT).....	5-25
Total Daily Trains.....	5-26
Exposure.....	5-27
Warrant 1: Past Five-Year Crashes $\geq 1$ .....	5-29
Warrant 2: Trains per Day $\geq 95\%$ Cumulative Percentiles for Urban and Rural Areas.....	5-30
Warrant 3: School Buses per Day $\geq 94\%$ Cumulative Percentile of the Subset of Eligible Crossings that Serve School Buses.....	5-30
Warrant 4: Total Number of Tracks $\geq 2$ .....	5-30
Warrant 5: Train Speed $\geq 49$ mph and AADT $\geq 75\%$ Cumulative Percentile in Urban/Rural Areas.....	5-30
Warrant 6: Either AADT or Exposure $\geq 95\%$ Percentile for Rural Areas and $\geq 90\%$ Percentile for Urban Areas.....	5-33
Warrant 7: Average Number of Heavy Vehicles per Day $\geq 95\%$ Percentile.....	5-33

Warrant 8: Passenger Trains/Day $\geq 1$ .....	5-34
Warrant 9: Presence of a Stopped Sight Distance Obstruction ( $0 < \text{Stopobs}_1 < 8$ or $0 < \text{Stopobs}_2 < 8$ ) .....	5-34
Warrant 10: Highway Parallel to and less than 75 ft from Tracks when Other Factors Are Present .....	5-35
<b>Summary of Results, Conclusions and Recommendations .....</b>	<b>5-39</b>
<b>CHAPTER 6 TEXAS PASSIVE CROSSINGS INDEX.....</b>	<b>6-1</b>
<b>Background and Objective .....</b>	<b>6-1</b>
<i>Objectives of a Passive Crossings Index .....</i>	<i>6-1</i>
<i>Utility Theory Concepts and Their Application to Highway-Railroad Crossings...</i>	<i>6-2</i>
<b>TPCI Formulation .....</b>	<b>6-4</b>
<i>Overview .....</i>	<i>6-4</i>
<i>Attribute Utilities and Percentiles.....</i>	<i>6-5</i>
Definitions for Numeric and Categorical Variables .....	6-5
Crashes in the Past Five Years.....	6-6
Total Trains per Day .....	6-6
School Buses per Day.....	6-8
Total Number of Tracks.....	6-9
Train Speed .....	6-10
Annual Average Daily Traffic (AADT) .....	6-10
Heavy Vehicles per Day .....	6-10
Highway Speed Limit .....	6-10
Nearby Intersection and Nearby Traffic Signal .....	6-11
Approach Angle.....	6-12
Profile Irregularities (Dips and Humps) .....	6-12
Sight Distance Obstruction .....	6-12
<i>TPCI Variables' Weights .....</i>	<i>6-12</i>
<i>Methodology .....</i>	<i>6-13</i>
Step 1: Pairwise Comparison Matrix .....	6-14
Step 2: Consistency Check.....	6-14
Step 3: Normalization .....	6-15
<b>Results, Conclusions, and Recommendations .....</b>	<b>6-16</b>
<b>CHAPTER 7 INTEGRATED PRIORITIZATION METHODOLOGY .....</b>	<b>7-1</b>
<b>Introduction and Objective.....</b>	<b>7-1</b>
<b>Acceptability Criteria for Integrated Prioritization Methods.....</b>	<b>7-1</b>
<b>Alternatives Based on Overall <math>TPI_{rev}</math> Priorities.....</b>	<b>7-2</b>
<i>Description.....</i>	<i>7-2</i>
<i><math>TPI_{rev}</math> Sensitivity Analysis .....</i>	<i>7-3</i>
<i>Results and Conclusions .....</i>	<i>7-6</i>
<b>Alternatives Based on Adjusted <math>TPI_{rev}</math> Formulas.....</b>	<b>7-7</b>
<i>Adjusted <math>TPI_{rev}</math>.....</i>	<i>7-8</i>

<i>Intermediate Variable <math>\mu</math></i> .....	7-9
<b>Summary of Findings</b> .....	<b>7-11</b>
<b>Recommended Prioritization Methodology</b> .....	<b>7-12</b>
<i>Overview</i> .....	7-12
<i>Development and Implementation</i> .....	7-13
Step 1—Estimate the size and composition of the top priorities.....	7-13
Step 2—Prioritize active crossings .....	7-13
Step 3—Prioritize warranted passive crossings.....	7-14
Step 4—Build the top of the Integrated Prioritization List.....	7-15
Step 5—Prioritize the remaining crossings.....	7-16
Implementation Recommendations .....	7-16
<b>Results, Conclusions and Recommendations</b> .....	<b>7-16</b>
<i>Results</i> .....	7-16
<i>Summary of Conclusions and Recommendations</i> .....	7-19
<b>REFERENCES</b> .....	<b>R1</b>
<b>APPENDIX 1 ANNOTATED BIBLIOGRAPHY</b> .....	<b>A1</b>
<b>APPENDIX 2 COMPARISONS AMONG DATA SOURCES</b> .....	<b>A2</b>
<b>APPENDIX 3 PROJECT WORKSHOP AND SURVEY</b> .....	<b>A3</b>

## LIST OF TABLES

### CHAPTER 1

Table 1-1 Illustrative Example of Priorities with the Original TPI.....	1-3
---	-----

### CHAPTER 2

Table 2-1 Variables Used in Select Priority Indices .....	2-3
Table 2-2 State DOT Use of Variables in Priority Index Formulae .....	2-4
Table 2-3 Significance of Variables According to Statistical Analyses Reviewed .....	2-5
Table 2-4 Spain’s Standards for Minimum At-Grade Crossing Protection (Ref. 25) .....	2-10
Table 2-5 France’s Four Categories of At-Grade Crossings (Ref.15) .....	2-11
Table 2-6 Rating of Different Variables for Upgrade from Passive to Flashers and Passive to Gates .....	2-14

### CHAPTER 3

No tables.

### CHAPTER 4

Table 4-1 Variables Captured from GxForm and tblCONTROL.....	4-1
Table 4-2 Percentage of Missing Data for the Variables in the Final Table for 9,741 Crossings.....	4-5
Table 4-3 Estimates of Regression Coefficients of Negative Binomial Regression Models Applied to 10 year Aggregated Crash Frequency Data from 6,807 Crossings with Non-Missing Predictor Variables.....	4-9

Table 4-4 Estimates of Coefficients of Negative Binomial Regression Models with Significant Variables Applied to 10 year Aggregated Crash Frequency Data from 9,108 Crossings.....	4-10
Table 4-5 Estimates of Coefficients of Negative Binomial Regression Models with Significant Variables Applied to 5 year Aggregated Crash Frequency Data from 9,108 Crossings.....	4-12
Table 4-6 Percentage of 2011 Crashes Captured by Top Proportions of Ranked Crossings.....	4-16

## CHAPTER 5

Table 5-1 ID-DOT Definitions of Low, Medium, and High Values (Ref. 10).....	5-4
Table 5-2 Results of the FHWA Methodology.....	5-7
Table 5-3 Illi-DOT Traffic Factors (Ref. 11).....	5-9
Table 5-4 Illi-DOT Component Factors (Ref. 11).....	5-9
Table 5-5 Illi-DOT Modification: Results.....	5-11
Table 5-6 Observed Accidents versus Illi-DOT's ECF Estimates.....	5-12
Table 5-7 Texas Passive Crossings Meeting Florida Qualification Threshold.....	5-16
Table 5-8 Summary of Variables Used by the Methodologies Analyzed.....	5-18
Table 5-9 Non-Qualification Criteria.....	5-22
Table 5-10 Variable UrbanRural (2010 Data).....	5-23
Table 5-11 Acceptable and Unacceptable Percentile Calculations.....	5-25
Table 5-12 Crossings Meeting Warrant 5 by Train Speed Threshold (2011 Data).....	5-31
Table 5-13 Cross-Tabulation of Train Speed and Track Signals.....	5-32
Table 5-14 Crossings Meeting Warrant 7 Variations (2011 Data).....	5-34
Table 5-15 Variables StopObs1 and StopObs2 Values.....	5-35
Table 5-16 Candidate Variables Analyzed for Warrant 10.....	5-37
Table 5-17 Examples of Warrant 10 Investigation.....	5-38
Table 5-18 Summary of the Warranting Procedure.....	5-39
Table 5-19 Warrants and Detailed Results.....	5-41

## CHAPTER 6

Table 6-1 AADT Quantiles in the Warranted Set.....	6-2
Table 6-2 TPCI Variables and Weights.....	6-5
Table 6-3 Five-Year Crashes Utilities/Cumulative Percentiles.....	6-6
Table 6-4 Total Trains per Day Utilities/Cumulative Percentiles.....	6-6
Table 6-5 School Buses per Day Utilities/Cumulative Percentiles.....	6-8
Table 6-6 Utilities for Nearby Intersections and Nearby Signals.....	6-12
Table 6-7 Original Survey Scores.....	6-13
Table 6-8 AHP Fundamental Scale for Pairwise Comparisons.....	6-14
Table 6-9 Pairwise Comparison Matrix.....	6-15
Table 6-10 Final Weights.....	6-16
Table 6-11 Examples of Crossings with Risk Factors and Low Priorities with the Original TPI.....	6-18

## CHAPTER 7

Table 7-1 Basic Statistics of the Revised TPI.....	7-4
Table 7-2 Top of the Priority Lists Generated with TPIrev and Original TPI.....	7-6
Table 7-3 Crashes in the 2007–2011 Period.....	7-7

Table 7-4 Top 300 Crossings with Tentative TPIrev Adjustments.....	7-9
Table 7-5 Predicted Yearly Crash Probabilities and Observed 2011 Frequencies .....	7-9
Table 7-6 Quantiles of Predicted Crash Probabilities .....	7-10
Table 7-7 Warranted Crossings with Missing Index Data in File WP_BOTTOM .....	7-15
Table 7-8 Summary of the Integrated Top Priorities by Crossing Type.....	7-17
Table 7-9 Summary of the Integrated Top Priorities by Number of Crashes .....	7-17
Table 7-10 Summary of the Integrated Top Priorities by Number of Warrants Met .....	7-18
Table 7-11 Summary of Top Priorities by Contents .....	7-19

## **LIST OF FIGURES**

### **CHAPTER 1**

Figure 1-1 Crash Numbers and Incremental Changes at Texas Highway-Rail Crossings..	1-1
Figure 1-2 Crash Rate Historical Trends.....	1-2

### **CHAPTER 2**

Figure 2-1 Example of Active Protection in France .....	2-12
Figure 2-2 Fully Protected Crossing (Ref. 24).....	2-13
Figure 2-3 VMS in Protected Crossing (Ref. 24).....	2-13

### **CHAPTER 3**

Figure 3-1 Number of Crossings in Each Rail Database .....	3-2
--	-----

### **CHAPTER 4**

Figure 4-1 Distribution for 10-year Aggregated Accident Frequency.....	4-7
Figure 4-2 Distribution for 5-year Aggregated Accident Frequency.....	4-8
Figure 4-3 Distribution for 1-year (2011) Accident Frequency.....	4-15

### **CHAPTER 5**

Figure 5-1 Research Approach—Warrants .....	5-2
Figure 5-2 Observed and Estimated Crashes (Illinois DOT Method).....	5-12
Figure 5-3 Florida Safety Index .....	5-17
Figure 5-4 Overview of Warranting Procedure.....	5-21
Figure 5-5 AADT Cumulative Distribution (2010 Data).....	5-26
Figure 5-6 Cumulative Distribution of Daily Trains (2010 Data) .....	5-27
Figure 5-7 Exposure Cumulative Distribution (2010 Data).....	5-29
Figure 5-8 MUTCD Parallel Highway Advance Warning Signs.....	5-36
Figure 5-9 Number of Crossings Meeting Warrants.....	5-40
Figure 5-10 Number of Crossings Meeting Each Warrant .....	5-40

### **CHAPTER 6**

Figure 6-1 Concept of Attribute Utility.....	6-3
Figure 6-2 Total Number of Tracks Cumulative Percentiles .....	6-9
Figure 6-3 Utilities/Cumulative Percentiles of Train Speed .....	6-10
Figure 6-4 Cumulative Percentiles/Utilities of Heavy Vehicles per Day .....	6-11

Figure 6-5 TPCI Distributions for Warranted and Non-Warranted Crossings ..... 6-18

**CHAPTER 7**

Figure 7-1 Revised TPI and Number of 5-Year Crashes ..... 7-4  
Figure 7-2 Histograms of the 5% Highest TPIrev Values ..... 7-5  
Figure 7-3 Warranted Crossings by Number of Warrants Met..... 7-8  
Figure 7-4 Correlation between TPCI-Revised TPI and TPCI- $\mu$ ..... 7-11  
Figure 7-5 Top Priorities Contents by Number of Crashes..... 7-19

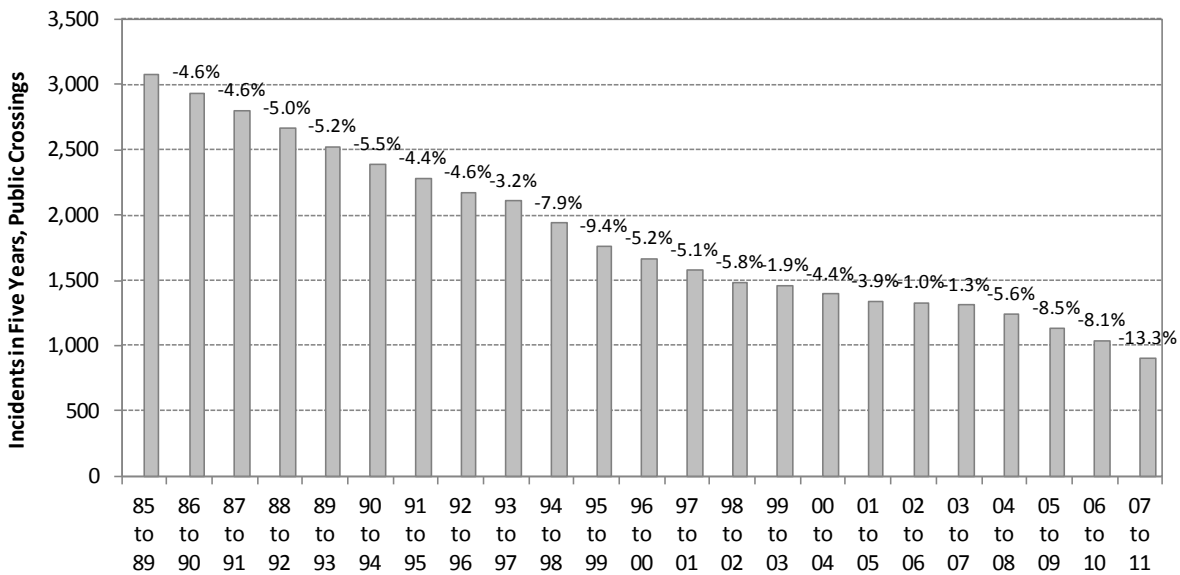


# CHAPTER 1 INTRODUCTION

## Background

### Highway-Rail Crossings Safety

The purpose of the national Highway-Rail Grade Crossing Safety Program (H-RGCP) is to reduce the risk and the number of crashes between vehicles and trains. Section 130 of Title 23 U.S.C. provides federal funds to improve safety at any public highway-rail at-grade crossing. Texas has been improving at-grade crossings since before inception of the Federal Highway Safety Act of 1973, which included a provision to fund warning devices at highway-rail grade crossings. As a result, incidents at Texas public crossings have been decreasing, as depicted in [Figure 1.1](#). The rate of change in crashes with respect to the previous five-year period is negative for all periods shown, ranging from -13.3 percent to -1.0 percent. Nevertheless, the total number of at-grade crossings in Texas has also been decreasing, so the safety levels at highway/rail crossings continue to be a concern.

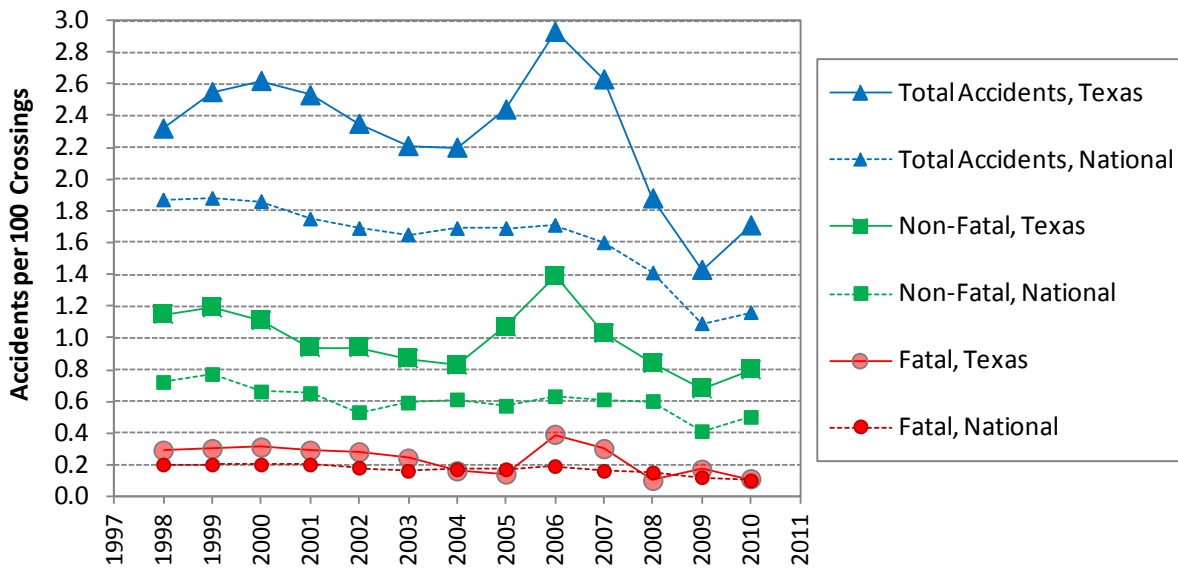


**Figure 1-1 Crash Numbers and Incremental Changes at Texas Highway-Rail Crossings**

Source: Federal Railroad Administration (Ref. 35)

As depicted in [Figure 1-2](#) (1999 to 2010), the yearly number of crashes per 100 crossings did not show a steady trend during the past 13 years, and remained higher than the national numbers. In this period, Texas had 1,357 crashes between trains and motorized vehicles, with 42.9 percent of them at passive crossings. For the 100 crossings with the highest crash frequencies, the crashes resulted in 126 deaths and 65 injuries in a total of 146 incidents (Ref. 29).





**Figure 1-2 Crash Rate Historical Trends**  
 Source: Federal Railroad Administration (Ref. 35)

A recent TxDOT report states that 812 (61 percent) of the 1,328 collisions between 2003 and 2007 occurred at active crossings (Ref. 29). In 229 of these 1,328 collisions it was reported that “active devices” were “interconnected with a nearby traffic control device” (Table 8, Appendix A of Ref. 29).

**The Texas Priority Index**

In order to utilize Section 130 funds, states are required to develop and maintain a method to prioritize crossings for improvements on a statewide basis. Texas utilizes a priority index that can be written as:

$$TPI = 0.001 AADT SchB T S P_f A^{1.15} \quad [1-1]$$

Where:

TPI = Texas Priority Index; the higher the TPI, the higher the priority for crossing upgrade.

AAADT = average daily vehicular traffic.

SchB = School bus factor, defined based on the daily number of school buses as follows:

- SchB =1 if daily school buses < 1
- SchB=1.2 if 1 ≤ daily school buses < 4
- SchB=1.6 if 4 ≤ daily school buses < 11
- SchB=1 if daily school buses ≥ 11

T = daily train traffic.

- S = maximum train speed for through trains or minimum speed for switching trains (mph).
- $P_f$  = protection factor: 0.10 for gates, 0.70 for mast flashers, 0.15 for cantilever flashes, and 1 for all others.
- A = number of crashes in the last five years (if A=0 use A=1).

This index was developed with the primary objective of ensuring that high-volume crossings would get top priority for funding, especially if there was a crash history. Now that most high-volume crossings have been protected, a new methodology capable of selecting low-volume (passive) crossings becomes necessary.

A brief analysis of the original TPI underscores a limitation common to all priority indices found in the literature (see [Chapter 2](#)); it is mathematically impossible for the same index to emphasize the crossing exposure (product of vehicular and train volumes) while simultaneously assigning high priorities to low-volume crossings with safety concerns. As a result, many agencies, including TxDOT, analyze active and passive crossings separately. [Table 1-1](#) illustrates this point using 15 hypothetical crossings assumed to serve 10 60 mph through trains per day and no school buses. Annual average daily traffic (AADT) varies.

**Table 1-1 Illustrative Example of Priorities with the Original TPI**

ROW#	AADT	Device	Crashes/5yrs	TPI	Priority
1	500	Crossbucks	9	3754	1
2	8,000	Mast flashers	0	3,360	2
3	500	Crossbucks	8	3,278	3
4	500	Crossbucks	7	2,811	4
5	500	Crossbucks	6	2,355	5
6	5,000	Mast flashers	0	2,100	6
7	500	Crossbucks	5	1,910	7
8	500	Crossbucks	4	1,477	8
9	3,000	Mast flashers	0	1,260	9
10	500	Crossbucks	3	1,061	10
11	2,500	Mast flashers	0	1,050	11
12	2,000	Mast flashers	0	840	12
13	500	Crossbucks	2	666	13
14	500	Crossbucks	1	300	14
15	500	Crossbucks	0	300	14

The priorities in the last column indicate that the original TPI depicted in [Equation 1-1](#) sorted the low-volume crossings logically in terms of number of crashes, but it also illustrates its emphasis on high-volume crossings. Rows 1, 2, and 3 indicate that the original TPI rates considers 8 crashes in a low-volume passive crossing less important than further improving a crash-free,

higher-volume active crossing. Considering that the maximum number of crashes per crossing rarely reaches 9 (see row 1), this clearly hazardous low-volume crossing would have practically no chance of being considered by a priority list based on the original index.

Similar comparisons are found throughout [Table 1-1](#). For example, should it really take more than a crash per year (row 5) for a 500-AADT crossing to receive a higher priority than a crash-free, active crossing because to greater vehicular traffic (row 6)? The first crossing is clearly more hazardous than the second. Passive crossings with one or two crashes (13<sup>th</sup> and 14<sup>th</sup> priorities) would have practically no chance of being placed on the top of a priority list based on the original TPI.

Another issue that also deserves revision is the underlying treatment of crashes. [Equation 1-1](#) makes no distinction between a crossing with no crashes and another with one crash (see variable “A”). This limitation is inherent to all multiplicative indices: zeroes cannot be properly considered. In TPI’s case, they are replaced by 1. While this difference may not have been significant back when the original index was developed, it is now: the number of incidents has been steadily dropping, as depicted in [Figure 1-1](#). For example, rows 14 and 15 in [Table 1-1](#) show two passive crossings with 14<sup>th</sup> priority: one receives the same priority as no crashes when all other factors are the same. Another example not present in [Table 1-1](#): a passive crossing with 10,000 vehicles per day, one train per day, and no crashes is probably safer than another passive crossing with 5 trains per day, 1,000 vehicles per day, and one crash. Nevertheless, the active crossing original TPI is twice as high as that of the passive crossing with the crash.

## **Project Objectives and Approach**

This basic issue had already been identified by TxDOT and was the motivation for this project: proper prioritization needs to consider passive crossings separately, through a combination of (1) a revised priority index that considers additional variables, (2) warrants to identify passive crossings that are candidates for upgrades, and (3) a methodology to prioritize warranted passive crossings that does not continue to place them at the bottom of the priority list. The implementable products developed by this project consist of:

- A methodology to extract a subset of passive crossings with risk factors, called the warranted set.
- A revised Texas Priority Index (TPI<sub>rev</sub>) based on adjusted crash predictions for all crossings, passive and active.
- The Texas Passive Crossings Index (TPCI), which ranks the warranted set based on an index that captures issues that are significant to passive crossings.
- An integrated prioritization methodology that assigns similar importance to active and passive crossings with risk factors.
- Implementation instructions and recommendations.

These products meet the technical objective of this project, which is to develop a methodology to prioritize passive crossings while at the same time ensuring that high-volume crossings continue to receive the careful analysis they deserve.

## **Report Organization**

This report has seven chapters and three appendices. [Chapter 1](#) is this *Introduction*. [Chapter 2](#), *Literature Review*, summarizes the principal findings of the literature review and discusses their relevance to the project. [Chapter 3](#), *Research Database*, discusses the available data sources and documents the development of the database used in this project's investigations. [Chapter 4](#), *Texas Priority Index Revision*, explains the revised Texas Priority Index (Rev-TPI) and discusses the results. [Chapter 5](#), *Warrants for Passive Crossings*, documents the development of the warranting procedure and discusses the warranted set and other results using the most recent data (2011). [Chapter 6](#), *Texas Passive Crossings Index (TPCI)* documents the development of the index developed in this project to rank the passive crossings, and discusses the results using the most recent data. [Chapter 7](#), *Integrated Prioritization Methodology*, discusses alternatives proposed for the developing the final priority list, and recommends the best approach to implement at TxDOT to automatically obtain a final priority list that balances active and passive crossings with risk factors, using variables and tables available as Access files currently embedded in TxDOT's TxRAIL database.

[Appendix 1](#) contains an annotated bibliography of the references reviewed by the research team during Task 1, Background Information. [Appendix 2](#) contains tables with comparisons among data sources used for the project analyses. [Appendix 3](#) contains the minutes of the workshop held in this project, where several important decisions were made in concert with the PMC, and the survey conducted during this workshop and utilized as guidance in this project.



## **CHAPTER 2 LITERATURE REVIEW**

This chapter discusses the literature in terms of how it relates to the priority index investigation. However, many of the same variables investigated for the priority index revision also pertain to the warrant investigation. Further discussion of the background review specific to the warrant investigation is included in [Chapter 4](#). [Appendix 1](#) includes the detailed annotated bibliography of the documents reviewed for this assessment.

### **Background**

Fundamental to the issue of how to formulate a procedure for calculating the crash risk at a highway-rail grade crossing (HRGC) is the development of criteria for determining how well such a procedure fulfills its function. Criteria for judging the usefulness of a grade crossing crash prediction equation (or process) were on the agenda of an expert panel workshop assembled as part of a research project in Missouri to reformulate that state's HRGC Exposure Index (ref. 19). The desired qualities agreed upon by the expert panel included:

- Accuracy of the model.
- Number of “difficult” variables (to collect).
- Explainability.
- Number of key variables.
- Inclusion of crossing control type.
- Number of variables for which data are not available.
- Number of total variables.
- Inclusion of weighting factors.

As revealed through a review of the list of criteria, the ideal HRGC relative risk model would accurately identify the level of relative risk of crashes at HRGCs; contain few or no variables for which data are not easily available; be easy to explain among those who use the index or even the general public; contain as many as possible important variables generally associated with crash risk at HRGCs; feature the type of control currently extant at crossings; contain few or no variables for which data are unavailable in state grade crossing inventory or other databases; contain as few variables as possible given other variable requirements; and incorporate weighting factors to (better) scale the importance of each variable in quantifying relative crash risk. Embedded in these criteria is a secondary list of what are considered key variables for establishing the relative crash risk at HRGCs. The contents of key variables list were also addressed by the expert panel and resulted in the following variables (ref. 19):

- Average Annual Daily Traffic (AADT).
- Number of passenger trains.

- Stopping sight distance (SD) vs. recommended SD.
- Approach SD vs. recommended SD.
- Train speed.
- Total number of trains.
- Speed of highway traffic.
- Number of quadrants where SD is restricted.
- Clearance time.

Not surprisingly, the list of variables assembled by the expert panel matches with the exposure variables (i.e., traffic and train volume), sight distance availability and speed factors common in the HRGC priority, or exposure indices used in states across the country.

### **State Department of Transportation and Local Agency Use of Index Variables**

Further information regarding the use of priority index variables around the country was identified through a literature review and contact with select transportation departments regarding their HRGC improvement prioritization process. [Table 2-1](#) shows the variables incorporated into the agency priority indices, including the existing Texas Priority Index.

As revealed through examination of the table, exposure variables (train and traffic volume), traffic control device type and crash history are common elements of priority indices discussed in the literature. Almost as common are the number of tracks and sight distance; again variables logically associated with crossing safety due to either increased crossing time and “second train” perception risk (number of tracks) or diminished capability of the approaching driver to perceive the risk of an oncoming train (sight distance). Less common variables include train type (passenger/freight), bus or special vehicle use of the crossing, train speed, approach grade, crossing angle, pedestrian volume, crossing condition (surface type, humped/not humped, etc.), road/track alignment (roadway paralleling the tracks), road surface, and highway type.

**Table 2-1 Variables Used in Select Priority Indices**

Index	Traffic Volume	Train Volume	Warning Device	Accidents	Number of Tracks	Sight Distance	Train Type	Bus\Special Vehicle	Train Speed	Approach Grade	Crossing Angle	Pedestrian Volume	Crossing Condition	Road/Track Alignment	Road Surface	Highway Type\Lanes	Highway Speed
Texas	✓	✓	✓*	✓				✓	✓								
USDOT	✓*	✓*	✓*	●	✓*		✓*		✓*						✓*	✓*	
Peabody Dimmick	✓	✓	✓*	●													
New Hampshire	✓	✓	✓*														
NCHRP	✓*	✓	✓*	●													
Florida	✓	✓	✓	●✓				✓	✓							✓	✓
Ohio				✓*	✓*	✓*			✓*	✓*	✓*						
Mississippi				✓		✓*											
Wisconsin	✓	✓		✓		✓*						✓					
North Dakota	✓	✓*	✓*		✓*	✓*				✓*	✓*		✓*	✓*			
Missouri	✓	✓				✓	✓		✓								✓
City of Detroit	✓	✓	✓*	✓	✓*	✓*	✓			✓*			✓*				
Coleman-Stewart	✓	✓	✓*	✓	✓*												

✓ - variable present; ✓\* - variable present as a factor or rating; ● - formula is an accident prediction equation

Many state departments of transportation (DOTs) use a mixture of variables used based on variable values measured in the field and variables that incorporate factors as values based on lookup tables developed exclusively for quantifying HRGC risk. What is valuable to note is that the complete list of key variables identified by the Missouri expert panel (ref. 19) are present in the list of priority index variables discussed in the literature, either directly or as a factor derived from one of the variables listed in [Table 2-1](#).

The issue of variable use in priority indices was also approached by examining the variables used by state DOTs in their official (state) priority/hazard indices. As revealed from the summary of these results in [Table 2-2](#), consistency exists across DOTs concerning which variables are believed to be of the greatest importance in calculating the risk level at HRGCs. Again, the more common variables are frequently those identified by the Missouri expert panel (ref. 19).



**Table 2-2 State DOT Use of Variables in Priority Index Formulae**

<b>Priority Index Variable</b>	<b>Number of State DOTs Using Variable</b>
Trains per day	43
Existing protection	37
Accident records	23
Number of tracks	22
Highway vehicular speed	22
Condition or type of crossing	20
Number of traffic lanes	15
Sight distance	14
Daily distribution of vehicular or train volumes	14
Condition of approaches	6
Approach gradient	6
Type of train	5
Angle of crossing	5
School buses and/or HAZMAT carriers	5
Pedestrian hazard	1
Time crossing is blocked	1
Darkness	1

### **Crash Prediction Contribution of Priority Index Variables**

The motivation for including any combination of variables in a priority index formulation is to provide increasing accurate or representative means of identifying the risk or relative risk of crashes occurring at HRGCs. The literature review identified a number of previous studies that have attempted to document the contributions of various HRGC attributes/variables to calculations of crash risk. Most notably are those select studies that performed detailed statistical analyses to determine which variables are statistically significant within the analysis. [Table 2-3](#) summarizes the contribution of variables according to the reviewed literature.

**Table 2-3 Significance of Variables According to Statistical Analyses Reviewed**

<b>Variables</b>	<b>Austin &amp; Carson (2002)</b>	<b>Klaver (1993)</b>	<b>Sacomanno &amp; Lai (2005)</b>	<b>Sacomanno, Fu, Ren, Miranda (2003)</b>
<b><i>Traffic Characteristics</i></b>				
Number of Nightly Through Trains	Increase = Increased probability			
Total Number of Trains		Exposure (Trains*Vehicles)	Exposure (Trains*Vehicles)	Exposure (Trains*Vehicles) = most important factor
Max Timetable Speed	Increase = Increased probability			Significant for passive control & flashing light control crossings
Number of Main Tracks	Increase = Increased probability			Significant for gate control crossings
Number of Traffic Lanes	Increase = Increased probability			
AADT in Both Directions	Increase = Increased probability	Exposure (Trains*Vehicle)	Exposure (Trains*Vehicle)	Exposure (Trains*Vehicle) = most important factor
Road Speed			Significant	Significant for gate control crossings
<b><i>Roadway Characteristics</i></b>				
Highway Paved or Gravel	Paved = Increased Probability			
Track Angle			Significant	
Road Surface Width				Significant for flashing light control crossings
Sight Distance		Significant		

<i>Crossing Characteristics</i>				
Surface	Sectional and full wood plank = Increased probability			
Pavement Markings	Stop Lines = Increased probability			
Type of Protection	<ul style="list-style-type: none"> <li>• Stop signs = Increased probability</li> <li>• Gates = Reduced probability</li> <li>• Flashing lights = Increased probability</li> <li>• Traffic lights = Reduced probability</li> </ul>	Significant	Significant for passive control & flashing light control crossings	
Whistle Prohibition			Significant	

The first sets of variables are those associated with traffic characteristics. The four documents basically agree that the daily volume of road users and the number of trains are significant factors in analyzing risk at highway-rail grade crossings. However, Austin and Carson (2002) found that only the number of nightly through trains contributed significantly (ref 4). Two documents found that the maximum train timetable speed is significant, with one specifically finding significance for passive and flashing lights controlled crossings. Roadway speed was also found significant by two studies, however, only for gate control crossings according to Saccomanno et al. (ref 22). Austin and Carson (2002) found that as the number of main tracks and traffic lanes increased, the probability of a collision increased (ref 4). Saccomanno et al. (2003) found the number of tracks is significant only for gate control crossings (ref 22). None of the remaining three studies found the number of traffic lanes significant.

There is little correlation between the studies related to roadway characteristics. Only Klaver (1993) found sight distance to be a significant variable (ref 13). Finally, for crossing characteristics the type of protection at the crossing was considered significant by three of the studies. Austin and Carson (2002) and Saccomanno and Lai (2005) both found that protection levels of flashing lights or less contributed to risk, which indicates that improving grade crossing devices should include flashing lights and gates (refs. 4, 22).

### **Florida’s Crash Prediction Equation**

During the course of the literature review, information about the HRGC raking and improvement process in the State of Florida caught the research team’s attention due to recent research investigation and subsequent reformulation of that state’s priority index. Previous incarnations of Florida’s priority index were developed based on research conducted originally in 1973 and

re-examined in 1989 (ref. 18). The latest research, performed in 2004, added two new variables to the state’s HRGC crash prediction equation; number of tracks and number of roadway lanes. Both variables are proposed by the current research project’s team as potential variables for priority index revision in Texas. The current form of Florida’s crash prediction equation (adapted from (ref. 18) is shown in [Equation 2-1](#).

**Equation 2-1 Florida’s Crash Prediction Equation**

$$y = -8.242 + 0.601 * \text{LOG}_{10}((\text{Train} + 0.5) * \text{AADT}) + 0.012 * \text{HighwaySpeed} + 0.016 * \text{MaxTrainSpeed} + 1.137 * \text{NoTracks} + 1.648 * \text{NoLanes} - 0.887 * \text{Gates}$$

Where:

- y = crash prediction.
- Train = daily train volume.
- AADT = average daily traffic volume.
- HighwaySpeed = posted roadway speed limit at the crossing (mph).
- MaxTrainSpeed = maximum timetable train speed (mph).
- NoTracks = total number of tracks, including mainline and switching tracks.
- NoLanes = total number of through traffic lanes at the crossing.
- Gates = gate presence indicator (1 if gated; 0 if not).

An alternative formulation of the crash prediction equation generated for active crossings with flashers, as this index created a slightly higher correlation with crash history for crossings with flashers (but without gates) is shown in [Equation 2-2](#).

**Equation 2-2 Florida’s Crash Prediction Equation – Flashing Lights Only**

$$y = -7.959 + 0.554 * \text{LOG}_{10}((\text{Train} + 0.5) * \text{AADT}) + 0.015 * \text{HighwaySpeed} + 0.014 * \text{MaxTrainSpeed} + 1.032 * \text{NoTracks} + 1.54 * \text{NoLanes} - 0.801 * \text{Flash}$$

Florida grade crossing risk assessment procedures next call for the crash prediction results (y) be used to calculate the predicted number of crashes per year for each crossing, as seen in [Equation 2-3](#).

**Equation 2-3 Predicted Number of Crashes per Year**

$$P = 2e^y / (1 + e^y)$$

The predicted number of crashes is then adjusted based on recent crash history, as shown in [Equation 2-4](#).

#### Equation 2-4 Predicted Number of Crashes per Year Adjusted by Crash History

$$P^* = P \times \text{SQRT}(H/(P \times Y))$$

Where:

H = number of crashes last six years or since most recent warning device upgrade.

Y = number of years of crash history.

Finally, a *Safety Hazard Index* (SHI) is calculated as shown in [Equation 2-5](#).

#### Equation 2-5 Florida's Final Safety Hazard Index (SHI)

$$I = 90 \times (1 - \text{SQRT}(P^*/\text{MAXP})) - 5 \times \text{LOG}_{10}(B + 1) \times F$$

Where:

MAXP = maximum value for crash prediction (i.e., 1).

B = number of school buses.

F = 1 if active devices are present; 0 if passive devices are present.

Once all calculations are complete, Florida's equation produces an estimate of the relative crash risk at each HRGC in the state. If a crossing produces an SHI of 70 or greater, it can be expected to have a crash less often than once every 20 years and is not considered for improvement. If the SHI is less than 60, the crossing is expected to have a crash once every nine years or more frequently and is considered for improvement. Crossings with SHI values between 60 and 70 are considered marginal.

Florida's recent revision of its priority index (ref. 18) reveals that the inclusion of statistically relevant variables on a selective basis provides an improved means of both quantifying crash risk and providing a relative measure of the crash risk among the state's HRGCs.

## Synthesis of Spanish and French Practices

### Exposure

Spanish and French regulations, recommendations, and standards rely primarily on the exposure (the product of annual average daily traffic and the daily trains). Exposure is literally translated from both French and Spanish as "(traffic) circulation moment," respectively ("Moment/Momento de Circulation/Circulación") and is abbreviated as MC in some of this section's tables (refs. 16, 24). France's rules use exposure (MC) in addition to other factors such as train speed and sight distance (refs. 15, 24).

### Sight Distance

In Spain, there are two ways to define sight distance. Actual sight distance ("visibilidad real") is the distance between the intersection of the railroad and road medians, and the point where the approaching train starts to become visible from the mandatory stop sign on the road (ref. 16).

Actual sight distance of a grade crossing is the smallest of all “visibilidades reales” of all combinations of train and vehicular traffic directions.

Technical sight distance (“visibilidad técnica”) estimates the distance covered by a train at its maximum allowed speed during the time it takes for a vehicle to cross the entire at-grade crossing. It is calculated as:

**Equation 2-6**

$$Dt = 1.1Vm\sqrt{6.25 + n}$$

Where:

- Dt = Technical sight distance of the crossing (meters)
- Vm = Maximum train speed (km/h) at the crossing
- n = Number of rail lines to cross.

France bases some protection standards on the sight distance definitions described below. The formulas are for a vehicle placed between 3.5 and 5.0m from intersection between the highway and the nearest rail line. The two main formulas are depicted below (ref. 15):

**Equation 2-7**

$$R1 = 0.8F\sqrt{5.6 + n}$$

When “many” (actual number not defined in the regulations) vehicles longer than 14m clear the crossing at speeds less than 15km/h; or the crossing serves bovine herds larger than 8 animals, or ovine herds larger than 50 animals, the formula is:

**Equation 2-8**

$$R2 = F(3.4 + 0.7n)$$

Where:

- F = Maximum train speed (km/h) at the crossing
- n = Number of rail lines to cross.

### **Grade Separation**

In Spain, a Royal Decree requires either closing or grade-separating any crossing that has either exposure  $\geq 1500$ , or train speed  $\geq 160$  km/hr (approximately 100 mph) (ref. 25). This exposure threshold seemed too low to grade separate, although other references mention the same value. We asked our contacts in Spain, and they confirmed this low threshold, adding that they are due to concerns about the large number of long passenger trains prevalent all over Europe. Naturally, implementation of this decree is subject to available funds.

France does not have specific regulations about grade separation; decisions are made on a case-by-case basis. Grade separation should be considered when exposure is greater than 100,000 (Ref. 15).

### Spain's Minimum Protection for At-Grade Crossings

Table 2-4 shows the minimum types of protection a function of exposure (MC) and train speed (Ref. 31). The minimum possible passive signage includes a mandatory stop sign at least 5m before the crossing.

**Table 2-4 Spain's Standards for Minimum At-Grade Crossing Protection (Ref. 25)**

Class	Thresholds	On the Road / Motorists	On the Railroad / Trains
A	MC<1000	Crossbucks, stop sign, and no passing sign	Train horn 500m before the crossing
B	1000≤MC<1500	Class A plus two alternating flashing red lights and bells, both activated 30s before the train arrives	Class A plus signal indicating whether or not the flashing lights are functional
C	1000≤MC<1500 or Any MC if crossing is at a train station.	Gates, flashers, and bells. Lights and bells activated 45 sec before the train arrival, gates 60sec. Gates lower 6-8 sec after bells and lights and close completely in 10 sec.	Same as class B
D	1000≤MC<1500 and Train speed≤40km/hr	Class A plus a railroad agent to manually direct traffic.	Class A
E	Not specified	Classes B or C with protection activated by railroad agent in telephone contact with railroad control centers. Activation must occur 60 sec before train arrival.	Same as Class C

### France's Minimum Standards

France classifies at-grade crossings into four categories, and specifies minimum protection for each category based on exposure, AADT, sight distance, minimum speed to clear crossing, and other factors (Ref. 15); see Table 2-5 for a synthesis of these regulations.

**Table 2-5 France's Four Categories of At-Grade Crossings (Ref.15)**

Category	Characteristics	Minimum protection
1 <sup>st</sup>	<p>Vehicular traffic Public route Train speed ≤160km/h</p>	<p><i>Automated crossings</i> Automatic gates on the right side of the route in each direction Flashers on each direction Bells <i>Protected crossings</i> Vehicles: gates operated by rail agent Pedestrians: unprotected. If there is a pedestrian gate, pedestrians open it at their own risk.</p>
2 <sup>nd</sup>	<p>MC ≤3000 Train speed ≤140km/h Sight distance 600m</p> <hr/> <p>AADT &lt;10 Crossing clearable at 30km/h or less Sight distance 600m</p>	<p>Crossbucks on each direction</p> <hr/> <p>Crossbucks on each direction</p>
3 <sup>rd</sup>	<p>MC ≤5000 AADT ≤100 Sight distance 600m</p>	<p>Crossbucks and stop signs on each direction</p>
4 <sup>th</sup>	<p>Pedestrian only Private crossings, pedestrian or vehicular</p>	<p>Pedestrian responsibility Owner's responsibility</p>



## France's Guidelines for Improving Active Crossings

France treats the issue on a case-by-case basis. Ref. 24 is an official publication providing guidelines to improve crossings already actively protected by gates, flashers, and/or other active protection and still deemed potentially dangerous. Figure 2-1 depicts an active crossing selected for improvements that is discussed in Ref. 24. This reference recommends weighing two possibilities: closing the crossing, or addressing accident causes.



(A train may hide another)

**Figure 2-1 Example of Active Protection in France**

Source: ref. 24

Ref. 24 lists the five principal causes of accidents at active railroad crossings in France:

1. Automobiles approach crossing above posted speed limit;
2. Motorists drive around closed gates;
3. Poor visibility and legibility of the signs;
4. Queues from adjacent vehicular intersections spill back into the crossings; and
5. Crossing characteristics such sight distance, skid resistance, etc.

Improvement decisions are based on a survey of the principal causes of accidents at the crossing under consideration. Improvements consist of measures to address the cause(s). For example, install speed bumps for cause 1, provide law enforcement for cause 2, and so on.

Figure 2-2 shows the French schematic for full advance warning signs. The first sign on the highway (black rectangle) is a train-actuated variable message sign (VMS) indicating that the crossing is closed (“fermé”). Figure 2-3 depicts this VMS in detail.

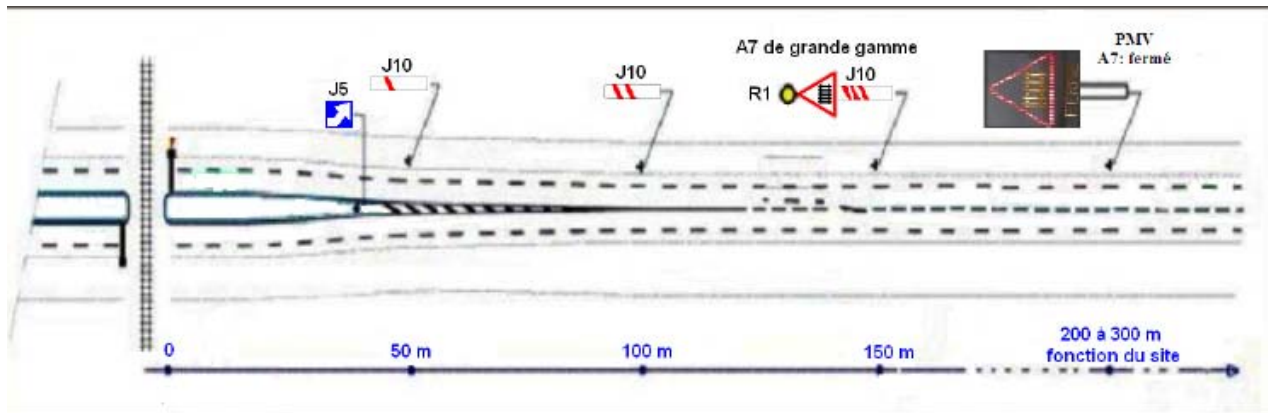


Figure 2-2 Fully Protected Crossing (Ref. 24)



Figure 2-3 VMS in Protected Crossing (Ref. 24)

Note: “fermé” means closed.

## Conclusions

In terms of number of persons exposed to risk, highway-rail collisions are more problematic in Europe than in the USA due to the large number of passenger trains prevalent in that continent. Spain’s and France’s rules, regulations and laws concerning the signalization and grade separation of highway-rail crossings are highly influenced by this fact, which is not a concern in Texas. Moreover, the researchers could not find systematic approaches or methodologies to prioritize crossings for improvements.

## Variables to Investigate as Part of Priority Index Statistical Analysis

A workshop combining the project researcher and Project Monitoring Committee (PMC) gathered on June 13, 2011, to discuss the variables the variables identified for potential inclusion into the priority index statistical analysis and the proposed initial warrant framework. Discussions during the meeting identified two additional variables to include in the investigation: angle of crossing and nearby roadway intersections. After the meeting, the research team sent a

survey to the PMC members to acquire direct input into the importance of each variable of interest. Table 2-6 contains the rankings each of the four respondents to the survey provided for the variables.

**Table 2-6 Rating of Different Variables for Upgrade from Passive to Flashers and Passive to Gates**

Variables		Respondents							
		1		2		3		4	
		Passive to flashers	Passive to gates	Passive to flashers	Passive to gates	Passive to flashers	Passive to gates	Passive to flashers	Passive to gates
Highway	AADT/traffic volume	5	5		4	3	4	1	3
	School buses	5	5		5	3	3	3	4
	Heavy vehicles	3	3		5	0	0	2	1
	Haz-mat route	1	1		5	3	3	3	4
	Highway lanes	4	4	4	1	2	2	3	4
	5-yr crashes > 0	4	4		2	0	0	1	1
	5-yr crashes > 1	4	4		3	1	1	3	3
	5-yr crashes > 2	4	4		5	3	3	5	5
	Urban/rural	5	5		3	0	0	3	3
	Nearby traffic signal	4	4		4	3	3	3	4
	Speed limit	4	4		1	2	2	4	4
	Pavement type	2	2		2	0	0	2	2
Railroad Crossings	Number of Tracks	5	5	4	4	2	2	2	4
	Number of Trains	5	5		5	3	4	3	4
	Approach angle	4	4		3	2	2	2	3
	Approach grade	2	2		4	0	0	1	1
	Sight distance	4	4	4	4	2	2	4	4
	Train speed	5	5		4	2	2	4	4
	Dips	1	1		4	0	0	1	1
	Humps	1	1		4	0	0	2	3
	No train horn allowed	0	0		1	2	2	3	4
Passenger Trains (added by respondent 2)				4					

Utilizing the current Texas priority index, other states' priority indices, literature review, and feedback from the PMC during discussions at the June 13, 2011, workshop, a total of 14 variables were identified to include in the in-depth analysis. Over the course of the second year low-profile crossings, also called humped crossings, was added to the analysis. Below is a listing of the variables by source:

TPI variables

1. Vehicular AADT.

2. Daily train volume.
3. Maximum train speed (through trains) or minimum train speed (switching trains).
4. Protection factor.
5. Daily school bus factor.
6. Number of crashes in last five years.

Other variables determined from literature review and other state indices

7. Number of tracks.
8. Posted highway speed.
9. Number of traffic lanes.
10. Daily distribution of train traffic.
11. Sight distance.
12. Condition/type of crossing.

Variables added during the June 13, 2011, workshop

13. Angle of crossing.
14. Nearby roadway intersection.

Variables added during the second year of investigation

15. Humped crossings.

The statistical analysis, discussed in [Chapter 4](#), analyzed TxDOT's TxRAIL database to identify which variable fields were associated with all of the above variables of interest. In almost all cases, each of the above items have more than one variable field within the database



## **CHAPTER 3 RESEARCH DATABASE**

### **Overview**

The first task of this project consisted of the literature review presented in the previous chapter and the development of a research database. The objectives of a research database were to review the data and understand its scope; to prepare data sets for research purposes; to obtain missing information when possible; and to submit new data as well as the results of the data review for TxDOT evaluation and utilization in the new Texas Rail Information Management System (TRIMS), being developed at the same time as this project.

The research database contains data for 24,477 at-grade crossings, obtained after merging information and records from the following sources and databases:

#### *1. Rail Data Bases*

- Texas Railroad Crossing Inventory (TRACI), obtained from TxDOT's Rail Division.
- Texas Railroad Database (TxRAIL), also obtained from TxDOT's Rail Division.
- Federal Railroad Administration (FRA) online databases, obtained from the website <http://safetydata.fra.dot.gov/OfficeofSafety/Default.aspx>.

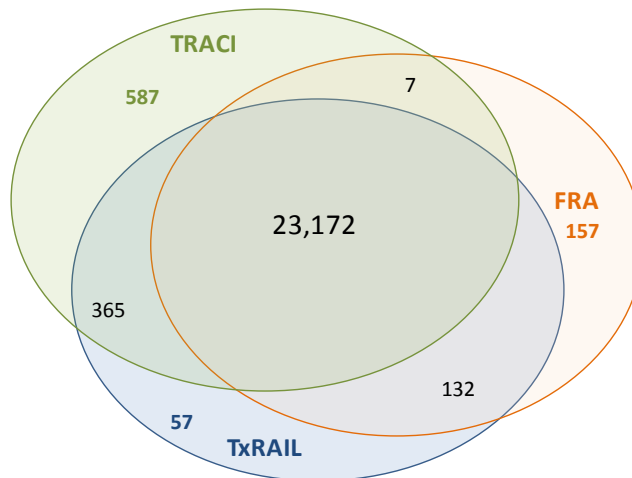
#### *2. Other Transportation Databases*

- Road–Highway Inventory Network (RHiNo).
- Pavement Management Information System (PMIS).
- Files containing annual average daily traffic data (AADT), obtained from TxDOT's Transportation Planning and Programming (TP&P).

Figure 3-1 shows the number of crossings appearing in each database; 23,172 crossings (94.7 percent) appear in all three databases. This task was developed in the first year of this project, so Figure 3-1 displays 2010 data.

### **Data Updates**

Given the importance of annual average daily traffic (AADT) data for this project, TTI researchers obtained the most recent AADT from TxDOT Transportation Planning and Programming (TP&P) data, which included 7,061 crossings. TP&P data were further merged with the other databases (TRACI, TxRAIL, RHiNo and FRA) to create Access table “AADT” in the research database. This table has the AADT data and AADT year for each crossing, from each source.



**Figure 3-1 Number of Crossings in Each Rail Database**

RHiNo is not a rail database and therefore it does not have crossing identification numbers. However, both TRACI and RHiNo databases are geo-referenced and could be overlaid in ArcGIS. AADT data from RHiNo were assigned to TRACI's crossings with a proximity algorithm. The algorithm was tested to ensure that no AADT measured in freeway main lanes would inadvertently be assigned to crossings located at adjacent frontage or service roads. TxDOT's PMIS database was used in analogous manner. Since RhiNO and PMIS come from the same source, PMIS added AADT data for only four more crossings.

The researchers were able to update data for 3,922 crossings in TxRAIL's GxForm table. These crossings either did not have AADT information or had old data. The updated AADT data were delivered to TxDOT during the project in electronic format.

### **Research Database Structure**

The research database is an Access database containing the following tables that can be joined by crossing identification number: AADT—Accidents—Devices—Features—Installation Dates—Location—School Buses—Sight Distance—Speeds—Train Traffic—2010prioritylist. The names of these variables start with the name of the database they came from followed by an underscore. For example, the variable representing daily school buses, which is found in all three rail databases, appears three times in the research database, as "TRACI\_SchoolBuses," "FRA\_SCHLBUS," and "TxRAIL\_SchoolBus."

TxRAIL data were extracted from the following tables: T-CrossingPROJECT, tblCONTROLS, and GxForm. All variables coming from T-CrossingPROJECT, tblCONTROLS and GxForm have prefixes TCrosPro-TxRail, TblCon-TxRail and Gx-TxRail, indicating which source database and which table in the database the variables came from. All variables with prefix TxRAIL come from GxForm table. During the project development, additional variables were investigated. The research database kept the original TxRAIL hierarchical structure and the crossing ID as the main parent variable, so it was simple to merge additional variables into the research database as needed.

## Priority List

The priority list is an additional Access table in TxRAIL, called *T-AnnualStateList-<YYYY>* that contains the original Texas Priority Index (TPI) discussed in [Chapter 1](#). TxRAIL's priority list is updated yearly. The TPI values are calculated with data extracted from the following other TxRAIL tables: Districts-TX, GxForm, PTable-<dates>-FRA (crash data), and Q-CrossingPROJECT-MostCurrent (most recent completed projects).

Access Table titled "PriorityTable-YYYY-Spreadsheet" is a subset of *T-AnnualStateList-YYYY* with the following conditions: public, open, and at-grade crossings that have AADT information. The researchers noted two inconsistencies between PriorityTable-2010-Spreadsheet and T-AnnualStateList-2010:

- Crossing 273116E is present in TxRAIL's GxForm but not in T-AnnualStateList.
- Crossings 435466N, 761455U, 416521T, 675257A, and 765950N are present in T-AnnualStateList 2010 but not in GxForm.

The researchers coded the TPI formula with 2010 data and again with 2011 data, replicating the calculations coded in PriorityTable-2010-Spreadsheet and PriorityTable-2011-Spreadsheet. There were only two mismatches between newly coded TPI and gxPI in PriorityTable-2010-Spreadsheet table (which has a total of 9,588 crossings). The mismatched values are for crossings 014786J and 597096S. In 2011, however, the researchers found 3,322 mismatches (34.4 percent of the 9,671 crossings in PriorityTable-2011-Spreadsheet) and could not find a cause for this. Since one likely explanation for the 2011 TPI mismatches is data updating done after the TPI calculations, the newly calculated 2011 values were used for research purposes.

## Comparisons among Data Sources

Two crossings in TRACI do not have crossing identification numbers (IDs). One of them has a "field crossing number" instead (762764W), which is also present in FRA databases. The research database lists 762764W as the crossing ID for this crossing. Crossing 765680E is present in TP&P data but not in TxRail, TRACI or FRA. The following crossings appeared twice in the TP&P data with different AADT values: 024316D-274815H-416417Y-416597Y-676163C-790095N-796261Y-848987E. The highest AADT was selected.

TxRAIL's GxFORM table (23,726 crossings) and TP&P data (7,061 crossings) were compared, resulting in 507 AADT mismatches for the same AADT year. There are four mismatches for the variable AADT between RHiNo and TxRAIL's GxFORM table.

Several additional comparisons were performed among the three most important TxRAIL tables: GxFORM, T\_AnnualStateList\_2010, and tblCONTROLS. These comparisons are depicted in [Appendix 1](#).

Inconsistencies among sources were analyzed and discussed with the Project Monitoring Committee (PMC) during a December 2010 meeting. The majority were resolved by using the most recent data (when last update information was available). An important decision was to use TxRAIL data for all unresolved inconsistencies, since it contains the most up-to-date rail



crossing information available at TxDOT. Missing values for the highway speed limit variables SpeedLimit and SpeedLimit2 (speed limits at each crossing approach) were assigned the following default values when absent: 30 mph in urban areas and 55 mph in rural areas.

## **Conclusion**

The research database contains the most comprehensive and updated data records that the researchers could find and as such was used during the basic investigations. The results presented in the subsequent chapters, however, are presented for the most recent data (TxRAIL 2011).

A significant issue that could not be resolved during the development of this project is the sight distance obstruction update (variables StopObs1 and 2). The vast majority of the values in TxRAIL 2011 were still outdated, and results including this variable could not be calculated.

## CHAPTER 4 TEXAS PRIORITY INDEX STATISTICAL ANALYSIS AND REVISED FORMULATION

The objective of this analysis is to develop a crash prediction model that can estimate the expected number of crashes at HRGC based on the characteristics of crossings and the crash history and to revise the current Texas Priority Index (TPI) using the results. The crossings considered in this analysis are all open public at-grade crossings.

### Data

The data for 9,741 open public at-grade crossings were extracted from TxRAIL 2011 for the analysis. Because railroad crashes are very rare and the crash count at each crossing is mostly zero if only yearly crash counts are considered, researchers compiled the aggregated crash data over multiple years (5 years and 10 years) at each crossing. Crashes for 2001–2010 and for 2006–2010 were considered for selection of relevant variables and calibration of model coefficients, respectively, which will be described in detail in the next section. Crashes from 2011 were also extracted and set aside for the validation of the revised TPI. The steps for extracting the variables describing the characteristics of crossings and the corresponding crash data are described in detail below.

### Steps for Creating TxRAIL 2011 Base Data Table

#### Step 1: Variable Capture

- Created Access database with the following tables pulled from TxRAIL
  - o GxForm
  - o tblCONTROLS
- Variables captured from GxForm and tblCONTROL are listed in [Table 4-1](#).

**Table 4-1 Variables Captured from GxForm and tblCONTROL**

o CrossingNumber	o ActualSD2
o PosCrossing	o CalcApp1SD
o TypeCrossing	o CalcApp2SD
o Reason	o DTFeet1
o AADT	o DTFeet2
o PAADT	o MaxSpeed
o HwyPaved	o MinSpeed
o UrbanRural	o NearbyInt1 (tblCONTROL)
o CrossAngle	o NearbyInt2 (tblCONTROL)
o HwyNear	o NearSignalized1 (tblCONTROL)
o TrafLane	o NearSignalized2 (tblCONTROL)
o MainTrack	o SpeedLimit
o OtherTrack	o SpeedLimit2
o DaySwt	o DipHump
o DayThru	o Gouge
o NightSwt	o HumpSign1 (tblCONTROL)

<ul style="list-style-type: none"> <li>○ NightThru</li> <li>○ TotalTrn</li> <li>○ TotalSwt</li> <li>○ SchoolBus</li> <li>○ ActualSD1</li> </ul>	<ul style="list-style-type: none"> <li>○ HumpSign2 (tblCONTROL)</li> <li>○ StopObs1</li> <li>○ StopObs2</li> </ul>
---	--

- Variables captured from GxForm and tblCONTROL for Step 2: Variable Creation include:
  - Gates
  - FlashMast
  - Cantilevers
- Statistics
  - 26,188 total crossings

### Step 2: Variable Creation

- Variables to create:
  - NearbyInt
  - NearSignalized
  - Higher\_SPD\_Lmt
  - P-f
  - G\_or\_F
  - SVF
  - A5\_01-05
  - A5\_6-10
  - Crash2011
  - AADTF
  - TotalTrack
- Step pre-2a:
  - SpeedLimit\_val
    - Blank = 0
  - SpeedLimit2\_val
    - Blank = 0
  - NearbyInt1\_val
    - 1, 2 = 1,2
    - Blank, 0 = 0
  - NearbyInt2\_val
    - 1, 2 = 1, 2
    - Blank, 0, 4 = 0
  - NearbySignalized1\_val
    - 1, 2 = 1, 2
    - Blank, 0, 9 = 0
  - NearbySignalized2\_val
    - 1, 2 = 1, 2
    - Blank, 0, 9 = 0

- Step 2a:
  - o Gate
    - If Gates is greater than zero, then Gate = 1, else zero
  - o Flashers
    - If FlashMast or Cantilivers is greater than zero, then Flashers = 1, else zero
  - o SpeedLmt1
    - If If SpeedLimit\_val is not equal to zero, then SpeedLmt1 = SpeedLimit\_val, else
      - If UrbanRural = “1” (Urban), then SpeedLmt1 = 30
      - If UrbanRural = “2” (Rural), then SpeedLmt1 = 55
    - If no speed value and no UrbanRural value, then blank
  - o SpeedLmt2
    - If If SpeedLimit2\_val is not equal to zero, then SpeedLmt2 = SpeedLimit2\_val,
      - If UrbanRural = “1” (Urban), then SpeedLmt2 = 30
      - If UrbanRural = “2” (Rural), then SpeedLmt2 = 55
    - If no speed value and no UrbanRural value, then blank
  - o NearbyInt\_chk
    - Blank if both variables are zeros
  - o NearSignalized\_chk
    - Blank if both variables are zeros
  - o AADTF
    - If PAADT is greater than zero, then AADTF = PAADT, else AADTF = AADT
- Step 2b:
  - o NearbyInt
    - If NearbyInt1 or NearbyInt2 equal “1” (Yes), then “1” (Yes), else “2” (No)
    - If both blank, then blank
  - o NearSignalized
    - 1 (Yes) if NearbySignalized1 or NearbySignalized2 equal 1 (Yes), else “2” (No)
    - If both blank, then blank
  - o Higher\_SPD\_Lmt
    - Choose higher value of SpeedLimit1 and SpeedLimit2
    - Blank if both blank
  - o P-f
    - If Gate is greater than zero, then P-f = “G”
    - If Gate is equal to zero and Flashers is greater than zero, then P-f = “F”

- If Gate and Flashers equal zero, then P-f = “X”
  - G\_or\_F
    - If Gate or Flashers is greater than zero, then G\_or\_F = 1 (Yes - Active), else 2 (No - Passive)
  - SVF
    - If SchoolBus = zero, then 1
    - If SchoolBus = 1-3, then 1.2
    - If SchoolBus = 4-10, then 1.6
    - If SchoolBus is greater than or equal to 11, then 2
  - TotalTrack
    - TotalTrack = MainTrack + OtherTrack
- Step pre-2c: Crashes
  - From the FRACrashes TxRAIL data table
    - A5\_01-05
    - A5\_06-10
  - From the FRA Website
    - Crash2011
- Step 2c: Crash Variables
  - Replace missing with zeros

### Step 3: Variable Capture and Creation Combined

- Combined the captured and created variables

### Step 4: Variable Correction

- Zeros to blanks
  - AADTF
  - HwyPaved
  - UrbanRural
  - CrossAngle
  - HwyNear
  - Traflane
  - TotalTrack

### Step 5: Final Table for Calibration of Model Coefficient

- Filtered for:
  - PosCrossing = 1 (At grade)
  - TypeCrossing = 3 (Public vehicle)
  - Reason = 1 (Open crossing)
- Added gxPI from T-AnnualStateList-2011 TxRAIL data table
- Resulted in 9,741 crossings

The distribution plots and summary statistics of the variables in Table 4-1 were generated and reviewed first. An initial review revealed that not all of the variables in Table 4-1 were relevant for crash prediction. The variables that have more than 50 percent of missing values or have the same value for almost all crossings were removed from further consideration. For example, among the humped crossing-related variables, the variable Gouge has 99 percent missing values and HumpSign1 and HumpSign2 have the same value for 99 percent of crossings (2 for 99 percent of crossings and 1 for less than 1 percent of crossings) and were removed consequently. DipHump was the only reasonably-populated humped crossing-related variable. The variables representing the different roadway approaches to the crossings (e.g., NearbyInt1 and NearbyInt2) have been consolidated into one variable having ‘Yes’ if either of the variables has a ‘Yes’ value. NearbyInt1 and NearbyInt2 have been consolidated into NearbyInt, and NearSignalized1 and NearSignalized2 have been consolidated into NearSignalized as noted in Step 2. SpeedLimt and SpeedLimt2 have also been consolidated into a new variable ‘Higher\_SPD\_Lmt’ by choosing a higher approach speed limit between those two variables.

Another problem noticed during the initial review of the original variables in Table 4-1 was the presence of many zeros (in addition to missing values) in several variables. While zeros may make a physical sense for some of the variables, in some cases zeros did not seem to be valid observations and seemed to have been used to represent ‘missing values.’ Those zeros intended to represent missing values were replaced by blanks in Step 4. Table 4-2 contains the percentage of missing data for the 9,741 crossings retained in the final table after such correction has been made.

**Table 4-2 Percentage of Missing Data for the Variables in the Final Table for 9,741 Crossings**

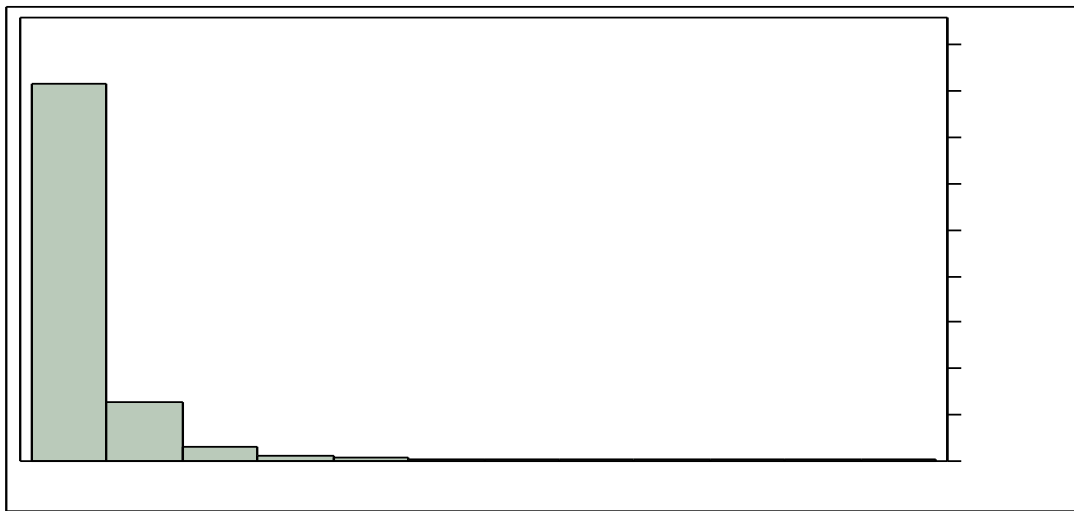
<b>Variable</b>	<b>Number of missing values</b>	<b>Percentage missing</b>
AADT	164	1.7%
PAADT	2	0.0%
AADTF	164	1.7%
HwyPaved	474	4.9%
UrbanRural	168	1.7%
CrossAngle	281	2.9%
HwyNear	29	0.3%
TrafLane	308	3.2%
MainTrack	315	3.2%
OtherTrack	315	3.2%
TotalTrack	315	3.2%
DaySwt	0	0.0%
DayThru	0	0.0%

NightSwt	0	0.0%
NightThru	0	0.0%
TotalTrn	0	0.0%
TotalSwt	0	0.0%
SchoolBus	0	0.0%
ActualSD1	0	0.0%
ActualSD2	0	0.0%
CalcApp1SD	46	0.5%
CalcApp2SD	46	0.5%
DTFeet1	45	0.5%
DTFeet2	45	0.5%
MaxSpeed	0	0.0%
MinSpeed	0	0.0%
NearbyInt1	136	1.4%
NearbyInt2	87	0.9%
NearSignalized1	2817	28.9%
NearSignalized2	2899	29.8%
SpeedLimit	0	0.0%
SpeedLmt1	161	1.7%
SpeedLimit2	0	0.0%
SpeedLmt2	161	1.7%
DipHump	2629	27.0%
P_f	0	0.0%
P_f_5yrs	0	0.0%
P_f_10yrs	0	0.0%
G_or_F	0	0.0%
SVF	0	0.0%
NearbyInt	87	0.9%
NearSignalized	2770	28.4%
Higher_SPD_Lmt	161	1.7%

## Crash Analysis and Prediction Models

Researchers analyzed both the 10 year aggregated crash data for 2001–2010 and the 5 year aggregated crash data for 2006–2010 for development of crash prediction models to cope with insufficient crash data. Recall that the rail road crashes are rare events and most crossings (e.g., 98 percent) have zero yearly crash count. The following two figures show the distribution of 10 year aggregated crashes per crossing and that of 5 year aggregated crashes per crossing, respectively. It can be observed from [Figure 4-1](#) that about 83 percent of crossings have zero crash, 13 percent have one crash, 3 percent have two crashes, and the remaining 1 percent of crossings have at least 3 crashes during the 10 year period. [Figure 4-2](#) shows that, for the 5 year period, about 92 percent of crossings have zero crash, 7 percent have one crash, 1 percent have two crashes, and less than 0.4 percent of crossings have at least 3 crashes.

**10 year crash count**

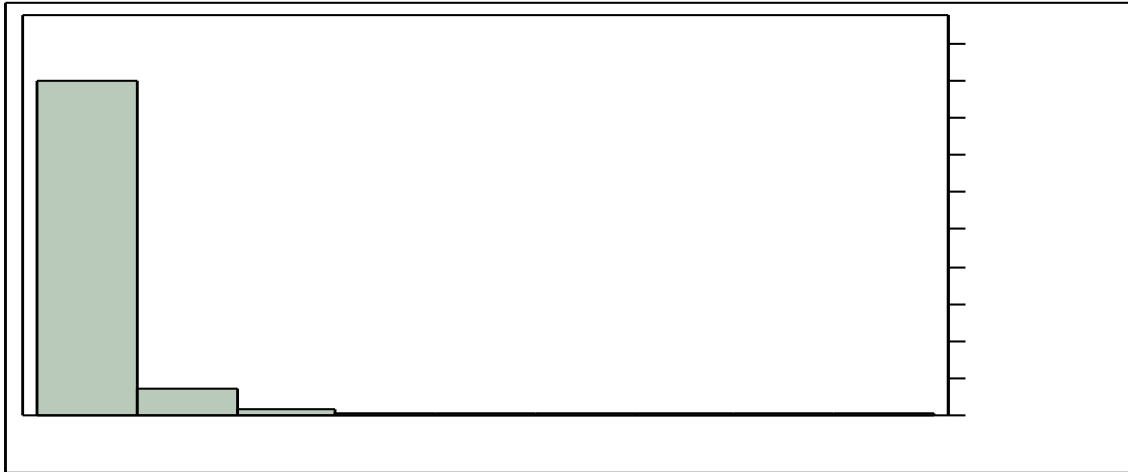


Frequencies		
Level	Count	Prob
0	8103	0.83184
1	1232	0.12648
2	262	0.02690
3	77	0.00790
4	34	0.00349
5	13	0.00133
6	7	0.00072
7	3	0.00031
8	5	0.00051
9	1	0.00010
10	3	0.00031
11	1	0.00010
Total	9741	1.00000

**Figure 4-1 Distribution for 10-year Aggregated Accident Frequency**



### 5 year crash count



Frequencies		
Level	Count	Prob
0	8916	0.91531
1	675	0.06929
2	108	0.01109
3	27	0.00277
4	8	0.00082
5	2	0.00021
6	1	0.00010
7	1	0.00010
8	3	0.00031
Total	9741	1.00000
Total	9741	1.00000

**Figure 4-2 Distribution for 5-year Aggregated Accident Frequency**

Researchers explored crash prediction equations using various negative binomial regression models with different predictors. Note that negative binomial regression fits the regression equation to crash frequency to derive the regression equation for the predicted (expected) number of crashes for each crossing. The general form of the expected number of crashes in a negative binomial regression model is shown in [Equation 4-1](#).

#### **Equation 4-1 Negative Binomial Regression Model General Form**

$$\mu_i = \exp(\beta_0 + \beta_1 X_{1i} + \beta_2 X_{2i} + \dots + \beta_k X_{ki})$$

where  $\mu_i$  is the expected (or predicted) number of crashes at crossing  $i$ ,  $X_{1i}, \dots, X_{ki}$  are the covariates/predictors corresponding to the characteristics of crossing  $i$ , and  $\beta_0, \beta_1, \beta_2, \dots, \beta_k$  are the regression coefficients. Initially, crashes from 2001–2010 (10 year aggregated data) were used for exploration of various models and selection of relevant variables for crash prediction.

#### **Negative Binomial Regression Analysis for 10 Year Aggregated Crashes**

Ten year aggregated crash frequency was first used as a dependent variable for negative binomial regressions. To prevent important variables from not being selected as statistically significant

variables only because of insufficient crash data, the 10 year aggregated crash data (rather than the 5 year aggregated crash data) were used to explore various negative binomial regression models with different predictors. Variables in Table 4-2 were considered as candidate predictor variables. Because of high correlations in some of the variables in Table 4-2 (e.g., correlation between DaySwt and NightSwt is 0.8258, correlation between DayThru and NightThru is 0.8279, correlation between DayThru and TotalTrn is 0.8224, correlation between CalcApp1SD and CalcApp2SD is 0.9703, and correlation between DTFeet1 and DTFeet2 is 0.9999), not all variables could be included in the models simultaneously. Models were explored using various subsets of variables in Table 4-2. Different transformations of the exposure variables were also considered (e.g.,  $\log(\text{AADTF})$ ,  $\log_{10}(\text{AADTF})$ ,  $\log_{10}(\text{TotalTrn})$ ,  $\log_{10}(\text{TotalTrn}+0.5)$ ,  $\log_{10}[(\text{TotalTrn}+0.5)\times\text{AADTF}]$  and so on).

After exploring various negative binomial regression model forms with different predictors, the model including P\_f, HwyPaved, UrbanRural, CrossAngle, TrafLane, TotalTrack, SchoolBus, ActualSD1, ActualSD2, MaxSpeed, MinSpeed,  $\log_{10}(\text{TotalTrn}+0.5)$ ,  $\log_{10}(\text{TotalSwt}+0.5)$ ,  $\log_{10}(\text{AADTF})$ , NearbyInt, and Higher\_SPD\_Lmt, and DipHump as predictors and  $\log(10)$  as an offset variable (used to derive the predicted number of crashes per year rather than per 10 years) was selected as an appropriate initial model for the data. Because of missing values in some of the predictor variables in the model (e.g., the value of DipHump was missing for 27 percent of crossings), the number of crossings that could actually be used for model fitting was reduced to 6,807. The estimated regression coefficients for the data from 6,807 crossings with non-missing predictor variables along with the corresponding p-values are presented in Table 4-3. The variables that are statistically significant (at  $\alpha=0.05$ ) are P\_f, HwyPaved, UrbanRural, TrafLane, ActualSD1, MaxSpeed, MinSpeed,  $\log_{10}(\text{TotalTrn}+0.5)$ ,  $\log_{10}(\text{AADTF})$ , NearbyInt, and Higher\_SPD\_Lmt. The variable TotalTrack was at the borderline statistical significance (P-value = 0.0558).

**Table 4-3 Estimates of Regression Coefficients of Negative Binomial Regression Models Applied to 10 year Aggregated Crash Frequency Data from 6,807 Crossings with Non-Missing Predictor Variables**

<b>Variable</b>	<b>Coefficient</b>	<b>P-value</b>
Intercept	<b>-6.5352</b>	<b>&lt;0.0001</b>
P_f=F	<b>0.6150</b>	<b>&lt;0.0001</b>
P_f=G	0.1401	0.1685
P_f=X	0.0000	.
HwyPaved (1=Paved; 2=Not Paved)	<b>0.3196</b>	<b>0.0015</b>
UrbanRural (1=Urban; 2=Rural)	<b>-0.4169</b>	<b>&lt;0.0001</b>
CrossAngle	0.0103	0.8996
TrafLane	<b>0.0748</b>	<b>0.0161</b>

TotalTrack	0.0705	0.0558
SchoolBus	0.0015	0.6862
ActualSD1	<b>0.0016</b>	<b>0.0259</b>
ActualSD2	0.0008	0.2778
MaxSpeed	<b>0.0125</b>	<b>&lt;0.0001</b>
MinSpeed	<b>0.0072</b>	<b>0.0010</b>
Log10(TotalTrn+0.5)	<b>0.8186</b>	<b>&lt;0.0001</b>
Log10(TotalSw+0.5)	0.0199	0.7918
Log10(AADTF)	<b>0.3690</b>	<b>&lt;0.0001</b>
NearbyInt (1=Present; 2=Not Present)	<b>-0.1802</b>	<b>0.0059</b>
Higher_SPD_Lmt	<b>0.0157</b>	<b>&lt;0.0001</b>
DipHump	-0.1145	0.0797

Note: Statistically significant effects at  $\alpha=0.05$  are denoted in bold.

The negative binomial regression model was re-fitted with including statistically significant variables (at  $\alpha=0.05$ ) in Table 4-3 and TotalTrack. The results are presented in Table 4-4. After the variable DipHump was excluded from the model (because it was statistical insignificant and has too many missing values), the number of crossings with non-missing predictor variables was increased to 9,108.

**Table 4-4 Estimates of Coefficients of Negative Binomial Regression Models with Significant Variables Applied to 10 year Aggregated Crash Frequency Data from 9,108 Crossings**

Variable	Coefficient	P-value
Intercept	<b>-6.6468</b>	<b>&lt;0.0001</b>
P_f=F	<b>0.5445</b>	<b>&lt;0.0001</b>
P_f=G	0.0801	0.1685
P_f=X	0.0000	.
HwyPaved (1=Paved; 2=Not Paved)	<b>0.2786</b>	<b>0.0015</b>
UrbanRural (1=Urban; 2=Rural)	<b>-0.3809</b>	<b>&lt;0.0001</b>
TrafLane	<b>0.0670</b>	<b>0.0188</b>
TotalTrack	<b>0.0692</b>	<b>0.0288</b>
ActualSD1	<b>0.0023</b>	<b>&lt;0.0001</b>

MaxSpeed	<b>0.0126</b>	<b>&lt;0.0001</b>
MinSpeed	<b>0.0072</b>	<b>0.0001</b>
Log10(TotalTrn+0.5)	<b>0.8478</b>	<b>&lt;0.0001</b>
Log10(AADTF)	<b>0.4114</b>	<b>&lt;0.0001</b>
NearbyInt (1=Present; 2=Not Present)	<b>-0.1469</b>	<b>0.0081</b>
Higher_SPD_Lmt	<b>0.0100</b>	<b>0.0002</b>

Note: Statistically significant effects at  $\alpha=0.05$  are denoted in bold.

### Negative Binomial Regression Analysis for 5 Year Aggregated Crashes

A caveat for the TxRAIL database is that all the inventory characteristics in the database come from the most current inventory data, i.e., the values for the crossing characteristic variables are only for the most recent year. As a result, changes in the characteristics of a crossing (including AADTF and number of trains such as TotalTrn) over years are not reflected in the TxRAIL data, which is a limitation of the database. This could potentially be a problem in the analysis with crashes for multiple years (especially for the extended period of time such as 10 years) if the changes over time for those variables are significant. One of the underlying assumptions in this cross-sectional crash analysis is that there have not been significant changes in crossing characteristic variables over time at each crossing. Because the 5 year data are expected to experience fewer changes in the characteristics of crossings (if there are any) compared to the 10 year data, researchers re-calibrated the model coefficients in [Table 4-4](#) using the more recent 5 year data (2006–2010).

The results of fitting the model with P\_f, HwyPaved, UrbanRural, TrafLane, TotalTrack, ActualSD1, MaxSpeed, MinSpeed, log10(TotalTrn+0.5), log10(AADTF), NearbyInt, and Higher\_SPD\_Lmt as predictors and log(5) as an offset variable (used to derive the predicted number of crashes per year rather than per 5 years) are presented in [Table 4-5](#). It can be seen that estimated coefficients based on the 5 year data are not significantly different from those based on the 10 year data. Although some of the variables (TrafLane and TotalTrack) in [Table 4-5](#) became statistically insignificant (at  $\alpha=0.05$ ) due to less crash data, the coefficients are close to those in [Table 4-4](#) and it did not seem to be a problem to retain those variables in the final crash prediction equation. As the sample size increases (i.e., the more crash data are obtained), those variables are expected to be statistically significant.

**Table 4-5 Estimates of Coefficients of Negative Binomial Regression Models with Significant Variables Applied to 5 year Aggregated Crash Frequency Data from 9,108 Crossings**

Variable	Coefficient	P-value
Intercept	<b>-6.9240</b>	<b>&lt;0.0001</b>
P_f=F	<b>0.5061</b>	<b>0.0035</b>
P_f=G	-0.2006	0.1026
P_f=X	0.0000	.
HwyPaved (1=Paved; 2=Not Paved)	<b>0.2587</b>	<b>0.0348</b>
UrbanRural (1=Urban; 2=Rural)	<b>-0.3722</b>	<b>0.0003</b>
TrafLane	0.0706	0.0815
TotalTrack	0.0656	0.1459
ActualSD1	<b>0.0022</b>	<b>0.0068</b>
MaxSpeed	<b>0.0143</b>	<b>&lt;0.0001</b>
MinSpeed	<b>0.0126</b>	<b>&lt;0.0001</b>
Log10(TotalTrn+0.5)	<b>1.0024</b>	<b>&lt;0.0001</b>
Log10(AADTF)	<b>0.4653</b>	<b>&lt;0.0001</b>
NearbyInt (1=Present; 2=Not Present)	<b>-0.2160</b>	<b>0.0063</b>
Higher_SPD_Lmt	<b>0.0092</b>	<b>0.0139</b>

Note: Statistically significant effects at  $\alpha=0.05$  are denoted in bold.

Using the coefficients in Table 4-5, the final crash prediction equation is shown in Equation 4-1.

**Equation 4-2 Final Crash Prediction Equation**

$$\hat{\mu} = \exp[-6.9240 + P\_f\_indicator\_T + 0.2587 \times HwyPaved - 0.3722 \times UrbanRural + 0.0706 \times TrafLane + 0.0656 \times TotalTrack + 0.0022 \times ActualSD1 + 0.0143 \times MaxSpeed + 0.0126 \times MinSpeed + 1.0024 \times \text{Log}_{10}(TotalTrn + 0.5) + 0.4653 \times \text{Log}_{10}(AADT) - 0.2160 \times NearbyInt + 0.0092 \times Higher\_SPD\_Lmt] \quad (1)$$

where

$\hat{\mu}$  = predicted number of crashes per year at a crossing.

$$P\_f\_indicator\_T = \begin{cases} 0.5061 & \text{if } P\_f = F \\ -0.2006 & \text{if } P\_f = G \\ 0 & \text{if } P\_f = X \end{cases}$$

HwyPaved=1 if paved; 2 if not

UrbanRural=1 if Urban; 2 if Rural

TrafLane=Number of roadway lanes

TotalTrack=Number of Main Tracks+Number of Other Tracks

ActualSD1=Actual stopping distance, approach 1

MaxSpeed=Maximum typical train speeds

MinSpeed=Minimum typical speeds for switching

TotalTrn=Total daily trains

AADTF==PAADT (when it exists) or AADT (when PAADT does not exist)

NearbyInt=1 if nearby intersection is present in either approach; 2 if not

Higher\_SPD\_Lmt=Higher roadway speed limit between approach 1 and approach 2

## Revised Texas Priority Index

The existing TPI ( $TPI_{old}$ ) based on six variables (see [Chapter 1](#)) with mostly equal coefficients (1 for all but one, the number of crashes in the last five years) does not appropriately reflect the crash risk at each crossing. Although different variables may differently affect crash risk at a crossing (to a different extent/degree), it has not been accounted for in  $TPI_{old}$ .

A physically meaningful priority index should account for various effects of different variables on crashes and appropriately reflect the crash risk at each crossing. An improved index that is based on a crash prediction model ensuring that all important variables affecting crash risks are appropriately modeled with calibrated coefficients based on the actual crash data is desirable.

The prediction equation in [Equation 4-3](#) can be used as a basis for the revised Texas Priority Index. Recall that  $\hat{\mu}$  represents the expected (or predicted) number of crashes per year at a crossing. The revised TPI can be formulated by adjusting  $\hat{\mu}$  for crash history at that crossing to account for extraneous factors, while impacting each individual crossing, not included in the prediction equation. The most recent 5 year crash history can be used as an adjustment factor. Researchers recommend the following form as a revised TPI:

### Equation 4-3 Revised TPI

$$TPI_{revised} = 1000 \times \hat{\mu} \times (A_5 + 0.1)$$

where

$$\hat{\mu} = \exp[-6.9240 + P\_f\_indicator\_T + 0.2587 \times HwyPaved - 0.3722 \times UrbanRural + 0.0706 \times TrafLane + 0.0656 \times TotalTrack + 0.0022 \times ActualSD1 + 0.0143 \times MaxSpeed + 0.0126 \times MinSpeed + 1.0024 \times \log_{10}(TotalTrn + 0.5) + 0.4653 \times \log_{10}(AADT) - 0.2160 \times NearbyInt + 0.0092 \times Higher\_SPD\_Lmt]$$

$A_5$  = number of crashes in last five years at a crossing.

To prevent multiplying  $\hat{\mu}$  with 0 for the crossings with no crash for the past 5 years and consequently making the ranks for those crossings all the same, a small positive number (0.1) was added to  $A_5$  before multiplication.

The following steps can be used to derive the calculate Texas Priority Index ( $TPI_{revised}$ ).

#### Step 1: MuHat Calculation

Obtain the predicted number of crashes per year for each crossing,  $\hat{\mu}$ , which is required for the  $TPI_{revised}$  calculation (see Equation 4-4).

#### **Equation 4-4 MuHat Calculation**

$$\hat{\mu} = \exp[-6.9240 + P\_f\_indicator\_T + 0.2587 \times HwyPaved - 0.3722 \times UrbanRural + 0.0706 \times TrafLane + 0.0656 \times TotalTrack + 0.0022 \times ActualSD1 + 0.0143 \times MaxSpeed + 0.0126 \times MinSpeed + 1.0024 \times \log_{10}(TotalTrn + 0.5) + 0.4653 \times \log_{10}(AADT) - 0.2160 \times NearbyInt + 0.0092 \times Higher\_SPD\_Lmt]$$

where

$$P\_f\_indicator\_T = \begin{cases} 0.5061 & \text{if } P\_f = F \\ -0.2006 & \text{if } P\_f = G \\ 0 & \text{if } P\_f = X \end{cases}$$

#### Step 2: $TPI_{revised}$ Calculation

- Uses the MuHat Calculation and incorporates five-year accidents to calculate the revised TPI:

#### **Equation 4-5 Revised TPI Using MuHat**

$$TPI_{revised} = 1000 \times \hat{\mu} \times (A_5 + 0.1)$$

Where:

$\hat{\mu}$  = predicted number of crashes per year for each crossing

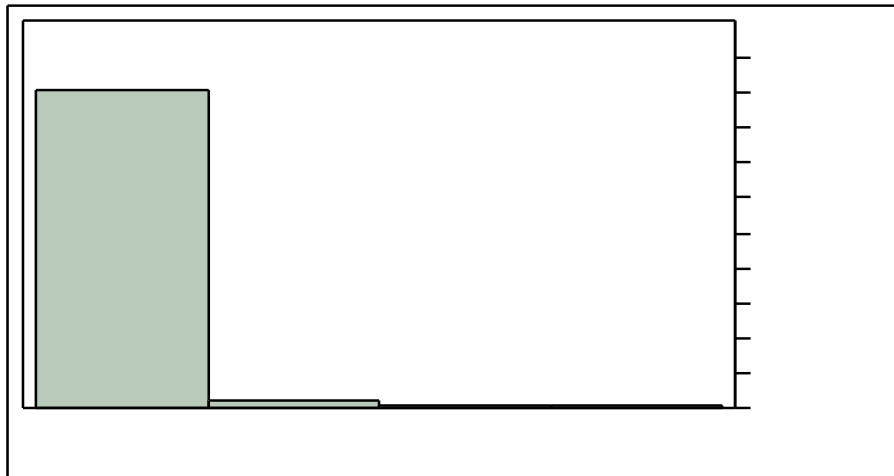
$A_5$  = number of crashes in last five years.

## Assessment of Performance of Revised TPI and Comparison with Existing TPI

Researchers were interested in assessing the performance of the revised TPI in terms of identifying potentially hazardous crossings. To ensure an objective assessment of the performance of the revised TPI, validation of  $TPI_{revised}$  was performed on a separate set of crashes (crashes occurred in 2011 at 9,108 crossings considered) that was used neither for deriving the prediction equation nor for obtaining  $A_5$ . Note that  $TPI_{revised}$  can be computed only for the crossings with no missing values for crossing characteristic variables (predictors) used in the prediction equation for  $\hat{\mu}$ , i.e., for P\_f, HwyPaved, UrbanRural, TrafLane, TotalTrack, ActualSD1, MaxSpeed, MinSpeed, TotalTrn, AADTF, NearbyInt, and Higher\_SPD\_Lmt. Out of 9,741 open public at-grade crossings originally considered, 9,108 crossings have no missing values for the above variables and have the corresponding  $TPI_{revised}$  values.

The total number of crashes in 2011 at 9,108 crossings was 159. Figure 4-3 shows the distribution of 2011 crashes per crossing at those 9,108 crossings. As can be expected, most crossings (about 98 percent of crossings) have zero crash. Only a little over 1 percent of crossings have one crash, and less than 1 percent of crossings have at least 2 crashes in 2011.

### Crash 2011



Frequencies		
Level	Count	Prob
0	8963	0.98408
1	134	0.01471
2	8	0.00088
3	3	0.00033
Total	9108	1.00000

Figure 4-3 Distribution for 1-year (2011) Accident Frequency

It was of interest to find out how many of the year 2011 crashes can be captured by a small subset of crossings with highest  $TPI_{revised}$  (i.e., crossings identified as having the highest crash risk). Researchers ordered the 9108 crossings according to the value of  $TPI_{revised}$  and counted



how many of 159 crashes in 2011 occurred at the crossings belonging to the top 1 percent, 2 percent, and 25 percent ranked crossings, respectively. Table 4-6 contains the result for  $TPI_{revised}$  as well as that for  $TPI_{old}$ . As can be observed from Table 4-6, 13 percent (21 out of 159), 21 percent (34 out of 159), and 59 percent (94 out of 159) of the year 2011 crashes are included in the top 1 percent, top 2 percent, and top 25 percent of ranked crossings by  $TPI_{revised}$ , respectively, and 10 percent (16 out of 159), 15 percent (23 out of 159), and 57 percent (90 out of 159) of the year 2011 crashes are included in the top 1 percent, top 2 percent, and top 25 percent of ranked crossings by  $TPI_{old}$ , respectively. It appears that overall the performance of  $TPI_{revised}$  is better than that of  $TPI_{old}$ .

**Table 4-6 Percentage of 2011 Crashes Captured by Top Proportions of Ranked Crossings**

	Top 1% (91 crossings)		Top 2% (182 crossings)		Top 25% (2277 crossings)	
	# of 2011 crashes captured	percent	# of 2011 crashes captured	percent	# of 2011 crashes captured	percent
$TPI_{revised}$	21	13%	34	21%	94	59%
$TPI_{old}$	16	10%	23	15%	90	57%

Note: 1. Total number of crossings with no missing predictors (N) = 9,108. 2. Total number of 2011 crashes occurred at 9,108 crossings =159. 3.  $TPI_{old}$  = calculated TPI from existing equation using formulated data

The  $TPI_{revised}$  was also compared with  $TPI_{old}$  in terms of the ranks of 9,108 crossings obtained by them. Spearman's rank correlation coefficient ( $r_s$ ), which is the correlation coefficient calculated on ranks, was used to assess the relationship between the ranks by  $TPI_{revised}$  and the ranks by  $TPI$ . The Spearman's rank correlation coefficient value for  $TPI_{revised}$  and  $TPI$  was 0.7670, which indicates that there is a moderately strong positive relationship between the rank orders by two indices although there are still some differences. The closer to 1 the value of Spearman's rank correlation coefficient is, the more similar the ranks from two indices are. If the value of the Spearman's rank correlation coefficient is 1, it means that the ranks by two indices are exactly the same.

Because the sample size used in this validation study (159 crashes) is rather small, researchers recommend that the validation study be performed as new crash data get available each year and the results be accumulated. It needs to be emphasized that crashes used for validation and crashes used for computing  $TPI_{revised}$  values ( $A_5$ ) need to be separated for objective evaluation. For example, if  $A_5$  (most recent 5 year crash history) comes from the years 2007–2011, then the validation set of crashes should be for the year 2012. Although the coefficients of the variables in Equation 4-3 can be used as default coefficients, it is recommended that the coefficients be recalibrated whenever substantial changes in the crossing characteristic variables are expected (e.g., every 5 to 10 years).

## CHAPTER 5 WARRANTS FOR PASSIVE CROSSINGS

### Warrants' Objectives and Underlying Principles

This project developed an efficient way to identify low-volume crossings that may be candidates for improvements. These crossings serve relatively few vehicles, are primarily passive, and the vast majority has no crash history. As discussed in [Chapter 1](#), the existing Texas Priority Index (TPI) assigns low priorities to low-volume crossings (see [Table 1-1](#)). This is due to a characteristic common to all highway-rail crossing priority indices found in the literature (see [Chapter 2](#) and [Appendix 1](#)); it is mathematically impossible for the same index to simultaneously consider the crossing exposure and prioritize low-volume crossings with safety concerns. Hence, several agencies base their decisions on a combination of an index and a set of rules to select passive crossings for improvements. TxDOT, too, identified the need for a methodology to identify and rank passive crossings that can potentially benefit from upgrades.

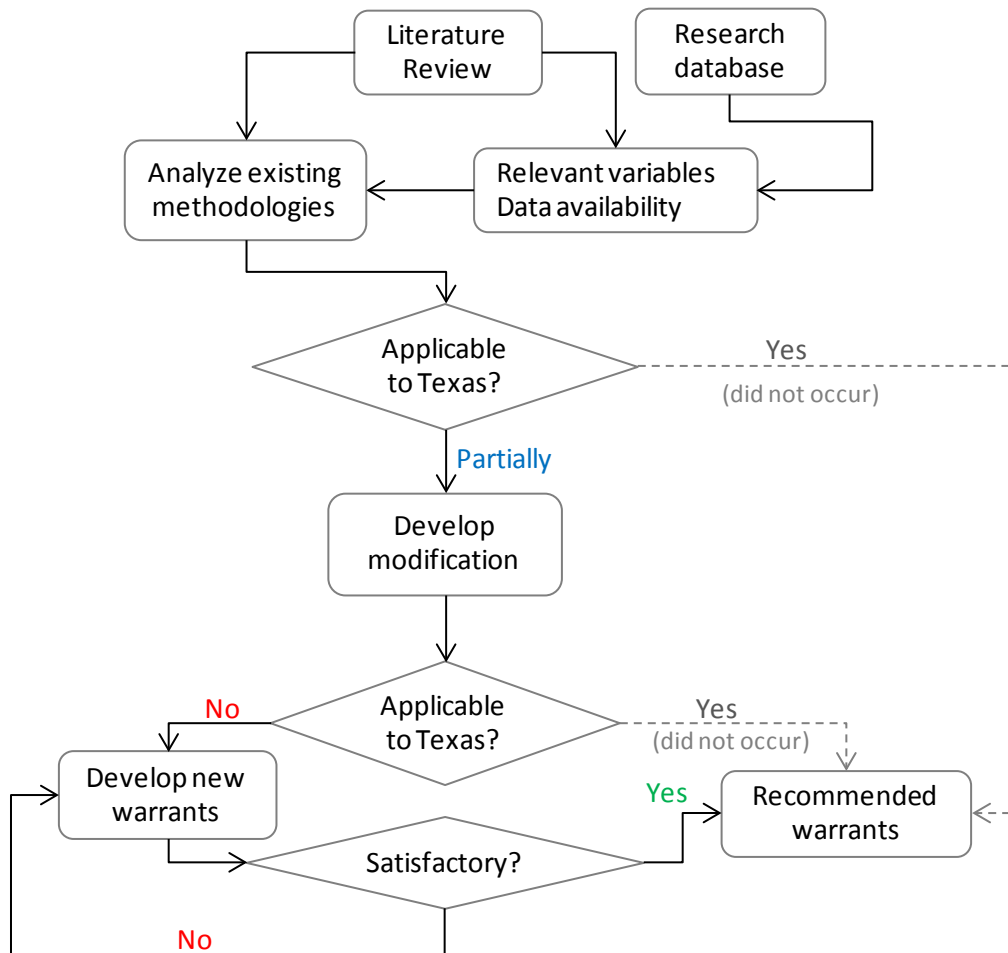
The warrants for Texas passive crossings were developed based on the following basic considerations and principles:

- Compatibility with TxDOT's Rail Division practices. When a crossing becomes candidate for an upgrade, an engineering team decides the type of improvement after one or more inspections, often followed by further study. The warrants should be a network-level decision aid tool to select candidates for these inspections, rather than rules relating specific protection devices to data thresholds.
- Initial eligibility. The warrants are applicable to open, public, passive crossings that either had one or more accidents in the past five years or serve at least two trains per day. Other eligibility restrictions were developed in this project and are discussed in this chapter.
- Applicability as a rail crossing management tool. All warrants must refer to information available in TxDOT's rail databases and ensure that all crossings with potential issues are considered.
- Permanence. Warrant thresholds should remain meaningful as overall conditions change over time.

### Research Approach

The first step consisted of identifying methodologies found in the literature with potential adaptability to the above principles and to Texas conditions, applying them to Texas data and analyzing the results. This step provided an excellent background for the selection of warranting variables, criteria, and thresholds. Several tentative sets of warrants were discussed with the Project Monitoring Committee (PMC) and repeatedly refined to arrive at the final warrants recommended in this project. All variables recommended by the PMC were included in the final warrants. [Figure 5-1](#) shows a summary of the research approach used to develop the warrants.

The remaining sections of this chapter document these research steps in chronological order, starting with the analysis of existing procedures and the conclusions drawn, followed by a thorough discussion of the warrants and their variables. The chapter ends with the implementation of the recommended set of warrants using TxRAIL 2011 data.



**Figure 5-1 Research Approach—Warrants**

### **Analysis of Existing Methodologies**

European guidelines were investigated during the literature review and found inadequate to represent the conditions prevalent at Texas passive crossings. European standards emphasize grade separation and place great significance on passenger trains, high-speed trains, and pedestrian traffic. More importantly, they are not designed as decision-aid tools to select and rank passive crossings for inspections targeting potential improvements. Rather, they are standards based on all or some of the following variables: daily train traffic, daily vehicular traffic, exposure, train speed, and sight distance. The Spanish guidelines, for example, are

extremely strict, recommending either closure or grade separation of any crossing with exposure above 1500 vehicles\*trains/day (refs. [8](#), [14](#), [15](#), [16](#), [22](#), [24](#)).

Four sets of national guidelines showed potential for adaptability to Texas passive crossings project and were further analyzed:

- Idaho Department of Transportation (ID-DOT).
- Illinois Department of Transportation (Illi-DOT).
- Federal Highway Administration (FHWA).
- Florida Department of Transportation (FL-DOT).

## **Idaho Department of Transportation**

### *Description*

The ID-DOT methodology has guidelines for post-mounted flashing signals, cantilevered flashing signals, automatic gates, and bells (ref. [10](#)). These guidelines are based on low, medium, and high values of the following crossing characteristics: annual average daily traffic (AADT), average daily train traffic (ADTT) highway speed, train speed and accident history, in addition to other variables such as sight distance obstructions. [Table 5-1](#) shows ID-DOT's thresholds for low, medium, and high values of AADT, ADTT, highway speed, and train speed.

Flashers are required if one or more of the conditions below are met:

- One or more accidents in the past five years.
- Sight distance obstruction in one or more quadrants.
- At least one of the following conditions: medium AADT, medium ADTT, medium highway speed, high train speed (rural area), medium train speed (if urban).
- Substantial number of school bus crossings.
- Substantial number of vehicles carrying hazardous materials.
- A diagnostic team determines post-mounted or cantilevered flashers are required.

Cantilevered flashers are required when at least one of the following conditions is met:

- There are distractions near or beyond the crossing that would compete for the driver's attention, especially other light sources.
- Traffic or parking conditions are such that the view of a post-mounted flasher could be blocked.
- Multilane highways.
- A diagnostic team determines that cantilevered flashing lights are required.

**Table 5-1 ID-DOT Definitions of Low, Medium, and High Values (Ref. 10)**

		<b>Rural Areas</b>	<b>Urban Areas</b>
<b>AADT</b>	<i>Low</i>	up to 750	up to 2,500
	<i>Medium</i>	751 to 3,000	2,501 to 5,000
	<i>High</i>	Greater than 3,000	Greater than 5,000
<b>ADTT</b>	<i>Low</i>	up to 2	up to 6
	<i>Medium</i>	3 to 9	7 to 12
	<i>High</i>	Greater than 9	Greater than 12
<b>Highway Speed (mph)</b>	<i>Low</i>	up to 20	up to 15
	<i>Medium</i>	21 to 40	16 to 34
	<i>High</i>	Greater than 40	Greater than 34
<b>Train Speed (mph)</b>	<i>Low</i>	up to 35	up to 15
	<i>Medium</i>	36 to 90	16 to 35
	<i>High</i>	Greater than 90	Greater than 35

Bells should supplement flashers in all urban crossings with other active protection. For other conditions, a diagnostic team determines if bells are required.

Automatic gates should supplement flashers under either one of following conditions:

- Crossings with multiple main line tracks.
- All multiple track crossings which may have more than one train or locomotive occupying the crossing at the same time.
- Crossings with high-speed passenger trains combined with medium to high vehicular speeds and volumes.
- A diagnostic team determines that automatic gates are required.

*Implementation*

Selecting protection devices based only on network-level data is not TxDOT’s Rail Division practice. As such, ID-DOT’s guidelines for each protection type were consolidated into a single set of rules. Rules involving data not available at TxDOT (e.g., hazardous materials) and those involving active crossings were removed. The two rules about multiple tracks were simplified, since there is no information to determine whether or not a train or locomotive may hide another on multiple track crossings. The rule involving high-speed passenger trains is not relevant in Texas, where an insignificant number of passive crossings serve passenger trains of any speed.

Finally, rules specific to cantilevered flashers were removed, since this type of decision is made after site inspections.

The term “substantial number of school buses” was defined as the 95 percent cumulative percentile of the daily school buses, calculated only for crossings that do have these buses (i.e., not considering zeroes). For 2010 data, the threshold was 12. Multiple tracks were defined as 2 or more tracks, regardless of whether or not they are main tracks.

Warrants based on the modified ID-DOT standards with ID-DOT thresholds would indicate that a passive crossing becomes candidate for upgrades if at least one of the five conditions below is met:

1. One or more accidents in the past five years.
2. Sight distance obstruction in one or more quadrants. Note: this rule is important and therefore was maintained, but it was not applied. TxRAIL sight distance data are being updated; they currently indicate over 1,400 crossings with sight distance obstructions, and most of those have been resolved.
3. At least one of the following conditions:
  - Medium or greater AADT.
  - Medium or greater ADTT.
  - Medium or greater highway speed.
  - High train speed if rural area.
  - Medium or greater train speed if urban area.
4. Number of school buses per day  $\geq$  12.
5. Two or more tracks.

### *Conclusions*

These warrants were applied to the subset of 3,082 public, open, passive crossings with two or more trains per day (or any train traffic if there were accidents) found in the research database (primarily 2010 data). Out of these, 2,810 met at least one of these warrants. A final version of the warrants including the additional variables recommended by the PMC would qualify nearly all passive crossings.

## **Federal Highway Administration**

### *Description and Implementation*

The Federal Highway Administration (FHWA) methodology has guidelines to upgrade, close, and grade-separate crossings. Those applicable to this research’s objectives are listed below, followed by a discussion of their implementation using the research database.

The FHWA guidelines indicate that active devices should be considered when at least one of the following conditions is met (refs. [32](#), [33](#)):

1. Multiple tracks exist at or in the immediate crossing vicinity where the presence of a moving or standing train on one track effectively reduces the clearing sight distance below the minimum relative to a train approaching the crossing on an adjacent track (absent some other acceptable means of warning drivers to be alert for the possibility of a second train).  
IMPLEMENTATION is not possible, since the data base has no information about the visibility issue. Multiple tracks are present in 620 crossings.
2. An average of 20 or more trains per day.  
IMPLEMENTATION: 8 percent of all passive crossings satisfy this criterion (92% percentile).
3. Posted highway speed exceeds 64 km/hr. (40 mph) in urban areas or exceeds 88 km/hr. (55 mph) in rural areas.  
IMPLEMENTATION: these thresholds correspond to the 97% percentile in urban areas and 99 percent in rural.
4. AADT exceeds 2,000 in urban areas or 500 in rural areas.  
IMPLEMENTATION: 89% percentile, or 11 percent of all passive crossings in urban areas, and 90% percentile in rural areas.
5. Multiple lanes of traffic in the same direction of travel (usually this will include cantilevered signals).  
IMPLEMENTATION was not recommended because less than 3 percent of all passive crossings have more than 2 lanes.
6. The crossing exposure (the product of the number of trains per day and AADT) exceeds 5,000 or 4,000 in rural areas.  
IMPLEMENTATION: 77 percent percentile in urban areas and 94% percentile in rural areas.
7. The expected accident frequency as calculated by the U.S.DOT Accident Prediction formula, including five-year accident history, exceeds 0.075.  
IMPLEMENTATION: 87 passive crossings met this criterion.
8. An engineering study indicates that the absence of active devices would result in the highway facility performing at a level of service (LOS) below level C.  
IMPLEMENTATION is discussed below, after this list.

Capacity analysis is a complex subject requiring a specific engineering study using data beyond TxRAIL's scope. For research purposes, Guideline 8 above was analyzed based on the general assumptions listed below.

- A passive rail crossing can function as a stopped controlled intersection.
- 50-50 directional split.
- Design hourly factor=  $K \cdot \text{AADT}$  in one direction.
- K-values are 10 percent for urban areas and 15 percent for rural areas.
- Capacity assumed as 1,100 private cars per hour.

As expected due to the prevalence of low AADTs, none of the passive crossings presented LOS below C (ref. 30).

*Conclusions*

The implementation of FHWA standards modified as discussed above resulted in 810 crossings warranted for automatic gates. Out of these, 272 crossings (33.6 percent of the warranted crossings) met more than one threshold. [Table 5-2](#) depicts these results.

**Table 5-2 Results of the FHWA Methodology**

Trains/Day	Hwy Speed	AADT	Exposure	Accident Prediction	Lanes	LOS	Crossings meeting Warrants
✓	✓	.	✓	.	.	.	1
✓	.	✓	✓	✓	.	.	2
✓	.	✓	✓	.	✓	.	1
✓	.	✓	✓	.	.	.	4
✓	.	.	✓	✓	.	.	5
✓	.	.	✓	.	.	.	37
✓	.	.	.	✓	.	.	9
✓	.	.	.	.	✓	.	1
✓	.	.	.	.	.	.	224
.	✓	✓	✓	✓	.	.	1
.	✓	✓	✓	.	✓	.	2
.	✓	✓	✓	.	.	.	9
.	✓	✓	.	.	.	.	8
.	✓	.	.	.	.	.	20
.	.	✓	✓	✓	✓	.	2
.	.	✓	✓	✓	.	.	11
.	.	✓	✓	.	✓	.	23
.	.	✓	✓	.	.	.	128
.	.	✓	.	✓	.	.	2
.	.	✓	.	.	✓	.	7
.	.	✓	.	.	.	.	117
.	.	.	✓	✓	.	.	12
.	.	.	✓	.	✓	.	7
.	.	.	✓	.	.	.	134
.	.	.	.	✓	.	.	43
Warranted set							810
Total crossings meeting no warrant							2,279
Total crossings analyzed							3,089



The prevalent thresholds for meeting these warrants were as follows:

- Trains > 20/day: 224 crossings (27.6 percent of the warranted crossings).
- Crossing exposure for urban areas > 5000 and for rural areas > 4000: 134 crossings (16.5 percent of the warranted crossings).
- Vehicular AADT for urban areas > 2000; rural areas > 500: 117 crossings (14.4 percent of the warranted crossings).

The accident prediction formula relies on normalized constants that need to be periodically adjusted (ref. 34). In this case, 87 crossings met the expected accident frequency warrant, while there were 234 crossings with accidents in that period. This accident prediction formula is not recommended for Texas passive crossings.

### **Illinois Department of Transportation**

#### *Description*

The Illinois Department of Transportation (Illi-DOT) has a formal methodology to recommend highway-rail crossing upgrades. In the case of passive crossings, the methodology indicates whether the crossings should have gates and flashers or flashers only. At a minimum, passive crossings must have reflective crossbucks, pavement markings where possible, and advance warning signs (ref. 11).

The Illi-DOT methodology starts with the estimated crash frequency (ECF) calculated as depicted in Equation [5-1] A passive crossing qualifies for active devices when  $ECF > 0.02$  (equivalent to 2 crashes in 10 years).

$$ECF = A B T \quad [5-1]$$

Where:

ECF = Expected crash frequency (multiply by 10 to obtain expected crashes in 10 years).

A = Traffic factor (see Table 5-3)

B = Component factor (see Table 5-4)

T = Number of trains per day.

When  $ECF > 0.02$ , and one or more of the conditions listed below are met, the crossing qualifies for gates and flashers. Otherwise, it qualifies for flashers only (ref. 11).

- Multiple mainline tracks.
- Multiple tracks at or in the vicinity of the crossing which may be occupied by a train or locomotive, so as to obscure from view the movement of another train approaching the crossing.
- High-speed train operation combined with limited sight distance at either single or multiple track crossings.

- A combination of high speeds and moderately high volumes of highway and railroad traffic.
- Either a high volume of vehicular traffic, high number of train movements, substantial numbers of school buses or trucks carrying hazardous materials, unusually restricted sight distance, continuing crash occurrences, or any combination of these conditions.
- The ECF for flashing lights exceeds 0.02 and the benefit/cost (B/C) ratio equals or exceeds 1.0.
- A diagnostic team recommends gates and flashers.

**Table 5-3 Illi-DOT Traffic Factors (Ref. 11)**

<i>Average Daily Traffic (10-yrs)</i>	<i>Traffic Factor "A"</i>
250	0.000347
500	0.000694
1000	0.001377
2000	0.002627
3000	0.003981
4000	0.005208
5000	0.006516
6000	0.007720
7000	0.009005
8000	0.010278
9000	0.011435
10,000	0.012674
12,000	0.015012
14,000	0.017315
16,000	0.019549
18,000	0.021736
20,000	0.023877
25,000	0.029051
30,000	0.034757

**Table 5-4 Illi-DOT Component Factors (Ref. 11)**

<i>Device</i>	<i>B Factor</i>
Crossbucks, ADT < 500	3.89
Crossbucks, urban	3.06
Crossbucks, rural	3.08
Wigwags	0.61
Flashing lights, urban	0.23
Flashing lights, rural	0.93
Gates, urban	0.08
Gates, rural	0.19

The method for determining the benefit-cost ratio consists of the three basic steps listed below (ref. 11):

- Step 1: Calculate the difference between the future ECF (proposed protection) and the present ECF (current protection).
- Step 2: Calculate the benefit by multiplying the annual savings by the crash cost,  $Z$ , where  $Z$  equals the ratio of deaths and injuries per crash (average for latest 3 years in Illinois) by the cost per crash ( $Z$  by Step 3). Use the National Safety Council crash cost data (ref. 17).
- Step 3: Calculate the annual cost of the proposed installation, which is the sum of the installation or construction cost divided by the expected life, plus the annual cost of maintenance.
- Step 4: Obtain B/C by dividing the benefit (B) by the annual cost (Step 2/Step 3).

### *Implementation*

According to the Illi-DOT method modification, a crossing meeting any of the 8 warrants listed below would qualify for inspections, since devices will not be selected based only on warrants. Several thresholds were developed and tested before arriving at the thresholds listed below. The warrant about hazardous materials (haz-mat) trucks was removed because this information is not available in TxRAIL.

1. Mainline Tracks > 1 (19 crossings).
2. Multiple tracks at or in the vicinity of the crossing occupied by a train or locomotive (1 crossing).
3. Vehicular AADT for urban areas > 2,000 (11 percent of passive crossings) and AADT for rural areas > 500 (10 percent of passive crossings).
4. Trains/day > 20 (8 percent of passive crossings).
5. School buses/day > 4 (10 percent of passive crossings).
6. Crashes > 2 in 5 years (1 percent of passive crossings).
7. Trucks carrying hazardous materials/day > 3 (data not available, estimated as 6 percent of truck volume, resulting in 8 percent of passive crossings).
8. ECF > 0.02 and benefit/cost ratio  $\geq$  1.0. Assumptions for this warrant are:

Casualty costs:	Fatality	\$4,166,209
	Injury	\$324,509
	Property Damage	\$8,137

Installation and maintenance cost for gates and flashers are \$180,900 and \$4,300/yr, respectively.

Expected life for gates and flashers is 25 years.

Table 5-5 shows the 856 crossings that met the modified Illi-DOT warrants for gates and flashers. As stated before, modification 2 does not have a warrant for flashers.

**Table 5-5 Illi-DOT Modification: Results**

Multiple Tracks	Obstruction	AADT	Trains/day	School Buses	Crash Occurrence	ECF	Crossings meeting Gates & Flashers Warrant
✓	.	✓	✓	.	.	✓	1
✓	.	✓	.	.	.	.	1
✓	.	.	✓	.	.	✓	2
✓	.	.	✓	.	.	.	6
✓	.	.	.	✓	.	✓	1
✓	.	.	.	.	.	✓	2
✓	.	.	.	.	.	.	6
.	✓	.	.	✓	.	.	1
.	.	✓	✓	.	✓	✓	1
.	.	✓	✓	.	.	✓	5
.	.	✓	.	✓	✓	✓	1
.	.	✓	.	✓	.	✓	19
.	.	✓	.	✓	.	.	17
.	.	✓	.	.	✓	✓	2
.	.	✓	.	.	.	✓	131
.	.	✓	.	.	.	.	139
.	.	.	✓	✓	.	✓	2
.	.	.	✓	.	✓	✓	1
.	.	.	✓	.	.	✓	35
.	.	.	✓	.	.	.	231
.	.	.	.	✓	.	✓	10
.	.	.	.	✓	.	.	99
.	.	.	.	.	✓	✓	1
.	.	.	.	.	✓	.	3
.	.	.	.	.	.	✓	139
Total gates & flashers							856
Warrants not met							2,233
Total							3,089

The prevalent thresholds for meeting modification 2 warrants (see Table 5-5) were as follows:

- Train volume  $\geq 20$ /day: 231 crossings (27.0 percent of the warranted crossings).
- Vehicular AADT  $> 2000$  for urban areas; or AADT  $> 500$  for rural areas: 139 crossings (16.2 percent of the warranted crossings).



## Conclusions

The analysis of Illi-DOT's warrants provided useful information and several tentative thresholds used when developing the final warrants. Illi-DOT's ECF index does not appear accurate for Texas passive crossings and is not recommended.

## Florida Department of Transportation Methodology

### Description

The Florida Department of Transportation (FL-DOT) methodology uses a Safety Hazard Index (SHI) as a criterion to determine if a crossing needs improvement. A crossing is considered for improvement if its SHI is below 60. Scores between 60 and 70 are considered borderline and scores above 70 are not considered for improvement (ref. 18).

The SHI calculation starts with the predicted semi-annual crash probability " $p$ " calculated based on Equation [5-2] for flashers and on Equation [5-3] for gates (ref. 18).

$$y = -8.242 + 0.601 \log_{10}[(t + 0.5)AADT] + 0.012HS + 0.016MTS + 1.137trk + 1.648L - 0.877 * G \quad [5-2]$$

$$y = -7.959 + 0.554 \log_{10}[(t + 0.5)AADT] + 0.015HS + 0.014MTS + 1.032trk + 1.54L - 0.801 * F \quad [5-3]$$

Where:

$y = \ln\left(\frac{P}{1-P}\right)$  and " $p$ " is the semi-annual crash probability.

t = daily trains.

AADT = annual average daily traffic.

HS = highway speed.

MTS = maximum train speed.

trk = number of tracks.

L = number of lanes.

G = 1 if gates are present, 0 if not.

F = 1 if flashers are present, 0 if not.

Based on the semi-annual crash probability " $p$ ," the predicted number of crashes per year " $P$ " is obtained as follows:

$$y = \ln\left(\frac{p}{1-p}\right) \rightarrow p = \frac{e^y}{1+e^y} \rightarrow P = \frac{2e^y}{1+e^y} \quad [5-4]$$

When the crash history is greater than the crash prediction, “*P*” is adjusted for the observed crash history as depicted in Equation [5-5]. The maximum annual crash probability is then used in Equation [5-6] to calculate the FL-DOT Safety Hazard Index (SHI).

$$P^* = P \sqrt{\frac{H}{PT}} \quad [5-5]$$

Where

*P* = Predicted number crashes per year.

*P*\* = Adjusted number crashes per year.

*H* = Number of crashes in the past six years or since most recent warning device upgrade (crashes in 5 years were considered for the implementation in Texas).

*T* = Number of years of crash history (5 years were considered during implementation).

$$SHI = 90 \left( 1 - \sqrt{\frac{P^*}{MaxP}} \right) - 5[\log_{10}(B + 1)F] \quad [5-6]$$

Where

*MaxP* = Maximum value for the crash prediction.

*B* = Number of school buses.

*F* = 1 if active devices are present, 2 if passive.

In addition to the safety index, Rule 14-46.003 of the Florida Administrative Code requires gates under any of the conditions listed below (ref. 7).

1. Multi-lane highway.
2. Multiple mainline railroad tracks including passing tracks.
3. Multiple tracks at or adjacent to the highway railroad grade crossing that may be occupied by train resulting in the view obstructing the movement of another train approaching the highway railroad grade crossing.
4. High speed train operation greater than 65 mph (110 km/h) or commuter train operation greater than 45 mph (70 km/h).
5. Traffic greater than 5,000 vehicles per day.
6. More than 30 through trains per day.

7. More than 9 school buses per day.
8. Substantial number of trucks carrying hazardous materials.
9. Continuance of crash history after the installation of flashing lights.
10. Intersection that has traffic signals and/or heavy turning movements from a parallel highway onto the tracks within 200 feet (60 m) measured from the edge of the travel way.

*Implementation*

The Florida method was adapted to Texas conditions, resulting in 7 warrants. There are no data for warrants 3 and 8. For warrant 10, there is only partial information. Parallel highway and its distance to the crossing are available. However, there are no turning movement counts, and the variable recording the presence of a nearby traffic signal does not indicate its location with respect to the crossing. Warrant 4 was simplified due to availability of the maximum timetable speed in the database, and the threshold was changed to 49 mph, which is the recommended speed when there are no track signals (ref. 36). Warrant 9 was modified to “crash history of 2 or more accidents” and makes no reference to active devices. The list below shows the adapted set of 7 warrants and the number of crossings meeting each of them.

1. Multi-lane highway .....	89
2. Multiple mainline railroad tracks including passing tracks.....	190
3. Train faster than 49mph .....	737
4. Traffic greater than 5,000 vehicles per day .....	105
5. More than 30 through trains per day .....	101
6. More than 9 school buses per day .....	65
7. Two or more crashes in the past 5 years. ....	31

These 7 warrants were applied to the subset of the research database consisting of open, public, passive crossings serving 2 or more trains per day, plus those with crash histories (regardless of number of trains). A total of 1,131 crossings met at least one warrant. The number of crossings by number of warrants met was:

No warrants .....	1,951
1 warrant.....	963
2 warrants .....	151
3 warrants .....	15
4 warrants .....	2

The Florida SHI was calculated for the same subset of the research database, resulting in 29 passive crossings with SHI < 60, the previously discussed threshold to qualify for improvements. [Table 5-7](#) shows these 29 crossings and their Texas Priority Index (TPI).



**Table 5-7 Texas Passive Crossings Meeting Florida SHI<60 Qualification Threshold**

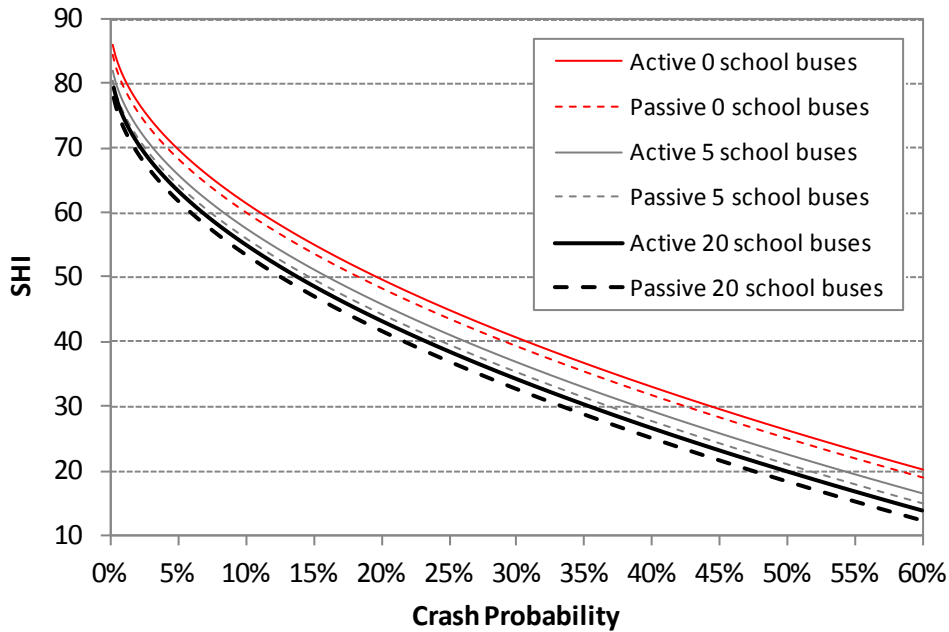
Rank by SHI	Crossing Number	TPI	SHI	Rank by SHI	Crossing Number	TPI	SHI
1	448229X	20387	44.56	16	331484E	585	57.47
2	276277K	28	48.94	17	923779H	180	57.82
3	023371A	930	52.32	18	758592J	65	57.90
4	276125N	504	53.61	19	793665J	399	57.98
5	790236V	55	54.09	20	014992W	871	57.99
6	427604M	109	54.36	21	426597B	163	58.02
7	021484Y	313	54.44	22	416311D	1706	58.65
8	793618B	2403	55.07	23	020841V	160	58.93
9	596178V	328	55.09	24	021663P	300	59.07
10	021585K	852	55.14	25	331431F	18	59.12
11	021505P	587	55.88	26	432359W	32	59.20
12	415440P	576	56.25	27	432746N	99	59.24
13	017624S	388	56.28	28	024398M	239	59.52
14	796359C	1332	56.77	29	024325C	235	59.85
15	427240P	72	57.07				

The discrepancy between the number of crossings meeting warrants and those qualifying based on SHI happened in spite of the fact that the SHI formula (see [Equation 5-6](#)) contains the factor F to ensure that the SHI of passive crossings is always less than that of active crossings with the same crash probability and the same number of school buses. [Figure 5-3](#) illustrates this SHI property.

*Conclusions*

The FL-DOT method implementation resulted in a significant discrepancy between the number of crossings meeting warrants (1,131) and those meeting the SHI index threshold (29 crossings). This further substantiates the need to treat active and passive crossings separately when preparing a priority list.

The FL-DOT method provided additional guidance for the final warrants. Researchers and the PMC decided to develop a warrant for parallel highway in conjunction with other known risk factors. Neither the SHI nor the Florida warrants include the presence of stopped sight distance obstructions, a very important safety issue that must be included in the final warrants as well as in the TPI revision.



**Figure 5-3 Florida Safety Index**

**Conclusions and Recommendations**

The Florida SHI is considerably stricter than all other methods investigated in this research. The Illi-DOT modification selected 856 and the FHWA method selected 810. Nevertheless, nearly all 29 crossings selected by the Florida methodology were also selected by the FHWA and the Illi-DOT methods. TPI, however, seldom prioritizes passive crossings over active ones. Considering the average funding availability and average cost of gates and flashers installation (ref. 29), there would be funds to improve at most 5 percent of all passive crossings each year. Therefore, a crossing must have a TPI in the top 5 percent in order to be considered for improvements. For the data used in this investigation, this means  $TPI > 857$ . Only 6 crossings meeting the  $SHI < 60$  threshold had TPI above this percentile (see Table 5-7), underscoring the need for a qualification and prioritization methodology that accurately reflects the characteristics of Texas passive crossings.

Table 5-8 summarizes the factors considered by different jurisdictions for rail-highway crossing upgrades. The four national guidelines all consider AADT, train volumes, number of highway lanes, number of tracks, accident history, and train speed. Idaho, Illinois, and Florida also consider other variables, such as school buses, haz-mat trucks, sight distance, urban/rural area, and presence of a highway parallel and close to the tracks. Passenger trains were considered only by the Idaho guidelines. AADT is the only variable present in all the international and national guidelines investigated in this research.

**Table 5-8 Summary of Variables Used by the Methodologies Analyzed**

Factors Considered	Agency or Jurisdiction						
	<i>ID-DOT</i>	<i>Illi-DOT</i>	<i>FHWA</i>	<i>FL-DOT</i>	<i>GERMANY</i>	<i>FRANCE</i>	<i>SPAIN</i>
Accident History	✓	✓	✓	✓			
Vehicular Volumes	✓	✓	✓	✓	✓	✓	✓
Train Volumes	✓	✓	✓	✓		✓	✓
Exposure			✓		✓	✓	✓
Vehicular Speed	✓		✓	✓			
Train Speed	✓	✓		✓	✓	✓	
School Buses	✓	✓					
Haz-Mat Trucks	✓	✓					
Highway Lanes	✓	✓	✓	✓			
Number of Tracks	✓	✓	✓	✓		✓	
Passenger Trains	✓						
Urban/Rural	✓	✓	✓				
Protection Device		✓	✓	✓			
Sight Restrictions	✓	✓	✓		✓	✓	
Highway Type			✓				
Parallel Highway				✓			
Paved Highway			✓				

These findings were used as initial guidance to start developing warrants that reflect the conditions prevalent in Texas passive crossings, as documented in the next section. Based on these analyses, the warrants must include crash history, AADT, train traffic, multiple tracks, school buses, sight distance obstructions, parallel highway in conjunction with other risk factors, vehicular and train speeds. In addition, the warrants must properly consider urban and rural areas.

## Texas Warrants for Passive Crossings

### Overview

The previous analysis indicated that a creative approach is necessary to develop warrants that meet the underlying principles laid out in the “Research Approach” section. These principles are repeated below for convenience.

- Compatibility with TxDOT’s Rail Division practices. When a crossing becomes candidate for an upgrade, an engineering team decides the type of improvement after one or more inspections that may be followed by a study. The warrants should be a

network-level decision aid tool to select candidates for these inspections, rather than rules tying specific protection devices to data thresholds.

- Initial eligibility. The warrants are applicable to open, public, and passive crossings serving at least two trains per day, plus all crossings that had one or more accidents in the past five years. Other eligibility criteria were developed in this project and are discussed later in this section.
- Applicability as a rail crossing management tool. The warrants must refer to information available in TxDOT's rail databases and ensure that all crossings with potential issues are considered.
- Permanence. Warrant thresholds should remain meaningful as overall conditions change over time.

The set of warranted passive crossings is obtained in a stepwise procedure. First, crossings that meet a series of non-qualification criteria are eliminated from further consideration, resulting in the *eligible set*. The warrants are applied to the *eligible set*, creating the *warranted set*. This set is then prioritized using the Texas Passive Crossings Index documented in the next chapter.

### **The Percentile Threshold Concept**

All methodologies for managing rail crossings found in the literature rely on one or more of the three concepts listed below:

- *Crash prediction models*. Example: FL-DOT safety hazard index (ref. 18).
- *Fixed thresholds*. Example: "AADT exceeds 2,000 in urban areas or 500 in rural areas" (ref. 33).
- *Qualitative thresholds*. Example: "Substantial number of school buses" (ref. 10).

The previously discussed analyses as well as TxDOT's practical experience indicate that crash prediction models are not the best way to evaluate Texas passive crossings, and that warrants are necessary to subset the passive crossing network into a warranted set to be prioritized for inspections. Warrants with fixed numeric thresholds have two important shortcomings:

1. Crossings with borderline values never have an opportunity to be considered for upgrades, and
2. The threshold values reflect data available at the time the warrants were developed and may become outdated in the future.

Qualitative thresholds can theoretically deal with these two limitations only if the numeric definition of adjectives such as substantial does not revert back to the fixed threshold situation. The idea behind "substantial school buses" can be accurately reflected by "the number of school buses per day greater than or equal to the 90% percentile of all crossings that serve school buses." Every year, the percentiles are recalculated for the new data, thus providing the following advantages:

- The recalculated percentile values corresponding to each warrant underlying concept (e.g., high AADT, significant truck traffic, etc.) self-adjust to reflect the latest data.
- Crossings with values close to a certain year’s percentile have the opportunity of being captured in a subsequent evaluation.
- The percent of crossing meetings each warrant does not change when the data changes.

Let’s examine what would happen in two consecutive years if one defines “substantial school buses” as “school buses/day  $\geq 10$ ,” the threshold found in ref. 7. This fixed threshold would qualify 66 crossings in 2010 and 44 in 2011. This translates into 50 percent more warranted crossings in 2010 than in 2011. This variability extends to all warrants based on fixed thresholds, thus affecting the applicability of the warrants as a rail crossing management tool in two ways:

- (1) The manager would not know what to expect in terms of the size of the warranted subset.
- (2) The borderline value of 9 school buses would never qualify—and in 2011, 7 percent of all crossings had values equal to or above 9.

Now let’s redefine the same “substantial school buses” warrant as “school buses per day greater than or equal to the 92% percentile value of all crossings that have school buses.” The warrant always qualifies 8 percent of the crossings with school buses every year. Crossings with 9 school buses, the borderline value of the previously discussed fixed threshold of 10, would not be considered in 2010 but would be considered in 2011, giving them a chance of being further evaluated.

During a project workshop held at the end of the first year of this two-year project, the participants discussed the advantages and disadvantages of using self-adjusting percentiles in lieu of fixed thresholds. The PMC requested additional research, approving the concept afterwards.

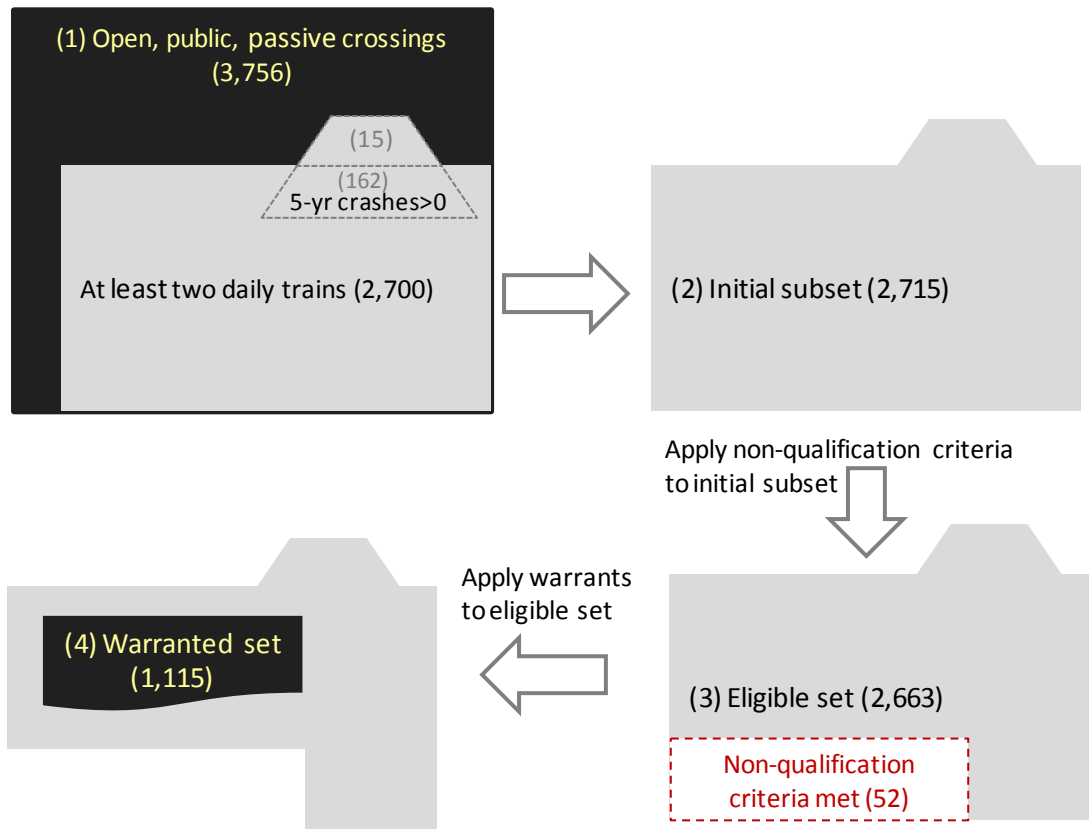
### **Non-Qualification Criteria and the Eligible Data Set**

A methodology based on percentile thresholds benefits from a two-step approach: first, use non-qualification criteria to eliminate crossings from further consideration, creating the *eligible set*; then, apply the warrants only to this set. Non-qualification criteria streamline the warranting process, decreasing the set to which warrants are applied and eliminating from further consideration crossings that have obviously low values of relevant variables regardless of their percentiles. [Figure 5-4](#) depicts an overview of the non-qualification and subsequent warranting procedure, illustrating the results with 2011 data.

#### Subset 1: Initial set of passive crossings.

The set of 3,756 open, public, passive crossings (yellow rectangle in [Figure 5-4](#)) is reduced to the initial set of 2,715 crossings by removing from further consideration all crossings that serve less than 2 daily trains (grey rectangle) unless they had one or more crashes in the past five years (top

portion of the trapezoid in [Figure 5-4](#)). The initial set criteria reflect funding rules and policies aimed at dealing with budgetary constraints.



**Figure 5-4 Overview of Warranting Procedure**

Subset 2: Eligible set of passive crossings.

The 10 non-qualification criteria described in [Table 5-9](#) are applied to the initial set and non-qualifiers are removed, resulting in the eligible set of 2,663 crossings (grey shape in [Figure 5-4](#)). They are eligible to be checked for warrants. These 10 additional non-qualification criteria were developed based on literature review and on statistical analyses of 2010 and 2011 data, submitted to the PMC, and further refined until satisfactory. A crossing can be removed from the initial subset when it meets all 10 non-qualification criteria described in [Table 5-9](#).

Subset 3: Warranted passive crossings.

The 10 warrants detailed in the next section are applied to the eligible set, resulting in the warranted set of 1,115 crossings, represented in orange in [Figure 5-4](#).

**Table 5-9 Non-Qualification Criteria**

<b>Criterion</b>	<b>Rationale</b>
1) No accidents in the past five years	One or more recent accidents may indicate the possibility of some risky situation that might benefit from an upgrade; the crossing will be further analyzed during the warranting procedure.
2) No multiple tracks	Multiple track highway-rail grade crossings consist of two or more in-service railroad tracks, where two or more trains can operate simultaneously. The presence of a train on one track may restrict the driver's view on an adjacent track. Moreover, multiple tracks increase the crossing time.
3) No passenger trains	The potential for injuries and fatalities in case of an accident substantially increases.
4) AADT below the median (50%) of the initial subset	The higher the AADT, the higher the potential for accidents. Note: the medians are calculated separately for urban and rural areas, over the entire <b>initial</b> subset. The medians can be estimated using a built-in "median" function.
5) Maximum timetable speed $\leq 30$ mph	The potential for fatalities and serious injuries increases with speed. A threshold of 30 mph was developed in concert with the PMC based on analyses of fatalities and serious injuries in past accidents (ref. 29).
6) Highway speed limit $\leq 30$ mph	Same as above
7) Daily trains $\leq 4$	High train volume increases exposure, which in turn increases the potential for incidents.
8) No stopped sight distance obstruction	A driver stopped at a passive crossing must be able to see far enough of the railroad track to be able to cross it safely. Note: data on sight distance obstructions are undergoing updates, so this criterion was not used in this report's results.
9) No nearby intersection	A nearby intersection appears to increase the potential for accidents (ref. 29).
10) Crossing angle $\geq 60^\circ$ *	Sharp angles between the highway and the railroad decrease visibility.

\*Note: TxRAIL variable: CrossingAngle = 3.

In TxRAIL, the crossing angle is stored in three corresponding to values of 1, 2, and 3:

- (1)  $0^\circ$  to  $29^\circ$
- (2)  $30^\circ$  to  $59^\circ$
- (3)  $60^\circ$  to  $90^\circ$

## Warrants for Passive Crossings

### *Introduction*

The warrants capture passive crossings presenting characteristics that might increase their potential for an incident. The 10 Texas Warrants for Passive Crossings were developed based on the analyses of existing guidelines, hazard indices and accident prediction formulas, and statistical analyses of TxRAIL data, while considering expert opinions from the PMC. Several variable combinations and threshold levels were developed and tested. Refined and/or new variable combinations and thresholds were developed to correct flaws and resubmitted to the PMC until approval of the final warrants (see [Figure 5-1](#) in the Research Approach section).

As previously discussed, variables representing vehicular and train traffic are present in all methodologies, rules, warrants, and indices found in the literature. This is because the probability of any event increases with the number of attempts (ref. 12). In order to streamline the explanation of the Texas Warrants, these two key variables, their product, the exposure, and the variable indicating urban and rural areas are discussed before the warrants. The other variables are discussed under each warrant that uses them.

Vehicular and train traffic often differ for urban and rural areas, so TxRAIL binary variable “UrbanRural” from GxFORM table is also used in the warranting procedure. It takes the value of 1 for urban and 2 for rural areas. UrbanRural information was absent for 142 crossings (31 blanks and 111 zeroes) in the set of open, public, passive crossings taken from TxRAIL 2010. The split between urban and rural passive crossings was approximately 40/60 percent. [Table 5-10](#) summarizes this variable for all open, public, passive crossings.

**Table 5-10 Variable UrbanRural (2010 Data)**

<b>UrbanRural Value</b>	<b>Crossings</b>	<b>Percent</b>
0	111	2.9%
Missing	31	0.8%
1 (urban)	1,470	38.2%
2 (rural)	2,236	58.1%
Totals	3,848	100.0%

### *Correct Percentile Calculation*

Several of the Texas warrants’ thresholds are cumulative percentiles, so it is imperative to understand the percentile definition used in the warrants before discussing the thresholds and variables. For warranting purposes, percentiles must always be calculated by counting the occurrences of every individual value of the variable, then calculating the cumulative count. The cumulative percentiles are the percent of each cumulative count with respect to the total count. This method ensures a unique percentile value for each variable value.

A definition commonly used in pre-programmed percentile (or quantile) functions sorts the data, divides it into equal size bins, and assigns each bin threshold to the respective percentile. When



the variable distribution has many repeated values, this method assigns different percentiles to the same value of the variable. Multiple data values corresponding to the same percentile threshold would cause problems in the warrants implementation. A simple example helps visualize this issue. In a data set with 10 percent of the records equal to the maximum value, the bin method will assign all percentiles greater than or equal to 90 percent to the maximum value.

[Table 5-11](#) provides an example that clearly illustrates the acceptable and unacceptable percentile calculations. It was prepared in Excel using a dataset with 1,843 variable values between 5 and 70, incremented by 5. The number of occurrences of each variable value in this illustrative dataset varies from just a few to more than half the size of the data set (note the number of occurrences of the value of 30). Exactly 91.5 percent of the data points are equal to or less than 30. Excel “percentile” function uses the bin method; therefore, when the function divided the data into 10 equal-size bins (see column “percentile input”), 7 bins contained nothing but 30, so the value of 30 corresponds to all 7 percentiles from 30 percent to 90 percent by 10 percent.

Built-in functions that take as inputs the desired percentiles or quantiles generally use the bin definition. Before using a built-in function for percentile calculations, it is imperative to test it with a large dataset that has a considerable number of repeated values. Upon request, we will provide the raw data that generated [Table 5-11](#). Do not use the built-in function if the results are similar to the last two columns of [Table 5-11](#).

Since counting the occurrences of each value in a dataset, calculating the cumulative count, and calculating percentages with respect to the total is a very simple procedure, it is recommended to perform the exact calculation rather than test built-in quantile or percentile functions. The only exception is the median calculation (50% percentile). A built-in function may use the bin method, but since the median divides the data into two halves, it will always return a unique value. A built-in median function can be used to simplify the implementation of the non-qualification criteria (see [Table 5-9](#)). All other percentiles calculated for warranting procedures must be calculated with exact counts.

**Table 5-11 Acceptable and Unacceptable Percentile Calculations**

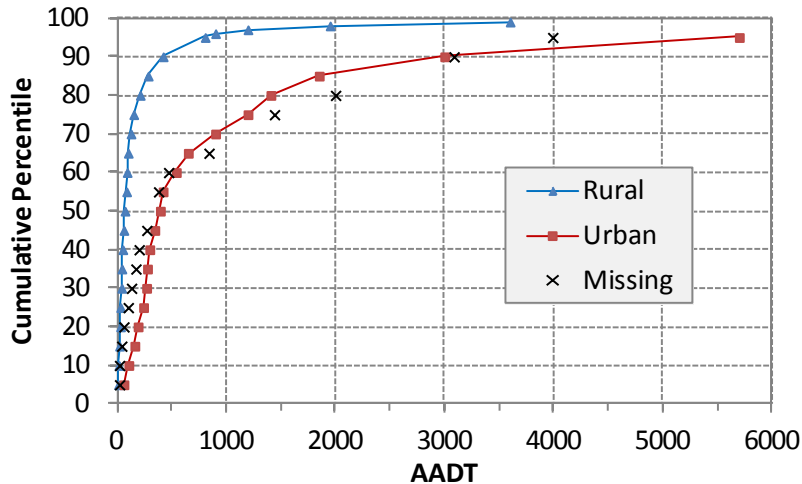
Variable value	ACCEPTABLE CALCULATION WITH EXACT COUNTS			UNACCEPTABLE CALCULATION	
	Occurrences in the dataset	Cumulative count	Cumulative percentile	Percentile function input	Percentile function output
5	5	5	0.3%	0%	5
10	129	134	7.3%	10%	20
15	34	168	9.1%	20%	25
20	193	361	19.6%	30%	30
25	63	424	23.0%	40%	30
30	1263	1687	91.5%	50%	30
35	68	1755	95.2%	60%	30
40	26	1781	96.6%	70%	30
45	29	1810	98.2%	80%	30
50	7	1817	98.6%	90%	30
55	18	1835	99.6%	100%	70
60	3	1838	99.7%	Function input	=Percentile(vector of 1843 values, previous column)
65	2	1840	99.8%		
70	3	1843	100.0%		
<b>How was obtained→</b>	=Frequency{vector of 1843 values, previous column}	Sum of consecutive cells	Cumulative count divided by 1843		

*Average Daily Traffic (AADT)*

One of the principal objectives of this project is to develop a crossing prioritization methodology that ensures a fair treatment of low-volume crossings. Since it is well-known that urban AADT is considerably higher than rural AADT, the warrants consider these AADTs separately to prevent urban crossings from outranking rural ones.

TxRAIL GxFORM table has two variables representing AADT: AADT and PAADT. TxRAIL uses PAADT in lieu of AADT when the former is present and greater than zero. This rule is embedded in the current prioritization index calculations. Investigation of 2010 data indicated 194 open, public, passive crossings where PAADT is less than AADT, so the maximum of the two was used during this research’s investigations in order to be conservative.

Figure 5-5 shows the cumulative distribution of AADT by the three values of the variable UrbanRural: urban (1), rural (2) and missing. Visual inspection of Figure 5-5 suggests that urban AADTs are significantly higher than those of rural crossings, and that the missing values appear to be statistically the same as urban. Two non-parametric tests of homogeneity, Kruskal-Wallis and Median Scores Test, confirmed this for both 2010 and 2011 data. Results and conclusions are summarized below. The minimum acceptable P-value for rejecting the null hypothesis is 0.05 (5 percent significance level, or a 5 percent probability of a wrong rejection) (ref. 12).



**Figure 5-5 AADT Cumulative Distribution (2010 Data)**

Null hypothesis:  $AADT(urban) = AADT(rural)$

2010 result: reject the null hypothesis at  $P\text{-value} < 0.01\%$  (significance level) in both tests.

2011 result: the same.

Null hypothesis:  $AADT(urban) = AADT(missing)$

2010 result: cannot reject the null hypothesis; P-values are 18% in Kruskal-Wallis test and 35% in the Median Scores test.

2011 result: cannot reject the null hypothesis; P-values are 99.4% in the Kruskal-Wallis test and 62% in the Median test.

Conclusions for research purposes:

- 1)  $AADT(urban) > AADT(rural)$
- 2)  $AADT(urban) = AADT(missing)$

In this research and its subsequent implementation, AADT percentiles are always calculated separately for urban and rural areas, according to the exact procedure described in the previous section. An AADT of zero was treated as a missing value. Missing and urban AADTs were statistically the same in 2010 and 2011 and were treated as such for research purposes. However, the recommended implementation procedure is to check the crossing location and properly populate the missing UrbanRural values in the new system.

### *Total Daily Trains*

This information comes from variable “TotalTrn” in TxRAIL table GxFORM. The distribution of this variable was investigated in a manner analogous to that used for AADT. Unlike  $AADT=0$ ,  $TotalTrn=0$  is a valid value representing less than daily trains. Therefore, the percentile calculation includes the zeroes. When calculating the exposure, use the value of 0.5 in lieu of zero (see next section). The overall impact of crossings with less than daily trains on the eligible

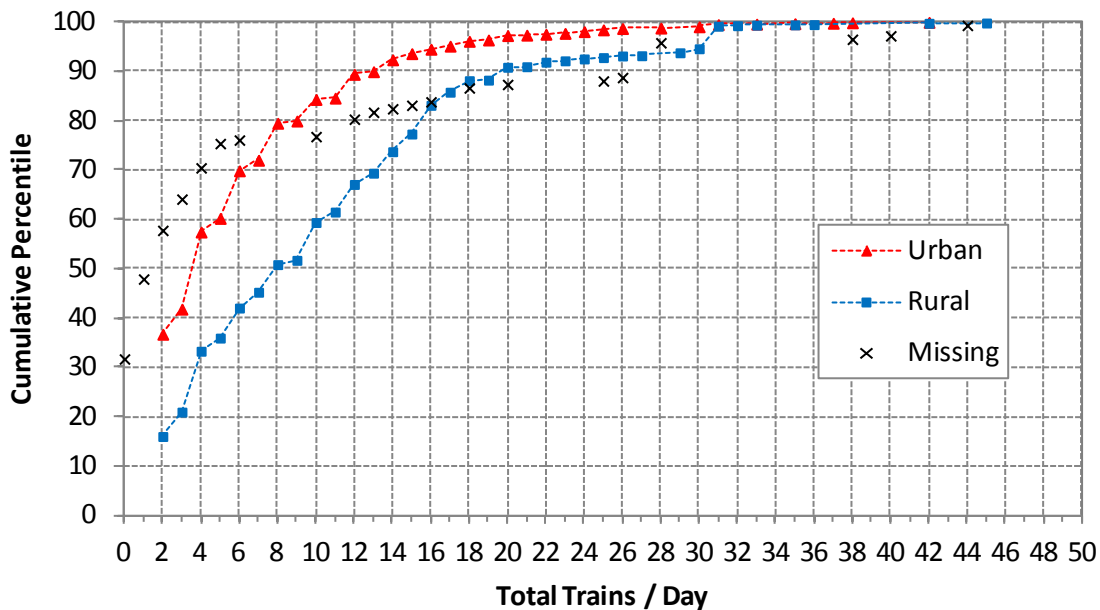
set is none to minimal, since crossings with less than two daily trains qualify for the eligible set only if they had at least one accident in five years. None qualified in 2011.

Figure 5-6 shows the cumulative distribution of daily trains by urban / rural. It suggests that urban crossings have significantly lower train volumes than rural crossings. Two non-parametric tests of homogeneity (Kruskal-Wallis and the Median Scores Test) confirmed this for both 2010 and 2011 data, at P-values less than 0.01 percent.

However, the missing urban/rural values did not perfectly fit the urban, as suggested by Figure 5-6. While the two homogeneity tests consistently rejected the hypothesis that the missing values came from the rural distribution in both 2010 and 2011 data, and neither test could reject the hypothesis that the missing values are urban for 2011 data, the 2010 results were mixed. The Median test rejected the null hypothesis that missing are urban, but the Kruskal-Wallis did not, albeit at a rather low P-value (7.5 percent). Results of all homogeneity tests are summarized below Figure 5-6. Given that all but one test indicated that missing values may be considered urban, and that the missing data distribution is predominantly below rural, the percentile calculations for research purposes considered missing train volumes as urban. This approximation is convenient for research purposes but is not recommended during implementation. Rather, it is recommended to populate the missing urban/rural values during implementation.

*Exposure*

This quantity is the product of AADT and the daily trains, and is calculated from the two previous TxRAIL variables, Totaltrn and either AADT or PAADT if the latter is available. Exposure is considered in most methodologies, guidelines, and indices investigated in the literature review, due to the fact that increased exposure means increased risk.



**Figure 5-6 Cumulative Distribution of Daily Trains (2010 Data)**

Null hypothesis:  $TotalTrn_{urban} = TotalTrn_{rural}$

2010 and 2011 results: reject the null hypothesis at P-value < 0.01% (significance level) in both tests.

Null hypothesis:  $TotalTrn_{urban} = TotalTrn_{missing}$

2010 results: reject the null hypothesis at P-value=2.5% (significance level) in the Kruskal-Wallis test, but cannot reject with the Median Test (P-value=7.6%)

2011 results: cannot reject the null hypothesis. P-values are 20.45% and 46.16%, respectively for the Kruskal-Wallis and the Median tests.

Null hypothesis:  $TotalTrn_{rural} = TotalTrn_{missing}$

2010 results: reject the null hypothesis at P-values < 0.01% in both tests.

2011 results: reject the null hypothesis at P-value=1.99% (significance level) in the Kruskal-Wallis test, and the Median Test (P-value=2.64%)

Conclusions for research purposes:

- 1)  $TotalTrn(rural) > TotalTrn(urban)$
- 2)  $TotalTrn(urban) = TotalTrn(missing)$

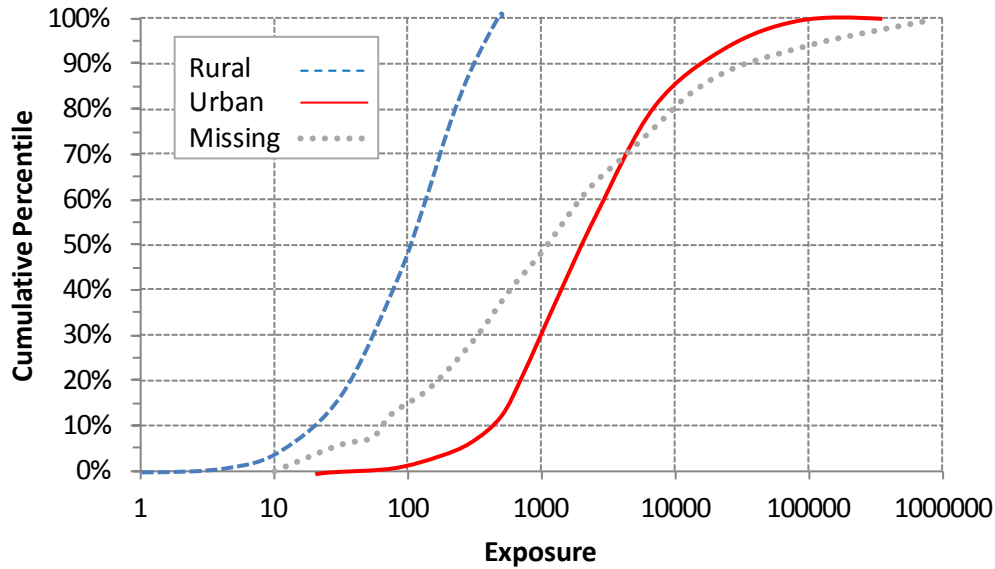
As previously discussed, a value of zero for daily trains indicates “less than daily,” and such a crossing may have high exposure due to high AADT. It is recommended use  $TotalTrn = 0.5$  in lieu of zero for exposure calculations. It is very important to consider the potential exposure of the few eligible crossings with less than daily trains because they qualified for the eligible set based on their crash histories. In the 2010 eligible set, there were only 7 crossings with less than daily trains, 1 in rural area (017790J) and the other in urban areas. Of these, 3 had AADTs greater than the urban 95% percentile. These 7 crossing IDs and their AADTs are listed below:

869868D	100
869873A	100
017727S	105
017790J	260
848968A	5,000
448851M	14,350
448826E	21,000

Exposure is considerably greater in urban than in rural areas, as suggested by the cumulative distribution depicted in [Figure 5-7](#) (note the logarithmic scale on the horizontal axis). The same two non-parametric tests of homogeneity between urban and rural exposures confirmed this at significance levels below 0.01 percent for both 2010 and 2011.

For missing urban/rural data, the tests could not reject the hypothesis “urban=missing” either with 2010 or with 2011 data. The hypothesis “rural=missing” was rejected by three of the four tests applied, but could not be rejected for one of them. Results are presented below [Figure 5-7](#).

For research purposes, exposure can be treated as urban when this information is unavailable. Nevertheless, this practice is not recommended. Rather, we recommend looking up the crossing location and populating the missing UrbanRural values.



**Figure 5-7 Exposure Cumulative Distribution (2010 Data)**

Null hypothesis:  $Exposure_{urban} = TotalTrn_{rural}$

2010 and 2011 results: reject the null hypothesis at P-values < 0.01% in both tests.

Null hypothesis:  $Exposure_{urban} = Exposure_{missing}$

2010 results: cannot reject the null hypothesis. P-values are 12% in the Kruskal-Wallis and 16% in the Median Test.

2011 results: cannot reject the null hypothesis. P-values are 99% and 47.7%, respectively for the Kruskal-Wallis and the Median tests.

Null hypothesis:  $Exposure_{rural} = Exposure_{missing}$

2010 results: reject the null hypothesis at P-values < 0.01% in the Kruskal-Wallis test and 4.5% in the Median Test.

2011 results: reject the null hypothesis at P-value < 0.01% in the Kruskal-Wallis test, but cannot reject with the Median Test (P-value = 6.8%)

Conclusions for research purposes:

- 1) Exposure (urban) > Exposure (rural)
- 2) Exposure (urban) = Exposure (missing)

*Warrant 1: Past Five-Year Crashes  $\geq 1$*

Crash history is an extremely important consideration, as crash prevention is the underlying reason for protective devices. The vast majority of methodologies found in the literature consider crash history in the decision-making process. Crash history is used in 23 states as one of the decision-making variables (ref. 6).

As discussed in the literature review, several studies indicate that vehicle-train crashes are more frequent in active than passive crossings and are primarily due to poor driving decisions such as driving around closed gates (refs. 14, 15, 22, 23, 24, 29). As a result, several jurisdictions

normally inspect crossings if there is more than one crash in a five-year period (e.g., ref. 10). A total of 177 crossings met Warrant 1. An initially proposed version of this warrant with a threshold of 2 or more crashes (21 crossings) was not approved. These results were prepared with 2011 data.

*Warrant 2: Trains per Day  $\geq$  95% Cumulative Percentiles for Urban and Rural Areas*

Train traffic volume appears in nearly all indices, rules and regulations investigated during this research. Average daily train traffic (ADTT) is used as a decision variable in 43 states (ref. 6). The 95% percentiles of the variable TotalTrn were 20 for urban areas and 29 for rural areas with 2011 data. A total of 141 crossings met this warrant, 87 rural and 54 urban.

*Warrant 3: School Buses per Day  $\geq$  94% Cumulative Percentile of the Subset of Eligible Crossings that Serve School Buses*

Daily school buses are a factor in 3 out of the 7 guidelines and methodologies discussed in the literature review, and were included in the current Texas Priority Index pursuant to a request by the Texas Legislature. Several states have similar concerns. For example, Rule 14-46.003 of the Florida Administrative code says gates should be installed when there are 10 or more school buses per day (ref. 7).

TxRAIL table GxFORM has the variable “SchoolBus” recording the number of daily school buses. It is zero for 75 percent of the crossings in both 2010 and 2011 eligible sets. Percentile calculations must be made after excluding all crossings that have SchoolBus=0, that is, percentiles consider only the crossings that actually have school buses. The 94% percentile value in 2011 was 10, and 45 crossings met this warrant.

*Warrant 4: Total Number of Tracks  $\geq$  2*

This warrant has a fixed threshold to reflect its intent, which is to flag crossings that require more time to clear, and/or where one train may hide another. Multiple tracks are a concern in several of the methodologies investigated in this project, including all those analyzed in this chapter. Total number of tracks is used as a hazard index variable in 22 out of 45 states (ref. 6).

The total number of tracks is calculated by adding up two variables in TxRAIL’s GxFORM table: MainTrack (number of main tracks) and OtherTrack (number of tracks other than mainline). In TxRAIL 2011, only 49 crossings (1.9 percent) did not have this information (the total number of tracks was zero), which makes this variable feasible as a warrant for Texas. With 2011 data, 526 crossings met this warrant. Considering the large number of crossings meeting this warrants, a threshold of 3 or more, which would warrant 165 crossings, was also proposed. The PMC preferred the threshold of 2.

*Warrant 5: Train Speed  $\geq$  49 mph and AADT  $\geq$  75% Cumulative Percentile in Urban/Rural Areas*

Train speed is present in several guidelines and methodologies discussed in the literature review. It is used as a hazard index variable in 13 out of 45 states (ref. 6). The underlying concern is that

accidents involving fast trains have more potential for injuries and fatalities. Train speed is recorded in TxRAIL GxFORM table as “MaxTTSpeed” variable.

Warrant 5 addresses the combination of fast trains with vehicular volumes at or above the 3<sup>rd</sup> quartile, two factors that when combined may increase the overall potential for fatalities and injuries. Warrant 5 logical statement is:

$$\begin{aligned} & \text{AADT cumulative percentile} \geq 75 \text{ percent (calculated separately by urban and rural using exact} \\ & \qquad \qquad \qquad \text{counts)} \\ & \qquad \qquad \qquad \text{and} \\ & \text{MaxTTSpeed} \geq 49\text{mph} \end{aligned}$$

FRA’s signal rules provide that, in the absence of a signal system, passenger trains are restricted to 59 mph and freight trains to 49 mph. If a basic signal system is in place, train speed may be increased to 79 mph (ref. 36). Table 5-12 presents the number of crossings meeting this warrant for different train speed values.

**Table 5-12 Crossings Meeting Warrant 5 by Train Speed Threshold (2011 Data)**

<b>Train Speed Threshold (mph)<sup>1</sup></b>	<b>Source</b>	<b>Crossings Meeting Warrant 5</b>
>65	95% percentile	17
>49	FRA: Freight, no signal	59
≥49	FRA: Freight, no signal	159
>59	FRA: Passenger, no signal	39
>79	FRA: Basic signal present	0
>78	FRA: Basic signal present	7

<sup>1</sup> VariableMAXTTSpeed from GxFORM table

Binary variable “SignalEqp” from GxFORM table is defined in the data dictionary as follows: “is track equipped with signals to control train operation?” Table 5-13 presents the cross-tabulation of the timetable speeds in urban and rural areas by this variable, which is the basis for FRA’s regulations. Table 5-13 statistics indicate that trains are typically slower in urban areas than in rural areas, and that most crossings do not have track signals (64.9 percent in rural areas and 88.7 percent in urban areas). Moreover, passenger trains are very rare. Therefore, the 49 mph threshold seems indicated for this warrant.

With 2011 data, 159 crossings met this warrant, 9 in urban areas and 50 in rural areas. Prevalence of rural crossings was expected because fast trains are considerably more frequent in rural areas.



**Table 5-13 Cross-Tabulation of Train Speed and Track Signals**

		MaxTTSpeed (Maximum Timetable Speed), mph														Total	
SignalEqp	Missing	<10 and ≤20	>10 and ≤30	35	40	45	49	50	55	59	60	65	70	75	79	Total	
Rural	MISSING	7 0.40%	8 0.50%	5 0.30%	0 0.00%	1 0.10%	13 0.80%	0 0.00%	9 0.50%	1 0.10%	9 0.50%	0 0.00%	3 0.20%	2 0.10%	0 0.00%	102 6.10%	
	NO	1 0.10%	96 5.70%	185 11.10%	38 2.30%	218 13.00%	3 0.20%	323 19.30%	6 0.40%	8 0.50%	67 4.00%	2 0.10%	14 0.80%	1 0.10%	5 0.30%	1086 64.90%	
	YES	0 0.00%	4 0.20%	9 0.50%	52 3.10%	30 1.80%	5 0.30%	28 1.70%	32 1.90%	90 5.40%	0 0.00%	137 8.20%	11 0.70%	57 3.40%	9 0.50%	16 1.00%	486 29.00%
	<b>Total</b>	8 0.50%	110 6.60%	199 11.90%	90 5.40%	260 15.50%	9 0.50%	364 21.70%	38 2.30%	107 6.40%	48 2.90%	213 12.70%	13 0.80%	74 4.40%	12 0.70%	21 1.30%	1674 100%
Urban	MISSING	9 1.00%	7 0.80%	4 0.40%	1 0.10%	1 0.10%	0 0.00%	4 0.40%	0 0.00%	0 0.00%	1 0.10%	0 0.00%	0 0.00%	0 0.00%	0 0.00%	9 3.10%	
	NO	6 0.60%	313 33.40%	248 13.60%	17 1.80%	34 3.60%	2 0.20%	47 5.00%	2 0.20%	7 0.80%	1 0.10%	21 2.20%	3 0.30%	0 0.00%	3 0.30%	6 0.60%	831 88.70%
	YES	0 0.00%	14 1.50%	9 1.00%	8 0.90%	11 1.20%	5 0.50%	2 0.20%	5 0.50%	4 0.40%	1 0.10%	5 0.50%	2 0.20%	1 0.10%	1 0.10%	0 0.00%	77 8.20%
	<b>Total</b>	15 1.60%	334 35.70%	261 14.60%	26 2.80%	46 4.90%	7 0.80%	50 5.30%	11 1.20%	11 1.20%	2 0.20%	27 2.90%	5 0.50%	1 0.10%	4 0.40%	15 1.60%	937 100%

*Warrant 6: Either AADT or Exposure  $\geq$  95% Percentile for Rural Areas and  $\geq$  90% Percentile for Urban Areas*

As previously discussed, exposure is the product of AADT and daily train traffic. Exposure is considered as a variable in Spanish, French, and FHWA guidelines. AADT is considered in all guidelines/methodologies for warrants found in the literature review. Daily train traffic is considered in the vast majority.

Several threshold levels were tested for this warrant. Formulations using the same threshold for urban and rural areas were unsatisfactory, resulting in unbalanced urban/rural proportions. The recommended thresholds of 90 percent urban and 95 percent rural resulted in a total of 249 crossings, 132 urban and 117 rural.

*Warrant 7: Average Number of Heavy Vehicles per Day  $\geq$  95% Percentile.*

While trucks considered in few hazard indices and other methodologies, “substantial number of trucks carrying hazardous materials (haz-mat)” qualifies a passive crossing for a possible upgrade in several jurisdictions, including those investigated in this chapter (refs. 7, 10, 11). TxRAIL does not specifically record haz-mat trucks, but it does record heavy vehicles as percentage of the AADT in GxFORM table variable “PercTrucks.” The 2011 eligible set (2663 crossings) has 112 missing values and 38 zeroes for “PercTrucks.” The variable is well populated and the warrant is feasible.

Although heavy vehicles are rarely considered by themselves in hazard indices and other methodologies, they can be a potential issue. Trucks take considerably longer than autos to clear the crossing. The literature presents instances of fatal accidents where trucks were hung up at rail crossings (ref. 14). In Texas, concern about heavy vehicles operating on crossings that may have profile irregularities increased as the number of fracking and other oil-related trucks increased, so the feasibility of a warrant that incorporates trucks and irregularities was investigated as documented below.

For both 2010 and 2011 data, the variable “DipHump” is missing for approximately 35 percent of the crossings. It has “yes” for 45 percent and “no” for 20 percent. The known values are split 70/30 percent into yes and no, respectively. Considering the predominance of crossings with dips and humps and the high percentage of missing data, a warrant considering only those that have a yes in conjunction with a high heavy vehicle percentile is likely leave out crossings that have irregularities and high truck volumes, but have DipHump=missing. Therefore, a truck warrant should either disregard the DipHump variable or include the missing values.

Table 5-14 shows the results of these two formulations for different truck percentile thresholds. Formulation 1 considers only the truck threshold; therefore, it captures crossings with no dips or humps. Formulation 2 considers the truck threshold only for crossings where DipHump is either 1 (yes) or missing. The analysis of results by DipHump values assumes that the 70/30 percent split into yes and no also holds for the missing values of DipHump. The rows with DipHump values of “No” and “Estimated no” indicates that formulation 1, which disregards the DipHump variable, flags a considerable number of crossings without irregularities.

**Table 5-14 Crossings Meeting Warrant 7 Variations (2011 Data)**

Warrant 7 Formulation	Dip/Hump	Cumulative Percentile Threshold for the Average Number of Daily Trucks	
		90%	95%
(1) Trucks/day $\geq$ percentile	N/A	263	128
Analysis of formulation 1 by DipHump values	Yes	106	38
	No	87	52
	Missing	70	38
	Estimated “no”	108	27
	Estimated “yes”	155	11
(2) (Trucks/day $\geq$ percentile) and (DipHump = 1 or DipHump=missing)	Yes	106	39
	Missing	70	39
	Total	176	78

Nevertheless, crossing profile irregularities are not the only issue that, when combined with heavy vehicles, can increase the potential for a hazardous situation on a passive crossing. Dips and humps may not even be the most important factor. The latest report on safety by TxDOT’s Rail Division indicated that 28 percent of all accidents in highway-railroad crossings between 2003 and 2007 involved large trucks. In passive crossings, this percentage is 31 percent (ref. 29). On the other hand, only 2 percent of all the statewide collisions reported that the highway user was “trapped on the crossing.” The final recommendation is to base the warrant only on the high truck volumes. Warrant 7 was met by 128 crossings.

*Warrant 8: Passenger Trains/Day  $\geq 1$*

A passenger train involves the lives of many human beings, thus significantly increasing the potential for injuries and fatalities in case of a collision. Variable “Pass\_cnt” in TxRAIL GxFORM table records the total number of passenger trains per day. Only 5 crossings met this warrant.

*Warrant 9: Presence of a Stopped Sight Distance Obstruction ( $0 < \text{StopObs1} < 8$  or  $0 < \text{StopObs2} < 8$ )*

A stopped sight distance obstruction poses an obvious risk in a passive crossing, and TxDOT has been addressing this problem. The latest safety report indicates that 98 percent of the collisions reported no obstructions (ref. 29). Nevertheless, the concern is important and a warrant for obstructions was developed.

Variables “StopObs1” and “StopObs2” from TxRAIL GxFORM table indicate the type of obstruction in each crossing approach. Values of 1 through 7 are considered relevant for the warranting procedures. There are 315 crossings with StopObs1=0 and 317 crossings with StopObs2=0 in TxRAIL 2011 passive crossing data; there is 1 crossing with both StopObs1

StopObs2 equal to 99. These were considered missing data. [Table 5-15](#) depicts the possible StopObs1 and StopObs2 values.

**Table 5-15 Variables StopObs1 and StopObs2 Values**

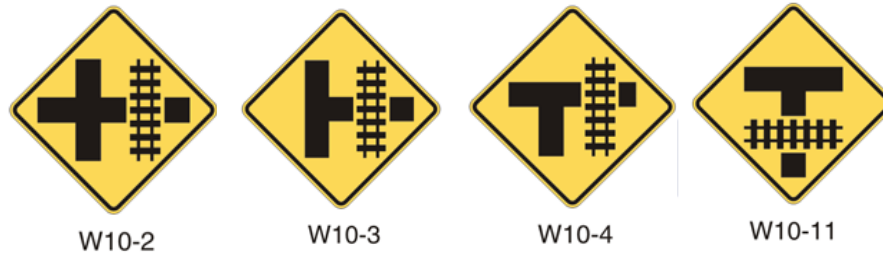
Value	View Obstructed by
1	Permanent Structure
2	Standing Railroad Equipment
3	Passing Train
4	Topography
5	Vegetation
6	Highway Vehicles
7	Other
8	View Not Obstructed
0 and 99	Missing information

With 2010 data, 1,663 crossings met this warrant, dropping to 1,435 in 2011. The PMC informed researchers that this variable is being updated. Actually, few passive crossings actually have sight distance obstructions in Texas. However, the PMC agreed that this warrant should be included, due to its importance for passive crossings. Given the fact that the data are outdated, all results discussed in this report exclude Warrant 9. This warrant should be turned off in TRIMS while the sight distance data are being updated.

*Warrant 10: Highway Parallel to and less than 75 ft from Tracks when Other Factors Are Present*

Warrant 10 addresses a highway parallel to and less than 75ft from the tracks (but not embedded in the median), in conjunction with highway speed limit greater than 30 mph, and either one of the following factors also present: exposure percentile  $\geq 75$  percent (urban and rural separately) or school bus percentile  $\geq 50$  percent or heavy vehicles percentile  $\geq 75$  percent.

[Figure 5-8](#) shows the advance warning signs recommended for low-volume roads to warn motorists making a turn that the highway is parallel to a railroad and that they will encounter a railroad crossing upon making the indicated turning movement. These signs clearly illustrate the situation covered by this warrant. The Texas Manual of Uniform Traffic Control Devices (MUTCD) recommends signs W10-2, 3, and 4. Some states recommend variations such as W10-11 in addition to the others (ref. 5).



**Figure 5-8 MUTCD Parallel Highway Advance Warning Signs**

This type of crossing geometry may cause problems even when properly signalized. The FL-DOT guidelines recommend upgrading from passive to active when there are “heavy turning movements from a parallel highway onto the crossing” (ref. 7). TxRAIL does not include intersection turning movement counts, but it includes other variables that increase the potential for an incident in a parallel highway. Large vehicles may have difficulty completing the turning movement before the crossing stop line when the highway is too close to the tracks. Moreover, drivers do not always pay attention to advance warning signs, especially when driving relatively fast, or when heavy vehicles may block the driver’s line of sight, or when a nearby intersection competes with the sign for the driver’s attention. TxRAIL includes all those variables and they were all investigated to develop this warrant.

TxRAIL variable “HwyNear” (GxFORM table) captures the parallel highway geometry. Its meaning is stated as follows in the data dictionary: “If the crossing highway is intersected by another highway, what is the distance from the crossing to the intersection.” HwyNear values (1 to 4) indicate classes of distances. The list below indicates the meaning of HwyNear values and the number of crossings with each value in the 2,663 eligible set used to illustrate the results. Zeroes and blanks were assumed to mean no parallel highway.

HwyNear = 1.....	Less than 75 ft.....	1,113 crossings
HwyNear = 2.....	75 to 150 ft.....	1,077
HwyNear = 3.....	151 to 200 ft.....	4 crossings
HwyNear = 4.....	Over 200 ft.....	462 crossings
Other values .....	Not Available .....	7 crossings

Binary variable “DownStreet” in GxFORM table describes tracks are embedded in the highway. Since it seems unlikely that a motorist would fail to notice the parallel railroad in this case, only crossings with DownStreet=2 (no) are included in this warrant. There are only 56 crossings with missing DownStreet values in TxRAIL 2011 passive crossing list, so the variable is populated and can be meaningfully included.

Not all crossings with this geometry are automatic candidates for upgrades. The warrant must also consider additional conditions that increase potential risk factors for a parallel highway too close to the tracks. As a matter of fact, over 1,000 crossings would meet a warrant based solely on the parallel highway variables HwyNear=1 and DownStreet=2.

Table 5-16 shows the variables that were considered good candidates for inclusion in Warrant 10 and analyzed. Variable names in *boldface italics* indicate variables created with calculations using TxRAIL variables.

Advance warning signs were could not be included since variables AdvWarnSgn1 and AdvWarnSgn2 do not seem fully populated. These variables (one for each approach) take the values of 1 or 2 (respectively, yes and no), but approximately 80 percent of their values were either zero or missing. A consultation with the PMC indicated that absence of warning signs is not necessarily considered an upgrade priority and may be addressed separately, while a crossing with a parallel highway may need an upgrade regardless of the presence of advance warning signs. Furthermore, the signalization is also undergoing updates due to new MUTCD requirements.

**Table 5-16 Candidate Variables Analyzed for Warrant 10**

<b>Created Variables/ Notes</b>	<b>TxRAIL Variables</b>	<b>Table</b>
Daily school buses	SchoolBus	GxFORM
Nearby intersection	NearbyInt1 NearbyInt2	tblCONTROLS
Warning signs present	AdvWarnSgn1 AdvWarnSgn2	tblCONTROLS
Default values when absent: 30mph urban and 55mph rural	SpeedLimit SpeedLimit2	GxFORM
<i><b>AADT</b></i>	PAADT if present, else AADT*	GxFORM
<i><b>Heavy_vehicles</b></i> =[PercTruck* <i><b>AADT</b></i> ] / 100	PercTruck	GxFORM
<i><b>Exposure</b></i> = <i><b>AADT</b></i> *TotalTrn	TotalTrn	GxFORM

\*This investigation used conservative data, taking the maximum of AADT and PAADT.

School buses and trucks may have problems completing a turning movement before the crossing on the type of geometry represented by “HwyNear=1.”

There were 779 crossings with HwyNear=1 and a nearby intersection on either approach. Using a nearby intersection as an additional warrant condition would make 595 to 625 crossings meet Warrant 10, depending on the other variables’ thresholds. It was decided to exclude presence of a nearby intersection, considering that it is not possible to determine from the data if its location may really increase the potential risk.

Highway vehicular speed is considered as a variable in 22 out of 45 states in their hazard index formulas and in several guidelines/methodologies discussed in the literature review. TxRAIL GxFORM table stores it for both crossing approaches in variables “SpeedLimit” and “SpeedLimit2.” The 2011 eligible set (2,663 crossings) had zeroes on both directions for 1,031

crossings. This issue was discussed with the PMC, and it was decided to use default values of 30 mph for urban areas and 55 mph for rural areas.

Fifty-seven combinations of threshold values and logical statements using the variables listed in [Table 5-16](#) were analyzed. [Table 5-17](#) illustrates this analysis by presenting the four best formulations found for this warrant.

**Table 5-17 Examples of Warrant 10 Investigation**

Formulation	Attribute	Percentile Threshold (≥)	Threshold Values*	Crossings Meeting Warrant	Total Warranted Set
1	Exposure	75%	4960 urban 1200 rural	105	650
	School buses	75%	4		
	Trucks	75%	12		
2	Exposure	75%	4960 urban 1200 rural	145	689
	School buses	50% (median)	2		
	Trucks	75%	12		
3	Exposure	75%	4960 urban 1200 rural	167	711
	School buses	50%	2		
	Trucks	50%	4		
4	Exposure	50%	2188 urban 595 rural	210	750
	School buses	50%	2		
	Trucks	50%	4		

\* TxRAIL2011 data

Formulation 2 (highlighted in blue in [Table 5-17](#)) is the final recommendation. Warrant 10 logical statement is:

(HwyNear=1) and (DownStreet=2) and (SpLim>30)  
and  
[(*exposure\_pct*≥75%) or (*schbuspct*≥50%) or (*truckpct*≥75%)]

Where:

HwyNear and DownStreet come directly from TxRAIL’s GxFORM table.

SpLim is the maximum of Speedlimit and SpeedLimit2 (maximum of both traffic directions). Missing values are assigned the default values listed in [Table 5-16](#).

*exposure\_pct* is the cumulative percentile of the product of GxFORM variable TotalTrn and *AADT*. Percentiles are calculated separately by GxFORM variable UrbanRural. TxDOT uses variable PAADT in lieu of variable AADT when available. This research used the maximum of

the two in order to be conservative. This research used the maximum of both in order to be conservative; the impact on the final results is very small.

*schbuspct* is the cumulative percentile of the number of school buses for all crossings that have school buses (the percentile calculation does not include the zeroes).

*truckpct* is the cumulative percentile of the product of GxFORM variable PercTruck divided by 100, and *AADT*. TxDOT uses variable PAADT in lieu of variable AADT when available.

## Summary of Results, Conclusions and Recommendations

The warranted set eliminates includes all passive crossings with characteristics that may increase the potential crash risk. [Table 5-18](#) summarizes the results of each step of the qualification and warranting procedure. [Table 5-19](#), located in the last page of this chapter, shows the approved warrants and the detailed results.

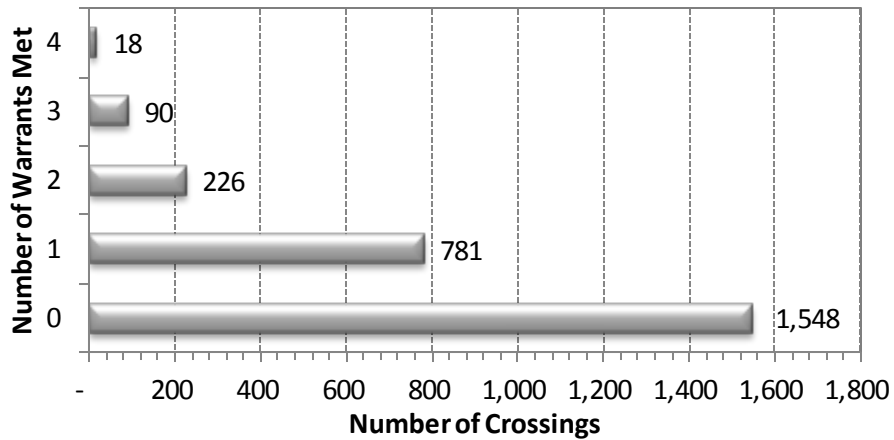
**Table 5-18 Summary of the Warranting Procedure**

<i>Filtering Criteria</i>	<i>Passive crossings in filtered list</i>	<i>Percent</i>
1) Open, public passive crossings	3,756	100%
2) Eliminate all crossings that serve less than 2 daily trains unless they had an accident in the past five years	2,715	72%
3) Apply the 10 non-qualification criteria and remove the non-qualifiers	2,663	71%
4) Apply the 10 warrants and select crossings meeting at least one	1,115	30%

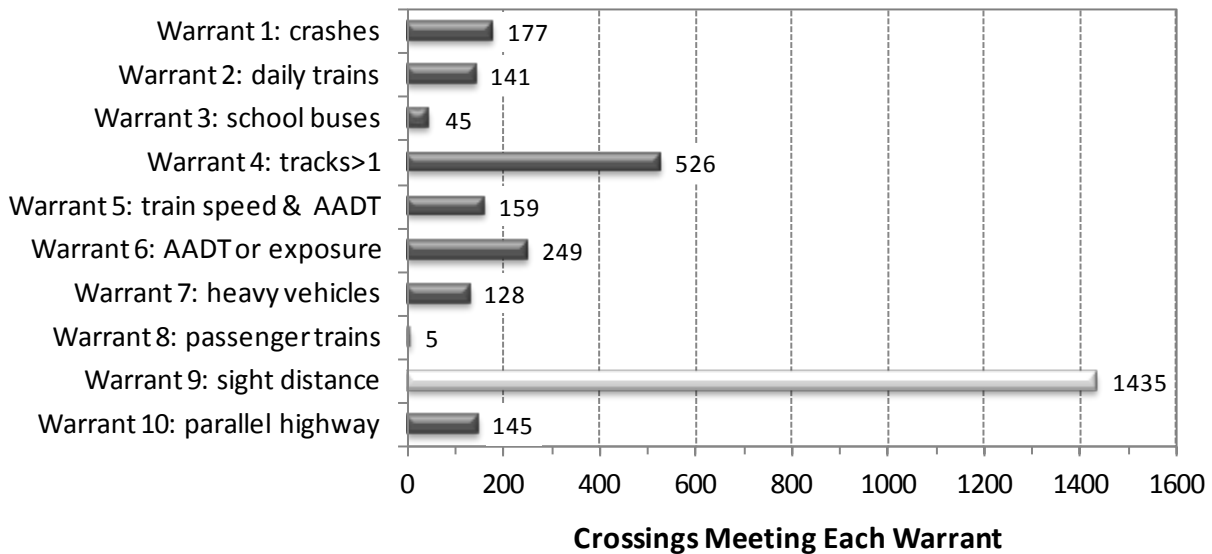
[Figure 5-9](#) shows the number of crossings by number of warrants met. The maximum number of warrants met was 4 and 18 crossings met 4 warrants. TxRAIL 2011 data were used, and Warrant 9, stopped sight distance obstruction, was not included in this count because most data are undergoing updates and the results would be extremely biased. [Figure 5-10](#) shows the number of crossings meeting each warrant. This figure includes a bar for Warrant 9 in a lighter shade, to illustrate the data issue. Please note that the sum of these numbers is greater than the size of the warranted set because 334 crossings met multiple warrants.

As mentioned earlier, TxDOT spends about \$15 million per year to update railroad crossings. Considering an average cost of \$0.2 million per crossing for upgrade from passive to gates, this considerably limits the number of crossings that TxDOT can improve each year. For example, TxDOT would only be able to install gates in at most 75 crossings per year. Since over 1000 crossings satisfied the warrants (2011 data), there is a clear need for a prioritization procedure.





**Figure 5-9 Number of Crossings Meeting Warrants**



**Figure 5-10 Number of Crossings Meeting Each Warrant**

The revised Texas Priority Index discussed in [Chapter 4](#) broadened the scope of the existing index. It considers relevant variables and is based on an updated crash prediction model. However, it is impossible to develop an index based on crash prediction that does not place most low-volume crossings at the bottom of the list. Exposure is between hundreds and thousands of times greater in active than passive crossings while the other variables in the crash prediction equation are either categorical or have similar orders of magnitudes for passives and actives. Therefore, any prioritization method relying on the revised Texas Priority Index (TPI) will continue to place most passive crossings at the bottom of the list and defeat the purpose of this project, which is to develop a prioritization method that does not penalize the passive crossings. The next chapter discusses the Texas Passive Crossings Index, developed in this project to properly prioritize the warranted set.

**Table 5-19 Warrants and Detailed Results**

Warrants	Thresholds			TxRAIL 2011 Data Crossings Meeting Each Warrant	Variable Name	TxRAIL Table
	Fixed	Percentile	TxRAIL11 Perc. Value			
	1 Past 5 year crashes	≥1				
2 Trains / day		≥95%	29	141	TotalTrn	GxForm
		≥95%	20	87		
		≥94%	10	54		
3 School buses/day				45	SchoolBus	GxForm
4 Multiple tracks	≥2			526	(MainTrack+OtherTrack)	GxForm
5 Train speed and AADT				159		GxForm
Train speed and	≥49			1011	MaxTTSpeed and	
AADT percentile		≥75%	150	426	[max(AADT,PAADT)]	
		≥75%	1310	245		
6 AADT or Exposure			AADT	249		GxForm
		≥95%	730		[max(AADT,PAADT)]	
		≥90%	3390		AADT or exposure, rural: 117	
		≥95%	3480		AADT or exposure, urban: 132	
		≥90%	16200		[(max(AADT,PAADT))*TotalTrn]	
7 Heavy vehicles		≥95%	111	128	[(max(AADT,PAADT))*PercTruck/100]	GxForm
8 At least 1 passenger train	≥1			5	Pass_cnt	GxForm
9 SSD obstruction				1435	[(StopObs1 > 0 and StopObs1 <8] or	GxForm
10 Highway parallel to tracks, distance<75ft				145	[(StopObs2 > 0 and StopObs2 <8]	GxForm
Hwy Near and	1			1113	Hwy Near=1 and	
DownStreet and	2			2496	DownStreet=2 and	
Speed Limit and	>30			859	max(SpeedLimit,SpeedLimit2)>30 and	
[Exposure or		≥75%	1200	430	[(max(AADT,PAADT))*TotalTrn] or	
		≥75%	4960	245		
School bus or		≥50%	2	609	SchoolBus or	
Trucks/day]		≥75%	12	642	[(max(AADT,PAADT))*PercTruck/100]	
<b>TOTAL WARRANTED CROSSINGS</b>				<b>1115</b>		



## **CHAPTER 6**

### **TEXAS PASSIVE CROSSINGS INDEX**

#### **Background and Objective**

The warrants documented in [Chapter 5](#) ensure that all passive crossings with potential risk factors are considered, resulting in a rather large warranted set (1,115 crossings with 2011 data) and in the need to prioritize passive crossings. The analyses of existing priority, hazard, and crash prediction indices carried out during this project consistently resulted in the following conclusions:

- All indices must consider annual average daily traffic (AADT), since the crash probability increases with exposure (the product of AADT and train traffic).
- For the most part, AADT is considerably high in active crossings and rather low in passive ones. The difference in order of magnitude ranges between hundreds and thousands.
- The indices must also consider crash history and many of them are based on crash predictions, including the revised Texas Priority Index (TPI) documented in [Chapter 4](#).
- Historically, Texas active crossings have between 3 and 4 times the crash/crossing rate of passive crossings (five-year crashes). Moreover, the majority of multiple crashes occurred in active crossings (0.8 percent of the passives and 1.6 percent of the actives, i.e., twice as many).
- All other relevant variables that are not categorical have approximately the same order of magnitude for passive and active crossings.
- These discrepancies in order of magnitude make it extremely difficult if not altogether impossible to develop a statistical model capable of properly considering AADT and assigning a high priority to passive (low-volume) crossings that have risk factors.
- For these reasons, a significant number of agencies base their decisions either on a combination of warrants/rules and a priority index (such as Florida and Illinois), or only on warrants/rules (such as Idaho and many European countries). This was discussed in [Chapter 5](#) and reinforces the need for warrants.

Pursuant to these findings, the researchers develop the proposed Texas Passive Crossings Index (TPCI), which was necessary to develop a new prioritization methodology capable of properly prioritizing passive crossings with potential risk but low AADT.

#### **Objectives of a Passive Crossings Index**

The disproportionate influence of AADT on the crossing prioritization would also happen in a passive-only index based on statistical models, as demonstrated by the AADT quantiles of the 2011 warranted set depicted in [Table 6-1](#). The difference in order of AADT magnitude between the top 5 percent and the bottom 5 percent still is in the thousands.

**Table 6-1 AADT Quantiles in the Warranted Set**

<b>Quantile</b>	<b>Estimate</b>
<b>100% Max</b>	<b>35950</b>
<b>99%</b>	<b>15800</b>
<b>95%</b>	<b>5944</b>
<b>90%</b>	<b>3320</b>
<b>75% Q3</b>	<b>820</b>
<b>50% Median</b>	<b>260</b>
<b>25% Q1</b>	<b>85</b>
<b>10%</b>	<b>20</b>
<b>5%</b>	<b>10</b>
<b>1%</b>	<b>10</b>
<b>0% Min</b>	<b>0</b>

Another concern is the absence of an index when one or more component variables have missing values. There are 83 warranted crossings with missing values of one or more priority index variables. Of these, 33 met multiple warrants and 4 had multiple crashes. Considering that TxDOT normally inspects about 100 passive crossings per year, the inability to evaluate these 33 crossings due to lack of a variable is not desirable. A useful index to rank the passive crossings should have the following characteristics:

- Have the ability to assign high priorities to passive crossings that have low AADTs when other risk factors are present.
- Have an estimated value even when some of its component variables are missing.
- Reflect the relative importance of each variable on the overall risk.

Utility Theory, a Decision Theory framework widely used in engineering, behavioral sciences, marketing, and economy, has these capabilities (refs. 1, 9). It has been in use for decades in many locations and jurisdictions, including at TxDOT. A 1989 bridge management system for TxDOT was based on this concept (ref. 37). TxDOT's Pavement Management System evaluates pavements based on two indices, the Distress Score and the Condition Score, based on Utility Theory (refs. 26, 38).

### **Utility Theory Concepts and Their Application to Highway-Railroad Crossings**

Utility Theory prioritizes alternatives based on factors (termed *attributes*) known to influence the outcome, assuming that all decisions are made based on the "Utility Maximization Principle": the greater the utility of an alternative, the greater its influence on the outcome and the greater its priority.

The utility of an alternative is a number between 0 and 100 percent that represents the alternative's potential for the outcome behind the evaluation. Each alternative is characterized by a series of relevant attributes, and each attribute has its own utility curve. An attribute's utility curve represents its individual influence on the outcome as a function of its possible values. The alternative's total utility is the weighted average of its attributes' individual utilities. Weights

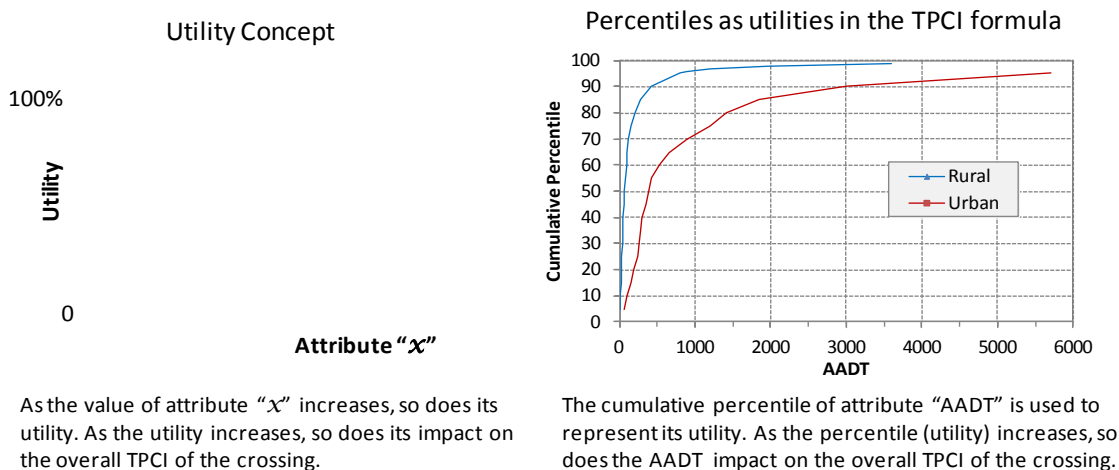
represent the attributes' relative importance. Applying these concepts to the highway-rail crossings prioritization:

- The *outcome* motivating the evaluation is the crash potential.
- The *alternatives* are the crossings.
- Each crossing's *utility* is its Texas Passive Crossings Index (TPCI).
- The TPCI *attributes* are the TxRAIL variables selected as relevant.
- Each variable *utility* is its cumulative percentile calculated over the passive crossings eligible set.

Figure 6-1 depicts the theoretical concept of an attribute's utility on the left side, and on the right side a corresponding TPCI attribute, in this case the AADT cumulative percentiles. Cumulative percentiles have the same mathematical behavior as utility functions: they are both continuous functions with a maximum value of 100, positive first derivatives, negative second derivatives, and passing through the origin. Mathematically both represent the same idea: the greater the attribute (variable) value, the greater its impact on the priority.

A management system that uses cumulative percentiles to represent attributes' utilities and the weighted average formula to rank priorities was first implemented at TxDOT in 1990 (ref. 37). The index is depicted in Equation 6-1. This formulation has the following advantages:

- The percentiles self-adjust every time they are recalculated for new data. Therefore, the evaluation always reflects the latest data.



**Figure 6-1 Concept of Attribute Utility**

- Cumulative percentiles do not bias the index toward prioritizing large values of any given variable. The right plot of Figure 6-1 illustrates this property when there are differences between urban and rural areas. For example, a rural crossing with AADT of 250 and an

urban crossing with an AADT of 1,500 are at the same 80 percentile, so the index will not prioritize urban crossings over rural crossings just because of higher AADT.

- Cumulative percentiles are not estimates based on models. They are accurate counts and represent each crossing’s relative position with respect to all others in the most current data.
- Since the index is the weighted average of the available data, crossings with some missing data still get evaluated.
- If desired, the index can be coded with an option to override the default weights developed in this research, allowing the user to emphasize one or more issues over the others on any given year to reflect funding priorities or policy issues.
- Conversely, if the manager knows that an issue has already been resolved for most crossings but the database has not yet been updated, s/he can assign a very low weight (or a weight of zero) to that variable for that particular analysis. The ongoing sight-distance update discussed in [Chapter 5](#) is an example of the practicality of [Equation 6-1](#) formulation.

$$TPCI = \frac{\sum_{i=1}^n U_i w_i}{\sum_{i=1}^n w_i} \quad [6-1]$$

Where:

TPCI = Texas Passive Crossings Index.

n = number of attributes (TxRAIL variables) used to calculate the TPCI.

$U_i$  = utility of the  $i^{\text{th}}$  attribute, estimated by its cumulative percentile as explained later.

$w_i$  = weight of the  $i^{\text{th}}$  attribute.

## TPCI Formulation

### Overview

TPCI development required selecting the attributes (TxRAIL variables) and developing the weights in [Equation 6-1](#). [Table 6-2](#) shows the TPCI final choice of variables and final weights. All 13 variables are available in TxRAIL’s GxFORM and tblControls tables.

The weights depicted in [Table 6-2](#) are based on a survey conducted during the June 2011 workshop conducted in this project (see [Appendix 3](#)). The researchers asked the participants to rate 22 variables in terms of their importance in the decision to upgrade a crossing, using the following scale:

0 Not necessary

1 May consider

- 2 Secondary importance
- 3 Important
- 4 Very important
- 5 Crucial

Four members responded. Their answers were normalized as explained later in this chapter to arrive at the weights shown in [Table 6-2](#). The answers were also used (in conjunction with the analyses discussed in the previous chapters) as guidance to select the variables for the warrants, for the TPCI, and for the revised TPI.

**Table 6-2 TPCI Variables and Weights**

<i>Attribute</i>	<i>Normalized Weight</i>
Five-year crashes	5.0000
Daily trains	4.7780
Daily school buses	4.7780
Number of tracks	3.8568
Train speed	3.8568
AADT	3.2922
Nearby traffic signal	3.0160
Sight distance	3.0160
Trucks per day	1.9300
Nearby intersection	1.8038
Highway speed limit	1.7132
Approach angle	1.5016
Dip/hump	1.0000

### Attribute Utilities and Percentiles

#### *Definitions for Numeric and Categorical Variables*

An attribute (variable) utility represents its contribution to the overall index. If a crossing does not have an attribute, the utility is set to zero. For example, if a crossing had no crashes, the crash utility is set to zero. For those that have crashes, the utility is the cumulative percentile calculated over the values that are greater than zero.

The correct and incorrect methods to calculate percentiles were discussed in detail in [Chapter 5](#). The correct method is:

- Count the number of occurrences of each value.
- Calculate the cumulative count and the grand total.



- Cumulative percentiles are the cumulative occurrences of each value divided by the grand total.

As explained in detail in [Chapter 5](#), percentile calculations using built-in functions that divide the data into equal-size bins may result in the same percentile being assigned to different variable values. The TPCI requires a unique value reflecting the exact count of each occurrence.

Some of the TPCI variables are categorical, so their utilities represent their full contribution if present (U=100 percent) and no contribution if absent (U=0). Examples: sight distance obstructions and signalized intersections in the vicinity.

All examples presented in this chapter use data from TxRAIL 2011 and crash data for the 2007 to 2011 period. The TPCI was implemented only for the 2,663 passive crossings in the eligible set obtained after eliminating non-qualifiers with the criteria discussed in [Chapter 5](#).

#### *Crashes in the Past Five Years*

Crash utilities are the cumulative percentiles calculated only for crossings that have crashes and set to zero if there are no crashes. [Table 6-3](#) shows the results.

**Table 6-3 Five-Year Crashes Utilities/Cumulative Percentiles**

<i>Five-Year Crashes</i>	<i>Occurrences</i>	<i>Cumulative Percentile (%)</i>
0	2,486	0.0
1	156	88.1
2	17	97.7
3	3	99.4
4	1	100.0

#### *Total Trains per Day*

Train traffic utilities are the cumulative percentiles calculated separately for urban and rural areas. Train traffic percentiles are also used in the warrants and were discussed in detail in [Chapter 5](#) under the section “Total Daily Trains.” Zero is a valid value, since it represents less than daily trains. Crossings with less than daily trains are eligible for the warranting procedure only if they had accidents; there were 10 in the data used for the examples. [Table 6-4](#) shows the results.

**Table 6-4 Total Trains per Day Utilities/Cumulative Percentiles**

<i>Variable TotalTrn Values</i>	<i>Occurrences</i>	<i>Cumulative Occurrences</i>	<i>Cumulative Percentile (%)</i>
0	10	10	0.38
1	5	15	0.56
2	646	661	24.82

<i>Variable TotalTrn Values</i>	<i>Occurrences</i>	<i>Cumulative Occurrences</i>	<i>Cumulative Percentile (%)</i>
3	101	762	28.61
4	315	1077	40.44
5	103	1180	44.31
6	194	1374	51.60
7	106	1480	55.58
8	261	1741	65.38
9	36	1777	66.73
10	151	1928	72.40
11	30	1958	73.53
12	118	2076	77.96
13	21	2097	78.75
14	63	2160	81.11
15	73	2233	83.85
16	79	2312	86.82
17	31	2343	87.98
18	41	2384	89.52
19	4	2388	89.67
20	79	2467	92.64
21	3	2470	92.75
22	19	2489	93.47
23	12	2501	93.92
24	31	2532	95.08
25	9	2541	95.42
26	11	2552	95.83
27	1	2553	95.87
28	4	2557	96.02
29	42	2599	97.60
30	38	2637	99.02
31	8	2645	99.32
32	1	2646	99.36
33	1	2647	99.40
34	2	2649	99.47
37	2	2651	99.55
38	4	2655	99.70
50	1	2656	99.74
52	4	2660	99.89

<i>Variable TotalTrn Values</i>	<i>Occurrences</i>	<i>Cumulative Occurrences</i>	<i>Cumulative Percentile (%)</i>
62	1	2661	99.92
70	1	2662	99.96
82	1	2663	100.00

### *School Buses per Day*

School bus utilities are cumulative percentiles calculated only for crossings that have school buses set to zero for those without school buses. [Table 6-5](#) shows the results.

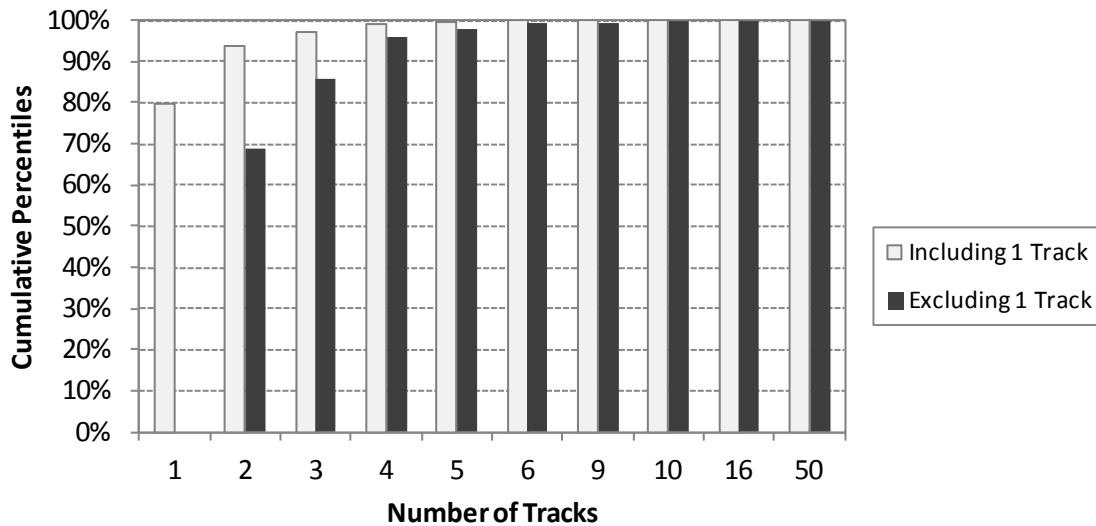
**Table 6-5 School Buses per Day Utilities/Cumulative Percentiles**

<i>Variable SchoolBus Values</i>	<i>Occurrences</i>	<i>Cumulative Occurrences</i>	<i>Cumulative Percentile (%)</i>
0	2007	2007	0
1	47	47	7.16
2	307	354	53.96
3	33	387	58.99
4	148	535	81.55
5	10	545	83.08
6	35	580	88.41
7	6	586	89.33
8	23	609	92.84
9	2	611	93.14
10	6	617	94.05
11	2	619	94.36
12	6	625	95.27
13	1	626	95.43
14	1	627	95.58
15	1	628	95.73
16	5	633	96.49
18	2	635	96.80
20	6	641	97.71
22	2	643	98.02
24	1	644	98.17
25	2	646	98.48
26	2	648	98.78

<i>Variable SchoolBus Values</i>	<i>Occurrences</i>	<i>Cumulative Occurrences</i>	<i>Cumulative Percentile (%)</i>
30	1	649	98.93
32	2	651	99.24
40	3	654	99.70
44	1	655	99.85
176	1	656	100.00

*Total Number of Tracks*

As depicted in Figure 6-2 light-colored bars, the total number of tracks is predominantly 1 (nearly 80 percent of the crossings). Since every highway-rail crossing has at least one track, the contribution of this minimum value to the TPCI should be zero rather than a high percentile. Percentiles calculated after removing crossings with only one track are also depicted in Figure 6-2. In the data used for this example, 53 crossings had zero tracks. Zeroes are treated as missing information and removed from the percentile calculations.



**Figure 6-2 Total Number of Tracks Cumulative Percentiles**

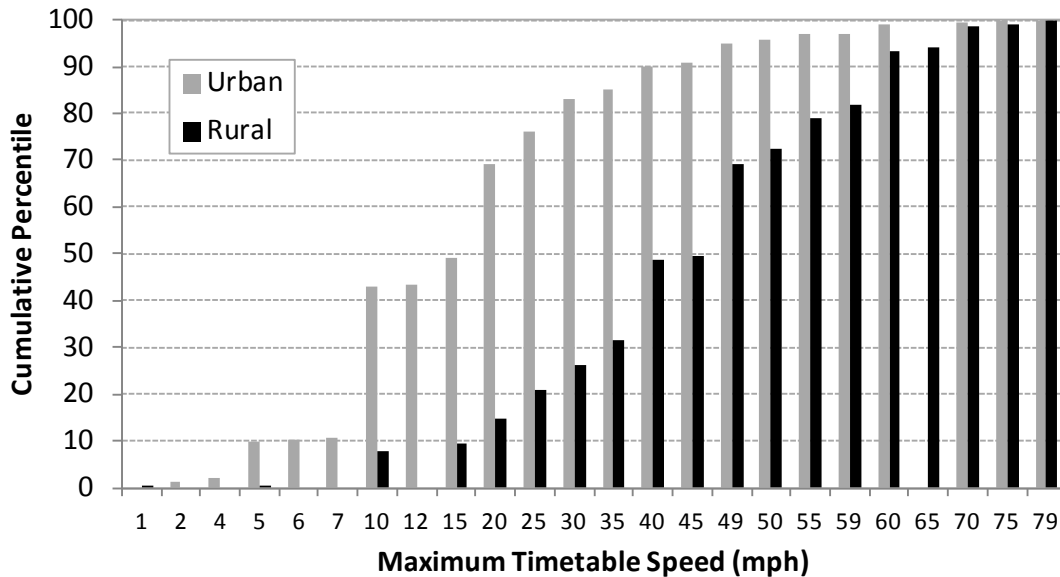
A sensitivity analysis of the percentile values calculated for tracks>1 indicated that this variable behaves as categorical; its recommended utility values are as follows:

- 1 track.....0%
- 2 tracks .....50%
- 3 or more tracks .....100%

### *Train Speed*

This variable is MaxTTSpeed from TxRAIL GxFORM table. Cumulative percentiles appear very different for urban and rural areas, as depicted in [Figure 6-3](#). Two non-parametric tests of homogeneity, the Kruskal-Wallis and the Median tests, confirmed this fact by rejecting the null hypothesis of homogeneity among urban and rural train speeds at significance levels below 0.01 percent in both tests (for both 2010 and 2011 data).

Utilities are the cumulative percentiles calculated separately for urban and rural areas in order to give both areas equal importance. Zeroes are regarded as missing and removed from the calculation.



**Figure 6-3 Utilities/Cumulative Percentiles of Train Speed**

### *Annual Average Daily Traffic (AADT)*

AADT percentiles are also used in the warrants. AADT utilities are the cumulative percentiles calculated separately for urban/rural areas as discussed in [chapter 5](#). Zeroes are considered missing data and removed.

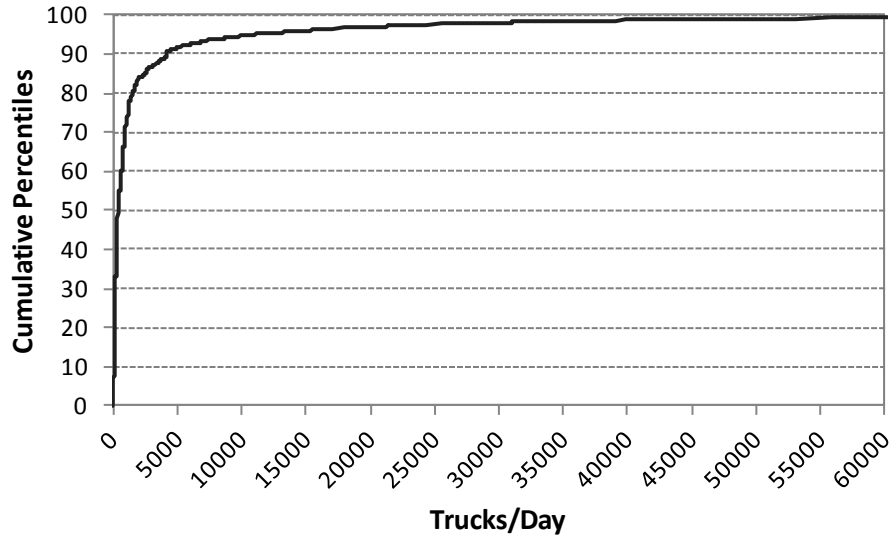
### *Heavy Vehicles per Day*

This variable is also used in the warrants. It is obtained by multiplying AADT by variable PercTrucks (GxFORM table). Utilities are cumulative percentiles calculated only for crossings that have truck traffic and set to zero for those that do not have trucks (PercTrucks=0). [Figure 6-4](#) shows the results.

### *Highway Speed Limit*

As discussed in [Chapters 4 and 5](#), missing values receive the default values of 30 mph for urban areas and 55 mph for rural areas. The abundance of missing values combined with the

preponderance of 30–35 mph speed limits in Texas urban areas and 55 mph or higher speeds in rural areas would place nearly all crossings at very high highway speed percentiles, precluding their meaningful use as utilities in the TPCI formula. Moreover, the speed limit does not necessarily represent the vehicles’ actual speeds when approaching a rail crossing.



**Figure 6-4 Cumulative Percentiles/Utilities of Heavy Vehicles per Day**

Highway speed limit was considered in conjunction with a nearby intersection, since its presence influences the driver actual speed. Speed limit utilities values are set as follows:

- In urban areas, set to 100 percent if the speed limit is greater than 35 mph and there is no nearby intersection. Otherwise, set to zero.
- In rural areas, set to 100 percent if the speed limit is greater than 45 mph and there is no nearby intersection. Otherwise, set to zero.

*Nearby Intersection and Nearby Traffic Signal*

TxRAIL table tblControls records these two TPCI attributes for both approaches as binary variables that take the values of 1 if present, 2 if not. The variables are NearbyInt1, NearbyInt2, NearSignalized1, and NearSignalized2. These two variables are important, since about 80 percent of the highway-rail collisions occur near intersections (ref. 29). A signalized intersection near a passive crossing further increases the potential for a crash due to the possibility of red light queues spilling back onto the tracks; hence its weight in the TPCI formula is higher than that for non-signalized intersections (see Table 6-2 and Table 6-10).

A nearby traffic signal also appears in TxRAIL as a nearby intersection; since both variables are part of the index, it is important to consider a signalized intersection only once. Table 6-6 (valid for both approaches) shows how to assign the utilities.

**Table 6-6 Utilities for Nearby Intersections and Nearby Signals**

<i>NearSignalized</i>	<i>NearbyInt</i>	
	<i>1</i>	<i>2</i>
<i>1</i>	NearSignalized=100% NearbyInt=0%	n/a
<i>2</i>	NearSignalized=0% NearbyInt=100%	NearSignalized=0% NearbyInt=0%

*Approach Angle*

The smaller the angle between railroad and highway, the less visibility. TxRAIL records variable CrossAngle in three categorical values, by range. The angle ranges, variable values, and utilities are listed below.

0 <sup>0</sup> to 29 <sup>0</sup> .....	CrossAngle = 1 .....	100%
0 <sup>0</sup> to 59 <sup>0</sup> .....	CrossAngle = 2 .....	50%
60 <sup>0</sup> to 90 <sup>0</sup> .....	CrossAngle = 3 .....	0%

*Profile Irregularities (Dips and Humps)*

In TxRAIL this is the binary variable DipHump in GxFORM table: 1 means presence and 2 means absence. Utilities for TPCI calculations are also binary, 100 percent if present and 0 if absent.

*Sight Distance Obstruction*

StopObs1 and StopObs2 are categorical variables indicating the type of obstruction (values 1 through 7) or its absence (value of 8), on each approach. Other values should be treated as missing data. Utilities are binary, 100 percent if present on either approach, 0 if absent on both approaches. As discussed in [Chapter 5](#), this variable is undergoing updates and was not included in the calculations presented in this chapter.

**TPCI Variables’ Weights**

As previously mentioned, a survey of 22 variables was distributed during the June 2011 workshop (see [Appendix 3](#)). [Table 6-7](#) shows the four original responses received. The two variables in the last two rows, in light font, are not present in TxRAIL but were included in the survey pursuant to literature review findings.

**Table 6-7 Original Survey Scores**

<i>Variable</i>	<i>Response 1</i>	<i>Response 2</i>	<i>Response 3</i>	<i>Response 4</i>	<i>Average</i>
Number of trains	5	5	4	4	4.50
School buses	5	5	3	4	4.25
5-yr crashes > 2	4	5	3	5	4.25
5-yr crashes > 1	4	3	1	3	2.75
5-yr crashes > 0	4	2	0	1	1.75
AADT/traffic volume	5	4	4	3	4.00
Nearby traffic signal	4	4	3	4	3.75
Number of tracks	5	4	2	4	3.75
Train speed	5	4	2	4	3.75
Sight distance	4	4	2	4	3.50
Approach angle	4	3	2	3	3.00
Number of highway lanes	4	1	2	4	2.75
Urban/rural	5	3	0	3	2.75
Highway speed limit	4	1	2	4	2.75
Heavy vehicles	3	5	0	1	2.25
Humps	1	4	0	3	2.00
Dips	1	4	0	1	1.50
No train horn allowed	0	1	2	4	1.75
Pavement type	2	2	0	2	1.50
Passenger Trains		4			4.00
Haz-mat route	1	5	3	4	3.25
Approach grade	2	4	0	1	1.75

Each set of survey responses was normalized into consistent weights using the Analytic Hierarchy Process (AHP) after rescaling outliers (tendencies to rate either too high or too low compared to other responses). The final weights are the average of the normalized weights, rescaled to the original 0 to 5 scale.

### **Methodology**

The Analytic Hierarchy Process (AHP) is another Decision Theory tool with procedures to check the consistency of judgments used in determining priorities (ref. 20). The small size of the available survey increases the importance of ensuring the responses' consistency before combining them into one set of weights. The AHP normalization procedure is based on pairwise comparisons on the scale depicted in [Table 6-8](#).



**Table 6-8 AHP Fundamental Scale for Pairwise Comparisons**

<i>Relative</i>	<i>Importance</i>	<i>Explanation</i>
1	Equal importance	Both factors contribute equally
3	Somewhat more important	Experience and judgment slightly favor one over the other
5	Much more important	Experience and judgment strongly favor one over the other
7	Very much more important	Experience and judgment very strongly favor one over the other. Importance demonstrated in practice
9	Absolutely more important	The evident favoring one over the other is of the highest possible validity
2,4,6,8	Intermediate values	When compromise is needed

Source: Ref. 20

The AHP methodology is implemented in three steps. They are illustrated here with one respondent's ratings, but were implemented for all four.

*Step 1: Pairwise Comparison Matrix*

The 13 TPCI variables are organized into a 13 by 13 matrix of the type illustrated in Table 6-9. The principal diagonal elements of the matrix are always 1 because each attribute is as important as itself. The top half of the matrix contains the pairwise comparisons, obtained by rescaling the survey results according to Table 6-8. Each element at the bottom half of the matrix is the inverse of its symmetrical, as depicted in Equation 6-2.

$$a_{ij} = \frac{1}{a_{ji}} \quad [6-2]$$

*Step 2: Consistency Check*

The overall consistency is verified using the consistency ratio (CR) depicted in Equation 6-3. The value of consistency ratio should be less than or equal to 10 percent for acceptable consistency among answers. If the consistency ratio is greater than 10 percent, the judgments are affected by randomness and need to be revised.

$$CR = \frac{CI}{RI} \quad [6-3]$$

**Table 6-9 Pairwise Comparison Matrix**

	# Trains	School buses	Accidents	Heavy vehicles	AADT	Nearby traffic signal	# Tracks	Train speed	Sight distance	Dip Hump	Nearby intersection	Approach angle	Speed limit
# Trains	1	1	1	1	3	3	3	3	3	3	3	5	9
School buses	1.0000	1	1	1	3	3	3	3	3	3	3	5	9
Accidents	1.0000	1.0000	1	1	3	3	3	3	3	3	3	5	9
Heavy vehicles	1.0000	1.0000	1.0000	1	3	3	3	3	3	3	3	5	9
AADT	0.3333	0.3333	0.3333	0.3333	1	1	1	1	1	1	1	3	7
Nearby traffic signal	0.3333	0.3333	0.3333	0.3333	1.0000	1	1	1	1	1	1	3	7
# Tracks	0.3333	0.3333	0.3333	0.3333	1.0000	1.0000	1	1	1	1	1	3	7
Train speed	0.3333	0.3333	0.3333	0.3333	1.0000	1.0000	1.0000	1	1	1	1	3	7
Sight distance	0.3333	0.3333	0.3333	0.3333	1.0000	1.0000	1.0000	1.0000	1	1	1	3	7
Dip Hump	0.3333	0.3333	0.3333	0.3333	1.0000	1.0000	1.0000	1.0000	1.0000	1	1	3	7
Nearby intersection	0.3333	0.3333	0.3333	0.3333	1.0000	1.0000	1.0000	1.0000	1.0000	1.0000	1	3	7
Approach angle	0.2000	0.2000	0.2000	0.2000	0.3333	0.3333	0.3333	0.3333	0.3333	0.3333	0.3333	1	5
Speed limit	0.1111	0.1111	0.1111	0.1111	0.1429	0.1429	0.1429	0.1429	0.1429	0.1429	0.1429	0.2000	1

Where

CR = consistency ratio.

RI = Random index, equal to 1.56 for 13 variables (ref. 20).

CI = Consistency index obtained as depicted in Equation 6-3.

$$CI = \frac{\lambda_{max} - n}{n - 1} \tag{6-3}$$

$\lambda_{max}$  = Principal Eigen value of the comparison matrix.

$n$  = Size of the comparison matrix (13).

The procedure to calculate a matrix’s principal Eigen value can be found in the literature (e.g., Ref. 27). The result for the matrix depicted in Table 6-9 is  $\lambda_{max} = 13.2783$ , resulting in a consistency ratio of 0.0149 for that respondent. The other ratios were 0.0129, 0.0138, and 0.0123, all considerably lower than 0.1, the upper limit of acceptability.

*Step 3: Normalization*

AHP’s iterative procedure to normalize consistent weights consists of squaring the pairwise matrix, obtaining its Eigen vector, and repeating the procedure until the Eigen vector does not change. The final Eigen vector contains the normalized numbers. Table 6-10 shows the final results. Considering that all respondents are equally qualified, the final TPCI weights are the average of the four, rescaled to the original 0 to 5 scale. The sum of the weights is 39.5424.

**Table 6-10 Final Weights**

Attribute	Respondent 1	Respondent 2	Respondent 3	Respondent 4	Average	Final Weights
Five-year crashes	0.0495	0.1464	0.1074	0.2196	0.1307	5
Daily trains	0.1335	0.1464	0.1074	0.0904	0.1195	4.778
Daily school buses	0.1335	0.1464	0.1074	0.0904	0.1195	4.778
Number of tracks	0.1335	0.0543	0.1074	0.0904	0.0964	3.8568
Train speed	0.1335	0.0543	0.1074	0.0904	0.0964	3.8568
AADT	0.1335	0.0543	0.1074	0.034	0.0823	3.2922
Nearby traffic signal	0.0495	0.0543	0.1074	0.0904	0.0754	3.016
Sight distance	0.0495	0.0543	0.1074	0.0904	0.0754	3.016
Trucks per day	0.0223	0.1464	0.0126	0.0116	0.0483	1.93
Nearby intersection	0.0495	0.0543	0.0427	0.034	0.0451	1.8038
Highway speed limit	0.0495	0.0102	0.0213	0.0904	0.0428	1.7132
Approach angle	0.0495	0.0241	0.0427	0.034	0.0375	1.5016
Dip/hump	0.0133	0.0543	0.0213	0.034	0.0307	1
<b>Sum of weights</b>						<b>39.5424</b>

## Results, Conclusions, and Recommendations

Using the weights from [Table 6-10](#) and calculating the variables utilities as explained above, the Texas Passive Crossings Index becomes [Equation 6-6](#).

$$\begin{aligned}
 TPCI = & (5U_{5yr\_cr} + 4.778U_{trains} + 4.778U_{schbus} + 3.8568U_{track} + 3.8568U_{tr\_speed} \\
 & + 3.2922U_{AADT} + 3.016U_{signal} + 3.016U_{SD} + 1.93U_{trucks} + 1.8038U_{nearint} \\
 & + 1.7132U_{hwy\_sp} + 1.5016U_{crossangle} + U_{diphump} + )/39.5424
 \end{aligned}$$

Where:

TPCI = Texas Passive Crossings Index.

U = utilities assigned/calculated as previously explained.

Utility(“U”) subscripts are as follows:

Five-year crashes = *5yr\_cr*

Daily trains = *trains*

Daily school buses = *schbus*

Number of tracks = *track*

Train speed = *tr\_speed*

AADT = *AADT*

Nearby traffic signal = *signal*

Sight distance = *SD*

Trucks per day = *trucks*

Nearby intersection = *nearint*

Highway speed limit = *hwy\_sp*

Approach angle = *crossangle*

Dip/hump = *diphump*

In order to demonstrate consistency between the TPCI and the warrants, as well as its adequacy as a ranking index for the passive crossings, the index was calculated for the 2,663 crossings in the eligible set (obtained by disqualifying passive crossings with the criteria explained in [Chapter 5](#)). The eligible set contains 1,115 warranted crossings and 1,548 non-warranted crossings. Non-warranted crossings will not be selected for inspections, but were included because it was necessary for the discussions below.

In order to be a useful ranking tool that is compatible with the warrants and fulfills this project's objectives, TPCI must be:

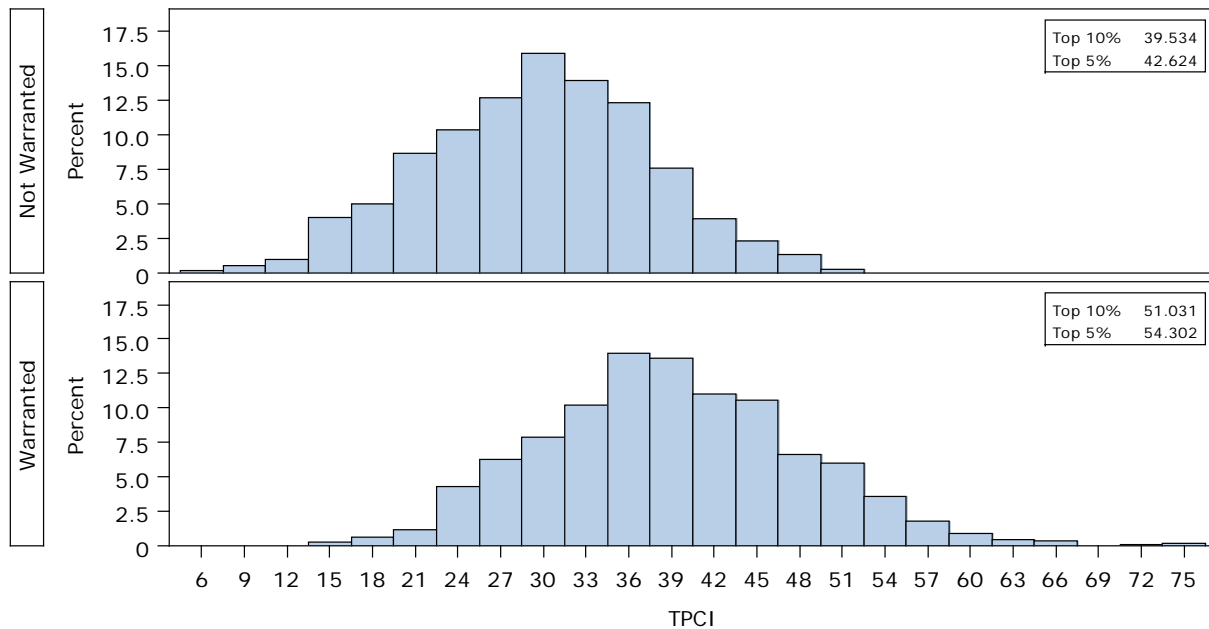
- Higher for warranted than non-warranted crossings.
- Sensitive to differences in the characteristics of passive crossings in the warranted set.
- Better at ranking warranted passive crossings than the original TPI.

[Figure 6-5](#), which compares the TPCI distribution for the warranted and non-warranted crossings, demonstrates the first two TPCI properties. TPCI is clearly higher for the warranted than non-warranted crossings, but it is not concentrated within a small range of TPCI values. The latter would mean insensitivity to variations among warranted crossings and thus inability to properly rank the warranted set.

In order to verify the third property (TPCI is ranks passive crossings better than the original TPI), two passive-only priority lists were compared. They were both prepared from the eligible set of 2,663 passive crossings (i.e., excluding all non-qualifying passives and all actives). The first list was prioritized by number of warrants met, then TPCI. The second ranked these 2,663 crossings by the original TPI. The priorities obtained when sorting these 2,663 crossings by the original TPI were compared to the top 100 of the proposed priority list, considering that TxDOT usually inspects at most approximately 100 passive crossings each year.

The original TPI assigned priorities ranging from 102 to 2,582 to 58 crossings in the top 100 of the proposed priority list. [Table 6-11](#) illustrates some of the crossings the original TPI ranked at the bottom of the prioritized eligible set and lists the reasons why the proposed methodology gave them a considerably higher priority for inspection.

After implementation, the proposed method (described in [Chapters 5 and 6](#)) generates a prioritized list of warranted passive crossings, which needs to be combined with the active crossings to generate the overall priority list. The next chapter discusses the alternatives for the integrated prioritization methodology.



**Figure 6-5 TPCI Distributions for Warranted and Non-Warranted Crossings**

**Table 6-11  
Examples of Crossings with Risk Factors and Low Priorities with the Original TPI**

<i>Crossing Number</i>	<i>Priority with Proposed Method</i>	<i>Original TPI Priority within the Eligible Passives</i>	<i>Reasons for proposed high priority</i>
020532H	2 <sup>nd</sup>	748 <sup>th</sup>	2 crashes, nearby traffic signal present, 98 percentile trucks, 97 percentile AADT, and 96 percentile train speed
790236V	6 <sup>th</sup>	723 <sup>rd</sup>	1 crash, dip/hump, 26 school buses/day, 98 percentile trucks, and 93 percentile AADT
448851M	14 <sup>th</sup>	2,582 <sup>nd</sup>	1 crash, nearby intersection, 40 school buses/day, 99 percentile trucks, 99 percentile AADT
794578J	86 <sup>th</sup>	243 <sup>rd</sup>	2 tracks, nearby intersection, highway speed=55mph, 100 percentile trains per day, and 94 percentile train speed
288325G	97 <sup>th</sup>	1424 <sup>th</sup>	1 crash, 2 tracks, dip/hump, 95 percentile trucks and 92 percentile AADT

## **CHAPTER 7**

### **INTEGRATED PRIORITIZATION METHODOLOGY**

#### **Introduction and Objective**

The main goal of this project is to develop a rail crossing prioritization methodology capable of identifying passive (low-volume) crossings with risk factors and prioritizing them over active crossings with less potential risk but higher volumes. In order to ensure that this objective would be attained, the project has two deliverables: warrants for passive crossings (discussed in [Chapter 5](#)) and the revised Texas Priority Index (TPI<sub>rev</sub>, [Chapter 4](#)). In addition, the researchers developed the Texas Passive Crossings Index (TPCI, [Chapter 6](#)), to ensure that the warranted crossings would be properly prioritized.

TPI<sub>rev</sub> is based on a newly calibrated statistical model of crash predictions. As discussed below, while it is considerably superior to the original TPI to prioritize active crossings, it continues to place most passive crossings at the bottom of the priority list. TPCI is based on Utility Theory, a Decision Theory framework to compare and prioritize alternatives based on the potential impact of each alternative's characterizing variables on the potential for outcome underlying the prioritization procedure. As demonstrated in [Chapter 6](#), TPCI is a very good index to prioritize the warranted set.

These two methods generate two priority lists, one with active crossings and the other with warranted passives. This chapter discusses alternative methodologies to integrate both lists in a single priority list. In order to attain the project's main goal, this methodology must identify passive, low-volume crossings with most risk factors from the top of the passive list, and correctly place them at the top of the overall list that should also contain the active crossings with potential risk.

#### **Acceptability Criteria for Integrated Prioritization Methods**

The basic approach consisted of analyzing the priority lists generated by tentative prioritization methods, starting from the simplest to code, until an adequate method was found. The priority list generated by each tentative method was analyzed based on the following criteria:

- The method should automatically place active and passive crossings with risk factors at the top of the list.
- The top of this automated priority list should contain at least  $\frac{2}{3}$  actives and  $\frac{1}{3}$  passives, since the current passive to active proportion is close to these ratios (62 percent to 38 percent).
- The priority list should contain only warranted passives. If considered by prioritization procedure, non-warranted passives should all appear at the bottom of the list.

- The top of the automated list should include all passives meeting the largest number of warrants and a significant number of passives meeting multiple warrants.
- Passives and actives should be evenly distributed around the top priorities, without predominance of either type of crossing.
- The ideal method should include all active crossings with multiple crashes at the top of the automated priorities. At a minimum, the top should include at least the same active crossings with multiple crashes placed at the top when sorting the overall list by  $TPI_{rev}$ .

The data set used in this analysis contains 9,896 crossings (62 percent actives and 38 percent passives). The data were extracted from TxRAIL 2011 GxFORM and tblCONTROLS tables, and the most recent accident history (2007–2011) was used all calculations. For average daily traffic data (AADT), the analysis uses the maximum of AADT and PAADT to ensure conservative results in terms of exposure.

$TPI_{rev}$  was calculated for all crossings that had data for its variables. The warranting procedure discussed in [Chapter 5](#) was applied to the passive crossings, and they were classified as listed below. TPCI was calculated for the 2,663 passive crossings that met the initial eligibility criteria, resulting in the following breakdown:

Actives .....	6,140
Passives .....	3,756
<i>Eligible warranted*</i> .....	1,115
<i>Eligible not warranted*</i> .....	1,548
<i>Not eligible*</i> .....	1,093

The researchers recommend excluding non-warranted passive crossings from the prioritization procedure. For this analysis, however, it was necessary to include in this analysis at least some non-warranted passives in order to assess the methods’ sensitivity to warranted crossings. Therefore, the analysis considers the 6,410 actives, 1,115 warranted passives and 1,548 non-warranted but eligible passives. Eligibility criteria are discussed in [Chapter 5](#). Non-eligible passive crossings are removed from the warranting procedure when they serve less than two daily trains, have no accidents in the past 5 years, and meet a list of additional non-qualification criteria developed in this project.

## **Alternatives Based on Overall $TPI_{rev}$ Priorities**

### **Description**

Two alternatives were proposed that sort the entire list of 9,896 crossings by  $TPI_{rev}$  and use the warrants only if it is necessary to select additional passive crossings. These alternatives are the simplest to code, requiring only the two formulas for the  $TPI_{rev}$  calculation, and coding of the warranting procedure.

Alternative 1 was proposed by the PMC in an email sent on 8/3/12, replicated below.

“The revised priority index would be run against all eligible crossings in TRIMS and then the warrants calculation check run against the remaining passive crossings that do not otherwise qualify using the revised priority index calculation. Any of the subset of passive crossings meeting warrants would then be added to the list of crossings meeting an established priority index threshold.”

Alternative 2 was proposed during a meeting between the TTI team and the PMC on July 10, 2012. Below is the TTI email describing the proposed methodology to the UTSA team.

“Run the Priority index on all open, public, active and passive crossings in order to come up with a top 200 (or so) for further investigation. This list could include some passive crossings.

Then the warrants would be run on all the remaining passive crossings to determine a set of passive crossings to be added to the 200 (or so) for further investigation... The 200 (or so) is a sliding number of crossings for further investigation based on the types of potential projects and funding levels for that given year.”

The difference between these alternatives is that the first defines the top of the priority list using a  $TPI_{rev}$  threshold and the second defines it based on managerial factors. In order to assess these alternatives, it is first necessary to assess  $TPI_{rev}$  ability to compare warranted passive crossings to actives and correctly select and reasonable number of them at the top of the list. It is also necessary to define the  $TPI_{rev}$  threshold required by alternative 1.

### **$TPI_{rev}$ Sensitivity Analysis**

As discussed in [Chapter 4](#),  $TPI_{rev}$  is the value of the predicted crashes ( $\hat{\mu}$ ) corrected for the observed number of crashes in the past five years (plus 0.1 to consider zeroes) and rescaled by a factor of 1000.  $TPI_{rev}$  is shown in [equation 7-1](#).

$$TPI_{rev} = 1000 * \hat{\mu} * (A_5 + 0.1) \quad [7-1]$$

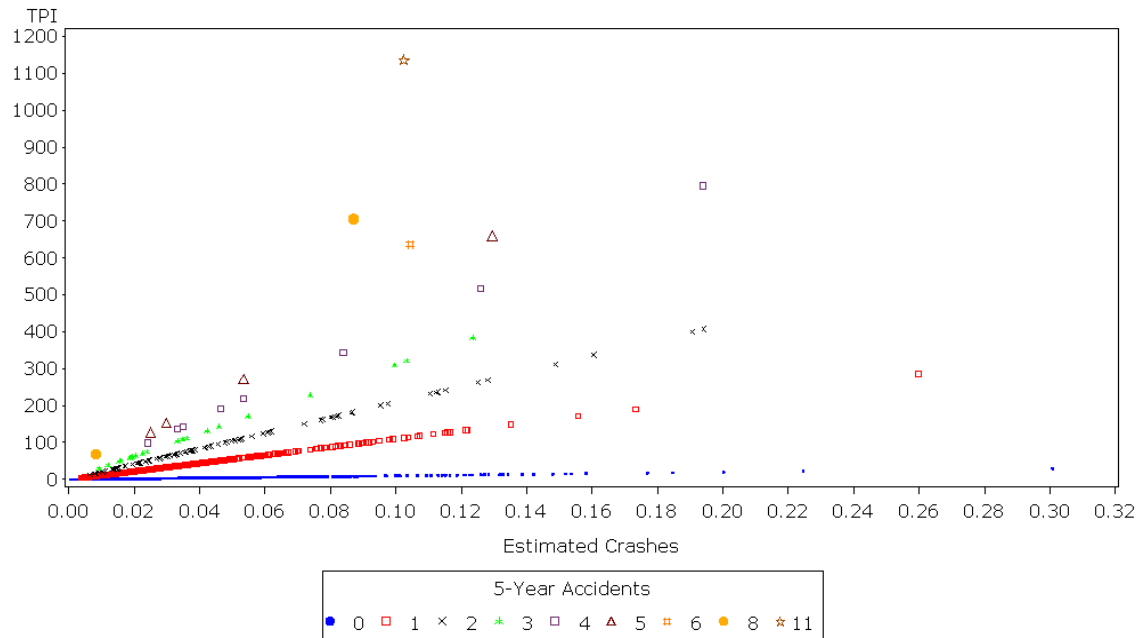
Where:

$\hat{\mu}$  = estimated number of crashes per year for each crossing. This formula is documented in [Chapter 4](#).

$A_5$  = number of crashes in last five years.

Since the crash prediction equation considers the logarithm of the AADT (see [Chapter 4](#)),  $TPI_{rev}$  emphasizes AADT less than the original TPI. On the other hand, the correction factor depicted in [equation 7-1](#) emphasizes crossings with multiple crashes, a desirable index property. However, this favors active crossings in an overall prioritization, since multiple crashes occur about 3 times more often in active than in passive crossings. [Figure 7-1](#) helps visualize the influence of the observed number of five-year crashes on  $TPI_{rev}$  values.





**Figure 7-1 Revised TPI and Number of 5-Year Crashes**

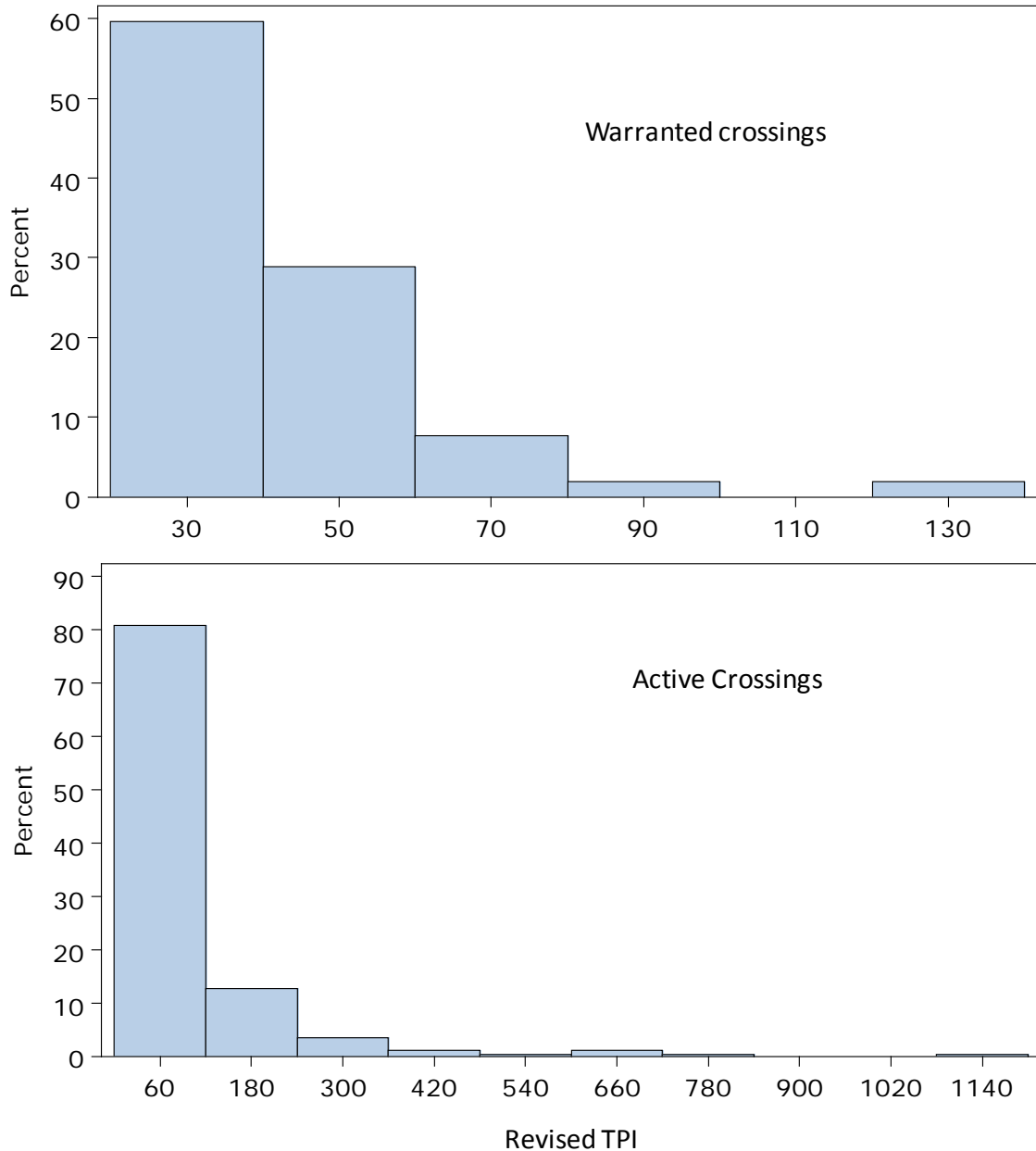
Table 7-1 shows  $TPI_{rev}$  statistics by crossing type and eligibility for the warranting procedure.  $TPI_{rev}$  is considerably higher for active than passive crossings. This is not surprising. As previously discussed, it is extremely challenging if not altogether impossible to derive a prioritization index capable of properly considering AADT and crash history in the crash prediction, and of at the same time capable of identifying passive crossings with significantly lower AADTs, less multiple crashes but other risk factors.

**Table 7-1 Basic Statistics of the Revised TPI**

	<b>Number of Crossings</b>	<b>Min.</b>	<b>Mean</b>	<b>95%</b>	<b>99%</b>	<b>Max.</b>	<b>Std. Deviation</b>
<b>Actives</b>	6,140	0.103	8.28	33.86	117.30	1,138.01	33.96
<b>Passives</b>							
<i>Not Eligible</i>	1,093	0.077	0.45	0.87	1.46	2.75	0.27
<i>Not Warranted</i>	1,548	0.209	1.30	2.78	4.02	8.31	0.78
<i>Warranted</i>	1,115	0.322	5.12	23.83	51.75	136.31	10.42
<b>Total</b>	9,896	0.077	6.13	23.84	91.25	1,138.01	27.59

Table 7-1 shows that  $TPI_{rev}$  is consistent with the warranting procedure documented in Chapter 5. The warranted crossings have the greatest values of  $TPI_{rev}$ , the crossings that did not meet the eligibility criteria have the smallest, and those meeting the eligibility criteria but not the warrants are in between. Analogous results were observed for other percentiles not shown in Table 7-1.

Considering that only the top of the priority list will be inspected, it is more important to analyze the high values. Figure 7-2 compares the distribution of the highest 5 percent  $TPI_{rev}$  values for warranted passive and active crossings. The top  $TPI_{rev}$  is considerably higher for the active crossings, suggesting that a prioritization method that uses  $TPI_{rev}$  to rank all crossings is likely to place few warranted passive crossings at the top of the list.



**Figure 7-2 Histograms of the 5% Highest  $TPI_{rev}$  Values**

The  $TPI_{rev}$  threshold to define the top of the list (required by alternative 1) was defined based on the fact that TxDOT usually selects for inspection at most 2 percent to 3 percent of the crossings each year. Therefore, the “top of the list” threshold must correspond to a

value between the 97% and 98% percentiles of the  $TPI_{rev}$ . These percentiles are, respectively, 40.1 and 57.2 for the data used in this analysis. A conservative threshold to test this alternative would be 45.

## Results and Conclusions

Alternative 1 priority list was obtained by sorting the 9,896 crossings by  $TPI_{rev}$ . The top of the list was obtained by applying the threshold defined above. It comprises 268 crossings, with the following breakdown: 19 warranted passives, 1 non-warranted passive and 248 actives. A total of 113 actives had multiple crashes; the top of the list has 90 actives with multiple crashes. In alternative 2, the top 200 crossings ranked by  $TPI_{rev}$  included 189 actives 11 passives. Out of the passives, 3 met 1 warrant, 2 met 4, 3 met 3, and 1 met 4 warrants. Out of the actives, 90 had multiple crashes.

**Table 7-2 Top of the Priority Lists Generated with  $TPI_{rev}$  and Original TPI**

<i>Crossing Characteristics</i>	<i>Alternative 1</i>	<i>Original TPI</i>	<i>Alternative 2</i>	<i>Original TPI</i>
<i>Passive Warranted</i>	19	10	11	8
<i>Passive Non-warranted</i>	1	4	0	2
<i>Passive Total</i>	20	14	11	10
<i>Active Multiple crashes</i>	90	45	90	40
<i>Active No multiple crashes</i>	158	209	99	150
<i>Active Total</i>	248	254	189	190
<i>Total</i>	268	268	200	200

$TPI_{rev}$  is considerably more sensitive to multiple crashes in active crossings than the original TPI, but it is almost as insensitive to warranted passive crossings as the original. With these alternatives, the passive crossings would continue to be manually selected for inspection.

The main findings from this analysis are:

- An efficient prioritization methodology must start with the warranting procedure described in [Chapter 5](#), to eliminate non-warranted crossings from the prioritization process and consider the number of warrants each crossing met as a prioritization variable.
- Since  $TPI_{rev}$  is better adjusted to current data, considers more variables and is compatible with the warranting procedure (see [Table 7-1](#)), it is worthwhile investigating if there is a  $TPI_{rev}$  correction factor able to compensate its tendency to prioritize active over passive crossings.

## Alternatives Based on Adjusted $TPI_{rev}$ Formulas

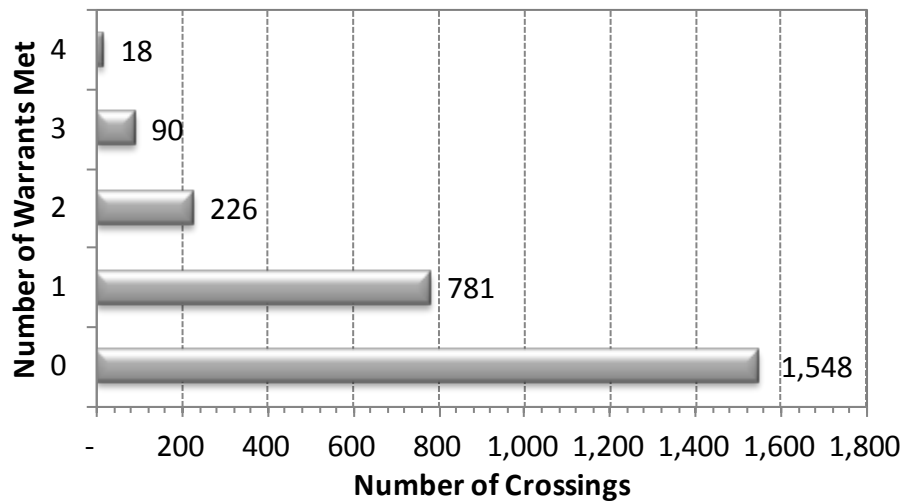
The researchers discussed several possibilities for an overall index that would give fair consideration to active and passive crossings, and analyzed them based on the same acceptability criteria previously discussed under “Acceptability Criteria for Prioritization Methods.” The analysis considers as “top of the list” approximately 300 crossings. The index adjustment is considered appropriate if:

- The adjusted index places approximately 200 actives and 100 passives at the top 300 of the priority list.
- Passives and actives are evenly distributed around the top 300 list.
- The top 300 include the 18 passives meeting the maximum (4) warrants and a significant number of passives meeting 2 or 3 warrants.
- The top 300 include the 21 passives with multiple crashes, especially the 3 passive crossings with 3 crashes and the single passive crossing with 4 crashes.
- The top 300 includes at least the same 90 active crossings with multiple crashes obtained in the overall ranking described in the previous alternatives. The ideal method should include all 113 active crossings with multiple crashes in the top 300.

For the readers’ convenience, data presented in previous chapters is repeated below. [Table 7-3](#) depicts the number of crashes observed in active and warranted passive crossings, and [Figure 7-3](#) depicts the number warranted passives meeting 1, 2, 3, and 4 warrants (4 is the maximum for the data analyzed).

**Table 7-3 Crashes in the 2007–2011 Period**

Crashes in 2007-2011	Active Crossings	Warranted Passive Crossings
0	5,599	938
1	428	156
2	78	17
3	20	3
4	7	1
5	4	
6	1	
8	2	
11	1	
Total	6,140	1,115
<i>Multiple crashes</i>	<i>113</i>	<i>21</i>



**Figure 7-3 Warranted Crossings by Number of Warrants Met**

All results presented in this section were obtained with a data set comprising 7,225 crossings: 6,140 actives and 1,115 warranted passives. The previous analyses demonstrate that an efficient prioritization methodology starts with the warranting procedure, eliminating non-warranted crossings from consideration and using the number of warrants met as a prioritization variable.

**Adjusted  $TPI_{rev}$**

Table 7-4 illustrates the top 300 crossings obtained when sorting the 7,255 crossings with the tentative formulations in the first column. When the number of passives in the top 300 was close to 100, the adjustment factor adequacy was further verified as indicated. Variables in the first column of Table 7-4 are as follows:

- nw = number of warrants met.
- c = number of crashes in the most recent five-year period (2007–2011).
- mc = binary variable that takes the value of 1 for multiple crashes and 0 when  $c \leq 1$ .

The best results in terms of top 300 priorities were obtained when multiplying the warranted crossings'  $TPI_{rev}$  by  $[1.5*(nw+c)]$ . The active/passive splits were 56 percent-44 percent for the top 100, 69 percent-31 percent for the mid-200 and 68 percent-32 percent for the last 200. The bottom 3<sup>rd</sup> of the 7,255 crossings list contained 86 percent actives and 13 percent warranted passives. Among these, there were 28 crossings with crashes (13 actives and 15 passives). Among the crossings with crashes at the bottom of the list, 5 actives and 4 passives had multiple crashes. It was not possible to develop an

adjustment factor that makes  $TPI_{rev}$  equally sensitive to passives meeting multiple warrants and to actives with multiple crashes. Decreasing the adjustment factor makes it insensitive to passives, and increasing it makes it insensitive to actives with multiple crashes.

**Table 7-4 Top 300 Crossings with Tentative  $TPI_{rev}$  Adjustments**

Multiply $TPI_{rev}$ of Warranted Passives by	Passives				Total	Actives Multiple Crashes (113)	Comments
	Total	NW=3 (90)	NW=4 (18)	Multiple Crashes (21)			
A constant. Best results: 4	113	16	5	16	187	90	Insensitive to multiple warrants
(nw+mc)	43						Adjustment insensitive to passives
2*(nw+mc)	60						
3*(nw+mc)	69						
4*(nw+mc)	74						
1.5*(nw+c)	107	18	8	17	213	90	Best results

### Intermediate Variable $\hat{\mu}$

The first step in the  $TPI_{rev}$  calculation is to obtain  $\hat{\mu}$ , which estimates one-year crashes (see equation 7-1). Table 7-5 compares the observed crash frequencies to median and mean  $\hat{\mu}$ . Table 7-5 shows that  $\hat{\mu}$  reflects the crash frequencies observed in 2011 for active crossings, but somewhat overestimates the crashes for passive crossings. Nevertheless,  $\hat{\mu}$  is consistent: the active estimates are approximately twice that of passives in all percentiles, as depicted in Table 7-6.

**Table 7-5 Predicted Yearly Crash Probabilities and Observed 2011 Frequencies**

Crossing Type	Crashes/crossing Observed in 2011	$\hat{\mu}$ median	$\hat{\mu}$ mean
Active	0.020	0.022	0.025
Passive	0.008	0.012	0.015

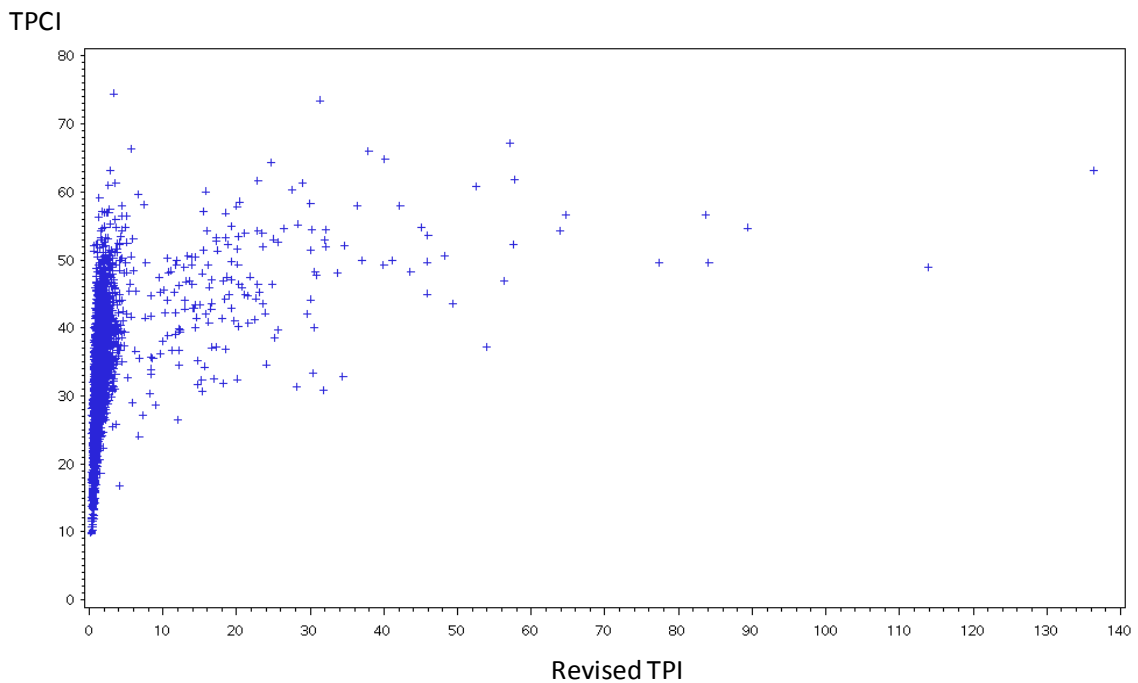
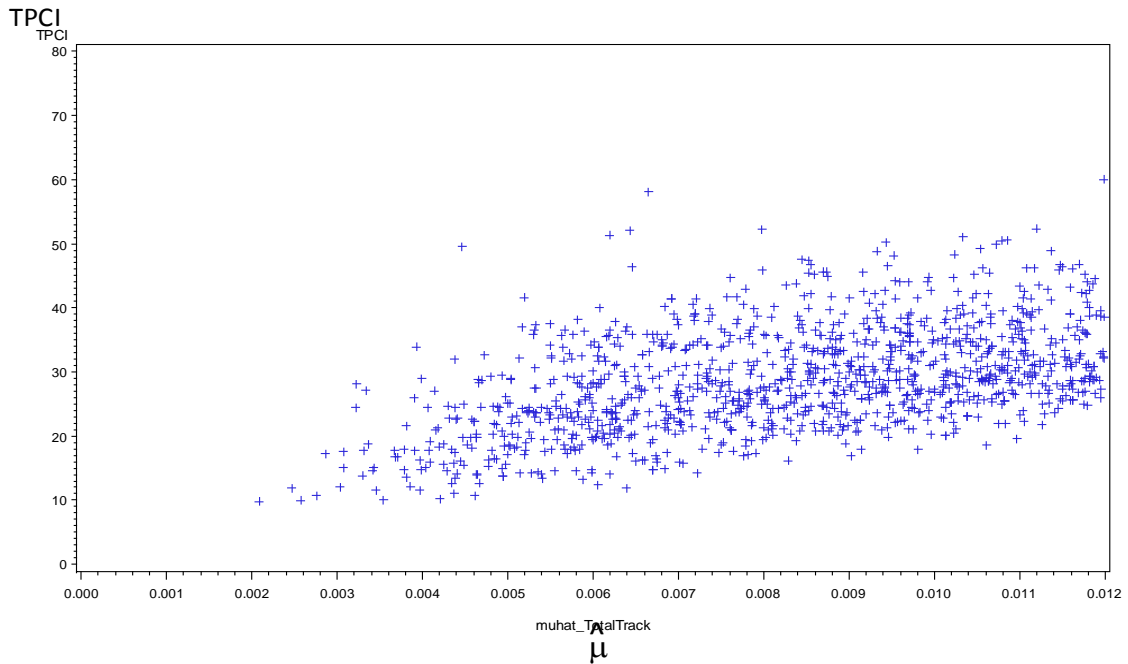
**Table 7-6 Quantiles of Predicted Crash Probabilities for Active and Passive Crossings**

<i>Actives</i>		<i>Passives</i>	
<b>Quantile</b>	<b>Estimate</b>	<b>Quantile</b>	<b>Estimate</b>
100% Max	0.44016778	100% Max	0.22460143
99%	0.10663999	99%	0.04821874
95%	0.06183245	95%	0.03252666
90%	0.04916485	90%	0.02582486
75% Q3	0.03353038	75% Q3	0.01791731
50% Median	0.02227080	50% Median	0.01232754
25% Q1	0.01486941	25% Q1	0.00857885
10%	0.00995652	10%	0.00610785
5%	0.00768683	5%	0.00519140
1%	0.00423566	1%	0.00380947
0% Min	0.00107065	0% Min	0.00208621

The Pearson correlation coefficient between TPCI (see [Chapter 6](#)) and  $\hat{\mu}$  is 0.51, while it is 0.39 for the correlation between TPCI and TPI. [Figure 7-4](#) helps visualize this difference in correlations.

TPCI was designed to capture variations found among passive crossings (see [Chapter 6](#)), a necessary property for a ranking index. Variable  $\hat{\mu}$  is more sensitive to variations found among the warranted passive crossings than  $TPI_{rev}$ . [Figure 7-4](#) also helps visualize this property. In the top graph,  $\hat{\mu}$  increases as TPCI increases, and the graph has a uniform spread, while the bottom graph shows significant concentration of data points at low  $TPI_{rev}$  values, indicating less sensitivity to TPCI—and therefore to passive crossings’ characteristics.

When used in conjunction with the number of warrants met and a binary variable to indicate whether or not the crossing had multiple crashes,  $\hat{\mu}$  generated a rather reasonable prioritized list of warranted passive crossings. The intermediate variable  $\hat{\mu}$  is not recommended in lieu of  $TPI_{rev}$  to rank the active crossings;  $\hat{\mu}$  fails to place active crossings with multiple crashes at the top of the list, while  $TPI_{rev}$  does not.



**Figure 7-4 Correlation between TPCI-Revised TPI and TPCI- $\hat{\mu}$**

### Summary of Findings

- Prioritization methods that sort the entire list of crossings by  $TPI_{rev}$  are almost as insensitive to passive crossings as the original TPI. Favoring high-volume crossings is an intrinsic property of any priority index based on statistical models that consider AADT, due to the considerable difference in order of AADT magnitude between active and passive crossings.



- Historically, the five-year crashes/crossing rate is around 3.5 times higher for active crossings than for passives. For yearly accidents, this difference is between 2 and 3. In terms of the integrated prioritization methodology, this fact further lowers the passive crossings' priorities in an overall ranking procedure based on  $TPI_{rev}$  and further decreases its sensitivity to passive crossings (see [Figure 7-1](#)).
- An efficient prioritization methodology must start with the warranting procedure described in [Chapter 5](#) in order to: (1) eliminate non-warranted crossings from the prioritization process and (2) consider the number of warrants met as a prioritization variable.
- Multiplying the warranted crossings'  $TPI_{rev}$  values by the best adjustment factor found [ $1.5*(nw+c)$ ] resulted in balanced top 300 priorities in terms of number of active and passive crossings. However, these top 300 included less than half the passives meeting 4 (maximum) warrants, and failed to include 23 active crossings multiple crashes. The researchers could not find a  $TPI_{rev}$  adjustment factor equally sensitive to multiple warrants and multiple crashes in actives.
- Variable  $\hat{\mu}$  (necessary for  $TPI_{rev}$  calculation) prioritizes warranted crossings reasonably well when used in conjunction with the warrants and a multiple crash indicator. However, it does not prioritize the active crossings well.
- The integrated prioritization methodology must not overlook crossings with risk factors due to lack of a  $TPI_{rev}$  variable (which means lack of a calculated index). In this analysis, there were 582 active crossings and 83 passive crossings without  $TPI_{rev}$  values. Actives: 9 had 1 crash and 5 had multiple crashes. Passives: 79 warranted, 33 met multiple warrants and 4 had multiple crashes.
- The only way to ensure that the top of the priority list balances active and warranted passive crossings and contains the crossings with most risk factors from each category is to prioritize actives and warranted passives separately, include crossings with missing index values and risk factors in the top of their respective priority lists, append the tops of the two lists, and sort based on the rescaled ranks. This sorting procedure reflects the assumption that actives and warranted passives are equally important in the integrated top priorities.

## **Recommended Prioritization Methodology**

The recommended prioritization methodology addresses the findings summarized above and generates top priorities that contain a balanced number of passives and actives with greatest potential risk factors, including those with missing  $TPI_{rev}$ .

### **Overview**

The proposed approach starts by prioritizing separately the warranted passives and the actives, ensuring that crossings with important risk factors and missing  $TPI_{rev}$  values

appear at the top of each list. The top of the overall priority list is obtained by appending the top of the active and passive lists prepared separately, then sorting by an adjusted index. The remaining actives and warranted passives are appended and sorted, but their priorities (ranks) start from the last priority of the top list plus one. If non-warranted passive crossings must also appear in the priority list, they can be appended to the bottom of the overall list and assigned the bottom priority, since the warranting procedure already eliminated them from consideration.

## **Development and Implementation**

### *Step 1—Estimate the size and composition of the top priorities.*

The total number of crossings at the top of the priority list should be a TRIMS input corresponding to the inspection capabilities in that year, plus an extra number to be conservative. This analysis will consider 300 crossings: the average 200 inspected each year plus another 100 to be very conservative.

TRIMS should provide a default proportion of active and warranted passive crossings making up the top priorities based on the latest proportion of open, public active and passive crossings (62 percent to 38 percent in 2011). TRIMS should allow the manager to examine and, if necessary, override the calculated default proportion when policies or funding issues indicate that a different active-to-passive split is more suitable for that round of inspections. Alternatively, the number of actives and number of passives can be direct inputs. The analysis below uses 1/3 passives and 2/3 actives, i.e., a top priority list containing approximately 100 passives and 200 actives as starting values.

### *Step 2—Prioritize active crossings*

Create and rank the active set. Create a file with all open, public, active crossings. Calculate  $TPI_{rev}$  and sort the active list by descending  $TPI_{rev}$ . Create variable RA (“Rank-Active”) starting from 1 for the top priority and ensuring that repeated values of  $TPI_{rev}$  have the same value of RA. Put all crossings with  $RA \leq 200$  (or another number selected in step 1) into file A\_TOP. Put the remaining actives into A\_BOTTOM. In this analysis, there were no repeated values of  $TPI_{rev}$  in A\_TOP, so it has exactly 200 active crossings.

Address missing variables and update ranks. Remove all active crossings with multiple crashes in the past five years and missing  $TPI_{rev}$  values from A\_BOTTOM (creating file A\_BOTTOM<sub>2</sub>) and append to A\_TOP (creating file A\_TOP<sub>2</sub>). In this analysis, A\_TOP<sub>2</sub> had 214 active crossings and A\_BOTTOM<sub>2</sub> the remaining 5,926. Since the extra 14 crossings have no  $TPI_{rev}$  values and cannot be prioritized, assign them  $RA=201$  (number of active crossings determined in step 1 plus one). Recalculate RA in A\_BOTTOM<sub>2</sub> starting from 202 (last A\_TOP<sub>2</sub> rank plus 1).

### Step 2 outcomes:

- File A\_TOP<sub>2</sub> with 214 active crossings ranked from  $RA=1$  to  $RA=201$  (the latter is repeated 14 times).

- File A\_BOTTOM<sub>2</sub> with 5,926 active crossings, ranked from RA= 202 to RA=5694.

*Step 3—Prioritize warranted passive crossings*

Create and rank the warranted set. Apply the warranting procedure described in [Chapter 5](#) to all open, public, passive crossings that serve at least 2 trains per day (plus those with less trains but one or more crashes) and create a file with the warranted passive crossings (1,115 in this analysis).

The best methodology to rank the warranted passives was discussed in [Chapter 6](#) and uses the number of warrants met (nw) and the Texas Passive Crossings Index (TPCI). Responding to the PMC preference of coding only one index in TRIMS, the researchers developed an alternative ranking method for the warranted set. Since [Chapter 6](#) already explained the TPCI in detail, this section will discuss the alternative method.

Create a binary variable termed “mc” (multiple crashes) that takes the value of 1 for crossings with multiple crashes and zero otherwise, and sort the warranted passives by mc, nw (number of warrants met), and  $\hat{\mu}$ . Variable mc is important because, as discussed in [Chapter 4](#), the prioritization must take into account the crash history at each crossing to account for factors that, while impacting each individual crossing, are not included in the prediction equation.

Once the warranted set is sorted, create the ranking variable RW (analogous to RA for active crossings). The last rank was 1018 when sorting by mc, nw and  $\hat{\mu}$ . Split the 1,115 warranted crossings into two files: WP\_TOP with ~~100~~ (or another number of passive crossings established in step 1), and WP\_BOTTOM with the remaining warranted passives. In this case, there was one repeated rank, so WP\_TOP had 101 crossings.

Discussion. Sorting the warranted crossings by mc, nw and  $\hat{\mu}$  placed all 21 warranted crossings with multiple crashes and all 18 crossings meeting 4 warrants (maximum) in top 100 of the warranted list. The alternative method also captured 68 out of the 90 crossings meeting 3 warrants, 4 crossings meeting 2 warrants and 11 crossings meeting 1 warrant. If practical reasons preclude implementing the passive methodology discussed in [Chapter 6](#), the drawback of this alternative method is less sensitivity to: (a) the difference between meeting 1 and 2 warrants, and (b) crossings with 1 crash. The alternative method still ensures that crashes with multiple crashes and/or meeting a large number of warrants are included in the top of the passive priorities.

Address missing variables. If the passive prioritization procedure described in [Chapter 6](#) is implemented, there will be no need to check WP\_BOTTOM. TPCI has valid values when one or more of its component variables are missing and is capable of identifying crossings with potential risk factors when used in conjunction with the warrants.

On the other hand,  $\hat{\mu}$  can have missing values, so it is necessary to check WP\_BOTTOM and create WP\_TOP<sub>2</sub> and WP\_BOTTOM<sub>2</sub> (analogous to A\_TOP<sub>2</sub> and A\_BOTTOM<sub>2</sub> in Step 2). For warranted passives, it is necessary to examine the number of warrants met

and the crash history. The recommended condition to remove crossings from WP\_BOTTOM and append to WP\_TOP is:

$$(nw>2) \text{ or } (nw>1 \text{ and } \text{crashes}>0) \quad [7-2]$$

In this analysis, there were 79 warranted crossings with missing  $\hat{\mu}$  values in WP\_BOTTOM. They are depicted in Table 7-7. None had multiple crashes or met the maximum number of warrants (4). This was expected. The only way WP\_BOTTOM might have crossings with either multiple crashes or maximum number of warrants met is if more than 100 warranted crossings meet the maximum number of warrants and/or have multiple crashes. The 12 crossings highlighted in Table 7-7 met the condition depicted in equation 7-2. They were moved out of WP\_BOTTOM (creating WP\_BOTTOM2) and appended to WP\_TOP (creating WP\_TOP2). In a manner analogous to that discussed for active crossings, recalculate RW in both WP\_BOTTOM2 and WP\_TOP2.

**Table 7-7 Warranted Crossings with Missing Index Data in File WP\_BOTTOM**

<b>Warrants Met</b>	<b>Crashes in 07-11</b>		<b>Total Crossings</b>
	<b>0</b>	<b>1</b>	
1	41	8	49
2	18	2	20
3	9	1	10
<b>Total</b>	<b>68</b>	<b>11</b>	<b>79</b>

Step 3 outcomes:

- File WP\_TOP2 with 113 warranted passive crossings ranked from RW=1 to RW=101.
- File WP\_BOTTOM2 with 1002 warranted passive crossings ranked from RW=102 to RW=1010.

*Step 4—Build the top of the Integrated Prioritization List*

Append A\_TOP2 to WP\_TOP2 (or to WP\_TOP if the passive ranking method described in Chapter 6 is implemented), creating file TOP\_Priorities. If the warranted crossings are sorted by Chapter 6 method, the TOP list has only 314 crossings due to the need to add 14 active crossings with crashes and missing index. In this analysis, it has 327 crossings.

Create the variable “R” by rescaling the passive ranks RW into the same scale as and making R=RA for actives. The simplest way to do this is to multiply RW by the ratio between the number of active and passive crossings selected in Step 1. Equation 7-3 shows how to rescale the ranks and create variable “R.” It is recommended to add a number less than 1 (we used 0.5) to the rescaled rank in order to avoid sequential series of (n<sub>a</sub>/n<sub>p</sub>) repeated final priorities.

$$R = [(n_a/n_p) * RW] + 0.5 \quad \text{for passives} \quad [7-3]$$

$$R = RA \quad \text{for actives}$$

Where:

- $n_a$  = number of active crossings selected in step 1 (200).
- $n_p$  = number of active crossings selected in step 1 (100).
- RW = ranks obtained in step 3 for the top of the warranted list (file WP\_TOP<sub>2</sub>).
- RA = ranks obtained in step 2 for the top of the active list (file A\_TOP<sub>2</sub>).

Sort file TOP by the re-scaled rank R. Create variable “Priority” starting from 1, incrementing by 1, and ensuring that any repeated ranks receive the same “Priority.”

#### Step 4 outcome.

File TOP\_PRIORITIES, with 214 active crossings and 113 warranted passive crossings, ranked based on the rescaled rank R, and assigned integer variable Priority, ranging from 1 to 301.

#### *Step 5—Prioritize the remaining crossings*

If it is necessary or desired to prioritize the remaining crossings, append A\_BOTTOM<sub>2</sub> to P\_BOTTOM<sub>2</sub>. Apply the sorting procedure described in step 4, but start variable “PRIORITY” with the value of the last top “PRIORITY” plus one.

#### *Implementation Recommendations*

Avoiding bugs in the sorting logic. If the sorting logic used in TRIMS does not automatically put missing variables at the bottom of the list, include code to set all missing TPI<sub>rev</sub> and  $\hat{\mu}$  values to -1 during these calculations. A negative value is an easy way to identify missing data when visually inspecting an output and does not affect the prioritization results.

Variable identifying active crossings. When separating the active crossings (step 2), check the actual devices listed in different TxRAIL variables. Variable P\_F takes the values of G for gates, F for flashers and X for all others; therefore, value “X” may include active crossings. For example, there are 45 crossings with bells and P\_F=X in the 2011 data.

## **Results, Conclusions and Recommendations**

### **Results**

The proposed prioritization methodology gives equal importance to active and passive crossings, as summarized in Table 7-8. It shows the summary statistics of variable Priority by crossing type. The mean Priority is only slightly greater for active crossings, and both minima are at the very top of the list. These statistics include the crossings with no index values.

**Table 7-8 Summary of the Integrated Top Priorities by Crossing Type**

<i>Crossing Type</i>	<b>Priority (1<sup>st</sup> to 302<sup>nd</sup>)</b>			
	<i>Mean</i>	<i>Std Dev</i>	<i>Minimum</i>	<i>Maximum</i>
Active (214)	159.9	91.9	1	301
Warranted (113)	166.7	94.7	3	302

Table 7-9 shows the mean priorities by number of crashes. The maximum number of crashes observed at a passive crossing was 4. Crossings with 5, 6, 8, and 11 crashes are all active (see Table 7-3 for a summary of observed crashes in the analysis period). The upper part of Table 7-9 includes all crossings and shows the final priorities the system will output.

**Table 7-9 Summary of the Integrated Top Priorities by Number of Crashes**

<b>Including Missing Index Values (1<sup>st</sup> to 302<sup>nd</sup> Priorities)</b>					
<i>Crashes</i>	<i>Crossings</i>	<i>Mean</i>	<i>Std Dev</i>	<i>Minimum</i>	<i>Maximum</i>
0	71	201.8	77.2	63	302
1	139	195.0	75.4	22	302
2	81	105.9	84.5	6	301
3	20	118.9	102.3	13	301
4	8	35.8	40.4	2	121
5	4	40.0	31.6	5	74
6	1	7.0		7	7
8	2	102.0	138.6	4	200
11	1	1.0		1	1
<b>Excluding Missing Index Values (1<sup>st</sup> to 300<sup>th</sup> Priorities)</b>					
<i>Crashes</i>	<i>Crossings</i>	<i>Mean</i>	<i>Std Dev</i>	<i>Minimum</i>	<i>Maximum</i>
0	62	187.2	71.8	63	300
1	127	185.0	71.1	22	299
2	74	101.4	77.4	6	295
3	18	98.7	85.8	13	254
4	8	35.8	40.4	2	121
5	4	40.0	31.6	5	74
6	1	7.0	.	7	7
8	2	102.0	138.6	4	200
11	1	1.0	.	1	1

In an ideal prioritization method, the Priority value always decreases (i.e., priorities are higher) as the number of crashes increases. Due to the fact that missing index values appended to the list cannot be properly ranked, the lower part of Table 7-9 must be used to evaluate the method’s efficiency in prioritizing crossings with crash histories. The logical pattern is met. The mean Priority value decreases as the number of crashes increases, and the only crossing with 11 crashes was given 1<sup>st</sup> priority. The pattern is broken for 5 crashes, where the mean Priority is slightly greater (less priority on the

average) than for 4 crashes. The two crossings with 8 crashes received very different priorities primarily due to their AADT difference. 020871M has AADT=24,000 and received 4<sup>th</sup> priority. 598310X has AADT=270 and received 200<sup>th</sup> priority. Clearly, 598310X has significantly more crashes per vehicle and should have received higher priority, but this is mathematically impossible with any ranking formula conceptually similar to  $TPI_{rev}$ . Still, the method ensures that both crossings made the top priority list defined in step 1.

Table 7-10 presents the summary of priorities assigned to warranted passives, by number of warrants met. As in the previous results summarized in Table 7-9, the lower part of Table 7-10 must be used to evaluate the method's efficiency in prioritizing passive crossings by warrants met. The ideal method would show a steady decrease in the mean the priority rank as the number of warrants increases. This pattern was met only for 1 and 2 warrants, and missing index values change the priorities considerably.

Ranking the passive with the method discussed in Chapter 6 improves the compatibility between priorities and number of warrants met. Nevertheless, the alternative ranking method used to prepare these results put all passive crossings meeting the maximum number of warrants in the top priorities.

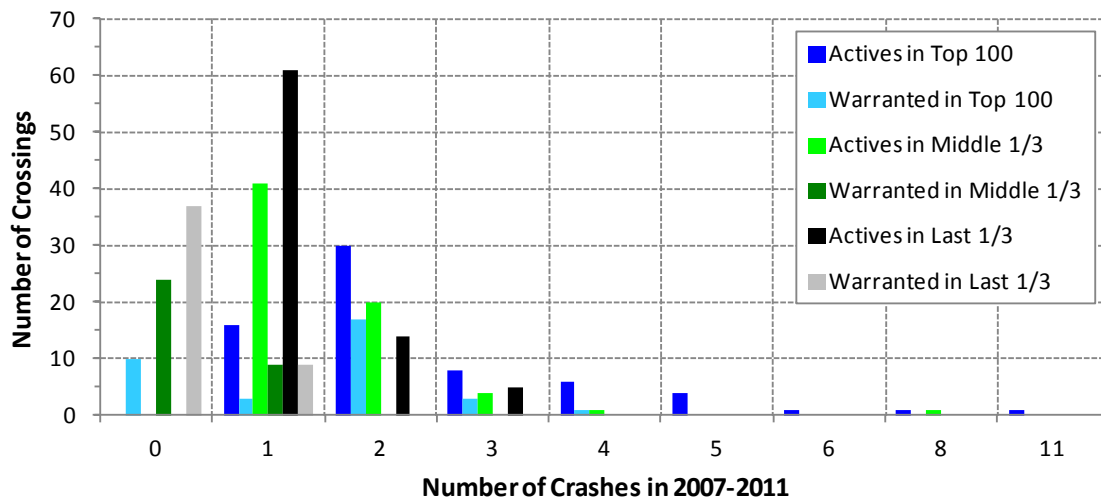
**Table 7-10 Summary of the Integrated Top Priorities by Number of Warrants Met**

Including Missing Index Values (1 <sup>st</sup> to 302 <sup>nd</sup> Priorities)					
<i>Warrants</i>	<i>Crossings</i>	<i>Mean</i>	<i>Std Dev</i>	<i>Minimum</i>	<i>Maximum</i>
1	11	47.7	9.5	33	60
2	6	117.7	142.8	21	302
3	78	208.0	75.3	9	302
4	18	76.5	29.4	3	108
Excluding Missing Index Values (1 <sup>st</sup> to 300 <sup>th</sup> Priorities)					
<i>Warrants</i>	<i>Crossings</i>	<i>Mean</i>	<i>Std Dev</i>	<i>Minimum</i>	<i>Maximum</i>
1	9	45.0	8.2	33	57
2	3	24.0	3.0	21	27
3	67	196.8	67.9	9	300
4	18	76.5	29.4	3	108

Table 7-11 and Figure 7-5 summarize the contents of the Top Priority List, showing the number of active and passive crossings in the top 1/3 (100 crossings), middle 1/3 and last 1/3 of the priority ranks, by number of crashes and by crossing type. The worst crossings in terms of number of crashes were all placed in the top 100 priorities, with the exception of the previously discussed active crossing with 8 crashes and very low AADT. The number of crossings with either none or few crashes increases as we progress priority down the list.

**Table 7-11 Summary of Top Priorities by Contents**

Crashes	Top 100			100 to 200			>200		
	Actives	Warranted	Total	Actives	Warranted	Total	Actives	Warranted	Total
0	0	10	10	0	24	24	0	37	37
1	16	3	19	41	9	50	61	9	70
2	30	17	47	20	0	20	14	0	14
3	8	3	11	4	0	4	5	0	5
4	6	1	7	1	0	1			
5	4	0	4						
6	1	0	1						
8	1	0	1	1	0	1			
11	1	0	1						
Total	67	34	101	67	33	100	80	46	126



**Figure 7-5 Top Priorities Contents by Number of Crashes**

**Summary of Conclusions and Recommendations**

*Prioritization methodologies that sort a list containing both active and passive crossings by  $TPI_{rev}$  will continue to place nearly all passives and very low-volume actives at the bottom of the list. Reasons are summarized below.*

- Favoring high-volume crossings is an intrinsic property of any priority index based on statistical models that consider AADT, due to the considerable difference in order of AADT magnitude between active and passive crossings, and the similar order of magnitude or categorical nature of the other variables.
- In Texas, there is another factor that further lowers the passive crossings' priorities in an overall ranking procedure based on  $TPI_{rev}$ . Historically, the five-year crashes/crossing rate is around 3.5 times higher for active crossings than for



passives. For yearly accidents, this difference is between 2 and 3. In terms of the integrated prioritization methodology, this further lowers passive crossings' priorities. [Figure 7-1](#) illustrated the impact of crashes on  $TPI_{rev}$ .

*The integrated prioritization methodology cannot overlook crossings with risk factors because they have no  $TPI_{rev}$  values due to lack of a data item.*

- There are 582 active crossings without  $TPI_{rev}$  values in the data used in this analysis. Of these, 9 had 1 crash and 5 had multiple crashes.
- There 83 warranted crossings in the same situation. Of these, 33 met multiple warrants and 4 had multiple crashes.

*An efficient integrated prioritization methodology must take full advantage of the warranting procedure developed in this project and, if possible, the procedure to rank passive crossings.*

- The warranting procedure described in [Chapter 5](#) is based on broad criteria designed to identify passive crossings with potential risk factors and eliminate from consideration those that are not inspection candidates. In the data used in this chapter, the warranting procedure eliminated about 70 percent of all passives, resulting in 1,115 warranted crossings.
- The preferred procedure to rank passive crossings was discussed in [Chapter 6](#) and includes the TPCI. However, if implementing two indices in TRIMS becomes impractical, the alternative procedure described in Step 3 of the recommended methodology gives good results.

*An efficient integrated prioritization methodology should minimize manual tasks, taking full advantage of the ranking procedure recommended in this chapter.*

- The only way to ensure that the top of the priority list balances active and warranted passive crossings and captures crossings with most risk factors is to prioritize them separately and build the priority list according to the recommended methodology.
- Implementation of the recommended methodology will streamline the process of prioritizing the nearly 10,000 open, public crossings in Texas for Section 130 funds allocation.

## REFERENCES

- 1 Aleskerov, F., and B. Monjardet. *Utility Maximization, Choice and Preference*. Heidelberg: Springer Verlag, 2002
- 2 American Association of State Highway Officials (AASHTO). *A Policy on Geometric Design of Highways and Streets*, 2004
- 3 American Association of State Highway Officials (AASHTO). *Highway Capacity Manual*. Chapter 17, Transportation Research Board, 2000.
- 4 Austin, R. and J. Carson. An Alternate Accident Prediction Model for Highway-rail Interfaces. *Accident Analysis and Prevention*, Vol. 34, No. 1, 2002.
- 5 Delaware Department of Transportation. 2011 Delaware Manual on Uniform Traffic Control Devices for Streets and Highways (DE MUTCD). Part 8. Available online at: <http://regulations.delaware.gov/register/july2011/final/mutcd/Part8.pdf>
- 6 Faghri, A. and M. J. Demetsky. *Evaluation of Methods for Predicting Rail-highway Crossing Hazards*. Virginia Highway & Transportation Research Council, 1986. HHTRC86-R32.
- 7 Florida Department of Transportation. *Rail Manual*. Topic No:725-080-002, March 2000.
- 8 German National Railroad Construction and Operation Regulations, Section 11, Railroad Crossings. Available online at: [http://www.gesetze-im-internet.de/ebo/\\_\\_\\_11.html](http://www.gesetze-im-internet.de/ebo/___11.html) (Eisenbahn-Bau und Betriebsordnung)
- 9 Hammond, J.S, R.L. Keeney, and H. Raiffa. *Smart Choices: A Practical Guide to Making Better Decisions*. Boston: Harvard Business School Press, 2002.
- 10 Idaho Department of Transportation. *Traffic Manual*, Section 853, July 2011.
- 11 Illinois Department of Transportation. *Bureau of Design and Environment Manual*. Chapter Seven: Railroad Coordination, 2010 Edition.
- 12 Johnson, Richard. *Miller & Freund's Probability and Statistics for Engineers*. 7th edition. Pearson Prentice Hall, Upper Saddle River, NJ, 2005
- 13 Klaver, Kelley. *Evaluation of Sight Distance as a Criterion for Prioritizing Rail-Highway Intersections in Texas*. Master of Science Thesis, Texas A&M University, December 1993.
- 14 Lalani, Nazir. *Improving Safety at Railroad-Highway Grade Crossings*. Presentation by Traffex Engineers Inc., n\_lalani@hotmail.com

- 15 Legifrance. Le Service Public de la Diffusion du Droit. Arrêté du 18 Mars 1991 Relatif au Classement, à la Réglementation et à l'Équipement des Passages à Niveau. Version Consolidée au 05 Juin 2008.
- 16 Ministro de Obras Públicas. Instrucción 3.1-IC Características Geométricas. Trazado, y la Norma complementaria. Available online at: [http://www.carreteros.org/normativa/trazado/3\\_1ic/apartados/anexo.htm](http://www.carreteros.org/normativa/trazado/3_1ic/apartados/anexo.htm), Orden Ministerial 27-Dec-1999, updated 28-Jul-2010.
- 17 National Safety Council. Estimating the Costs of Unintentional Injuries. Available online at: [http://www.nsc.org/news\\_resources/injury\\_and\\_death\\_statistics/Pages/EstimatingtheCostsofUnintentionalInjuries.aspx](http://www.nsc.org/news_resources/injury_and_death_statistics/Pages/EstimatingtheCostsofUnintentionalInjuries.aspx)
- 18 Niu, X. and K. Krieger. Statistical Modeling and Prediction of Highway-Railroad Grade Crossing Safety in Florida. Florida State University, Tallahassee, FL, Final Report, May 2005.
- 19 Qureshi, M., M. Virkler, K. Bernhardt, G. Spring, S. Avalokita, N. Yathapu, V. Chilukuri, T. King and K. Gibbons. Highway/Rail Crossing Project Selection. Report Number UTC R60, Center for Infrastructure Engineering Studies, University of Missouri – Rolla, Rolla, MO, November 2004.
- 20 Saaty, T.L. (1999). Decision Making for Leaders. The Analytic Hierarchy Process for Decisions in a Complex World. Pittsburgh, PA, RWS Publications, 1999/2000 Edition.
- 21 Saccomanno, Frank, et al. A Model for Evaluating Countermeasures at Highway-Rail Grade Crossings. Transportation Research Record: Journal of the Transportation Research Record, No. 1918. TRB, National Research Council, Washington, D.C., 2005, pp. 18-25.
- 22 Saccomanno, Frank, Liping Fu, Congming Ren, and Luis Miranda. Identifying Highway-Railway Grade Crossing Black Spots: Phase 1. Publication No. TP 14168E. Department of Civil Engineering, University of Waterloo for Transport Canada. Waterloo, Ontario, CN, August 2003. Available online at: <http://www.tc.gc.ca/eng/innovation/tdc-summary-14100-14168e-1353.htm>.
- 23 Schoppert W and Dan W Hoyt. Factors Influencing Safety at Highway-Rail Grade Crossings. Highway Research Board, National Research Council, 1968.
- 24 Service d'Études sur les Transports, les Routes et leurs Aménagements (Sétra). Amélioration de la Sécurité aux Passages à Niveau. Note d'information, 128, December 2008.

- 25 Spanish Government. Royal Decree 780/01. Available online at:  
[http://www.carreteros.org/legislaciona/transportes/rlott/otros/rd\\_780\\_01.htm](http://www.carreteros.org/legislaciona/transportes/rlott/otros/rd_780_01.htm) , Madrid,  
July 6 2001.
- 26 Stampley, B., Miller, B., Smith, R., and Scullion, T. Pavement Management Information System Concepts, Equations and Analysis Models. Texas Transportation Institute, Research Report TX 96/1989-1, August 1995.
- 27 Teknomo, Kardi. Analytic Hierarchy Process Tutorial. (2006). Available online at:  
<http://people.revoledu.com/kardi/tutorial/AHP>.
- 28 Texas Department of Transportation. Bridge Division. Bridge Inspection Manual. Chapter 7-2, Texas Eligible Bridge Selection System (TEBSS). July 2002.
- 29 Texas Department of Transportation. Rail Division. Texas Highway-Rail Grade Crossing Safety Action Plan. Austin, TX, August 2011
- 30 Transportation Research Board, National Research Council. Highway Capacity Manual. Washington, D.C., 2000.
- 31 Tranvia Portal. Ferropedia. Available online at:  
[http://ferrocarriles.wikia.com/wiki/Paso\\_a\\_nivel](http://ferrocarriles.wikia.com/wiki/Paso_a_nivel)
- 32 U.S. Department of Transportation. Federal Highway Administration. Highway/Rail Grade Crossing Technical Working Group (TWG). Guidance on Traffic Control Devices at Highway-Rail Grade Crossings, November 2002.
- 33 U.S. Department of Transportation. Federal Highway Administration. Railroad-Highway Grade Crossing Handbook, Revised Second Edition, Washington, DC, 2007.
- 34 U.S. Department of Transportation. Federal Highway Administration. Railroad-Highway Grade Crossing Handbook. Section 3: Assessment of Crossing Safety and Operation. Revised Second Edition, August 2007. Available online at:  
<[http://safety.fhwa.dot.gov/xings/com\\_roaduser/07010/sec03.htm#b](http://safety.fhwa.dot.gov/xings/com_roaduser/07010/sec03.htm#b)>
- 35 U.S. Department of Transportation. Federal Railroad Administration. Safety Data Website. Available online at:  
[http://safetydata.fra.dot.gov/OfficeofSafety/publicsite/on\\_the\\_fly\\_download.aspx](http://safetydata.fra.dot.gov/OfficeofSafety/publicsite/on_the_fly_download.aspx)
- 36 U.S. Department of Transportation. Federal Railroad Administration. Signal Related Speed Limits. CFR. 236.
- 37 Weissmann, Jose, R. Harrison, N.H.Burns and W.R.Hudson (1989). Selecting Rehabilitation and Replacement Bridge Projects. Extending the Life of Bridges, Lake Buena Vista, FL, USA, Published by ASTM. December 5, 1989.

- 38 Wimsatt, Andrew et al. Project 0-6386: Evaluation and Development of Pavement Scores, Performance Models and Needs Estimates. August 2011.

# Appendix 1

## Annotated Bibliography

This appendix contains the annotated bibliography as submitted in a technical memorandum.

---

To: Darin Kosmak  
From: TTI – Annie Protopapa, Srinivasa Sunkari, Steven Venglar, and Jeffery Warner  
Date: May 27, 2011  
Subject: 0-6642 Task 1 Technical Memorandum—Part 2: Literature Review  
Objective: Document literature associated with safety evaluation of highway-rail grade crossings.

---

---

### Content

---

Content .....	1
Introduction .....	1
Annotated Bibliography .....	1
Extraction of Warrants and Criteria for Highway-Rail Grade Crossings .....	85
Extraction of Accident Prediction Models and Indices .....	101

---

### Introduction

---

Task 1, scheduled to end on May 31, 2011, consists of two parts: literature review (TTI) and the research database (UTSA). This memo represents the review of literature undertaken by the TTI team. The following sections consist of an annotated bibliography of the documents reviewed for this task, along with extractions of the material within the literature review that specifically address warrants or criteria for grade crossings and accident prediction models or indices.

---

### Annotated Bibliography

---

The annotated bibliography section contains documents organized alphabetically, with each consisting of an overview or abstract and important information captured from that report.

**Overview/Abstract:**

The specific goal of this report is to present a comprehensive set of recommendations for changing practice at railway level crossings in Australia and New Zealand, based on a comprehensive review of the literature and relevant Internet sources. This includes material presented at the 7th International Symposium Highway-Railroad at Grade Crossings held at Monash University in February 2002, which had the theme “Getting Active at Passive Crossings.” It attracted leading researchers and administrators from North America and Europe, as well as from Australia and New Zealand, and presented an up to date overview of many of the issues relevant to the present document.

**Captured Information:**

**4.3 Harmonization Of Standards**

Current warrants for Stop signs and upgrading to flashing light treatments for all Australian jurisdictions and New Zealand are shown in Appendix A. It is apparent that there is substantial agreement on the Stop sign warrants.

It is appropriate to discuss warrants for active protection in the context of passive crossings as these warrants represent the limits for passive crossings in terms of rail and road traffic. All Australian jurisdictions base their warrant for active protection on a criterion based on the weekly number of trains multiplied by the daily number of vehicles, making some allowance for risk factors such as crossing geometry. Western Australia and Tasmania have similar criteria. Criteria in New South Wales appear to be generally similar, with much higher thresholds approximately 3 to 3.5 times higher than Western Australia and Tasmania. South Australia has slightly higher criteria again, approximately 1.2 to 1.4 times greater than New South Wales. Queensland has generally similar numerical criterion to New South Wales, but this is embedded in a comprehensive system for assessing risk factors (see below).

Because of the considerable differences between jurisdictions in operating conditions and the number of open crossings, there appears to be little prospect of achieving closer agreement on warrants.

**4.4 Managing Risks at Passive Level Crossings**

Queensland has developed a comprehensive system for assessing risks at railway level crossings and for assessing the likely impact of different treatments on these risks. The Risk Based Scoring System (RBSS) is a system which applies to all crossings, active and passive, and one of its primary applications has been to identify and prioritise crossings for conversion to active treatment. Nevertheless, it is suitable as a tool for deciding on upgrades to passive crossings which do not involve upgrading to active treatment.

The essential components of the system are:

- Twenty-nine risk factors.
- Nineteen possible accident mechanisms.
- Thirty-eight possible treatments.

Risk assessment for a crossing involves examining the matrix formed by the risk factors and the possible accident mechanism. If a risk factor is present, its potential influence on each of the risk factors is assessed and a numerical score reflecting this risk is allocated. The risk assessment consists of not only a total score (the sum of all the cell entries), but a score for each of the risk factors, and a score for each of the possible accident mechanisms. In most cases, there will be a small number of risk factors and accident mechanisms, giving a clear indication of where the sources of risk lie and how they are likely to contribute to crashes. Assessing the value of each of the possible treatments follows a similar process. A matrix is formed, this time by the possible treatments and the accident mechanisms. The likely effect of each of the possible treatments on the main accident types is considered, and a numerical score given which reflects the impact that treatment is likely to have on each particular accident mechanism. Following a procedure such as the RBSS will reduce the instances where ineffectual treatments to deal with railway level crossings are chosen, and may allow the identification of low-cost packages of treatments which are likely to be effective in reducing risk. One of the strengths of the RBSS is that it does allow systematic comparison of different treatments and combinations of treatments in terms of the impact they have on the more salient crash mechanisms in each particular situation.



## 14 Appendix A: Comparison of Warrants for Level Crossing Protection – Australia and New Zealand

JURISDICTION	Western Australia	Queensland	New South Wales	Tasmania	South Australia	New Zealand
Responsibility	Assessment by MRWA – jointly by Rail authority and MRWA. MRWA funds improvements on public roads and shares maintenance costs with Rail Authority Removing visibility impediments – local government and rail authority.	Main Road Queensland determine warrants –	Rail Authority responsible for - installing & maintaining signs, signals, booms etc & maintaining road to edge of sleepers. RTA installs signs and markings on approaches on major roads. LG on local roads. LG is responsible for street lighting. RTA & Rail Auth jointly determine protection needs. RTA funds ALL work on State & Regional roads. On local roads RTA funds 2/3	Level Crossing Warning Committee (LCWC) determines level of protection required. Rail authority to provide position signs and maintain clear visibility in rail reserve. road authority the rest of the visibility triangles. DIER Tasmania responsible for advance signs and road markings on all roads. LCWC raise sightline issues on private property/road reserves with road owner.	Transport SA funding and assessment. Criteria determined by State Level Crossing Safety Committee Removing visibility impediments – local government and rail authority.	Responsibility for regulating protection standards at level crossings rests with the Land Transport Safety Authority. There is a statutory requirement to consult with operators and other stakeholders.
Position Signs	Max of 80km/h train speed Visibility triangles 5 seconds safety margin 3 seconds reaction time plus addition of 0.5seconds if – - less than 2 trains per day - poor road conditions Other safety considerations – stacking, train horn, lighting, train headlights where pedestrians	Visibility triangles 5 metre safety margin Reaction time 2.5 seconds	Visibility triangles, 5 seconds safety margin. Reaction time 2.5 seconds.	Visibility triangles and 5m clearance per NSW & Qld No new crossings with angles less than 35 degrees left and 30 degrees right. Reaction time 2.5 seconds Safety margin 5m clearance	Minimum angle (35 left, 30 right) Visibility triangles 2.5 seconds reaction time	Visibility triangles, 65m visibility required on roads with operating speeds 60 km/h or less. 120m visibility required in all other locations

JURISDICTION	Western Australia	Queensland	New South Wales	Tasmania	South Australia	New Zealand
Stop Signs	Max train speed 100km/h Visibility triangles 5 second safety margin Other safety considerations – stacking, train horn, lighting, train headlights where pedestrians	Visibility triangles 5 metres safety clearance margin	Visibility triangles, 5 seconds safety margin.	Visibility triangles 5 metres safety clearance margin	Failure to satisfy position signs Visibility triangles 6metre safety margin Minimum angle (as per all States)	When sight distance along the railway from the road approach is so restricted that the safe approach speed is 20 km/h or less, Stop control is warranted. This may not apply at crossings with high volumes of heavy or long vehicles (eg B doubles).
Flashing Lights	Failure to meet visibility for stops and can't be improved. Conflict (weighted to account for high speed trains and vehicles) > 14,000 (trains per week x AADT) Benefit/cost considerations (>2) Not withstanding conflict - may be installed because important road – eg highway. Other safety considerations as above plus road must be sealed for 50m each side, advance amber warning lights may be used for road trains etc	Failure to meet visibility for stops and can't be improved. Conflict (vehicles per day x trains per week) single track – Urban areas 300,000 Rural areas 50,000 Benefit/cost analysis support required	Failure to meet visibility for stops and can't be improved. Need for Flashing Lights is based on Conflict number (weekly trains x daily traffic) based on road speed and number of tracks – Single track 60k zone – 50,000 Single track 100k zone – 45,000 Multiple track 60k zone - 80,000 Multiple track 100k zone – 70,000	Conditions for Stop signs are not met or conflict > 14,000 single track or >12,000 multiple track. Or crossing on highways or main arterial roads, or situations where special safety problem, eg shunting - each case considered on its merits.	Failure to meet visibility for stops and can't be improved. Conflict > 70,000 for single lines and > 60,000 for multiple lines Benefit/cost considerations (>2) Consideration of special situations such as shunting Gongs/bells with every FL May use normal intersection signals where crossing next to road traffic light intersection (see below) May use overhead signals	Failure to meet visibility for stop signs and can't be improved. Conflict > 70,000 for single lines and > 60,000 for multiple lines Benefit/cost considerations (>2) Consideration of special situations such as shunting Gongs/bells with every FL May use normal intersection signals where crossing next to road traffic light intersection (see below) May use overhead signals
Pedestrian Protection	Mazes, paths, bells, signs	No specific mention of pedestrian treatments	Based on AS1742.7 and experience. Paths, mazes, bells and pedestrian booms as required	Improvements – paths, bell/gongs mazes per AS 1742.7	Mazes, paths for pedestrians	Footways with fencing, signage, pedestrian stop line should be marked at a distance of three metres from the nearest rail to indicate a safe position for pedestrians to wait for the passage of trains, mazes.

---

**Florida Department of Transportation. *Rail Manual*. Topic No. 725-080-002, March 2000.**

---

**Overview/Abstract:**

The purpose of this Florida DOT manual is to identify rail, intermodal, and seaport processes, procedures, guidelines, and responsibilities for the development and management of transportation projects in the State of Florida. Chapter 1 discusses the highway railroad grade crossing improvement program in the state. Appendix B contains information related to the program prioritization, of which includes equations and methods utilized.

---

**Illinois DOT. “Chapter Seven Railroad Coordination.” *Bureau of Design and Environment Manual – 2010 Edition*.**

---

**Overview/Abstract:**

The Bureau of Design and Environment Manual has been prepared to provide uniform practices for the Department and consultant personnel preparing Phase I studies and reports and contract plans for Department projects. The Manual presents most of the information normally required in the development of a typical roadway project. The designer should attempt to meet all criteria and practices presented in the Manual; however, the Manual should not be considered a standard that must be met regardless of impacts. The designer should develop roadway designs that meet the Department’s operational and safety requirements while preserving the aesthetic, historic, or cultural resources of an area. Designers must exercise good judgment on individual projects and, frequently, they must be innovative in their approach to roadway design. This may require, for example, additional research into the highway literature. Chapter 7 of the manual addresses Railroad Coordination, which includes methodology in selecting warning devices at highway-rail grade crossings.

---

**Klaver, Kelley. *Evaluation of Sight Distance as a Criterion for Prioritizing Rail-Highway Intersections in Texas – A Thesis*. Master of Science. Texas A&M University, December 1993.**

---

**Overview/Abstract:**

The objective of this research was to evaluate sight distances as a criterion for prioritizing rail-highway intersections in Texas to help distinguish between the crossings with similar or identical priority index numbers. Accident and sight distance data were compiled and analyzed. A sight distance variable was incorporated into the current Texas Priority Index and evaluated for its effects on the overall ranking of the rail-highway intersections. A state hazard index was chosen from a state-of-the-practice review with which to compare the current and revised Texas Priority Indices. Finally, the effectiveness of each of the indices was predicted in terms of the distribution of priority index numbers and their ability to move the most potentially hazardous crossings up on the rankings.

It was concluded from the accident analysis that sight distance contributed to more vehicle-train accidents than any other factor. Further, improvements to warning devices at passive crossings would effectively reduce the overall sight obstruction, reduce the number of train involved accidents at rail-highway intersections.

### **Captured Information:**

## **CHAPTER II BACKGROUND**

Before sight distance can be evaluated for its influence on the prioritization of rail-highway intersections in Texas, a foundation needs to be set for the importance of sight distance as a design characteristic.

### **Accidents at Rail-Highway Intersections**

There are numerous factors that contribute to accidents at rail-highway intersections, and some, such as human behavior, are almost impossible to quantify. It is therefore, exceptionally difficult to predict where and how many accidents -are going to occur at any rail-highway intersection. This difficulty has been shown in the development of many accident prediction formulas as design factors, including sight distance, have not been shown to be strong indicator variables (8). The examination of accident reports along with a field study of the intersections where accidents occurred, however, can indicate possible contributing factors to the accidents.

A study was conducted by Berg, Knoblach, and Hucke (9) in 1982 to investigate crossing sites in North Carolina and Wisconsin that had experienced one or more accidents and to list the principal factors that were believed to have contributed to the occurrence of each accident. The analysis hypothesis was that the occurrence of a vehicle-train accident was the result of a recognition, decision, or action error.

The findings of the study revealed that about 80 percent of the accidents investigated at crossings with crossbucks involved errors of driver recognition and about 23 percent involved -late recognition of a train that was already in the crossing. The principal contributing factors to vehicle-train accidents at crossings were identified as the lack of quadrant sight distance and low driver expectancy of train presence. The principal contributing factor for those accidents that involved a train already in the crossing was limited sight distance due to darkness or roadway approaches whose alignment restricted visibility of the crossing from the approach. Further, about 38 percent of the accidents investigated at crossings with flashing lights involved driver recognition errors. Of these accidents, 81 percent of the drivers did not detect the signal when they were on the approach.

Another recognition error was inadequate track sight distance available to drivers of large trucks that had stopped at the crossing. Although sight distance restrictions may not be predictive of the number of accidents likely to occur at a crossing, a lack of sight distance at rail-highway intersections can be considered a potential hazard as shown by Berg, Knoblach, and Hucke (9). Their study supports the hypothesis that sight distance is crucial at rail-highway intersections, and that a lack of sufficient sight distance can, in some cases, be linked to the occurrence of accidents.

## Priority/Hazard Indices

Along with the requirement for the states to rank crossings to allocate funds for improvements came the development of many hazard indices and accident prediction formulas. It is the responsibility of each of the states to choose an existing prioritization system or develop their own. Over the years, numerous attempts have been made to develop improved systems for ranking crossings. This section presents the Texas Priority Index, commonly used hazard indices, a review of the current systems used by several of the states, and a review of several studies to develop/improve methods of prioritizing rail-highway intersections.

### *Texas Priority Index*

The current formula used by the Texas Department of Transportation is known as the Texas Priority Index (Equation 4). It includes variables for vehicle and train volume, train speed, protection type, and five-year accident history.

$$\text{Texas Priority Index} = \frac{ADT * T * T_s * PT * ACC^{1.15}}{1,000} \quad [4]$$

- where: ADT = average daily traffic;  
T = average daily train traffic;  
T<sub>s</sub> = track speed limit, miles per hour;  
PT = variable for type of protection; equal to 0.2 for gates, 0.5 for cantilever lights, 0.75 for masts, and 1.0 for crossbucks; and  
ACC = five-year train involved accident history; if no accidents occurred, accidents equal 1; multiplied index by 1.15 when 0 or 1 accident.

Where there are switching trains or multiple mainline tracks, a priority index is calculated for each track and then added together for the priority of the crossing.

With regard to the Texas Priority Index, the exposure values give groups of moderate to low exposure crossings equivalent or nearly equivalent index numbers which are placed in order of decreasing exposure and, therefore, potential hazard. To accurately differentiate between these clusters in terms of the individual crossings' needs for improvement, a better distribution of the index numbers is needed. The inclusion of sight distance in the Texas Priority Index could provide a wider range of possible index numbers had a more accurate idea of which crossings may be more in need of improvement.

### *Review of State Hazard Index –Questionnaire*

*State 5.* State 5's ranking system is two-fold. All crossings in the state are ranked based on exposure, protection and accidents. Then, two- to three-times the number of crossings that can be funded for improvements are chosen and inspected in the field. Sight distance is estimated, and the crossings are ranked with the Investigative Index which includes a sight distance factor. The sight distance factor is based on the judgment of the engineer and is given a rank of 0 to 4 based on the available sight distance: adequate, above average,

average, below average, or poor, respectively. This rank of 0 to 4 is then multiplied by 16 and added to the formula which includes factors such as protective type, exposure, accidents and train speed (Equation 12).

$$I. I. = \frac{PF * ADT * T * TSF * TF}{160} + (70 * \frac{A}{Y})^2 + (SDF*16) \quad [12]$$

where:

- II. = Investigative Index;
- PF = protection factor;
- ADT = average daily traffic;
- T = average daily train traffic;
- TSF = train speed factor;
- TF = track factor;
- A/Y = accidents per year; and
- SDF = sight distance factor.

*State 6.* State 6 calculates a hazard index based on three multiplicative factors: ADT, average daily train traffic, and an additional factor which is the sum of ten elements (maximum value of 12.2). The hazard index is then multiplied by a relative hazard factor based on protection type to obtain an adjusted hazard index (Equation 13). The elements included in the additional factor are: number of tracks, track movements, crossing angle, grades, alignment, number of roadway lanes, sight distance, vertical sight distance, crossing width, and local interference. The sight distance element has a maximum value of 4.0.

Each quadrant is given a value of 1.0 to 0.0 which varies from totally restricted sight distance to unlimited sight distance. Crossing features such as width, crossing angle, highway alignment and approach grades are four of the ten additive factors and are given maximum values of 0.8, 1.6,

$$Hazard\ Index\ (HI) = \frac{ADT * T * (F_1 + F_2 + F_3 \dots F_{10})}{100} \quad [13]$$

$$Adjusted\ Hazard\ Index = HI * RHF$$

where:

- ADT = average daily traffic;
- T = average daily train traffic;
- F<sub>1</sub>..F<sub>10</sub> = various factors; and
- RHF = relative hazard factor.

0.6, and 0.2, respectively.

*State 7.* State 7's index is based on a score of 100, with a lower score indicating a safer crossing. Points are added for various substandard crossing characteristics and features. The sight distance factor used by State 7 is 15percent of the overall score of a crossing. The score is based on the number of quadrants with available sight distance; the score increases with the number of restricted quadrants. Other-factors include: alignment, grades, surface, skew of crossing, nearby

intersection, advanced warning signs, lighting, and type of trains (15 percent); surface type (15 percent); priority of crossing as set by various officials (35 percent); and accident potential which is based on exposure, train movements, pavement/no pavement, train speed, number of highway lanes, and highway type (20).

*State 8.* The Hazard Index used by State 8 is a two part equation (Equation 14). The first part is a relationship of the exposure factors, and the second part is a relationship of the quadrant sight distance. The Traffic Index (TI) is the major component of this Hazard Index, and it is determined by the product of the ADT, vehicle speed, average daily train traffic and the maximum allowable train speed. The sight distance factor or percent obstruction is found by subtracting the available quadrant sight distance from the required quadrant sight distance and dividing this number by the required sight distance. Although not stated, it was assumed that if the available sight distance was equal to or greater than the required sight distance, the hazard index was equal to the traffic index. The percent obstruction is multiplied by the TI and then added to the TI to obtain the Hazard Index. The sight distance factor used by State 8 has a very significant effect on the ranking of the crossings as the priority index can double if one quadrant is completely blocked.

$$\begin{aligned}
 \text{Traffic Index Factor (TI)} &= \frac{T * TS * ADT * VS}{10,000} \\
 \text{Sight Distance Factor (PO)} &= \frac{\text{Sight Distance Obstruction}}{\text{Required Sight Distance}} \\
 \text{Hazard Index (HI)} &= TI + (PO * TI)
 \end{aligned}
 \tag{14}$$

where:

- T = average daily train traffic;
- TS = train speed;
- ADT = average daily traffic;
- VS = vehicle speed; and
- PO = percent obstruction.

Each state reported that the sight distance variable used in its index was moderately significant or significant to the overall rank of the crossings with respect to other variables in the formula. Sight distance, therefore, can be effectively used in a hazard index in many different ways.

#### ***Attempts to Improve Method of Prioritization***

Although most of the hazard indices discussed above have been used for years, continuous efforts are being made to improve the prioritization of rail-highway intersections. These efforts are being made to recognize the potential hazard at rail-highway intersections, allocate money in an optimum manner, and increase safety at these intersections.

*Coburn.* A 1969 study by Coburn (11) was conducted to-compile data for use in the education of drivers and to derive a formula for computing an absolute hazard index (accident prediction

formula) for rail-highway intersections. Variables in rail-highway accidents as related to the driver, vehicle class, and geometric features were compared and correlation and regression analysis was used to determine the relationship of thirteen variables to accident occurrence. The research hypotheses were that vehicle speed and frequency, train speed and frequency, and geometric features had an effect on the accident rate at grade crossings.

Thirteen variables were tested for significance in the .model at the 0.05 significance level. The thirteen variables included: exposure, roadway type, highway width, surface type, angle of intersection, posted speed limit, number of tracks, crossing slope, approach slope, quadrant sight distance, approach sight distance, type of protective device and number of intersecting roads and streets. Multiple regression and correlation analysis were used and the variables were eliminated one by one in order of the least non-significant t-value. Results showed that the exposure and type of protective device were the only two variables that were statistically significant at the 5 percent level, and therefore, the only factors that were useful in the accident prediction equation.

*Mengert.* A study was conducted by Mengert (12) in 1980 to distinguish between, develop, and evaluate relative hazard index formulas for ranking crossings according to relative hazard. Also, absolute hazard index formulas were evaluated for their ability to provide an estimate equal to, or at least proportional to, the expected accident frequency at individual crossings. The research approach included the measurement of the efficacy of a hazard index for the relative ranking of crossings. Also, linear regression analysis was used to develop new hazard indices which included non-volume variables such as highway surface type, number of main tracks, and functional classification of the roadway.

Several conclusions of the study were: simple volume-dependent formulas appear to have 90 to 95 percent of the predictive capability of more complex formulas; however the new hazard formulas developed in the research were more selective than the New Hampshire formula (in certain respects), even though the difference may not be considered large enough in certain applications to forgo the simplicity of the New Hampshire formula. In other words, exposure contributes to about 90 to 95 percent of the hazard of rail-highway intersections; however, the use of other engineering variables can further distinguish between the crossings in terms of potential hazards.

## **CHAPTER I11**

### **STUDY DESIGN**

Intuitively, adequate sight distance is required at an intersection to ensure safety. A strong foundation would be set for the necessity of a sight distance variable in the Texas Priority Index if accidents which have occurred at Texas rail-highway intersections could be linked to sight distance restrictions. Further, if the sight distance variable were to help distinguish between the remaining moderate exposure crossings in terms of potential hazard by providing a better distribution of the crossings, a sight distance variable should be included in the index. This chapter defines the selection of study sites, the collection of data, the procedures used, and the method of analysis for this thesis.



### **Accident Analysis Methodology**

Accidents occurring at rail-highway intersections can be an indication of a problem with the design or condition of the intersection. Reports of accidents at crossings in the six counties selected for study were obtained from the Texas Department of Transportation. The accident reports total 126, between January 1988 and July 1993. The accident analysis was divided into six steps:

1. Divide accidents into train involved and non-train accidents;
2. List contributing factors into train involved and non-train accidents;
3. Group contributing factors into primary contributing factors;
4. Compare accidents to type of protection;
5. Compare accidents to sight distance restrictions; and
6. Determine severity of train involved and non-train accidents.

### **Field Data Analysis Methodology**

The field data analysis methodology was divided into five steps:

1. Code the rail-highway intersections according to degree of sight distance obstruction;
2. Calculate the current Texas Priority Index and Investigative Index;
3. Revise the Texas Priority Index;
4. Determine the effect of sight distance on the Texas Priority Index; and
5. Predict the effectiveness of the priority indices.

### ***Calculate Current Texas Priority Index and Investigative Index***

With use of the data from the Texas inventory, the current Texas Priority Index was easily calculated (Equation 4).

$$\text{Texas Priority Index} = \frac{ADT * T * T_s * PT * ACC^{1.15}}{1,000} \quad [4]$$

Next, from the returned state questionnaires regarding current prioritizing methods, the State 6 priority index was chosen which makes use of the same variables as the Texas Priority Index (in a different manner) and also includes variables for sight distance and the number of tracks (Equation 12). The model chosen will be referred to as it is known, the Investigative Index. For this study, ideal track conditions (one main track) will be assumed. This assumption is made because the Texas Priority Index does not consider the number of tracks at a crossing as an additional variable, and thus, the Texas Priority Index and Investigative Index will be compared more effectively without the influence of the track variable.

$$I.I. = \frac{PF * ADT * T * T_s * TF}{160} + (70 * \frac{A}{Y})^2 + (SDF * 16) \quad [12]$$

As discussed in the background review, the sight distance factor in the Investigative Index is based on a scale of 0 to 4; a score of 0, 1, 2, 3, or 4 is assigned for good sight distance, above average sight distance, average sight distance, below average sight distance or poor sight distance, respectively and is a judgment call by the field engineer. In actual use, the engineers relying on the Investigative Index take school buses, hazardous material carriers and passenger trains into account by increasing the ADT. Further, only those accidents that could have been prevented by traffic engineering methods are entered into the formula. (Accidents occurring from driver error or accidents unrelated to crossing conditions are not considered). For this research, the ADT will consist only of the number of vehicles actually crossing the intersection per day, and the accidents entered into the formula will be the five-year train involved accident history (excluding the human error accidents) divided by five.

### ***Revise Texas Priority Index***

The next step in the field data analysis was to revise the Texas Priority Index by incorporating a sight distance variable into the formula. It was desired that the method/methods of sight distance incorporation produce a range of sight distance values to use in the current formula to help redistribute the index

Two methods of incorporating sight distance into the Texas Priority Index were developed. The development of the methods was based on a review of sight distance variables in the state priority indices and the assumed sight distance levels of importance used for the sight distance coding factor. A review of the state hazard indices with sight distance variables revealed that the majority of the applications were multiplicative and increased the index by approximately 1.5 for the worst case sight distance obstruction. One of the state's sight distance variables doubled the index for a totally obstructed quadrant, and another state's sight distance variable tripled the index for two or more obstructions.

There was one state that used sight distance as an additive factor (Investigative Index). A review of the weight given to this additive sight distance variable revealed that the influence of the variable on the index number of a crossing varied with the exposure and accident history. For example, the sight distance factor had more influence on low-volume crossings with no accidents than on high volume crossings. As the volume and accidents at a crossing increased, the effect of the sight distance variable decreased. Index numbers for high volume and low volume crossings were increased by the same amount (for the same sight obstruction); proportionally, however, low volume crossings were increased much more than high volume crossings.

This weighting effect of an additive sight distance variable is different from multiplicative variables. A multiplicative variable increases the index proportionably with increasing volume and accidents. Therefore, index numbers for high volume crossings were increased more (but in proportion to the exposure) than low volume crossings with the same sight distance obstruction. Because high volume crossings are more hazardous than low volume crossings, it is important that the sight distance variable increase the index proportionally. Thus, a multiplicative sight distance variable was chosen for the revised Texas Priority Indices.

From this review and the sight distance levels of importance (track sight distance being more critical than quadrant sight distance, and quadrant sight distance being more critical than

approach sight distance) two methods of including sight distance in the Texas Priority Index were developed. The first method was based on the sight distance coding factor: 0.3 was added for each track obstruction, 0.2 was added for each quadrant obstruction, and 0.1 was added for each approach obstruction. This total was added to 1.0 and multiplied by the current formula. The sight distance variable values ranged from 1.0 to 3.2 for a total of 23 different possible values (Table 3).

**Table 3. Revised Texas Priority Index--Method 1 Sight Distance Variables**

Number of Track Obstructions	Number of Quadrant Obstructions				
	0	1	2	3	4
0	1.0	1.2	1.4	1.6	1.8
1	1.3	1.5	1.7	1.9	2.1
2	1.6	1.8	2.0	2.2	2.4
3	1.9	2.1	2.3	2.5	2.7
4	2.2	2.4	2.6	2.8	3.0

Add 0.1 for each obstructed approach

Method 2 was developed similar to Method 1, but differed slightly. Instead of a value given for each of the ten sight distances measured, a value was given for each quadrant. The value for each quadrant could be one of three values: 0.25 for a track and quadrant obstruction, 0.15 for a track obstruction only, or 0.10 for a quadrant obstruction. The total for the four quadrants was added to 1.0 and multiplied by the current formula. The sight distance variable values ranged from 1.0 to 2.0 for a total of 18 different possible values (Table 4).

**Table 4. Revised Texas Priority Index--Method 2 Sight Distance Variables**

Number of Track Obstructions	Number of Quadrant Obstructions				
	0	1	2	3	4
0	1.00	1.10	1.20	1.30	1.40
1	1.15	1.25	1.35	1.45	1.55
2	1.30	1.40	1.50	1.60	1.70
3	1.45	1.55	1.65	1.75	1.85
4	1.60	1.70	1.80	1.90	2.00

Finally, after the development of the sight distance variables, it was important to ensure that a wide distribution of sight distance values was being produced for the crossings. To get a better distribution of the index numbers after the incorporation of a sight distance variable, it was important that a large majority of the crossing index numbers would not be multiplied by the same variable. Thus, a frequency analysis of the sight distance values was performed to ensure that the values were well divided among the crossings.

*Determine the Effect of Sight Distance on the Tam Priority Index*

After a sight distance variable was incorporated into the Texas Priority Index, it was necessary to determine the effect the variable had on the individual priority numbers, the respective

intersection's position within the overall rank, and the distribution of the index numbers. Three steps were followed to determine the effects of sight distance on the current index:

1. Assess the change in the overall rank order of the crossings;
2. Evaluate the redistribution of the passive crossings; and
3. Examine the overall redistribution of the individual index numbers.

**Determine Correlation Between Priority Indices.** In order to determine the relative effects of each of the indices on the rank order of the crossings, two methods of rank order correlation analysis were performed on the resultant ranks: Spearman's rank order correlation and Kendall's test of concordance. A computer software statistical analysis program was used to determine both coefficients as adjustments to the basic equations are necessary when ties exist among or between ranks.

The ordinary correlation coefficient calculated with linear regression analysis assesses the linear association between two variables. The variables in this study were the rank orders produced by the two priority indices being compared. Because the priority indices produce a ranking of the crossing, a rank correlation coefficient which measures the monotonic association between the variables was used. The correlation based on the ranks is referred to as Spearman's rank order correlation coefficient,  $r_s$ , (Equation 15), which is simply an ordinary correlation coefficient calculated on ranks (13).

$$r_s = \frac{S_{xy}}{\sqrt{S_{xi} * S_{yi}}} \quad [15]$$

where:

- $r_s$  = Spearman's rank order correlation coefficient;
- $S_{xi}$  = total sum of squares of rank, minus mean of rank numbers, for original index;
- $S_{yi}$  = total sum of squares of rank, minus mean of rank numbers, for revised index; and
- $S_{xy}$  = total sum of rank, minus mean of rank numbers, for original index multiplied by the total sum of rank, minus mean of rank numbers, for revised index.

The resulting rank order correlation coefficient lies between -1.0 and 1.0 and defines the degree to which the ranks are correlated with one another. A correlation coefficient of 1.0 represents positive correlation whereas a -1.0 represents total disagreement between the ranks. A zero correlation coefficient represents an intermediate condition or no particular connection between the ranks (14).

Secondly, a different approach was taken to determine the agreement between the ranks. The tau,  $\tau$ , coefficient given by Kendall (15) depends only on the number of order inversions for pairs of crossings in the two rankings (Equation 16).

$$\tau = 1 - \frac{2(\text{number of inversions})}{\text{number of pairs of crossings}} \quad [16]$$

If two rankings agree (show no inversion) for as many pairs as they disagree (show inversion), the tendency for the two rank orders to agree or disagree should be exactly zero. The interpretation of the obtained value of  $r$  is quite straight forward: if a pair of hazard index numbers is chosen at random from among those ranked, the probability that these two numbers would show the same relative order in both ranks is  $r$  more than the probability that they would show different order.

A difference in correlation between the revised indices and/or the Investigative Index and the current Texas Priority Index may or may not be desired. The current Texas Priority Index ranks the crossings in order of decreasing exposure and thus potential hazard. Because the majority of the potential hazard at rail-highway intersections is due to the exposure values, a drastic change in rank order is probably not desired. What is desired is an enhancement of the rank order in terms of more index numbers that cover a wider range. The crossings should remain in a similar order after the addition of a sight distance variable (or any other variable) with the exception of the poor sight distance crossings which should "jump up" in rank order. The question as to how much the sight restricted crossings should rise in rank order is a difficult one to answer. Sound engineering judgment is needed to determine if and when a sight distance variable has too much weight relative to the exposure values. A negative correlation between the current and revised indices would most likely indicate that too much weight was given to the sight distance variable.

*Redistribution of Passive Crossings.* One way of ensuring that no major change is taking place in the ranks is to examine the distribution of the crossings by protection type among each of the four indices. Since the crossings with the worst sight obstructions are passive crossings, these crossings should be moving up in rank order while active crossings should be moving down in rank order. Too much movement could be an indication that the sight distance variable as given too much weight while little or no movement could indicate that sight distance was not given enough weight.

*Redistribution of Index Numbers.* A frequency analysis was performed on the current and revised Texas Priority Indices to determine if the index numbers were better distributed. A wider range of index numbers and less ties between crossings would represent a wider distribution of the crossings and, thus, a better indication of which crossings are most in need of improvement.

### ***Predict Effectiveness of Priority Indices***

It was desired to predict which, if any, of the priority indices examined in this research was the most effective in locating potentially hazardous rail-highway intersections based on exposure, accidents, sight distance, and protection type. Thus, five steps were followed:

1. Evaluate redistribution of the sight distance coding factors;
2. Examine the 40 worst sight distance crossings;
3. Examine the middle third of the priority rankings;
4. Check the weight given to the sight distance variable; and

5. Compare the revised Texas Priority Indices to the Investigative Index.

*Redistribution of Sight Distance Coding Factors.* The coding factors (0 through 22) were divided into groups which were defined relative to each other: 0, 1-3, 4-6, 7-9, 10-12, 13-15, and 16-22 representing excellent, good, above average, average, below average, poor, and unacceptable sight distance, respectively. The distribution of the coding factors throughout the four indices was examined to determine if the crossings with poor sight distance were rising in rank. The priority index with the most sight restricted crossings located near the top of the rank was expected to be an effective priority index in terms of location of crossings with sight distance obstructions.

*40 Worst Sight Distance Crossings.* The distribution of the 40 crossings with sight distance coding factors greater than nine (below average, poor, and unacceptable sight distance) was examined to determine how much the crossings were rising in rank as a result of incorporating a sight distance variable.

*Redistribution of Middle Third of Rank.* With the revision of the Texas Priority Index, the major concern is the redistribution of the crossings towards the middle of the rank with moderate exposure values and similar priority index numbers. Therefore, to try and distinguish between the effectiveness of the revised indices and the Investigative Index, an examination of the distribution of the sight restricted crossings (sight distance coding factor greater than five) located in the middle third of the rank was performed to determine what was occurring within the Texas Priority Index before and after the sight distance variable.

*Weight Given to Sight Distance Viable.* It is important to note that it would not be desirable for an index to rank low volume crossings with restricted sight distance above high volume crossings with unrestricted sight distance. A balance between the two factors must be obtained because exposure has been shown to be the most important factor in assessing the potential hazard of a crossing, and it would not be just to give sight distance too much weight in the index formula. Therefore, the indices were examined to ensure that the high volume crossings were getting priority over very low volume crossings and that the sight distance variables were not the driving force behind the priority given to individual crossings revised index was compared directly to the Investigative Index to determine the major differences between the ranks and what factors were causing the differences.

## **CHAPTER IV RESULTS**

This chapter presents the results of the analyses conducted to evaluate sight distance as a criterion for prioritizing rail-highway intersections in Texas. The following sections document the analytical results of the field data, accident data, correlation of priority rankings, influence of a sight distance variable on the Texas Priority Index, and the priority index effectiveness.

### **Results of Field Data Collection and Analysis**

Results of the field data analysis are presented in the following sections:

1. Coded rail-highway intersections;

2. Calculated Texas Priority Index and Investigative Index;
3. Revised Texas Priority Indices;
4. Effect of sight distance on the Texas Priority Index; and
5. Effectiveness of priority indices.

### ***Coded Rail-Highway Intersections***

The first step in the field data analysis was to code the rail-highway intersections according to the degree of sight distance obstruction. As discussed in Chapter 3, each crossing was evaluated and assigned a number of 0 through 22, with 0 representing no sight obstructions and 22 representing a totally obstructed crossing (Appendix B).

### ***Calculated Texas Priority Index and Investigative Index***

Next, all necessary information needed for calculating the Texas Priority Index and Investigative Index was compiled (vehicle volumes, train volumes, train speeds, five-year accident history, and protection type). A priority index number was calculated for each of the 332 rail-highway intersections using both equations (Appendix B).

### ***Revised Texas Priority Indices***

Two sight distance variables were calculated for each rail-highway intersection (one for the Method 1 revised Texas Priority Index and one for the Method 2 revised Texas Priority Index) based on the intersection's available sight distance. To ensure that a widespread distribution of values was obtained, a frequency analysis was performed on the sight distance variables for each method.

An analysis of the sight distance variables' frequency distributions show that both Methods 1 and 2 produced a wide range of sight distance variables (Figure 4). The sight distance data from the 332 crossings produced 19 of the 23 possible Method 1 sight distance variables and 15 of the 18 possible Method 2 sight distance variables. Although the distributions are similar, Method 1 resulted in a wider distribution of crossings among each of the variables.

It should be noted that approximately 73 percent of the crossings with a sight distance variable of 1.0 (both Methods 1 and 2) are active crossings where track and/or quadrant sight distance is not applicable. A frequency distribution of passive crossings only would result in a more uniform distribution of the sight distance variables. It was therefore determined from the sight distance variable analysis that a good distribution of variables was being obtained, and the variables were applied to the two revised Texas Priority Indices.

### ***Effect of Sight Distance on Texas Priority Index***

To analyze the effect of a sight distance variable on the Texas Priority Index, the initial purpose for the incorporation of the sight distance variable was considered. The need for an additional factor arose in an attempt to better distinguish between the crossings located in the middle of the rank with identical or nearly identical priority index numbers. This differentiation would help engineers determine which crossings were most in need of improvement. Because sight distance is an important design characteristic and is crucial for the driver to make decisions about a crossing, it was considered an important variable for ranking rail-highway intersections in terms

of potential hazard. Thus, the following three measures were taken after the incorporation of a sight distance variable to determine the effectiveness of the sight distance variable:

1. Assess the change in the overall rank of the crossings;
2. Evaluate the redistribution of the passive crossings; and
3. Examine the overall redistribution of the individual index numbers.

*Assess the Change in the Overall Rank of the Crossings.* In order to determine whether the ranks produced by the revised Texas Priority Indices and/or the Investigative Index were significantly different than the current Texas Priority Index, correlation analysis was performed on the ranks. Two tests for correlation were used: Spearman's Rank Correlation and Kendall's correlation (15) (Table 15).

**Table 15. Results of Rank Order Correlation Analysis**

Test for Correlation	Revised Texas Priority Index (Method 1)	Revised Texas Priority Index (Method 2)	Investigative Index
Spearman's Rank Correlation Coefficient	0.97304	0.98981	0.53929
Kendall's-Tau	0.86529	0.91905	0.38725

The values presented in the table are the correlation of each of the indices with the current Texas Priority Index. The two tests for correlation show the same general results. The Spearman rank correlation coefficients show positive agreement between the Texas Priority Index and all three indices. The Investigative Index, however, has a lower correlation coefficient and, thus, a somewhat different rank than the current and revised Texas Priority Indices. Although the two revised indices' ranks are highly correlated with the current Texas Priority Index, Method 1 produces a slightly more different rank than does Method 2.

Considering Kendall's tau, if a pair of priority index numbers was chosen at random from the Method 1 revised index, Method 2 revised index, or the Investigative Index, the probability that the two numbers would show the same relative order in both ranks is 0.87, 0.92, or 0.39, respectively, more than the probability that they would show different order. Again, the revised Texas Priority Indices are highly correlated with the current index, and Method 1 produces a slightly different rank than does Method 2. The probability of choosing a pair of crossings at random from the Investigative Index with different order is greater than the probability than choosing a pair with the same order. Therefore, unlike Spearman's correlation coefficient, Kendall's tau indicates a much more different rank between the current Texas Priority Index and the Investigative Index.

*Evaluate the Redistribution of the Passive Crossings.* Although the correlation tests show that the revised indices are highly correlated with the current priority index, and therefore, no drastic redistribution is taking place due to the sight distance variable, a check was done to ensure that the slight redistribution could be explained.



An analysis of the distributions of the crossings by protection type for each of the priority indices were evaluated (Table 16). The numbers shown are the number of crossings with the respective protection type in each 20 percent of the rank. It can be seen from the distribution of crossings by protection type that the current and revised Texas Priority Indices produce similar results, thus the positive correlation. The Investigative Index, on the other hand, distributes the crossings by protection type somewhat differently.

The current, Method 2 revised, and Method 1 revised Texas Priority Indices place 45, 48, and 51 percent, respectively, of the passive crossings in the top half of the rank. The Investigative Index places 59 percent of the passive crossings in the top half of the rank. Considering flashing lights, the Texas indices place 67, 60, and 61 percent, respectively, in the top half of the rank; the Investigative Index places only 38 percent in the top half of the rank. Finally, the Texas indices place 53, 44, and 37 percent, respectively, of the crossings with flashing lights and gates in the top half of the rank while the Investigative Index places only 24 percent in the top half.

The redistribution of the crossings with flashing lights by the Investigative Index is due in part to the protection type factor for these crossings (0.7 in Texas Priority Index and 0.02 in Investigative Index), thus, the Investigative Index will always rank crossings with flashing lights lower in rank than will the Texas Priority Index. The redistribution of the crossings with flashing lights and gates, however, is due mostly to the sight distance variable in the Investigative Index. The major difference between the Texas Priority Index and the Investigative Index is the accident factor. Texas does not consider the first accident at a crossing while the Investigative Index does. Twenty of the 27 passive crossings which had one or more accidents in the five years were ranked in the top 10 percent of the Investigative Index.

**Table 16. Distribution of Crossings by Type of Protection**

Percent of Rank	Passive				Flashing Lights				Flashing Lights and Gates			
	1 <sup>a</sup>	2 <sup>b</sup>	3 <sup>c</sup>	4 <sup>d</sup>	1	2	3	4	1	2	3	4
20	42	45	46	43	15	13	13	12	9	8	7	11
40	39	42	44	61	17	18	17	4	11	7	6	2
60	45	43	43	56	7	7	7	9	15	17	17	2
80	43	41	41	43	11	11	11	11	12	14	14	12
100	54	52	49	20	2	3	4	16	10	11	13	30
Total	223				52				57			

<sup>a</sup>Current Texas Priority Index

<sup>b</sup>Revised Texas Priority Index--Method 3

<sup>c</sup>Revised Texas Priority Index--Method 2

<sup>d</sup>Investigative Index

There was a subtle redistribution of the crossings by protection factor after the incorporation of a sight distance variable. Some of the passive crossings moved up in rank order while some of the active crossings moved down in rank order. The revised Texas Priority Indices produce slight changes in the distribution that can be attributed to the inclusion of the sight distance variable; therefore, no unexplainable redistribution of crossings is occurring.

*Examine the Overall Redistribution of the Individual Index Numbers.* A frequency analysis was performed on the individual index numbers produced by the current and revised Texas Priority Indices to determine whether there was a redistribution of the individual index numbers. A wider range of index numbers and less ties between crossings would represent a better distribution of the crossings and, thus, better indicate which crossings were most in need of improvement.

Before the incorporation of a sight distance variable in the current index, there were 162 different priority index numbers ranging from 1146 to 1, and 43 percent of the index numbers had two or more crossings tied. After the incorporation of the Method 2 sight distance variable, there were 178 different priority index numbers ranging from 1490 to 1, and 41 percent of the index numbers had two or more ties. Finally, after the incorporation of the Method 1 sight distance variable, there were 194 different priority index numbers ranging from 1834 to 1, and 36 of the index numbers had ties (Table 17).

**Table 17. Ties in Individual Index Numbers in Current and Revised Texas Priority Indices**

Priority Index	Number of Crossings Tied	Number of Occurrences in Index
Texas Priority Index	0	92
	2	27
	3	22
	4	9
	5	5
	6	2
	9	3
	10	2
Revised Texas Priority Index--Method 2	0	103
	2	33
	3	19
	4	13
	5	5
	6	3
	10	1
Revised Texas Priority Index--Method 1	0	124
	2	36
	3	18
	4	7
	5	5
	6	1
	7	1
8	2	

An analysis of the frequency distribution showed that, not only were there fewer of tied index numbers, but the number of ties per index number was also reduced with the incorporation of a sight distance variable. Further, analysis of the cumulative frequency distribution (Figure 5) of the individual index numbers showed that the Method 2 revised index was more effective than the current index in distributing the individual index numbers; however, the Method 1 revised index was the most effective of the three indices in distributing the individual index numbers.

Thus, the inclusion of a sight distance variable in the Texas Priority Index is redistributing the individual index numbers, creating a wider range of index numbers, and eliminating many of the

tied crossings. As a result of this analysis, it was concluded that the sight distance variable had the desired effect on the current Texas Priority Index.

### ***Effectiveness of Priority Indices***

The next step in the field data analysis was to predict which, if any, of the four priority indices examined in this research was the most effective in locating potentially hazardous rail-highway intersections based on exposure, accidents, sight distance, and protection type. To evaluate and predict the effectiveness of the indices, five steps were taken:

1. Evaluate the distribution of the sight distance coding factors;
2. Examine the 40 worst sight distance crossings;
3. Examine the middle third of the priority rankings;
4. Check the weight given to the sight distance variable; and
5. Compare the revised Texas Priority Indices to the Investigative Index.

*Evaluate Distribution of the Sight Distance Coding Factors.* To assist in predicting the effectiveness of the indices in locating potentially hazardous locations, the distribution of the sight distance coding factors, 0 through 22, was examined (Tables 48-21). Since exposure, accidents and protection type are the controlling factors in each of the indices, the distribution of each sight distance coding factor group was compared among the four indices to determine where the indices were ranking the crossings with various sight distance obstructions.

Beginning with the excellent sight distance group (sight distance coding factor 0), it would be desirable for the index formula to place a large number of the sight restricted crossings near the bottom of the rank. This placement is desired because crossings with excellent sight distance should not be high on the priority list unless the crossings are placed high on the list due to high volumes or accident experience. Considering the sight distance coding distribution of the current Texas Priority Index, 45 percent of the excellent sight distance crossings are located in the top 40 percent of the rank, while the Method 2 and Method 1 revised indices rank 41 percent and 38 percent, respectively, of the zero coding factors in the top 40 percent. Regarding the Investigative Index, only 28 percent of the zero coding factors are in the top 40 percent of the rank, and nearly half fall in the bottom 20 percent of the rank.

The same analysis of the poor sight distance group (sight distance coding factors 13 through 15) should result in the opposite of the excellent sight distance group. It could be desirable for the index formulas to place the crossings with poor sight distance near the top of the rank so they are high on the list for improvement unless they are very low volume crossings. Considering the current Texas Priority Index, the majority of poor sight distance crossings are clustered near the middle of the rank with only 23 percent in the top 40 percent. The Method 2 and Method 1 revised indices, however, rank 54 percent and 70 percent, respectively, of the poor sight distance crossings in the top 40 percent. The Investigative Index ranks all but two of the poor sight distance crossings in the top 40 percent.

Finally, a more effective index should place the crossings with unacceptable sight distance (sight distance coding factors 16 through 22) at the top of the rank unless they have very low exposure values. The current Texas Priority Index, however, only ranks one of the four unacceptable crossings in the top 40 percent of the rank. The Method 2 revised index and Method 1 revised index rank two of the four in the top 40 percent of the rank, and the Investigative Index places all four crossings with unacceptable sight distance in the top 40 percent of the rank.

Consequently, because 93 percent of the passive crossings have some type of sight distance obstruction, the distribution of sight distance coding factors for an effective priority index should have specific characteristics. Reading from the lower-left corner of the table, the majority of the sight restricted crossings should be located in a band toward the upper right corner of the table. This band depicts where, a large number of the crossings should fall in the rank when considering sight distance as an additional factor for prioritizing rail-highway intersections. The number of crossings above and below the band should decrease or stay approximately the same as the distance from the band increases. An exception, of course, would be for crossings that are placed high on the priority list due to high volumes. In the case of high-volume crossings, exposure and possibly accident experience should control the placement of the crossings in the rank, and therefore, the number of crossings in the top 10 to 20 percent may be somewhat higher in the excellent, good, and/or above average sight distance categories. The same condition holds for crossings with-below average, poor, and/or unacceptable sight distance; these crossings may be located below the band due to extremely low volumes. A table with these characteristics would represent a good distribution of the sight distance coding factors and, thus, a good distribution of the sight obstructed crossings (Table 22).

From this analysis, it was determined that the Investigative Index as the most effective at ranking the sight restricted crossings, followed by the Method 1 revised index, Method 2 revised index, and the current index, respectively.

***Check the Weight Given to the Sight Distance Variable.*** Because at this point, the Method 1 revised index appeared to be the most effective index, the Method 1 revised index was examined to see how much the 40 worst sight distance crossings were rising in rank to ensure that too much weight was not given to the sight distance variable (Table 24).

After the incorporation of a sight distance variable, the crossings with high exposure (high on the current priority list), toward the top of the rank, did not necessarily "jump" ahead of a large number of crossings; however, they did jump ahead of a few crossings with considerably higher exposure values. The reason for this result is because the index numbers towards the top of the priority list were more spread out, and the multiplicative sight distance variables had a large effect on the high volume crossings due to their high exposure values.

After the incorporation of a sight distance variable, the crossings toward the middle of the priority list, on the other hand, jumped ahead of a larger number of crossings; however, the overall jump did not occur over as large of exposure values (current priority index) as did the jump in high volume crossings. The reason for this result is because the index numbers in the middle of the rank were closer together, and the sight distance variables did not have as large an effect on medium volume crossings.

Finally, after the incorporation of a sight distance variable, the crossings toward the bottom of the priority list did not jump ahead of as many crossings as did the mid-volume crossings, nor did they jump ahead of crossings with much higher exposure values. The reasons for this result are because many of the low volume crossings have the same index number, and the sight distance variable's effect on the index numbers was small.

Therefore, the Method 1 sight distance variable had a large effect on crossings with restricted sight distance, and the Method 2 sight distance variable had the same effect on the rank but to a lesser degree.

*Compare the Revised Texas Priority Indices to the Investigative Index.* Finally, examining the difference between the Method 1 index (more effective than Method 2) and the Investigative Index, the Investigative Index produced a very different rank of the 40 worst sight distance crossings. For example, 13 of the top ranked 14 crossings (high volume) with the current Texas Priority Index, Method 1 revised index, and Method 2 revised indices, were placed an average of 38 ranks lower with the Investigative Index while mid- to low volume crossings were placed higher in rank order. Further, 13 of the 14 crossing placed at the bottom of the rank (very low volume) with the current and revised indices were placed an average of 88 ranks higher with the Investigative Index. The reason for the difference between the revised indices and the Investigative Index (or redistribution of the 40 worst sight distance crossings) is due to the effect of an additive sight distance variables as opposed to a multiplicative sight distance variable. The sight distance variable had a pronounced effect on low volume crossings and only a slight effect on very high volume crossings; this result is not desirable due to the importance of exposure in predicting crossing hazards.

In conclusion, the Method 1 revised Texas priority Index was chosen as the most effective priority index for ranking crossings in terms of exposure, accidents, sight distance, and protection type. The sight distance coding factor distribution table had 40 percent, 47 percent, 40 percent, 37 percent, 39 percent, 85 percent, and 35 percent of the crossings with excellent, good, above average, average, below average, poor, and unacceptable sight distance, respectively in the "band." Further, the Method 1 revised index was effective in redistributing the middle third of the rank by shifting the moderate exposure sight restricted crossings up in rank order. Finally, the Method 1 revised index was most effective at producing a wide range of index numbers with fewer ties between crossings.

The Investigative Index was determined to be more effective in ranking the sight obstructed crossings than the Method 2 revised Texas Priority Index because it placed the crossings with, sight distance, restrictions higher in the overall rank. The Method 2 revised Index, however, was determined to be more effective at ranking the crossings because it placed the crossings in order of decreasing exposure but still gave crossings with sight distance restrictions more priority and produced a more desired distribution of the priority index numbers.

## **CHAPTER V**

### **CONCLUSIONS AND RECOMMENDATIONS**

This final chapter contains the major conclusions and recommendations of this research, which was conducted to evaluate sight distance as a criterion for ranking rail-highway intersections for

improvement in Texas. The current model used by the Texas Department of Transportation has been effective in locating hazardous rail-highway intersections in terms of high exposure; however, it is not as effective in locating potentially hazardous intersections with moderate exposure. The conclusions of the thesis, as stated below, support the use of a sight distance variable to help TxDOT engineers identify those crossings most in need of improvement.

## **Conclusions**

Accident and sight distance data were compiled and analyzed to evaluate sight distance as a criterion for incorporation into the current Texas Priority Index. The following points summarize the conclusions of this research:

1. Sight distance can be used effectively in the Texas Priority Index for ranking rail-highway intersections for improvement. A sight distance variable can help better distribute and distinguish between the crossings in the middle of the rank with moderate exposure values by increasing the range of possible priority index numbers. Further, a sight distance variable can help locate moderate exposure crossings that may be more in need of improvement.
2. Of the four priority indices studied in this research, the Method 1 revised Texas Priority Index was determined to be the most effective in identifying potentially hazardous locations. The Method 1 revised index produced a wide range of sight distance variables which redistributed the sight obstructed crossings by moving them up in the rank. Further examination of the revised rank showed that although the sight distance variables were moving the sight obstructed crossings up anywhere from 4 percent to 24 percent in rank order (depending on degree of obstruction), the index was not moving them ahead of high exposure crossings. Therefore, the sight distance variable was not given too much weight.
3. Although the Investigative Index was determined to be effective in distributing the sight obstructed crossings, it was concluded that the Method 2 revised Texas Priority Index was more effective at considering both exposure of a crossing and the degree of sight obstruction. The Investigative Index placed too many of the high exposure crossings in the middle of the rank by giving too much weight to accidents and sight distance.
4. The majority of passive rail-highway intersections have at least one sight obstruction, and these sight obstructions can be linked to nearly half of the train involved accidents in the past five years.
5. Seventy-nine percent of non-train accidents occurred at active crossings, and non-train accidents were far less severe than train involved accidents. The installation of active warning devices at passive crossings with restricted sight distance will discount the need for track and/or quadrant sight distance, increase the number of non-train accidents while decreasing the number of train involved accidents, and thus, reduce the number of serious injuries and fatalities as a result of rail-highway intersection accidents.

---

**Michigan DOT. *Guidelines for Highway-Rail Grade Crossings*. Lansing, MI, July 2009.**

---

**Overview/Abstract:**

The stated purpose of this document is to provide road authorities, railroads and any other prospective diagnostic study team participants with an overview of typical practices and devices used at highway-railroad grade crossings throughout the state. The guidelines presented herein are based upon proven and sound safety management principles, and they are intended to serve as a convenient reference to ensure consistent and reasonable crossing safety determinations.

---

**Millegan, Yan, Richards and Han. “Evaluation of Effectiveness of Stop Sign Treatments at Highway-Railroad Grade Crossings.” *Transportation Research Record: Journal of the Transportation Research Record*, No. 2122. TRB, National Research Council, Washington, D.C., 2009, pp. 78-85.**

---

**Overview/Abstract:**

Documents research on the effectiveness of stop signs to increase safety at highway-rail grade crossings, compared to a crossbucks-only treatment. This study developed negative binomial accident prediction models for paved and unpaved highway-rail grade crossings that included the effect of stop sign treatment. Significant variables in the NB models for paved roads included control treatment, percent trucks, AADT, number of tracks, adjacent development type, and interaction terms between control type and AADT, trains per day, percent trucks and max time table (train) speed. Stop signs reduced crash rates overall, and were found to be more effective when train and AADT volumes were lower and when multiple tracks were present.

---

**Ogden, Brent. *Railroad-Highway Grade Crossing Handbook – Revised Second Edition*. U.S. Department of Transportation, Federal Highway Administration, 2007.**

---

**Overview/Abstract:**

The purpose of the *Railroad-Highway Grade Crossing Handbook – Revised Second Edition* is to provide a single reference document on prevalent and best practices as well as adopted standards relative to highway-rail grade crossings. The handbook provides general information on highway-rail crossings; characteristics of the crossing environment and users; and the physical and operational improvements that can be made at highway-rail grade crossings to enhance the safety and operation of both highway and rail traffic over crossing intersections. The guidelines and alternative improvements presented in this handbook are primarily those that have proved effective and are accepted nationwide.

## **Captured Information:**

### **LEGAL CONSIDERATIONS REGARDING HIGHWAY-RAIL GRADE CROSSINGS – TORT LIABILITY AND STANDARDS (P 21)**

It has been suggested that railroads and public agencies could significantly reduce tort liability suits involving traffic control devices by implementing four basic steps:

1. Know the laws relating to traffic control devices.
2. Conduct and maintain an inventory of traffic control devices.
3. Replace devices at the end of their effective lives.
4. Apply approved traffic control devices according to specifications and standards.

The area of tort law changes rapidly with court decisions (“case law”) and the enactment and amendment of statutes. All new construction or reconstruction projects should be designed in accordance with accepted standards and criteria, including MUTCD, the latest edition of *A Policy for Geometric Design of Highways and Streets* (the “Green Book”), AREMA recommended practices, and state standards and design policies. All efforts should be made to adhere to the specified criteria. However, under unusual conditions, it may be necessary to use values different from or less than the values that have been established. These departures and the reasons for them should be carefully documented, and the documentation should be retained in the permanent project file by both the public entity and the railroad.

### **ASSESSMENT OF CROSSING SAFETY AND OPERATION (P 47-62 & 249-252)**

The Federal Highway Administration (FHWA) requires each state to develop and implement a highway safety improvement program (HSIP) that consists of three components: planning, implementation, and evaluation. The planning component consists of:

- A process for collecting and maintaining a record of collision, traffic, and highway data, including, for highway-rail grade crossings, the characteristics of both highway and train traffic.
- A process for analyzing available data to identify highway locations, sections, and elements determined to be hazardous on the basis of collision experience or collision potential.
- A process for conducting engineering studies of hazardous locations, sections, and elements to develop highway safety improvement projects.
- A process for establishing priorities for implementing highway safety improvement projects.

The implementation component consists of a process for programming and implementing safety improvements. The evaluation component consists of a process for determining the effect that safety improvements have in reducing the number and severity of collisions and potential collisions. Two types of information are needed: inventory (U.S. Department of Transportation Grade Crossing Inventory) and collision data (FRA, NTSB, FHWA, state/local police).



A systematic method for identifying crossings that have the most need for safety and/or operational improvements is essential to comply with requirements. Various hazard indices and collision prediction formulae have been developed for ranking highway-rail grade crossings. The most commonly used ones are summarized here and further detailed in the *Railroad-Highway Grade Crossing Handbook - Revised Second Edition 2007* starting on page 54 and Appendix F pg 249-252.

### **HAZARD INDEX (P. 54-55)**

A hazard index ranks crossings in relative terms (the higher the calculated index, the more hazardous the crossing), whereas the collision prediction formulae are intended to compute the actual collision occurrence frequency at the crossing.

FAPG requires that the potential danger to large numbers of people at crossings used on a regular basis by passenger trains, school buses, transit buses, pedestrians, bicyclists, or by trains and/or motor vehicles carrying hazardous materials be one of the considerations in establishing a priority schedule. Some states incorporate these considerations into a hazard index, thus providing an objective means of assessing the potential danger to large numbers of people.

### **CLOSURE (PP. 78-82)**

The *Traffic Control Devices Handbook* suggests criteria that may be used for crossing closure.

Criteria for crossings on branch lines include:

- Less than 2,000 average daily traffic (ADT).
- More than two trains per day.
- Alternate crossing within 0.25 mile that has less than 5,000 ADT if two lanes or less than 15,000 ADT if four lanes.

Criteria for crossings on spur tracks include:

- Less than 2,000 ADT.
- More than 15 trains per day.
- Alternate crossing within 0.25 mile that has less than 5,000 ADT if two lanes or less than 15,000 ADT if four lanes.

Criteria for crossing on mainline:

- Any mainline section with more than five crossings within a 1-mile segment.

### **FROM TECHNICAL WORKING GROUP GUIDANCE**

Highway-rail grade crossings should be considered for closure and vacated across the railroad right of way whenever one or more of the following apply:

- a. An engineering study determines a nearby crossing otherwise required to be improved or grade separated already has acceptable alternate vehicular access, and pedestrian access can continue at the subject crossing, if existing.
- b. On a life-cycle cost basis, the cost of implementing the recommended improvement would exceed the cost of providing an acceptable alternate access.
- c. If an engineering study determines any of the following apply:
  - i. FRA Class 1, 2, or 3 track with daily train movements:
    - a. AADT less than 500 in urban areas, acceptable alternate access across the rail line exists within .4 km (one-quarter-mile), and the median trip length normally made over the subject crossing would not increase by more than .8 km (one-half-mile).
    - b. AADT less than 50 in rural areas, acceptable alternate access across the rail line exists within .8 km (one-half-mile), and the median trip length normally made over the subject crossing would not increase by more than 2.4 km (1.5 miles).
  - ii. FRA Class 4 or 5 track with active rail traffic:
    - a. AADT less than 1,000 in urban areas, acceptable alternate access across the rail line exists within .4 km (one-quarter-mile), and the median trip length normally made over the subject crossing would not increase by more than 1.2 km (three-quarters-mile).
    - b. AADT less than 100 in rural areas, acceptable alternate access across the rail line exists within 1.61 km (1 mile), and the median trip length normally made over the subject crossing would not increase by more than 4.8 km (3 miles).
  - iii. FRA Class 6 or higher track with active rail traffic, AADT less than 250 in rural areas, an acceptable alternate access across the rail line exists within 2.4 km (1.5 miles), and the median trip length normally made over the subject crossing would not increase by more than 6.4 km (4 miles).
- d. An engineering study determines the crossing should be closed to vehicular and pedestrian traffic when railroad operations will occupy or block the crossing for extended periods of time on a routine basis and it is determined that it is not physically or economically feasible to either construct a grade separation or shift the train operation to another location. Such locations would typically include:
  - i. Rail yards.
  - ii. Passing tracks primarily used for holding trains while waiting to meet or be passed by other
  - iii. locations where train crews are routinely required to stop their trains because of cross traffic on intersecting rail lines or to pick up or set out blocks of cars or switch local industries en route.
  - iv. switching leads at the ends of classification yards.
  - v. where trains are required to “double” in or out of yards and terminals.

- vi. in the proximity of stations where long distance passenger trains are required to make extended stops to transfer baggage, pick up, or set out equipment or be serviced en route.
- vii. locations where trains must stop or wait for crew changes.

## **NORTH CAROLINA DOT**

NCDOT has developed an evaluation system, approved by the Federal Highway Administration, to determine which crossings have the most critical need for safety improvements. The following information is considered for each crossing in the state:

- train volume
- train speed
- average daily vehicle traffic
- school-bus frequency and passenger load
- existing warning devices
- the number of main-line tracks and side tracks in use
- the crossing's 10-year accident history.

From this, a numerical index is derived, called the "Investigative Index." The higher the index value, the higher the priority for improvement.

Information on each crossing is updated annually. The 300 or so crossings with the highest indexes are selected as candidates for improvement. Diagnostic teams consisting of engineers examine each crossing under consideration. Based on their recommendations - and available funding as many crossings as possible are selected and assigned priorities for improvements. Annual funding has averaged \$10 million in recent years, with some increase in funding levels provided through the federal Transportation Equity Act. After the selected crossings have been added to the Crossing Hazard Elimination Program, new projects are submitted to the N.C. Board of Transportation for approval as additions to the Transportation Improvement Program. NCDOT engineers inspect each new project location and recommend which type of warning devices should be installed: gates, roadside signals, overhead signals (cantilevers), traffic-signal preemption. In some cases, recommendations are made to close a crossing and consolidate its traffic with another adjacent grade crossing or an existing bridge or underpass. Field inspections of new projects are usually completed within three to four months after locations are included in the state's improvement program.

The NCDOT Rail Division has worked with railroad companies and municipalities to identify crossings for possible consolidation or elimination. Candidates include:

- Crossings within a quarter mile of one another that are part of the same highway or street network.
- Crossings where vehicular traffic can be safely and efficiently redirected to an adjacent crossing.
- Crossings where a high number of crashes or near-misses have occurred.
- Crossings with reduced sight distance because of the angle of the intersection, curve of the track, trees, undergrowth or man-made obstructions.

- Adjacent crossings where one is replaced with a bridge or upgraded with new signaling devices.
- Several adjacent crossings when a new one is being built.
- Complex crossings where it is difficult to provide adequate warning devices or which have severe operating problems - such as multiple tracks, extensive railroad-switching operations, or long periods of blocked crossings.
- Private crossings for which no responsible owner can be identified.
- Private crossings where the owner is unable or unwilling to fund improvements AND alternate access to the other side of the tracks is reasonably available.

NCDOT has developed a list of criteria to determine whether a particular crossing should be improved or closed. Criteria include:

- Accident history.
- Vehicle and train traffic (present and projected).
- Type of roadway (thoroughfare, collector, local access, truck route, school-bus route or designated emergency route).
- Economic impact of closing the crossing.
- Alternative roadway access.
- Type of property being served (residential, commercial or industrial).
- Potential for bridging by overpass or underpass.
- Need for enhanced warning devices (four-quadrant gates or median barriers).
- Feasibility for roadway improvements.
- Crossing condition (geometry, sight distance, crossing surface).
- Available federal, state and/or local funding.

**COSTS & EFFECTIVENESS BY WARNING DEVICE (HRGC HANDBOOK) (P 156)**

**Table 44. Countermeasure Type, Effectiveness, and Cost**

<b>Countermeasure</b>	<b>Effectiveness</b>	<b>Cost</b>
STOP signs at passive crossings	Unknown	\$1,200 to \$2,000
Intersection lighting	52-percent reduction in nighttime collisions over no lighting	Unknown
Flashing lights	64-percent reduction in collisions over crossbucks alone	\$20,000 to \$30,000 in 1988
	84-percent reduction in injuries over crossbucks	
	83-percent reduction in deaths over crossbucks	
Lights and gates (two) with flashing lights	88-percent reduction in collisions over crossbucks alone	\$150,000
	93-percent reduction in injuries over crossbucks	
	100-percent reduction in deaths over crossbucks	
	44-percent reduction in collisions over flashing lights alone	
Median barriers	80-percent reduction in violations over two-gate system	\$10,000
Long arm gates (three-quarters of roadway covered)	67 to 84-percent reduction in violations over two-gate system	Unknown
Four-quadrant gate system	82-percent reduction in violations over two-gate system	\$125,000 from standard gates \$250,000 from passive crossing
Four-quadrant gate system with median barriers	92-percent reduction in violations over two-gate system	\$135,000
Crossing closure	100-percent reduction in violations, collisions, injuries, deaths	\$15,000
Photo/video enforcement	34 to 94-percent reduction in violations	\$40,000 to \$70,000 per installation
In-vehicle crossing safety advisory warning systems	Unknown	\$5,000 to \$10,000 per crossing plus \$50 to \$250 for a receiver

## **GRADEDEC 2000**

The Federal Railroad Administration (FRA) developed *GradeDec 2000* as an investment decision support tool for use by state and local authorities. The careful analysis and selection of highway-rail grade crossing investments serves to increase public returns for each dollar invested. It allows state and local decision makers to prioritize highway-rail grade crossing investments based upon an array of benefit-cost measures. *GradeDec 2000* evaluates the benefit cost of grade crossing improvements while explicitly reporting the results for each grade crossing and each benefits category (safety, time savings, vehicle operating costs, reduced emissions, network and local benefits). *GradeDec 2000's* analysis of grade crossing improvements is both at the individual grade crossing and at the corridor or regional level and employs current USDOT benefit-cost methodologies. Both the corridor and the regional analysis modules of *GradeDec 2000* include the USDOT Accident Prediction and Severity Model. The corridor analysis module includes as well the grade crossing risk mitigation model for high speed rail that was developed by the Volpe National Transportation Systems Center.

---

**Park and Saccomanno. "Evaluating Factors Affecting Safety at Highway-Rail Grade Crossings." *Transportation Research Record: Journal of the Transportation Research Record*, No. 1918. TRB, National Research Council, Washington, D.C., 2005, pp. 1-9.**

---

### **Overview/Abstract:**

Presents a sequential modeling approach based on data mining and statistical methods to estimate the main and interactive effects of introducing countermeasures at grade crossings. This research developed crash prediction models both with and without classifiers, and judged the model with classifiers to be a better predictor. Significant variables in the model were highway class, track angle, posted road speed, track type and surface width. However, because classifiers in the model varied based on conditions, this model would likely prove too difficult to statistically develop and use for TxDOT (which is accustomed to using a straightforward crash index).

---

**Prassas, McShane, Lieberman and Engelbrecht. "Warranting Traffic Signals on the Basis of Proximity of Railroad Grade Crossings." *Transportation Research Record: Journal of the Transportation Research Record*, No. 2030. TRB, National Research Council, Washington, D.C., 2007, pp. 59-68.**

---

### **Overview/Abstract:**

Included here because it includes discussion on warranting related to grade crossings. The decision was made that the fatality rate at a highway rail grade crossing near a highway-highway intersection should not exceed the fatality rate at an unsignalized (highway-highway) intersection.

**Overview/Abstract:**

Safety levels at highway/rail interfaces continue to be of major concern despite an ever-increasing focus on improved design and appurtenance application practices. Despite the encouraging trend toward improved safety, accident frequencies remain high, many of which result in fatalities. More than half of these accidents occur at public crossings where active warning devices (i.e., gates, lights, bells, etc.) are in place and functioning properly. This phenomenon speaks directly to the need to re-examine both safety evaluation (i.e., accident prediction) methods and design practices at highway-rail crossings.

With respect to previously developed accident prediction methods, the Peabody Dimmick Formula, the New Hampshire Index and the National Cooperative Highway Research Program (NCHRP) Hazard Index all lack descriptive capabilities due to their limited number of explanatory variables. Further each has unique limitations that are detailed in this paper. The U.S. Department of Transportation's (USDOT) Accident Prediction Formula, which is most widely, also has limitations related to the complexity of the three-stage formula and its steady decline in accident prediction model accuracy over time.

This investigation resulted in the development of an alternate highway-rail crossing accident prediction model using negative binomial regression that shows great promise. The benefit to be gained through the application of this alternate model is: (1) a greatly simplified, one-step estimation process, (2) comparable supporting data requirements, and (3) interpretation of both the magnitude and direction of the effect of the factors found to significantly influence highway-rail crossing accident frequencies.

**Captured Information:**

With respect to previously developed accident prediction methods, the Peabody Dimmick Formula, the New Hampshire Index and the National Cooperative Highway Research Program (NCHRP) Hazard Index all lack descriptive capabilities due to their limited number of explanatory variables. Further each has unique limitations that are detailed in this paper. The U.S. Department of Transportation's (USDOT) Accident Prediction Formula, which is most widely, also has limitations related to the complexity of the three-stage formula and its steady decline in accident prediction model accuracy over time.

This investigation resulted in the development of an alternate highway-rail crossing accident prediction model using negative binomial regression that shows great promise. The benefit to be gained through the application of this alternate model is: (1) a greatly simplified, one-step estimation process, (2) comparable supporting data requirements, and (3) interpretation of both the magnitude and direction of the effect of the factors found to significantly influence highway-rail crossing accident frequencies.

A review of the literature revealed four predominant highway-rail crossing accident prediction models:

- (1) Peabody Dimmick Formula,
- (2) New Hampshire Index,
- (3) National Cooperative Highway Research Program (NCHRP) Hazard Index and
- (4) United States Department of Transportation (USDOT) Accident Prediction Formula (FHWA, 1986).\

## **RESULTS**

Utilizing the combined highway-rail crossing accident/inventory database described earlier, accident frequency per crossing per year served as the dependent variable. The various traffic, roadway and crossing characteristics, including the probability of warning device presence (corrected for endogeneity), were investigated for their significance in affecting highway-rail crossing accident frequency. A  $|t\text{-statistic}| > 1.96$  was taken to be significant corresponding to a 95 percent confidence level.

The Poisson model form was first investigated. As reported in the model output, the overdispersion parameter,  $\alpha=2.30$ , was significant with a t-statistic equal to 6.58 confirming the presence of overdispersion in the data and implying the appropriateness of the negative binomial model form. Model results are provided in Table 3 and are discussed in detail below. The resulting log-likelihood function and restricted log-likelihood function are presented to provide a measure of overall model fit (see Greene, 1993).

## **TRAFFIC CHARACTERISTICS**

Five different traffic characteristics proved to be significant in affecting highway-rail crossing accident frequency. Higher numbers of nightly (not total) through trains and the average annual daily traffic (AADT) in both directions were both found to increase highway-rail crossing accident frequency. This is directly intuitive as higher train and traffic volumes lead to higher potentials for conflict at crossing points.

Also, the greater the number of main track lines and traffic lanes at the crossing, the higher resulting accident frequency. This finding is most likely related to the previous; higher train and traffic volumes require a greater number of tracks and traffic lanes to operate. Though intuitively correlated to the previous findings, high t-statistics and low standard errors for these variables do not suggest the presence of multicollinearity.

Lastly, the higher the defined maximum timetable train speed, the higher the predicted accident frequency. Trains require extensive stopping distances; at higher speeds, these stopping distances extend. Trains traveling at lower speeds may be able to see an obstruction ahead and slow sufficiently to prevent an accident whereas trains traveling at higher speeds may not.

## **ROADWAY CHARACTERISTICS**

Only one roadway characteristic variable proved significant in predicting accident frequency. If a highway is paved, there is a higher likelihood of an accident than if it is gravel. Again, this may be a reflection of earlier findings; paved roads most often exist in higher density areas that experience higher train and traffic volumes. Hence, the accident exposure is increased. Though



intuitively related again, high t-statistics and low standard errors do not suggest inappropriate correlation among these independent variables.

Surprisingly, development type, roadway geometry (i.e., vicinity intersections, approach angles, etc.) and sight obstructions were not found to be significant factors in affecting highway-rail crossing accident frequency. This finding is however, consistent when examining the original data in summary pertaining to this topic. With respect to driver visibility, it was hypothesized that a high number of accidents resulted because the motorist's view of the approaching train was obstructed. Disproving this hypothesis, only 10 percent of the crossings had some form of obstacle in the way of the train and/or tracks at the time of the accident (see Figure 2). (Note that these descriptive statistics represent only highway-rail crossing accidents in California, Montana, Texas, Illinois, Georgia and New York for the years 1997 and 1998 and hence, may not reflect national trends.)

This finding speaks to the design-related issues of this investigation. Design improvement recommendations cannot be made given the above findings since no design-related factors were found to either positively or negatively affect accident frequency at highway-rail crossings.

## **CROSSING CHARACTERISTICS**

Rather than focus on design-related improvements, one may want to consider improvements in the use of warning devices at highway-rail crossings. The probable presence of gates and highway traffic signals were found to significantly reduce highway-rail crossing accident frequency. However, the probable presence of stop signs, flashing lights or bells all was found to increase the predicted accident frequency.

Gates provide a physical blockage that serves as a deterrent to crossing. Highway traffic signals are most commonly present in higher density, higher traffic areas that may physically prevent illegal movement and carry penalties for violation of the signal indication. The commonality of stop signs and the subsequent desensitization of motorists to the sign requirements may explain the unwanted effect of stop signs at highway-rail crossings. Similar reasoning supports the finding that stop lines at a highway-rail crossing resulted in higher accident frequencies. The likelihood for higher accident frequencies resulting from the presence of active warning devices such as flashing lights and/or bells is not easily explained.

In looking again at the original data in summary, highway-rail crossings where the highest level of warning device was either a gate or flashing lights experienced 39 and 22 percent of the total accidents, respectively (see Figure 3). One would suspect that the presence of either gates or flashing lights would predictably result in fewer accidents, unless placed in response to high accident frequencies attributable to other causes. Correcting for endogeneity in the model estimation process did in fact result in a positive effect for the presence of gates but did not for the presence of flashing lights. Several explanations may exist. Flashing lights, due to their active nature, may actually encourage motorists to cross before the train arrives (i.e., beating the train). Also because of their active nature, flashing light may on occasion malfunction. Should a motorist note a singular or frequent malfunction, they may be more likely to disregard the warning.

Two different crossing surfaces, sectional and full wood plank, were also found to increase the frequency of accidents at highway-rail crossings. One would suspect that these surface types are most frequently installed at low-volume highway-rail crossings due to their higher maintenance requirements. Lower volume crossings would predictably lead to lower accident exposure and consequently, lower accident frequencies but this was not the case.

## **ACCIDENT PREDICTION MODEL COMPARISON**

To investigate the plausibility of this negative binomial accident prediction model, Table 4 compares these findings with those of the previously developed accident prediction models. As discussed previously, the Peabody Dimmick Formula, the New Hampshire Index (in its original form) and the NCHRP model are all simple to apply but lack descriptive capabilities. The similarities among these three models is readily apparent in Table 3. Surprising to note is the similarity with respect to the predictive traffic, roadway and crossing characteristics between the USDOT Accident Prediction Formula and the negative binomial accident prediction model developed as part of this investigation.

Both found the number of trains and train speeds to be significant factors in determining highway-rail crossing accident frequencies though slight variations exist (i.e., the USDOT Accident Prediction Formula considers the number of *day* through trains and the *total* number of trains while the number of *nightly* through trains was found to be a significant factor using the negative binomial model form).

Surprisingly, even the type of highway surface – paved or gravel – was found to be a significant factor affecting accident frequency in both the USDOT Accident Prediction Formula and the negative binomial accident prediction model. Intuitively, this factor seems inconsequential compared to other traffic, roadway or crossing characteristics likely to affect highway-rail crossing safety.

The presence of various warning devices at a crossing were also found to be significant in both models though the effect of various warning devices (i.e., positive or negative) on accident frequency was sometimes in opposition between the two models. For example, the presence of flashing lights at a highway-rail crossing is assumed to reduce accident frequency in the USDOT Accident Prediction Formula whereas it was shown to have the opposite effect in the negative binomial accident prediction model. Further, the negative binomial model found crossing surface type to significantly affect the frequency of accidents at highway-rail crossings while the USDOT Accident Prediction Formula does not.

---

**Rail Safety & Standards Board. *Development of a Level Crossing Risk Management Toolkit – Summary Report. June 30, 2008. Online. Available:***  
[http://www.rssb.co.uk/SiteCollectionDocuments/pdf/reports/research/T335\\_rpt\\_final.pdf](http://www.rssb.co.uk/SiteCollectionDocuments/pdf/reports/research/T335_rpt_final.pdf).

---

### **Overview/Abstract:**

Human Engineering Limited was commissioned by the Rail Safety and Standards Board (RSSB) in September 2005 to undertake a comprehensive study into improving road user and pedestrian behaviour at level crossings (research project T335: Improving Road User and Pedestrian

Behaviours at Level Crossings). The purpose of the study was to help the industry understand and manage the human factors risks associated with level crossings of all types. The project comprised five phases of work:

- Phase 1 assessed and reported on the current knowledge of public behaviour at level crossings.
- Phase 2 was concerned with prioritising human factors issues in terms of levels of risk.
- Phase 3 identified and evaluated new and current mitigation measures to influence public behaviour.
- Phase 4 developed a practical guidance toolkit for duty holders and risk assessors.
- Phase 5 refined the mitigation measures in the toolkit and prioritised them in order of potential effectiveness.

The primary output of the work was the Level Crossing Risk Management Toolkit (LXRMTK) which can be accessed at [www.lxrmtk.com](http://www.lxrmtk.com).

The LXRMTK is a web-based database that promotes a performance-based understanding of road user errors and violations at level crossings, enables the systematic evaluation of human factors issues at level crossings, supplies practical guidance on the selection of appropriate risk mitigation measures at level crossings, provides an audit trail for any decisions made regarding the implementation of risk reduction measures and supports the cost benefit analysis process. Toolkit content was developed in collaboration with Network Rail Level Crossing Risk Control Coordinators (LCRCCs) and level crossing engineers. The web-based version of the Level Crossing Risk Management Toolkit was implemented by Lucid Communications and launched to a limited rail industry audience in January 2007.

This final report summarises the full LXRMTK development process and outlines the ongoing maintenance strategy to ensure that it remains a relevant and useful level crossing risk management tool.

### **Captured Information:**

5.3.5 The All Level Crossings Risk Model (ALCRM) was developed by Arthur D. Little and provides the following main functions:

- Calculation of safety risks associated with level crossings.
- A means of estimating the operational losses (cumulative delay costs) associated with level crossings.
- A process of conducting cost-benefit analysis of the option for reducing risk at level crossings.
- A database record of the risk assessments conducted at level crossings.

- Summary reports of crossings of particular interest produced from the database.
- A separate database record of cost-benefit assessments providing options for change.

5.3.7 The ALCRM contains 13 key risk drivers which the level crossing risk control coordinator must gather data on:

- Frequency of trains.
- Blocking back.
- User misuse.
- Gates left open.
- Sun glare.
- Number of users.
- Crossing approach.
- Proportion of HGVs.
- Infrequency of trains.
- Near a station.
- Second train.
- Sighting times.
- Visibility at crossing.

---

**Raub, Richard. “Examination of Highway-Rail Grade Crossing Collisions Nationally from 1998 to 2007.” *Transportation Research Record: Journal of the Transportation Research Record*, No. 2122. TRB, National Research Council, Washington, D.C., 2009, pp. 63-71.**

---

**Overview/Abstract:**

Not directly applicable to the 6642 research, but this paper provides an overview of national statistics on highway-railroad grade crossing safety and crashes. Texas is noted for having the highest number of crashes, but also for having relatively low crash rates (data were subdivided by warning device type).

---

**S.S. Roop, C.E. Roco, L.E. Olson, and R.A. Zimmer. *An Analysis of Low-Cost Active Warning Devices for Highway-Rail Grade Crossings*. NAS 118 HR 3-76B, March 2005.**

---

**Overview/Abstract:**

This research identifies the component costs for traditional active grade crossing systems and explains what influences these costs. Alternative practices and technologies are discussed from a national and international perspective in order to explain the limitations and possibilities of implementing lower-cost active grade crossing systems in the United States. An array of pertinent assessment criteria for low-cost active grade crossing systems was developed to assess the relative merits of each technology. The criteria were incorporated into a decision-making framework and evaluation tool that helped assess the appropriateness of these systems for further evaluation

## **Captured Information:**

### **IMPACT OF TORT LIABILITY LAW ON GRADE CROSSING WARNING SYSTEMS**

The U.S. system of tort liability has had the effect of keeping grade crossing warning systems and related practices in a sub-optimal, yet predictable, balance. The railroads, who largely bear the brunt of litigation resulting from accidents, are adverse to moving away from systems that are highly reliable, long lived, and recognized by the motoring public. Any inclination to do so would likely be punished in the courts either as an act of omission or, paradoxically, as one of commission. By this we mean that if the system put in place to warn motorists of train movement was somehow better than existing systems (i.e., crossbuck or track circuit based), then when an accident occurs at a location equipped with a traditional active system, plaintiffs would contend that the railroads are liable because they know there are better systems available but have chosen to neglect upgrading certain grade crossings — an act of omission. On the other hand, if railroads (or any entity taking responsibility for risk at crossings) install equipment at a grade crossing that is in any way inferior to current technology — independent of cost — then liability will likely be maintained because the responsible entity knows that the alternative system is not as good as existing systems — an act of commission.

This reality, along with all of the other conditions governing grade crossing safety practices (conditions such as train stopping distance, the human propensity to commit errors in judgment or fail in vigilance, and the prevailing sense in our legal system that the motorist's responsibility to yield to train traffic at crossings can be mitigated by a long list of extenuating circumstance), keeps innovation and improvement at bay. When coupled with the railroads' need to monitor and maintain active grade crossing systems, which understandably drives the desire to keep all but railroad employees off railroad property, we are faced with a calcified and difficult to change equation for safety at grade crossings.

The public sector too is adverse to assuming additional risk, cost, and responsibility. The cost of installing active systems, while largely a public expenditure, is but a portion of the total life-cycle cost of keeping active grade crossing warning systems operational. As long as railroads can bear this expensive burden, they will likely continue in their uneasy public safety role. For a public entity to assume responsibility for active systems that are less expensive, but operationally inferior, in any respect, to the existing, accepted practice, is seen as highly unlikely. Tort liability reform is a necessary precursor to change i.e. changing the apportionment of risk (and liability). Work in the area of low-cost active systems will need to address both the reliability of the available options and the kinds of legal changes necessary to allow the introduction of systems designed to offer active traffic control at passive crossings. If it can be demonstrated that overall safety is enhanced by new technology — even if some system failures can be expected e.g., false positives— then the public sector should be encouraged to pursue a higher level of aggregate safety.

## **COST**

The total cost of a traditional active warning system can range from \$100,000 to more than \$200,000 depending on the complexity of the crossing (i.e., the number of tracks, geometry of the crossing, etc.)

### **FRA LOW-COST WARNING DEVICE INDUSTRY ASSESSMENT – JULY 2010**

According to a 1995 U.S. General Accounting Office report, the average cost of installing flashing lights and gates was \$150,000 (1995). If a modest 3 percent inflation rate is assumed, the equivalent cost in current dollars is \$230,000. This is an average value and can vary greatly depending on the complexity of the circuit logic, the type of warning device installed (flashing lights, gates, etc.), and the labor effort required. For example, new active grade crossing systems require a new connection to the electrical power grid, typically at a cost of approximately \$10,000.

---

**Saccomanno and Lai. “A Model for Evaluating Countermeasures at Highway-Rail Grade Crossings.” *Transportation Research Record: Journal of the Transportation Research Record*, No. 1918. TRB, National Research Council, Washington, D.C., 2005, pp. 18-25.**

---

#### **Overview/Abstract:**

This paper introduces a stratified collision prediction model for highway–railway grade crossings. Statistical and analytical procedures employed herein break crossings into clusters and then develop separate crash prediction models for each cluster. As the cluster stratification variables are also the variables used to develop the crash prediction model, this model would be dynamic as new input data for crossings are entered each year, requiring updates to the cluster groupings as well as the application of the cluster-wise crash prediction models. Negative binomial prediction models were used once crossings were grouped by cluster, and the most common explanatory variables in the NB models (in order) were exposure (AADT x daily train volume), sign control, flashing light control, train speed, whistle prohibition, road speed and track angle. Analysis is based on Canadian data, but example applications reveal crash reductions expected from warning device upgrades: sign to flashing lights, 58% crash reduction; sign to gates, 63% crash reduction; flashing lights to gates, 13% crash reduction.

---

**Saccomanno, Frank, Liping Fu, Congming Ren, and Luis Miranda. *Identifying Highway-Railway Grade Crossing Black Spots: Phase 1*. Publication No. TP 14168E. Department of Civil Engineering, University of Waterloo for Transport Canada. Waterloo, Ontario, CN, August 2003. Online. Available: <http://www.tc.gc.ca/eng/innovation/tdc-summary-14100-14168e-1353.htm>.**

---

#### **Overview/Abstract:**

This report presents a risk-based model for identifying highway-railway grade crossing black spots in Canada. This model consists of two prediction components: 1) collision frequency and 2) collision consequence. A graphical approach is adopted to identify crossings with

unacceptable risk (high expected frequencies and/or consequences). These crossings are referred to black spots. The model was applied to Canadian inventory (IRIS) and collision occurrence (RODS) data for the period 1993-2001. Poisson and Negative Binomial (NB) frequency prediction expressions were developed for crossings with three types of warning devices (crossings with signs, flashing lights and/or gates). Both Poisson and NB models were found to provide a good fit to the collision frequency data.

A weighted consequence score was introduced to represent combined collision severity. The weights used in this combined consequence score were obtained from reported insurance claims for fatalities, personal injuries and property damages. A NB expression was developed for the collision consequence model.

The spatial distribution of black spots is discussed with respect to the type of warning device, upgrades in warning device, geographical location, and historical collision occurrence. A list of black spot crossings is provided for the Canadian data based on crossings whose expected number of collisions and/or expected severity score is exceeded at least 0.1% of the time.

## **Captured Information:**

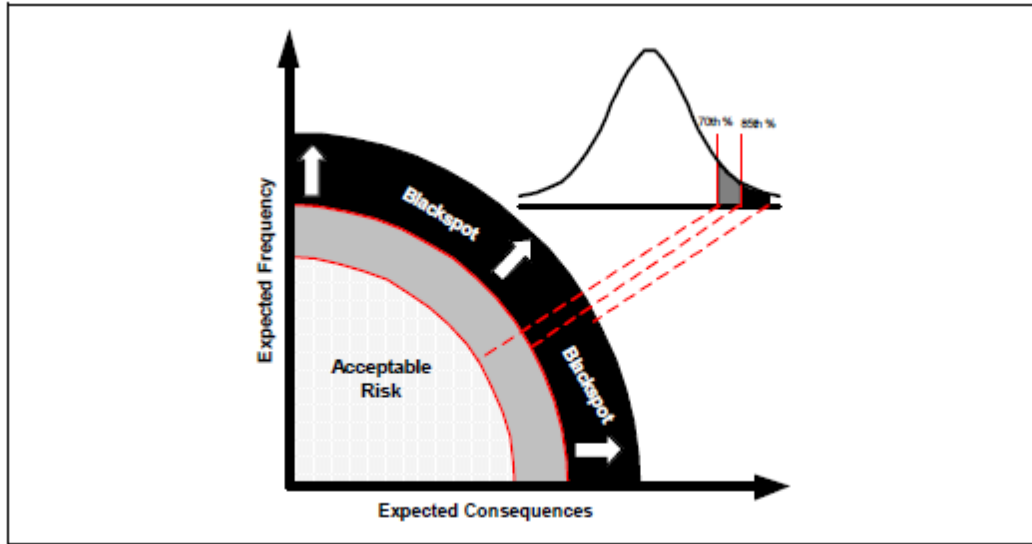
### **1 Introduction**

#### **1.2 Black Spot Identification**

The procedure for black spot identification adopted in this study is illustrated in Figure 1.2. This procedure consists of three related components:

1. Collision prediction
2. Consequence or severity prediction
3. Thresholds for black spot identification and intervention.

A two-dimensional risk prescription for comparing predicted frequencies and consequences to established risk thresholds is illustrated in Figure 1.3. This comparison leads to black spot identification. The y-axis represents the **potential for collisions** at a given crossing (long term likelihood for collisions) over a given period of time. The x-axis represents the **expected number of casualties (fatalities, injuries) and property damage** that result from these collisions. In simple terms, as we move away from the origin along each axis, we move to positions of higher risk. Black spots are defined as crossings with unacceptably high expected risks (frequency and/or consequence). The gray area in Figure 1.3 includes crossings with unacceptable risk but where intervention would not be justified on the basis of intervention cost.



**Figure 1.3 Risk-based black spot identification for a given type of crossing**

A key element in identifying black spots is an objective definition of risk tolerance or threshold that can be linked to various decision options. For example, if risk exceeds a given threshold, a certain type of intervention would be considered. Risk tolerance can be depicted as a threshold line superimposed on the crossing risk estimates (as in Figure 1.3). Any crossing with expected collision frequency and consequence that lies beyond the acceptable risk thresholds would be designated as a black spot. From Figure 1.3, crossings in the dark band would be considered high risk (black spots), such that some form of safety intervention would be justified even at high cost. In practical terms, the upper range of the black spot band in Figure 1.3 is limitless, because there is not an upper bound on unacceptably high risk for the purpose of safety intervention. Crossings in the gray shaded band reflect moderate risks, and intervention is justified if its cost does not exceed its potential safety benefits. Crossings in the un-shaded region of Figure 1.3 would be considered acceptable, requiring no intervention. Such an approach was adopted by the UK Health and Safety Commission (HSC, 1991) in their landmark study on the risks of transporting dangerous substances by road and rail in the UK. In this study, the above prescription requires an in-depth statistical analysis of both expected collision frequency and consequence (severity) to establish objective measures of tolerance. In the absence of an in-depth risk tolerance investigation, we have expressed these thresholds in terms of percentiles (90<sup>th</sup>, 95<sup>th</sup>, 99<sup>th</sup>, etc.) for expected collision frequency and consequence for different classes of grade crossings on the national rail network. These reflect specific crossings where either the expected frequency or consequences is exceeded only 1 percent, 0.5 percent, etc. of the time on the national network (municipal and provincial public crossings).

## **2 Literature Review**

### **2.1 Predicting Collision Frequency at Grade Crossings**

Over the past several decades, a number of collision frequency models have been developed. These models generally have taken one of two basic perspectives: absolute and/or relative risk.



Absolute models yield the “expected number of collisions” at a given crossing for a given period of time. Relative models, on the other hand, yield a “hazard index”, that represents the relative risk (frequency and/or consequence) of one crossing compared to another. Typical absolute collision prediction models were developed by Coleman-Stewart (1976) and the US Department of Transportation (US-DOT; Farr, 1987). The US-DOT model is generally recognized as being the industry standard for collision risk prediction at highway-railway grade crossings. Many relative hazard index models were developed in the United States between 1950 to 1970, including the Mississippi Formula (1970), the New Hampshire Formula (1971), the Ohio Method (1959), the Wisconsin Method (1974), Contra Costa County Method (1969), the Oregon Method (1956), the North Dakota Rating System (1965), the Idaho Formula (1964), the Utah Formula (1971), and the City of Detroit Formula (1971).

## **2.4 Risk Factors Explaining Collisions at Grade Crossings**

Risk factors refer to crossing attributes that explain variation in risk including the expected number of collisions and their consequences. In this analysis we consider the five types of risk-factors: warning device, daily highway traffic volume, highway surface width, number of tracks, number of daily trains, and vehicle and driver characteristics. Exposure at a given crossing is defined as the cross-product between the average daily traffic volume (AADT) and the number of trains per day.

### **2.4.1 Warning Devices**

The type of warning device has a significant effect on risk at grade crossings (Farr, 1987). In general, there are two types of warning devices: passive and active. Passive devices include signs. Active devices include flashing lights and/or gates. In this study, other warning devices have been categorized under these three main classes.

Passive traffic control systems consisting of signs, pavement markings, and grade crossing illumination, identify and direct attention to the location of a grade crossing. Passive devices themselves provide no information to motorists on whether a train is actually approaching. Instead, crossing users must, upon being notified that they are entering a grade crossing, determine for themselves whether a train is approaching and if it is safe to cross the tracks.

Active traffic control systems provide crossing users with the message that a train is actually approaching the crossing. The user must surmise as to where the train could be with respect to the crossing (e.g., 5 secs, 10 secs, 15 secs, etc). When a train is detected, typically some form of track circuitry activates the warning device at the grade crossing, such as: 1) flashing light signals and bells, or 2) automatic gates.

### **2.4.2 Highway Characteristics**

Previous research has highlighted a number of highway characteristics affecting collisions at grade crossings. These include traffic volume on roads, vehicle speed, road surface type and width, number of lanes, etc. This section summarizes the main findings on the effects of highway characteristics on grade crossing collisions.

### ***Traffic volume***

Traffic volume on an intersected highway of a grade crossing has obvious impact on the collision risk. The more traffic volume on highway, the more vehicles are exposed to conflicts with train movements, the greater the probability of collision. Previous collision studies such as Coleman-Stewart (1976) and the USDOT model (Farr, 1987) have used the traffic volume as one of the important variables in their collision prediction models. Traffic volume is expressed in terms of the Average Annual Daily Traffic volume (AADT).

### ***Surface width***

Surface width affects vehicle-train collisions as well as vehicle-vehicle collisions. Width can be used to reflect the number of lanes. An increase in the number of traffic lanes translates into higher traffic volume on the grade crossing and greater chances for collisions. In addition, driver visibility usually decreases as traffic at a grade crossing increases. Crossing surface width refers to the width of the highway in metres plus shoulders (0.5 metres on each side) as measured at the crossing approach. The distance is measured at right angles to the centre line of the highway.

### **2.4.3 Railway Characteristics**

The main railway characteristics that affect risk at grade crossings include number of tracks and number of trains per day.

#### ***Number of tracks***

Tracks are categorized into several classes (single main line, double main line, siding, switching, etc). Mainline tracks usually carry through train movement, while other tracks serve switching movements or terminal movements. The number of tracks affects collision frequency and consequence.

#### ***Track angle***

Track angle refers to an intersection angle between the roadway and track. The convention is to report this angle with respect to a perpendicular line to the track at its intersection with the roadway centre line. Previous research suggests that track angle has a slight effect on collision frequency and consequence.

#### ***Number of trains daily***

Trains are classified into through trains (freight train and passenger train) and switch trains. The train characteristics, such as train length, weight, braking system, speed, and number of daily trains influence the safety at highway-railway grade crossings. In the US DOT model, in addition to considering train exposure as one variable for both collision frequency and consequence, the number of daily through trains was also found to affect collision frequency.

In the US-DOT model, train speed was found to affect both collision frequency and consequence. For consequence, an increase in train speed results in an increase in collision severity.

### **2.4.4 Driver and Vehicle Attributes**

Driver attributes are a key component to explaining the occurrence of highway railway grade crossing collisions. Driver's decision and reaction time, as well as his ability to judge train speed and observe multiple events at once, are all important factors. At passive crossings, driver error

and misperception may lead to collisions. Active crossings can reduce recognition errors, but produce other forms of driving behavior error.

Highway-railway grade crossings are exposed to diverse vehicles, from motorcycles to tractor-trailers. These vehicles have contrasting characteristics that directly influence safety at grade crossings. Equally important is the cargo these vehicles carry, such as children in school buses and dangerous goods in trucks. Vehicle speed, size and weight, accelerating and braking performances are important attributes affecting the risk at grade crossings. On average, heavy trucks are involved in 16 percent of all crossing collisions.

## **4 PREDICTING COLLISION FREQUENCY**

This section describes the development of collision prediction models for highway-railway grade crossings in Canada. Distinctive collision prediction models were developed for each type of warning device: signs only (S), flashing lights (F) and gates (G). Various assumptions on the distribution of observed collisions were investigated. Based on validation analysis using a data set independent of calibration, a Poisson prediction model was found to yield the best results. This model was used to investigate the sensitivity of collisions at crossings to various factors, including crossing type, road speed, AADT, surface width, train speed, number of tracks, number of trains, and warning device.

### **4.4 Sensitivity Analysis (Poisson Collision Prediction Model)**

This section describes a sensitivity analysis to identify those risk factors that have a significant impact on collisions at grade crossings. This analysis can shed some light on possible cost-effective strategies for reducing collisions at these crossings.

#### **4.4.1 Effects of Warning Device**

Figures 4.3(1) and 4.3(2) show the ratios of expected collisions among the three types of warning devices as related to AADT and train speed. Three observations emerge from this analysis: First: the ratios of predicted collisions for flashing lights (Type F) and gates (Type G) as compared to signs (Type S) are consistently lower than 1.0 for all levels of AADT and train speeds. This suggests that if crossings are upgraded from signs to flashing lights or gates, some reduction in the number of collisions could occur. A word of caution is advised here. The results could be affected by lack of crossings with flashing lights and gates in the lower ranges of exposure (AADT). Second: the expected benefit of upgrading from signs to flashing lights appears to be insensitive to train speed, but dependent on AADT. As expected, the higher the AADT, the lower the benefit obtained from the introduction of flashing lights, but the higher the benefit from installing gates. Third: the model suggests that it is always beneficial to upgrade crossings from signs to flashing lights or gates. This finding depends on the range of exposure experienced at crossings for different types of warning devices. Collision reduction resulting from WD upgrading appears to be higher at crossings with higher train speeds.

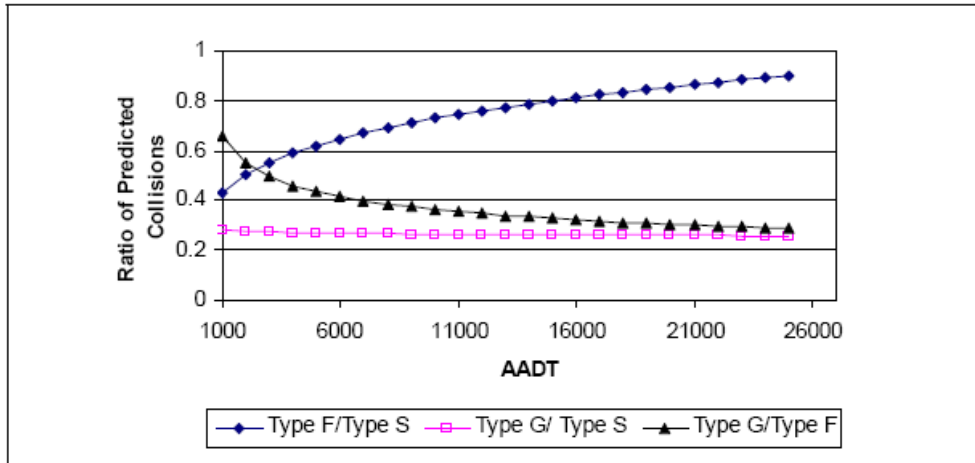


Figure 4.3(1) Relationship between collision ratios and AADT for three types of warning devices (controlled by train speed = 30 mph, road speed = 50 km/h, number of tracks = 2, surface width = 12 ft, and trains daily = 6)

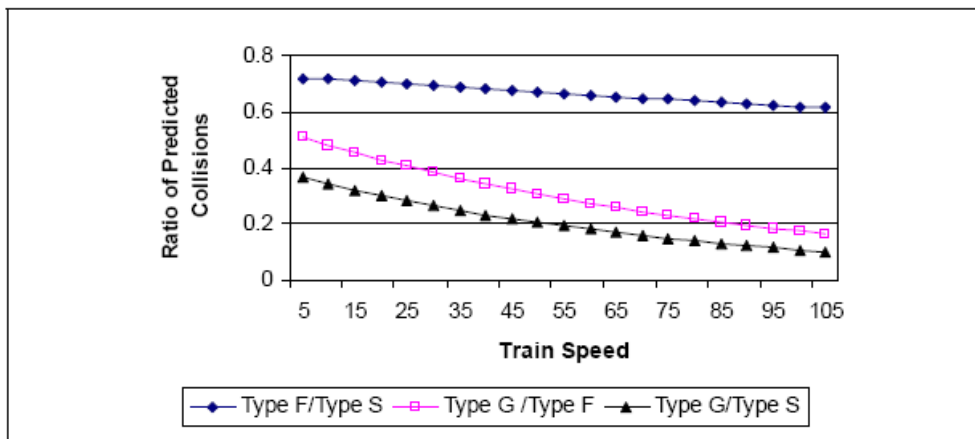


Figure 4.3(2) Relationship between collision ratios and train speed for three types of warning devices (controlled by AADT = 8000 vehicle/day, road speed = 50 km/h, number of tracks = 2, surface width = 12 ft, and number of trains daily = 6)

#### 4.4.2 Effects of Highway Characteristics

The key highway-related risk factors that were found to explain collisions at grade crossings are: highway traffic volume or AADT (included in the variable *exposure*), road speed and surface width. Figures 4.4(1) and 4.4(2) illustrate the relationship between expected collisions per year versus AADT and Road Speed for the three types of warning devices. As expected, traffic volume has a negative effect on the safety of grade crossings, regardless of the type of the warning device. Also, the expected number of collisions at crossings increases as traffic volume increases. The rate of increase depends on the type of warning devices, with sign and flashing light crossings having the highest and the gate crossings having the lowest. This means that traffic volume has a greater effect on collisions at sign and light crossings than those at flashing light and gate crossings. We note that at higher levels of AADT the predicted collisions at flashing lights increases to a value close to that obtained for signs. This implies that at higher levels of AADT the effectiveness of flashing lights diminishes.

Road speed has significant effect on the occurrence of collisions at gate crossings, but a negligible effect at crossings equipped with signs and flashing lights. Increases in road speed at gates result in an increased number of expected collisions. This result differs from that obtained in the US-DOT model, where road speed was not included for all types of warning device.

Other factors such as road “surface width” were found to have a significant effect on collisions at crossings equipped with flashing lights, their overall contribution to predicted collisions was not as large as that obtained for traffic exposure and road speed.

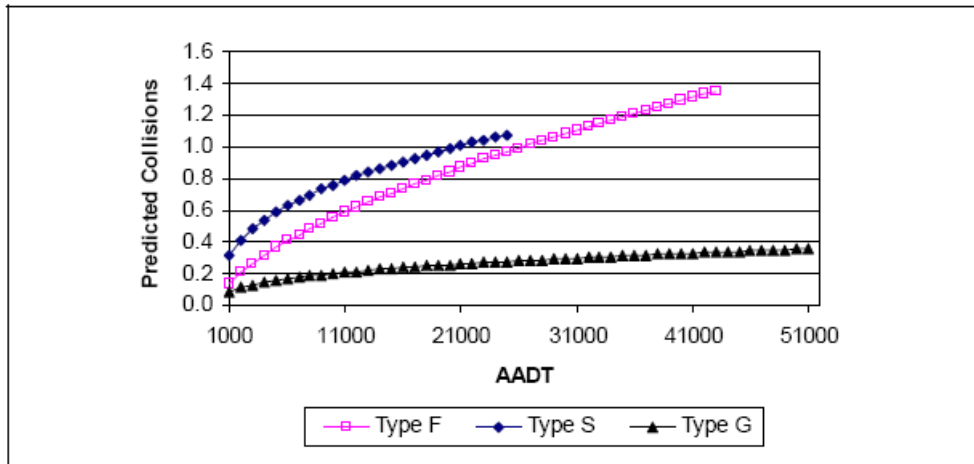


Figure 4.4(1) Relationship between collisions and AADT for three types of warning devices (controlled by train speed = 30 mph, road speed = 50 km/h, number of tracks = 2, surface width = 12 ft, and number of trains daily = 6)

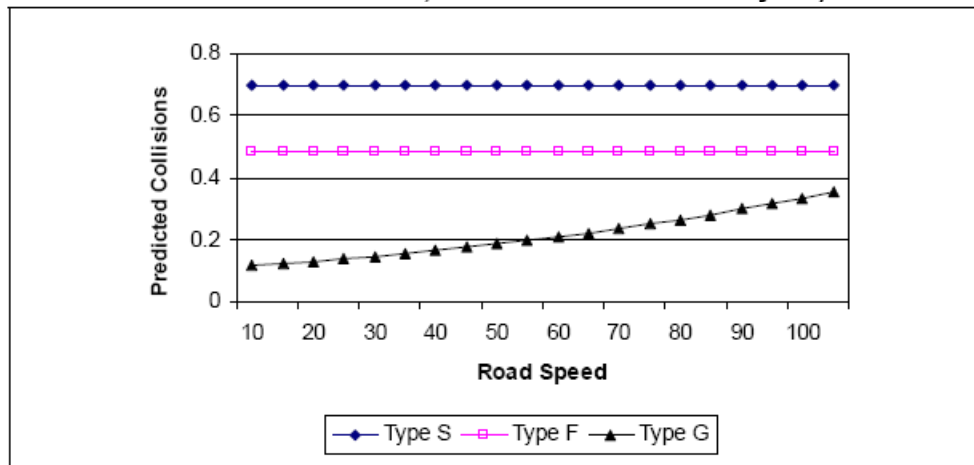


Figure 4.4(2) Relationship between collisions and road speed for three types of warning devices (controlled by AADT = 8000 vehicle/day, train speed = 30 mph, number of tracks = 2, surface width = 12 ft, and number of trains daily = 6)

#### 4.4.3 Effect of Railway Characteristics

The railway-related characteristics that influence the expected number of collisions at crossings are number of trains daily, train speed and number of tracks. Figures 4.5(1) and 4.5(2) illustrate these relationships for the three types of warning devices. The number of tracks has no effect on collisions at crossings with signs and flashing lights, but a positive effect at gates.

Train speed has a positive (adverse) impact on collisions at sign crossings and flashing light crossings. With increases in train speed, collisions at these two types of crossings increase exponentially. At crossings equipped with gates, train speed has no affect on collisions. For the same train speed, sign crossings tend to experience more collisions than the other two types of crossings, and crossings with flashing lights tend to experience more collisions than crossings equipped with gates.

More collisions are expected with increases in the number of trains daily. At lower train volume, sign crossings tend to experience more collisions than at crossings equipped with flashing lights and gates. At higher train traffic levels, the expected collisions at crossings with flashing lights are close to those experienced to those for signs.

At lower values of trains daily, the sign crossings have the most collisions among the three types of crossings, followed by flashing light crossings. At these levels, crossings equipped with gates experience fewer collisions than for the other two types of crossings. At lower levels of “trains daily”, the models suggest that it would be beneficial to upgrade warning devices from signs to flashing lights or gates, but at higher values upgrading from signs to flashing lights would yield reduced safety dividends. At this level, upgrading to gates is recommended.

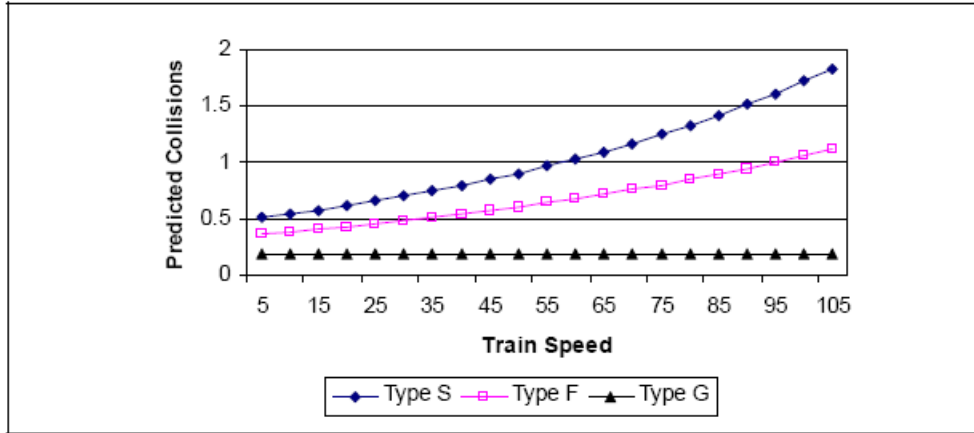


Figure 4.5(1) Relationship between collisions and train speed for three types of warning devices (controlled by AADT = 8000 vehicle/day, road speed = 50 km/h, number of tracks = 2, surface width = 12 ft, and number of train daily = 6)

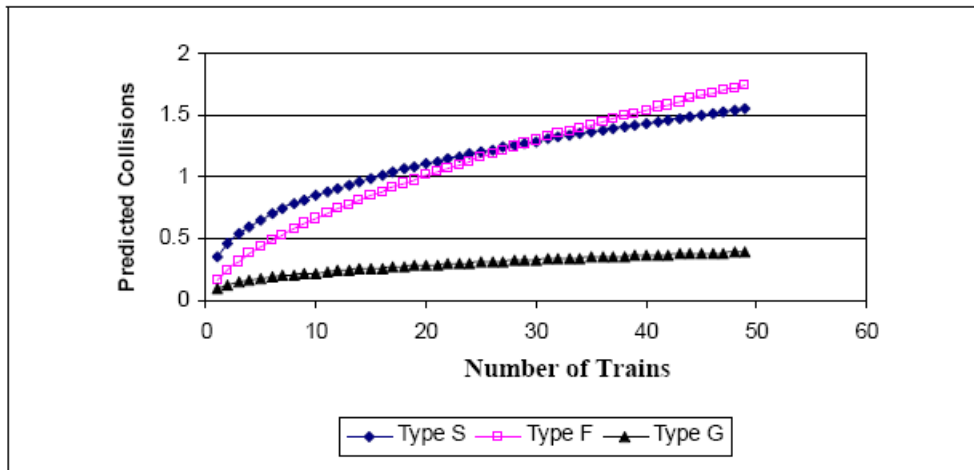


Figure 4.5(2) Relationship between collisions and number of trains for three types of warning devices (controlled by AADT = 8000 vehicle/day, train speed = 30 mph, road speed = 50 km/h, number of tracks = 2, and surface width = 12 ft)

#### 4.4.4 Summary of Collision Prediction Results

A systematic safety improvement program for highway-railway grade crossings relies on models and tools that can be used to identify black spots (BS) where the risk of collision is unacceptably high and safety countermeasures are most warranted. This section presents a set of collision prediction models developed specifically for Canadian occurrence and exposure data. The US-DOT model was evaluated and found not to apply to Canadian data. Separate Poisson and Empirical Bayesian (EB) models were developed and evaluated for three different types of warning devices using crossing data for all the regions in Canada. Chisquare goodness-of-fit tests indicate that the Poisson model is best able to fit the observed data when crossings were grouped according to warning device, road and train volume (traffic exposure) and train speed. A sensitivity analysis using the calibrated models, lead to the following findings:

For the same crossing conditions (AADT, train speed, road speed and number of tracks), crossings equipped with signs experience the highest expected number of collisions per year

among the three types of warning devices. This suggests that reduction in collisions can be expected if the warning devices at signed (passive devices) crossings are upgraded to flashing lights and gates (active devices).

While it is always beneficial to upgrade crossings from signs and flashing lights to gates, the relative effect of upgrading depends on road traffic volume, number of trains, train speed and surface width.

The expected number of collisions at crossings increases as road and train traffic volume increases. Traffic volume has a higher effect on expected collisions crossings with signs and flashing lights than at crossings equipped with gates. Increased train speed has an adverse impact on the expected number of collisions at crossings with signs and flashing lights. For crossings equipped with gates, the effect is negligible.

We note that Canada has reported a noticeable reduction in collisions at grade crossings over the last 20 years. The above model indicates fewer collisions at crossings equipped with gates than crossings equipped with signs or flashing lights. This provides a possible explanation for the trend of collisions decreasing over time. That is, it could be due to an increasing number of crossings being upgraded to flashing lights and gates. However, this assertion needs further investigation, especially within the context of changing reporting thresholds.

## **6 BLACK SPOT IDENTIFICATION AND ANALYSIS**

In this analysis two approaches were considered for identifying grade crossing black spots: 1) a two dimensional graphical approach, and 2) a combined risk index approach. In the graphical approach, frequency and consequences are represented as separate axes in a two-dimensional plot (as illustrated in Figure 1.3). Critical thresholds values were superimposed on this plot to yield crossings with unacceptably high frequencies and/or consequence scores as predicted by the models. These crossings are referred to as black spots.

Alternatively, we have also obtained a combined risk index for each crossing based on the product of expected collision frequency and consequences score (given a collision). This measure can also be compared to pre-set thresholds to determine whether such crossings should be considered for intervention.

The number of black spots targeted for intervention depends on underlying thresholds for predicted frequency, consequence and risk. Obviously as these thresholds are reduced, an increased number of crossings become black spots.

With an increased number of black spots, the cost of intervention is expected to increase. Practicable thresholds can be established by considering the tradeoff between safety intervention and its cost. Without knowing both the safety benefits and cost of the intervention, we cannot obtain practicable thresholds for black spot identification, an exercise that is outside the scope of this report.

This section of the report briefly introduces the graphical and combined risk index approach for black spot identification, and discusses black spots resulting from varying thresholds. The basic features of a sample of black spot crossings from Canadian data are discussed.



## 6.1 Black Spot Identification - Graphical Method

A total of 10,797 highway-railway grade crossing observations were considered for black spot identification in all regions of Canada. For each crossing, collision frequency and consequence/collision were predicted using the above models for different crossing characteristics, AADT and speed. For frequency prediction we used the Poisson model shown in equations 4.2 - 4.4, while for consequence prediction we used the NB model given in equation 5.3.

Frequency and consequences at each crossing were plotted as shown in Figure 6.1. The distribution of crossings by risk/year (expressed as the product of expected frequency and consequence score) is illustrated in Figure 6.2. In Figure 6.1, the horizontal axis represents predicted consequence/year for all collisions at each crossing, while the vertical axis reflects the expected collision frequency/year at these crossings. Three thresholds values were considered: crossings whose predicted collision frequency and/or consequence score is exceeded only 0.1 percent, 0.2 percent, and 0.5 percent of the time.

Figure 6.1 shows that crossings with high frequency differ from crossings with high consequence scores. This indicates that Backspots based solely on one criterion fail to provide an adequate representation of crossings that should be targeted for intervention. Clearly, it should not be using frequency or consequence in isolation to establish black spots, but rather use both criteria to provide a more complete picture of the underlying risks.

Figure 6.2 provides additional insight into black spot identification where a combined risk measure is used. Note that over 97 percent of crossings have expected risks/year the 0.1 percent threshold (frequency times consequence score). A total of 269 crossings have predicted risks greater than 0.1 percent. If a combined risk measure is adopted, it is tempting to designate these crossings as black spots.

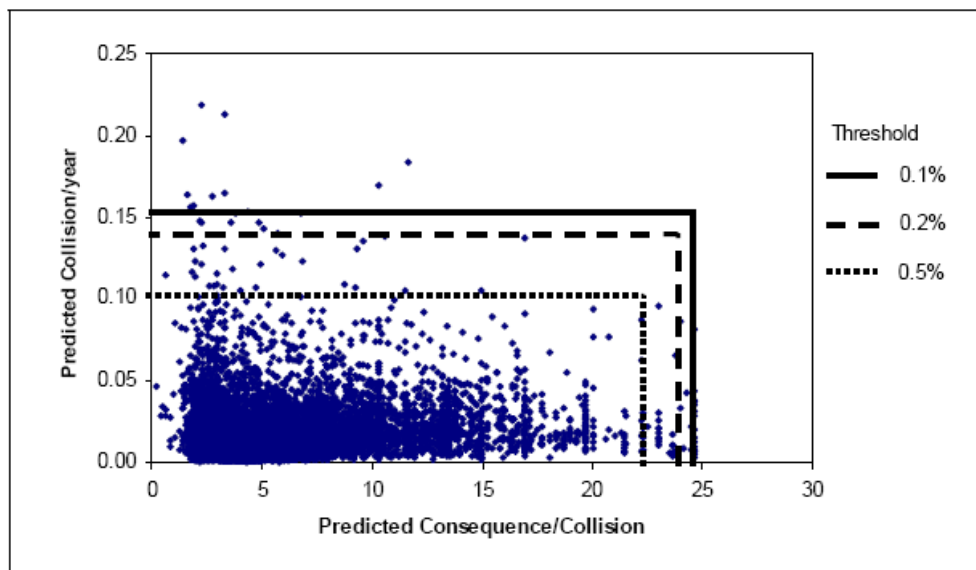
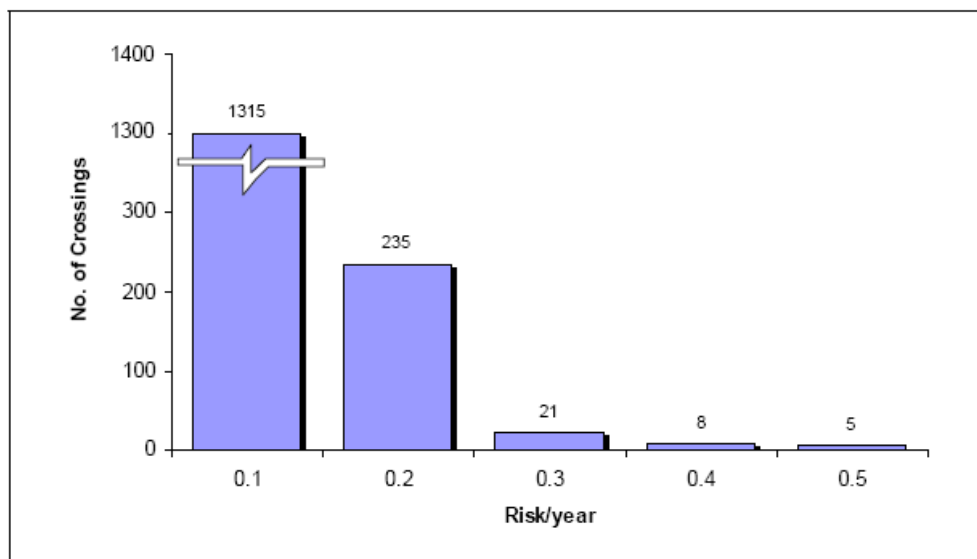


Figure 6.1 Black spot identification (graphical method – frequency and consequence/collision)



**Figure 6.2 Black spot identification (combined risk index)**

In this study we adopted a graphical frequency versus consequence approach for identifying black spots. There are essentially two reasons for this: 1) If frequency and consequences are combined in a single risk index, high frequency/low consequence and high consequence/low frequency crossings could result in a low risk index and be excluded from intervention. 2) Furthermore, high frequency/low consequence, low frequency/high consequence risk could reflect a similar index although different intervention strategies are required. If risk index alone is used, it is more difficult to tailor intervention strategies to specific safety problems at each crossing. Counter-measures tailored to reduce frequency are very likely to differ from counter-measures tailored to reduce the collision consequences.

### 6.3 Average Attributes of Crossing black spots

A total of 100 crossings were selected randomly from the non-black spot sample and compared with the top 100 black spots (crossings with highest consequence scores and frequencies). Table 6-2 summarizes the mean values of selected factors for the top 100 black spot and non-black spot samples. On average, black spot crossings exhibit higher train speeds, more acute (from perpendicular) highway/track angles, higher road speeds, and higher road (AADT) and train volumes.

**Table 6-2 Mean value for black spots and non-black spots**

Mean Value	Black spots	Non-black spots
Train Speed (mph)	65.51	39.3
Road Speed (km/h)	64.20	60.65
Train Daily	32.04	7.58
AADT	10835.38	2717.42
Surface Width (ft)	15.71	11.33
Track Number	1.46	1.27
Track Angle	75.99	71.01

## 7 CONCLUSIONS AND RECOMMENDATIONS

### 7.1 Conclusions

This research presents a risk-based methodology for identifying highway railway grade crossing black spots in Canada. The main conclusions obtained from the research are summarized as follows.

#### **Modelling collision frequency**

1. A number of alternative models were investigated to predict collisions at grade crossings. It was found that Poisson distribution produced similar results when compared to Negative Binomial and Empirical Bayesian methods. Separate collision prediction models for each type of warning device were obtained.

These models yielded better predictions than were obtained for a single expression with warning device included as an independent variable. These findings proved consistent with results obtained by the US-DOT for predicting collisions at grade crossings. From this analysis, we concluded that the expected collision frequency is best modelled using Poisson regression with separate expressions for different types of warning devices. In this case we used three classes of warning device: signs, flashing lights and gates.

2. The statistical analysis concluded that traffic exposure (AADT x number of trains daily) was the most important factor affecting collision frequency for all types of highway-railway grade crossings. The nature of this relationship is nonlinear and is affected by type of warning device. For crossings with passive controls (e.g., signs only), train speed and exposure were found to provide a significant explanation for differences in the expected number of collisions per year. For active crossings equipped with flashing lights, the significant input factors were train speed, road surface width and exposure. For crossings equipped with gates, the input factors for frequency prediction were road speed, number of tracks and exposure. These findings were also reasonably consistent with those obtained in the US-DOT models.

The collision frequency expressions for each type of warning device are summarized as follows, in Figure 7-1:

**Table 7-1 Collision frequency models**

Warning device	Collision frequency models
Signs	$E(m_S) = e^{[-5.66 + 0.0128 * TSPD + 0.3791 * \ln(EXPO)]}$
Flashing lights	$E(m_F) = e^{[-9.1620 + 0.0112 * TSPD + 0.0151 * SW + 0.6103 * \ln(EXPO)]}$
Gates	$E(m_G) = e^{[-7.2304 + 0.0118 * RSPD + 0.1912 * TN + 0.3526 * \ln(EXPO)]}$

Where:  $TSPD$  = Maximum train speed (mph)  
 $EXPO$  = Cross product of AADT and number of trains daily  
 $SW$  = Surface width (ft)  
 $RSPD$  = Road speed (km/h)  
 $TN$  = Number of railway tracks (both directions)

#### **Modeling collision consequence**

3. A consequence score was developed based on average costs associated with different levels of collision severity, including fatality, serious injury and property damage. By using a single consequence score, the full spectrum of consequences associated with each collision was represented and incorporated into the black spot identification process. As in the case for frequency, different prediction models were investigated for collision consequences. It was found that a Negative Binomial model yielded the best fit results for predicting consequence at grade crossings.

4. Unlike the collision frequency model, warning device type was not found to be statistically significant in explaining collision consequence (severity). Train speed, number of tracks, track angle, number of vehicles and involved persons were found to have a significant effect on the expected collision consequences at crossings. The consequence prediction model assumes a prior occurrence of a collision.

The consequence model recommended for the identification of black spots is:

$$E(C_q/C) = e^{(0.3426 * PI - 0.2262 * TN + 0.0069 * TA + 0.0250 * TSPD)} \quad (5.3)$$

Where:  $E(C_q/C)$  = Expected consequence/collision  
 $PI$  = Number of persons involved  
 $TN$  = Number of railway tracks (both directions)  
 $TA$  = Track angle (degrees)  
 $TSPD$  = Maximum train speed (mph)

**Risk analysis and black spot identification**

5. A two-dimensional graphic approach was adopted to compare the predicted risks (frequency and consequence) at individual grade crossings. The risk graph included predicted collision frequency on the Y axis and predicted collision consequence in X axis, with each point representing an individual crossing. By plotting all crossings on this graph, system-wide risk distribution patterns can be conveniently identified for high-risk crossings (black spots).

6. The frequency versus consequence risk graph was used to identify those crossings with unacceptable collision frequency and/or consequence, which should be treated as black spots. Ideally, black spots should be identified based on risk thresholds determined from a comprehensive and objective appreciation of societal preferences and risk tolerance. Potential reductions in risk could be compared to increased costs following the introduction of different countermeasures. Such an analysis, however, is outside the scope of this study. For the purpose of demonstrating the model, however, in this report we ranked the crossings in the RODS/IRIS database with respect to their expected collision frequency and consequence. Crossings with expected frequency or consequence that were exceeded 0.1 percent of the time were designated as black spots. The 0.1 percent threshold was set subjectively. In this exercise a number of different thresholds were considered (0.1 percent to 0.9 percent exceeding) for black spot identification. In practical terms, different percentage thresholds were found to potentially incur different costs or intervention budgets. It would cost more to meet the 0.9 percent threshold than the 0.1 percent threshold, since more black spots would be targeted for intervention.

### **Identifying highway-railway grade crossing black spots in Canada**

7. A list of black spots was identified on the basis of expected collision frequency and consequence at individual crossings across Canada for the assumed 0.1 percent threshold. It was found that the identified black spots were clustered in Saskatchewan (due to high traffic frequency) and Ontario and Quebec (due to high consequence). Most black spots based on collision frequency were located in urban areas with high AADT. Black spots based on collision consequence were generally located in rural areas with high train speeds but not necessarily high AADT.

8. Canada has reported noticeable reductions in collisions at grade crossings over the past 20 years. The risk models developed in this research indicate fewer collisions at crossings equipped with flashing lights and gates than at crossings with signs. This finding provides one possible explanation for the decreasing trend in collisions over time, i.e. an increased number of crossings that have been upgraded from passive to active warning devices (in particular gates).

However, this assertion needs to be investigated further, especially within the context of different collision reporting standards (severity thresholds) and at grade crossing closures.

---

**Saccomanno, Fu and Miranda-Moreno. "Risk-Based Model for Identifying Highway-Rail Grade Crossing Blackspots." *Transportation Research Record: Journal of the Transportation Research Board*, No. 1862. TRB, National Research Council, Washington, D.C., 2004, pp. 127-135.**

---

#### **Overview/Abstract:**

Developed Poisson and negative binomial (NB) crash frequency prediction expressions for crossings with signs, flashing lights and gates; found that NB provided a better fit to crash data. Significant variables in the NB expressions for signs included train speed and exposure; for flashing lights the significant variables were surface width, train speed and exposure; and for crossings with gates the significant variables were number of tracks, road speed and exposure. This research also developed crash consequence severity scoring to account for crash severity when predicting grade crossing crashes and identifying blackspots. Warning device type had a significant impact on crash frequency, but not crash severity. Train speed, number of tracks, track angle, number of vehicles and involved persons had a significant impact on expected crash severity.

---

#### **Synthesis of Germany Literature**

---

#### **Overview/Abstract:**

Several documents from Germany were translated and reviewed.

#### **Captured Information:**

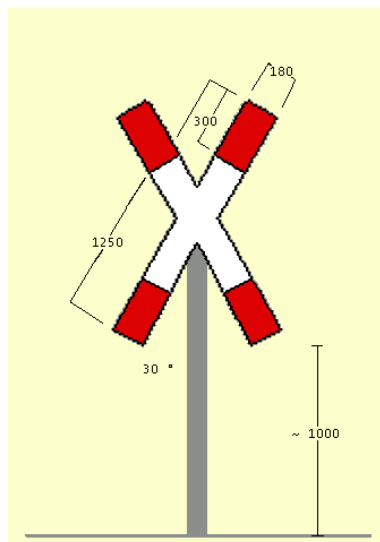
**German Train Crossing Regulations**

**3/16/2011**

**Summary**

## Review of Railroad Crossing Regulations (I)

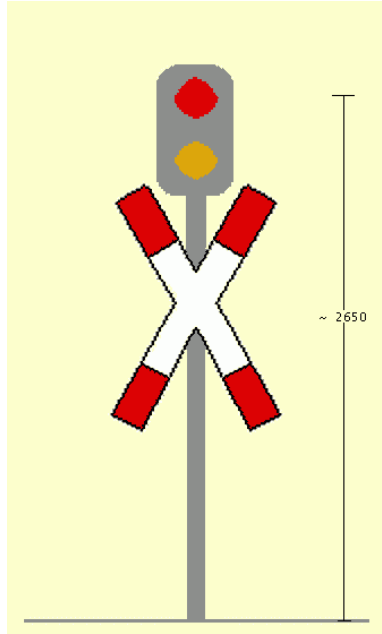
- Definitions
  - Low volume crossing: typically less than 100 vehicles per day
  - Moderate volume crossing: typically 100 to 2,500 vehicles per day
  - High volume crossing: typically more than 2,500 vehicles per day
  - Adequate visibility: A railroad crossing has adequate visibility if the driver of a motor vehicle can view enough of the train route in a distance from the crossing that she can cross the train tracks without danger or stop before them as needed.
  - Private road: Private roads without public traffic and marked as private roads.
- Railroad crossings without grade separations are only allowed on train routes with a speed limit of 160 km/h (99.4 mph).
- At railroad crossings, trains have the right of way, which must be marked by a St. Andrew's cross (Figure 1). However, the St. Andrew's cross is not required for the following crossing types:
  - Field and forest roads if the crossing is adequately visible
  - Pedestrian walk ways
  - Private roads
  - Other types of roads if the crossing is guarded by personnel.
  - Other exceptions



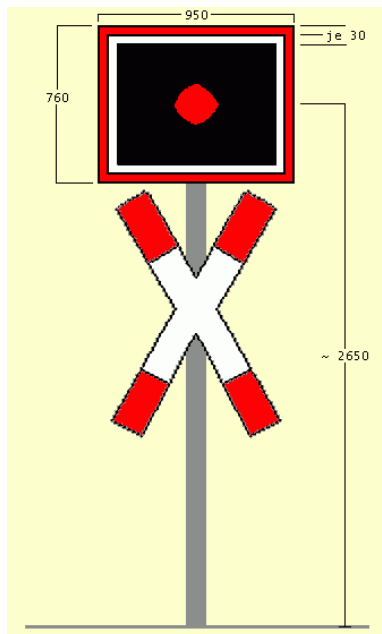
**Figure 1. St. Andrews Cross without Technical Safety Features.**

- In general crossings *must* be secured by
  - Signals (Figure 2) or blinking (flashing) lights (Figure 3), or
  - Signals or blinking (flashing) lights with half-barriers (stops traffic on driving side of the road only, Figure 4 and Figure 5), or
  - Signals with full barriers, or

- Full barriers, or
  - Crossing personnel.
- Other safety features may be certified by the regulatory authority.
- Signals or blinking (flashing) lights with half-barriers should no longer be used for new installations.
- Low volume crossings *may* be secured by
  - Adequate visibility.
  - Audible signals from the train, if there is no adequate visibility, and if the train speed limit at the crossing is 20 km/h (12.4 mph) (requires signs on the train route).
  - Audible signals from the train, if there is no adequate visibility, and if the train speed limit at the crossing of field and forest roads is 60 km/h (37.2 mph) (requires signs on the train route).
- Moderate volume crossings of single-track train routes *may* be secured by
  - Adequate visibility and audible signals from the train (requires signs on the train route).
  - Audible signals from the train, if there is no adequate visibility, and if the train speed limit at the crossing is 20 km/h (12.4 mph), with special permit by the regulatory authority (requires signs on the train route).
  - Audible signals from the train, if there is no adequate visibility, and if the train speed limit at the crossing of field and forest roads is 60 km/h (37.2 mph), with special permit by the regulatory authority (requires signs on the train route).
- Pedestrian crossings *must* be secured by
  - Pedestrian barriers (Figure 6)
  - On private roads with a train speed limit of 140 km/h (87 mph): by adequate visibility and closings (i.e., barriers or gates), or closings in combination with a speaker system to the responsible officer.
- If crossings have a higher than typical crossing volume on certain days, requirements for the higher volume category apply during these days.
- 
- Crossings of railroads and roads (2).
  - On new construction and upgrade projects, grade crossings are typically no longer allowable, even if the rail speed limit is less than 160 km/h (99.4 mph). The intention of the law is to reduce at-grade crossings over time to the extent feasible. These crossings may be simply closed or replaced by underpasses or overpasses.

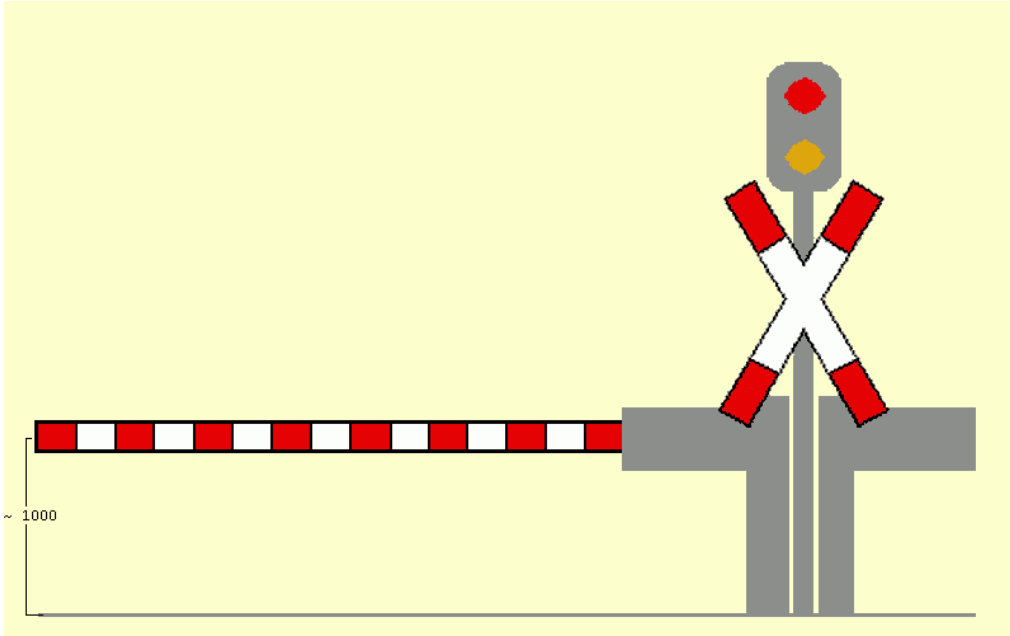


**Figure 2. St. Andrew's Cross with Signal.**

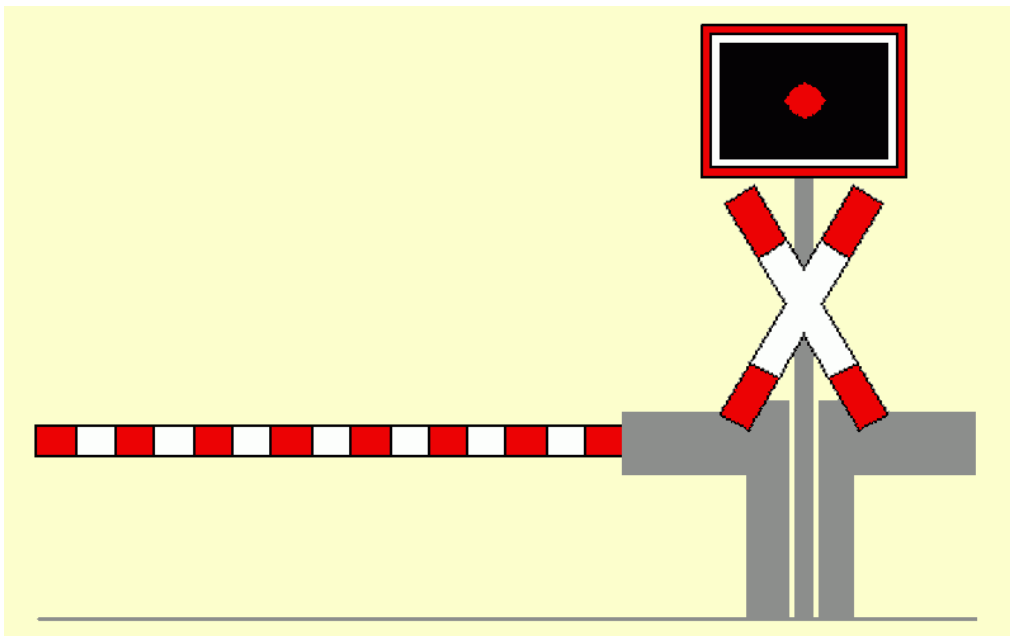


**Figure 3. St. Andrew's Cross with Blinking (Flashing) Lights.**





**Figure 4. St. Andrew's Cross with Signal and Half-Barriers.**



**Figure 5. St. Andrew's Cross with Blinking (Flashing) Lights and Half-Barriers.**



**Figure 6. Pedestrian Crossing with Barrier and Acoustic Warning for the Visually Impaired.**

## **References**

1. German National Railroad Construction and Operation Regulations, Section 11, Railroad Crossings. [http://www.gesetze-im-internet.de/ebo/\\_11.html](http://www.gesetze-im-internet.de/ebo/_11.html) (Eisenbahn-Bau und Betriebsordnung)
2. Crossings of Railroads and Roads (Gesetz ueber Kreuzungen von Eisenbahnen und Strassen (Eisenbahnkreuzungsgesetz)). <http://bundesrecht.juris.de/ebkrg/index.html>

---

## **Synthesis of Spanish and French Literature**

---

### **Overview/Abstract:**

Several documents from Spain and France were translated and reviewed.

## Exposure

Spanish and French regulations, recommendations, and standards rely primarily on the exposure (the product of annual average daily traffic and the daily trains). Exposure is literally translated from both French and Spanish as “(traffic) circulation moment,” respectively (“Moment/Momento de Circulation/Circulación”) and is abbreviated as MC in some of this section’s tables (Refs. 2-1, 2-2). France’s rules use exposure (MC) in addition to other factors such as train speed and sight distance (Refs. 2-6, 2-7).

## Sight Distance

In Spain, there are two ways to define sight distance. Actual sight distance (“visibilidad real”) is the distance between the intersection of the railroad and road medians, and the point where the approaching train starts to become visible from the mandatory stop sign on the road (Ref. 2-3). Actual sight distance of a grade crossing is the smallest of all “visibilidades reales” of all combinations of train and vehicular traffic directions.

Technical sight distance (“visibilidad técnica”) estimates the distance covered by a train at its maximum allowed speed during the time it takes for a vehicle to cross the entire at-grade crossing. It is calculated as:

$$Dt = 1.1Vm\sqrt{6.25 + n}$$

Where:

Dt: Technical sight distance of the crossing (meters)

Vm: Maximum train speed (km/h) at the crossing

n: Number of rail lines to cross.

France bases some protection standards on the sight distance definitions described below. The formulas are for a vehicle placed between 3.5 and 5.0m from intersection between the highway and the nearest rail line. The two main formulas are (Ref. 2-7):

$$R1 = 0.8F\sqrt{5.6 + n}$$

When “many” (actual number not defined in the regulations) vehicles longer than 14m clear the crossing at speeds less than 15km/h; or the crossing serves bovine herds larger than 8 animals, or ovine herds larger than 50 animals, the formula is:

$$R2 = F(3.4 + 0.7n)$$

Where:

F = Maximum train speed (km/h) at the crossing

n = Number of rail lines to cross.

## Grade Separation

In Spain, a Royal Decree requires either closing or grade-separating any crossing that has either exposure  $\geq 1500$ , or train speed  $\geq 160$  km/hr (approximately 100mph) (Ref. 2-4). This exposure threshold seemed too low to grade separate, although other references mention the same value. We asked our contacts in Spain, and they confirmed this low threshold, adding that they are due to concerns about the large number of long passenger trains prevalent all over Europe. Naturally, implementation of this decree is subject to available funds.

France does not have specific regulations about grade separation; decisions are made on a case-by-case basis. Grade separation should be considered when exposure is greater than 100,000 (Ref. 2-7).

## MINIMUM PROTECTION FOR AT-GRADE CROSSINGS

### Spain

Table 2-1 shows the minimum types of protection a function of exposure (MC) and train speed (Ref. 2-5). The minimum possible passive signage includes a mandatory stop sign at least 5m before the crossing.

**Table 2-1 Spain's Standards for Minimum At-Grade Crossing Protection (Ref. 2-4)**

Class	Thresholds	On the road / motorists	On the railroad / trains
A	$MC < 1000$	Crossbucks, stop sign, and no passing sign	Train horn 500m before the crossing
B	$1000 \leq MC < 1500$	Class A plus two alternating flashing red lights and bells, both activated 30s before the train arrives	Class A plus signal indicating whether or not the flashing lights are functional
C	$1000 \leq MC < 1500$ or Any MC if crossing is at a train station.	Gates, flashers, and bells. Lights and bells activated 45 sec before the train arrival, gates 60sec. Gates lower 6-8 sec after bells and lights and close completely in 10 sec.	Same as class B
D	$1000 \leq MC < 1500$ and Train speed $\leq 40$ km/hr	Class A plus a railroad agent to manually direct traffic.	Class A
E	Not specified	Classes B or C with protection activated by railroad agent in telephone contact with railroad control centers. Activation must	Same as Class C

Class	Thresholds	On the road / motorists	On the railroad / trains
		occur 60 sec before train arrival.	

**France’s Minimum Standards**

France classifies at-grade crossings into four categories, and specifies minimum protection for each category based on exposure, AADT, sight distance, minimum speed to clear crossing, and other factors (Ref. 2-7); see Table 2-2 for a synthesis of these regulations.

**Table 2-2 France's Four Categories of At-Grade Crossings (Ref. 2-7)**

Category	Characteristics	Minimum protection
1 <sup>st</sup>	<p>Vehicular traffic Public route Train speed ≤160km/h</p>	<p><i>Automated crossings</i> Automatic gates on the right side of the route in each direction Flashers on each direction Bells <i>Protected crossings</i> Vehicles: gates operated by rail agent Pedestrians: unprotected. If there is a pedestrian gate, pedestrians open it at their own risk.</p>
2 <sup>nd</sup>	<p>MC ≤3000 Train speed ≤140km/h Sight distance 600m</p>	<p>Crossbucks on each direction</p>
3 <sup>rd</sup>	<p>AADT &lt;10 Crossing clearable at 30km/h or less Sight distance 600m</p>	<p>Crossbucks on each direction</p>
4 <sup>th</sup>	<p>MC ≤5000 AADT ≤100 Sight distance 600m Pedestrian only Private crossings, pedestrian or vehicular</p>	<p>Crossbucks and stop signs on each direction  Pedestrian responsibility Owner's responsibility</p>

## France's Guidelines for Improving Active Crossings

France treats the issue on a case-by-case basis. Ref. 2-6 is an official publication providing guidelines to improve crossings already actively protected by gates, flashers, and/or other active protection and still deemed potentially dangerous. Figure 2-1 depicts an active crossing selected for improvements that is discussed in Ref. 2-6. This reference recommends weighing two possibilities: closing the crossing, or addressing accident causes.



(A train may hide another)

**Figure 2-7 Example of Active Protection in France**

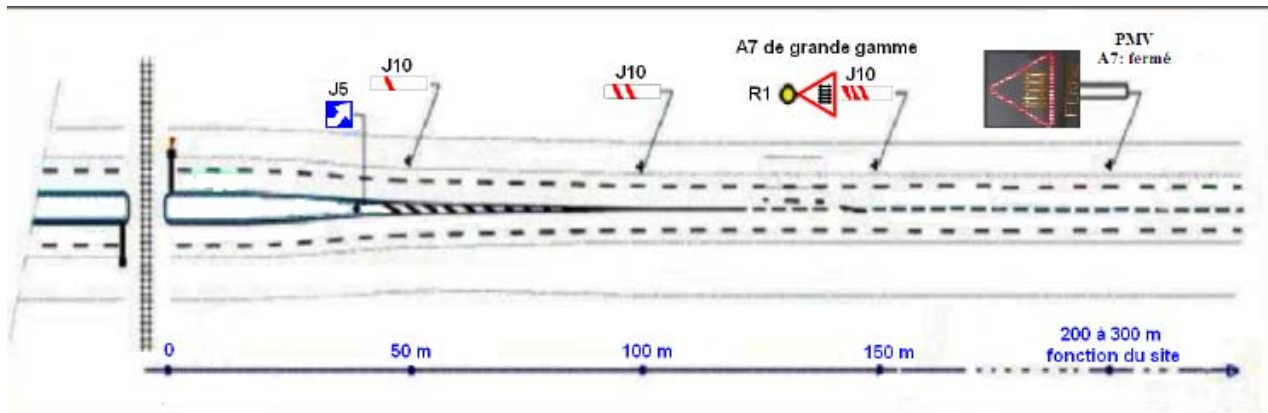
Source: ref. 2-6

Ref. 2-6 lists the five principal causes of accidents at active railroad crossings in France:

1. Automobiles approach crossing above posted speed limit;
2. Motorists drive around closed gates;
3. Poor visibility and legibility of the signs;
4. Queues from adjacent vehicular intersections spill back into the crossings; and
5. Crossing characteristics such sight distance, skid resistance, etc.

Improvement decisions are based on a survey of the principal causes of accidents at the crossing under consideration. Improvements consist of measures to address the cause(s). For example, install speed bumps for cause 1, provide law enforcement for cause 2, and so on.

Figure 2-2 shows the French schematic for full advance warning signs. The first sign on the highway (black rectangle) is a train-actuated variable message sign (VMS) indicating that the crossing is closed (“fermé”). Figure 2-3 depicts this VMS in detail.



**Figure 2-8 Fully Protected Crossing (Ref. 2-6)**



**Figure 2-9 VMS in Protected Crossing (Ref. 2-6)**

Note: “fermé” means closed.

## Conclusions

In terms of number of persons exposed to risk, highway-rail collisions are more problematic in Europe than in the USA due to the large number of passenger trains prevalent in that continent. Spain’s and France’s rules, regulations and laws concerning the signalization and grade separation of highway-rail crossings are highly influenced by this fact, which is not a concern in Texas. Moreover, the researchers could not find systematic approaches or methodologies to prioritize crossings for improvements.

## REFERENCES FOR THIS SECTION

- Ref 2-1: Ministro de Obras Públicas. *Instrucción 3.1-IC Características Geométricas. Trazado, y la Norma complementaria.*  
[http://www.carreteros.org/normativa/trazado/3\\_1ic/apartados/anexo.htm](http://www.carreteros.org/normativa/trazado/3_1ic/apartados/anexo.htm), Orden Ministerial 27-Dec-1999, updated 28-Jul-2010.
- Ref. 2-2: Service d’Etudes sur les Transports, les Routes et leurs Aménagements (Sétra). *Amélioration de la sécurité aux passages à niveau—Adaptation de l’infrastructure et de la*



*signalisation routière*. Note d'information. Série Circulation Sécurité Équipement Exploitation n° 128. France, December 2008.

- Ref 2-3 (sight distance definitions): [http://fmaf.castillalamancha.es/PEIT/PEIT\\_al\\_dia/PS\\_PNivel.htm](http://fmaf.castillalamancha.es/PEIT/PEIT_al_dia/PS_PNivel.htm)
- Ref 2-4: Spanish Government. Royal Decree 780/01, [http://www.carreteros.org/legislaciona/transportes/rlott/otros/rd\\_780\\_01.htm](http://www.carreteros.org/legislaciona/transportes/rlott/otros/rd_780_01.htm) , Madrid, July 6 2001.
- Ref. 2-5: Tranvia Portal, Ferropedia, [http://ferrocarriles.wikia.com/wiki/Paso\\_a\\_nivel](http://ferrocarriles.wikia.com/wiki/Paso_a_nivel)
- Ref. 2-6: Service d'Etudes sur les Transports, les Routes et leurs Aménagements (Sétra). *Amélioration de la Sécurité aux Passages à Niveau*. Note d'information, 128, December 2008.
- Ref. 2-7: Legifrance. Le Service Public de la Diffusion du Droit. *Arrêté du 18 Mars 1991 Relatif au Classement, à la Réglementation et à l'Équipement des Passages à Niveau*. Version Consolidée au 05 Juin 2008.

---

***The Australian Level Crossing Assessment Model. "ALCAM in Detail." February 2010.***

---

**Overview/Abstract:**

The Australian Level Crossing Assessment Model (ALCAM) is an assessment tool used to identify key potential risks at level crossings and to assist in the prioritisation of railway level crossings according to their comparative safety risk. It is used to support a rigorous defensible process for decision making for both road and pedestrian level crossings as well as a method to help determine the most cost effective treatments.

At the May 2003 Australian Transport Council (ATC) meeting all state and territory transport ministers agreed to adopt this innovative method of risk assessment. ALCAM is currently applied nation wide across Australia and New Zealand and is overseen by a committee of representatives from the various jurisdictions of these countries to ensure its consistency of development and implementation.

ALCAM is a complex scoring algorithm which considers each level crossings physical properties (characteristics and controls) including consideration of the related common human behaviours, to provide each level crossing with a "Likelihood Factor" score. This score is then multiplied by the level crossings "Exposure" score (a factor taking into account the volumes of Vehicles / Pedestrians & Trains) & finally multiplied by the Consequence score to give the ALCAM Risk Score. The ALCAM Risk Score, enables the comparison of the relative scores across level crossings within a given jurisdiction. This provides an overall risk rating for the level crossing however each individual hazard needs to be considered in its own right.

ALCAM Risk Score = Likelihood Factor x Exposure x Consequence

ALCAM produces both an overall comparative risk score for each level crossing as well as highlighting where specific potential hazards exist. It utilises likelihood bands as a preliminary means of determining the potential level of likelihood of an incident (High / Medium / Low) at a level crossing. ALCAM is then used in the determination of proposed treatments to address these

hazard areas. A total data management system is used (the Level Crossing Management System – LXM) to allow for the effective management of ALCAM data as well as other important information (such as accident history) which assists in the overall decision making process.

The model allocates weighted points to characteristics and controls at a level crossing to calculate a Likelihood Factor. The weightings applied have been determined through a series of workshops with contribution from experts including representatives from each mainland state of Australia and New Zealand covering expertise in road and rail engineering. In excess of 100 individuals, primarily from Australia's road and rail jurisdictions, with expertise collectively covering the areas of level crossing safety have been involved in the development of ALCAM from its conception in 1999 through to its continuing development and current use. The weightings take into account the likelihood and impact of a series of identified accident causal / human factors (accident mechanisms) and to what comparative degree each characteristic and control measure at a level crossing contributes to and/or impacts on these accident mechanisms.

### **Captured Information:**

Risk (effect of uncertainty on objectives) is widely known and accepted as the combination of both the likelihood (probability or frequency) of the occurrence of an event and the resulting consequence (outcome or impact) of that event once it has taken place.

### Likelihood Factor

The main calculation engine within ALCAM involves a matrix of weightings relating to how much each nominated characteristics at a level crossing influences the potential accident causal / human factors (accident mechanisms). The model also determines the impact the existing controls would have on these accident mechanisms. Significant and practical accident mechanisms, characteristics and controls have been considered and included through a process of seeking expert opinion through a series of workshops and interviews.

Accident Mechanisms include significant and practical accident causal factors associated with a collision between a level crossing user (motorist or pedestrian) and a train. They have been determined based on experience of accident history as well as expert knowledge.

Mechanisms have been grouped into the following categories:

- where the level crossing user is **unaware** of the dangerous situation.
- where the level crossing user is **unable to avoid** the dangerous situation.
- where the level crossing user is **unwilling** to recognise the dangerous situation.

Each of these mechanisms is then weighted based on a six by six probability matrix. A mechanism's weighting is calculated as the product of the occurrence and collision probability rating (weighting score between 1 and 36).

- **Occurrence Probability** – is a measure of how often the accident causal factor (accident mechanism) is likely to come into play.

- **Collision Probability** – is a measure of the likelihood of an incident if the accident causal factors (accident mechanism) comes into play.

Exposure (vehicles or pedestrians x trains)

Consequence

The Consequence factor (C) is determined as a relationship between an environmental factor and a train speed factor.

**Table 1 – Factors Affecting Consequence**

Factors affecting Consequences		Speed				
		0 - 60	61 -80	81 - 100	101 - 120	> 120
Environmental Factors	Index	1	2	3	4	5
Curve within stopping distance & Points in direction of travel	1	4	10	10	10	10
Road under bridge or river bridge	2	4	10	10	10	10
Steep embankment 3m +	3	4	4	10	10	10
Multiple track	4	3	4	10	10	10
School bus route	5	3	4	10	10	10
High proportion of heavy vehicles using the level crossing +10%	6	0.1	3	4	10	10
Tunnel within the stopping distance	7	0.1	3	3	10	10
Medium embankment	8	2	3	3	4	4
Curve within stopping distance & No other environmental concerns	9	1	2	3	3	3
Straight track + passengers	10	1	1	3	3	3
Straight track + freight only	11	0.1	1	1	3	3

Likelihood Bands

The ALCAM Likelihood Factor score in conjunction with Likelihood Bands is used to indicate the likelihood of an incident at the level crossing (High / Medium / Low) based on the exposure of each individual rail vehicle, road vehicle or pedestrian, which can then be used to assist in the determination of whether treatment is likely to be required at a particular level crossing. To identify whether the controls at a level crossing are likely to be considered adequate, ALCAM compares the Likelihood Factor with Likelihood Bands.

For a level crossing, where the Likelihood Factor falls in the High Likelihood Bands, treatment is generally considered as a high priority. Such treatment should be effective enough to reduce the proposed Likelihood Factor to a Low Likelihood Bands as well as addressing all risks to a level which is considered to be as low as reasonably practicable.

For a level crossing with a Likelihood Factor in the Medium Likelihood Band, a further assessment should be carried out to determine if there are treatments which can be employed which would be considered as low as reasonably practicable.

For a level crossing with a Likelihood Factor below the Low Likelihood Band, in most cases, is likely to be within acceptable limits and may not require to be prioritised for remedial works. A

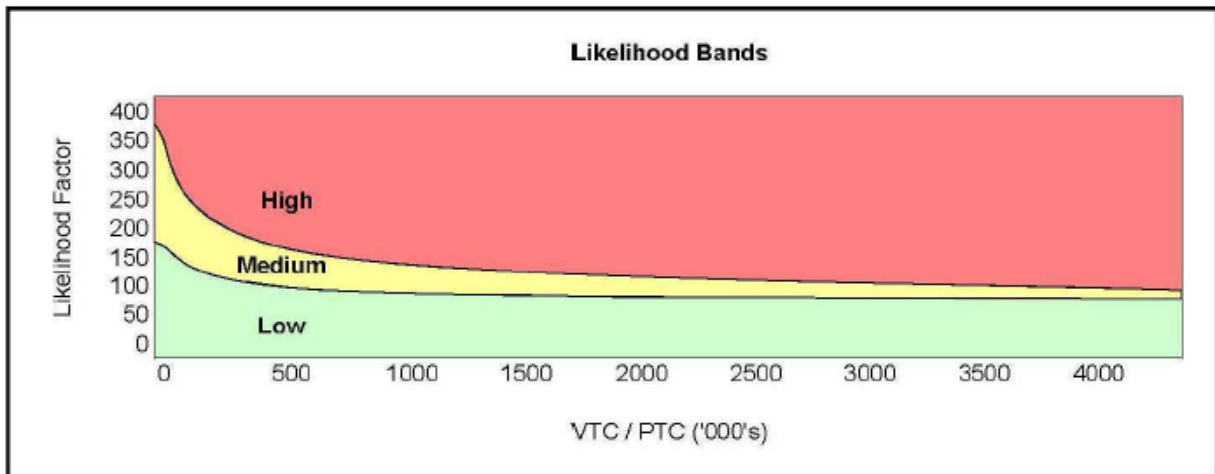
review of the hazards should be carried out on a regular basis on these sites to ensure there has been no significant change to the profile and that there are no specific individual hazards which require urgent attention (such as queuing, short stacking and standards compliance).

Figure 2 illustrates the different Likelihood Bands and action most likely to be required for each.

Figure 2 – Likelihood Bands

<b>HIGH</b>	<b>Safety improvement highly likely</b> - Factors have been identified that may require priority attention and are likely to require mitigation works to be undertaken to return to an acceptable level.
<b>MEDIUM</b>	<b>Safety improvement to be considered</b> - Factors have been identified that may require further assessment by road and railway entities. Remedial action may be required to address hazards.
<b>LOW</b>	<b>Safety at site to be monitored</b> - Indicative that appropriate control is in place and that remedial action may not be required. Ongoing monitoring by road and railway entities is required. (Consider Flags).

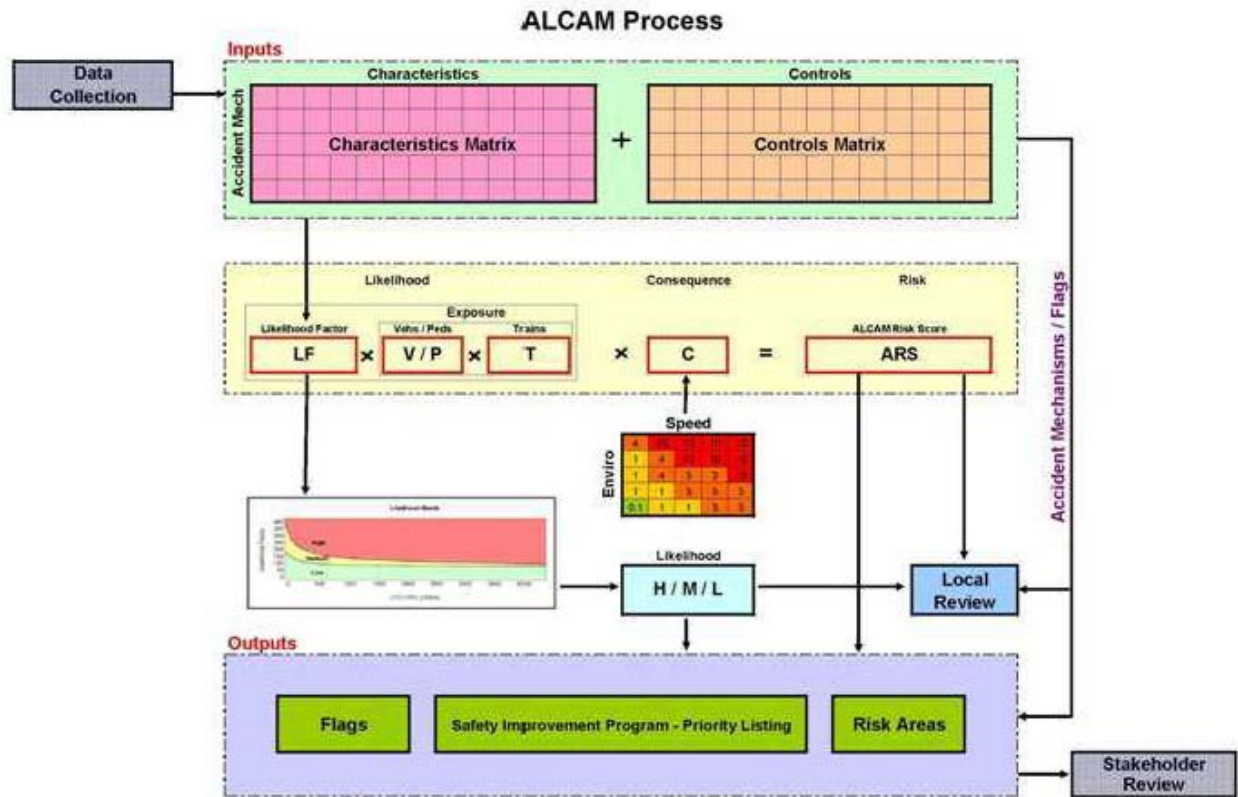
Figure 3 – Likelihood Bands (Graphic Representation)



### Cost Benefit

As a part of the determination of the optimal treatment to be implemented at an individual level crossing ALCAM can be used to provide an analysis of the theoretical reduction in risk of a proposal verses the estimated cost of that treatment. This then allows the comparison of a number of options in relation to their cost benefit. This information can then used at the stakeholder meeting to assist in the determination of the optimal solution.

Figure 4 – ALCAM Process



The above diagram (and the examples in Appendix A & B) illustrates the process and mechanics of ALCAM and the ALCAM formula. Starting at the top left of the diagram data is collected in the field and through a number of other sources including Road and Rail Authority traffic data information. This information flows into the ALCAM matrix and a Likelihood Factor (LF) is calculated dependant on the particular level crossings characteristics and controls and the weightings which have been developed for ALCAM. This LF is multiplied by the exposure (PT or VT-product of pedestrians or vehicles and trains) and finally by the Consequence Factor (C). This calculation results in what is known as the ALCAM Risk Score (ARS).

At the same time the LF is compared to the Likelihood Bands to give a preliminary indication of the level of likelihood of an incident occurring at the level crossing. Depending on the ARS, LF, Stakeholder analysis of site specific features and any other influencing factors decisions can then be made of the need for treatment and level of priority given to this treatment. This may be in the form of state-wide upgrade programs or through a local review between road and rail stakeholders.

#### Appendix C: Road level Crossings – Characteristics, Controls & Accident Mechanisms

##### Level Crossing Characteristics (risk factors - JW)

- Effectiveness of equipment inspection and maintenance
- Longest approach warning time

- Proximity to intersection control point
- Proximity to siding/shunting yard
- Proximity to station
- Possibility of short stacking
- Number of lanes
- Vulnerability to road user fatigue
- Presence of adjacent distractions
- Condition / Visibility of traffic control at level crossing
- Distance from advance warning to level crossing
- Conformance with Australian Standards (AS 1742.7)
- Heavy vehicle proportion
- Level of Service (vehicle congestion)
- Queuing from adjacent intersections
- Road traffic speed (approach speed 85<sup>th</sup> percentile)
- Train volume -two way (high / low)
- Seasonal / infrequent train patterns
- Slowest train speed at level crossing (typical)
- Longest train length at level crossing (typical)
- High Train Speed on approach to level crossing
- Number of operational rail tracks
- Condition of road surface on immediate approach/departure (not Xing panel)
- Level crossing panel on a hump, dip or rough surface
- S1 -advance visibility of level crossing from road
- S2 -approach visibility to train (vehicle approaching level crossing)
- S3 -visibility to train (vehicle stopped at level crossing)
- Road / Rail effected by sun glare
- Temporary visual impediments -sighting of level crossing / sighting of train

---

**Transport Canada, Transportation Development Centre. “Decision support model for prioritizing safety improvement programs.” Website. Available: <http://www.tc.gc.ca/eng/innovation/tdc-projects-rail-b-5532-1231.htm>.**

---

**Overview/Abstract:**

This project is currently in the second of two phases.

## **PHASE 1 - COLLISION FREQUENCY AND CONSEQUENCE MODEL**

The objective of phase 1 was to develop a model for estimating the potential risk of accidents at highway-railway grade crossings, taking into account a variety of control factors and conditions; and to identify “black spots”, i.e., high-risk crossings where safety intervention would be warranted. This project involved:

- a review of existing accident risk methodologies and development of a model for estimating the potential risk of accidents at highway-railway grade crossings, taking into account a variety of control factors and conditions
- a review of existing methods for identifying “black spots” and for prioritizing safety interventions
- development of a risk-based model for identifying “black spots” that incorporates objective measures of risk tolerance, to allow decision making
- application of the model to grade crossings across Canada, to develop a list of crossings (by region) where safety intervention would be warranted; and comparison of this list with regional grade crossing safety priorities
- estimation of the number of historical accidents that would have been flagged under the model in comparison with existing intervention programs; and comparison of regional and national clusters of “black spots” with the pattern of past safety interventions

A risk-based model for identifying highway-railway grade crossing black spots in Canada was developed. This model consists of two prediction components: collision frequency and collision consequence. A graphical approach was used to identify crossings with a higher risk of incidents. These crossings are referred to as “black spots”. The model was applied to Canadian inventory (IRIS) and collision occurrence (RODS) data for the period 1993-2001. Poisson and Negative Binomial (NB) frequency prediction expressions were developed for crossings with three types of warning devices (warning signs alone, flashing lights, and flashing lights with gates). Both Poisson and NB models were found to provide a good fit to the collision frequency data. A weighted consequence score was introduced to represent combined collision severity. The weights used in this combined consequence score were obtained from reported insurance claims for fatalities, personal injuries, and property damages. An NB expression was developed for the collision consequence model.

A list of black spot crossings was developed for the Canadian data, based on crossings where the expected number of collisions and/or expected severity score was exceeded at least 0.1% of the time. A Geographic Information System platform was developed for the Ontario region and used to illustrate the spatial pattern of expected and historical collision frequency and associated black spots.

## **PHASE 2 - DECISION SUPPORT MODEL FOR PRIORITIZING SAFETY IMPROVEMENT PROGRAMS**

The objective of phase 2 is to identify and assess cost-effective countermeasures for reducing risk at high risk highway-railway crossings, and to develop a decision-support tool for managing risk at high risk locations. This project will:



- develop a platform for accessing data on individual crossings, such as inventory, collision history, environment and spatial referencing, and link this data to appropriate models of inquiry for risk assessment and management
- investigate and document risk mitigation countermeasures currently available or likely to become available in the foreseeable future in terms of their implementation costs and expected effects
- improve the risk models developed in the previous phase of work to include variables to be used to evaluate the effectiveness of various countermeasures for reducing risk at grade crossings
- develop a decision support software tool for evaluating the cost effectiveness of various risk mitigation programs
- develop a mechanism for continuous updating of model structure and parameter estimates as new data on collisions and countermeasures become available

This project resulted in the development of *Grade X*, a web-based decision support software tool that can be used by railway and highway authorities to identify unsafe crossings and cost effective safety interventions. It provides an interface to a set of complex mathematical models and a repository of inventory and collision data for grade crossings in Canada. Risk models developed in the previous phase of this project have been refined to improve prioritization of crossings, to account for regional differences, and to apply a more consistent and precise methodology. The countermeasure assessment model builds on previous work in other areas, particularly highway design. It uses a variety of parameters to estimate how effective each potential countermeasure is likely to be for a given grade crossing.

The next development phase involved an in-service assessment of *Grade X* by Transport Canada personnel and continued development of the model related to countermeasure effectiveness. A training session was held in Ottawa in April 2007, for Transport Canada regional personnel.

---

**Transport Canada. “Financial Assistance: Grade Crossing Improvement Program (GCIP).” Website. Available: <http://www.tc.gc.ca/eng/railsafety/publications-46.htm>**

---

**Overview/Abstract:**

Safety at grade crossings is a primary focus of Transport Canada. Almost half of all railway-related deaths and injuries result from accidents at crossings. Government contributions are available to encourage and to assist safety improvements at public grade crossings that are under federal jurisdiction.

The Grade Crossing Improvement Program, funded under section 12 of the Railway Safety Act (RSA), is designed to provide up to 80 percent of the cost of a crossing improvement project. Funding for construction costs covers the safety improvements only, and does not include future maintenance costs. The authorities involved negotiate responsibility for the remaining costs. If they cannot reach agreement, the Canadian Transportation Agency may be asked to apportion the cost.



## **Captured Information:**

Potential highway rail crossing projects are most often identified through:

- an application from a road authority and/or railway company
- an inspection by a Transport Canada railway safety inspector, through regular monitoring or as a result of an accident
- a recommendation following an accident, including any made by the [Canadian Transportation Safety Board](#)
- a complaint concerning the safety of a crossing

Applications are categorized and available funds are allocated based upon the seriousness of the safety problem, and the potential for avoiding fatalities, injuries and damage. The following factors are used in prioritizing, and in assessing a grade crossing for funding:

- high exposure factors, such as annual average daily number of trains multiplied by annual average daily road traffic
- high train or road traffic speeds
- multiple track crossings
- severely restricted sightlines
- curved or angled approach, or nearby intersections that distract the motorist or impede the view of approaching trains
- a history of accidents

---

**Transport Canada. "Section 11: Grade Crossing Warning Systems." *Draft Technical Standards and Inspection, Testing and Maintenance Requirements*. Online. Available: <http://www.tc.gc.ca/eng/railsafety/guideline-rtd10-317.htm>.**

---

### **Overview/Abstract:**

Section 11 of the *Draft Technical Standards and Inspection, Testing and Maintenance Requirements* contains guidelines for improving grade crossing warning devices.

---

**U.S. Department of Transportation, Federal Highway Administration Office of Safety. *Railway-Highway Crossing Program 2010 Biennial Report to Congress*. January 4, 2010.**

---

### **Overview/Abstract:**

Section 130 of Title 23 of the United States Code authorizes the Railway-Highway Grade Crossing Program and describes the manner in which funds apportioned for this program may be used. This report assesses progress made during the FY 2008 and FY 2009 to implement the program and compares the current period to the prior reporting period as appropriate.

## **Captured Information:**

The Section 130 Program is intended to develop and implement safety improvement projects to reduce the number and severity of train collisions with motor vehicle and non-motor vehicle

traffic at public railway-highway grade crossings. The States and FHWA have well-established programs for evaluating the relative crash potential and the crash occurrence at crossings and determining the best manner in which to apply the Section 130 funds. These programs are dynamic and evolve as new technologies are developed, needs are addressed, and new safety concerns appear. While the specific details of the individual programs may vary, the overall process for implementing the programs is similar among the States.

State Section 130 programs typically consist of two components: protective devices and the elimination of hazards, at a 50-50 apportionment and obligation split. Protective devices include the signs, pavement markings, and signals that reduce risk by warning highway users of the presence of a crossing and of an approaching train, or requiring that drivers stop at the crossing. Example projects would include installation or replacement and upgrading of active warning devices (such as gates and lights), including track circuitry improvements and interconnections with highway traffic signals, crossing illumination, crossing surface improvements, and general sight improvements. Section 130(e) requires that at least half of the apportionment for each State be available for protective devices in that State. Hazard elimination treatments reduce risk by physically modifying the grade crossing, such as eliminating the crossing or improving crossing surfaces.

The Rail Safety Improvement Act of 2008 (RSIA), Section 202, requires each of the 10 States with the most railway-highway collisions during the last three years to develop a State Grade Crossing Safety Action Plan that is to be reviewed and approved by the FRA. The 10 States currently developing such plans are Alabama, California, Florida, Georgia, Illinois, Indiana, Iowa, Louisiana, Ohio, and Texas. These States were selected based upon their average number of collisions between 2006 and 2008. The plans are intended to identify specific solutions for improving safety at crossings such as crossing closures or grade separations and to focus on crossings that have experienced multiple crashes or that are at high risk for such crashes. These plans may be coordinated with other State or Federal planning requirements. Section 130 funding will likely be a key funding source identified by the States for implementing these plans.

In addition to the development of State Action Plans, the RSIA included the creation of model State legislation regarding sight distance at crossings and the encouragement of new technologies for grade crossing warning systems. Also, the RSIA amended 23 USC 130 to include new requirements for States and railroads to update inventories of warning devices at crossings as part of the national grade crossing inventory program maintained by the FRA.

The Rail Safety Improvement Act of 2008 (RSIA), Section 207, also authorized a new program of limited financial assistance for grade crossing safety:

- (1) To a maximum of three States each year for development or continuance of enhanced public education and awareness activities, in combination with targeted law enforcement, to significantly reduce violations of traffic laws at railway-highway grade crossings and to help prevent and reduce injuries and fatalities along railroad rights-of-way; and
- (2) To provide for priority railway-highway grade crossing safety improvements, including the installation, repair, or improvement of—
  - (A) Railroad crossing signals, gates, and related technologies, including median barriers and four quadrant gates;

- (B) Highway traffic signalization, including highway signals tied to railroad signal systems;
- (C) Highway lighting and crossing approach signage;
- (D) Roadway improvements, including railroad crossing panels and surfaces; and
- (E) Related work to mitigate dangerous conditions.

Funding authorization levels for (1) and (2) above were set at \$1.5 million each per year for FY 2010 through FY 2013; however, no funding has been appropriated for this provision of RSIA at the time this report was written.

## **ASSESSMENT OF GRADE CROSSING SAFETY AND SELECTION OF SAFETY IMPROVEMENT(S)**

This section discusses States' approaches for assessing grade crossing safety and selecting projects for Section 130 funds.

As noted in the introduction, States have developed comprehensive and effective railway-highway grade crossing programs and use past experience and new data to modify the programs as appropriate. In general, States prioritize crossings for improvements, select and install treatments, and evaluate treatment effectiveness. States typically use one or more of the following methods for assessing crossings and prioritizing projects:

- *Crash history.* Crossings with the highest crash experiences are given higher priority when selecting projects to implement.
- *Risk assessment.* Formulas have been developed by the Federal Railroad Administration and by individual States to predict crashes at crossings. These formulas account for characteristics such as vehicle and train traffic volumes, the design of the crossing, crash history, train speeds, and warning devices present. Another factor is whether school buses or trucks carrying hazardous materials use the crossing.
- *Corridor approach.* A State may implement a project to address all crossings along a rail corridor or portion of a corridor or give priority to a series of crossing projects in proximity to one another.

After performing risk assessment calculations or evaluating crashes histories and then prioritizing the crossings, States determine the best treatment and work to obligate funds to as many projects as they are able in a given fiscal year. Some common treatments include adding active warning devices to existing passive crossings and improving the pavement surface on the approaches to crossings. Many States also consider closing a crossing when determining appropriate treatments. In addition, safety professionals' judgment and input from other stakeholders (for example, railroads, city councils, or citizens) play a part in crossing assessment and project selection.

Table 2 provides a cost range comparison of the combined FY 2008 and FY 2009 Section 130 obligated projects in FMIS. Although only 41.3 percent of the projects to which Section 130 funds were obligated fall into the "less than \$125,000" per project range, the great majority, approximately 82.5 percent, cost less than \$250,000 per project, indicating that the projects where Section 130 funding is applied tend to be relatively low cost.

**Table 3. FY 2008 and FY 2009 Section 130 Projects by Obligation Amount Range\***

	Low (<\$125k)	Medium (\$125k – \$250k)	High (>\$250k)	Total Projects
Protective Devices	360	348	138	846
Elimination of Hazards	270	280	128	678
Total Projects by Range	630	628	266	1524
Percentage of Total Projects	41.3%	41.2%	17.5%	100%

\*Calculated from data reported in FMIS.

Table 3 documents the manner in which funds were obligated for various roadway types, or functional classification, during FY 2008 and FY 2009. Below is a general description of each functional class:

- *Arterials*: tend to be major thoroughfares and provide access between cities.
- *Collectors*: “collect” and distribute traffic to and from local roads and connect to arterial roadways.
- *Local roads*: provide access to individual properties and are frequently low-speed roads with low traffic volumes.

**Table 4. Projects and Funds Obligated by Functional Classification**

Classification	Obligations for Protective Devices	Obligations for Elimination of Hazards	Total Section 130 Obligations	Percentage of Total*
<b>FY 2008</b>				
Arterial	\$ 13,114,981	\$18,470,961	\$31,585,942	17.6%
Collector	11,207,524	12,974,542	24,182,066	13.5%
Local	49,287,372	30,676,845	79,964,217	44.5%
Unknown	16,921,021	27,037,800	43,958,821	24.5%
Total 2008	\$90,530,898	\$89,160,148	\$179,691,047	100%
<b>FY 2009</b>				
Arterial	\$27,235,777	\$39,447,866	\$66,683,643	23.6%
Collector	12,165,263	12,079,200	24,244,463	8.6%
Local	73,184,034	62,760,939	135,944,973	48.1%
Unknown	28,110,868	27,730,390	55,842,258	19.8%

Classification	Obligations for Protective Devices	Obligations for Elimination of Hazards	Total Section 130 Obligations	Percentage of Total*
Total 2009	\$140,695,942	\$142,019,396	\$282,715,338	100%
<b>FY 2008 and FY 2009 Total</b>	<b>\$231,226,840</b>	<b>\$231,179,544</b>	<b>\$462,406,385</b>	

The FHWA's FMIS data shows two broad categories of improvements: Protective Devices and Elimination of Hazards. State reports provide more detail on specific projects, including the type of treatment(s) involved in each project. Table 4 provides a summary of the detailed breakdown of treatment types that were presented in State reports. Not all States provided this information, so the total number of projects of each type is not known. The most common type of project is the installation of active warning devices, or upgrade of existing active warning devices. Since a driver encountering a train at a crossing is a relatively infrequent event, drivers typically do not expect they will meet a train at a crossing. Active devices, which warn drivers of the presence of a train or that a train is approaching, serve to overcome the increased risk associated with drivers potentially being less cautious than appropriate at crossings.

**Table 5. Project Types Summary**

Project Type	FY 2008		FY 2009	
	Number of States with at Least One Project	Total Projects	Number of States with at Least One Project	Total Projects
Crossing Approach Improvement	16	119	21	129
Crossing Warning Sign & Pavement Marking Improvement	8	98	10	59
Active Grade Crossing Equipment Installation or Upgrade	35	909	34	911
Visibility Improvement	1	1	0	0
Roadway Geometry Improvement	11	85	4	9
Grade Crossing Elimination	21	82	16	101
Crossing Inventory Update	6	7	5	6
Education or Enforcement	1	1	1	1
Other	5	19	4	9
<b>Total</b>		<b>1263</b>		<b>1211</b>

Project Type	FY 2008		FY 2009	
	Number of States with at Least One Project	Total Projects	Number of States with at Least One Project	Total Projects

*Note: Not all States provided information on treatment types in their annual reports, so this summary does not represent the national total of projects for the reporting period.*

States will often first consider eliminating a railway-highway grade crossing through closure (or grade separation) rather than installing an alternative treatment such as safety lights and gates. The FHWA and FRA encourage closing or consolidating crossings where appropriate, and Section 130(i) allows for monetary incentives for closing crossings. With this emphasis on reducing risk by eliminating crossings from the system, the number of public crossings has been decreasing and thereby reducing driver exposure to grade crossings.

In their annual Section 130 reports, States discuss the effectiveness of previous projects. This information gives an indication of the effectiveness of recent Section 130 projects. One of the methods that States used to evaluate the effectiveness of their grade crossing improvement projects is simple “before and after” studies. Individual before and after comparisons do not provide for a statistically reliable indication of the overall effectiveness of any one or a combination of treatments; however, when aggregated over all States, they do provide evidence of the effectiveness of the whole Section 130 program in reducing railway-highway crashes, and this aggregate comparison is discussed below.

The generally accepted minimum amount of time over which to gather data for evaluating the effectiveness of a treatment is three years. Therefore, States were asked to discuss projects implemented in 2004 or earlier in their FY 2008 reports, and 2005 or earlier in the FY 2009 reports. The crash experience during these three or more “after” years is compared to at least three “before” years, and a determination of effectiveness is made.

## FUTURE CONSIDERATIONS

Many of the approaches to grade crossing safety mentioned in the last reporting period remain, although the RSIA included several new provisions aimed at dealing with these problems. Several activities and developments that may help address additional challenges are summarized here:

- **New technologies.** In addition to improving data collection, new technologies are needed for improving safety at grade crossings. While there are many treatment options available, the continued occurrence of grade crossing crashes indicates the need to expand State safety toolboxes. New active warning devices, new devices for blocking crossings, and photo enforcement are examples. The distribution of information regarding new technologies as they are developed and approved for use, as well as information regarding State experiences with them, is an important component to the successful use of new devices. The RSIA specifically dealt with the need for new technology—

especially the need for lower-cost treatments at rural, passive grade crossings—allowing the U.S. Secretary of Transportation to approve the use of new treatments that show promise in improving the safety at these grade crossings.

- **Crossing inventory and data collection improvements.** A national database of grade crossings is maintained by FRA. States and railroads have been voluntarily updating the information in the database. Collecting data on the crossings is time- and resource-consuming and the inventory is often out of date; however, States rely on the inventories for safety assessments and project selection efforts. Many States note the need for more flexibility to use existing funding for staffing resources to aid in collecting data and for technologies that facilitate the data collection process. The RSIA has mandated that State and railroads periodically update the database. The results of this new statutory requirement have yet to be measured to determine how it will improve the quality and usefulness of the inventory in prioritizing projects for Section 130 funding.
- **New evaluation methodologies.** The successful reduction of grade crossing fatalities has resulted in low crash counts; without much data, it is difficult to identify trends in factors contributing to crashes, determine the most appropriate treatment, and evaluate the effectiveness of treatments beyond simple Before/After studies. States have been using risk assessment calculations to assess the existing conditions at crossings, and now States are beginning to use these procedures to evaluate the impact of treatments on safety at individual crossings. The FRA provides several risk evaluation tools on its web site, such as the “Web Based Accident Prediction System” (WBAPS) and the “GradeDec 2000,” which incorporate risk reduction factors for improvements other than the standard automated warning systems.

## MUTCD 2009

On December 16, 2009, the Federal Register posted the final rule for amendments related to the 2009 Edition of the Manual on Uniform Traffic Control Devices for Streets and Highways (MUTCD).<sup>1</sup> The effective date for this final rule was January 15, 2010. Revising the MUTCD is meant to further develop uniform application of traffic control devices, which the FHWA supports as a means to greatly improve traffic operations and roadway safety. Implementing the changes included in the new MUTCD could have a profound impact on future Section 130 project selection and available funding. Several of the amendments include changes to the MUTCD Part 8 regarding traffic controls for railway-highway grade crossings, which contains guidance and requirements for traffic-control devices at railway-highway grade crossings such as new pavement markings, advanced warning signs and upgraded traffic-control signs at the crossings. Section 130 funds are eligible for the installation of protective devices that improve safety including those that have reached the end of their service life. Below is a listing of some of the changes:

- *New Signal Warrant 9* - Provides for the installation of a traffic control signal at an intersection where a highway-rail grade crossing is adjacent to the intersection (Section 4C.10). It is intended to be utilized where traffic volumes are low enough not to warrant a

---

<sup>1</sup> Federal Register, Vol. 74, No. 240, Wednesday, December 16, 2009, Part II, Department of Transportation, Federal Highway Administration 23 CFR Part 655, National Standards for Traffic Control Devices; the *Manual on Uniform Traffic Control Devices for Streets and Highways*; Revision; Final Rule.

traffic control signal in existing warrants 1 through 8. It provides a means to clear vehicles from the track while a train is approaching through interconnection and preemption.

- *YIELD or STOP Signs* – The 2009 MUTCD requires that a YIELD or STOP sign be installed at all passive railway-highway grade crossings, either on the same sign post or on a separate sign post. An engineering study is required to justify the placement of a STOP sign at a railway-highway grade crossing. The Final Rule indicates that an engineering study would be required for those crossings that already have STOP signs but do not have a study on file; perhaps placed by engineering judgment instead of an engineering study. The target compliance date established by the FHWA is listed as December 31, 2019, or when adjustments are made to the individual grade crossing and/or corridor, whichever occurs first. It is indicated that the compliance date is designated because “relying on the systematic upgrading processes that highway agencies typically use to replace existing signs at the end of their service lives would result in a[n] excessively long time period for installation of YIELD or STOP signs at existing passive grade crossings.”<sup>2</sup>
- *Emergency Notification Sign* – The 2009 MUTCD provides a standard for the minimum amount of information to be included on an emergency notification sign located at railway-highway grade crossings. This should be coordinated with the RSIA mandate requiring that railroads implement emergency notification systems, including signs, for all crossings.
- *Stop Lines* – The 2009 MUTCD requires the use of stop lines on paved roadways at railway-highway grade crossings that are equipped with active warning devices.
- *Gate Arm Stripes* – The 2009 MUTCD requires the stripes on all active crossing gate arms to be vertical, rather than 45-degree diagonal.
- *Pathway-Rail Grade Crossings* – A new chapter title, “Chapter 8D. Pathway Grade Crossings” addresses shared-use paths and other similar facilities that cross railroad or light rail transit tracks at grade. One requirement in this chapter is the requirement of the placement of a crossbuck assembly on each approach to a pathway grade crossing.

---

**USDOT, FHWA, Highway/Rail Grade Crossing Technical Working Group (TWG),  
*Guidance on Traffic Control Devices at Highway-Rail Grade Crossings, November 2002.***

---

**Overview/Abstract:**

The Executive Summary indicates that the report is intended to provide guidance to assist engineers in selection of traffic control devices or other measures at highway-rail grade crossings. It is not to be interpreted as policy or standards. Any requirements that may be noted in this guidance are taken from the Manual on Uniform Traffic Control Devices (MUTCD) or other document identified by footnotes. These authorities should be followed. This guide merely tries to incorporate some of the requirements found in those documents. A number of measures

---

<sup>2</sup> Federal Register, Vol. 74, No. 240, Wednesday, December 16, 2009, Part II, Department of Transportation, Federal Highway Administration 23 CFR Part 655, National Standards for Traffic Control Devices; the *Manual on Uniform Traffic Control Devices for Streets and Highways*; Revision; Final Rule. Page 66849.



are included which may not have been supported by quantitative research, but are being used by States and local agencies. These are included to inform practitioners of an array of tools used or being explored.

The goal is to provide a guidance document for users who understand general engineering and operational concepts of highway-rail grade crossings. The Guide serves as a reference to aid in decisions to install traffic control devices or otherwise improve such crossings. Additional references are provided as resource for further information.

---

## Extraction of Warrants and Criteria for Highway-Rail Grade Crossings

---

This section pulls criteria and warrants from the literature review.

### CLOSURE

---

#### **Florida Department of Transportation. *Rail Manual*. Topic No. 725-080-002, March 2000.**

---

From A.5.1 Consolidation Candidates

Any highway railroad grade crossing having some of the following characteristics is a candidate for consolidation:

- Less than 2,000 vehicles per day.
- More than two (2) trains per day.
- Alternate highway railroad crossing (at grade or separated) within 1300 feet (400 m) that is accessible with:
  - Less than 5,000 vehicles per day for a two (2) lane highway.
  - Less than 15,000 vehicles per day for a four (4) lane highway.
- Railroad crosses the highway at an extreme skewed angle.
- The highway does not serve as an alternate route for emergency vehicles.
- Five or more highway railroad grade crossings within any one (1) mile (1.6 km) section of a main line track.

---

#### **Ogden, Brent. *Railroad-Highway Grade Crossing Handbook – Revised Second Edition*. U.S. Department of Transportation, Federal Highway Administration, 2007.**

---

From Closure (pp. 78-82)

*The Traffic Control Devices Handbook* suggests criteria that may be used for crossing closure.

Criteria for crossings on branch lines include:

- Less than 2,000 average daily traffic (ADT).
- More than two trains per day.
- Alternate crossing within 0.25 mile that has
  - less than 5,000 ADT if two lanes or less than
  - 15,000 ADT if four lanes.

Criteria for crossings on spur tracks include:

- Less than 2,000 ADT.
- More than 15 trains per day.
- Alternate crossing within 0.25 mile that has
  - less than 5,000 ADT if two lanes or less than
  - 15,000 ADT if four lanes.

Criteria for crossing on mainline:

- Any mainline section with more than five crossings within a 1-mile segment.

From *Technical Working Group Guidance*, highway-rail grade crossings should be considered for closure and vacated across the railroad right of way whenever one or more of the following apply:

- a) An engineering study determines a nearby crossing otherwise required to be improved or grade separated already has acceptable alternate vehicular access, and pedestrian access can continue at the subject crossing, if existing.
- b) On a life-cycle cost basis, the cost of implementing the recommended improvement would exceed the cost of providing an acceptable alternate access.
- c) If an engineering study determines any of the following apply:
  - a. FRA Class 1, 2, or 3 track with daily train movements:
    - i. AADT less than 500 in urban areas, acceptable alternate access across the rail line exists within 0.4 km (one-quarter-mile), and the median trip length normally made over the subject crossing would not increase by more than .8 km (one-half-mile).
    - ii. AADT less than 50 in rural areas, acceptable alternate access across the rail line exists within .8 km (one-half-mile), and the median trip length normally made over the subject crossing would not increase by more than 2.4 km (1.5 miles).
  - b. FRA Class 4 or 5 track with active rail traffic:
    - i. AADT less than 1,000 in urban areas, acceptable alternate access across the rail line exists within .4 km (one-quarter-mile), and the median trip length normally made over the subject crossing would not increase by more than 1.2 km (three-quarters-mile).
    - ii. AADT less than 100 in rural areas, acceptable alternate access across the rail line exists within 1.61 km (1 mile), and the median trip length normally made over the subject crossing would not increase by more than 4.8 km (3 miles).
  - c. FRA Class 6 or higher track with active rail traffic, AADT less than 250 in rural areas, an acceptable alternate access across the rail line exists within 2.4 km (1.5 miles), and the median trip length normally made over the subject crossing would not increase by more than 6.4 km (4 miles).
- d) An engineering study determines the crossing should be closed to vehicular and pedestrian traffic when railroad operations will occupy or block the crossing for extended periods of time on a routine basis and it is determined that it is not physically or economically feasible to either construct a grade separation or shift the train operation to another location. Such locations would typically include:
  - a. Rail yards.
  - b. Passing tracks primarily used for holding trains while waiting to meet or be passed by other locations where train crews are routinely required to stop their

trains because of cross traffic on intersecting rail lines or to pick up or set out blocks of cars or switch local industries en route.

- c. switching leads at the ends of classification yards.
- d. where trains are required to “double” in or out of yards and terminals.
- e. in the proximity of stations where long distance passenger trains are required to make extended stops to transfer baggage, pick up, or set out equipment or be serviced en route.
- f. locations where trains must stop or wait for crew changes.

## INSTALLATION OF STOP SIGNS & UPGRADE FROM PASSIVE TO ACTIVE

**Cairney, Peter, Gunatillake, Thanuja, and Wigglesworth, Eric. ARRB Transportat Research. *Reducing Collisions at Passive Railway Level Crossings in Australia*. Austroads Publication No. AP-R208/02. Published by Austroads Incorporated, Sydney, Australia, 2002.**

### 14 Appendix A: Comparison of Warrants for Level Crossing Protection – Australia and New Zealand

JURISDICTION	Western Australia	Queensland	New South Wales	Tasmania	South Australia	New Zealand
Responsibility	Assessment by MRWA – jointly by Rail authority and MRWA. MRWA funds improvements on public roads and shares maintenance costs with Rail Authority Removing visibility impediments – local government and rail authority.	Main Road Queensland determine warrants –	Rail Authority responsible for - installing & maintaining signs, signals, booms etc & maintaining road to edge of sleepers. RTA installs signs and markings on approaches on major roads. LG on local roads. LG is responsible for street lighting. RTA & Rail Auth jointly determine protection needs. RTA funds ALL work on State & Regional roads. On local roads RTA funds 2/3	Level Crossing Warning Committee (LCWC) determines level of protection required. Rail authority to provide position signs and maintain clear visibility in rail reserve. road authority the rest of the visibility triangles. DIER Tasmania responsible for advance signs and road markings on all roads. LCWC raise sightline issues on private property/road reserves with road owner.	Transport SA funding and assessment. Criteria determined by State Level Crossing Safety Committee Removing visibility impediments – local government and rail authority.	Responsibility for regulating protection standards at level crossings rests with the Land Transport Safety Authority. There is a statutory requirement to consult with operators and other stakeholders.
Position Signs	Max of 80km/h train speed Visibility triangles 5 seconds safety margin 3 seconds reaction time plus addition of 0.5seconds if – - less than 2 trains per day - poor road conditions Other safety considerations – stacking, train horn, lighting, train headlights where pedestrians	Visibility triangles 5 metre safety margin Reaction time 2.5 seconds	Visibility triangles, 5 seconds safety margin. Reaction time 2.5 seconds.	Visibility triangles and 5m clearance per NSW & Old angles less than 35 degrees left and 30 degrees right. Reaction time 2.5 seconds Safety margin 5m clearance	Minimum angle (35 left, 30 right) Visibility triangles 2.5 seconds reaction time	Visibility triangles, 65m visibility required on roads with operating speeds 60 km/h or less, 120m visibility required in all other locations

JURISDICTION	Western Australia	Queensland	New South Wales	Tasmania	South Australia	New Zealand
Stop Signs	Max train speed 100km/h Visibility triangles 5 second safety margin Other safety considerations – stacking, train horn, lighting, train headlights where pedestrians	Visibility triangles 5 metres safety clearance margin	Visibility triangles, 5 seconds safety margin.	Visibility triangles 5 metres safety clearance margin	Failure to satisfy position signs Visibility triangles 6metre safety margin Minimum angle (as per all States)	When sight distance along the railway from the road approach is so restricted that the safe approach speed is 20 km/h or less, Stop control is warranted. This may not apply at crossings with high volumes of heavy or long vehicles (eg B doubles).
Flashing Lights	Failure to meet visibility for stops and can't be improved. Conflict (weighted to account for high speed trains and vehicles) > 14,000 (trains per week x AADT) Benefit/cost considerations (>2) Not withstanding conflict - may be installed because important road – eg highway. Other safety considerations as above plus road must be sealed for 50m each side, advance amber warning lights may be used for road trains etc	Failure to meet visibility for stops and can't be improved. Conflict (vehicles per day x trains per week) single track – Urban areas 300,000 Rural areas 50,000 Benefit/cost analysis support required	Failure to meet visibility for stops and can't be improved. Need for Flashing Lights is based on Conflict number (weekly trains x daily traffic) based on road speed and number of tracks – Single track 60k zone – 50,000 Single track 100k zone – 45,000 Multiple track 60k zone - 80,000 Multiple track 100k zone – 70,000	Conditions for Stop signs are not met or conflict > 14,000 single track or >12,000 multiple track. Or crossing on highways or main arterial roads, or situations where special safety problem, eg shunting - each case considered on its merits.	Failure to meet visibility for stops and can't be improved. Conflict > 70,000 for single lines and > 60,000 for multiple lines Benefit/cost considerations (>2) Consideration of special situations such as shunting Gongs/bells with every FL May use normal intersection signals where crossing next to road traffic light intersection (see below) May use overhead signals	Failure to meet visibility for stop signs and can't be improved. Conflict > 70,000 for single lines and > 60,000 for multiple lines Benefit/cost considerations (>2) Consideration of special situations such as shunting Gongs/bells with every FL May use normal intersection signals where crossing next to road traffic light intersection (see below) May use overhead signals
Pedestrian Protection	Mazes, paths, bells, signs	No specific mention of pedestrian treatments	Based on AS1742.7 and experience. Paths, mazes, bells and pedestrian booms as required	Improvements – paths, bell/gongs mazes per AS 1742.7	Mazes, paths for pedestrians	Footways with fencing, signage, pedestrian stop line should be marked at a distance of three metres from the nearest rail to indicate a safe position for pedestrians to wait for the passage of trains, mazes.

### **7-3.02 At-Grade Crossings**

#### **7-3.02(a) Selection Guidelines for Warning Devices**

Warning devices will be warranted at all highway-railroad crossings where grades are not separated. Select the type of warning device according to the following:

1. General. At a minimum, provide reflectorized crossbucks, pavement markings, and advance warning signs as indicated in the *Illinois Manual on Uniform Traffic Control Devices* at all crossings.
2. Flashing Signals. Install flashing signals at crossings where the warrants for gates are not met and where the expected crash frequency equals or exceeds 0.02. Use Equation 7-3.1 and the factors in Figure 7-3.A to determine the expected crash frequency.

$$ECF = A \times B \times T \text{ (Equation 7-3.1)}$$

Where:

ECF = Expected Crash Frequency

A = Traffic factor, see Figure 7-3.A

B = Component factor, see Figure 7-3.A

T = Current number of trains per day

3. Cantilevered Flashing Signals. Use cantilevered flashing signals, in addition to other warning devices, on multilane highways that qualify for active warning devices and where there is the possibility of a truck blocking the view of the roadside signals. Also, consider providing cantilever signals at high-frequency crash locations that possibly could be improved by more visible signals.

A Factors

VEHICLES PER DAY (10-YR. ADT)	FACTOR
250	0.000347
500	0.000694
1000	0.001377
2000	0.002627
3000	0.003981
4000	0.005208
5000	0.006516
6000	0.007720
7000	0.009005
8000	0.010278
9000	0.011435
10000	0.012674
12000	0.015012
14000	0.017315
16000	0.019549
18000	0.021736
20000	0.023877
25000	0.029051
30000	0.034757

B Factors — Basic Values for Existing Devices

Components	Basic Value Adjustments
Crossbucks, traffic volume less than 500 vehicles per day	3.89
Crossbucks, urban	3.06
Crossbucks, rural	3.08
Stop signs, traffic volume less than 500 vehicles per day	4.51
Stop signs	1.15
Wigwags	0.61
Flashing lights, urban	0.23
Flashing lights, rural	0.93
Gates, urban	0.08
Gates, rural	0.19

**CRASH FREQUENCY FACTORS  
(Highway-Railroad Grade Crossings)**

Figure 7-3.A



### **Criteria for Installation of Post-Mounted Flashing-Light Signals**

A system of post-mounted flashing-light signals may be used in lieu of existing Crossbuck signs, STOP or YIELD signs, bells or manual warning at a highway-railroad grade crossing when any of the following conditions are met or exceeded:

- 1a. The New Hampshire Index exposure factor exceeds 4,000 or the National Cooperative Highway Research Program Report 50 Accident Prediction Formula calculation exceeds 0.02 (See Appendix A for indices and formulae) or the crossing has train speeds equal to or in excess of 65 mph\*, and;
- 1b. The highway approach sight distance (dH) or the triangular quadrant sight distance are restricted for the actual train and vehicular traffic speeds in accordance with the table given in Appendix B.
2. The crossing has had two or more car/train crashes in the last five years which may be susceptible to correction by the installation of flashing-light signals.

Criteria 1a and 1b are used together with the and condition.

Criteria 2 may be used independently

\*Note: a Federal Railroad Administration report dated August 2000 regarding the assessment of risk for high-speed rail grade crossings indicates that "... risk to highway users saturates at train speeds around 65 mph...."

When a highway-railroad grade crossing with Crossbuck signs, STOP or YIELD signs, bells, or manual warning does not meet the above criteria, but the railroad and road authority agree that the crossing should be upgraded to post-mounted flashing-light signals, the Department may concur with the request.

---

## **Spain and France**

---

### **At-Grade Crossings**

#### *Spain*

Table 1 shows the minimum type of protection, recommended as a function of MC (see definitions). The minimum possible passive signage includes a mandatory stop at least 5m before the crossing (ref. 5).

**Table 6 Spain's Standards for Minimum At-Grade Crossing Protection**

<b>Class</b>	<b>Thresholds / Rules</b>	<b>On the road / motorists</b>	<b>On the railroad / trains</b>
A	MC<1000	Crossbucks, Stop sign, and No passing sign	Honk 500m before the crossing
B	1000≤MC<1500	Class A plus: Two alternating flashing red lights and bells, both activated 30s before the train arrives.	Class A plus: Signal indicating whether or not the flashing lights are functional
C	1000≤MC<1500 or Any MC if crossing is at a train station.	Gates, flashers, and bells. Lights and bells activated 45 seconds before the train arrival, and gates 60seconds. Gates lower 6-8 seconds after bells and lights, and take no longer than 10 seconds to close completely.	Same as class B
D	1000≤MC<1500 and train speed≤40km/hr	Class A, plus a railroad agent to manually direct traffic to stop for the train.	Class A
E	No specification	Classes B or C, but protection activated by railroad agent in telephone contact with railroad control centers. Activation must occur 60 seconds before train arrival.	Same as Class C

*France's Minimum Standards*

France classifies at-grade crossings into four categories, and specifies minimum protection for each category based on MC, AADT, sight distance, and minimum speed to clear crossing (ref. 6). See table 2 in the next page for a synthesis of these regulations.

**Table 7 France's Four Categories of At-Grade Crossings (ref. 2)**

<b>Category</b>	<b>Characteristics</b>	<b>Minimum protection</b>
1 <sup>st</sup>	Vehicular traffic Public route Train speed ≤160km/h	<i>Automated crossings</i> Automatic gates on the right side of the route in each direction Flashers on each direction Bells <i>Protected crossings</i> Vehicles: gates operated by rail agent Pedestrians: unprotected. If there is a pedestrian gate, pedestrians open it at their own risk.

2 <sup>nd</sup>	CM≤3000 Train speed ≤140km/h Sight distance 600m	Crossbucks on each direction
	AADT<10 Crossing clearable at 30km/h or less Sight distance 600m	Crossbucks on each direction
	CM≤5000 AADT≤100 Sight distance 600m	Crossbucks and stop signs on each direction
3 <sup>rd</sup>	Pedestrian only	Pedestrian responsibility
4 <sup>th</sup>	Private crossings, pedestrian or vehicular	Owner's responsibility

---

**Transport Canada. "Section 11: Grade Crossing Warning Systems." *Draft Technical Standards and Inspection, Testing and Maintenance Requirements*. Online. Available: <http://www.tc.gc.ca/eng/railsafety/guideline-rtd10-317.htm>.**

---

**GRADE CROSSING WARNING SYSTEMS**  
**SECTION 11 - GRADE CROSSING WARNING SYSTEMS**

**Vehicles**

11.1 Unrestricted grade crossings for vehicular use shall have a grade crossing warning system if:

- (a) (i) the forecast cross-product is 1,000 or more; or
- (ii) the grade crossing does not include a sidewalk and the maximum railway operating speed exceeds 80 mph; or
- (iii) the grade crossing includes a sidewalk and the maximum railway operating speed exceeds 60 mph; or
- (iv) there are two or more tracks and trains may be passing one another; or
- (v) the sightlines or alternative measures specified in Section 8-3 are not provided, including where trains, engines, railway cars, or other railway equipment, standing or stored, may obscure driver or pedestrian sightlines of a train approaching the grade crossing.

Alternatively, if the grade crossing is located where trains stop before entering the grade crossing, train movements over the grade crossing may be manually protected, or traffic signals may be installed in lieu of a grade crossing warning system. The normal display of such traffic signals shall be a green light for road traffic, while trains will be required to stop until given an indication that they are to proceed.

- (b) the maximum railway operating speed exceeds 15 mph, there is a Stop Sign or traffic signals controlling vehicular traffic on that part of the road leading away from the grade crossing, and the distance between the front of a vehicle in the first stopped position at the Stop Sign or traffic signals and a rail in the grade crossing surface is:
  - (i) less than 30 m for a Stop Sign (refer to Figure 11-1 a); or
  - (ii) 30 m or more for a Stop Sign, unless a traffic study indicates that queued traffic will not encroach within 2.4 m of the rail nearest the road intersection (refer to Figure 11-1, a); or
  - (iii) less than 60 m for traffic signals, (refer to Figure 11-1 b); or
  - (iv) 60 m or more for traffic signals, unless a traffic study indicates that queued traffic will not encroach within 2.4 m of the rail nearest the road intersection (refer to Figure 11-1, b).

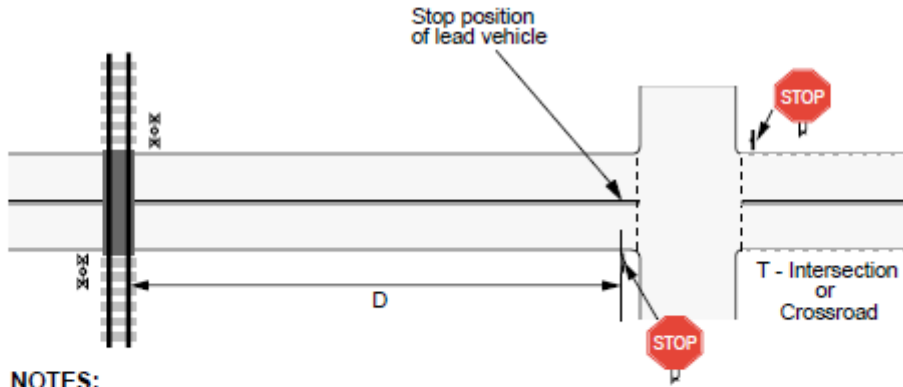
### **Pedestrian or Cyclist Paths**

11.2 Unrestricted grade crossings for pedestrian or cyclist use only, shall have a grade crossing warning system where:

- (a) the maximum railway operating speed exceeds 60 mph; or
- (b) the maximum railway operating speed exceeds 15 mph and there are two or more tracks at the grade crossing where trains may be passing one another.

**Figure 11-1: Proximity of Grade Crossing Warning Systems to Stop Signs and Traffic Signals**

**a) NEAR STOP SIGNS**

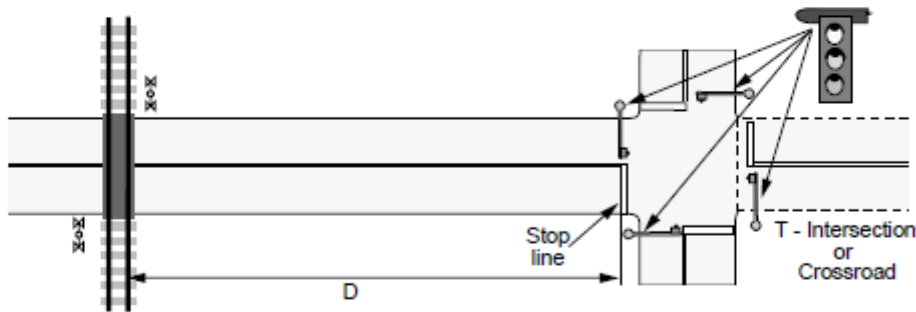


**NOTES:**

Where the maximum railway operating speed exceeds 15 mph:

- if D is less than 30 m, a grade crossing warning system including gates is required;
- if D is 30 m or greater, a grade crossing warning system including gates is required unless a traffic study indicates that traffic will not normally queue to within 2.4 m of the rail nearest the road intersection. For grade crossings or road intersections nearby an existing grade crossing, where the maximum railway operating speed exceeds 15 mph:

**b) NEAR TRAFFIC SIGNALS**



**NOTES:**

For grade crossings or road intersections nearby an existing grade crossing, where the maximum railway operating speed exceeds 15 mph:

- if D is less than 60 m, a grade crossing warning system including gates is required;
- if D is 60 m or greater, a grade crossing warning system including gates is required unless a traffic study shows that traffic will not queue to within 2.4 m of the rail nearest the road intersection.

Drawing not to scale

---

**USDOT, FHWA, Highway/Rail Grade Crossing Technical Working Group (TWG),  
Guidance on Traffic Control Devices at Highway-Rail Grade Crossings, November 2002.**

---

**STOP and YIELD SIGNS**

The Intermodal Surface Transportation Efficiency Act of 1991 (ISTEA) (Public Law 102-240; 105 Stat 1914; December 18, 1991) required that the FHWA revise the MUTCD to enable State

or local governments to install STOP or YIELD signs at any passive highway-rail grade crossing where two or more trains operated daily. In response, the FHWA published a final rule in the Federal Register (57 FR 53029), which incorporated the new standards into the MUTCD. This final rule, published in March 1992, was effective immediately.

The FHWA and the FRA published a memorandum containing guidelines for when the use of STOP or YIELD signs is appropriate. According to the jointly-developed document, "it is recommended that the following considerations be met in every case where a STOP sign is installed:"

1. Local and/or State police and judicial officials commit to a program of enforcement no less vigorous than would apply at a highway intersection equipped with STOP signs.
2. Installation of a STOP sign would not occasion a more dangerous situation (taking into consideration both the likelihood and severity of highway-rail collisions and other highway traffic risks) than would exist with a YIELD sign.

According to this memorandum, any of the following conditions indicate that the use of a STOP sign might reduce risk at a crossing:

1. Maximum train speeds equal, or exceed, 48 km/h (30 mph).
2. Highway traffic mix includes buses, hazardous materials carriers and/or large (trash or earth moving) equipment.
3. Train movements are 10 or more per day, five or more days per week.
4. The rail line is used by passenger trains.
5. The rail line is regularly used to transport a significant quantity of hazardous materials.
6. The highway crosses two or more tracks, particularly where both tracks are main tracks or one track is a passing siding that is frequently used.
7. The angle of approach to the crossing is skewed.
8. The line of sight from an approaching highway vehicle to an approaching train is restricted such that approaching traffic is required to substantially reduce speed.

The memorandum also states, however, that the above conditions should be weighed against the possible existence of the following factors:

1. The highway is other than secondary in character. Recommended maximum of 400 ADT in rural areas, and 1,500 ADT in urban areas.
2. The roadway is a steep ascending grade to or through the crossing, sight distance in both directions is unrestricted in relation to maximum closing speed, and heavy vehicles use the crossing.

## UPGRADE FROM LIGHTS TO LIGHTS AND GATES

---

**Florida Department of Transportation. *Rail Manual*. Topic No. 725-080-002, March 2000.**

---

**Rule 14-46.003, Florida Administrative Code** details the conditions under which gates are required to be installed at a new and existing highway railroad grade crossing. The following conditions will require gates:

- Multi lane highway.
- Multiple mainline railroad tracks including passing tracks.
- Multiple tracks at or adjacent to the highway railroad grade crossing which may be occupied by train resulting in the view obstructing the movement of another train approaching the highway railroad grade crossing.
- High speed train operation greater than 65 mph (110 km/h) or commuter train operation greater than 45 mph (70 km/h).
- Traffic counts greater than 5,000 vehicles per day.
- Greater than 30 through trains per day.
- Traffic with more than nine (9) school buses per day.
- Substantial number of trucks carrying hazardous materials.
- Continuance of crash history after the installation of flashing lights.
- Intersection that has traffic signals and/or heavy turning movements from a parallel highway onto the tracks within 200 feet (60 m) measured from the edge of the travel way.

---

**Illinois DOT. “Chapter Seven Railroad Coordination.” *Bureau of Design and Environment Manual – 2010 Edition*.**

---

4. Gates and Flashing Signals. Provide flashing signals and gates where one or more of the following conditions are met:

- multiple mainline railroad tracks;
- multiple tracks at or in the vicinity of the crossing which may be occupied by a train or locomotive, so as to obscure from view the movement of another train approaching the crossing;
- high-speed train operation combined with limited sight distance at either single or multiple track crossings;
- a combination of high speeds and moderately high volumes of highway and railroad traffic;
- either a high volume of vehicular traffic, high number of train movements, substantial numbers of school buses or trucks carrying hazardous materials, unusually restricted sight distance, continuing crash occurrences, or any combination of these conditions;
- the expected crash frequency for flashing lights exceeds 0.02 and the benefit-cost ratio equals or exceeds 1.0 (the method for determining the benefit-cost ratio is shown in Figure 7-3.B); and/or

- a diagnostic team recommends them.

In individual cases where a diagnostic team justifies that gates are not appropriate, gates will not be required.

## OTHER CRITERIA STATEMENTS

---

### Germany

---

#### German Train Crossing Regulations

##### Summary

- Definitions
  - Low volume crossing: typically less than 100 vehicles per day
  - Moderate volume crossing: typically 100 to 2,500 vehicles per day
  - High volume crossing: typically more than 2,500 vehicles per day
  - Adequate visibility: A railroad crossing has adequate visibility if the driver of a motor vehicle can view enough of the train route in a distance from the crossing that she can cross the train tracks without danger or stop before them as needed.
  - Private road: Private roads without public traffic and marked as private roads.
- Railroad crossings without grade separations are only allowed on train routes with a speed limit of 160 km/h (99.4 mph).
- Low volume crossings *may* be secured by
  - Adequate visibility.
  - Audible signals from the train, if there is no adequate visibility, and if the train speed limit at the crossing is 20 km/h (12.4 mph) (requires signs on the train route).
  - Audible signals from the train, if there is no adequate visibility, and if the train speed limit at the crossing of field and forest roads is 60 km/h (37.2 mph) (requires signs on the train route).
- Moderate volume crossings of single-track train routes *may* be secured by
  - Adequate visibility and audible signals from the train (requires signs on the train route).
  - Audible signals from the train, if there is no adequate visibility, and if the train speed limit at the crossing is 20 km/h (12.4 mph), with special permit by the regulatory authority (requires signs on the train route).
  - Audible signals from the train, if there is no adequate visibility, and if the train speed limit at the crossing of field and forest roads is 60 km/h (37.2 mph), with special permit by the regulatory authority (requires signs on the train route).



## **1350.04 Traffic Control Systems**

### **(c) Selection of Grade Crossing Warning Devices**

At a minimum:

- All public grade crossings are required to be equipped with Crossbuck signs, a supplemental plaque indicating the presence of multiple tracks (if applicable), and advance warning signs.
- Railroad pavement markings are required at all crossings where active warning devices are present or the posted legal speed limit is 40 mph or higher.

Passive warning devices notify drivers that they are approaching a grade crossing and to be on the lookout for trains. In general, consider stand-alone passive warning devices at grade crossings with low volumes and speeds on both the highway and railway, and where adequate sight distances exist. Active warning devices are to be considered at all other crossings. No national or state warrants have been developed for installation of traffic control devices at grade crossings. Furthermore, due to the large number of significant variables that need to be considered, there is no single system of active traffic control devices universally applicable for grade crossings. Warning systems at grade crossings should be based on an engineering and traffic investigation, including input from the railroad and the WUTC. Primary factors to consider in selecting warning devices are train and highway volumes and speeds; highway and railway geometry; pedestrian volume; accident history; and available sight distance.

---

## Extraction of Accident Prediction Models and Indices

---

This section demonstrates the accident prediction models or indices found in the literature review.

### Mississippi Formula:

$$H.I. = \frac{\frac{SDR}{8} + A5}{2}$$

where H.I. = Hazard Index

SDR = Sight Distance Rating

A5 = Expected number of accidents in five years

### The Ohio Method:

$$H.I. = A_f + B_f + G_f + L_f + N_f + SDR$$

where H.I. = Hazard Index

A<sub>f</sub> = Accident Probability Factor

B<sub>f</sub> = Train Speed Factor

G<sub>f</sub> = Approach Gradient Factor

L<sub>f</sub> = Angle of Crossing Factor

N<sub>f</sub> = Number of Tracks Factor

SDR = Sight Distance Rating

The Wisconsin Method:

$$H.I. = \frac{T\left(\frac{V}{20} + \frac{P^1}{50}\right)}{5} + SDR + Ae$$

where H.I. = Hazard Index

T = Average 24-hour train volume

V = Average 24-hour traffic volume

P<sup>1</sup> = Number of pedestrians in 24 hours

SDR = Sight distance rating

Ae = Accident Experience

North Dakota Rating System:

$$H.I. = (N_f + L_f) + (P_f + D_f + G_f + X_f) + (VT_f) + SDR$$

where H.I. = Hazard Index

N<sub>f</sub> = Number of tracks factor

L<sub>f</sub> = Angle of crossing factor

P<sub>f</sub> = Protection factor

D<sub>f</sub> = Alignment of track and highway factor

G<sub>f</sub> = Approach gradient factor

X<sub>f</sub> = Condition of crossing factor

V = Average 24-hour traffic volume

T<sub>f</sub> = Train volume factor

SDR = Sight distance rating

City of Detroit Formula:

$$\text{H.I.} = \frac{V}{1000} \left( \frac{P}{10} + \frac{F}{20} + \frac{S}{30} \right) + \text{SDR} + N_f + X_f + R_f (100\% - \%P_f) + 2 A_e$$

where H.I. = Hazard Index

V = Average 24-hour traffic volume

P = Number of passenger trains in 24 hours

F = Number of freight trains in 24 hours

S = Number of switch trains in 24 hours

SDR = Sight distance rating

$N_f$  = Number of tracks factor

$X_f$  = Condition of crossing factor

$R_f$  = Road approach factor

$P_f$  = Protection factor

### PEABODY DIMMICK FORMULA<sup>3</sup>

One of the earliest highway-rail crossing accident prediction models is the Peabody Dimmick Formula, also referred to as the Bureau of Public Roads Formula. The Peabody Dimmick Formula, developed in 1941, was the primary formula utilized through the 1950's for resource allocation relating to highway-rail crossings. The specific relationship is as follows:

$$A_5 = 1.28 \frac{(V^{0.170} T^{0.151})}{P^{0.171}} + K \quad (1)$$

where

$A_5$  = expected number of accidents in 5 years

$V$  = average annual daily traffic (AADT)

$T$  = average daily train traffic

$P$  = protection coefficient indicative of warning devices present

$K$  = additional parameter (FHWA, 1986).

The Peabody Dimmick Formula was developed using accident data from rural highway-rail crossings in 29 states. Non-representative sampling of highway-rail crossings (i.e., only rural crossings) hinders the equation's validity for widespread application. Also, advances in both warning device technology and crossing design features quickly surpassed the predefined protection coefficients that were reflective of 1941 conditions.

### NEW HAMPSHIRE INDEX

The next evolutionary step in highway-rail crossing accident prediction methods was the New Hampshire Index which sought to overcome many of the shortcomings of the Peabody Dimmick Formula. The New Hampshire Index has the following basic formulation:

$$HI = (V)(T)(P_f) \quad (2)$$

where

$HI$  = hazard index

$V$  = average annual daily traffic (AADT)

$T$  = average daily train traffic

$P_f$  = protection factor indicative of warning devices present (FHWA, 1986).

---

<sup>3</sup> From Austin and Carson, 2002

Note both the similarity in variables used to predict highway-rail crossing accidents as compared to the Peabody Dimmick Formula and the simplified multiplicative form of the New Hampshire Index.

As stated, this is the *basic* formulation of the New Hampshire Index. Several states have significantly modified this basic formula to allow for inclusion of other accident causative factors. Common variations of the New Hampshire Index follow:

$$HI = (V)(2T_f)(T_s) \frac{(SD + AN + NTR)}{4} \quad (3)$$

$$HI = \frac{(V)(T)(A_5)}{P_f} \quad (4)$$

$$HI = (V)(T) \frac{(TT + TTR + SD + AN + AL + L + G + VSD + W + LI)}{100} \quad (5)$$

$$HI = \frac{(P_f)(V_f)(T)(TS)(NTR)}{160} + (70A_a)^2 + 1.2(SD) \quad A_a = \left( V + \frac{SBP}{1.2} \right) (HM) \quad (6)$$

$$HI = 0.1(P_f)(A_f)(T_f) + (AN)(NTR)(S)(0.5L) + TS \left( (FC)(P) + \left( \frac{(V)(T)}{10,000} \right) + SB \right) \quad (7)$$

$$HI = \frac{(V_f)(P_f)(T)}{(TR + TN + T_f + HS + G + SD + AN)} \quad (8)$$

$$HI = 0.1(V)(T) + 0.1(HS)(TS) + (SD)(AN)(TR)(NTR)(AL) + (A_a^2 + 1)(RF)(LP)(P_f) + (SB)(SBP) + 10(HM) \quad (9)$$

$$HI = \frac{(T)\sqrt{(V)}}{P_f} \quad (10)$$

where

A<sub>5</sub> = number of accidents in five years

A<sub>a</sub> = number of accidents per year

A<sub>f</sub> = accident factor

AL = highway alignment factor

AN = approach angle factor

FC = functional class factor

G = approach grades factor

S = surface type factor

SB = number of school buses

SBP = number of school bus passengers

SD = sight distance factor

T = average number of trains per day

T<sub>f</sub> = number of fast trains

TN = number of night trains factor

HI = hazard index	TR = number and type of tracks factor
HM = hazardous material vehicles factor	TS = train speeds factor
HS = highway speed factor	T <sub>s</sub> = number of slow trains
L = number of lanes factor	TT = type of train movements factor
LI = local interference factor	TTR = type of tracks factor
LP = local priority factor	V = annual average daily traffic
NTR = number of tracks factor	V <sub>f</sub> = annual average daily traffic factor
P = population factor	VSD = vertical sight distance factor
P <sub>f</sub> = protection factor	W = crossing width factor (FHWA, 1986).
RF = rideability factor	

In addition to formula variation, notable differences in the protection factor, P<sub>f</sub>, values exist from state to state. While the protection factor values for wigwags (P<sub>f</sub> = 0.67), traffic signal preemption (P<sub>f</sub> = 0.50) and crossbucks (P<sub>f</sub> = 1.00) are consistent from state to state, different assumed protection factor values for automatic gates (P<sub>f</sub> = 0.10 or 0.13) and flashing lights (P<sub>f</sub> = 0.20, 0.33 or 0.60) can lead to important differences in predicted highway-rail crossing accident frequencies. This variation in protection factor values, combined with the striking dissimilarity between New Hampshire Index formula variations from state to state, raises concerns over its validity in accurately predicting highway-rail crossing accident frequencies.

### NCHRP HAZARD INDEX

Following the development of the New Hampshire Index, a joint effort between the American Association of State Highway Officials (AASHO now AASHTO) and the Association of American Railroads (AAR) was undertaken in response to the disproportionately high number of accidents occurring at highway-rail crossings. The National Cooperative Highway Research Program (NCHRP) Hazard Index, documented in NCHRP Report 50, was developed in 1964 using a five-year span of highway-rail crossing accident data collected from the Interstate Commerce Commission, state agencies and others. The NCHRP Hazard Index closely resembles the basic formulation of the New Hampshire Index described above:

$$EA = (A)(B)(CTD) \quad (11)$$

where

EA = expected accident frequency

A = vehicles per day factor (provided in tabular format as a function of vehicles per day)

B = protection factor indicative of warning devices present

CTD = current trains per day (Schoppert and Hoyt, 1968).

One distinguishing characteristic of the NCHRP Hazard Index is in its treatment of the protection factor, B. For crossbucks, flashing lights and gates, two different protection factor values are defined for urban and rural environments. In some cases, such as the protection factor values for flashing lights, the differences between urban and rural designations can be significant, ranging from B = 0.23 for urban environments to B = 0.93 for rural environments. Because no formal definition of *urban* and *rural* accompanies this formula and the determination of environment type and consequent protection factor value is left to user interpretation, inconsistencies in the highway-rail crossing accident prediction process may exist. This may ultimately lead to erroneous prioritization of highway-rail crossing improvements.

### USDOT ACCIDENT PREDICTION FORMULA

The highway-rail crossing accident prediction methods discussed thus far each have unique shortcomings but in general are concise and easy to apply comprising typically three explanatory variables: highway traffic, train traffic and existing crossing protection (i.e., warning devices). While the simplicity of these models is attractive, the accuracy, consistency and descriptive capabilities are questionable.

The U.S. Department of Transportation's (USDOT) Accident Prediction Formula, developed in the early 1980's, sought to address earlier model limitations. This complex and comprehensive formula comprises three primary equations:

$$a = (K)(EI)(DT)(MS)(MT)(HP)(HL)(HT) \quad (12)$$

$$B = \frac{T_o}{T_o + T}(a) + \frac{T}{T_o + T}\left(\frac{N}{T}\right) \quad (13)$$

$$\begin{aligned} A &= \{0.7159B\} && \text{For Passive Devices} \\ A &= \{0.5292B\} && \text{For Flashing Lights} \\ A &= \{0.4921B\} && \text{For Gates (FRA, 1987; FRA, 1999).} \end{aligned} \quad (14)$$

Each of the multiplicative factors in Equation (12) represents crossing characteristics maintained in the Federal Railroad Administration's Office of Safety highway-rail crossing inventory. These factors were found to be statistically significant in the prediction of accidents at highway-rail crossings using nonlinear multiple regression. The numeric value of each of these factors is calculated using the relationships given in Table 1. Note that some important characteristics, such as sight distance, are not included in Equation (12); factors such as sight distance are unavailable in FRA's highway-rail crossing inventory.



TABLE 1. Factors for Equation (12) (USDOT Accident Prediction Formula)

Factor	Description	Coefficient or Relationship		
		Passive Control	Flashing Lights	Gates
K	Formula Constant	0.002268	0.003646	0.001088
EI	Exposure Index Factor	$((ct+0.2)/0.2)^{0.3334}$	$((ct+0.2)/0.2)^{0.2953}$	$((ct+0.2)/0.2)^{0.3116}$
DT	Day Through Trains Factor	$((d + 0.2)/0.2)^{0.1336}$	$((d + 0.2)/0.2)^{0.0470}$	1.0
MS	Maximum Speed Factor	$e^{0.0077ms}$	1.0	1.0
MT	Main Tracks Factor	$e^{0.2094mt}$	$e^{0.1088mt}$	$e^{0.2912mt}$
HP	Highway Paved Factor	$e^{-0.6160(hp-1)}$	1.0	1.0
HL	Highway Lanes Factor	1.0	$e^{0.1380(h1-1)}$	$e^{0.1036(h1-1)}$
HT	Highway Type Factor	$e^{-0.1000(ht-1)}$	1.0	1.0

c = number of highway vehicles per day  
 t = number of trains per day  
 mt = number of main tracks  
 d = number of through trains per day during daylight  
 hp = highway paved (yes = 1 and no = 2.0)  
 ms = maximum timetable speed in mph  
 h1 = number of highway lanes  
 ht = highway type factor (defined as urban and rural, 1= interstate,... 6 = local) (Schoppert and Hoyt, 1968).

Once the accident prediction value,  $a$ , is determined on the basis of the various crossing-specific characteristics, Equation (13) adjusts the *predicted* number of accidents from Equation (12) to reflect the *actual* accident history at the crossing (FRA, 1987). The variable,  $N$ , is the number of observed accidents in  $T$  years at the crossing, and  $T_0$  is the formula-weighting factor defined as:

$$T_0 = \frac{1.0}{(0.05 + a)} \tag{15}$$

Equation (14) introduces a normalizing constant that is multiplied by the adjusted predicted accident value,  $B$ , in Equation (13) (FRA, 1987). In essence, these normalizing constants calibrate the USDOT Accident Prediction Formula every two years by comparing a sample of the most recent year’s predicted accident frequencies to the actual observed accident frequencies occurring over several previous years. “The process of determining the three new *normalizing constants* for 1998 is performed such that the 1997 accident prediction sum of the top 20 percent of the crossings is made to equal the sum of the observed number of accidents that occurred for those same 20 percent of crossings using the accident data for Calendar Years 1992 to 1996 (to predict 1997).” The normalizing coefficients given in Equation (14) reflect conditions in 1998 (FRA, 1999).

While the USDOT Accident Prediction Formula comprehensively addresses explanatory characteristics that may influence a highway-rail crossing's level of safety (i.e., train and traffic volumes, site and surface characteristics, road/rail-side appurtenances, etc.), the complexity of the formula (i.e., the number and functional relationships of the terms in the formula) does not readily provide the magnitude to which each of the characteristics contribute to a crossing's level of safety. Though this shortcoming may be overcome through supplemental analyses, the formula as currently defined makes it difficult to identify or prioritize design or improvement activities that will most effectively address safety-related problems.

Further, the derivation of the normalizing coefficients used in Equation (14) requires some additional dialogue. Figure 1 reports both the most recent normalizing coefficients and normalizing coefficients from previous years. Note in Figure 1 the steady reduction in normalizing coefficients over time, or in other words, the steady decline in accident prediction model accuracy as compared to observed values. For example, consider gated highway-rail crossings. The adjusted accident frequency value, B, predicted by the USDOT Accident Prediction Formula using Equation (13) is reduced by more than half with the normalizing coefficient of 0.4921 to reflect actual observed safety levels. This shortcoming may be remedied by replicating the original Accident Prediction Formula development using more current data. However, the formula complexity remains an issue.

#### **FLORIDA DEPARTMENT OF TRANSPORTATION ACCIDENT PREDICTION MODEL<sup>4</sup>**

The Florida State University developed an accident prediction model for the Florida Department of Transportation. The model was developed using stepwise regression analysis, transformation of data, dummy variables, and transformation of the accident prediction model to its original scale. The resulting model is:

$$1. t_p = -8.075 + .318 \ln S_t + .484 \ln T + .437 \ln A +$$

$$.387 \ln V_V + (.28 - .28 \frac{MASD}{RSSD})^{**} +$$

$$(.33 - 1.23 \frac{MCSD}{RSSD})^* + .15 (\text{no crossbucks})$$

$$1a. y = \exp (.968t_p + 1.109) / 4$$

$$2. t_a = -8.075 + .318 \ln S_t + .166 \ln T + .293 \ln A +$$

$$.387 \ln V_V + (.28 - .28 \frac{MASD}{RSSD}) +$$

$$.225 (L - 2)^{**} - .233 (\text{gates})$$

$$2a. y = \exp (.938t_a + 1.109) / 4$$

---

<sup>4</sup> From USDOT Grade Crossing Handbook, Appendix F

where:

A = vehicles per day or annual average daily traffic

L = number of lanes

ln = logarithm to the base e

MASD = actual minimum stopping sight distance along highway

MCSD = clear sight distance (ability to see approaching train along the highway, recorded for the four quadrants established by the intersection of the railroad tracks and road)

RSSD = required stopping sight distance on wet pavement

St = maximum speed of train

T = yearly average of the number of trains per day

ta = ln of predicted number of accidents in four year period at crossings with active traffic control devices

tp = ln of predicted number of accidents in four year period at crossing with passive traffic control devices

VV = posted vehicle speed limit unless geometrics dictate a lower speed

y = predicted number of accidents per year at crossing

\* This variable is omitted if crossing is flagged or the circulation is less than zero.

\*\* This variable is omitted if sight restriction is due to parallel road.

\*\*\* This variable is omitted when gates are present.

The predicted number of accidents per year,  $y$ , is adjusted for accident history as follows:

$$Y = y\sqrt{H/(y)(P)}$$

where:

Y = accident prediction adjusted for accident history

y = accident prediction based on the regression model

H = number of accidents for six-year history or since year of last improvement

P = number of years of the accident history period

A simple method of rating each crossing from zero to 90 was derived based mathematically on the accident prediction. This method, entitled Safety (Hazard) Index, is used to rank each crossing. A Safety Index of 70 is considered safe (no further improvement necessary). A Safety Index of 60, or one accident every nine years, would be considered marginal. The Safety Index is calculated as follows:

$$R = X(1 - \sqrt{Y})$$

where:

- R = safety index
- Y = adjusted accident prediction value
  - = 90 when less than 10 school buses per day traverse the crossing
  - = 85 when 10 or more school buses per day and active traffic control devices exist without gates
  - = 80 when 10 or more school buses per day and passive traffic control devices exist

## FLORIDA RAIL MANUAL, MARCH 2000

### B.2.4 Final Crash Prediction Equation

The following formula was developed for use in prioritizing highway railroad grade crossing safety improvements using *Part 924, Title 23, United States Code*.

$$t = -9.21 + 1.14 \log_{10}(A(T + 0.5)) + 0.014V + 0.008S - 0.63L$$

And,

$$P = \frac{2e^t}{1 + e^t}$$

Where,

t = A temporary value used to simplify the mathematical expression.

A = Vehicles per day or Average Daily Traffic (ADT).

T = Average number of trains per day.

V = Posted vehicle speed limit (MPH).

Note - geometry may dictate a lower speed.

S = Maximum train speed (MPH).

e = 2.71828182845904523536... (constant)

L = For,

Crossing with active warning devices use L = 1.

Crossing with passive devices or no warning devices use L = 0.

P = Predicted Number Of Crashes Per Year.

The Predicted Number Of Crashes Per Year (P) is adjusted for crash history. Although this introduces a mathematical bias, it is needed to ensure that all possible hazardous situations are investigated. The Crash Prediction Model explains less than half of the crash environment, whereas human failure is almost always involved. Locations experiencing non predicted crashes should receive special investigation.

The phenomenon of regression toward the mean may apply because a crossing that has two (2) to three (3) crashes one year may not have any more until it reaches its Actual Predicted Crash Rate. The Crash History Adjustment Equation always increases (never decreases) the crash predictor. The following adjustment for crash history is only calculated when the crash history is greater than the crash prediction.

$$P' = P \sqrt{\frac{H}{PY}}$$

Where,

P' = Crash prediction adjusted for crash history.

P = Predicted number of crashes per year.

H = Number of crashes for the six (6) year history or since the last warning device upgrade.

Y = Number of years of crash history.

A simple method of rating each highway railroad grade crossing from zero to 90 was derived based mathematically on the crash prediction. This Safety Hazard Index, is used to rank each highway railroad grade crossing. A highway railroad grade crossing with a crash prediction of 0.05 or one crash every 20 years would have a Safety Hazard Index of 70. A Safety Hazard Index of 70 or greater will not be considered for an improvement. A Safety Hazard Index of 60, or one crash every nine years, would be considered marginal.

The Safety Hazard Index is calculated as follows:

$$I = 90 \left( 1 - \sqrt{\frac{P'}{MAXP}} \right) + 5 \log_{10}(B + 1) F$$

Where,

I = Safety Hazard Index.

P' = Crash prediction adjusted for crash history.

MAXP = Maximum value for crash prediction (currently 1.00000).

B = Number of school buses.

F = Warning device factor where,

If the crossing is active, use F = 1.

If the crossing is passive, use F = 2.

**The Coleman-Stewart Model**

The Coleman-Stewart model uses an expression of the form:

$$\text{Log } H = C_0 + C_1 \text{ Log} C + C_2 \text{ Log} T + C_3 (\text{Log } T)^2 \quad (2.3)$$

Where:  $C$  = vehicle movements per day

$T$  = train movements per day

$H$  = the average number of collisions per crossing per year

A series of collision frequency expressions were developed by Coleman-Stewart for different track classes (number of tracks and region) and warning devices (gates, flashing lights and signs). The results are summarized in Table 2-1.

**Table 2-1 Coefficients of Coleman-Stewart model**

Category		$C_0$	$C_1$	$C_2$	$C_3$
<b>Single-track, Urban</b>	Automatic Gates	-2.17	0.16	0.96	-0.35
	Flashing Lights	-2.85	0.37	0.16	-0.42
	Crossbucks	-2.38	0.26	0.78	-0.18
<b>Single-track, Rural</b>	Automatic Gates	-1.42	0.08	-0.15	-0.25
	Flashing Lights	-3.56	0.62	0.92	-0.38
	Crossbucks	-2.77	0.4	0.89	-0.29
<b>Multiple-track, Urban</b>	Automatic Gates	-2.58	0.23	1.3	-0.42
	Flashing Lights	-2.5	0.36	0.68	-0.09
	Crossbucks	-2.49	0.32	0.63	-0.02
<b>Multiple-track, Rural</b>	Automatic Gates	-1.63	0.22	-0.17	0.05
	Flashing Lights	-2.75	0.38	1.02	-0.36
	Crossbucks	-2.39	0.46	-0.5	0.53

## APPENDIX 2: DATA COMPARISONS

**Table A2—1 Comparison between TxRAIL Tables *GxForm* and *T\_AnnualStateList\_2010***

Variable	Mismatches	Missing values updated or most recent value used
AADT	6	28 (most recent)
MainTrack	4	
OtherTrack	6	
TotalTrn	8	
TotalSwt	5	
MinSpeed	9	
StateHwy	283	
Reason	442	
TypeCrossing	154	
Cantilevers	3	
Gates	16	
FlashOver	5	
FlashMast	26	
Crossbuck	26	
Bells	16	



**Table A2—2 Comparison between TxRAIL *GxForm* Table and FRA Data (2010)**

<b>Variable</b>	<b>Mismatches</b>	<b>Missing values updated or most recent value used</b>
AADT	329	306 (most recent)
TotalTrn		3
SchoolBus	2975	
PrivateCat	836	520
PrivateInd	1154	612
StandStop	2401	10
WDCode	8302	9
AdvWarnSgn	3292	362
OtherStop	97	
OtherSign1	735	315
OtherSign2	285	315
PaveMarks	5876	4
Preemption	4228	
Humpsign	6	485
Four_quad	89	
CrossBuck	9111	1
Gates	1534	
FlashPair	5057	11
Channel	400	1

**Table A2—3 Comparisons between TxRAIL *tbl*CONTROLS Table and TRACI (2010)**

<b>Variable</b>	<b>Mismatches</b>	<b>Missing values updated</b>	<b>Variable</b>	<b>Mismatches</b>	<b>Missing values updated</b>
AdvFlash1	9	149	AdvFlash2	8	148
AdvWarnSgn1	1423		AdvWarnSgn2	1423	2
Bells1	212		Bells2	207	
Cantilevers1	209		Cantilevers2	220	
Channel1	6	147	Channel2	5	148
CrossBucksL1	110	2	CrossBucksL2	158	1
CrossBucksR1	498		CrossBucksR2	440	1
GateLights1	924	135	GateLights2	908	135
Gates1	233	3	Gates2	237	3
HumpSign1	13	151	HumpSign2	10	150
LED1	456	141	LED2	444	143
Masts1	5099	2	Masts2	4921	3
MedianGates1	17	1	MedianGates2	16	1
Medians1	64	152	Medians2	65	151
OtherSign1L1	12	3	OtherSign1L2	8	3
OtherSign1R1	915	3	OtherSign1R2	884	3
OtherSign2L1	0	3	OtherSign2L2	0	3
OtherSign2R1	36	3	OtherSign2R2	27	3
OtherTAWDL1	0	3	OtherTAWDL2	0	3
OtherTAWDR1	0	3	OtherTAWDR2	1	3
PaveMarks1	981	781	PaveMarks2	261	3015
QuadGates1	1	3	QuadGates2	3	8
Roundals1	1293	3	Roundals2	1265	1
SpecProL1	0	3	SpecProL2	0	3
SpecProR1	0	3	SpecProR2	0	3
StopL1	8	1	StopL2	4	1
StopR1	80	1	StopR2	74	1
WDCode1	2570		WDCode2	2537	
WigWags1	7	3	WigWags2	9	3
YieldL1	0	5	YieldL2	2	1
YieldR1	14	1	YieldR2	16	1

**Table A2—4 Inconsistencies between GxForm and TRACI**

<b>Variable</b>	<b>Mismatches</b>	<b>Missing values updated</b>
SchoolBus	2975	
MainTrack	1403	
MaxTTSpeed	3934	
ActualSD1	1483	1457
ActualSD2	1479	1452
CalcApp1SD	1916	34
CalcApp2SD	1917	34
AppObs1	2183	1
AppObs2	2084	1
StopObs1	48	
StopObs2	26	
SDObstructed	3	
App1Sign	529	1634
App2Sign	470	1634
CalcApp1SignFeet	1911	34
CalcApp2SignFeet	1913	34
CalcAWSpeed1	1370	248
CalcAWSpeed2	1386	248
SpeedLimit	3440	
SpeedLimit2	3393	
DTFeet1	2018	13
DTFeet2	2020	13
ENS1	11384	25
ENS2	11434	25
StateHwy	536	
TypeCrossing	582	
Reason	1104	
PubMaint	23321	25
DipHump	98	5836
Goug	2	17787
Lumens	3	17698
Preemption	372	

## APPENDIX 3 PROJECT WORKSHOP AND SURVEY

Appendix 3 documents this project's Task 3.

### WORKSHOP AGENDA

1:00PM to 2:30PM

Project overview .....	Jose Weissmann, UTSA
Analysis approach.....	Jose Weissmann, UTSA
Workshop objectives.....	Jose Weissmann, UTSA
Priority Indices.....	Steve Venglar and Annie Protopapas, TTI
Group discussion 1: Priority index revision framework .....	All participants

Ten-minute Break

2:40PM to 5:00PM

Tentative sets of warrants .....	Jose Weissmann, UTSA
Project selection methodology.....	Jose Weissmann, UTSA
Group discussion 2: Warrants.....	All participants
Group discussion 3: project selection methodology .....	All participants

### ATTACHMENT: SURVEY QUESTIONNAIRE

Please give us your opinion about the importance of each variable to decisions to upgrade from passive to flashers and from passive to gates. Please add any variables in any rating category. Rate both columns from 0 (not necessary) to 5 (crucial):

- 0 Not necessary
- 1 May consider
- 2 Secondary importance
- 3 Important
- 4 Very important
- 5 Crucial



## **WORKSHOP MINUTES**

### **Discussions and Decisions**

The attachments contain the workshop agenda and a questionnaire about the relative importance of variables to consider for warrants as well as the revised priority index. Questionnaire responses will be tabulated and taken into consideration in the priority index and the warrants.

A copy of the presentation was distributed by email and hardcopies were handed out during the meeting.

Besides giving a project status update to the PMC, the objectives of the workshop were to obtain PMC guidance—

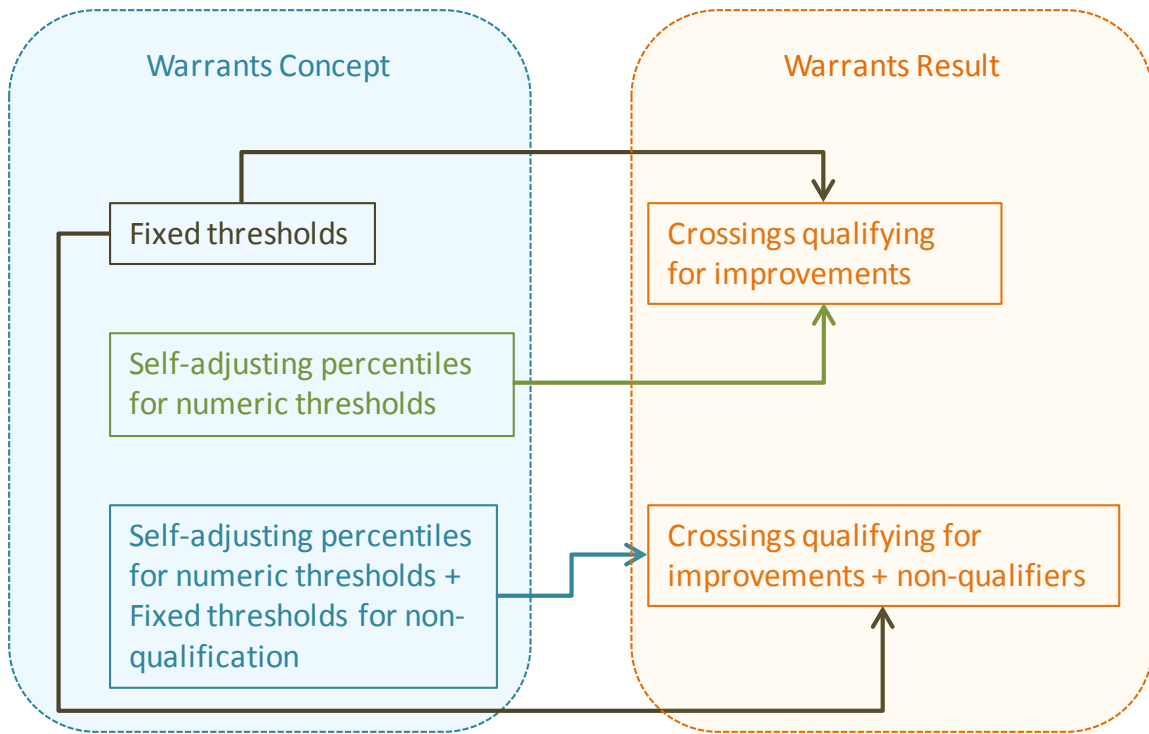
- for the revised Texas Priority Index (TPI) framework,
- to finalize the (currently tentative) warrants for passive crossings, and
- to develop a prioritization methodology integrating active crossings and passive crossings that meet warrants, using the revised TPI and if necessary, additional criteria to ensure a “fair comparison” among passive and active crossings.

### *Warrants*

Warrants based on three different methodologies were presented for discussion, using tentative thresholds based on a combination of literature thresholds and observed variable values occurrences (as percentiles). Warrants are for passive, open, public crossings with at least 2 trains per day.

Participants discussed the advantages and disadvantages of using self-adjusting observed percentiles as thresholds in lieu of fixed numbers in the case of numeric variables such as exposure (AADT and number of trains), crashes, etc.

Using percentiles as thresholds requires a two-step approach: first, use criteria to eliminate crossings from upgrade considerations; then, test the remaining crossing for warrants. This is necessary basically because, in Texas, crossings are upgraded faster than the new ones are built. The elimination criteria would handle situations in which all crossings that qualified for upgrades due to a certain variable (for example, AADT) have already been upgraded and no other crossings attained AADT values that would justify improvements. No matter how low the AADTs in all unprotected crossings became, the threshold percentile always exists. Figure 1 shows a summary of the warrant approaches under consideration by the PMC. Once decisions are made, the researchers will finalize the warrants.



**Figure A3-1 Summary of Warrants' Concepts**

The following PMC decisions regarding warrants are pending:

1. Select overall approach for the warrants (see figure 1).
2. Should the warrants provide just a generic recommendation for active devices, or should they indicate whether or not gates would be advisable in addition to flashers?

Should a "Warrant 1" automatically qualify all crossings with a sight distance obstruction in the stopped condition triangle for improvements? Should it specify gates or only flashers?

*Note:* Mr. Kosmak informed that sight distance data were for the most part uploaded in TRACI between 2004 and 2005. The worst side was checked, obstructions were recorded. Since then, the majority of these crossings have been improved. Nevertheless, the PMC stated that it is important to keep sight distance in this project's analyses and criteria.

3. Should warrants include cost-benefit criteria? If so:
  - a. Include only cost of installation or cost of installation and maintenance?
  - b. The researchers would like to submit the dollar values of costs and benefits to the PMC for approval.

*Texas Priority Index (TPI) Revision and Prioritization Methodology Frameworks*

The prioritization methodology will basically consist of the revised TPI plus criteria to compare *passive crossings meeting warrants* to active crossings with high priorities. Both types of

crossings “compete” for the same source of funds, so the prioritization methodology must provide only one priority list.

Three TPI revision frameworks were proposed during the workshop and are now under consideration by the PMC:

1. A two-step procedure based on the Florida DOT index, which includes cost/ benefit considerations. Step 1: eliminate from consideration crossings that do not meet a certain threshold, and (step 2) prioritize the remaining crossings for improvements using the index. The Florida index would be recalibrated using Texas data and TxRAIL variables only.
2. Recalibrate the Texas Priority Index with more variables, testing alternative equation formats (approach: various statistical modeling methods tested, final method selected and used).

Advantage of 1 and 2: best-fit statistical models correlating TPI variables to risk assessment.

Disadvantages of 1 and 2 (inherent to statistical models): (a) models include calibration errors, and (b) the best fit is no longer guaranteed when data changes.

3. Approach that avoids the disadvantages above: Redevelop the Texas Priority Index using the same procedure develop for TxDOT’s Bridge Division to prioritize bridge maintenance. The new TPI would be the weighted-average of the observed percentiles of each variable considered in a priority index. Each weight reflects the relative importance of the variable. Observed data is used directly, without additional statistical fitting errors.

Advantages and disadvantages depend on the viewpoint in this case, and are:

- a. This method requires a two-step approach analogous to the Florida method, since in Texas crossings are improved faster than new crossings are built. This index should be used in after “non-qualification” criteria eliminate crossings from consideration. Otherwise, some crossings would always theoretically qualify for improvements even in a hypothetical situation in which all crossings in the state are upgraded to the best protection available.
- b. Weights in the proposed weighted average formula represent evaluations of the relative importance of each TPI variable. Weights will be developed based on literature review, results of the attached questionnaire, statistical analyses of TPI variables, and sensitivity analyses of TPI to variable values, using the envelope method to estimate variable ranges observed in the data.

Advantage: the implementation program can treat those weights as default values, allowing the manager to override default weights and emphasize one issue over another if needed (for example, emphasize crossings with school buses in one given year). Disadvantage: some managers dislike overriding default values provided by researchers.

These methodologies are not mutually exclusive. For example, the PMC may decide that the TPI should have approach 1 or 3 but include some of Florida’s concepts as well.

Proposed TPI variable list seemed reasonable to PMC, but it should also include the type of control, and nearby intersection (signalized or not if data available). Variables should be restricted to those already available in the existing database.



## ACTION ITEMS

Issue	PMC	Researchers
General	Respond questionnaire	Tabulate responses and use results in TPI revision and warrants
		Normalize plots of PI variables versus accidents. For plots comparing accidents by day/night trains, estimate night traffic using reduction factors from the literature. Label each bar with the corresponding “y”-value. Separate by active and passive when this clarification is appropriate (example: sight distance is not relevant for protected crossings).
Warrants	Select warrants concept (see fig. 1)	<ol style="list-style-type: none"> <li>1. Develop and test tentative weights for the percentile ranking procedure and submit to the PMC ASAP.</li> <li>2. Finalize warrants</li> </ol>
TPI Revision	Select preferred TPI framework(s)	<ol style="list-style-type: none"> <li>1. Revise TPI</li> <li>2. Include type of control in the TPI variables</li> <li>3. Include only variables available in the database</li> <li>4. Develop a way to flag crossings with missing variables</li> </ol>
Prioritization method	Select underlying concept(s) to rank active crossings and passive crossings meeting warrants	Develop prioritization methodology(ies)

## ADDITIONAL DISCUSSIONS

### Data Availability and Clarification

1. Sight distance
  - a. Data were for the most part uploaded in TRACI between 2004 and 2005. The worst side was checked and obstructions were recorded.
  - b. Most crossings with obstructions have already been either closed or protected. Nevertheless, it is important to keep sight distance in this project’s analysis.
  - c. Recorded obstructions are all inside the Green Book stopped sight distance triangle
  - d. There are two sight distance obstruction variables, one for stopped condition and the other for yield condition. (StopObs1, StopObs2 and AppObs1, AppObs2).
  - e. Consider any obstruction as permanent, even if it is vegetation, which often falls outside railroads’ 250ft jurisdiction and is difficult to maintain.
  - f. Sight distance is not measured for active crossings, but is recorded for approximately 12.5% of them. It is missing for 28% of the passive crossings.
2. Highway speeds. The data records highway speed limits, but at a passive crossing, the actual speeds are significantly lower (usually 30mph). Most county roads limit: 55mph

when not posted.

Variable in the database called Actual stopping distance is used to calculate the advisory speed and to post the reduced speed limit near to the crossing. The research team should work with the speed data that is available.

3. Train speeds. Analogous to highway speeds. Data records maximum timetable (through trains) and minimum (switching trains), but actual speeds of through trains are considerably less than maximum timetable. When evaluating clearances and sight distance-related variables, use timetable (available and conservative).
4. Clearance. Default value of crossing clearance time from stopped condition is assumed as 13 sec for an 18-wheeler to cross one track in the absence of accurate highway and train speed data at the crossing. There are no pre-defined or standardized design vehicles for highway-rail crossings.
5. Crossing angle (30° or less). Consider improvements only for those with more than one accident in the past 5 years.

### **Priority Index /Warrants Variables and Crossing Upgrade Criteria**

#### **Improvements and Signalization: Existing Criteria and Funding**

- a. Active crossings: most improvements are signal preemption in corridors, signal timing and geometry issues.
- b. Signal preemption is a controversial issue under discussion in committees.
- c. There are more collisions in crossings adjacent to highway-highway intersections (both active and passive).
- d. Gated crossings with more than one collision in 5 years are studied.
- e. Most new active crossing upgrades are off-system. Most on-system upgrades are rehabilitation projects.
- f. New MUTCD stop/yield sign requirements: TxDOT installs and the railroads maintain.
- g. On the average, TxDOT spends about 50 million per year to upgrade crossings. At an average cost of \$0.25 million per crossing, TxDOT improves approximately 200 to 250 crossings per year.
- h. Several locations' have geometries that precludes gates.
- i. Important variables to be considered, in addition to what was presented in the slides: Sight distance—Angle of crossing—adjacent traffic signal.

