

TECHNICAL REPORT STANDARD TITLE PAGE

|  |   |  |  |
|--|---|--|--|
| 1. Report No.<br><b>TX-92/990-4F</b>   | 2. Government Accession No.                                 | 3. Recipient's Catalog No.   |  |
| 4. Title and Subtitle<br><b>DEVELOPMENT OF A LOW-PROFILE PORTABLE CONCRETE BARRIER</b>   |   | 5. Report Date<br><b>November 1991</b>   | 6. Performing Organization Code                            |
| 7. Author(s)<br><b>Todd R. Guidry and W. Lynn Beason</b>   |   | 8. Performing Organization Report No.<br><b>Research Report 990-4F</b>   |  |
| 9. Performing Organization Name and Address<br><b>Texas Transportation Institute<br/>         The Texas A&amp;M University System<br/>         College Station, Texas 77843-3135</b>   |   | 10. Work Unit No.  | 11. Contract or Grant No.<br><b>Study No. 2-8-90/1-990</b> |
| 12. Sponsoring Agency Name and Address<br><b>Texas Department of Transportation<br/>         Transportation Planning Division<br/>         P. O. Box 5051<br/>         Austin, Texas 78763</b>   |   | 13. Type of Report and Period Covered  |  |
| 14. Sponsoring Agency Code   |   |  |  |
| 15. Supplementary Notes<br><b>Research performed in cooperation with the State of Texas.<br/>         Research Study Title: Development of a Low-Profile Barrier</b>   |   |  |  |
| 16. Abstract<br><br><p>A low-profile portable concrete barrier has been developed for use in low-speed (45 mph [73 km/h] or less) construction zone. The performance of this barrier is demonstrated through the results of two full-scale crash tests. It is recommended for immediate use in appropriate applications.</p> |   |  |  |
| 17. Key Words<br><b>Concrete Median Barrier<br/>         Portable Concrete Barrier<br/>         Construction<br/>         Safety</b>   |   | 18. Distribution Statement<br><b>No restrictions. This document is available to the public through the National Technical Information Service<br/>         5285 Port Royal Road<br/>         Springfield, Virginia 22161</b> |  |
| 19. Security Classif. (of this report)<br><b>Unclassified</b>  | 20. Security Classif. (of this page)<br><b>Unclassified</b> | 21. No. of Pages<br><b>61</b>  | 22. Price  |



DEVELOPMENT OF A LOW-PROFILE PORTABLE CONCRETE BARRIER

by

Todd R. Guidry and W. Lynn Beason

with contributions by

Harold D. Cooner, Mark L. Marek,  
Hayes E. Ross, Don L. Ivey  
and Wanda Campise

Research Report No. 990-4F

Sponsored by  
Texas Department of Transportation

November 1991

Texas Transportation Institute  
The Texas A&M University System  
College Station, Texas 77843



# METRIC (SI\*) CONVERSION FACTORS

## APPROXIMATE CONVERSIONS TO SI UNITS

Symbol When You Know Multiply By To Find Symbol

### LENGTH

|    |        |        |             |    |
|----|--------|--------|-------------|----|
| in | inches | 2.54   | centimetres | cm |
| ft | feet   | 0.3048 | metres      | m  |
| yd | yards  | 0.914  | metres      | m  |
| mi | miles  | 1.61   | kilometres  | km |

### AREA

|                 |               |        |                     |                 |
|-----------------|---------------|--------|---------------------|-----------------|
| in <sup>2</sup> | square inches | 645.2  | centimetres squared | cm <sup>2</sup> |
| ft <sup>2</sup> | square feet   | 0.0929 | metres squared      | m <sup>2</sup>  |
| yd <sup>2</sup> | square yards  | 0.836  | metres squared      | m <sup>2</sup>  |
| mi <sup>2</sup> | square miles  | 2.59   | kilometres squared  | km <sup>2</sup> |
| ac              | acres         | 0.395  | hectares            | ha              |

### MASS (weight)

|    |                      |       |           |    |
|----|----------------------|-------|-----------|----|
| oz | ounces               | 28.35 | grams     | g  |
| lb | pounds               | 0.454 | kilograms | kg |
| T  | short tons (2000 lb) | 0.907 | megagrams | Mg |

### VOLUME

|                 |              |        |              |                |
|-----------------|--------------|--------|--------------|----------------|
| fl oz           | fluid ounces | 29.57  | millilitres  | mL             |
| gal             | gallons      | 3.785  | litres       | L              |
| ft <sup>3</sup> | cubic feet   | 0.0328 | metres cubed | m <sup>3</sup> |
| yd <sup>3</sup> | cubic yards  | 0.0765 | metres cubed | m <sup>3</sup> |

NOTE: Volumes greater than 1000 L shall be shown in m<sup>3</sup>.

### TEMPERATURE (exact)

|    |                        |                            |                     |    |
|----|------------------------|----------------------------|---------------------|----|
| °F | Fahrenheit temperature | 5/9 (after subtracting 32) | Celsius temperature | °C |
|----|------------------------|----------------------------|---------------------|----|

## APPROXIMATE CONVERSIONS TO SI UNITS

Symbol When You Know Multiply By To Find Symbol

### LENGTH

|    |             |       |        |    |
|----|-------------|-------|--------|----|
| mm | millimetres | 0.039 | inches | in |
| m  | metres      | 3.28  | feet   | ft |
| m  | metres      | 1.09  | yards  | yd |
| km | kilometres  | 0.621 | miles  | mi |

### AREA

|                 |                                   |        |               |                 |
|-----------------|-----------------------------------|--------|---------------|-----------------|
| mm <sup>2</sup> | millimetres squared               | 0.0016 | square inches | in <sup>2</sup> |
| m <sup>2</sup>  | metres squared                    | 10.764 | square feet   | ft <sup>2</sup> |
| km <sup>2</sup> | kilometres squared                | 0.39   | square miles  | mi <sup>2</sup> |
| ha              | hectares (10 000 m <sup>2</sup> ) | 2.53   | acres         | ac              |

### MASS (weight)

|    |                      |        |            |    |
|----|----------------------|--------|------------|----|
| g  | grams                | 0.0353 | ounces     | oz |
| kg | kilograms            | 2.205  | pounds     | lb |
| Mg | megagrams (1 000 kg) | 1.103  | short tons | T  |

### VOLUME

|                |              |        |              |                 |
|----------------|--------------|--------|--------------|-----------------|
| mL             | millilitres  | 0.034  | fluid ounces | fl oz           |
| L              | litres       | 0.264  | gallons      | gal             |
| m <sup>3</sup> | metres cubed | 35.315 | cubic feet   | ft <sup>3</sup> |
| m <sup>3</sup> | metres cubed | 1.308  | cubic yards  | yd <sup>3</sup> |

### TEMPERATURE (exact)

|    |                     |                   |                        |    |
|----|---------------------|-------------------|------------------------|----|
| °C | Celsius temperature | 9/5 (then add 32) | Fahrenheit temperature | °F |
|----|---------------------|-------------------|------------------------|----|

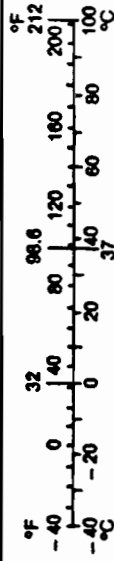

These factors conform to the requirement of FHWA Order 5190.1A.

\* SI is the symbol for the International System of Measurements



## **DISCLAIMER**

The contents of this report reflect the views of the authors who are responsible for the opinions, findings, and conclusions presented herein. The contents do not necessarily reflect the official view or policies of the Texas Department of Transportation (TxDot). This report does not constitute a standard, specification, or regulation and is not intended for construction, bidding or permit purposes. This report was conducted by W. Lynn Beason, P.E., Texas #55905.

## **KEY WORDS**

Concrete Median Barrier, Portable Concrete Barrier, Crash Test(s), Construction, Safety.

## **ACKNOWLEDGEMENTS**

This research study was conducted under the sponsorship of the Texas Department of Transportation. Messrs. Mark Marek, Harold Cooner, and Gary Humes of TxDot worked closely with the researchers. In addition, the efforts of Hayes E. Ross, Jr. and Don L. Ivey made this research possible. Their comments, suggestions, and cooperative spirits were appreciated.

## **DEVELOPMENT OF A LOW-PROFILE CONCRETE MEDIAN BARRIER**

### **ABSTRACT**

A low-profile portable concrete barrier (PCB) has been developed for use in low-speed (45 mph [73 km/h] or less) work zones. The purpose of the low-profile barrier is to shield the work zone and redirect errant vehicles while improving visibility. The low-profile barrier has a total height of only 20 in. (50.8 cm) while most current PCBs have a total height of 32 in. (81.28 cm). The primary advantage of the reduced height of the low-profile PCB is that driver visibility is significantly increased. This enhanced visibility should provide drivers with safer conditions and should reduce the number of accidents. The performance of the barrier is demonstrated through the results of two full-scale crash tests. Based on the results of these crash tests, the low-profile barrier is recommended for immediate use under appropriate conditions.



## TABLE OF CONTENTS

|  | <u>Page</u> |
|--|-------------|
| INTRODUCTION   | 1           |
| DEVELOPMENT OF THE LOW-PROFILE PCB   | 3           |
| FULL-SCALE CRASH TESTS   | 16          |
| RESULTS OF TEST 9901F-1  | 16          |
| RESULTS OF TEST 9901F-2  | 28          |
| CONCLUSIONS  | 37          |
| APPENDIX A. FABRICATION DETAILS  | 39          |
| APPENDIX B. SEQUENTIAL PHOTOGRAPHS OF CRASH TESTS                          | 44          |
| APPENDIX C. ACCELEROMETER TRACES AND PLOTS OF<br>ROLL, PITCH AND YAW RATES | 49          |
| APPENDIX D. TEST VEHICLE PROPERTIES  | 58          |
| REFERENCES   | 61          |



## LIST OF FIGURES

| <u>Figure No.</u> |   | <u>Page</u> |
|-------------------|---|-------------|
| 1                 | GEOMETRY OF SIGHT-DISTANCE PROBLEM                  | 5           |
| 2                 | CATEGORIES OF STUDY                                 | 6           |
| 3                 | LOW-PROFILE PCB CROSS-SECTION                       | 12          |
| 4                 | CONNECTION DETAIL                                   | 13          |
| 5                 | CONNECTION LOADING                                  | 15          |
| 6                 | BARRIER BEFORE TEST 9901F-1                         | 18          |
| 7                 | VEHICLE/BARRIER GEOMETRICS<br>FOR TEST 9901F-1      | 20          |
| 8                 | VEHICLE BEFORE TEST 9901F-1                         | 21          |
| 9                 | BARRIER AFTER TEST 9901F-1                          | 22          |
| 10                | DAMAGE AT JOINTS, TEST 9901F-1                      | 23          |
| 11                | VEHICLE AFTER TEST 9901F-1                          | 25          |
| 12                | DAMAGE TO FRONT AND REAR WHEELS FOR<br>TEST 9901F-1 | 26          |
| 13                | SUMMARY OF RESULTS FOR TEST 9901F-1                 | 27          |
| 14                | BARRIER PRIOR TO TEST 9901F-2                       | 29          |
| 15                | VEHICLE/BARRIER GEOMETRICS<br>FOR TEST 9901F-2      | 30          |
| 16                | VEHICLE BEFORE TEST 9901F-2                         | 31          |
| 17                | BARRIER AFTER TEST 9901F-2                          | 33          |
| 18                | VEHICLE AFTER TEST 9901F-2                          | 34          |

## LIST OF FIGURES (CONTINUED)

| <u>Figure No.</u> |  | <u>Page</u> |
|-------------------|--|-------------|
| 19                | SUMMARY OF RESULTS FOR TEST 9901F-2                  | 36          |
| 20                | LOW-PROFILE CONSTRUCTION DETAILS                     | 40          |
| 21                | SEQUENTIAL PHOTOGRAPHS OF TEST 9901F-1               | 45          |
| 22                | SEQUENTIAL PHOTOGRAPHS OF TEST 9901F-2               | 47          |
| 23                | VEHICLE ANGULAR DISPLACEMENTS FOR<br>TEST 9901F-1    | 50          |
| 24                | LONGITUDINAL ACCELEROMETER TRACE FOR<br>TEST 9901F-1 | 51          |
| 25                | LATERAL ACCELEROMETER TRACE FOR<br>TEST 9901F-1      | 52          |
| 26                | VERTICAL ACCELEROMETER TRACE FOR<br>TEST 9901F-1     | 53          |
| 27                | VEHICLE ANGULAR DISPLACEMENTS FOR<br>TEST 9901F-2    | 54          |
| 28                | LONGITUDINAL ACCELEROMETER TRACE FOR<br>TEST 9901F-2 | 55          |
| 29                | LATERAL ACCELEROMETER TRACE FOR<br>TEST 9901F-2      | 56          |
| 30                | VERTICAL ACCELEROMETER TRACE FOR<br>TEST 9901F-2     | 57          |
| 31                | TEST VEHICLE PROPERTIES (TEST 9901F-1)               | 59          |
| 32                | TEST VEHICLE PROPERTIES (TEST 9901F-2)               | 60          |

## LIST OF TABLES

| <u>Table No.</u> |                               | <u>Page</u> |
|------------------|-------------------------------|-------------|
| 1                | SUMMARY OF CRASH TEST RESULTS | 17          |



## INTRODUCTION

As many cities show continued growth, so do their existing roadway systems. As a result, roadway work zones have become commonplace. The work zones disrupt the continuity of traffic flow and thus introduce a hazard for both motorists and workers. As such, work zones are often protected by longitudinal barriers which are capable of redirecting errant vehicles.

Boundaries of work zones are often defined by the use of reflective barrels or portable concrete barriers (PCBs). These systems work well for vehicles traveling along the major roadway through the work zone. However, if cross-traffic access is required, there are often sight-distance problems. A typical example of this problem would occur where openings in the longitudinal barrier are provided to allow cross-traffic access from parking lots and intersecting roads. The heights of typical longitudinal barriers reduce the cross-traffic driver visibility. This is especially a problem at night, when the barrier obstructs eye contact with oncoming headlights.

In many cases, the cross-traffic vehicle must pull into the mainstream of the roadway before eye-contact is established with the headlights of the oncoming vehicle. This situation has led to many accidents. The objective of this research was to develop a low-profile PCB which is short enough to alleviate the sight-distance problem discussed above, while at the same time maintaining a credible redirective ability. This was accomplished by first studying the geometrics of the situation. Then studies were conducted to establish theoretical barrier performance limits for low-profile barriers

of various heights. This information was integrated into a workable low-profile barrier design which is discussed in this report. The remainder of this report deals with the development, full-scale testing and recommendations for the use of the new low-profile PCB.



## DEVELOPMENT OF THE LOW-PROFILE PCB

The purpose of this research was to develop a low-profile segmented PCB for use in low-speed (45 mph [73 km/h] or less) applications. The design goals for the low-profile PCB were as follows. The low-profile barrier should be short enough so that the barrier does not cause a sight-distance problem for cross traffic. The new low-profile PCB should be capable of redirecting errant vehicles over an appropriate range of vehicle weights, speeds and impact angles. Texas Department of Transportation (TxDot) engineers requested that the maximum lateral deflection of the barrier should be held to a minimum. The remainder of this section addresses these issues.

It was decided that an unobstructed line-of-sight between the cross-traffic drivers eye and the center of the headlight of the oncoming vehicle provides the boundary for acceptable barrier performance. To study the sight-distance problem, it was necessary to define headlight heights and other related geometric constraints as described below.

A random survey of one hundred vehicles was conducted to establish the range of typical headlight heights. In this study, the headlight height was defined as the measured distance between roadway surface and the center of the headlight. The headlight heights varied for different makes and models of vehicles. Of importance, however, is the range that encompassed most of the vehicle headlights heights and the minimum headlight height. Most of today's cars have headlight heights between 24 and 28 in. (61 cm and 71 cm), with the minimum height being 24 in. (61 cm). None of the vehicles measured

had headlight heights less than 24 in. (61 cm). In addition, A POLICY ON GEOMETRIC DESIGN OF HIGHWAYS AND STREETS, 1990 by AASHTO suggests that the minimum allowable headlight height should be 24 in. (61 cm) (1). Therefore, the minimum headlight height of 24 in. (61 cm) was used in the following sight-distance analysis.

In addition to the headlight height, it was necessary to know the eye height of the driver of the cross-traffic vehicle. AASHTO requires a driver's design eye height of 42 in. (107 cm) (1). Hence, this value was used to generate the results discussed here.

There are many other variables which affect the sight-distance problem including the offset of the oncoming vehicle and the offset of the cross-traffic vehicle to the barrier, as shown in Figure 1. Further, the situation depicted in Figure 1 can occur in conjunction with three different geometric conditions as follows.

1. Constant slope - flat terrain
2. Sag curve
3. Crest curve

These geometric conditions are illustrated in Figure 2.

Simplified geometric analyses were conducted for each of these geometric conditions and a wide range of offset conditions. It was found that the cross-traffic drivers sight-distance is unlimited as long as the barrier height is less than 24 in. (61 cm-the minimum headlight height) for both constant slope and sag vertical curves. However, in the case of crest vertical curves it was found that the cross-traffic drivers sight-distance is significantly increased by the use of barrier heights less than 24 in.

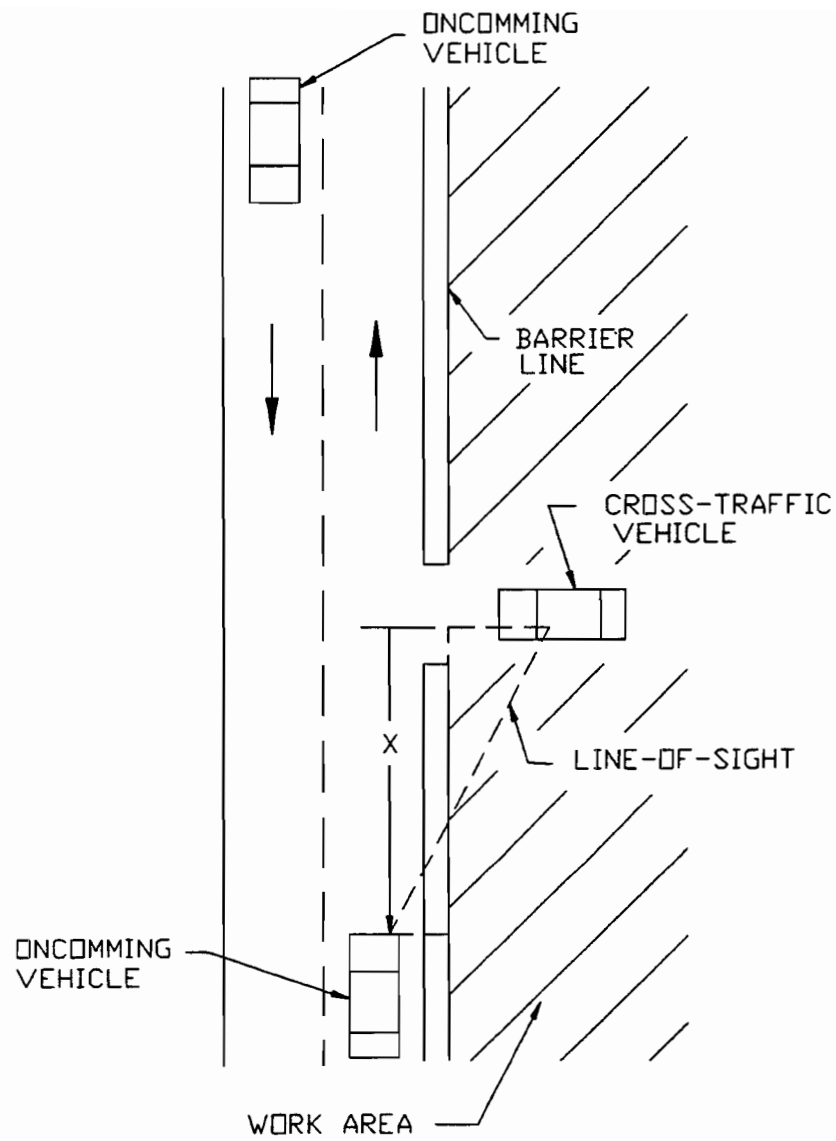

**FIGURE 1 Geometry of sight-distance problem.**

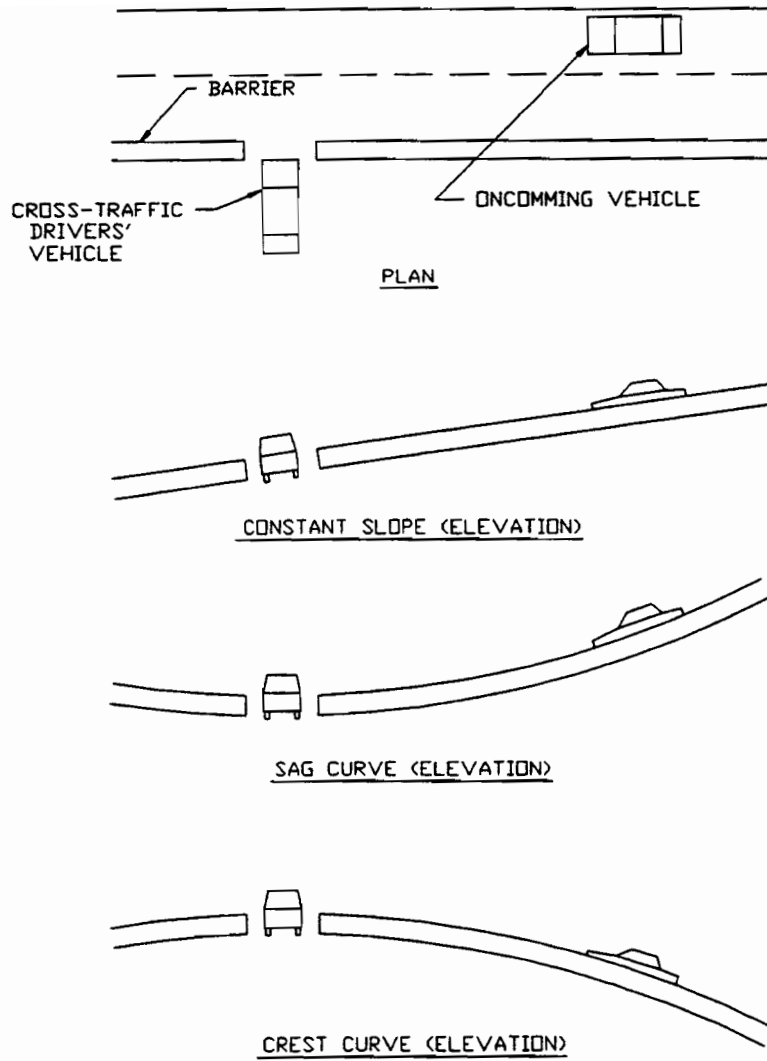

**FIGURE 2 Categories of study.**

(61 cm). The degree of limitation in this latter case depends to a large extent upon the geometric conditions assumed. AASHTO sets limits for crest vertical curve design parameters based upon driver comfort, visibility and stopping sight-distance (1). These limiting parameters result in minimum curve radii for given design speeds. Cross-traffic driver analyses were done for 45 mph (73 km/h) AASHTO requirements. In addition, headlight offsets of 2, 14 and 26 ft (0.61, 4.3 and 7.9 m) were examined to represent one, two and three lanes of oncoming traffic. The AASHTO design stopping sight-distance for a vehicle travelling at 45 mph (73 km/h) is 325 ft (99 m) (1). Results from this analysis show that a barrier height of 20 in. (51 cm) provides sufficient vision of one or both headlights for the above conditions. Therefore, an overall barrier height of 20 in. (51 cm) is acceptable for 45 mph (73 km/h) applications. While the 20 in. (51 cm) barrier meets AASHTO requirements, the cross-traffic driver's visibility is further improved as the barrier height is reduced. Based on this sight-distance analysis it was determined to develop a low-profile barrier that was 20 in. (51 cm) tall or shorter.

The feasibility of the low-profile barrier was first suggested in work by Don L. Ivey and H.E. Ross Jr. which took place in advance of the current contract with TxDot. Early example designs were disclosed to the Texas A&M University System (TAMUS). These early conceptual designs served as a basis for the current design. A patent application was under development before the development of the design of the low-profile was begun. The patent application for the low-profile PCB was filed for TAMUS on April 25, 1991.

The first step in the design process was to define appropriate

collision criteria for the low-profile barrier in cooperation with TxDot engineers. After discussion with TxDot engineers, test conditions were established. Since the low-profile barrier is intended for use in urban work zones where speeds are limited to 45 mph (73 km/h), it was determined that 45 mph (73 km/h) provides a reasonable test speed for all conditions. Because of the potentially hazardous consequences associated with failure to redirect, it was decided to select the remainder of the crash test parameters to reflect relatively severe conditions. Therefore, the strength test was established to be a 3/4 ton pick-up impacting at 45 mph (73 km/h) with an angle of 25 degrees. It is believed that this test represents a very severe set of impact conditions for the proposed application. The stability test was determined to be an 1800 lb (817 kg) small automobile impacting at 45 mph (73 km/h) with an angle of 20 degrees. These angles are consistent with current strength and stability tests for full-service barriers.

After the test criteria were established, the research focused on determining the minimum barrier height that is required to achieve the desired goal.

Preliminary barrier analyses were conducted using computer simulations. The computer program used was HVOSM (Highway-Vehicle-Object-Simulation-Model) (2). The version of HVOSM used in the study was the RD-2 version which incorporates modifications developed by researchers at the Texas Transportation Institute (TTI). The TTI modifications permit the structure of the vehicle to interact with the sloped faces of a multi-faced

rigid barrier. Studies of rigid New Jersey CMBs made with this modified version of HVOSM have been reasonably successful.

A 3/4 ton pick-up computer model was not available at the outset of the project; therefore, a large car model was used in its place for the HVOSM simulations. The simulation results suggested that the minimum acceptable barrier height is 18 in. (46 cm) for the impact criteria discussed above. At 18 in. (46 cm) the large automobile remained stable. At a barrier height of 16 in. (41 cm) the large automobile rolled over the barrier. Since a 3/4 ton pick-up has a higher center of gravity than a large automobile, it was judged that the barrier should be taller than 18 in. (46 cm). Therefore, a barrier height of 20 in. (51 cm) was established based on these results and engineering judgment. The authors believe that a barrier height of 20 in. (51 cm) is close to the minimum acceptable height for this application.

In reviewing previous automobile tests on the New Jersey Concrete Median Barrier (CMB) and the single-slope CMB, it can be seen that the stability of an impacting vehicle is significantly affected by the shape of the barrier face (3,4,5). Both the New Jersey and single-slope CMBs have sloped sides. The sloped sides induce upward acting vertical forces on the impact side of the vehicle. This force, in combination with tire interaction forces, causes the impact side of the vehicle to rise. This vertical rise imparts a roll motion to the vehicle. The severity of the roll motion depends upon the vehicle properties and impact conditions. If the roll motion is severe enough, the vehicle will experience full roll-over.

Results of full-scale crash tests show that the impact side of automobiles, pick-ups, and suburban-type vehicles do not have a tendency to rise if the barrier face is vertical (4). This is the case because the impact forces have no vertical components, and the tire-barrier interaction forces alone are not sufficient to force the impact side of the vehicle to rise. The result is little or no roll motion away from the barrier.

Because of the reduced height of the low-profile barrier, it is important to control the upward vertical displacement of the impact side of the vehicle so that the vehicle does not vault over the barrier. Therefore, a negative slope was cast into the impact surface of the low-profile barrier to help prevent vertical displacement of the impact side of the vehicle. The negative slope significantly changes the tire barrier interaction thus reducing the tendency for the vehicle to rise due to this mechanism. In addition, the unbalanced vertical component of the impact force acts in a downward direction on the vehicle which further restricts the tendency for the impact side of the vehicle to rise. Using engineering judgement and simplified analyses, it was determined that a negative slope of 1 in 20 would provide the desired effect.

To keep the lateral deflections of the barrier to a minimum required an adequate combination of barrier weight and connection moment capacity. The effects of barrier weight and connection moment capacity on the lateral deflections of the low-profile barrier were studied using SABS (6). SABS is a computer simulation program that yields deflections of segmented PCBs based on force versus time data derived from similar crash tests. For this study, deflections were determined for 20, 25 and 30 ft (6.1 m, 7.6 m and



9.1 m) barrier segment lengths. The weight of the barrier was somewhat constrained to be in the 500 to 600 lb/ft (745 to 894 kg/m) range given the geometric constraints discussed previously. For barrier weights in this range, and a 100,000 ft-lb (136,000 N-M) connection moment capacity, the deflections are approximately the same for all three segment lengths. Therefore, no significant advantage is given by using 25 or 30 ft (7.6 or 9.1 m) segments over the 20 ft (6.1 m) segment for this connection moment capacity. In addition, using a shorter segment allows a reduced turning radius while enhancing barrier maneuverability. Based on these results it was concluded that a combination of a barrier weight of approximately 550 lb/ft (745 kg/m) for a 20 ft (6.1 m) segment, and a 100,000 ft-lb (136,000 N-M) moment connection capacity would appropriately limit lateral deflections to less than 6 in. (15.2 cm).

Based on the above discussions, the barrier height was established at 20 in. (51 cm), the minimum barrier weight was set at 550 lb/ft (745 kg/m), and the slope of the barrier face was set at a negative 1:20. The resulting barrier cross-section is shown in Figure 3. The outline of the New Jersey PCB is also presented in Figure 3 for comparison purposes. The low-profile barrier shape yields an actual weight of approximately 560 pounds per linear foot (834 kg/m).

Several different connection schemes were considered for the new low-profile PCB including those previously used on many conventional PCBs. However, none of these existing connection details were appropriate. Therefore, a new connection detail was developed as shown in Figure 4. The connection is accomplished by aligning the ends of two barrier segments and

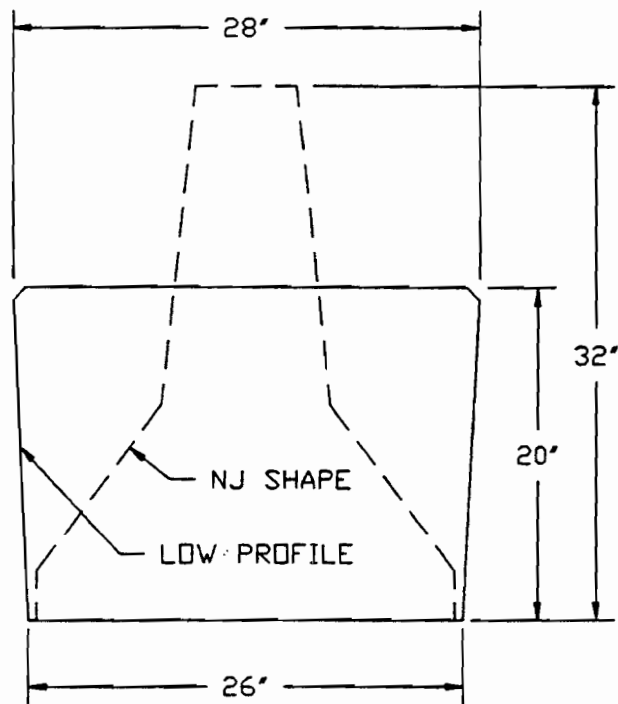

**FIGURE 3 Low-Profile PCB cross-section.**

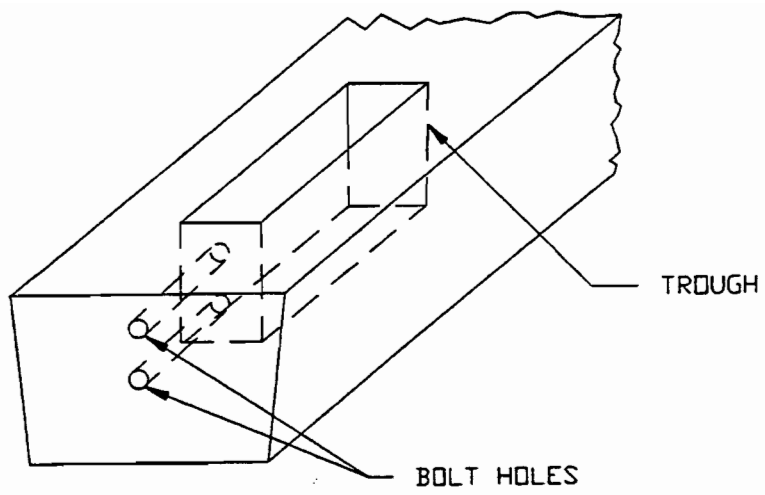
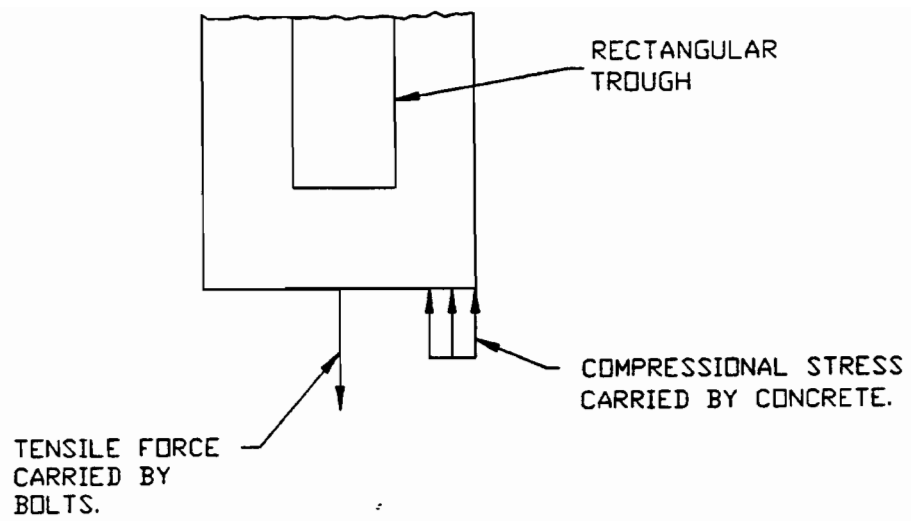

**FIGURE 4 Connection detail.**

inserting two ASTM A36 bolts through the connection holes which are recessed into a rectangular trough which is cast into the end of each segment. This trough allows the bolts to be removed and inserted freely. When the connection is loaded, a moment develops between the tensile force in the bolts and the compressive force in the extreme concrete fibers as shown in Figure 5. This connection results in a moment capacity slightly in excess of 100,000 ft-lbs (136,000 N-M).

The tolerances in the connection holes were set so that the barrier can be assembled on roadways with moderate vertical and horizontal curves. The barrier connection can tolerate angles up to four degrees in both the horizontal and vertical directions. This means that 20 ft (6.1 m) long barrier segments can be used to turn horizontal curves with radii of curvature of 150 ft (46 m).

Complete fabrication details for the new low-profile barrier are presented in Figure 20 in Appendix A.



**FIGURE 5 Connection loading.**



## FULL-SCALE CRASH TESTS

Two full-scale crash tests were conducted on the low-profile PCB to evaluate its performance relative to structural adequacy, occupant risk, and vehicle exit trajectory. The first test involved a 4,500 lb (2,043 kg) 3/4 ton pick-up which impacted the PCB at 45 mph (73 km/h) with an encroachment angle of 25 degrees. The second test involved an 1800 lb (817 kg) compact car which impacted the PCB at 45 mph (73 km/h) with an encroachment angle of 20 degrees.

The tests were conducted using six 20 ft (6.1 m) long low-profile concrete segments connected together to form a 120 ft (36.4 m) longitudinal barrier. The segments were placed on the existing concrete surface at the TTI Proving Ground with no positive attachment to the roadway surface.

In both of the full-scale crash tests, the vehicles impacted the 120 ft (36.4 m) long longitudinal barrier at a point located approximately 5 ft (1.5 m) upstream of the middle barrier segment joint. This impact point was chosen to provide the most critical impact situation with respect to both strength and snagging. Test statistics for the two crash tests are summarized in Table 1. Sequential photographs of the tests are presented in Appendix B. Accelerometer traces and plots of roll, pitch, and yaw are presented in Appendix C.

### Results of Test 9901F-1

In this test, a 1984 GMC Sierra 2500 Pickup was directed into the PCB. Figure 6 presents the barrier prior to impact. The pickup is shown in

TABLE 1 SUMMARY OF CRASH TEST RESULTS

| Test No.                               | 9901F-1              | 9901F-2              |
|--|----------------------|----------------------|
| Vehicle Weight, lb (kg)                | 4500(2043)           | 1800(817)            |
| Impact Speed, mph (km/hr)              | 44.4(71.4)           | 45.7(73.5)           |
| Impact Angle, degrees                  | 26.1                 | 21.3                 |
| Exit Angle, degrees                    | 0.0                  | 7.4                  |
| Displacement, in (cm)                  | 5.0(12.7)            | 0.0(0.0)             |
| Occupant Impact Velocity<br>ft/s (m/s) |                      |                      |
| Longitudinal                           | 21.2(6.5)            | 11.7(3.6)            |
| Lateral                                | 16.0(4.9)            | 18.6(5.7)            |
| Occupant Ridedown Acceleration<br>g's  |                      |                      |
| Longitudinal                           | -6.0                 | -1.1                 |
| Lateral                                | -11.4                | -8.7                 |
| Vehicle Damage Classification          |                      |                      |
| TAD                                    | 11FL1                | 11LD3                |
| CDC                                    | 11FLLK1 &<br>11LDLW1 | 11FLEK2 &<br>11LDEW3 |



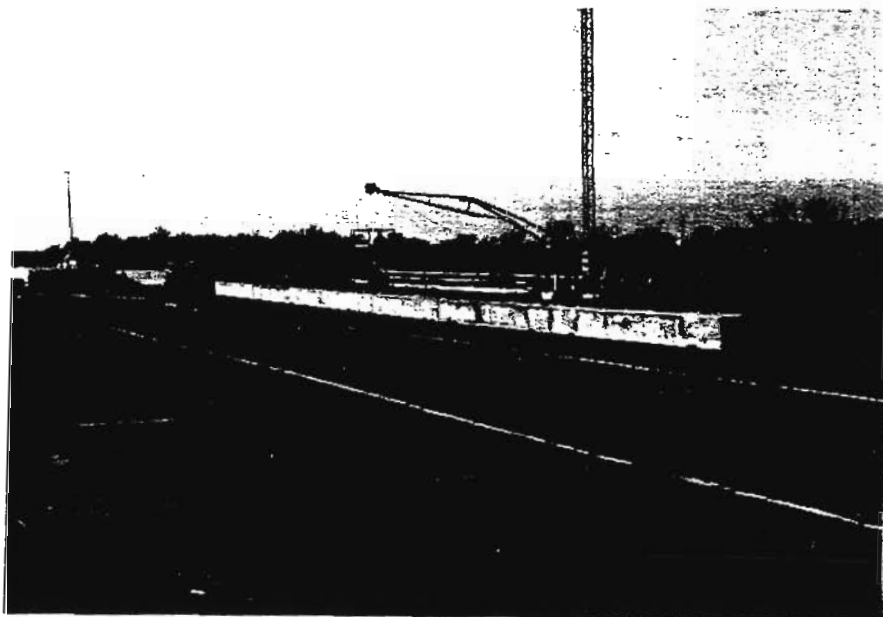

FIGURE 6 Barrier before Test 9901F-1.

Figures 7 and 8. The test inertia weight of the vehicle was 4,500 lb (2,043 kg), and its gross static weight was also 4,500 lb (2,043 kg). The height to the lower edge of the vehicle bumper was 17.5 in. (44.4 cm), and the height to the upper edge was 26.5 in. (67.3 cm). Additional dimensions and information on the vehicle are given in Figure 31 of Appendix D. The vehicle was directed into the barrier using a reverse cable tow and guidance system. The vehicle was free-wheeling and unrestrained just prior to impact.

The vehicle was travelling at a speed of 44.4 mi/h (71.4 km/h) when it impacted the barrier. The impact angle was 26.1 degrees. Immediately after impact, the bumper of the vehicle rode up on top of the barrier. At approximately 23 msec after impact, the left front tire impacted the barrier. The barrier began to move laterally at 66 msec, and the vehicle began to redirect at 71 msec after initial impact. The right front tire became airborne at 117 msec, the left front at 133 msec and the right rear at 217 msec. At approximately 357 msec, the vehicle was travelling parallel to the barrier with a speed of 37.0 mi/h (59.5 km/h), and the rear of the vehicle impacted the barrier shortly thereafter. The vehicle exited the barrier at 768 msec, travelling virtually parallel with the barrier at a speed of 34.8 mi/h (56.0 km/h). Sequential photographs of the test are presented in Figure 21 in Appendix B.

The barrier received some damage as shown in Figures 9 and 10. The maximum lateral movement of the barrier was 5.0 in. (12.7 cm) at the impacted (center) joint. At the impacted connection, vehicle bumper interaction resulted in slight damage to the upper edge of the barrier. One



FIGURE 7 Vehicle/barrier geometrics for Test 9901F-1.

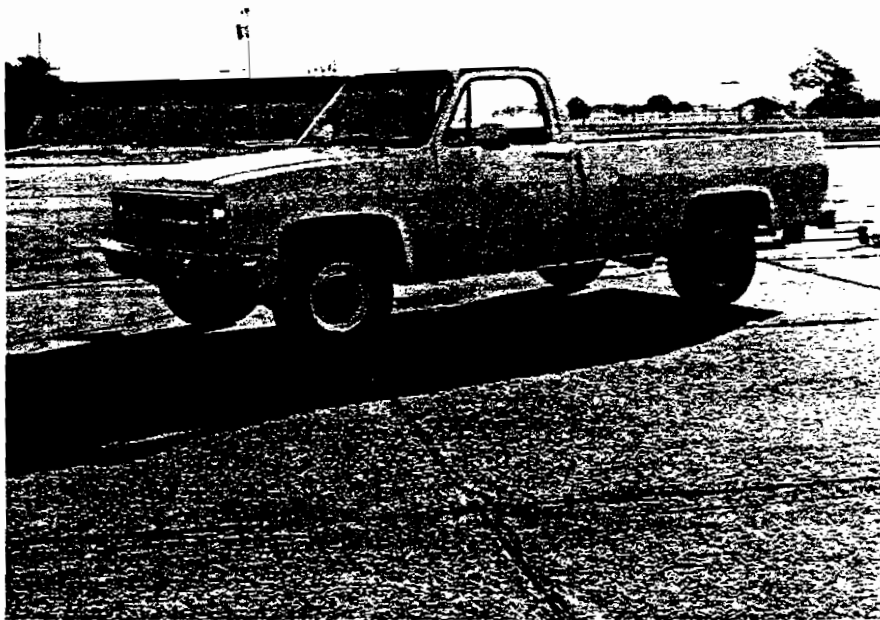

FIGURE 8 Vehicle before Test 9901F-1.

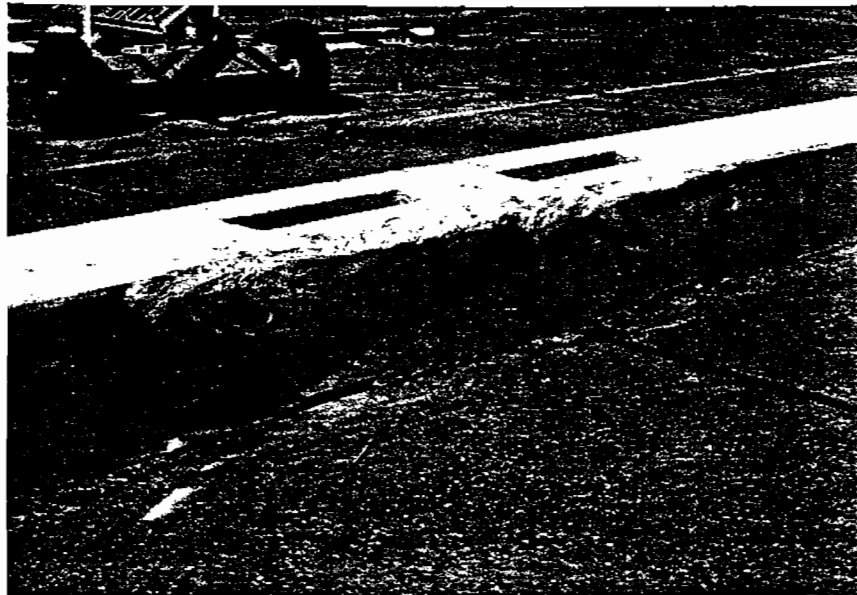
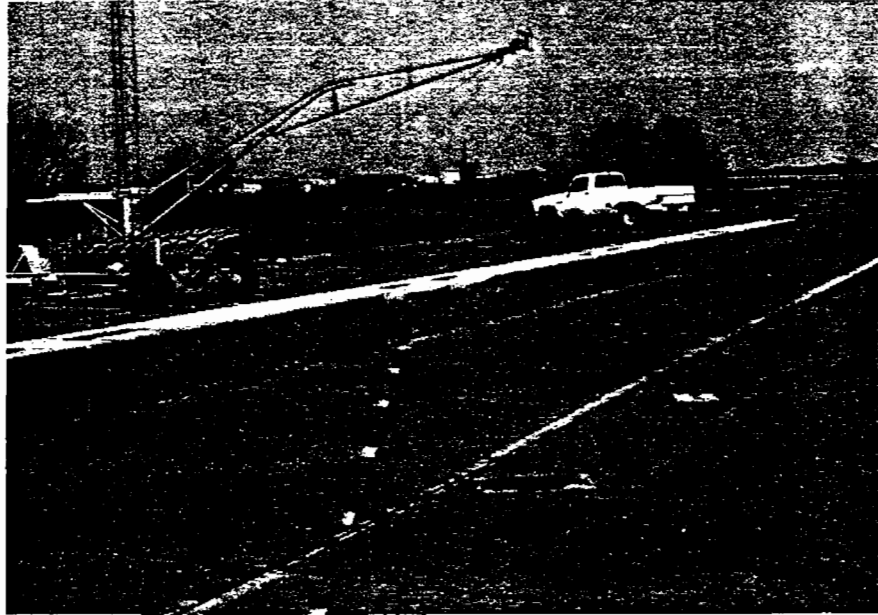

FIGURE 9 Barrier after Test 9901F-1.

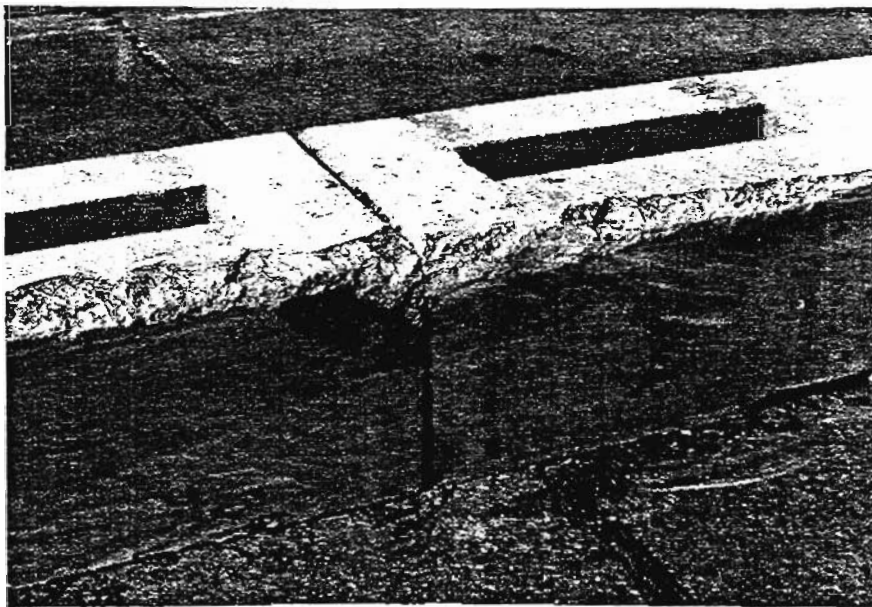
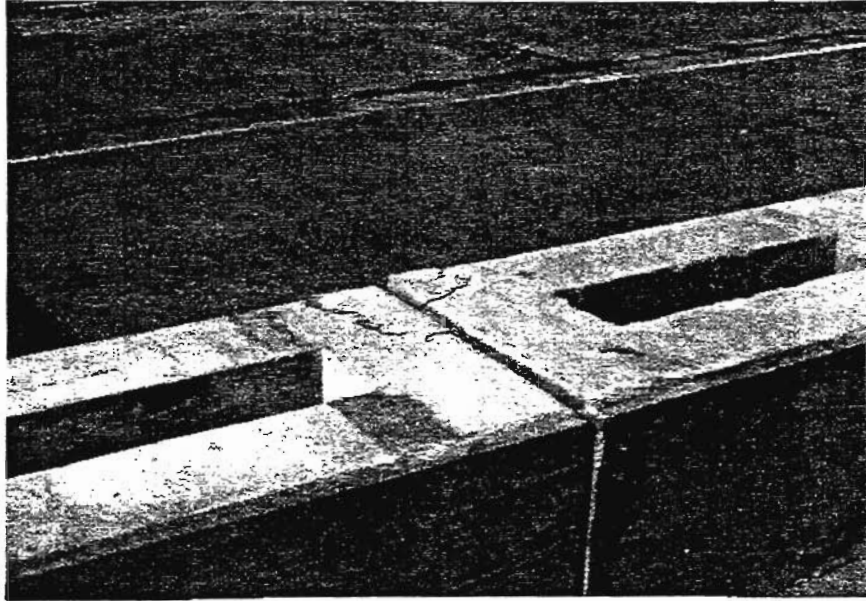

FIGURE 10 Damage at joints, Test 9901F-1.

downstream experienced a shallow delamination. These damages exposed no reinforcing steel and are not considered to be structurally significant.

The vehicle (shown in Figures 11 and 12) sustained minimal damage to the left side; however, the floorpan and frame were bent, and the A-arms were damaged. There was also damage to the front bumper, left front quarter panel, left door, left rear quarter panel, and the rear bumper. The wheelbase on the left side was shortened from 131.5 in. (3.3 m) to 120.75 in. (3.1 m).

Data from the electronic instrumentation were digitized for evaluation and post-test processing. As stated previously, the impact speed was 44.4 mph (73 km/h), and the angle of impact was 26.1 degrees. NCHRP 230 describes occupant risk evaluation criteria, and it places limits on these for acceptable performance for tests conducted with 1,800 lb (817 kg) vehicles (7). These limits do not apply to the tests conducted with 4,500 lb (2,043 kg) vehicles but were computed for information only. The occupant impact velocity was 21.2 ft/s (6.5 m/s) in the longitudinal direction and 16.0 ft/s (4.9 m/s) in the lateral direction. The highest 0.010 sec average occupant ridedown accelerations were -6.0 g (longitudinal) -11.4 g (lateral). These and other pertinent data from this test are presented in Figure 13. Vehicular angular displacements are displayed in Figure 23 in Appendix C. Vehicular accelerations versus time traces filtered at 300 Hz are presented in Figures 24 through 26 in Appendix C. These data were further analyzed to obtain the 0.050 second average vehicle accelerations. The maximum 0.050 second average accelerations measured near the center-of-gravity of the vehicle were -5.6 g (longitudinal) and -7.7 g (lateral).



FIGURE 11 Vehicle after Test 9901F-1.



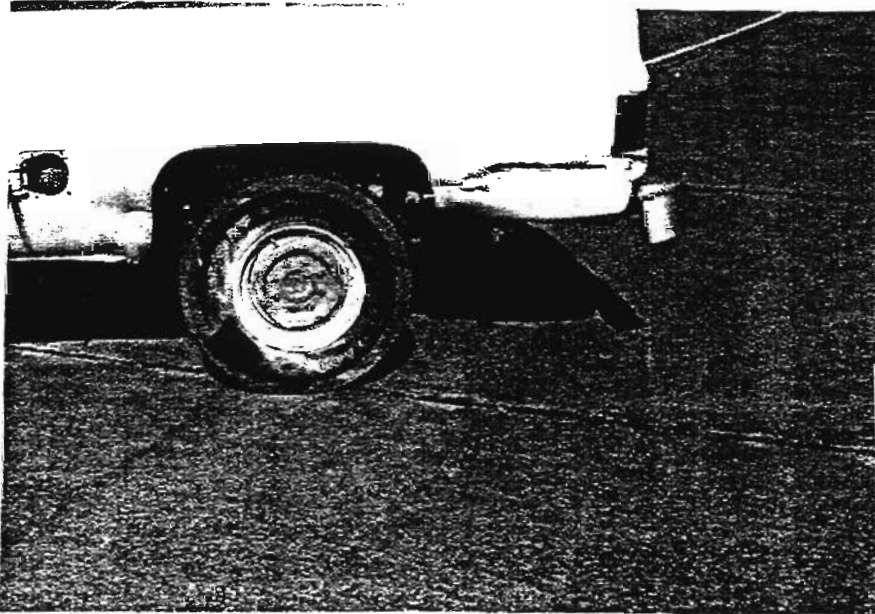
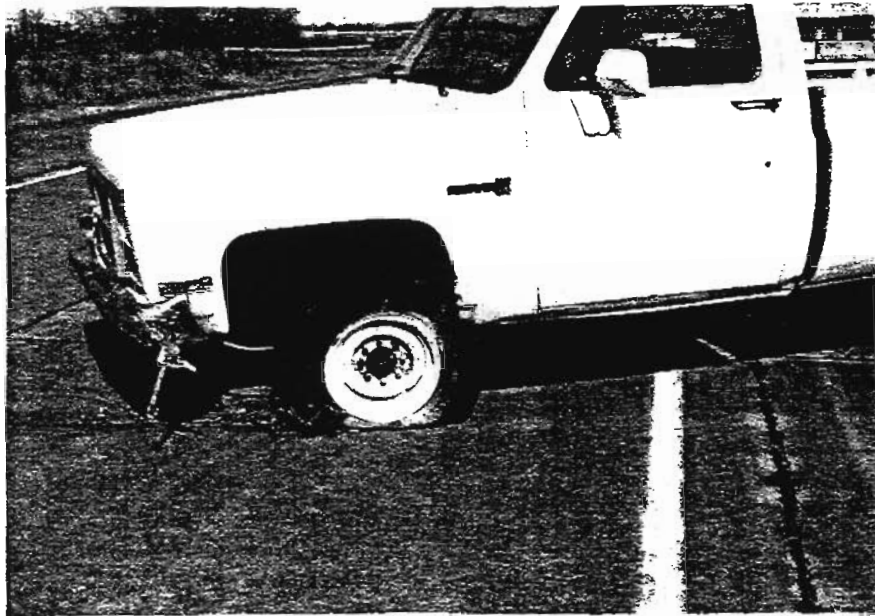

FIGURE 12 Damage to front and rear wheels for Test 9901F-1.



Test No . . . . . 9901F-1  
 Date . . . . . 01/17/91  
 Test Installation . . . . . Low Profile Barrier  
 Installation Length . . . . . 120 ft (37 m)  
 Maximum movement . . . . . 5 in. (12.7 cm)  
 Vehicle . . . . . 1984 GMC Pickup  
 Vehicle Weight . . . . . 4,500 lb (2,043 kg)  
 Test Inertia . . . . . 4,500 lb (2,043 kg)  
 Gross Static . . . . . 4,500 lb (2,043 kg)  
 Vehicle Damage Classification  
 TAD . . . . . 11FL1  
 CDC . . . . . 11FLK1 & 11LDLW1  
 Maximum Vehicle Crush . . . . . 3.0 in. (7.6 cm)

Impact Speed . . . . . 44.4 mi/h (71.4 km/h)  
 Impact Angle . . . . . 26.1 degrees  
 Speed at Parallel . . . . . 37.0 mi/h (59.5 km/h)  
 Exit Speed . . . . . 34.8 mi/h (56.0 km/h)  
 Exit Trajectory . . . . . 0 degrees  
 Vehicle Accelerations  
 (Max. 0.050-sec Avg)  
 Longitudinal . . . . . -5.6 g  
 Lateral . . . . . -7.7 g  
 Occupant Impact Velocity  
 Longitudinal . . . . . 21.2 ft/s (6.5 m/s)  
 Lateral . . . . . 16.0 ft/s (4.0 m/s)  
 Occupant Ridedown Accelerations  
 Longitudinal . . . . . -6.0 g  
 Lateral . . . . . -11.4 g

FIGURE 13. Summary of results for Test 9901F-1.

After impact, the vehicle redirected and did not penetrate, vault or roll over the barrier. The barrier moved laterally 5 in (12.7 cm). There were no detached elements or debris to show potential for penetration of the occupant compartment or to present undue hazard to other traffic. The vehicle remained upright and stable during the impact with the barrier and after exiting the test installation. The vehicle trajectory at loss of contact indicates minimum intrusion into the adjacent traffic lanes.

#### **Results of Test 9901F-2**

In this test a 1981 Honda Civic was directed into the low-profile PCB deployed in a temporary configuration. The barrier configuration prior to this test is shown in Figure 14 for Test 9901F-1. Figures 15 and 16 presents the vehicle prior to the impact. The test inertia weight of the vehicle was 1,800 lb (817 kg), and its gross static weight was 1,965 lb (892 kg). The height to the lower edge of the vehicle bumper was 14.0 in. (35.6 cm), and the height to the upper edge was 19.5 in. (49.5 cm). Additional dimensions and information on the vehicle are given in Figure 32. The vehicle was directed into the barrier using a cable reverse tow and guidance system. The vehicle was free-wheeling and unrestrained just prior to impact.

The vehicle was travelling at a speed of 45.7 mi/h (73.5 km/h) when it impacted the barrier. The impact angle was 21.3 degrees. At approximately 27 msec after impact, the left front tire impacted the barrier, and at 40 msec the vehicle began to redirect. The right side of the vehicle began to lift at 125 msec. At approximately 174 msec, the

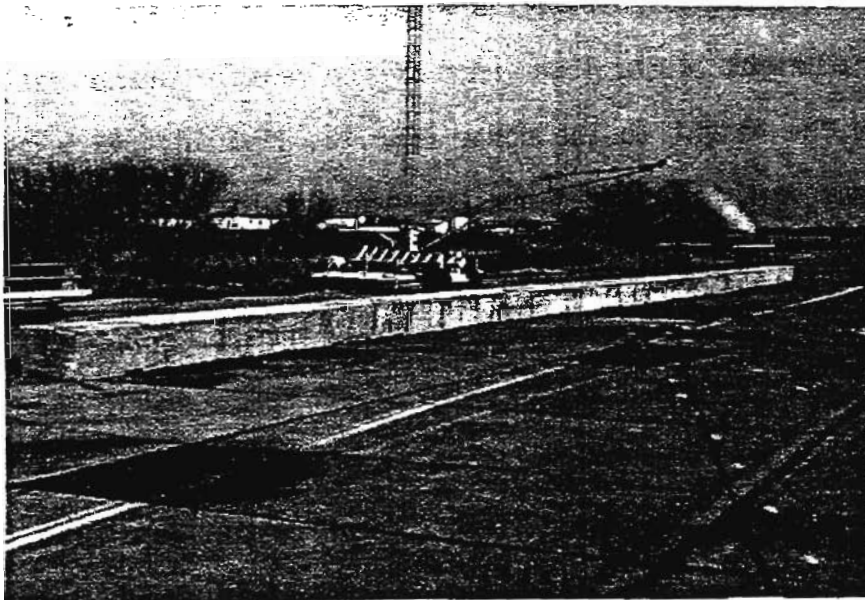
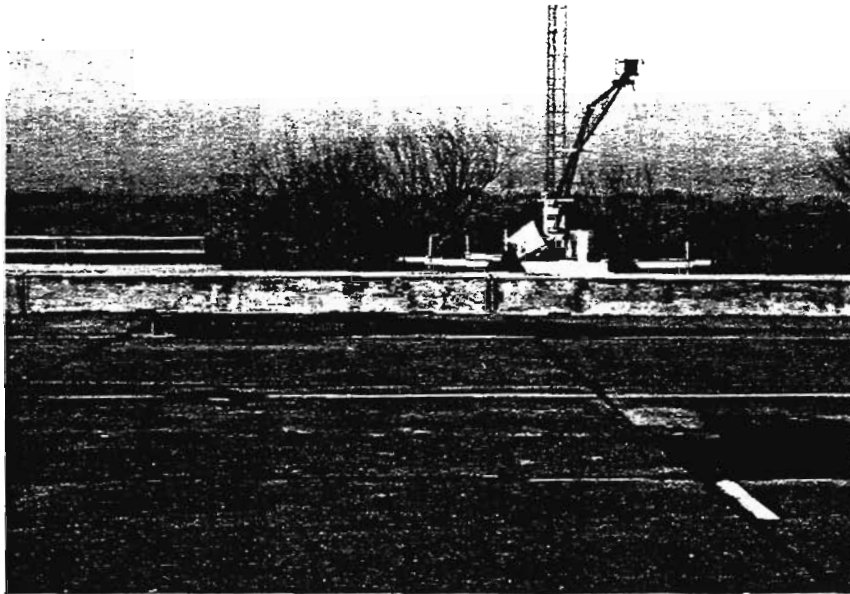

FIGURE 14 Barrier prior to Test 9901F-2.

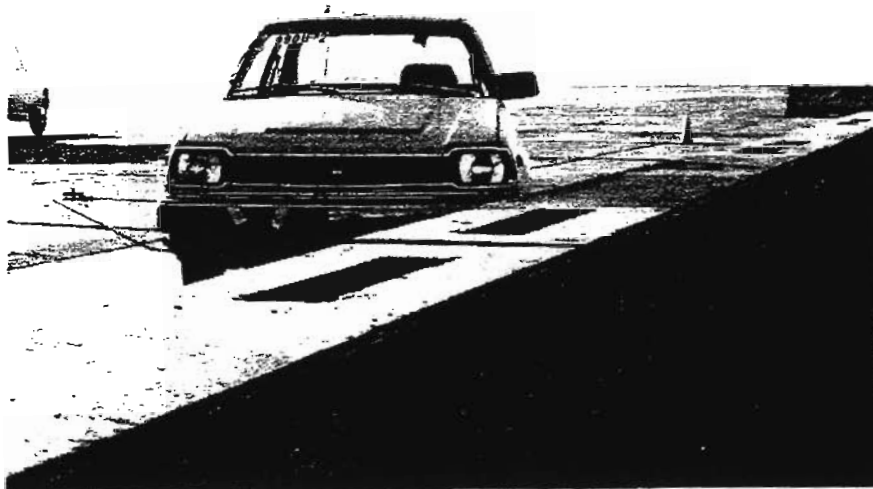

FIGURE 15 Vehicle/barrier geometrics for Test 9901F-2.

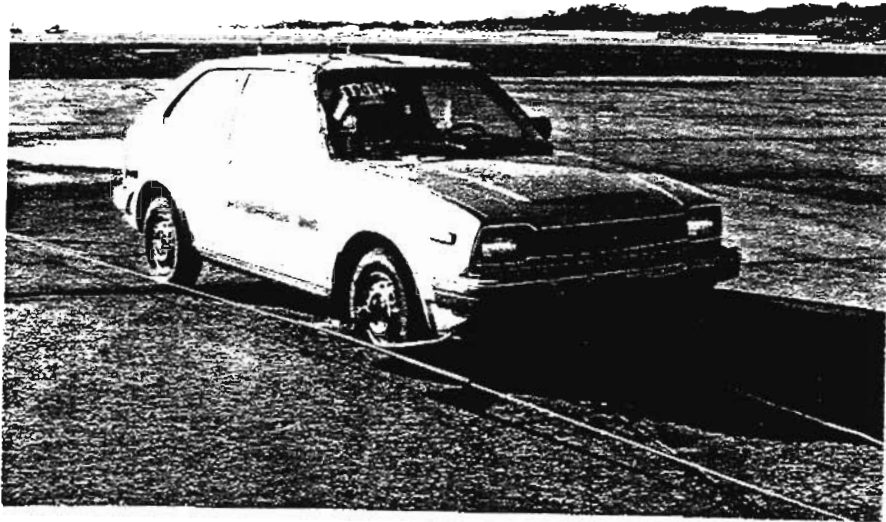

FIGURE 16 Vehicle before Test 9901F-2.

vehicle was travelling parallel to the barrier at a speed of 39.6 mi/h (63.7 km/h). The rear of the vehicle impacted the barrier at 202 msec, and the vehicle exited the barrier at 366 msec, travelling 7.4 degrees away from the barrier at a speed of 38.2 mi/h (61.5 km/h). Sequential photographs of the test are presented in Figure 22 in Appendix B.

The barrier received no significant damage as shown in Figure 17. There was no measurable lateral movement of the barrier. The vehicle sustained moderate damage to the left side as shown in Figure 18. The left strut and stabilizer bar were damaged. There was also damage to the front bumper, grill, left front quarter panel, left door, left rear quarter panel, and the rear bumper.

Data from the electronic instrumentation were digitized for evaluation and post test processing. As stated previously the impact speed was 45.7 mph (73.5 km/h), and the angle of impact was 21.3 degrees. NCHRP 230 describes occupant risk evaluation criteria, and it places limits on these for acceptable performance for tests conducted with 1,800 lb (817 kg) vehicles impacting with angles of 15 degrees (7). These limits do not apply to this set of test conditions but were computed for information only. The occupant impact velocity was 11.7 ft/s (3.6 m/s) in the longitudinal direction and 18.6 ft/s (5.7 m/s) in the lateral direction. The highest 0.010 sec average occupant ridedown accelerations were -1.1 g (longitudinal) and -8.7 g (lateral). These and other pertinent data from this test are presented in Figure 19.

Vehicle angular displacements are displayed in Figure 27 in Appendix C, and vehicular accelerations versus time traces filtered at 300 Hz are

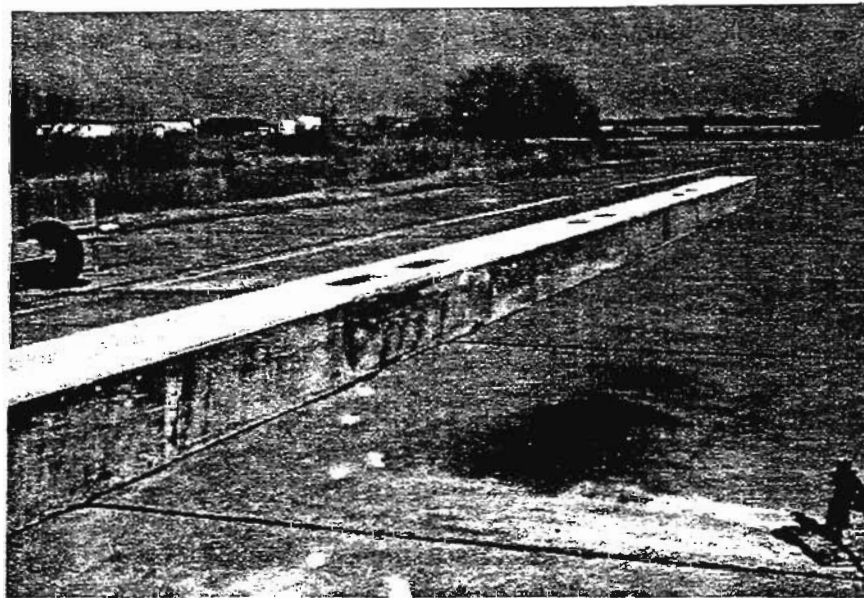
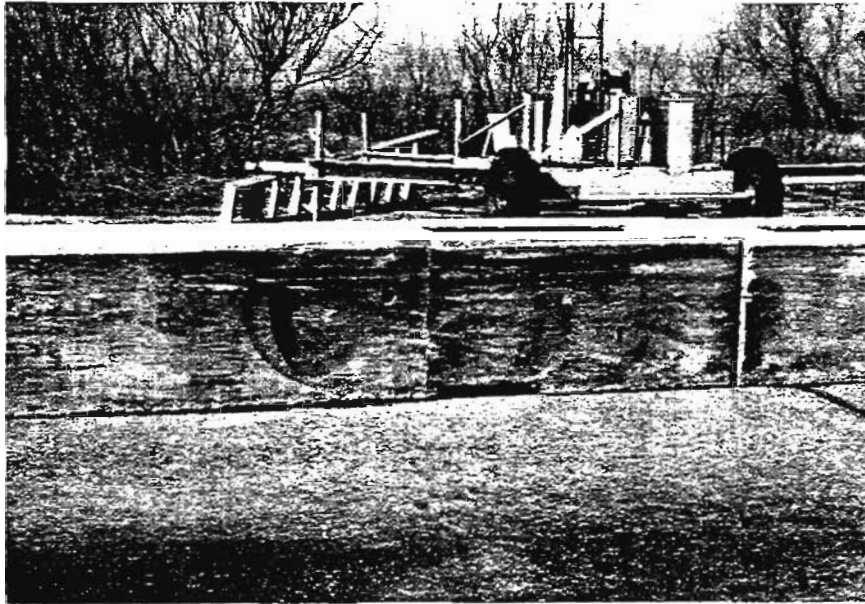

FIGURE 17 Barrier after Test 9901F-2.



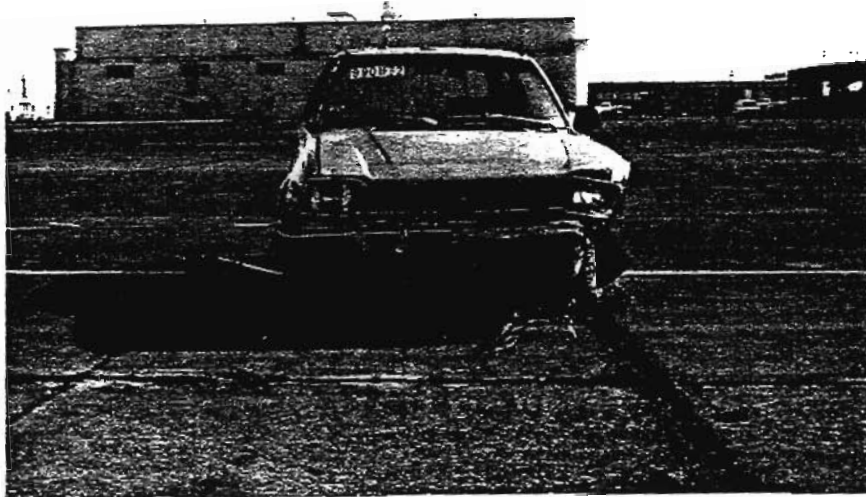
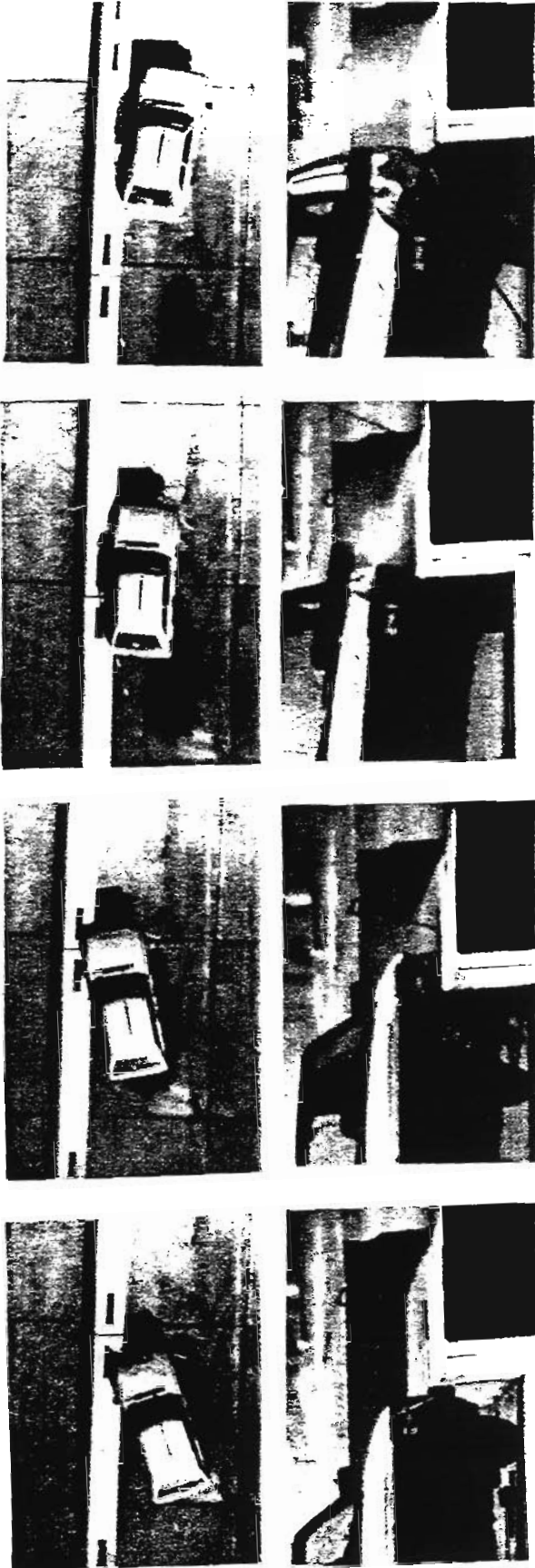

FIGURE 18 Vehicle after Test 9901F-2.

presented in Figures 28 through 30 in Appendix C. The maximum 0.050 second average accelerations measured near the center-of-gravity of the vehicle were -4.5 g (longitudinal) and -9.1 g (lateral).

After impact, the vehicle redirected and did not penetrate, vault or roll over the barrier. There was no measurable movement of the barrier. There were no detached elements or debris to show potential for penetration of the occupant compartment or to present undue hazard to other traffic. The vehicle remained upright and stable during the impact with the barrier and after exiting the test installation. There was no deformation or intrusion into the occupant compartment. The vehicle exited the barrier traveling 7.4 degrees away from the barrier. The vehicle trajectory at loss of contact indicates minimum intrusion into the adjacent traffic lanes.



Test No . . . . . 9901F-2  
 Date . . . . . 01/25/91  
 Test Installation . . . . . Low Profile Barrier  
 Installation Length . . . . . 120 ft (37 m)  
 Maximum movement . . . . . 0 in. (0 cm)  
 Vehicle . . . . . 1981 Honda Civic  
 Vehicle Weight  
 Test Inertia . . . . . 1,800 lb (817 kg)  
 Gross Static . . . . . 1,965 lb (892 kg)  
 Vehicle Damage Classification  
 TAD . . . . . 11LD3  
 CDC . . . . . 11FLEK2 & 11LDEW3  
 Maximum Vehicle Crush . . . . . 8.0 in. (20.3 cm)

Impact Speed . . . . . 45.7 mi/h (73.5 km/h)  
 Impact Angle . . . . . 21.3 degrees  
 Speed at Parallel . . . . . 39.6 mi/h (63.7 km/h)  
 Exit Speed . . . . . 38.2 mi/h (61.5 km/h)  
 Exit Trajectory . . . . . 7.4 degrees  
 Vehicle Accelerations  
 (Max. 0.050-sec Avg)  
 Longitudinal . . . . . -4.5 g  
 Lateral . . . . . -9.1 g  
 Occupant Impact Velocity  
 Longitudinal . . . . . 11.7 ft/s (3.6 m/s)  
 Lateral . . . . . 18.6 ft/s (5.7 m/s)  
 Occupant Ridedown Accelerations  
 Longitudinal . . . . . -1.1 g  
 Lateral . . . . . -8.7 g

FIGURE 19. Summary of results for Test 9901F-2.



## CONCLUSIONS

A low-profile PCB has been developed. It has been designed for impacts ranging from 1,800 lb (817 kg) compact automobiles to 4,500 lb (2,043 kg) 3/4 ton pick-ups. The test conditions for the 3/4 ton pick-up were 45 mph (73 km/h) with a 25 degree encroachment angle. The test conditions for the small car were 45 mph (73 km/h) with a 20 degree encroachment angle. It is believed that these are severe test conditions for the urban application where vehicle speeds are limited to 45 mph (73 km/h). The tests prove that the barrier can withstand these impacts without any vaulting or rolling of the vehicle and without any significant damage to the barrier.

In both full-scale crash tests, the vehicles were smoothly redirected. The largest deflection of the barrier was 5 in. (12.7 cm) resulting from the 3/4 ton pick-up impact. There was no measurable deflection in the small car test. All test results fell within acceptable limits of occupant and vehicle accelerations according to NCHRP 230 (7). Therefore, the low-profile PCB is recommended for immediate use.

The primary advantage to the low-profile PCB is that it significantly improves the site distance situation for the drivers attempting to enter or exit a work zone which is delineated with the PCB barriers. The critical sight-distance situation was judged to be lateral visibility of a cross-traffic driver attempting to enter the work zone at night. Specifically, the new low-profile PCB was designed to not interfere with the sighting of headlights of oncoming traffic at night. In addition, the day time

visibility is significantly improved. The improved visibility provided by the use of the low-profile PCB will allow drivers to see oncoming vehicles at night and in the day time and to avoid a potentially hazardous situation. While obtaining this advantage, a reasonable level of safety in the work zone is maintained by preventing the intrusion of errant vehicles into the work area.

In addition to portable applications, there may also be permanent uses for the low-profile barrier in urban situations and in some areas adjacent to freeways. The PCB can be easily converted to permanent use including slip, forming the shape without connections and/or permanently anchoring the barrier to the roadway.

The new low-profile barrier presents a major advance for urban work zones where the vehicle speeds are limited to 45 mph or less. It is perceived that there is a need for a similar low-profile barrier for higher speed applications. While the redirective capabilities of the 20 in (51 cm) low profile PCB may not be sufficient for use in high-speed work zones, it is believed that a 24 in. (61 cm) version of the low-profile barrier would be able to redirect a 4,500 lb (2,043 kg) vehicle impacting at an angle of 25 degrees with a speed of 60 mph (96 km/h). Therefore, it is suggested that future research efforts be directed toward the development and testing of a 24 in. (61 cm) full-service low-profile barrier. In addition, a significant effort needs to be expended to develop an end treatment for the new low-profile PCB.

**APPENDIX A**  
**FABRICATION DETAILS FOR**  
**THE LOW-PROFILE CMB**

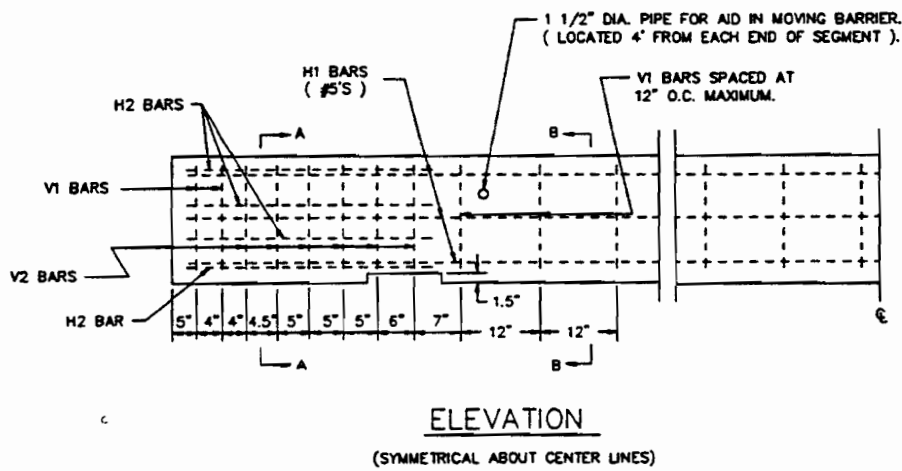
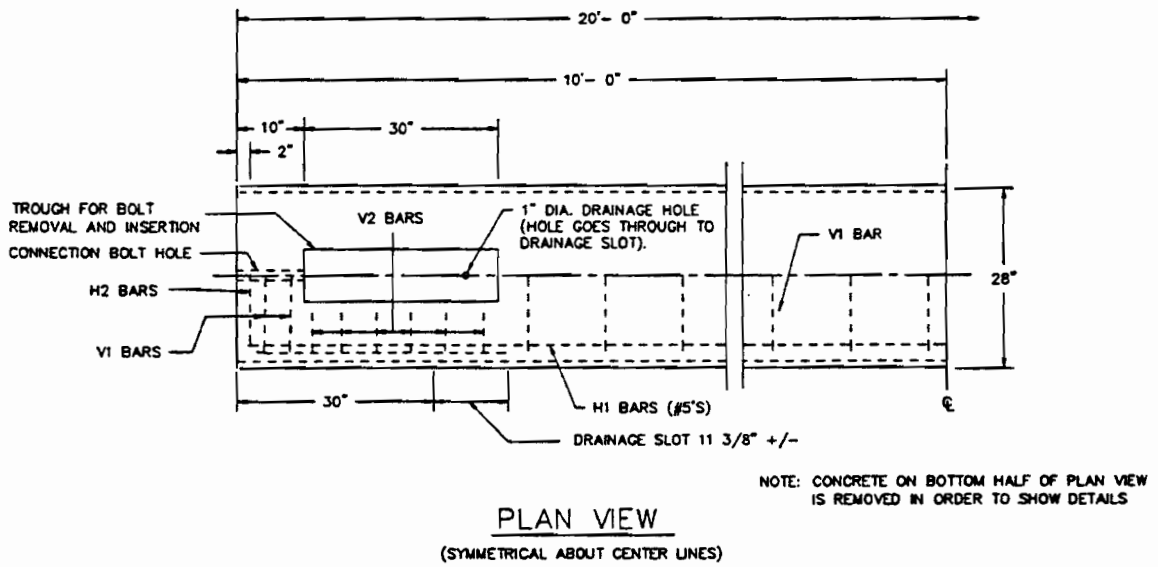
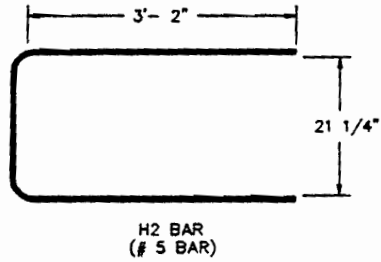

FIGURE 20 Low-Profile construction details.



NOTE: H2 REBAR IS TO BE BENT AT A 3" RADIUS.



NOTE: ALL BENDING OF SHEAR REBAR IS SPECIFIED AT A 2" RADIUS.

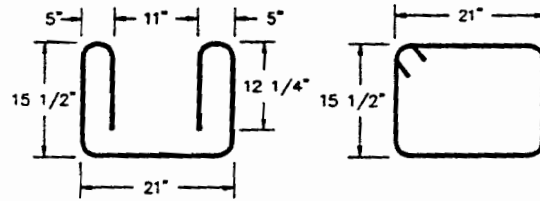

REINFORCING STEEL DETAILS

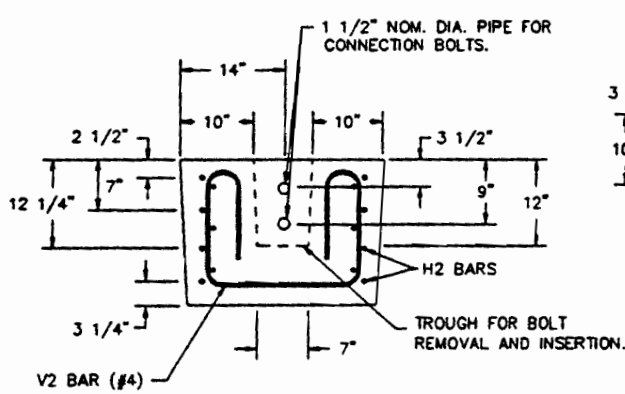

SECTION A-A

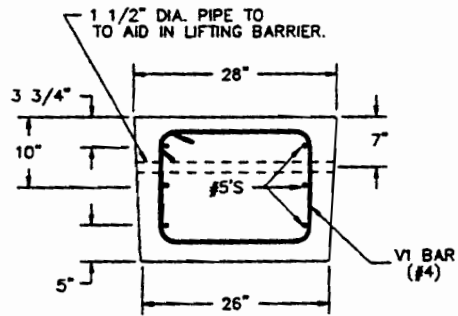

SECTION B-B

GENERAL NOTES

1. ALL CONCRETE SHALL BE CLASS A, C, OR H, UNLESS OTHERWISE SPECIFIED.
2. ALL REINFORCING STEEL SHALL BE GRADE 60, UNLESS OTHERWISE SPECIFIED.
3. CHAMFER END EDGES 3/4".

**FIGURE 20 Low-Profile construction details (continued).**

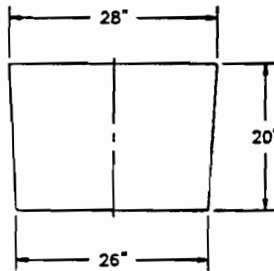

TYPICAL PROFILE

NOTE: BOLT MATERIAL IS  
ASTM A36 ROUND BAR.

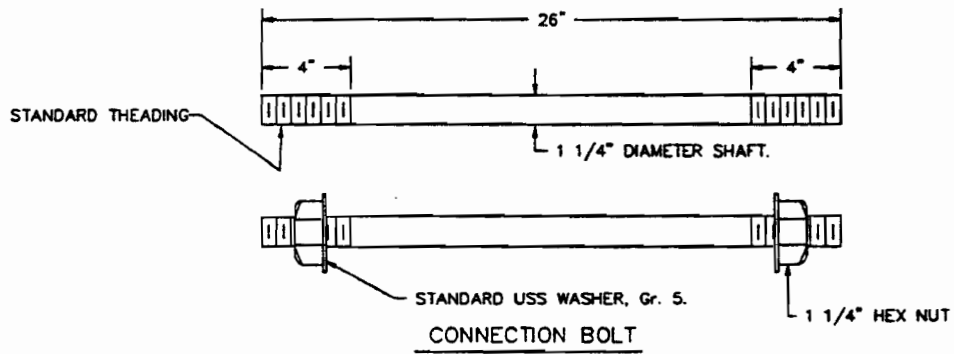
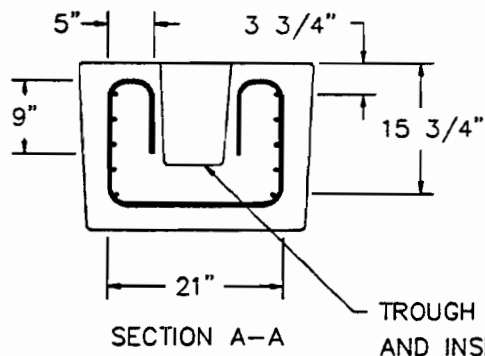

FIGURE 20 Low-Profile construction details (continued).

ALTERNATE WIRE MESH REINFORCING  
SCHEME FOR THE LOW-PROFILE PCB



Welded Wire Fabric  
3x12 - D20 x D20  
60 ksi minimum yield strength

NOTE: THIS WIRE FABRIC ALTERNATIVE CAN  
BE USED IN PLACE OF V1, V2 AND H1 BARS.  
THE H2 BARS SPECIFIED ARE STILL REQUIRED.

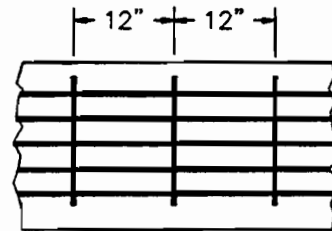
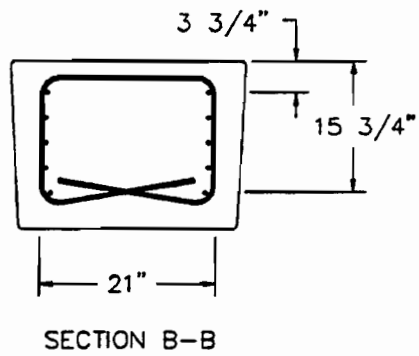
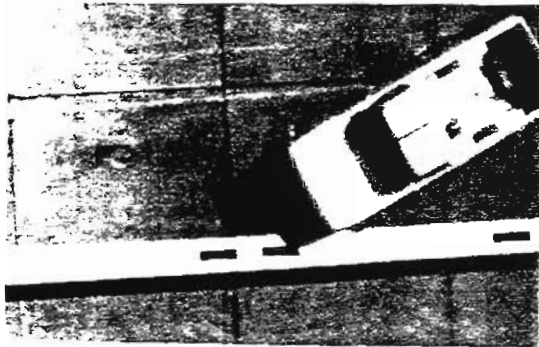

FIGURE 20 Low-Profile construction details (continued).



**APPENDIX B**  
**SEQUENTIAL PHOTOGRAPHS**  
**OF CRASH TESTS**



Impact

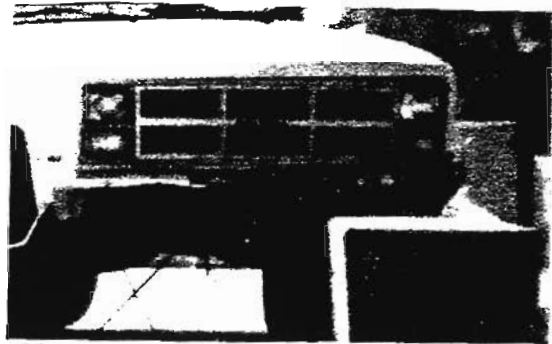
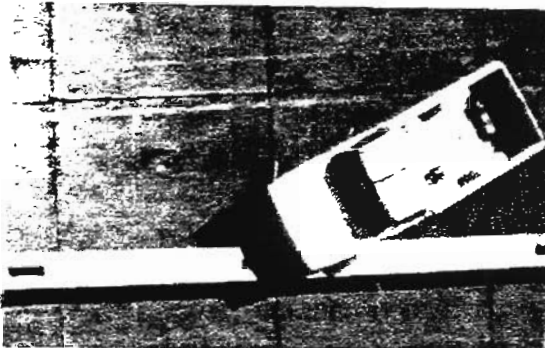

76 msec

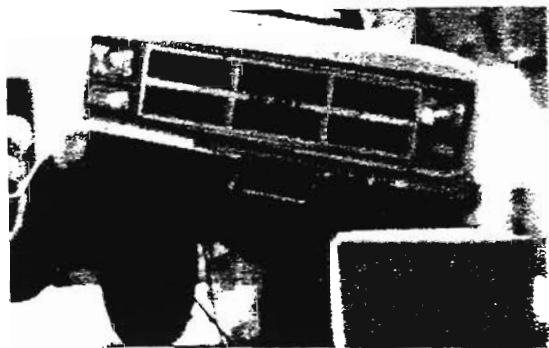
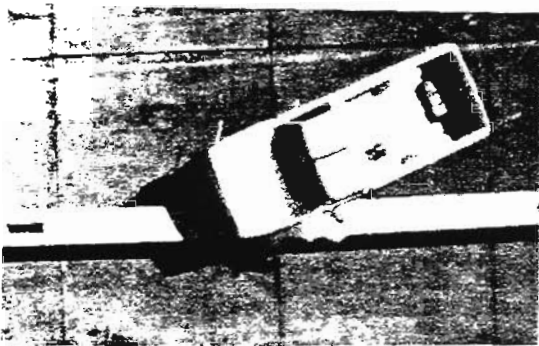

153 msec

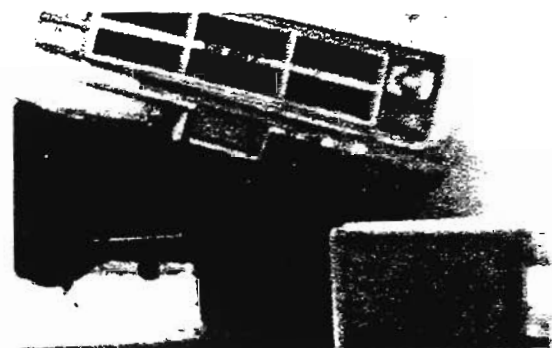
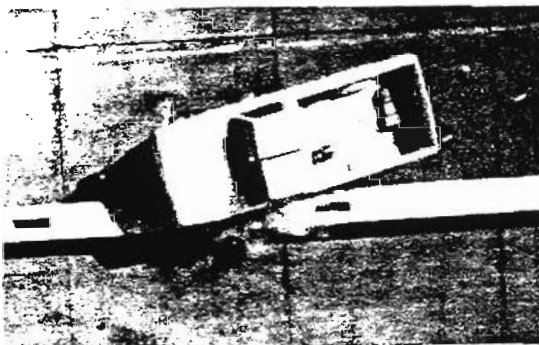

229 msec

FIGURE 21 Sequential photographs of Test 9901F-1.

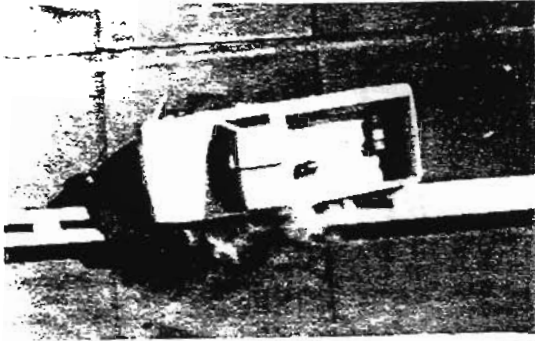

306 msec

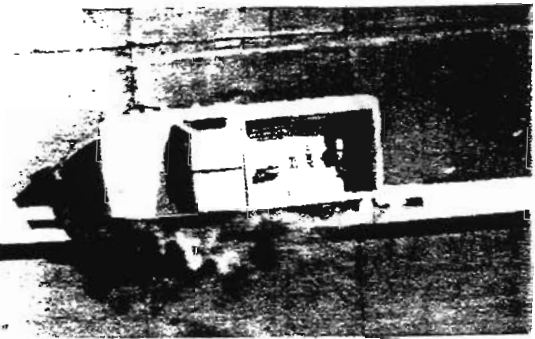
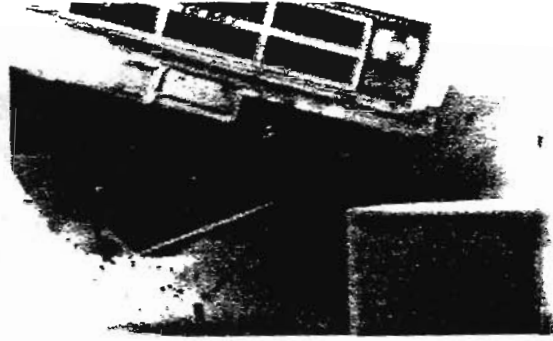

400 msec

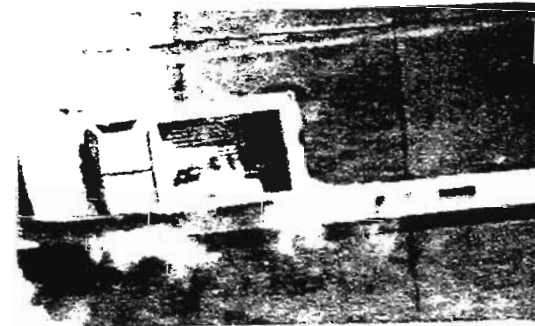
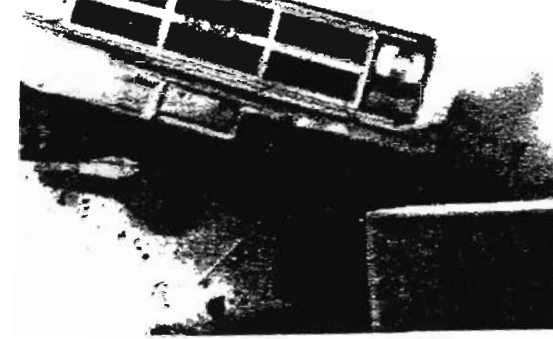

584 msec

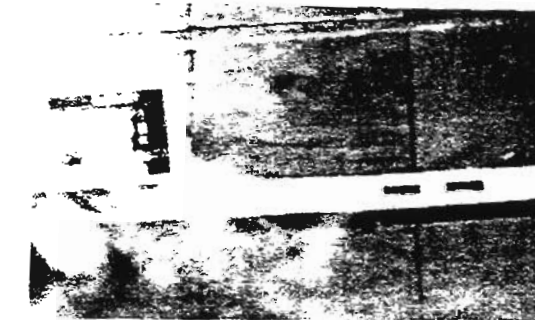
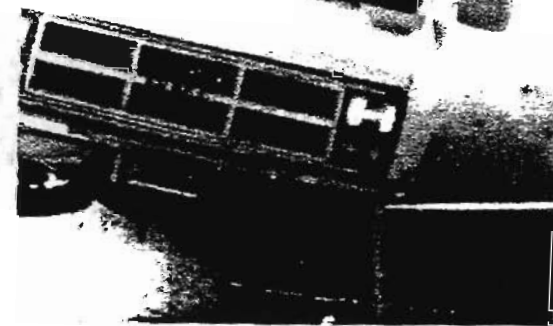

768 msec



FIGURE 21 Sequential photographs of Test 9901F-1 (continued).



Impact

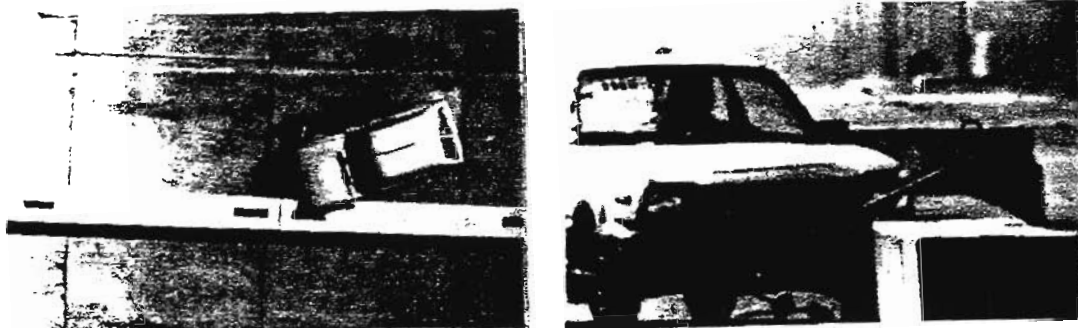

49 msec



98 msec

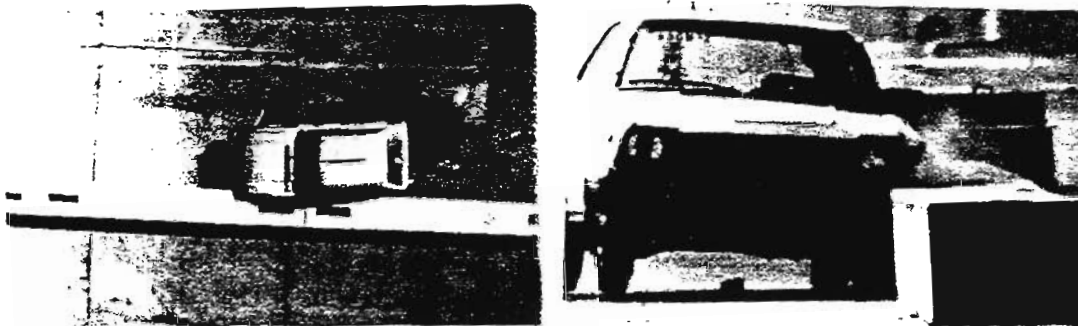

147 msec

FIGURE 22 Sequential photographs of Test 9901F-2.



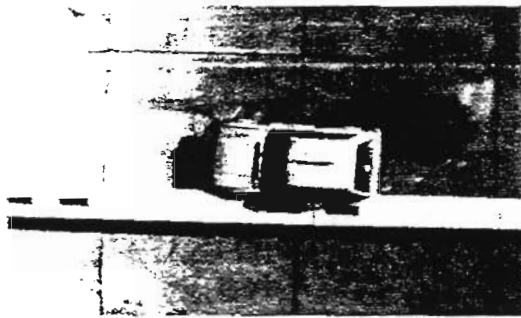

196 msec

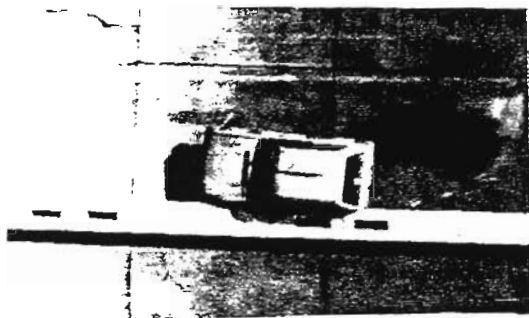

245 msec

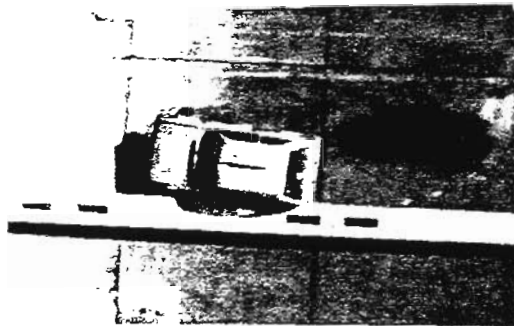
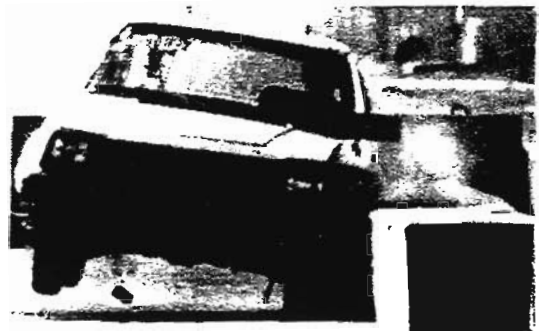

306 msec

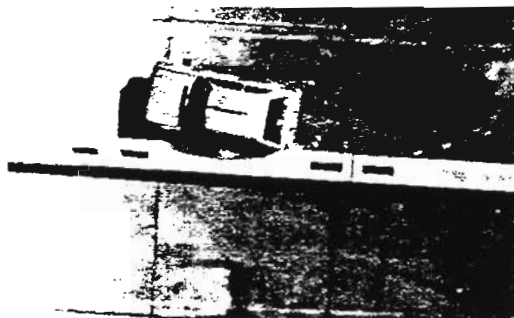

367 msec



FIGURE 22 Sequential photographs of Test 9901F-2 (continued).



APPENDIX C  
ACCELEROMETER TRACES AND  
PLOTS OF ROLL, PITCH AND  
YAW RATES

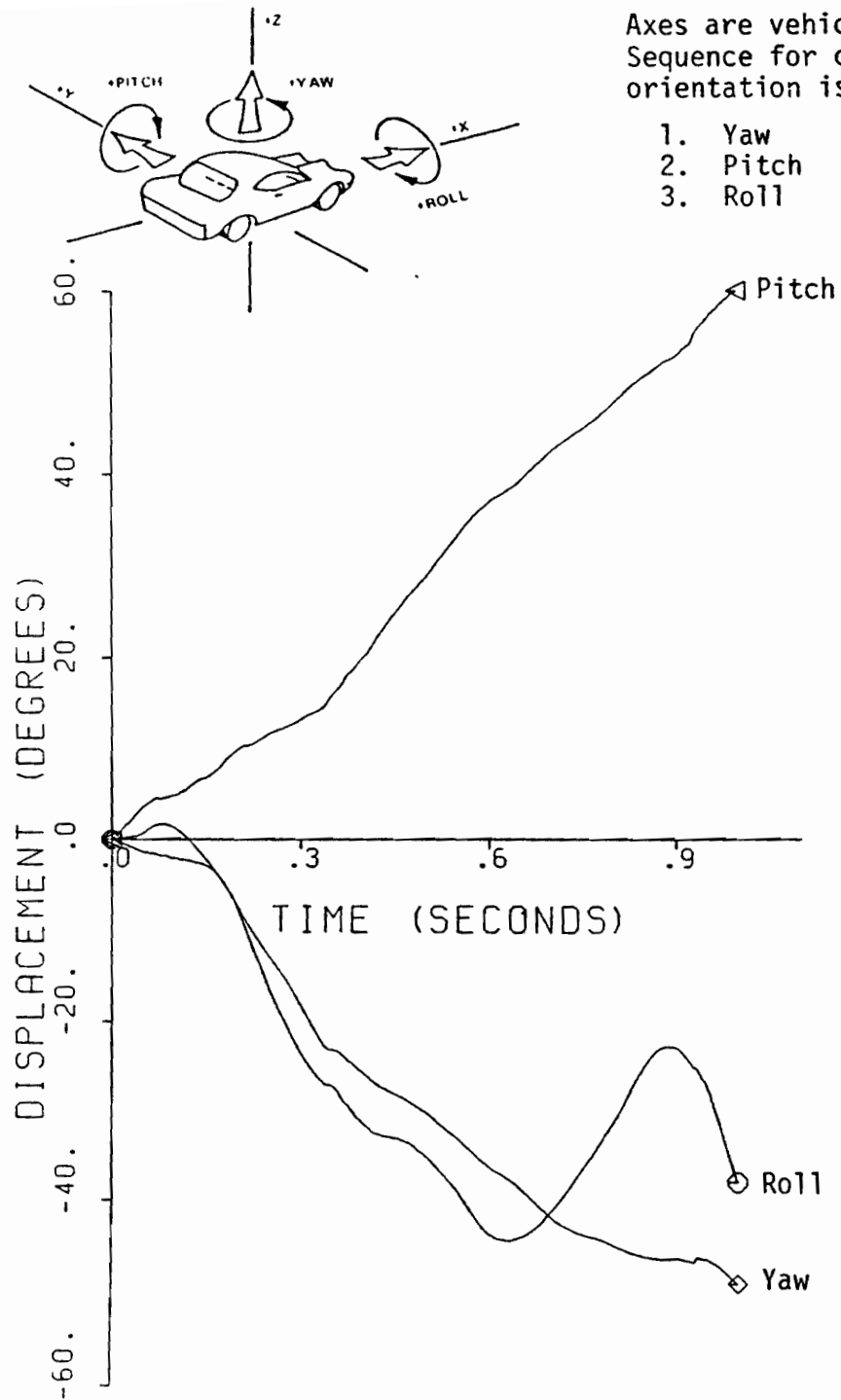

Axes are vehicle fixed.  
 Sequence for determining  
 orientation is:

1. Yaw
2. Pitch
3. Roll

FIGURE 23 Vehicle angular displacements for Test 9901F-1.

# TEST 9901F-1

Class 180 Filter - At center-of-gravity

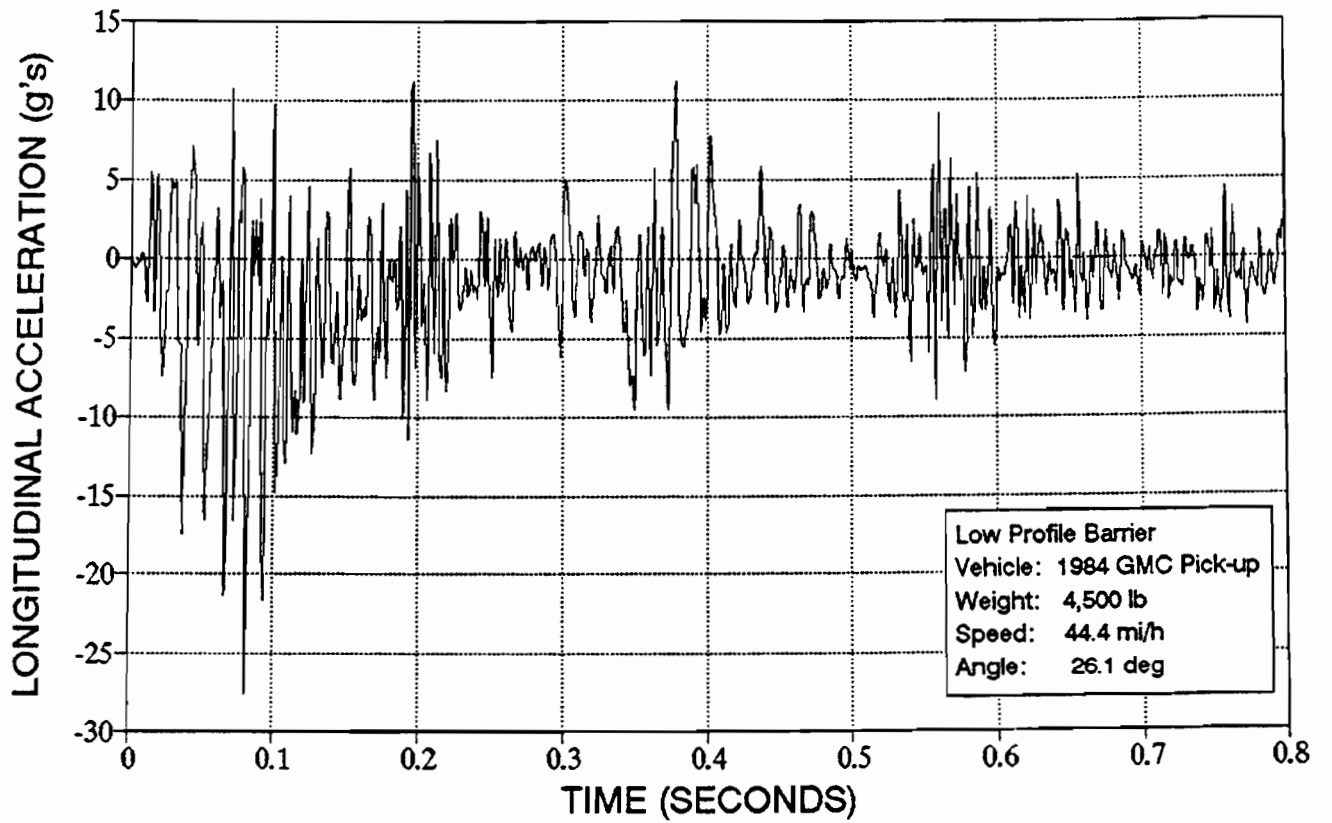

FIGURE 24 Longitudinal accelerometer trace for Test 9901F-1.

# TEST 9901F-1

Class 180 Filter - At center-of-gravity

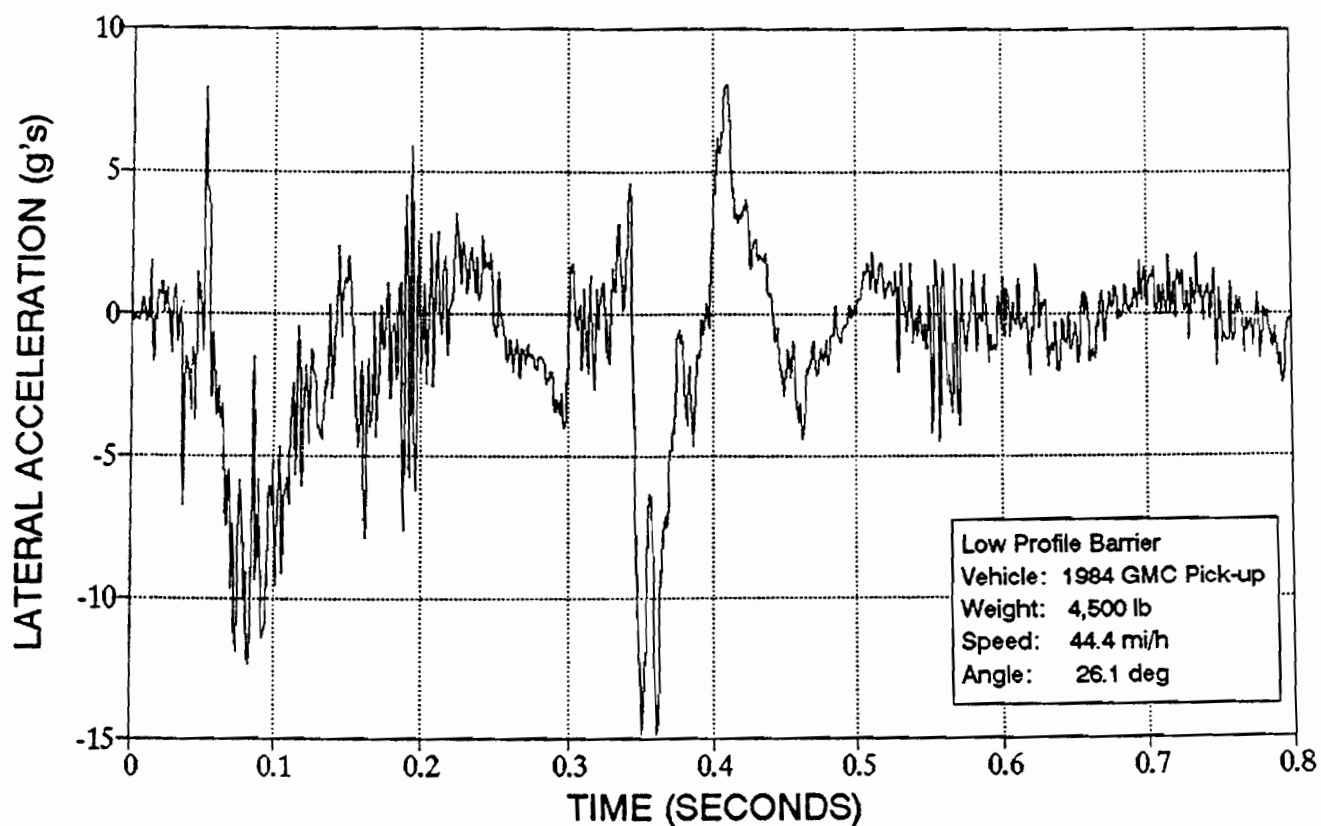

FIGURE 25 Lateral accelerometer trace for Test 9901F-1.

# TEST 9901F-1

Class 180 Filter - At center-of-gravity

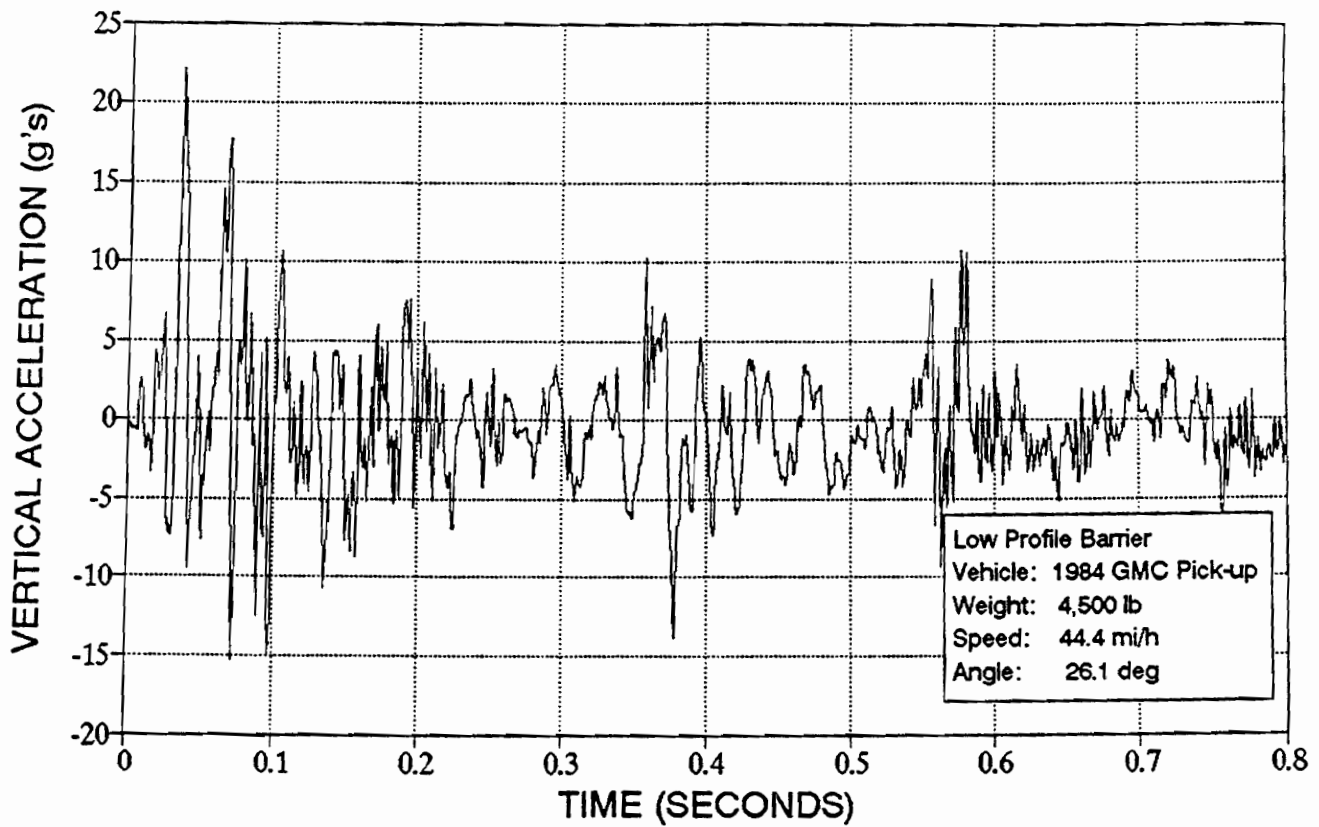
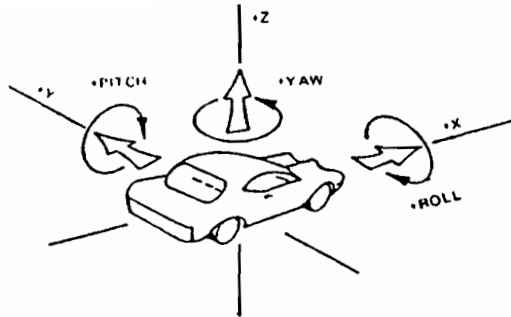

FIGURE 26 Vertical accelerometer trace for Test 9901F-1.



Axes are vehicle fixed.  
 Sequence for determining  
 orientation is:

1. Yaw
2. Pitch
3. Roll

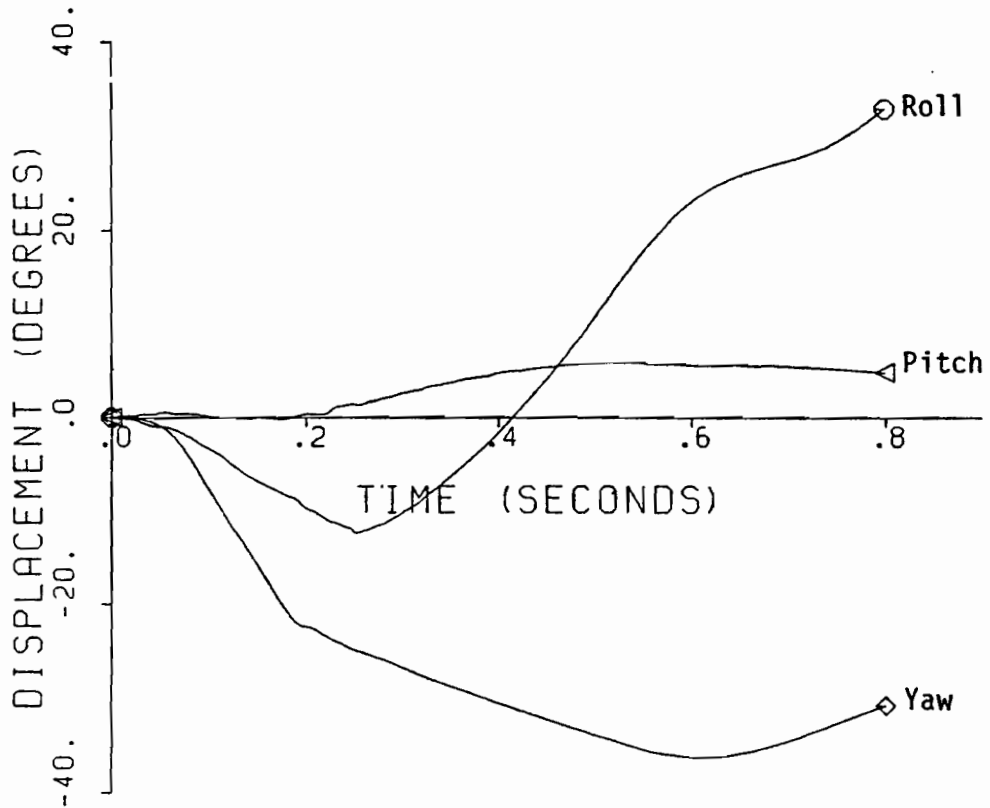

FIGURE 27 Vehicle angular displacements for Test 9901F-2.



# TEST 9901F-2

Class 180 Filter - Near center-of-grav.

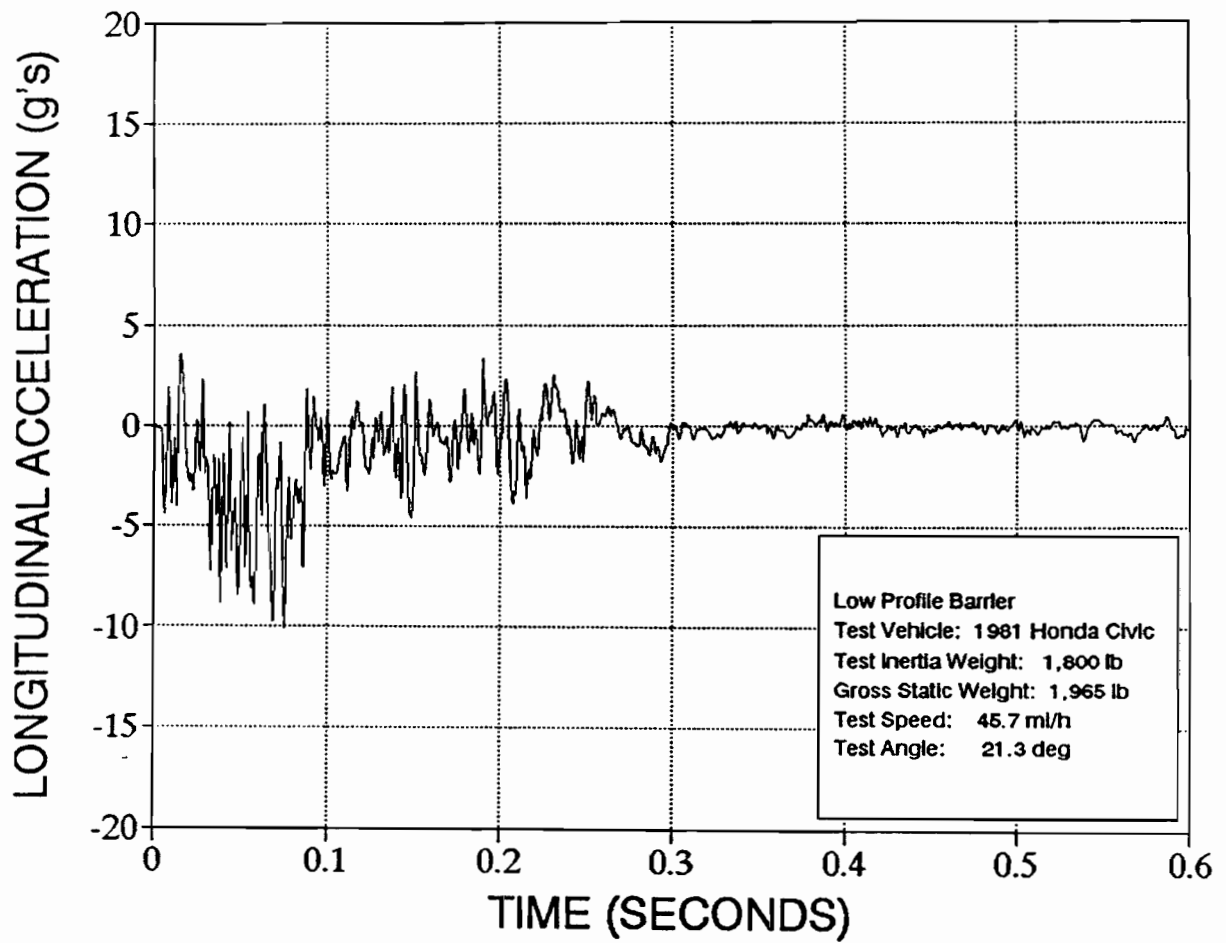

FIGURE 28 Longitudinal accelerometer trace for Test 9901F-2.

# TEST 9901F-2

Class 180 Filter - Near center-of-grav.

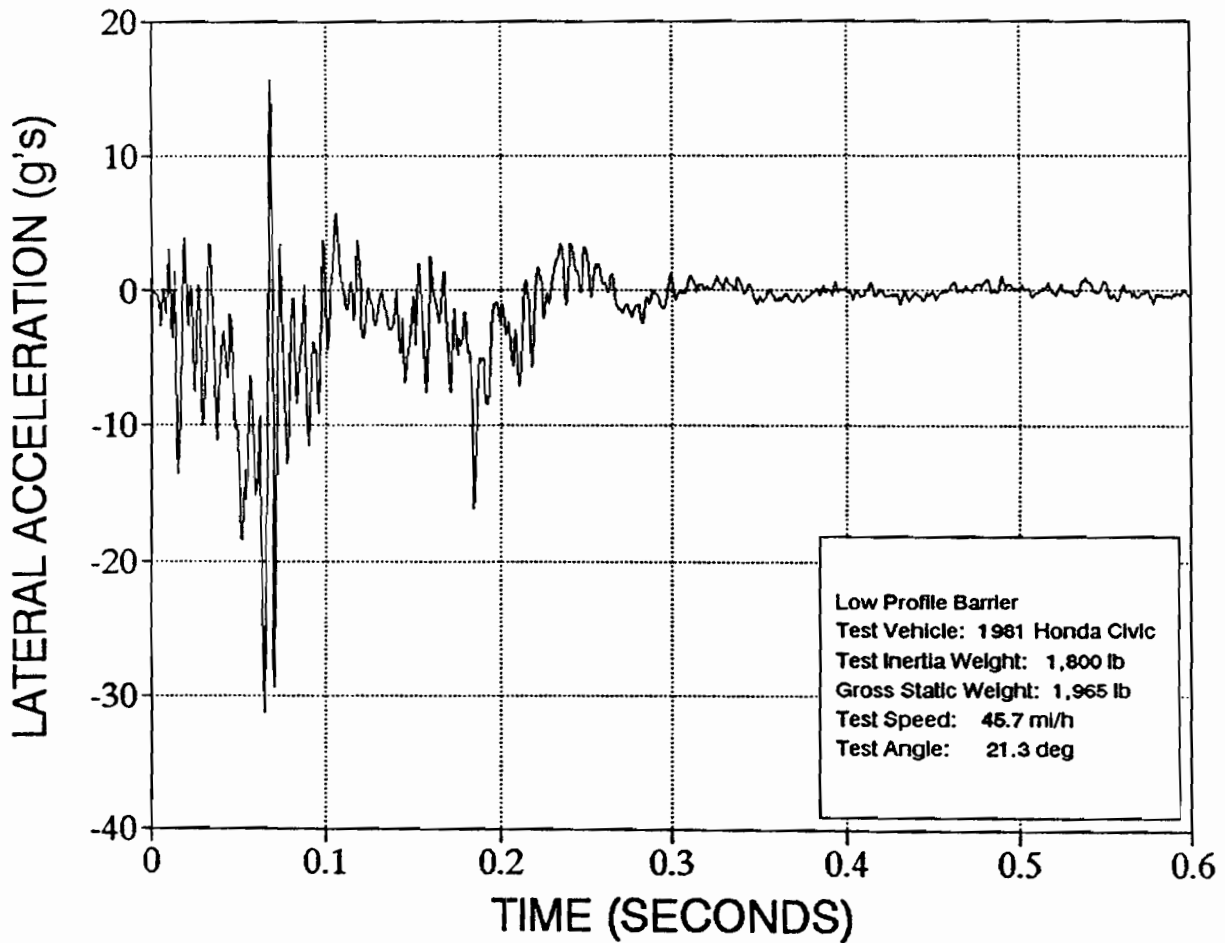

FIGURE 29 Lateral accelerometer trace for Test 9901F-2.

# TEST 9901F-2

Class 180 Filter - Near center-of-grav.

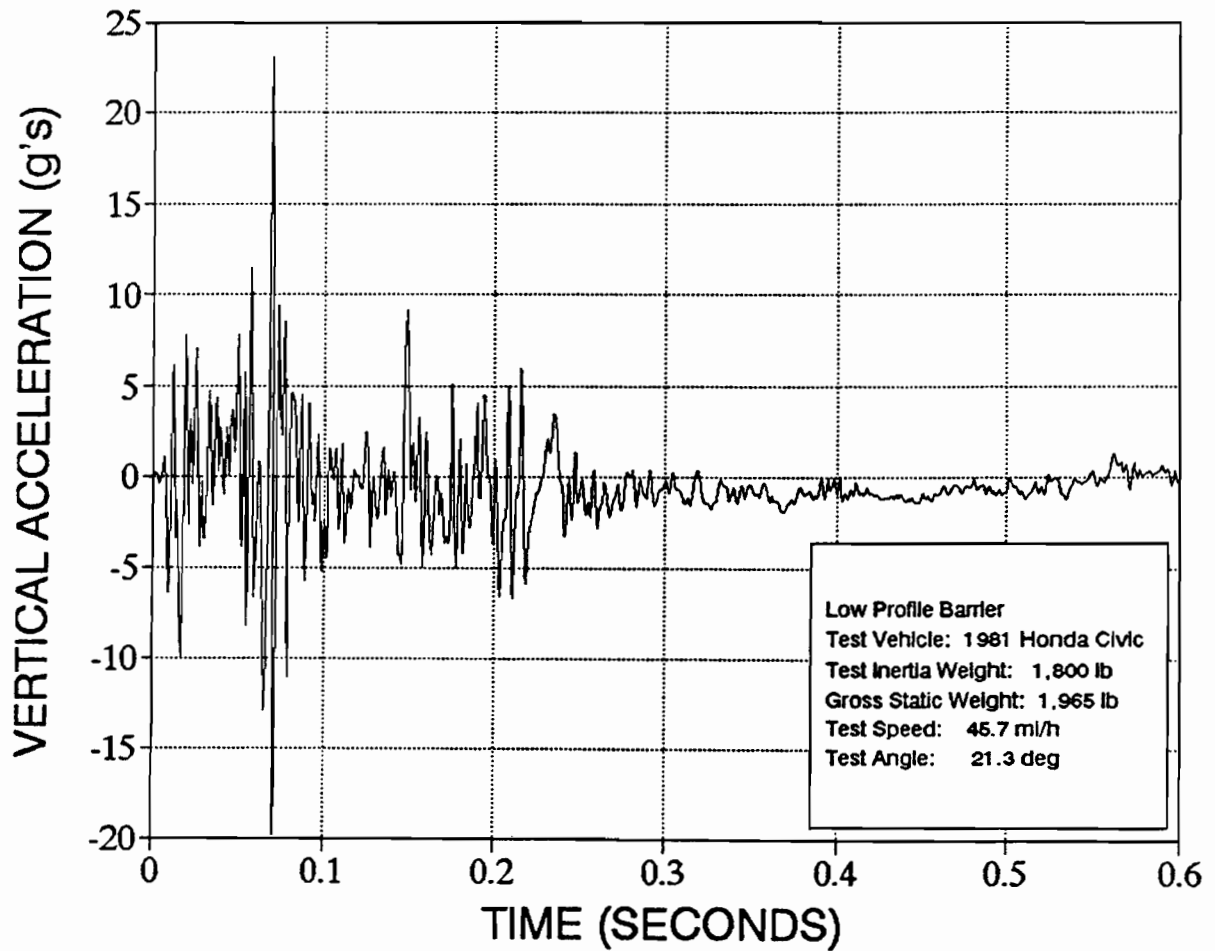

FIGURE 30 Vertical accelerometer trace for Test 9901F-2.



**APPENDIX D**  
**TEST VEHICLE PROPERTIES**

Date: \_\_\_\_\_ Test No.: 9901F-1 VIN: 1GTGC24M9EJ527146  
 Make: GMC Model: Sierra 2500 Year: 1984 Odometer: 56779.1  
 Tire Size: LT 235 Ply Rating: \_\_\_\_\_ Bias Ply:  Belted:  Radial:   
85 R16

Tire Condition: good   
 fair   
 badly worn

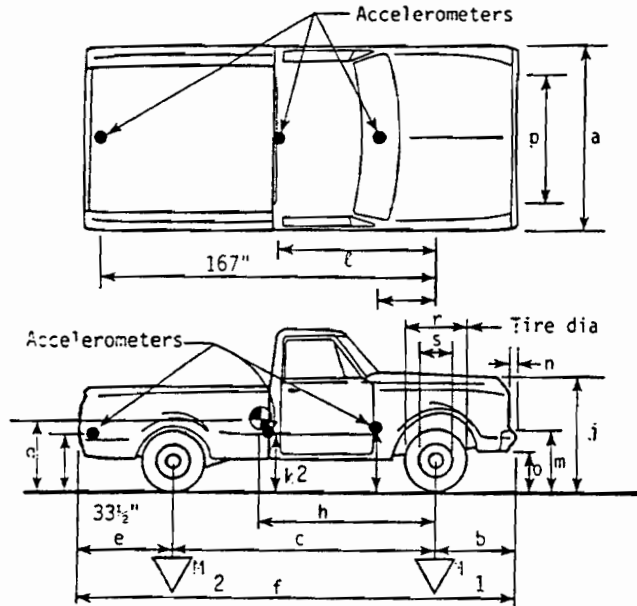

Vehicle Geometry - inches

|   |                 |    |                 |
|---|-----------------|----|-----------------|
| a | <u>79 1/2"</u>  | b  | <u>31 1/2"</u>  |
| c | <u>131 1/2"</u> | d* | <u>72"</u>      |
| e | <u>52 1/2"</u>  | f  | <u>215 1/2"</u> |
| g | _____           | h  | <u>60.49"</u>   |
| i | -----           | j  | <u>44 1/2"</u>  |
| k | <u>25 1/2"</u>  | l  | <u>60 1/2"</u>  |
| m | <u>26 1/2"</u>  | n  | <u>3 1/2"</u>   |
| o | <u>17 1/2"</u>  | p  | <u>65 1/2"</u>  |
| r | <u>31"</u>      | s  | <u>17 1/2"</u>  |

Engine Type: V-8

Engine CID: 350

Transmission Type:

~~XXXXXX~~ Manual  
~~XXXXXX~~ RWD ~~XXXXXX~~

Body Type: PU

Steering Column Collapse Mechanism:

Behind wheel units  
 Convoluted tube  
 Cylindrical mesh units  
 Embedded ball  
 NOT collapsible  
 Other energy absorption  
 Unknown

Brakes:

Front: disc  drum \_\_\_\_\_  
 Rear: disc \_\_\_\_\_ drum

4-wheel weight for c.g. det. lf 1215 rf 1215 lr 1011 rr 1059

| Mass - pounds  | Curb        | Test Inertial | Gross Static |
|----------------|-------------|---------------|--------------|
| M <sub>1</sub> | <u>2591</u> | <u>2430</u>   | _____        |
| M <sub>2</sub> | <u>1990</u> | <u>2070</u>   | _____        |
| M <sub>T</sub> | <u>4581</u> | <u>4500</u>   | _____        |

Note any damage to vehicle prior to test:

Crack Windshield (marked)

\*d = overall height of vehicle

FIGURE 31 Test vehicle properties (Test 9901F-1).

Date: \_\_\_\_\_ Test No.: 9901F-2 VIN: JHMSL4315CS004595  
 Make: Honda Model: Civic Year: 1981 Odometer: 107449.2  
 Tire Size: 155 SR12 Ply Rating: 4 Bias Ply:     Belted:     Radial: X

Tire Condition: good      
 fair X  
 badly worn    

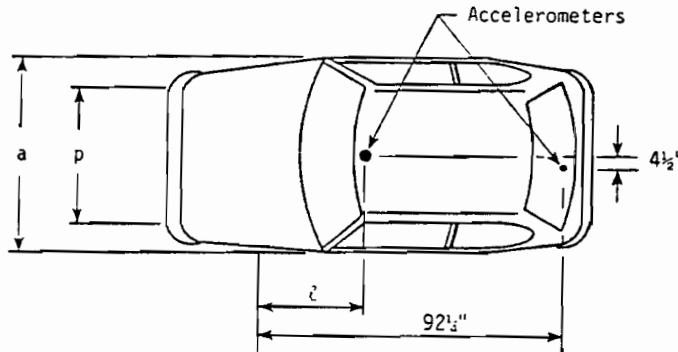

Vehicle Geometry - inches

|   |         |    |          |
|---|---------|----|----------|
| a | 62 1/2" | b  | 29 3/4"  |
| c | 88 1/2" | d* | 52 1/2"  |
| e | 28 1/2" | f  | 146 1/2" |
| g | _____   | h  | 31.67"   |
| i | ----    | j  | 28 1/4"  |
| k | 15 1/2" | l  | 29 1/2"  |
| m | 19 1/2" | n  | 3 1/2"   |
| o | 14"     | p  | 53 3/4"  |
| r | 21 1/2" | s  | 13 1/4"  |

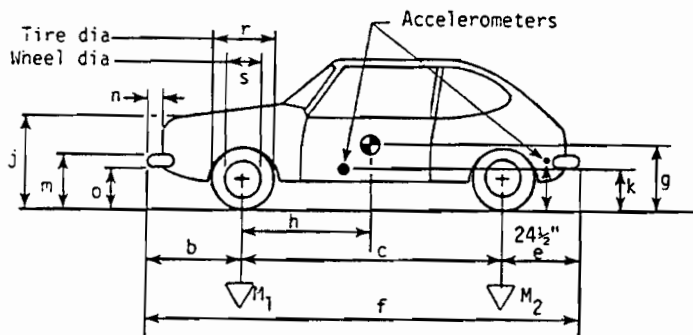

Engine Type: 4 CYL Gasoline

Engine CID: 81

Transmission Type:

~~Automatic~~ Manual  
~~FWD~~ ~~XXXXXX~~ ~~XXXXXX~~ ~~XXXXXX~~

Body Type: 3-Door

Steering Column Collapse Mechanism:

    Behind wheel units  
    Convoluted tube  
    Cylindrical mesh units  
    Embedded ball  
    NOT collapsible  
    Other energy absorption  
    Unknown

4-wheel weight for c.g. det. lf 589 rf 565 lr 338 rr 308

| Mass - pounds  | Curb        | Test Inertial | Gross Static |
|----------------|-------------|---------------|--------------|
| M <sub>1</sub> | <u>1130</u> | <u>1154</u>   | <u>1236</u>  |
| M <sub>2</sub> | <u>621</u>  | <u>646</u>    | <u>729</u>   |
| M <sub>T</sub> | <u>1751</u> | <u>1800</u>   | <u>1965</u>  |

Note any damage to vehicle prior to test:

\_\_\_\_\_  
 \_\_\_\_\_

Brakes:

Front: disc X drum    

Rear: disc     drum X

\*d = overall height of vehicle

FIGURE 32 Test vehicle properties (Test 9901F-2).





## REFERENCES

1. AASHTO, A Policy on Geometric Design of Highways and Streets, 1990, American Association of State Highway and Transportation Officials, Washington, D.C.
2. Segal, D.J., "Highway-Vehicle-Object-Simulation-Model-1976," Report Numbers FHWA-RD-75-162 through 165, 4 Volumes, Calspan Corporation, Buffalo, New York, 1976.
3. Beason, W.L., Ross, H.E., Perera, H.S., and Campise, W.L., "Development of a Single Slope Concrete Median Barrier," Final Report No. 9429C-1, Texas Department of Highways and Public Transportation, February 1989.
4. Beason, W.L., Hirsch, T.J., and Campise W.L., "Measurement of Heavy Vehicle Impact Forces and Inertia Properties," Draft Final Report for Contract DTFH61-85-00101 presented to United States Department of Transportation-Federal Highway Administration, January 1989.
5. Bronstad, M.E., Calcote, L.R., Kimball, C.E., "Concrete Median Barrier Research," 2 Volumes, Final Report No. FHWA-RD-77-4, United States Department of Transportation-Federal Highway Administration, March 1976.
6. Perera, H.S., "An Improved Simulation Program for a Portable Concrete Median Barrier," M.S. Thesis, Department of Civil Engineering, Texas A&M University, College Station, Texas, 1984.
7. Michie, J.D., "Recommended Practices for the Safety Performance Evaluation of Highway Appurtenances," NCHRP Report 230, March 1981.

