

1. Report No. TX-90-930-4		2. Government Accession No.		3. Recipient's Catalog No.	
4. Title and Subtitle An Initial Evaluation of the Feasibility of A GIS to Support PMS Applications				5. Report Date August 1989	
				6. Performing Organization Code	
7. Author(s) Emmanuel Fernando, Miguel Paredes, Tom Scullion				8. Performing Organization Report No. Research Support 930-4	
9. Performing Organization Name and Address Texas Transportation Institute The Texas A&M University System College Station, Texas 77843-3135				10. Work Unit No.	
				11. Contract or Grant No. Study No. 2-18-88-930	
				13. Type of Report and Period Covered Interim - September 1987 September 1989	
12. Sponsoring Agency Name and Address Texas State Department of Highways and Public Transportation; Transportation Planning Division P. O. Box 5051 Austin, Texas 78763				14. Sponsoring Agency Code	
15. Supplementary Notes Research performed for the State of Texas Research Study Title: District Level Pavement Management System					
16. Abstract A geographic information system (GIS) is a computerized data base management system for managing spatially defined data. Geographic information systems are rapidly gaining popularity among transportation agencies in the United States. Already, there are on-going projects within several state and federal agencies to develop transportation applications of GIS. Within the Texas SDHPT, a GIS can be used to satisfy the most urgent need of the Districts for an automated procedure to produce maps highlighting substandard pavement sections. In an initial effort to evaluate the feasibility of a geographic information system for the Department, an existing research study entitled "District Level PMS" was modified to include a task to accomplish the following: 1) identify requirements for a GIS within the Texas SDHPT; 2) identify sources of digital cartographic data for developing the GIS land base; 3) evaluate the capabilities of the Department to build and maintain a land base for the GIS; 4) review available GIS hardware and software; and 5) formulate recommendations for implementing a GIS within the Texas SDHPT. The findings from the study, as related to the objectives set forth previously, are summarized in this report. In addition, the report provides an overview of GIS, and reviews on-going efforts being conducted at the state and federal levels to implement geographic information systems for transportation applications. Issues in GIS implementation are also identified that are crucial to the successful implementation of this technology within a state transportation agency. A demonstration of the potential applications of GIS to pavement management was also conducted during the study and is documented in this report.					
17. Key Words GIS, Pavement Management System, Geographic Information System, Spatially Defined Data Management			18. Distribution Statement No restrictions. This document is available to the public through the National Technical Information Service 5285 Port Royal Road Springfield, Virginia 22161		
19. Security Classif. (of this report) Unclassified		20. Security Classif. (of this page) Unclassified		21. No. of Pages 80	22. Price

**AN INITIAL EVALUATION OF THE FEASIBILITY OF
A GIS TO SUPPORT PMS APPLICATIONS**

by

**Emmanuel Fernando
Miguel Paredes
Tom Scullion**

Research Report 0930-4

Research Study Number 2-18-88-930

Study Title "District Level Pavement Management System"

Conducted for

**Texas State Department of Highways and
Public Transportation**

by

Texas Transportation Institute

August, 1989

METRIC (SI*) CONVERSION FACTORS

APPROXIMATE CONVERSIONS TO SI UNITS

Symbol	When You Know	Multiply By	To Find	Symbol
LENGTH				
in	inches	2.54	millimetres	mm
ft	feet	0.3048	metres	m
yd	yards	0.914	metres	m
mi	miles	1.61	kilometres	km

AREA				
in ²	square inches	645.2	millimetres squared	mm ²
ft ²	square feet	0.0929	metres squared	m ²
yd ²	square yards	0.836	metres squared	m ²
mi ²	square miles	2.59	kilometres squared	km ²
ac	acres	0.395	hectares	ha

MASS (weight)				
oz	ounces	28.35	grams	g
lb	pounds	0.454	kilograms	kg
T	short tons (2000 lb)	0.907	megagrams	Mg

VOLUME				
fl oz	fluid ounces	29.57	millilitres	mL
gal	gallons	3.785	litres	L
ft ³	cubic feet	0.0328	metres cubed	m ³
yd ³	cubic yards	0.0765	metres cubed	m ³

NOTE: Volumes greater than 1000 L shall be shown in m³.

TEMPERATURE (exact)				
°F	Fahrenheit temperature	5/9 (after subtracting 32)	Celsius temperature	°C

APPROXIMATE CONVERSIONS TO SI UNITS

Symbol	When You Know	Multiply By	To Find	Symbol
LENGTH				
mm	millimetres	0.039	inches	in
m	metres	3.28	feet	ft
m	metres	1.09	yards	yd
km	kilometres	0.621	miles	mi

AREA				
mm ²	millimetres squared	0.0016	square inches	in ²
m ²	metres squared	10.764	square feet	ft ²
km ²	kilometres squared	0.39	square miles	mi ²
ha	hectares (10 000 m ²)	2.53	acres	ac

MASS (weight)				
g	grams	0.0353	ounces	oz
kg	kilograms	2.205	pounds	lb
Mg	megagrams (1 000 kg)	1.103	short tons	T

VOLUME				
mL	millilitres	0.034	fluid ounces	fl oz
L	litres	0.264	gallons	gal
m ³	metres cubed	35.315	cubic feet	ft ³
m ³	metres cubed	1.308	cubic yards	yd ³

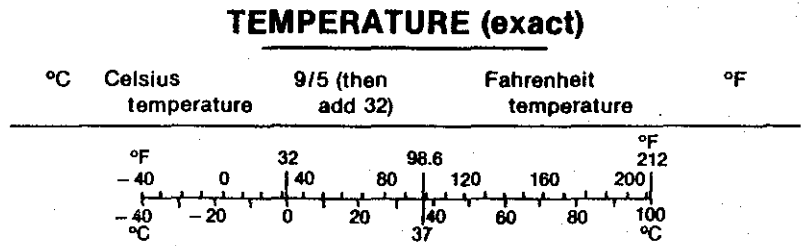

These factors conform to the requirement of FHWA Order 5190.1A.

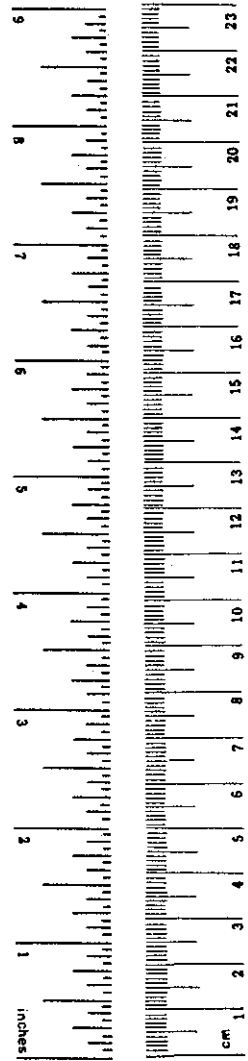

* SI is the symbol for the International System of Measurements

ABSTRACT

A geographic information system (GIS) is a computerized data base management system for managing spatially defined data. Geographic information systems are rapidly gaining popularity among transportation agencies in the United States. Already, there are on-going projects within several state and federal agencies to develop transportation applications of GIS. Within the Texas SDHPT, a GIS can be used to satisfy the most urgent need of the Districts for an automated procedure to produce maps highlighting substandard pavement sections. In an initial effort to evaluate the feasibility of a geographic information system for the Department, an existing research study entitled "District Level PMS" was modified to include a task to accomplish the following: 1) identify requirements for a GIS within the Texas SDHPT; 2) identify sources of digital cartographic data for developing the GIS land base; 3) evaluate the capabilities of the Department to build and maintain a land base for the GIS; 4) review available GIS hardware and software; and 5) formulate recommendations for implementing a GIS within the Texas SDHPT.

The findings from the study, as related to the objectives set forth previously, are summarized in this report. In addition, the report provides an overview of GIS and reviews on-going efforts being conducted at the state and federal levels to implement geographic information systems for transportation applications. Issues in GIS implementation are also identified that are crucial to the successful implementation of this technology within a state transportation agency. A demonstration of the potential applications of GIS to pavement management was also conducted during the study and is documented in this report.

DISCLAIMER

This report is not intended to constitute a standard, specification, or regulation, and does not necessarily represent the views or policies of the Federal Highway Administration or the Texas State Department of Highways and Public Transportation.

PREFACE

Project 930 "District Level PMS" was initiated in September 1987 to provide continuation in the Department's ongoing Pavement Management effort. Other reports in this study include:

Report 930-1 "Micro-PES Release 1.0, User's Manual" presents a users manual for a microcomputer system developed for the Texas SDHPT for analyzing the annual Pavement Evaluation System pavement condition data. Analysis tools include a procedure to make one-year Maintenance and Rehabilitation (M&R) estimates, the RAMS-District Optimization Program, and a procedure for estimating routine maintenance requirements.

Report 930-2 "Pavement Management, Where Do We Go From Here?" presents a plan on how the Texas SDHPT can proceed with its PMS efforts to meet both Federal and Departmental requirements. The departmental requirements were identified by interviews with the Administration, senior engineers and the staff of six Districts. Also a questionnaire was completed by all 24 Districts.

Report 930-3 "RAMS-DOI as a Decision Analysis Tool," describes the evaluation of the RAMS District Optimization Program in selecting projects to maximize network benefit. A case study was conducted in which the decisions made by a specific Texas District to allocate its maintenance and rehabilitation funds were compared with those determined from the optimization algorithm. The case study indicated that the RAMS-DOI Program has great potential for assisting the Districts in project programming.

TABLE OF CONTENTS

CHAPTER	Page
INTRODUCTION	1
BACKGROUND	3
ISSUES IN GIS DEVELOPMENT AND IMPLEMENTATION	22
DEVELOPING THE GEOGRAPHIC DATA BASE FOR A GIS	28
COMPARISON OF AVAILABLE GIS SOFTWARE	54
EXAMPLE DEMONSTRATION OF A GIS USING PC ARC/INFO	58
RECOMMENDATIONS FOR FUTURE RESEARCH	68
REFERENCES	71
APPENDIX A - UNITED STATES NATIONAL MAP ACCURACY STANDARDS . .	73

1. INTRODUCTION

In a recent review of pavement management system (PMS) needs within the Texas State Department of Highways and Public Transportation (SDHPT), it was determined that, by far, the most urgent need of the districts is the production of maps highlighting sub-standard pavement sections (Scullion, 1988). It was found that the districts have a need for accessing, manipulating, analyzing, displaying, and reporting information on the road network graphically. The automated production of graphics output in the form of maps to convey information on the highway network is at the top of the priority list of PMS needs identified by the districts. A geographic information system (GIS) presents a way by which this need can be satisfied.

While most operational data bases display information in a tabular format, a GIS displays information graphically and is commonly used with a computer terminal having graphics capabilities, where the user sees a geographic map of an area referenced by the data base. A GIS presents a new approach for managing information on infrastructure systems such as a highway network. Within a GIS, digitized maps are used to display information on any given segment of the highway network. By zooming in or out, a user can access, display, and manipulate information associated with certain locations in the map display. Different types of information, such as traffic, safety, and pavement condition data, are stored within different layers that use a common reference scheme, thereby allowing for integration of the data within the GIS.

Applications of a GIS are enormous and the capability for presenting information visually, in a manner that the user can readily comprehend, is a distinct advantage over other data base management systems that present information in a tabular format. Examples of specific GIS applications identified by the Department include:

1. Production of color coded maps showing pavement sections satisfying certain selection criteria (e.g., Present Serviceability Index (PSI) < 2.5 and average Daily Traffic (ADT) > 10,000).
2. Automation of the Department's truck routing activities.

3. Formulation of a list of projects for maintenance, rehabilitation, or widening purposes.

In view of the significant interest by the districts in applications of graphics for pavement management activities, an existing SDHPT research project entitled "District Level Pavement Management System" (Project 930) was modified to incorporate a small-scale feasibility study aimed at the following:

1. To identify user requirements for a GIS within the Texas SDHPT.
2. To evaluate the Department's existing capabilities for implementing GIS technology.
3. To review existing sources of digital spatial data for developing the land base for a GIS.
4. To conduct a literature survey of existing hardware and software for implementing a GIS.
5. To provide specific recommendations for implementing GIS technology to support pavement management activities within the Department.

The feasibility study was conducted primarily for the Maintenance and Operations Division (D-18) of the Texas SDHPT, under which Project 930 was funded. Consequently, the feasibility study was directed primarily at identifying user requirements for a GIS as related to the primary concerns of D-18. It is recognized that other divisions of the Texas SDHPT may have needs for which a GIS might be applicable. However, the identification of user requirements for a GIS in the other divisions of the department is beyond the scope of this small-scale feasibility study. To address the development of a Department-wide GIS requires a much larger study involving the identification of user and data requirements on a Department-wide basis and the development of a time table for GIS implementation within the Texas SDHPT. In addition, a policy to guide the development of a Department-wide GIS needs to be established and a committee set up to oversee the development and implementation efforts.

2. BACKGROUND

Within a state transportation agency, it is not uncommon to find large amounts of diverse information being collected and maintained to manage the highway network. Data on pavement condition, traffic, accidents, and highway geometry, to name a few, are collected periodically. In addition, ancillary information on culvert locations, guardrail status, roadway postings, and bridge condition may be collected and maintained.

Depending on the applications for which the data will be used, the responsibility for collecting the required information will, in many instances, not be borne by a single entity within a highway department. Typically, various divisions within the organization will have different data requirements for carrying out their intended functions. Consequently, it is not uncommon to find various entities within a highway department collecting and maintaining data needed to satisfy particular objectives. This situation usually results in data being scattered in different locations within an organization. For example, pavement condition data may be collected and maintained by a Pavement Evaluation unit, accident data by a Safety unit, and traffic data by a Planning unit. However, in order to make sound decisions, the highway administration needs to have access to all the pertinent data available and be able to draw a clear picture of the overall needs of the highway and bridge network.

Geographic information systems (GIS) present a novel approach for managing the large and diverse information needed to support decisions affecting the highway and bridge infrastructure. Through a GIS, data collected throughout a transportation agency can be integrated to support both analysis and graphics applications. This technology is rapidly gaining popularity among transportation agencies in the United States. Already there are on-going projects within several agencies at the state and federal levels that are directly related to the development and implementation of a GIS. To mention several examples, state DOT's in North Carolina, Ohio, New Mexico, Pennsylvania, Colorado, Wisconsin, Kansas, California, and Alaska, are in various stages of implementing geographic information systems to serve a variety of transportation

applications. In addition, the Federal Highway Administration (FHWA), through its development and dissemination of a package known as GRIDS, has effectively introduced states to GIS, showing state DOT's the potential applications of this technology to the field of transportation.

Geographic information systems are expected to play a major role in the daily operations of state transportation agencies in the immediate future. In order to introduce this technology, the present chapter has been written to provide an overview of GIS and to review GIS activities at the state and federal levels. In what follows, a definition of GIS is given, GIS concepts are presented, GIS elements are discussed, and the development of transportation applications of GIS within several state DOT's and the federal government are reviewed.

GIS DEFINITION AND CONCEPTS

A Geographic Information System is a computerized data base management system especially developed for managing spatially defined data. As such, its data base contains information on spatially-distributed entities (geographic data) that occur as points, lines, or polygons; and tools for capturing, storing, retrieving, displaying, inter-relating, and analyzing locational as well as non-locational data. Geographic Information Systems have traditionally been used in the areas of natural resources management, land records management, utilities management, and environmental resources management to name a few.

There are three basic characteristics that are inherent of spatial data: (a) the positional location in geographic space where it resides; (b) the attributes that describe what it is, e.g., name, color, classification, etc.; and (c) variation through time.

Since both positional and attribute data can change independently from each other with respect to time, the management of geographic data can become a complex matter. The geographic data base should be able to manage the locational as well as the non-locational (attribute data) characteristics of the data. This can be done in different ways. For instance, in some systems locational data is treated as another attribute together with non-locational data and processed by the same data base. In other systems locational and non-locational data are kept separate and

managed likewise. The latter approach provides for better flexibility in handling data changes associated with time (Dangermond, 1983).

As mentioned above, geographic data occurs in three forms: points, lines, and polygons. For example, forest stands and soil types occur on land and are represented on maps as areas or polygons, rivers and roads as lines (or scrawny polygons), oil wells and electrical power transmission towers as points.

The National Committee for Digital Cartographic Standards (Moellering, 1986) defines points, lines, and rings (polygons) formally, together with other cartographic elements that derive from them:

- point- a 0-dimensional object that specifies geometric location. A set of coordinates specifies the location.
- node- a 0-dimensional object that is a topological junction and may specify geometric location. An optional set of coordinates specifies the location.
- line segment- a 1-dimensional object that is a direct line between two points.
- string- a sequence of line segments
- chain- a direct sequence of nonintersecting line segments with nodes at each end. (Reference to left and right identifiers is optional.)
- ring- a 2-dimensional object made of a sequence of nonintersecting chains or strings with closure (Alias: polygon.)

Chains become the basic units for representing linear and areal features on a GIS. They form the links on a network of roads or streams, or borders on a network of deer habitats (Dueker, 1987).

The topological data structure which is inherent to GIS ensures the integrity and completeness of geographic data while the cartographic x,y coordinates are used to identify spatial entity location. Topology not only identifies nodes, chains, and polygons, but it also describes the spatial relationships between them. Through topology, a GIS "understands" the principles of adjacency, proximity, containment, and connectedness: Are these two entities close together, side by side, or

far away?

The topological model in a GIS also allows the application of a powerful analytical tool known as cartographic modeling. This model permits the analysis of information across map layers in a GIS. Through this feature, two maps of the same geographic area containing distinct data can be overlaid to generate a third map. Attributes from the two separate maps are combined and automatically associated with the new map.

The concepts presented in the above paragraphs suggest that GIS should not be viewed just as a system but as a technology. Its many spatial data handling capabilities can be assembled to deal with a myriad of user specific needs.

ELEMENTS OF A GIS

The main elements of any GIS are its data base models. As mentioned earlier, geographic data possesses three inherent characteristics: position, description, and variation with time. The time component can be handled by progressive updating of the geographic element's position and/or description as they occur, or if applicable, by time modeling algorithms, e.g., how will a habitat area change due to flooding during the upcoming rainy season?

The descriptive component of the geographic element is maintained in an attribute data base, while the positional component of the element, which is described by its geographic coordinates and by its topological relationship to other elements, is maintained in a geographic data base.

The Geographic Data Base

The geographic data base can be structured in either grid (raster), vector, or triangulated irregular network (TIN) format. The TIN structure is better suited for topographic data analysis and is mostly offered as a separate option in various GIS packages. The grid and vector structures are usually used in the planning analysis fields (Dueker, 1987).

The grid structure utilizes a rectangular array to define a polygon framework for storing geographic information (Figure 1). The grid acts

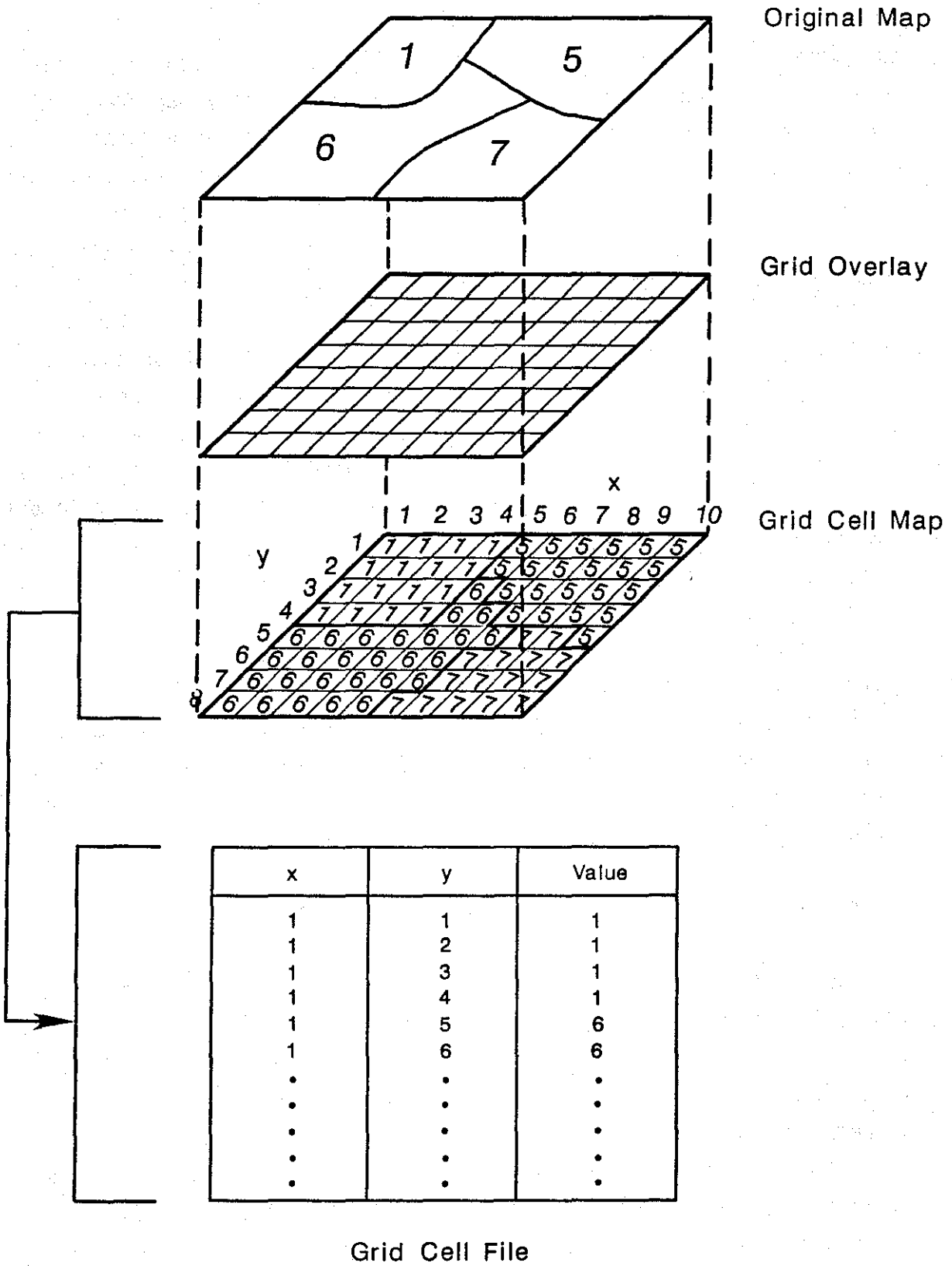

Figure 1. The Grid Format for Structuring a Geographic Data Base (Dangermond, 1983).

as a matrix of x,y coordinates to represent changes in geography. The advantages of such a system are apparent when performing map overlays, since it can be performed without prior processing, or when using satellite digital imaging or scanned aerial photographs as means of data input. Disadvantages include a slowing in display time directly proportional with map resolution, and an inherent inability to explicitly represent feature boundaries (Stiefel, 1987).

Data in a vector format geographic data base can be structured topologically, facilitating the storage and retrieval of geographic data and the recording of spatial relationships of geographic features. Figure 2 illustrates how topological relationships and node coordinates are used in the representation of a polygon network. Since vector-based GIS uses lines to represent geographic features, their resolution is only limited by the resolution of output devices. However, this same quality also poses some disadvantages; map overlaying involves determining areas of overlap between base and overlay map elements by comparing polygon areas and determining points of intersection. The time taken for this operation is a function of map complexity and CPU processing speed and can be quite lengthy. Also, scanned photographs and satellite images have to be converted to vector format before they can be analyzed by a vector-based system. This is usually done manually using a digitizing tablet and is a labor-intensive and time consuming process.

The Attribute Data Base

Attribute data refers to all descriptive non-geographic information (variables, names, and characteristics) that identify a geographic feature. For instance, an artificial lake can be identified by its name, water level, water quality, chemical composition, salinity, water temperature, alligator population, bottom soil type, ownership, etc.

All GIS's use some kind of data base management system (DBMS) to facilitate the handling of attribute data. DBMS's integrate tools for formatted data entry, data editing, data processing and manipulation, data query, and report generation.

DBMS's can be hierarchical or relational depending on the data base model used. In a hierarchical DBMS, attribute data is organized using a

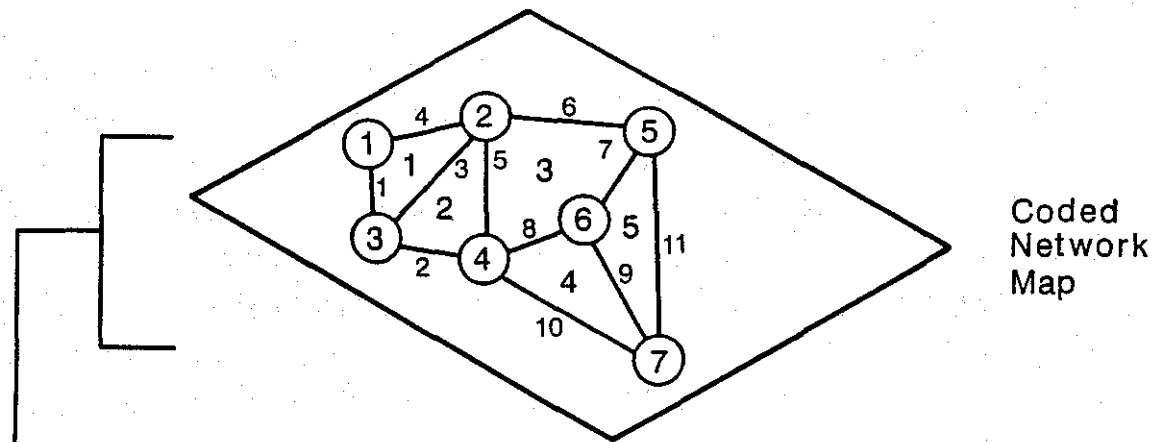

Coded Network Map

Link #	Right Polygon	Left Polygon	Node 1	Node 2
1	1	0	3	1
2	2	0	4	3
3	2	1	3	2
4	1	0	1	2
5	3	2	4	2
6	3	0	2	5
7	5	3	5	6
8	4	3	6	4
9	5	4	7	6
10	4	0	7	4
11	0	5	5	7

Topologically Coded Network & Polygon File

Node #	X Coordinate	Y Coordinate
1	23	8
2	17	17
3	29	15
4	26	21
5	8	26
6	22	30
7	24	38

X, Y Coordinate Node File

Figure 2. Representation of Polygon Network Through Topological Relationships and Node Coordinates (Dangermond, 1983).

hierarchical data structure where all information related to a geographic feature is linked together by pointers stored in the data record (Stiefel, 1987). This structure allows for fast information retrieval and is useful in applications where a rigid data structure is desirable. In a relational structured DBMS all feature information is kept in tables where the relationships between entities is maintained by indexes that point to data fields. Related data associations are formed according to specific data interrelationships. The relational approach, although slower in information retrieval than its hierarchical counterpart, offers a more flexible data structure. This quality is important in applications where the user needs to define new relationships between data fields which in turn will result in the creation of a new attribute.

The Georelational Data Structure

One of the main functions of a GIS is to establish the relationship between the location of features in the geographic data base and their corresponding descriptions in the attribute data base. A GIS performs the linkage between locational and attribute data by means of a georelational data structure. A georelational data structure is a hybrid data model that represents locational data in a topological model and represents attribute data in a relational model (Morehouse, 1985). In order to establish a georelational structure, a one-to-one relationship must exist between the record of an entity in the locational data base and the record of that entity's descriptive data in the attribute data base. It is this link between geographic and attribute data that allows a user to map all roadway sections with serviceability indices greater than 3.5, for example (Dueker, 1987).

REVIEW OF GIS-RELATED ACTIVITIES IN TRANSPORTATION

Although applications of GIS have traditionally been outside the transportation area, the technology is rapidly emerging as the information management tool of the future for transportation agencies. Already, there are on-going projects within several agencies that are directly related to the development and implementation of geographic

information systems. In this section, we present a review of GIS-related activities within several transportation agencies in the United States.

North Carolina Department of Transportation

A GIS feasibility study has been completed by the Division of Highways of the North Carolina DOT (Dildine et al., 1988). Three major areas of application of a GIS were identified as follows:

1. Map publishing - a GIS provides a way of automating the production of a variety of maps used within the Department. These include county maintenance maps, straight line maps, urban planning maps, and Transportation Improvement Program (TIP) maps.
2. Management/modeling activities - a GIS can function as a data analysis tool to support the programming of roadway projects (e.g. maintenance, rehabilitation, and safety improvement projects), and the justification of funding requests.
3. Ad-hoc queries - a GIS can be used to perform "what if" analyses on the highway network and can show the effects of different "what if" scenarios in a way that the user can readily grasp and comprehend, i.e., through pictures.

The feasibility study was conducted by a GIS Task Force within the Division of Highways who has determined that a GIS is feasible and should be actively pursued by the Department. The Task Force has developed a plan for implementing a GIS that calls for the creation of an Implementation Committee and a staged approach to GIS implementation. Initial efforts will be to develop a GIS for users in the major areas of pavement management, traffic engineering, planning, bridge maintenance, map publishing, and field office support. The initial cartographic data base will be developed from 1:100,000-scale USGS DLG's to allow the GIS to be operational within a reasonable length of time. However, the implementation plan also calls for the development of a 1:24,000-scale digital cartographic data base that will serve a broader range of users. The informational data base design is also going to be established in the

initial phase of the implementation plan. IBM's relational data base DB2 has been recommended by the GIS Task Force as the informational data base management system to use with the GIS.

In addition, the development of user interfaces and application programs will be accomplished in the initial stage. As these programs are developed and brought on-line, the Implementation Committee will provide support to users in the initially targeted application areas to help them get started on using the GIS. This will be accomplished in Phase 2 of the implementation plan.

In Phase 3, expansion of the GIS to serve other users within the Department is planned. The Task Force anticipates that as the GIS becomes fully functional, personnel from other branches of the Department (e.g., Policy and Programs, Maintenance, Construction, and Design) will become heavy users of the technology. At this point, the Task Force realizes that a careful evaluation of user needs in these other areas will be necessary so that application programs can be developed accordingly.

Development of the 1:24,000-scale digital land base is also scheduled to begin in Phase 3 of the implementation plan. Currently, 1:24,000-scale DLG's are not available for the entire State so the implementation plan also calls for the study of methods for developing and updating the digitized land base in a GIS. In addition, the plan calls for evaluating the application of photo-logging and laser disc technology within a GIS.

Ohio Department of Transportation

The Ohio DOT began developing a GIS back in 1980 with initial funding from the National Highway and Traffic Safety Institute. Consequently, the primary application of GIS has been in the analysis and reporting of accident data. The GIS is based on INTERGRAPH hardware and software. Data is stored in the Department's IBM mainframe computer and an interface allows access of the data by the GIS. INTERGRAPH's Data Management and Retrieval System (DMRS) is used for data base management, and its Spatial Analyst software is used to query, analyze, and display the geographic data base. This data base includes 112,000 miles of

roadways and was developed by manual digitization (Bacon and Moyer, 1989).

Ohio has made considerable use of GIS in planning and operations, and sees its greatest potential as being in the support of the decision-making process.

New Mexico Department of Transportation

The New Mexico Department of Transportation is currently developing a statewide network of geodetic monuments which will be used to locate positions within the State using GPS technology. The Department sees GPS as being necessary to support the long-term implementation of a GIS. Although initial GIS implementation will be based on the 1:100,000-scale Census TIGER files, the ultimate goal of the Department is to have a highly accurate, large-scale land base for its GIS. This land base will be developed and maintained through GPS.

GIS implementation is currently getting underway with the immediate objectives being to define the system requirements and to subsequently develop a request for proposals to commercial vendors. With respect to issues on GIS implementation, the following were identified by the Department as being crucial to the successful implementation of a GIS:

1. Location referencing scheme - although the Department has already developed a common referencing scheme for its GIS, the process was not without any difficulties. Consequently, the New Mexico DOT sees the development and implementation of a unified location referencing scheme as being an important issue to address. Guidelines that will help make this task much easier are needed.
2. Data standards - the Department believes in encouraging the use of data standards to facilitate information exchange. In particular, standards for digital cartographic data are important.

Pennsylvania Department of Transportation

Pennsylvania has already spent \$1.7 million for GIS implementation (Bacon and Moyer, 1989). The state DOT has already digitized 42,000 miles of highways, with another 3 to 5 more years estimated before the digitization efforts are completed. High on the list of Department priorities is the restructuring of position-related data. With so many data bases, Penn DOT relies heavily on a fully functional, network-structured data base design. It is expected that the combination of graphic and tabular data to support planning and decision-making activities will push the technology rapidly forward in the near future.

Colorado Department of Highways

The Colorado Department of Highways (CDOH) is in the third year of its initial GIS plan which covers three major areas (CDOH, 1989):

1. System acquisition
2. Data base development
3. GIS accessibility

The system acquisition phase has been completed with the purchase, in 1986, of the ARC/INFO software from Environmental System's Research Institute (ESRI). Data base development is currently on-going and is scheduled for completion in 1992. In order to facilitate the development of the geographic data base, existing USGS 7.5-minute quadrangle maps for the entire State were purchased by the Department from the Petroleum Information Corporation. Considerable enhancement to the highway layers of the digitized maps is currently being done by the Colorado DOH.

To date, 7 of the 56 counties in the State have been digitized and linked to the Department's statistical data bases. A route-milepost reference system is used to link the geographic data base to the CDOH data bases, the main one being the Colorado Roadway Information System (CORIS). Data base development efforts are expected to lead to an integrated data base with over 100 attributes per roadway segment. The geographic data base will contain approximately 160,000 separate line

segments, representing 9200 miles of state highways, and 67,600 miles of county roads and streets.

Already, certain benefits have been realized in the implementation of the GIS. The most noticeable benefits are in the reduction of the time required to produce map overlays and update existing maps, and in the elimination of redundant base maps. In particular, the map overlay function was very useful in the designation of routes for the Hazardous Material Route Designation program. In this application, census data were overlaid with the highway network in order to produce population estimates for the routing model.

Other on-going GIS activities within the Colorado DOH include:

1. Implementation of the Department's computer network which will provide users access to the GIS and to any other data in the Department.
2. Evaluation of GPS to increase network of survey control points and produce more accurate maps.
3. Evaluation of the needs of CDOH engineers to determine if a project level GIS component is feasible.
4. Acquisition of new non-highway related information such as demographics, political district boundaries, soil types, land use classifications, and contours to increase modeling capabilities.

The Department plans to undertake an intensive effort during the next three years to complete the geographic data base. This will be accomplished using commercial vendors to help in the digitizing efforts. The Department also intends to continue actively promoting cooperation with Federal, State, and local agencies by sharing information and thus avoid duplication of efforts.

Wisconsin

The Wisconsin DOT has a long history of automation development. Like other pioneers, this has its positive and negative aspects. The negative aspects are related to the propagation of numerous systems

developed at different times using different technologies which are not compatible with one another. Like other states, their accident system is not compatible with the roadway inventory which is not compatible with pavement condition and so on.

However, with the development of a completely digital state highway map for their 12,000 mile road network, the Wisconsin DOT views GIS as a possible data base integrator. They are using ARC/INFO software to systematically examine GIS applications into:

- a) the integration of photolog data into GIS (Fletcher, 1988) and
- b) the integration of other highway attribute data into a GIS using a line overlay approach. Separate files will continue to be maintained by different units within the DOT. It is the job of GIS to use topologically structured cartographic chains to perform the integration.

Kansas

The Kansas DOT is actively trying to expand the capability of the FHWA sponsored GRIDS system. As originally configured, the GRIDS package was optimized to analyze the HPMS data for each state. Efforts in Kansas are focussed on adding bridges to the system so that information stored in the Federal Bridge Management System can be graphically displayed.

The Kansas effort should permit graphical displays of deficient bridges to supplement the deficient highway identification routes available with the original GRIDS package.

California

Like Kansas, the California DOT was equally impressed with the potential of the GRIDS package. The California efforts have focussed on expanding the network. The original GRIDS package only contained routes on the primary network. However, the HPMS package contains information on secondary systems such as minor arterials and collectors. California has digitized its entire highway network and now can graphically display,

via the GRIDS software, every highway for which it is responsible.

Alaska

The Alaska DOT is currently integrating its highway related data bases (inventory, condition, traffic, accidents and project history) into a Highway Analysis System (HAS) (Nyerges, 1988). This system contains a topological segment/node representation of the physical roadway network. Attribute data is referenced according to a relative distance from the beginning node. Maps are being digitized and digital data is being acquired from USGS to provide coordinates for highway geometry.

This work is being performed under contract with Boeing Computer Services.

GIS-Related Activities at the Federal Level

In addition to the preceding GIS activities at the state level, there are similar activities on-going at the Federal level. This section presents the Federal Highway Administration's (FHWA) and the American Association of State Highway and Transportation Officials' (AASHTO) ongoing efforts aimed at developing applications of GIS technology in the transportation realm.

Federal Highway Administration.

The FHWA has sponsored the development of a software package called GRIDS which it is actively disseminating throughout the 50 state DOT's. GRIDS, an acronym for Geographic Roadway Information Display System, is a microcomputer-based software package that allows its user to access and display data pertaining to the U.S. Interstate Highway System. GRIDS was developed by the Caliper Corporation of Newton, Massachusetts under the sponsorship of the Federal Highway Administration's Office of Planning and Pennsylvania State University.

GRIDS displays a map of a state (maps for the forty-eight contiguous states are available) from data associated with state and county borders, geographic location and population of major cities, and interstate

highway road sections. A user, by means of an interactive type interface, can request GRIDS to zoom-in to a particular area of the state and to display information concerning the interstate highways within the area in question.

GRIDS integrates many analytical and data query capabilities that are used with its attribute data base (a subset of the HPMS data) to produce statistical summaries and pie and bar graphs of selected data. The data query capability is also used to select specific sections of interstate highways that meet certain criteria. Then, the selected sections can be highlighted in distinctive colors directly on the map display. Also, the system can be asked to display the value of any attribute (AADT, serviceability index, skid) on the map, next to its corresponding section. Section traffic volumes can be displayed over the highway map by proportionally varying band widths.

The land base map used for GRIDS is based on the Oak Ridge National Laboratories (ORNL) 1:2,000,000 scale National Highway Network. In order to simplify manipulation, the network has been divided into state sub-networks. Each sub-network is made of various files containing both geographic and attribute information. The attribute data base used in GRIDS is a subset of the data contained in the Highway Performance Monitoring System (HPMS) data base (Simkowitz, 1989), which is maintained and updated by the FHWA on a yearly basis, and is made from data submitted by each of the 48 contiguous states. In this detailed and extensive data base, interstate highways are divided into sections. Section lengths vary widely from state to state. Each section together with its associated attribute data constitutes a record in the data base. Sections are classified into universe and sample. Universe sections contain only vital information such as road number, average daily traffic, etc, while sample sections contain more detailed information such as road curvature and grade data (Peterson and Smyre, 1984).

The GRIDS package was primarily developed to display roadway information for interstate highways found in the HPMS data base. It is useful for graphically displaying information accessed within the confines of its data base. However, program modifications are necessary to enable a transportation agency to use its own data base and to display roadway information on non-interstate highways.

In addition to the above limitation, the current version of the program does not have any capability for editing the data base. The HPMS data base files are centrally managed by the FHWA which provides state transportation agencies with copies of the GRIDS package, including the HPMS files applicable to a particular state. Thus, further program modifications are needed to add editing capability to the program. Ideally, these modifications and other revisions to the program should be carried out by the transportation agencies themselves, as an in-house effort. However, all program modifications will most likely be made by Caliper Corporation since they own the copyright to the software.

The FHWA Office of Planning has also joined forces with the Bureau of Census, the U.S. Geological Survey, the city of Columbia, Missouri, and the Caliper Corporation to evaluate the suitability of the Bureau of Census TIGER/Line files to transportation applications. The TransCAD GIS package developed by Caliper Corporation, was used for the study together with the following sources of data: TIGER/Line file for Boone county (Missouri); the Urban Transportation Planning Package (UTPP); 1980 Census Data; and accident records and sign inventory provided by the Columbia Department of Public Works. Several GIS applications to transportation were demonstrated:

- The ability to build connected transportation networks from TIGER/Line files
- Routing and traffic assignment performed on the transportation network
- Demographics studies within census tracts and traffic analysis zones
- Accident analysis studies based on spatial relationships between accident locations and traffic signs

These applications demonstrated the usefulness of the TIGER/Line file for solving transportation problems within a GIS environment (Simkowitz, 1989).

American Association of State Highway and Transportation Officials.

The American Association of State Highway and Transportation Officials (AASHTO) has recently sponsored a symposium on Geographic Information Systems for Transportation. The symposium was organized for the following purposes (Bacon and Moyer, 1989):

1. To share information on current operational Geographic Information Systems in several transportation agencies in the United States and Canada.
2. To identify specific GIS applications in transportation.
3. To provide technical material on GIS to better the understanding of this technology within the transportation community.
4. To determine the perceived needs and expectations of high-level transportation executives on GIS.
5. To develop an action plan to guide further activities on GIS in the transportation area.

Numerous applications of GIS to transportation were identified during the symposium including:

1. Infrastructure management
2. Scheduling of projects
3. Improvement of highway safety
4. Environmental impact assessment of existing and new facilities
5. Travel demand modeling
6. Vehicle routing

An important conclusion reached during the conference is that the technology already exists to allow transportation agencies to begin implementing geographic information systems. The key question to answer is HOW to implement a GIS. In this regard, a number of issues were identified in the areas of Applications, Management, Data Needs and Acquisition, and Technology which the symposium attendees felt were critical to the successful implementation of a GIS.

The issues raised also formed the basis for the development of an action plan to guide GIS activities in the field of transportation. This plan consisted of five major items:

1. Education - a strong case was made for educating and training the transportation community on GIS.
2. Standards - there is a need to develop standards in several areas to facilitate data sharing.
3. Institutional impacts - as with the implementation of any new technology, the potential impacts of GIS to transportation agencies need to be defined.
4. Networking - information on GIS activities should be made available through some kind of a network.
5. User requirements - certain transportation applications of GIS may be unique and significantly different from traditional GIS applications (e.g., natural resources management, automated mapping, facilities management). Thus, there is a need to identify specific user requirements within the transportation community and to communicate these to vendors of GIS products so that transportation requirements can be better met.

3. ISSUES IN GIS DEVELOPMENT AND IMPLEMENTATION

Transportation agencies planning to develop and implement geographic information systems are faced with important issues requiring difficult and perhaps agonizing decisions. It is important to recognize these issues early on since the successful implementation of a GIS depends, to a great extent, on how adequately the issues are addressed and resolved. In this chapter, attention is given to GIS development and implementation issues in order to provide the Texas SDHPT with an overview of the kinds of decisions that will have to be made in order to implement a Department-wide GIS. It is important to give detailed consideration to the issues presented, rather than focusing attention primarily on hardware and software. Even the best GIS hardware and software is only a tool, not a solution in itself, which needs careful thought in implementation.

To emphasize the above point, the following section is quoted from a report summarizing the recent AASHTO specialty conference on GIS (Bacon and Moyer, 1989) in Orlando, Florida:

"The question most often asked is what is the best way to implement a GIS in my organization. In this regard, a number of specific questions related to application issues, management issues, data issues, and technology issues were identified:

Application Issues

- How do I start?
- What scale maps should be used?
- How do I coordinate with others?
- What area do I implement first (pavement management, bridge management, safety, road inventory)?
- How do I interface with my existing data bases?

Management Issues

- How do I get top level support for the resources needed?

- Who should have the lead for GIS within my organization?
- What will it cost?
- What is the best way to get started with GIS?
- How do I prepare a GIS plan?
- How do I educate my organization about GIS?

Data Needs and Acquisition Issues

- What digitized data is already available?
- What scale map should I use?
- How do I put together digital data with attribute data?
- How do I obtain latitude/longitude for existing data?
- How do I keep the data up-to-date?

Technology Issues

- What GIS system should I use?
- Should it be mainframe, mini or micro?
- How do I interface with our existing data bases and CADD systems?

The conclusion in this section was that it is not IF to implement a GIS, but rather HOW to implement a GIS. The technology already exists to do the job. The key is obtaining answers to the issues raised above, which in turn depends on getting educated on all facets of GIS in order to effectively implement a GIS in the organization."

The above important issues arise from three basic questions that are relevant to all development efforts, namely:

1. Where are we now?
2. Where do we want to go?
3. How are we going to get there?

The above questions seek to establish the current environment so as to develop a point of reference for identifying where changes are

necessary, what capabilities can be carried over from the current environment to the new, and what impacts would occur if the current environment was changed. The impacts brought about by change are sometimes difficult to handle. To illustrate, a transportation agency seeking to develop and implement a GIS will more than likely have information systems and data bases already in place. Thorough decisions must be made concerning what portions of the existing data system are scrapped, what portions are converted into a new format, and what portions are left unchanged. A good GIS will allow a transportation agency to build upon what it already has. However, this is not to say that existing systems can simply be interfaced with a GIS, without any changes being made.

To explain further, it is known that some form of geographic referencing is required in a GIS. However, a transportation agency will usually find that existing data on the highway network are not referenced geographically. Moreover, it is perhaps not uncommon to find a variety of referencing schemes being used for the various data bases that exist within the Department! This situation brings with it a host of questions for which answers may not be easy to find. These questions include:

- Do we convert to a single referencing system?
- If we decide to develop a unified referencing scheme, how are we going to develop one?
- How long would it take to develop a unified referencing scheme and is the time involved acceptable?
- How do we implement the unified referencing scheme?

The development of a unified referencing scheme is advantageous from the viewpoint of establishing uniformity in the way data are referenced and in completely tying together all the data within a particular agency. However, its development may be a long, arduous process. Oftentimes, it is difficult to build a consensus among a variety of groups with a diversity of needs. Still a transportation agency may decide to go ahead and develop a unified referencing scheme because it believes that, in the long term, it is best to have one.

Another aspect of this issue is to allow the existence of multiple

referencing schemes in various layers of the GIS provided that a common geographic coordinate system is used to tie together all these layers. This alternative may be easier to implement but the multiple referencing schemes will always exist. Although the common geographic coordinate system will allow various groups to exchange information on the highway network, within a particular group, data will be referred using the same scheme that has always been used in the years past. Thus, this alternative may be good only as a short term solution, and a better alternative may be to combine it with a development plan for a unified referencing scheme. The multiple referencing schemes will be used only until a unified scheme is developed. In this way, the transition to GIS is made as smooth as possible.

Other issues that transportation agencies will have to resolve in developing a GIS arise from the diversity of user requirements characteristic of almost all agencies. Within any transportation agency, one will find planners, pavement managers, and district engineers who make decisions at the network level. However, there are also pavement design and geometric design engineers, at the other end of the spectrum, who concern themselves with very specific projects. Within this wide range of users, one can expect the data requirements to also vary widely.

In this situation, one issue that is important to address is the accuracy to build into the digital spatial data base of the GIS. People who make decisions on a network level are not going to require as much accuracy as those concerned with the engineering design of very specific projects. For example, people who are responsible for developing schedules of maintenance, rehabilitation, safety improvement, and widening projects are probably going to be satisfied with 50 to 100 foot accuracies. On the other hand, those who will be engaged in the actual engineering design of scheduled projects may require 1 to 5 foot accuracies, and very large-scale digitized maps.

To some, the answer to the question of what accuracy to strive for may be deceptively simple - just strive for the highest accuracy that will be required based on the survey of user needs. However, the issue is really much more complicated. For one thing, an agency should ask itself how much accuracy it can afford. A highly accurate, large-scale digitized land base can be very costly and time consuming to develop.

Assuming that a transportation agency has the money to build this kind of digitized land base, the development time will be so long that interest in the GIS project will be very hard to sustain. For another thing, not all users will require the high accuracy. More than likely, there will be groups who can use already existing digital spatial data bases, such as those developed by the USGS and the Bureau of Census, to get started on implementing a GIS and realizing its benefits. Very careful consideration must be given to developing an implementation schedule for a GIS. This schedule must cover both short-term and long-term goals. A possible short-term goal is to bring the benefits of the technology as quickly as possible to those groups of users who do not require too much accuracy. A long-term goal might be the development of a highly accurate, large-scale land base with the idea that initially developed land bases of lesser accuracy will gradually be phased out as portions of the highly accurate land base start coming on-line.

Another item that must be considered in the development of an implementation schedule is the maintenance of the digital land base. Highway segments change and provisions must be made for updating the land base. Depending on the accuracy of the land base, a transportation agency may find that it has to develop new capabilities to maintain the land base. For example, supporting a highly accurate, large-scale land base may require the application of Global Positioning Systems (GPS) technology.

Still another item to consider in developing and implementing a GIS is the identification of the specific types of data that various users work with. More than likely, this will cover a wide range. Those who are responsible for programming of projects, for example, will require data on the condition of pavement sections in the highway network, the traffic volume on specific lengths or corridors of the network, and accident data, to name a few. Those who are responsible for designing specific projects will require data on thicknesses of various pavement layers, material properties of each pavement layer, the existing traffic on a specific project, and topographic data. The types of data are important to consider in developing the structure of the data base for the GIS. In addition, when evaluating the types of data to include in the GIS data base, a transportation agency would be wise to ask itself

the following questions:

- What types of data do we really need and what benefits are obtained from having the data?
- What does it take to get information on each data type?
- How much data collection can we afford?
- What new capabilities must we develop to facilitate data collection?

Obviously, the kinds of data to include in the GIS data base will also depend to a great extent on whether the agency can afford to be collecting the data on a regular basis. For example, pavement layer thicknesses are examples of data items that pavement design engineers will have a strong need for. However, maintaining data on layer thicknesses is difficult and can be very costly. Consequently, there may be a need to identify research and development efforts in the area of data collection techniques that could lead to better methods for collecting data and thus facilitate the maintenance of the GIS data base.

It can therefore be seen that there are a variety of issues in GIS development and implementation that would require careful and thoughtful deliberation on the part of transportation agencies. An attempt has been made herein to identify some of the issues which may be potential stumbling blocks in the development and implementation of GIS technology. Alternatives for resolving these issues have been identified, but it should be emphasized that the solutions raised may not necessarily be appropriate for the Texas Highway Department nor will the solutions be the same from one agency to another. This of course just underscores the importance of giving careful consideration to the issues raised vis-a-vis the objectives of a particular transportation agency.

4. DEVELOPING THE GEOGRAPHIC DATA BASE FOR A GIS

As discussed in an earlier section of this report, one of the two major elements of a GIS is the geographic data base or land base. The development of this GIS element is a major undertaking and involves the transformation of map features from analog to digital form. To a trained human observer, the various features found on a map such as roadways, rivers, forest stands, and soil types are readily identifiable. However, in order for a computer to distinguish between various map features, the data needs to be reduced to the computer's level of comprehension.

The process of transforming map features into a form the computer can use is referred to herein as data capture. More specifically, data capture involves the conversion of map features from analog to digital form. In this chapter, various methods of capturing data are presented. In addition, sources of digital cartographic data for developing the land base are identified. It is recognized that, depending on the user requirements, available digital cartographic data can greatly facilitate the development of the land base for a GIS. Important considerations in developing the land base are also discussed vis-a-vis the user requirements identified during the study and an assessment is made of the capabilities of the Texas SDHPT to develop and maintain the land base for a GIS.

METHODS OF DATA CAPTURE

The transformation of map features from analog to digital form is perhaps the most time consuming and expensive task in the development of a GIS. The objective of this task is to produce computer-compatible digital files that satisfy accuracy requirements specified by the user and contain spatial and topological information on the map features of interest. A significant amount of pre-processing and post-processing is usually involved in digitizing cartographic documents to ensure that clean and usable digital files are produced. In this section, methods to generate digitized maps for GIS applications are reviewed.

Manual Digitization

Manual digitization is usually done with a graphics digitizer. In this method, maps are digitized by an operator who moves a cursor along individual map features and defines points associated with those features. Depending on software, it may be possible for an operator to attach attributes to map features, and specify topological relationships between features at the time digitization is being conducted.

The most common digitizer is the transmitter/receiver type, with the cursor transmitting a low level electrical charge and the tablet sensing its location. The digitizing tablet has an imbedded wire mesh that is electrically charged. The intersections of wires running in the vertical and horizontal directions form a series of addressable coordinates with the lower left corner having the coordinates (0,0). Tablet resolutions vary, but typically, tablets with 1,000,000 addressable coordinates per square inch are available. Sizes also range from 11" x 11" to 48" x 64", and tablets with backlighted surfaces are also available for digitizing maps on a transparent medium such as mylar-based film.

Manual digitization is most appropriate when the volume of data to be digitized is small or where labor costs are inexpensive. The data volume will of course be dependent on the user defined requirements for a GIS. These include the required accuracy of the digitized maps, the types of features that must be encoded, and the resolution specified for each map feature. Obviously, as the data volume increases, the cost of manual digitization may become very prohibitive. In this situation, alternative procedures that allow for the automatic or mass digitization of maps become more feasible. These procedures are presented in the following.

Automatic or Mass Data Capture

Automatic or mass data capture typically involves generating a raster image of a map and subsequently converting the raster image to a vector format. The raster image is produced by scanning a map row by row using a raster digitizer or scanner. The most common scanner used in digital cartography is the drum scanner.

Figure 3 provides a schematic illustration of the drum scanner. The

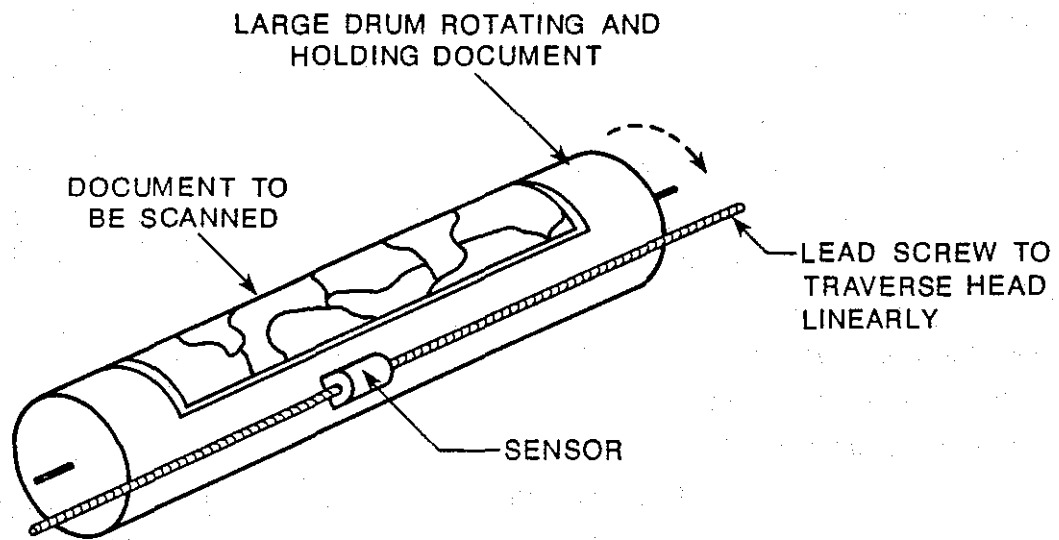

Figure 3. Schematic Illustration of a Drum Scanner (Peuquet and Boyle, 1984).

map to be scanned is fitted onto the surface of a drum as shown in Figure 3. As the drum rotates, it is viewed by a finely focused photo-detector attached to a helical drive which moves the detector linearly across the surface of the drum parallel to its axis of rotation (Peuquet and Boyle, 1984). The head records reflected light as it moves across the source document providing a means of recognizing any features depicted on the map. The scan line width can be adjusted over a useful range so that various degrees of resolution are attainable. However, finer resolutions lead to longer scan times.

Examples of drum scanners are those manufactured by Scitex and Optronics. Scitex scanners are used by the United States Geological Survey in the production of digital line graphs. The Scitex RESPONSE 250 scanner accepts documents up to 36" x 36" in size. The normal scanning speed at 0.001-inch resolution for this scanner is reported to be 130 lines per minute (Peuquet and Boyle, 1984). However, faster scan times are attainable at coarser resolutions (e.g., 0.008" or 0.002"). With most drum scanners, scan times vary typically from 20 to 90 minutes and resolutions range from 0.001" to 0.004".

An important point to remember when considering the use of raster digitizers is that every point on the source document that is detected is recorded. Thus, highway names, airport symbols, railroad lines, contour elevations, and political boundaries (to name a few) are all recorded. It takes subsequent computer processing to distinguish between the various features and to add structure to the data by separating various feature types and symbols into different layers. Within a GIS, cartographic data is usually separated into various layers or coverages that are all tied together through a single referencing system (Figure 4).

The amount of editing that is required after maps are scanned may be too costly so as to render mass data capture a less attractive alternative than manual digitization. However, the amount of editing that would be required after scanning can be minimized by using map separates in lieu of the composite map. Map sheets are commonly made from a series of color separations that correspond to various thematic features. For example, hydrographic features are normally contained on a "blue line" plate. The plates are of course in black and white and the colors are just added in the map production process. Use of map separates that are normally

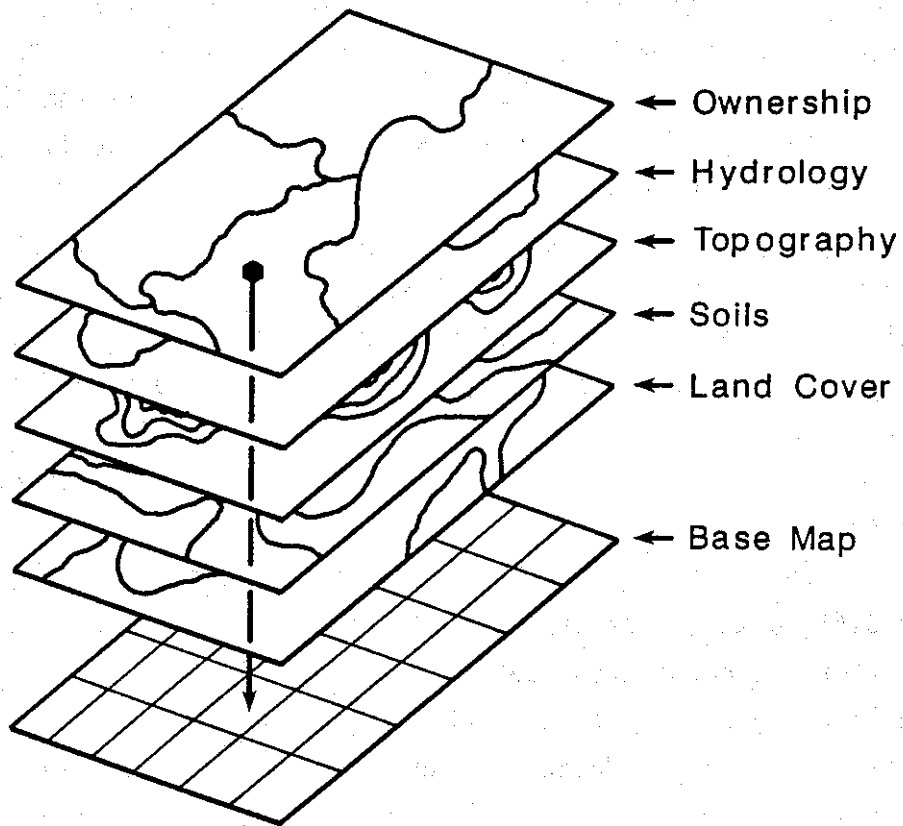

Figure 4. Schematic Illustration of Map Layers or Coverages in a GIS.

available from the U. S. Geological Survey can greatly facilitate the structuring of scanned data.

In addition, re-scribing of the original map document into a form more suitable for scanning may be done especially when editing costs are such that re-scribing can be justified. For example, modified contour maps may be prepared prior to scanning where the contour lines are of uniform line weights and are without the usual breaks associated with the placement of contour elevations. The use of uniform line weights and the absence of breaks and the associated numeric values can greatly facilitate the automated interpretation of scanned data later.

The interpretation of an array of dots in a raster image to identify map features that are present involves the application of pattern recognition techniques. Significant strides have been made in recent years in using template matching and statistical methodology to analyze and identify pixel clusters (Skiles, 1988). This makes it possible to recognize and extract textural and symbolic information directly from the raster image data.

Template matching compares a sample pixel pattern or template, from a user defined knowledge base, with pixel clusters in the raster image. The greater the correlation between the template and a pixel cluster, the greater the probability that a match has been found. With the statistical recognition technique, detached pixel clusters are identified from the raster image. A statistical model for each pixel cluster is then prepared based upon physical characteristics. This model is subsequently compared with models in a user defined knowledge base and the probable identity of the pixel cluster determined. Based upon the degree of certainty in the identification, the feature is then recorded into the data base or presented to the user for manual verification.

In contrast to template matching, statistical recognition is relatively more tolerant of the variability in cartographic features. With the former technique, pixel clusters are compared to a template which, by nature, is fixed. Thus, highly variable features such as handwritten text or symbols may not be reliably recognized. For these cases, statistical recognition may be a more viable alternative for the interpretation of scanned data. However, one should remember that with this method, target clusters must be identified and detached from the raster image.

Consequently, a significant amount of editing may be required before interpretation can be achieved.

The interpretation and structuring of raster data are major tasks that are conducted after scanning operations have been completed. Certain GIS applications can be implemented once the interpretation and structuring of raster data has been achieved. An example would be the identification of land areas that satisfy certain criteria related to land use, soil type, slope, and floodplain location. In this instance, the analysis may involve overlaying of raster data residing in the pertinent land use, soils, slopes and floodplain coverages. However, there are GIS applications, such as network analysis, that are inherently vector oriented. For these applications, the conversion of raster data to vector form will be necessary. Consequently, depending on user requirements, raster-to-vector conversion may have to be conducted after scanning operations have been completed.

Peuquet and Boyle present several methods for raster-to-vector conversion. A very recent development in this area is the VTRAK system introduced by Laser Scan Laboratories (Woodsford, 1988). VTRAK is an interactive system for raster-to-vector conversion that operates on a line-follower scheme. It is based on the Digital Equipment Micro VAX 11/GPX or VAX station 3000 series platforms.

VTRAK uses raster images from scanning operations as input. A raster image is displayed on a high resolution monitor and vectorization is conducted in either a semi-automatic or fully automatic mode. In the semi-automatic mode, the user selects a feature for raster-to-vector conversion by positioning the screen cursor close to the feature using a Mapstation console equipped with a trackerball and function keys. The function keys are used to give feature codes and control instructions.

The screen cursor follows the feature path, vectorizing the feature as it goes at high speed. The progress of the vectorization is indicated on the screen by a "digitizing trail." At points of ambiguity, user intervention is solicited to provide a resolution. This may occur, for example, when closely spaced contour lines are being vectorized. The user can intervene at any time to demarcate a feature or to prevent misinterpretation in areas of complexity or poor clarity.

The system can recognize dashed lines and gaps in lines such as

those where contour elevations are placed on topographic maps. Point features and junctions are automatically recognized and their locations determined. Feature coding is provided by the operator and is used by the system in conjunction with a Rules Table to generate optimal vector data and to minimize errors.

For source data with uncomplicated features, the fully-automatic data capture mode may be used. Referred to as the Autopass option in VTRAK, features are automatically located, followed, vectorized, and painted out upon completion of the conversion process. To minimize potential errors, the operator can define areas for which the Autopass option is to be implemented. Additionally, the Rules Table can be set up to reject all potential errors. All rejections that occur in the Autopass mode are routed to a guidance file for subsequent manual verification by the user.

In summary, VTRAK implements a raster-to-vector conversion methodology that is a hybrid of manual digitization and fully automatic, mass digitization. The burden of manually digitizing nodes, arcs, and polygons is lifted from the operator through the implementation of an automatic line follower scheme. The user is left with the responsibility of classifying and interpreting the data, in effect becoming the instrument for pattern recognition. Additionally, the user is responsible for structuring and validating the data.

Global Positioning System (GPS)

GPS involves the use of orbiting satellites to determine position on the earth's surface. There are two satellite systems available for this application at the present time. One is the TRANSIT system consisting of six satellites in more or less polar orbits at an altitude of approximately 500 miles (Merrell, 1983). The TRANSIT system was installed in the 1960's and is used by the U. S. Navy for navigational purposes. It is scheduled to be phased out in 1990 and replaced by the new satellite constellation referred to as the Global Positioning System. This system is scheduled to have 24 satellites in orbit by December 1991. All satellites in the GPS constellation will be in orbit at an altitude of approximately 12,500 miles.

Currently, seven satellites are in place, providing a measurement window of 5 to 6 hours within which survey data can be collected. This is accomplished using portable receivers to measure certain changes in the characteristics of the transmitted signal from a satellite. The characteristics that are measured are either the observed shift in the satellite transmitted frequency at the receiver site (i.e., the Doppler shift) or the phase angle of the satellite signal received. These measurements are used to compute the range vectors between the satellite and the receiver which are subsequently used with data on satellite position to determine location on the earth's surface. Information on satellite position at any given time (ephemeris data) is coded within the transmitted signal from the satellite.

The determination of geodetic positions of high accuracy is possible through GPS. Consequently, this technique is well suited for GIS applications requiring a high degree of accuracy from the digitized map data. Utility companies, for example, may have need for locating buried cables, gas lines, or electric utility poles to an accuracy of ± 5 feet. This need can certainly be met through GPS. The technology also offers a possible 6:1 increase in speed over hand digitization (Simkowitz, 1989).

SOURCES OF DIGITAL SPATIAL DATA

The preceding discussions have revealed the complex nature of converting map documents to digital form suitable for computer processing within a GIS. This is a time consuming and expensive task and it would certainly be advantageous if the digitization can be minimized or even eliminated outright through the use of available digital spatial data. Fortunately, an increasing number of digital cartographic data is becoming available, and GIS activities within the Federal government are expected to contribute to this growth.

Table 1 presents the results of a survey on GIS applications within various agencies of the Federal government. The survey was conducted by the Federal Interagency Coordinating Committee on Digital Cartography (FICCDC). This agency was established in 1983 to coordinate digital cartographic activities among various agencies of the U. S. government, and to promulgate standards and specifications for the production of digital

Table 1. GIS Applications Within Various Federal Agencies (FICCDC, 1988).

AGENCY	Response
Agency for Internat. Devel.	Famine and early warning, forestry, general natural resources management.
Central Intelligence Agency	Tool for research & development projects; soft-copy mapping and plotting; support to mobile missile analysts; agriculture, demographics, military, economics.
Customs Service	None at present, however, applications are being explored.
Dept. of Agriculture	
ASCS	
FS	Development, implementation, and monitoring of forest plans, support for local resource management projects; support for specialized projects, e.g. gypsy moth suppression, fire behavior modeling, high quality hardwood management.
NASS	Sampling frame development used for agricultural survey sampling.
SCS	Development of a soil survey geographic data base; soil survey interpretation maps for natural resource management; river basin and watershed project planning, farm and ranch conservation planning.
Dept. of Commerce	
Bureau of Standards	N/A
Census Bureau	All 1990 Census activities including but not limited to collection, control, mapping, geocoding and tabulation and publication of data.
NOAA/NESDIS	Production of atlases showing distribution of climatic variables (ice, drought, temperature precipitation, sunshine, length of growing season).
NOAA/NGDC	Use in construction of global data bases of thematic and geophysical data.
NOAA/NMFS	Multi-variant predictive models, e.g. spatial distribution of fish eggs and larvae.
NOAA/NOS	Ocean and coastal assessments-GIS supports the preparation of atlases and responses to ad hoc queries concerning spatial distribution of water currents, pollutants and living & mineral resources.
Dept. of Defense	
COE	Environmental planning, resource management, land-use management.
ETL	Automated terrain analysis research; feature extraction/terrain data base production and maintenance; development and evaluation of digital terrain data requirements; development of tactical decision aids and terrain data displays; imagery exploitation, AI research; environmental studies.
NORDA	Oceanographic sciences and terrain modeling.
USAF	Change detection, map and chart update and supplements, image graphics, perspective science study aids.

Table 1. (Continued).

AGENCY	Response
Dept. of Energy	
Bonneville Power	Environmental impact analysis for electrical transmission systems; resource inventory for facility siting, environmental protection.
Pacific Northwest Labs.	Analysis of multispectral remote sensing data, for energy and environmentally related uses.
Oak Ridge Lab.	Environmental monitoring and assessments, impact statements, regional modeling, transportation analysis, hazardous waste applications, regional siting terrain modeling, acid rain analysis, demographic studies, global climate studies.
Dept. of Health & Human Ser.	
Nat. Ctr. for Health Stat.	No specific applications at this time.
Dept. of Justice	
Drug Enforcement Adm.	
Dept. of the Interior	
BIA	Natural resources management; lease management; transportation network management.
BLM	Planning, inventory, monitoring, and management of lands, and mineral resources and renewable resources.
BM	Data collection, analysis and conversion.
BOR	Land classification, Reclamation Reform Act of 1982, irrigation monitoring, baseline habitat, engineering studies.
FWS	Refuge planning, habitat evaluation, National Wetlands Inventory, resources management.
NPS	Management of natural and cultural resources, prediction modeling, environmental assessments--many examples provided in survey.
OSMRE	Supports State regulatory authorities regulation of surface coal mines permitting and reclamation activities.
USGS	Nat'l mineral resource assessment, regional earthquake hazard assessment, national mapping program, national earthquake hazard reduction program. Nat'l water quality assessment program, strategic and critical minerals, offshore geologic framework, landslide hazards, volcano hazards, others.
Dept. of State	No specific program/applications at this time.
Envir. Protection Agency	Environmental assessment and management.
Federal Comm. Commission	Calculation of signed strengths; EEO Demographic analysis; prediction of radio propagation (future).

Table 1. (Continued).

AGENCY	Response
Fed. Emerg. Mgmt. Agency	Expects to use GIS as the principal data base management system for activities involving nat'l flood insurance program; nat'l shelter survey program, nat'l dam safety inventory, radiological emergency preparedness program, national civil preparedness program.
Fed. Energy Reg. Comm.	Ecological and engineering assessments in the development of Hydro Electric and Natural Gas Pipeline facilities.
Housing & Urban Devel.	
Interstate Commerce Comm.	
National Aeron. & Space Adm.	Primarily earth observations with some applications in the planetary programs.
National Archives	
National Capital Plan. Comm.	Project area planning.
Nuclear Regulatory Comm.	Geologic setting and engineering design evaluation of DOE site characterization and license application for high-level radioactive waste repository.
Postal Service	Development of program for interactive modeling of Postal Service delivery and collection routes.
Tennessee Valley Auth.	Management of TVA lands and reservoirs; site screening--industrial sites, generation, and transmission facilities; regional natural resource and economic development projects; monitoring of regional environmental conditions.
U.S. Information Agency	

cartographic data. The FICCDC is charged with facilitating the exchange of digital cartographic data and is an agency to refer to for determining what data is available, and where the data may be obtained.

In the following, several sources of digital cartographic data useful to the highway community are reviewed. As a reference, Table 2 has been prepared listing the addresses of agencies where digital spatial data may be obtained. It is advisable that any organization looking to develop a GIS investigate what data are presently available and evaluate whether the available data meet its requirements for a GIS.

U. S. Geological Survey (USGS)

The USGS has available to the public, digital cartographic data, broadly referred to as U. S. GeoData. U. S. GeoData include four main groups of cartographic data:

- 1) Digital Elevation Models (DEM's)
- 2) Digital Line Graphs (DLG's)
- 3) Land Use and Land Cover Data
- 4) Geographic Names Information

Of relevance to the highway community are the USGS DLG's which include planimetric data on two major features - hydrography and transportation. Transportation data consists of three sub-categories: 1) roads and trails; 2) railroads; and 3) pipelines, transmission lines and airports. The user need only purchase the digitized files that he or she needs. It is possible, for example, to get only the files containing roads and trails, leaving out the other sub-categories in transportation. Hydrographic data consists of flowing water, standing water, and wet lands.

USGS DLG's are available in small, intermediate, and large scales. All DLG's have a topologically structured format making them directly useful for spatial analysis in a GIS. The 1:2,000,000-scale DLG's are available for the entire United States. These are organized into 15 geographic sections for the conterminous 48 states, 5 sections for Alaska, and 1 for Hawaii for a total of 21 geographic sections. DLG's for 1:2,000,000-scale maps are sold by geographic sections. These DLG's were

Table 2. List of Agencies That Are Sources Of Digital Cartographic Data.

1. Federal Interagency Coordinating Committee
on Digital Cartography (FICCDC)
516 National Center
U. S. Geological Survey
Reston, Virginia 22092
2. National Cartographic Information Center
U. S. Geological Survey
507 National Center
Reston, Virginia 22092
3. Customer Service Branch
Data User Services Division
Bureau of the Census
Washington, D.C. 20233
4. U. S. Department of Agriculture
Soil Conservation Service
National Cartographic Center
P.O. Box 6567
Fort Worth, Texas 76115
5. Transportation Planning Division, File D-10
Texas SDHPT
P.O. Box 5051
Austin, Texas 78763

used in the development of the land base for the GRIDS package developed for the Federal Highway Administration by Pennsylvania State University and Caliper Corporation.

A 1:2,000,000-scale DLG is likely to be too small to be of considerable use to the highway community. However, the 1:100,000- and 1:24,000-scale DLG's can offer enough resolution for many practical applications. In a 1:100,000-scale map, an inch on the map is equivalent to 1.58 miles in the field which is comparable with the lengths of most Pavement Evaluation System (PES) sections in Texas, for example. The 1:100,000 DLG's are available for the continental United States and are sold in 30 x 30 minute blocks.

For even finer resolution, the 1:24,000-scale DLG's may be used. At this scale, an inch on the map is equivalent to 0.38 miles in the field. However, 1:24,000 DLG's are only available for certain areas. For Texas, the availability is very limited. Most DLG's for the state at this scale cover mainly Brown and Bexar counties.

Even though the DLG's may save the user time, effort, and money that would otherwise have been spent digitizing maps, there are still a number of operations the user must perform to use the DLG's within a GIS. First, the individual 30 x 30 minute blocks have to be edge matched which may involve a significant amount of editing. In addition, features must be identified and tagged with appropriate symbols and names to generate a visual display that is meaningful to the user. In certain cases, the feature codes that are part of the DLG's provide specific information as to the name of a particular feature. Roads, for example, will have their route numbers imbedded in the feature code. However, city names, street names, or names of hydrographic features are not included in the feature code and in many instances, specific feature names have to be determined by the user. The feature codes in the DLG's primarily provide information as to what a feature is (e.g., river, stream, navigable canal, interstate road, U. S. road), but do not provide specific names or labels except for route numbers.

In addition, certain highway applications may require that roadbeds of divided highways (or even individual lanes) be digitized so that specific information on pavement sections can be accessed and displayed. These applications would require mapping at scales much larger than those

used in generating the DLG files. In all of these files, roads are represented only by their center lines.

Finally, the user needs to link the attribute data in his/her data base with the DLG's. However, the attribute data may not necessarily be referenced in the same way as the DLG's, where locations are specified in latitude/longitude coordinates. Consequently, the user may have to do conversions on the attribute data to conform to the latitude/longitude referencing scheme.

Bureau of Census

In order to automate the support process for censuses and surveys, the U. S. Bureau of Census has undertaken to develop and implement a system that will produce computer generated maps, assign addresses to geographic units, and delineate geography for the collection, tabulation, and publication of census data (Sobel, 1986). This effort has resulted in the Topologically Integrated Geographic Encoding and Referencing (TIGER) System.

At the core of TIGER is a digital map data base developed from USGS 1:100,000-scale DLG's and the 1980 Census GBF/DIME Files. GBF/DIME stands for Geographic Base Files/Dual Independent Map Encoding. USGS 1:100,000-scale DLG's were used when no GBF/DIME files were available for a particular area. The DLG files were updated by the Census Bureau to include features that were non-existent at the time the DLG's were prepared. These features include recently constructed highways or railroads.

For major urban areas, GBF/DIME Files from the 1980 Census were available and were used to generate TIGER Files. As with the USGS DLG's, the GBF/DIME files were updated to reflect changes that have taken place since the 1980 Census. The files were also edited to remove topological errors, and extended to the nearest 7.5-minute quadrangle boundaries.

The GBF/DIME files and the USGS 1:100,000-scale DLG's were subsequently merged to form a seamless, nationwide data base from which county files are to be extracted. The generation of a seamless data base reduces the likelihood of getting adjacent files that do not match correctly. However, errors in edge matching have been found to materialize

when county files are extracted from the integrated data base. In most cases though, mis-matching along adjacent boundaries are not expected to occur.

Of particular interest to the transportation community is an extract from the TIGER data base known as the TIGER/Line File. This file includes digital data on political boundaries, statistical area boundaries such as tracts and blocks, and transportation features such as roads and railways. Prototypes of TIGER/Line Files for all counties of the United States are expected to be available by May or June of 1989. Updates to these files will be made from time to time by the Bureau of Census.

U. S. Soil Conservation Service

The U. S. Soil Conservation Service (SCS) is developing three soil geographic data bases to improve the storage, manipulation, and retrieval of soil map information (Reybold, 1988). These data bases are the Soil Survey Geographic Data Base (SSURGO), the State Soil Geographic Data Base (STATSGO), and the National Soil Geographic Data Base (NATSGO). Each data base represents a different scale of soil mapping. Components of map units of each data base are generally phases of soil series.

The SSURGO data base is primarily intended for use in county, parish, township, and watershed resource planning and management, and in farm and ranch conservation planning. Soil maps in the SSURGO data base are made from field observations and transects, and are prepared at scales ranging from 1:15,840 to 1:31,680. Detailed attribute information on soils will be compiled for the SSURGO data base. Examples of information that will be included are particle size distribution, bulk density, available water capacity, soil reaction, salinity, organic matter content and depth to bedrock.

STATSGO is intended primarily for river basin, multi-state, state, and multi-county resource planning, management, and monitoring. Soil maps for STATSGO are made by generalizing more detailed soil survey maps. The soil maps comply with national SCS guidelines and standards, and are made at a scale of 1:250,000.

NATSGO is intended primarily for use in national, regional, and state resource appraisal, planning, and monitoring. The boundaries of the

Major Land Resource Areas (MLRA) and Land Resource Regions (LRR) were used to form the NATSGO data base. The MLRA boundaries were developed primarily from state general soil maps. Map unit composition for NATSGO was determined from the 1982 SCS National Resource Inventory. NATSGO maps are made on a scale of 1:7,500,000.

The availability of digitized soil maps from the three geographic data bases is very limited at the present time. For Texas, the digitization of STATSGO maps is expected to be completed by the end of 1989. In addition, digitization of SSURGO maps has just been recently initiated so that no digitized SSURGO maps for the state are yet available to the public.

State DOT's

Transportation agencies planning to develop geographic information systems should also look in-house for sources of digital spatial data. Many transportation agencies have equipment and personnel devoted to surveying and mapping operations. For these agencies, it is likely that digital spatial data already exist in-house. If so, the suitability of using the available data in developing the GIS should be evaluated.

In Texas, the State Department of Highways and Public Transportation (SDHPT) has an on-going program for digitizing the highway network in the state. Detailed county maps are currently being digitized from 1:24,000 USGS quad sheets. These digitized maps contain data not only on highway routes, but on other features as well. Examples are transmission lines, power plants, pump stations, rivers, and USGS triangulation stations. To date, 50 counties have been digitized but not all have been annotated. Only about 18 of the 254 counties in the state are considered complete. However, there are also digitized maps for all districts within the state that do not contain as much detail as the digitized county maps but are already available to the public. These digitized files are updated every year.

Digitized district maps have been generated to automate the production of official highway maps for the state. District maps were digitized using different scales depending on the geographic extent of a particular district. Five different scales were used, namely: 1) 1 inch =

2.5 miles; 2) 1 inch = 3 miles; 3) 1 inch = 4 miles; 4) 1 inch = 5 miles; and 5) 1 inch = 6 miles. The individual district files can all be merged to form a digitized state map on a scale of 1:250,000.

The production of digitized maps within the Texas SDHPT is done using INTERGRAPH work stations and software. The digitized files are in Interactive Graphics Design System (IGDS) format. Maps are digitized manually by personnel from the Planning Division of the Texas SDHPT. Digitized maps are compared with paper maps to check for errors in the digitizing process and corrections are made accordingly. The digitized maps are in state plane coordinates.

Oak Ridge Highway Network

Oak Ridge Laboratory has developed a digital spatial data base consisting of 355,000 miles of interstates and primary roadways in the continental United States (Simkowitz, 1989). It is based on the 1:2,000,000-scale digitized maps developed by the USGS. The data base is divided into sub-networks for each state to facilitate manipulation. Each sub-network contains several files of nodes and links with their associated attributes. For a node, the geodetic location, and sometimes a city name are used as attributes. A link on the other hand is defined by its starting and ending nodes and by its shape. A separate file stores the information on the shape of each link.

Due to its small scale, the Oak Ridge data base is primarily useful for planning purposes at the state or federal level.

CONSIDERATIONS FOR DEVELOPING THE LAND BASE FOR THE TEXAS SDHPT

The preceding sections have presented several sources for digital spatial data. The utility of available digitized map files for developing the land base in a GIS would vary among different users. Consequently, it is important to examine an agency's requirements before a decision is made to use available digital spatial data. One of the immediate steps that can be taken is to check available digital cartographic data for the features required of the GIS land base. In connection with this, D-18 has identified the following feature requirements for the base map of the GIS:

1. County boundaries
2. Entire highway network including county roads (paved and unpaved)
3. City name and location of center of town
4. Major rivers, streams, and lakes
5. Railroads with symbols, and intersections of railroads with highways
6. USGS triangulation stations
7. Longitude and latitude grid

The above features are among those being digitized by D-10 for the detailed county maps. However, these maps contain more features than D-18 requires, and it is not possible, with the existing files, to select certain features and produced digitized maps containing only the features of interest. In addition, detailed county maps are not available for the entire state at the present time. However, digitized District maps for the entire state are available which contain less detail than the digitized county maps but which have most of the features required by D-18 except for the USGS triangulation stations. These digitized District maps contain all highways that are supported by the state and/or federal government and should be considered by D-18 in the development of the land base for the GIS. Other Divisions (or Districts) should follow a similar approach to define their base map requirements. The results can be used to assess and fine-tune the applicability of the current SDHPT data capture effort.

In addition to evaluating feature requirements, a more important factor to consider is the accuracy and precision required of the GIS land base. Accuracy and precision are not synonymous terms. Precision refers to the degree of refinement in a measurement. For example, a distance may be measured to the nearest tenth of a mile, or nearest tenth of a foot, depending upon the precision of the measuring instrument. Accuracy relates to the correctness of a measurement, whereby the accuracy may be improved through the procedure of taking repeated measurements (such as measuring a distance several times instead of once).

The accuracy and precision required for the digital land base significantly affects the cost and possibly even the feasibility of developing a GIS. The accuracy to be built into the land base will

undoubtedly be influenced by the needs of the various GIS users. On the one hand are users who are only interested in relative positions and are satisfied with 50 to 100 feet accuracies. For this group, available digital spatial data, such as those from the USGS or the Bureau of Census, may already be adequate. The accuracy of these digitized files depends of course on the base accuracy and precision of the source documents and on the quality of the digitizing process. For USGS maps, certain standards have been established against which the accuracy of published maps are tested. The standards, known as the U. S. National Map Accuracy Standards were first issued in 1941. The current version of the standards was issued in 1947 and is reproduced in Appendix A.

According to the standards, map scales of 1:20,000 or smaller shall have no more than 10 percent of points tested in error by more than 1/50 inch (0.5 mm). This criterion applies to the required horizontal accuracy of maps with scales 1:20,000 or smaller. Consequently, at a scale of 1:24,000 for example, a 1/50 inch error is equivalent to being off target by ± 40 feet on the ground. At a 1:100,000 scale, the corresponding accuracy in horizontal ground distance is approximately ± 167 feet. These accuracies represent the best that may be achieved with digitized USGS maps and do not include the additional inaccuracies which creep into the digitizing process.

At the other end of the scale, there are users who may have need for digitized maps with accuracies of 1 foot or less. These include engineering design personnel, utility departments, and land surveyors. The advantage of these highly accurate maps lies in their usefulness to a broad range of users. However, a highly accurate land base is expensive and takes a longer time to develop than one that is less accurate and precise.

In Texas, the primary need for a GIS was identified to be the graphical display and reporting of information on the highway network. This capability would significantly facilitate the development of maintenance and rehabilitation schedules within the different Districts. At the present time, the graphical display of information on the highway network is accomplished by manually color coding pavement sections on county maps following certain criteria. Consequently, if the primary purpose of the GIS is to automate this process, the required accuracy, at the very least, needs to be comparable with the accuracy achieved by manual

color coding. What is important in this instance is that the spatial relationships between routes are correct, e. g., roads intersect approximately where they should.

Another application identified by D-18 is truck routing. The Department regularly receives inquiries from truckers to identify optimum routes for hauling cargo. A trucker needs to plan his route to identify routes that he may want to avoid. Examples include routes with low overpass clearances, load zoned areas, bridges with insufficient vertical clearances or widths, bridges with load restrictions, and on-going road or bridge construction projects.

For vehicle routing purposes, the accuracy of the land base again depends on what the user expects to achieve. Fire departments and emergency medical services, for example, may have need for highly accurate digitized maps. For these users, a GIS must be able to establish the optimum route to get to a very specific location, e.g., a burning building, the scene of an accident, or a particular hospital. Department truck routing usually only involves hauling a load from one city to another (e.g., El Paso to Corpus Christi). Thus, for this application, the Department may not need the "door-to-door" level of detail normally required by fire fighters and emergency medical personnel. Consequently, digitized maps of lesser accuracy may suffice. Similarly, USGS DLG's, TIGER Files, or Texas SDHPT digitized maps may already be adequate to address highway department needs if routing operations need not be conducted at the "door-to-door" level of detail.

Another factor that must be considered when developing the digitized land base is the reference system that will be used to tie attribute data to the digitized maps. It is not uncommon within an agency to have files in which different reference schemes are used for a wide variety of attribute data. In this instance, there is a need for the various potential users of a GIS to establish a single, common reference system with which to tie attribute data to the digitized maps. Once a reference system has been established, a conversion program can be developed to have location information on all existing attribute data consistent with the reference system adopted for the GIS. In addition, maps can be digitized using the prescribed reference system.

Within the Texas SDHPT, the Texas Reference Marker System (TRMS)

project is developing a statewide unified reference system. TRMS will use a location key based on highway route and reference marker number (Lerner, et al., 1988). The reference marker is a physical post in the field similar to a milepost but numbered consecutively from state line to state line. Figure 5 illustrates the proposed highway route-reference marker. The marker number shows the approximate distance from a westernmost or northernmost point in the state. Latitude-longitude coordinates for the highway markers are scheduled to be obtained by the highway department. In connection with this, the use of global positioning is being considered for determining the latitude-longitude coordinates.

CAPABILITY OF THE TEXAS SDHPT TO DEVELOP THE LAND BASE FOR A GIS

The Texas SDHPT certainly has the equipment and expertise to develop and maintain the digitized land base for the GIS. This is evident from the on-going program to digitize county maps for the entire state. Moreover, the Department has the capability for providing and maintaining highly accurate digitized maps through aerial photogrammetry or GPS technology. In accordance with a 5-year implementation plan, 4 unmanned, automatic GPS Regional Reference Point (RRP) stations have already been installed in Austin, Dallas, Houston, and San Antonio (Merrell, 1987). Each RRP is designed to service an area bounded by a 200-kilometer radius (about 125 miles). These permanent RRP stations will be used in conjunction with roving field units to determine positions of points within the State. In addition, there is a plan to install RRP stations in other cities in Texas. These include Amarillo, Lubbock, El Paso, Odessa, Beaumont, and Corpus Christi. The construction of the two stations in Beaumont and El Paso have already been completed, and as of this writing, are only awaiting installation of the radio receivers. These two sites are expected to be operational in 1989. The network of existing and proposed RRP sites is illustrated in Figure 6.

The Automation Division of the Texas SDHPT is also experimenting with other approaches for establishing the positions of points through GPS. Development efforts are underway in the areas of kinematic differential positioning and photogrammetric mapping without ground control. Kinematic differential positioning involves the use of a GPS receiver mounted in a

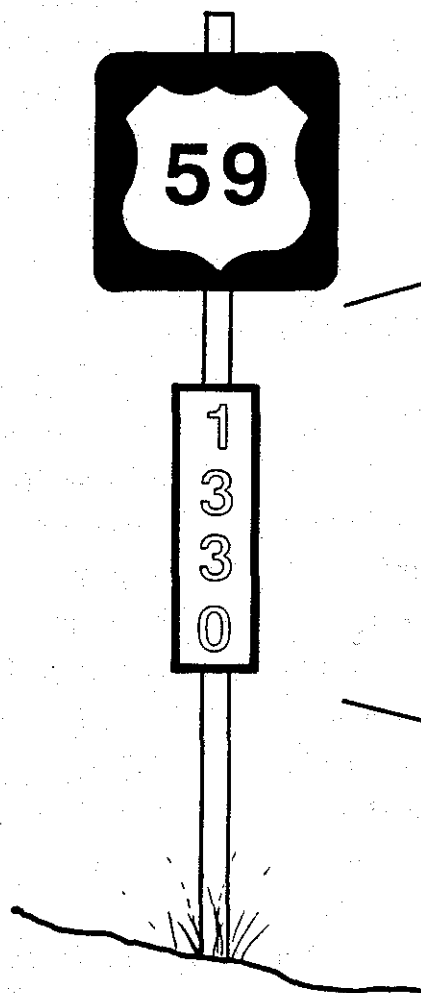

HIGH-LEVEL NETWORK FILE

HIGHWAY SYSTEM: US
HIGHWAY NUMBER: 0059
[HIGHWAY SYSTEM SUFFIX]: -
REFERENCE MARKER NUMBER: 1330
[REF. MKR. NUM. SUFFIX]: -
LATITUDE: 31: 45: 005
LONGITUDE: 94: 20: 010
MARKER POST DATE: 87/10
DISTANCE FROM ORIGIN: 149.000
[NOTATIONS]: -

Figure 5. Proposed Highway Route - Reference Marker for the Texas SDHPT (Lerner, et al., 1988).

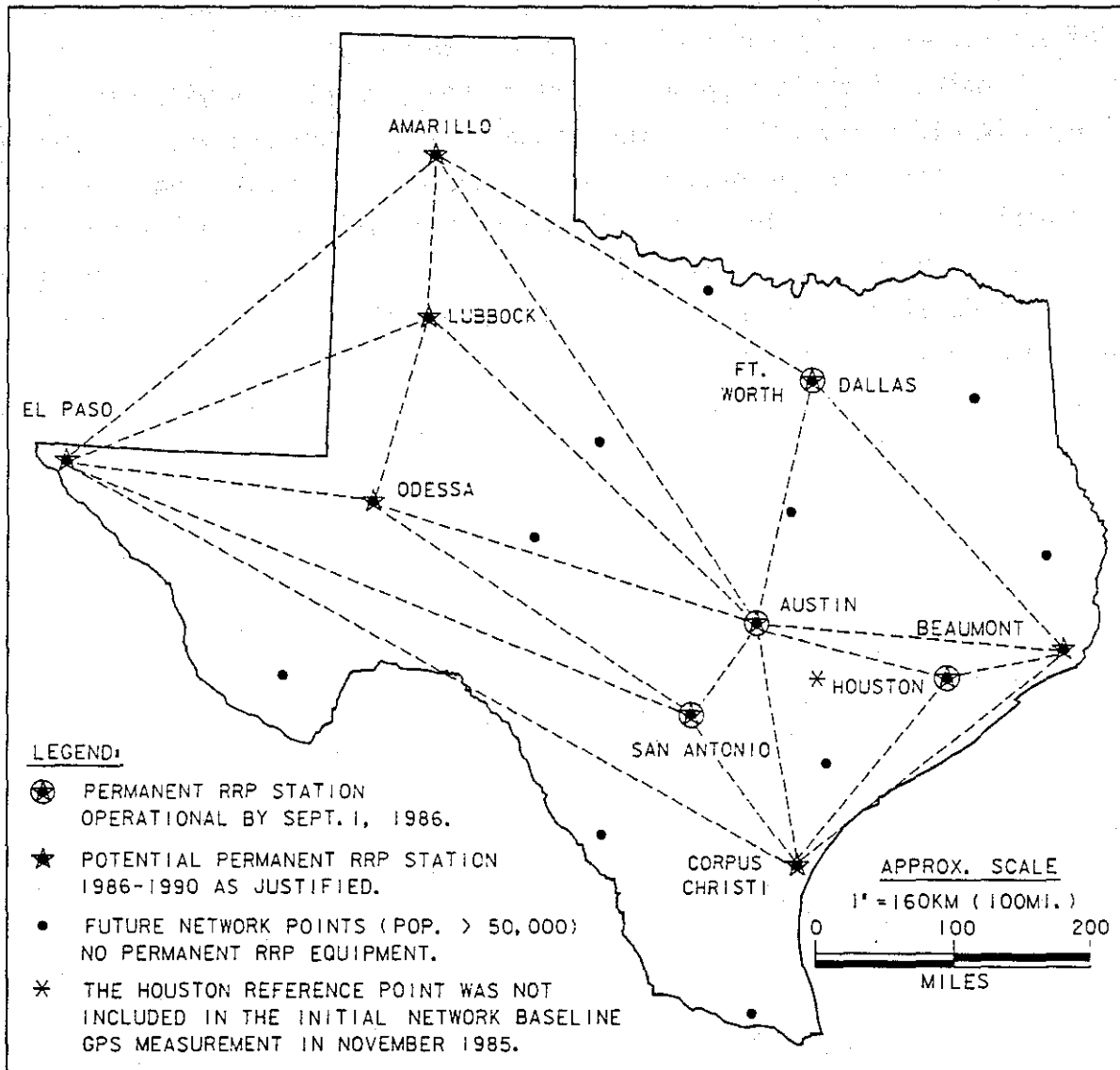

Figure 6. Network of Existing and Proposed RRP Sites in Texas (Merrell, 1987).

vehicle operating in conjunction with another receiver at a fixed site. The mobile unit travels from point to point while continuously tracking the satellites. In this way, the position of the mobile unit can be determined at any time. The positions of other points of interest such as highway route reference markers may be established by sighting at the point with an infrared or sonar gun while the vehicle is in motion.

Photogrammetric mapping without ground control is similar to kinematic differential positioning except that the GPS receiver is mounted in an aircraft. The Automation Division has been participating with the National Oceanic and Atmospheric Administration in evaluating this method. Preliminary results obtained were excellent and after a period of software and procedural requirements, it is anticipated that the technique should be developed well enough for production use in a year or two.

5. COMPARISON OF AVAILABLE GIS SOFTWARE

The following chapter on comparison of GIS software is strictly based on reviews of the vendor's literature and on other GIS software surveys. As of July 1988, the GIS WORLD journal identified, in preparation for a software survey, a list of 45 GIS vendors. Since it was inadequate (and also impossible) for the purpose of this pilot study to review all of the products available, it was decided to base the comparison on products that were better known or on systems that were seen in real working conditions, either during a vendor demonstration or at an installation where a particular system was actually being used.

The criteria used for the comparison considered the following system characteristics:

- Hardware Requirements - minimum computer requirements such as computer types, minimum RAM required, and mass storage required and recommended, numeric co-processor if applicable.
- Operating System - DOS, UNIX, XENIX, others.
- Data base Management - DBMS systems supported, features, and pertinent limitations if any.
- Miscellaneous System Capabilities - geographic referencing systems (map projections) supported; vector or raster type system; arc networking capabilities; automatic distance and area calculation capabilities; and other special features.
- System Price Range - for software only. CPU dependent.

SYSTEMS REVIEWED

ARC/INFO - Developed by Environmental Systems Research Institute (ESRI), of Redlands, California, ARC/INFO was first introduced in 1982, and is today one of the most flexible GIS's available. It runs on the broadest range of computers: IBM PC/AT or AT compatibles under DOS 3.1 or higher, DEC under VMS, Prime under PRIMOS, Sun, Apollo, RT, and Tektronics, all under UNIX, IBM mainframe and minicomputers under VM/CMS, and Data General under AOS. ARC/INFO handles most map projections and spatial data input formats and it can be interfaced with INFO, Oracle, SQL, RDB, and

other DBMS's. The PC version of the program was introduced in March of 1987 and is available in modules starting at \$2,500. The complete set of six modules, licensed to run on a single PC station costs \$9500. The minicomputer and workstation versions cost \$18,000 to \$88,000 depending on CPU. Packages for coordinate geometry (COGO), triangulated irregular network (TIN), and other engineering applications are available.

DELTAMAP - A product of Deltasystems, Inc. of Fort Collins, Colorado, is a GIS containing a specialized spatial DBMS for coordinate storage, manipulation, projection transformation, retrieval, and display. The system is implemented on the following computers: HP Vectra RS/20 and RS/25 under XENIX, HP 9000 series 300 and 800, CDC 910, and Sun under UNIX. DeltaMap can handle any of twenty map projections and, with the addition of the DeltaRef module, it will accept IGES, SIF, DLG, DXF, and other spatial data input formats. The GIS includes an internal attribute DBMS which is capable of SQL linkages to Oracle and INGRES RDBMS's, scripting capability and applications manager software. Prices for DeltaMap start at \$8,000 for the HP Vectra machines and \$27,000 for the workstations. Additional modules include: DeltaCell for raster and DEM processing (\$8,000), DeltaRef for data import/export (\$3,000), and DeltaCom for intercomputer DBMS communications (\$5,000).

EARTH ONE - Developed by C. H. Guernsey & Company, this package incorporates a comprehensive data management system with capabilities for the capture and maintenance of graphics and facilities data. The system will run on an IBM PC/AT or other AT compatibles under DOS 3.2 or higher. Also, a UNIX version that will run on the Sun family of workstations is currently under development. EARTH ONE can handle all map projections, and it accepts DLG, and DXF data input formats. However, it outputs all map products only in DXF format. All data base management functions are handled via a fully integrated proprietary RDBMS with QBE and SQL querying capabilities. Price: \$12,000 to \$28,000.

SYSTEM 9 - A GIS developed by WILD Heerbrug Systems of Englewood, Colorado, that integrates connectivity among features, associativity of attributes with features, and comprehensive and flexible analysis and reporting functions. This system, which is designed to run on the Sun family of workstations under UNIX and SunOS, can handle all map projections and several input formats such as ASCII, ISIF, DLG, SNA, GBF, DIME,

and TIGER. Its data base management functions are handled through a specially designed data base structure which interfaces with the Empress Data Sciences RDBMS. The data base structure supports specialized applications such as COGO, polygon processing, digital terrain modeling, network analysis, and others. Approximately 900 stand-alone application programs from third party vendors are available. A single workstation license for SYSTEM 9 costs \$40,000.

TransCAD - This comprehensive GIS, specially designed for planning, management, operation, and analysis of transportation systems and facilities, was developed by Caliper Corporation of Newton, Massachusetts. It incorporates functions for digital mapping, storage and retrieval of geographically-based data, creation of transportation and operations research models, statistical procedures, and presentation graphics, all within a user-friendly environment. This GIS, which runs on IBM PC/AT's or AT compatibles under DOS 3.1 or higher, and that automatically converts from any map projection to latitude-longitude is limited only to DLG and TIGER input formats. Data base management is provided via a fully integrated proprietary RDBMS with SQL interface. The current retail price for the system is \$20,000.

TIGRIS - For Topologically Integrated Geographic and Resource Information System, developed by Intergraph Corporation of Huntsville, Alabama, is an object-oriented GIS environment which provides core capabilities such as data collection, data management, data manipulation, query and presentation. The TIGRIS GIS Environment (TGE) is designed to run under UNIX on the Intergraph Clipper family of workstations. It handles most map projections, produces IGDS, DXF, DIME, TIGER, SIF, DME, HPGL, and DLG input/output formats. TIGRIS uses a proprietary object oriented RDBMS. Add on modules include: Analyst, for query and spatial analysis (\$10,000); Imager, for image processing (\$20,000); Modeler, for terrain modeling (\$10,000); Scanned Data Capture, for hardcopy data conversion (\$10,000); and Finisher, for cartographic detailing (\$5,000). The price for the basic TGE package (MAPPER + MICROSTATION 32) is \$8,300.

The information presented in the preceding is summarized in Table 3.

Table 3. Comparison of Selected GIS Software Products.

Vendor/Product	System Type	System Interface To:	Map Input Data	Projections	Hardware (Operating) System	Price (Software) Only
ENVIRONMENTAL SYSTEMS RESEARCH INSTITUTE ARC/INFO	VECTOR AND RASTER	INFO, ORACLE, SQL, RDB	SIG, DLG, DIME, TIGER	LAT/LONG, UTM, STATE PLANE, & OTHERS	IBM PC (DOS) DEC (VMS) PRIME (PRIMOS) SUN (UNIX) APOLLO (UNIX) RT (UNIX) TEKTRONIC (UNIX) IBM (VM/CMS) DATA GENERAL (AOS)	PC ARC/INFO \$ 2,500 - \$ 9,500 WORK STATION ARC/INFO \$ 18,000 - \$ 88,000 DEPENDENT OF CPU
DELTA SYSTEMS DELTAMAP	VECTOR AND RASTER	ORACLE, INGRES	SIF, DXF, DLG, DEM IGDS	LAT/LONG, UTM, STATE PLANE, AND 20 OTHERS	HP 9000 -300/800 (UNIX) SUN (UNIX) HP VECTRA RS/20, RS/25 (XENIX) CD 910 (UNIX)	\$ 8,000 FOR VECTRAS \$ 27,000 FOR WORK STATIONS
C. H. GUERNSEY AND COMPANY EARTH ONE	VECTOR AND RASTER	ISAM (INTERNAL)	SIF, DXF, DLG	LAT/LONG, STATE PLANE AND OTHERS	IBM PC OR AT COMPATIBLES (DOS)	\$ 12,000 - \$ 28,000
WILD HEERBRUGG SYSTEMS SYSTEM 9	VECTOR	EMPRESS	ACAD, MOS STF, DLG	ALL MAP PROJECTIONS	SUN (SUN OS, UNIX)	\$ 40,000
CALIPER CORP. TRANSCAD	VECTOR	PROPRIETARY RDBMS	DLG/TIGER	AUTOMATICALLY CONVERTS ANY PROJECTION TO LAT/LONG	IBM PC/AT OR AT COMPATIBLE (DOS)	\$ 20,000
INTERGRAPH CORP. TIGRIS	VECTOR AND RASTER	PROPRIETARY OBJECT-ORIENTED	SIF, DXF, DLG, DIME, TIGER, DME, HPGL	LAT/LONG, UTM, STATE PLANE	INTERGRAPH CLIPPER FAMILY OF WORK STATIONS (UNIX)	TGE \$ 8,300 UP TO \$ 45,000

6. EXAMPLE DEMONSTRATION OF A GIS USING PC ARC/INFO

An actual demonstration of GIS applications to the identification of maintenance and rehabilitation needs was also conducted during the course of this research study. The demonstration was conducted using data from the Pavement Evaluation System (PES) data base for Travis County, Texas. The demonstration was developed using a GIS software called PC ARC/INFO that was loaned at no cost to the project by its developer, Environmental Systems Research Institute (ESRI). The demonstration was presented to personnel from D-18 and D-19, and to the members of the Pavement Management Steering committee. An objective of the demonstration was to illustrate the potential application of a GIS towards satisfying the most urgent need of the Districts, namely, the automated production of maps highlighting substandard pavement sections. Additionally, the demonstration was conducted to illustrate the capabilities of a GIS for displaying an attribute or a combination of attributes of PES sections, and for producing tabular reports and map-type products based on queries done to the PES data base. The present chapter documents the GIS demonstration that was conducted.

PC ARC/INFO SOFTWARE DESCRIPTION

PC ARC/INFO is a software system for managing geographic information. This system integrates geographic analysis and modeling capabilities with a fully interactive system for acquisition, management, and display of spatial data.

PC ARC/INFO consists of a series of modules, including:

- **Starter Kit** used for map creation and digitization, attribute table creation, topologic data structuring, map plotting system, and host computer communication.
- **PC INFO**, a stand-alone fully featured data base management system.
- **PC ARCPLOT** used for interactive map creation and display, graphical query, and generation of high quality hardcopy maps.
- **PC ARCEDIT** - supports sophisticated graphics editing for coverage creation and update.

- **PC OVERLAY** - supports polygon overlay, line and point-in-polygon overlay, and buffer generation.
- **PC NETWORK** - handles analytical functions for modeling real networks and performs optimal routing, districting, address matching, and geocoding.
- **PC DATA CONVERSION** - converts grid cell and vector formats to ARC/INFO or vice versa.

The Starter Kit is the foundation of the system, and as such it has to be installed before any other modules. It provides the basic GIS tools such as the Arc Digitizing System (ADS) used to digitize map coverages; CLEAN and BUILD procedures to create topology from coordinates; the TABLES program that directly interacts with PC INFO to integrate attribute data with map entities; HELP menus and screens that provide reference to both ADS and TABLES commands; ESRI's Plot System for viewing maps on the screen or for sending them to a plotter or graphics printer; and a macro language (SML) that can be used to create a user interface.

Of the PC ARC/INFO modules mentioned above, only the Starter Kit and PC ARCPLOT were used to develop the demonstration. The Starter Kit was used to digitize the base map, highway network, county boundaries, and the Austin city limits. PC ARCPLOT was used to create the display map; assign colors, line types and weights, and labels to map entities; perform queries and highlight selected highway sections; and plot maps that resulted from various analysis queries.

CREATING THE TRAVIS COUNTY PAVEMENT MANAGEMENT SYSTEM GIS-BASE MAP

The selection of the geographic area that would form the base map for the demonstration was based upon the following requirements:

- The area had to contain a representative sample of the Texas highway network, that is, at least one of each of the highway types, from interstate highways to farm to market roads.
- The PES data for the above network had to be as complete and as current as possible.

Since the Travis county area complied with the above requirements, it was selected for the demonstration.

Several sources were available from where an appropriate base map can be obtained. These included various digital and paper map products from agencies such as the Bureau of Census, the U.S. Geological Survey, and the Transportation Planning Division of the Texas State Department of Highways and Public Transportation. The final decision on the map base was to use the Texas SDHPT General Highway Map product for Travis County. Besides incorporating the complete highway network for the county, it also included the two mile highway sections used by the state to maintain its roadway inventory. In order to gain some experience in map preparation and digitization, it was further decided to use a paper map product instead of a digital one. This would also ensure that the base map would contain only the elements that were of interest to the study: county boundaries, highway networks, and city limits.

The creation of the base map for the pilot study was accomplished in three phases: 1) map digitization; 2) PES attribute data integration; and 3) final base map production. A description of the three phases follows next:

Map Digitization

The digitization of all base map coverages was performed with the Starter Kit's Arc Digitizing System (ADS) utility. The Texas SDHPT General Highway Map for Travis county consisted of one base sheet and ten supplementary sheets. Since the base sheet covers the whole county while the supplementary sheets show adjacent areas of the county in greater detail, it was decided that the base sheet would be used for the digitizing exercise. Two steps had to be performed before the digitizing process could begin. First, six reference points or tics were marked on the map and labeled eleven through sixteen. The locations of these tics were arbitrary so they were made to correspond with the intersections of the map's latitude-longitude grid. Also, since most of the highway network's two mile sections are depicted on the supplementary sheets but not on the base sheet, they had to be transferred to the latter.

The highway network selected for the study comprised the following

roadways: Interstate Highway 35 (IH 35), U.S. Highways 183 and 290 (US 183 and US 290), State Highway 71 (SH 71), and Farm to Market Road 973 (FM 973). All these roadways were digitized into a single layer or coverage named HIGHWAYS. The other two coverages, CONBOUND and AUSTIN that made up the map base, contain the county boundary and Austin city limits respectively. These two coverages were digitized using the same set of reference tics as the one in the HIGHWAYS coverage allowing them to be perfectly overlaid with it to compose the land map. Since both the AUSTIN and CONBOUND coverages represent only boundaries for visual orientation, no topology was built into them. In contrast, since the HIGHWAYS coverage represents the highway network, each two mile section was digitized as an arc, with beginning and ending nodes. Thus, the whole network was represented by a series of sequential arcs joined together by nodes. During digitizing, a unique ID number was assigned to each of the arcs representing highway sections. Once the digitizing of this coverage was complete, the BUILD utility was used to make an Arc Attribute Table (AAT) which contained the topological relationships of the arcs that form the highway network (Figure 7).

PES Attribute Data Integration

The data base used for the pilot study was a subset of the 1987 PES data set for District 14. The Travis county data was extracted from this subset using option one of the MICROPES program (Scullion, Paredes, Fowler, and Fernando, 1989). Furthermore, since PES records contain 47 variables and many of them were not relevant to the study, it was decided to use only the variables that were the most applicable to the problem at hand. Table 4 lists the 18 variables that were selected for the PES attribute data base. The first variable in the table, HWY-ID does not belong to the PES data set. It was added to store the highway section ID number that was used to link the attribute data with the topological data in the AAT created during the digitizing process described above.

The TABLES utility from the STARTER KIT was used to create an INFO template with the 18 variables that formed the attribute data set and to input the data. Special care was taken to make sure that the highway ID variable, HWY-ID, in the attribute data set matched the HWY-ID variable of

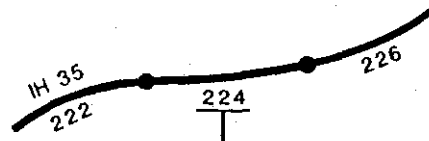

HIGHWAYS.AAT

FROM NODE	TO NODE	L POLYGON	R POLYGON	LENGTH	HWY #	HWY ID
2	3	0	0	1.012	2	222
3	4	0	0	1.005	3	224
4	5	0	0	0.918	4	226
.
.
.

HWY ID	PRE	NUM	LANE	RUTT	BLOCK	PAT	FAIL	ALLIG	LONG	TRANS	PSI	SPEED	PTYPE	FC	WIDTH	AADT	18KIPS
222	IH	35	S	100	0	0	0	100	10	0	42	65	6	1	36	0920	30126
224	IH	35	S	100	0	0	0	0	100	0	40	65	5	1	36	9166	38809
226	IH	35	R	100	0	0	0	0	100	0	40	65	5	1	36	16666	55456
.
.
.

Figure 7. The Arc Attribute Table is "Linked" Together With the Highways Data Base Through the HWY-ID Variable Which Was Used.

Table 4. Variables Used To Create The HIGHWAYS Data Base.

Column	Item Name	Width	Output	Type*
1	HWY-ID	3	4	I
4	PRE	2	3	C
6	NUM	3	4	I
9	LANE	1	2	C
10	RUTT	3	4	I
13	BLK	3	4	I
16	PAT	3	4	I
19	FAIL	3	4	I
22	ALLIG	3	4	I
25	LONG	3	4	I
28	TRANS	3	4	I
31	PSI	2	3	I
33	SPEED	2	3	I
35	PTYPE	2	3	I
37	FC	1	2	I
38	WIDTH	2	3	I
40	AADT	5	6	I
45	KIPS	5	6	I

* I = integer
 C = character

of its corresponding highway section in the AAT. Once this was accomplished, the records in these tables were linked together using the common HWY-ID variable as the key (Figure 7), resulting in a fully relational geographic data base for the highway network.

Base Map Production

Once the geographical data base was complete, the next step was to produce the base map that would be used as a basis for displays and queries. This step was accomplished by using the map composition features of PC ARCPLLOT. PC ARCPLLOT allows the user to display maps created from a number of coverages using different colors, line types, line widths, text annotations like labels and titles, legend and title boxes, and frames.

Map composition in PC ARCPLLOT is a process that is performed one step at a time. For instance, the creation of the base map for the pilot study was done by first defining the map extent (boundaries); then, each of the coverages (CONBOUND, HIGHWAYS, and AUSTIN) were drawn, one at a time, using desired colors and line types until the map was completed. Next, all text (i.e., labels and titles), were added to complete the base map (Figure 8). This step-by-step process had to be repeated every time the map is displayed. In order to avoid such a tedious task, PC ARCPLLOT includes a Simple Macro Language (SML) that can be used to create a batch type file that executes all steps for creating the base map so that map composition can be performed by typing in a single command. For the pilot study, the macro TRAVIS.SML was created to display the complete base map.

USING THE TRAVIS COUNTY PAVEMENT MANAGEMENT SYSTEM GIS

Queries to the Travis GIS are done through PC ARCPLLOT, using one or a combination of commands to select highway sections according to a desired Zcriterion or set of criteria. The querying and display of selected data is a straight forward process that involves three steps: a) base map display, b) selection of the desired section data, and c) displaying the selected data on the base map. A brief description of these steps follows.

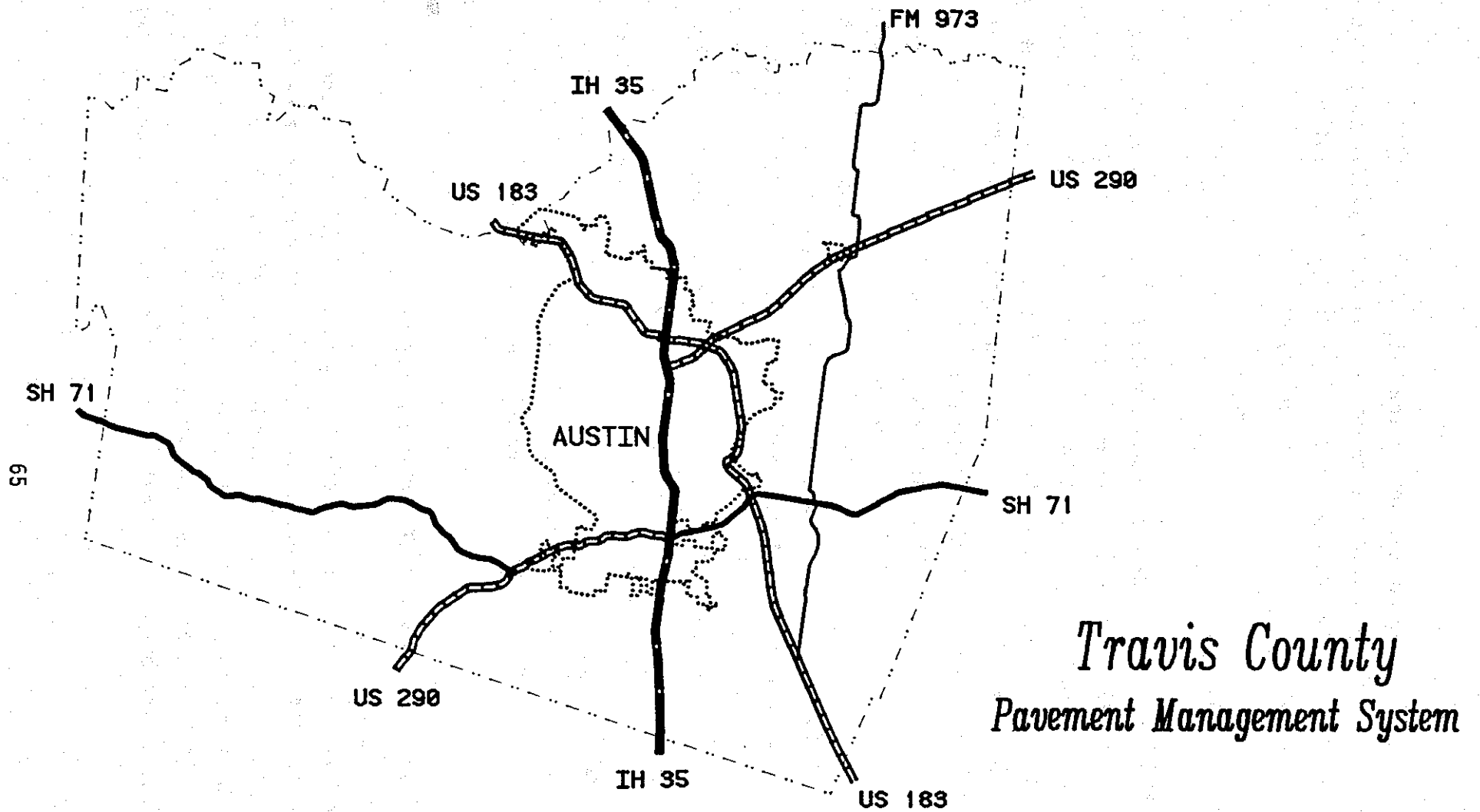

Figure 8. Base Map for the GIS Pilot Study.

- a) The base map, as discussed previously, is displayed by typing in (within PC ARCPLOT) the SML command @TRAVIS.SML.
- b) Selection of highway sections within PC ARCPLOT is done through the RESELECT command. This command can be used with any combination of logical operands to select data by desired ranges, or it can be used with the asterisk (*) or point options. The * option allows the user to select data by drawing a box, directly on the map, around the sections he/she wishes to select. The point option is also used directly on the map, but it will select sections by pointing at them. By contrast, a query done with logical operands could be used, for instance, to select all highway sections with PSI values between 30 and 35.
- c) Selected data display can be done by either highlighting or annotation. To highlight data, the user first selects the color and width of the highlight line and then uses the ARCS PC ARCPLOT command to display the highlight on the map. To annotate or label selected data, the user selects the type and size of the text to be used and then displays the information on the map using the LABEL command. Every time the user wants to select and display a new set of highway sections, the map base has to be redrawn and the section data reset to include all records. The RESET and CLEAR commands respectively are used for this purpose.

SUMMARY

The pilot project described herein demonstrated the feasibility of using PES data within a GIS environment for producing maps displaying substandard pavement sections in both highlight and annotated forms. Implementation of the system took four weeks, two of which were spent solely in the familiarization with the PC ARC/INFO software. Another week was spent becoming proficient in the art of manual digitizing, a process that is not very hard to learn once it is realized that the process itself must be preceded by strategic planning and map preparation steps. The remaining development time was spent integrating the PES attribute data, composing the base map, and testing the querying system.

The PC ARC/INFO software proved to be very flexible and to possess

many capabilities for developing sophisticated GIS applications. Even though the system is not all that easy to learn, due to the large number of commands that must be used within each of its environments, its well-designed modular structure, the adequacy of the command reference sections in the user manuals, and its many features and capabilities make it a sound GIS development environment.

It should be noted that literature for other GIS development systems was also reviewed and all seemed to possess the capabilities for developing GIS's for pavement management applications. The sole reason for utilizing PC ARC/INFO to develop this pilot study was because the system was made available at no cost to the research project by its manufacturer, the Environmental Systems Research Institute (ESRI).

7. RECOMMENDATIONS FOR FUTURE RESEARCH

The small-scale feasibility study reported herein represents the initial effort made to implement a geographic information system for the Texas highway department. As a preliminary study, it has made the following significant contributions towards realizing this objective:

1. The study has identified Department needs that can be satisfied through a GIS.
2. It has provided an introduction to GIS and has reviewed on-going state and federal activities aimed at developing transportation applications of this technology.
3. It has identified issues that are crucial to the successful implementation of a GIS in a DOT environment.
4. It has reviewed methods for developing one of the major elements of a GIS - the geographic data base.
5. It has identified sources of digital cartographic data and has laid out the considerations for developing the GIS land base vis-a-vis the needs identified by the Department.
6. It has identified capabilities of the Department for developing and maintaining the land base for a GIS.
7. It has reviewed available GIS software.
8. It has demonstrated network level PMS applications of GIS.

The study conducted herein has generated significant interest within the Department for developing transportation applications of geographic information systems. In order to build upon the accomplishments of this research project, the following recommendations are hereby made:

1. A follow-up effort to develop a prototype GIS is recommended. This research effort should be conducted under the direction of the Automation Division (D-19) which is responsible for coordinating statewide automation studies. The prototype should be developed for a selected county in Texas and the entire study itself would serve as an "experiment" in the development and implementation of a GIS for transportation applications. The

study could provide valuable lessons on how to develop and implement geographic information systems in a DOT environment and the findings obtained would be of immediate relevance to any subsequent research aimed at developing a Department-wide GIS for the Texas SDHPT. The proposed study is envisioned to take two years and would involve the following tasks:

- a) Identification of user and data requirements for a GIS in the selected county.
 - b) Development of an implementation schedule for the GIS that will address immediate and long-term goals.
 - c) Selection and acquisition of GIS hardware and software
 - d) Development of GIS applications with emphasis on user requirements that can be addressed within the proposed study period. The initial applications will most likely be based on available digital cartographic data bases such as the USGS DLG's and the Bureau of Census TIGER/Line files. Possible applications include:
 - Displays of pavement condition or inventory items
 - Accident "black-spot" identification
 - Possible M & R programs
 - Traffic flow maps
 - Interfacing maps with ARAN video (user points to a map and the appropriate video images are produced to simulate driving on the highway)
 - Interfacing with MMIS to display maintenance expenditures
 - Vehicle routing
 - Incident response
 - e) Demonstration of initial GIS applications developed
 - f) Preparation of project report(s)
2. The present study identified user requirements for a GIS primarily related to the concerns of the Maintenance and Operations Division (D-18) under which Project 930 was funded. To develop a Department-wide GIS, a feasibility study on a much larger scale is

warranted. This feasibility study, conducted under the direction of D-19, would address Department-wide requirements for a GIS and would develop a timetable for GIS implementation within the Texas SDHPT. In addition, the feasibility study would develop a cost estimate for implementing a GIS.

3. GIS development efforts should be coordinated with current Department efforts to develop a Pavement Management System that satisfies Federal Highway Administration guidelines.
4. A committee should be established to be responsible for GIS development and implementation within the Texas SDHPT. The Pavement Management Steering Committee is a logical choice upon which to place this responsibility but this is a matter for the Department to decide. The important point is that somebody in the Department must serve as a champion for GIS development and implementation if the project is to be successful.
5. A central policy to guide the development and implementation of a Department-wide GIS must be established.
6. GIS development efforts should be coordinated with current referencing projects within the Department, primarily the Texas Reference Marker System project. In addition, conversion of existing data bases to the common referencing scheme should be initiated. As appropriate, a plan must also be formulated so that existing data bases with various referencing schemes can be used in the GIS until such time that the common referencing system is completely implemented within the Texas SDHPT.
7. An evaluation of low cost GPS technology should be made to aid in the development and maintenance of the GIS land base.

REFERENCES

- Bacon, M. L., and Moyer, D. D., "Geographic Information Systems (GIS) for Transportation Symposium," Final Report, American Association of State Highway and Transportation Officials, Orlando, Florida, 1989.
- Colorado Department of Highways (CDOH), "Geographic Information Systems: CDOH Program Status," 1989.
- Dangermond, J., "A Classification of Software Components Commonly Used in Geographic Information Systems," in Design and Implementation of Computer-Based Geographic Information Systems. ed. Peuquet, Donna, and John O'Callaghan (New York: Amberst, 1983), pp. 1-23 to 1-57.
- Dildine, G., Shuller, E., Warren, R., Crowe, N., Idol, D., Hoke, W., and Tilley, L., "Geographic Information Systems (GIS): Feasibility Study," North Carolina Department of Transportation, Division of Highways, 1988.
- Dueker, K. J., "Geographic Information Systems and Computer Aided-Mapping," American Planning Association Journal, Summer, 1987. pp. 383-390.
- Federal Interagency Coordinating Committee on Digital Cartography (FICCDC), "A Summary of GIS Activities in the Federal Government," Virginia, 1988.
- Fletcher, D., "Modeling GIS Transportation Networks," Proceedings, URISA Conference, Vol. 2, Los Angeles, 1988, pp. 84-92.
- Lerner, L., Burkhardt, N., and Rogers, C., "State Department of Highways and Public Transportation: Overview of Highway Network Prototype," Texas SDHPT, Austin, Texas, 1988.
- Merrell, R. L., "Conceptual Plan and Implementation Schedule for Satellite Surveying in SDHPT," Texas State Department of Highways and Public Transportation, Austin, Texas, 1983.
- Merrell, R. L., "GPS: A Cost-Effective Engineering Tool," paper presented at the Swedish Road Design Symposium, Borlange, Sweden, 1987.
- Moellering, H., "A Review and Definition of 0-, 1-, and 2- Dimensional Objects for Digital Cartography," in Proceedings: Second International Symposium on Spatial Data Handling. ed. International Geographical Union (New York: Williamsville, 1983), pp. 616-627.
- Morehouse, S., "ARC/INFO: A Geo-Relational Model for Spatial Information," in Auto-Carto 7 Proceedings: Digital Representations of Spatial Knowledge. eds. American Society of Photogrammetry and American Congress on Surveying and Mapping (Washington: 1985), pp. 388-397.

- Nyerges, T.L., and Dueker, K. J., "Geographic Information Systems in Transportation," Draft Report to FHWA Office of Planning, Washington, D.C., 1988.
- Peterson, B., and Smyre, J. L., "HPMS Locational Enhancements, Draft of Final Project Report," Oakridge National Laboratory, Oakridge, Tennessee, 1984.
- Peuquet, D. J. and Boyle, A. R., "Raster Scanning, Processing and Plotting of Cartographic Documents," SPAD Systems Ltd., New York, 1984.
- Reybold, W. U., "Soil Geographic Data Bases," FDC Newsletter, No. 8, U. S. Geological Survey, Virginia, 1988.
- Scullion, T., Paredes, M., Fowler, J., and Fernando, E. G., "Micro-PES Release 1.0, User's Manual," Research Report 930-1, Texas Transportation Institute, Texas A&M University, College Station, Texas, 1989.
- Scullion, T., "Pavement Management: Where Do We Go From Here?," Research Report No. 930-2, Texas Transportation Institute, Texas A&M University, College Station, Texas, June 1989.
- Simkowitz, H. J., "Geographic Information Systems: An Important Technology for Transportation Planning and Operations," paper presented at the 68th Annual Meeting of the Transportation Research Board, Washington, D.C., 1989.
- Skiles, J. M., "Tools and Techniques Used In Scan Conversion of Geographic and Facilities Data," Proceedings, GIS/LIS Conference, Vol. 1, San Antonio, Texas, 1988, pp. 58-67.
- Sobel, J., "Principal Components of the Census Bureau's TIGER File," paper presented at the 9th Annual Applied Geography Conference, New York, 1986.
- Stiefel, M., "Mapping Out the Differences Among Geographic Information Systems," The S. Klein Computer Graphics Review, Fall, 1987, pp. 73-87.
- Woodsford, P. A., "Vector Scanning of Maps," paper presented at the GIS/LIS Conference, San Antonio, Texas 1988.

APPENDIX A

UNITED STATES NATIONAL MAP ACCURACY STANDARDS

With a view to the utmost economy and expedition in producing maps which fulfill not only the broad needs for standard or principal maps, but also the reasonable particular needs of individual agencies, standards of accuracy for published maps are defined as follows:

1. Horizontal accuracy. For maps on publication scales larger than 1:20,000, not more than 10 percent of the points tested shall be in error by more than 1/30 inch, measured on the publication scale; for maps on publication scales of 1:20,000 or smaller, 1/50 inch. These limits of accuracy shall apply in all cases to positions of well-defined points only. Well-defined points are those that are easily visible or recoverable on the ground, such as the following: monuments or markers, such as bench marks, property boundary monuments; intersections of roads, railroads, etc.; corners of large buildings or structures (or center points of small buildings); etc. In general what is well-defined will also be determined by what is plottable on the scale of the map within 1/100 inch. Thus, while the intersection of two road or property lines meeting at right angles, would come within a sensible interpretation, identification of the intersection of such lines meeting at an acute angle would obviously not be practicable within 1/100 inch. Similarly, features not identifiable upon the ground within close limits are not to be considered as test points within the limits quoted, even though their positions may be scaled closely upon the map. In this class would come timber lines, soil boundaries, etc.
2. Vertical accuracy, as applied to contour maps on all publication scales, shall be such that not more than 10 percent of the elevations tested shall be in error more than one-half the contour interval. In checking elevations taken from the map, the apparent vertical error may be decreased by assuming a horizontal displacement within the permissible horizontal error for a map of

that scale.

3. The accuracy of any map may be tested by comparing the positions of points whose locations or elevations are shown upon it with corresponding positions as determined by surveys of a higher accuracy. Tests shall be made by the producing agency, which shall also determine which of its maps are to be tested, and the extent of such testing.
4. Published maps meeting these accuracy requirements shall note this fact in their legends, as follows: "This map complies with National Map Accuracy Standards."
5. Published maps whose errors exceed those aforesaid shall omit from their legends all mention of standard accuracy.
6. When a published map is a considerable enlargement of a map drawing (manuscript) or of a published map, that fact shall be stated in the legend. For example, "This map is an enlargement of a 1:24,000-scale published map."
7. To facilitate ready interchange and use of basic information for map construction among all Federal mapmaking agencies, manuscript maps and published maps, wherever economically feasible and consistent with the use to which the map is to be put, shall conform to latitude and longitude boundaries, being 15 minutes of latitude and longitude, or 7 1/2 minutes, or 3 3/4 minutes in size.