

IMPACT BEHAVIOR OF SIGN SUPPORTS

A PROGRESS REPORT

By

Charles H. Samson, Jr.
Research Engineer

Neilon J. Rowan
Assistant Research Engineer

Robert M. Olson
Assistant Research Engineer

Danny R. Tidwell
Assistant Research Engineer

Research Report Number 68-1

Sign Support Structures
Research Project Number 2-5-63-68

Sponsored by

The Texas Highway Department
In Cooperation with the
U. S. Department of Commerce, Bureau of Public Roads

March, 1965

Second Printing, February, 1967

TEXAS TRANSPORTATION INSTITUTE
Texas A&M University
College Station, Texas

ACKNOWLEDGMENTS

The authors wish to acknowledge the cooperative efforts of Mr. D. L. Hawkins and other engineers of the Bridge Division of the Texas Highway Department in the conceptual design of the "slip joint" and the fracture joint used in the unbraced post, and for collaboration with the Texas Transportation Institute staff in further refinements and modifications.

The authors wish further to acknowledge the contribution of the engineers of the Houston Urban Office for the initial design of the braced-leg sign support.

FOREWORD

Studies involving the impact behavior of certain types of supports for large signs are described in this progress report. The selection of the types of supports considered herein has been predicated upon current design procedures and the development of interim designs which would minimize hazards. Certain devices have been introduced into the sign supports, and full-scale crash tests have been conducted in order to observe the impact behavior of supports containing these devices. These studies have resulted in revised support design details which have been included in current construction operations in Texas. Consideration has also been given to the possible utilization of a variety of support configurations which have not been constructed or tested.

The method of approach to the research reported herein was dependent upon the successful development of a full-scale crash test facility employing high-speed motion picture cameras to record the behavior of the sign support upon impact when struck by a standard size automobile. Considerable information has been secured on the qualitative nature of support behavior, and the introduction of certain devices, as explained in detail in this report, has resulted in observable improvements in impact characteristics. In addition to these qualitative results, the method of procedure just described has been useful in the development of concepts of post behavior under impact. It is anticipated that an idealized mathematical model will evolve to provide additional quantitative information on this behavior. Supporting tests are being conducted to evaluate certain materials for use in the devices utilized in these studies. Other studies involving the effects of wind on signs are being conducted. These latter functions are not included in this report.

This experimentation is the initial phase of a research project on sign support structures currently being conducted by the Texas Transportation Institute in cooperation with the Texas Highway Department and the U. S. Bureau of Public Roads. It is not intended that the studies presented herein reflect final research recommendations, but rather that they present a complete series of tests which have resulted in tentative designs that show promise of providing an economical method for reducing hazards.

IMPACT BEHAVIOR OF SIGN SUPPORTS

A PROGRESS REPORT

INTRODUCTION

Large signs are necessary to provide adequate signing for today's high-speed freeway traffic. These are positioned over the roadway or near the edge of the pavement because of the complexity of multilane facilities and traffic operation thereon. Furthermore, their size calls for larger and stronger structural members to support them and to give resistance against forces induced by the wind. The formidable solidity of the structural supports required for these signs has resulted in their constituting a definite safety hazard for occupants of vehicles that collide with them.

Basically, there appear to be three primary characteristics of a sign support which contribute substantially to the severity of a collision. These are the sign support's (1) mass or weight, (2) flexural rigidity or stiffness, and (3) condition of fixity at the base. Perhaps other characteristics exist which contribute to the severity of a collision, but the initial investigation described in this report has been based on efforts to utilize or reduce the influence of these three characteristics.

The objectives of the initial phase of the research being reported were to design and test sign supports (1) with substantial reduction in the total mass involved, (2) which themselves will yield under the impact of collision, and (3) which will readily disconnect from their foundations when struck by a vehicle. In this preliminary phase of the research two basic post designs were tested. They shall be referred to as the braced-leg support and the unbraced post support.

CRASH TEST PROCEDURES

One of the first requirements in the research was to develop a satisfactory means of launching vehicles into full-size sign supports under conditions of controlled placement, speed, and angle of incidence. The launching procedure finally selected has been termed the "reverse-tow" procedure, which is illustrated in Figure 1. This arrangement provides a one-to-two ratio in speeds of the tow car and the crash car, and with a high powered tow vehicle it was possible to attain crash car speeds of 50 to 60 mph within the 600-foot length of guide rail.

Two guide rail systems have been employed. The system being used predominantly in these tests is an elliptical tube rigidly attached to the pavement. A large steel channel which guides the vehicle along the rail is attached to the underside of the crash vehicle. As the crash vehicle reaches the end of the rail, the cable is automatically released and pulled free, allowing the vehicle to be in free motion when impact occurs.

Four motion picture cameras were used to record each crash. One of these was a high-speed camera capable of attaining photographic speeds of approximately 1000 pictures per second. Three motion picture cameras operating at sixty-four frames per second were used to supplement the high-speed camera with views of the crash from various angles. One of the cameras was equipped with a telephoto lens and was located on the rear quarter of the sign at a considerable distance from the sign. This camera was trained on the sign support during impact and was then "panned" on the crash vehicle throughout its entire movement following impact. The complete system of motion picture cameras provided film that could be used for illustration purposes as well as detailed study of the crash.

DESCRIPTION OF TESTS

Observations will be presented in this preliminary progress report on a series of tests on braced-leg supports and unbraced post supports. It must be emphasized that all of the attempts to record and evaluate data taken in these tests have not been included herein. Also improvements in testing techniques have not been included. For example attempts were made to record and evaluate accelerometer data. The noise level and other technical difficulties have not been overcome at the time of this writing. However, suggestions for improvement of such techniques are under consideration and will hopefully be productive of analytical data. The addition of a timing device which operates synchronously with the high-speed camera is currently in use. This improvement has been a direct result of the testing reported herein. The speed indicated for each test is approximate, and no attempt has been made herein to establish the precision of the reported values. The entire philosophy underlying this initial series of tests has been to ascertain the phenomenological behavior of the structures studied, and to make improvements and modifications thereto.

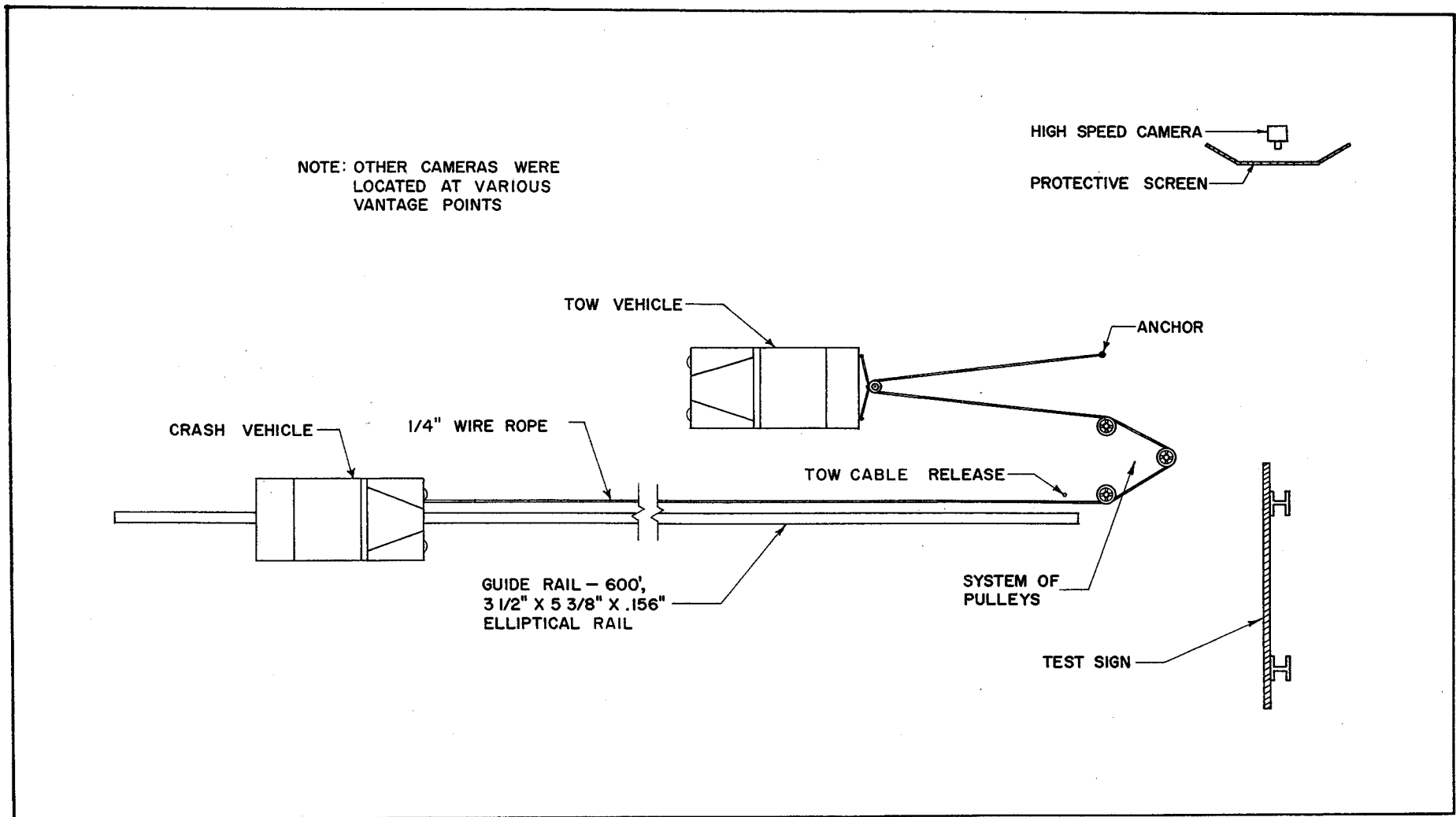

FIGURE I
LAYOUT OF TEST FACILITY

TEST 1

Sign: 8' x 18' plywood background; three supports
Support: Braced-leg structure with cast aluminum fracture joints in members (see Figure 2)
Impact: Left leg- 0 degree angle of incidence
Vehicle: Standard size automobile
Speed: Approximately 55 mph

As indicated above, the first crash test was conducted by striking a braced-leg type support. The support was designed in accordance with AASHQ specifications to withstand a 100 mph wind. Both the leg and the brace were made of steel tubing having an outside diameter of 2-7/8 inches, a wall thickness of 0.083 inches, and a yield strength of 52,000 psi. Details of the design are shown in Figure 2. The objective in this design was to reduce the mass and rigidity required by a single vertical support. It was understandable that the thin wall tubing employed in the design should buckle under the force of the impact, and a cast aluminum fracture joint was placed in each leg and brace at 6-1/2 feet above the foundation to produce impact failure.

A careful study of the high-speed motion picture film of the crash indicated that the vertical leg failed first due to excessive deformation. Next the tubular leg was torn from its base plate, and finally failure occurred at the fracture joint. When failure of the fracture joint occurred it appeared that energy stored in the leg and in the sheet metal of the automobile caused the lower portion of the leg to proceed ahead of the automobile, striking the brace member causing a failure at the fracture joint of the brace prior to impact by the vehicle with the brace. When the vehicle made contact with the brace, the tubing failed due to excessive deformation, and there was a slight tendency for the tube to wrap around the bumper of the vehicle which, in turn, caused a failure at the weld holding the base plate to the lower end of the brace. Both pieces of the support removed by the vehicle were thrown forward in front of the vehicle some distance and were then struck repeatedly by the vehicle. They finally came to rest approximately 250 feet beyond the sign. Sequence photographs of this crash are shown in Figure 3.

Pictorial illustrations of the vehicle before and after impact are shown in Figure 4. From these photographs it is readily evident that the damage resulting from the collision

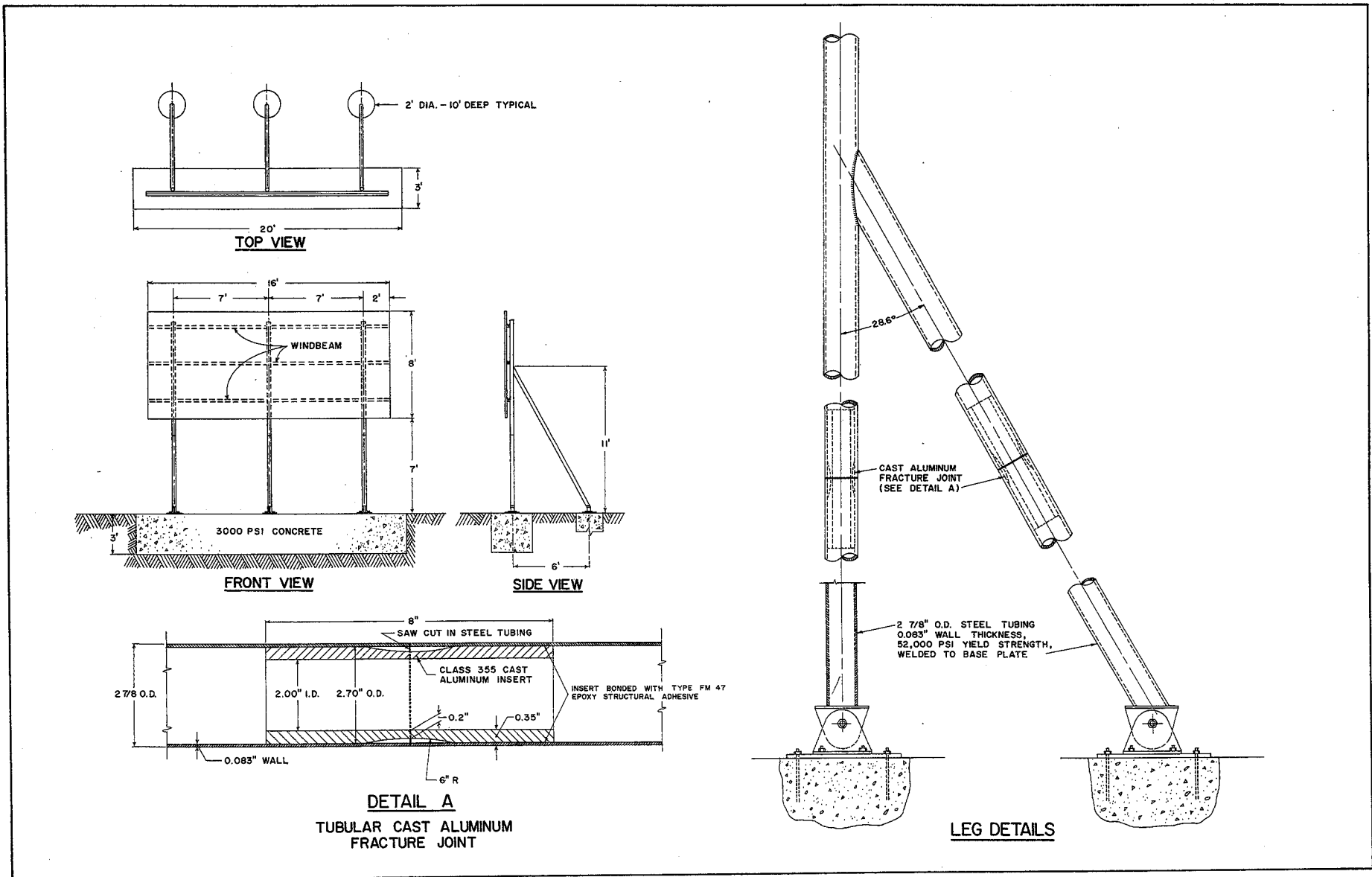
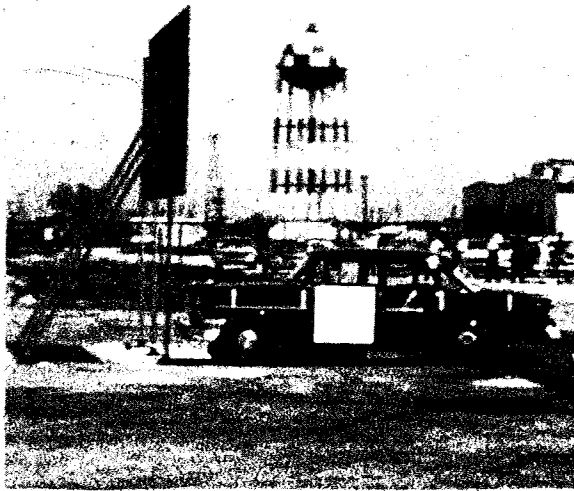
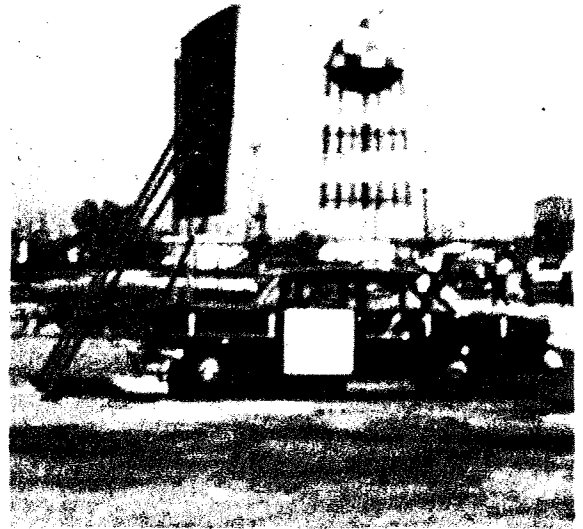

FIGURE 2

GENERAL CONFIGURATION AND DETAILS OF TEST NO. 1



1



2

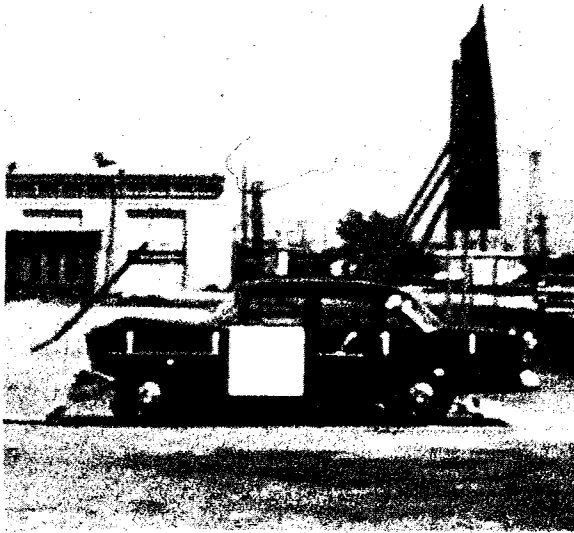

3

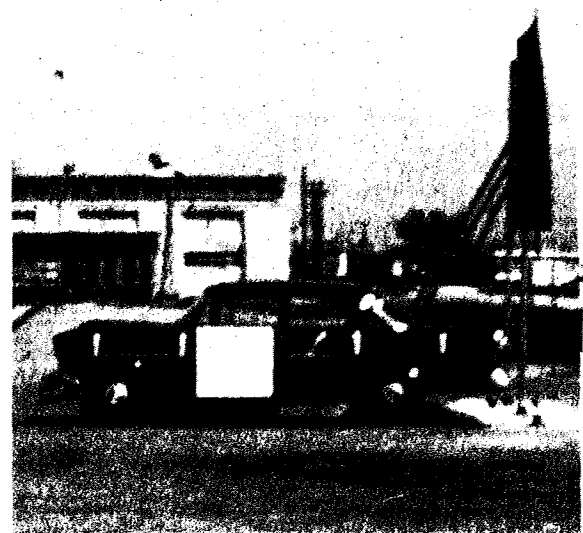

4

FIGURE 3 — SEQUENCE PHOTOGRAPHS TEST NO. 1

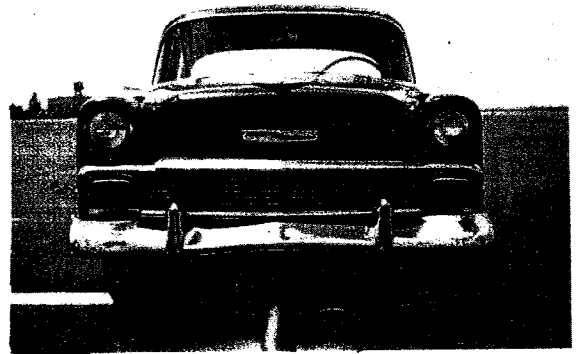
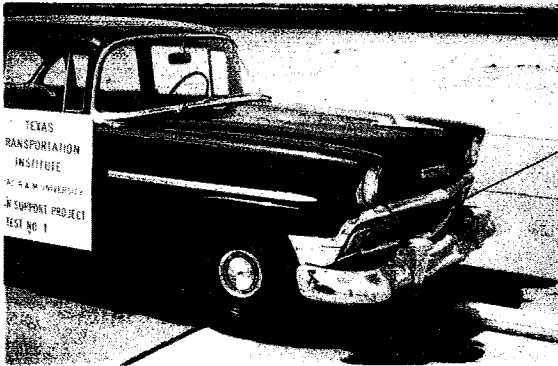

BEFORE

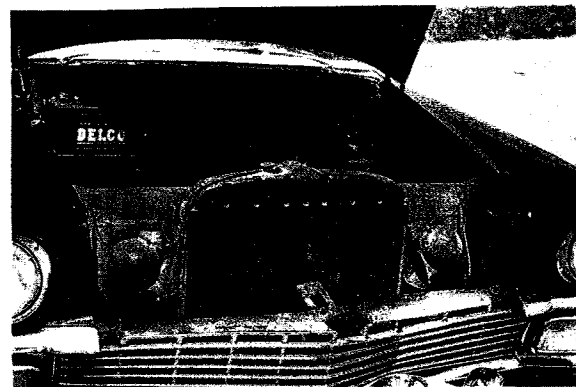
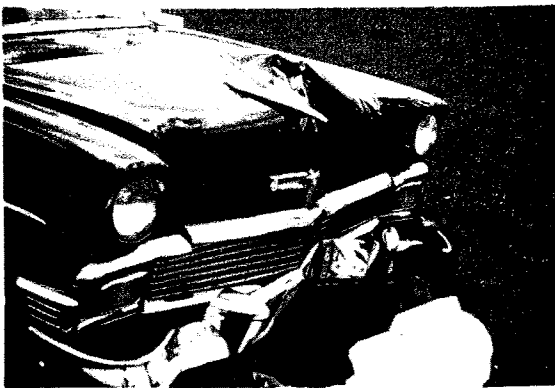

AFTER

FIGURE 4 — VIEWS OF VEHICLE TEST NO. 1

was negligible, especially when considered in terms of personal injury. There was no detectable deceleration of the vehicle due to the impact. Damage was limited to the bumper, gravel shield, grill and hood. The radiator was not damaged nor was it displaced in its harness. It was the general opinion of those observing the crash and the films that the driver possibly could have regained control of the automobile after the crash occurred. The vehicle traveled more than 350 feet following impact.

TEST 2

Sign: 8' x 18' plywood background; three supports
Support: Braced-leg structure with cast aluminum fracture joints in members, reinforced at the base to control failure point (see Figure 5)
Impact: Left leg -0 degree angle of incidence
Vehicle: Standard size automobile
Speed: Approximately 55 mph

The type of sign support used in this test differed from the braced-leg structure in the first test in that the lower section of the legs and the brace were "plugged" with a round steel bar 2-5/8 inches in diameter and 12 inches in length, details of which are shown in Figure 5. This variation in the braced-leg structure was devised in an effort to contain the portion of the support below the fracture joint and prevent it from being thrown through the air like a projectile. The steel plug was inserted in order to strengthen and add mass to the leg and brace at the base plate where failure had occurred in the previous test. This mass below the bumper level would conceivably retain the lower portion of the leg until failure had occurred at the fracture joint and then the vehicle would pass over the lower portions of the support leaving them attached to the foundation.

A study of the high speed motion picture film of this test revealed that the vertical leg failed by excessive deformation due to impact. (Sequence photographs of the crash are shown in Figure 6.) As this failure progressed the aluminum fracture joint insert was pulled out of the upper portion of the vertical leg. There was evidence that the cast aluminum insert used to form the fracture joint was not completely bonded to the inside wall of the tubing. Apparently the amount of epoxy used in bonding the insert was not sufficient to completely fill the space between the cast insert and the inside wall of the tubing. Finally, the brace was torn loose from the foundation due to shearing of the bolt which pinned the brace to the foundation.

Based on general observations of Tests 1 and 2 there was no appreciable improvement in the performance of the braced-leg support modified by strengthening the base connection and adding mass below the bumper level. In fact the damage to the automobile in Test 2 was somewhat more severe than the damage sustained in Test 1, but there was still no detectable deceleration of the

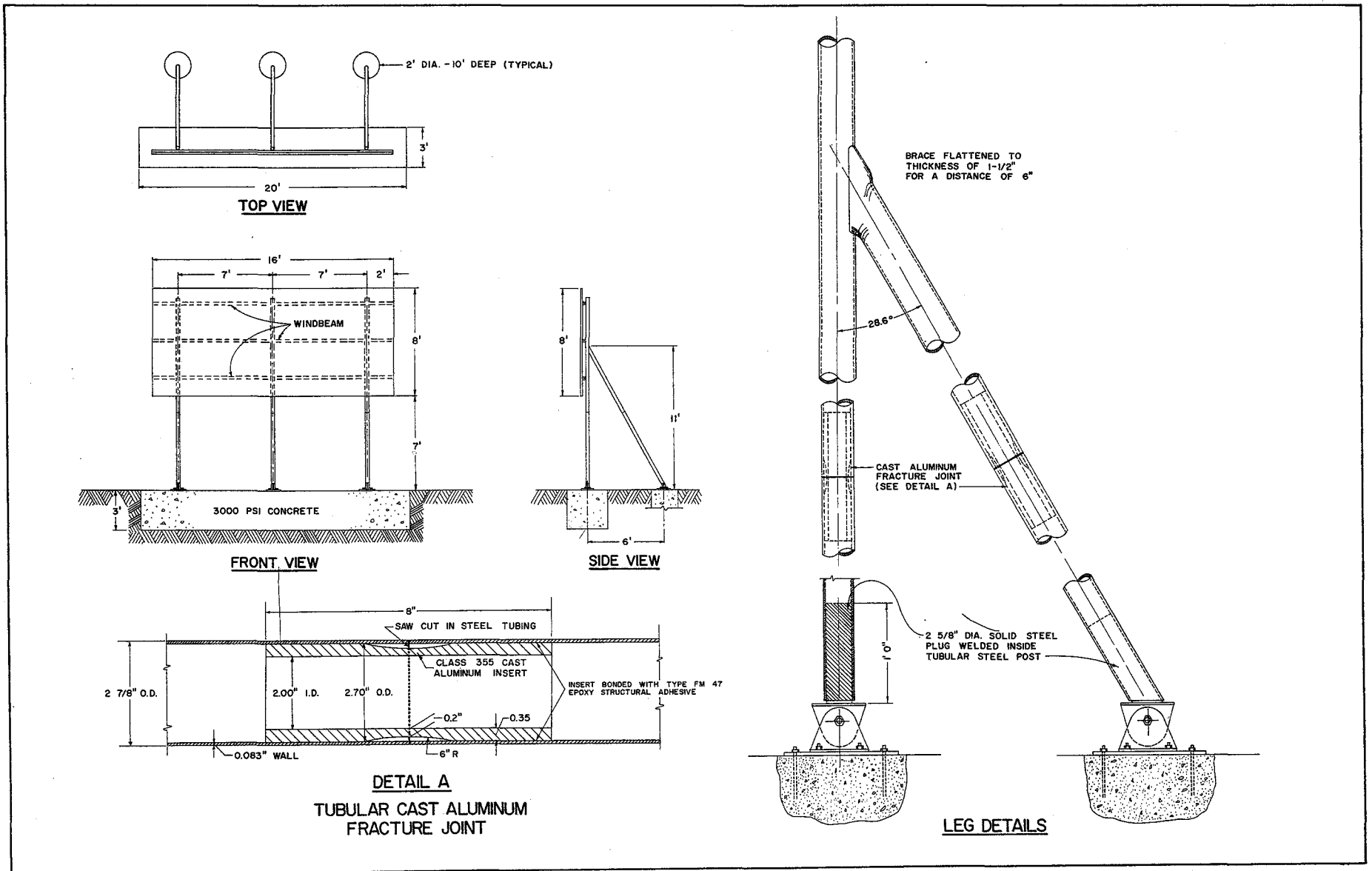
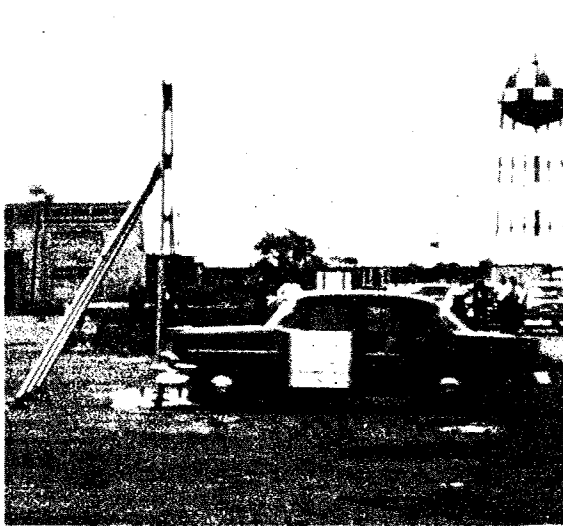
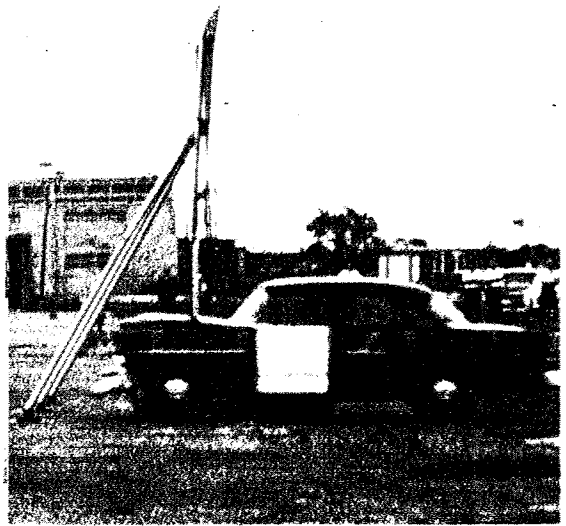

FIGURE 5

GENERAL CONFIGURATION AND DETAILS OF TEST NO. 2



1



2

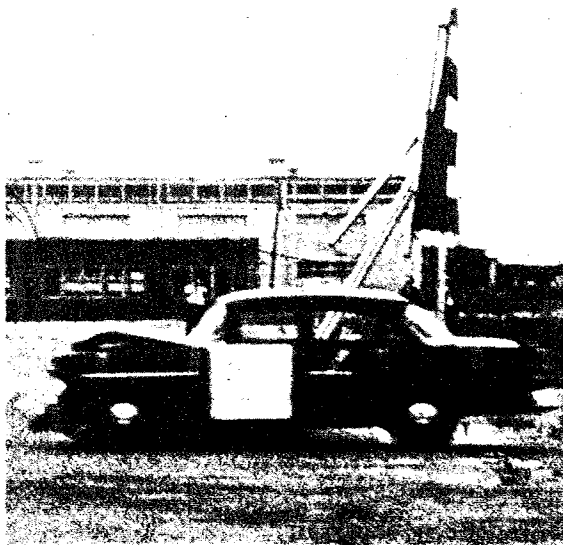

3

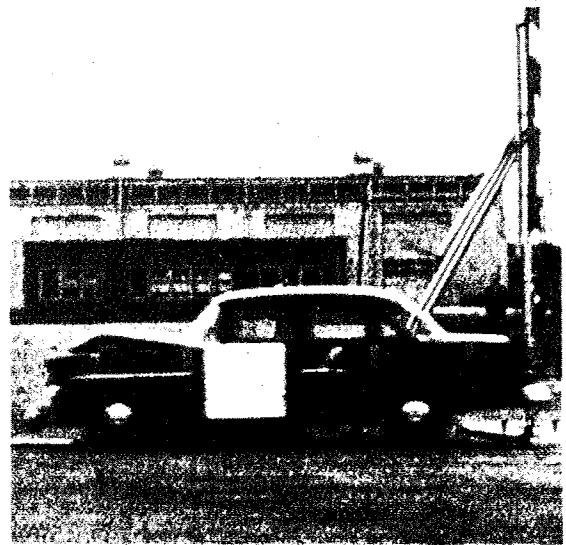

4

FIGURE 6 — SEQUENCE PHOTOGRAPHS TEST NO. 2

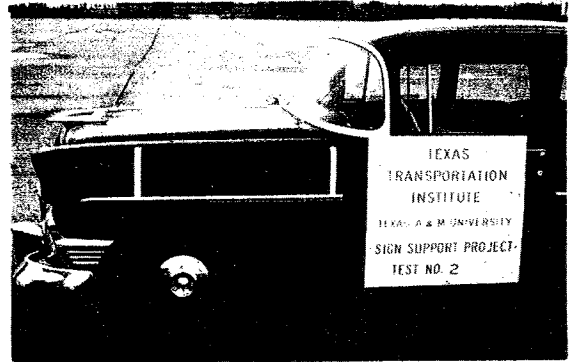

BEFORE

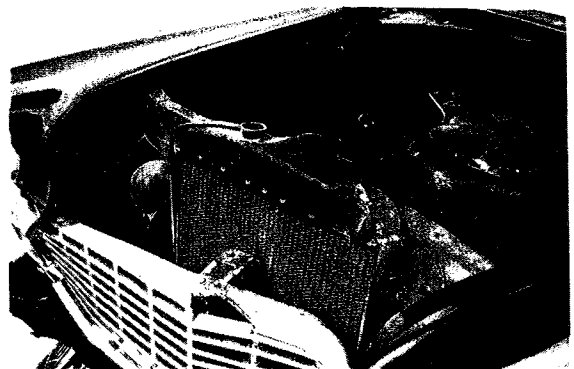
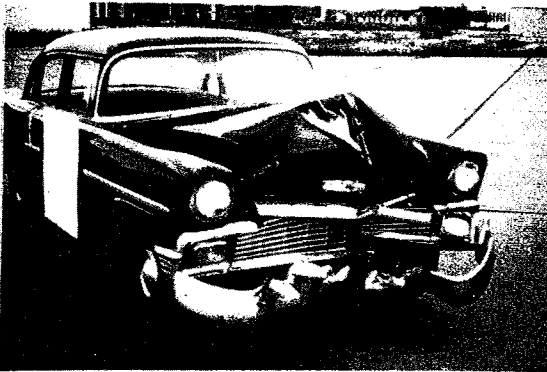

AFTER

FIGURE 7 — VIEWS OF VEHICLE TEST NO. 2

vehicle due to the impact. As the photographs in Figure 7 will indicate the bumper, gravel shield, grill, and hood were damaged more extensively, and the radiator was slightly displaced in its harness. The film showed that this interior damage was caused primarily by the brace rather than the leg of the support. The vehicle traveled more than 350 feet following impact.

TEST 3

Sign: 8' x 18' plywood background; three supports
Support: Braced-leg structure with no fracture joint
(Figure 8)
Impact: Left-leg -0 degree angle of incidence
Vehicle: Standard size automobile
Speed: Approximately 40 mph

Although this was the third in the series of the tests on braced-leg supports, it was a test of the original design concept of the braced-leg structure recommended by the design engineers of the Houston Urban Office.

Observations of the high-speed film showed that the initial impact of the crash vehicle caused excessive deformation in the leg at bumper level. Sequence photographs of this test are shown in Figure 9. As the vehicle continued on through the support the front leg was pulled down causing failure of the bolt connecting the leg and the brace at the top. As the leg was pulled down the two lower cross beams were torn loose from the sign. The lower cross beam struck the windshield of the vehicle shattering the glass, but it did not break through the plastic lamination in the windshield. The front leg separated approximately six feet above ground level as it was being dragged under the vehicle. The brace member which had been freed at the top during the impact was torn loose at the base, and it and the upper portion of the front leg were carried along in front of the vehicle for a considerable distance. There was no perceptible deceleration of the automobile due to impact.

As shown in Figure 10 damage to the vehicle was limited to the bumper, gravel shield, grill, hood, windshield, and top. The vehicle traveled more than 350 feet following impact.

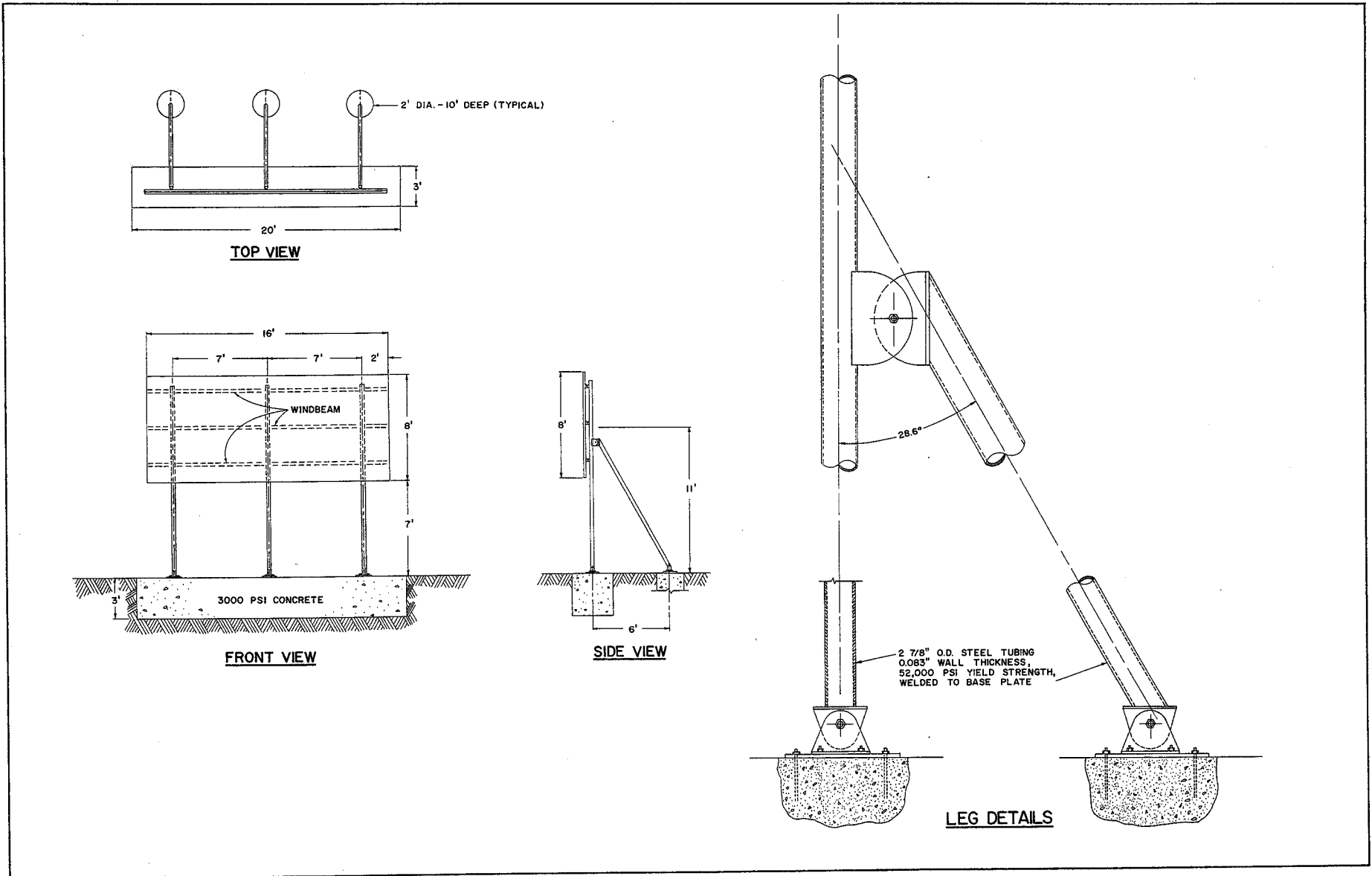
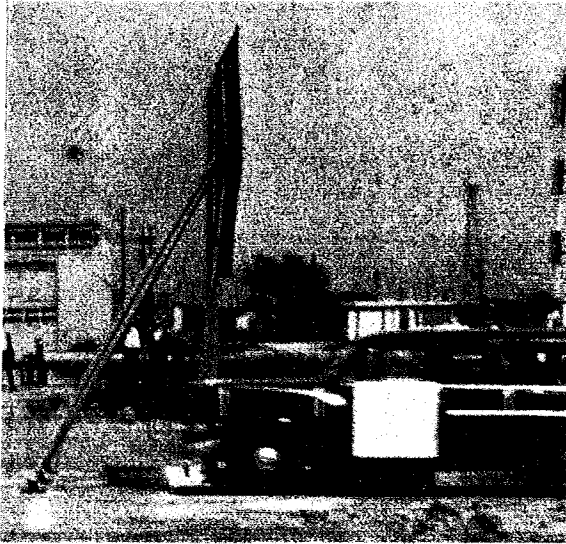
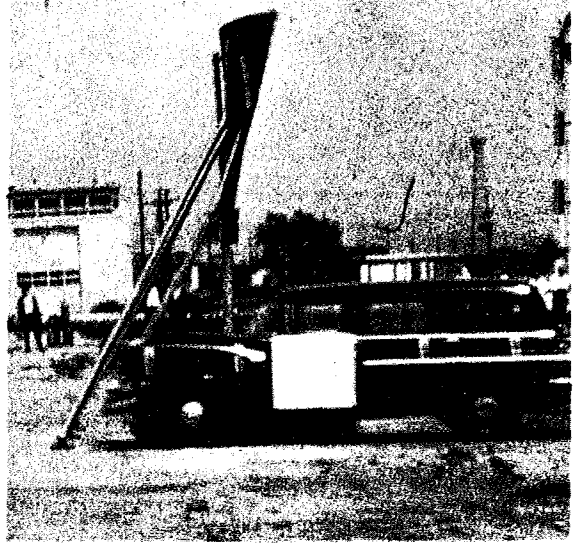

FIGURE 8

GENERAL CONFIGURATION AND DETAILS OF TEST NO. 3



1



2

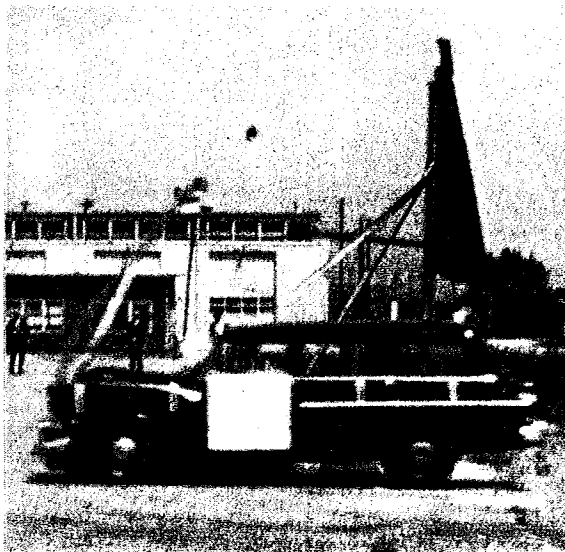

3

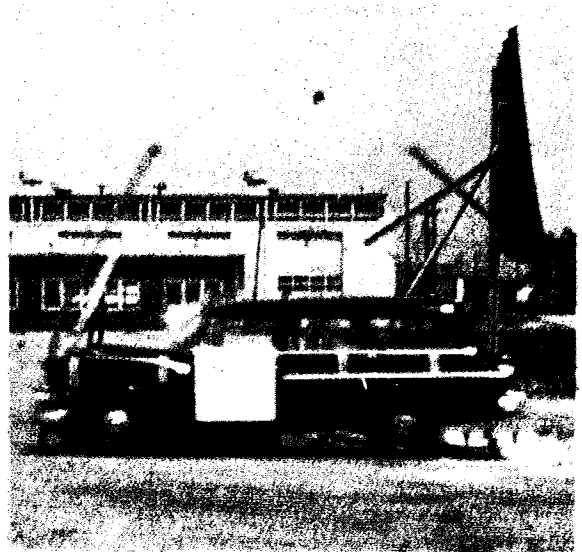

4

FIGURE 9 — SEQUENCE PHOTOGRAPHS TEST NO. 3



BEFORE

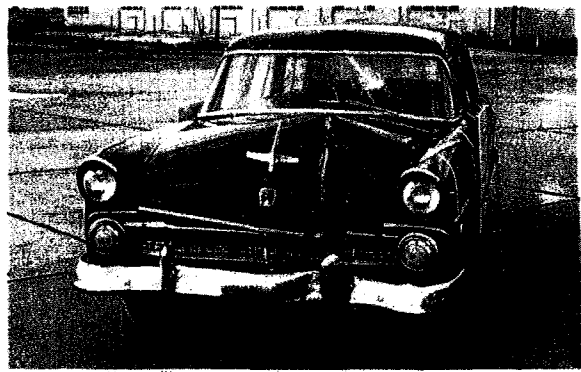

AFTER

FIGURE 10 - VIEWS OF VEHICLES TEST NO. 3

TEST 4

Sign: 8' x 18' plywood background; two supports
Support: Unbraced post; 8WF31 steel beam with slip joint at base (Figure 11).
Impact: Left leg - 0 degree angle of incidence
Vehicle: Standard size automobile
Speed: Approximately 55 mph

This particular design, which was proposed by engineers of the Bridge Division of the Texas Highway Department, makes use of a release mechanism at the base of the post replacing the rigid connection currently used in practice. It must be emphasized that the 8WF31 steel beam section employed in this test was larger than would normally be required for an 8'x18' sign installed in the field. This particular size was selected as representative of the large sign supports currently used in practice. The release mechanism is termed a "slip joint" and is shown in detail in Figure 11. Upon impact the post was intended to be released due to sliding action permitted by the slots in the foundation and the base plate of the post. As shown in Figure 11, a steel plate was welded to the web of the post and permitted to extend alongside but not attached to the web of the foundation. This extended plate was intended to cause the sign post to rotate forward so the vehicle would pass over it.

When impact occurred the slip joint behaved as expected but the plate extending alongside the web of the base served as a secondary restraint. The crash vehicle traveled 9 inches between initial impact and the time slippage occurred at the base. However, the vehicle traveled an additional 27 inches before the extension plate on the web of the post was raised above the foundation fitting. The inertia effects of the large mass above the bumper level and ambient air resistance on the sign were too great to allow forward rotation prior to movement of the extension plate. The upper portion of the post penetrated inside the left frame member of the vehicle to the left of the engine for a distance of approximately 3 feet. While this destruction was occurring the vehicle was decelerating rapidly and beginning to pitch and skid to the right. (Sequence photographs are shown in Figure 12). Finally the extension plate on the post was lifted above the foundation and the vehicle passed on under the post a distance of 63 feet beyond the sign. The front wheels were damaged to the extent that the left front wheel was restrained and the vehicle skidded to a stop. It should also be noted that the base plate of the foundation was not precisely horizontal and had to

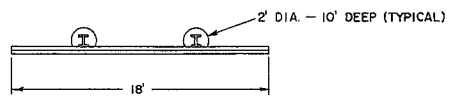

TOP VIEW

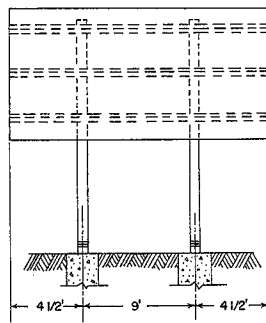

FRONT VIEW

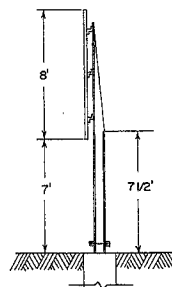

SIDE VIEW

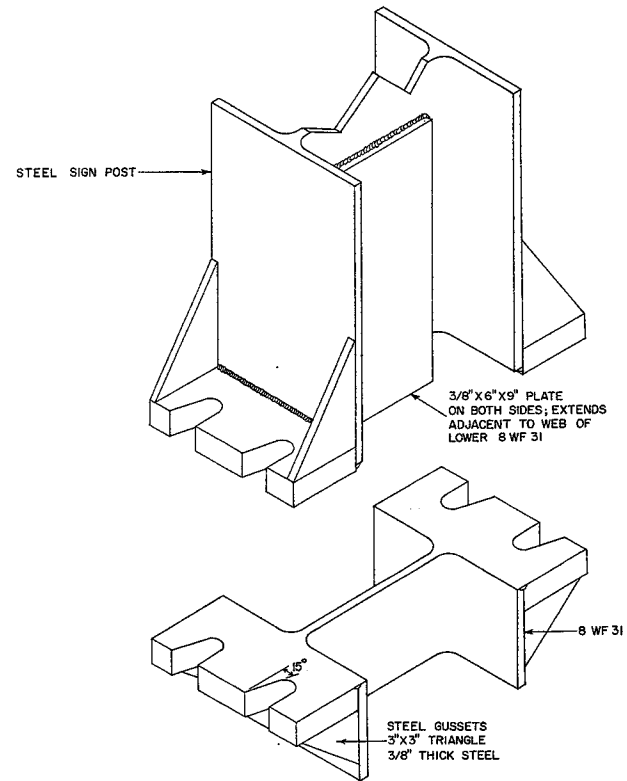

**BASE DETAIL AT
JUNCTURE WITH POST**

FIGURE 11

GENERAL CONFIGURATION AND DETAILS OF TEST NO. 4

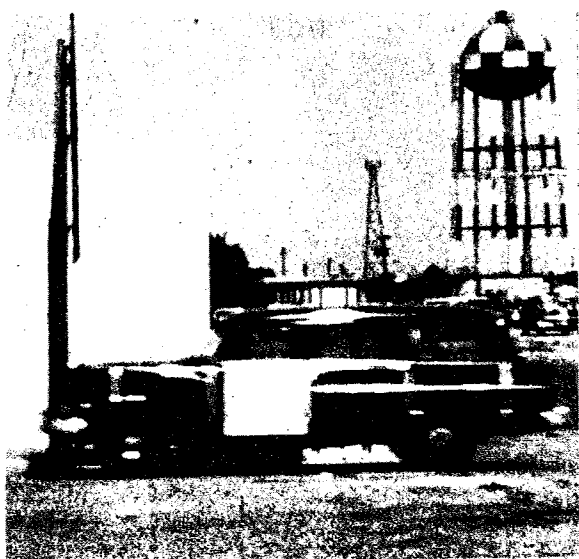

1

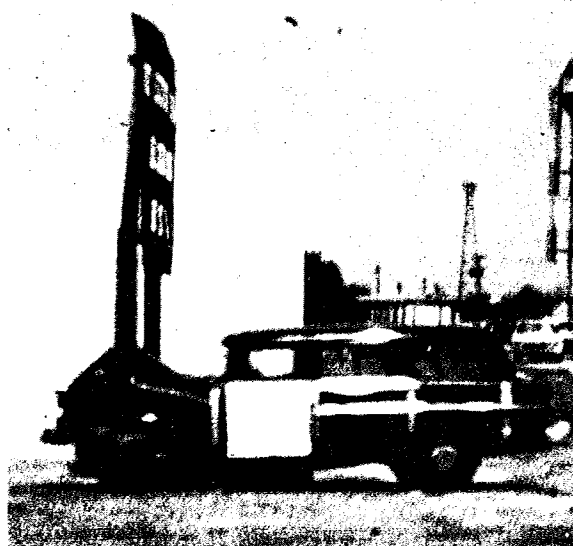

2

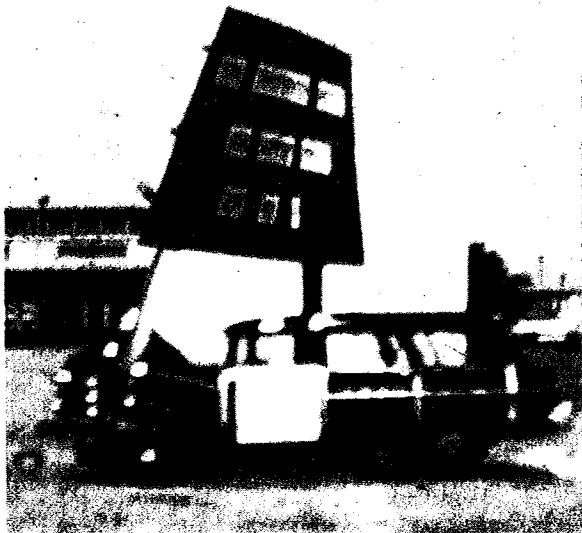

3

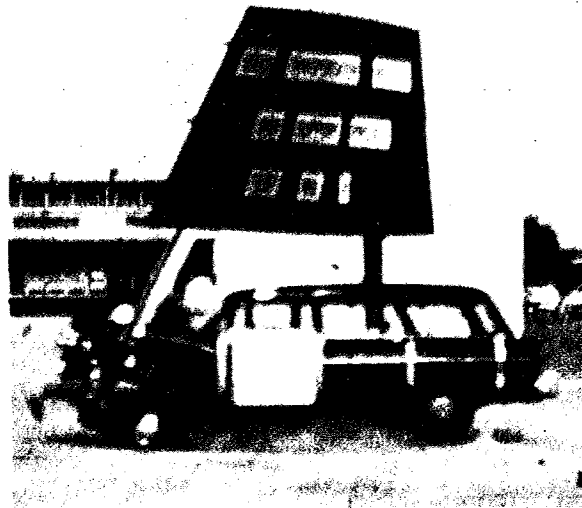

4

FIGURE 12 — SEQUENCE PHOTOGRAPHS TEST NO. 4

be altered for a subsequent test. As the vehicle passed under the post, the base plate of the post tore the hood loose, penetrated the windshield in front of the driver's seat, and caused considerable damage to the front portion of the top of the vehicle. This particular variation was by no means satisfactory, and further modifications were proposed by engineers of the Bridge Division. Most observers conjectured that the severity of the impact and the damage due to the post striking the windshield and passenger area would probably have resulted in serious injury or possibly a fatality. Before and after views of the sign and the test vehicle are shown in Figure 13.

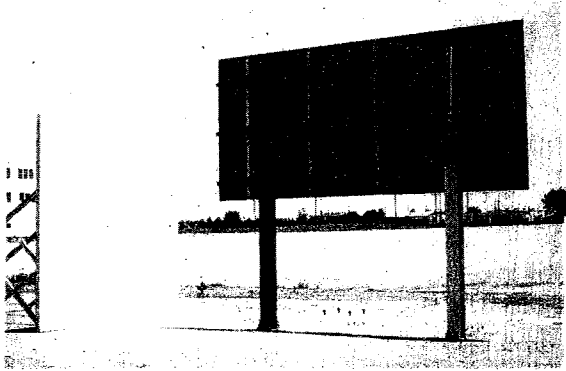

BEFORE

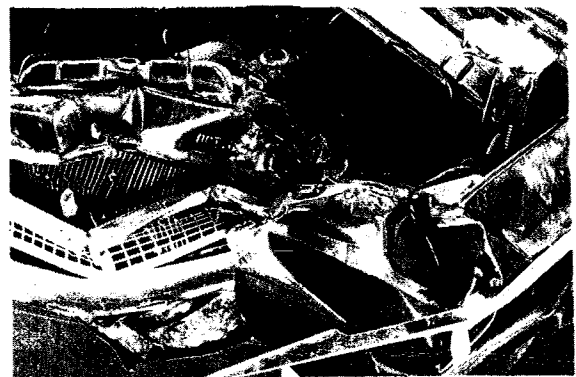
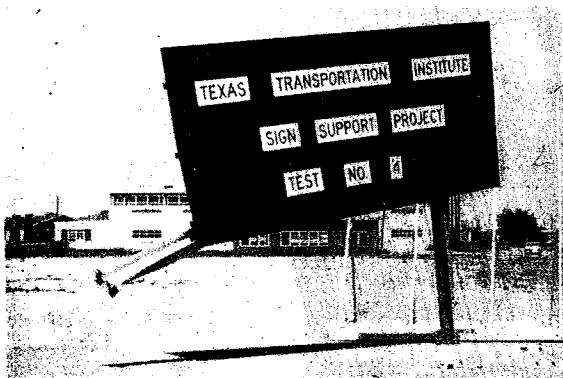
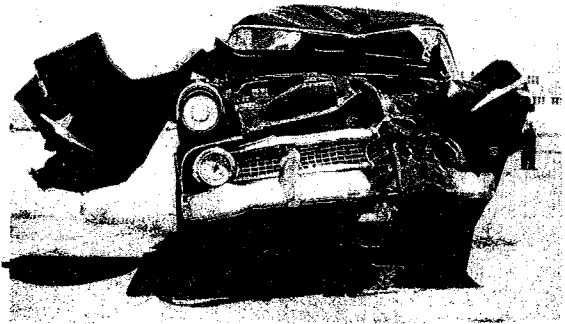

AFTER

FIGURE 13 — VIEWS OF VEHICLE AND SIGN TEST NO. 4

TEST 5

Sign: None
Support: Unbraced post: free-standing 7-foot
section of 8WF31 steel beam with base
plate.
Impact: 0 degrees angle of incidence
Vehicle: Standard size automobile
Speed: Approximately 55 mph

Test 5 was conducted to evaluate the inertial effects of a section of the unbraced post support which could conceivably be removed by the impact of collision. To facilitate this test a 227-pound, seven-foot section of the same post used in Test 4 was erected in a free-standing position on its foundation. It was not bolted or fastened to the foundation in any way. The sequence photographs in Figure 14 show the results of this test. As shown in Figure 15 the damage of the vehicle due to initial impact was limited mainly to sheet metal parts. The major damage to the vehicle was caused by the behavior of the free-standing beam which rotated end over end, striking the hood and windshield first, and then striking the rear of the vehicle, breaking the rear windshield. (See Figure 14). Observation of the behavior of this free-standing beam suggested that the effect of the mass of this type of support is sufficiently small to permit the accomplishment of an effective break-away design. The vehicle traveled more than 350 feet following impact.

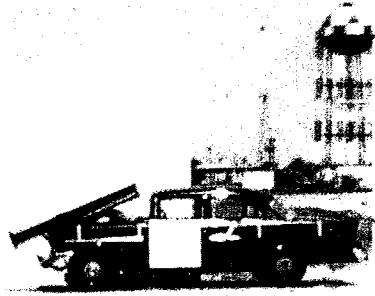

1



2

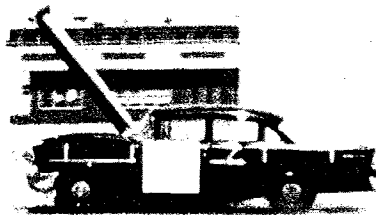

3

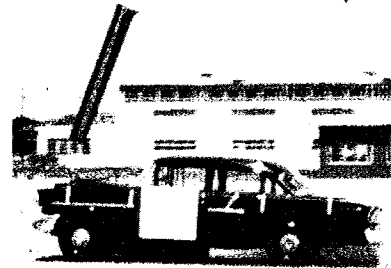

4



5

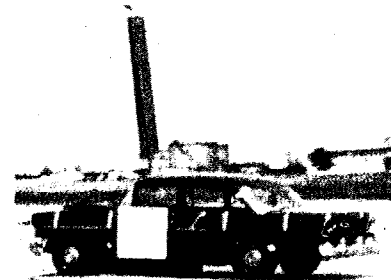

6

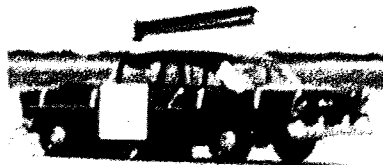

7



8

FIGURE 14 — SEQUENCE PHOTOGRAPHS TEST NO. 5

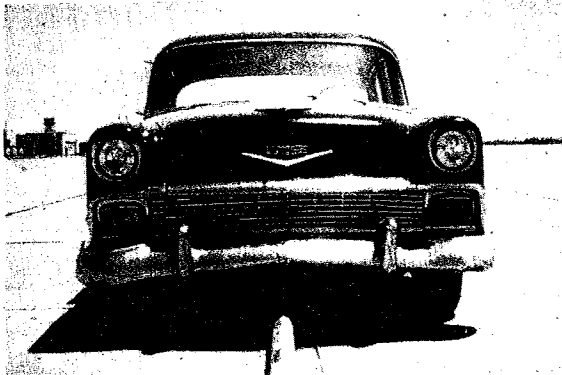

BEFORE

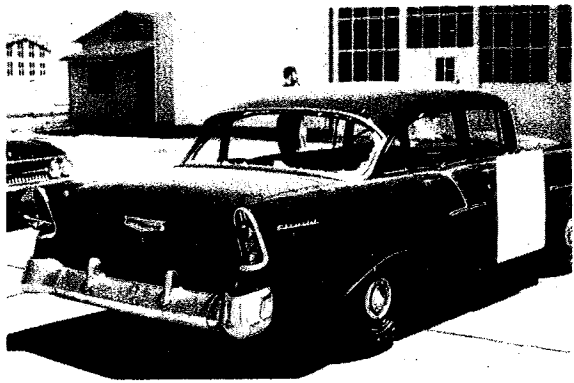

AFTER

FIGURE 15 — VIEWS OF VEHICLE TEST NO. 5

TESTS 6 & 7

Sign: 8' x 18' background; two supports
Support: Unbraced post; 8WF11.5 aluminum beam
with slip joint at base (Figure 16)
Impact: Left leg - 0 degree angle of incidence
Vehicle: Standard size automobile
Speed: Approximately 55 mph

Test 6 was conducted to evaluate the application of aluminum in the construction of the unbraced post support for the purpose of reducing the mass of the support. The details of this design are shown in Figure 16. To satisfy strength requirements the web of the lower portion of each of the aluminum posts was sawed, the flanges were spread to 10 inches at the base, and the web was again joined with cover plates on each side. The use of aluminum in this post permitted a weight reduction by a factor of approximately 3.

When the vehicle struck the post (see Figure 17) the slip joint at the base functioned as expected and the post rotated upward clearing the vehicle. Several of the aluminum welds failed and the sign completely collapsed. It was apparent that the welds were of poor quality and observations drawn from the test could not be considered reliable. Before and after views of the impact, post, and vehicle are shown in Figure 18.

The posts were repaired and steps were taken to obtain high quality welds during fabrication. The test was re-run as Test 7 with very similar results. Only minor damage to the sheet metal on the front of the vehicle was incurred in causing the post to release at the base. And there was no perceptible deceleration of the vehicle due to impact. Once the post was released the base rotated upward clearing the vehicle as it passed under the sign. The impact caused the sign to rotate extensively about the right post but this was not sufficient to cause failure in the right post. In each of tests 6 and 7 the vehicle traveled more than 350 feet following impact.

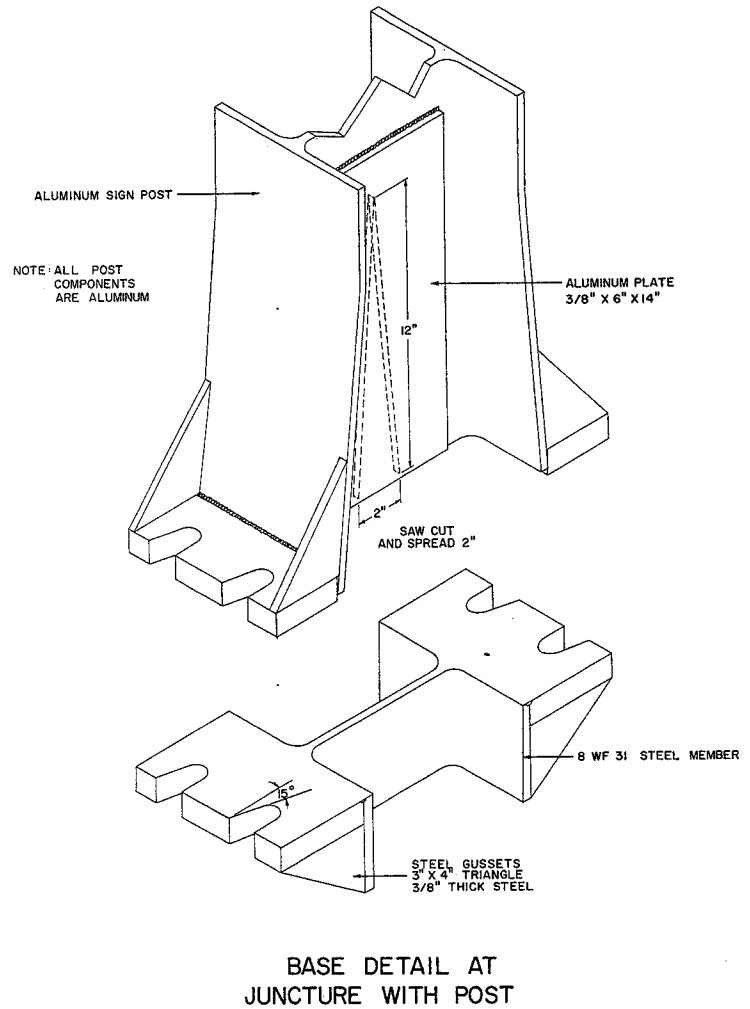
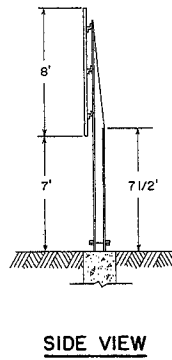
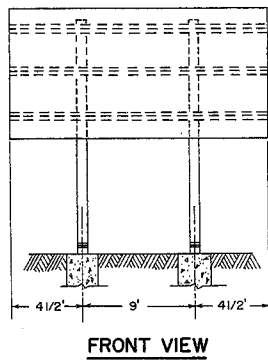
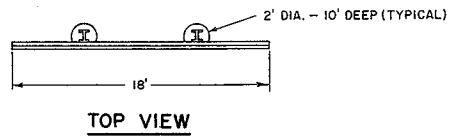
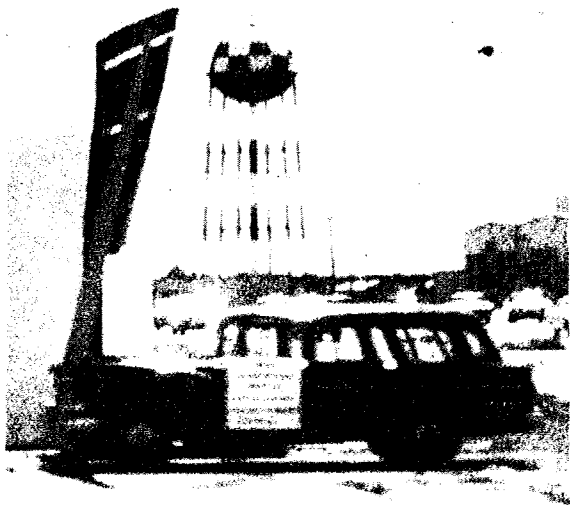
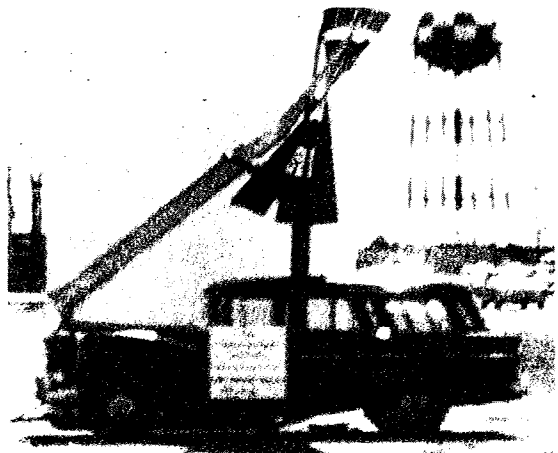

FIGURE 16

GENERAL CONFIGURATION AND DETAILS OF TEST NO's 6 & 7



1



2



3

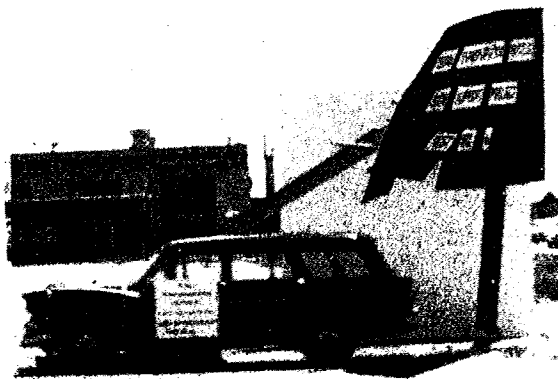

4

FIGURE 17 — SEQUENCE PHOTOGRAPH TEST NO. 6

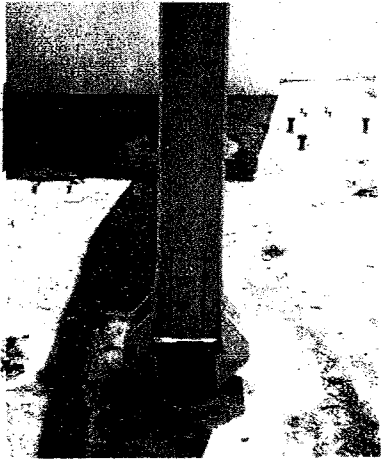

BEFORE

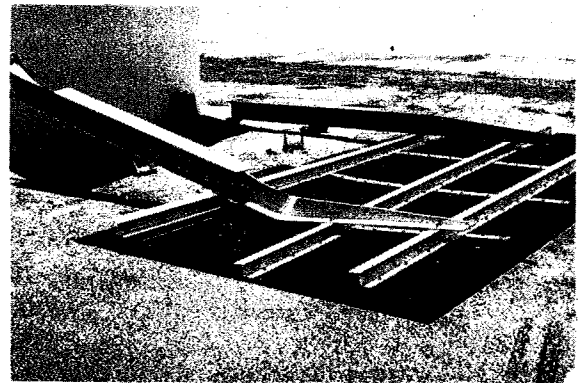

AFTER

FIGURE 18 - VIEWS OF VEHICLES AND SIGN TEST NO. 6

TEST 8

Sign: 8' x 18' plywood background; two supports
Support: Unbraced post; 8WF31 steel beam with slip joint at base and fracture joint 7 feet above ground level (Figure 19)
Impact: Left leg - 0 degree angle of incidence
Vehicle: Standard size automobile
Speed: Approximately 55 mph

In Test 8 steps were taken to correct the undesirable characteristics of the unbraced post support noted in Test 4. The details of this design are shown in Figure 19. It should be noted that the slip joint at the base was improved by removing extension plates from the web of the post, and a "fracture joint" was introduced in the post at a point 7 feet above the ground level. This fracture joint was formed by cutting the post completely through and rejoining the abutting portions with two cast iron plates bolted to the front and back flanges. This feature was introduced in an effort to eliminate the possibility of the base of the post striking the windshield and passenger space as described in Test 4.

From the high-speed film it was observed that the vehicle traveled approximately 9 inches, deforming the front bumper and related parts, between the time of initial impact and the time slippage occurred at the base of the post. Immediately after slippage occurred the fracture joint failed freeing the lower section of the post as shown in Figure 20. This lower section of the post then pierced the windshield, struck the dashboard, and vaulted over the top of the automobile, slightly puncturing the roof of the automobile near the left rear corner.

The before and after pictures in Figure 20A show that damage due to the initial impact was relatively minor when compared to photos of the vehicle used in Test 4 (see Figure 13). The vehicle traveled more than 350 feet after impact. Therefore, it was assumed that personal injury would probably be limited to minor cuts due to broken glass. However, the fact that the post penetrated the windshield is an indication that considerably greater injury could have resulted under other circumstances. As a result of these observations it was decided that the fracture joint was somewhat less than satisfactory. The fact that the lower section of the post could not be controlled after its release made it an extremely hazardous flying object.

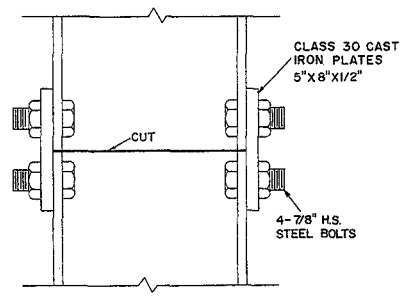
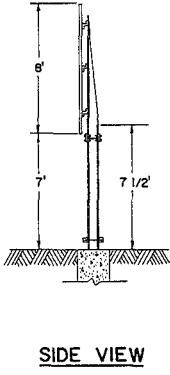
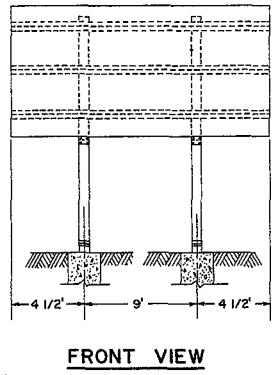
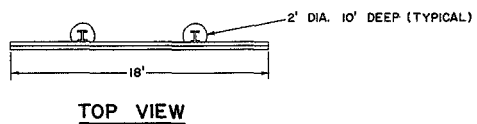

FRACTURE JOINT
 POST CUT COMPLETELY THROUGH
 AND REJOINED WITH CAST IRON PLATES

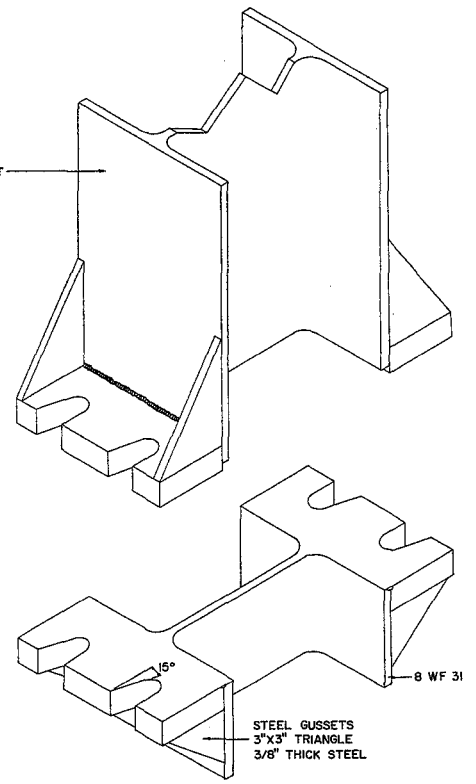

**BASE DETAIL AT
 JUNCTURE WITH POST**

FIGURE 19

GENERAL CONFIGURATION AND DETAILS OF TEST NO. 8

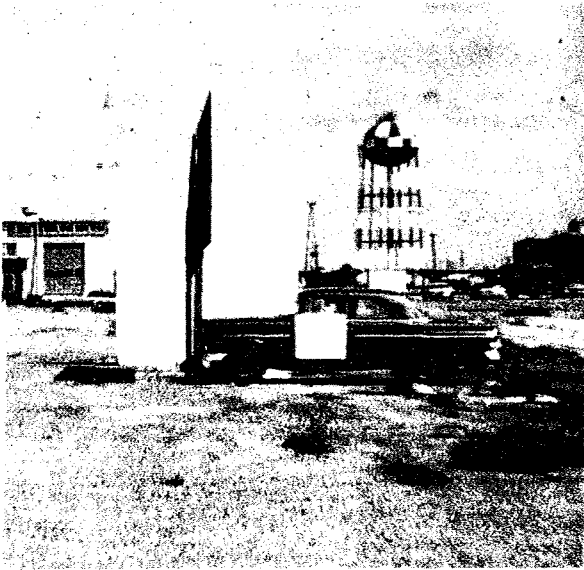

1

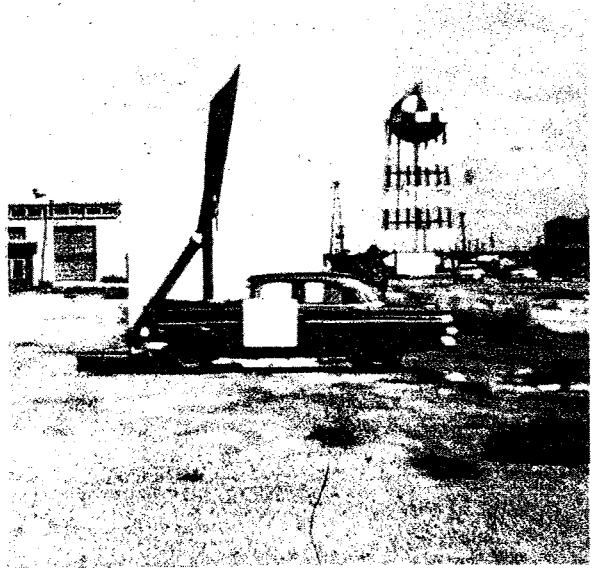

2

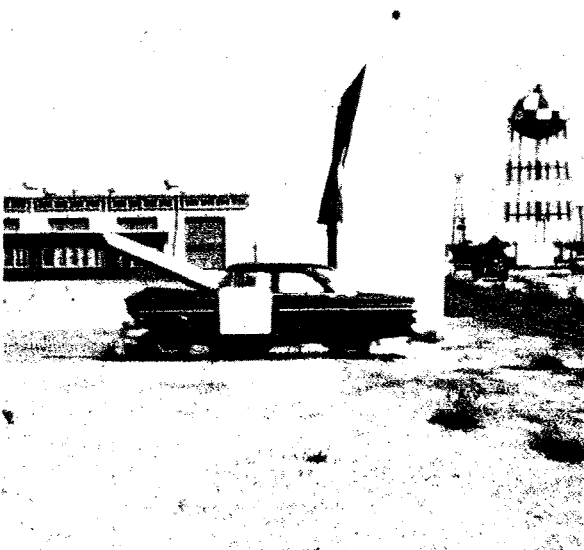

3



4

FIGURE 20 - SEQUENCE PHOTOGRAPHS TEST NO.8

TEST 9

Sign: 8' x 18' plywood background; two supports
Support: Unbraced post; 8WF31 steel beam with slip joint at base and "hinge" joint 7 feet above ground level (Figure 21)
Impact: Left leg - 0 degree angle of incidence
Vehicle: Standard size automobile
Speed: Approximately 25 mph

The problem encountered with the unbraced post support in Test 8 suggested devising some means of controlling the lower section of the post after its release at the base due to impact. To correct this problem a "hinge" joint was introduced in the place of the fracture joint described in Test 8. As shown in Figure 21 this hinge was formed by cutting the front flange and the web of the post at a height of 7 feet above the ground level. The front flange was then rejoined across the cut using a cast iron plate bolted to the flange. The back flange was left intact to serve as the "hinge".

In the collision (see Figure 22) the vehicle traveled approximately 7 inches between the time of initial contact with the post and the time slippage occurred at the base. The bumper and sheet metal components were deformed in the process. Before and after pictures of the vehicle were not available for this test. The same unrepaired vehicle from Test 8 was used and some permanent deformation of the sheet metal parts was evident prior to the test as shown in Figure 20A. This permanent deformation changed the resiliency of the front of the vehicle, accounting for a reduction in deformation of vehicle on impact.

When the base had slipped free the post rotated through an angle of approximately 45 degrees before the fracture plate failed. At that point the plate failed across the bolt holes and the lower section of the beam rotated upward through an angle of roughly 120 degrees from its original position and completely cleared the top of the automobile.

The crash vehicle traveled more than 300 feet and came to rest in a drainage ditch after impact. This fact alone indicated that the resistance of the post to impact was relatively low.

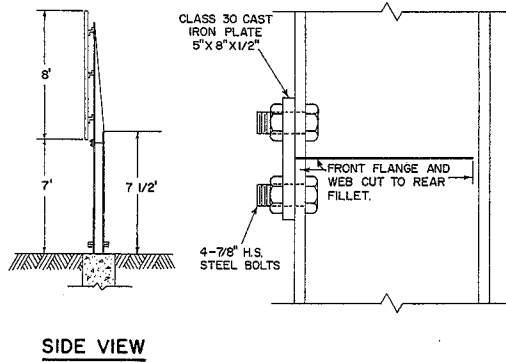
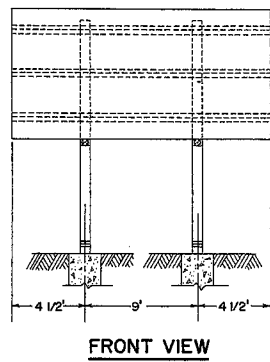
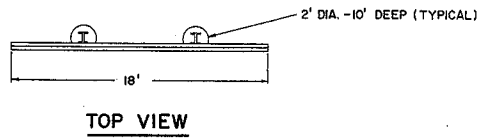

"PLASTIC HINGE" JOINT
POST CUT AS SHOWN AND REJOINED WITH CAST IRON PLATE. BACK FLANGE PROVIDES "PLASTIC HINGE".

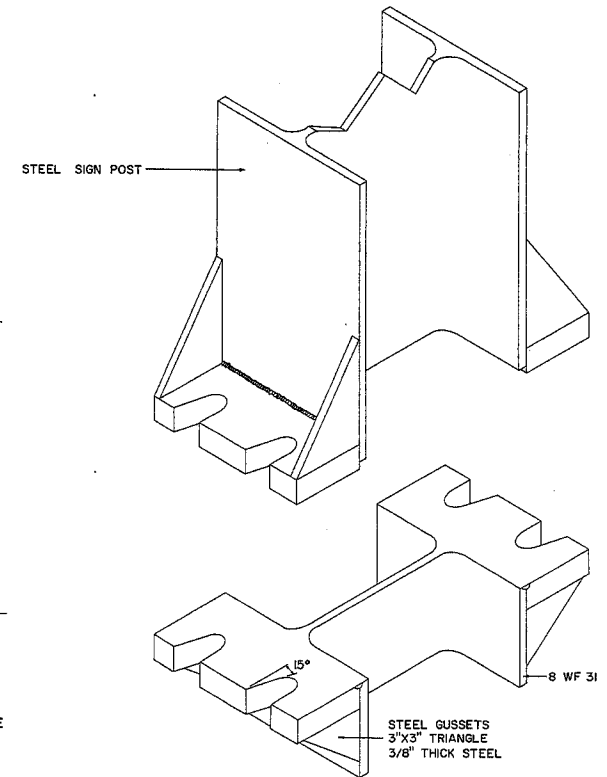

BASE DETAIL AT
JUNCTURE WITH POST

FIGURE 21

GENERAL CONFIGURATION AND DETAILS OF TEST NO's. 9,10,&13

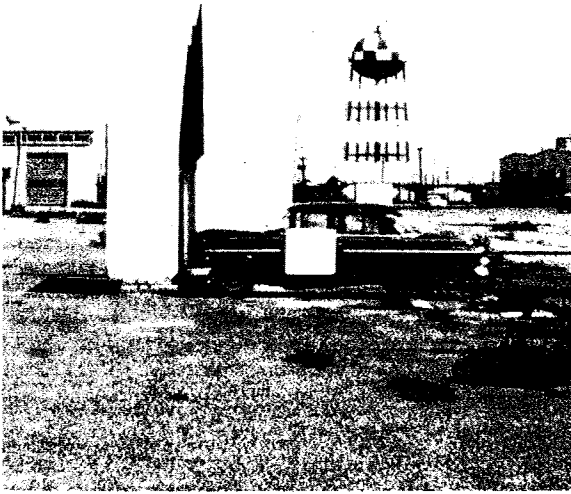

1

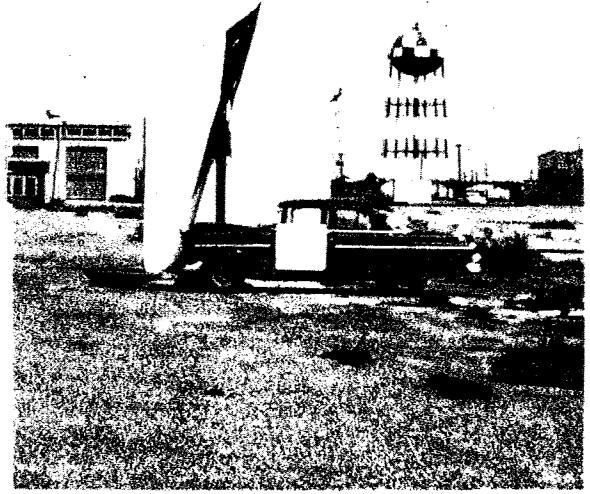

2

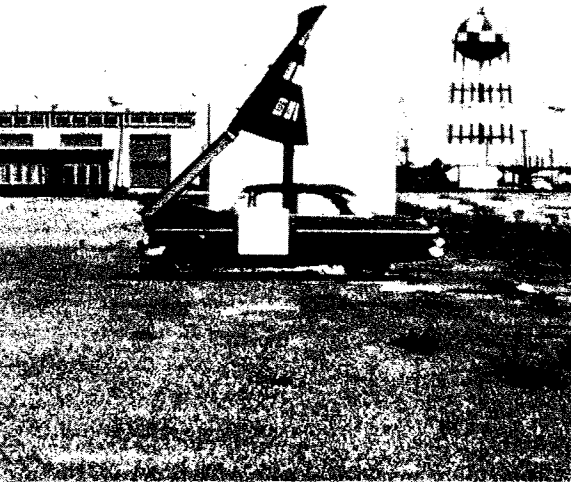

3

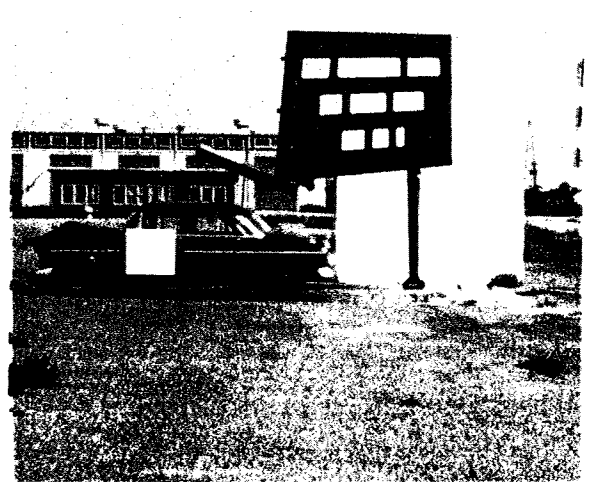

4

FIGURE 22 - SEQUENCE PHOTOGRAPHS TEST NO. 9

TEST 10

Sign: 8' x 18' plywood background; two supports
Support: Unbraced post; 8WF31 steel beam with slip joint at base and "hinge" joint 7 feet above ground level (Figure 21)
Impact: Left leg - 0 degree angle of incidence
Vehicle: Standard size automobile
Speed: Approximately 50 mph

This test was conducted to determine the effect of higher speed on the behavior of the slip joint and hinge features. Sequence photographs are shown in Figure 23.

Films of the crash showed that the vehicle traveled approximately 5 inches, deforming the front bumper and sheet metal, between the time of initial contact and the time slippage occurred at the base. Immediately after slippage occurred at the base the fracture plate on the front flange failed and the back flange performed as a hinge. The post rotated upward twisting the sign face through an angle of approximately 40 degrees from its original position. At that point the post pulled loose from the cross beams on the sign and the entire post rotated about its upper end. After the vehicle had passed under the sign the post came to rest on the ground immediately behind the sign. The reaction was considerably more violent than in the slow-speed test, but there was very little difference in damage sustained by the vehicle. The damage was limited to the bumper, grill, hood, and associated parts. (See before and after pictures in Figure 23A.)

There was very little apparent deceleration of the vehicle due to the impact. The vehicle traveled more than 350 feet and crossed a drainage ditch after impact.

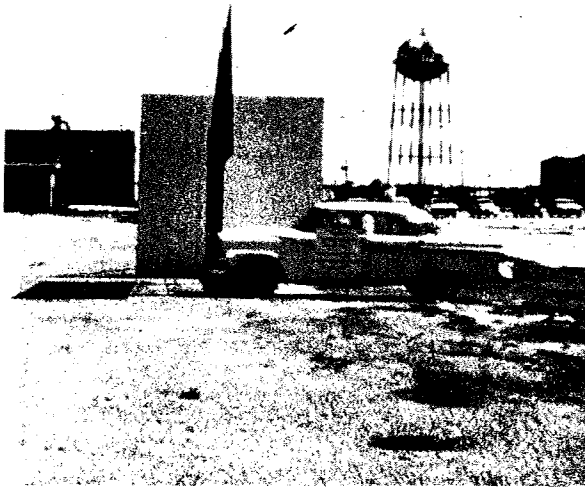

1

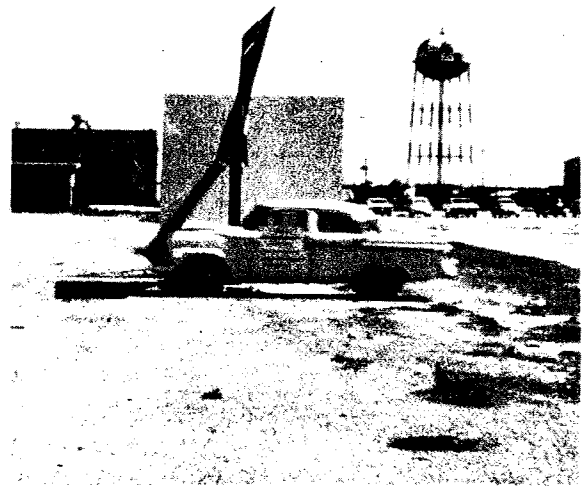

2

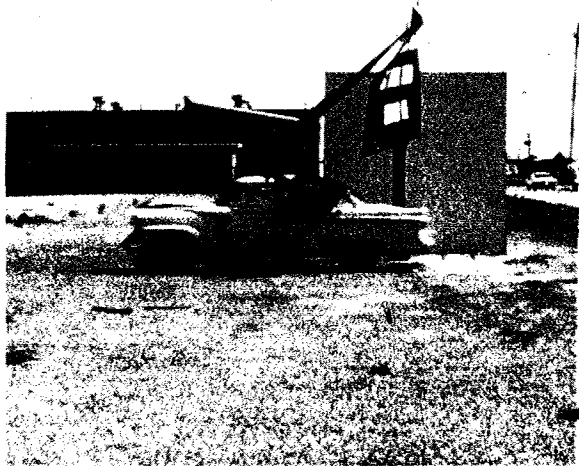

3

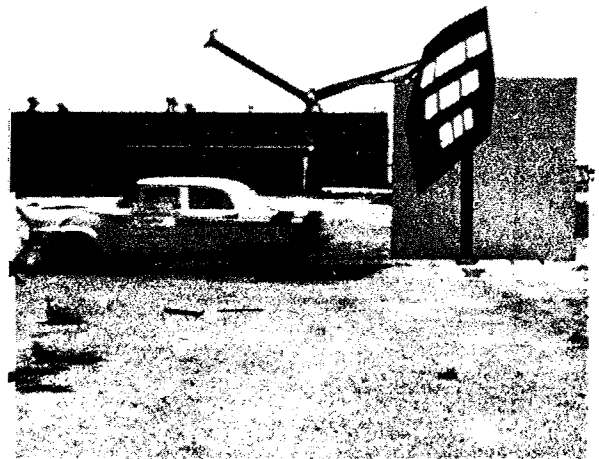

4

FIGURE 23 - SEQUENCE PHOTOGRAPHS TEST NO.10

TEST 11

Sign: 10' x 16' Extruded aluminum background;
two supports
Support: Braced-leg type aluminum structure (see
photographs in Figure 24)
Impact: Left leg - 0 degree angle of incidence
Vehicle: Standard size automobile
Speed: Approximately 55 mph

The aluminum structure used in this test was similar only in general configuration to the braced-leg structures used in Tests 1, 2, and 3 (Figure 24). The vertical leg member to which the sign was attached was an aluminum "T-section" 17 feet in length. This T-section was welded to an aluminum base plate which was rigidly bolted to the foundation. The brace member of the support consisted of tubular aluminum welded into the configuration shown in Figure 24. The brace member was bolted securely to a rear foundation. Lateral support was provided by a diagonal brace between the two supports.

Aluminum welding was used extensively in the construction of the sign support. Based on this observation, the sign support was presumed to be rather costly, even under circumstances where assembly line production methods might be employed. No information was available on cost of materials and fabrication because the support was designed and fabricated by one of the aluminum companies.

A power failure which occurred while the test was in progress stopped the high-speed camera, and consequently, that film was not available for detailed observation. Films from the other camera provided limited observation of the crash. Sequence photographs are shown in Figure 25. The front leg failed under the initial impact due to separation at the base plate. Later observation of the failure led the investigators to believe that the weld was inferior. The two members of the brace-leg were torn off immediately above welds reinforcing the connection of the members to the base plate.

There was very little damage to the vehicle, but the sign background and supports were damaged extensively. The vehicle traveled more than 350 feet after impact.

TEST 12 NOT INCLUDED BECAUSE IT WAS THE FIRST OF A
SERIES OF TESTS ON SMALL SIGNS NOT YET COMPLETED.

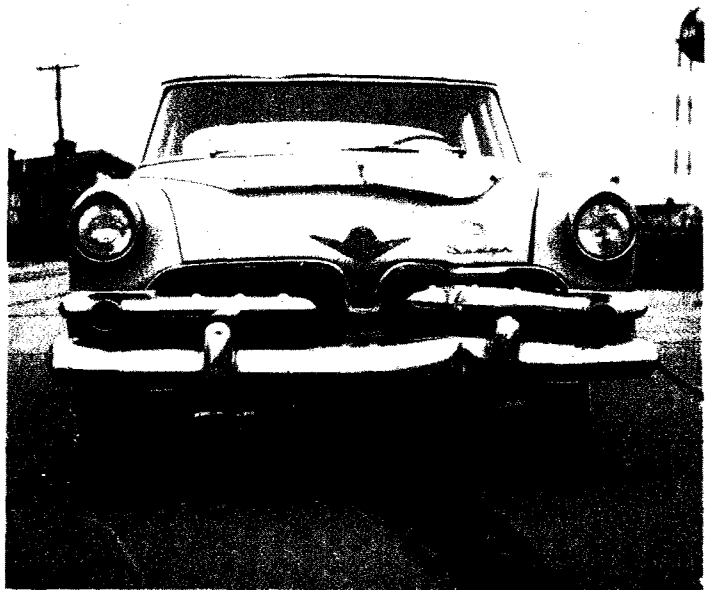
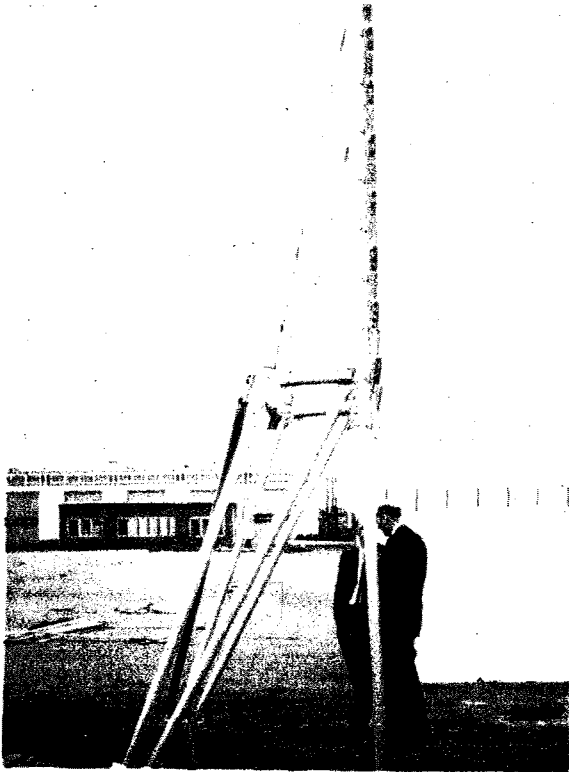
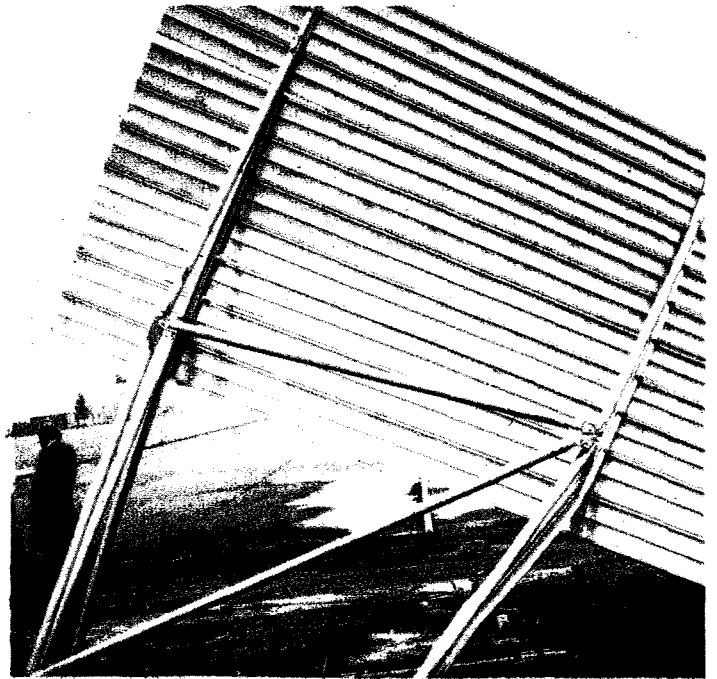
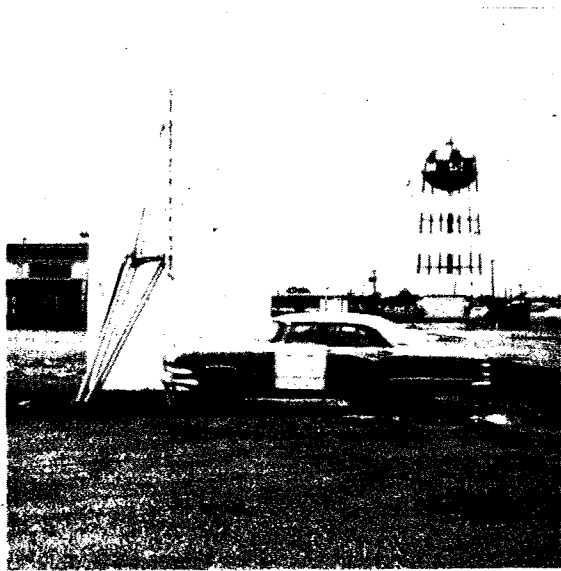
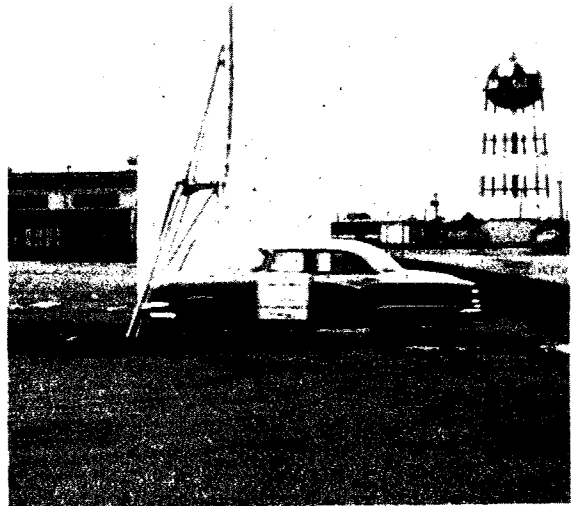

FIGURE 24 - DESIGN FEATURES, SIGN AND VEHICLE DAMAGE TEST NO. II



1



2

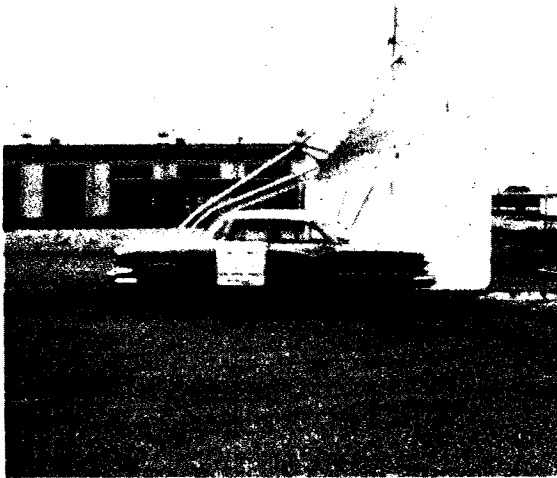

3

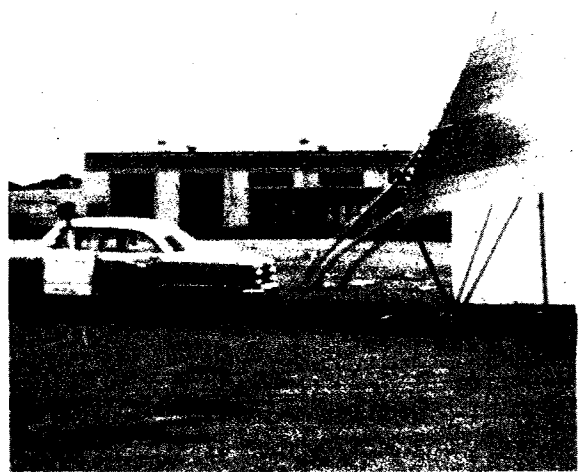

4

FIGURE 25 - SEQUENCE PHOTOGRAPHS TEST NO. II

TEST 13

Sign: 8' x 18' plywood background; two supports
Support: Unbraced post; 8WF31 steel beam with slip joint at base and "plastic hinge" joint
Impact: Left leg - 15 degree angle of incidence
Speed: Approximately 50 mph

Tests 9 and 10 showed that the unbraced post type support with slip base and hinge joint (see Figure 21 for details) functioned satisfactorily when struck at high and low speeds. However, both test were conducted by striking the post at an angle of incidence of 0 degrees. This test was conducted to determine the behavior of the post when struck at an angle. To establish the maximum angle of incidence for normal situations, reference was made to previous studies, particularly at General Motors Proving Grounds, where it was determined that under normal conditions some 95 per cent of the vehicles left the roadway at angles less than 15 degrees. On this basis the angle of incidence for this crash test was established at 15 degrees.

There was little difference in the results of this test as compared to Tests 9 and 10. Sequence photographs from the high-speed film are shown in Figure 26. From the film it was observed that the vehicle traveled approximately 8 inches deforming the front bumper and associated parts between initial contact with the post and the time slippage occurred at the base. Immediately, the post twisted approximately 15 degrees to align itself with the vehicle and this twisting caused the fracture plate on the front flange to fail. Then, the lower section of the leg rotated about the hinge joint. The post was dragged across the grill section and released free of the vehicle at a point approximately 7 feet beyond where the vehicle had first encountered the post. The lower section of the post continued to rotate about the hinge until it struck the upper portion of the post. After the vehicle had passed on beyond the sign the entire sign rotated about the right support through an angle of approximately 75 degrees.

Damage to the vehicle was limited to the bumper, grill, hood, and associated parts, (Figure 26A).

The vehicle traveled more than 350 feet after impact and crossed a drainage ditch.

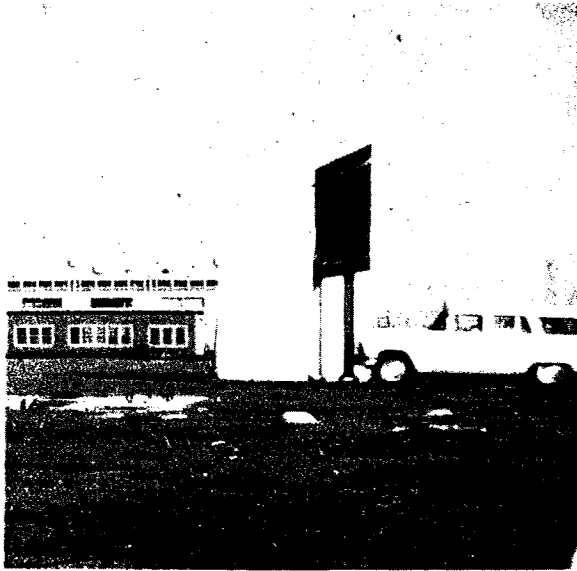

1

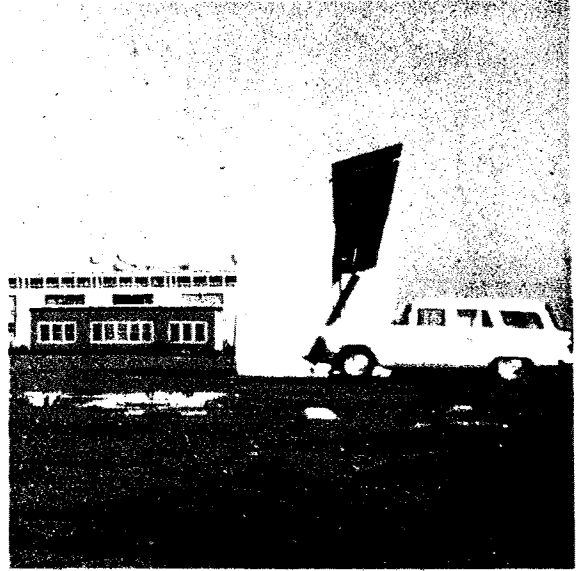

2

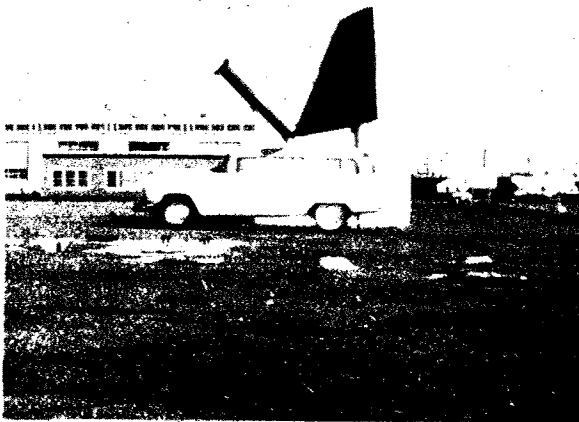

3

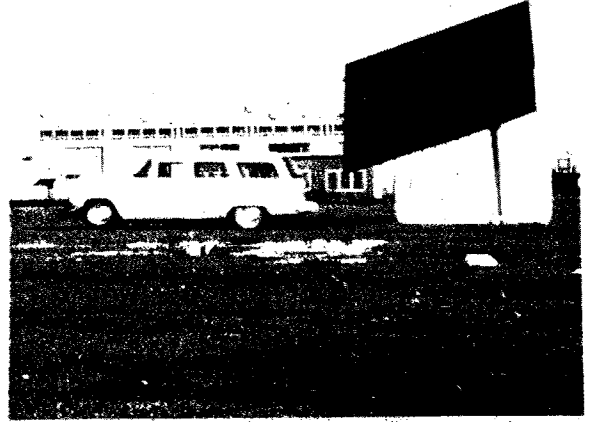

4

FIGURE 26 - SEQUENCE PHOTOGRAPHS TEST NO.13

SUMMARY

Progress has been made in reducing the effect of impact on damage to a vehicle involved in a collision with a sign support. This progress is evident by a perusal of the detailed discussion of the behavior of individual sign supports studied in the foregoing series of tests. Thorough observation of the high-speed film has clearly indicated the phenomenological behavior of the several structural supports tested. These observations have also created an insight into the formulation of a mathematical model for expressing this behavior quantitatively. Both the braced-leg support and the unbraced post with slip plane base and hinge joint have ameliorated the hazard constituted by an ordinary structural support.

CONTINUING PHASES OF RESEARCH

The procedure outlined in this progress report is a continuing phase of the research effort being conducted by the Texas Transportation Institute in cooperation with the Texas Highway Department and the U. S. Bureau of Public Roads. Techniques are being considered to improve the hinge joint both from the viewpoint of optimum behavior and to produce a system which can be readily installed and maintained in use. Other phases of the research planned or in progress are as follows:

1. Developmental design and testing of small, two-leg type signs which are subject to impact simultaneously on both legs.
2. Conceptual design of sign supports based on theoretical analysis and material characteristics.
3. Determination of wind loads on sign backgrounds by testing scale models in a wind tunnel, and by instrumentation of full-size signs subjected to natural wind forces.
4. Energy-absorbing barrier systems for bridged overhead structures and other fixed objects located near the roadway.