

GUIDE TO THE SELECTION
OF NONDIRECTIONAL INTERCHANGES

By

Charles Pinnell
James D. Barnett
John Haynes
Milton Radke

Cooperative Research with the Texas Highway Department
and the
Department of Commerce, Bureau of Public Roads

Final Report on Research Project 2-8-58-6
Ramps and Interchanges

November, 1963

TEXAS TRANSPORTATION INSTITUTE
Texas A&M University
College Station, Texas

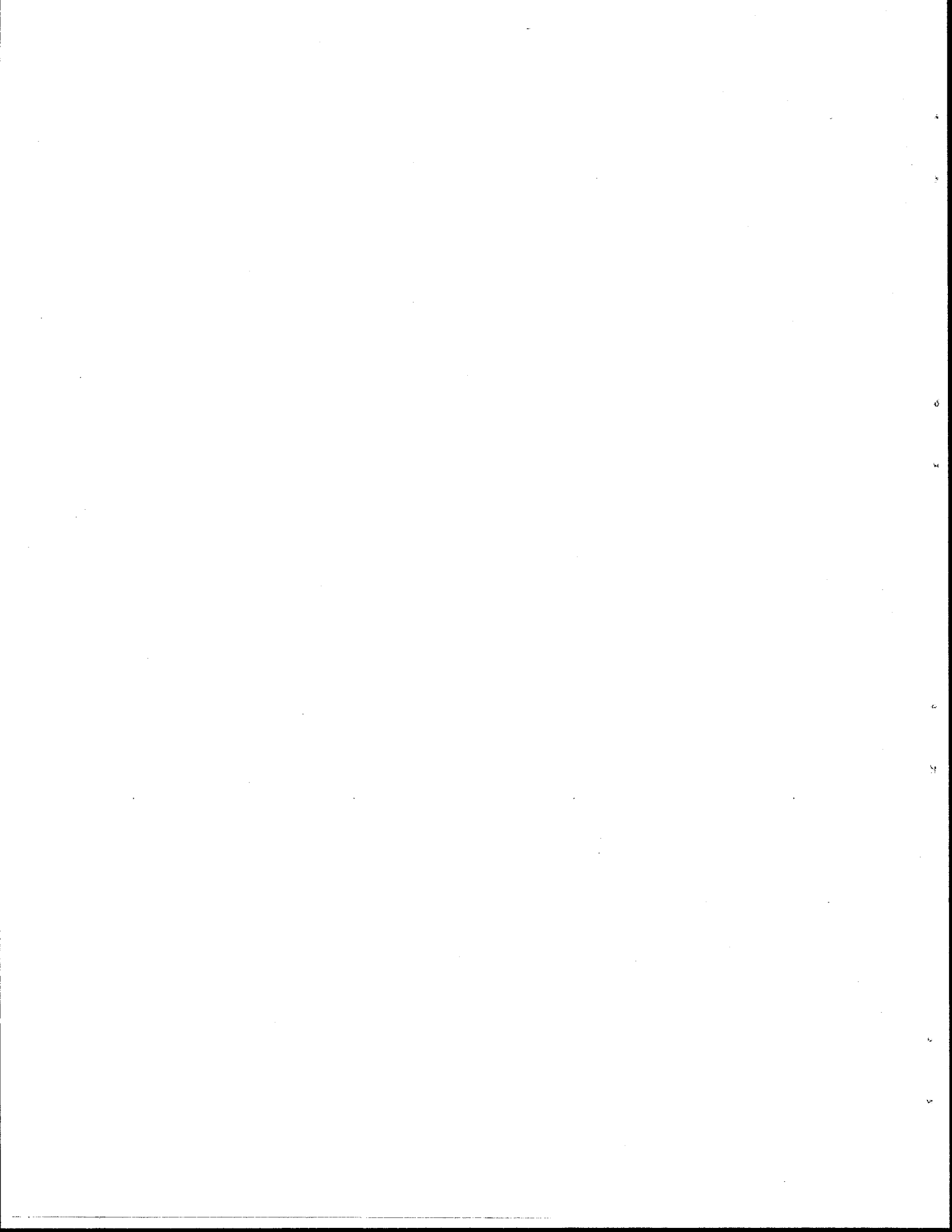

GUIDE TO THE SELECTION OF NONDIRECTIONAL INTERCHANGES

INTRODUCTION

The research project "Ramps and Interchanges" was initiated September 1, 1958 with the objective of developing design criteria for entrance and exit ramps and interchanges and to correlate design factors and operational characteristics of freeway interchanges. The research work has been concentrated in three basic areas which are as follows:

1. Freeway Entrance and Exit Ramps.
2. Diamond Interchanges.
3. Cloverleaf Interchanges.

Research publications which have been developed from the Ramps and Interchanges project are as follows:

1. "Freeway Ramps," Report 1960. Charles Pinnell and C. J. Keese.
2. "Driver Requirements in Freeway Entrance Ramp Design," Proceedings, Institute of Traffic Engineers, 1960, Charles Pinnell.
3. "Traffic Behavior and Freeway Ramp Design," Proceedings, ASCE, No. HW3, September, 1960. Charles Pinnell and C. J. Keese.
4. "Capacity Study of Signalized Diamond Interchanges," Highway Research Board Bulletin 291, 1961. Donald G. Capelle and Charles Pinnell.
5. "Design and Operation of Diamond Interchanges," Research Report, 1961. Charles Pinnell and Donald G. Capelle.
6. "Operational Study of Signalized Diamond Interchanges," Highway Research Board, 1962. Charles Pinnell and Donald G. Capelle.
7. "A Study of the Peaking Characteristics of Signalized Urban Intersections as Related to Capacity and Design," Highway Research Board, 1962. Donald R. Drew and Charles Pinnell.
8. "Design and Signalization of High-Type Intersections," Research Report, 1961. Donald R. Drew and Charles Pinnell.

9. "The Value of Signal Phase Overlap in Signalized Intersection Capacity," Traffic Engineering, December, 1962. Charles Pinnell.
10. "At-Grade Intersection Spacing on Conventional Two-Level Diamond Interchanges," Research Report, 1963, James D. Barnett and Charles Pinnell.
11. "A Comparative Study of the Conventional Diamond and Cloverleaf Interchanges with Respect to Ramp Capacity and Vehicular Delay," Research Report, 1963. James D. Barnett.

The purpose of this final report is to present data from a comparative study of diamond and cloverleaf interchanges with a summary of previous research findings as to provide a guide to the selection of nondirectional interchanges.

BASIC COMPARISONS

Interchange Types

After considering the various types of nondirectional interchanges, the following three interchange types were selected for comparative study:

1. Conventional Two-Level Diamond.
2. Cloverleaf Without Collector - Distributor Roads.
3. Cloverleaf with Collector-Distributor Roads.

It is recognized that there are numerous variations of the above interchanges such as the split-diamond, three-level diamond, and partial cloverleaf but it was felt that basic studies of the above interchanges would provide data applicable to the different variations.

Comparative Factors

Studies were initiated to compare the diamond and cloverleaf interchanges with regard to the basic factors of (1) capacity, (2) efficiency, and (3) cost.

Specific data on these factors considering both the diamond and cloverleaf interchanges will be presented in the following material.

RESEARCH STUDIES

Research studies on the "Ramps and Interchanges" project were conducted in a number of locations. Some of the principal study locations were as follows:

1. Wayside Drive Interchange - Gulf Freeway Houston. Diamond interchange capacity studies. Figure 1.
2. Cullen Blvd. Interchange - Gulf Freeway Houston. Diamond interchange capacity studies. Figure 2.
3. Marshall Street On-Ramp - San Antonio. Ramp capacity and delay studies. Figure 3.
4. Berry Street Interchange - Fort Worth. Capacity, signalization and delay studies on diamond interchange. Figure 4.
5. North Central Expressway - Loop 12 Interchange Dallas. Cloverleaf capacity and delay studies. Figure 5.
6. Griggs Road Entrance Ramp - Gulf Freeway Houston. Capacity and delay studies. Figure 6.

Project studies were conducted at the above locations during the period September 1958 to September 1963 to develop data on the factors indicated. Data reported in this report were collected at locations listed as numbers 3, 4 and 5.

INTERCHANGE CAPACITY

Diamond Interchange

A procedure for determining the capacity of a diamond interchange was developed in an early phase of the research work. This procedure is explained and illustrated in references 4 and 5 on page 1.

The capacity of a conventional diamond interchange (Figure 7) is determined in terms of the number of vehicles able to move through the signalized at-grade intersections. The "critical capacity" of a diamond interchange, defined as the sum of the largest single lane volume on each of the four approaches as shown in Figure 8, can be as large as 1760 vehicles per hour when proper signalization is utilized.

If a total of three lanes is assumed on each of the four approaches to the diamond the following total capacity is available:

$$\text{Total Capacity} = 3 \times 1760 = 5280 \text{ vph}$$

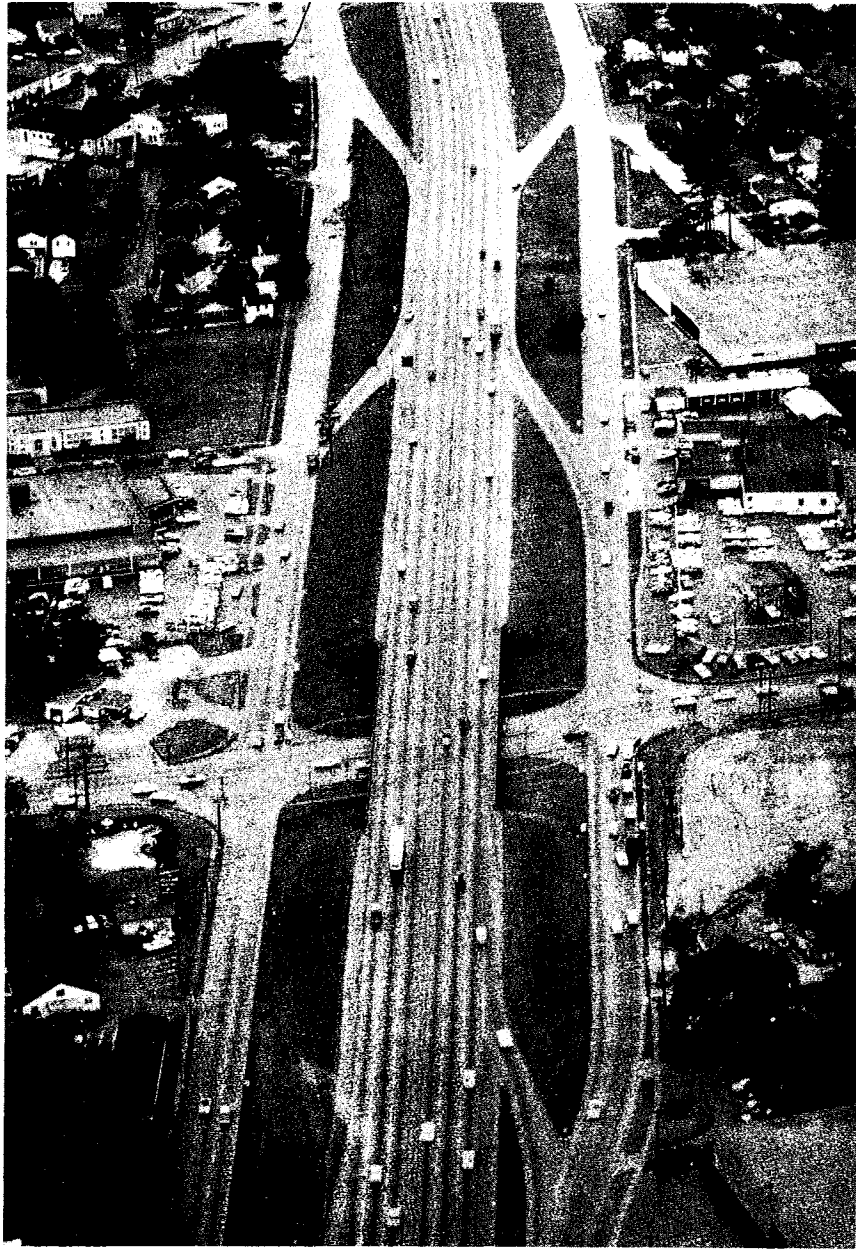

**WAYSIDE DRIVE INTERCHANGE
HOUSTON, TEXAS**

FIGURE 1

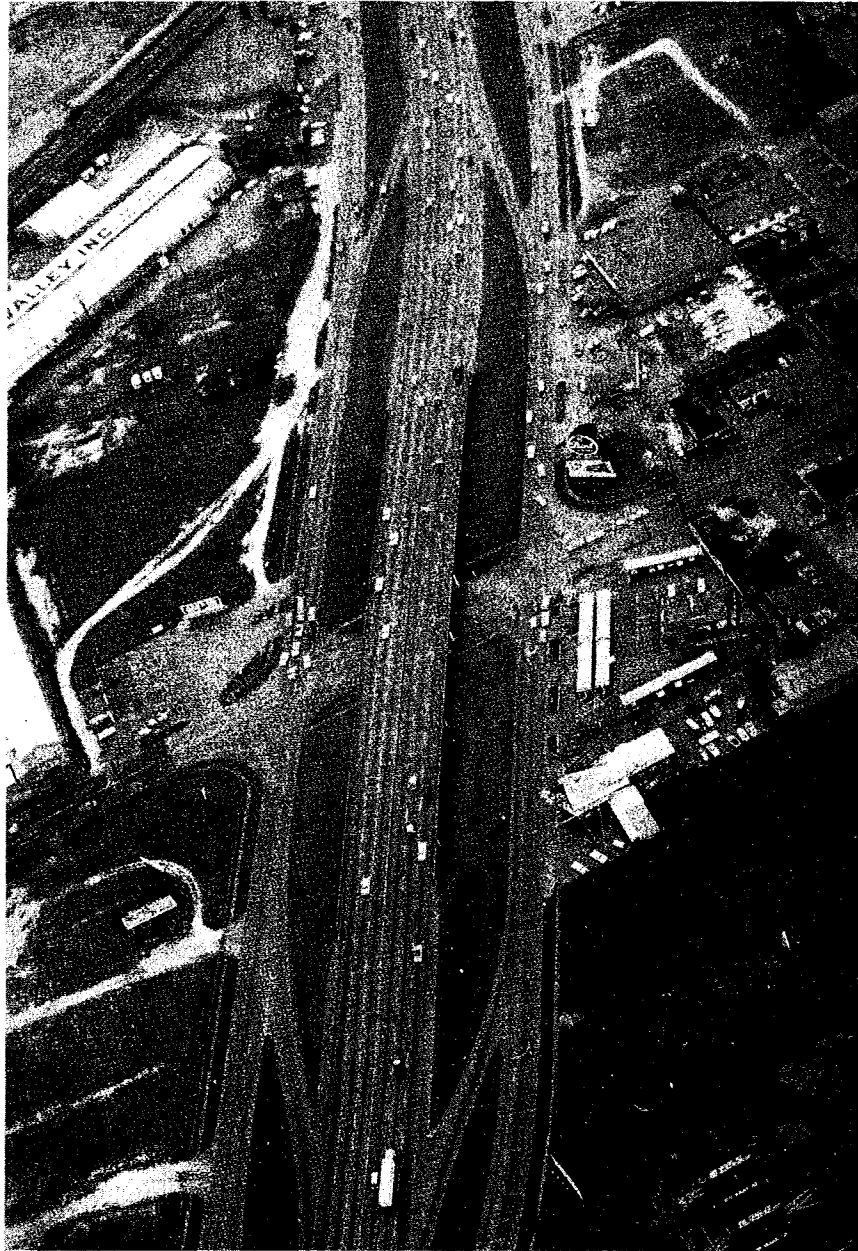

**CULLEN BLVD. INTERCHANGE
HOUSTON, TEXAS**

FIGURE 2

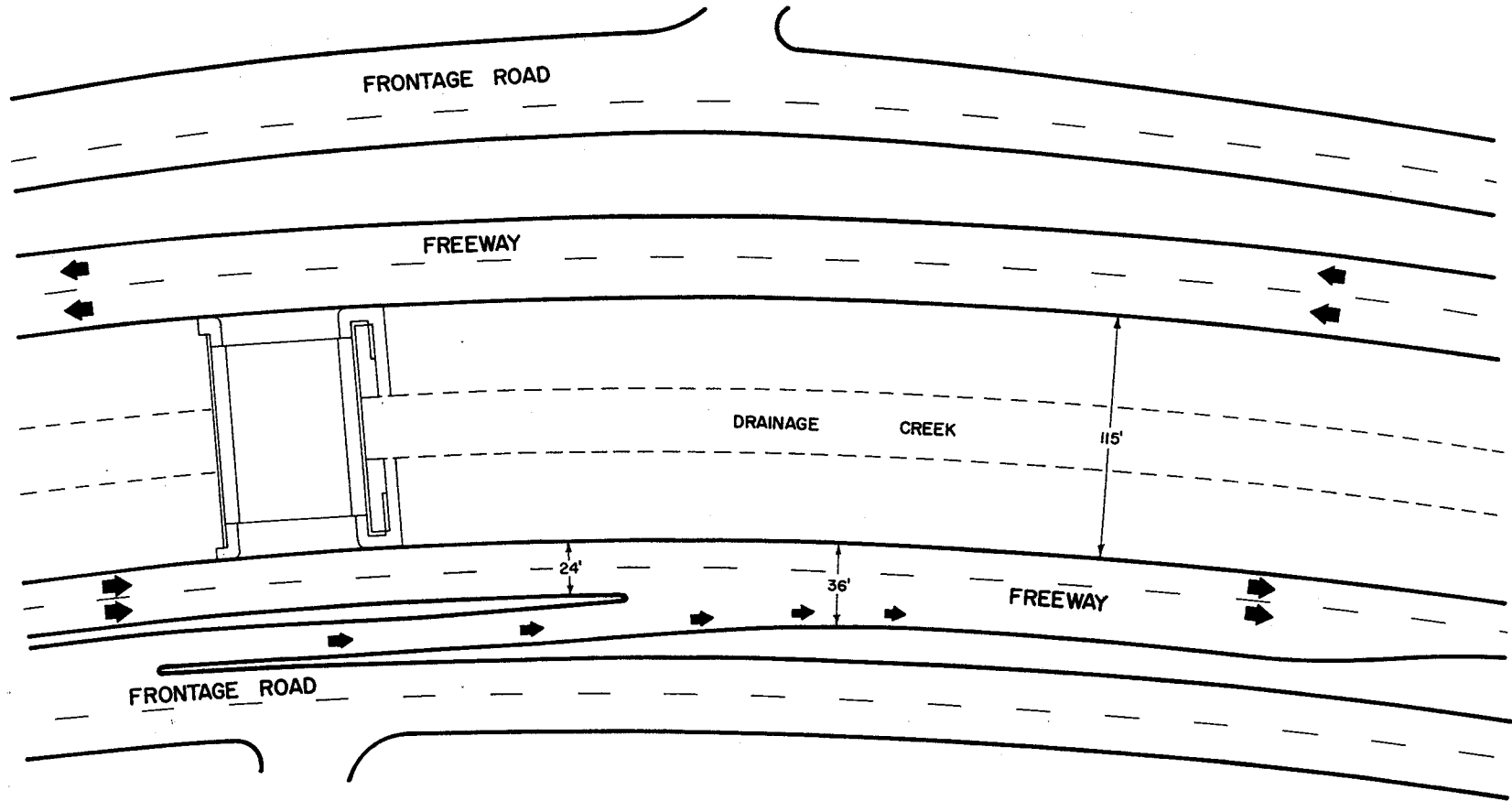

MARSHALL STREET ENTRANCE RAMP

FIGURE 3

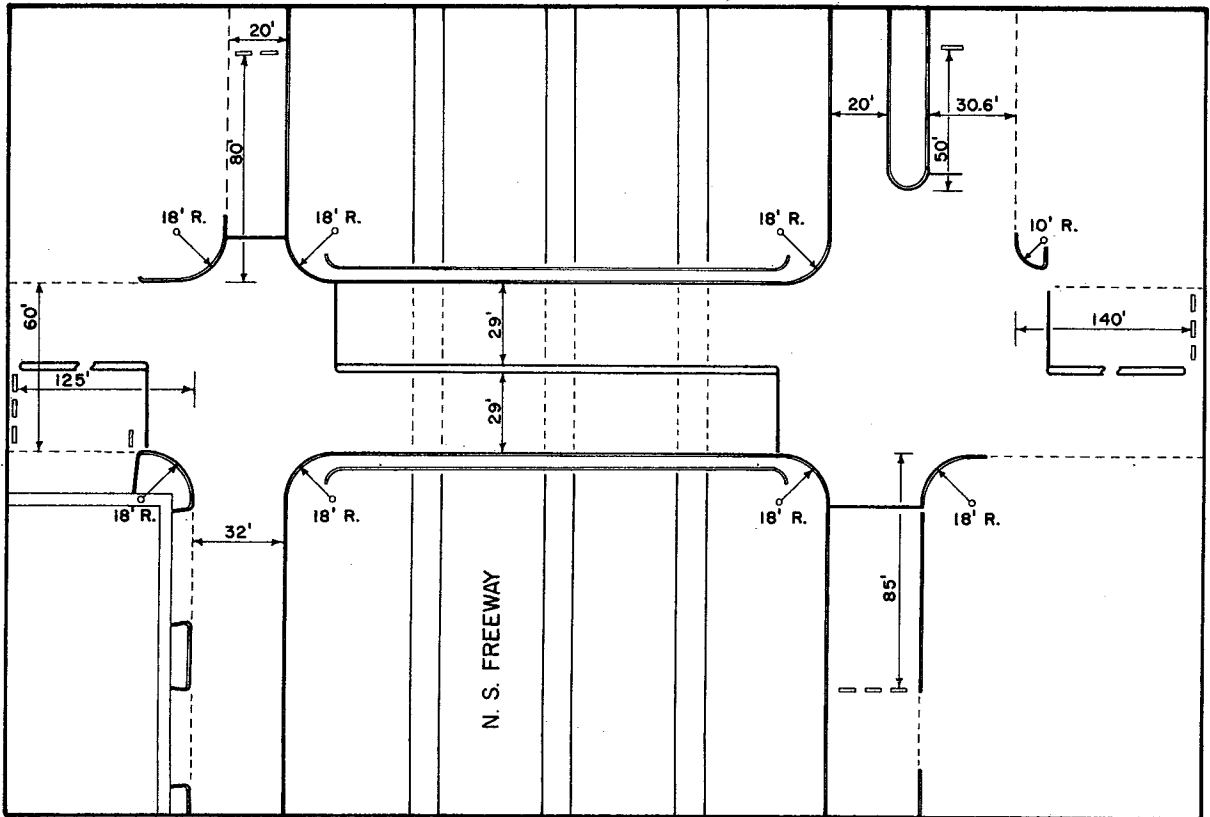
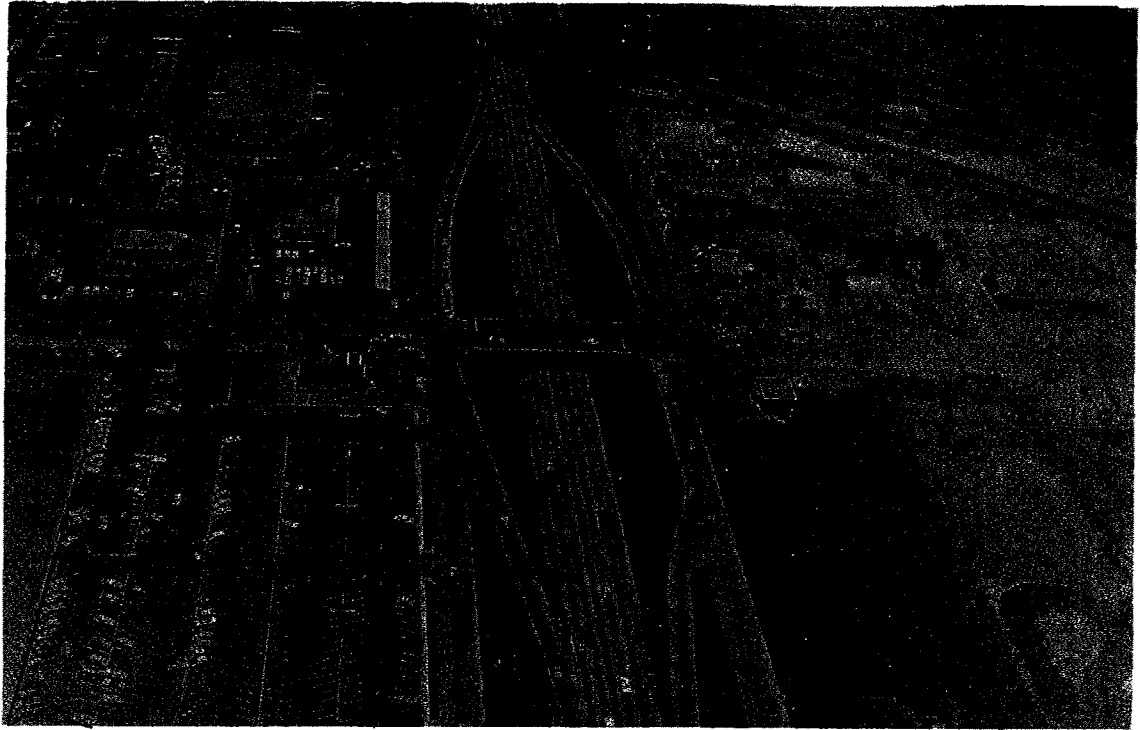

BERRY STREET INTERCHANGE
FORT WORTH, TEXAS

FIGURE 4

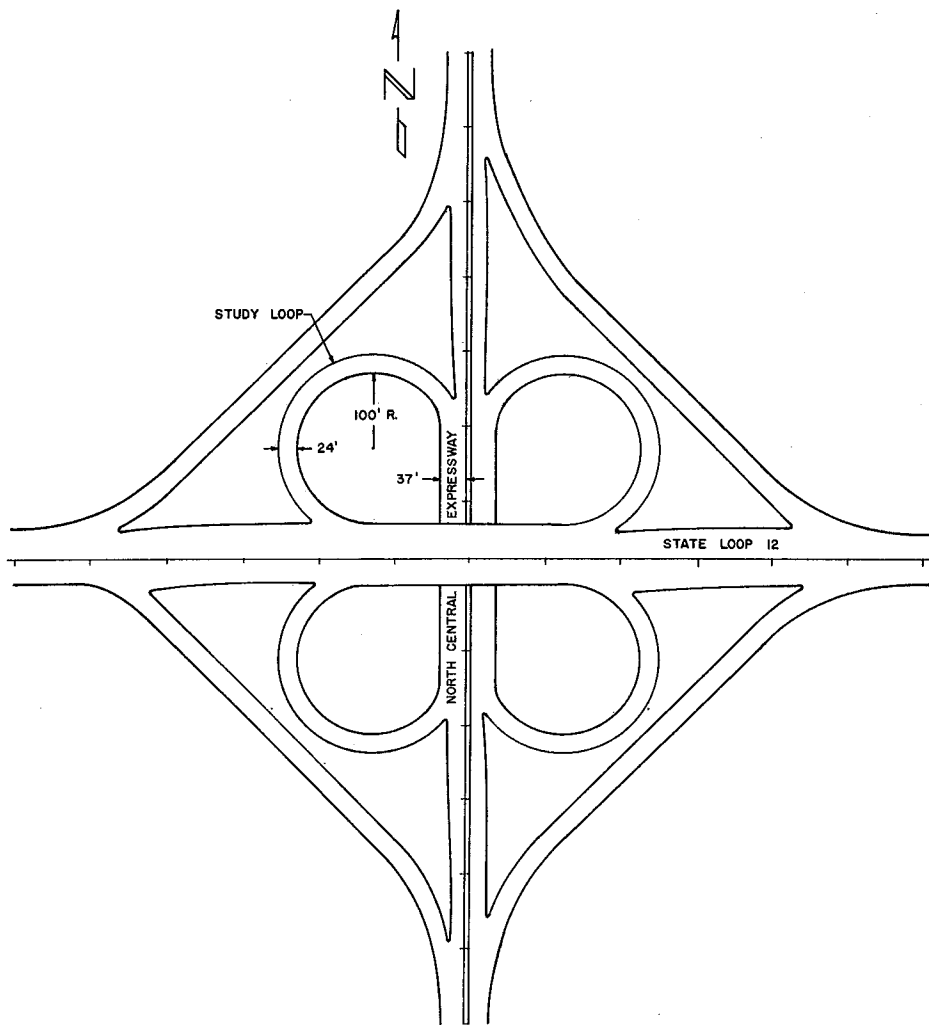
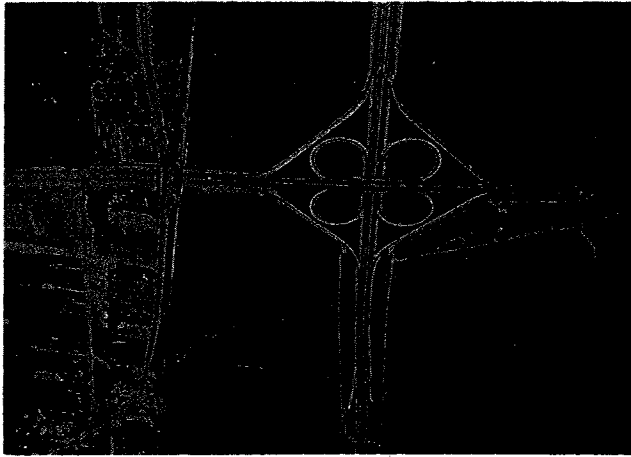

LOOP 12-NORTH CENTRAL EXPRESSWAY INTERCHANGE
DALLAS, TEXAS

FIGURE 5

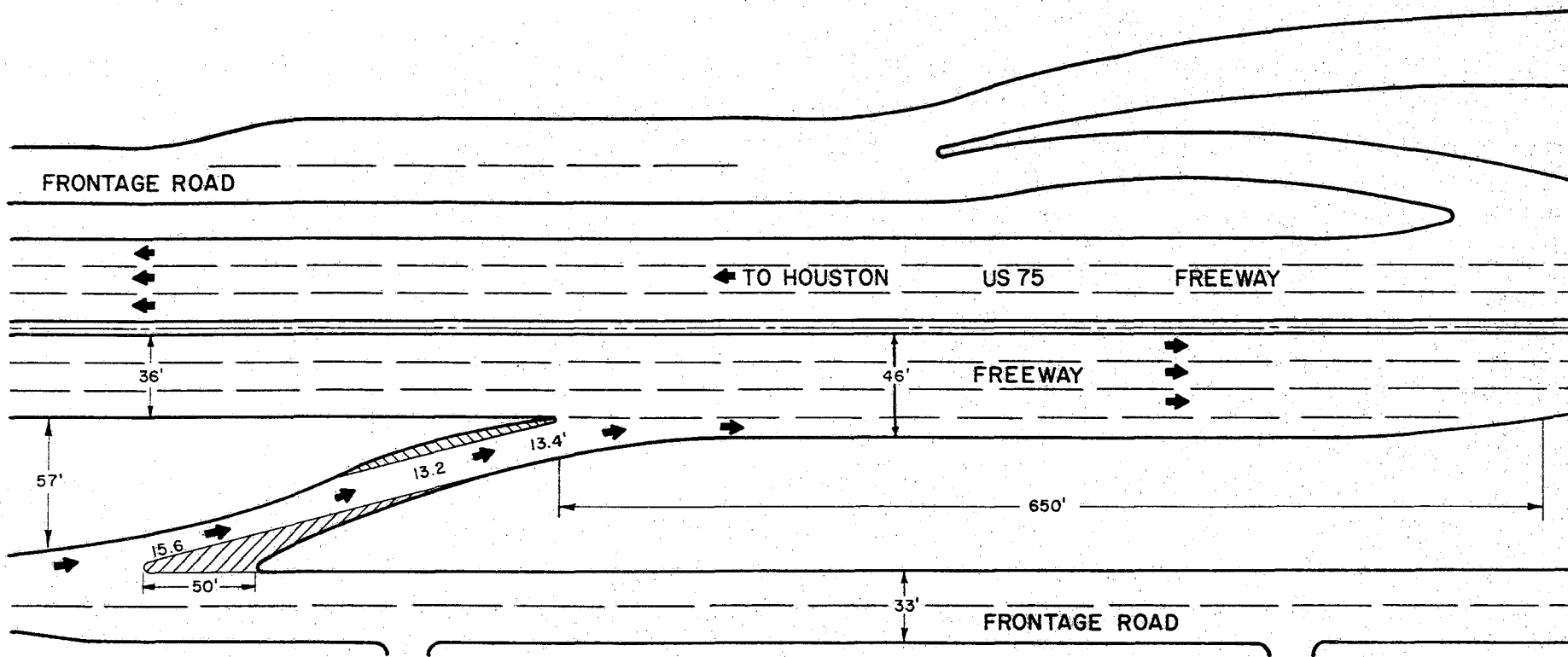

GRIGGS ROAD ENTRANCE RAMP
GULF FREEWAY HOUSTON

FIGURE 6

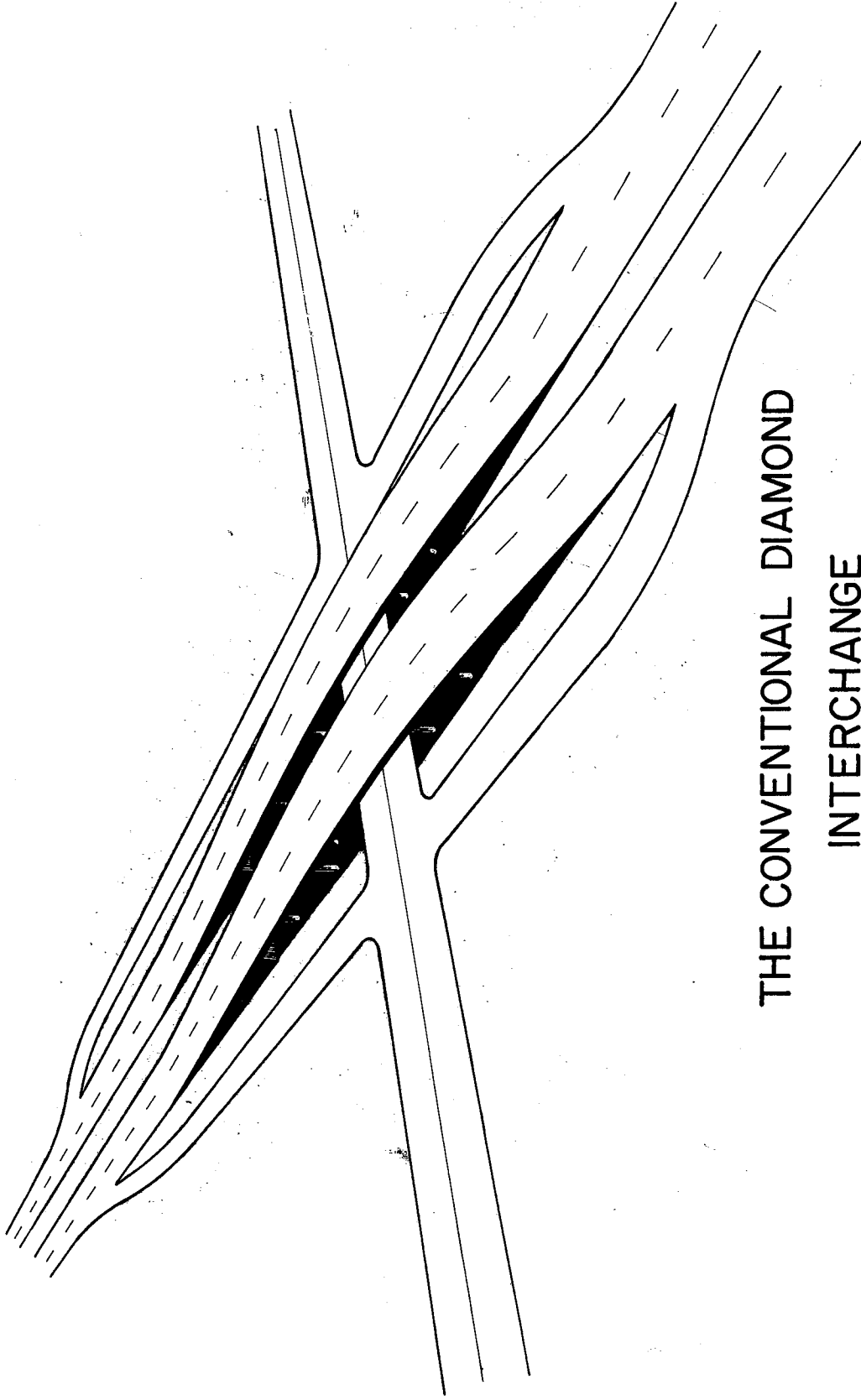

THE CONVENTIONAL DIAMOND
INTERCHANGE

FIGURE 7

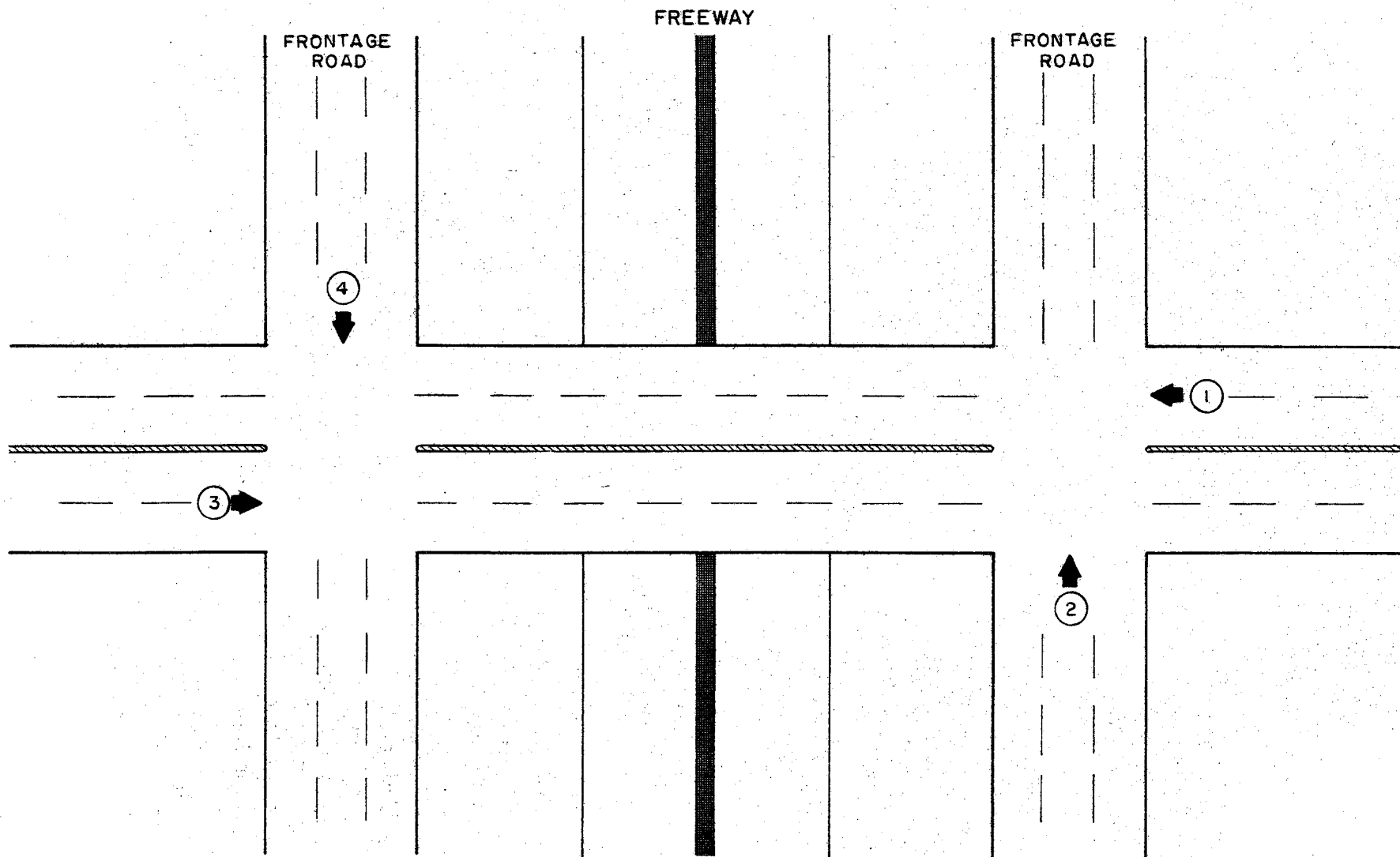

CRITICAL FLOW APPROACHES ON
SIGNALIZED DIAMOND INTERCHANGE

FIGURE 8

It is not possible to set a capacity value which will fit all diamond interchanges as the capacity will vary depending upon the number of lanes available on each approach. Thus, it is necessary to utilize the capacity evaluation procedures to study the capacity of any given diamond interchange.

Attention should be called to the fact that the "critical capacity" is related only to that traffic passing through the signalized intersections. Special right turn lanes such as those shown in Figure 9 can divert traffic around the signalization and greatly increase the capacity of the diamond interchange.

Cloverleaf Interchange

In the case of the cloverleaf interchange it is not possible to define its capacity in terms of total interchange volume as in the case of the diamond interchange since the movements are not restricted by traffic signals. Traffic studies indicate, however that the basic capacity limitation of the cloverleaf interchange without collector-distributor roads is on the left turn movement either off of or on to the freeway. This movement passes around a loop and enters the freeway or major street through an entrance ramp. This movement is restricted to one lane and the ramp geometrics are less than desirable due to the short loop radius.

The left turn movement on a cloverleaf without collector-distributor roads was studied in detail at the study site shown in Figure 5. From analyses of the traffic data the loop capacity curve shown in Figure 10 was developed.

The loop capacity is directly related to the volume in the outside lane of the freeway and drops to less than 600 veh per hour with freeway volumes in the outside lane greater than 1200 veh per hour.

For a cloverleaf with a collector-distributor road as shown in Figure 11, the loop capacity for major arterial to freeway interchange is not dependent upon freeway volume. The loop traffic enters the collector-distributor road from the loop and interchanges with the freeway through a regular frontage road entrance ramp. However, for traffic interchange from the freeway to the major arterial, the capacity curve shown in Figure 10 is applicable.

Due to the improved geometrics that can be obtained in the design of the frontage road to the freeway ramp, increased capacity can be obtained. Studies of this type ramp were conducted at the study

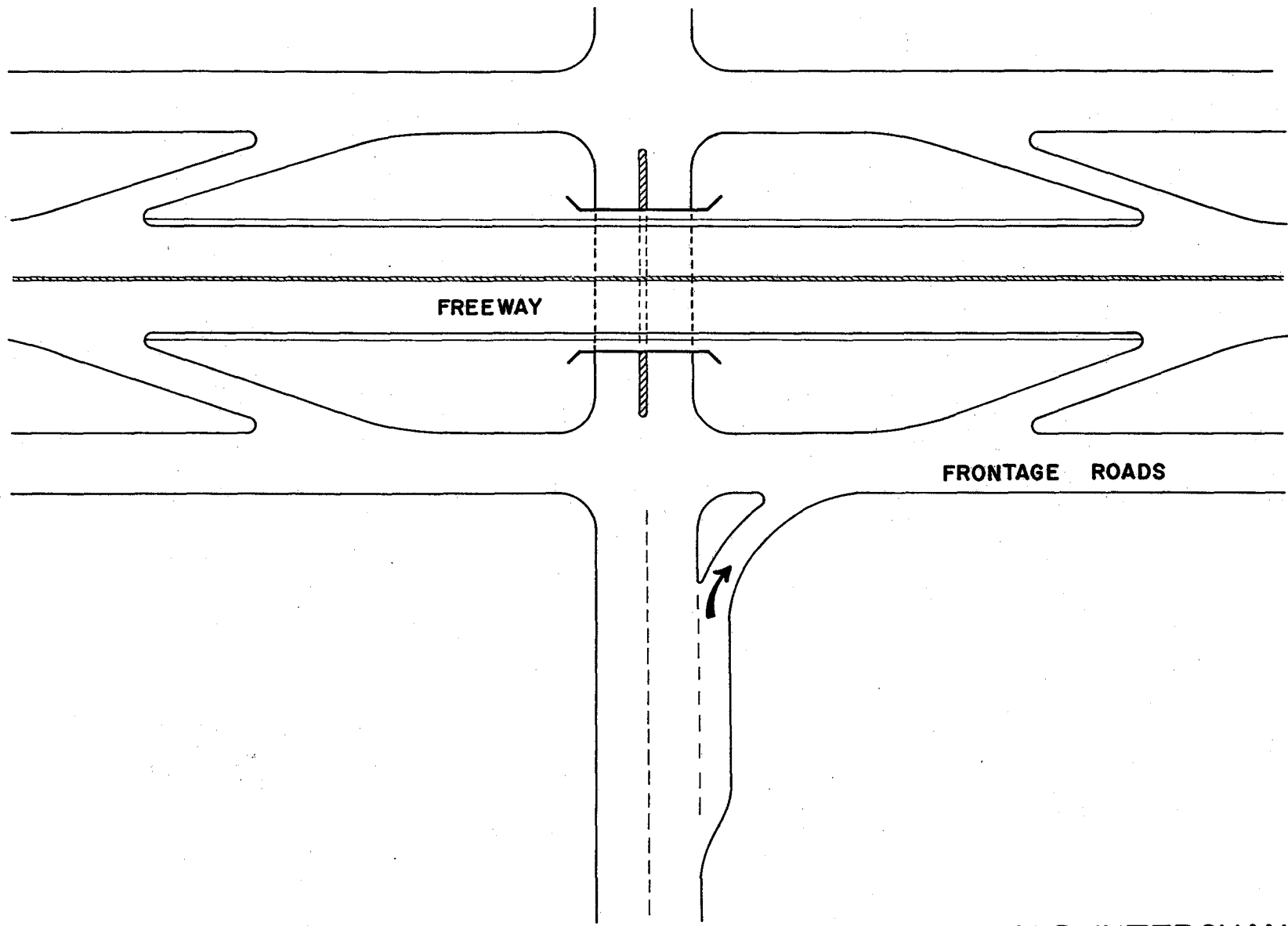

SPECIAL RIGHT TURN LANE FOR CONVENTIONAL DIAMOND INTERCHANGE

FIGURE 9

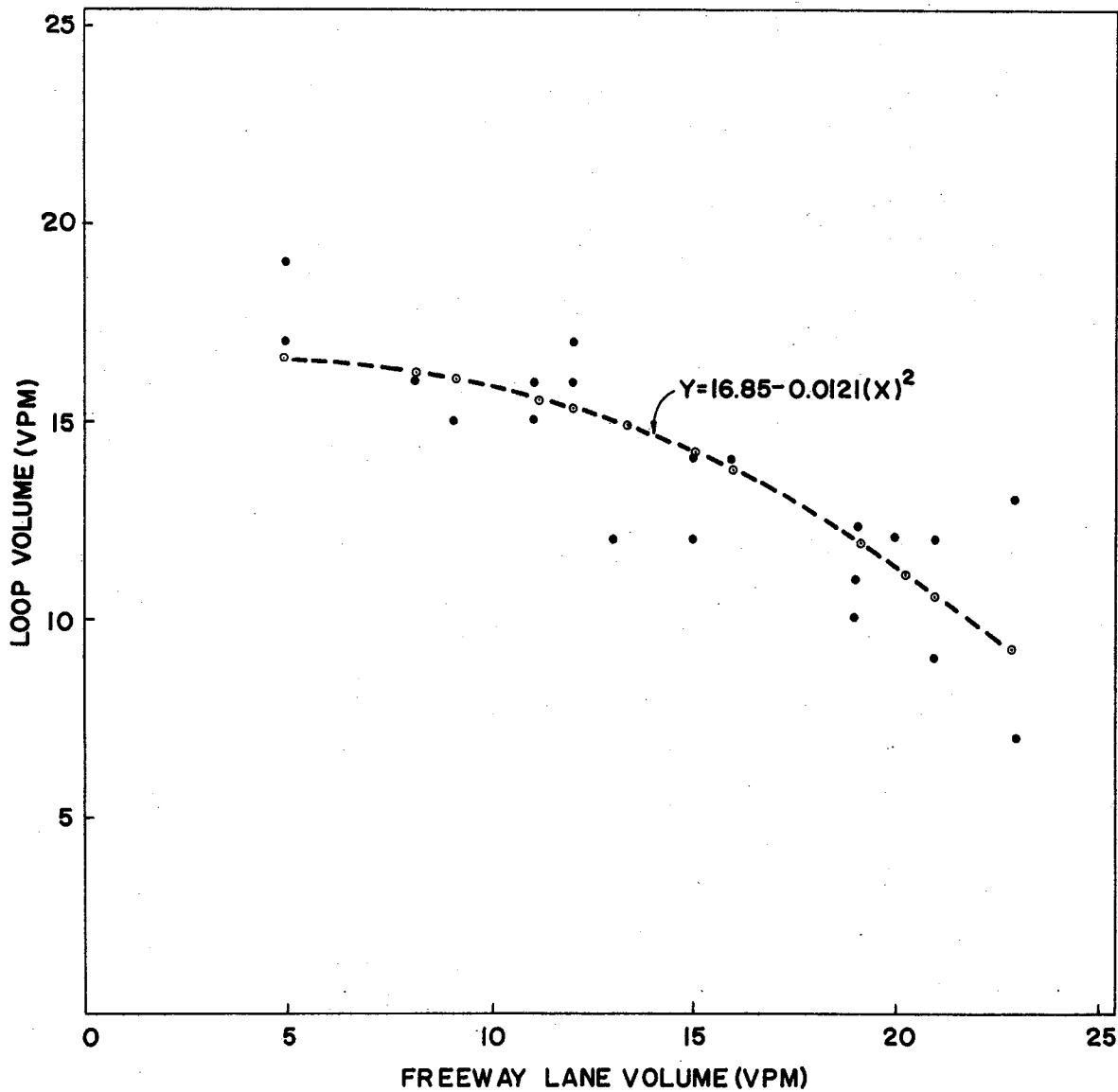

PLOT OF OUTSIDE FREEWAY LANE
 VOLUME VERSUS CLOVERLEAF LOOP
 VOLUME AT OR NEAR CAPACITY

FIGURE 10

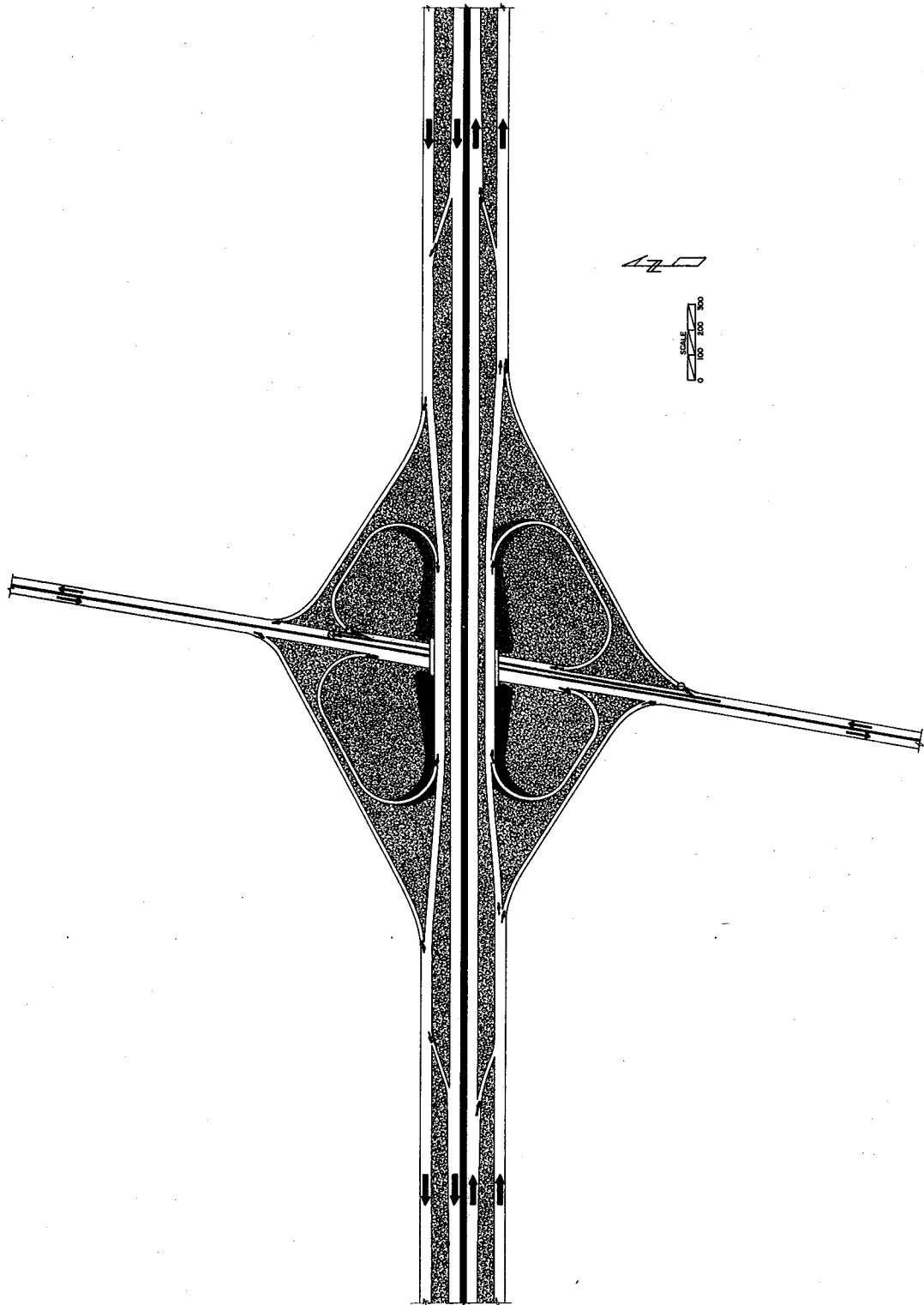

TYPICAL CLOVERLEAF INTERCHANGE
WITH COLLECTOR - DISTRIBUTOR ROADS

FIGURE 11

site shown in Figure 3 and the capacity curve shown in Figure 12 was developed. This ramp capacity was approximately 300 veh per hour higher through the range of the freeway volumes than that of a direct loop ramp.

Utilizing the previously presented curves and considering specific design volumes, it is possible to make a capacity analysis of any given cloverleaf interchange.

INTERCHANGE EFFICIENCY

The basic consideration in efficiency is the delay encountered by traffic in passing through an interchange. In order to compare this delay a study of specific movements was conducted. The traffic movements were considered in the two main categories of (1) traffic moving from the major street to the freeway and (2) traffic moving from the freeway to the major street.

After considering both general movements it was decided that the traffic movement from the major street to the freeway was the most critical for comparison and was further broken down as follows:

Movement A--Traffic passing through the interchange. This is non-interchanging traffic and usually makes up only 20-30 per cent of the total traffic in the interchange area. The cloverleaf interchange causes only slight delay to this traffic due to marginal friction. Due to the signalization, the diamond interchange will stop a portion of this movement.

Movement B--Traffic turning right onto the freeway. This movement can be handled by right-turn loops or special right turn lanes on both the diamond and cloverleaf interchange and the delay is essentially the same for both types of interchanges.

Movement C--Traffic turning left onto the freeway. This movement encounters delay on both types of interchanges.

After considering all three movements it was decided that the most critical movement to compare was movement C, and specific studies were conducted to study this movement on both the cloverleaf and diamond interchange.

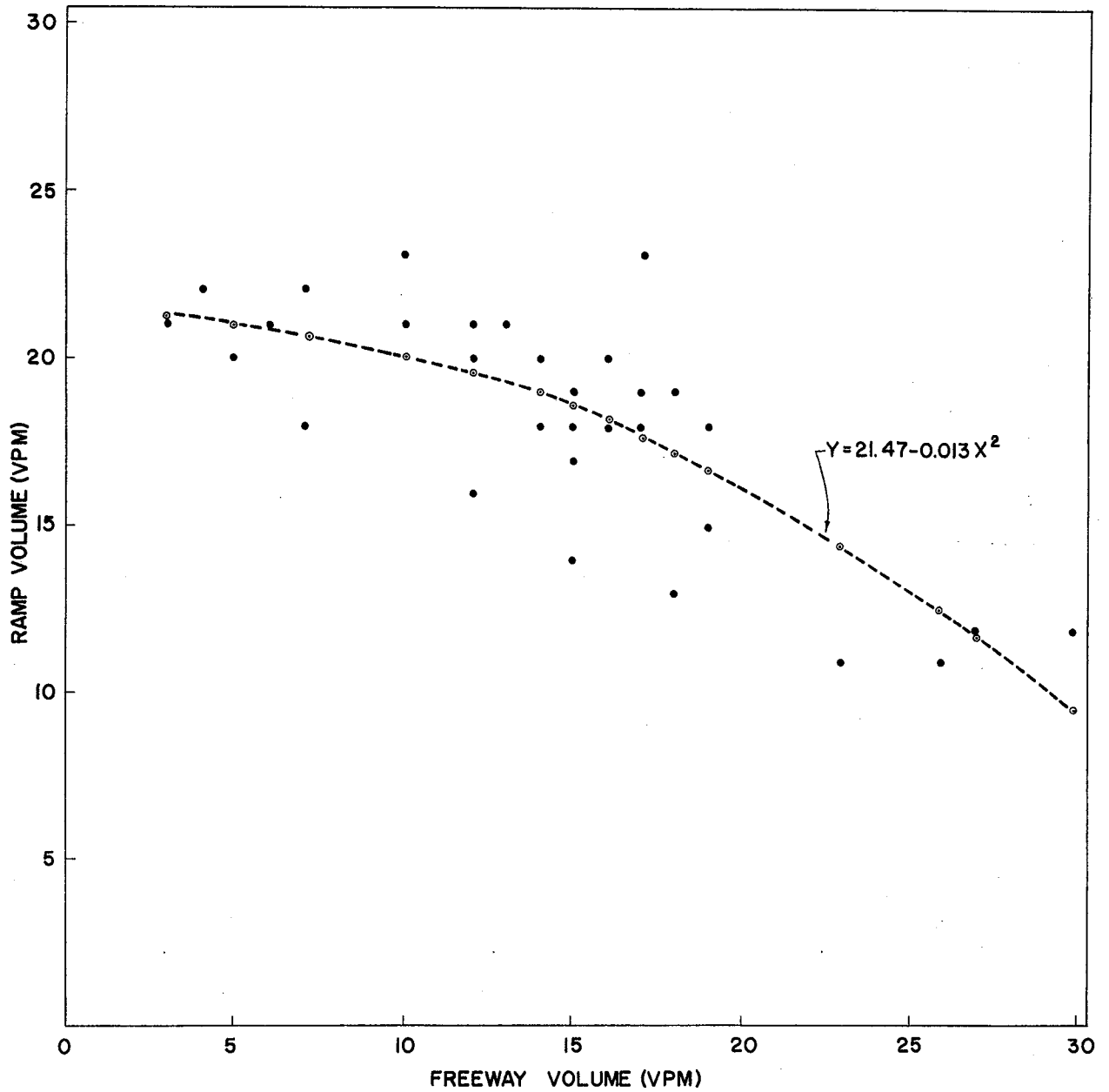

PLOT OF OUTSIDE FREEWAY LANE
 VOLUME VERSUS DIAMOND ON-RAMP
 VOLUME AT OR NEAR CAPACITY

FIGURE 12

Diamond Interchange Travel Time

Motion picture studies were conducted at the Berry Street Interchange shown in Figure 4 to obtain data on the average travel time for a vehicle to pass through the signalized intersections, turn left and move onto the freeway (Figure 13). This travel time was broken down into three basic parts as follows:

1. Time to move through the at-grade intersections.
2. Time to move from at-grade intersection to ramp entrance.
3. Time to move into the freeway from the ramp.

It was found that the time to move through the signalized intersections was largely dependent upon the cycle length of the signals. The cycle length in turn was found to be related to the total intersection volume as shown in Figure 14. Thus as the intersection volume increased, the cycle length increased and the travel varied as shown in Figure 15. Substantial delay was encountered when cycle lengths increased to 80 or more seconds in length.

The time to move from the at-grade intersection to the ramp entrance was a function of the ramp location and was computed assuming a speed of 30 mph.

The time to move from the ramp entrance into the freeway was determined from studies of entrance ramp operation. A total entry time was determined by combining the average travel time for ramp vehicles under free flow conditions to move into the freeway with an average delay time at entrance ramps. The average free flow time for ramp entrance was found to be 13.4 seconds and average delay times were developed as shown in Figure 16.

From the curves and data previously mentioned, it is possible to fix the average travel time for a left turning movement on a diamond interchange. The following are examples of this determination:

Example 1

Cycle Length	115 sec.
Freeway Flow in the Outside Lane	1200 veh/hr
Left Turn Volume	600 veh/hr

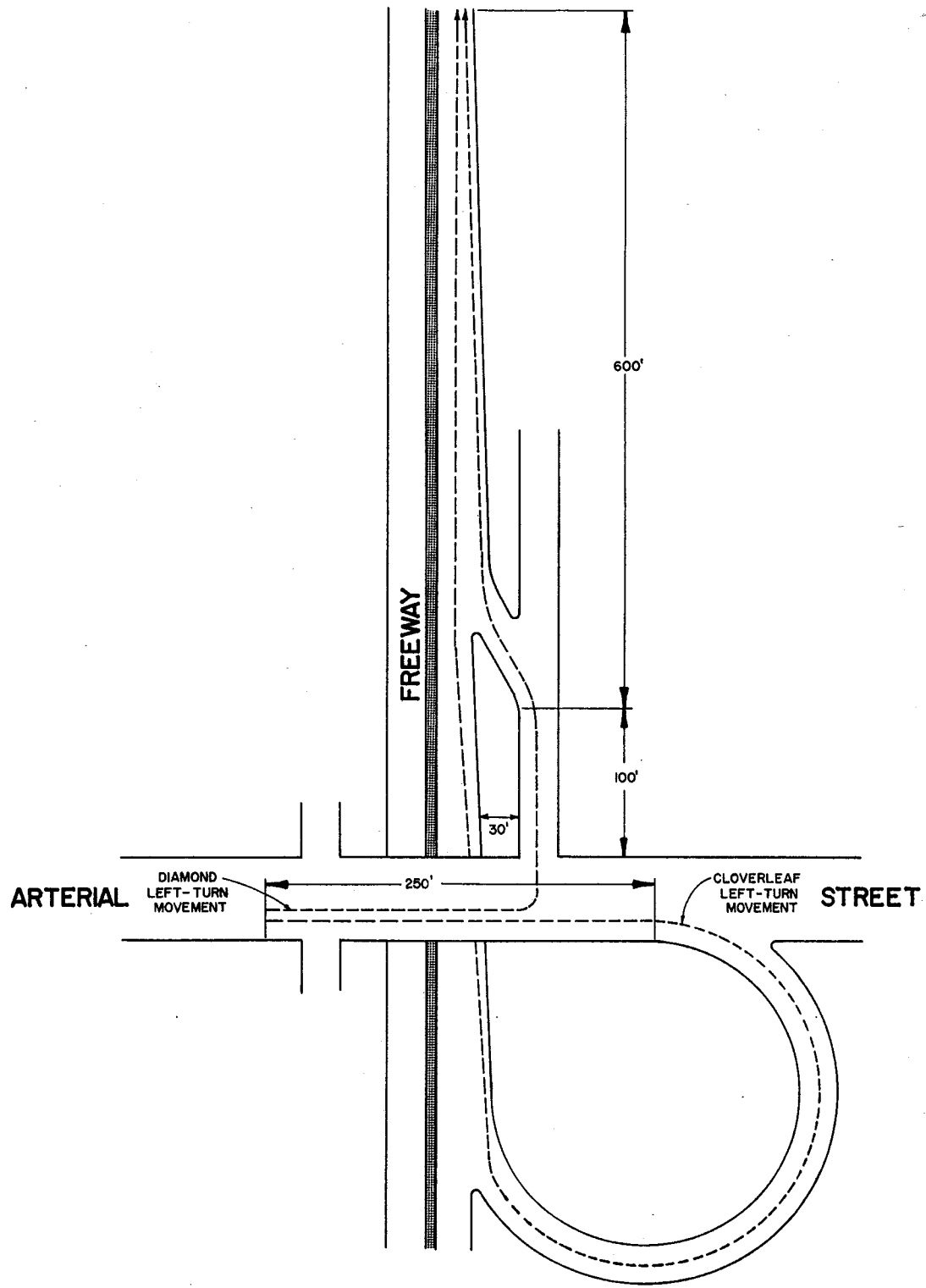

**DIAMOND AND CLOVERLEAF
LEFT-TURN MOVEMENTS**

FIGURE 13

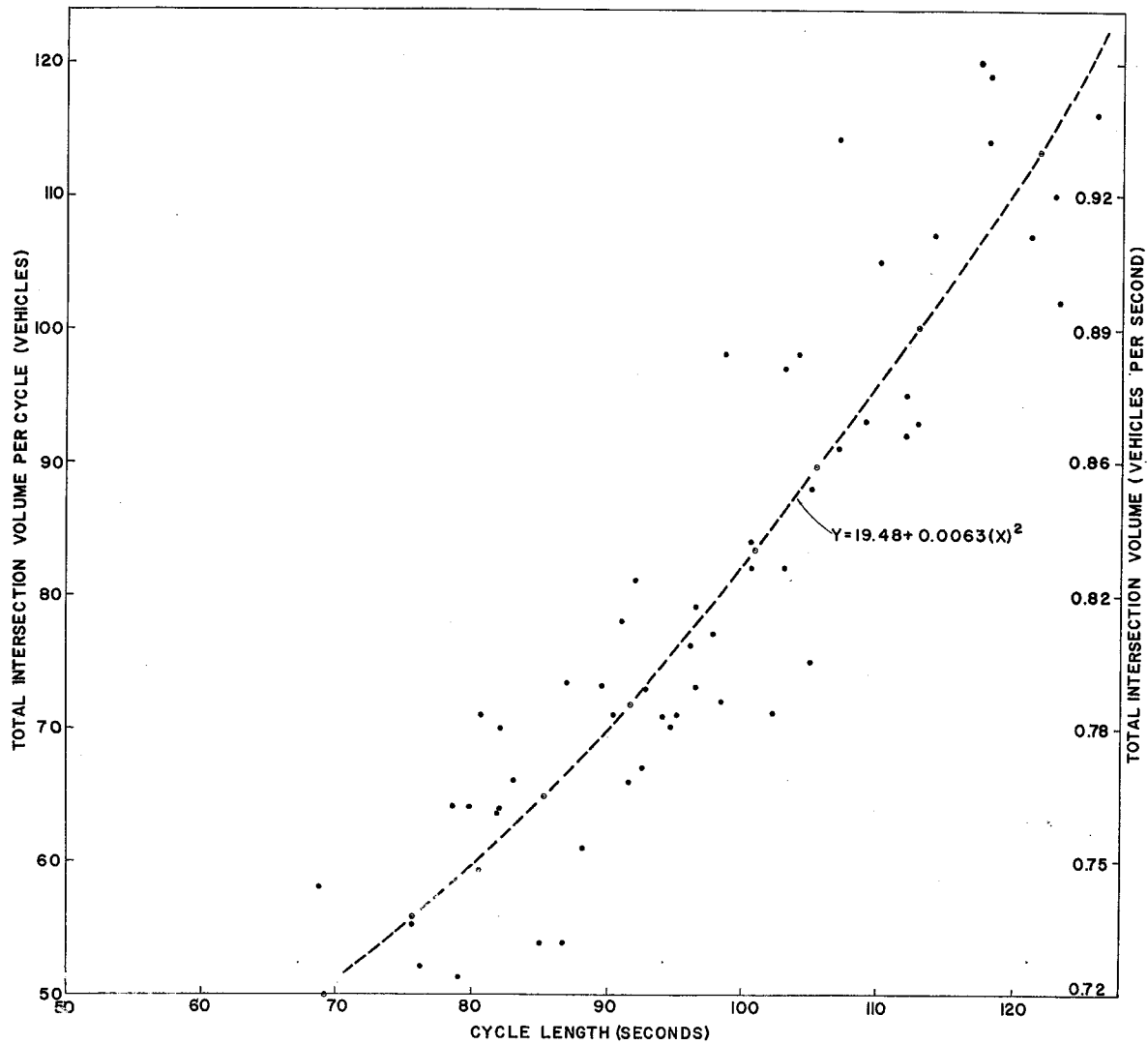

PLOT OF CYCLE LENGTH VERSUS
TOTAL INTERSECTION VOLUME PER CYCLE

FIGURE 14

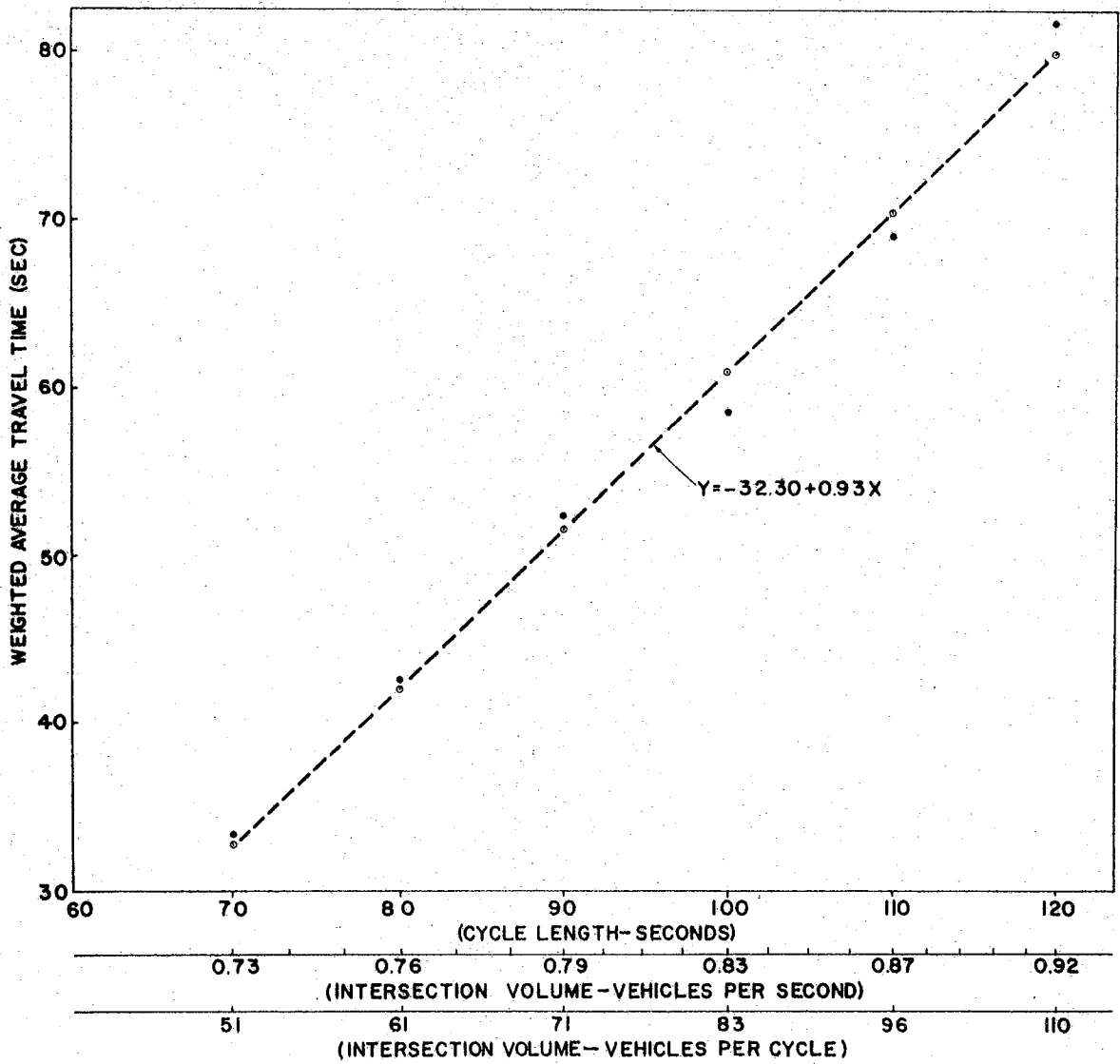

PLOT OF WEIGHTED AVERAGE TRAVEL TIME FOR INSIDE LANE OR LEFT TURN LANE QUEUES

FIGURE 15

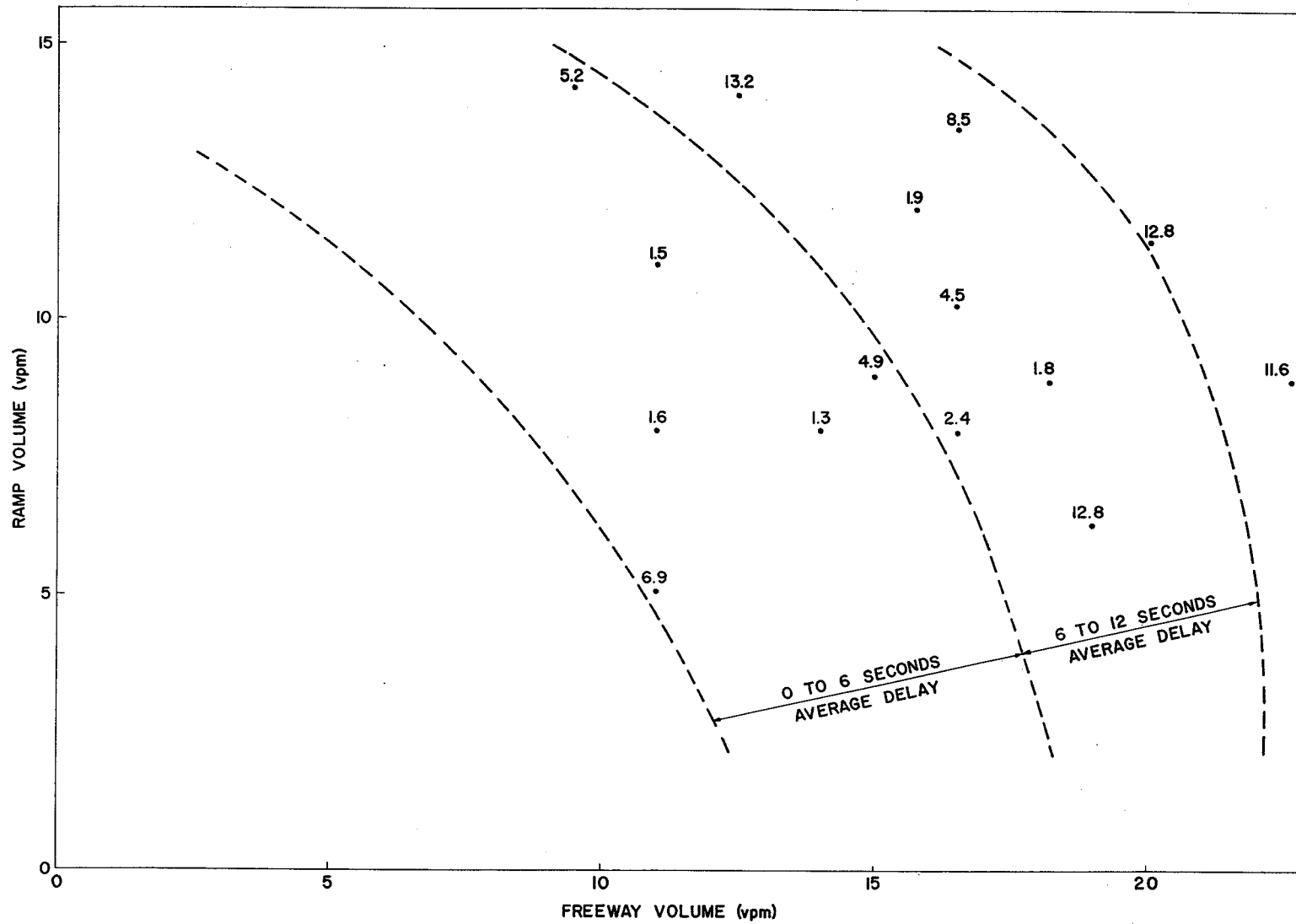

AVERAGE DELAY ON DIAMOND RAMP

FIGURE 16

Travel Times

(a)	Through signals	75.0 sec.
(b)	Time to Ramp Entrance	3.4 sec.
(c)	Time to enter Freeway	25.4 sec.
	Total	103.8 sec.

Example 2

Same traffic but utilizing a 70 sec. cycle

Travel Times

(a)	32.0 sec.
(b)	3.4 sec.
(c)	25.4 sec.
Total	60.8 sec.

The effect of the cycle length is demonstrated by the previous examples. The long cycle lengths observed in the Berry Street Study indicated that the completely efficient overlap phasing was not being obtained. With proper overlap phasing it would be possible to carry the traffic volume encountered on a 60-80 second cycle.

An earlier operational study conducted at the Berry Street Interchange (Report Number 5) offers evidence that it was possible to operate the interchange efficiently on a 60-80 second cycle. The data listed below were taken from this study and show the variation in cycle length obtained

Berry Interchange Data
Period - 4 p.m. to 5:20 p.m.

Study	System	Average Cycle Length	Interchange Total Volume
I	3-Phase	118	3856
II	4-Phase	105	3930
III	4-Phase/Overlap	77	3825
IV	Fixed Time	80	3778

from various phasing arrangements. With the proper phasing and signal equipment adjustment, however, it was possible to operate satisfactorily with an 80 second cycle or less.

A further illustration of the ability to carry large volumes with a 60-80 second cycle was reported in a recent California study.¹ This study involved conventional diamond interchanges whose signalization utilized the recommended phasing and which operated on a 60 second cycle. The volumes moved on this 60 second cycle are shown in Figure 17 and compared with the Berry Street volumes. The report indicated that peak hour traffic at these interchanges moved with no apparent congestion and with small queue lengths.

In summary it can be stated that if efficient phasing is utilized, cycle lengths of 60-70 seconds are satisfactory and that the average delay to a left turning vehicle approaching a diamond interchange will be on the order of 50-60 seconds during peak periods of traffic flow.

¹ "Signalization of Diamond Interchange" by Salem Spitz in April 1964 issue of Traffic Engineering.

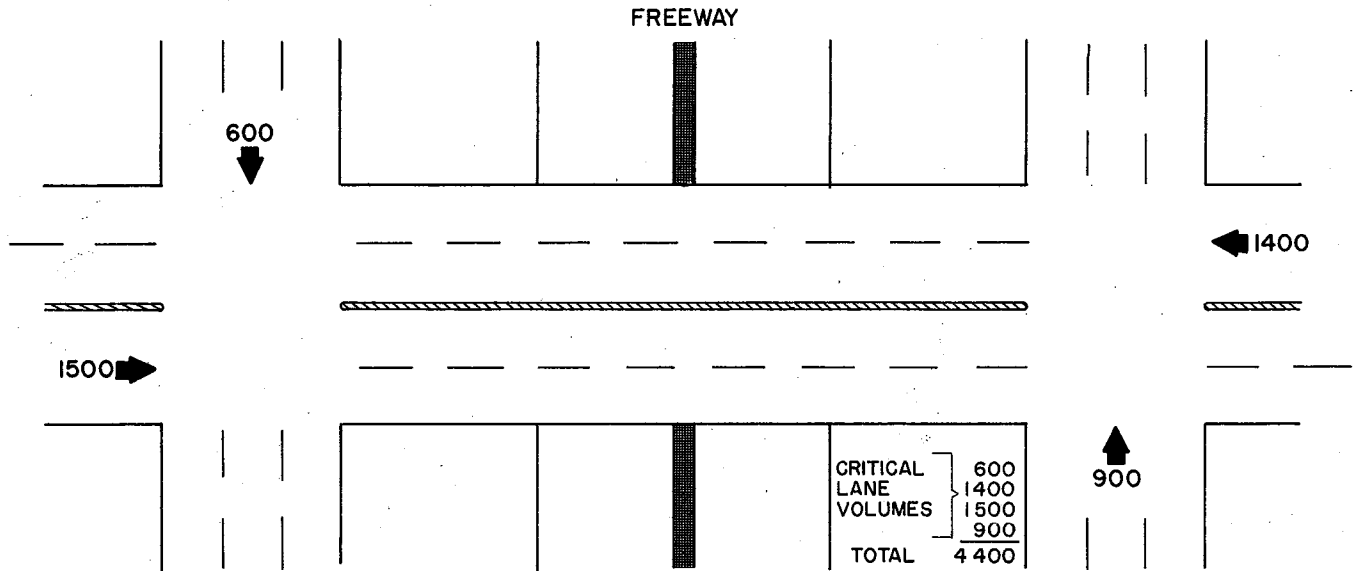

CALIFORNIA DATA

CYCLE LENGTH FOR FIXED TIME
CONTROLLER = 60 SECONDS

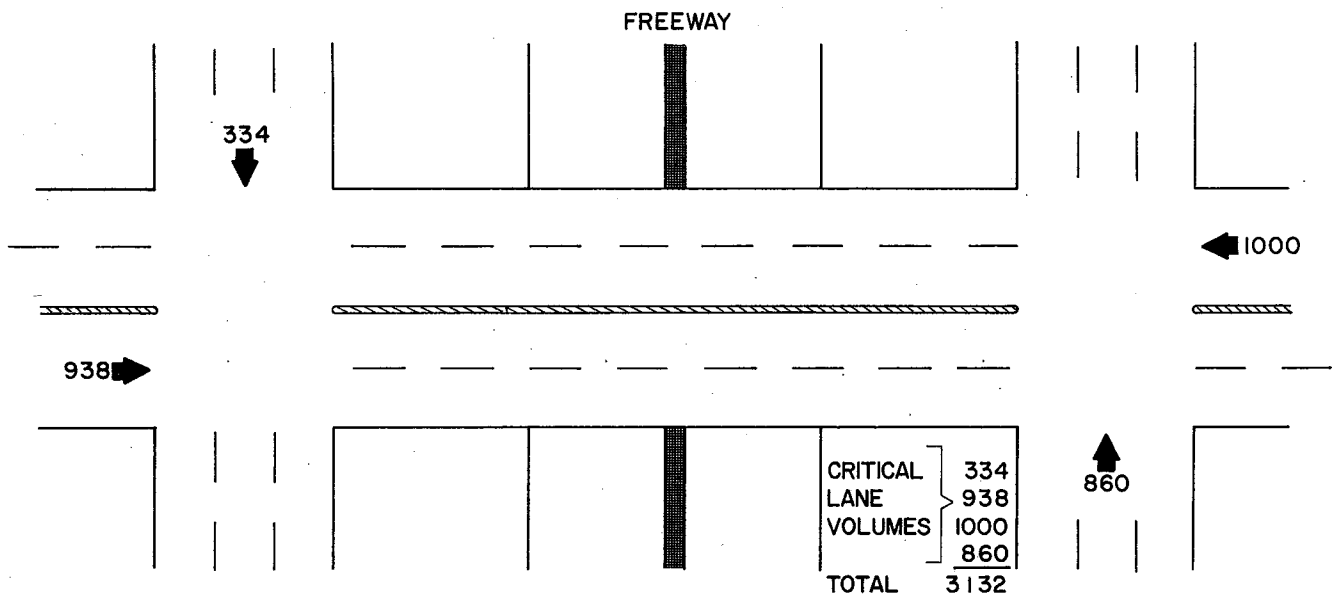

BERRY DATA

AVERAGE CYCLE LENGTH FOR
ACTUATED CONTROLLER = 109 SECONDS

VOLUME AND CYCLE LENGTH COMPARISONS CONVENTIONAL DIAMOND INTERCHANGES

FIGURE 17

Cloverleaf Interchange Travel Time

Studies of the left turn movement on the Cloverleaf interchange (Figure 13) were conducted at the site shown in Figure 5. The cloverleaf studied did not have a collector-distributor road. The travel time for the left turning traffic was found to be related to the following:

1. Rate of flow on the outside lane of the freeway.
2. Rate of flow of left turning vehicles.
3. Loop radius.

Since the vehicles using the loop must merge with the outside lane of the freeway, the capacity of the weaving section becomes very important in any analysis. Since the freeway vehicles have the right of way in the merging area it may be expected that travel time on the loop increases with an increase in the outside freeway lane volume. This is due to a reduction of acceptable gaps in which to merge and a reduction in the loop capacity. This has been shown in Figure 10.

When the rate of flow into the loop exceeds the loop capacity, stack-up occurs. Therefore, the amount of stack-up, or the number of vehicles already in the loop, exerts some influence on travel time. The radius of the loop studied was 100 feet. Under free flow conditions, travel time on the loop was found to be an average of approximately 22 seconds.

As a result, the outside freeway lane volumes, the corresponding loop volume, individual travel times for loop vehicles, and accumulation of stack-up were removed from the film on a per minute basis. It was not possible to study the effect of a larger loop radius since only one study site was available.

A multiple regression was then run on the collected data. This regression produced the following equation:

$$Y = 26.68 - 0.8758 (V_1) + 0.079 (V_1)^2 + 2.448 (s)$$

where

Y = average travel time (sec.),

V_1 = freeway outside lane volume (vpm), and

s = accumulation of vehicles on the loop at the end of the previous minute.

The regression indicated that the above equation would account for approximately 67 percent of the factors influencing loop travel time. It should be noted that loop volume affects loop travel time through the accumulation of vehicles on the loop.

Using the above equation, a family of curves to determine loop travel time was developed and is shown in Figure 18. Use of these curves, by necessity (because of stack-up accumulations) becomes an iterative procedure. This procedure is as follows:

1. Determine rate of flow in outside freeway lane (vpm).
2. Determine rate of flow into loop (vpm).
3. Consult Figure 10 to determine if the loop capacity has been exceeded.
4. The number of vehicles by which the loop capacity has been exceeded plus any stack-up not cleared from previous minutes is the amount of stack-up at the end of each minute.
5. Using the appropriate stack-up curve the average travel time is determined for that minute.
6. The procedure is then repeated for the length of the study period.

It can be observed from the curves in Figure 18 that travel time on the cloverleaf ramp increases rapidly when the left turning traffic exceeds the loop capacity. An example of the travel time for a left turning movement below the loop capacity is given below.

Example (same conditions as examples for diamond interchange)

Freeway Flow outside lane 1200 - veh/hr

Left turn volume - 600 veh/hr

Travel Time

(a) To loop entrance	- 8.5 seconds
(b) Loop travel time	-41.0 seconds
(c) To end of acceleration lane	-13.6 seconds
	<hr/>
Total	63.1 seconds

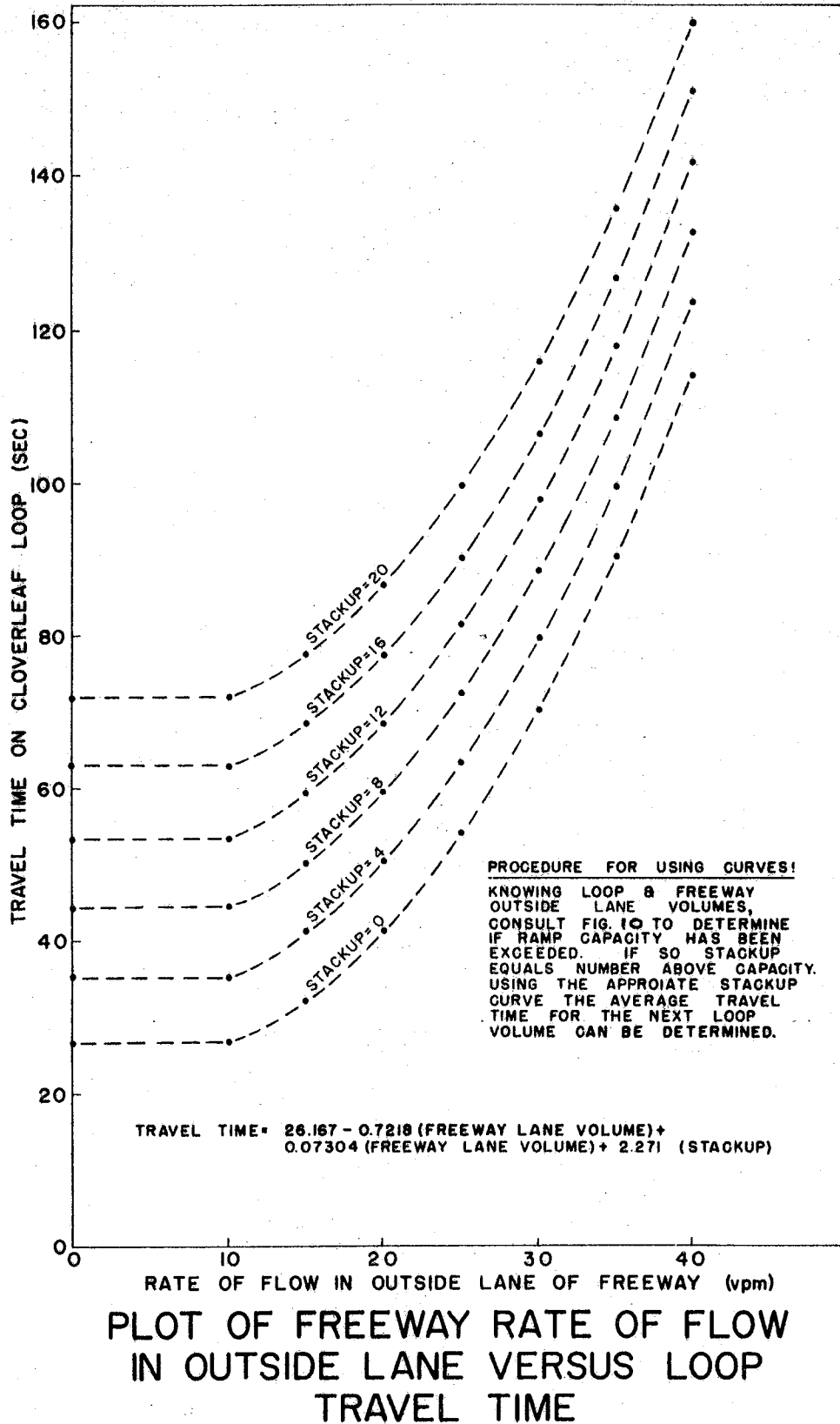

FIGURE 18

For a cloverleaf with collector-distributor roads the loop travel time can be decreased for traffic moving from the major arterial to the freeway.

In summary, it can be stated that the travel time for the left turn movement on a cloverleaf without collector-distributor roads is on the order of 60 seconds, if the left turning volume is less than the loop capacity. With the addition of a collector-distributor road this travel time is reduced to approximately 45 seconds for traffic moving from the major arterial to the freeway. The delay for left turning traffic moving from the freeway to the major arterial would be computed by the same procedure as utilized for the cloverleaf without collector-distributor roads.

INTERCHANGE COST

To facilitate a comparison of the cost between diamond and cloverleaf interchanges it was necessary to develop a standard design situation and then apply a unit cost figure to each cost item for both types of interchanges. In order to include all of the cost items within the confines of the largest interchange area required (outer loops, acceleration and deceleration lanes, and ramps) it was necessary to consider a 4800 foot section of roadway along the freeway and an 1800 foot section of roadway for the arterial streets (see Figure 19) for this cost comparison study.

To serve as a basis for a design, the volume condition shown in Figure 20 was assumed. The number of lanes and the interchange required for both diamond and the cloverleaf were then developed. The estimated average daily traffic shown in Figure 20 was changed to design hourly volume (Figure 21) for both the A.M. and P.M. peaks. Following this an actual flow volume was developed for each element of the diamond and the cloverleaf.

The critical lane design procedure was used in the design of the diamond (Figure 22) and then evaluated to determine the number of lanes needed on the four approaches for both the A.M. and P.M. peaks.

The design of the cloverleaf was considered in two parts (1) the cloverleaf with collector-distributor roads (Figure 23) and (2) the cloverleaf without collector distributor roads (Figure 24). Also shown on Figures 23 and 24 are the actual flow volumes which were developed on the various elements of the cloverleaf for both the A.M. and P.M. peaks.

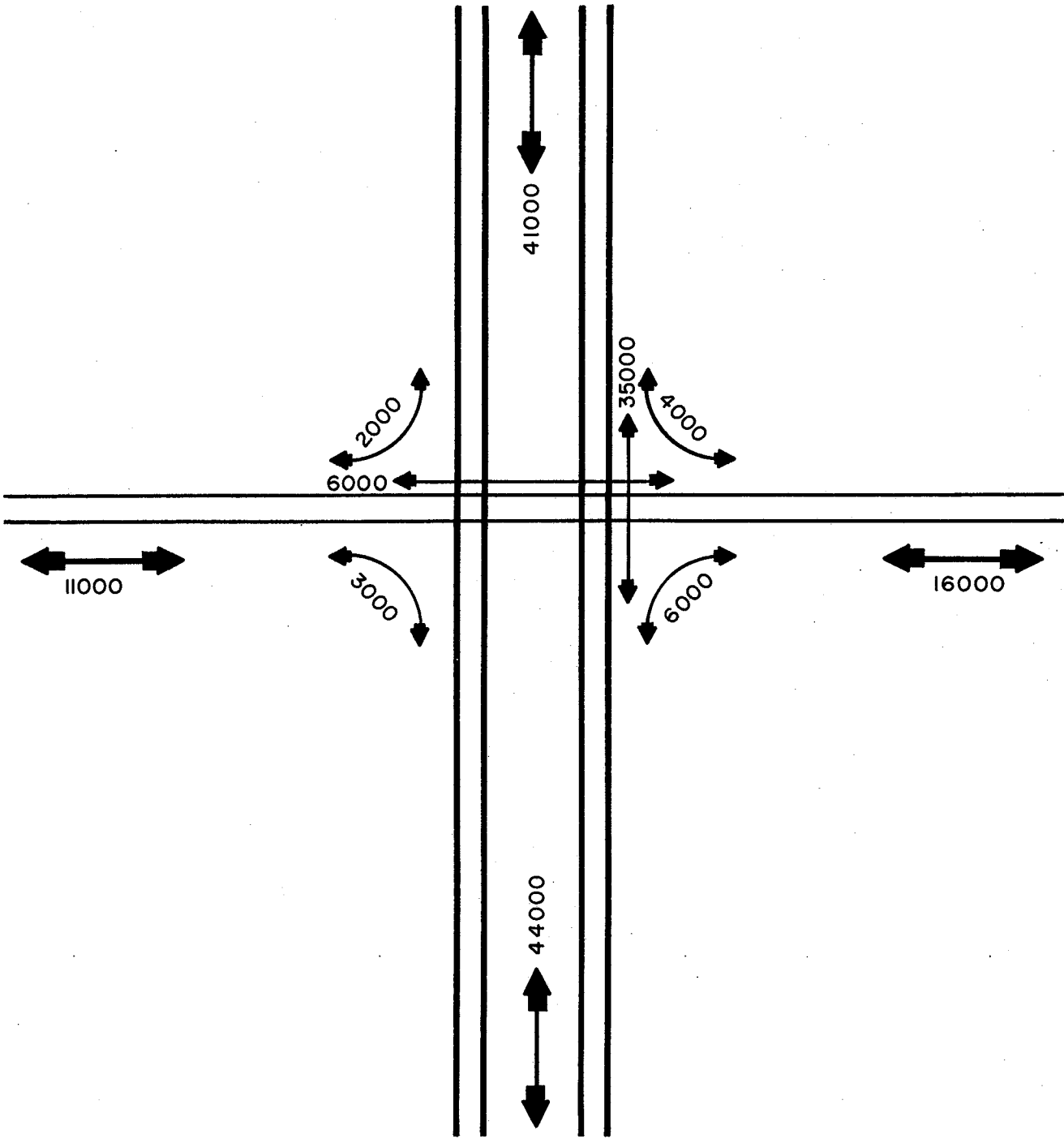

ASSUMED VOLUME CONDITIONS
COST COMPARISON STUDY

FIGURE 19

After considering several methods of determining interchange costs the decision was made to compare the cost of the diamond and the cloverleaf on the following items:

1. Amount of earth work
2. Square footage of bridge involved
3. Square yards of pavement involved
4. Acreages of right-of-way involved

At the present time the exact per cent of the total cost that these four items would represent is not known, but it is estimated that they constitute approximately 80 to 90 percent of the total cost of an interchange. Furthermore, it is believed that the other items such as guard rails, sodding grass, surfacing shoulders, lighting, etc. are minor items and that they will not make an appreciable difference in the total cost. It on this basis that this cost comparison is justified.

Two types of cost estimates were developed. The first was a basic cost which constituted a total cost for all of the stated items within the confines of the largest right-of-way required as shown in Figure 25. The second was an overage cost or a cost to provide an interchange between the freeway and the at-grade arterial. The basic assumption made in connection with the overage cost study was that for any interchange it would be necessary to provide a roadway for both the freeway and the at-grade arterial. Therefore, the cost for design elements required for interchange (loops in case of cloverleaves and ramps for diamonds) could be estimated separately as overage cost. Tabulations of total interchange quantities and estimated basic overage cost for each item of the diamond and cloverleaf appear in Table A. It should be noted that in Table A the total basic pavement for the cloverleaf without collector-distributor roads is less than the diamond or the cloverleaf with collector-distributor roads. The quantity of pavement is less for the cloverleaf without collector-distributor roads because for the frontage roads are discontinued at the outer loops as shown in Figure 25.

The volume of earthwork, the square footage of bridges, the square yards of pavement, and the acres of right-of-way were computed utilizing the maximum width of the typical freeway sections shown in Figure 26 i.e. a six lane divided freeway, three lane frontage roads, and four lane arterial streets. A maximum of four per cent grade was used in the design of the diamond and the cloverleaf as shown in Figure 27. The end areas were computed using $A + H(w+3H)$, a formula derived from the chart

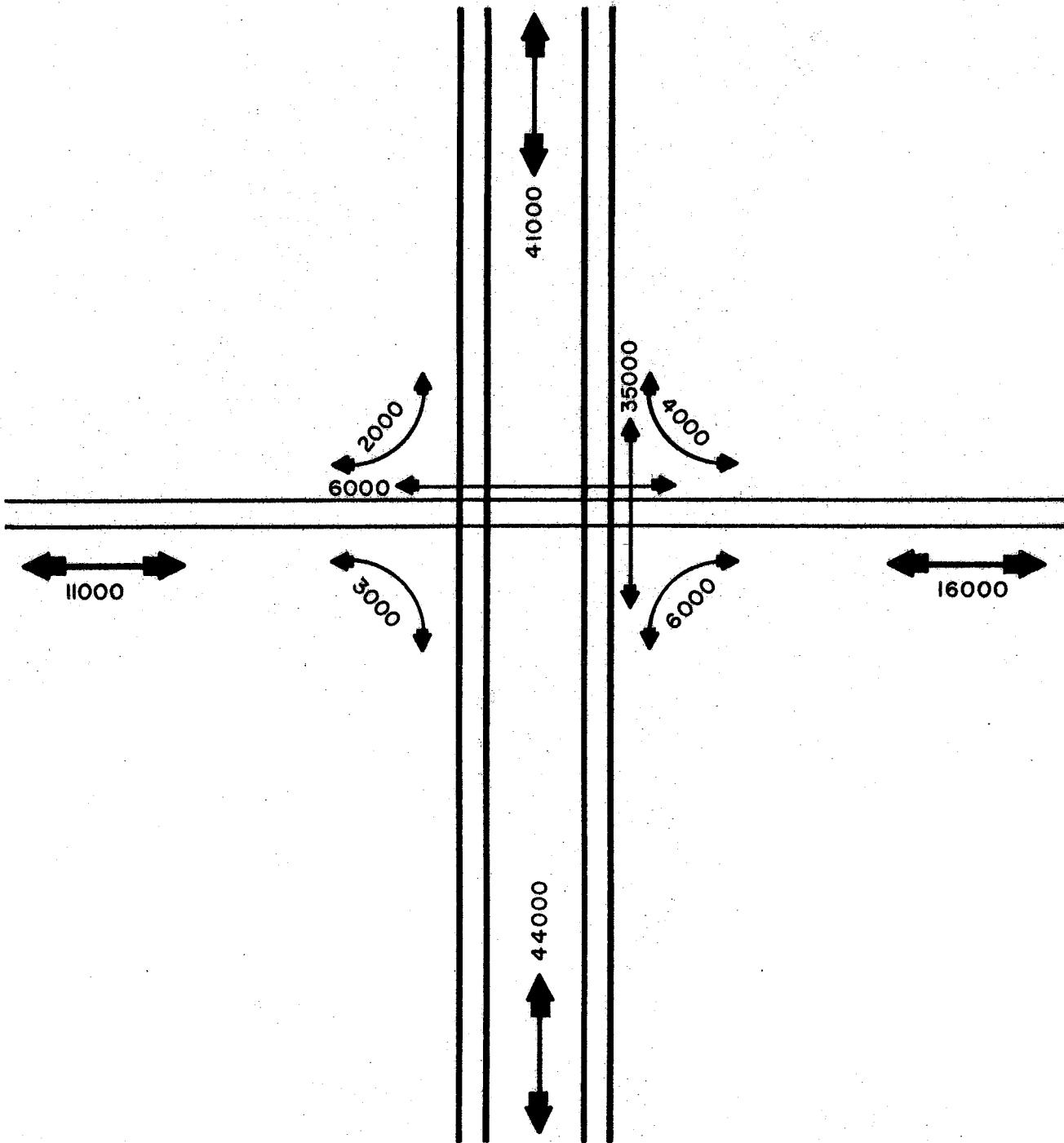

ASSUMED VOLUME CONDITIONS
 COST COMPARISON STUDY

FIGURE 20

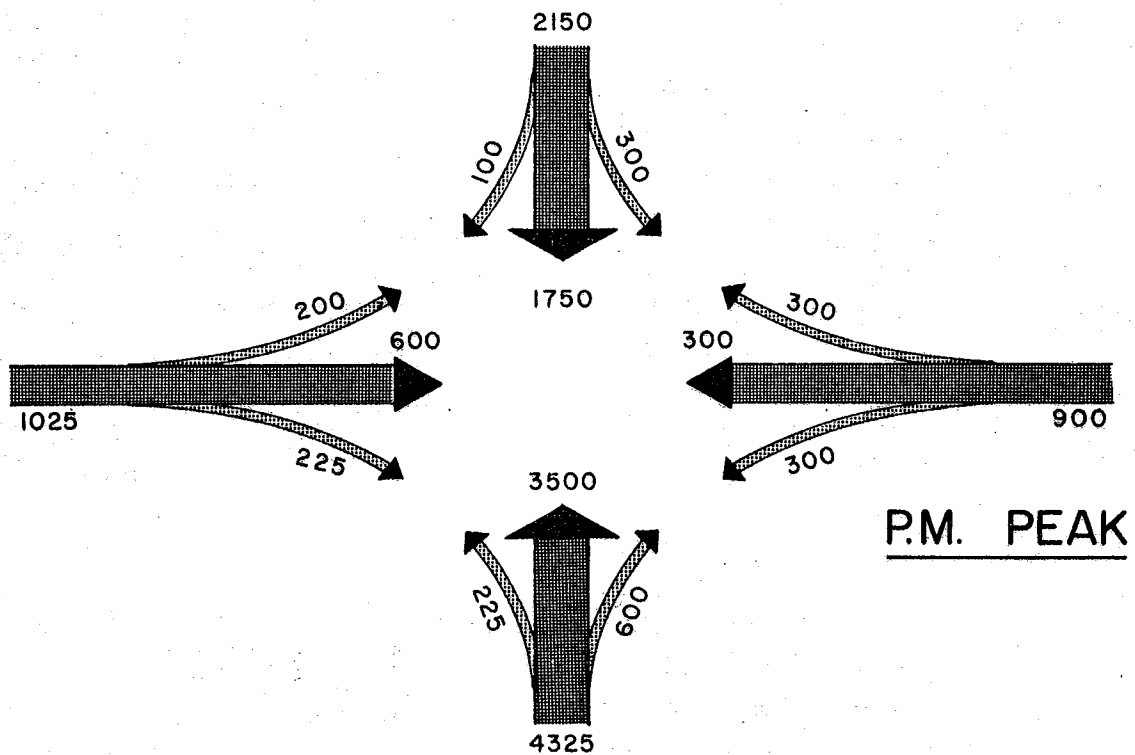
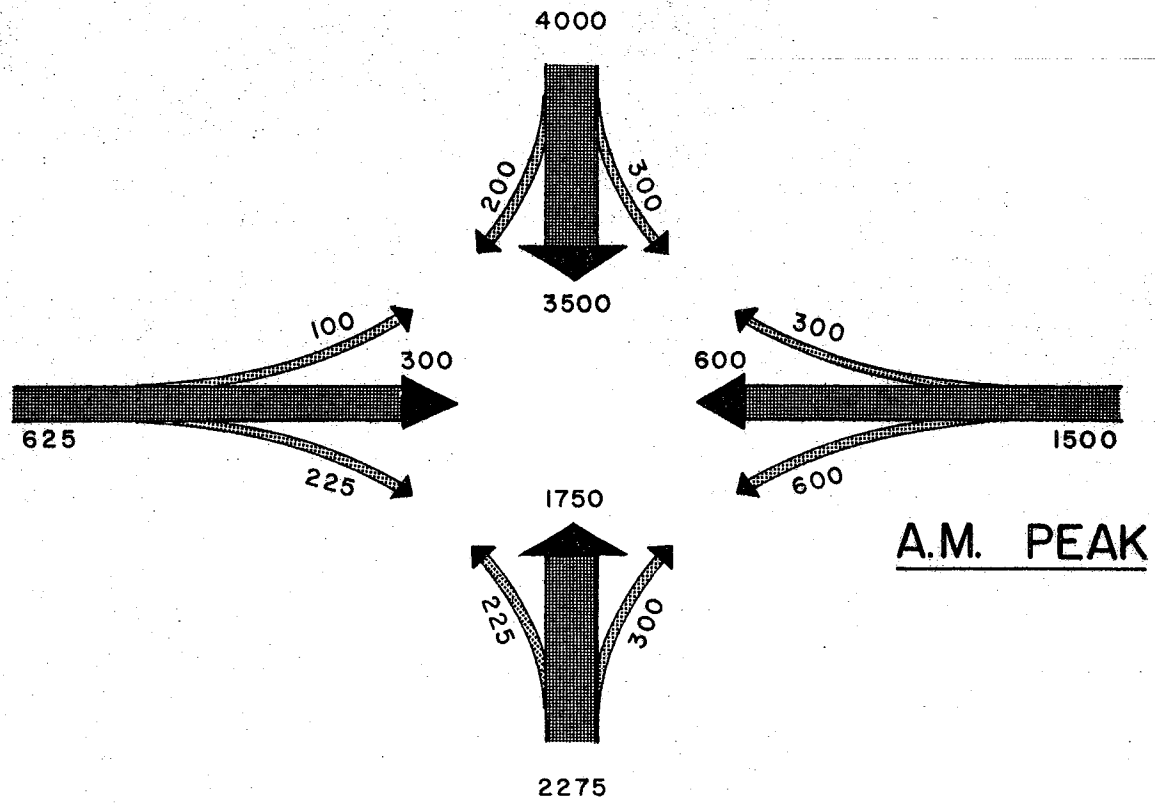

DESIGN HOURLY VOLUMES
 COST COMPARISON STUDY

FIGURE 21

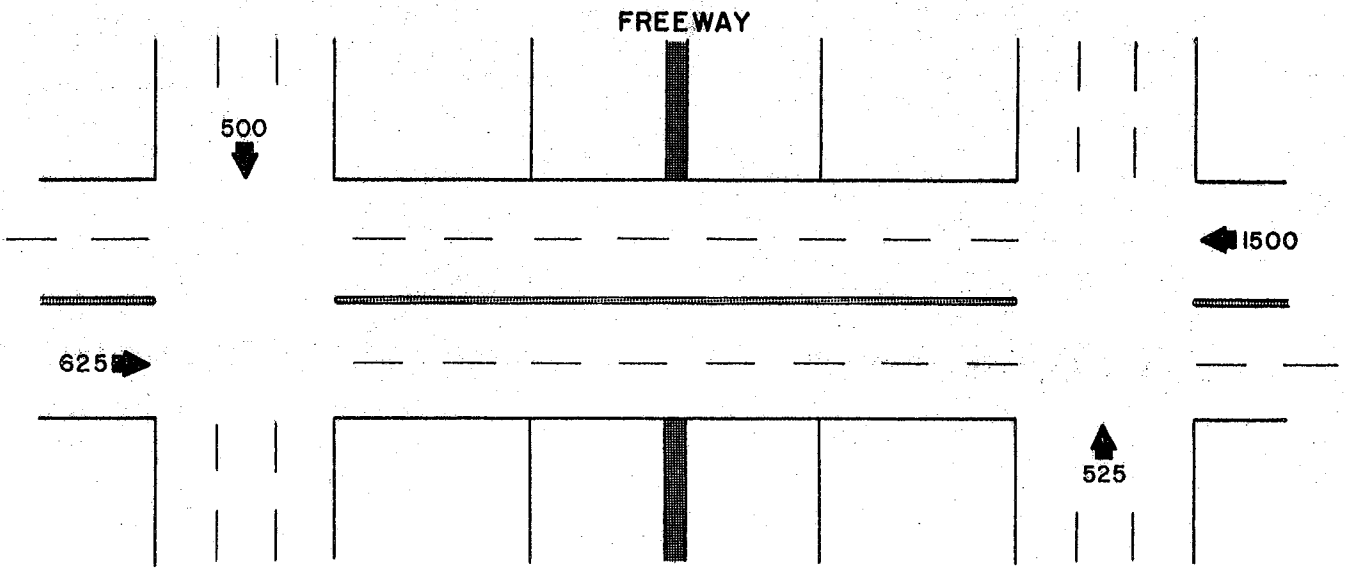

A.M. PEAK

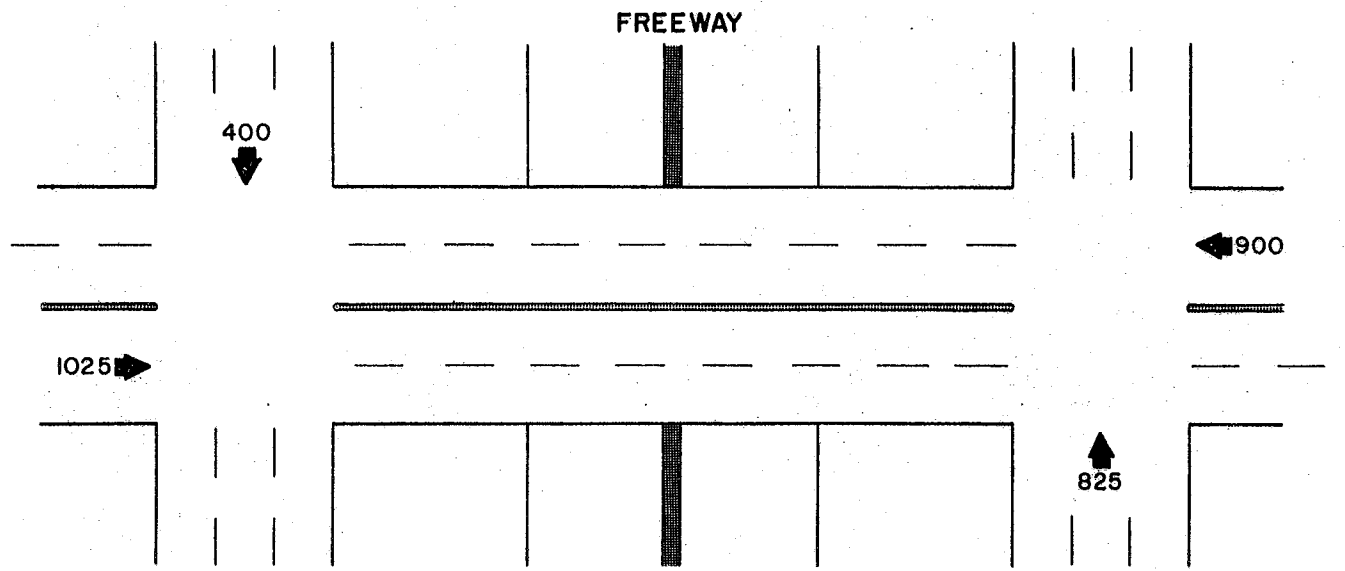

P.M. PEAK

**DIAMOND INTERCHANGE DESIGN
COST COMPARISON STUDY**

FIGURE 22

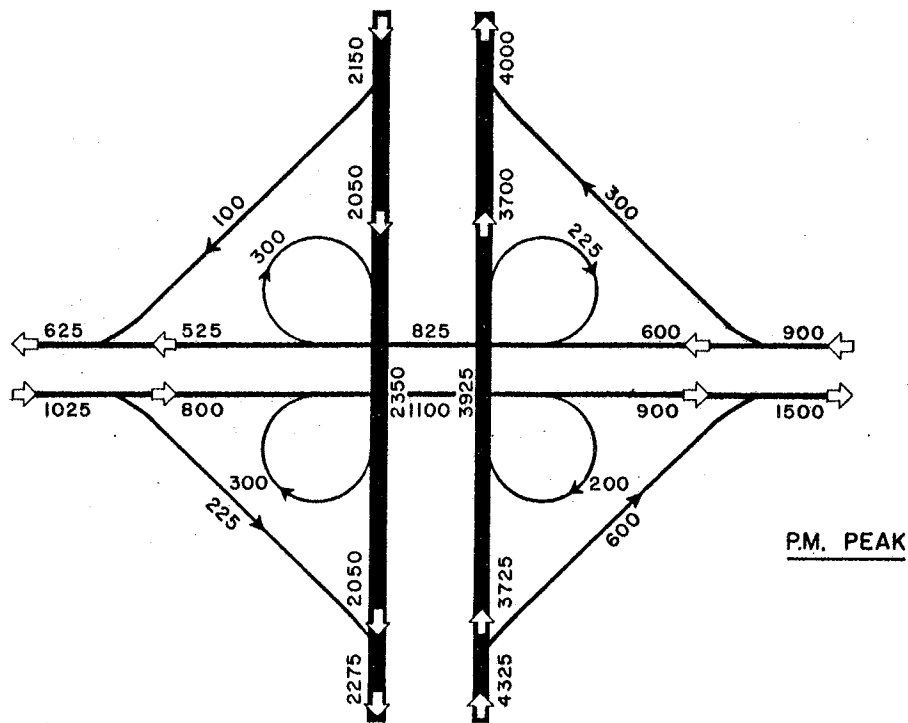
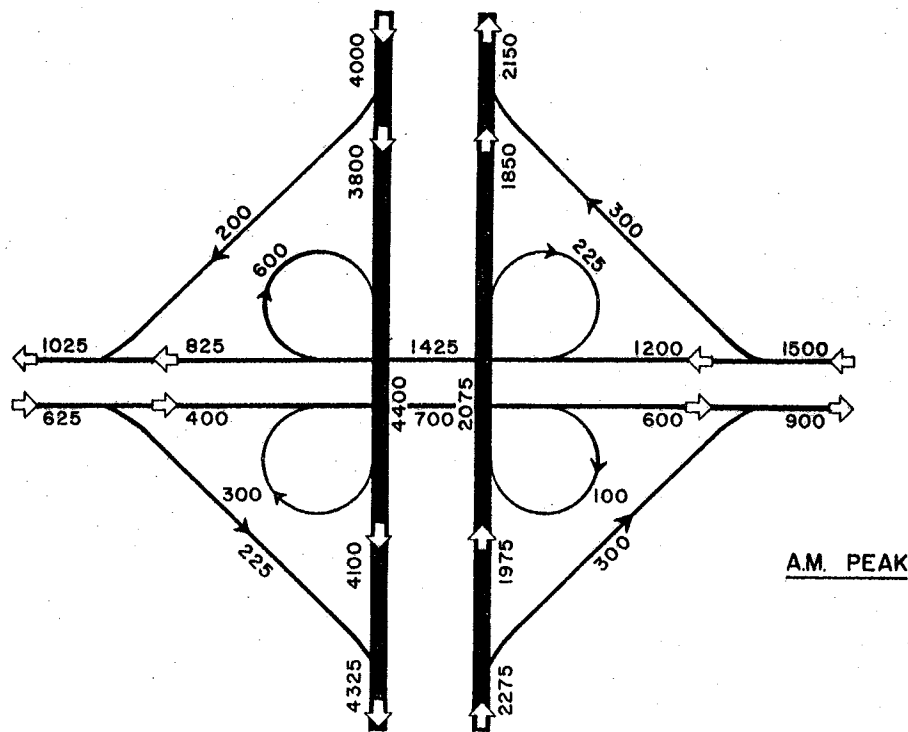

CLOVERLEAF INTERCHANGE WITHOUT
COLLECTOR-DISTRIBUTOR ROADS
COST COMPARISON STUDY

FIGURE 24

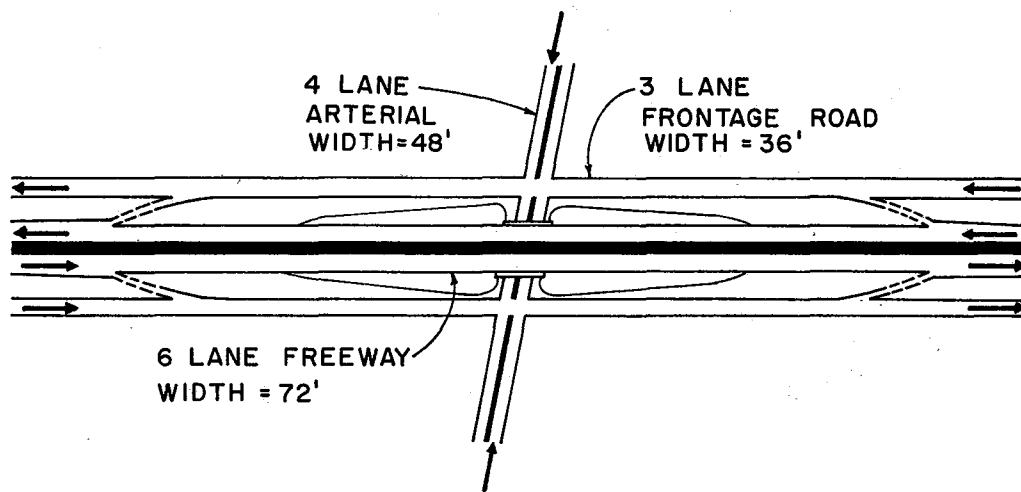

BASIC REQUIREMENTS FOR DIAMOND AND CLOVERLEAF WITH COLLECTOR - DISTRIBUTOR ROADS

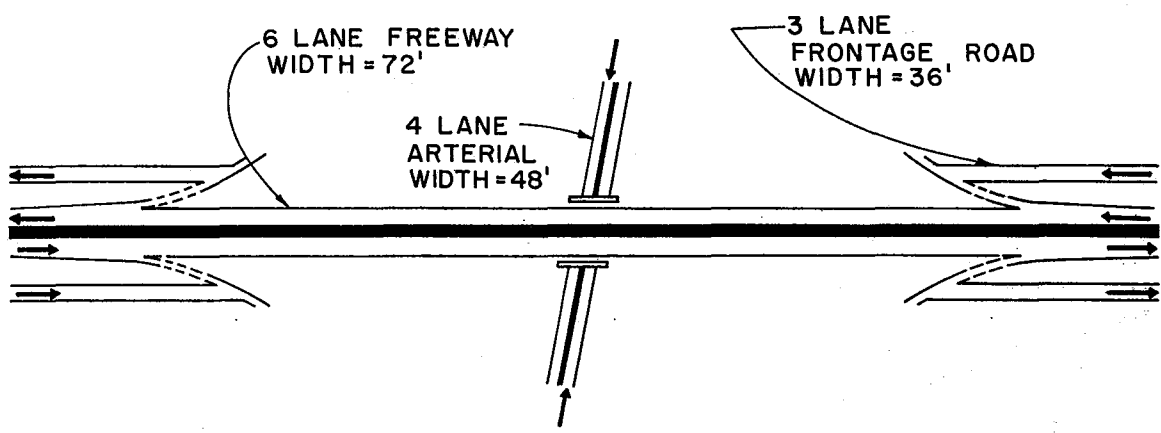

BASIC REQUIREMENTS FOR A CLOVERLEAF WITHOUT COLLECTOR - DISTRIBUTOR ROADS

DESIGNS CONSIDERED FOR DETERMINING BASIC COSTS

FIGURE 25

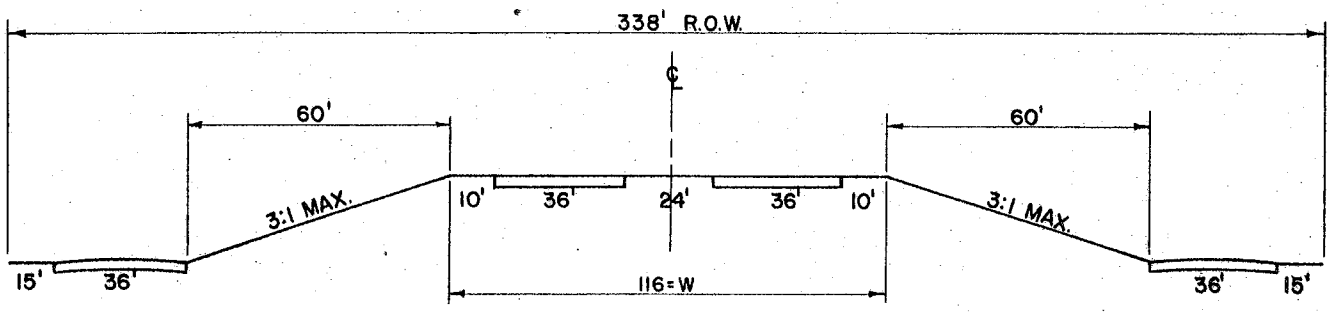

TYPICAL SIX LANE FREEWAY SECTION

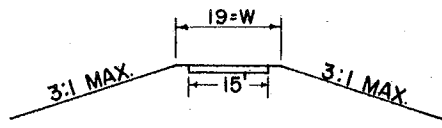

TYPICAL RAMP SECTION

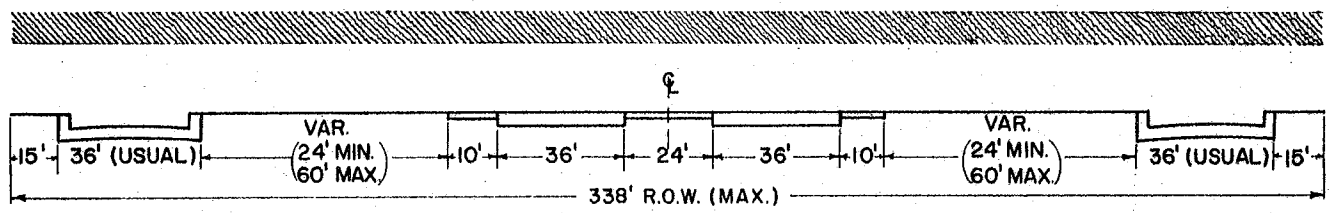

TYPICAL SIX LANE FREEWAY SECTION WITH COLLECTOR-DISTRIBUTOR ROADS

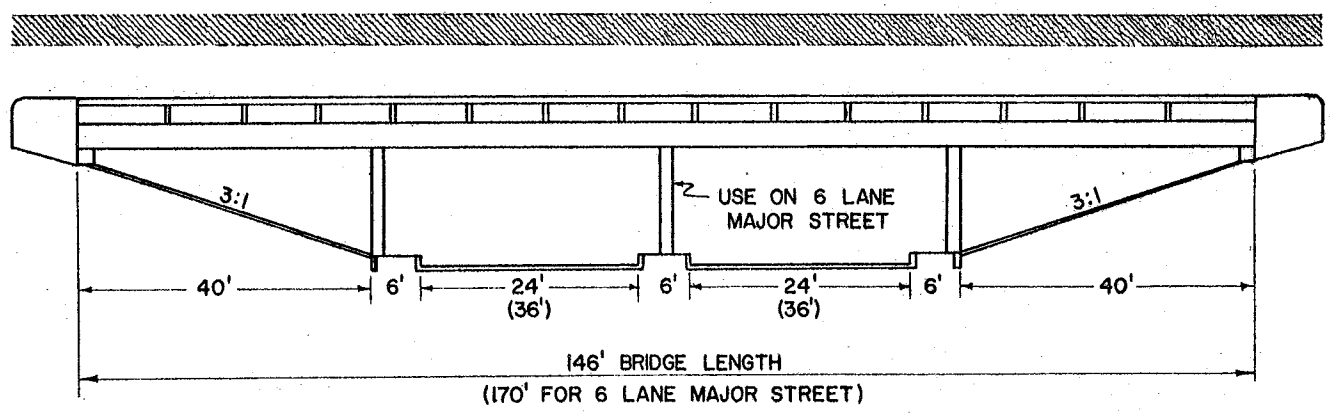

TYPICAL FREEWAY OVERPASS (TYPICAL MAJOR STREET SECTION UNDERPASS)

**DESIGN CONSIDERATIONS
COST COMPARISON STUDY**

P.I. STA. 0+00
ELEV. = 2700'
V.C. = 900'
e = 9.00'

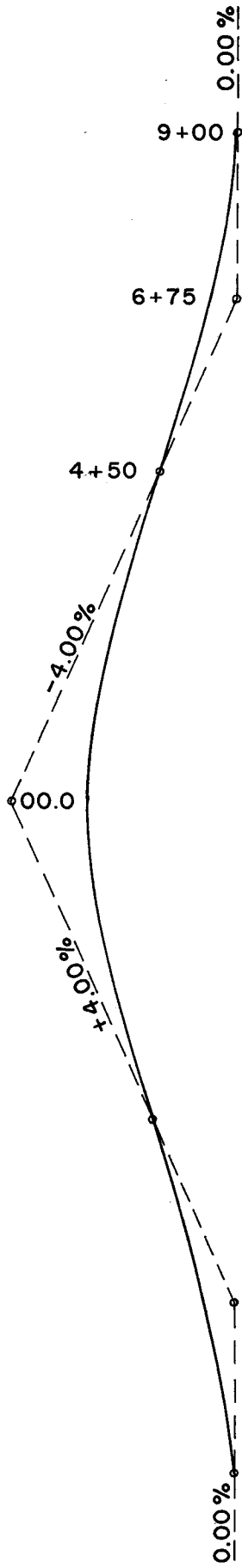

P.I. STA. 6+75
ELEV. = 0.00
V.C. = 450'
e = 2.25'

(K. MIN. = 112.5)

MAXIMUM GRADE CONSIDERED IN INTERCHANGE DESIGN

FIGURE 27

shown in Figure 28. A comparison of the cost and volume of earthwork for the diamond and the cloverleaf is summarized in Table B. The volumes of earthwork shown in this table were computed using the above formula $A = H(w+3H)$.

The unit price of each item included in this cost comparison was obtained by taking an average cost of each item from several interchanges that have been built. The unit process used was as follows:

Earthwork - \$1.30 per cubic yard

Bridges - \$7.00 per square foot

Pavement - \$5.00 per square yard

Right-of-way - \$5,000 per acre

It should be noted that the unit prices for both the basic and the overage cost are the same with the exception of the pavements. A unit price of \$6.00 per square yard was used for the overage cost on the pavement since ramps would require additional grading and form work. The prices of each item listed above is an average cost obtained from past experience. Since these costs were used for both the diamond and the cloverleaf cost calculations the general cost comparisons would not be greatly affected if they are slightly in error. If the procedure outlined is utilized in future interchange cost studies, it is suggested that the best current price estimates available be utilized.

Since the price of right-of-way is a major cost item in the total cost of an interchange and since it is very difficult to obtain an average right-of-way cost that would apply in all situations, it was felt desirable to compute a family of right-of-way cost curves (Figure 29) which would show the relationship between the cost of the various types of interchanges, and the effect of right-of-way on the total cost for each type of interchange. Since the estimated unit price for earthwork, bridges, and pavement is essentially a standard figure, the effect of various costs of right-of-way on the total interchange cost is of particular interest. It should be noted that the right-of-way cost curves shown in Figure 29 were developed utilizing the estimated unit prices as outlined in this cost comparison study and that a similar set of curves should be developed if more current prices are utilized.

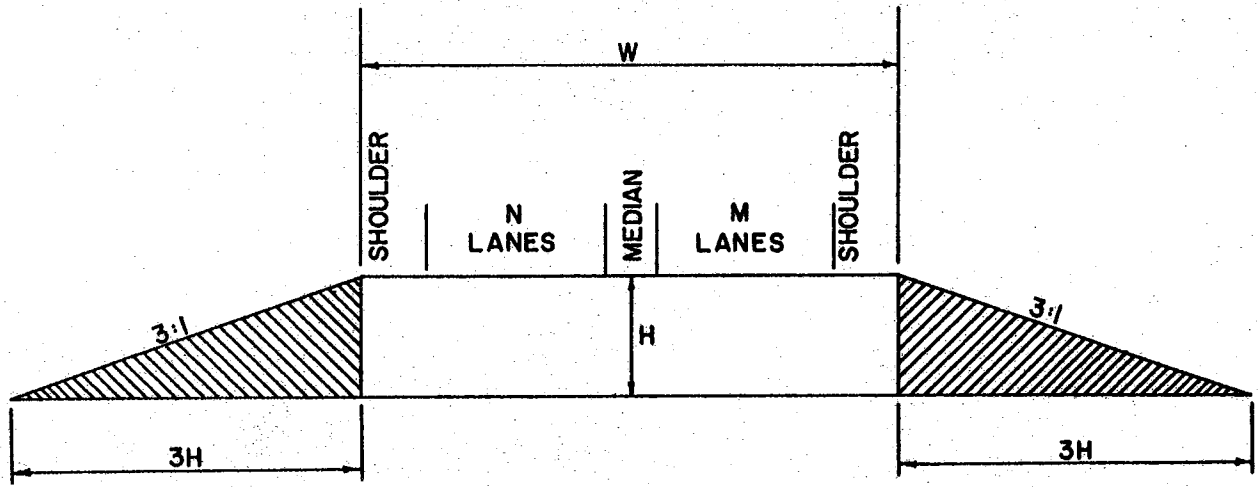

$$A = WH + 3H^2 = H(W + 3H)$$

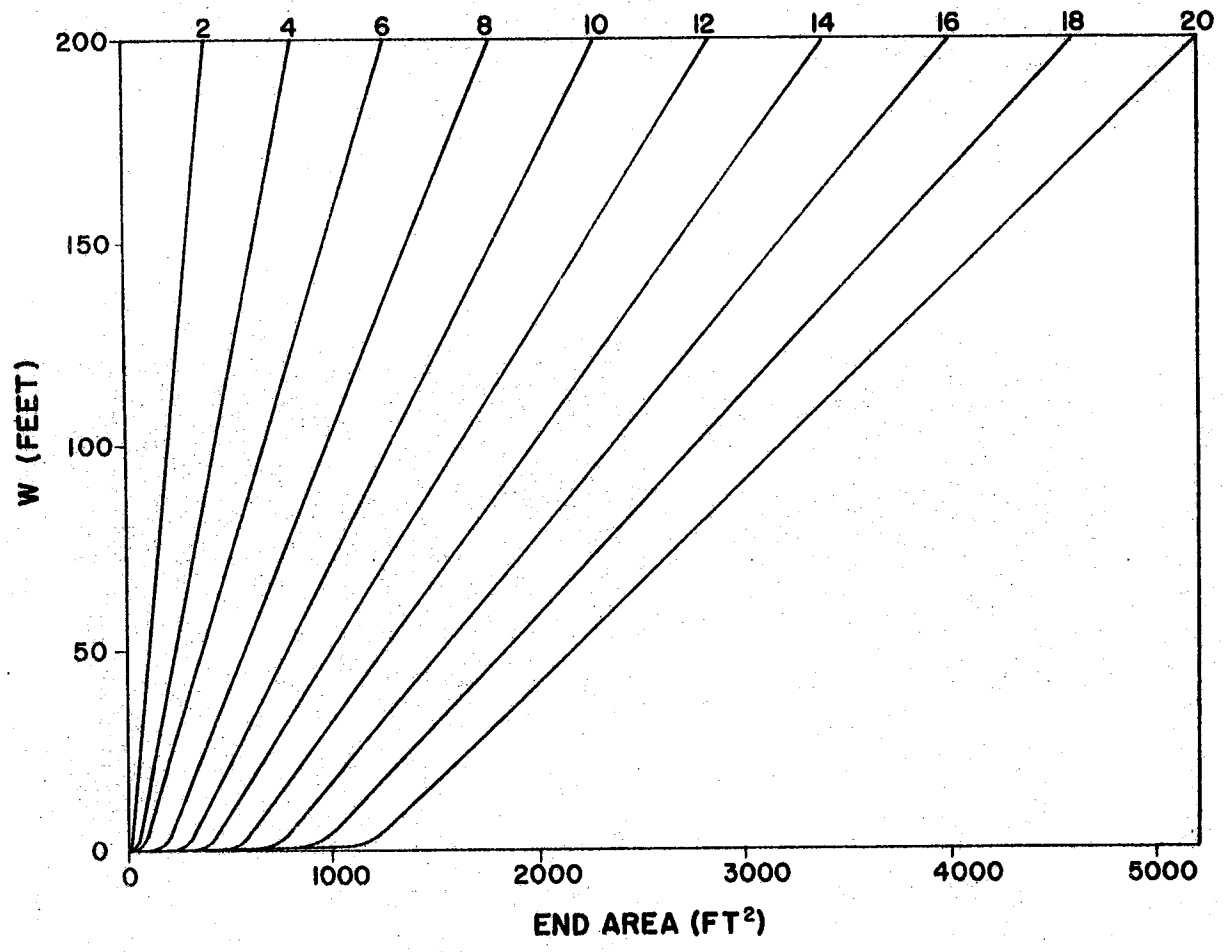

END AREA COMPUTATIONS CHART
COST COMPARISON STUDY

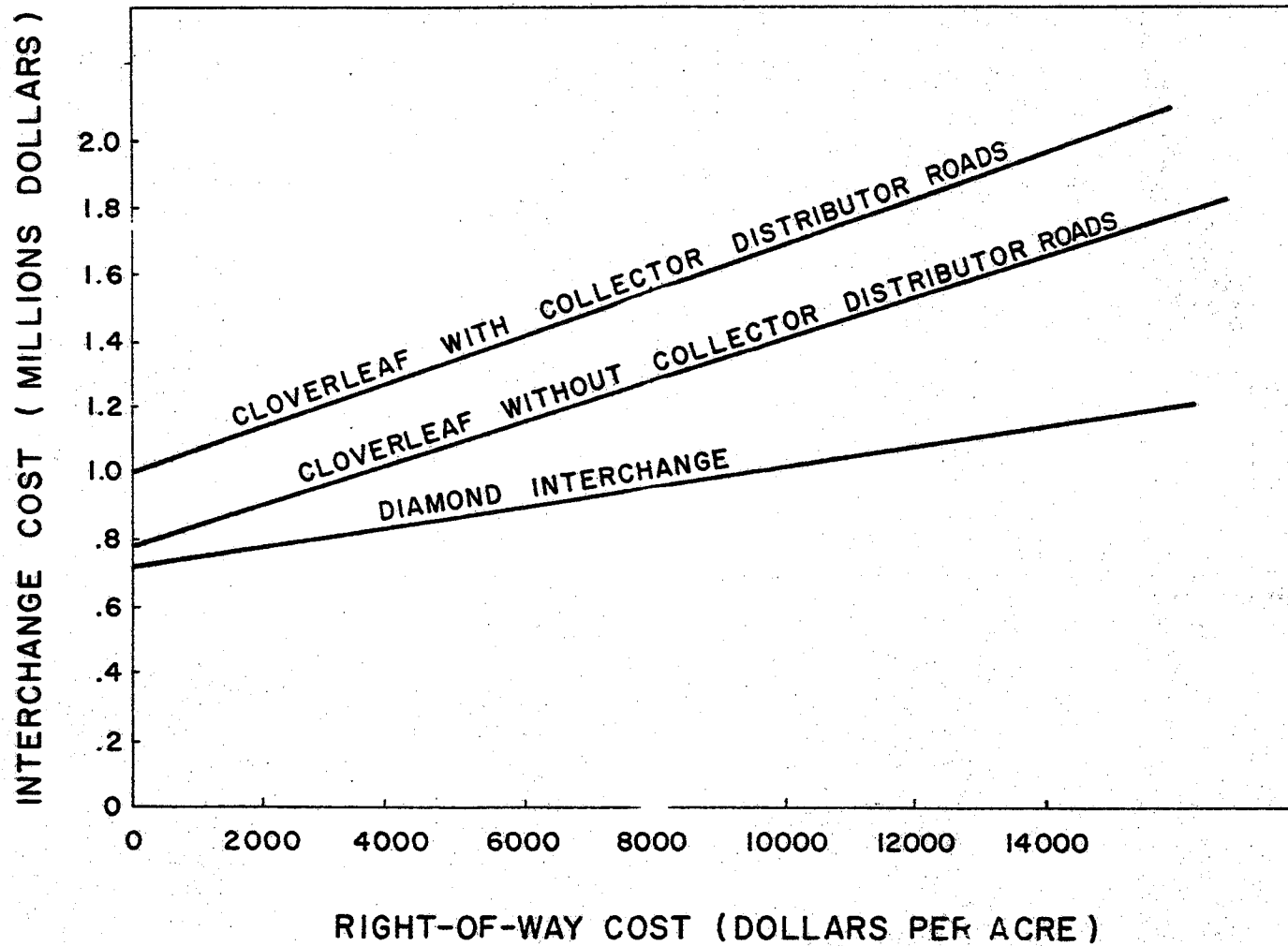

EFFECT OF RIGHT-OF-WAY COST ON INTERCHANGE COST

FIGURE 29

SUMMARY AND CONCLUSIONS

The research work on the project "Ramps and Interchanges" has included studies of entrance ramp operation, diamond interchange signalization and operation and cloverleaf operation. This report has presented data from comparative studies of diamond and cloverleaf interchanges which considered the factors of capacity, efficiency and cost.

It is felt that the results of the previous studies, as listed in the introduction plus the comparative data presented in this report, provide a factual guide to the selection and design of nondirectional interchanges. Since any interchange design problem presents individual problems related to specific volume and location factors, it is not possible to say that one interchange type is superior to another. However, it is possible with the data presented, to make factual comparisons of capacity efficiency and cost along the lines suggested in this report and to select the type interchange which will do the best job for the given design situation.

TABLE A

ITEM	TYPE OF INTERCHANGE					
	DIAMOND		CLOVERLEAF			
			WITHOUT COLLECTOR-DISTRIBUTOR ROADS		WITH COLLECTOR-DISTRIBUTOR ROADS	
	QUANTITY	COST	QUANTITY	COST	QUANTITY	COST
EARTHWORK (BASIC)	19,198 CU.YD.	\$ 24,950.00	16,613 CU.YD.	\$ 21,600.00	19,198 CU.YD.	\$ 24,950.00
EARTHWORK (OVERAGE)	79,740 CU.YD.	103,662.00	97,146 CU.YD.	126,200.00	150,248 CU.YD.	195,200.00
BRIDGE	19,720 SQ.FT.	138,040.00	23,800 SQ.FT.	166,700.00	40,800 SQ.FT.	285,000.00
PAVEMENT (BASIC)	86,000 SQ.FT.	430,000.00	72,000 SQ.FT.	360,000.00	86,000 SQ.FT.	430,000.00
PAVEMENT (OVERAGE)	32,000 SQ.FT.	19,200.00	19,917 SQ.FT.	119,700.00	15,267 SQ.FT.	91,602.00
RIGHT-OF-WAY (BASIC)	39.9 AC.	199,500.00	39.9 AC.	199,500.00	39.9 AC.	199,500.00
RIGHT-OF-WAY (OVERAGE)	0.0 AC.		20.9 AC.	104,500.00	26.4 AC.	132,000.00
TOTAL BASIC COST		\$ 654,450.00		\$ 581,100.00		\$ 654,450.00
TOTAL OVERAGE COST		260,902.00		517,100.00		703,802.00
TOTAL COST		\$ 915,352.00		\$ 1,098,200.00		\$ 1,358,252.00

TOTAL QUANTITIES
COST COMPARISON STUDY

TABLE B

AMOUNT AND TYPE OF EARTHWORK	TYPE OF INTERCHANGE		
	DIAMOND	CLOVERLEAF	
		WITHOUT COLLECTOR-DISTRIBUTOR ROADS	WITH COLLECTOR-DISTRIBUTOR ROADS
FILL FOR OVERPASS	79,740 CU. YD.	89,882 CU. YD.	143,300 CU. YD.
FILL FOR LOOPS		7,264 CU. YD.	6,947 CU. YD.
AT-GRADE INTERSECTION	19,198 CU. YD.	16,613 CU. YD.	19,198 CU. YD.
TOTAL FILL	98,938 CU. YD.	113,759 CU. YD.	169,446 CU. YD.
TOTAL COST OF EARTHWORK	\$128,619.00	\$147,800.00	\$220,150.00

EARTHWORK QUANTITIES
COST COMPARISON STUDY

