

E F F E C T S   O F   O F F - R A M P S  
O N   F R E E W A Y   O P E R A T I O N

by

William E. Tipton  
James D. Carvell  
and  
Charles Pinnell

Research Report Number 59-4 (Final)

Off-Ramps on Freeway Operation  
Research Project Number 2-8-63-59

Sponsored by  
The Texas Highway Department  
In Cooperation with the  
U. S. Department of Commerce, Bureau of Public Roads

October 1965

TEXAS TRANSPORTATION INSTITUTE  
Texas A&M University  
College Station, Texas



TABLE OF CONTENTS

Summary . . . . . iii

Research Report Number 59-1--THE EFFECTS OF OFF-RAMPS  
ON FREEWAY OPERATION AS RELATED TO DECELERATION  
DISTANCE AND OFF-RAMP CAPACITY . . . . . 9

Research Report Number 59-2--THE EFFECTS OF OFF-RAMPS  
ON FREEWAY OPERATION AS RELATED TO SHORT TRIP  
GENERATION, WEAVING MANEUVERS, AND ACCESS  
CONTROL . . . . . 52

Research Report Number 59-3--THE EFFECTS OF OFF-RAMPS  
ON FREEWAY OPERATION AS RELATED TO ACCESS  
PROVISION . . . . . 73



EFFECTS OF OFF-RAMPS  
ON FREEWAY OPERATION  
SUMMARY

by

Charles Pinnell



## INTRODUCTION

Studies have indicated that the off-ramp is a critical element of a freeway facility and can contribute significantly to both desirable and undesirable operations. If maximum efficiency is to be obtained from a freeway, the off-ramps must be located, designed, and operated to minimize any adverse effects on main-lane freeway flow and to permit maximum utilization of the facility. The original objectives of the off-ramp project were to evaluate the effect on freeway operation of (1) the frequency of off-ramps and (2) various arrangements of off-ramps. Studies of the off-ramp problem led to the conclusion that the objective of the off-ramp project should be expanded to study the total effect of off-ramps rather than the more narrow scope of considering only frequency and arrangement. Consideration of the problem resulted in the definition of several factors of off-ramp location, design, and operation that could affect the operation of the freeway. These factors are enumerated as follows: (1) deceleration distance, (2) off-ramp capacity, (3) short trip generation, (4) weaving maneuvers, (5) access control, and (6) access provision.

Research on the off-ramp project was directed toward an investigation of each of the above factors. A brief discussion of the studies conducted in connection with each factor is presented in the following sections.

### Deceleration Distance

Previous research has shown that an inadequate deceleration distance on an off-ramp can cause exiting vehicles to decelerate before leaving the main lanes of the freeway. This deceleration can cause shock waves to be generated near the exit ramp and propagated upstream on the freeway. The shock waves can constitute an accident hazard and reduction in the operating efficiency.

Since insufficient data existed from which to evaluate the effects of deceleration distances, studies were designed to investigate these effects. Sites on the Gulf Freeway in Houston and on IH 35 in Fort Worth were chosen for study locations and motion picture and acceleration noise studies were conducted.

### Off-Ramp Capacity

Off-ramp capacity is defined here as the ability to move vehicles from the main freeway lanes to a service road or city street. If inadequate ramp capacity exists at a given location then queues may form causing stalled traffic to back onto the main lanes of the freeway. This creates a very undesirable situation on the freeway and could be one serious effect of off-

ramp operation.

Inadequate ramp capacity can result from several conditions. These conditions are as follows:

1. Signalized intersections located in the near proximity of the off-ramp terminal. Traffic queuing against a red signal indication can backup and block the off-ramp movement.
2. Where high volume frontage roads exist, it may become difficult to move from the off-ramp into the frontage road stream.
3. Two or more lanes are sometimes provided on the off-ramp near the exit from a freeway and these lanes then merge into a single lane or diverge into two separate roadways a short distance from the freeway exit point. The necessity to weave into a single lane or into the proper lane for a diverging maneuver can create capacity problems.

After considering the above three cases, it was determined that information existed for conditions 1 and 3 but that no design data were available for condition 2. Research studies were thus directed toward developing capacity-design data which would permit the designer to consider off-ramp capacity. Studies of this capacity aspect were conducted utilizing a computer simulation program.

#### Short Trip Generation

The generation of short trips on a freeway tends to destroy its integrity as a long trip facility and could seriously affect traffic flow during peak periods. It was thus deemed necessary to investigate the amount of short trip generation on freeways with frequent ramps. Data on the origin and destination of ramp traffic on the Gulf Freeway in Houston and the North Central Expressway in Dallas were obtained to evaluate short trip generation.

#### Weaving Maneuvers

As the frequency of entrance and exit ramps on a freeway increases the length of weaving sections between entrance and exit ramps decreases which could create a weaving problem. The extent of weaving that may occur in a given freeway section due to the distribution of vehicles over the freeway lanes and the desired exit movements was not well documented and this project sought to study this factor. A "Lights On" study conducted on the North Central Expressway in Dallas which provided lane use data on individual vehicles utilizing the freeway was used for this purpose.



## Access Control

The problem of access control on exit ramps has been brought to the attention of the public by numerous spectacular crashes involving vehicles which entered an exit ramp travelling in the wrong direction, and became involved in a head-on crash with vehicles moving in the opposite direction. The studies in this phase sought to define the extent of the problem by a review of current literature and the collection of data on violations of this type. Types and designs of directional detectors for possible use in data collection were also considered.

## Access Provision

The basic need for the freeway off-ramp is, of course, to provide access to abutting property and to provide connections to major arterials of a city's distribution system. Early considerations of this factor indicated that a question existed as to how this access provision and major arterial connection should be made. There are various forms of exit and entrance ramp configurations in use but little attention has been given to the effect of these configurations on freeway operation.

Two common interchange configurations are the Diamond-Type and the X-type Interchange. A third type which has been utilized to a lesser extent is the "Stacked Ramp" configuration which crosses entrance and exit movements by the use of a grade separation. It was found that very little factual data existed to guide the designer in the selection of these types.

In order to consider the effect of ramp arrangement and interchange configuration, studies of traffic desires at interchanges, freeway gap availability, and geometric requirements were conducted. The Gulf Freeway in Houston provided study locations for the collection of operational data.

## Presentation of Results

Research work on the project was divided into three basic areas which were as follows:

1. Investigation of the effects of Off-Ramps on Freeway Operation as Related to Deceleration Distance and Off-Ramp Capacity.
2. Investigation of the Effects of Off-Ramps on Freeway Operation as Related to Short-Trip Generation, Weaving Maneuvers, and Access Control.
3. Investigation of the Effects of Off-Ramps on Freeway Operation as Related to Access Provision.

The studies and specific findings for each of these areas will be discussed in separate sections of this report.

### Summary Conclusions

As a result of the research studies conducted to evaluate the previously discussed factors, the following general conclusions were drawn:

1. Off-ramps do exhibit an effect on freeway operation as indicated by speed and acceleration noise measurements. However, in all cases studied this effect was not exceedingly severe and the extent was directly related to the design of the off-ramp. Well designed off-ramps showed considerably less effect than those of less adequate design.
2. Studies of off-ramp capacity pointed to the need for data on merging capacities of off-ramp and frontage road flow. Where frontage road volumes are heavy and where no priority of right-of-way assignment is given to the off-ramp traffic the capacity of the ramp is quite low. This condition can create ramp queues which back into the freeway and seriously affect freeway flow. Through the use of a simulation model, design curves were developed which permit the consideration of possible queue lengths for various traffic conditions.
3. Short trip generation on a freeway is not a serious problem and mainly results from discontinuous frontage roads or difficult surface street routing.
4. Frequent exit ramps do not appear to create serious weaving problems at individual exit locations. Traffic tends to move to the outside lane of the freeway well in advance of the exit point which eliminates the undesirable effect of last-minute weaves across intervening freeway lanes.
5. The problem of wrong-way entries on off-ramps is a serious one and merits special studies to develop design and/or controls for its elimination.
6. Traffic studies at interchanges indicated a wide variation of desired traffic movements resulting from land development in the area and the existing surface street configuration. It was thus deemed desirable to make provisions for both an on- and off-ramp in the near vicinity of and in each quadrant of an arterial street interchange as shown in Figure 1. If either the on- or off-ramp in any given quadrant cannot be justified in the initial design, then design considerations should be made which would allow stage construction of the ramp at some later date when traffic conditions warrant its construction.

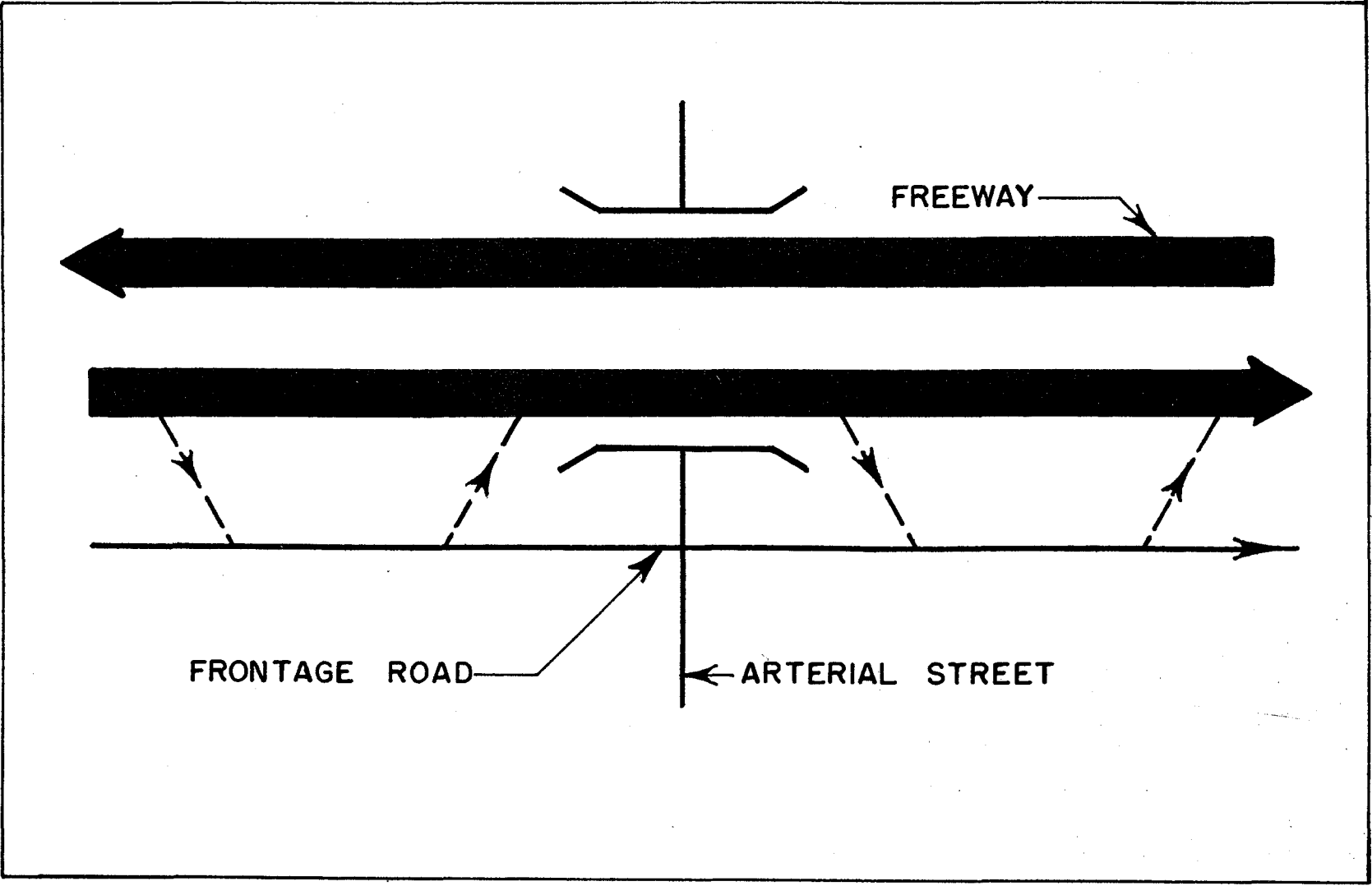

INTERCHANGE LAYOUT

FIGURE I

7. Studies of freeway operation, access to abutting property and intersection operation resulted in the conclusion that the most desirable arrangement of ramps is as shown in the freeway layout in Figure 2. This layout maximizes gap availability for on-ramp traffic, provides more direct access to abutting properties, eliminates unnecessary traffic flow through the signalized intersections (frontage road-arterial street) and provides maximum storage space for traffic entering the freeway or waiting against a red indication at a signalized intersection.
  
8. The type layout recommended in number 7 above could create weaving problems on the frontage road when heavy exit and entrance ramp flow exist adjacent to each other. This difficulty could be overcome by the use of a "stacked" ramp arrangement such as shown in Figure 3. Studies of the "stacked" ramp geometrics indicated that such ramp arrangements would not generally be feasible unless warranted by especially high traffic.

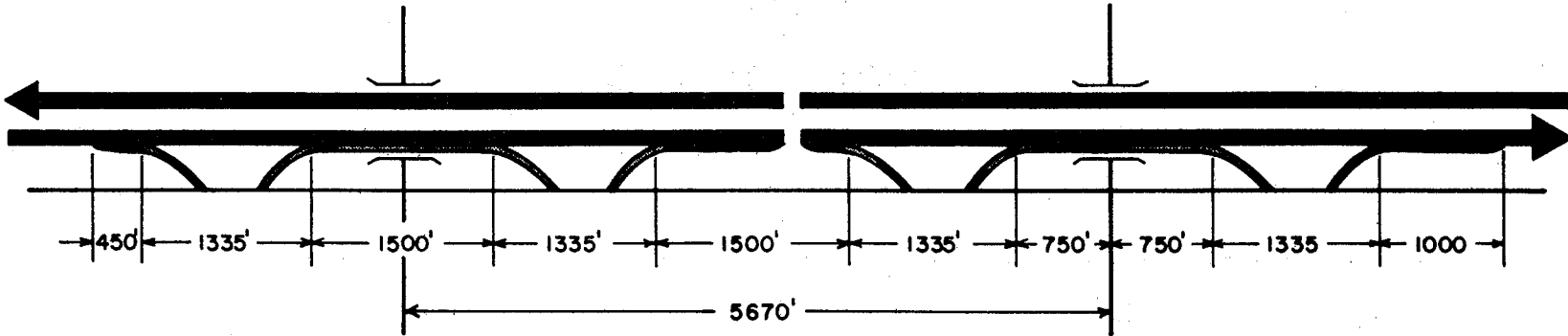

**TYPE I FREEWAY LAYOUT**  
 (MINIMUM SPACING DESIGN)

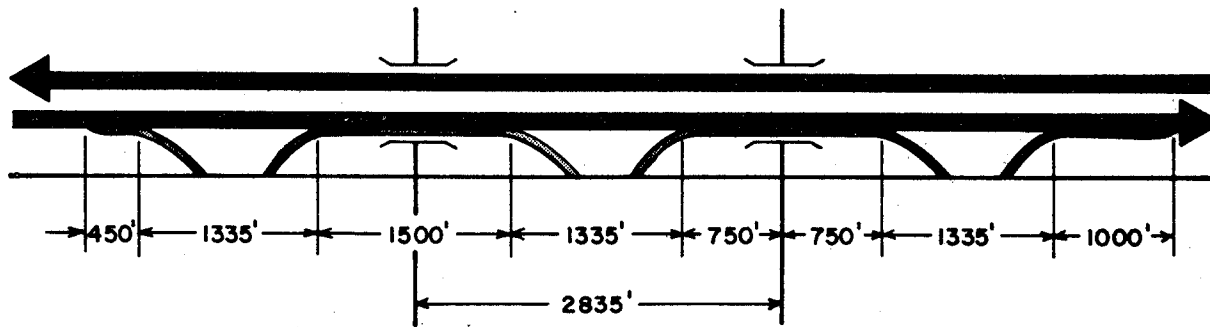

**SPECIAL CASE OF A TYPE I FREEWAY LAYOUT**  
 (MINIMUM SPACING DESIGN)

**TYPE I FREEWAY LAYOUTS**

**FIGURE 2**

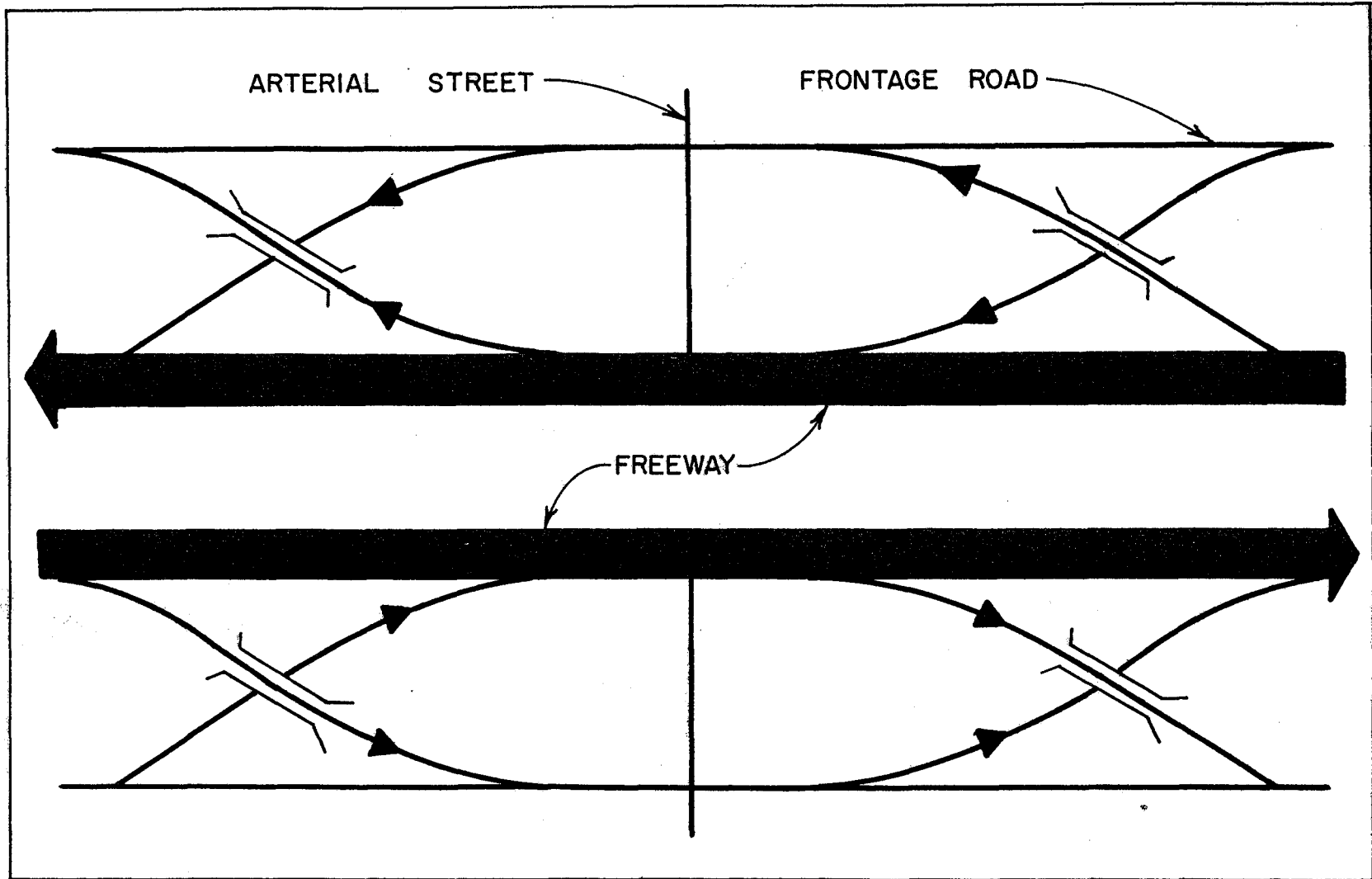

### STACKED RAMPS

FIGURE 3

THE EFFECTS OF OFF-RAMPS ON FREEWAY OPERATION AS RELATED TO  
DECELERATION DISTANCE AND OFF-RAMP CAPACITY

by

Charles Pinnell  
and  
James D. Carvell

Research Report Number 59-1

Off-Ramps on Freeway Operation  
Research Project Number 2-8-63-59

Sponsored by  
The Texas Highway Department  
In Cooperation with the  
U. S. Department of Commerce, Bureau of Public Roads

October 1965

TEXAS TRANSPORTATION INSTITUTE  
Texas A&M University  
College Station, Texas

## INTRODUCTION

### Statement of the Problem

The problem of obtaining efficient freeway operation during periods of peak flow has become extremely difficult as traffic demand has increased. This problem will grow since all indications are that traffic demand will continue to increase. If a freeway is to fulfill its purpose, i.e., to move high volumes of traffic at desired speeds and with maximum safety, all aspects of design and operations must be considered.

Little attention has been directed toward the consideration of the effect which off-ramps may have on freeway operations. The Texas Transportation Institute and the Texas Highway Department in cooperation with the Bureau of Public Roads have undertaken a research project to evaluate the effects of off-ramps on freeway operation. The specific objectives of this phase of the project work were as follows:

1. To evaluate the effect of off-ramps on freeway operation as related to deceleration distance.
2. To study the capacity of off-ramps as related to their ability to move traffic from the freeway to the service road or arterial street system.

### Previous Investigations

#### Deceleration Distance

It is generally agreed that proper off-ramp design should include the following criteria:

1. Deceleration of exiting vehicles should take place off of the freeway.
2. A natural exit path should be provided.
3. Adequate deceleration distance should be provided so that no significant speed changes will be required.

Traffic using exit ramps meeting these criteria are expected to cause little interference with freeway traffic.

The two most prevalent types of exit ramps are shown in Figure 4. These are the parallel lane type and the direct taper type. The first type



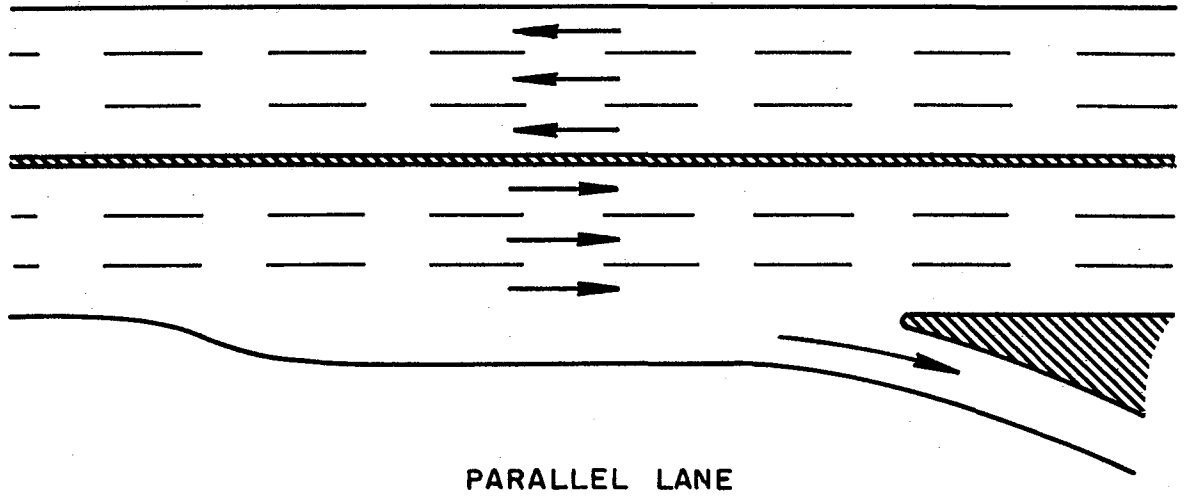

PARALLEL LANE

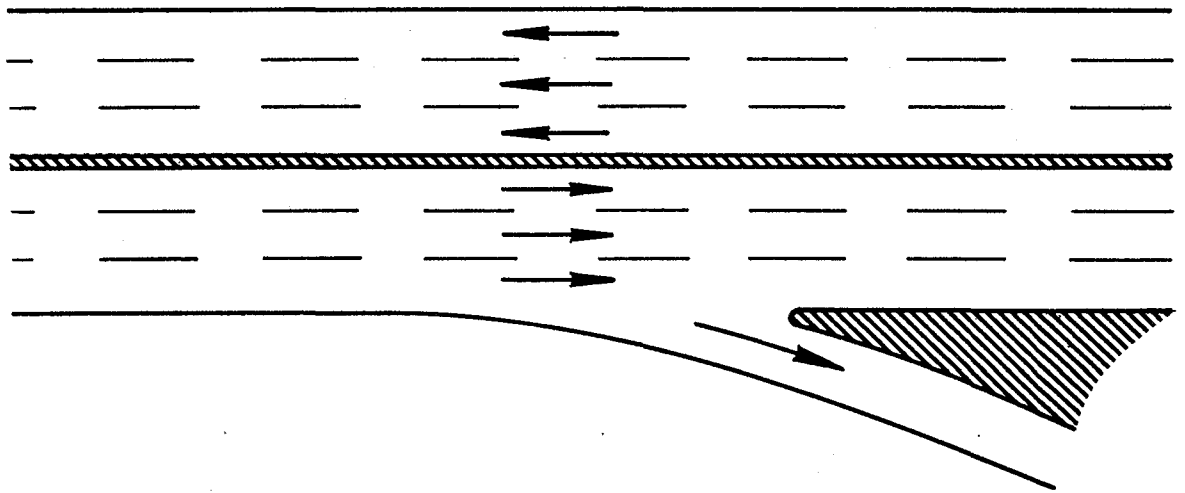

DIRECT TAPER

EXIT RAMP TYPES

FIGURE 4

allows deceleration on the parallel lane adjacent to the main freeway lanes. Studies of driver desires and behavior on off-ramps have generally shown that drivers tend to follow a natural straight path when exiting no matter which type of ramp was provided.

Jouzy and Michael found this to be true and that ninety percent of the drivers using the deceleration lane diverged within a distance of 300 feet of the ramp.<sup>1</sup> Conklin further documented the fact that the reverse curve movement required by a parallel type ramp was awkward and inconvenient to most motorists.<sup>2</sup> Fukotome and Moskowitz<sup>3</sup> noted that if a parallel deceleration lane was provided, very few drivers utilized the lane in the manner intended, that is a reverse curve movement. Drivers tended to utilize this type of exit ramp as if it were a direct taper, natural path design.

The parallel deceleration lane has a real advantage under high density conditions in that lane utility can offset undesirable geometric features such as poor sight distance, excessive curvature and others. The fact that parallel deceleration lanes are not driven as constructed may not necessarily be a bad feature.

A desirable exit ramp design was set forth by Pinnell and Keese.<sup>4</sup> This ramp design provides for a natural exit path, adequate sight distance, and delineation of the off-ramp nose and deceleration area. The suggested ramp design is shown in Figure 5.

### Ramp Terminal Capacity

Capacity of freeway off-ramps can be defined in three general areas as shown in Figure 6. These areas are as follows:

1. Capacity of the diverging movement from the freeway to the ramp.
2. Capacity of the ramp proper.
3. Capacity of the ramp terminal.

Capacity of the diverging movement from the freeway is directly dependent on the number of vehicles which desire to exit and which can get into the outside freeway lane. This will vary according to many factors, and has been studied in detail by Hess,<sup>5</sup> Lipscomb,<sup>6</sup> and by Moskowitz and Newman.<sup>7</sup> These methods generally determine the number of exiting vehicles which can be expected to be in the outside freeway lane at various points upstream of an off-ramp. The methods utilize empirically derived curves or equations for this determination.

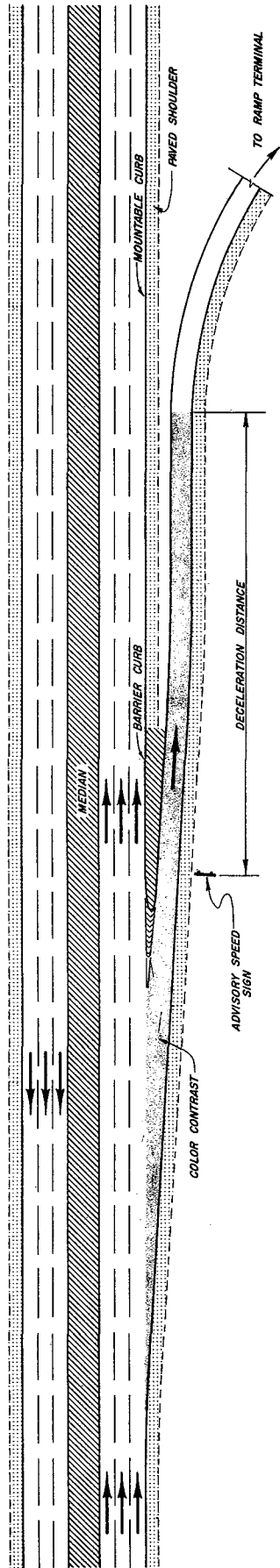

DESIRABLE EXIT  
RAMP DESIGN  
FIGURE 5

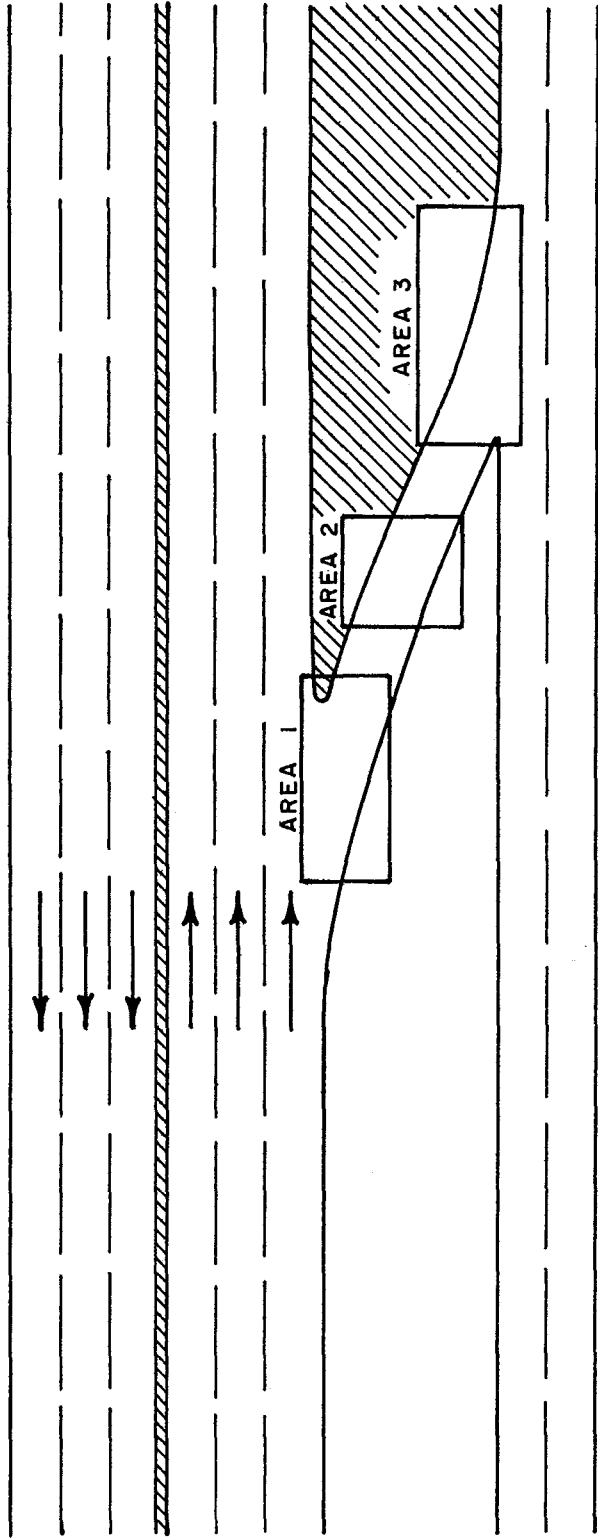

# CRITICAL CAPACITY POINTS

FIGURE 6

The capacity of the second area, the ramp proper, is essentially dependent on the same factors as normal roadway sections. The number of lanes provided, the degree of curvature, the vertical alignment, and other factors will influence the capacity of the roadway section as well as the off-ramp proper. Determination of this capacity is an essential part of the Highway Capacity Manual.<sup>8</sup>

The third area, the ramp terminal area, is essentially a merging problem. Hardly any design data have been available to the designer to aid in selecting an off-ramp which will be of sufficient length to cause no spill-back to the freeway lanes. Various researchers have evaluated merging capacity as related to entry to the freeway, but little documentation has been made of the effect inadequate merging capacity at the ramp terminal may have on the operation of the freeway. This ramp terminal capacity may be the most critical of the three capacity areas as far as freeway operation is concerned.

## DESCRIPTION OF STUDY PROCEDURES

As stated previously, the study was divided into two distinct areas. These areas and general method of study are as follows:

1. A study of deceleration distance in the vicinity of off-ramps as determined by film studies and acceleration noise analysis.
2. A study of ramp terminal capacity by simulation techniques.

### Deceleration Distance

#### Location and Characteristics of Study Sites

Film Studies - Two locations for film studies were selected on the Gulf Freeway in Houston, Texas. These off-ramps were selected as examples of off-ramp design which is inadequate by present standards. Their general locations are shown in Figure 7.

The first ramp was outbound Exit 4, or the Telephone Road Exit Ramp, shown in detail in Figure 8. This ramp is characterized by a very short taper and narrow gore area provided for deceleration. To add to the problem, there are actually two destinations on the off-ramp after leaving the freeway (see Figure 8). One destination is a normal movement to the frontage road while the other is a sharp "buttonhook" movement which requires considerable deceleration for a safe maneuver. The first destination, a normal exit movement, requires a departure from the natural vehicular path. Because of the shape of this ramp, the normal exit movement follows a reverse curve path which was referred to previously.

The second Gulf Freeway location was outbound Exit 7, or the Myrtle Exit Ramp, shown in Figure 9. As in Exit 4, an extremely short gore area exists with little provision for deceleration. Two destinations from the freeway are provided but the buttonhook is not as critical as in Exit 4 since some deceleration distance is provided on the ramp before the buttonhook movement. The normal straight through exit again requires a reverse curve movement, unnatural and inconvenient for the driver. This ramp has the added problem of being located some 200 feet downstream of a downgrade from an overpass.

The third film study location, shown in Figure 10, was the outbound Seminary Drive Exit located on I. H. 35 in Fort Worth. This off-ramp provides a smooth, natural path for vehicles leaving the freeway and has no physical features such as sharp turns or downgrade approaches that influence the traffic flow at the off-ramp.

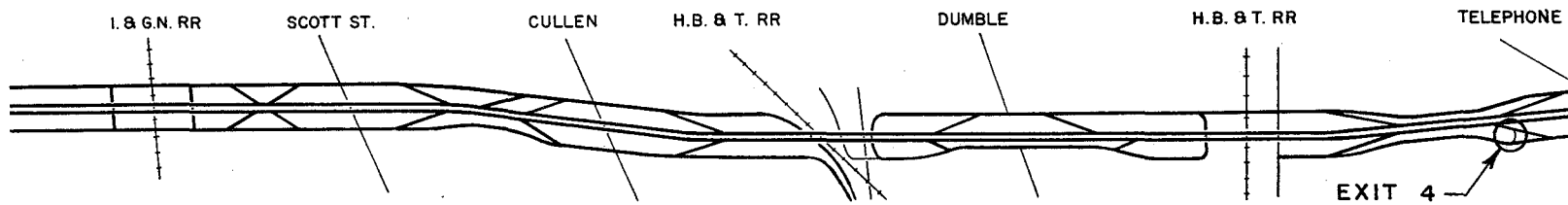
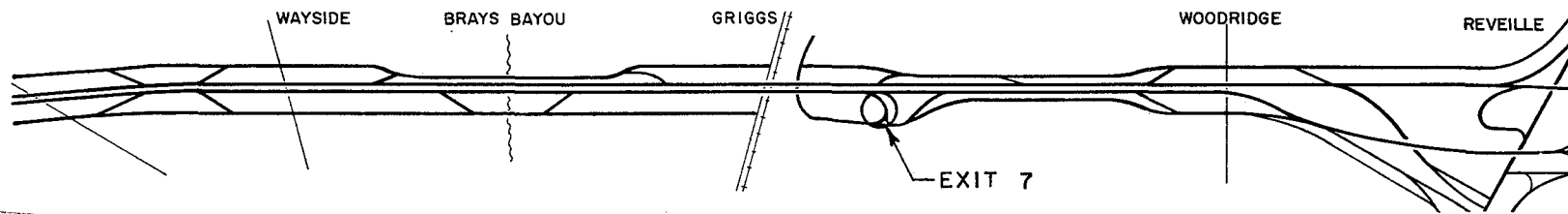

**GULF FREEWAY FILMING LOCATIONS**

FIGURE 7

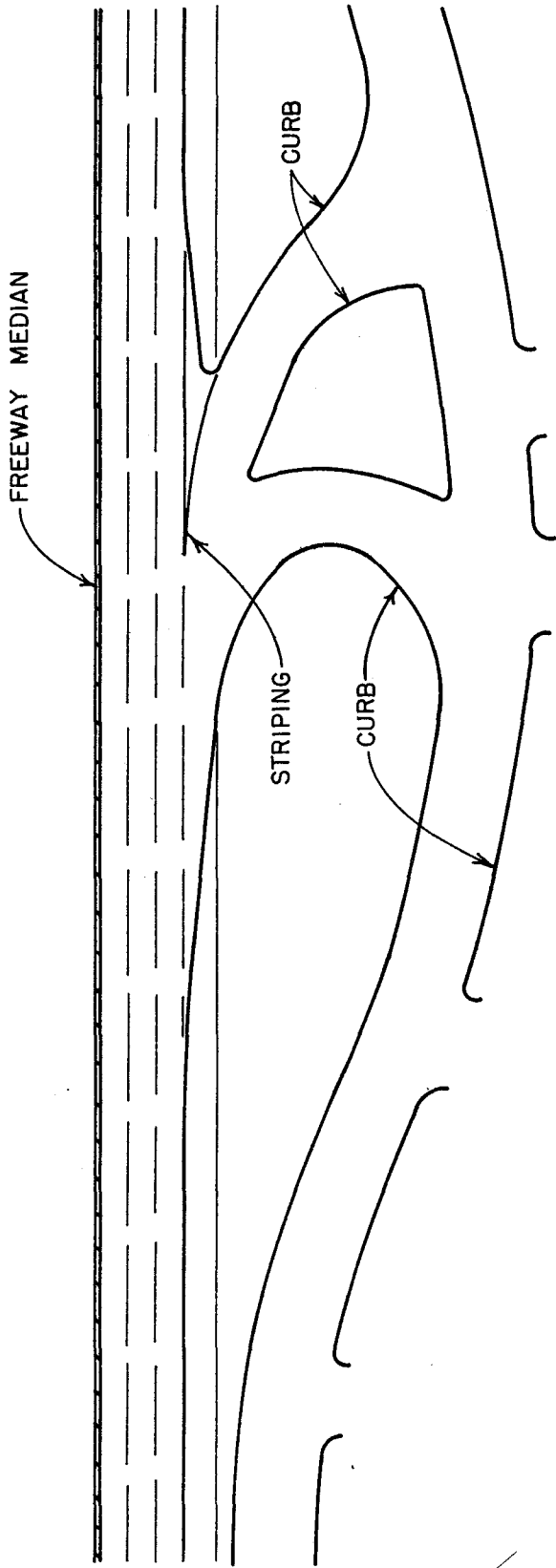

FIGURE 8 - EXIT 4 (TELEPHONE OFF-RAMP).



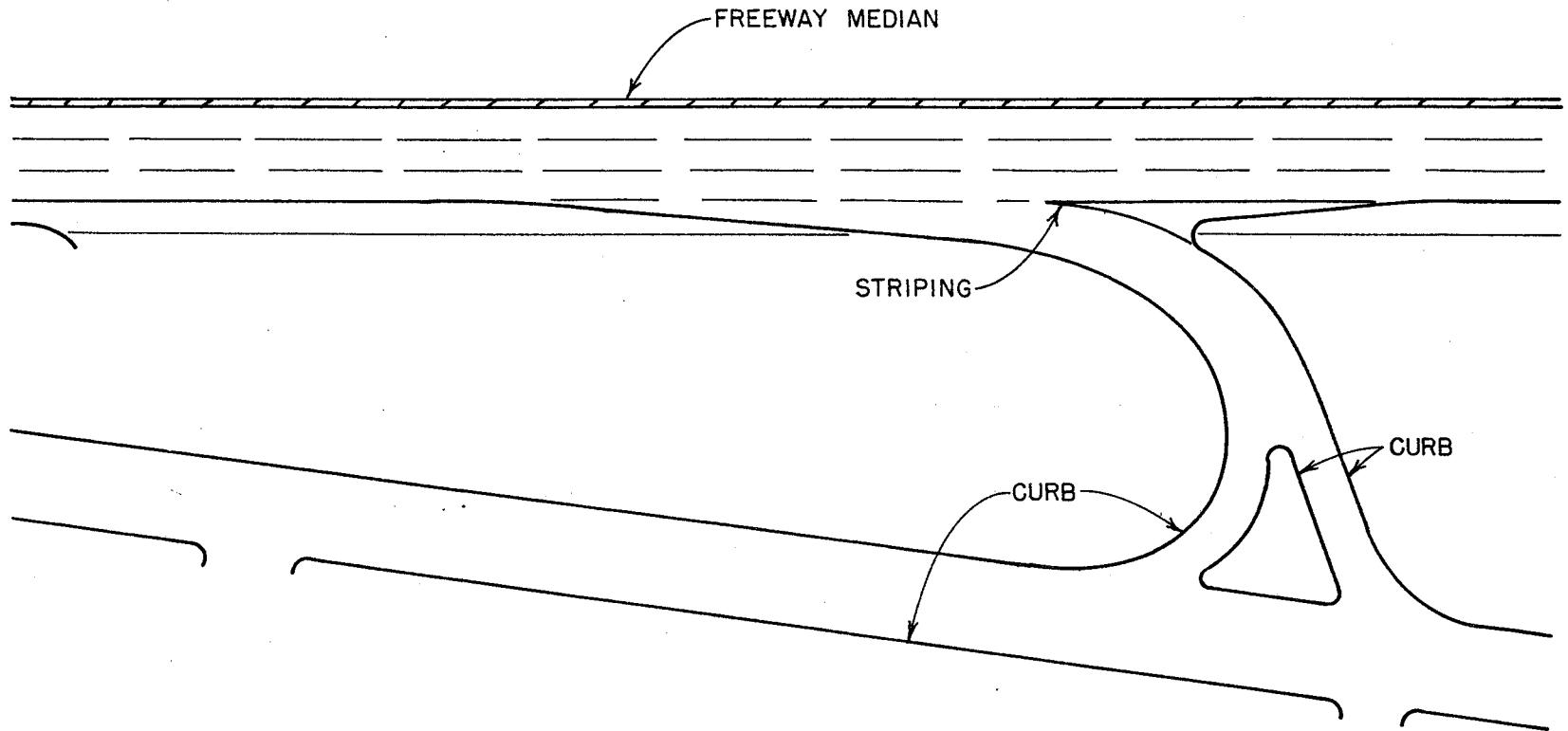

FIGURE 9 - EXIT 7 (MYRTLE OFF-RAMP).

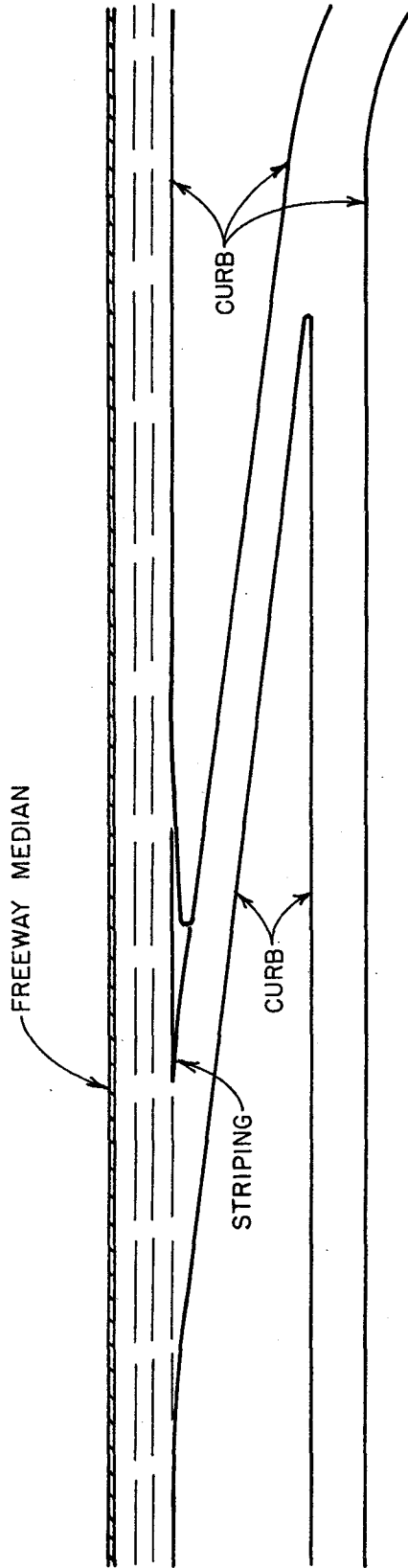

FIGURE 10 - SEMINARY OFF-RAMP.

Acceleration Noise Study - One method which has been advanced as a means of evaluating the smoothness of traffic flow is the measurement of acceleration noise. Acceleration noise is defined as the standard deviation of acceleration.<sup>10</sup> This factor reflects the change of speed of a vehicle from a smooth, uniform speed. These speed changes may be a result of any number of factors but they represent a turbidity of traffic flow and are normally undesirable as far as the driver is concerned. The acceleration noise factor was measured at locations on the Gulf Freeway shown in Figure 11.

The locations include the two Houston filming locations previously described and two additional locations. One of the additional locations is the Woodridge inbound off-ramp. This ramp, shown in Figure 12, is of a design very similar to that recommended by Keese and Pinnell.<sup>4</sup> It is characterized by a well delineated, natural exit path with adequate sight distance and no sharp, abnormal turns required.

The fourth and fifth locations are in the Bray's Bayou area, inbound and outbound. No on or off-ramp is located within 1000 feet in either direction of the 600-foot study section and it was felt that this would provide a means of comparison between acceleration noise levels as affected by ramps and unaffected by ramps.

#### Method of Study

Film Study - The filming procedure was essentially the same at all three study locations. The actual filming was accomplished from the bucket of a lift truck some 30 feet above the ground level. From this vantage point, the camera was able to record the vehicular movement on both the freeway and off-ramp. The camera was a 16 mm type equipped with a synchronous motor which allowed the movie to be taken at a constant 10 frames per second.

Reference boards were placed in the separation area between the freeway and the service road. These boards were placed a known distance apart and in pairs such that a line drawn through the axis of these boards would be perpendicular to the freeway. The forward boards were placed at the mouth of the ramp and rear boards were placed at the known distance upstream. From determining the time a vehicle was in the "trap", or space between the front and rear boards, the speed of the vehicle could be easily determined. Figure 13 shows a typical frame from each of the films.

A 16 mm motion picture projector was used in the reduction of the data. This projector was equipped with a cumulative frame counter and since the film was taken at a constant 10 frames per second, the elapsed time in seconds for any event could be determined by counting frames and dividing by 10.

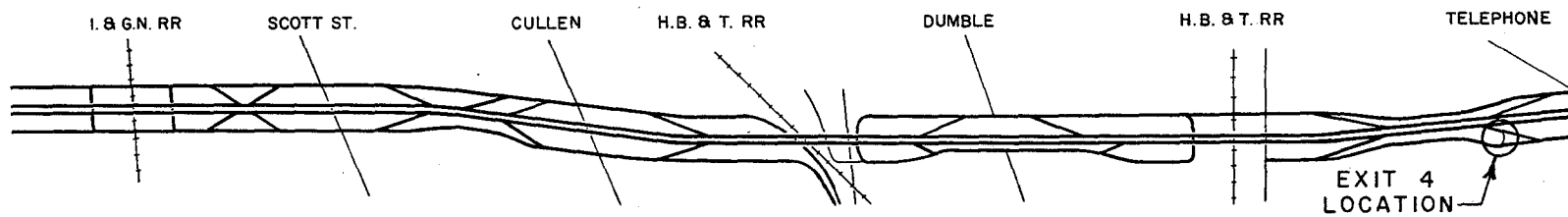
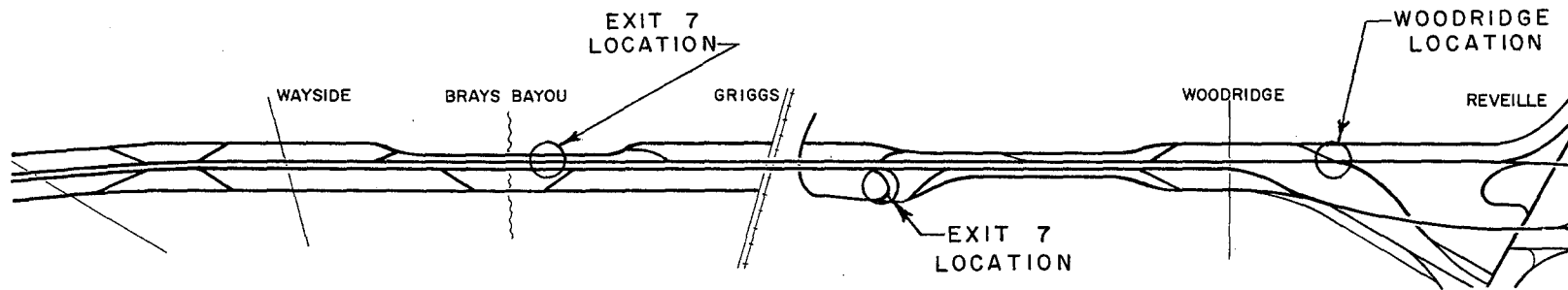

FIGURE 11 - ACCELERATION NOISE LOCATIONS.

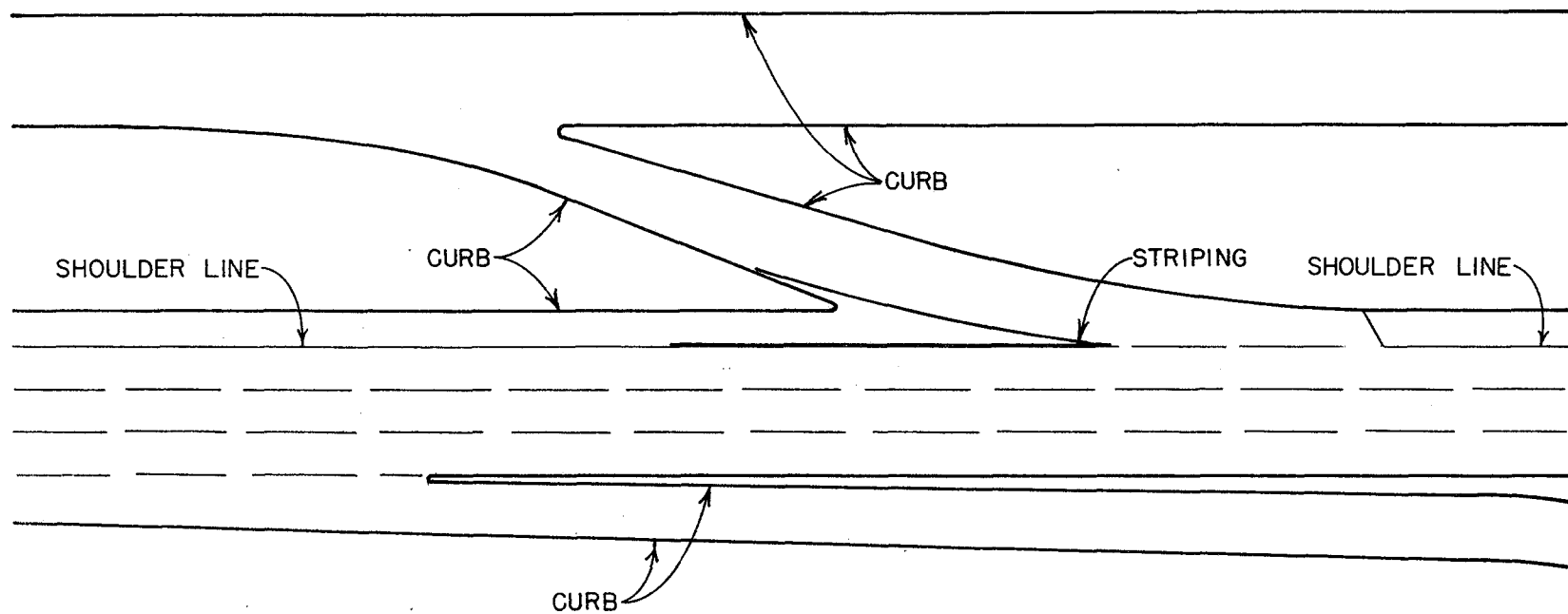
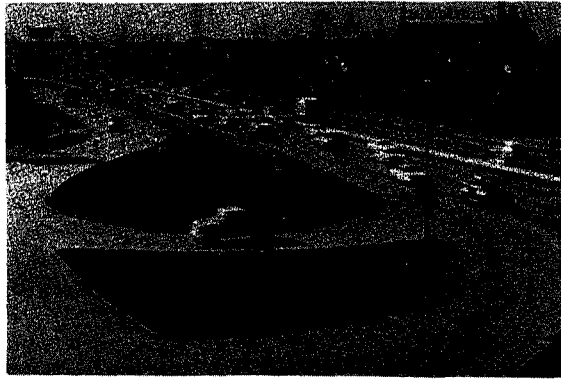
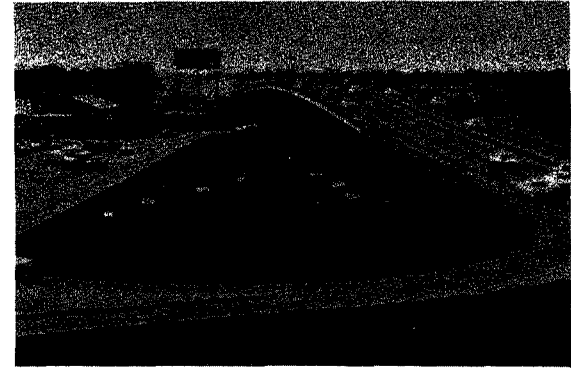

FIGURE 12 - WOODRIDGE OFF-RAMP.



TELEPHONE EXIT RAMP



MYRTLE EXIT RAMP

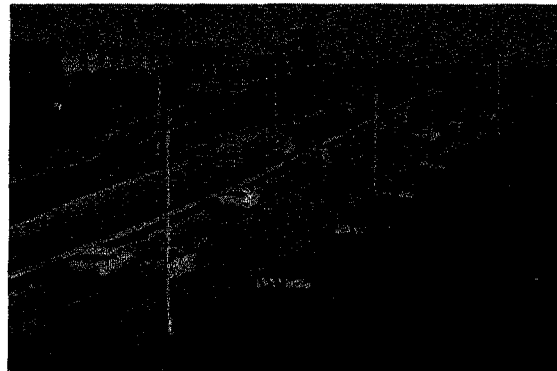

SEMINARY EXIT RAMP

FIGURE 13 - TYPICAL FRAMES FROM FILM STUDY.

By projecting the ramp area on a screen it was possible to draw a reference line across the top of each pair of the boards to define the limits of the trap. Thus by recording the frame count when a vehicle entered and left the trap, the time required by the vehicle to traverse the known distance trap was defined. The speed of the vehicle was then determined by using the time distance relationship. The actual clock time the vehicle left the trap could be determined by applying the frame count at the end of the trap to the starting time of the film.

The films of each location were analyzed in this manner. The destination (exit or through) was recorded for each vehicle on the freeway approaching the exit ramp. The vehicle number, the frame counts at the beginning and end of the speed trap and the vehicle's destination were recorded and the data placed on cards. This analysis was accomplished for each vehicle in each lane.

Acceleration Noise Study - The locations selected for study were: (1) a well-designed off-ramp (Woodridge inbound), (2) two inadequately designed off-ramps (Telephone and Myrtle outbound), and (3) a section of freeway where no ramps existed for some 600 feet in either direction (Bray's Bayou area).

A floating car technique was used in the collection of data for the acceleration noise analysis. In this technique the driver of the test car positioned himself in the outer traffic lane and "floated" with traffic so as to approximate the speed and acceleration of the average vehicle in the stream at that time and at that general location.

The vehicle was equipped with a recording speedometer to measure speeds. This device consists of a moving, graduated chart on which the vehicle's speed is continually recorded by means of a needle which is connected to the vehicle's drive shaft. A special contact switch causes the needle to swing a large arc for recording some event or reference point. This special contact was used to denote points 300 and 600 feet before the off-ramps and a point directly at the ramp opening. Figure 14 shows the speed recorder.

The graduated chart was driven at a uniform rate of 1 inch per 10 seconds so that by measuring longitudinally, elapsed time between any two events may be determined. The transverse scale was graduated in miles per hour so that speeds could be readily determined. The recorder had a capability for the adjustment of the length of the arc of the speed recording needle so that greater accuracy could be obtained. The swing of the needle was adjusted such that the full scale deflection was 75 mph and readings were graduated in 1 mph increments.

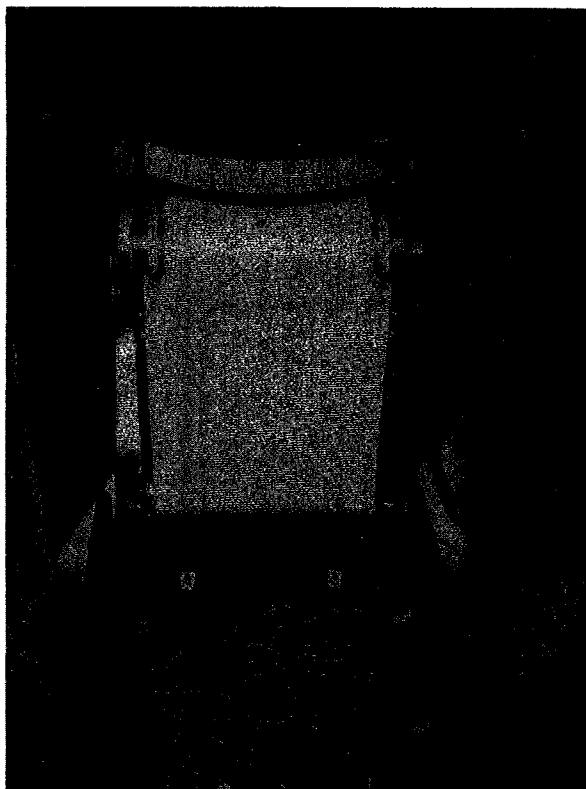

**SPEED RECORDER**

FIGURE 14



## Capacity Analysis

The problem of capacity evaluation for an off-ramp terminal becomes extremely difficult when approached in a real, physical situation. So many variables enter the problem that it becomes almost impossible to measure all values or ranges of values at any one facility. In order to evaluate the terminal capacity of an off-ramp, it would be necessary to know what effect a wide range of frontage road volumes and ramp geometrics would have on the capacity. To find field locations whose characteristics would coincide with the range of variables desired would be most difficult, if not impossible.

The use of a simulation technique on a electronic computer greatly facilitates an analysis of this type. In the simulated situation, the characteristics can be varied over a wide range of values with a fraction of the time and cost required to study a real situation. The simulation program is based on factual data and reflects results which closely approximate a real-life situation.

A program which simulates the operation of an off-ramp has been written by Woods<sup>11</sup> as a part of an entire diamond interchange simulation. This program was modified to reflect three major items: variable ramp length, adjustment of exiting speed, and the detection of queue length.

The off-ramp program uses a random number generator coupled with a Poisson distribution to simulate vehicle arrivals on the freeway, frontage road, and exit ramp. Vehicle speeds are also determined by random number generation using a certain desired speed and predetermined standard deviations of speeds. The program has a technique for checking headways of vehicles and adjusting following vehicle speeds when this headway falls below a certain "safe" headway.

There are two features which the program has for controlling the flow of exiting vehicles when they merge with frontage road traffic. First there is a stop condition where the exiting vehicle is required to come to a full stop, select a gap in the frontage road traffic, and proceed. Secondly, a yield condition can be placed on the exiting vehicle and the driver must select a gap but is not required to stop unless an acceptable gap in the frontage road traffic is not available. This condition is essentially the same as the condition where there is no control on either frontage road or exit ramp.

A third condition which is not built directly into the simulation programs is the situation where an exiting vehicle has a direct access to the frontage road and is required to neither yield nor stop. This is a situation which would exist when the frontage road vehicles are required

to stop or yield or where an extra lane is added for the exiting vehicle as it enters the frontage road. This condition can be simulated in the program by setting the frontage road volume equal to zero. The capacity of this situation should be essentially the same as the number of vehicles which can exit from the freeway.

The simulation program was run for combinations of the following conditions:

1. Ramp lengths of 200, 300, 400, and 1000 feet.
2. Frontage road volumes of 0 to 1,200 vehicles per hour in 100 vph increments in the lane adjacent to the off-ramp.
3. Off-ramp volumes of 100 to 1,200 vehicles per hour in 100 vph increments.
4. Freeway volumes of 1,400 vehicles per hour in outside lane.
5. Exit speeds of 30 and 40 miles per hour.

The problem of capacity was approached from the aspect of vehicle queue lengths. When these queues became of sufficient length that they "spilled back" onto the outside lane of the freeway, capacity was exceeded. This spill back can cause severe congestion not only in the outside freeway lane, but also in adjacent lanes due to resultant lane changing.

Freeway traffic can also be affected if the ramp queue backs to a point within a few hundred feet of the off-ramp nose. This was accounted for in the simulation program by allowing the vehicles to adjust their headways and speeds to a building ramp queue. When the speeds slowed to a certain level, a freeway breakdown occurred.

The method of study was to determine the 95 percentile queue, or that queue which is exceeded only 5% of the time. Using the 95 percentile queue length, the effective storage length may be determined. This effective storage length is the storage distance on the ramp proper, the straight line distance from the freeway to the frontage road. This does not include any storage on a parallel deceleration lane since, as previously pointed out, drivers do not utilize this lane for deceleration.

In each run of individual variables, the vehicle queue lengths were determined and arranged in a frequency table. The off-ramp simulation program was run to reflect a real time of thirty minutes for every combination of variables.

## ANALYSIS OF DECELERATION DISTANCE DATA

### Motion Picture Study

As stated previously, the data from each study location were recorded on data cards. These data, recorded by lane, included vehicle number, frame counts at beginning and end of trap, and vehicle destination. A computer program was written to facilitate data reduction and analysis. This program's output included individual vehicle speeds, the time each vehicle entered the trap, and a summary of averages for each five-minute period.



To evaluate the effects of exiting vehicles on the speeds of through vehicles, the program summarized speeds of through vehicles, classified by their position in relation to the exiting vehicles. A vehicle which passed the trap starting point within a specified time interval after an exiting vehicle was designated as an affected through vehicle. There were, therefore, three classifications of vehicles: (1) exiting, (2) affected through, and (3) nonaffected through.

The specified time interval was varied from 2 to 5 seconds following an exiting vehicle. Figure 15 shows a sketch of how the vehicle classification was determined by the time interval. Vehicle 1 is an exiting vehicle and Vehicles 2, 4 and 7 will pass Point A within the time interval specified and are designated as affected through vehicles. Vehicles 3, 5, 6 and 8 do not pass Point A within the time interval and are designated as nonaffected through vehicles. This type of analysis was made at each location and for each lane with average speeds being determined and classified according to exiting, affected through, or nonaffected through.

When the analysis was first begun, it was not readily known just what effect the time interval would have on the analysis of the data. That is, would vehicles in a two-second interval following an exiting vehicle be affected to a greater degree than those in a five-second interval? After an investigation of the summarized data, it appears that there is little difference in the effects as a result of varying the time interval. In the following discussions, therefore, the average effects of the varied time interval will be considered.

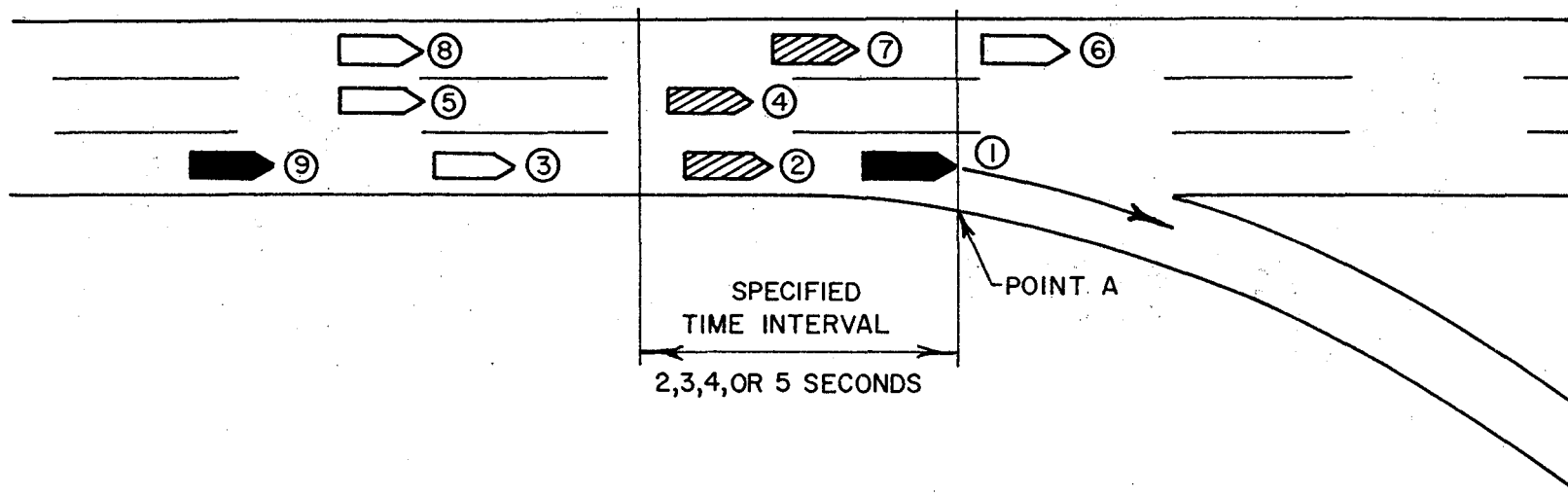
The analysis in Lanes 2 and 3 (Lane 1 being the outside lane) was identical to that described above. When a vehicle exited in lane one, vehicles within the specified time interval were classed as affected



-  EXITING VEHICLE
-  AFFECTED THROUGH VEHICLE
-  NON-AFFECTED THROUGH VEHICLE

## VEHICLE CLASSIFICATIONS

FIGURE 15

through or nonaffected through vehicles according to their position in time relative to the exiting vehicle.

A typical example of the analysis for the three lanes and a two-second time interval is shown as follows:

<u>Vehicle Number</u>	<u>Lane Number</u>	<u>Time</u>	<u>Classification</u>	<u>Speed MPH</u>
1	2	7:40:0.20	Thru	35.29
1	3	7:40:0.40	Thru	28.57
1	1	7:40:0.60	Exit	26.09
2	2	7:40:1.30	Affected	28.57
2	1	7:40:1.40	Affected	26.09
2	3	7:40:1.70	Affected	25.00
3	1	7:40:2.50	Thru	30.00
3	3	7:40:2.70	Thru	35.29
3	2	7:40:3.40	Thru	37.50

As indicated previously the data were summarized by five-minute periods. The mean speeds for vehicles in each classification were computed by lane designation.

To determine if a statistical difference existed between mean speeds of vehicles in the three categories, an analysis of variance was performed for each five-minute period. First a multiple group test was made to determine if there was a difference among the three groups. If a difference was detected, a further test, the Tukey<sup>12</sup> test, was applied to determine which groups actually differed from each other.

Analyses of variance of mean speeds were made according to the following comparisons:

1. Speeds of affected through vehicles versus the speeds of non-affected through vehicles.
  - A. Lane 1 (Shoulder lane).
  - B. Lane 2 or 3 (Inside lane).

2. Speeds of exit vehicles versus nonaffected vehicles in the outside lane.
3. Speeds of exit vehicles versus affected through vehicles in outside lane.

Results of these tests will be discussed in following paragraphs.

Since the actual filming time varied from location to location, the analysis of data was made in five-minute periods within the filming time. In addition it was felt that by considering the individual five-minute periods, variability within the filming period could be detected. By considering the entire filming period, this individual variability might not have been reflected. Subsequent presentation of data will reflect the number of five-minute periods where there was significant variation.

The detailed data for the following summaries are not included due to their length. These data are on file in the Highway Design and Traffic Engineering Department office at the Texas Transportation Institute, Texas A&M University.

#### Affected Through Versus Nonaffected Through Vehicles

The results of speed comparisons of affected through versus nonaffected through vehicles are summarized in Table 1. These mean speeds were compared at the 95% level.

Considering Lane 1 and the average effects of time intervals from two to five seconds, it can be seen that the speeds of affected and nonaffected vehicles were different in many periods. In all cases where there was a difference, the speed of the affected vehicles was less than the speed of nonaffected vehicles.

It can also be seen that speeds on the well designed off-ramp showed a significant difference in only 37% of the periods while there was a difference in speeds in 59% of the periods in the inadequately designed off-ramps.

Lane 2 shows 30% of the periods differed significantly for the inadequate off-ramp with 10% differing for the good off-ramp. There were only two lanes on the good off-ramp, but the third lane of the inadequate ramp showed virtually no difference between speeds of affected and nonaffected vehicles.

TABLE 1

95% LEVEL F-TEST COMPARISONS OF SPEEDS OF  
AFFECTED THROUGH VEHICLES VERSUS NONAFFECTED THROUGH VEHICLES

Number of Significant and Nonsignificant 5-Minute Periods

Ramp Designation		Lane 1					Lane 2					Lane 3				
		2	3	4	5	%	2	3	4	5	%	2	3	4	5	%
Inadequate Design	Number of Significant Tests	12	14	9	10	59	6	6	5	7	30	0	1	1	2	10
	Number of Nonsignificant Tests	7	5	10	9	41	14	14	15	13	70	10	9	9	8	90
Good Design	Number of Significant Tests	7	7	5	3	37	2	2	1	1	10					
	Number of Nonsignificant Tests	8	8	10	12	63	13	13	14	14	90					

The data indicated that off-ramps can have a statistically significant effect on the speeds of freeway vehicles. However, if the off-ramp is well designed, the effect of the off-ramp is minimized.

The average difference between speeds of vehicles in the various classifications is shown in Table 2. In all cases the five-minute average speeds showed nonaffected speeds traveling at the highest speed and exiting vehicles at the lowest. The reduction in speed may not appear to be drastic when examining the difference in vehicle speeds, but this apparent small speed differential may cause considerable congestion during peak traffic flow. It is a well established fact that speed changes of this order may cause shock waves to be propagated upstream adding to congestion and increasing the possibility of freeway breakdown.

#### Exit Versus Nonaffected Through Vehicles

As was pointed out in Chapter I, it is most desirable to provide off-ramp designs which result in no deceleration on the freeway proper by exiting vehicles. This situation would be virtually impossible to create for any one ramp at all times but a well designed off-ramp would closely approach this criteria.

This comparison was made in order to determine what relationship exists between the speed of exiting vehicles and the speed of nonaffected vehicles. An analysis of variance was performed on the data and the results of the F-test at the 95% level are shown in Table 3.

The well designed off-ramp showed that in 58% of the periods speeds of exiting and nonaffected vehicles were the same. This is desirable if the exiting vehicle takes on the speed of the through vehicle rather than vice versa. This means that the exiting vehicle was traveling at freeway speeds.

The results of the tests at the off-ramps of inadequate design are quite different. The statistical test showed that in 85% of the periods, speeds of exiting vehicles were significantly less than those of through, unaffected vehicles. This is highly undesirable for reasons pointed out previously. Table 2 shows the actual speed differential.

#### Exit Versus Affected Through Vehicles

This comparison was made to determine what effects, if any, exiting vehicles have on the speeds of affected vehicles as related to the speed of the exiting vehicles rather than the nonaffected vehicle. If the speeds show no significant difference and the difference between affected and



TABLE 2

AVERAGE SPEED DIFFERENTIALS BETWEEN  
VEHICLE CLASSIFICATIONS IN LANE 1

Classification \ Location	2			3			4			5		
	1-2	1-3	2-3	1-2	1-3	2-3	1-2	1-3	2-3	1-2	1-3	2-3
Exit 4 AM	4.6	2.8	1.8	4.8	2.9	2.2	3.0	3.7	3.9	5.1	2.1	3.0
Exit 4 PM	1.2	1.3	0.0	1.2	1.1	0.1	1.1	1.1	0.1	1.1	1.0	0.3
Exit 7 PM	6.2	3.2	2.9	6.2	2.7	3.5	6.2	2.2	4.0	4.6	1.5	4.1
Seminary PM	2.7	4.2	0.0	3.4	3.3	0.0	3.4	2.9	0.6	3.2	1.8	1.4

Classification 1 is a nonaffected through vehicle.  
 Classification 2 is an exiting vehicle.  
 Classification 3 is an affected through vehicle.

TABLE 3  
95% LEVEL F-TEST COMPARISONS OF SPEEDS OF  
EXITING VEHICLES VERSUS NONAFFECTED THROUGH VEHICLES

Number of Significant and Nonsignificant Five-Minute Periods

Ramp Designation		Time Interval				%
		2	3	4	5	
Inadequate Design	Number of Tests Significant	16	17	17	15	86
	Number of Tests Not Significant	3	2	2	4	14
Good Design	Number of Tests Significant	6	6	7	6	42
	Number of Tests Not Significant	9	9	8	9	58

TABLE 4  
95% LEVEL F-TEST COMPARISONS OF SPEEDS OF  
EXITING VEHICLES VERSUS AFFECTED THROUGH VEHICLES

Number of Significant and Nonsignificant Five-Minute Periods

Ramp Designation		Time Interval				%
		2	3	4	5	
Inadequate Design	Number of Tests Significant	11	12	13	13	64
	Number of Tests Not Significant	8	7	6	6	36
Good Design	Number of Tests Significant	2	0	1	0	5
	Number of Tests Not Significant	13	15	14	15	95

nonaffected is significant, then it might be hypothesized that speeds of the exiting vehicles are directly influencing speeds of affected vehicles on the freeway. Table 4 shows the results of the analysis.

The results of this analysis indicate that in 64% of the periods for the inadequate design, the speeds of exiting and affected vehicles were not significantly different. The well designed off-ramp showed that in 95% of the time periods, the speeds were the same.

In the previous section it was shown that in the case of the good off-ramp, there was a significant difference in 58% of the periods between exiting and nonaffected vehicles. With this fact in mind, the high percentage of nonsignificant periods may be interpreted to indicate that affected and exit vehicle speeds are the same 95% of the time, they both approached the speed of the nonaffected vehicle on the freeway speed.

Conversely, speeds at the inadequate off-ramp were different for exiting and nonaffected vehicles in 85% of the cases and therefore it appears that the affected vehicle's speed tends to approximate the speed of the exiting vehicle.

#### General Observations

It is virtually impossible to find two situations in which traffic and/or operational characteristics are the same. This fact presented a problem for proper evaluation of the effects of good and inadequate off-ramps. First, there were very few off-ramps of good design in the study area. Second, the traffic volumes and thus the vehicular speeds varied from location to location. Nevertheless, it is believed that these analyses are valid and logical if it is remembered that there is variability between locations.

One further observation concerning the film study of deceleration distance is set forth. It was found that during forced flow conditions, the effect of the off-ramp was negligible. Table 5 shows a comparison of tests at the Telephone Exit Ramp for the PM peak period and the AM off-peak period.

It is evident from these data and the speed differentials in Table 2 that during the peak period, speeds were fairly uniform and little difference existed for the exiting and nonexiting vehicles. This may be explained by the fact that speeds were being held at some upper limit by the concentration of traffic and there was no freedom of maneuverability. In addition, drivers were expecting and anticipating exit maneuvers and thus their speeds were not greatly influenced by exiting vehicles.

TABLE 5

95% LEVEL F-TEST COMPARISONS OF VEHICLE SPEEDS  
FOR PEAK AND OFF-PEAK PERIODS AT TELEPHONE EXIT

Time Interval		PEAK PERIOD					OFF-PEAK PERIOD				
		2	3	4	5	%	2	3	4	5	%
Affected vs. Nonaffected Vehicles	Number of Significant Periods	2	3	1	2	40	1	3	1	2	43
	Number of Nonsignificant Periods	3	2	4	3	60	3	1	3	2	57
Exit Vs. Nonaffected Vehicles	Number of Significant Periods	2	3	3	1	45	4	4	4	4	100
	Number of Nonsignificant Periods	3	2	2	3	55	0	0	0	0	0
Exit vs. Affected Vehicles	Number of Significant Periods	0	1	0	0	5	3	2	3	3	69
	Number of Nonsignificant Periods	5	4	5	5	95	1	2	1	1	31

## Acceleration Noise

Under ideal driving conditions, a driver will travel at a speed which he determines to be most suitable for his purposes. That is, he determines his own speed rather than having it determined by other vehicles or physical features of the roadway. These ideal conditions seldom exist and the driver will accelerate or decelerate according to changing traffic or roadway conditions.

The accelerations and decelerations are distributed about some mean and the standard deviation of the accelerations is the acceleration noise. Acceleration noise has been shown to indicate disturbance in the traffic stream.<sup>10</sup>

Acceleration noise was determined according to the following equation:

$$\sigma = \left[ \frac{(\Delta V)^2 \sum \frac{1}{\Delta t}}{T} \right]^{1/2} \quad (1)$$

where

$\Delta V$  is the change in speed

$\Delta t$  is the time over which  $\Delta V$  takes place

$T$  is the travel time in the selected section

Since the evaluation of acceleration noise was to be accomplished in a specific section rather than in an entire system, it was decided to use a change of 1 mph for  $\Delta V$ . This small increment provided greater accuracy than a larger one, and times were read to the nearest 0.1 second.

The acceleration noise and speeds at each of the four locations previously described were determined in a 300-foot section (Section A) and a 600-foot section (Section C) directly upstream of the off-ramp. Figure 16 shows the location of the measured sections. The running speed was determined in each section by dividing the distance by the elapsed time.

Having determined the acceleration noise in each of the two sections, it was possible to compute acceleration noise in the second upstream free-way section (Section B) by utilizing the additive property variances. This property provides for the combining or pooling of numerators and denominators of the two 300-foot sections to give the variance of the entire 600-foot section. The standard deviation is then the square root of the variance. This property is illustrated in Figure 16.

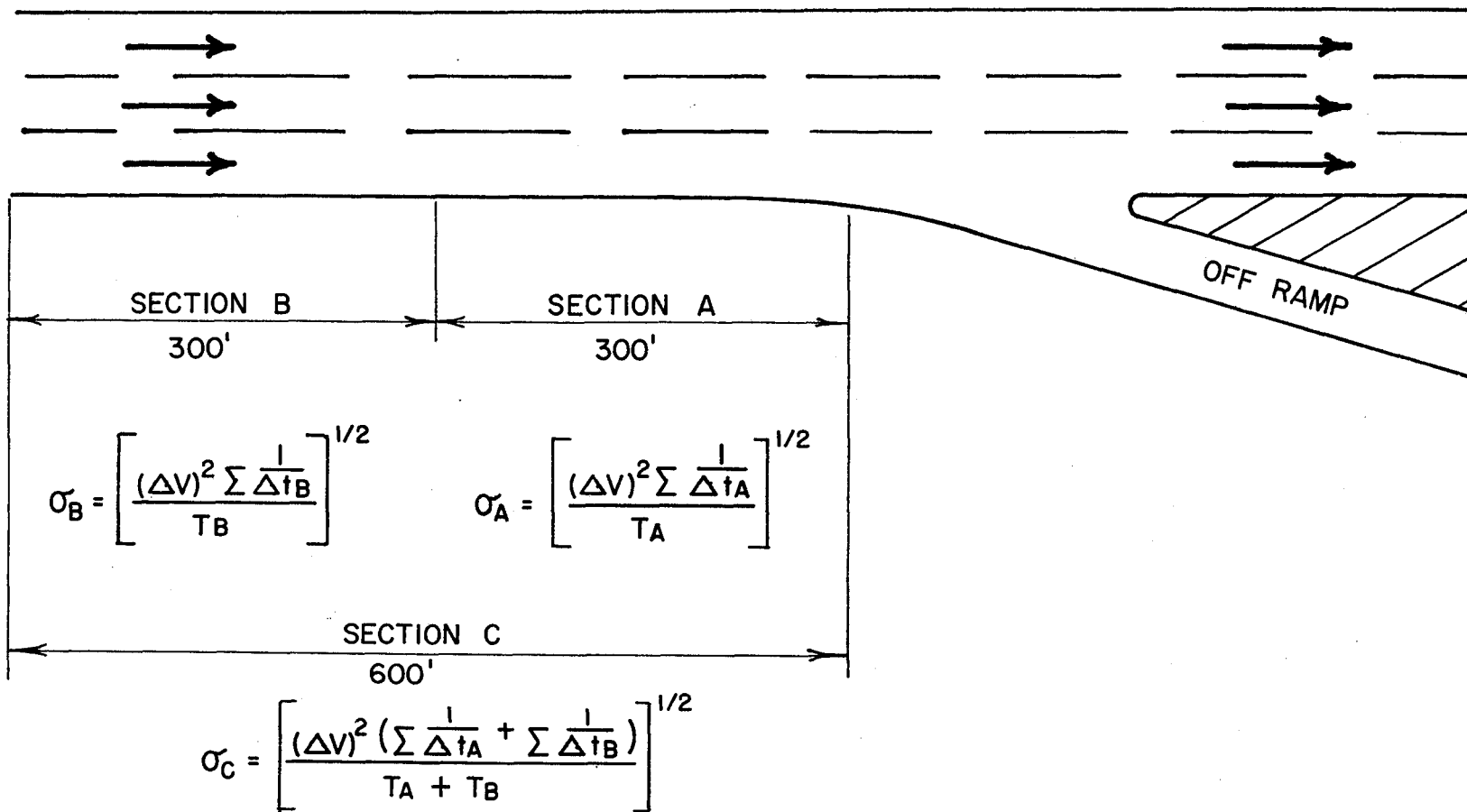

ACCELERATION NOISE MEASUREMENT POINTS

FIGURE 16

Knowing  $\sigma_C$  and  $\sigma_A$ , it was possible to compute  $\sigma_B$  according to Equation 2:

$$\sigma_B = \left[ \frac{(\Delta V)^2}{T_C - T_A} \left( \frac{\sigma_C T_C}{(\Delta V)^2} - \sum \frac{1}{\Delta t_A} \right) \right]^{1/2} \quad (2)$$

It was the purpose of this portion of the deceleration distance study to see if acceleration noise in the vicinity of off-ramps was higher than in areas located away from off-ramps. To accomplish this purpose, an attempt was made to fit the observed data to a model employed by Dudek<sup>10</sup> to describe interaction between speed and acceleration. This model, a third degree polynomial, is indicated below as Equation 3.

$$\sigma = A - B\mu^2 + C\mu^3 \quad (3)$$

where

$\sigma$  is total acceleration noise

A is maximum acceleration noise

B and C are regression coefficients

$\mu$  is the running speed

A regression analysis was performed on the observed data by means of a standard regression program written by the Texas A&M University Data Processing Center.

The results of the regression analysis indicated that there was not a high degree of correlation between the data according to the third degree polynomial. The correlation coefficients ranged from 0.164 to 0.726 for the 600-foot section. The regression curves are plotted in Figure 17 for each location and the correlation coefficients are indicated.

It can be seen that acceleration noise and thus turbidity in the traffic stream was generally higher over the range of speeds in off-ramp areas than in areas located away from off-ramps. It is further noted that the well-designed off-ramp showed less acceleration noise than those of substandard design.

It was not readily apparent what factors caused the observed data to show no significant relationship to the model. Dudek has previously shown that this model could be used to describe interaction of speed

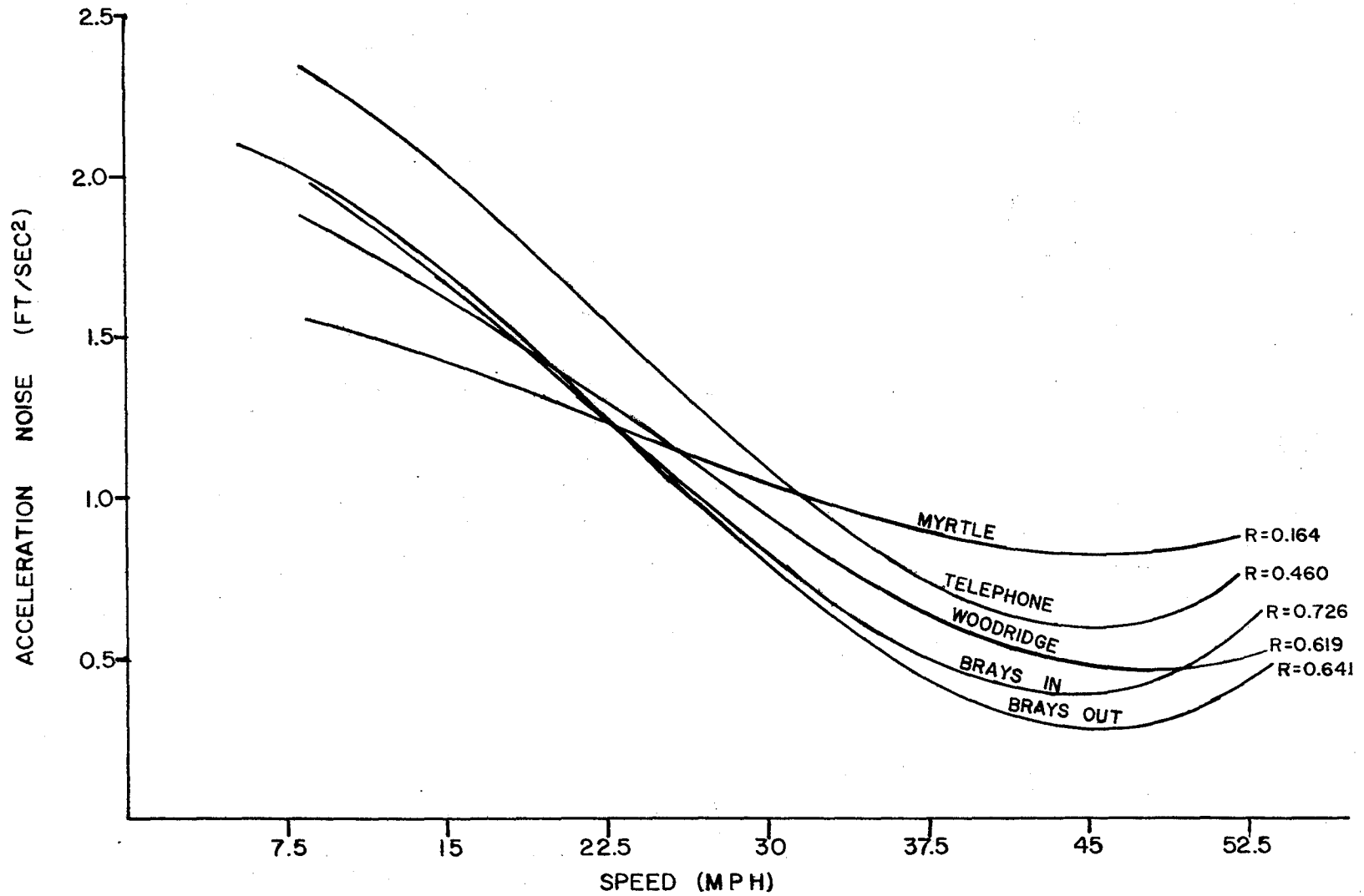

ACCELERATION NOISE REGRESSION CURVES

FIGURE 17



and acceleration noise. Possibly more data points were required over the entire range of values. Some 70 to 90 data points were collected at each location at various times of day, but possibly all traffic conditions were not reflected. It was not considered economically feasible to make additional runs in an attempt to obtain a better fit.

Although the data did not fit the proposed model, it was still possible to compare the various locations on a basis of average acceleration noise. Since every data collection run recorded values for every location, each series of points was collected under similar conditions.

The average acceleration noise was determined at each location and a multiple group test was performed to determine if there existed a difference between the locations. The Tukey Test<sup>12</sup> was again employed to determine which locations differed.

Table 6 shows the average acceleration noise at each location in each section. The results of the statistical tests indicated that all locations were significantly different at the 95% level except the Myrtle and Telephone Off-Ramps.

All three off-ramps showed a higher acceleration noise than do the locations with no ramps in the 600-foot sections. This indicates that traffic flow was smoother in the absence of off-ramps as might be expected. A further investigation of the data shows that the acceleration noise for the off-ramps of inadequate design was 20.0% and 33.8% higher for the Telephone and Myrtle off-ramps than for the Woodridge off-ramp which had superior design features.

Examination of the data for the two 300-foot sections indicates that acceleration noise decreased significantly at the 95% level for each location as the vehicle approached the off-ramp. It was first believed that acceleration noise would increase as the vehicle approached the off-ramp as an indication that the off-ramp caused higher turbidity of flow. However, this apparent contradiction might be explained by the fact that the braking by the driver possibly takes place in the 300-foot section designated as Section B and when the driver reaches the second 300-foot section, he has released the brake and is continuing at a more uniform rate. Nevertheless, the fact that there is a change in the acceleration noise indicates that the off-ramp is causing a turbidity in the traffic. In addition results may be somewhat erratic in a section of only 300 feet, the short distance being more susceptible to measurement errors.

These results indicate that off-ramps have a definite effect on freeway operation based on smoothness of flow as reflected by acceleration noise. In addition, the design of the off-ramp appears to affect the smoothness of flow.

TABLE 6

AVERAGE ACCELERATION NOISE

Location Section	Telephone Exit	Myrtle Exit	Brays In	Brays Out	Woodridge
600-Foot (Section C)	0.763	0.851	0.485	0.299	0.636
300-Foot (Section A)	0.488	0.740			0.499
300-Foot (Section B)	0.829	0.932			0.698

## ANALYSIS OF OFF-RAMP TERMINAL CAPACITY

As previously mentioned, off-ramp terminal capacity was analyzed by simulation techniques on a digital computer. The simulation program was capable of varying traffic conditions over a wide range of values for three ramp control conditions: stop, yield, or free-flow.

The figures of merit for each condition were ramp queue length, ramp volume, and frontage road volume. For the analysis, a family of curves was plotted, one for each ramp volume. These curves show frontage road adjacent lane volume versus the 95 percentile queue, or that queue which is exceeded only 5% of the time. These curves are shown in Figure 18 through 20.

These curves may be utilized in two ways. First they may be used to determine what ramp length must be provided for a certain ramp volume and frontage road volume for either stop, yield or free flow control.

Since queue length can be a measure of distance, the ramp length is actually determined by multiplying the queue length by the vehicle length. This vehicle length plus minimum headway was assumed to be 22 feet. A scale is provided on the curves for both queue length and ramp length necessary to avoid "spill-back" to the freeway lanes. An example of this usage is outlined below.

Given: Ramp volume = 400 vph

Frontage Road Volume = 400 vph

Ramp Control = Stop

From Figure 18, a ramp length of 120 feet should be provided. If the control were for the ramp vehicle to yield, Figure 19 shows a ramp of 88 feet would be required.

The second way that these curves may be used is in determination of ramp capacity. If the ramp were already constructed, and the frontage road volume known, the ramp capacity could be readily determined. An example of this method is as follows:

Given: Ramp length = 200 feet

Frontage road volume = 300 vph

Ramp capacity for a stop condition is 600 vph from Figure 18. For yield control, the capacity is 650 vph.

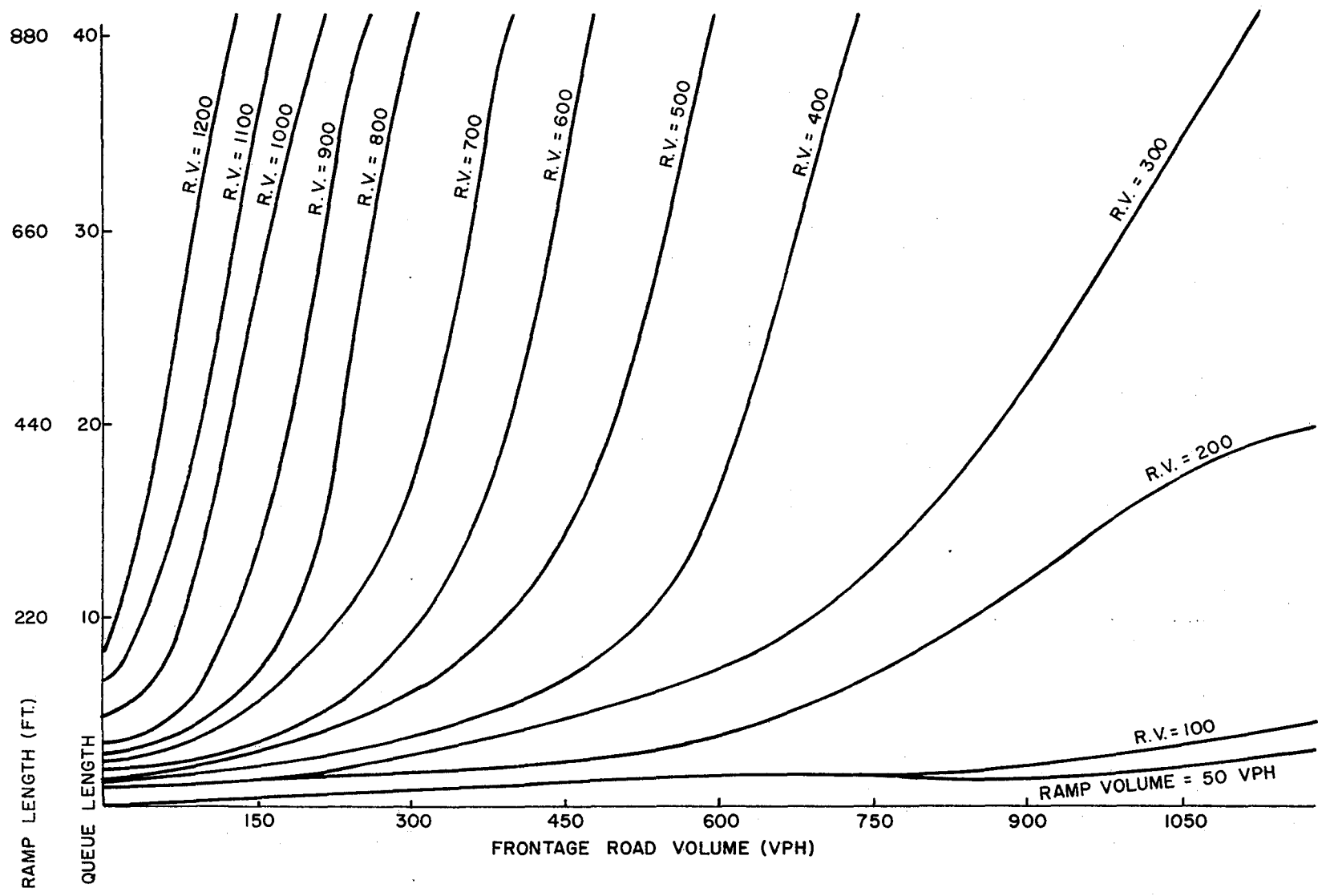

FIGURE 18 - CAPACITY FOR STOP CONTROL.

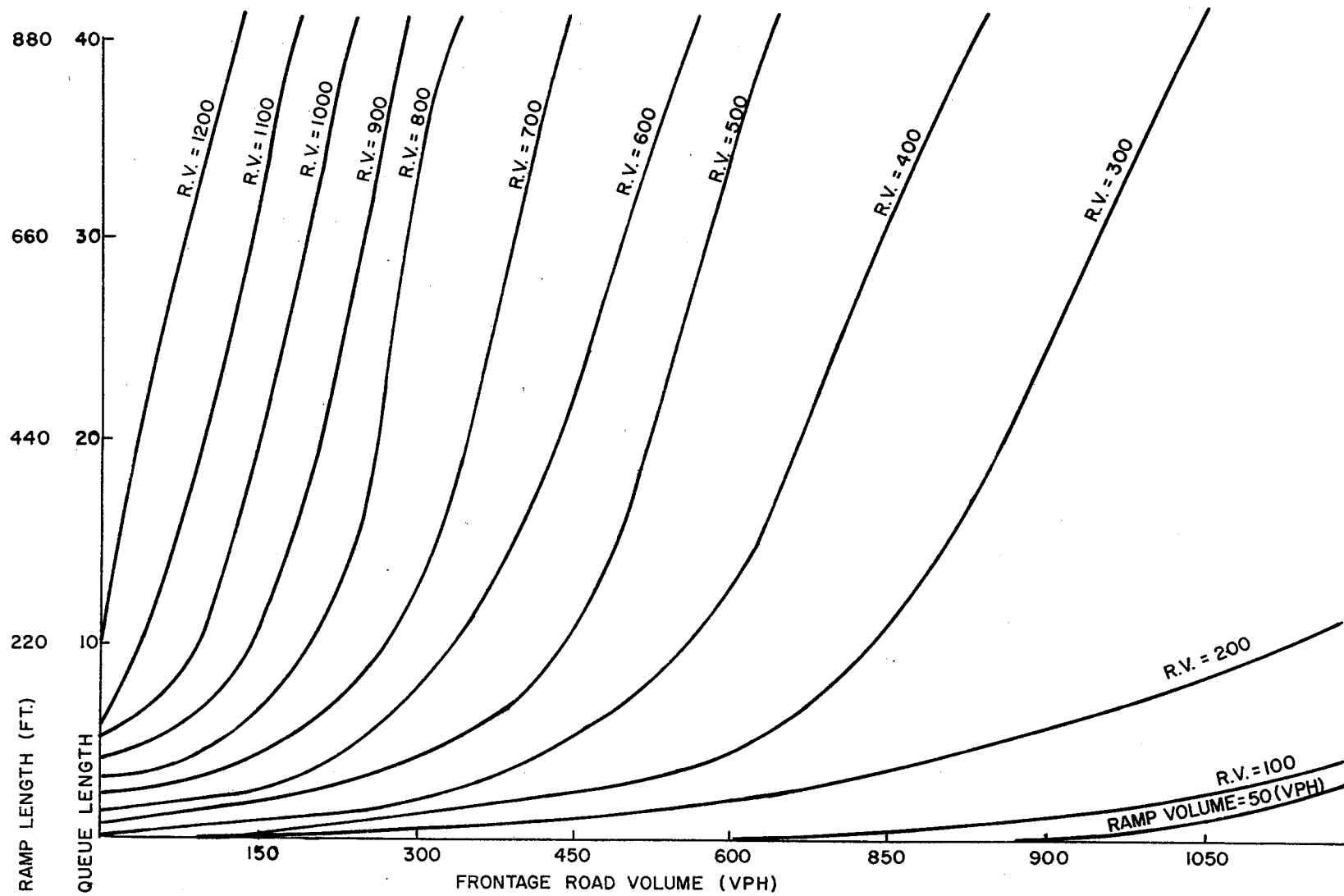

FIGURE 19 - CAPACITY FOR YIELD CONTROL.

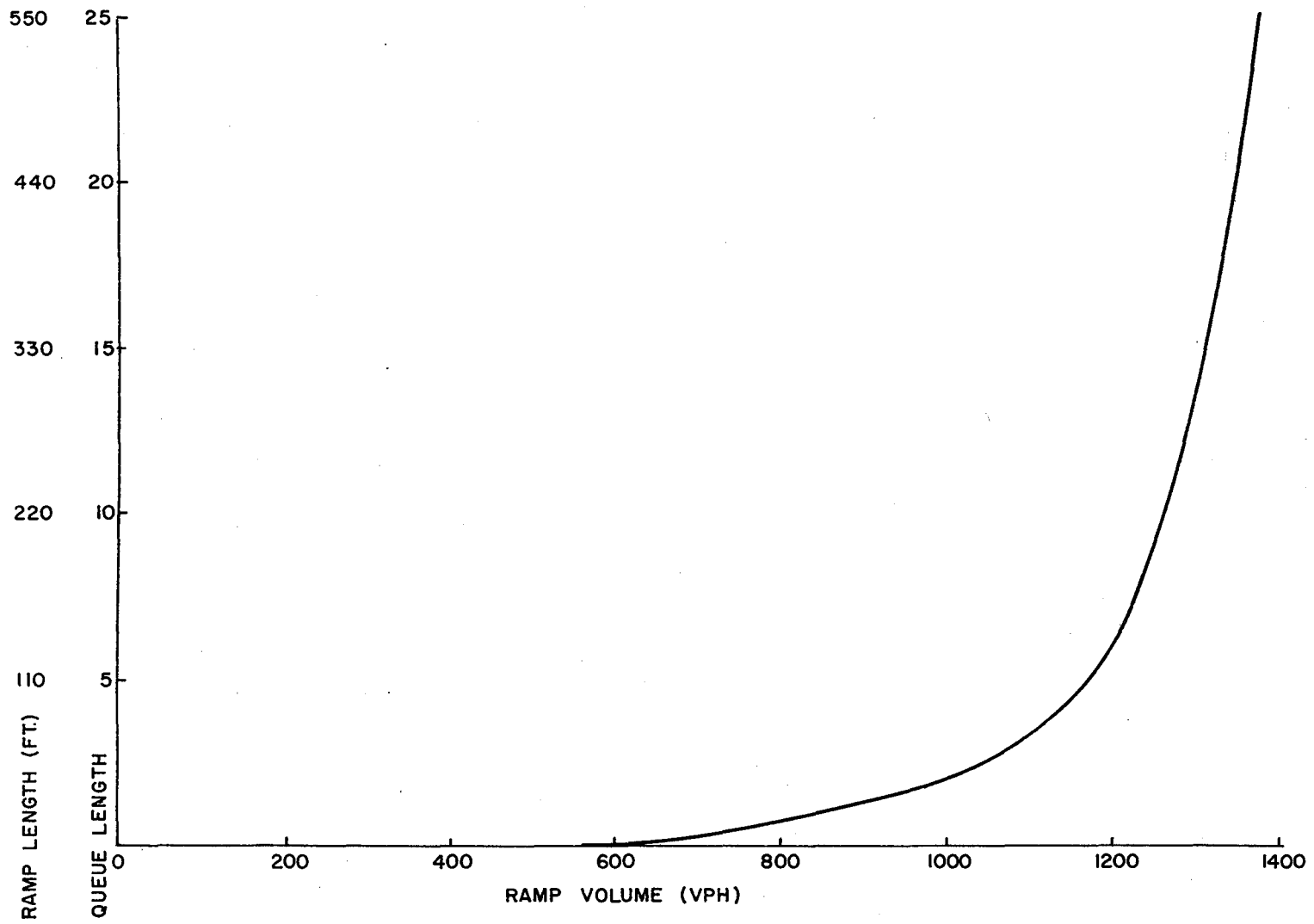

FIGURE 20 - FREE FLOW RAMP TERMINAL CAPACITY.

It can be seen that the values for stop control and yield control on the ramp are approximately equal. However, if the control is free flow with ramp vehicles having an added lane or stop control on the frontage road, a much shorter ramp length is dictated. The queue that is present in this condition results from slowing down of vehicles to maintain safe headway and is not so critical as if the driver were required to stop or select a gap.

Figure 20 shows that for the values indicated in the first example, a free flow condition would require a ramp of minimum length. In the second example, ramp capacity is 1200 vph, a considerable increase over the capacity for the other two conditions.

An analysis was performed with identical conditions except that desired speeds for exiting vehicles were 40 mph rather than 30 mph. Results of this analysis were very similar to those for the 30 mph analysis. It appears that the ramp volume is the controlling factor for queue length and exiting speed has little influence on this length. This is probably due to the fact that vehicles must adjust to some minimum headway no matter what the exiting speed.

## CONCLUSIONS

The following conclusions were drawn from this research:

1. Off-ramps have a definite effect on freeway operations. In 45% of all periods tested, the speeds of vehicles following exiting vehicles were lower than the speeds of vehicles not following exiting vehicles. Although the speeds were statistically different, the average speed differential was 2.3 mph between affected through and nonaffected through vehicles.
2. The design of an off-ramp influences the effect of the off-ramps on freeway operation. A well designed off-ramp shows less effect than one of inadequate design.
3. Off-ramps have a less pronounced effect on inside lanes than on the shoulder lane. In only 21% of all periods tested in Lane 2 speeds of vehicles affected by exiting vehicles were less than those of vehicles not affected by exiting vehicles. In Lane 3 (the median lane), only 10% of the speeds of affected vehicles were less than the speeds of nonaffected vehicles.
4. The smoothness of traffic flow as measured by acceleration noise is affected by off-ramps. However, well designed off-ramps caused less disturbance to the smoothness of traffic flow than did the ramps of inadequate design.
5. Capacity of an off-ramp terminal can be evaluated by considering the effect of the ramp queue on freeway operation. Design curves are provided for determination of off-ramp capacity and for determination of effective ramp storage length.



## BIBLIOGRAPHY

1. Jouzy, N. C. and H. L. Michael. "Use and Design of Acceleration and Deceleration Lanes in Indiana," Highway Research Record 9, 1963, pp. 25-31.
2. Conklin, R. D. "A Comparison of Vehicle Operating Characteristics Between Parallel Lane and Direct Taper Types of Freeway Off-Ramps," Proceedings, Institute of Traffic Engineers, 1959, pp. 19-29.
3. Fukotome, I., and K. Moskowitz. "Traffic Behavior and Off-Ramp Design," Highway Research Record 21, 1963, pp. 17-31.
4. Pinnell, C. and C. J. Keese. "Freeway Ramps," T. T. I. Research Report RP-17, 1960.
5. Hess, J. W. "Capacities and Characteristics of Ramp-Freeway Connections," Highway Research Record 27, 1963, pp. 69.
6. Lipscomb, J. N. "The Effects of Ramps on the Lateral Distribution on a Six Lane Freeway," Thesis, Texas A&M University, 1962.
7. Moskowitz, K., and L. Newman. "Notes on Freeway Capacity," Highway Research Record 27, 1963, pp. 44-68.
8. U. S. Bureau of Public Roads. "Highway Capacity Manual," U. S. Government Printing Office, Washington, D. C. (1950).
9. Glickstein, A., L. D. Findley, and S. L. Levy. "Application of Computer Simulation Techniques to Interchange Design Problems," Highway Research Bulletin 231, 1961, pp. 139-162.
10. Dudek, C. L. "A Study of Acceleration Noise as a Measurement of the Quality of Freeway Operation," Thesis, Texas A&M University, 1965.
11. Woods, D. L., "A Study of Traffic Characteristics of Diamond Interchanges Utilizing Digital Simulation Techniques," unpublished dissertation, Texas A&M University, 1965.
12. Bowker, Albert H., and Gerald J. Lieberman. Engineering Statistics, Prentice Hall, Inc., Englewood Cliffs, N. J., 1959.



THE EFFECTS OF OFF-RAMPS ON FREEWAY OPERATION AS RELATED TO  
SHORT TRIP GENERATION, WEAVING MANEUVERS, AND ACCESS CONTROL

by

Charles Pinnell  
and  
William E. Tipton

Research Report Number 59-2

Off-Ramps on Freeway Operation  
Research Project Number 2-8-63-59

Sponsored by  
The Texas Highway Department  
In Cooperation with the  
U. S. Department of Commerce, Bureau of Public Roads

October 1965

TEXAS TRANSPORTATION INSTITUTE  
Texas A&M University  
College Station, Texas



## SHORT TRIP GENERATION

The generation of short trips on a freeway tends to destroy the integrity of the freeway as a long trip facility. The presence of short trips during peak periods of travel can become a critical factor in freeway operations. Since drivers take paths of least resistance, frequent exit ramps may make the use of the freeway attractive for short trips. Studies of the origin and destination of ramp traffic (inbound and outbound) on the Gulf Freeway in Houston, the North Central Expressway in Dallas and Interstate Highway 20 in Fort Worth provided data from which this effect was studied.

### Gulf Freeway Studies

Inbound studies: The ramp O-D studies on the Gulf Freeway were conducted at all of the inbound entrance ramps during the a.m. peak (7:00-8:30). Drivers were stopped on the ramps and handed a questionnaire which they were requested to fill out and return. The questionnaire provided information on the origin of trip, destination of the trip and exit ramp usage. (See Research Report Number 24-7) <sup>1</sup>

As a starting point for the investigation of short trips, a study was made of the traffic entering each inbound entrance ramp and the amount of this traffic that exited from the freeway within 6000 feet. The distance of 6000 feet was picked arbitrarily as the definition of a short trip.

Figure 21 and 22 indicate the results of these studies. The total number of cars entering and the per cent exiting within 6000 feet are shown. Entrance ramps and their short trips may be followed in order from the Reveille Interchange inbound by reading from the bottom upward on each figure.

The data illustrated in Figures 21 and 22 indicate only two cases where a significant amount of short trip traffic was generated. The first case was the Mossrose entrance ramp and Wayside exit ramp with 22.5% of the traffic exiting within approximately 2000 feet of its entrance. At this location there was a discontinuous frontage road. The second case was the Telephone entrance ramp and the Calhoun-Lombardy exit ramps with 13.4% exiting within 4000 feet. At this location the frontage road crossed several railroad tracks with a very rough pavement surface. Trains often block the frontage road which makes its use undesirable from the drivers' point of view. There are also two signalized intersections to be passed through. The next two highest cases indicate 8% exiting within 6000 feet.

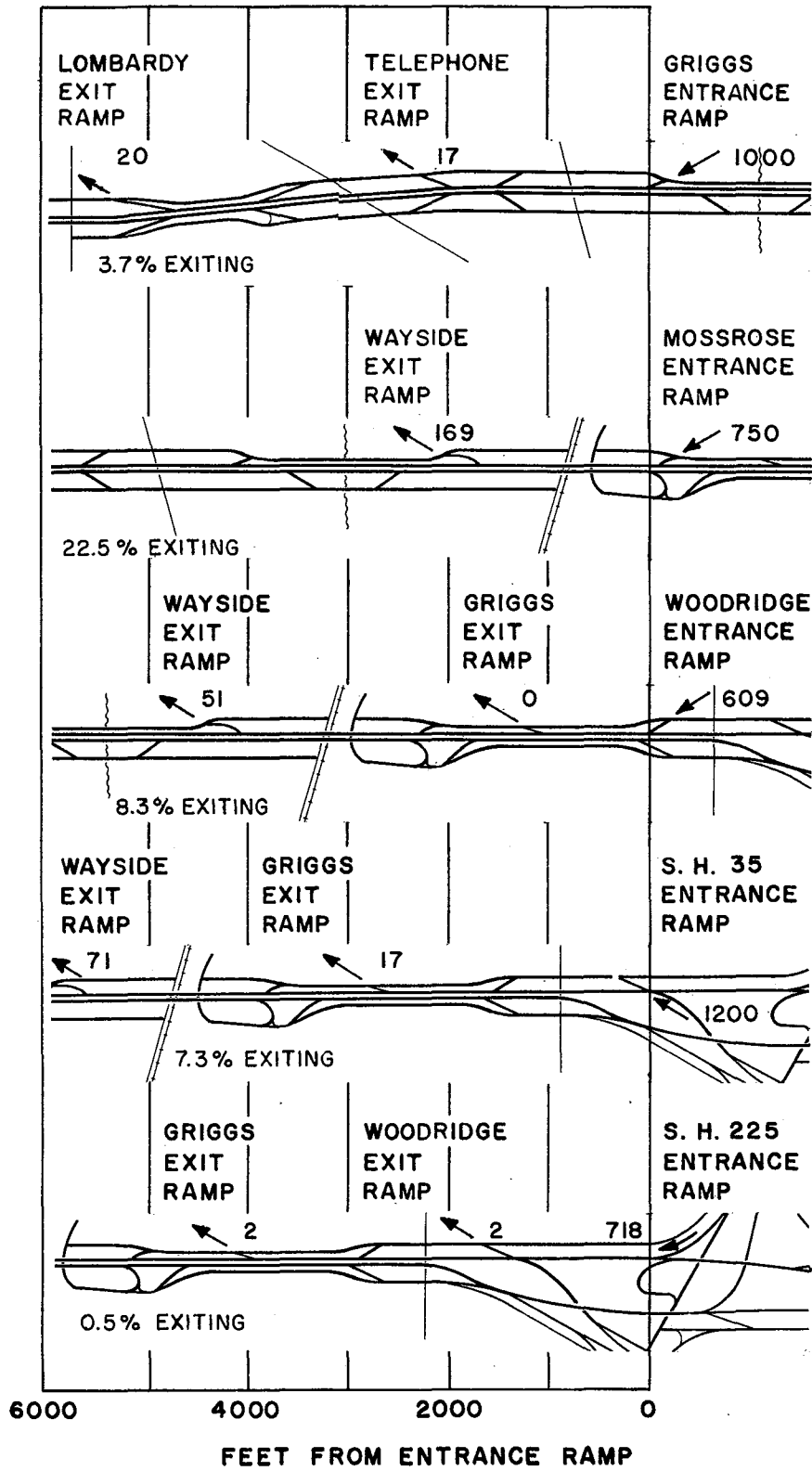

EXTENT OF SHORT TRIPS 6:45 - 8:30 AM  
 GULF FREEWAY - HOUSTON, TEXAS

FIGURE 21

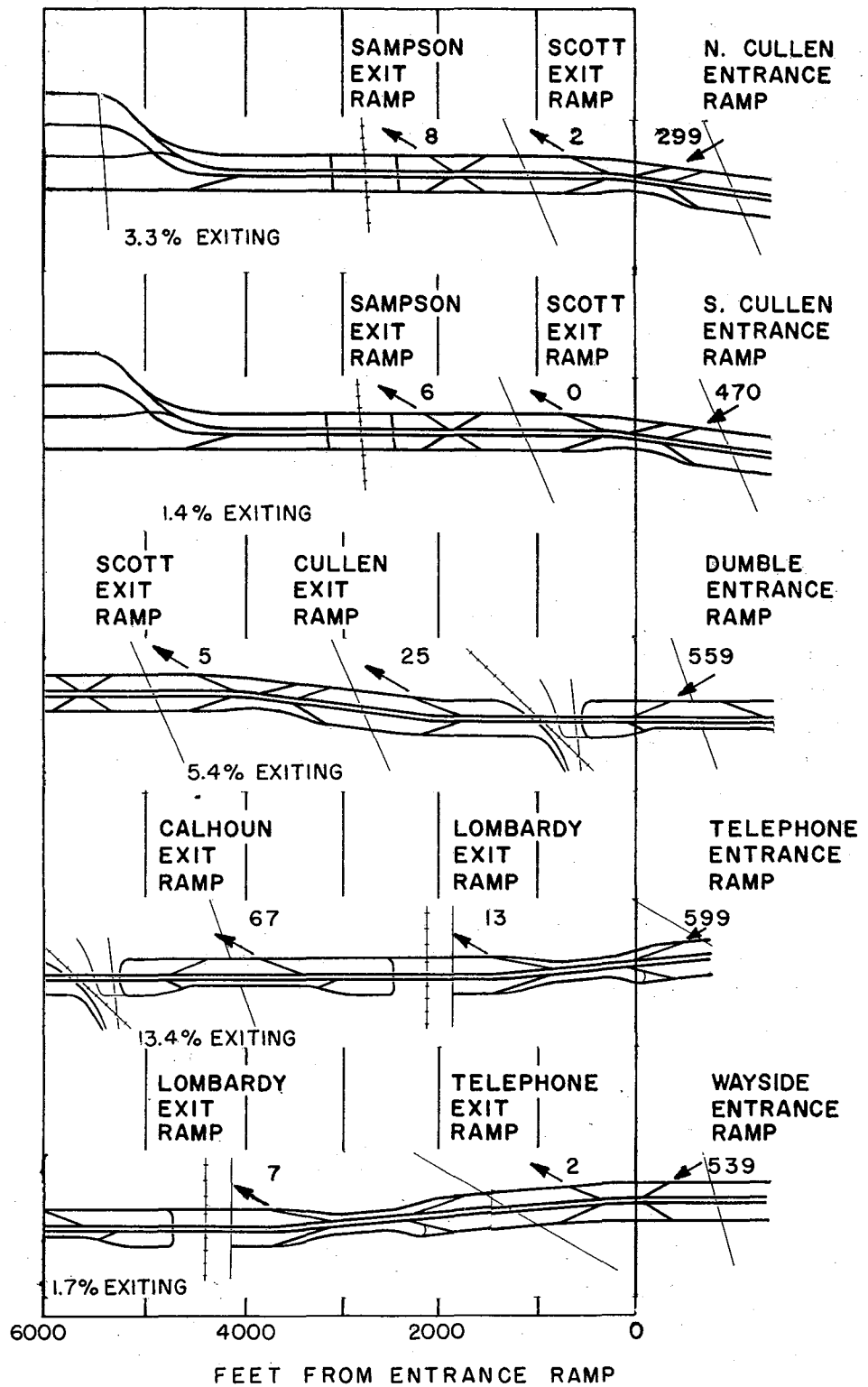

EXTENT OF SHORT TRIPS 6:45 - 8:30 AM  
 GULF FREEWAY - HOUSTON, TEXAS

FIGURE 22

Outbound Studies: The ramp O-D studies were conducted at the outbound entrance ramps during the p.m. peak (4:00-6:00). Figures 23 and 24 show the short trips which were determined from the O-D data. The entrance ramps and their respective short trips may be followed from the beginning of the Gulf Freeway in the outbound direction by reading the figure from top to bottom.

The analysis of the data illustrated in Figures 23 and 24 shows one case in which an amount greater than 10% of the entering traffic exited within 6000 feet. This occurred at the Dumble entrance ramp and the Telephone and Wayside exit ramps. The frontage road is discontinuous at this location. Even though the per cent exiting was only 5.6%, sixty-four vehicles made short trips by entering at the Wayside entrance ramp and exiting at the Winkler and Woodridge exit ramps. Once again the frontage road is discontinuous at the short trip location.

#### North Central Expressway Study

This study is referred to as the "lights-on" study since the study technique utilized involved asking each driver at a selected ramp to turn on his lights as he entered the freeway and to keep them on until after he exited from the freeway. Observers stationed at downstream overpasses and exit ramps then recorded the movement of vehicles with their lights on. The study included only one entrance ramp which was the Mockingbird on-ramp. A sketch of the study is shown in Figure 25. The frontage road can be negotiated as shown in the sketch.

Figure 26 illustrates the total amount of traffic entering the Mockingbird entrance ramp (839 vehicles) during the period 7:00-8:30 a.m. and the number of these vehicles which exit within 6000 feet. It is noted that again a very insignificant percentage (2.3%) exists within 6000 feet. It should also be noted that a continuous frontage road system exists in this area.

#### Fort Worth Interstate Highway 20 Study

The data for this study was collected by the license plate technique using one man at the Camp Bowie entrance ramp inbound and another man at the Pentecost exit ramp. Each man recorded the license numbers of the vehicles utilizing his ramp. The license plate numbers were placed on punch cards and matched using a card sorter.

This study location was suspected of having a high percentage of short trips due to a difficult intersection where the frontage road begins. This intersection was complicated by the frontage road being two-way at this point. A relatively large volume was expected to use



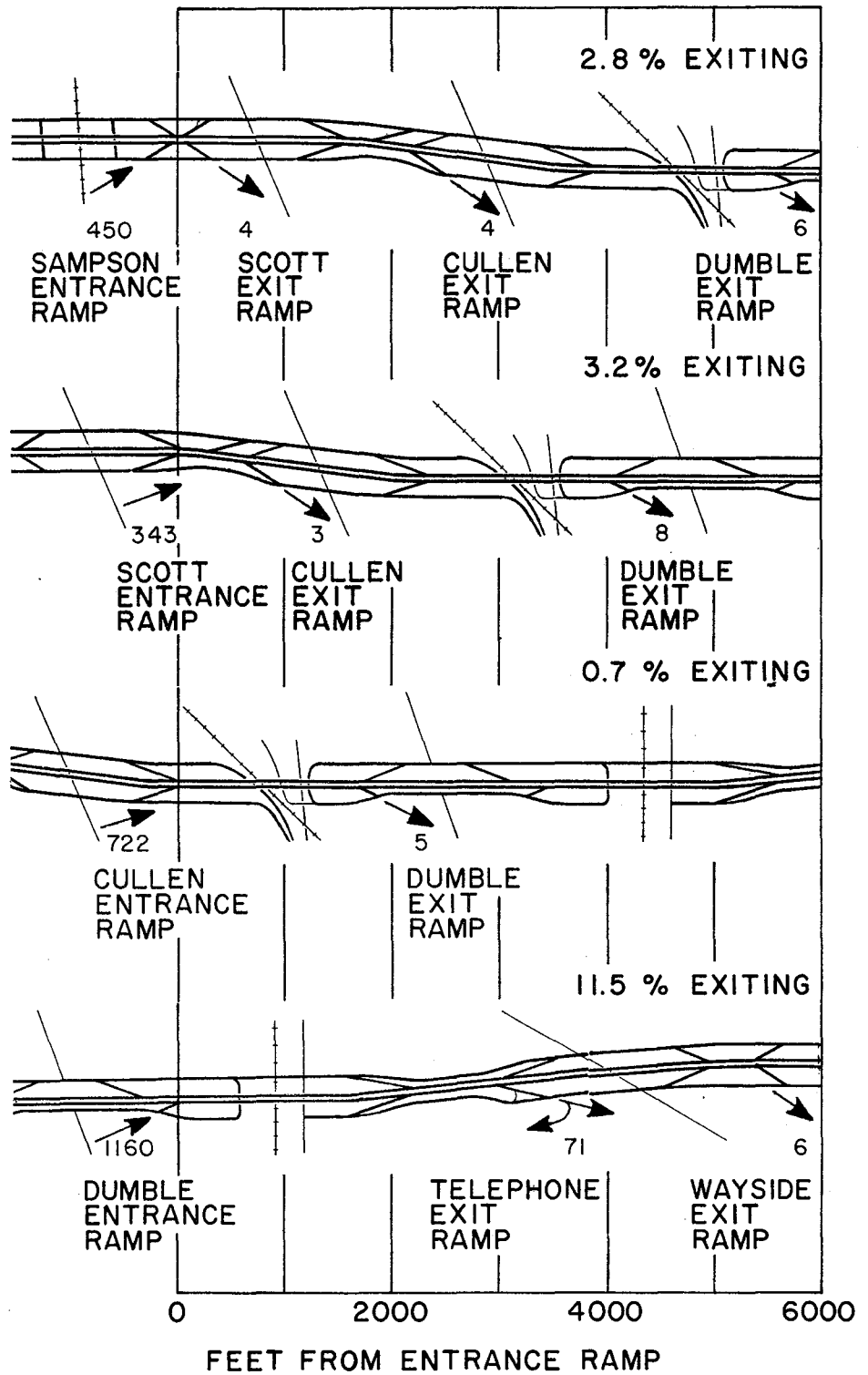

EXTENT OF SHORT TRIPS 4:00 - 6:00 P.M.  
 GULF FREEWAY - HOUSTON, TEXAS

FIGURE 23

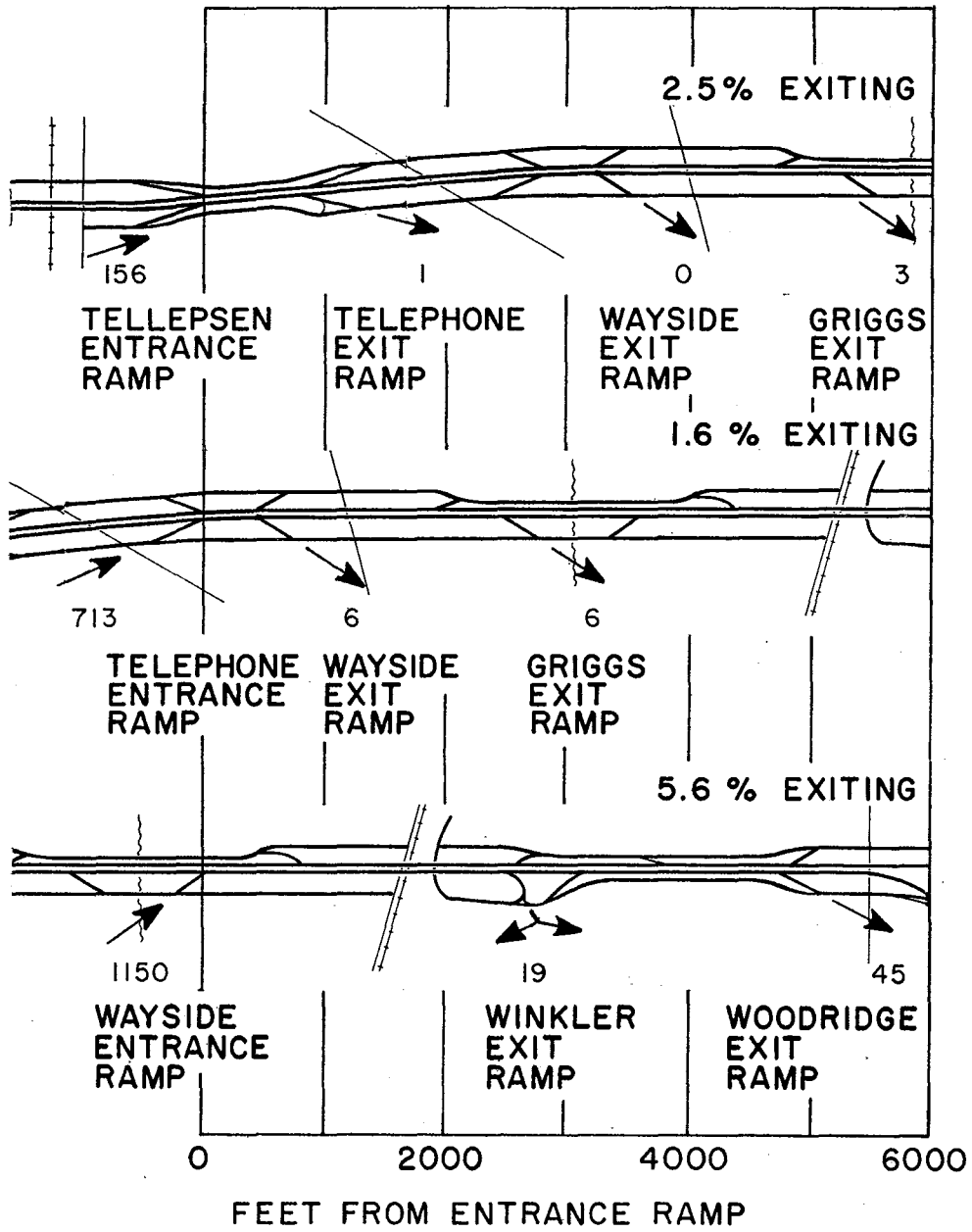

EXTENT OF SHORT TRIPS 4:00 - 6:00 P.M.  
GULF FREEWAY - HOUSTON, TEXAS

FIGURE 24

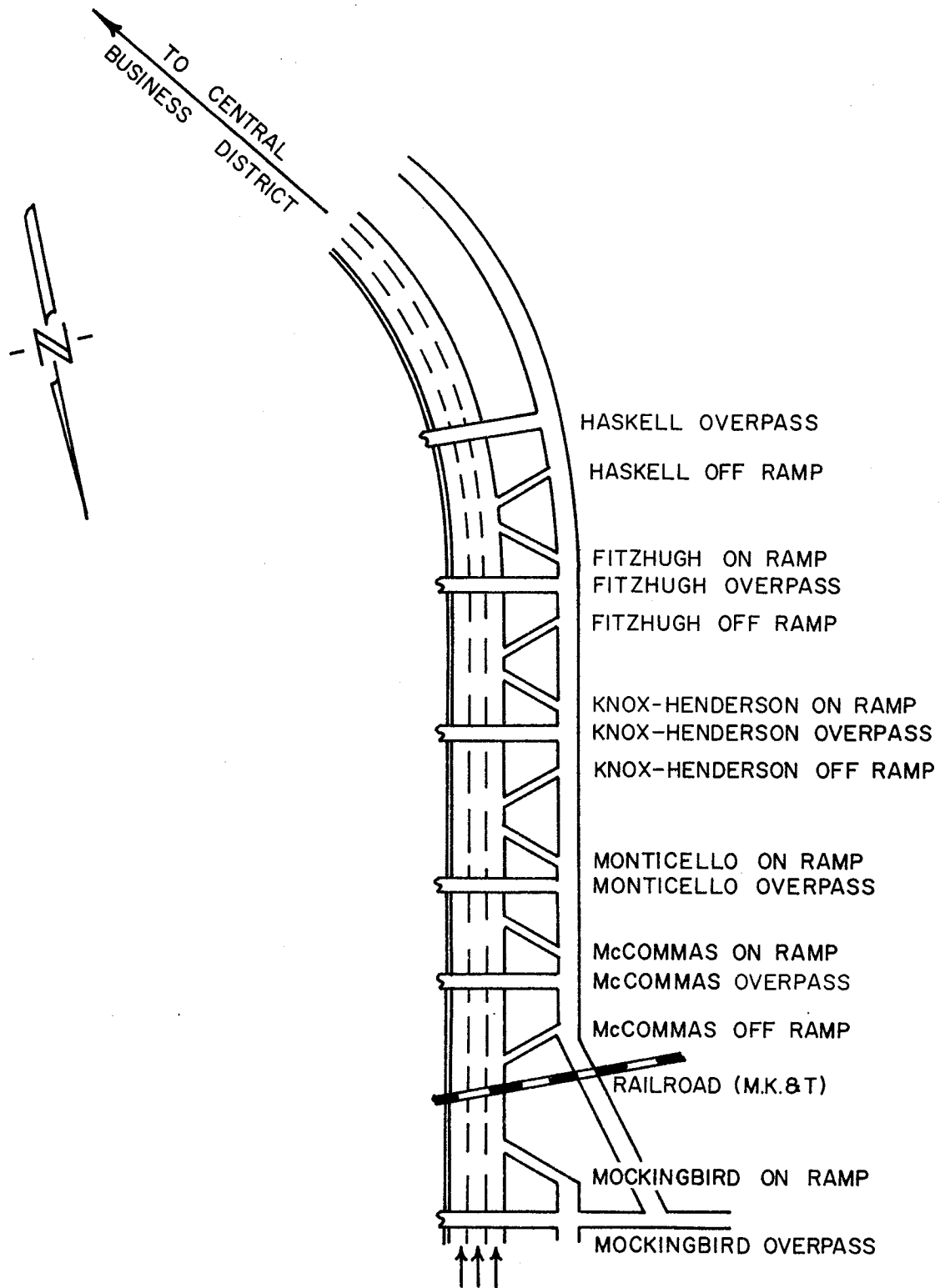

LIGHTS-ON STUDY AREA  
NORTH CENTRAL EXPRESSWAY DALLAS, TEXAS

FIGURE 25

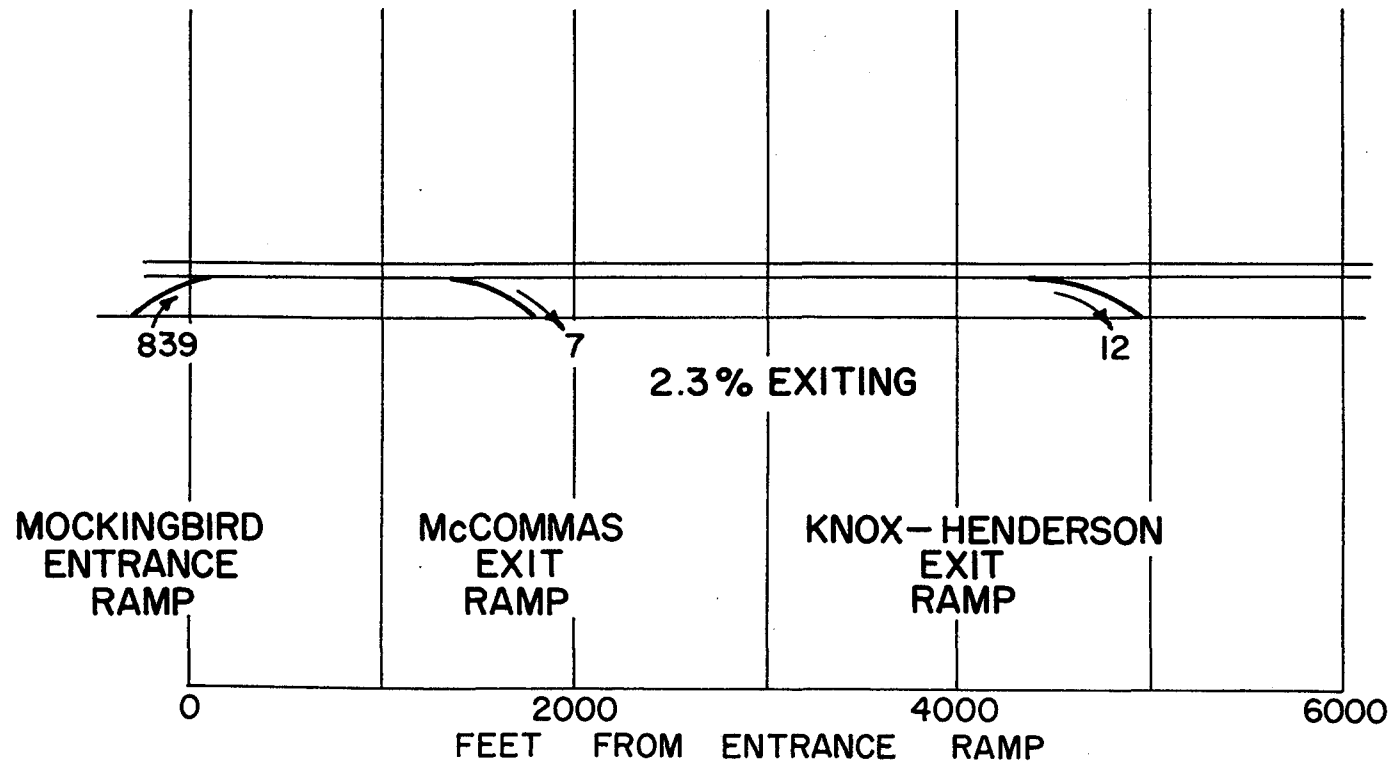

EXTENT OF SHORT TRIPS · 7:00 — 8:30 AM · NORTH CENTRAL EXPRESSWAY  
DALLAS, TEXAS

FIGURE 26

the freeway short trip route due to a high school just down the frontage road from the exit ramp studied. The study was conducted from 7:45 to 9:00 a.m. on a school day. The study location is illustrated in Figure 27.

Figure 28 illustrates the amount of traffic entering the Camp Bowie entrance ramp eastbound (1013 vehicles) during the 7:45-9:00 a.m. study period and the number of those vehicles which exited at the Pentecost exit ramp (135 vehicles). A significant amount of short trips (13.3% of those entering) were generated at this location which travel the 1570-foot trip on the freeway rather than use the difficult frontage road route shown in the sketch.

### Conclusion

The generation of short trips does not become a critical factor except during the peak periods of travel when most facilities have more traffic demand than they can accommodate. The results shown in Table 7 are short trips which occurred during these critical periods. As shown in Table 7, there was a distinct difference in the percentage of short trips in almost all cases where the frontage road was discontinuous or a difficult route was required. At locations with continuous frontage roads, short trips range from 1 to 4 per cent while at locations with discontinuous frontage roads or difficult surface street routing, short trips generally range from 5 to 20 per cent.

It was concluded that discontinuous frontage road or a difficult surface street route can usually be expected to create short trips during critical periods of freeway operation. It is recommended that frontage roads be continuous to eliminate an undesirable number of short trips during peak periods.

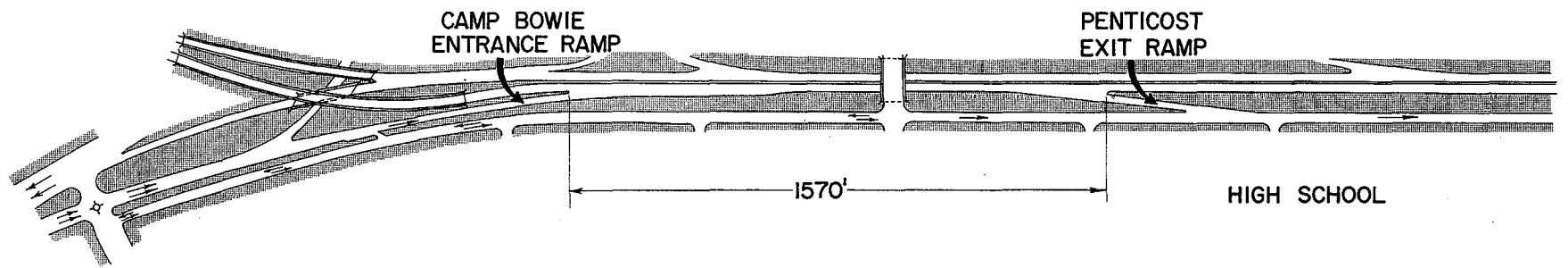

LICENSE PLATE STUDY AREA  
I.H. 20 FT. WORTH

FIGURE 27

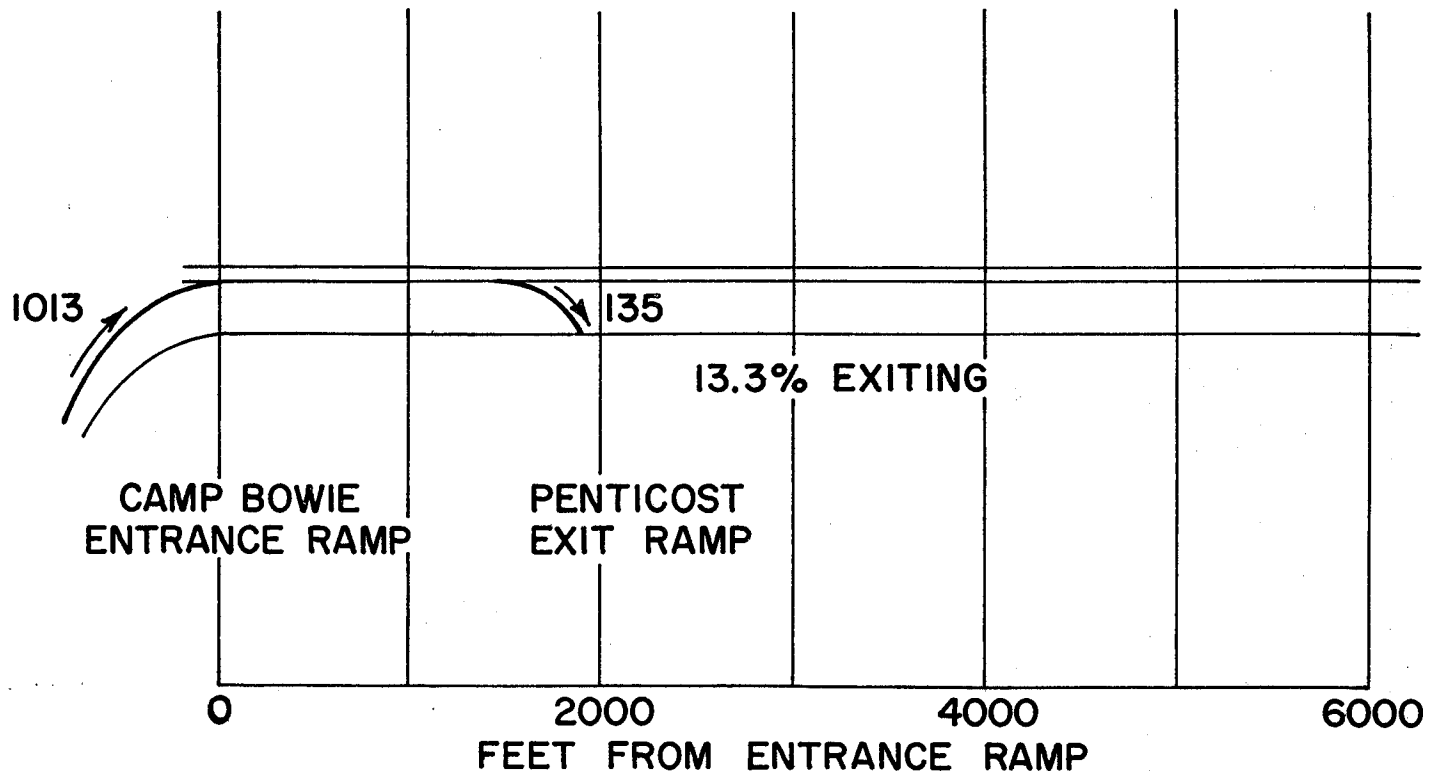

EXTENT OF SHORT TRIPS 7:45 - 9:00 AM I.H. 20 FT. WORTH, TEXAS

FIGURE 28

TABLE 7

## TABLE OF RESULTS

Vehicles Entering At:	Continuous Frontage Road		Discontinuous Frontage Road or Difficult Route	
	Percent Exiting	Quantity Exiting	Percent Exiting	Quantity Exiting
<u>Gulf Freeway</u>				
SH 225 Inbound	0.5%	4	--	--
SH 35 Inbound	--	--	7.3%	88
Woodridge Inbound	--	--	8.3%	51
Mossrose Inbound	--	--	22.5%	169
Griggs Inbound	3.7%	37	--	--
Wayside Inbound	1.7%	9	--	--
Telephone Inbound	--	--	13.4%	80
Dumble Inbound	--	--	5.4%	30
S. Cullen Inbound	1.4%	6	--	--
N. Cullen Inbound	3.3%	10	--	--
Sampson Outbound	2.8%	14	--	--
Scott Outbound	--	--	3.2%	11
Cullen Outbound	--	--	0.7%	5
Dumble Outbound	--	--	11.5%	134
Tellepsen Outbound	2.5%	4	--	--
Telephone Outbound	1.6%	12	--	--
Wayside Outbound	--	--	5.6%	64
<u>North Central Expressway</u>				
Mockingbird On-Ramp	2.3%	19	--	--
<u>IH 20 - Ft. Worth</u>				
Camp Bowie On-Ramp	--	--	13.3%	135



## WEAVING MANEUVERS

As the frequency of interchange points on a freeway increase, the length of weaving sections between entrance and exit ramps decrease and a potential weaving problem may be created. However, the full extent of weaving that may occur in a given freeway section due to the distribution of vehicles over the lanes of the freeway and desired exit movements was not well documented. It was entirely possible that most drivers exiting from a freeway would move to the outside lane a great distance in advance of the off-ramp which he used for an exit and, therefore, a greater number of exit ramps may not necessarily create weaving problems. This effect was studied using data from the "lights on" study of the North Central Expressway in Dallas.

### "Lights-On" Study

The "lights-on" study provided the opportunity to observe the lane use characteristics of the entrance ramp traffic under observation. These data were collected by observers stationed on overpasses. These observers noted the lane use and license number of each vehicle whose headlights were burning as it passed each station. With these data it was possible to study individual vehicle trips, to place the vehicle in a lane at each study station and to determine what exit ramp was used.

Figure 29 illustrates the lane use characteristics for vehicles entering at the Mockingbird on-ramp and exiting at the Knox-Henderson exit ramp, the Fitzhugh exit ramp and the Haskell exit ramp, respectively. These data indicate heavy use of the outside lane which would create practically no weaving problems at the exit locations.

### Conclusions

It was concluded from the study conducted that most on-ramp traffic which enters a freeway for a 1 to 2 mile trip, remains in lane 1 (right lane), and thus creates practically no weaving problems at the exit locations. Traffic making longer trips also tends to move to the outside lane well in advance of the desired exit point.

# NORTH CENTRAL EXPRESSWAY DALLAS, TEXAS

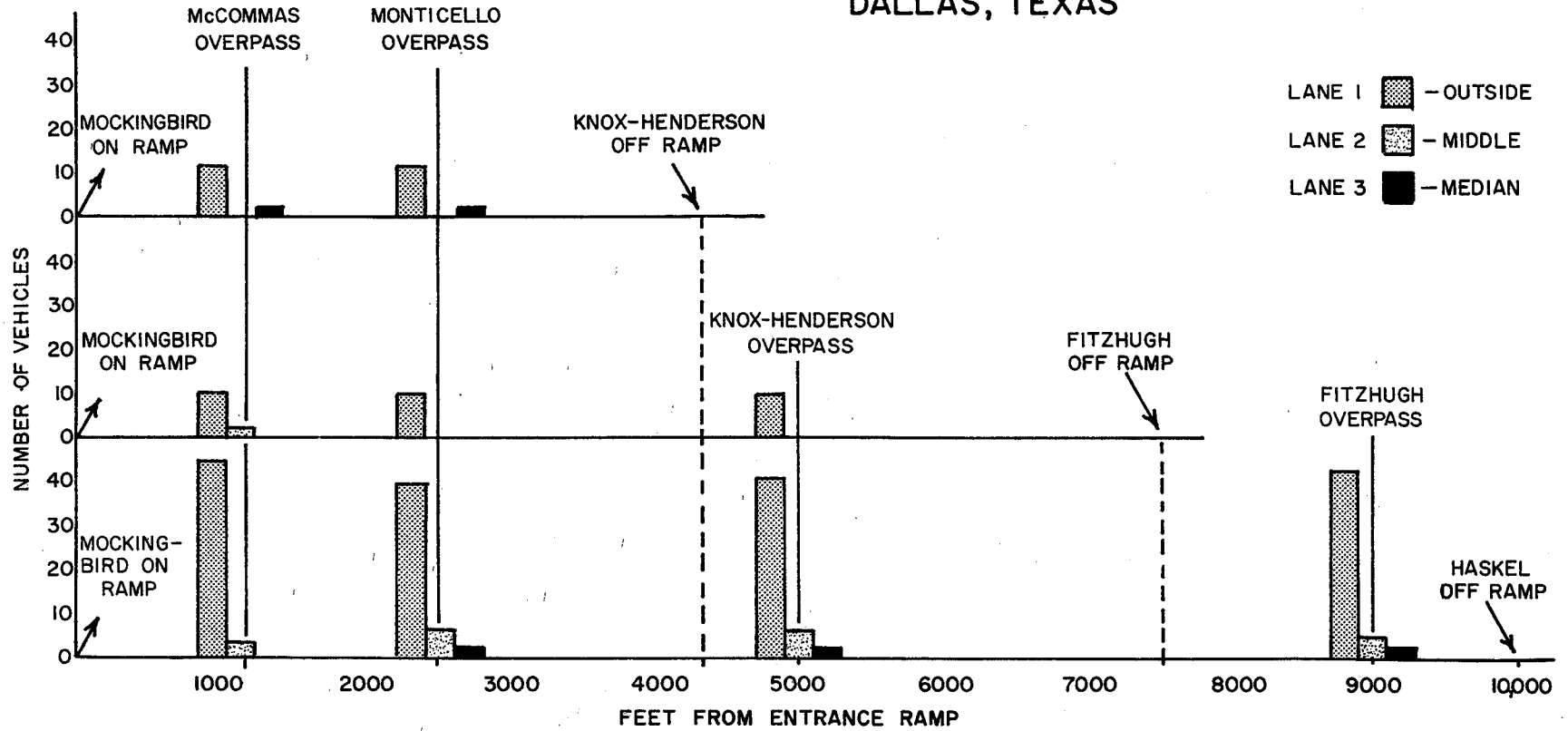

**ON-RAMP TRAFFIC LANE USE DISTRIBUTION 7-8:30 A.M.**

FIGURE 29

## ACCESS CONTROL

### Introduction to the Problem

The problem of access control on exit ramps has been brought to attention by numerous spectacular crashes involving vehicles which entered an exit ramp moving in the wrong direction and proceeded down the freeway going the wrong way. Also, data collected for the "Access Violations on Controlled Access Facilities" project indicated some improper usage of exit ramps as entrance ramps.

### Review of Current Literature

The Bureau of Public Roads completed a 1964 survey of the 50 states, the District of Columbia and Puerto Rico concerning wrong way movements.<sup>2,3</sup> Fifteen percent of the states said that a definite wrong way problem existed on their highways. California and New Jersey had completed studies in this area. The following similarities were found in their studies: more wrong way violations occurred where half-diamond interchanges were used; a large percentage of violations were due to willful mis-use of ramps or freeways, and older drivers accounted for a disproportionate number of wrong way violations. The California studies indicated a high proportion of wrong-way movements were made by intoxicated drivers.

Experience in several states refuted two generally accepted ideas. One was that it was anticipated that when drivers became accustomed to freeways that wrong way movements would cease, but this was found not to be the case. The second was the high volume locations would have few wrong way movements since the driver could identify the correct direction of traffic by observing other vehicles. But these mistakes have occurred in high volume locations, often resulting in fatal accidents.

Many states felt that intentional disobedience was one of the major causes of wrong way movements. A large number of wrong way movements were reported when a freeway facility was opened for the first time. These violations were usually made by local citizens who during construction became accustomed to using portions of the facility for their own convenience. The problem of wrong way movements was expected to increase as additional mileage of the Interstate System is completed.

It was the opinion of most states that proper application of existing signs was adequate to take care of most wrong way movements. Some states used stop signs facing the wrong way direction with supplemental messages such as "Do not Enter," "Turn Back," or "You Are Going The Wrong Way." The European "Do Not Enter" sign was being tested in four states and the District of Columbia.

The California Division of Highways has experimented with a wrong way detector and automatic sign device.<sup>4</sup> This device consisted of an illuminated and reflectorized white on red sign reading "Go Back-You Are Going Wrong Way," a 12-inch red traffic light, two horns, one steady, one pulsating, and a flashing amber signal to warn the legitimate off-ramp traffic of the presence of a wrong way vehicle. A movie camera was interconnected to this device which filmed a 15-second sequence each time a wrong way maneuver was detected. At the time of the writing, insufficient data have been obtained to make any definite conclusion. The following has been noted thus far:

1. There were approximately 15 wrong way entries per month.
2. The entries were almost equally divided between day and night.
3. Nine out of ten wrong way drivers were observed to stop before they passed the automatic sign.  
(Others may have stopped after moving out of the camera's field of view.)

The California Division of Highway also studied the use of one-way spike barriers for a positive wrong way control.<sup>4,5</sup> This method of control was discarded since drivers moving in the proper direction could not tell which way the spikes were pointing, and at high speeds the errant drivers may have difficulty maintaining control of their vehicle after four blowouts. Furthermore, the presence of a disabled vehicle on a high speed exit ramp was not desirable.

#### Considerations in the Design of a Directional Detector

In order to determine the extent of wrong way maneuvers at an exit ramp, a directional detector would be required. When this research was initiated, there were no commercial directional detectors available which could detect wrong way movements for the wide speed ranges which occur on exit ramps. Thus, a study was made to consider the design of a directional detector which could be used to collect these data. Two designs of directional detectors were considered.

#### Design No. 1 - A Two-Detector Unit

An attempt was made to design a directional counter which could be used to detect and count wrong way maneuvers using two detectors. This unit would operate as follows when assuming that a vehicle was passing in the wrong way direction: The first detector the vehicle passed, detector No. 1, would "arm" the second detector, detector No. 2. Detector No. 2 could then detect the wrong way vehicle as it passed and

cause a count to be registered. This would be accomplished by detector No. 1 energizing an arming relay for a short period of time using a monostable multivibrator as the timing mechanism. Detector No. 2 would utilize a relay wired in series with the arming relay. The cost of the electrical parts per unit would be approximately \$25.00. The entire system would have to include two detectors, one counter, and batteries plus the electrical parts.

The reliability of this unit would be limited to a very small range of vehicle speeds. This range was determined by the space between the two detectors, the time that the arming circuit stays energized, and the distance between axles of a tandem truck or trailer.

The two detectors could be no closer than one foot apart or a large truck tire might be detected by both detectors at the same time. This would give a false indication of a wrong way vehicle. The arming circuit would be designed to stay energized for 0.1 second. A slow-moving vehicle crossing the two detectors would not be counted if it were moving at a speed less than 1 foot per 0.1 second or 6.7 mph. The 1-foot traveled was the distance between the two detectors. The solution to this problem would seem to be to increase the time that the arming circuit stays energized.

But the investigation of a tandem truck or trailer traveling in the correct direction showed that this time could not be increased. The twin axles of such a vehicle were on approximately 4.5-foot centers. Assuming that two feet of each tire touched the ground, the distance on the ground between the tires was 2.5 feet. When going in the correct direction, the following tire would have to travel one-foot less or 1.5 feet since it has only to contact the number 2 detector. In operation, the first wheel would cross the number 2 detector with no effect since it was not armed, then hit the number 1 detector which armed the number 2 detector. The second wheel then traveled 1.5 feet to hit the armed number 2 detector. If the truck were traveling at a speed faster than 1.5 feet per 0.1 second or 10.2 mph, a false count would result. Thus, the reliability of this design was limited to a very small speed range no matter how long the arming relay was energized. (In this case between 6.7 and 10.2 mph.)

#### Design No. 2 - A Multiple Detector Unit

A four detector system might eliminate some of the problems of the two detector system. In the four detector system, the first detector would clear all previous detections and arm the remainder of the unit to

operate. The next three detectors would have to be tripped in sequence to count a wrong way vehicle. The last detector would also turn the system off until the first detector was actuated again. In this manner a vehicle traveling in the correct direction would first turn the system off before crossing the other detectors which would result in no count. This type of system contained no timers and thus the range of speeds was unlimited.

The electronics of this system would be complex requiring multiple contact relays. It was estimated that each unit would cost a minimum of \$100.00. In addition to this cost each entire system would require four detectors, one counter, and batteries. To collect sufficient data on wrong way maneuvers, many locations would have to be studied due to the infrequency of this type of maneuver. As many directional detectors would be required as study locations. Due to the cost of a large quantity of directional detectors, this system was not built and tested.

#### Commercial Directional Detectors

Since the beginning of this project, two commercial detectors have appeared on the market. Each of these directional detectors were advertised to operate over any range of vehicle speeds.

Gammatromix Inc. advertised the DR-21 Directional Presence Detector. This unit utilized two detector probes which must be placed under the pavement. The unit operated with 110 volt current. The advertised price of one unit with two probes was \$425. For the data collection phase of this project, the permanent installation under the pavement and the requirement of 110 volt current were disadvantages.

The Radio Corporation of America (RCA) has advertised a directional vehicle detector specifically for sensing wrong way maneuvers. Their device operated from two wire loops embedded in the pavement. This unit had the same disadvantages as the first unit discussed.

## CONCLUSIONS

On the basis of studies conducted in connection with the off-ramp project the following conclusions were established.

1. On freeways where continuous frontage roads exist, the provision of numerous entrance and exit ramps on a freeway does not necessarily tend to create a large number of short trips. The data developed in this study indicated that the number of short trips on a freeway increase rapidly at locations of discontinuous frontage roads or difficult surface street routings. The need for continuous frontage road systems to eliminate short trip movements is emphasized.

2. On the basis of the locations studied, it was found that off-ramps do not create an extensive freeway weaving problem. A majority of freeway trips of lengths from one to two miles remain in the outside lane of the freeway for the trip. Traffic making longer trips also tends to move to the outside lane well in advance of the desired exit point.

3. The problem of wrong way entries on an exit ramp is a very serious one and is worthy of a study in itself. It would be desirable to determine the extent of wrong way maneuvers and to relate these maneuvers to elements of design and control.

## BIBLIOGRAPHY

1. McCasland, William R. "Traffic Characteristics of the Westbound Freeway Interchange Traffic of the Gulf Freeway," Research Project Number 2-8-61-24, Report # 7, Texas Transportation Institute, October, 1964.
2. \_\_\_\_\_ . "Traffic Safety," Volume 65, Number 1, January 1965, pp 10-11.
3. \_\_\_\_\_ . "Traffic Engineering," January, 1965, pp 24-27.
4. Doty, R. N. and Ledbetter, C. R. "Full Scale Dynamic Tests on One-way Spike Barriers," Published by State of California, Department of Public Works, Division of Highways, Traffic Department, January 1965.
5. Tamburri, T. N. and Theobald, D. J. "Wrong Way Driving (Phase II)," Published by State of California, Department of Public Works, Division of Highways, Traffic Department, February, 1965.



THE EFFECTS OF OFF-RAMPS ON FREEWAY OPERATION AS  
RELATED TO ACCESS PROVISION

by

William E. Tipton  
and  
Charles Pinnell

Research Report Number 59-3

Off-Ramps on Freeway Operation  
Research Project Number 2-8-63-59

Sponsored by  
The Texas Highway Department  
In Cooperation with the  
U. S. Department of Commerce, Bureau of Public Roads

October 1965

TEXAS TRANSPORTATION INSTITUTE  
Texas A&M University  
College Station, Texas

## INTRODUCTION

### Statement of the Problem

Many freeways within our major cities are entering a critical phase of utilization. These facilities are becoming congested during peak periods, and are not providing the "level of service" for which they were designed. All possible courses of action should be undertaken to improve the efficiency of freeway operation so that a desired level of service can be maintained.

Past studies aimed at improving the efficiency of operations have primarily dealt with the design and operation of an on-ramp, the design and operation of an off-ramp, or the weaving on the freeway resulting from an on-ramp closely preceding an off-ramp.<sup>1-10</sup> Existing freeway interchanges have been designed using the current "best" design for each of the ramps, but the location and configuration of the ramps have for the most part been accomplished in a standardized manner.

Ramp location, as used herein, was defined as the location of a ramp or ramps upstream or downstream of an arterial street crossing the freeway. Ramp configuration was defined as the order in which closely spaced pairs of ramps appear. A pair of ramps includes an on-ramp and an off-ramp; therefore, a ramp configuration would be an off-ramp closely followed by an on-ramp or vice versa. "Stacked" ramps, a modification of the off-ramp followed by an on-ramp configuration, exists in the form of grade separated ramps. An illustration of stacked ramps is shown in Figure 30.

Names of interchange designs have resulted from the standardization of ramp configuration. The most prominent of these are the "X" interchange and the diamond interchange. The "X" interchange includes an on-ramp upstream of the arterial street and off-ramp downstream of the arterial street for both the inbound and the outbound directions of travel. As illustrated in Figure 30, these four ramps form an "X" from which this type of interchange derived its name. In the diamond interchange, the ramps are the reverse of those in the "X" interchange, and the four ramps form a diamond. This type of interchange is also illustrated in Figure 30.

To properly design interchanges, the ramps must be located in such a manner as to fulfill the estimated future needs of traffic and provide a minimum of interference to the freeway traffic. This research

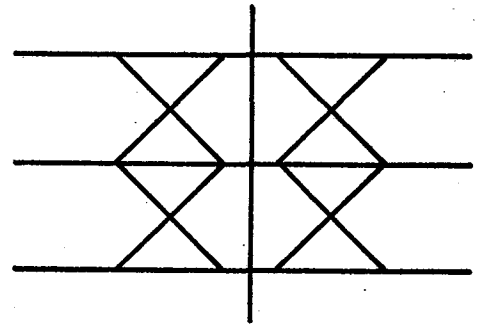
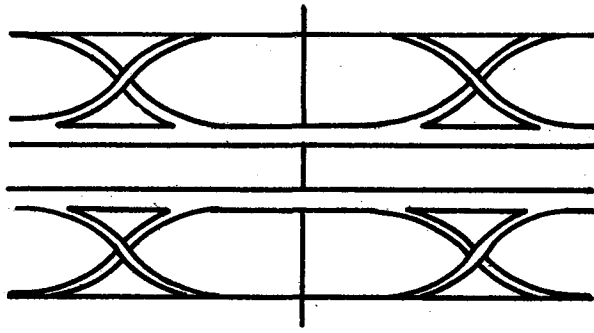

**STACKED RAMPS**

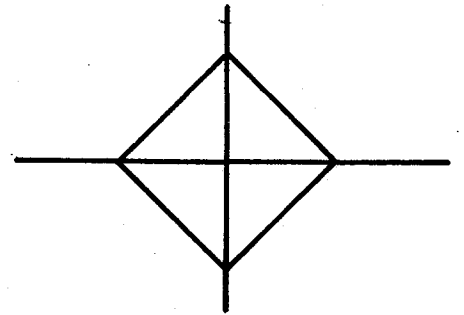
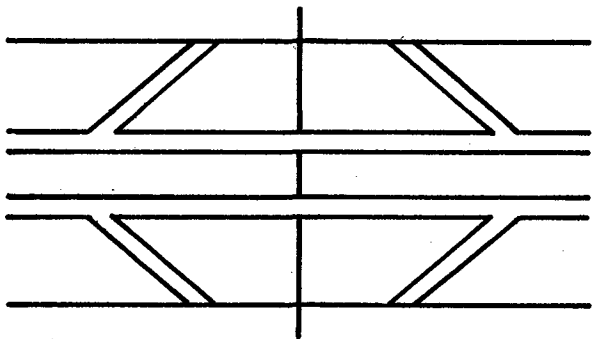

**DIAMOND INTERCHANGE**

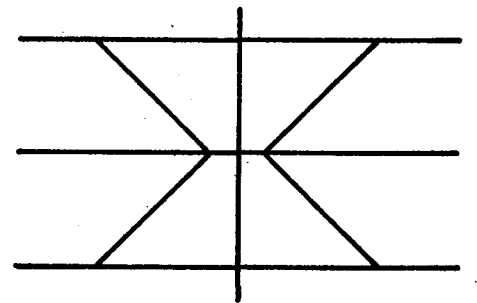
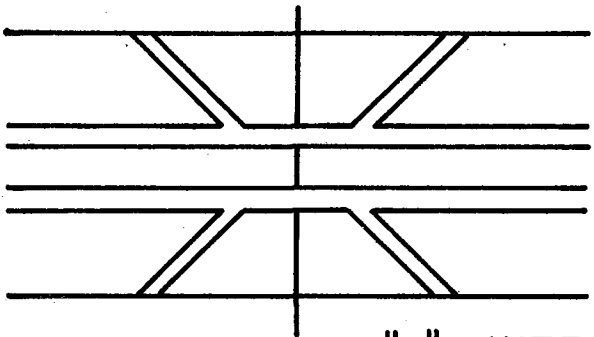

**"X" INTERCHANGE**

**INTERCHANGE TYPES**

FIGURE 30

investigated the operation of several existing layouts and the suitability of different layouts being used at these locations. The stacked ramp configuration was investigated as a possible solution when both an on-ramp and an off-ramp were required at the same location.

This research was a portion of a larger project, "The Effects of Off-Ramps on Freeway Operation," which was conducted by the Texas Transportation Institute in cooperation with the Texas Highway Department and the U. S. Bureau of Public Roads.

### Study Objectives

The objectives of this phase of the project were:

1. To investigate the desired movement of entering and exiting traffic at diamond or "X" type interchanges.
2. To investigate the effect of freeway ramp configuration on the amount of acceptable gap time available to vehicles desiring to enter the freeway at a specific ramp, in order to determine the more desirable ramp configuration.
3. To investigate the effect on the amount of acceptable gap time as the distance downstream of an off-ramp increased, in an attempt to develop criteria for ramp spacing.
4. To investigate the suitability of various interchange layouts in fulfilling drivers' desires, providing access to the freeway and abutting property, and reducing the interference to freeway and arterial street traffic.

### Study Site

All of the studies for this research took place on the Gulf Freeway in Houston, Texas. This freeway is a six-lane facility divided by a four-foot barrier type median. The grade of the Gulf Freeway is near ground level with the exception of the interchanges and railroad crossings. At these locations the freeway rises to pass over an arterial street or railroad. This up and down movement creates a "roller coaster" effect which is shown in the aerial photograph in Figure 31. For the most part, continuous frontage roads parallel this facility. The study sites were located between Dowling Street, which is two miles from the central business district (CBD), and the Reveille Interchange, which is six miles from the CBD. Figure 32 shows the study area and the freeway layout.



GULF FREEWAY  
HOUSTON, TEXAS

FIGURE 31

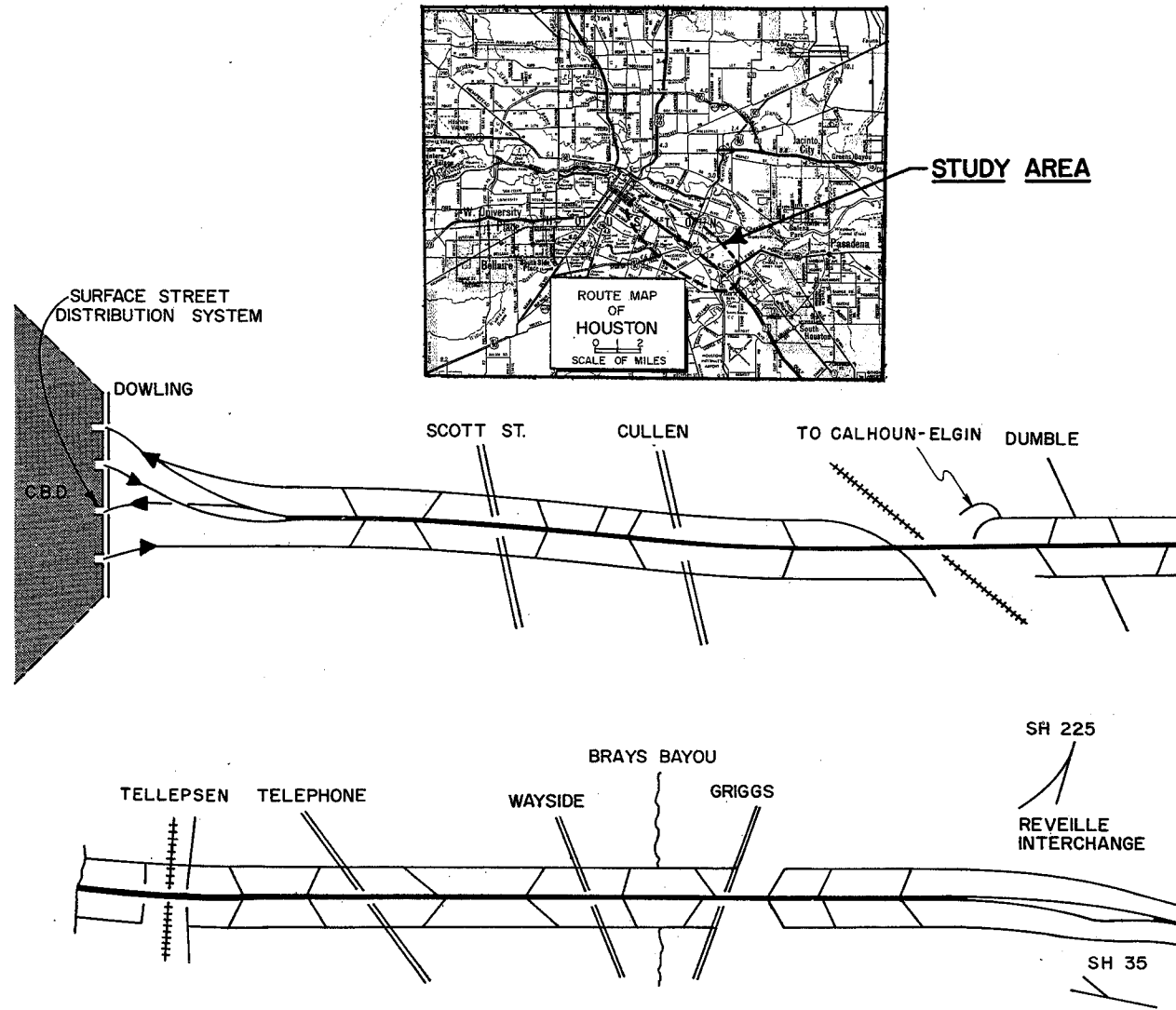

STUDY AREA - GULF FREEWAY  
HOUSTON, TEXAS

FIGURE 32

## DRIVERS' DESIRES AT INTERCHANGES

### Introduction to the Problem

The investigations of the desired movement of entering and exiting traffic at various interchanges were conducted to determine if drivers' desires were the same at most interchanges. If they were, the indication would be that a standard type of interchange (with standard ramp locations) could fulfill drivers' desires, and the procedure of using a standard type of interchange along a section of freeway would be justified. If drivers' desires were not the same at all interchanges, the indication would be that each interchange layout should be based on the anticipated traffic desires for that interchange, and the ramps placed according to these desires.

### Method of Study

Drivers' desires at each of the **interchanges** studied were determined by a license plate survey. The survey was divided into four studies to investigate each possible desire. These studies were:

Study 1: The Desire to Exit Downstream of the Arterial Street.

Study 2: The Desire to Exit Upstream of the Arterial Street.

Study 3: The Desire to Enter Upstream of the Arterial Street.

Study 4: The Desire to Enter Downstream of the Arterial Street.

Data for each of these studies were collected at the following interchanges:

1. Cullen Interchange Outbound.
2. Telephone Interchange Outbound.
3. Wayside Interchange Outbound.
4. Woodridge Interchange Outbound.
5. Cullen Interchange Inbound.

The data collection periods were from 4:00 to 5:30 P.M. at the first four interchanges listed above and from 6:30 to 8:00 A.M. at the fifth interchange.

With one exception (Wayside Interchange), the data for the four studies were collected at diamond interchanges. As noted previously, a diamond interchange has an off-ramp upstream of the arterial street and an on-ramp downstream of the arterial street. Studies 1 and 3 were conducted at diamond interchanges even though the ramps fulfilling the desires in question did not exist. These desires were determined by recording the license plate number of vehicles that could have used ramps, had they existed, and matching these license plate numbers to those recorded at the ramps actually used. The procedure used for each study is illustrated in Figure 33 and explained in detail below.

#### Study 1: The Desire to Exit Downstream of the Arterial Street

For Study 1, license plate numbers were recorded at Points A and B (See Figure 33). Point A was on the existing off-ramp, and Point B was located on the frontage road, 500 feet downstream of the bridge abutment. Point B was chosen as the nearest location to the arterial street which could be served by an off-ramp located downstream of the arterial street. The amount of license plate numbers matched between Points A and B was the extent of the desire to exit downstream of the arterial street.

#### Study 2: The Desire to Exit Upstream of the Arterial Street

License plate numbers of vehicles using the off-ramp, Point A, were recorded entering private property and access streets, Point E, and turning left, Point D, or right, Point C, onto the arterial street (see Figure 33). The amount of license plate numbers matched between Point A and Points C, D, and E was the extent of the desire to exit upstream of the arterial street.

#### Study 3: The Desire to Enter Upstream of the Arterial Street

For Study 3, license plate numbers were recorded at Points F and G. Point F was located on the frontage road, 700 feet upstream of the bridge abutment. This point was used as the nearest location to the arterial street for which an on-ramp upstream of the arterial street could provide access. Point G was located on the existing on-ramp downstream of the arterial street. The extent of the desire to enter upstream of the arterial street was determined by the amount of license plate numbers matched between Points F and G.

#### Study 4: The Desire to Enter Downstream of the Arterial Street

License plate numbers were recorded of vehicles entering the frontage



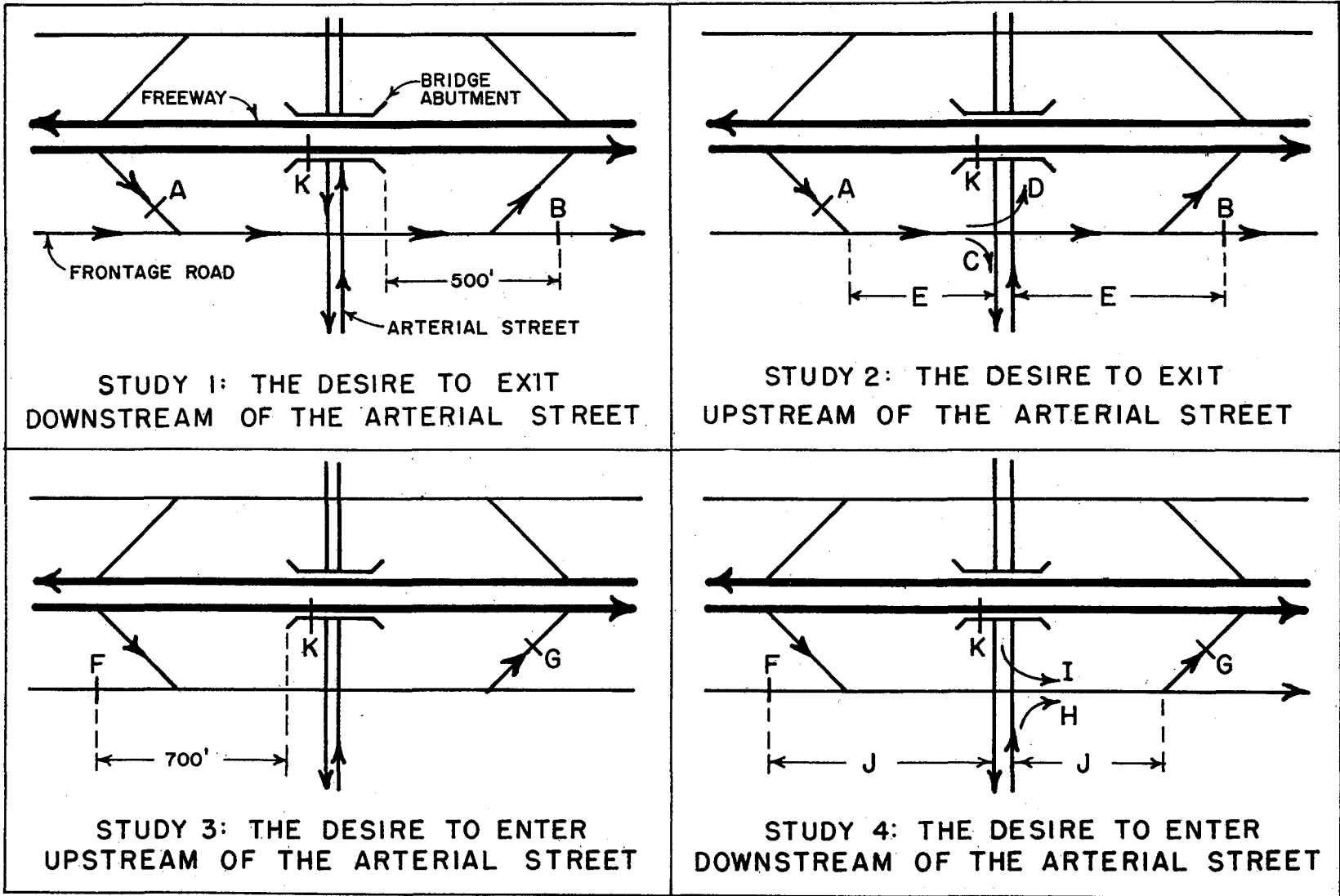

**LICENSE PLATE RECORDING POINTS**

FIGURE 33

road from private property and access streets, Point J, turning left, Point I, and right, Point H, from the arterial street onto the frontage road, and entering the on-ramp, Point G. The amount of license plate numbers matched between Point G and Points H, I, and J was the extent of the desire to enter downstream of the arterial street.

In addition to the license plate survey, the freeway volume crossing the overpass in the direction of travel under study, Point K, was counted in five-minute periods to furnish an indication of freeway operation during the study. Data were collected for all four studies simultaneously at each interchange to avoid unnecessary duplication of recording points.

Some method of determining if traffic desired a specific ramp was required. It was decided that if the extent of the drivers' desires for a ramp was greater than 100 during the peak hour, the ramp would be deemed to be desired. This value is not necessarily practical or to be construed as a warrant for the construction of a ramp. In all cases the actual desires are indicated so that the individual reader may evaluate the situation according to his own judgement.

### Discussion of Results

#### Cullen Interchange Outbound

The results of the investigation of drivers' desires at the Cullen Interchange Outbound are shown in Figure 34. These desires indicated that an off-ramp located downstream of the arterial street was desired in addition to the existing ramps. Thus, at the Cullen Interchange Outbound, traffic desired an off-ramp upstream of the arterial street, and an on-ramp and an off-ramp downstream of the arterial street.

#### Telephone Interchange Outbound

The traffic desires at the Telephone Interchange Outbound are shown in Figure 35. These desires indicated that only the existing ramps were desired. At this interchange, an off-ramp located upstream of the arterial street and an on-ramp located downstream of the arterial street were desired.

#### Woodridge Interchange Outbound

At the Woodridge Interchange Outbound, drivers' desires indicated that an off-ramp downstream of the arterial street was desired in addition to the existing ramps. The traffic desires are shown in Figure 36. Therefore,

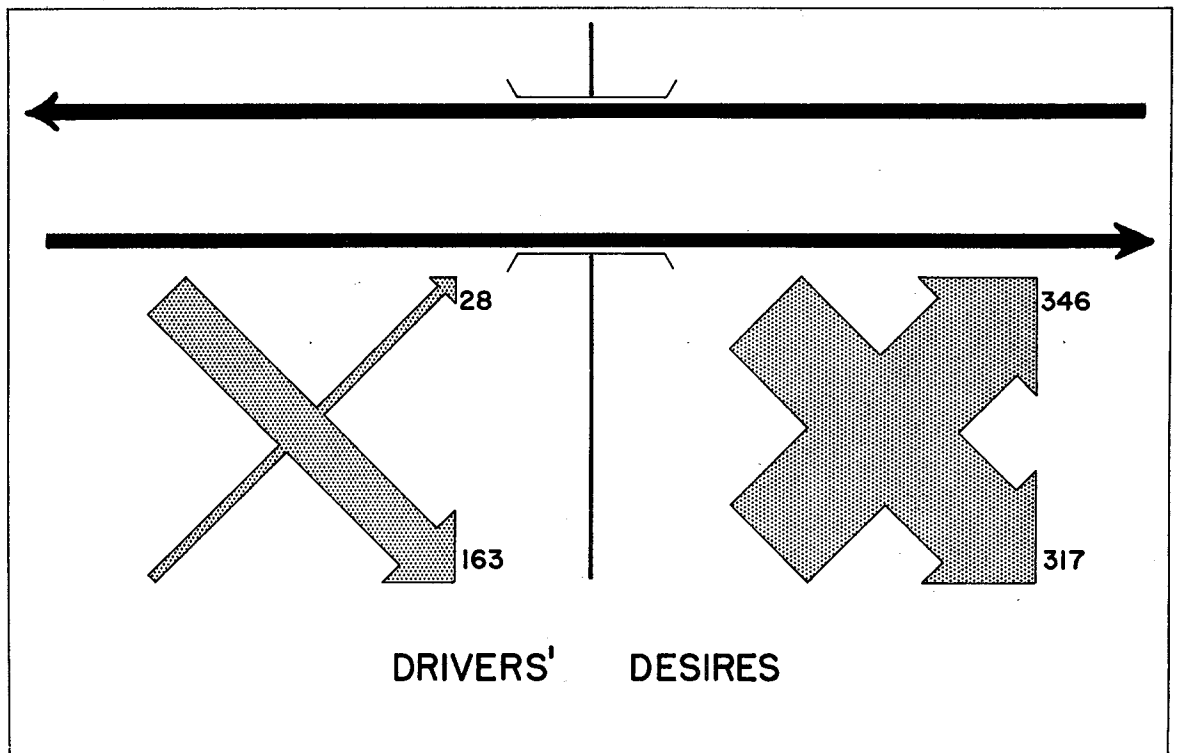
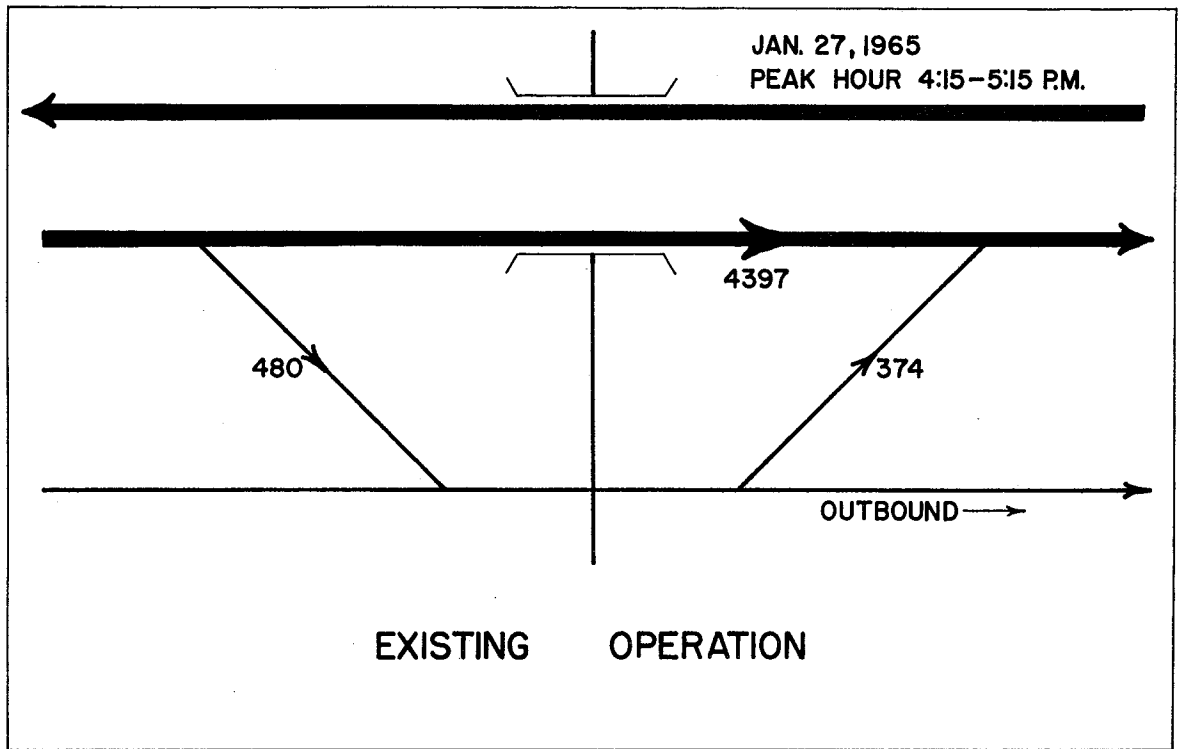

CULLEN INTERCHANGE OUTBOUND

FIGURE 34

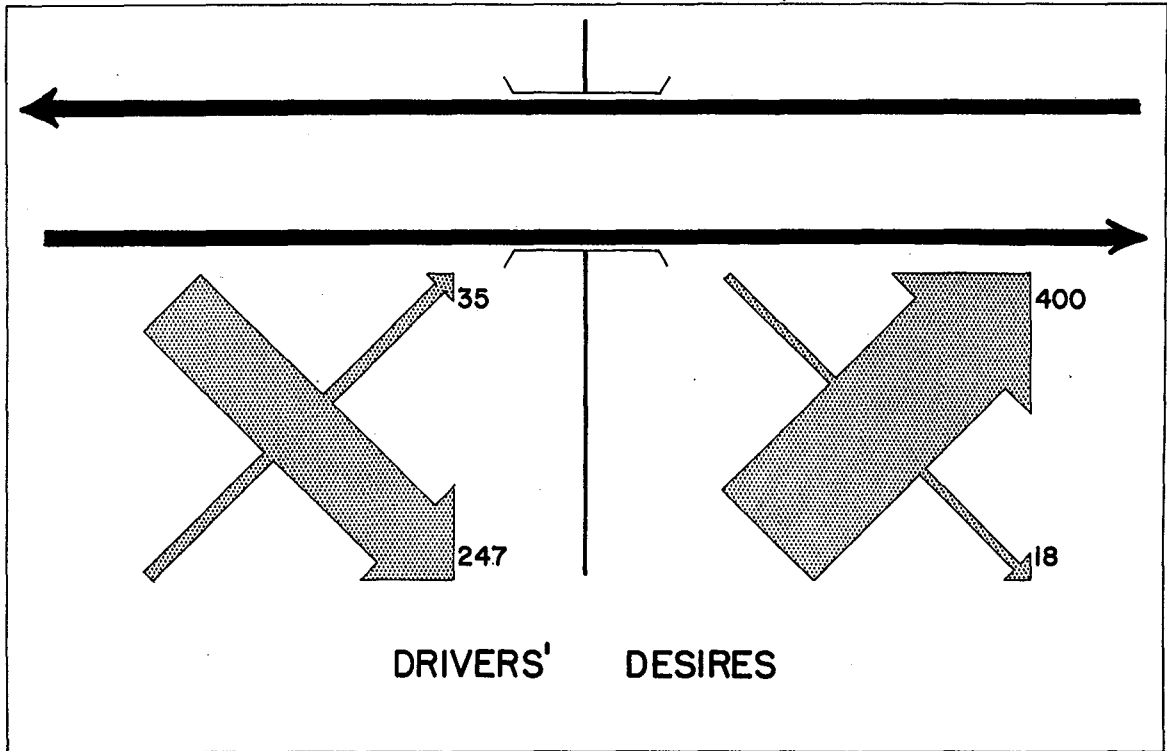
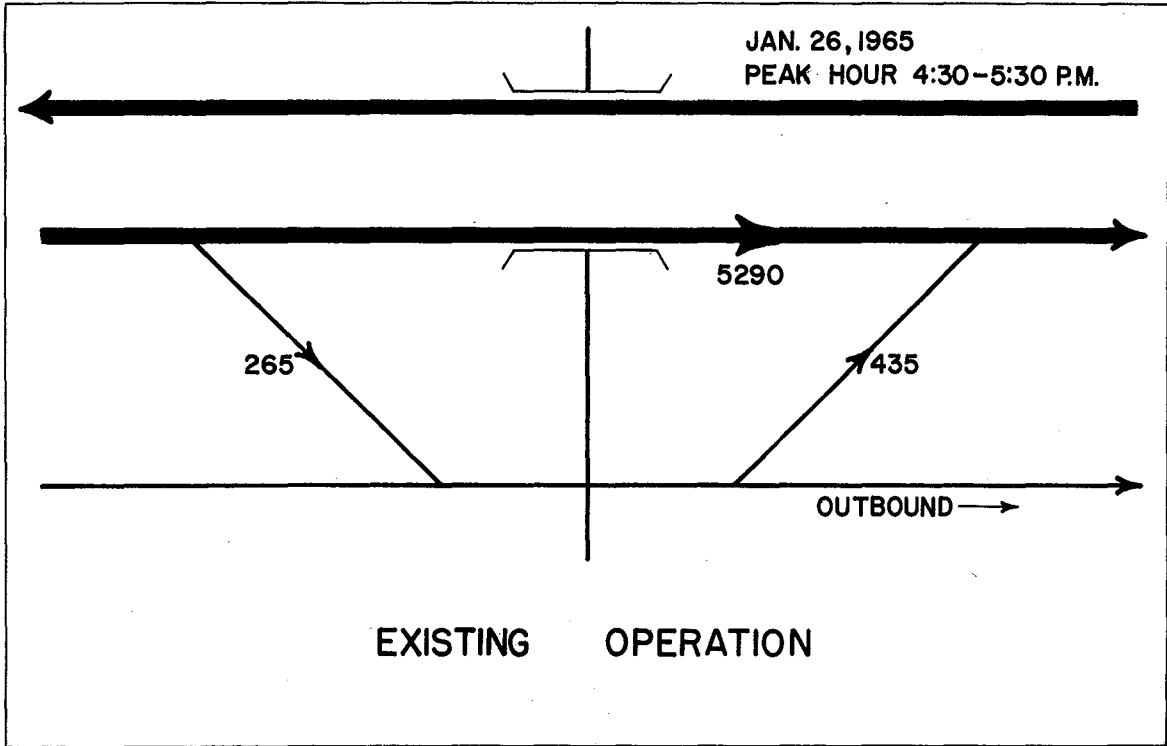

TELEPHONE INTERCHANGE OUTBOUND

FIGURE 35

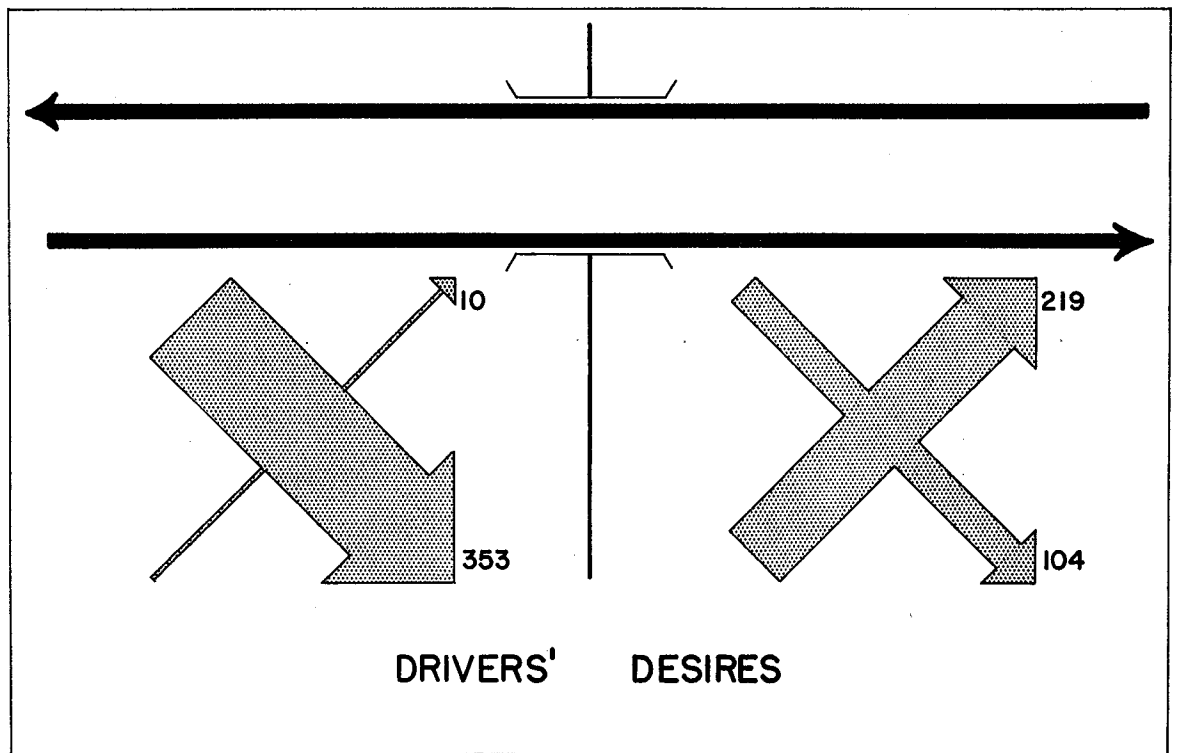
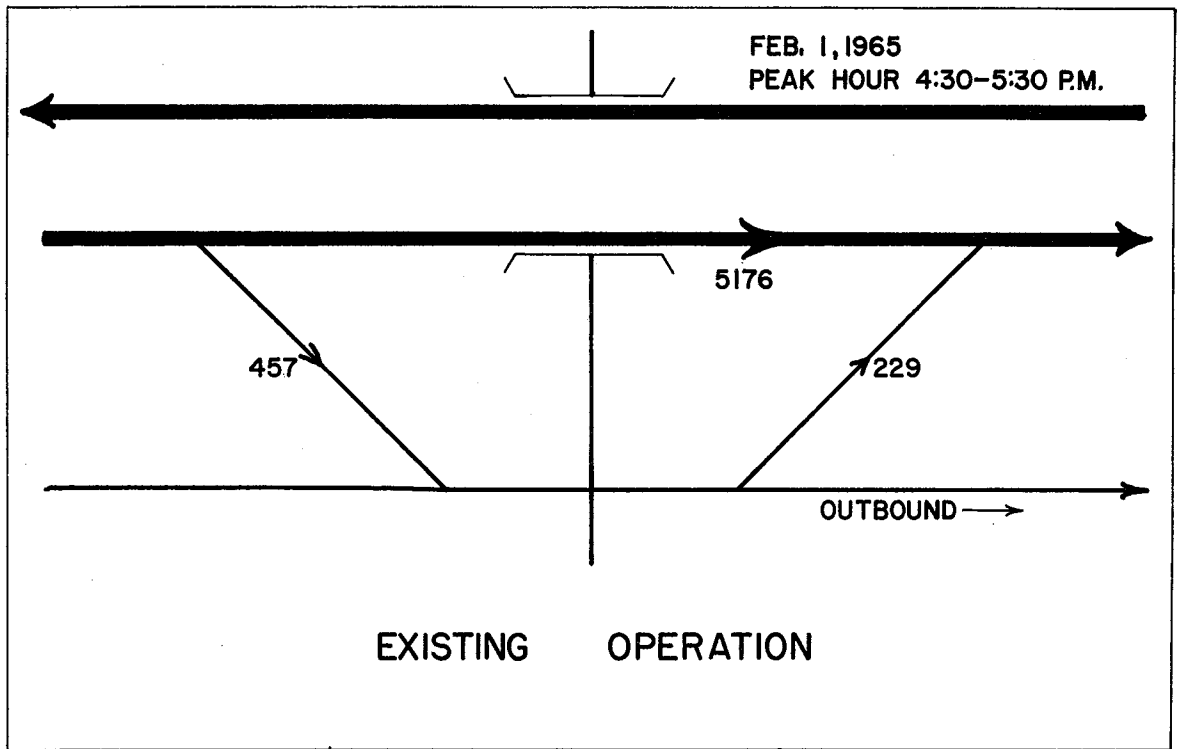

WOODRIDGE INTERCHANGE OUTBOUND

FIGURE 36

an off-ramp upstream of the arterial street, and an on-ramp and an off-ramp downstream of the arterial street were desired at the Woodridge Interchange Outbound.

### Wayside Interchange Outbound

Drivers' desires at the Wayside Interchange Outbound are shown in Figure 37. These desires indicated that each of the ramps in the existing interchange were desired. (The existing interchange was assumed to have included the on-ramp downstream of Telephone Road.) Thus, an on-ramp and an off-ramp were desired upstream and downstream of the arterial street.

### Cullen Interchange Inbound

The results of the investigation of drivers' desires at the Cullen Interchange Inbound are shown in Figure 38. The desired movements indicated that an on-ramp was desired upstream of the arterial street in addition to the existing off-ramp, and that one of the existing on-ramps located downstream of the arterial street was desired. Therefore, at the Cullen Interchange Inbound, an on-ramp and an off-ramp were desired upstream of the arterial street, and one on-ramp was desired downstream of the arterial street.

### Conclusions

The results of the investigation of drivers' desires at interchanges illustrated that the desires differed at the five interchanges studied, and that various combinations of ramps were required to fulfill these desires. The desired ramp locations are given in Table 8. It was concluded that:

1. Standard interchange designs could not always fulfill the desired movement of traffic.
2. The desired movements of traffic could be fulfilled by individual consideration of the desires at each interchange and the placement of the ramps according to these desires.

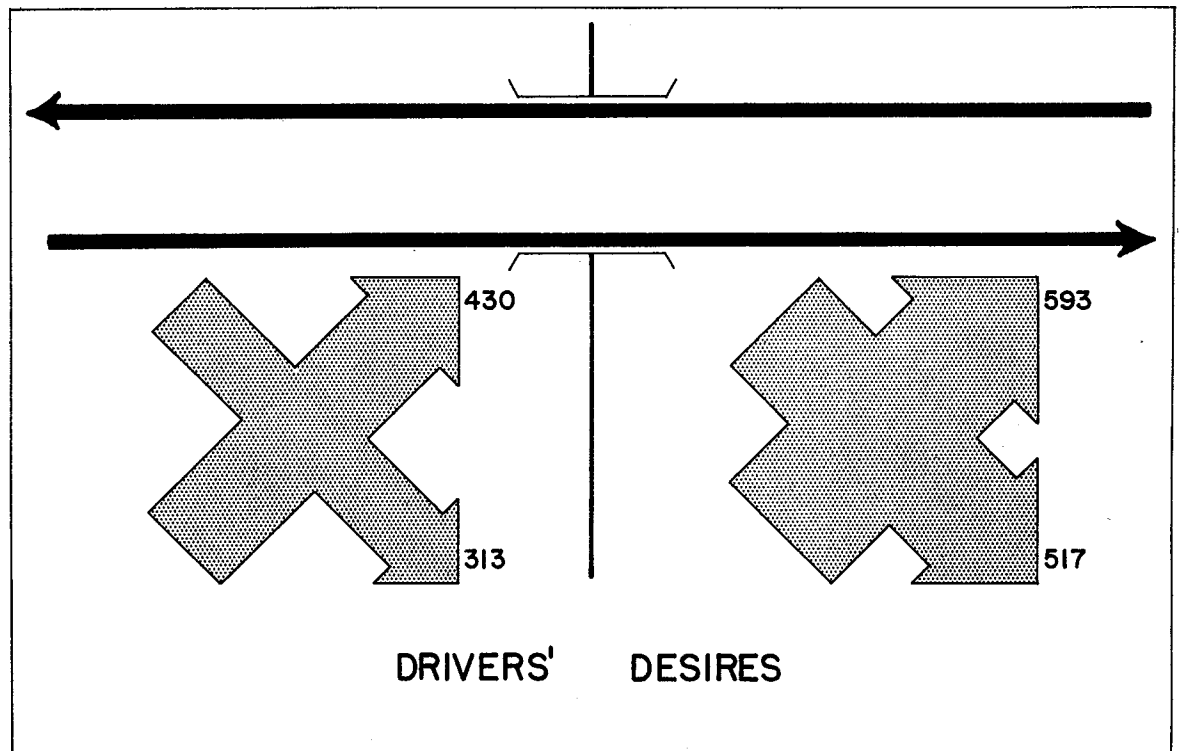
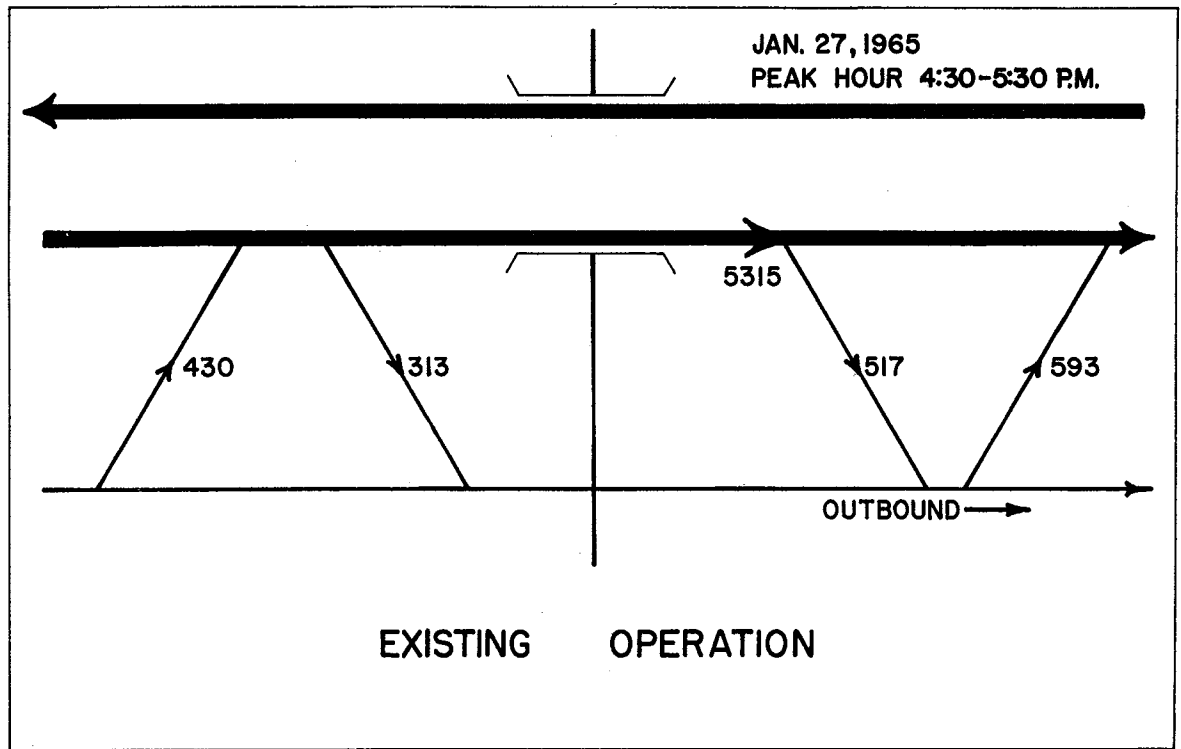

WAYSIDE INTERCHANGE OUTBOUND

FIGURE 37

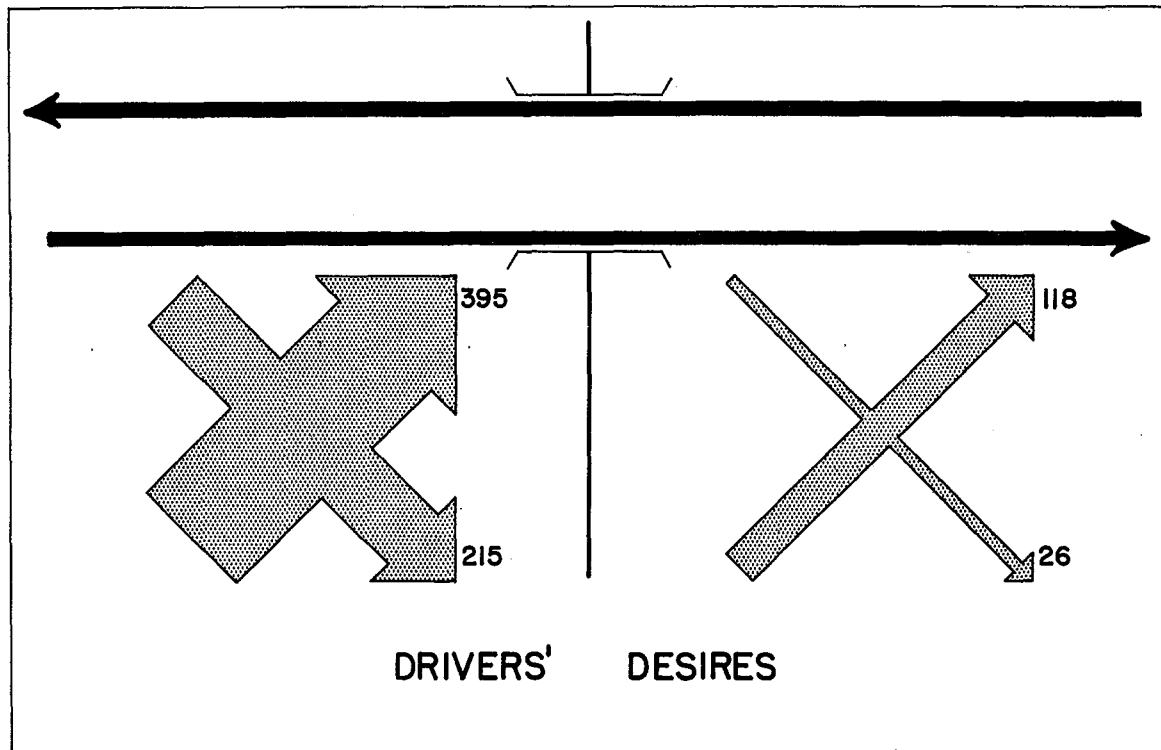
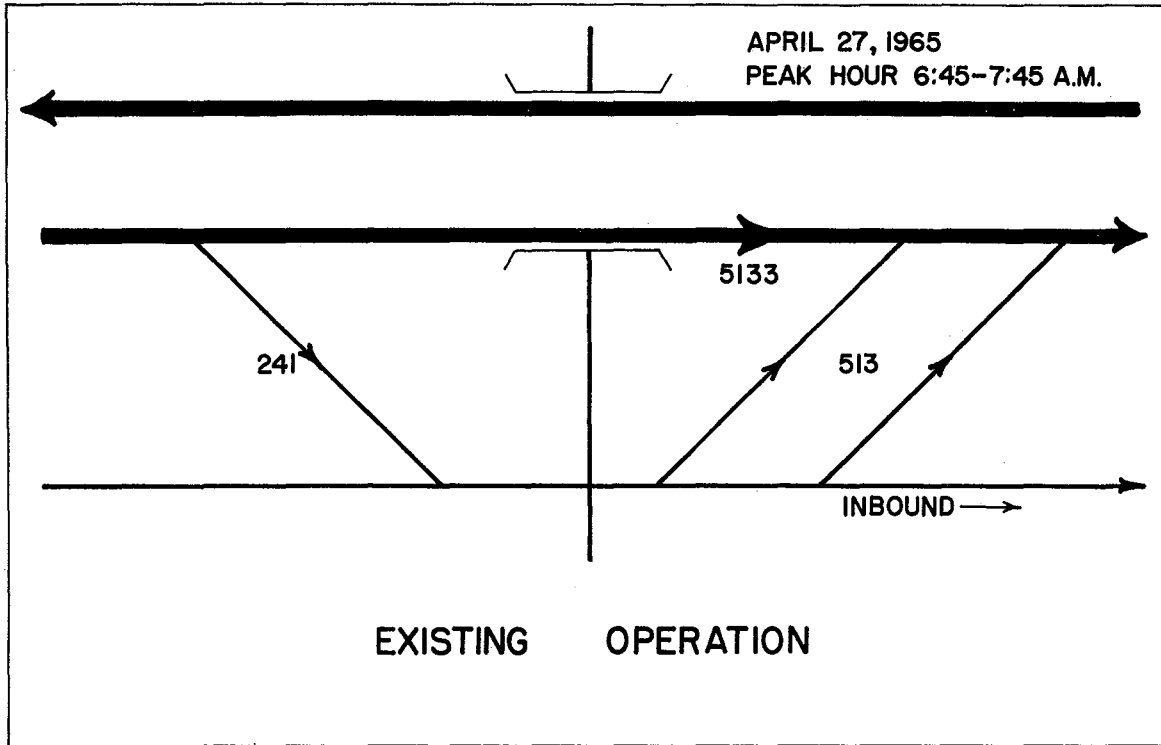

CULLEN INTERCHANGE INBOUND

FIGURE 38



TABLE 8  
DESIRED RAMP LOCATIONS

	Cullen Interchange Outbound	Telephone Interchange Outbound	Woodridge Interchange Outbound	Wayside Interchange Outbound	Cullen Interchange Inbound
An off ramp located down- stream of the arterial street was desired	Yes *	No	Yes *	Yes	No
An off ramp located up- stream of the arterial street was desired	Yes	Yes	Yes	Yes	Yes
An on ramp located up- stream of the arterial street was desired	No	No	No	Yes	Yes *
An on ramp located down- stream of the arterial street was desired	Yes	Yes	Yes	Yes	Yes

\* This ramp was desired, but it does not exist.

# FREEWAY RAMP CONFIGURATION

## Introduction to the Problem

The effect of freeway ramp configuration on the amount of acceptable gap time available to vehicles desiring to enter a freeway at a specific on-ramp was investigated in order to determine the more desirable ramp configuration. In the past, it has been assumed that the greatest amount of acceptable gap time available to vehicles desiring to enter the freeway would be provided by removing off-ramp traffic before allowing on-ramp traffic to enter. This research tested that assumption to determine if it was valid and to evaluate the advantage to freeway operation that might result.

In this research, an acceptable gap was defined as a gap an average driver would accept when entering a freeway. The selection of an acceptable gap time for an average driver was not critical as used in this research because the same basis of comparison was used for each configuration. An average value of three seconds was chosen.

## Theoretical Gap Distributions

To determine the effect of freeway ramp configuration on the amount of acceptable gap time available, theoretical gap distributions were fitted to the observed data. The exponential distribution can be fitted to the observed distribution of gaps for free flowing volumes, but it is unsatisfactory for high volumes because of two conditions which are:

1. Vehicles have length and must follow each other at some minimum headway.
2. Vehicles cannot pass at will even on a freeway.

Gerlough<sup>11</sup> proposed that the first condition be overcome by shifting the exponential curve to the right an amount equal to a certain minimum headway,  $T$ . The probability of a gap greater than  $t$  then becomes

$$P(g > t) = e^{-(t-T)/(\bar{t}-T)}$$

To overcome the second condition, it was proposed by Schuhl<sup>12</sup> that the traffic stream be considered as composed of a combination of free-flowing and constrained vehicles. Haight<sup>13</sup> suggested that gaps less than the minimum headway,  $T$ , be considered improbable, whereas the shifted exponential considered them impossible.

The exponential distribution and its generalizations represent curves which reach their maximum probability at the origin and then decline as  $t$  approaches infinity. Therefore, these distributions imply that the smaller the gap, the more likely it is to occur. This implication is in error, and it was recently proven to be in error by May.<sup>14</sup> Thus, the exponential distribution was not used in this research.

The Pearson Type III and the Erlang distributions were used in this research since they overcome the conditions mentioned above. These distributions are two-parameter generalizations of the exponential distribution. The Pearson Type III and the Erlang distribution frequency functions are determined by multiplying the exponential distribution frequency function by some appropriate power of  $t$ ,<sup>15</sup> which gives

$$f(t) = \frac{t^{a-1}}{(a-1)!} (qa)^a e^{-aqt}$$

The difference between the Pearson Type III and the Erlang distributions was that for the Erlang distribution, the value of "a" was rounded to the nearest integer before it was used in the frequency equation. The two parameters used in this research were the mean and the variance. The mean was used because it influenced the location of the curve, and the variance was used because it influenced the shape of the curve.

Some difficulty was encountered in fitting the theoretical distributions to the observed data. It was found in some instances that neither theoretical distribution (Pearson Type III or Erlang) could be fitted to the data observed in one-second intervals, that the distributions sometimes could be fitted to the same data observed in two-second intervals. This was also noted by Gerlough,<sup>16</sup> who stated, "Some traffic phenomena may be random when observed for an interval of one length but non-random when observed with an interval of a different length."

The Chi-Square test at the 5 per cent level of significance was used to test the hypotheses that the theoretical distributions fitted the observed data.

#### Method of Study

The study procedure used in the investigation of freeway ramp configuration was a test of the hypothesis that the greatest amount of acceptable gap time available to vehicles desiring to enter the freeway was furnished by removing off-ramp traffic before allowing on-ramp traffic to enter. These studies investigated two ramp configurations. They were:

Case 1 - An off-ramp located upstream of an on-ramp.

Case 2 - An on-ramp located upstream of an off-ramp.

these configurations are illustrated in Figure 39.

A comparison of the total amount of acceptable gap time available at a Case 1 and a Case 2 ramp configuration was desired. For such a comparison to be valid, the study conditions at each location must have been approximately the same. Thus the lane 1 (right lane) freeway volume, Point A in Figure 39, and the off-ramp volume, Point B, at a Case 1 configuration must have been approximately equal to the respective volumes at a Case 2 configuration. Up to a 10 per cent difference in the respective volumes was allowed since it was felt that this amount would not significantly alter the results. Using this procedure, the effects of ramps upstream of the study area were minimized.

### Data Collection

Data were collected twice at each study location. Case 1 studies were conducted at the following locations: the Griggs off-ramp and the Wayside on-ramp - outbound, and the Calhoun-Elgin off-ramp and the Dumble on-ramp - inbound. Case 2 studies were conducted at the following locations: the Scott on-ramp and the Cullen off-ramp - outbound and the Tellepsen on-ramp and Telephone off-ramp - outbound. For both cases, the gaps in lane 1 (right lane) of the freeway were measured just upstream of the nose of the entrance ramp. In this manner the total amount of gap time available on the freeway for entering vehicles was determined. The points of data collection for each case are illustrated in Figure 39. A 176-foot speed trap was established between Points D and C to determine the lane 1 speeds during the study. The freeway volume and the lane 1 volume in the direction of travel under study were counted at Point A, upstream of the first ramp for both cases. The off-ramp volume, Point B, and the on-ramp volume, Point E, were counted during the study.

An Esterline-Angus 20-pen recorder was used to record the volume counts, the gap times, and the travel times through the speed trap. A photograph of the recorder is shown in Figure 40. The pens were used as follows:

Pen #1 was used at the beginning of the speed trap at Point D, 176 feet upstream from the nose of the on-ramp, to record when the front bumper of each vehicle in lane 1 passed the beginning of the speed trap.

Pen #2 was used at the nose of the on-ramp, Point C, to record when the front bumper of each vehicle in lane 1 passed the nose of the on-ramp, to end the speed trap, and to measure the gaps in units of time

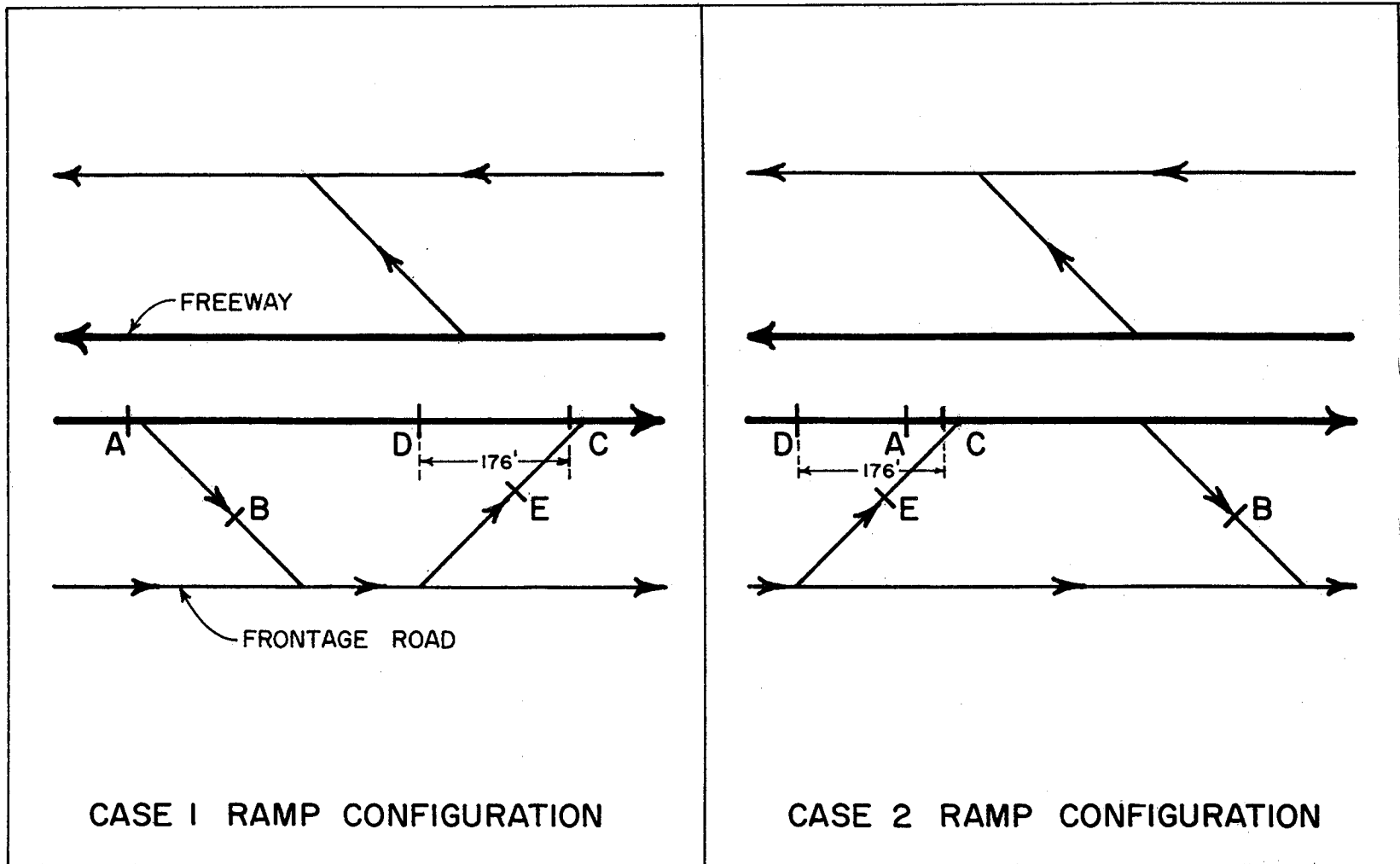

**DATA COLLECTION POINTS**

FIGURE 39

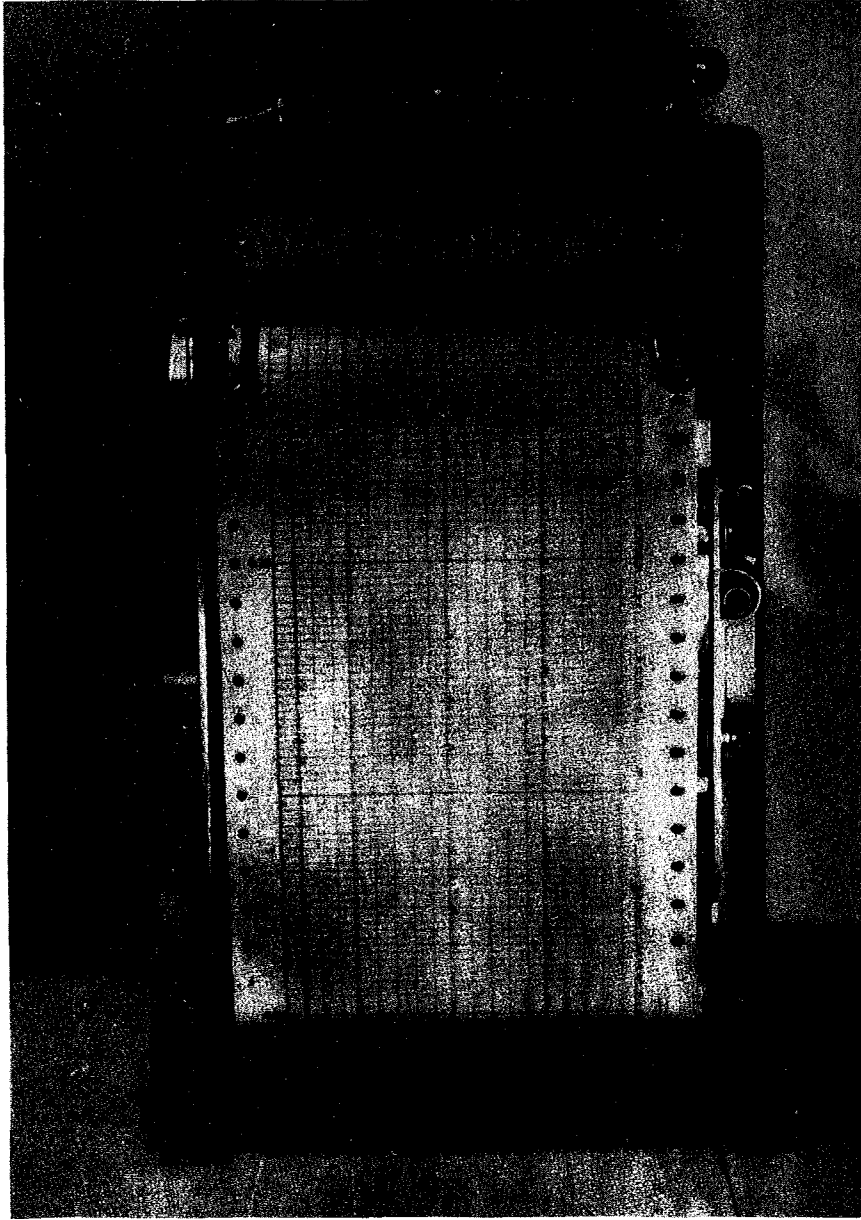

**ESTERLINE - ANGUS 20 PEN RECORDER**

FIGURE 40

between successive vehicles in lane 1.

Pen #5 was used at Point E to record the on-ramp volume.

Pen #10 was used at Point B to record the off-volume.

Pen #15 was used at Point A to record the volume count of lane 1 upstream of the first ramp.

Pen #20 was also used at Point A to record the three-lane freeway volume in the direction of travel under study.

The recorded information was reduced and placed on IBM cards for the data analysis. The freeway gaps were measured to the nearest one-tenth of a second. One IBM card was used for each vehicle. This card contained a vehicle number, a gap time, and a travel time through the speed trap for that vehicle. Each card was also coded with information to identify the study site, date, type of study, length of speed trap, and time of start of the study. The frequency of the gaps is given in Appendix A. The freeway volumes recorded were counted and tabulated in five-minute periods for use in the data analysis.

#### Data Analysis

Periods were selected from the data which could be compared according to the requirements discussed in the Method of Study. Comparisons resulted between data collected at:

1. Scott and Cullen - outbound and Griggs and Wayside - outbound.
2. Tellepsen and Telephone - outbound and Calhoun-Elgin and Dumble-inbound.

Table 9 indicates the validity of these comparisons by providing the lane 1 volume recorded at Point A, the off-ramp volume recorded at Point B, and the respective per cent differences of these values for each comparison.

Using a data observation interval of one second, the Pearson Type III and the Erlang distributions failed to fit the Tellepsen-Telephone and the Calhoun-Elgin and Dumble data. The data observation interval was increased to two seconds, and the Pearson Type III distribution was found to fit both sets of observed data for the 50-minute periods to be compared. The time periods of the data, the interval of the observed data, the value of Chi-Square, the degrees of freedom (d.f.) and the significance of the Chi-Square tests are given in Table 10.

TABLE 9

## COMPARISON OF LANE ONE AND OFF-RAMP VOLUMES

Location	Case	Date	Time Period (P.M.)	Avg 5 Min Off-Ramp Vol	Avg 5 Min Lane One Vol	Freeway Volume	Lane One Avg Speed
Calhoun-Elgin & Dumble-Inbound	1	1/12/65	2:30-3:20	29.2	75.6	250	47.5
Tellespen & Tele- phone-Outbound	2	1/15/65	1:15-2:05	29.7	80.4	266	48.3
				Diff = 2%	Diff = 6%		
Griggs & Wayside- Outbound	1	1/12/65	4:55-5:00	55.0	112.0	419	47.5
Scott & Cullen- Outbound	2	1/13/65	4:10-4:15	53.0	112.0	381	49.0
				Diff = 3%	Diff = 0%		



TABLE 10

## CHI-SQUARE TESTS RESULTS

Study Location	Case	Time Period (P.M.)	Data Interval (Seconds)	Chi-Square Tests Results			
				Pearson Type III	d.f.	Erlang	d.f.
Calhoun-Elgin & Dumble-Inbound	1	2:30-3:20	1	60.54	15	65.91	15
			2	15.88 *	9	19.14	9
Tellepsen & Tele- phone-Outbound	2	1:15-2:05	1	79.66	11	121.72	11
			2	9.86 *	5	22.72	6
Griggs & Wayside- Outbound	1	4:30-5:25	2	26.46	7	69.17	7
			1	55.48	4	49.20	4
			1	12.39	4	12.59	4
			2	8.72	1	5.18	1
			2	3.52 *	2	4.66 *	2
Scott & Cullen- Outbound	2	4:05-5:00	2	25.69	4	60.48	4
			1	15.43	3	32.68	3
			1	14.92	3	12.63	3
			2	4.19	1	5.37	1
			2	3.48 *	1	2.70 *	1

\* Significant at the 5 per cent level

The Pearson Type III and the Erlang distributions, when using a two-second data observation interval, failed to fit the Griggs-Wayside data and the Scott-Cullen data for the 55 minutes of data to be compared. Since these data were collected at a time very close to the afternoon peak period, five-minute periods of data were used so that a change in the traffic characteristics would not occur, making a fit of a distribution to these data impossible. Attempts were made to fit a distribution to two different five-minute periods of data from each location, with a one-second data observation interval. All four of these attempts failed to fit a distribution to the data. The attempts were made again using the same data with two-second data observation intervals. Two of these time periods, which could be compared, were found to follow the Pearson Type III and the Erlang distributions. The Pearson Type III distribution was used in the analysis of results. The information concerning the time periods of the data and the Chi-Square test results are given in Table 10.

### Discussion of Results

The curves of the Pearson Type III distribution which were fitted to the data observed at the Tellepsen-Telephone location (a Case 2 configuration) and the Calhoun-Elgin and Dumble location (a Case 1 configuration) are shown in Figure 41. The total area under each of the curves was equal to one, which is the probability of there being a gap equal to or greater than zero seconds in length. The area under each of the curves to the right of the three-second line, was the probability of an available, acceptable gap at the on-ramp. The probability of an acceptable gap was 0.46 for the Case 2 configuration and 0.68 for the Case 1 configuration. Since the probability of an acceptable gap was the per cent of the gaps which were greater than three seconds, this probability was an excellent indication of the possible ramp capacities. For this comparison, the ratio was 1.49. Therefore, the Case 1 on-ramp could accommodate approximately 1.49 times the capacity of the Case 2 on-ramp.

The curves for the second comparison are shown in Figure 42. The Pearson Type III distribution was fitted to the data collected at the Griggs-Wayside location (a Case 1 configuration) and the Scott-Cullen location (a Case 2 configuration). The probability of an acceptable gap was 0.51 for the Case 1 configuration and 0.30 for the Case 2 configuration. The ratio of these probabilities was 1.70. Therefore, the Case 1 on-ramp could accommodate approximately 1.70 times the capacity of the Case 2 on-ramp.

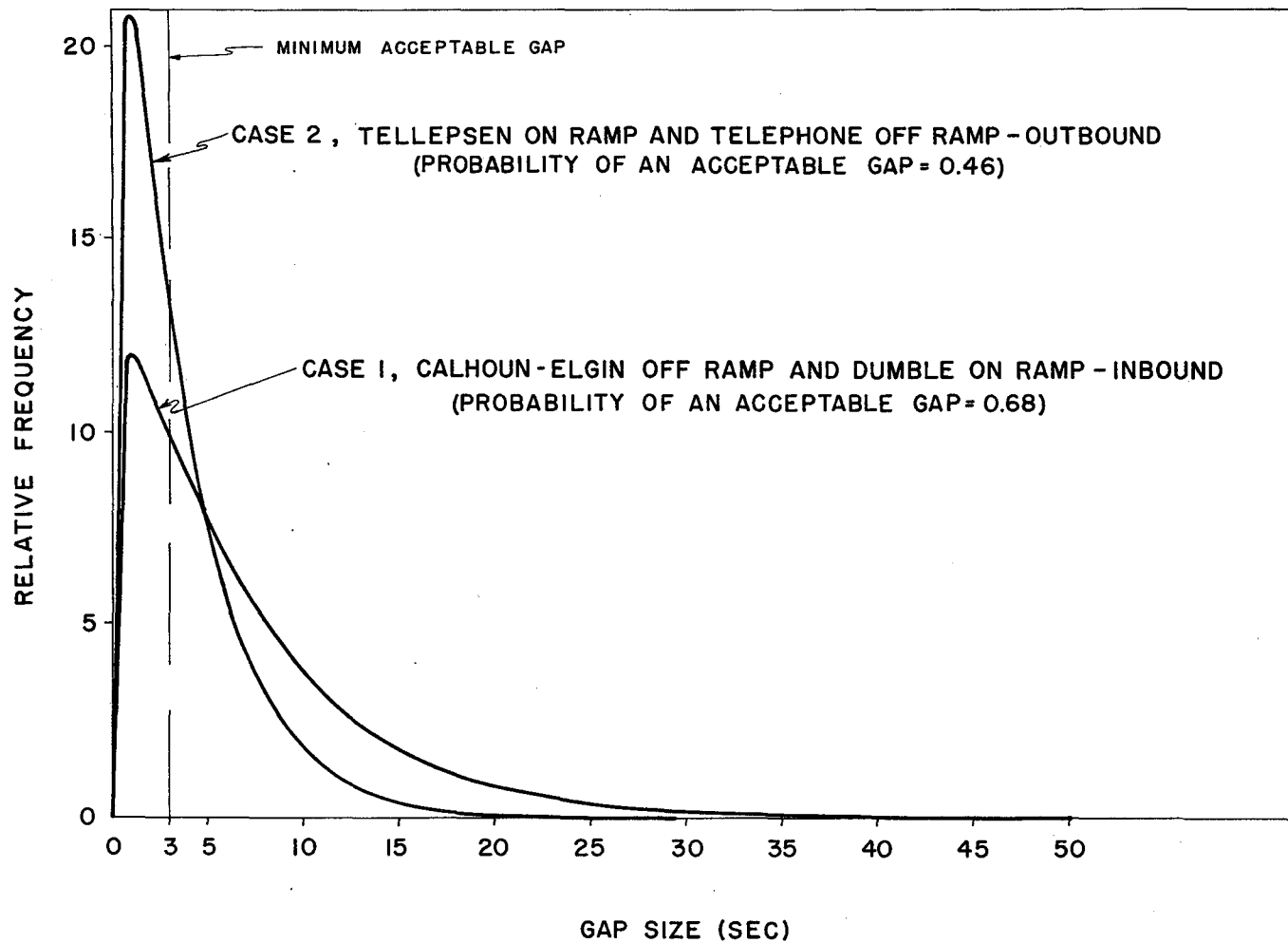

COMPARISON 1 OF ACCEPTABLE GAP PROBABILITY

FIGURE 41

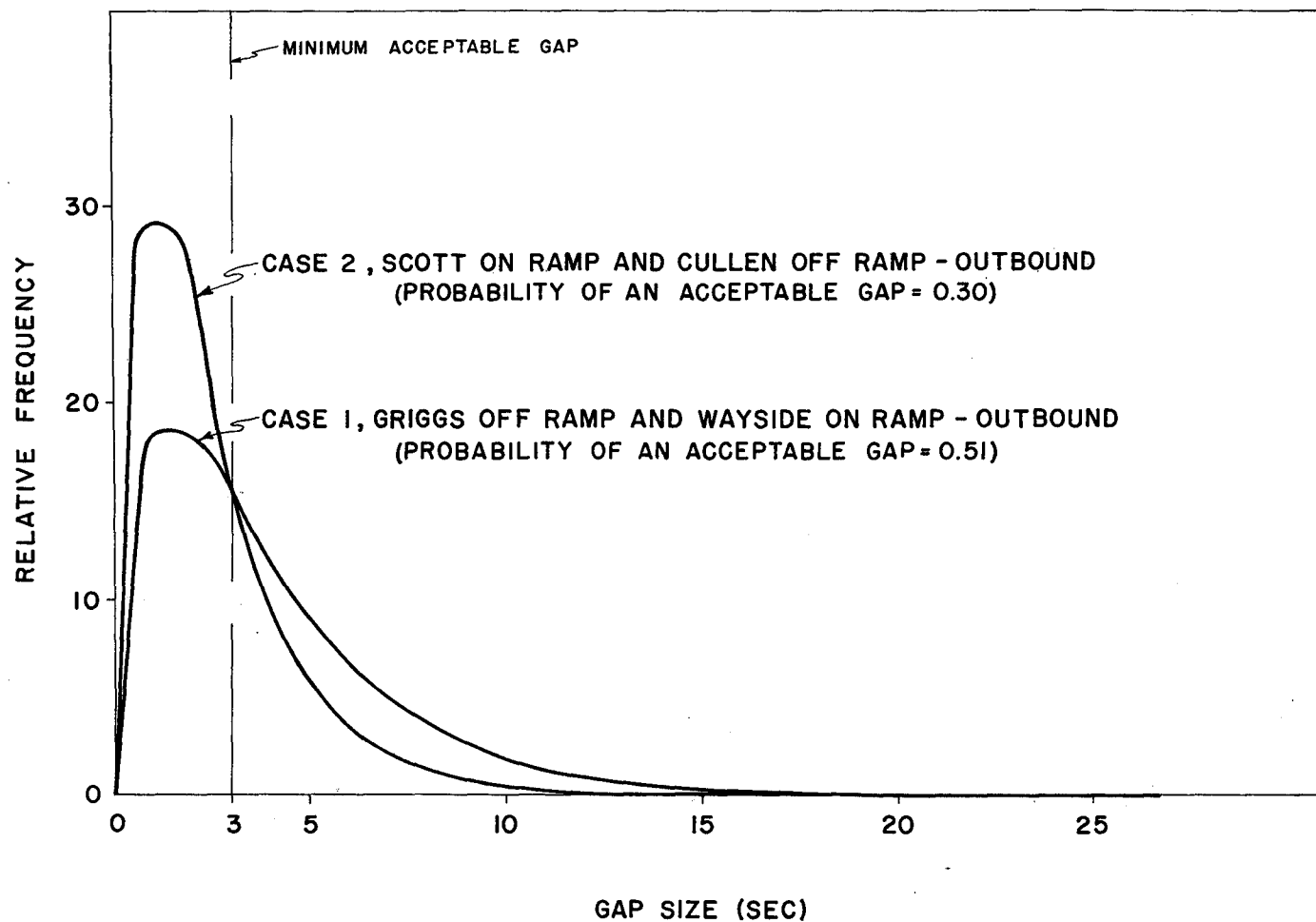

COMPARISON 2 OF ACCEPTABLE GAP PROBABILITY

FIGURE 42

### Conclusion

In the first comparison the Case 1 on-ramp could accommodate approximately 1.49 times the capacity of the Case 2 on-ramp, and in the second comparison the Case 1 on-ramp could accommodate approximately 1.70 times the capacity of the Case 2 on-ramp. Therefore, it was concluded that the Case 1 configuration (an off-ramp upstream of an on-ramp) offers considerable capacity advantages.

## FREEWAY RAMP SPACING

### Introduction to the Problem

The effect on the amount of acceptable gap time as the distance downstream of an off-ramp increased was investigated in an attempt to develop criteria for ramp spacing. It was concluded earlier that the Case 1 configuration (an off-ramp upstream of an on-ramp) was the most desirable. The critical factor in the desired configuration was the distance between the ramps. The ramps in a Case 1 configuration could not be less than certain distance limitations in order to maintain current design standards (to be discussed later), but no limitation has been set on the maximum spacing which could be used without forfeiting the benefit of the greater capacity (greater acceptable gap time) of the Case 1 configuration.

### Method of Study

The study procedure used in this investigation was to determine the probability of acceptable gaps just downstream of an off-ramp and at points located at intervals downstream of the off-ramp (Figure 43). Theoretical distributions were fitted to the observed data so that the probability of acceptable gaps could be determined. Background information and the reasons for choosing the Pearson Type III and the Erlang distributions were previously discussed. The Chi-Square test at the 5 per cent level of significance was used to test the hypotheses that the theoretical distributions fitted the observed data.

### Data Collection

The ramp spacing studies were conducted between the Wayside off-ramp and the Griggs on-ramp - inbound. This location, shown in Figure 43, was called Brays Bayou since the bayou passes through the study section. Both peak and off-peak studies were conducted. The lane 1 gaps were recorded with the 20-pen recorder just downstream of the gore of the Wayside off-ramp and at five points, located every 500 feet downstream of the gore of the off-ramp. The Esterline-Angus 20-pen recorder was used to record the data as follows:

Pen #1 was used just downstream of the gore of the Wayside off-ramp, Point C, to record the lane 1 freeway gaps and to begin the speed trap.

Pen #2 was used at Point D, 176 feet downstream for the end of the speed trap in conjunction with Point C.

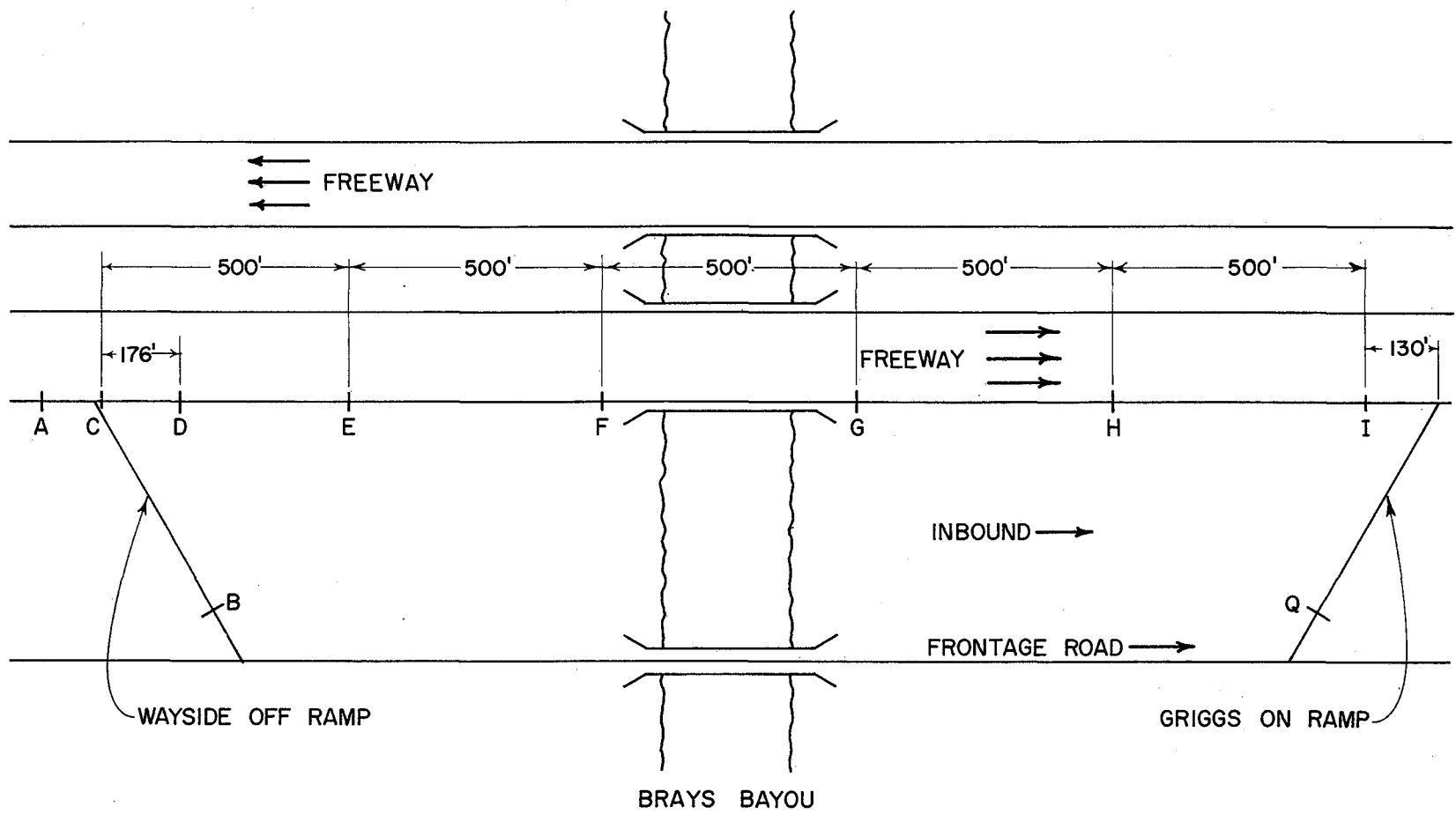

FREIGHTWAY RAMP SPACING STUDY LOCATION

FIGURE 43

Pens #3 through #7 (Points E, F, G, H, and I respectively) were used at the locations downstream of the off-ramp. Pen #3 was used at the Point E, 500 feet downstream of the gore of the Wayside off-ramp, and each pen in turn was located an additional 500 feet downstream.

Pen #15 was used at Point B to record the Wayside off-ramp volume.

Pen #17 was used at Point Q to record the Griggs on-ramp volume.

Pen #20 was used at Point A to record the three-lane freeway volume just upstream of the Wayside off-ramp.

The recorded information was reduced and placed on IBM cards for the data analysis as in the ramp configuration studies. The frequency of the gaps is given in Appendix B.

### Data Analysis

Using a data observation interval of two seconds, the Pearson Type III distribution was found to fit the data observed from 1:30 to 3:00 P.M. (off-peak data) on January 25. The Erlang distribution, for the same data interval, did not fit these observed data for any point. The time period of the data, the data observation interval, the value of Chi-Square, the degrees of freedom (d.f.) and the significance of the Chi-Square tests are given in Table 11. The curves of the Pearson Type III distributions are shown in Figure 44. The area under each of the curves, for gaps of three seconds and greater, was the probability of an available, acceptable gap at the point each curve represents. These probabilities of acceptable gaps being available are tabulated in Table 12.

An attempt was made to fit a theoretical distribution to the data collected from 7:20 to 8:00 A.M. on February 18, using a two-second data observation interval. Both the Pearson Type III and the Erlang distributions failed to fit the observed data (see Table 11). It was decided that the peak-period conditions varied too much during this long time period, and a fit was attempted using the 7:20 to 7:25 A.M. data in one-second data observation intervals. The Erlang distribution fitted these data for four of the five points, and the Pearson Type III distribution fitted these data for three of the five points. The Erlang distribution was used since it fitted more data than did the Pearson Type III distribution. Figure 45 shows the curves of the Erlang distribution. The probability of an acceptable gap being available at each point was determined and tabulated in Table 12.



TABLE 11  
BRAYS BAYOU CHI-SQUARE TESTS RESULTS

Data	Point	On Ramp Closed	Time Period	Data Interval (Seconds)	Chi-Square Tests Results			
					Pearson Type III	d.f.	Erlang	d.f.
Jan 25	C	No	1:30-3:00 P.M.	2	12.99 *	12	46.79	12
	E	No	1:30-3:00 P.M.	2	6.08 *	9	41.91	10
	F	No	1:30-3:00 P.M.	2	12.72 *	9	44.50	8
	G	No	1:30-3:00 P.M.	2	10.75 *	9	42.70	10
	H	No	1:30-3:00 P.M.	2	3.75 *	9	33.00	9
	I	No	1:30-3:00 P.M.	2	15.96 *	10	42.08	11
Feb 16	C	Yes	7:05-7:10 A.M.	2	7.05	1	9.58	1
	F	Yes	7:05-7:10 A.M.	2	9.33	1	8.92	1
	G	Yes	7:05-7:10 A.M.	2	1.27 *	1	2.17 *	1
	H	Yes	7:05-7:10 A.M.	2	3.25 *	1	3.60 *	1
	I	Yes	7:05-7:10 A.M.	2	7.19	1	10.73	1
	C	Yes	7:05-7:10 A.M.	1	23.23	3	32.96	3
	F	Yes	7:05-7:10 A.M.	1	18.28	3	29.19	3
	G	Yes	7:05-7:10 A.M.	1	35.61	3	34.41	3
	H	Yes	7:05-7:10 A.M.	1	14.89	3	13.06	3
	I	Yes	7:05-7:10 A.M.	1	9.78	3	12.37	3

\* Significant at the 5 per cent level

TABLE 11 continued

## BRAYS BAYOU CHI-SQUARE TESTS RESULTS

Date	Point	On Ramp Closed	Time Period	Data Interval (Seconds)	Chi-Square Tests Results			
					Pearson Type III	d.f.	Erlang	d.f.
Feb 18	C	No	7:20-8:00 A.M.	2	32.04	4	12.65	3
	F	No	7:20-8:00 A.M.	2	51.67	3	54.80	3
	G	No	7:20-8:00 A.M.	2	78.12	3	50.48	3
	H	No	7:20-8:00 A.M.	2	72.84	3	86.54	3
	I	No	7:20-8:00 A.M.	2	66.32	3	56.60	3
	C	No	7:20-7:25 A.M.	1	9.72	3	6.82 *	3
	F	No	7:20-7:25 A.M.	1	7.69 *	3	4.45 *	3
	G	No	7:20-7:25 A.M.	1	4.67 *	3	4.51 *	3
	H	No	7:20-7:25 A.M.	1	13.47	3	25.29	3
	I	No	7:20-7:25 A.M.	1	6.03 *	4	5.91 *	4
	C	Yes	7:05-7:10 A.M.	1	7.75 *	3	9.99	3
	F	Yes	7:05-7:10 A.M.	1	25.95	3	27.07	3
	G	Yes	7:05-7:10 A.M.	1	12.14	3	15.21	3
	H	Yes	7:05-7:10 A.M.	1	17.74	3	14.71	3
	I	Yes	7:05-7:10 A.M.	1	14.72	3	15.04	3
	C	Yes	7:05-7:10 A.M.	2	3.54 *	1	3.84 *	1
	F	Yes	7:05-7:10 A.M.	2	1.92 *	1	4.90	1
	G	Yes	7:05-7:10 A.M.	2	5.66	1	6.87	1
	H	Yes	7:05-7:10 A.M.	2	2.16 *	1	2.83 *	1
	I	Yes	7:05-7:10 A.M.	2	3.44 *	1	3.39 *	1

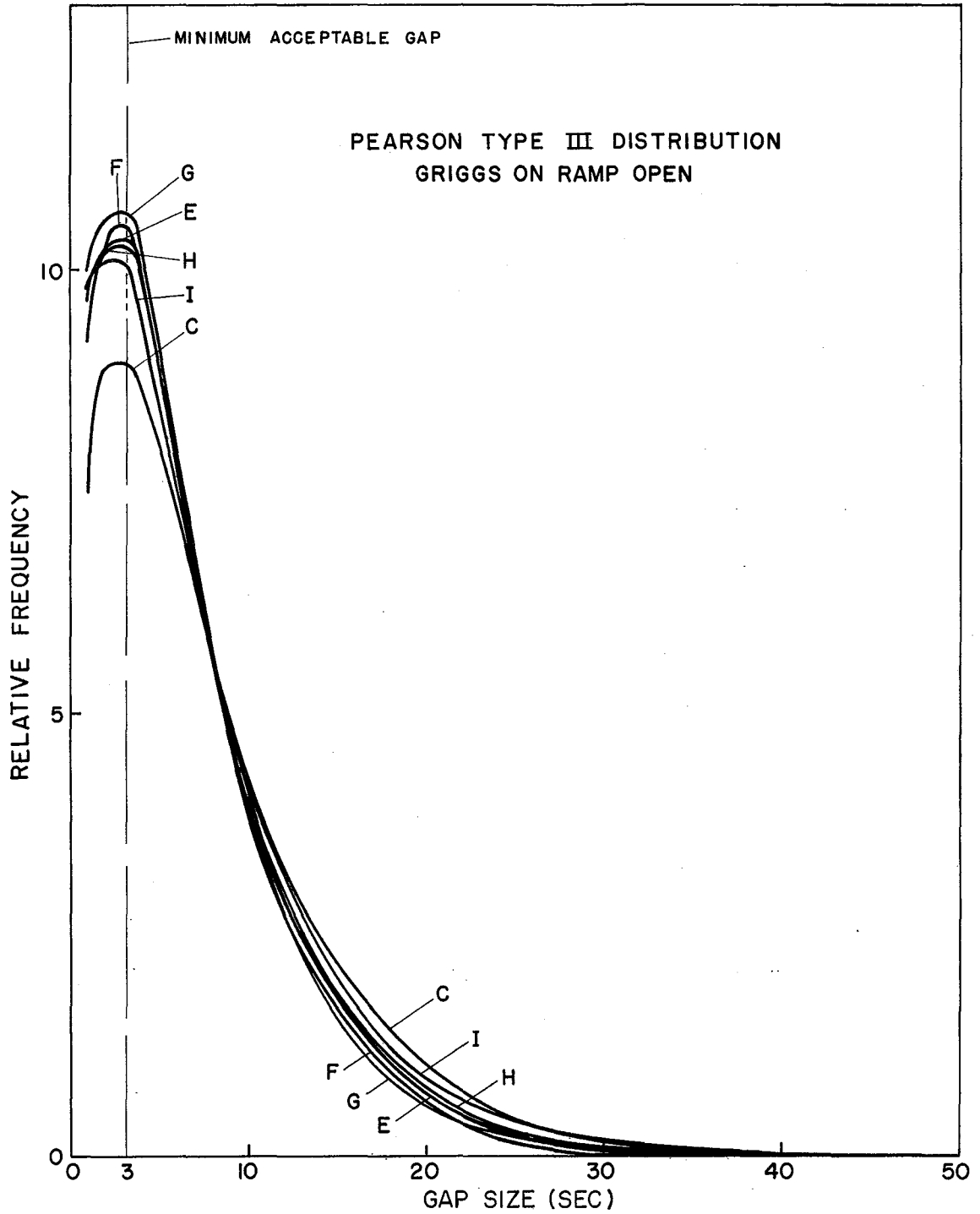

GAP DISTRIBUTIONS, BRAYS BAYOU, 1:30-3:00 PM, JAN 25

FIGURE 44

TABLE 12

## PROBABILITY OF ACCEPTABLE GAPS AT BRAYS BAYOU

Point	1:30-3:00 P.M. Jan. 25, 1965	7:20-7:25 A.M. Feb. 18, 1965	7:05-7:10 A.M. Feb. 18, 1965
C	0.78	0.33	0.33
E	0.74	No Data	No Data
F	0.77	0.34	0.24
G	0.72	0.34	Not Significant
H	0.76	Not Significant	0.22
I	0.74	0.43	0.26

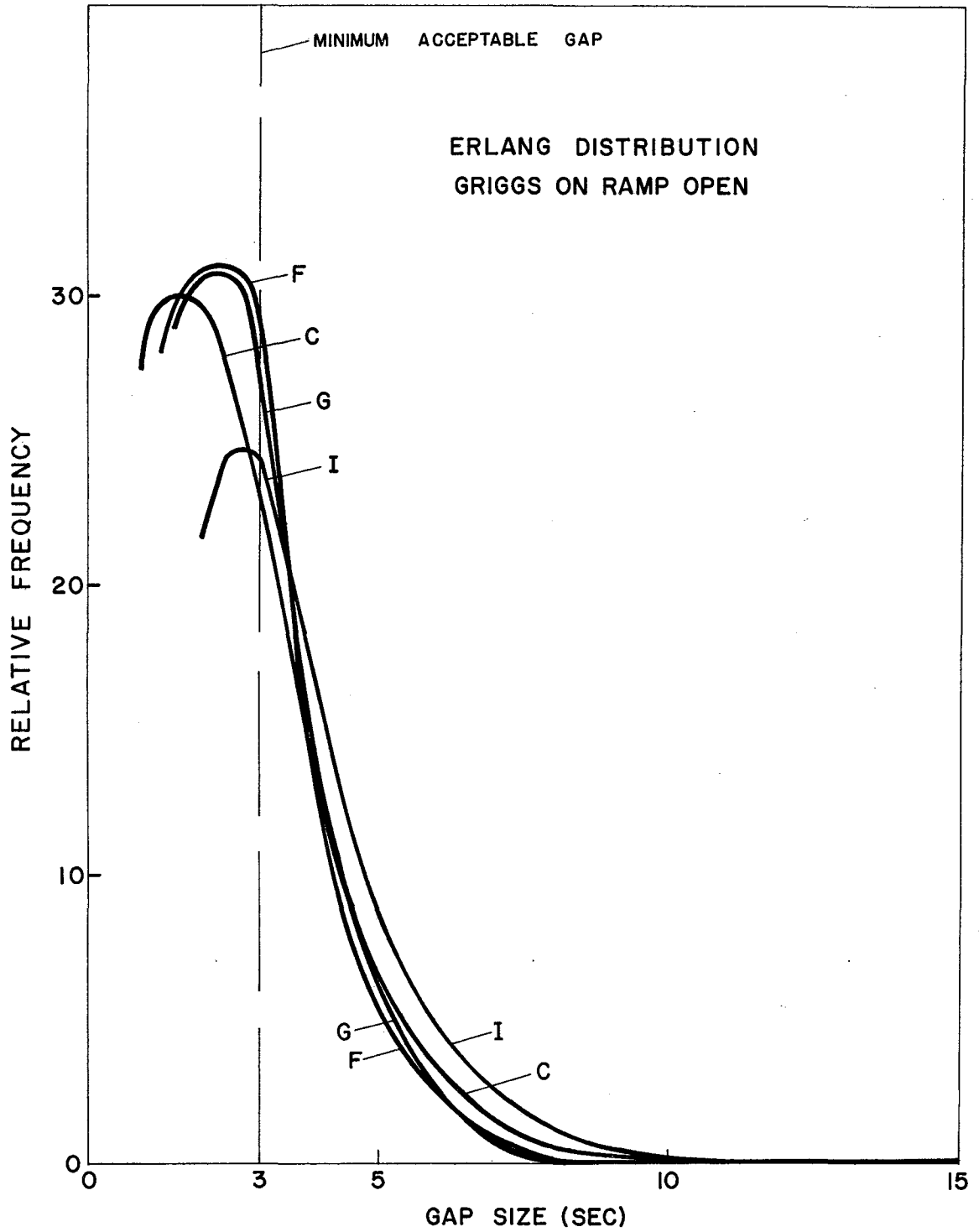

GAP DISTRIBUTIONS, BRAYS BAYOU, 7:20-7:25 AM, FEB 18

FIGURE 45

The results of these data (see Discussion of Results) showed an effect of the Griggs on-ramp (approximately 130 feet downstream of Point I) which made it necessary to study data collected when the on-ramp was closed due to the freeway control study. (As a part of the freeway control study, the Griggs on-ramp was closed for a 15-minute period each weekday morning.) A five-minute period of data, collected from 7:05 to 7:10 A.M. when the Griggs on-ramp was closed, was used in one-second data observation intervals in an attempt to fit a distribution to these data. A fit was obtained for only one point; thus, another attempt was made using two-second data observation intervals. The Pearson Type III distribution fitted the observed data for four of the five points, and the Erlang distribution fitted the observed data for three of the five points. The Pearson Type III distribution was used since it fitted the most data. The curves of the Pearson Type III distribution are shown in Figure 46. The probability of an available, acceptable gap at each point is given in Table 12.

Additional data, collected from 7:05 to 7:10 A.M. on February 16, when the Griggs on-ramp was closed, were analyzed in an attempt to obtain another set of probabilities for peak-period data with the on-ramp closed. These data were used in two-second data intervals in an attempt to fit a distribution to the data. The Erlang and the Pearson Type III distribution fitted these data for the same two of the five points. Since Point C (at the off-ramp) was not one of the locations for which a distribution was fitted to the data, these probabilities could not be used. Thus, one-second data observation intervals were used, and a distribution could not be fitted to any of these data. Hence, none of the data collected on February 16 could be used in the results.

### Discussion of Results

The curves of the probabilities of available, acceptable gaps as related to the distance from the gore of the off-ramp are shown in Figure 47. The highest curve represented the probabilities of the data collected from 1:30 to 3:00 P.M. (off-peak data) on January 25. This curve was essentially a straight line which showed no effect of the distance between the ramps on the probability of available, acceptable gaps.

The center curve represented the probabilities of the data collected from 7:20 to 7:25 A.M. on February 18, when the Griggs on-ramp was open. The curve shows a very slight increase at Points F and G, and a marked increase at Point I. This study would usually have been expected to result in a decrease in the probability of available,

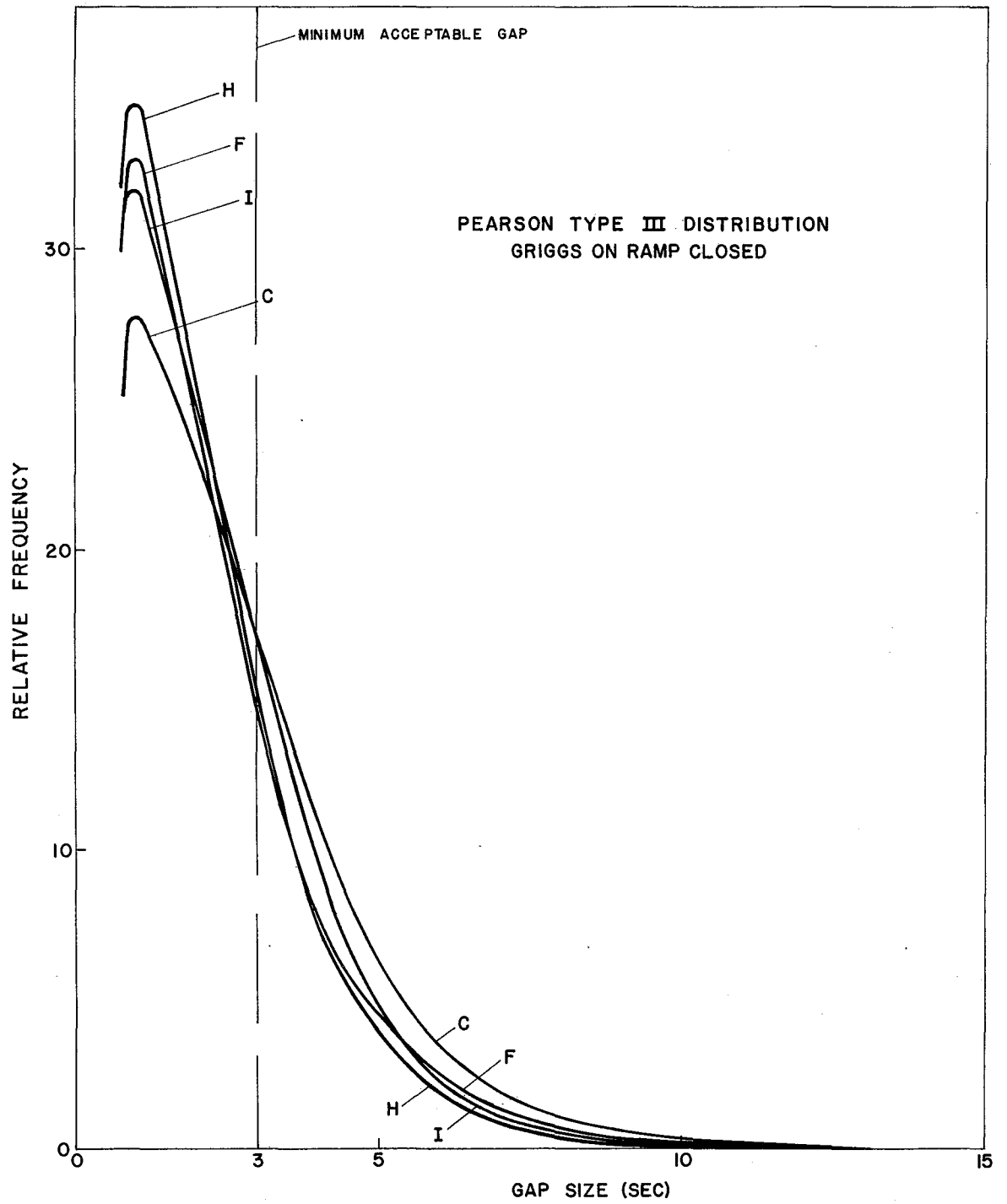

GAP DISTRIBUTIONS, BRAYS BAYOU, 7:05-7:10 AM, FEB 18

FIGURE 46

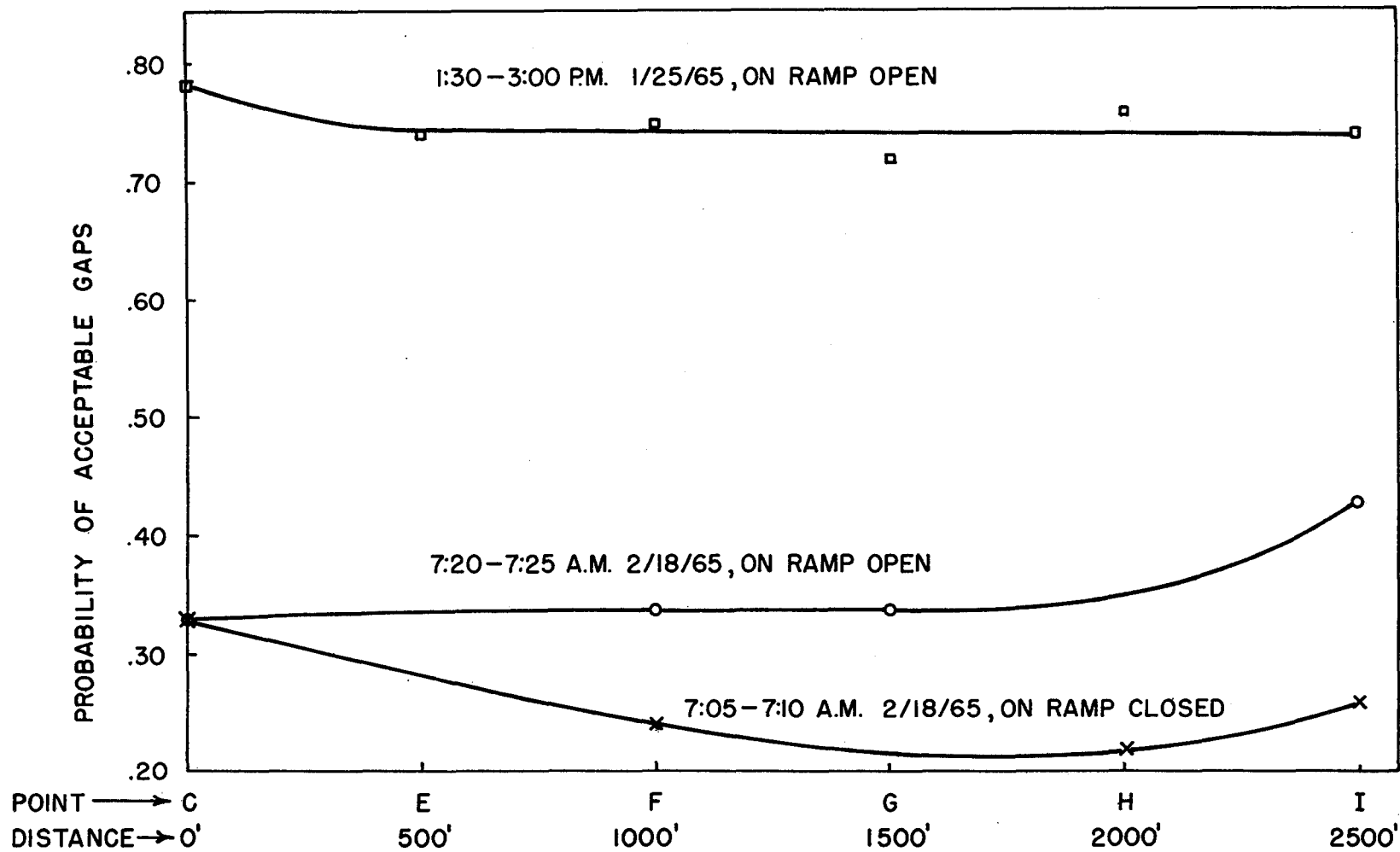

EFFECT OF DISTANCE BETWEEN RAMPS ON ACCEPTABLE GAP PROBABILITY

FIGURE 47



acceptable gaps as the distance between the ramps increased. But, while the data were being collected, it was noted that vehicles were leaving lane 1 for the center lane as they approached the Griggs on-ramp. This was occurring because the drivers in lane 1 had a very good view of the Griggs on-ramp, since it was located at an up-grade, and at 7:20 A.M. they saw vehicles queued on the on-ramp and the frontage road, waiting to enter the freeway. This curve verified the observation that vehicles were leaving lane 1 in the vicinity of the Griggs on-ramp since it shows an increase in the probability of acceptable gaps. Therefore, the decision was made to study data that were collected when the Griggs on-ramp was closed, to eliminate its effect.

The lowest curve represented the probabilities of the data collected from 7:05 to 7:10 A.M. on February 18, when the Griggs on-ramp was closed. This curve showed a decrease in the probability as the distance increased up to Point F as was expected. But, since the probability increases at Point I and possibly at Point H, the remainder of the curve showed that the Griggs on-ramp still had an effect even though it was closed. It was presumed that this effect was caused by repeat drivers, who did not realize that the Griggs on-ramp was closed and left lane 1 to avoid the Griggs on-ramp traffic.

### Conclusion

The peak period studies of the effect on the amount of acceptable gap time as the distance downstream of an off-ramp increased were inconclusive. No peak-period data were available which could be used to develop criteria for ramp spacing due to the failure to eliminate the effect of the Griggs on-ramp even when it was closed to traffic. It was decided that studies must be conducted at a location where no on-ramp exists for a distance substantially greater than 2600 feet downstream of an off-ramp, in order to obtain data suitable for developing criteria for ramp spacing on this basis.

## FEASIBILITY OF STACKED RAMPS

### Introduction to the Problem

Previously discussed results indicated that at several interchanges both an on-ramp and an off-ramp were desired at the same location (upstream or downstream of the arterial street), and it was concluded that a Case 1 configuration (an off-ramp upstream of an on-ramp) was the most desirable configuration. These results could be satisfied by an off-ramp located upstream of an on-ramp and by stacked ramps (a modification of an off-ramp upstream of an on-ramp with grade separated ramps). In this section the results of an investigation of the feasibility of stacked ramps is presented.

### Method of Study

Stacked ramps and an off-ramp located upstream of an on-ramp were designed to evaluate their relative costs, the right-of-way required, weaving, and the potential for stage construction.

For the design of the stacked ramps the following factors were assumed:

1. The facility was a six-lane freeway which had an inside shoulder on each side of the median and an outside shoulder.
2. The centerline of the freeway and the frontage road were at the same elevation.

For the design of the stacked ramps the following criteria were used:

1. The Texas Highway Department recommended designs were used for the ramps.<sup>17</sup>
2. The on-ramp horizontal and vertical curves<sup>18</sup> were designed for 40 miles per hour.
3. The off-ramp vertical curves were designed for 35 miles per hour.<sup>18</sup>

In this design one lane of the frontage road was dropped as the freeway on-ramp left the frontage road in order to obtain maximum usage of the available right-of-way. A lane was added to the frontage road as the freeway off-ramp joined the frontage road. In this design the on-ramp

crossed over the off-ramp. A 90-foot bridge span was required to cross the off-ramp and provide adequate side clearance. The vertical distance from pavement to pavement at the ramp crossing was 18 feet. Due to the limited right-of-way in this design, columns were required rather than earth to support the on-ramp grades, and retaining walls were required for the off-ramp depression. This design provided 875 feet between the two ramps (from the physical off-ramp gore to the on-ramp nose as in Figure 48). The right-of-way requirement for this design was 360 feet for a minimum distance of 2325 feet along the freeway.

For the normal design of an off-ramp upstream of an on-ramp the following factor was assumed in addition to those assumed for the stacked ramp design:

1. The combined volume of the two ramps during the peak hour was 1250 vehicles per hour or 625 vehicles per hour per ramp.

The criteria used for this design were:

1. The Texas Highway Department recommended designs were used for the ramps.<sup>17</sup>
2. The weaving distance on the frontage road was designed for volumes of 1250 vehicles per hour to operate at a speed of 35 miles per hour.<sup>17</sup>

In this design a 50-foot outer separation was adequate to provide a 350-foot deceleration lane. A weaving distance of 500 feet was provided on the frontage road between the two ramps to accommodate 1250 weaving vehicles per hour at an operating speed of 35 miles per hour. The plan profile of this design is shown in Figure 49. This design provided 1335 feet between the two ramps. The right-of-way requirement for this design was 268 feet for a distance of 2785 feet along the freeway.

#### Discussion of Results

The results of the designs indicated that the stacked ramp design required 360 feet of right-of-way and a distance of 2325 feet along the freeway, and the off-ramp located upstream of an on-ramp design required 268 feet of right-of-way and a distance of 2785 feet along the freeway. These respective designs are shown in Figures 48 and 49. The stacked ramp design required 460 feet less along the freeway than does the alternate design.

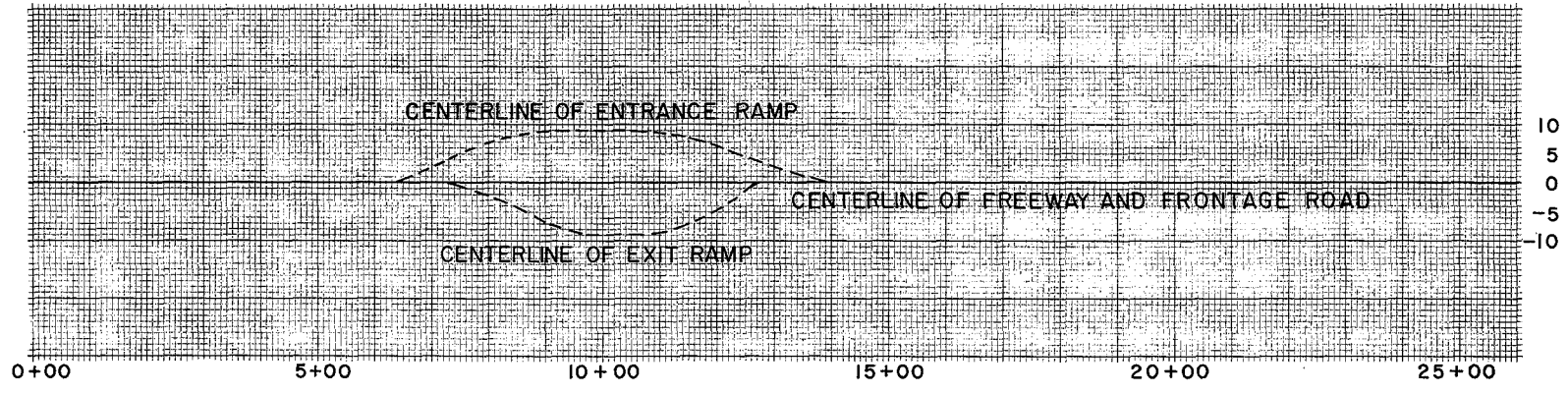
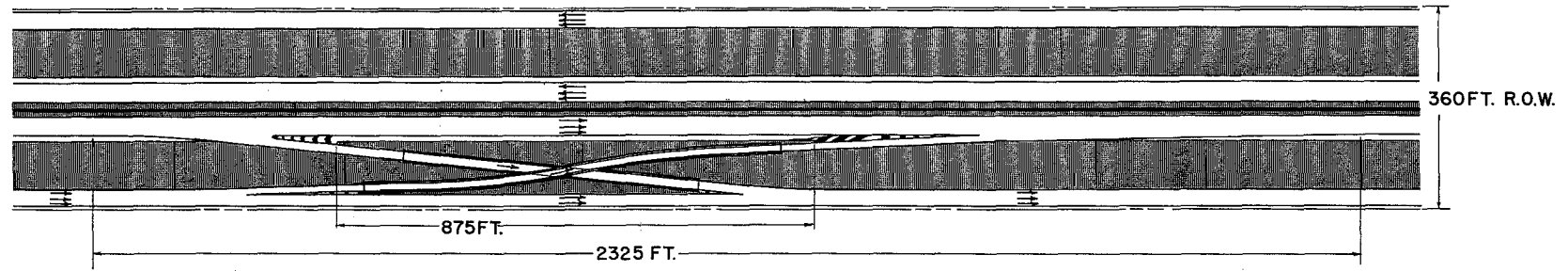

PLAN PROFILE OF STACKED RAMPS

FIGURE 48

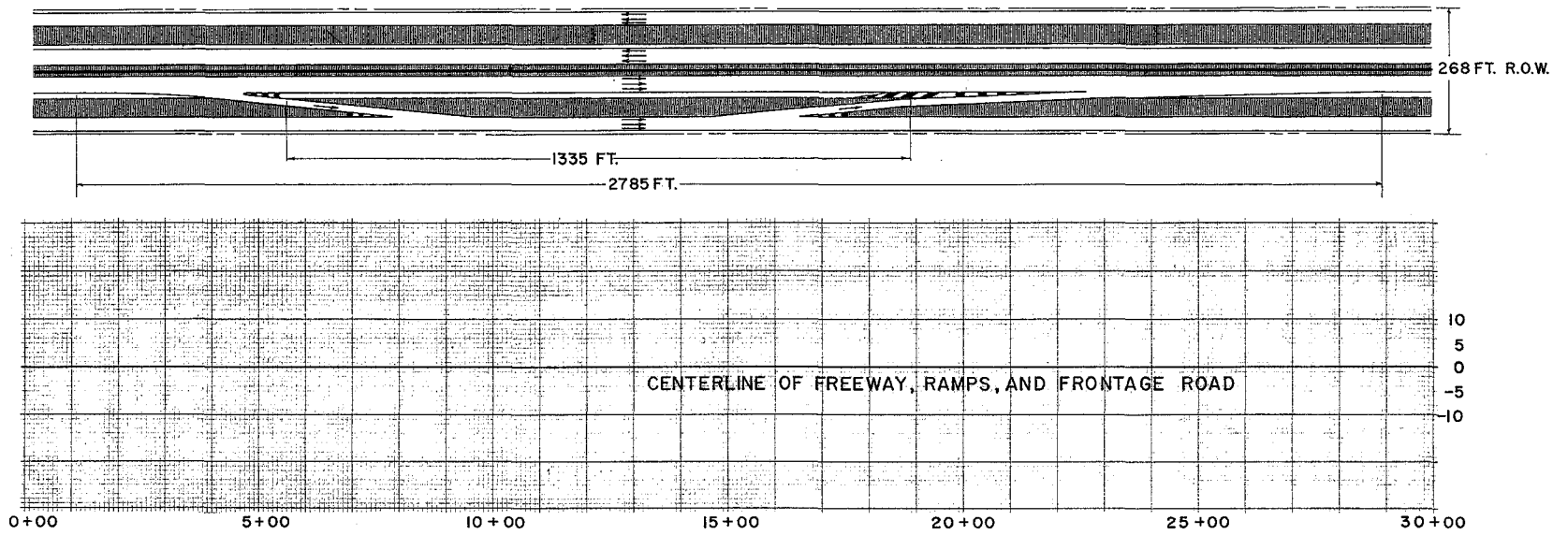

PLAN PROFILE OF AN OFF RAMP UPSTREAM OF AN ON RAMP

FIGURE 49

The estimated cost of the stacked ramp design would have been many times greater than the cost of the alternate design due to the additional right-of-way required, the bridge required to raise and lower the on-ramp, the 90-foot span to cross over the off-ramp, and the retaining walls required in the off-ramp depression.

Weaving would be completely eliminated from the frontage road in the stacked ramp design since the vehicles cross paths at a grade separation. The off-ramp located upstream of an on-ramp configuration could create weaving problems on the frontage road. This weaving could be accommodated by an adequately designed weaving distance without too much distance being required, due to the relatively low operating speed on the frontage road. (A weaving volume of 1250 vehicles per hour can be accommodated at an operating speed of 35 miles per hour in a distance of 500 feet.)<sup>17</sup>

The off-ramp located upstream of an on-ramp configuration had the potential for stage construction since adding the second ramp would not physically affect the first ramp constructed. Stage construction would be considered in the original design so that the first ramp would be located so as to furnish the distance along the freeway required by the addition of another ramp. The stacked ramp configuration did not have great potential for stage construction because the existing ramp would have to be reconstructed to cross the ramp to be added, additional right-of-way would be required, and the frontage road would have to be moved to increase the width of the outer separation.

### Conclusion

The high cost, the lack of potential for stage construction, and the additional right-of-way required, indicates that the construction of stacked ramps may not be generally feasible to gain the advantages of no weaving on the frontage road and less distance (460 feet) required along the freeway to fit in the design. The stacked ramp arrangement could be expected to provide a high level of service, however, and in many cases might warrant consideration.

## INTERCHANGE LAYOUTS

### Introduction to the Problem

The suitability of various interchange layouts in fulfilling drivers' desires, providing access to freeway and arterial street traffic, and reducing the interference to freeway and arterial street traffic was investigated to determine the merits of two proposed types of interchange layouts. Each of the types of interchange layouts investigated were formed on the basis of the results discussed earlier in this report.

### Method of Study

The types of interchange layouts considered are shown in Figure 50. The ramps in the layouts were shown as dashed lines to indicate the location of the ramps if they were desired. One of the previous conclusions stated that the desired movement of traffic could be fulfilled by providing ramps based on these desires. Therefore, each of the interchange layouts which were investigated had the potential to fulfill drivers' desires. A Case 1 configuration (an off-ramp located upstream of an on-ramp) which was concluded to be the most desirable ramp configuration was used twice in the Type 1 layout and once in the Type 2 layout. The Type 1 layout had a Case 1 configuration upstream and downstream of the arterial street, and the Type 2 layout had a Case 1 configuration spanning the arterial street. The Case 1 configurations in each layout were an off-ramp located upstream of an on-ramp since it was concluded that the use of stacked ramps may not be feasible in all cases.

The types of interchange layouts were compared using the following considerations:

1. Potential for stage construction.
2. Fulfillment of drivers' desires.
3. Critical distance (off-ramp to arterial street).
4. Maximum access to abutting property.
5. Maximum access to the freeway.
6. Freeway with reduced capacity at interchange.
7. Freeway without reduced capacity at interchange.

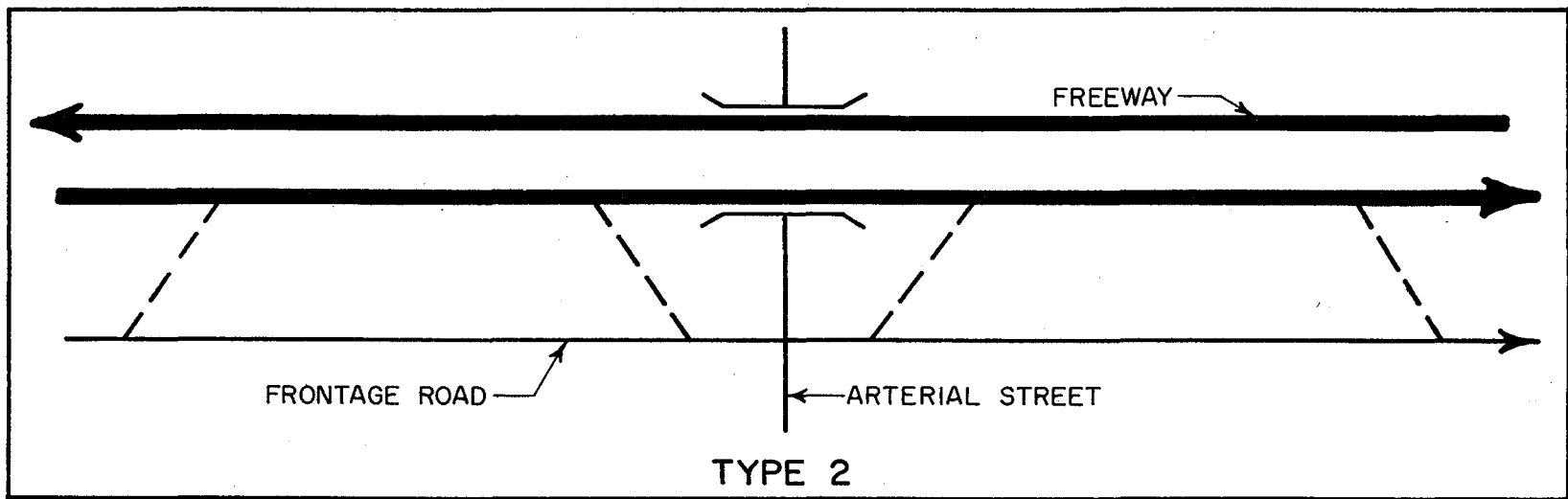
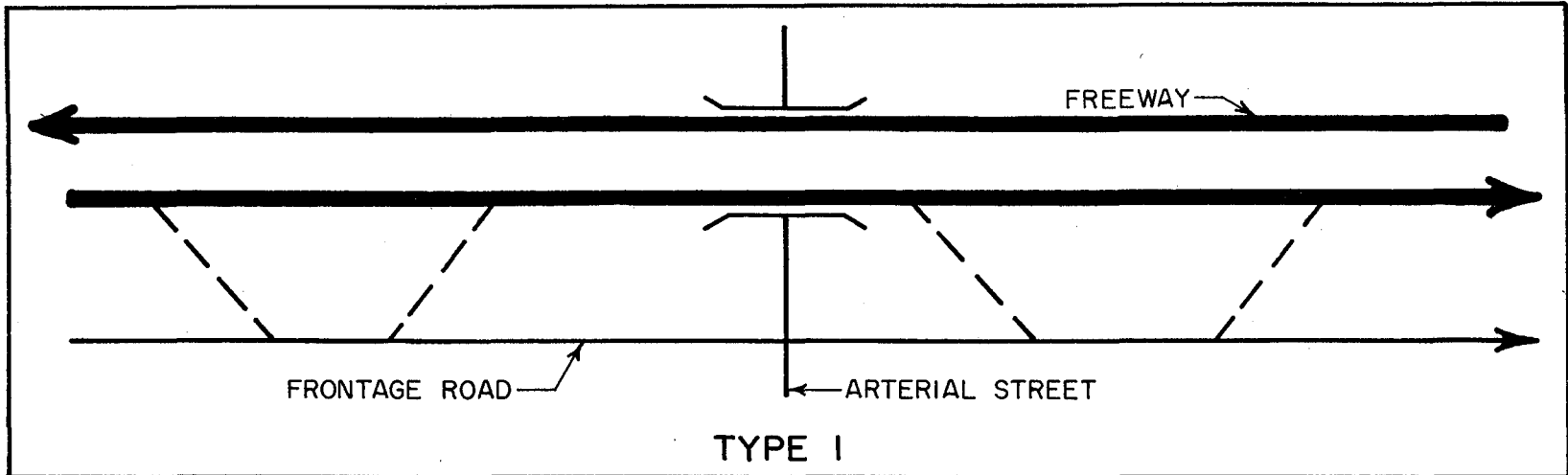

**TYPES OF INTERCHANGE LAYOUTS**

FIGURE 50



8. Minimum interference to the arterial street.
9. Weaving on the freeway.
10. Interstate signing standards.

### Discussion of Results

In Figure 50 the ramps are shown as dashed lines to indicate the location of the respective ramps if they were desired. All of the ramps should be included in the original design, but only the desired ramps would be built in the original construction. Therefore, if a ramp were not desired at the time the interchange was constructed, adequate space would be provided in the interchange layout for the stage construction of the other ramps which might be desired at some future date. Each of the types of interchange layouts provide for the potential of stage construction of ramps.

In the Type 2 interchange layout, a critical distance between the terminal of the off-ramp located upstream of the arterial street, and the arterial street was introduced. This distance needed to be sufficient to provide an adequate storage space for vehicles stopped for the signal in addition to an adequate weaving distance in which the off-ramp traffic could weave across the frontage road to make a right turn at a signal. This distance was dependent on the frontage road volume, the signalized intersection capacity for this approach, the number of frontage road lanes, and the number of off-ramp vehicles desiring to make a right turn.

Maximum access to abutting property was provided by locating an off-ramp just downstream of an arterial street. And, an on-ramp located just upstream of an arterial street maximized direct access to the freeway, from abutting property, and minimized the volume of traffic required to cross straight through the intersection to gain access to the freeway. The Type 1 interchange layout provided for ramps to be located in this manner, and therefore, it furnished the maximum access to both the freeway and abutting property (Figure 51).

Minimum interference to the arterial street traffic was provided by locating an on-ramp just upstream of the arterial street. This ramp reduced the volume on the frontage road approach to the signalized intersection by the number of vehicles that desire to enter the freeway. Thus, a minimum effect was felt by the arterial street, and a greater portion of the "green time" at the signalized intersection could be used for the movement of arterial street traffic. The Type 1 interchange layout provided an on-ramp at this location, and hence, it furnished minimum interference to the arterial street (Figure 51).

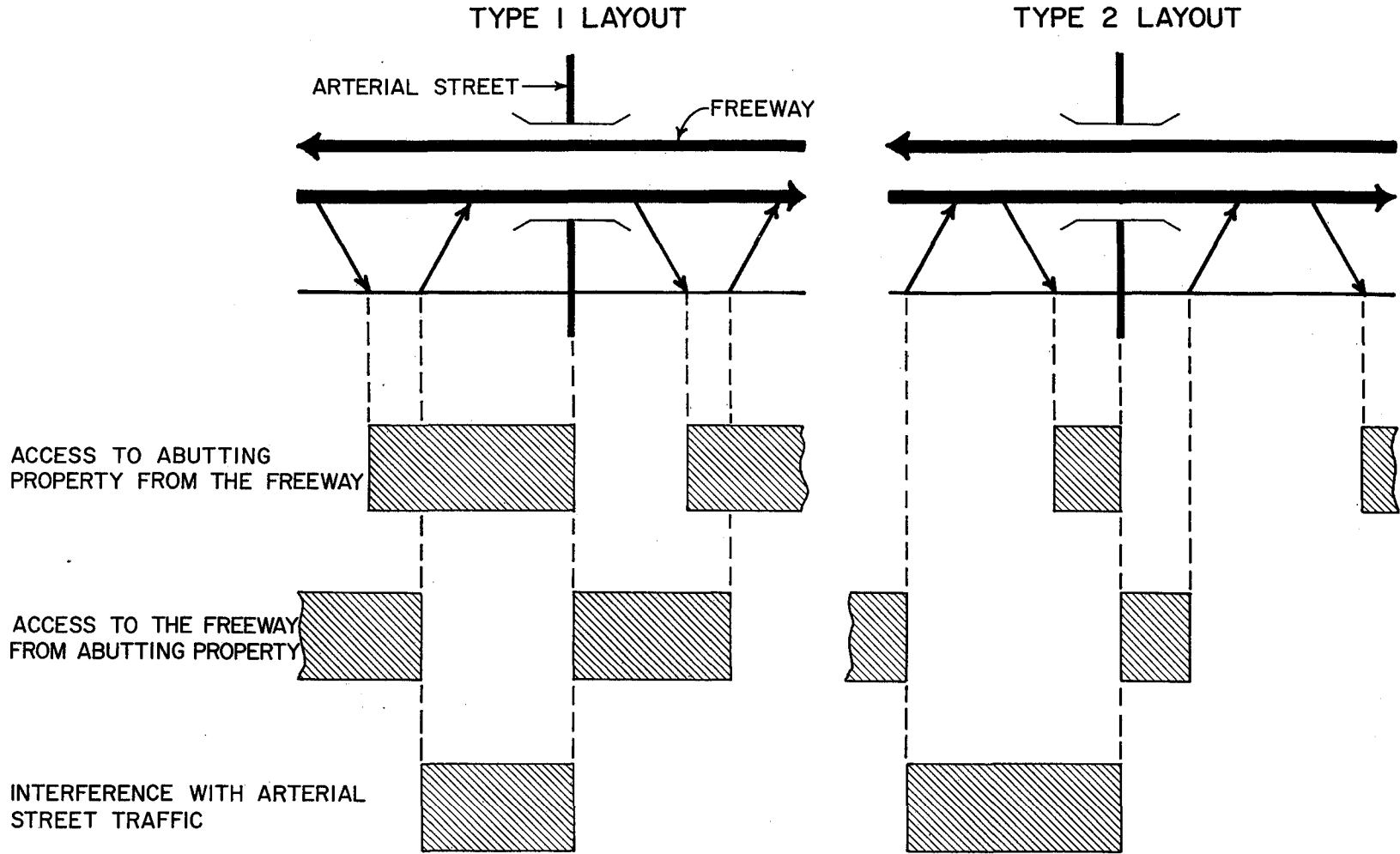

SOME EFFECTS OF INTERCHANGE LAYOUTS

FIGURE 51

Minimum interference to the freeway was determined by the design as the freeway and the arterial street crossed. If the design was such that the capacity of the freeway was reduced (for example by introducing a sharp increase in freeway grade) as it crossed the arterial street, the Type 2 interchange layout should be used. In this instance the freeway volume would have been reduced as the capacity of the freeway was reduced. If the capacity of the freeway was not reduced by the design, either type of interchange layout could be used with minimum interference to the freeway.

Freeway signing, following Interstate Highway standards, could be used for either type of interchange layout, since the distance between interchange layouts approached one mile as a minimum.

### Conclusions

Considering the factors discussed above, the Type 1 interchange layout was the better layout with one exception. This exception was that the Type 2 interchange layout would be required when the capacity of the freeway was reduced as the freeway crossed the arterial street. A comparison of the types of interchange layouts as related to the factors discussed is shown in Table 13.

TABLE 13

## COMPARISON OF TYPES OF INTERCHANGE LAYOUTS

Factors	Type of Interchange Layout	
	Type 1	Type 2
Potential for Stage Construction:	X	X
Fulfillment of Driver's desires:	X	X
Critical Distance (off-ramp to arterial street):		X
Maximum Access to Abutting Property:	X	
Maximum Access to the Freeway:	X	
Freeway with Reduced Capacity at Interchange:		X
Freeway without Reduced Capacity at Interchange:	X	X
Minimum Interference to the Arterial Street:	X	
Weaving on the Freeway:	X	X
Meets Interstate Signing Standards:	X	X

## FREEWAY LAYOUTS

### Interchange Spacing

The minimum spacing of interchanges was investigated since the freeway designer is usually faced with the task of designing a new facility which can service existing arterial streets that are often closely spaced. The two types of interchange layouts discussed in the previous section were considered to investigate the interchange spacing that would result from their use.

### Method of Study

Two types of freeway layouts were determined. They were:

1. Type I, which resulted from combining two of the Type 1 interchange layouts (Figure 50) closely together, and
2. Type II, which resulted from combining two of the Type 2 interchange layouts (Figure 50) closely together to form a section of freeway.

To develop the Type I freeway layout using a pair of Type 1 interchange layouts, the following were assumed:

1. All ramp volumes were 625 vehicles per hour,
2. The freeway volume between an on-ramp and an off-ramp was 5400 vehicles per hour, and
3. The freeway did not have a reduction in capacity as it crossed the arterial street.

The design of an off-ramp upstream of an on-ramp as described earlier was used in the freeway layout.

Moskowitz and Newman's procedure<sup>6</sup> was used to determine the distance required between the physical nose of an on-ramp and the physical gore of a downstream off-ramp. This calculation is given in Appendix C.

A special case of the Type I freeway layout was determined by overlapping the two pairs of ramps between the arterial streets in the Type I freeway layout. Thus, in the special case of the Type I freeway layout there were only two ramps between the arterial street.

The Type II freeway layout using a pair of Type 2 interchange layouts was made assuming the same values as were assumed for the Type I freeway layout. This freeway layout used the same ramp designs as the off-ramp upstream of an on-ramp, but the spacing on the frontage road between the ramps was different due to the signalized intersection within this area. A special case of the Type II interchange layout was determined by overlapping the two pairs of ramps in the Type II freeway layout.

### Discussion of Results

The Type I freeway layout and its special case (overlapping the two pairs of ramps between the arterial streets) are shown in Figure 52. The minimum interchange spacing resulting from combining two Type I interchange layouts was 5670 feet, or just over one mile.

The minimum interchange spacing for the special case of the Type I freeway layout was one half of the previous distance, 2835 feet, or just over 0.5 mile. One disadvantage of the special case is that the short interchange spacing may create signing problems.

The Type II freeway layout and its special case are shown in Figure 53. The minimum interchange spacing resulting from combining two of the Type 2 interchange layouts was 5170 feet plus two different weaving distances and a vehicle storage distance. The weaving distance #1 is dependent on the off-ramp traffic which desires to turn right at the signal, and the frontage road volume. The storage distance is dependent on the frontage road volume, the "green time" for the frontage approach, and the number of approach lanes on the frontage road. The weaving distance #2 is dependent on the number of drivers desiring to enter the freeway who made right turns onto the frontage road, and the existence of a free right turn which might enter the frontage road at a point some distance downstream of the intersection.

The minimum spacing of the special case of the Type II freeway layout would be somewhat greater than one half of the Type II freeway layout minimum interchange spacing. This occurred because it was certain that the sum of the three unknown distances would be greater than the 500 feet between the two ramps in the center of the Type II freeway layout. Signing problems may also occur for this short interchange spacing.

### Conclusion

Minimum interchange spacing was provided by the Type I freeway layout which consisted of the combination of two interchange layouts with an off-ramp located upstream of an on-ramp both before and after an arterial street (Type I interchange layout). This gives additional emphasis to the durability of the Type I interchange layout.

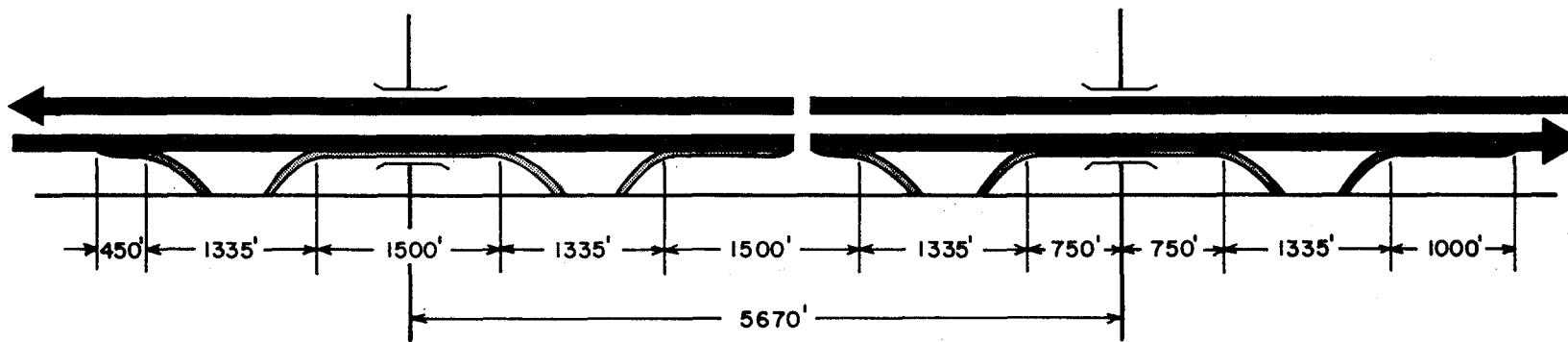

**TYPE I FREEWAY LAYOUT**  
(MINIMUM SPACING DESIGN)

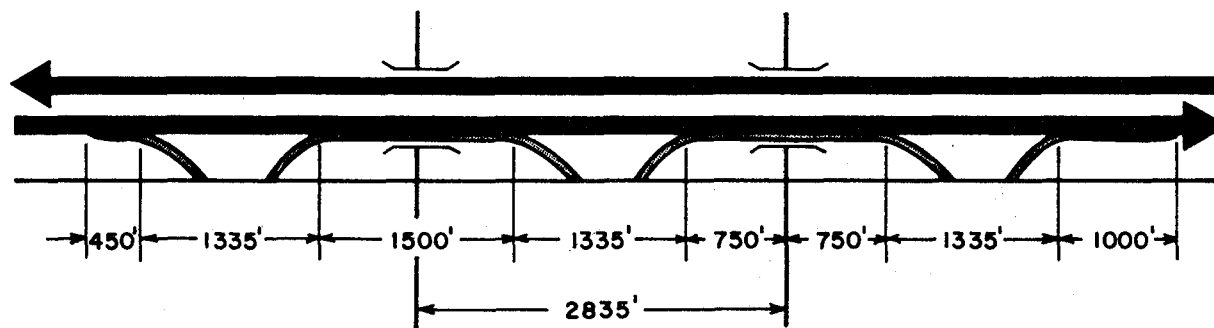

**SPECIAL CASE OF A TYPE I FREEWAY LAYOUT**  
(MINIMUM SPACING DESIGN)

**TYPE I FREEWAY LAYOUTS**

FIGURE 52

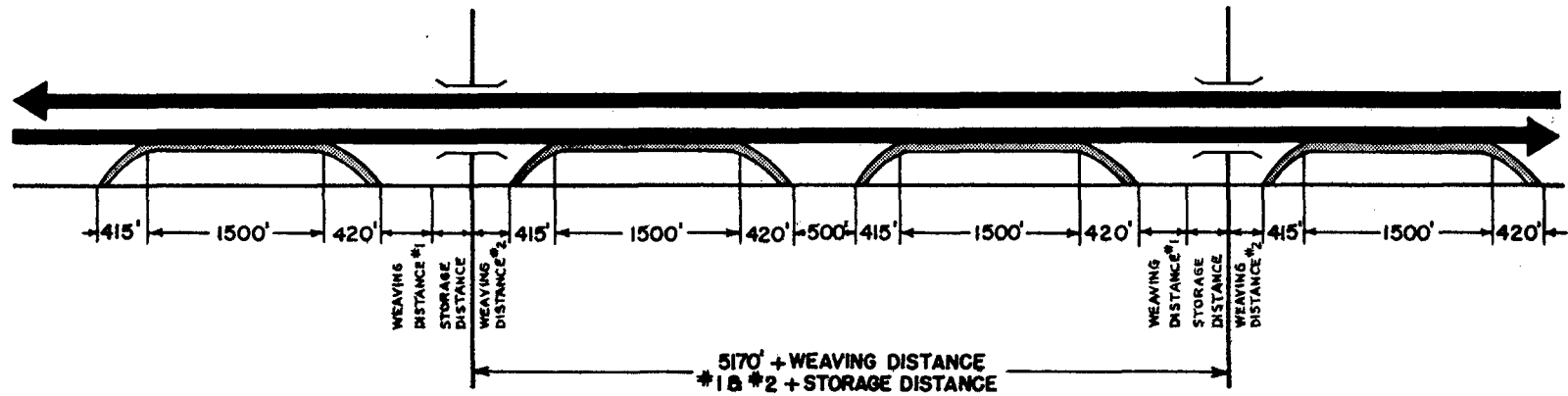

**TYPE II FREEWAY LAYOUT**  
(MINIMUM SPACING DESIGN)

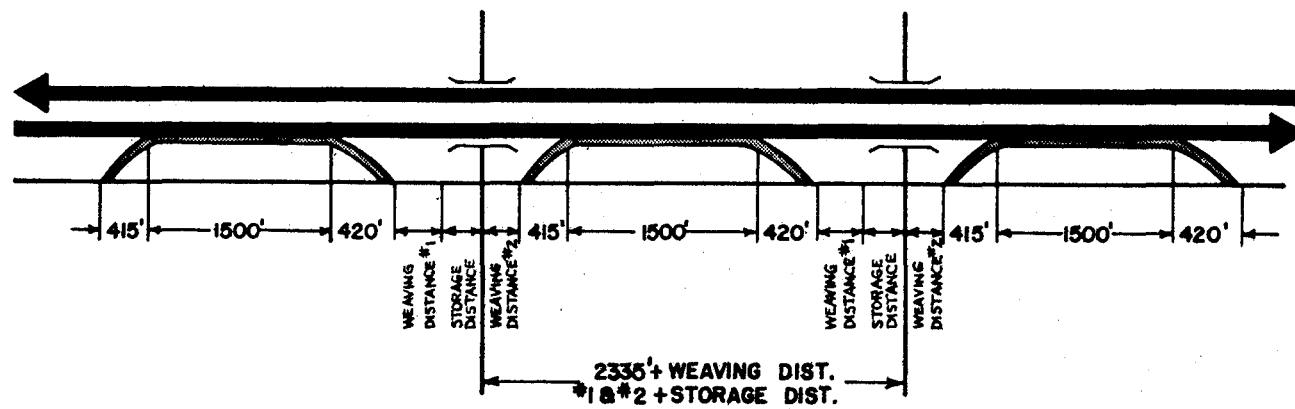

**SPECIAL CASE OF A TYPE II FREEWAY LAYOUT**  
(MINIMUM SPACING DESIGN)

**TYPE II FREEWAY LAYOUTS**

FIGURE 53



## CONCLUSIONS

From the investigations of factors affecting the design location of freeway ramps the following conclusions were drawn:

1. Standard interchange designs cannot always fulfill the various desired movements at different interchanges. To obtain the most efficient operation at a specific interchange, it may be desirable to use a diamond type, an x-type, or possibly a combination of both of these. Considerable effort should be made to predict the desired movements at any given interchange and to design the ramp arrangements accordingly.
2. The configuration of an off-ramp located upstream of an on-ramp has considerable advantages over the reverse configuration. The studies indicated that an approximate 50 to 70% increase in on-ramp capacity could be obtained by removing traffic in advance of adding traffic to the freeway.
3. The construction of stacked ramps rather than an off-ramp upstream of an on-ramp was not generally feasible due to the high probable cost, the lack of potential for stage construction and the additional right-of-way required. The stacked ramps however offer the advantages of elimination of weaving on the frontage road and less distance (approximately 460 feet) required along the freeway to fit in the design. The desirability of the stacked ramp use would have to be evaluated in each specific case considering the topography, the need for this type ramp as indicated by traffic volumes, and other individual factors.
4. With one exception, the type of interchange layout which has an off-ramp located upstream of an on-ramp both upstream and downstream of the arterial street is the most desirable. The exception would exist when the freeway capacity is reduced by the design as the freeway crosses the arterial street. On the basis of this study, it appears that considerable attention should be given to the use of an x-type interchange which would provide the desired interchange layout.
5. Minimum interchange spacing was provided by the combination of two interchange layouts with an off-ramp located upstream of an on-ramp both before and after an arterial street (type 1 interchange layout). This gives additional emphasis to the desirability of the type 1 interchange layout.

## BIBLIOGRAPHY

1. Keese, C. J., Pinnell, C., and McCasland, W. R. "A Study of Freeway Traffic Operation," Highway Research Board Bulletin 235, 1960, pp. 73-132.
2. Pinnell, C. and Keese, C. J. "Freeway Ramps," Report by Texas Transportation Institute, 1960.
3. Fukutome, I. and Moskowitz, K. "Traffic Behavior and On-Ramp Design," Highway Research Board Bulletin 235, 1960 pp. 35-72.
4. Hess, Joseph W. "Capacities and Characteristics of Ramp-Free way Connectors," Highway Research Board Record Number 27, 1963, pp. 69-115.
5. Fisher, R. L. "Accident and Operating Experience at Interchanges," Highway Research Board Bulletin 291, 1961, pp. 124-138.
6. Moskowitz, K. and Newman, L. "Notes on Freeway Capacity," Highway Research Record Number 27, pp. 44-68.
7. Conklin, Robert D. "A Comparison of Vehicle Operating Characteristics between Parallel Lane and Direct Taper Types of Freeway Off Ramps," Proceedings Institute of Traffic Engineers, 1959, pp. 19-20.
8. Fukutome, I. and Moskowitz, K. "Traffic Behavior and Off-Ramp Design," Highway Research Record Number 21, 1963, pp. 17-31.
9. Jouzy, N. C. and Michsel, J. L. "Use and Design of Acceleration and Deceleration Lanes in Indiana," Highway Research Record Number 9, 1963, pp. 25-51.
10. Lipscomb, John, "The Effect of Ramps on the Lateral Distribution of Vehicles on a Six Lane Freeway," Thesis, Texas A&M University, 1962.
11. Gerlough, D. L. "Traffic Inputs for Simulation on a Digital Computer," Proceedings of Highway Research Board, Vol. 38, 1959, pp. 480-492.
12. Schuhl, Andre. "The Probability Theory Applied to the Distribution of Vehicles on Two-Lane Highways," Poisson and Traffic, The Eno Foundation, 1955, pp. 59-72.

13. Haight, Frank A. Mathematical Theories of Traffic Flow, Academic Press, New York, 1963.
14. May, Adolf D. "Gap Availability Studies," Highway Research Board Record 72, 1965, pp. 101-136.
15. Drew, Donald R. "A Study of Freeway Traffic Congestion," A Dissertation for Doctor of Philosophy Degree, Submitted to the Graduate College of Texas A&M University, May, 1964.
16. Gerlough, D. L. "Use of Poisson Distribution in Highway Traffic," Poisson and Traffic, the Eno Foundation, 1955, p. 17.
17. Design Manual for Controlled Access Highways, Texas Highway Department, 1960, as revised September 1963.
18. A Policy on Geometric Design of Rural Highways, American Association of State Highway Officials, 1964, pp. 395-398.

APPENDIX A

FREQUENCY OF GAPS-FREEWAY RAMP CONFIGURATION STUDIES

Gap Size (Seconds)	Tellepsen On-Ramp 1:15-2:05 P.M.	Dumble On-Ramp 2:30-3:20 P.M.	Scott On-Ramp 4:10-4:15 P.M.	Wayside On-Ramp 4:55-5:00 P.M.
0 - 2	300	99	61	29
2 - 4	243	113	33	21
4 - 6	125	58	8	15
6 - 8	66	42	7	6
8 - 10	32	37	3	6
10 - 12	16	26	0	2
12 - 14	9	26	0	2
14 - 16	5	15	0	0
16 - 18	2	17	0	0
18 - 20	3	8	0	0
20 - 22	0	6	0	0
22 - 24	0	3	0	0
24 - 26	2	0	0	0
26 - 28	0	2	0	0
28 - 30	0	4	0	0
30 - 32	1	0	0	0
32 - 34	0	0	0	0
34 - 36	0	2	0	0
36 - 38	0	0	0	0
38 - 40	0	0	0	0
40 - 42	0	0	0	0
42 - 44	0	0	0	0
44 - 46	0	0	0	0
46 - 48	0	1	0	0
48 - 50	0	0	0	0

APPENDIX B

FREQUENCY OF GAPS-FREEWAY RAMP SPACING STUDIES

Brays Bayou, Jan. 25, 1:30-3:00 P.M. On Ramp Open

Gap Size (Sec.)	C	E	F	G	H	I
0 - 2	91	133	132	144	133	126
2 - 4	122	148	171	175	161	170
4 - 6	91	121	126	130	128	122
6 - 8	88	92	81	89	87	81
8 - 10	55	75	71	63	73	69
10 - 12	57	53	51	56	54	49
12 - 14	28	44	46	43	47	41
14 - 16	35	24	34	22	27	26
16 - 18	21	16	19	25	17	18
18 - 20	10	17	13	12	16	9
20 - 22	11	9	7	6	8	6
22 - 24	11	4	4	5	6	12
24 - 26	11	3	3	4	3	5
26 - 28	4	0	0	1	5	2
28 - 30	2	4	2	1	1	2
30 - 32	0	0	1	1	1	2
32 - 34	2	1	1	1	2	1
34 - 36	1	0	1	1	0	1
36 - 38	2	0	0	0	0	1
38 - 40	0	0	0	0	0	0
40 - 42	0	0	0	0	0	0
42 - 44	0	0	0	0	0	0
44 - 46	0	0	0	0	0	0
46 - 48	0	1	0	0	0	0
48 - 50	0	0	0	0	0	0

APPENDIX B continued

FREQUENCY OF GAPS-FREEWAY RAMP SPACING STUDIES

Brays Bayou, Feb. 16, 7:05-7:10 A.M., On Ramp Closed

Gap Size (Sec.)	C	F	G	H	I
0 - 1	4	10	8	6	4
1 - 2	22	56	62	51	50
2 - 3	19	38	28	30	36
3 - 4	10	13	10	12	18
4 - 5	11	4	7	8	5
5 - 6	2	2	4	7	4
6 - 7	2	2	3	1	1
7 - 8	1	0	1	1	1
8 - 9	0	1	0	0	1
9 - 10	2	2	0	1	0
10 - 11	0	0	0	0	0
11 - 12	1	0	0	0	0
12 - 13	0	0	0	0	0
13 - 14	1	0	1	0	0
14 - 15	0	0	0	0	0
15 - 16	0	0	0	0	0
16 - 17	1	0	0	0	0
17 - 18	0	0	0	0	0
18 - 19	1	0	0	0	0
19 - 20	0	0	0	0	0
20 - 21	0	0	0	0	0
21 - 22	0	0	0	0	0
22 - 23	0	0	0	0	0
23 - 24	0	0	0	0	0
24 - 25	0	0	0	0	0

APPENDIX B continued

FREQUENCY OF GAPS-FREEWAY RAMP SPACING STUDIES

Brays Bayou, Feb. 16, 7:05-7:10 A.M., On Ramp Closed

Gap Size (Sec.)	C	F	G	H	I
0 - 2	26	66	70	57	54
2 - 4	29	51	38	42	54
4 - 6	13	6	11	15	9
6 - 8	3	2	4	2	2
8 - 10	2	3	0	1	1
10 - 12	1	0	0	0	0
12 - 14	1	0	1	0	0
14 - 16	0	0	0	0	0
16 - 18	1	0	0	0	0
18 - 20	1	0	0	0	0
20 - 22	0	0	0	0	0
22 - 24	0	0	0	0	0
24 - 26	0	0	0	0	0
26 - 28	0	0	0	0	0
28 - 30	0	0	0	0	0
30 - 32	0	0	0	0	0
32 - 34	0	0	0	0	0
34 - 36	0	0	0	0	0
36 - 38	0	0	0	0	0
38 - 40	0	0	0	0	0
40 - 42	0	0	0	0	0
42 - 44	0	0	0	0	0
44 - 46	0	0	0	0	0
46 - 48	0	0	0	0	0
48 - 50	0	0	0	0	0

APPENDIX B continued

FREQUENCY OF GAPS-FREEWAY RAMP SPACING STUDIES

Brays Bayou, Feb. 18, 7:05-7:10 A.M., On Ramp Closed

Gap Size (Sec.)	C	F	G	H	I
0 - 1	12	17	7	12	7
1 - 2	39	58	61	61	58
2 - 3	27	29	35	20	26
3 - 4	10	8	13	16	15
4 - 5	7	6	6	8	9
5 - 6	4	4	6	4	6
6 - 7	5	3	0	1	3
7 - 8	4	2	1	2	0
8 - 9	0	1	0	0	0
9 - 10	0	0	0	0	0
10 - 11	0	0	0	0	0
11 - 12	0	0	0	0	0
12 - 13	0	0	0	0	0
13 - 14	0	0	0	0	0
14 - 15	0	0	0	0	0
15 - 16	0	0	0	0	0
16 - 17	0	0	0	0	0
17 - 18	0	0	0	0	0
18 - 19	0	0	0	0	0
19 - 20	0	0	0	0	0
20 - 21	0	0	0	0	0
21 - 22	0	0	0	0	0
22 - 23	0	0	0	0	0
23 - 24	0	0	0	0	0
24 - 25	0	0	0	0	0



APPENDIX B continued

FREQUENCY OF GAPS-FREEWAY RAMP SPACING STUDIES

Brays Bayou, Feb. 18. 7:05-7:10 A.M., On Ramp Closed

Gap Size (Sec.)	C	F	G	H	I
0 - 2	51	75	68	73	65
2 - 4	37	37	48	36	41
4 - 6	11	10	12	12	15
6 - 8	9	5	1	3	3
8 - 10	0	1	0	0	0
10 - 12	0	0	0	0	0
12 - 14	0	0	0	0	0
14 - 16	0	0	0	0	0
16 - 18	0	0	0	0	0
18 - 20	0	0	0	0	0
20 - 22	0	0	0	0	0
22 - 24	0	0	0	0	0
24 - 26	0	0	0	0	0
26 - 28	0	0	0	0	0
28 - 30	0	0	0	0	0
30 - 32	0	0	0	0	0
32 - 34	0	0	0	0	0
34 - 36	0	0	0	0	0
36 - 38	0	0	0	0	0
38 - 40	0	0	0	0	0
40 - 42	0	0	0	0	0
42 - 44	0	0	0	0	0
44 - 46	0	0	0	0	0
46 - 48	0	0	0	0	0
48 - 50	0	0	0	0	0

APPENDIX B continued

FREQUENCY OF GAPS-FREEWAY RAMP SPACING STUDIES

Brays Bayou, Feb. 18, 7:20-7:25 A.M., On Ramp Open

Gap Size (Sec.)	C	F	G	H	I
0 - 1	8	3	5	3	2
1 - 2	44	36	30	33	24
2 - 3	22	29	27	30	29
3 - 4	19	15	15	12	15
4 - 5	9	12	14	3	9
5 - 6	7	1	2	3	8
6 - 7	0	2	0	0	2
7 - 8	1	1	1	1	2
8 - 9	1	1	1	0	1
9 - 10	1	0	0	1	0
10 - 11	0	0	0	1	0
11 - 12	0	0	0	0	1
12 - 13	0	0	0	0	0
13 - 14	0	0	0	0	0
14 - 15	0	0	0	0	0
15 - 16	0	0	0	0	0
16 - 17	0	0	0	0	0
17 - 18	0	0	0	0	0
18 - 19	0	0	0	0	0
19 - 20	0	0	0	0	0
20 - 21	0	0	0	0	0
21 - 22	0	0	0	0	0
22 - 23	0	0	0	0	0
23 - 24	0	0	0	0	0
24 - 25	0	0	0	0	0

APPENDIX B continued

FREQUENCY OF GAPS-FREEWAY RAMP SPACING STUDIES

Brays Bayou, Feb. 18, 7:20-8:00 A.M., On Ramp Open

Gap Size (Sec.)	C	F	G	H	I
0 - 2	251	280	254	216	138
2 - 4	276	378	375	364	401
4 - 6	112	102	104	104	125
6 - 8	50	45	24	25	35
8 - 10	18	11	13	15	10
10 - 12	5	3	7	10	4
12 - 14	6	1	3	2	0
14 - 16	4	1	0	0	1
16 - 18	2	1	1	1	1
18 - 20	0	1	1	0	0
20 - 22	1	0	0	0	1
22 - 24	0	0	0	0	0
24 - 26	0	0	0	0	0
26 - 28	0	0	0	0	0
28 - 30	0	0	0	0	0
30 - 32	0	0	0	0	0
32 - 34	0	0	0	0	0
34 - 36	0	0	0	0	0
36 - 38	0	0	0	0	0
38 - 40	0	0	0	0	0
40 - 42	0	0	0	0	0
42 - 44	0	0	0	0	0
44 - 46	0	0	0	0	0
46 - 48	0	0	0	0	0
48 - 50	0	0	0	0	0

## APPENDIX C

Calculation of the Minimum Distance  
Between an On-Ramp and an Off-Ramp

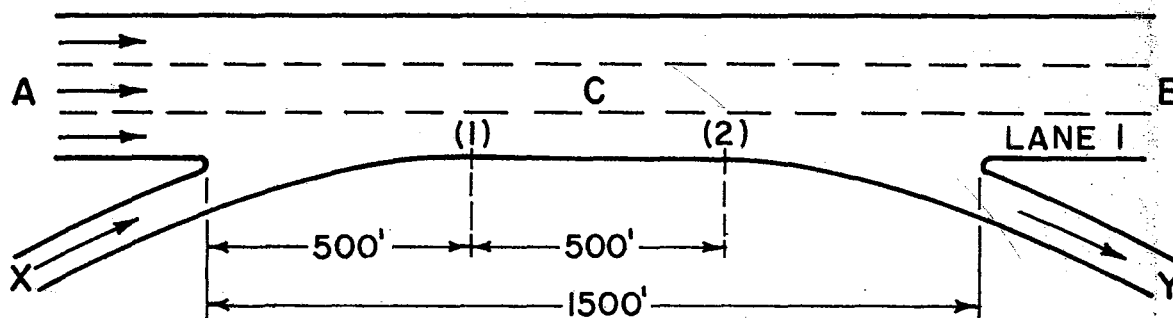

$C = 5400$   
 A to B = 4150  
 X to Y = 0  
 X to B = 625  
 Y to B = 625

Find lane volumes

a. Average lane volume =  $5400 \div 3 = 1800$

b. Check lane 1 volume at (1)

1. Thru traffic in right lane  
= 14% = .14 (4150) = 580

2. On-ramp traffic in right lane  
= 1.00 (625) = 625

3. Off-ramp traffic in right lane  
= .94 (625) = 587

Total in right lane at (1) = 1792

c. Check lane 1 volume at (2)

1. Thru traffic in right lane = 580

2. On-ramp traffic in right lane (.60 x 625) = 375

3. Off-ramp traffic in right lane (1.00 x 625) = 625

Total in right lane at (2) = 1580

Since the right lane volumes at both (1) and (2) are less than 1800 vehicles per hour, this design is satisfactory to accommodate the assumed volumes.