



Test Specifications for SPST and HWTT

Product 5-6744-01-P1

Cooperative Research Program

TEXAS A&M TRANSPORTATION INSTITUTE
COLLEGE STATION, TEXAS

in cooperation with the
Federal Highway Administration and the
Texas Department of Transportation
<http://tti.tamu.edu/documents/5-6744-01-P1.pdf>

Project 5-6744-01: Implementation of the HMA Shear Test
for Routine Mix-Design and Screening

Product 5-6744-01-P1

Test Specifications for SPST and HWTT



by

Lubinda F. Walubita, Tito Nyamuhokya, and Sang Ick Lee
TTI – The Texas A&M University System, College Station

|Published: February 2019 |

TEST SPECIFICATIONS FOR SPST AND HWTT

by

Lubinda F. Walubita
Research Scientist
Texas A&M Transportation Institute

Tito Nyamuhokya
Associate Transportation Researcher
Texas A&M Transportation Institute

and

Sang Ick Lee
Assistant Research Engineer
Texas A&M Transportation Institute

Product 5-6744-01-P1

Project 5-6744-01

Project Title: Implementation of the HMA Shear Test for Routine Mix-design and screening

Performed in cooperation with the
Texas Department of Transportation
and the
Federal Highway Administration

Published: February 2019

TEXAS A&M TRANSPORTATION INSTITUTE
College Station, Texas 77843-3135

DISCLAIMER

This research was performed in cooperation with the Texas Department of Transportation (TxDOT) and the Federal Highway Administration (FHWA). The contents of this report reflect the views of the authors, who are responsible for the facts and the accuracy of the data presented herein. The contents do not necessarily reflect the official view or policies of the FHWA or TxDOT. This report does not constitute a standard, specification, or regulation.

This report is not intended for construction, bidding, or permit purposes. The researcher in charge of the project was Lubinda F. Walubita.

The United States Government and the State of Texas do not endorse products or manufacturers. Trade or manufacturers' names appear herein solely because they are considered essential to the object of this report.

ACKNOWLEDGMENTS

This project was conducted in cooperation with TxDOT and FHWA. The authors thank Kevin Pete (the project manager), Joe Adams (the previous project manager), and all members of the project team for their participation and feedback.

TABLE OF CONTENTS

	Page
List of Symbols and Notations	viii
Introduction.....	1
Part A: Proposed Modifications to the HWTT and TEX-242-F Test Procedure	3
Part B: The Proposed Draft Test Specification for SPST.....	13
References	19

LIST OF SYMBOLS AND NOTATIONS

AC	Asphalt-binder Content
APT	Accelerated Pavement Testing
HDPE	High-density polyethylene
HMA	Hot Mix Asphalt
HWTT	Hamburg Wheel-Tracking Test
PFC	Permeable Friction Course
PG	Performance Grade
SGC	Superpave Gyratory Compactor
SPST	Simple Punching Shear Test
WMA	Warm Mix Asphalt

INTRODUCTION

This document is divided into two major parts: Part A and B. Part A documents some proposed modifications to the Hamburg wheel-tracking test (HWTT) and Tex 242-F test procedure, whereas Part B documents the proposed tentative specification and test procedures for the simple punching shear test (SPST).

For Part A (HWTT specification), the major modification is in Section 6.5 where the procedure to handle mixtures at higher HWTT test temperatures is described. TxDOT Project 5-6744-01 found most hot mix asphalt (HMA) mixtures fail rapidly when subjected to higher HWTT temperatures (60°C). Nevertheless, those that survive require a closer look onto the response rutting plots and determination if adjustments are needed as explained in Section 6.5. In fact, researchers found performance grade (PG) 76 mixtures are most probable to sustain the HWTT water bath temperature of 60°C without collapsing than lower PG mixtures (1). Based on this observation/finding, researchers suggest that a mixture with less than PG 76 may be subjected to HWTT testing at 60°C only if stripping assessment is the primary reason for the test. Note that all the proposed/suggested modifications to Part A (HWTT specification) are highlighted in yellow coloring.

Part B is a tentative proposed draft specification for SPST testing. The major output of this SPST protocol are HMA shear strength, shear strain, shear modulus, shear strain energy, and shear strain energy index. Of all these SPST parameters, only shear strength and shear strain energy index were found to have a good correlation with field rutting and HWTT testing (1, 2, 3). Based on these results and study findings (1, 2, 3), researchers suggested that the HMA-SPST screening criteria should be a shear strength of not less than 300 psi at 50°C and should not drop below 200 psi at 60°C. Table 1 exemplifies some HMA mixtures that passed HWTT criteria (rut <0.5 in.) at 50°C and 60°C and their corresponding shear strength to further substantiate the proposed SPST screening criteria. The mixtures identified have minimum shear strength of about 200 psi at 60°C. Likewise, the mixtures show minimum shear strength of about 300 psi at 50°C.

Table 1. Example HWTT (Rutting) and SPST (Shear Strength) Results.

HMA Mixture ID	HWTT Rut (in.) at 50°C	HWTT Rut (in.) at 60°C	SPST Shear Strength (psi) at 50°C	SPST Shear Strength (psi) at 60°C
Type C / PG 76-22 / 4.7% AC/Laredo	0.07	0.20	354.71	198.40
Type D / PG 76-22 / 4.5% AC / Chico	0.07	0.18	300.41	281.33
Type C surface SH 304	0.10	0.39	311.10	215.01
Type D / PG 76-22 / 5% AC / Chico	0.12	0.23	309.98	228.94
Type B/APT site/Arlington	0.18	0.48	300.18	226.52
Laboratory screening criteria	≤ 0.50	≤ 0.50	≥ 300	≥ 200

AC = Asphalt-binder content; APT = accelerated pavement tracking

PART A: PROPOSED MODIFICATIONS TO THE HWTT AND TEX-242-F TEST PROCEDURE

Test Procedure for

HAMBURG WHEEL TRACKING TEST

TX DOT Designation: Tex-242-F

Effective Date: _____



1. SCOPE

- 1.1 Use this test method to determine the premature failure susceptibility of bituminous mixtures due to weakness in the aggregate structure, inadequate binder stiffness, or moisture damage and other factors including inadequate adhesion between the asphalt binder and aggregate (stripping). *The test method measures the rutting susceptibility of bituminous mixtures in terms of the following rutting parameters: rut depth, number of passes to failure, normalized rutting area, and shape factor.*
- 1.2 The values given in parentheses (if provided) are not standard and may not be exact mathematical conversions. Use each system of units separately. Combining values from the two systems may result in nonconformance with the standard.

2. APPARATUS

- 2.1 *Wheel Tracking Device*, an electrically powered device capable of moving a steel wheel with a diameter of 8 in. (203.6 mm) and width of 1.85 in. (47 mm) over a test specimen.
 - 2.1.1 The load applied by the wheel is 158±5 lb (705±22 N).
 - 2.1.2 The wheel must reciprocate over the test specimen, with the position varying sinusoidally over time.
 - 2.1.3 The wheel must be capable of making 50±2 passes across the test specimen per minute.

Note 1— *For mixtures to be used in slow vehicle-speed areas such as intersections, urban city roads, etc., testing at lower and/or multiple HWTT wheel*

speeds should be considered as a supplement to the standard speed (50±2 passes/minute) (i.e., from 50 to as low as 35 passes/minute). In order to facilitate this, the HWTT wheel should have the capabilities to run at wheel speeds ranging from 35 to 50 passes per minute.

- 2.1.4 The maximum speed of the wheel must be approximately 1.1 ft/s (0.305 m/s) and will be reached at the midpoint of the slab.
- 2.2 *Temperature Control System*, a water bath capable of controlling the test temperature within ±4°F (2°C) over a range of 77–158°F (25–70°C).
 - 2.2.1 This water bath must have a mechanical circulating system to stabilize temperature within the specimen tank.
- 2.3 *Rut Depth Measurement System*, a Linear Variable Differential Transducer device capable of measuring the rut depth induced by the steel wheel within 0.0004 in. (0.01 mm), over a minimum range of 0.8 in. (20 mm).
 - 2.3.1 The system should be mounted, to measure the rut depth at the midpoint of the wheel's path on the slab.
 - 2.3.2 Take rut depth measurements at least every 100 passes of the wheel.
 - 2.3.3 This system must be capable of measuring the rut depth without stopping the wheel. Reference this measurement to the number of wheel passes.
 - 2.3.4 The system should have a fully automated data acquisition and test control system (computer included).
- 2.4 *Wheel Pass Counter*, a non-contacting solenoid that counts each wheel pass over the test specimen.
 - 2.4.1 Couple the signal from this counter to the rut depth measurement, allowing the rut depth to be expressed as a fraction of the wheel passes.
- 2.5 *Specimen Mounting System*, a stainless steel tray that can be mounted rigidly to the machine in the water bath.
 - 2.5.1 This mounting must restrict shifting of the specimen during testing.
 - 2.5.2 The system must suspend the specimen, allowing free circulation of the water bath on all sides.

- 2.5.3 The mounting system must provide a minimum of 0.79 in. (2 cm) of free circulating water on all sides of the sample.
-

3. MATERIALS

- 3.1 *Three high-density polyethylene (HDPE) molds*, shaped according to plan view in Figure 2 to secure circular, cylindrical test specimens. Use one mold for cutting the specimen and the other two for performing the test.

- 3.2 *Capping compound*, able to withstand 890 N (200 lb) load without cracking.

4. SPECIMEN

- 4.1 *Laboratory Molded Specimen*—Prepare specimens in accordance with Tex-205-F and Tex-241-F. Specimen diameter must be 6 in. (150 mm), and specimen height must be 2.5 ± 0.1 in. (63.5 ± 2.5 mm).

Note 2— *For consistency, test all specimens within 5 days of molding.*

Note 3—Mixtures modified with warm-mix asphalt (WMA) additives or processes must be oven cured at 275°F for a maximum of 4 hours before molding.

- 4.1.1 Density of test specimens must be 93 ± 1 percent (or Air void must be 7 ± 1 percent).

Note 4—Mixture weights for specimens prepared in the laboratory typically vary between 2400 and 2600 g to achieve density due to different aggregate sources and mix types. *If necessary, a pre-molding procedure should be conducted to systematically achieve the desired specimen density (93 ± 1 percent) for the laboratory-molded samples. The pre-molding procedure consists of molding at least three specimens, each with a different target density varied roughly between 87 percent and 92 percent, and evaluating the resulting specimen densities for each. A target density versus obtained specimen density curve is drawn to determine the Optimum Molding Density that will yield the desired specimen density (93 ± 1 percent); see example in Figure 1.*

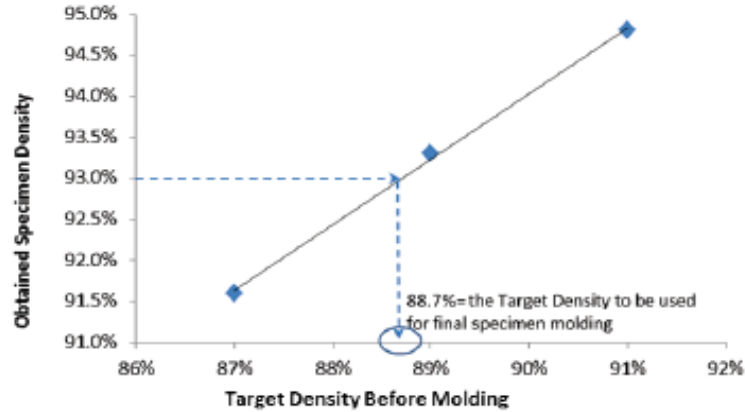
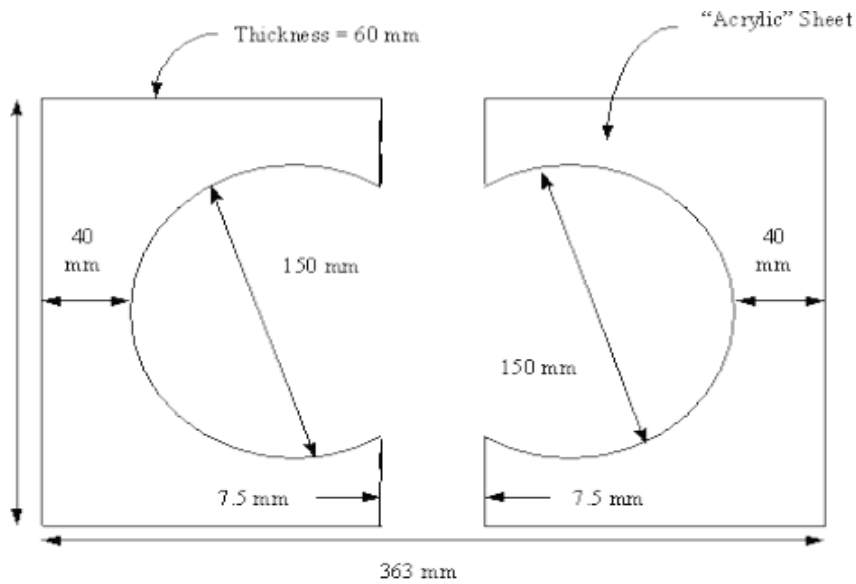

Figure 1 Pre-molding procedure

- 4.2 *Core Specimen*—Specimen diameter must be 6 ± 0.1 in. (150 ± 2 mm). There is not a specific density requirement for core specimens.



** Not drawn to scale

Figure 2. Specimen Configuration for the Hamburg Wheel Tracking Device

5. PROCEDURE

- 5.1 Use two cylindrically molded specimens meeting the requirements of Section 4.
- 5.2 Measure the relative density of specimens in accordance with Tex-207-F and Tex-227-F.

- 5.3 Place a specimen in the cutting template mold and use masonry saw to cut it along the edge of the mold.
- 5.3.1 The cut across the specimen should be approximately 5/8 in. (16 mm) deep.
- 5.3.2 Cut the specimen to the dimensions shown in Figure 2 in order to fit in the molds required for performing the test.
- 5.4 For specimens 6 in. (150 mm) in diameter:
- Place the HDPE molds into the mounting tray and fit specimens into each one.
 - Secure the molds into the mounting tray.
- Note 5**— Do not use the HDPE molds for core specimens greater than 6 in. (152 mm) in diameter.
- Note 6**— *Keep track of the top and bottom of the specimen according to the direction of sample compaction or traffic loading in the case of field cores. Always place the specimen in the HWTT machine such that the top surface of the specimen is in contact with the wheel (i.e., direction of loading is parallel to the direction of sample compaction).*
- 5.5 For specimens greater than 6 in. (150 mm) in diameter:
- Mix capping compound.
 - Spray the mounting tray with a light lubricant.
 - Place specimen in the middle of the mounting tray.
 - Spread the capping compound around the core specimen until level with the surface.
 - Allow the capping compound to dry for a minimum of 24 hours.
- 5.6 Fasten the mounting trays into the empty water bath.
- 5.7 Start the software supplied with the machine, and enter the required test information into the computer including adjusting speed where needed.
- Note 7**— *For mixtures to be used in slow vehicle-speed areas such as intersections, urban city roads, etc., testing at lower and/or multiple HWTT wheel speeds should be considered in addition to the 50±2 passes/minute (i.e., from 50 to as low as 35 passes/minute). For these special slow vehicle-speed areas, any or all of the following HWTT wheel speeds can be considered: 50, 45, 40, and/or 35 passes /minute.*
- 5.8 Set the test temperature at 122±2°F (50±1°C) for all HMA specimens.
- Note 8**— *For mixtures to be placed in high-temperature areas, high shear stress locations, and urban stop-go environments (near intersections), consider testing the samples at multiple HWTT temperatures (i.e., 50°C and, 60°C) and report the test results for all the tested temperatures.*

- 5.8.1 Fill the water bath with the water and wait until the water temperature is at the desired test temperature.
- 5.8.2 Monitor the temperature of the water on the computer screen.
- 5.8.3 Saturate the test specimen in the water for an additional 30 minutes after reaching the desired water temperature.
- 5.8.4 Start the test after the test specimens have been in the water for 30 minutes at the desired test temperature. The testing device automatically stops the test when the device applies the number of desired passes or when reaching the maximum allowable rut depth.

6. CALCULATIONS

- 6.1 *From the HWTT machine, save and extract the rut depth versus number of passes data for calculation of HWTT rutting parameters.*
- 6.2 *Measure and record the following parameters from the rut depth versus number of passes response:*
 - *Maximum Rut Depth Rut_{max} = Rutting after 20,000 load passes or 12.5 mm (whichever is smaller)*
 - *Failure Cycles, N_d = Number of load passes to reach 12.5 mm rutting or 20,000 (whichever is smaller)*
 - *ΔA = Area under the Rut depth versus number of passes (Figure 3)*
Note 9— *Rut_{max} and N_d are the traditional HWTT parameters and can be obtained directly from the machine.*

Note 10— *The Area under the rut depth versus number of passes, ΔA , is calculated using the trapezoidal formula by dividing the area into n number of trapezoids. (Alternatively, Simpson's rule may be used to determine the area under the curve.)*

$$\Delta A = \frac{N_d}{2n} [f(x_0) + 2f(x_1) + 2f(x_2) \dots + 2f(x_{n-1}) + f(x_n)]$$

where $f(x_1)$ and $f(x_{i+1})$ are rut depth values at the left and right end of each trapezoid, respectively.

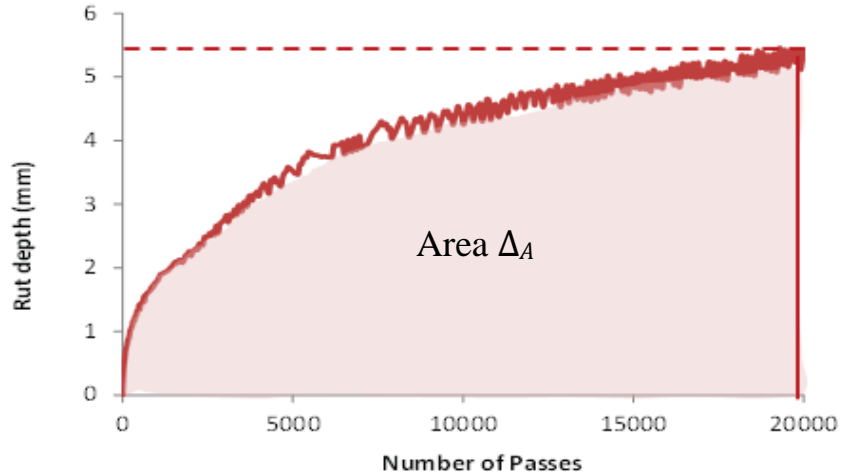

Figure 3. HWTT Rut depth versus number of load passes curve

6.3 Calculate the Normalized Rutting Area (Rut_{Δ}):

$$Rut_{\Delta} = \frac{\text{Area under Rutting curve}}{N_d} = \frac{\Delta_A}{N_d}$$

Note 11— the Normalized Rutting Area (Rut_{Δ}) parameter accounts for the rutting path-history of the sample. Higher Rut_{Δ} indicates poor rut resistance.

6.4 Calculate the Shape Factor (SF)

$$SF = \frac{\text{Area under Rutting curve}}{\text{Area under triangular curve}} = \frac{\Delta_A}{N_d \times 0.5 \times Rut_{\max}} = \frac{\Delta_A}{\Delta_B}$$

Note 12— the Shape Factor (SF) parameter indicates the shape of the rutting curve. $SF > 1.25$ indicates a convex rutting curve, which is less desirable for high-temperature areas, high shear stress locations, and urban stop-go sections in terms of the early rutting life of the HMA mix. SF is calculated based on the area under the curve and area under the curve in Figure 4.

$SF \leq 1.25$ indicates a concave rutting curve, which is more desirable for high-temperature areas, high shear stress locations, and urban stop-go sections, particularly in terms of the early rutting life of the HMA mix.

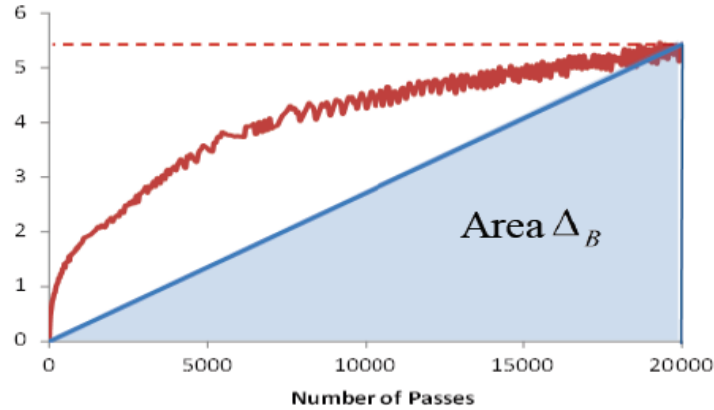

Figure 4. HWTT-Area under triangular curve

6.5 Plot and assess the rut depth versus the number of passes response plot

Note 13— Typical HWTT plot is divided into two slopes, one before and the other after the stripping point. However, in many instances especially at higher temperature (60°C), the slope after the stripping point subdivides itself into more than one. If that happens, the number of HWTT load passes (N_d) to failure may be overstated. In order to establish the actual load passes corresponding to the recommended TxDOT rut cut-off point, the following should be considered as shown in Figure 5.

- Extend the slope after stripping point to intersect a horizontal line from 0.5 in. (12.5 mm). From the intersection of the two lines, draw a vertical line to touch the horizontal axis and establish the new load passes corresponding to failure point.

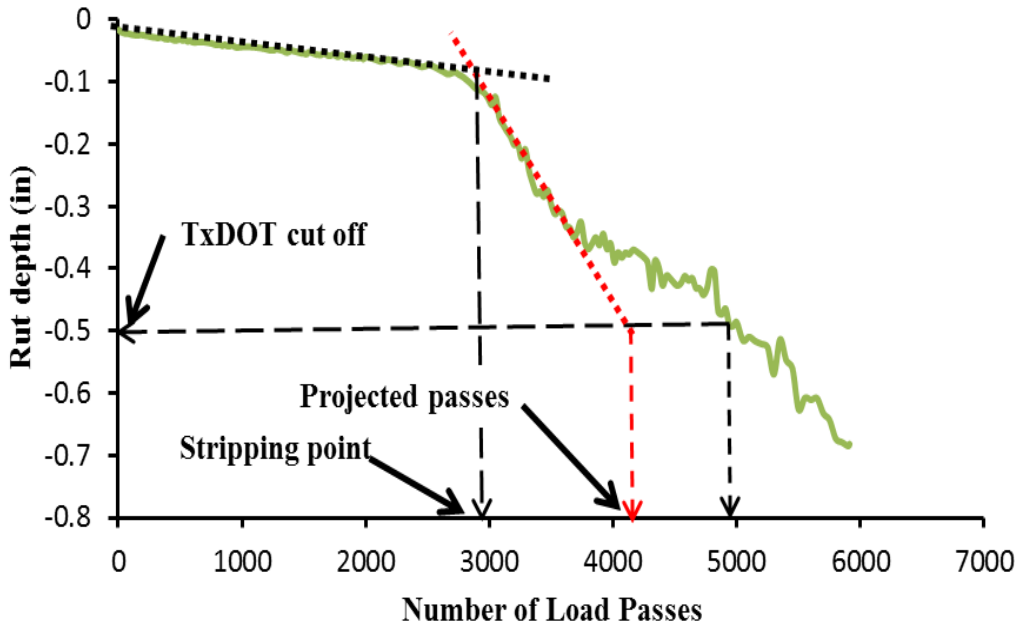

Figure 5. Typical HWTT responses at 60°C

Note 14— Apply the HWTT water bath temperature of 60°C only for HMA mixtures using PG 76 or above. HMA mixtures with lower PG grade will probably collapse due to early stripping. In case stripping is the only and primary reason for the test, HMA mixtures with less than PG 76 can also be subjected to HWTT testing at 60°C.

7. REPORT

7.1 Report the following for each specimen:

- Trimmed specimen density,
- Anti-stripping additive used,
- Test temperature,
- Maximum Rut Depth, Rut_{max} ,
- Failure Cycles, N_d ,
- Normalized Rutting Area, $Rut\Delta$, and
- Shape Factor, SF .

8. ARCHIVED VERSIONS

8.1 Archived versions are available.

PART B: THE PROPOSED DRAFT TEST SPECIFICATION FOR SPST

Test Procedure for

THE SIMPLE PUNCHING SHEAR TEST (SPST)

TxDOT Designation: Tex-2XX-F



Effective Date:

1. SCOPE

- 1.1 This test method determines the shear properties of the compacted bituminous mixtures. The measurable and calculable shear parameters include shear strength, shear strain, shear modulus, shear strain energy, and shear strain energy index.
 - 1.2 The values given in parentheses (if provided) are not standard and may not be exact mathematical conversions. Use each system of units separately. Combining values from the two systems may result in nonconformance with the standard.
-

2. APPARATUS

- 2.1 *Loading Press*, capable of applying a compressive load at a controlled deformation mode at the rate of 0.2 mm per second.
- 2.2 *Environmental chamber*, a temperature-controlled chamber capable of maintaining a temperature of up to 60°C.
- 2.3 *Loading Head*, a 1.5 in. diameter cylindrical metal head to be attached to the loading shaft of the Loading Press (Figure 1).
- 2.4 *Loading Base*, consisting of a 6.0 in. diameter cylindrical metal base with a 2.5 in. diameter concentric opening. The height of the Loading Base is at least 2.5 in. to allow enough space for accommodating the dislodged parts of the HMA (Figure 2).
- 2.5 *Sample Confinement*, made of a cylindrical enclosure and a collar strap to provide lateral confining pressure of about 20 psi to the sample (Figure 3).
- 2.6 *Torque Wrench*, with a torque capacity of 25 in-lb and appropriate socket drive handle.



Figure 1. Loading head.



Figure 2. Loading base pictorial illustration.



Figure 3. SPST sample confinement: Cylindrical enclosure and collar strap.

3. SPECIMENS

3.1 *Laboratory-Molded Specimens*—prepare three specimens in accordance with Tex-241-F. Specimen diameter must be 6 in. (150 mm), and height must be 2.5 ± 0.1 in. (63.5 ± 2.5 mm). For consistency, test all specimens within 5 days of molding.

3.1.1 For WMA mixtures, select curing temperature and time according to binder grade, recycled materials, and target discharge temperature. Refer to Tex-241-F to mold WMA specimens.

Note 1—Cure WMA mixtures at 275°F for 4 hr±5 min. before molding. WMA is defined as HMA that is produced within a target temperature discharge range of 215°F and 275°F using WMA additives or processes.

3.1.2 Test specimen air void must be 7 ± 1 percent, except for Permeable Friction Course (PFC) mixtures.

Note 2— Mixture weights for specimens prepared in the laboratory typically vary between 2400 and 2600 g to achieve the needed air-void due to different aggregate sources and mix types. A minimum of 3 pre-molded samples of different weight followed by interpolation to determine the actual weight that will produce samples with target density of 7 ± 1 percent air void.

- 3.1.3 For PFC mixtures, mold test specimens to 50 gyrations (N_{design}).
Note 3— Select the mixture weight for the molded PFC specimens based on the weight used in the mix design.
- 3.2 *Core Specimens*—Specimen diameter must be 6 ± 0.1 in. (150 ± 2.5 mm), and height must be a minimum of 1.5 in. (38 mm). There is not a specific density requirement for core specimens.

4. PROCEDURE

- 4.1 For laboratory-produced mixtures, proceed to Section 4.2. For plant-produced mixtures, proceed to Section 4.3. For roadway cores, proceed to Section 4.4.
- 4.2 *Laboratory-Produced Mixtures:*
- 4.2.1 Combine aggregates and prepare laboratory mixture as described in Tex-205-F.
- 4.2.2 Mold three specimens in accordance with Tex-241-F with the Superpave Gyrotory Compactor (SGC).
- 4.2.3 Proceed to Section 4.4.
- 4.3 *Plant-Produced Mixtures:*
- 4.3.1 Sample the plant mixture in accordance with Tex-222-F.
- 4.3.2 Mold three specimens in accordance with Tex-241-F with the SGC.
- 4.3.3 Proceed to Section 4.4.
- 4.4 Measure and record the density, height, and diameter of each laboratory or plant-produced specimen or roadway core.
- 4.5 Place the specimens or cores, along with the testing apparatus (loading head, loading base, sample confinement), in the controlled temperature chamber for at least 3 hours to ensure a consistent temperature of $50\pm 1^{\circ}\text{C}$ throughout. Always monitor the temperature using a dummy sample.

Note 4— For mixes to be placed in high-temperature areas, high shear stress locations, and urban stop-go environments (near intersections), test the samples at multiple temperatures (i.e., 50°C and 60°C), and report the test results for all tested temperatures.

- 4.6 Attach the Sample Confinement to the specimen.
- 4.7 Carefully place the confined specimen on the Loading Base. Make sure the Loading Base and the specimen are concentrically placed below the Loading Head (Figure 4).

Note 5— Keep track of the top and bottom of the specimen according to the direction of sample compaction or traffic loading in the case of field cores.



Figure 4. SPST specimen setup.

- 4.8 Slowly lower the Loading head to lightly seat on the surface of the specimen.
- 4.9 Apply the load at a controlled deformation rate of 0.2 mm per second. Capture and save the complete load versus deformation (L-D) response curve for subsequent data analysis.
- 4.10 An operator shall observe the development of the load-deformation response curve in real time. The operator shall stop the test when the shear load passes the maximum point and fallen back to zero point.

5. CALCULATIONS

- 5.1 Measure and record the following parameters from the load-displacement response (Figure 5):
- Peak (failure) shear load, P_{\max}

- Failure shear deformation at peak load, $D@P_{max}$
- Area under the shear load-displacement (L-D) response curve = $\int f(x) dx$

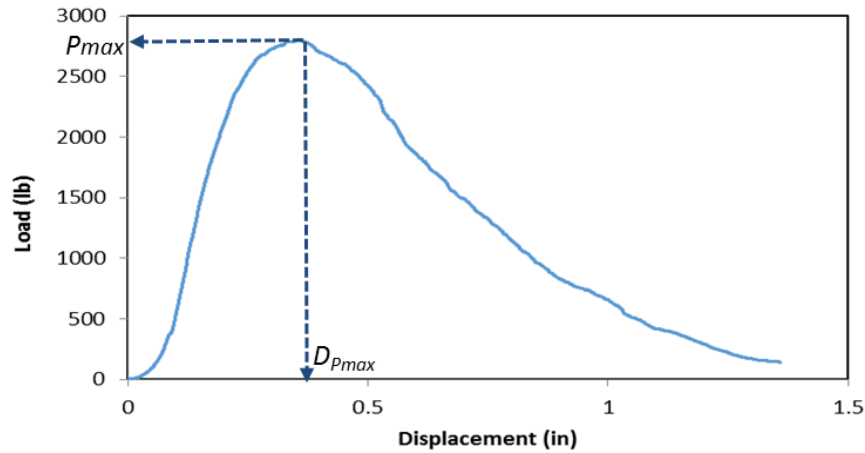

Figure 5. Typical SPST load-displacement curve.

Note 6— The Area under the shear load-displacement (L-D) response curve, $\int f(x)dx$ may be approximated using trapezoidal rule (*Alternatively, Simpson’s rule may be used to determine the area under the curve*).

$$\Delta A = \frac{N_d}{2n} [f(x_0) + 2f(x_1) + 2f(x_2) \dots + 2f(x_{n-1}) + f(x_n)]$$

where $f(x_1)$ and $f(x_{i+1})$ are rut depth values at the left and right end of each trapezoid, respectively.

5.2 Calculate the HMA shear strength, τ (psi):

$$\tau = \frac{P_{max}}{\pi t d}$$

where, d = Diameter of the punching (loading) head = 1.5 in.

t = Thickness of the sample (in.)

5.3 Calculate the HMA failure shear strain at peak load, γ :

$$\gamma = \frac{D @ P_{max}}{t}$$

where, D = Displacement (in.)

5.4 Calculate the HMA shear modulus, E (psi):

$$E = \frac{\tau}{\gamma}$$

5.5 Calculate the shear strain energy, SSE (KJ/m²):

$$SSE = \frac{\text{Area Under Curve}}{\text{Sheared Surface Area}} = \frac{1}{\pi t d} \int f(x) dx$$

5.6 Calculate the SSE Index:

$$SSE \text{ index} = 10^3 \times SSE \frac{\gamma}{t\tau}$$

Note 6— Mixture selection criteria: The shear strength of the mixtures shall not be less than 300 psi (or $SSE \geq 25 \text{ kJ/m}^2$) at 50°C. The shear strength shall not drop below 200 psi (or $SSE \geq 17 \text{ kJ/m}^2$) at 60°C, otherwise, the HMA mixture shall be deemed too sensitive to temperature changes.

6. REPORT

6.1 Report the following for each specimen:

- Trimmed specimen density,
 - Peak shear (failure) load,
 - Failure shear deformation at peak load,
 - HMA shear strength,
 - HMA failure shear strain at peak load,
 - HMA shear modulus,
 - Shear strain energy,
 - Shear strain energy Index, and
 - Additional comments.
-

7. ARCHIVED VERSIONS

7.1 Archived versions are available.

REFERENCES

- 1 Walubita, L. F., and Nyamuhokya T. (2017). Implementation of the HMA Shear Test for Routine Mix-design and screening: Technical Memorandum 2. TxDOT Project 5-6744-01. Texas A&M Transportation Institute, College Station, TX.
- 2 Walubita, L. F., Nyamuhokya T., and Lee S. (2018). Implementation of the HMA Shear Test for Routine Mix-design and screening: Technical Memorandum 3. TxDOT Project 5-6744-01. Texas A&M Transportation Institute, College Station, TX.
- 3 Walubita et al. (2014). HMA Shear Resistance, Permanent Deformation, and Rutting Tests for Texas Mixes: Final Year-2 Report. Technical Report FHWA/TX-15/0-6744-2. Texas A&M Transportation Institute, College Station, TX.

