

5-4020-01-P1  
September 2004

TEXAS TRANSPORTATION INSTITUTE  

---

Transportation Operations Group

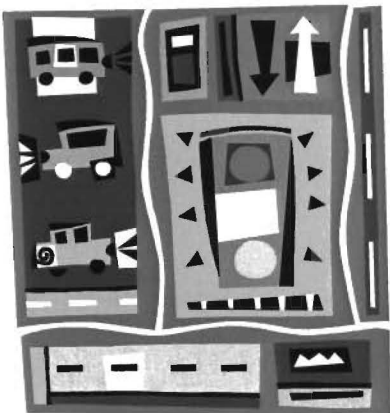

# PASSER V

TRF 314

# ***Signal Optimization and Analysis Using PASSER V Training Workshop***

---

**Nadeem Chaudhary, P.E.  
Steven Venglar, P.E.  
Chi-Leung Chu**

**Sponsored by TxDOT under Project 5-4020**



*Transportation Operations Group*

**1**

## ***Session 0: Preliminaries***

- **Self Introductions**
- **Workshop Objectives**
- **Workshop Outline**



*Transportation Operations Group*

**2**

## ***S0 – Workshop Objectives***

- **Learn Use of PASSER V for Analysis and Optimization of Traffic Signals:**
  - ✓ **Isolated Signals**
  - ✓ **Isolated Diamond Interchanges**
  - ✓ **Diamonds + Adjacent Signals**
  - ✓ **Arterials and Sub-arterials**

## ***S0 – Workshop Outline***

- **S1: Introduction to PASSER V**
  - ✓ **Features**
  - ✓ **Input Data Requirements**
- **S2: Isolated Signals**
  - ✓ **Review of Theory**
  - ✓ **Isolated Signal Exercise**
- **S3: Signal Systems**
  - ✓ **Review of Theory**

## ***S0–Workshop Outline*** *(continued)*

- **S4: Diamond Interchange Exercise**
  - ✓ **Additional Discussion**
- **S5: Arterial Exercises**
  - ✓ **Analyze Simple Arterials**
  - ✓ **Review Additional Features**
- **S6: Diamond + Arterial Exercise**
  - ✓ **Coordinating Diamond with Adjacent Signals**

## ***S0–Workshop Outline*** *(continued)*

- **S7: Workshop Conclusion**
  - ✓ **Multi-Arterial Network Case Studies**
  - ✓ **Question/Answer Session**
  - ✓ **Workshop Survey**

## ***Session 1: Introduction to PASSER V***

- **Background**
- **Features**
- **Input Data Requirements**
- **User Interface**

## ***S1 – PASSER V Background***

- **Funded by TxDOT and TTI**
- **Applications**
  - ✓ **Isolated Signals (Building Blocks)**
  - ✓ **Signalized Arterials**
  - ✓ **Isolated Diamond Interchanges**
  - ✓ **Diamond + Adjacent Signals**

## ***S1–PASSER V Features***

- **Graphic User Interface**
  - ✓ **Multiple Document Architecture**
- **New Delay/Traffic Model**
- **Can Coordinate Signals to Provide**
  - ✓ **Maximum Progression**
  - ✓ **Minimum Delay**
- **Graphic Time-Space Diagram**

## ***S1–Using PASSER V***

- **Draw the Facility**
- **Select Intersection or Link**
- **Enter Corresponding Data**
- **View Signal MOEs**
- **Analyze/Optimize Signal Systems**
  - ✓ **Select and Run Tool**
  - ✓ **View/Print Results**

## ***S1 – Tools in PASSER V***

- **PASSER II Optimizer**
- **PASSER III Optimizer**
- **GA-Based Optimizer**
- **Time-Space Diagram Generator**
- **Volume Analysis**
- **Delay Analysis**

## ***S1 – PASSER V Limitations***

- **Coordination Requires Same Cycle Length at All Signals**
  - ✓ **No Double-Cycling or Conditional Service**
- **Cannot Handle Following Cases**
  - ✓ **Network Optimization**
  - ✓ **Un-Signalized Intersections**

## ***Session 2: Isolated Signals***

- **Overview of Theory**
- **PASSER V Input Data Needs**
- **Input Data Considerations**
- **Signal Exercise**

## ***S2–Cycle vs. Delay and Capacity***

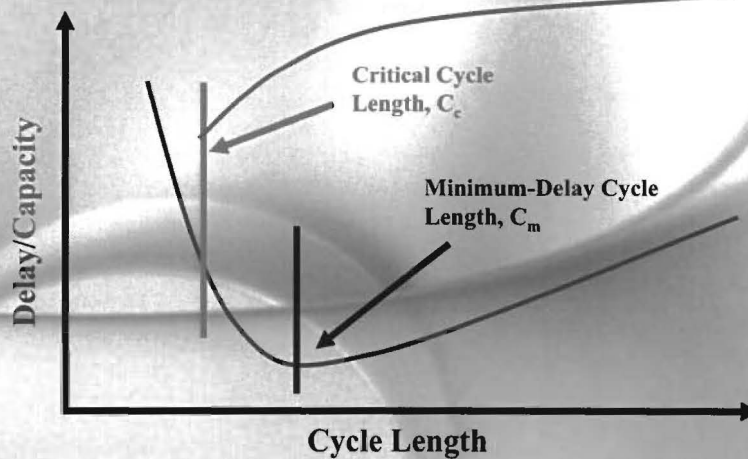



## *S2-Cycle vs. Delay and Stops*

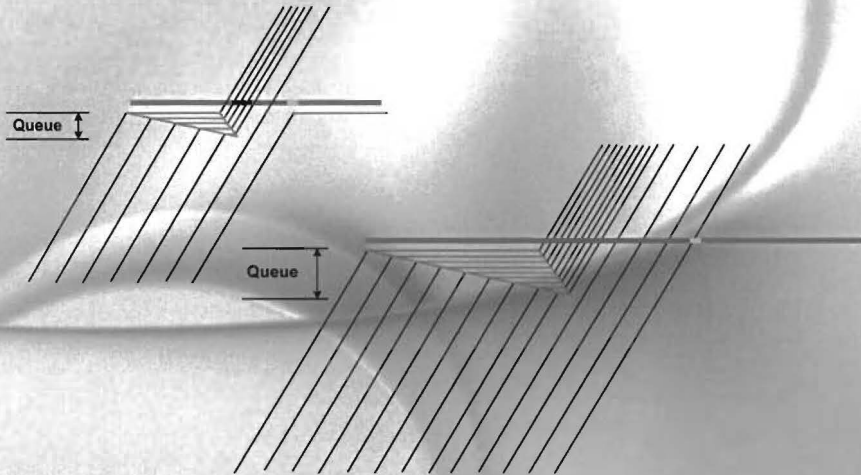

## *S2-Cycle Length vs. Delay*

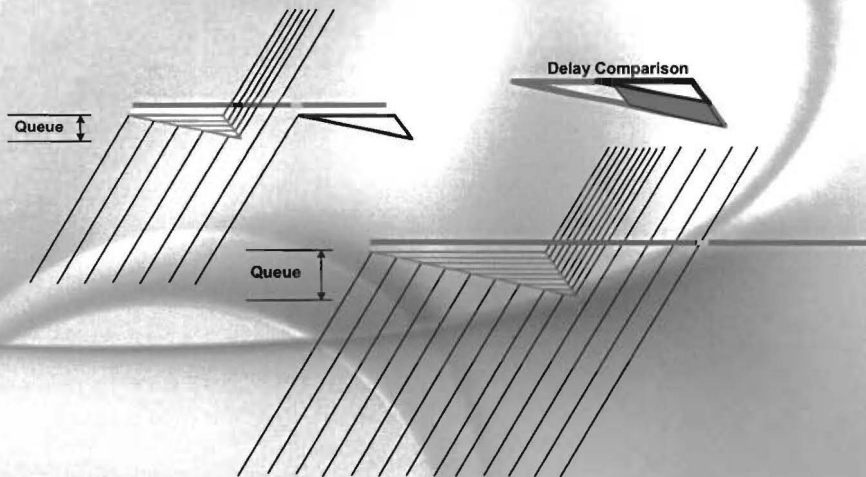

## ***S2–Timing Isolated Signals***

- **Select Best Timings**
  - ✓ **Cycle**
  - ✓ **Splits (or max, min, gap setting)**
  - ✓ **Clearance Intervals**
- **To provide**
  - ✓ **Safe**
  - ✓ **Efficient Operation**

## ***S2–Safety Issues***

- **Space Conflicts Inside Intersection**
  - ✓ **Use of Split Phasing**
- **Minimum Greens**
  - ✓ **Based on Driver Expectancy**
- **Vehicle Clearance Intervals**
- **Pedestrian Requirements**
- **Yellow Trap**

## S2 – Clearance Intervals

- Proper Settings Avoid a “Dilemma Zone”

Speed mph (kph)	Yellow Change sec (level grade)	+	Red Clearance sec (60' wide crossing)
25 (40)	2.84		2.18
35 (56)	3.57		1.55
45 (72)	4.31	+	1.21
55 (88)	5.04		0.99
65 (104)	5.78		0.84

## S2 – Pedestrians

$$G_p = (4 \text{ to } 7 \text{ seconds}) + \frac{\text{Distance}}{W}$$

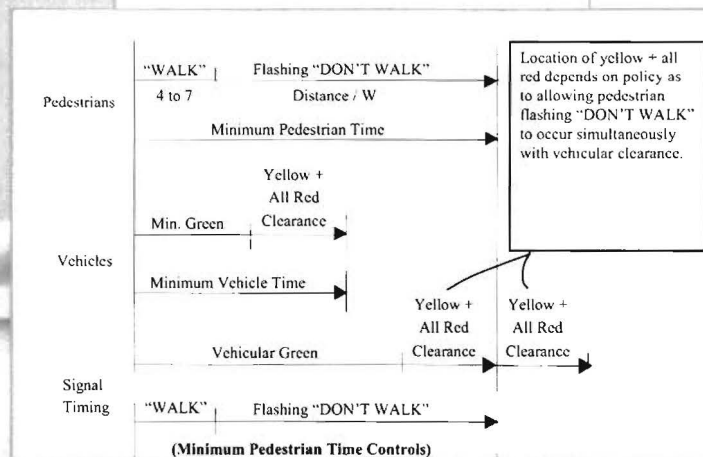

# S2 – Yellow Trap

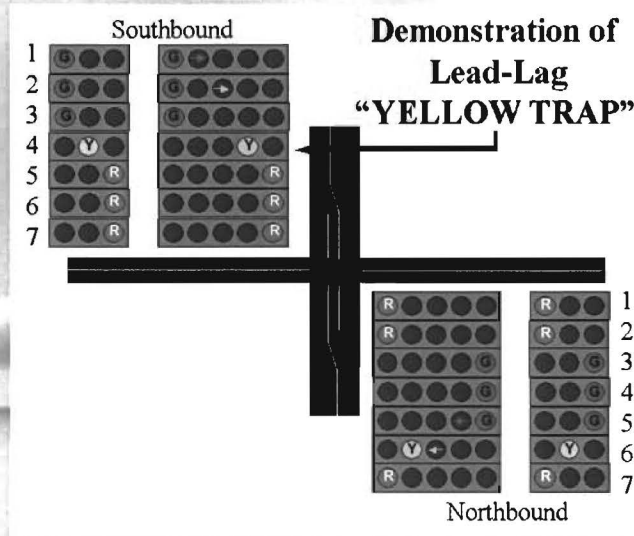

# S2 – Yellow Trap (continued)

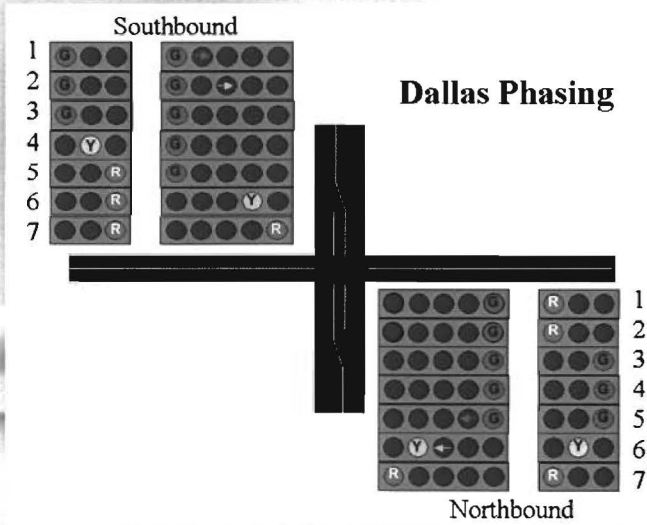

## ***S2–Best Isolated Operation***

- **What is Good Operation?**
  - ✓ **Minimum Delay**
  - ✓ **Shortest Queues per Cycle**
  - ✓ **Minimum Stops**
  - ✓ **Compromised Combination**
- **User Decides Based on Situation**
  - ✓ **Approach Speeds**
  - ✓ **Traffic Counts**
  - ✓ **Driver Perception**

## ***S2–PASSER V Data Needs***

- **Turning Movement Counts (TMC)**
  - ✓ **Collect 15-Minute Data and Calculate PHF**
  - ✓ **AM, PM, and Off-Peak**
  - ✓ **Collect Vehicle Mix Information**
- **Can Apply Growth Rates to Older Counts, as Long as Traffic Patterns Haven't Changed**



## ***S2–PASSER V Data Needs***

*(continued)*

- **Number of Lanes**
- **Lane Use**
- **Lane Widths**
- **Turn Bays and Lengths**

## ***S2–Input Considerations***

- **Left-turn Treatment**
  - ✓ **Number of Opposing Lanes**
  - ✓ **Overlapping Turning Paths (may need to split phase)**
  - ✓ **Type of Signal Heads (3, 4, or 5 Section)**
- **Pretimed, Semi-actuated, or Fully Actuated**
- **Priority or Preemption**

## ***S2–Performance Data***

- **Delay, Stops, Queue Information for Existing Conditions**
- **Collection Can Be Costly**

## ***S2–Isolated Signal Exercise***

- **Draw an Isolated Signal**
- **Enter Data**
- **Analyze**

# S2-NEMA Phase Numbering

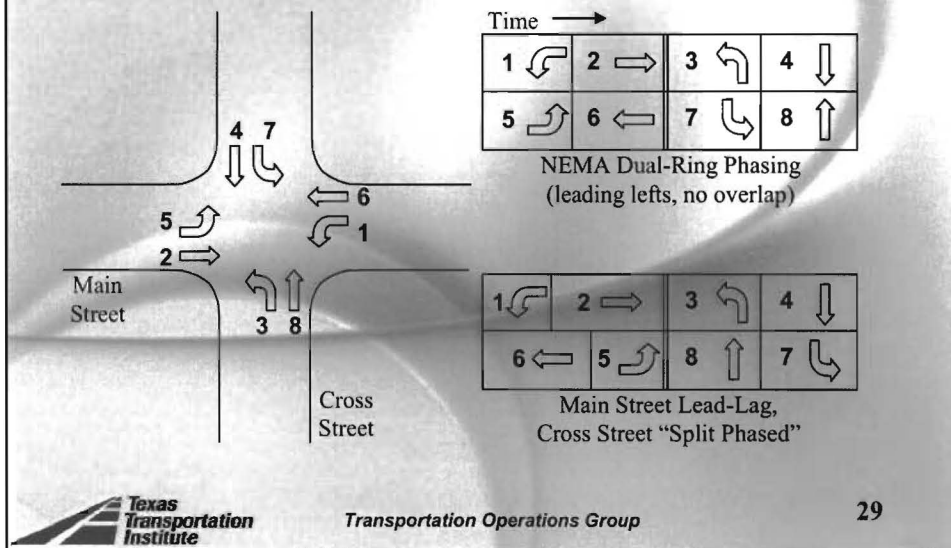

# S2-Intersection Data

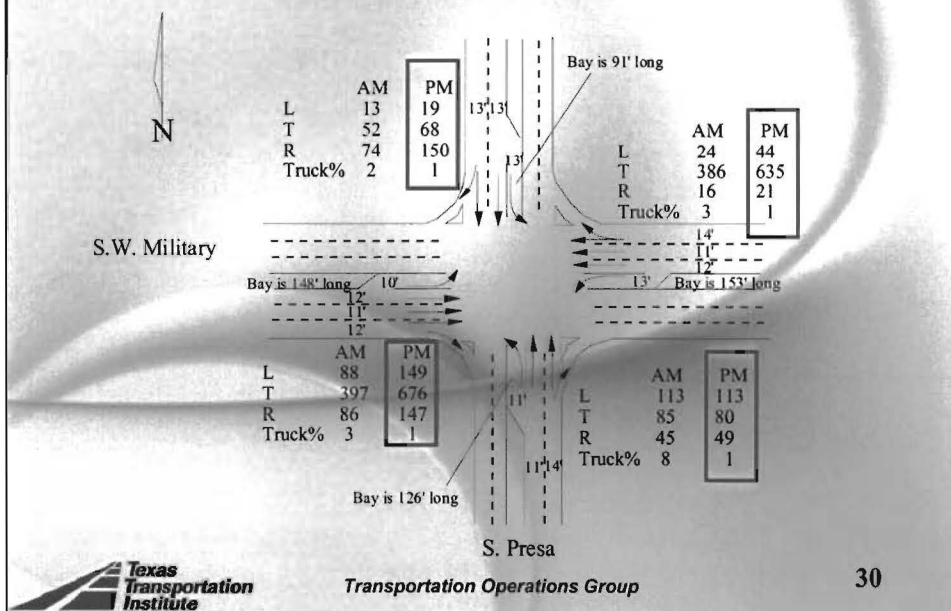



## ***S2–Data Entry***

- **Draw Links**
- **Define Lanes**
- **Enter PM-peak Volumes**
  - ✓ i.e., 149, 676, and 147 for EB
- **Select Movement Type**
  - ✓ EB and WB Prot (why?)
  - ✓ NB and SB Prot/Perm

## ***S2–Data Entry (continued)***

- **Adjust Right-turn Volumes for RTOR**
- **Overlap (Yes for lefts)**
- **Min Splits**
  - ✓ **Peds if No Buttons (Assumed)**
    - » NB:  $7 + (12+11+12+13+12+11+14)/4 = 28.25 \approx 29$  sec.
  - ✓ **EB, WB, NB, SB: 23, 23, 29, 29**
  - ✓ **Clearance Times**

## ***S2–Data Entry*** *(continued)*

- **Adjustments to Flows**
- **Trucks**
- **Ideal Saturation Flow**
- **Click Update Button**

## ***S2–Analysis/Results***

- **Delay vs. Cycle Analysis**
- **Controller: Ring-Barrier Display**
- **MOEs**

## ***Session 3: Signal Systems***

- **Overview:**
  - ✓ **Engineering Theory**
  - ✓ **Analysis Tools**

## ***S3–Flow Stability Between Adjacent Systems***

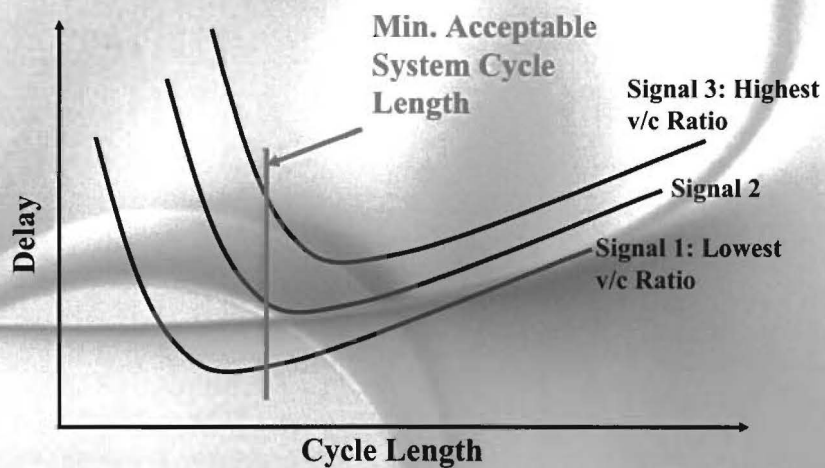

## ***S3–Signal Offset and Flow Between Adjacent Signals***

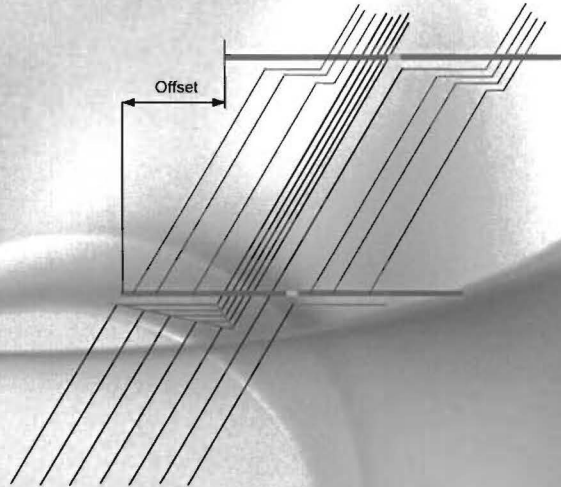

## ***S3–Flow vs. Bands***

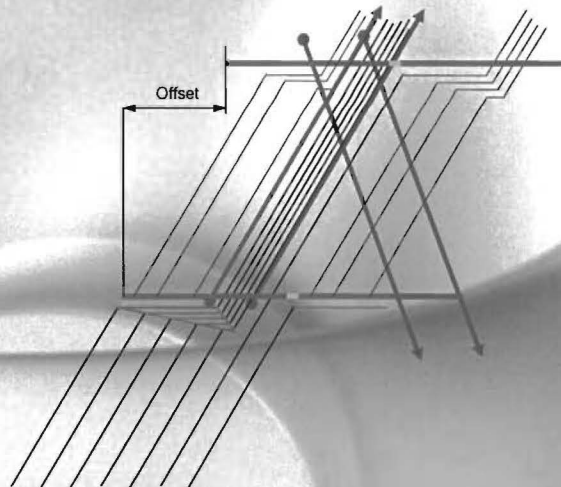

## ***S3–Effects of Changes in Offset***

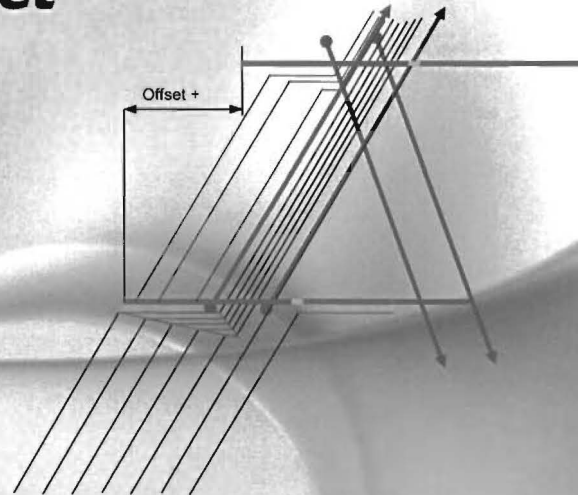

## ***S3–Cannot Get Two-way Bands? Change Phasing!***

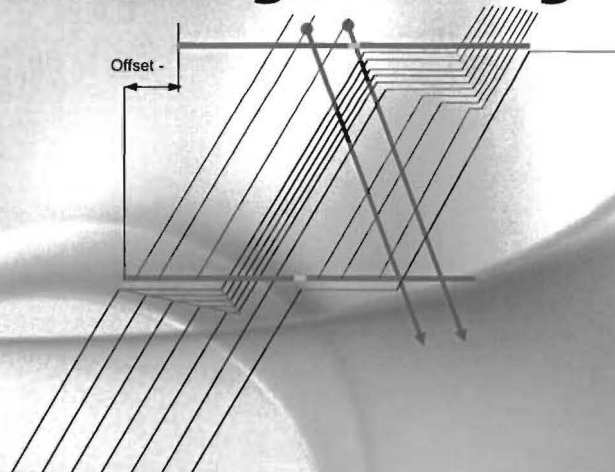

## ***S3–Changing Phasing Can Improve 2-way Progression***

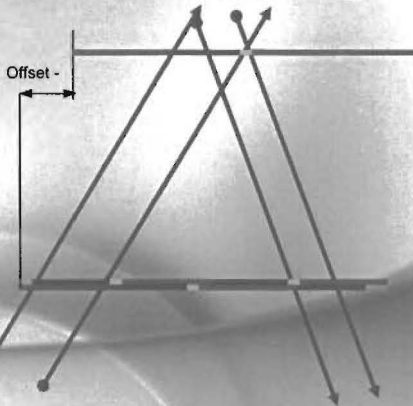

## ***S3–Timing Adjacent Signals***

### **• Objectives of Coordination**

- ✓ Provide/Maintain Safety
- ✓ Maintain Stable Flow
- ✓ Minimize Systemwide Delay
- ✓ Minimize Queues and Spillback
- ✓ Maximize System Throughput
- ✓ Minimize Number of Stops
- ✓ Maximize Arterial Progression

## ***S3–Types of Models***

- **Traffic Simulation Model**
  - ✓ **Evaluates a Specified Scenario**
  - ✓ **Generates Performance Measures**
- **Optimization Model**
  - ✓ **Systematically Generates Scenarios**
  - ✓ **Evaluates Using Simulation**
  - ✓ **Selects the Best Scenario**
  - ✓ **Usually Applicable to Traffic Signals**

## ***S3–Simulation Models***

- **Microscopic**
  - ✓ **Keeps Track of Each Vehicle**
  - ✓ **Time Consuming**
- **Mesoscopic**
  - ✓ **Analyzes Flow Profiles**
  - ✓ **Faster Calculations**
- **Macroscopic**
  - ✓ **Analyzes Platoons**
  - ✓ **Fastest Calculations**

## ***S3–Simulation Models*** *(continued)*

- **Microscopic**
  - ✓ **Keeps Track of Each Vehicle**
  - ✓ **Time Consuming**
- **Mesoscopic**
  - ✓ **Analyzes Flow Profiles**
  - ✓ **Faster Calculations**
- **Macroscopic**
  - ✓ **Analyzes Platoons**
  - ✓ **Fastest Calculations**
- **Stochastic**
- **Deterministic**

## ***S3–Simulation Accuracy***

- **Realistic Queues**
  - ✓ **Microscopic: CORSIM, Vissim, SimTraffic**
  - ✓ **Mesoscopic: new T7F, PASSER V, Synchro 6**
- **Upward Queue Stack**
  - ✓ **Mesoscopic: old T7F, S5 and P3**
  - ✓ **Macroscopic: P2, P4**

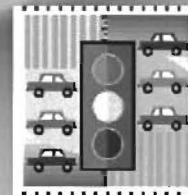
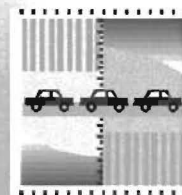



## ***S3–Spillback & Starvation***



## ***S3–Blocking and Starvation***

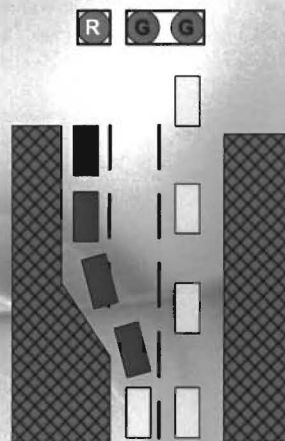

## ***S3–Blocking and Starvation*** *(continued)*

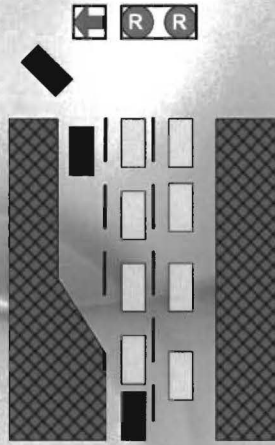

## ***S3–Starvation May Not Be Bad (Unused Capacity)***

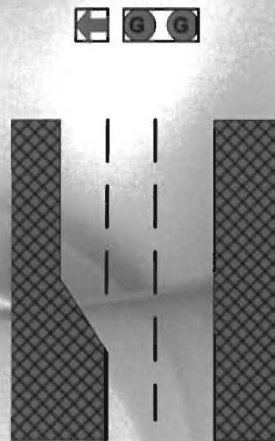

## ***S3–Optimization Criteria***

- **Maximize Arterial Progression**
- **Minimize Systemwide Delay**
- **Minimize Stops**
- **Minimize Queues**
- **Maximize Throughput**
- **Minimize Blocking and Spillback**

## ***S3–Optimization Methods***

- **Exhaustive Search**
- **Smart Search Techniques**
  - ✓ **Hill-climbing**
  - ✓ **Heuristic**
  - ✓ **Mathematical Programming**
  - ✓ **Genetic Algorithms**
- **Most Signal-Timing Programs Use a Combination**

## ***S3–Optimization Tool Types***

- **Delay-Based**

- ✓ **Minimizes Delay (+Qs and Stops)**

- ✓ **Evaluates/Simulates Each Plan**

- ✓ **Examples:**

- » TRANSYT 7F: Exhaustive, Hill-climbing, GA

- » Synchro: Exhaustive + Heuristic Search

- » PASSER III: Exhaustive Search

- » PASSER V: Exhaustive, GA

## ***S3–Optimization Tool Types***

*(continued)*

- **Bandwidth-Based**

- ✓ **Maximizes Arterial Progression**

- » Simple Objective Function

- ✓ **Simulates Traffic After Optimization**

- ✓ **Examples:**

- » PASSER II: Exhaustive and Heuristic

- » PASSER IV: Mathematical Programming

- » PASSER V: Exhaustive, Heuristic, GA

## ***S3-PASSER V Data Needs***

- **Signal Spacing**
- **Link Speeds**
- **Types of Link**

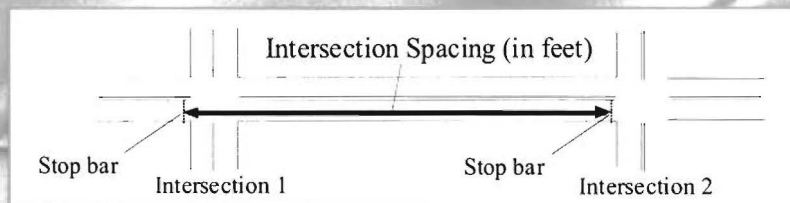

## ***S3-Input Performance Data***

- **Speed, Travel Time, or Delay Information for Existing Conditions**
- **May Need to Measure Speed for Use in PASSER V**
- **Can Be Used to Calibrate or Validate Your Base Model**
- **Collection Can Be Costly**

## ***Session 4: Diamond Interchange Analysis***

- **Background and Operational Issues**
- **Diamond Exercise**
  - ✓ **Create Interchange**
  - ✓ **Apply Optimization Tools and View Output**
    - » PASSER III
    - » GA-Based Optimizer
- **Apply Other Tools**
  - ✓ **Volume Analysis**
  - ✓ **Time-Space Diagram**
  - ✓ **Delay Analysis**

## ***S4–Background on Diamonds***

- **Two Closely Spaced Intersections**
- **Flow Characteristics Very Different from Arterials**
  - ✓ **Significant Turning Traffic**
- **Types**
  - ✓ **Conventional (More than 800 ft)**
  - ✓ **Compressed (400-800 ft)**
  - ✓ **Tight (Less than 400 ft)**

## ***S4–Background on Diamonds***

*(continued)*

- **Often Experience Operational Problems**
- **Capacity Dependent On**
  - ✓ **Splits at Both Intersections**
  - ✓ **Queuing and Spillback**
- **TxDOT/Texas Diamond Controller**
  - ✓ **Basic Three-Phase**
  - ✓ **TTI Four-Phase**
  - ✓ **Separate Intersection Mode**

## ***S4–NEMA Phase Numbering***

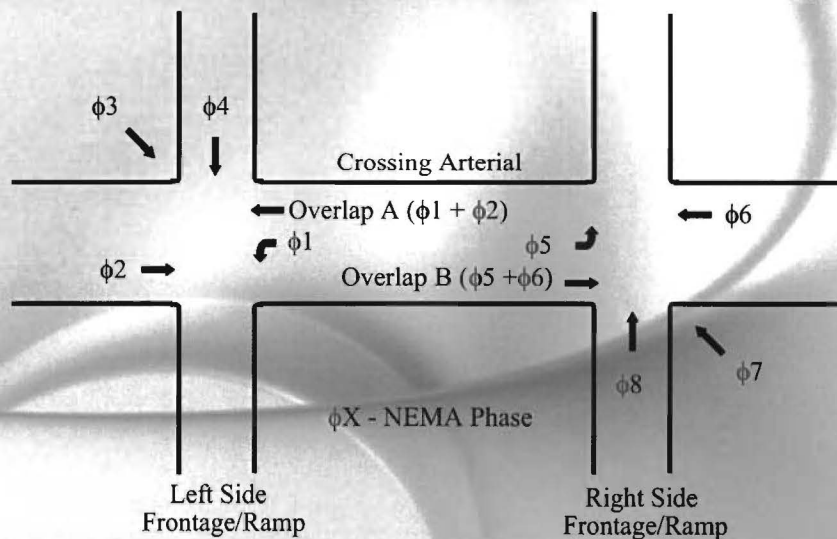

## S4-Three-Phase Operation

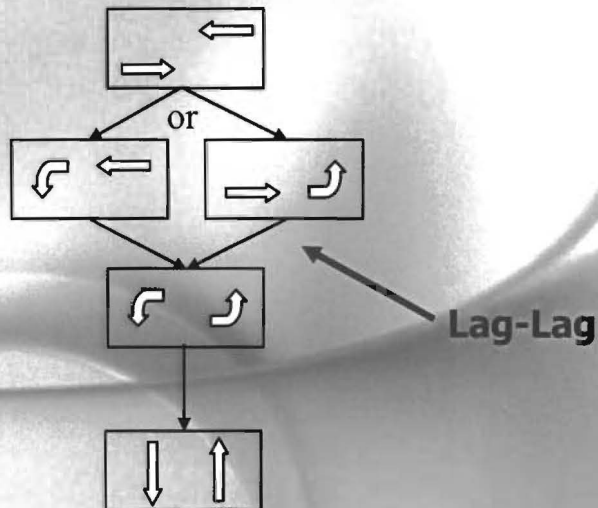

## S4-Four-Phase Operation

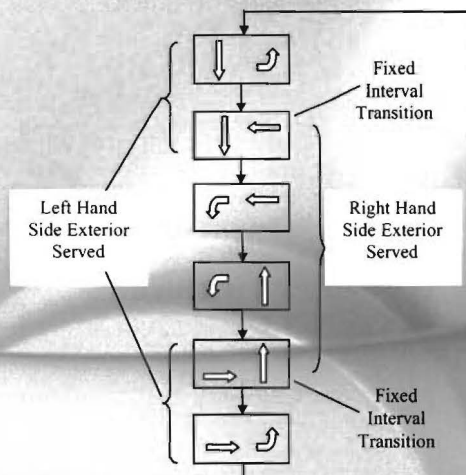

- **Lead-Lead Phasing**
- **Phase Times and Offset Calculated Simultaneously**
- **Needs Larger Cycle**



## ***S4–Other Options***

- **Separate Intersection Control Under Diamond Mode**
  - ✓ **Restricted to Lead-Lead Phasing**
  - ✓ **Can Provide Ring-lag/Offset**
- **User Programmed Mode**
  - ✓ **Difficult Programming**
  - ✓ **Flexibility of Operation**
- **Use Two Controllers**

## ***S4–Phasing Selection Guidelines***

- **Conventional Diamonds**
  - ✓ **Three-Phase**
  - ✓ **Four-Phase Not Recommended**
- **Compressed Diamonds**
  - ✓ **Three-Phase with Short Cycle**
  - ✓ **Four-Phase**
- **Tight Diamonds**
  - ✓ **Four-Phase**
  - ✓ **Three-Phase for Light Traffic**

## ***S4–Diamond Exercise***

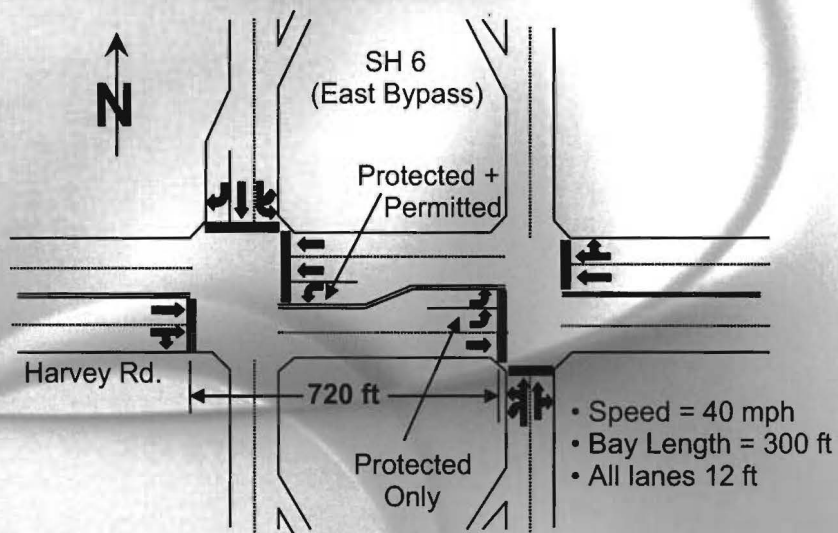

## ***S4–Data Entry/Analysis***

- **Draw Links/Define Interchange**
- **Load Data**
- **Select Tool and Analyze**
- **Review Results**

## ***S4-How GA Works***

- Randomly Generate Population
- Perform Reproduction Operation
  - ✓ Select Pairs/Parents, and Generate Offspring



- Evaluate Each Using Simulation
  - ✓ Note Population Has Doubled

## ***S4-How GA Works (continued)***

- Keep Best Half of New Population

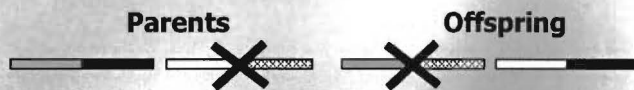

- Perform Mutation Operation



**Next  
Generation**

## ***S4–How GA Works*** *(continued)*

- **Stop If**
  - ✓ **No Improvement Possible or Maximum Generations Reached**
  - ✓ **Report the Best Plan**
- **Else**
  - ✓ **Repeat Process**

## ***S4–More Tools in PASSER V***

- **Volume Analysis**
- **Time-Space Diagram**
- **Delay Analysis**

# Session 5: Arterial Analysis

- **Arterial Exercise 1**
  - ✓ Load and Review Data
  - ✓ Apply Various Tools
  - ✓ Review/Interpret Output
- **Arterial Exercise 2**
  - ✓ Review Additional Features
    - » Creating and Working with Sub-nets
    - » Phasing Options
    - » Bandwidth-constrained Delay Minimization
    - » Adjusting Bands

# S5-Arterial Exercise 1

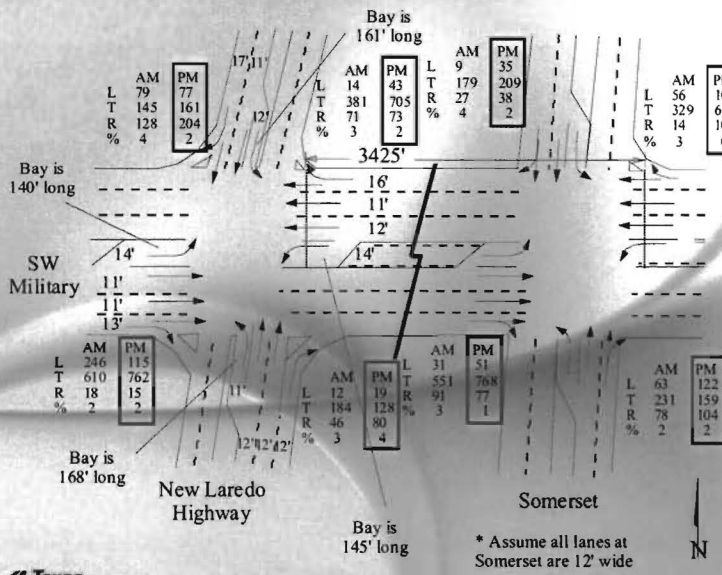

## S5-Arterial Exercise 2

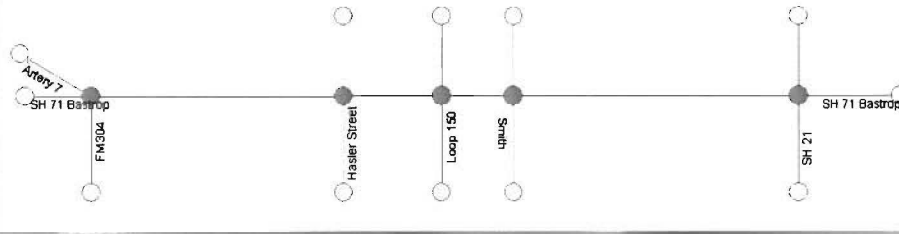

## S5-Band vs. Efficiency

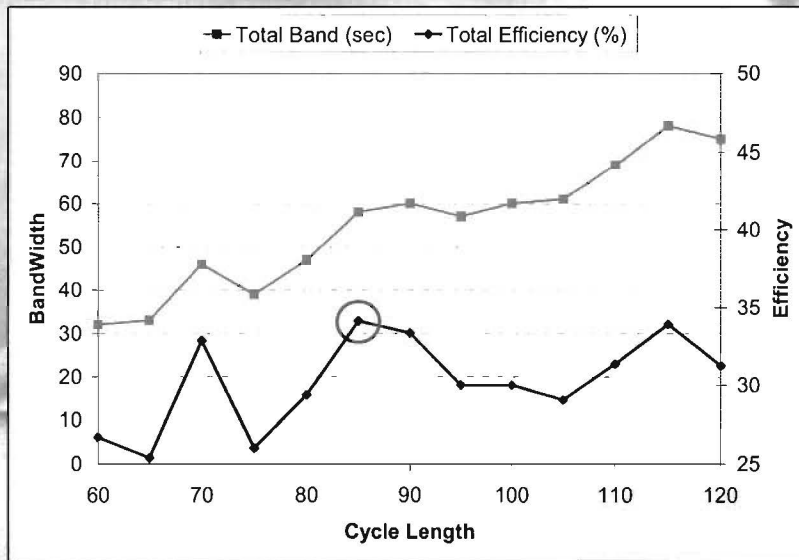

## S5-Delay and Attainability

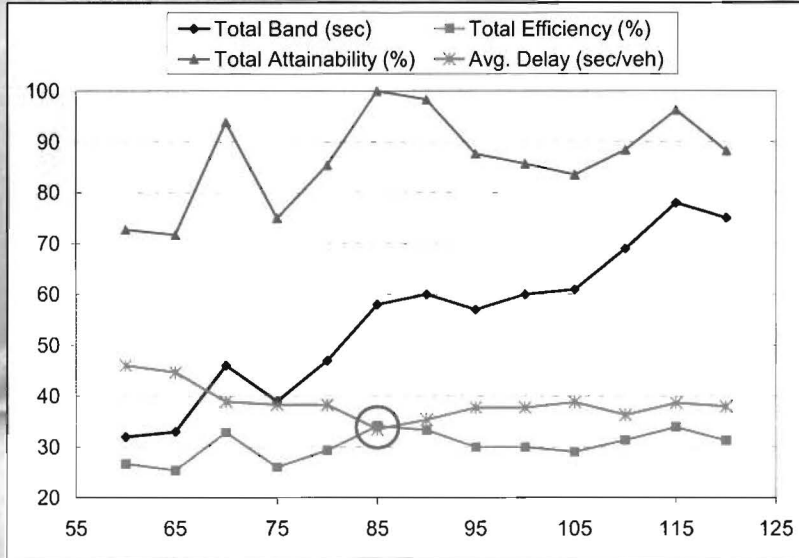

## S5-Tradeoffs in Performance

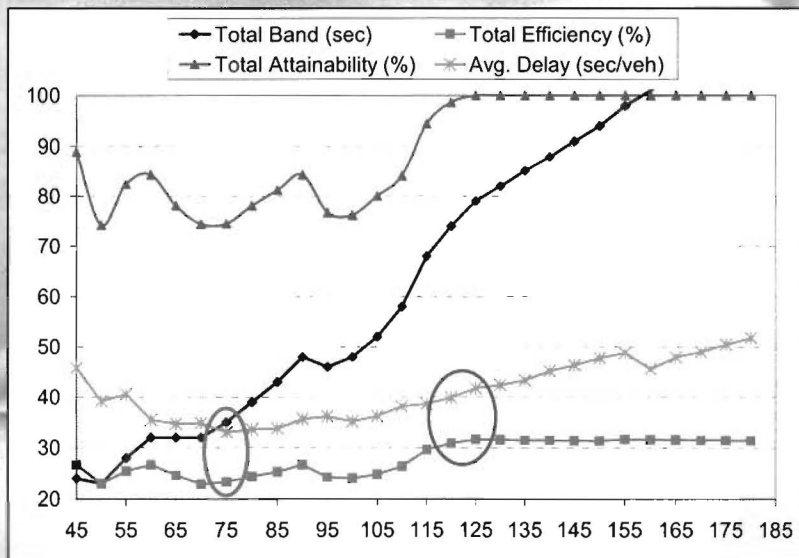

## ***Session 6: Diamond and Adjacent Signals***

- **Exercise Using Existing Data**
- **Apply Various Tools**
- **Review Output**

## ***S6-SH 195 Data***

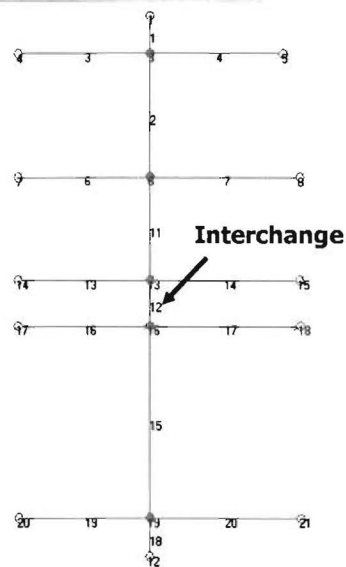



## ***Session 7: Workshop Conclusion***

- **Additional Topics and QA Session**
  - ✓ **Any Features Not Covered**
  - ✓ **Networks**
- **Survey**
  - ✓ **Tell Us How We Did**
  - ✓ **Feedback About PASSER V**

## ***TTI is Here to Help***

- **Nadeem Chaudhary**
  - ✓ **n-chaudhary@tamu.edu**
  - ✓ **(979) 845-9890**
- **Steve Venglar**
  - ✓ **s-venglar@tamu.edu**
  - ✓ **(512) 467-0946**
- **Chi-Leung Chu**
  - ✓ **clchu@tamu.edu**
  - ✓ **(979) 845-8408**

TEXAS TRANSPORTATION INSTITUTE

---

Transportation Operations Group



PASSER V



TRANSPORTATION OPERATIONS GROUP

# **PASSER V**

---

© Copyright 2004 by the Texas Transportation Institute  
Transportation Operations Group  
147 Gilchrist Bldg.  
College Station, Texas 77843-3135  
Phone (979) 845-9890 • Fax (979) 845-9873  
<http://ttisoftware.tamu.edu/>

# Disclaimer

The PASSER V program was developed under contract to the Texas Department of Transportation by the Texas Transportation Institute of the Texas A&M University System. It was designed for use by traffic engineers and other transportation professionals. Care should be taken to ensure the program package, which includes the user's documentation, remains intact. If the package elements become separated, program effectiveness may be impaired.

Be advised that no warranty is made by the Texas Department of Transportation, the Federal Highway Administration, the Texas Transportation Institute, or the Texas A&M University System as to the accuracy, completeness, reliability, usability, or suitability of the computer program discussed herein, this training guide, and/or their associated data and documentation. The guide, references to computer programs, and references to other literature are provided for purposes of training only. No responsibility is assumed by the above parties for the incorrect results or damages resulting from their use. All signal timing parameters entered into field devices must be examined and approved by a licensed professional engineer who is trained in the field of traffic engineering.

PASSER V software and related documentation are copyrighted. This software and documentation may not be copied or reproduced for commercial purposes. Modifications or alterations in the meaning, intent, applications, or operations of the software or documentation is absolutely prohibited unless prior approval has been obtained from the Texas Transportation Institute.

# Trademark

PASSER is a trademark of the Texas Transportation Institute. As such, any use of this trademark must have prior written approval from the Texas Transportation Institute.

©COPYRIGHT 2000, Texas Transportation Institute, All Rights Reserved.

Use of the PASSER trademark, software, or documentation in whole or part within the body of another work, except for brief citations, is prohibited. Selling or redistributing the PASSER trademark, software, or documentation by any person or agency other than the Texas Transportation Institute and its authorized agents is prohibited.

# Table of Contents

<b>CHAPTER 1 - TRAFFIC THEORY</b>		<b>Speed and Travel Time</b>	<b>55</b>
<b>Background</b>	<b>1</b>	<b>Additional Information</b>	<b>56</b>
<b>Intersection Configuration</b>	<b>1</b>	<b>CHAPTER 3 - PASSER V - 2003</b>	
<b>NEMA Phasing</b>	<b>2</b>	<b>Installing PASSER V</b>	<b>59</b>
<b>Interchange Phasing Strategies</b>	<b>4</b>	<b>Running PASSER V</b>	<b>60</b>
<b>Controller Types</b>	<b>7</b>	<b>File Menu Bar</b>	<b>60</b>
<b>Modes of Control</b>	<b>8</b>	<b>File Access Toolbar</b>	<b>61</b>
<b>Theory</b>	<b>9</b>	<b>PASSER V Function Toolbar</b>	<b>61</b>
<b>Saturation Flow Rate</b>	<b>10</b>	<b>CHAPTER 4 - ISOLATED INTERSECTION ANALYSIS</b>	
<b>Webster's Equation</b>	<b>10</b>	<b>Geometry Data Entry</b>	<b>73</b>
<b>Minimum Green Time</b>	<b>11</b>	<b>Volume Data Entry</b>	<b>78</b>
<b>Yellow Change + Red Clearance</b>	<b>13</b>	<b>Signal Settings Data Entry</b>	<b>80</b>
<b>Pedestrian Treatment</b>	<b>15</b>	<b>CHAPTER 5 - DIAMOND INTERCHANGE ANALYSIS</b>	
<b>Traffic Detection</b>	<b>17</b>	<b>Entering Data</b>	<b>90</b>
<b>Safety Considerations</b>	<b>20</b>	<b>Optimization</b>	<b>94</b>
<b>Analysis Tools</b>	<b>24</b>	<b>CHAPTER 6 - ARTERIAL ANALYSIS</b>	
<b>Traffic Signal Analysis Models</b>	<b>24</b>	<b>Entering Data</b>	<b>99</b>
<b>Optimization Models and Search Algorithms</b>	<b>26</b>	<b>Optimization</b>	<b>103</b>
<b>Popular Signal Timing Analysis and Optimization Programs</b>	<b>28</b>	<b>CHAPTER 7 - COMBINED ARTERIAL AND DIAMOND ANALYSIS</b>	
<b>PASSER V</b>	<b>30</b>	<b>An Example Problem</b>	<b>107</b>
<b>Optimization Algorithms in PASSER V</b>	<b>30</b>	<b>REFERENCES</b>	
<b>Analytical and Simulation Models</b>	<b>35</b>		<b>109</b>
<b>Optimization and Analysis Tools</b>	<b>44</b>		
<b>Program Limitations</b>	<b>46</b>		
<b>CHAPTER 2 - DATA REQUIREMENTS</b>			
<b>Traffic Volume Information</b>	<b>47</b>		
<b>Turning Movement Counts</b>	<b>47</b>		
<b>Average Daily Traffic</b>	<b>49</b>		
<b>Roadway Geometric Information</b>	<b>51</b>		
<b>Signal Timing Information</b>	<b>53</b>		
<b>Left-Turn Treatment</b>	<b>54</b>		
<b>Mode of Operation</b>	<b>54</b>		



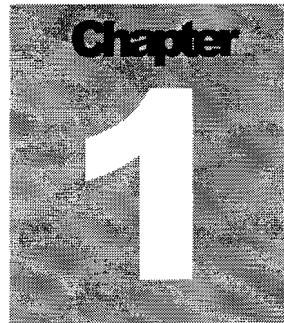

## Traffic Theory

*The gears that turn behind the scenes in your traffic optimization software.*

A course on signal optimization should not begin without a discussion of the theory behind the tools that are used for the analysis and optimization of signals along arterial roadways. Chapter 1 presents this information, along with a general discussion of the PASSER V-03 optimization tool. The chapter concludes with a presentation of the different types of traffic analysis software and how these tools are classified based on their features.

The materials for this course describe the procedural steps for using the PASSER V program to analyze intersections that:

- (1) have met the *Manual on Uniform Traffic Control Devices* (MUTCD) [1] traffic signal warrants and are being signalized for the first time; or
- (2) have previously been signalized and are currently operating in such a manner as to require signal timing modification or a combination of timing and geometric modifications.

### Background

This section presents uniform terminology that will be used throughout the course. Discussion items include intersection geometries, signal phasing nomenclature, controller types, and modes of intersection control operation.

### Intersection Configuration

The following figures represent very typical geometric configurations of signalized intersections.



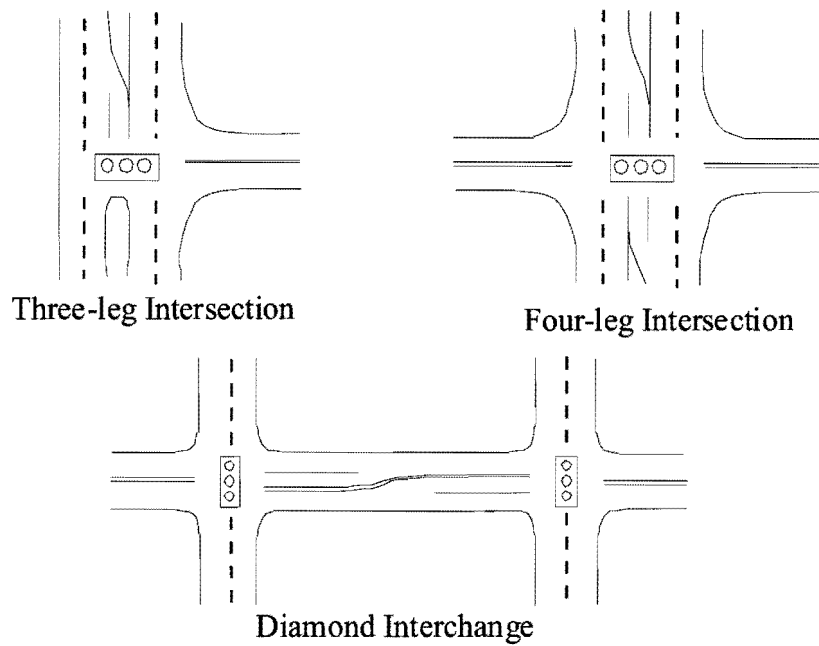

**NEMA Phasing**

The National Electrical Manufacturer’s Association (NEMA) defined a method for organizing phases in a dual-ring structure as part of its Traffic Signal 1 (TS1) standard [2]. The phasing reference scheme and the dual-ring concept are extremely versatile and powerful methods for depicting intersection phasing structure. Both are shown in the figure below.

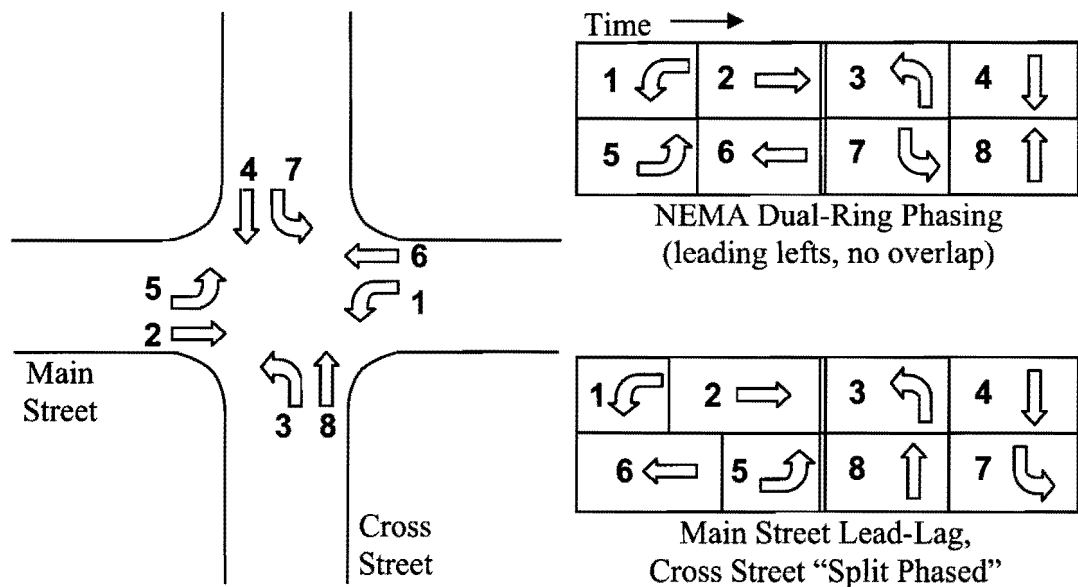

The NEMA phase reference system can be extended for use at a diamond interchange. The figure below shows a common representation of the phases at a diamond interchange using a NEMA-like phase numbering and reference system.

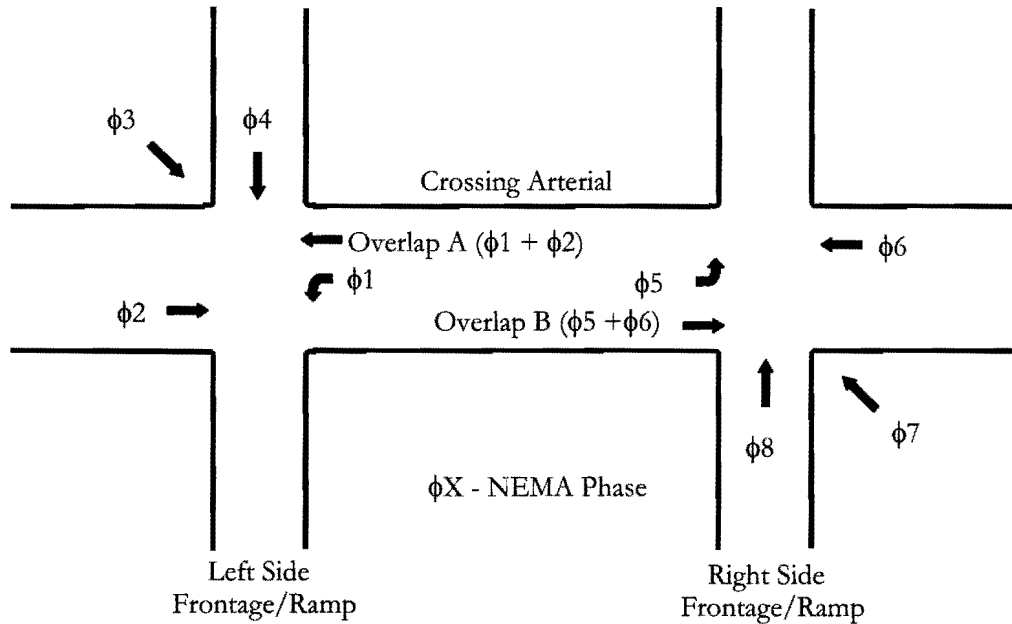

The number of intervals and the sequence of movements at the interchange determine the interchange phase pattern, or sequence. Phasing sequence names are linked to whether or not the interior left turn precedes, or leads, the opposing through movement on each side of the interchange. The four basic left-turn sequences are:

- **Lead-lead:** protected left-turn movements from the interior lanes lead the opposing arterial movement at both intersections.
- **Lead-lag:** protected left-turn movements from the interior lanes lead the opposing arterial movement at the left intersection and lag the opposing arterial phase at the right intersection.
- **Lag-lead:** the mirror image of the lead-lag phasing pattern.
- **Lag-lag:** protected left-turn movements from the interior lanes lag the opposing arterial movement at both intersections.

In addition to alternative phasing sequences, left-turn treatments at diamond interchanges also vary. The interior left-turn movements may be protected only, protected plus permitted, or permitted only (i.e., no left-turn phase). In the permitted only case, these phases would not exist (i.e., their duration would be set to zero) and the interchange would operate with only two timed phases. This alternative is desirable if a large number of acceptable gaps exist in the opposing traffic stream, and sight distance is adequate. By allowing permitted left turns, it is possible to reduce the overall delay of the interchange by reducing the number of phase changes required. Permitted left turns also increase the

potential capacity of the movement by increasing the time the movement is allowed to proceed through the intersection.

### **Interchange Phasing Strategies**

The basic diamond interchange strategies are two-phase, three-phase, and four-phase. Each of these strategies uses a different phasing structure to serve the traffic at the interchange. A discussion of the operation of each follows.

#### **Two-Phase**

Two-phase operation can be used at diamond interchanges operating under low traffic demands. The two phases from which the strategy derives its name are the arterial phase and the frontage road or ramp phase. In this strategy, the interior left-turn movements do not have a protected phase (i.e., a left-turn arrow), but proceed permissively during the arterial phase under a green ball indication.

Two-phase operation is beneficial when the left-turn and/or opposing through traffic volumes are light; however, sufficient sight distance **must** be available to the left-turning vehicles to determine whether it is safe to make the turn.

#### **Three-Phase**

For three-phase control, the three phases are the arterial phase, the ramp/frontage road phase, and the interior left-turn phase at each intersection. The two intersections can operate independently using coordination; or the intersections can be controlled by a single controller, thus providing a more defined relationship between the intersections. Protected only or protected plus permitted left-turn movements for the interior approaches are provided. In general, three-phase operation tends to produce less overall delay (compared to four-phase operation) when there is adequate space within the interchange interior to store queued vehicles. Three-phase operation is generally recommended for interchanges with moderate to high traffic volumes, wide spacing between the two intersections, and high through volumes on either the arterial or frontage road phases.

As discussed in the previous section, the three-phase strategy allows for varying left-turn sequences, including lead-lead, lead-lag, lag-lead, and lag-lag. In the lead-lag and lag-lead variations of three-phase operation, heavy left-turn traffic from the right or left frontage roads (respectively) is allowed to progress through the interchange. Variations of the three-phase timing patterns are shown in the next figure. All of the three-phase variations shown have no restrictions on when phases can begin and end with respect to one another – any of the three phases for the left intersection can occur, in part or whole, with any of the three phases for the right intersection.

Three-phase operation should generally be used when the diamond's intersections are spaced greater than 400 ft apart, or where the interior left-turn volumes of the interchange are low. With intersections spaced between 200 and 400 ft and balanced ramp traffic, three-phase or four-phase timing may be appropriate (discussed in the following section).

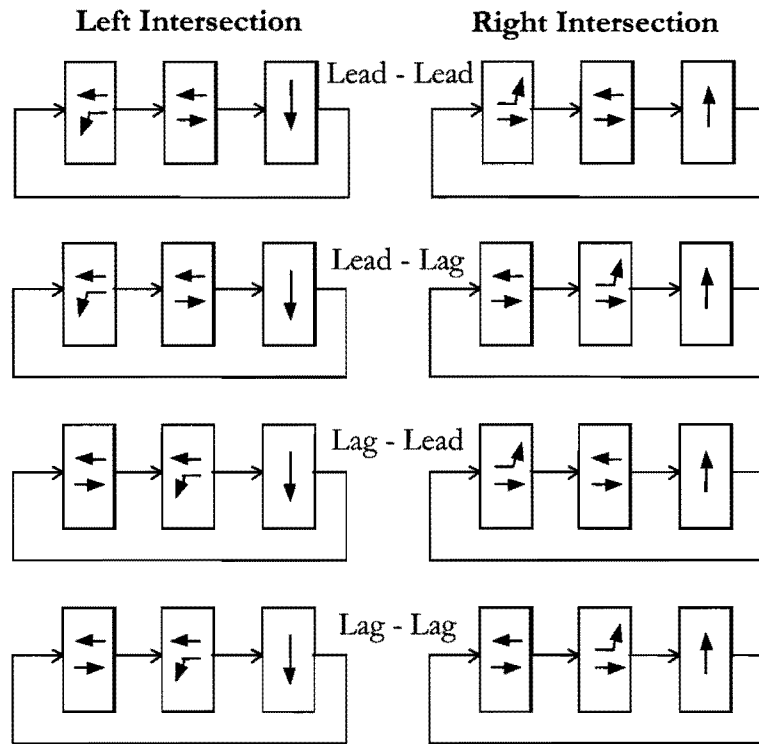

One form of three-phase timing, known as Basic three-phase, is defined as a lag-lag plan that has frontage road phases which are restricted to beginning and ending together. Extended three-phase operation is a form of Basic three-phase lag-lag operation wherein one frontage road movement is provided more time than the other. The next figure illustrates Basic and Extended three-phase diamond interchange operation.

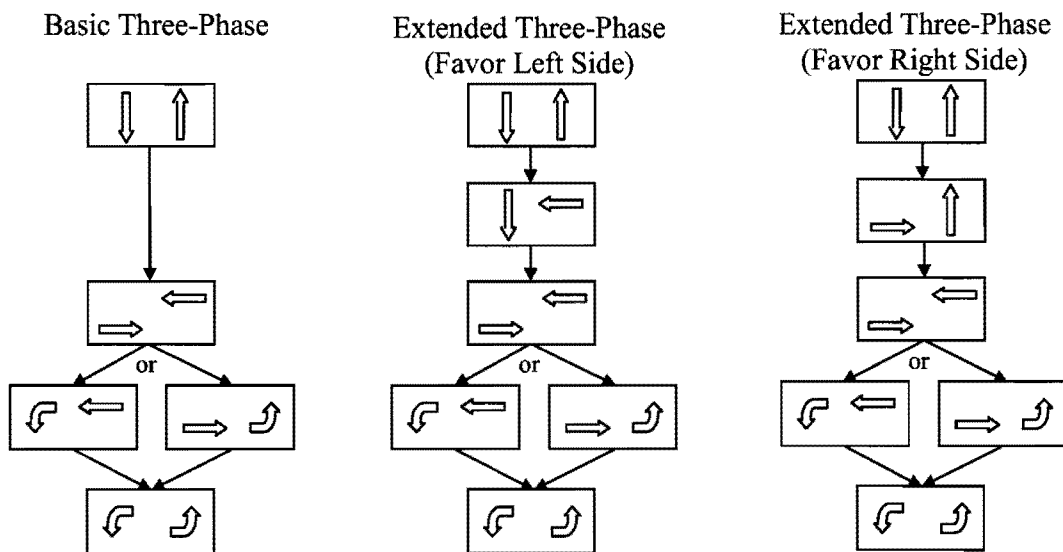

### Four-Phase

In four-phase control, the two intersections of the interchange are operationally treated like one large intersection. The four phases that give this plan its name are the two exterior arterial phases and the two exterior ramp/frontage road phases. Four-phase plans are known colloquially as either "TTI Lead" or "TTI four-phase." Protected left turns for the interior movements are provided. The duration of each interior phase is determined by subtracting the sum of the two exterior phase times at that intersection from the cycle length. This phasing pattern has become the preferred phasing plan for most diamond interchanges with close spacing (200 – 400 ft, depending on volume), and where interior turn volume intensity is high. With proper splits and offsets, it allows almost all traffic movements to progress through the interchange (with the exception of the fixed interval transition portion of interior left-turn phases for frontage road U-turns).

Four-phase operation is a lead-lead timing plan and commonly features two, fixed interval transitions (also known as "travel time intervals," "internal intervals" or "fixed time intervals," and in outdated terminology as "internal overlaps," "fixed overlaps," or "travel time overlaps"). These fixed interval transitions are related to the travel time between the two intersections. The fixed interval transitions occur when the external arterial movement entering one side of the interchange occurs simultaneously with the frontage road movement of the other side. The spacing of the interchange allows these movements to be timed together for a duration no greater than the travel time between the two intersections of the interchange.

Four-phase operation with two, fixed interval transition timing is common for interchanges with an intersection spacing of less than 200 ft and for interchanges with a spacing of between 200 and 400 ft that experience heavy, unbalanced ramp traffic. The phasing sequence is fixed by the strategy.

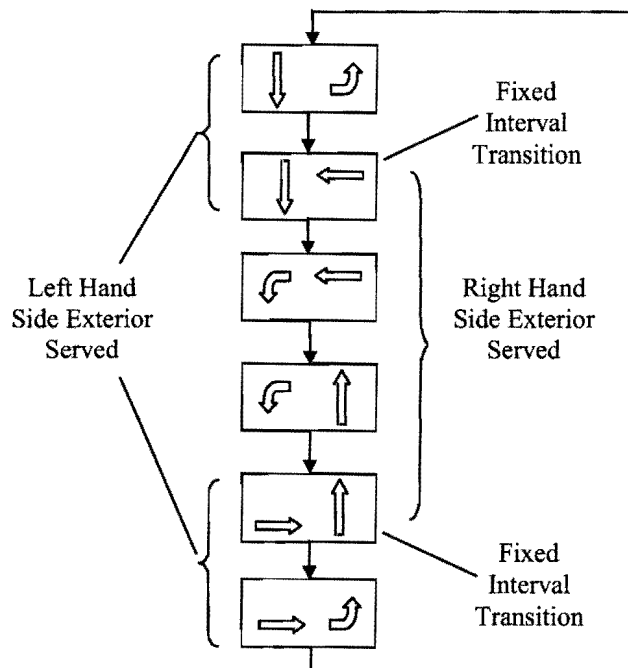

## Controller Types

As electronics and computer technologies have continued to evolve over time, these advancements have carried over into traffic signal controller technology to produce more reliable, flexible, and functional devices. Five general types of controllers are described below.

1. **Electromechanical.** These devices use synchronous motors and cams to open and close electronic circuits that govern the signal indications at an intersection. They are pin programmable for such variables as cycle length and phase split; they provide the engineer with the capability of changing cycle length, split, and offset (C/S/O); and they can accommodate changing C/S/O by time of day. Though electromechanical controllers can still be found in the field today, they should be considered technologically obsolete and replaced with modern, solid state controllers.
2. **Type 170.** 170 controllers are based on a hardware equipment specification jointly developed by the states of California and New York. Buying a Type 170 controller is like buying a personal computer – you get a standard piece of electronics, but you have to buy software to make it do something useful. Several national vendors provide a range of software for the 170. Type 170 controllers have proven extremely reliable and flexible over time, but the technology (i.e., eight-bit microprocessor) is over 20 years old. Some vendors offer updated programmable read-only memory (PROM) cards for the 170 that add more memory (i.e., more timing plans, more functions) and newer processors with the simple exchange of a circuit board plug-in module.
3. **NEMA TS1 and TS2.** The NEMA TS1 standard came about roughly in the same time frame as the original Type 170 specification. Unlike the 170 specification, the TS1 standard defined the functionality (i.e., what the controller device was supposed to do and what features it was required to have) of the controller device rather than the equipment. The TS1 also standardized cabinet wiring and harnesses, added a conflict monitor (i.e., a cabinet “watchdog” device), and developed a uniform phase reference. NEMA TS1 compatible controllers have evolved over time because manufacturers were able to use new microprocessors and expanded memory to fulfill TS1 functional requirements, and each manufacturer was able to add additional functionality (i.e., closed loop system) to make their products more marketable. Unfortunately, each manufacturer pursued functionality outside of the TS1 standard differently, and this “higher tier” of functionality is not compatible across manufacturers. The TS2 standard [3] is a major leap in the modernization of the TS1 for current electronics technology. Cabinet communications no longer take place using discrete electronic signals over hundreds of wires, but over a communications bus. The conflict monitor of the TS1 has been replaced by a much more powerful programmable malfunction management unit, and detection, coordination, and preemption capabilities have been enhanced.
4. **Texas Diamond Controller.** The State of Texas has continuous frontage roads along most of its interstate and urban freeway mileage. Because of this roadway feature, the

diamond interchange is a popular interchange treatment for junctions of grade-separated facilities with major and minor arterials. To cope with operating the many interchange geometries and signal orientations at these crossings, the Texas Department of Transportation (TxDOT) developed a specification [4] for a signal controller device that was capable of operating in two of the most versatile phasing sequences common at diamond interchanges. Controllers that meet the TxDOT Diamond Specification are programmed with settings for operation in the Basic three-phase, lag-lag pattern and the TTI four-phase strategy.

5. **Advanced Traffic Controller (ATC), Type 2070.** Like the Type 170, the 2070 is a specification for a piece of electronic equipment. Unlike the 170, the 2070 is an open architecture device that has expansion bays for adding processing power and memory for device functionality that can pass far beyond simple traffic control. Third party software must still be purchased to run on the 2070 in order to provide traffic control functions. However, additional cards can be added to the 2070 to accomplish any number of objectives, including ramp metering control, video camera control and detection, changeable message sign control, etc. The 2070 is also envisioned as a device that will make use of the National Transportation Communications for ITS Protocol (NTCIP) so that devices from multiple manufacturers are 100 percent compatible with one another in terms of device-to-device communications.

### **Modes of Control**

All modern controllers are capable of operating in one of three modes: pretimed, semi-actuated, or fully actuated. Choice of mode is dependent on a variety of considerations, including availability of communications infrastructure (wireline or wireless), traffic flow characteristics at the site, intersection spacing, detector placement, and detector maintenance. Discussed below are descriptions, conditions for application, and common examples of each mode of controller operation.

1. **Pretimed.** As the name implies, pretimed control is fixed in terms of cycle length and phase split. Once programmed, the same order and duration of phase indications will occur at the intersection until the controller settings are manually reprogrammed, or another set of fixed duration settings is selected by time-of-day or day-of-week/month/year. This mode is not traffic responsive (i.e., uses no detectors), but it can be used in coordinated systems along arterials or in network systems. One common system application of pretimed controllers is in a closed loop system that does not use detectors. Pretimed operation tends to be most effective where there is little or no traffic growth and traffic patterns are regular and predictable. Downtowns and smaller towns not experiencing growth are typical locations for effective pretimed operation.
2. **Semi-actuated.** Semi-actuated, or coordinated actuated, operation uses detectors on non-coordinated phases to offer more flexible use of green time than is possible in pretimed operation. A fixed cycle length is still in force and the main street's through movements are also "fixed" with respect to when they must be present in the background cycle. However, the main street's left-turn phases and the crossing street's

through and left-turn phases can all be skipped, shortened, or lengthened in comparison to pretimed operation, depending on demand. Unfortunately, this added degree of freedom in managing green time is obtained by the use of detectors, which must be installed, wired back to the cabinet, and maintained. Semi-actuated operation along an arterial roadway managed by a closed loop system and monitored by agency staff is a practical goal for state-of-the-practice signal control. Semi-actuated operation is most appropriate along arterials that have a high volume with respect to crossing roadways. Moderate changes in volume and traffic flow pattern are easily accommodated.

3. **Fully Actuated.** Intersections operating in fully actuated mode have no background cycle length. Phase durations (splits) are determined by the number of vehicles that pass through the detection zones of traffic detectors. A minimum and maximum time are set for each phase. The first vehicle in the queue (at the stop bar) guarantees that the minimum time will be given to the phase. Subsequent detections extend the phase for a given amount of time up until the maximum, where green will go to the next conflicting phase that has a detector call. If the maximum time is reached and no vehicles are waiting on conflicting phases, green remains on the first phase (i.e., past the maximum time) until a detection on another phase occurs. One critical aspect of fully actuated operation is the maintenance of detectors – if the detectors do not work, green time does not show on phases where vehicles are waiting and drivers become frustrated. This mode is appropriate where traffic volumes and patterns are reasonably to highly variable, where intersections are isolated (i.e., far away from other signalized intersections), or where volumes are light and quick response to a vehicle detection is desired.

Diamond interchanges operating in fully actuated mode also have no background cycle length. In fact, one of the advantages of a single controller for diamond interchanges is the ability to operate in a fully actuated mode, without the need for a background cycle length. Fully actuated traffic control is more adaptable to the traffic conditions that exist. Actuated controllers are able to adjust phase lengths based on the traffic demand that is sensed by detectors. Detectors such as inductive loops or video imaging systems communicate the status of the detector to the controller, and logic within the controller determines whether to continue the phase or reduce the time allotted to that particular phase. Detection systems and detector locations for the interchange can vary based on the type of phasing [5].

## Theory

Traffic engineering theory supports the methods and procedures for all traffic engineering analysis software. The Highway Capacity Software (HCS), for instance, is a software encoded version of the major analysis procedures described in the *Highway Capacity Manual* (HCM) [6]. PASSER V incorporates a range of traffic engineering, optimization, and queuing theories. Basic elements and definitions, taken from the *Traffic Engineering Handbook* [7] and *Traffic Engineering* [8], are presented here to assist in understanding the PASSER V program.



### Saturation Flow Rate

One of the most fundamental aspects of traffic engineering is the response to the question, “How much traffic can this road accommodate?” The saturation flow rate defines the amount of traffic flow that can travel past a point in vehicles per hour green (vphg). The ideal rate is up to the analyst and depends on local driver behavior, but a rate of 1900 pcphgpl (passenger cars per hour green per lane) is common. The ideal rate is reduced based on local conditions, which are accounted for by the use of factors. The overall equation is:

$$s = s_o N f_w f_{HV} f_g f_p f_{bb} f_a f_{LU} f_{LT} f_{RT} f_{Lpb} f_{Rpb}$$

where:	$s$	=	actual saturation flow rate for lane group, in vphg
	$s_o$	=	ideal saturation flow rate per lane, usually 2000 – 2200 pcphgpl
	$N$	=	number of lanes in the lane group
	$f_w$	=	adjustment factor for lane width
	$f_{HV}$	=	adjustment factor for heavy vehicles
	$f_g$	=	adjustment factor for grade
	$f_p$	=	adjustment factor for adjacent parking lane and parking activity
	$f_{bb}$	=	adjustment factor for local bus stopping
	$f_a$	=	adjustment factor for area type
	$f_{LU}$	=	adjustment factor for lane utilization
	$f_{LT}$	=	adjustment factor for left turns in lane group
	$f_{RT}$	=	adjustment factor for right turns in lane group
	$f_{Lpb}$	=	pedestrian-bicycle adjustment factor for left turns
	$f_{Rpb}$	=	pedestrian-bicycle adjustment factor for right turns

The HCM [6] is the primary source for information about saturation flow rate adjustment factors.

**Key Point:** The calculation of appropriate saturation flow rates is essential to performing an analysis that will produce reliable results. Saturation flow rates are a key element of most manual and computerized forms of traffic engineering analyses, including PASSER V.

### Webster's Equation

F.V. Webster developed an equation that approximates the minimum delay cycle length for an intersection.

$$C_0 = \frac{1.5L + 5}{1.0 - Y_1 - Y_2 - \dots - Y_n}$$

- where:  $C_0$  = optimum cycle length in seconds  
 $L$  = lost time per cycle, generally the sum of the total yellow and all red clearance per cycle, in seconds  
 $Y_i$  = volume divided by saturation flow for the critical approach in phase  $i$   
 $n$  = subscript for each phase

The figure below, reproduced from the *Traffic Engineering Handbook* [7], highlights an essential result that is derived from the use of Webster's equation.

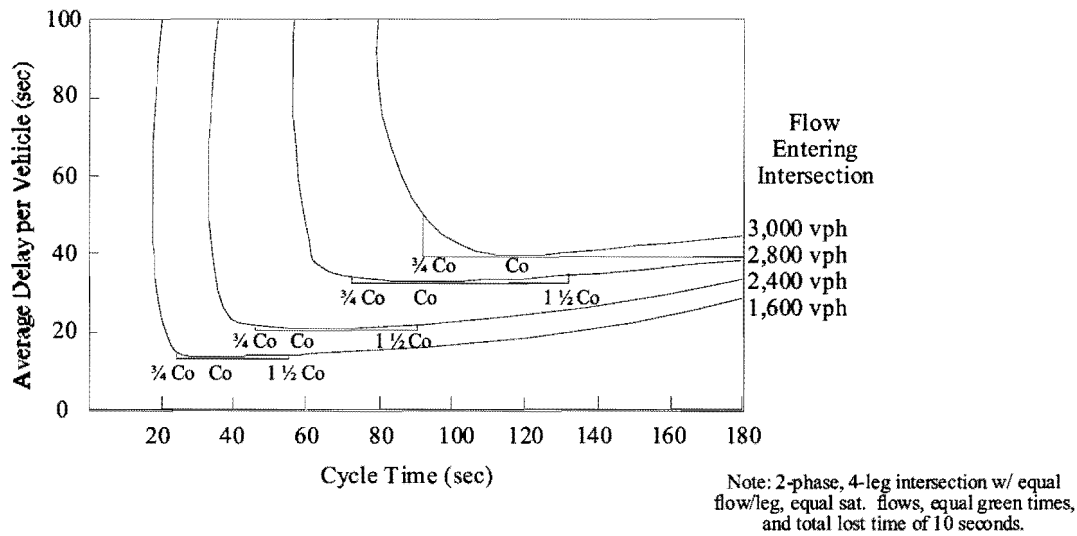

**Key Point:** A range of cycle lengths will produce good intersection operations; the flexibility provided by the range can be used to provide extra green time to left turns or critical through movements.

### Minimum Green Time

In either pretimed, semi-actuated, or actuated mode of operation, each phase at an intersection or a diamond interchange must be programmed with a minimum green time. The minimum time is determined based on a number of considerations, including the mode of controller and phase operation, the presence and location of detectors on the approach served by the phase, and the responsiveness of motorists using the facility.

In pretimed operation in its most simple form, the minimum green time and maximum green time for each phase can be set to the same value to guarantee the display of a phase of uniform length from cycle to cycle. In these cases, the minimum green is based on the timing requirements for the maximum green time (i.e., the traffic demand using the phase,

pedestrian times, and phasing requirements for all phases). However, it must be pointed out that setting the minimum and maximum green times to the same values eliminates phasing flexibility. A preferred method for establishing pretimed control is to set the minimum green time accordingly to normal agency practices and set the maximum time (Max 1) equal to the desired duration of the green time portion for each phase. Then, the phase is set to maximum recall (recall to max. green time) and, along with all other phases set the same way, constitutes the pretimed cycle length. This operation allows flexibility since the maximum can be changed easily as the peak/off-peak timing plan changes, and the alternate maximum time (Max 2) can be called by time of day for phase time adjustments if necessary.

For actuated control (and this should be checked for pretimed operation as well), the minimum green time will always have a lower bound. It must be at least sufficiently long to allow motorists to recognize that the signal has gone to green and begin responding to the green signal indication (i.e., remove brake and begin accelerating). Minimum green times are governed by the practices of the responsible agency, but usually vary from 5 to 7 seconds.

Controllers operating in either semi-actuated or fully actuated mode make more direct use of the minimum green time programmed into the controller for each phase. In either of these actuated modes, the minimum green time is the minimum length of time that a green indication will be displayed for each phase. The duration of the minimum green is usually based on the location of the detectors that service the phase, where the minimum green is adequate to serve all vehicles located between the stop bar and the detector location (which is usually set back from the intersection/stop bar). Some controller devices also offer variable initial (i.e., variable minimum green), which bases the duration of the minimum green on the amount of green time required to serve the number of vehicles that have crossed the detector before that phase becomes green. When variable initial is used, there is an absolute minimum green which must remain present, but the minimum green time can be extended up to the maximum initial (i.e., longest minimum green time).

Minimum green times are an especially important consideration at diamond interchanges because of phasing complexity and controller programming required to ensure proper and appropriate operation. Some diamond interchange phasing sequences, especially TTI four-phase operation, require that multiple phases be used to serve some (or perhaps, all, depending on controller configuration) interchange traffic movements. This is accomplished by using overlaps, which allow multiple phases to cause a green indication to be displayed for the traffic movement for which the overlap is programmed. The overlap will maintain a green indication for a movement during the green time, yellow change interval, and red clearance interval of the first serviced phase within the overlap if the following phase(s) are also programmed to be a part of the overlap. However, in all diamond phasing sequences that operate in semi-actuated and/or fully actuated mode, it may be possible to skip any or all of the phases programmed to be part of the overlap. Thus, it is critical that each phase, whether it is part of an overlap or not, be programmed with adequate minimum green time, yellow change interval, and red clearance interval for the appropriate approach and movement. In practical implementation, this may mean that the interchange's cycle length must be lengthened slightly to provide all phases with a

minimum green and clearance times. When implementing output and timing recommendations from the PASSER V-03 program, it may be necessary to extend certain phase times (and, thus the cycle length) to ensure that all phases (whether they compose an overlap or not) are provided with adequate and appropriate minimum green times, yellow change intervals, and red clearance intervals.

### Yellow Change + Red Clearance

Phase termination before the start of a conflicting phase is always accomplished using a transition period that is composed of the yellow change interval plus the red clearance interval. Different agencies have different rules governing how these periods are computed, and in some cases all red clearance times are set to zero. NEMA also influences phasing behavior within controller devices that meet its standard by requiring that all phases have a yellow change interval of at least 3 seconds [2]. The following equations from the *Traffic Engineering Handbook* [7] present means for computing the yellow change and red clearance times, respectively.

$$y = t + \frac{v}{2a + 2Gg} \quad 1)$$

- where:  $y$  = length of the yellow interval, to the nearest 0.1 second  
 $t$  = driver perception/reaction time, recommended as 1.0 second  
 $v$  = velocity of approaching vehicle, in feet/second  
 $a$  = deceleration rate, recommended as 10 feet/second<sup>2</sup>  
 $G$  = acceleration due to gravity, 32 feet/second<sup>2</sup>  
 $g$  = grade of approach, decimal format (0.02 for 2%, downhill is negative)

$$r = \frac{W + L}{V} \quad 2)$$

$$r = \frac{P}{V} \quad 3)$$

$$r = \frac{P + L}{V} \quad 4)$$

- where:  $r$  = length of red clearance interval, to the nearest 0.1 second  
 $W$  = width of intersection, in feet, measured from the near-side stop line to the far edge of the conflicting traffic lane along the vehicle path  
 $P$  = width of intersection, in feet, measured from the near-side stop line to the far side of the farthest conflicting pedestrian crosswalk along the actual vehicle path  
 $L$  = length of vehicle, recommended as 20 feet  
 $V$  = speed of vehicle through the intersection, in feet/second

Red clearance equations depend on the type of application, where the *Traffic Engineering Handbook* [7] states that it is recommended to use Equation 2 where there are no pedestrians. Equation 3 or 4 (whichever is longer) is used where there is the probability of pedestrians crossing, and Equation 4 where there is significant pedestrian traffic or pedestrian signals that protect the crosswalk.

Appropriate detector placement combined with appropriate yellow and the red clearance time ensures that motorists are not trapped in a “dilemma zone.” The dilemma zone is a point where a driver cannot stop at a reasonable rate of deceleration and where the same driver cannot pass through the intersection within the yellow time allotted. The red clearance interval is primarily a tool to avoid displaying unusually long yellow times. For more information, see *Traffic Engineering* [8].

The following tables, reproduced from an Institute of Transportation Engineers informational report [9], provide yellow change intervals and red clearance intervals for various combinations of speed, grade, and intersection approach width. Note that a red clearance interval may be used to meet the required time shown in the first table when the maximum length of the yellow change interval is set at 5.0 seconds.

**Yellow Change Interval Lengths (in seconds)**

85 <sup>th</sup> Percentile Speed mph (km/h)	Grade of Approach								
	Uphill				Level	Downhill			
	+4%	+3%	+2%	+1%		-1%	-2%	-3%	-4%
25 (40)	2.63	2.68	2.73	2.78	2.84	2.90	2.96	3.03	3.11
35 (56)	3.28	3.35	3.42	3.49	3.57	3.56	3.75	3.85	3.95
45 (72)	3.93	4.02	4.11	4.20	4.31	4.42	4.54	4.66	4.80
55 (88)	4.58	4.69	4.80	4.92	5.04	5.18	5.32	5.47	5.64
65 (104)	5.23	5.35	5.49	5.63	5.78	5.94	6.11	6.29	6.48

**Red Clearance Interval Lengths Using Equation 2 (in seconds)**

85 <sup>th</sup> Percentile Speed mph (km/h)	Width of Approach Feet (meters)										
	20 (6)	30 (9)	40 (12)	50 (15)	60 (18)	70 (21)	80 (24)	90 (27)	100 (30)	110 (33)	120 (36)
25 (40)	1.09	1.36	1.63	1.90	2.18	2.45	2.72	2.99	3.27	3.54	3.81
35 (56)	0.78	0.97	1.17	1.36	1.55	1.75	1.94	2.14	2.33	2.53	2.72
45 (72)	0.60	0.76	0.91	1.06	1.21	1.35	1.51	1.66	1.81	1.97	2.12
55 (88)	0.49	0.62	0.74	0.87	0.99	1.11	1.24	1.36	1.48	1.61	1.73
65 (104)	0.42	0.52	0.63	0.73	0.84	0.94	1.05	1.15	1.26	1.36	1.47

**Key Point:** Combining the equation for yellow change interval and the appropriate equation for red clearance time (see discussion) ensures that motorists are not trapped in a “dilemma zone.” The dilemma zone is defined as a point where a driver cannot stop at a reasonable rate of deceleration and where the same driver cannot pass through the intersection within the yellow time allotted. The use of the red clearance interval is primarily a tool to avoid displaying unusually long yellow times. For more information, see *Traffic Engineering* [8].

### Pedestrian Treatment

The MUTCD [1] states that under normal conditions the WALK interval should be at least 7 seconds. In addition, the MUTCD indicates that the minimum pedestrian walking distance to be used in computing pedestrian green requirements is the curb to curb distance beyond the farthest traveled lane (see distance  $D_4$  in the figure below). The distance pedestrians must travel to cross the intersection is the main criteria for selection of a minimum pedestrian time at the intersection. The figure shows the various points from which distances for pedestrian walking distance have historically been computed.

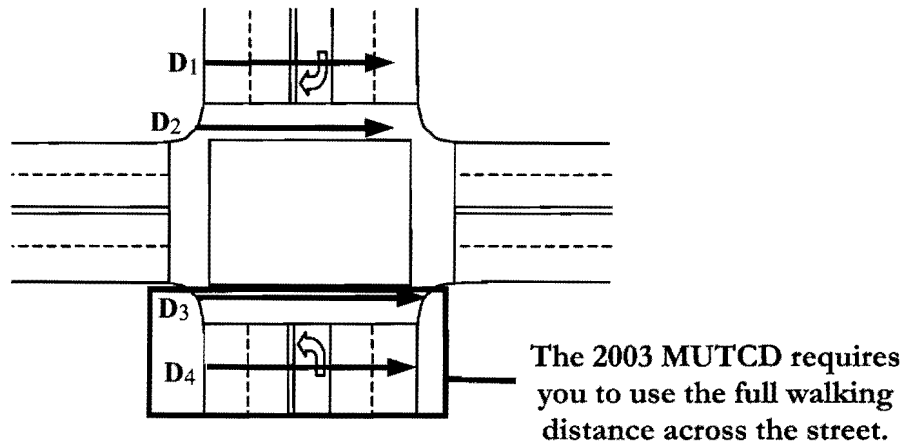

Once an appropriate distance is selected, Equation 5 is used to compute pedestrian time.

$$G_p = \text{Ped}_{\min} + \frac{\text{Distance}}{W} \quad 5)$$

- where:  $G_p$  = pedestrian time  
 $\text{Ped}_{\min}$  = minimum pedestrian “WALK” display, varies by agency  
 $\text{Distance}$  = distance measured in feet, using appropriate distance ( $D_3$ ,  $D_4$ ) from above figure, with  $D_4$  being the minimum  
 $W$  = walking speed in feet/second; 3.5 and 4.0 are commonly used; when pedestrian speeds are lower (school age, elderly or handicapped pedestrians), speeds should be reduced

The next figure relates how the pedestrian time minimums may influence signal timing where the minimum time required for vehicles is shorter than the minimum time required for pedestrians.

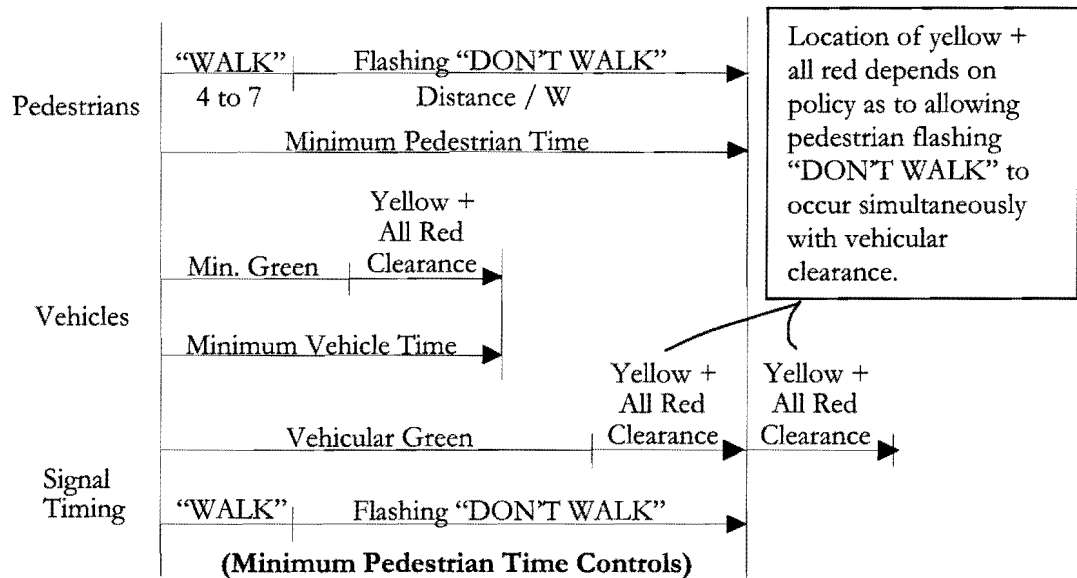

It is important to consider that if pedestrian push buttons are not present and pedestrian activity is probable, the minimum green + yellow + all red displayed for the through phase must be at least as long as the minimum pedestrian time,  $G_p$ , of the parallel pedestrian movement. When push buttons are present, the pedestrian “WALK” and flashing “DON’T WALK” times entered into the controller are subject to the same minimum requirements presented and calculated in this section. If computed pedestrian minimums are longer than vehicular minimums, the longer of the two minimums will control and should be entered. Some jurisdictions allow timing the pedestrian flashing “DON’T WALK” interval to time concurrently with vehicular clearance times; others do not.

**Key Point:** If pedestrian push buttons are not present and pedestrian activity is probable, the minimum green + yellow + all red displayed for the through phase must be at least as long as the minimum pedestrian green time,  $G_p$ , of the parallel pedestrian movement. When push buttons are present, the pedestrian “WALK” and “DON’T WALK” times entered into the controller are subject to the same minimum requirements presented and calculated in this section of the training guide. If computed pedestrian minimums are longer than vehicular minimums, the longer of the two minimums will control and should be entered.

## **Traffic Detection**

In either semi-actuated or actuated modes of operation, signal controllers require information about traffic approaching the intersection or interchange. Devices, known as detectors, provide this input to the signal controller. A variety of detectors are applicable, but the most common is the inductive loop detector, or simply “loop.” The loop itself is two or three turns (depending on loop length and environment) of wire placed in a sawcut in the pavement along the approach to the intersection/interchange. Wire leaders connect the loop to an amplifier, which is then connected to the controller. Loops and/or loop systems can be designed to cover multiple approach lanes.

Depending on approach speed, single or multiple loops may be used within a lane. Detectors can be operated in either presence or pulse mode. In presence mode, the amplifier sends the controller a “call” at all times when a vehicle is detected over the loop. In pulse mode, a short detection is sent to the controller following a vehicle arrival at the loop. At virtually all signalized intersections, detectors are operated in presence mode.

Another feature of detector operation is that detection can be set in locking and non-locking memory modes. Under locking memory, a detection call is “remembered” by the controller until the phase called by that detection is serviced. Under non-locking memory, the controller only registers a call when a vehicle is over the sensor. An example of the usefulness of this mode is right turn on red (RTOR) situations, where the vehicle is effectively “forgotten” if it is able to make a safe RTOR maneuver.

Detector layout for common signalized intersections is covered in the *Traffic Control Systems Handbook* [10] and the *Traffic Detector Handbook* [11]. However, there are few existing references to detector layout for signalized diamond interchanges. Thus, the system employed by TxDOT is presented here for common detector placements for the three- and four-phase control patterns.

### **Three-Phase Control**

The operational practices for use with three-phase control are presented below. A long (i.e., 6 ft × 40 ft) rectangular shaped inductive loop detector is used in the interior of the interchange for left turns. The through lanes are equipped with 6 ft × 6 ft loop detectors spaced 200 ft in advance of the stop bar. The placement of the detectors along the arterial and frontage road/ramp approaches is dependent on speed. Stop bar detection is made possible by a 6 ft × 40 ft loop in each lane. Stop bar detection is augmented by advance detectors (usually measuring 6 ft × 6 ft) placed in each lane. The advance detection placement is dictated by the speed of approaching traffic. The table below shows setback distances that have been computed for use with 6 ft × 40 ft stop bar loops under a three-phase control strategy. The figure below the table illustrates the resulting detector layout for a diamond interchange under three-phase control.



Speed (mph)	First Setback Loop Distance, S1 (ft)	Second Setback Loop Distance, S2 (ft)	Third Setback Loop Distance, S3 (ft)	Passage Time (sec)
30	100	n/a	n/a	2 to 3
35	135	n/a	n/a	2 to 3
40	170	n/a	n/a	2 to 3
45	210	330	n/a	2.0
50	220	350	n/a	2.0
55	225	320	415	1.2

Note: All setbacks in this table are for use with 6 ft × 40 ft stop bar loop.

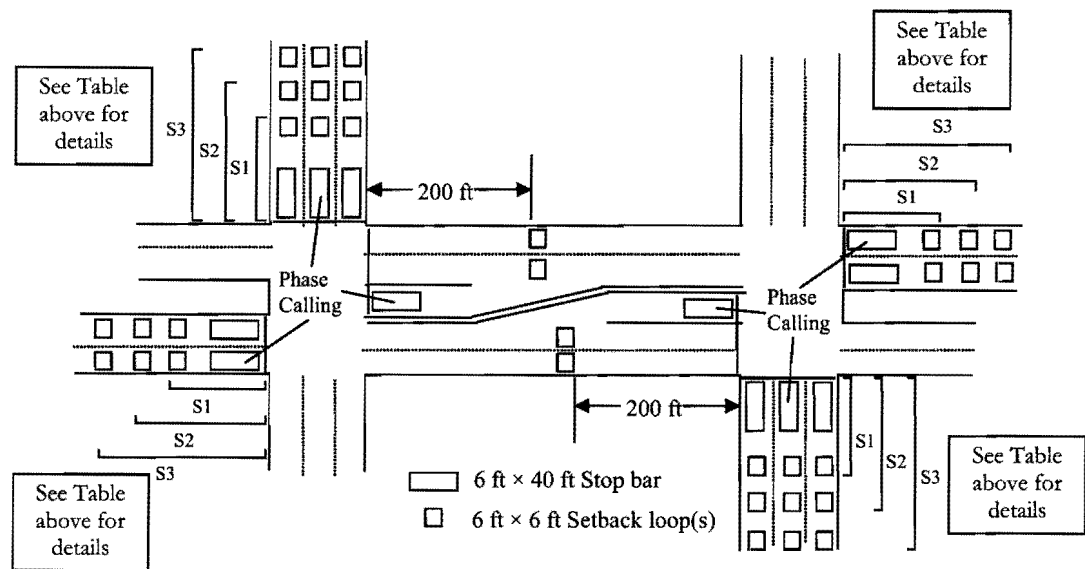

#### **Four-Phase Control**

The detector placement is slightly different for diamond interchanges under four-phase control. Arterial detector placement is based on the same logic used above, advance detectors supplemented with stop bar detection to ensure phase calls for stopped vehicles. Frontage road/ramp detector placement is dependent on clearance times and travel times within the interchange. The following procedure (illustrated in the next figure) can be used to calculate the setback distances for frontage loops.

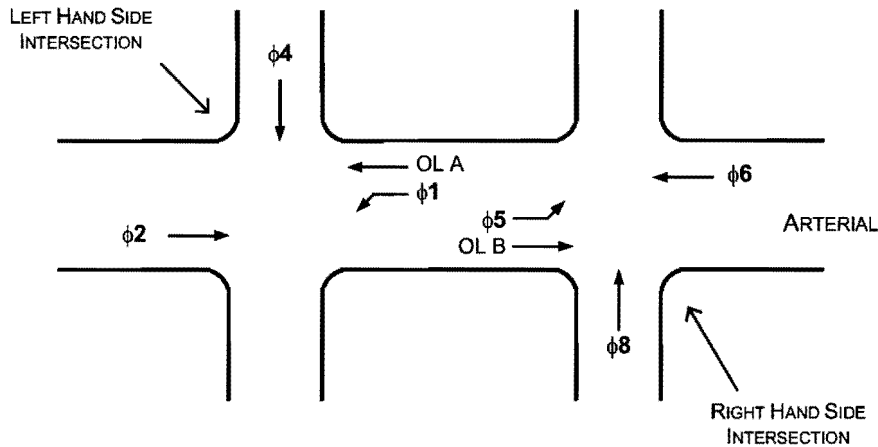

Time	Signal Change	Phase
(a)		Last vehicle hits detector on left frontage road, $\phi 4$
(b)	Gap Time	↓ $\phi 4$ gaps out; ↗ $\phi 5$ yellow begins
(c)	Yellow	↗ $\phi 5$ red clearance begins
(d)	Red Clear	↗ $\phi 5$ red clearance ends; ← $\phi 6$ begins
(e)	Start Up	↓ $\phi 4$ yellow begins
	Green Time	(vehicle from A reaches left intersection)
(f)	Yellow	↓ $\phi 4$ red clearance begins
(g)	Red Clear	↓ $\phi 4$ red clearance ends; ↙ $\phi 1$ begins
(h)	Buffer	Vehicle from D ( $\phi 6$ ) reaches left intersection

Measured travel time {

where (calculated in the given order):

- (a) = 0; For this example, consider (a) at time zero
- (b) = (a) + gap time for  $\phi 4$
- (c) = (b) +  $\phi 5$  yellow time
- (d) = (c) +  $\phi 5$  red clearance time
- (h) = (d) + measured travel time (from  $\phi 6$  (right) to next (left) intersection)
- (g) = (h) – buffer time (between frontage road phase & interior green, usu. 2 – 4 sec)
- (f) = (g) – red clearance for (left) frontage road
- (e) = (f) – yellow time for (left) frontage road

Following these calculations, the travel time from the setback detector to the ramp stop bar is calculated as (e) minus (a). The detector setback distance is computed as this travel time multiplied by the speed on the frontage road/ramp (in feet per second). If desired, 2 seconds can be added to the travel time (i.e., frontage road vehicle will be 2 seconds behind the stop bar at the onset of yellow) to improve operational efficiency and reduce cycle

length. The next figure shows a typical detector setup for a diamond interchange operating under four-phase control. If detector setback is compromised for practical considerations, it is important to have good gap settings and maximum times for efficiency.

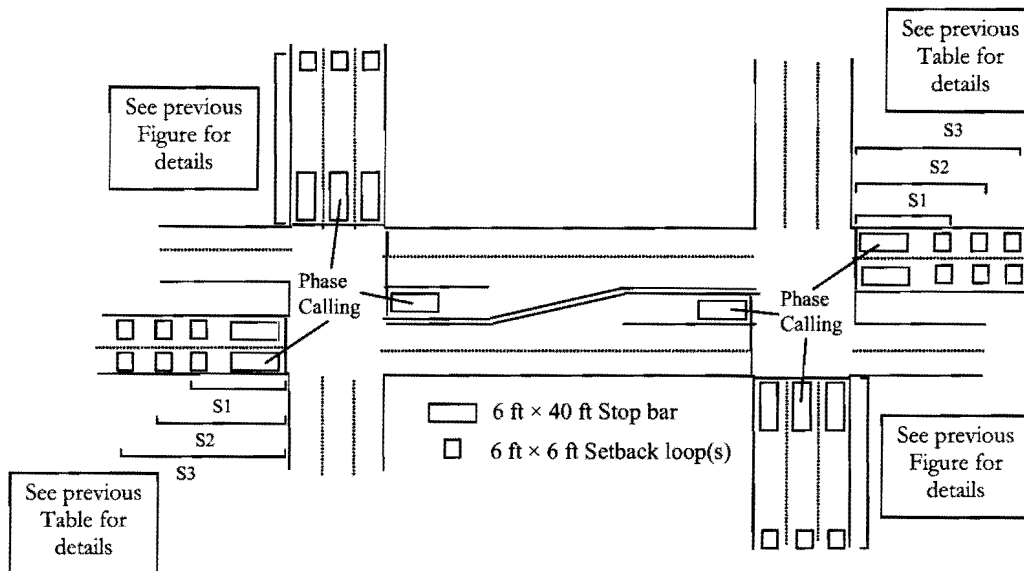

Both the three-phase and four-phase detector placement procedures must be calibrated based on site specific features. An additional feature of TxDOT's detector plans for interchanges is that the 6 ft x 40 ft stop bar loops may be "turned off" after: (1) the approach receives a green indication, (2) the detectors experience a gap of (usually) greater than 0.5 second, and (3) the other intersection's arterial phase has a detection. This procedure, known as detector switching, effectively uses the stop bar detectors to call the phase, and then turns them off so that the setback detectors can efficiently extend the phase. Without detector switching, the stop bar detectors unnecessarily extend the green beyond the time required to clear the platoon.

## Safety Considerations

### Yellow Trap

An important safety issue emerges for agencies considering using protected-permissive, also known as exclusive-permissive, phasing under phasing operations where left turns are in a lead-lag configuration (i.e., either NEMA phase 1 or 5 leads while the other lags). In a lead-lag situation with protected-permissive phasing, the normal sequence of indications for the primary arterial begins with the display of the leading left protected turn and its corresponding through+right "green ball" indication. The protected turn then terminates through the appropriate clearance indication and becomes a permissive left turn (where the leading left turners must now find gaps in the opposing through traffic stream, which has just received its "green ball" indication).

Note that using limited-visibility, or programmable, signal heads can also be used to alleviate the yellow trap situation. By not allowing left-turning vehicles to see the signal indications for their associated through movement, and vice-versa, potential driver error regarding the assumption that the opposing (through) phase is ending can be minimized. **Note that the 2003 MUTCD prohibits the display of signal indications that create the “yellow trap” situation.**

### ***Driver Expectancy at Diamond Interchanges***

When developing diamond interchange timing plans, it is essential to consider the environment in which the interchange is located. If you are developing a new timing plan for an interchange that is located along a freeway and all other interchanges along that freeway are operating using a TTI four-phase strategy, driver expectancy develops. Essentially, drivers will expect this interchange to operate similarly to the other interchanges along this freeway (and maybe even in this entire section of the city, if most interchanges operate in a TTI four-phase mode). In this instance, there is the expectation that vehicles departing the arterial approach to go through to the other side of the interchange will receive a green through and left-turn arrow when they reach the other intersection. Also, motorists turning left from the frontage road on green (with the exception of some U-turning vehicles) expect to be able to travel through the interchange without stopping again.

Where the controllers at two or more separate intersections are coordinated for traffic progression, coordination may get out of step, or fall out of synchronization, during cycle-by-cycle resynchronization, during a transition from one timing plan to another, during some pedestrian service calls, and during preemption. As the controllers attempt to regain coordination, shorter or longer phase times may be displayed for some phases, causing driver expectancy issues. This type of driver expectancy is mainly an issue for closely spaced intersections where signal heads may have visibility issues and drivers “expect” a certain operation/timing. This effect is intensified (and some additional controller limitations may impact operations) when the dual controllers managing the diamond are coordinated with other intersection and/or interchange controllers. All transition and coordination impacts must be thoroughly investigated by the traffic engineer developing the plan.

If the features of the timing plan that is to be implemented are significantly different than other interchanges in the area of the study interchange, serious thought should be given to all driver expectancy issues. It is significant to note that the closer the interchange spacing, the greater the driver expectation of green in the interchange interior. If driver expectation issues cannot be avoided, temporary signing should be displayed to indicate that signal operation at the interchange has been altered. As with all signal timing plan development issues, examination of driver expectation issues and (if necessary) countermeasures must be studied in depth, approved, and implemented by licensed civil (traffic) engineers and staff.

### ***Split Phasing***

A technique known as split phasing can be used where left-turn paths from opposing directions on a roadway (usually, on the cross street) overlap within the signalized intersection. Split phasing allows both movements from one cross street approach (say

phase 3 for the left turn and phase 8 for the through movement) to be fully serviced, and terminate together, before beginning the phases for the opposing cross street approach (say phases 4 and 7). In field implementation, this is most readily accomplished by wiring one cross street approach's left-turn and through signal heads to the phase 4 output and the other cross street approach's left and through signal heads to the phase 8 output. Then, the controller is programmed so that phase 4 and phase 8 are exclusive (i.e., cannot be timed together). Alternatively, one cross street approach's signal heads (left and through) can be driven by controller phase 3 and the opposing approach's signal heads (left and through) can be driven by phase 4. In this operation, the internal phase order within the controller will prevent phase 3 and phase 4 from timing simultaneously. In either case (i.e., using phases 3 and 8 or phases 3 and 4), the conflict monitor/malfunction management unit is programmed so that phases 3 and 8 (or phases 3 and 4) cannot be timed simultaneously.

### **Other Safety Issues**

A variety of other influences or specialized treatments may impact signalized operations. The prevalence of signal preemption devices or Intelligent Transportation System (ITS) technologies may require special consideration. Specialized traffic engineers, who understand the specific standards and guidelines required for installation, install many of these special configurations for dealing with these circumstances. These circumstances include railroad preemption if the intersection/interchange is adjacent to a railroad grade crossing, fire and/or emergency medical service (EMS) priority treatment, and bus transit and/or rail transit priority treatments. ITS technology (for instance, changeable lane assignment signs controlled by the traffic signal controller) is less prevalent and may also require special modifications to standard timing procedures developed within this guide.

## **Analysis Tools**

A number of computer programs are available to assist in the analysis and coordination of traffic signals on an arterial. All of these programs are based on the abstraction of reality and have their inherent weaknesses and strengths. In this section we provide a description of the most commonly used programs for analyzing and optimizing signal timings. We begin by describing key concepts needed to better understand these programs.

Traffic analysis software may contain one or both of the following modules:

- a traffic simulation model, also called a traffic model; and
- an optimization model.

These two types of models are described in the following subsections.

### **Traffic Signal Analysis Models**

A traffic model takes traffic volumes, geometric information for the facility, and a complete description of a traffic control plan as input. Then, it evaluates or simulates the described

scenario and outputs measures of effectiveness (MOEs). Typical MOEs include: average or total delay, number of stops, fuel consumption, bandwidth efficiency, average or maximum queues, etc. Most models provide an estimate of several, if not all, MOEs. One method of model classification is the primary MOE estimated by the model. The two main types of models are delay-based and bandwidth-based. Furthermore, the level of detail or abstraction used by a model is another classification method. There are three common types of traffic models based on the latter classification: microscopic, mesoscopic, and macroscopic.

### ***Microscopic Traffic Models***

Microscopic traffic models provide the most detailed analysis by simulating the behavior (acceleration, deceleration, car-following, lane changing, etc.) of individual vehicles in the traffic stream. In general, these models are also stochastic in nature and rely on a random number generator that uses a seed value to generate values of various parameters during simulation. To obtain another sample, the user must change the seed value and re-run the simulation. Running the simulation with different random number seeds is equivalent to collecting random samples of data, similar to collecting data for a peak period over several consecutive days. Due to the level of detail simulated, these models require the maximum amount of data and are the most computationally intense.

### ***Mesoscopic Traffic Models***

These models simulate traffic flow in specified time steps, and they are usually deterministic in nature. The time step can be 1 second, 2 seconds, or higher. For each time step, these models estimate the flow of traffic entering a link, traveling downstream, stopping due to a red light, and moving again when the light turns green. Some of these models also account for platoon dispersion as vehicles travel from one point to a downstream point in space. Mesoscopic models can be further classified as link-based or time-based. Link-based models simulate traffic flow one link at a time for all time steps in a signal cycle. These models treat a queue of vehicles at the signal approach as an upward stack. As a result, all vehicles arriving during red travel to the stop bar and join a vertical (upward stack) queue. Link-based models cannot account for queue spillback because they do not keep track of the back of the queue. In addition, they may allow more vehicles to stack in a queue than a link's storage capacity. Thus, these models are not suitable for congested conditions or for short links where sub-optimal timing may cause queues to block flow from the upstream signal. Step-based models, on the other hand, simulate traffic flow on all links at each time step. These models can accurately account for the behavior of queued traffic and traffic flow interactions between adjacent links, and they are better suited for all types of traffic conditions in signal systems. The down side is that they are also more intense from a computational point of view. Also, the accuracy of these models may depend on the number of cycles simulated.

### ***Macroscopic Traffic Models***

Models in this category simulate the cycle-by-cycle behavior of platoons of traffic at each link in the system and are deterministic in nature. These models may or may not account for platoon dispersion. Macroscopic models treat a queue of vehicles at an approach as an upward stack. Thus, they are accurate only for undersaturated flow conditions. Because of

their simplistic nature, macroscopic models are the most efficient from a computational point of view.

### **Optimization Models and Search Algorithms**

As mentioned earlier, traffic models simulate a given set of traffic and control conditions. In other words, they are able to tell only how good or bad a given scenario is. Optimization and search algorithms are techniques that systematically generate scenarios, compare their fitness or objective function value (i.e., delay, bandwidth efficiency, throughput, etc.) obtained by using a simulation or analytic model, and select the best scenario based on a predetermined criterion. For instance, if delay minimization is the desired objective, the primary fitness value will be the delay to motorists resulting from a specific scenario. Such an optimization model will evaluate the delay value for each alternative timing plan and select the timing plan that results in the least amount of delay. In other words, search algorithms are “wrappers” around traffic simulation or analytic models to provide the optimization function. Search algorithms can be simple or extremely sophisticated. Some of the common search algorithms are described below.

#### ***Exhaustive Search Algorithms***

As the name implies, these algorithms calculate and compare the selected fitness values for all possible signal timing scenarios. It should be noted that there can be millions of such combinations of signal timing parameters depending on the size of the facility and how many variables are to be optimized simultaneously. Thus, exhaustive search may require hours of computer time. Unless a model is designed for small facilities, the sheer number of possible scenarios usually requires the use of a divide-and-conquer strategy. For instance, computational time can be drastically reduced by stage-wise optimization of each variable instead of all variables simultaneously and/or by using a simple analytic or simulation model. Such strategies increase computational efficiency by sacrificing accuracy. The positive feature of exhaustive algorithms is that full information is available for each scenario analyzed. Most optimization algorithms use some level of exhaustive search combined with other search algorithms.

#### ***Hill-Climbing Algorithm***

A hill-climbing (or valley descent) algorithm starts with a base scenario specified by the user, selected by the program using a fixed criterion, or selected randomly. Then, it selects a variable to be optimized (i.e., offset, cycle length, etc.) and creates two additional scenarios for this variable, one by increasing the values of that variable and the other by decreasing the value. Initially, the value of the selected variable is increased or decreased by a specified amount called the step size. Following this, the algorithm uses a traffic simulator to calculate the fitness values for each of the two new scenarios and compares them with the base scenario. These evaluations identify the two best scenarios and, consequently, a direction of further search. For instance, if increasing the value of the selected variable resulted in a better fitness value, the search algorithm will mark this new scenario as the current best and continue searching in the direction of increasing values for the variable. In the next iteration, the search algorithm generates a new scenario by increasing or decreasing the value of the

selected variable in the selected search direction, calculating the new fitness value, and comparing it with the two current best values. The algorithm continues in this manner until the fitness value for the new scenario ceases to be better than the current best. Hill-climbing methods guarantee optimal solutions only when the function to be optimized is unimodal (has one peak or valley). For multi-modal functions, the hill-climbing method may terminate with a sub-optimal solution depending on how good the base scenario is. Most implementations of hill-climbing algorithms use sophisticated techniques, such as a variable step size, to speed up the search process.

### **Mathematical Programming Techniques**

Mathematical programming techniques, such as linear- and integer-programming, require a complete specification of the objective (fitness) function along with all the applicable constraints of the traffic model in mathematical form (equations and/or inequalities). These techniques are based on systematic procedures (programs) that are designed to search a small subset of all possible scenarios in an intelligent manner. Mathematical programming techniques are applicable only when a closed-form mathematical model exists. When applicable, these techniques also guarantee the best solution. Further discussion of these techniques is beyond the scope of this report.

### **Genetic Algorithms**

Genetic algorithms (GAs) belong to a class of algorithms known as evolutionary algorithms which have been developed fairly recently. A GA starts with a subset of scenarios (some members of a population) and applies principles of natural selection (mating, gene mutation, etc.) to generate a new or revised set of scenarios (called the next generation). A GA-based optimization model uses a specified traffic simulation model to evaluate the fitness of each member (i.e., a signal timing scenario) in the current population. Then, it generates a new population by combining the characteristics of (that is, by mating) selected pairs of scenarios (members). The principles of natural selection ensure that the characteristics of the fittest members (i.e., those with higher bandwidths or lowest delays, depending on the objective of optimization) have a high probability of transmission to the next generation. A GA terminates when either no more improvements occur, or a certain number of user-specified generations are complete, whichever occurs first. GAs are different from all previously described search algorithms in that they utilize codings of variables rather than the values of variables. Given a large enough population and sufficient number of generations, a GA can provide the global optimum. This is because GAs perform simultaneous optimization of all selected variables. Furthermore, GAs can be applied to all types of optimization problems, even those that cannot be described in closed forms. Their effectiveness depends on the scheme used for coding the variables and the details of the natural selection process used. Conceptually, an exhaustive optimization algorithm is a GA that uses all members of a population, and it applies only the initial generation of the optimization algorithm.



## **Popular Signal Timing Analysis and Optimization Programs**

### ***TSISICORSIM***

CORSIM [13] is a microscopic-stochastic simulation program. It has two modules: FRESIM for evaluating freeway traffic conditions and NETSIM for evaluating the quality of a selected signal timing plan. TRAFVU is an accompanying graphic animation program. NETSIM can be used to analyze the operation of pretimed and actuated signals. For a given scenario, CORSIM randomly generates traffic, keeps track of individual vehicles as long as they are in the system, and computes various measures of effectiveness (delay, stops, travel times, fuel consumption, etc.). Making a simulation run using CORSIM is similar to one-time data collection in the field, for instance the duration of the AM-peak period on Monday. Thus, it is necessary to make several runs using different random number seeds and averaging the results from those runs before drawing any conclusions. CORSIM was developed using Federal Highway Administration (FHWA) support over a period of several decades and is accepted by transportation professionals as a valid analysis tool. CORSIM does not provide an optimization routine. Therefore, it is difficult, if not impossible, to use CORSIM for developing optimal signal timing plans.

### ***TRANSYT 7F***

TRANSYT 7F [14] is a mesoscopic-deterministic model for analyzing and optimizing signal timings on arterials and networks. Like CORSIM, TRANSYT 7F has been developed and tested over a period of several decades and has gained acceptance from the user community as a sound model. TRANSYT 7F uses a combination of exhaustive, hill-climbing, and GA-based optimization methods. TRANSYT 7F uses a delay-based traffic model. In other words, it is primarily designed to select signal timings that produce minimum system delay and stops. In addition, it provides a capability to select several secondary objectives, including minimization of stops and maximization of progression opportunities. During its optimization process, TRANSYT 7F generates second-by-second flow profiles of vehicles on all links in the network. Then, it analyzes these profiles to determine MOEs. TRANSYT 7F has two delay-based traffic models. The first model (original model) performs the optimization in a link-wise fashion by optimizing timings for one link at a time. This model does not accurately account for queue buildup because it treats a queue of vehicles as an upward stack at the stop bar. However, it works well for undersaturated traffic conditions. Users all over the world have extensively validated this model. The second model was recently added to remove the limitations of the first model. This model takes into consideration the formation and dissipation of queues in space. In addition, it accounts for flow interactions on adjacent links through a step-by-step analysis of all links in the system. Conceptually, this model is better suited for the analysis and optimization of congested (oversaturated) facilities. Consequently, it also requires more computation time. Until recently, the main deficiency of TRANSYT 7F has been its inability to optimize signal phase sequences. In the latest version of TRANSYT 7F (version 9) released earlier this year, this deficiency was removed through the addition of a GA-based optimization algorithm. TRANSYT 7F models actuated signals as equivalent pretimed signals, and it has the ability to half/double cycle traffic signals.

TRANSYT 7F performs exhaustive searches for cycle length. For each cycle, it starts by calculating equal saturation splits and applies a hill-climbing method to optimize signal offsets and splits. For this reason, its final results depend on the base timing plan supplied by the user. Although it contains a good delay-based traffic model, TRANSYT 7F's bandwidth analysis model is not very good. Last, but not least, learning to use TRANSYT 7F requires considerable effort.

### **Synchro**

Synchro [15] is a delay-based program for analyzing and optimizing timing plans for arterials and networks. Its objective function also minimizes stops and queue size by applying penalties for these measures. Synchro's traffic model is similar to the link-based model in TRANSYT 7F. Synchro uses an exhaustive search technique to optimize signal timings. To reduce the number of scenarios analyzed for a coordinated system, it relies on the divide-and-conquer principle. To optimize timings for an arterial, the program requires the user to apply several manual steps (cycle length optimization followed by offset and phase sequence optimization) in a specific order. It optimizes cycle length by analyzing all cycles in the defined range. Synchro optimizes offsets using a multi-stage process. At each stage, it uses a different step-size depending on the optimization level selected by the user. For instance, if the user requests extensive offset optimization, Synchro first simulates all offsets in 4-second increments, followed by a search using 2-second increments. Finally, it performs another search using 1-second increments in the vicinity of the best offset from the second stage. Unlike TRANSYT 7F, Synchro's traffic model does not consider platoon dispersion. As an alternate, it recommends when to coordinate two adjacent signals by calculating a *coordinatability factor* using link distance, travel time, and traffic volumes as input. Also, unlike other programs, Synchro generates optimal signal timings for each signal by averaging the analysis results of five volume scenarios for that signal. For this purpose, it assumes that a volume entered by the user is the mean and variance of the real traffic volume (Poisson distribution). Then, it applies factors from a Normal distribution to generate four additional volume scenarios representing minus-2 (10<sup>th</sup> percentile), minus-1 (30<sup>th</sup> percentile), 1 (70<sup>th</sup> percentile), and 2 (90<sup>th</sup> percentile) standard deviations from the mean. In this scheme, user-supplied volumes are treated as 50<sup>th</sup> percentile volumes. In Synchro terminology, delay calculation based on this averaging method is referred to as the percentile delay method. Using this method, Synchro incorporates a method to model phase gapping and skipping behavior for actuated and actuated-coordinated signals. Synchro has, by far, the best user interface of all signal-timing tools currently available to traffic engineering professionals. It provides features to easily fine-tune a timing plan. Furthermore, it provides for data conversion to other popular software.

### **PASSER II**

PASSER II [16] is a bandwidth-based program for optimizing signal timings for signalized arterials. Originally developed for TxDOT about 30 years ago, it has been one of the most popular programs in its class. The heuristic signal timing optimization model of PASSER II is based on a graphical technique, and is simple, efficient, and powerful [17]. PASSER II has passed the test of time and is known to produce good signal timing plans. PASSER II can determine all four signal-timing variables described earlier. It selects the plan that maximizes

progression efficiency, a unitless quantity obtained by dividing the progression band by the cycle length. Because of its simplicity, it is also the most computationally efficient program in its class. PASSER II performs exhaustive searches over the range of cycle length provided by the user. It starts by calculating splits using Webster's method. Then, it applies a hill-climbing approach and adjusts splits to minimize delay. Finally, it applies its bandwidth optimization algorithm using the pre-calculated splits as input to that model. At the optimization stage, it can find the cycle length, offsets, and phase sequences that produce maximum two-way progression.

### **PASSER III**

PASSER III [18] is a delay-based program for optimizing timings at diamond interchanges, especially those using a single controller. It can also coordinate a series of diamond interchanges along one-way frontage roads. For a single interchange, PASSER III uses an exhaustive optimization method. It evaluates each timing plan (cycle, split, and phasing) using delay-difference-of-offset method [19], and selects the plan that produces the least interior delay. For a series of interchanges, PASSER III saves four least-delay timing plans for each interchange. Then, it applies PASSER II's interference minimization algorithm and selects plans for interchanges that result in maximum progression along the two frontage roads. PASSER III produces accurate results for undersaturated traffic conditions and can be applied to diamonds with or without U-turn lanes using three- or four-phase signal operations.

### **PASSER IV**

PASSER IV [20] is a program for maximizing arterial progression in arterial and multi-arterial signal networks. This program uses a mathematical programming technique for optimizing signal timings. It uses the same macroscopic delay model as PASSER II.

## **PASSER V**

PASSER V-03 is the latest in the PASSER series of programs developed by TTI [21] for timing arterials and signalized diamond interchanges. It has a graphic user interface that is integrated with the best optimization technologies currently available. Although the program focuses on the coordination of two or more signals on a linear arterial, it also provides basic features to analyze and time isolated signals. PASSER V can develop signal timings to maximize progression or minimize systemwide delay. Its traffic simulation can analyze undersaturated and oversaturated traffic conditions along signalized arterials. This section describes models used by PASSER V, descriptions of tools available in the program, and its limitations.

### **Optimization Algorithms in PASSER V**

PASSER V uses several optimization algorithms. These algorithms include exhaustive search, interference minimization, and genetic algorithms. This section describes these algorithms.

### **Interference Minimization Algorithm**

This algorithm is a revised version of the optimization algorithm used by PASSER II. Here, we first describe the PASSER II implementation of the interference minimization algorithm and then describe modifications for implementation in PASSER V.

Like most programs, PASSER II calculates preliminary splits for each signal based on Webster's method. Then, PASSER II applies an optimization method to adjust these splits to minimize intersection delay. These pre-calculated splits are then input to the bandwidth optimization algorithm. For bandwidth optimization, PASSER II starts by selecting a cycle and calculating perfect one-way progression in the A (arbitrarily selected) direction. Then, it minimizes band interference in the B (opposite) direction by adjusting phasing sequences and offsets. The maximum total band calculated by the program is as follows:

$$\text{Total Band} = G_A + G_B - I$$

where:

$$\begin{aligned} G_A &= \text{least green in A-direction} \\ G_B &= \text{least green in B-direction} \\ I &= \text{minimum possible band interference} \end{aligned}$$

After achieving the best band (minimum interference) in the B direction, the program adjusts the two bands according to user-desired options for directional priority. The reader should note here that the interference minimization algorithm intelligently searches a very small subset of all possible combinations of signal timings. Finally, the program calculates delays, bandwidth efficiency, and attainability. Delay calculation for each interior through movement is based on a macroscopic traffic model, whereas delay for all other movements is calculated using the HCM delay formula. Efficiency and attainability measure how good a bandwidth solution is. Efficiency for a direction is the percent of cycle used for progression. Attainability is the percent of bandwidth in a direction in relation to the minimum green split in that direction. Theoretically, the maximum bandwidth in a direction can be no more than the smallest through green split in that direction. The following formulas are used to calculate combined efficiency and attainability for the two arterial directions:

$$\text{Progression Efficiency (\%)} = \frac{(\text{Arterial Band}_A + \text{Arterial Band}_B)}{2 \times \text{Cycle Length}} \times 100$$

$$\text{Progression Attainability (\%)} = \frac{(\text{Arterial Band}_A + \text{Arterial Band}_B)}{(\text{Min. Green}_A + \text{Min. Green}_B)} \times 100$$

The reader should note that while bandwidth generally increases with an increase in cycle length, efficiency may increase, decrease, or remain constant. Thus, it is desirable to select a solution that provides the best efficiency and an attainability of 100 percent. In addition, the

timing plan should not use cycle lengths larger than that necessary to move traffic through all approaches on the arterial.

It is a well-known fact that PASSER II-90 has a tendency to select larger optimal cycle lengths. Recently, TTI researchers found that this tendency is because of the split optimization feature implemented in PASSER II. What happens in PASSER II is that the split optimization gives more and more green time to the through traffic as cycle lengths increase. Since PASSER II optimizes bandwidth, it tends to select larger cycle lengths because of larger bands and efficiencies. TTI researchers decided to not use the split optimization feature in the PASSER V implementation of the algorithm. Thus, the splits calculated in PASSER V are slightly different from those in PASSER II. In addition, researchers found that in some cases, the interference minimization algorithm of PASSER II ends before finding the best solution. This is because of the heuristic nature of the algorithm and the fact that the algorithm only considers a subset of all possible solutions. This discrepancy was resolved in the PASSER V implementation of the algorithm by applying the algorithm for both directions, thereby increasing the ability of the algorithm to find better solutions.

#### ***Exhaustive Search Method***

PASSER V uses this search method for cycle length versus delay analysis of isolated signals, for cycle length optimization in conjunction with the interference minimization algorithm, and for the optimization of isolated diamond interchanges.

#### ***Genetic Algorithm***

PASSER V uses a genetic algorithm to provide new features to develop signal timings for minimizing delay or for maximizing arterial progression. Because this technology is fairly new, we provide a more detailed description of genetic algorithms. GAs are optimization techniques based on the concepts of natural selection and genetics. Genetic algorithms differ from traditional algorithms in that they work with a coding of the parameter set, not the parameters themselves; search from a population of points, not a single point; and use probabilistic rules, not deterministic rules. In the genetic algorithm approach, the variables are represented as genes of a chromosome. The standard genetic algorithm proceeds as follows [22]:

1. It randomly or heuristically generates an initial population (generation 0) of candidate solutions for a given problem.
2. For every evolutionary step known as a generation, it evaluates the fitness (bandwidth, delay, etc.) of each solution.
3. It forms a new population (the next generation) by selecting the individuals with best fitness and applying natural selection schemes (genetic operation, mutation, and recombination) to pairs of individuals.
4. It removes unwanted members of the population to make room for new members.
5. It evaluates new individuals and inserts them into the population pool.
6. If termination criterion is met, it stops, otherwise it goes back to step 3.

A single iteration of this loop is referred to as a generation. Natural selection guarantees that individuals with the best fitness will propagate into future populations. Using the recombination operator, the GA combines genes from two parents to form two new offspring that have a high probability of having better fitness than their parents. Mutation allows infusion of features not present in parents. Over several generations, the best individuals survive and the worst are eradicated. The reader should note that the pre-selected population size remains unchanged from one generation to the next. The following figure shows a flowchart of this methodology.

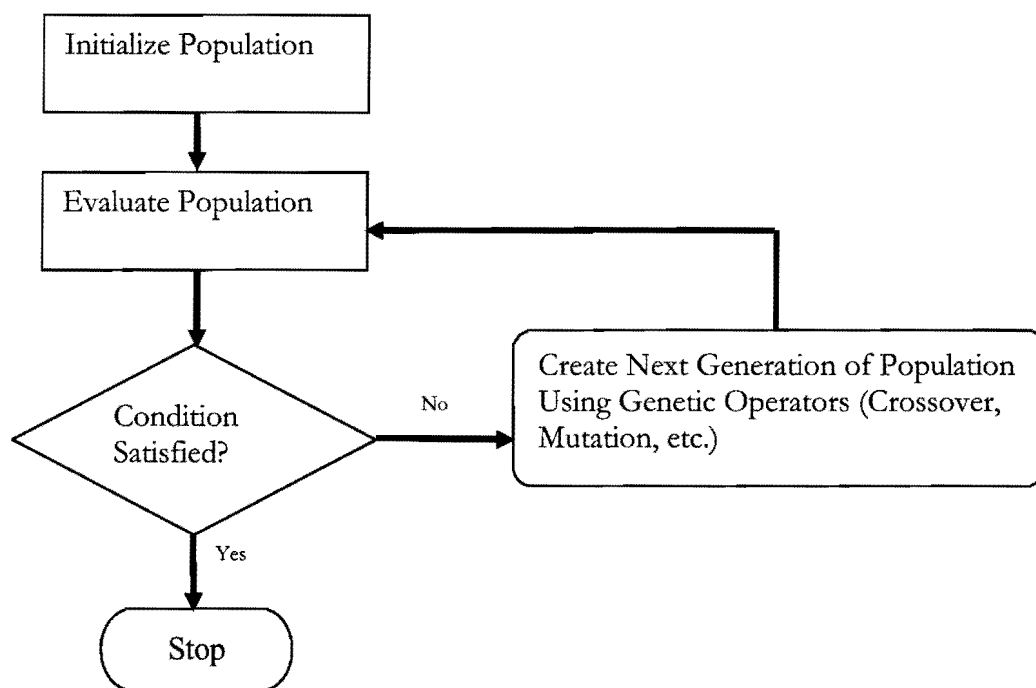

Genetic algorithms provide the capability of optimizing all the signal-timing parameters in parallel, unlike the hill-climbing method, which optimizes one timing parameter at a time. Consequently, GAs may also require more time. Many studies conducted to date have shown that GA-based optimization performs better than the hill-climbing method.

A GA software, or driver, must be employed for applying this optimization technique. PASSER V uses the GA library (GAlib) developed by Matthew Wall [23] because of its flexibility and availability without cost and copyright regulations. Understanding the following terminology will be beneficial to the users of PASSER V.

### ***Types of Genetic Algorithms***

There are several types of GAs. The most common types are:

1. simple genetic algorithm, and
2. steady-state genetic algorithm.

A simple genetic algorithm creates an initial population by cloning the individual or population passed when it is created. For each generation, the algorithm creates an entirely new population of individuals by selecting pairs of individuals from the previous population and mating them to produce two new offspring for the new population. This process continues until the stopping criteria are met (determined by the terminator).

A steady-state genetic algorithm applies overlapping populations with a user-specifiable amount of overlap. The algorithm creates a population of individuals by cloning the chromosomes of the previous population. For each generation, the algorithm creates a temporary population of individuals, adds these to the previous population, and then removes the worst individuals in order to return the population to its original size. The amount of overlap between generations is selected by specifying the *Replacement* parameter. This is the percentage of the population that should be replaced each generation. Newly generated offspring are added to the population, and then the worst individuals are destroyed (so the new offspring may or may not make it into the population, depending on whether they are better than the worst in the current population).

### **Elitism**

Elitism applies only to a simple GA. Elitism means that the best individual from each generation is always carried over to the next generation.

### **Selection Scheme**

The selection method determines how individuals are chosen for mating. If one uses a selection method that picks only the best individual, then the population will quickly converge to that individual. So the method should be biased toward better individuals; but it should also pick some offspring that are not quite as good overall but may have good characteristics. Some of the more common selection methods include: roulette wheel selection (the likelihood of picking an individual is proportional to the individual's fitness such as bandwidth or delay), tournament selection (a number of individuals are picked using roulette wheel selection, then the best of these are chosen for mating), and rank selection (pick the best individual every time).

### **Population Size**

The size of the population in each generation quite often affects the solution. A population size of five to a population size of tens of thousands is used, depending on the evolutionary strategy and the nature of the problem that one is trying to solve. In a solution space of  $N$  possible solutions, a population of  $N$  individuals can solve the problem in 1 generation; however,  $N$  is often far too big (or unknown) to do that. Solution space affects the population size; hence multiple runs need to be conducted for each kind of problem to select the optimal population size.

### **Termination Criteria**

GAs are terminated using two criteria: (1) convergence, and (2) number of generations. In PASSER V, convergence is defined as the ratio of the average score of  $N$  previous best

generations to the score of the current best-of-generation. One can also define the maximum number of generations after which the GA evolution should stop.

### **Crossover Probability**

Crossover probability is the probability that two parents mate. An appropriate probability will allow parents to mate and thus make possible search of new solution spaces. In effect, evolutionary techniques are most useful for problems where the variables have complex, interacting dependencies, and a direct optimization algorithm is unknown. Selection and mutation alone cannot solve such problems when the solution space is large. Crossover is the real power behind evolutionary algorithms, and it improves performance by many orders of magnitude in most problems.

### **Mutation Probability**

Mutation probability is the probability with which a given chromosome changes its state between generations. A high mutation probability will essentially lead to a random search of the solution space.

### **Replacement Probability**

Replacement probability specifies the amount of overlap between generations. It only applies to steady-state GAs.

## **Analytical and Simulation Models**

Several simulation or evaluation models have been included in PASSER V. These models are used by optimization algorithms and by other analysis tools. In this section, we describe these models. A significant portion of this section is devoted to the new traffic model included in the program.

### **Analytical Models for Basic Calculations**

PASSER V uses HCM and Webster's methods for calculating saturation flow rates and green splits, respectively [6, 24]. The saturation flow rates for movements sharing a lane are calculated using an iterative procedure that prorates saturation flow rate of the shared lane using volumes of movements served by the shared lane. Furthermore, PASSER V uses the first two terms of the HCM model for calculating delay for isolated signal approaches. Since Webster's formula for calculating minimum delay cycle length fails for signals near, at, and over capacity, PASSER V calculates splits and delay for each cycle length in the desired range to determine and recommend the minimum delay cycle length for a signal. In addition, PASSER V uses Akcelik's models for calculating stops per vehicle, average queue, and maximum queue [25]. Finally, the program uses the PASSER II program's model for calculating fuel consumption. These models are presented in the following subsections.

### **Saturation Flow Calculations**

For calculating saturation flow rates for each movement, PASSER V defines each lane as a separate group and begins by assigning ideal saturation flow rate to each movement. Then, it applies adjustment factors for lane width, grade, parking, stopping buses, and area type. The program also applies adjustment factors to volumes. These include: appropriate left- and/or



right-turn adjustment factors, peak-hour factor, growth factor, and factor for truck percentage. Finally, it performs iterative calculations to prorate saturation flow rate for movements serviced by shared lanes. This procedure assumes that the number of vehicles in each lane remains balanced. In the calculation process, the procedure also identifies any shared lane that is a de facto left- or right-turn lane. The example given below describes this procedure. For this example, we assume values of 1.0 for most adjustment factors. In addition, we assume that all left-turn phases are protected only.

Step 1: Create a matrix containing rows and columns identifying types of movements and number of lanes for the current approach. Enter ideal saturation flow rate (1900 vphgpl) and user supplied volumes (150, 500, and 600 for left-turn, through, and right-turn movements) in appropriate fields. Enter a 1 under each lane to identify the movements permitted from that lane. Our example has one exclusive left-turn lane, one shared left-through lane, one exclusive through lane, and one shared through-right lane.

Movement Type	Lanes				Movement Volume
	Left Lane	2 <sup>nd</sup> Lane	3 <sup>rd</sup> Lane	4 <sup>th</sup> Lane	
Left	1	1			150
Through		1	1	1	500
Right				1	60
Saturation	1900	1900	1900	1900	

Step 2: Apply adjustment factors for turns (that is divide volume by 0.95 for left turn, and by 0.85 for right turn), and adjustment factors for heavy vehicles (1 in this example) to each movement volume.

Movement Type	Lanes				Movement Volume
	Left Lane	2 <sup>nd</sup> Lane	3 <sup>rd</sup> Lane	4 <sup>th</sup> Lane	
Left	1	1			157.89
Through		1	1	1	500
Right				1	70.59
Saturation	1900	1900	1900	1900	

Step 3: Allocate saturation flow rate in each column equally to each movement allowed for that lane (Column Operation).

Movement Type	Lanes				Movement Volume
	Left Lane	2 <sup>nd</sup> Lane	3 <sup>rd</sup> Lane	4 <sup>th</sup> Lane	
Left	1900	950			157.89
Through		950	1900	950	500
Right				950	70.59
Saturation	1900	1900	1900	1900	

Step 4: Allocate movement volume to each lane providing for that movement in proportion to the non-zero values. For instance the calculation for left-turn volume in the left lane will be:

$$157.89 \times \frac{1900}{1900 + 950} = 105.26$$

Movement Type	Lanes				Movement Volume
	Left Lane	2 <sup>nd</sup> Lane	3 <sup>rd</sup> Lane	4 <sup>th</sup> Lane	
Left	105.26	52.63			157.89
Through		125	250	125	500
Right				70.59	70.59
Saturation	1900	1900	1900	1900	

Step 5: Allocate saturation flow for each column proportional to the values for each movement volume in that lane. For instance the calculation for left-turn volume in lane 2 will be:

$$1900 \times \frac{52.63}{52.63 + 125} = 562.95$$

Movement Type	Lanes				Movement Volume
	Left Lane	2 <sup>nd</sup> Lane	3 <sup>rd</sup> Lane	4 <sup>th</sup> Lane	
Left	1900	562.95			157.89
Through		1337.05	1900	1214.27	500
Right				685.73	70.59
Saturation	1900	1900	1900	1900	

Step 6 through N: Repeat Steps 4 and 5 until saturation flow rates converge (that is, stop changing). At this point add the saturation flow rates for each row to calculate the final adjusted saturation flow rate for each movement. Then apply adjustment factors for turns, and adjustment factors for heavy vehicles to the adjusted saturation flow rate to obtain the final saturation flow rate for each movement. The reader can verify that the final matrix is as follows:

Movement Type	Lanes				Movement Volume
	Left Lane	2 <sup>nd</sup> Lane	3 <sup>rd</sup> Lane	4 <sup>th</sup> Lane	
Left	1900	0			157.89
Through		1900	1900	1194.85	500
Right				705.15	70.59
Saturation	1900	1900	1900	1900	

The final saturation flow rates for left-turn, through, and right-turn movements are 1805 (1900×0.95), 4995, and 599 (705.15×0.85), respectively.

For permitted left-turn phases, the program applies additional adjustments based on whether the permitted movement is from a shared or exclusive lane. These adjustments are described below.

#### Exclusive Lane Case

$$s_{permitted} = \frac{v_{opp} \times e^{-4.5v_{opp}/3600}}{1 - e^{-2.5v_{opp}/3600}} \times f_w \times f_g \times f_p \times f_b \times f_a$$

where:  $v_{opp}$  = opposite volume

$f_w$  = factor for lane-width

$f_g$  = factor for approach-grade

$f_p$  = factor for parking

$f_b$  = factor for bus-stops

$f_a$  = factor for area-type

#### Shared Lane Case

1. Use the iterative procedure described above to calculate saturation flow rate for each shared lane ( $s_{Total}$ ) as well as the saturation flow rates for each shared movement (for instance the saturation flow rate for left-turn movement,  $s_L$ ) in that lane.
2. Calculate saturation flow rate for each permitted-left-turn movement ( $s_{permitted}$ ) as if the movement was served by an exclusive lane.
3. Calculate the adjusted saturation flow rate for the shared lane as follows:

$$s_{adjusted} = s_{permitted} \times \frac{s_L}{s_{Total}} + (s_{Total} - s_L)$$

4. Allocate  $s_{adjusted}$  using the original movement-saturation-flow to  $s_{Total}$  ratios. For instance, the calculation for left-turn movement is  $s_{adjusted} \times (s_L / s_{Total})$ .
5. Apply the left- and right-turn factors when appropriate.

#### **Split Calculations**

Once the saturation flow rates have been obtained, PASSER V calculates equal saturation splits for the given cycle length as follows:

1. Calculates effective cycle length by subtracting the total lost time from the cycle length.
2. Calculates volume to saturation flow ratios for each movement and determines the critical movements in each barrier.
3. Allocates the effective cycle length to each critical movement using the flow ratio for the subject movement and the sum of flow ratios for all critical movement.
4. Adds lost time back to each movement.
5. Calculates splits for non-critical phases.

### **Estimation of Delay**

The program uses the following equation for estimating control delay for all approaches where random arrivals are assumed.

$$\text{Control Delay} = d = d_1 + d_2$$

$$d_1 = \frac{0.5 \times C \times \left(1 - \frac{g}{C}\right)^2}{1 - \left[\min\left(1, \frac{v}{c}\right) \times \frac{g}{C}\right]}$$

$$d_2 = 900 \times 0.25 \times \left[ \left(\frac{v}{c} - 1\right) + \sqrt{\left(\frac{v}{c} - 1\right)^2 + \frac{4 \times (v/c)}{0.25 \times c}} \right]$$

where:  $d_1$  = uniform delay  
 $d_2$  = incremental delay  
 $g$  = effective green  
 $C$  = cycle length  
 $c$  = capacity  
 $v$  = volume

### **Estimation of Queues and Stops**

Queues and stops are estimated by the program using the following models:

$$\text{Average Stops per Vehicle} = h = 0.9 \left( \frac{1-u}{1-y} + \frac{N_0}{qC} \right)$$

where:  $u$  = green split ratio ( $g/C$ )  
 $y$  = flow ratio ( $q/s$ )

- $q$  = flow in vehicles per second  
 $C$  = cycle length  
 $N_0$  = average overflow queue in vehicles

$$\text{Average Overflow Queue} = N_0 = \frac{QT_f}{4} \left( (x-1) + \sqrt{(x-1)^2 + \frac{12(x-x_0)}{QT_f}} \right)$$

- where:  $Q$  = capacity in vehicles per hour  
 $T_f$  = flow period in hours (assumed 0.25)  
 $x$  = degree of saturation ( $q/Q$ )  
 $x_0$  =  $(0.67 + sg/600)$ , where  $s$  and  $g$  are saturation flow rate and effective green-time, respectively.

$$\text{Average vehicles in queue} = N = qr + N_0$$

In the above equation,  $r$  is the effective red time, in seconds. The maximum queue length ( $N_m$ ) is calculated as follows:

$$N_m = N_0 + \frac{qr}{1-y}$$

### **Estimation of Fuel Consumption**

The program calculates estimates of fuel consumption using the following procedure used by PASSER II and PASSER IV.

$$\begin{aligned}
 F = & (A_{11} + A_{12}V + A_{13}V^2)TT \\
 & + (A_{21} + A_{22}V + A_{23}V^2)D \\
 & + (A_{31} + A_{32}V + A_{33}V^2)S
 \end{aligned}$$

- where:  $F$  = fuel consumption in gallons per hour  
 $TT$  = total travel in vehicles-miles per hour  
 $D$  = total delay in vehicle-hours per hour  
 $S$  = total stops per hour  
 $V$  = cruise speed  
 $x$  = degree of saturation ( $q/Q$ )  
 $A_{ij}$  = model coefficients given below:

$$A_j = \begin{vmatrix} 0.075283 & -1.5892E-3 & 1.50655E-5 \\ 0.73239 & 0.0 & 0.0 \\ 0.0 & 0.0 & 6.14112E-6 \end{vmatrix}$$

### **Volume Analysis Routine**

This routine uses the following analytical model developed by Chaudhary et al. [26].

Maximize:  $V$

Subject to:

$$V \leq \frac{g_i \times s_i}{C} \times \frac{1}{p_i} \quad \forall i \in E$$

$$V \leq 0.95 \times \frac{g_i \times s_i}{C} \times \frac{1}{p_i} \quad \forall i \in I$$

where:  $C$  = cycle length, seconds

$V$  = hourly flow rate (demand) for the system, vph

$g_i$  = effective green time of  $i^{\text{th}}$  movement per cycle, seconds

$s_i$  = hourly saturation flow of  $i^{\text{th}}$  movement, vph

$E$  = set of exterior movements

$I$  = set of interior movements

$p_i$  = ratio of volume for approach  $i$  to sum of exterior volumes

This model calculates the maximum number of vehicles, per hour, that can go through the facility until some movement becomes a bottleneck. It assumes that an exterior movement becomes a bottleneck when its service volume becomes equal to its capacity. For all interior movements, the bottleneck capacity is equal to a user-specified percentage (or fraction) of its capacity. The default value for internal movements is 95 percent of capacity. Furthermore, this model assumes that the origin-destination pattern does not change over the analysis period. Also, it does not consider the affects of blocking. Thus, it is especially suitable for analyzing four-phase diamonds with U-turn lanes, or facilities where sufficient internal storage space exists.

### **Bandwidth Analysis Routine**

For a given timing plan (cycle length, splits, offsets, and phase sequences), a bandwidth analysis routine (BAR) calculates the progression bands in both directions of an arterial. In its calculations, the routine calculates bands (a geometric quantity) between all signal pairs. This routine was developed for use in generating time-space diagrams, and for use by bandwidth-based optimization using the genetic algorithm. After calculating the bands, this routine calculates bandwidth efficiency and attainability using equations provided in the section describing the interference minimization algorithm. This routine is extremely efficient in its calculations.

### ***Delay Analysis Routine***

PASSER V's delay analysis routine (DAR) employs mesoscopic simulation strategy. In other words, it simulates fractional flows and updates them every second. It performs the analysis of traffic conditions using a two-step process described below:

1. initialization, and
2. simulation and recording of MOEs.

For these steps, the model uses two subroutines: the undersaturated routine and the oversaturated routine. The program conducts the initialization step for two signal cycles. The first cycle uses the undersaturated routine to get a preliminary estimate of queues, and the second cycle uses the oversaturated routine to ensure that the queue estimate is realistic.

After the initialization step, the analysis step applies the oversaturated routine for a specified number of cycles. In the current version of PASSER V, this number is fixed to two cycles. DAR uses four types of movements: external-to-external, external-to-internal, internal-to-internal, and internal-to-external.

### ***Undersaturated Routine***

This routine assumes undersaturated flow conditions irrespective of the actual conditions in the network. The routine builds flows and queue profiles by applying an extended version of the delay-difference-of-offset (DDOF) model used by PASSER III [27]. This methodology is similar to TRANSYT 7F's link-wise simulation model. In the undersaturated step, the analysis is conducted one link at a time. Starting from the upstream link, each link is simulated. The upstream flow profiles are created and projected downstream. At the downstream intersection, the outflows and inflows are calculated and queue profiles and delay profiles are built. This process is repeated for each link. During this process, the routine applies the TRANSYT 7F platoon dispersion model [14]. Queue storage on each link at the end of one cycle is obtained by building an input-output queue profile. If the queue at the end of the cycle is greater than the queue storage space, it is set equal to the storage space. The throughputs and delays for upstream and downstream movements are then calculated using flow profiles calculated using internal logic. The only exception is the external-to-external movements for which delay calculations use the *Highway Capacity Manual* (HCM) equation for calculating uniform and incremental delay [6].

### ***Oversaturated Routine***

As described above, the undersaturated routine treats a queue as an upward stack and, thus, is unable to model queue spillback and effects of any upstream blocking resulting from it. In addition, it does not account for flow interactions between adjacent links. The oversaturated routine overcomes these limitations. It uses shock wave theory to more accurately assess delays in congested conditions. The program applies this routine during the second cycle of initialization and for all full simulation cycles. The oversaturated routine conducts a second-by-second (stepwise) analysis of incoming flow at the stop line, the available queue storage in the downstream link, and the outflow from the link. It updates conditions on all links of the arterial each second. The incoming flow at the stop line for the internal movements is

obtained by applying the TRANSYT 7F platoon dispersion model. The routine uses shock wave theory to keep track of the back of the moving queue at each link on a second-by-second basis. In addition, it keeps track of the available link storage. If the back-of-queue reaches the upstream intersection, the available storage becomes 0 and movement blockage occurs until some storage becomes available. This routine performs calculations using the following steps:

1. For the first cycle (second step during the initialization period) of the oversaturated calculations, it obtains the queues stored at the end of link-wise simulation. If the queue is greater than the link storage space, it is adjusted to be equal to the link storage. DAR has the capability of keeping track of both movement-wise queue storage and lane-wise queue storage. For the initialization period, it uses the movement queue storage only.
2. Actual simulation starts using the flow profile from link-wise simulation together with the queue storage, movement storage, and lane storage from the previous step as the initial conditions.
3. It updates queue storage, movement storage, and lane storage for all links on a second-by-second basis. In the process, it applies platoon dispersion to the back of the queue and evaluates any link blockages and lane blockages.
4. It models link blockage and movement blockage, applying the second-by-second flows. This is performed by applying the following steps:
  - a. For each link, it first updates the downstream flows. For internal-to-external movements, the available movement storage and lane storage are reduced by the amount of outflow possible. For the downstream internal-to-internal movements, the outflow is updated considering the next link's available movement and lane storage.
  - b. For each direction, the internal-to-internal and external-to-internal movements for a given link are updated by obtaining the available movement/lane storage for the next downstream link. For calculating the available storage, shock wave theory is applied to find the actual available storage at each second.
  - c. If the next link is blocked, flows are stored in the current link itself.

The routine is capable of performing Step 4 for a specified number of cycles, however, in the current version of PASSER V this number is fixed to two cycles. The routine calculates and reports several MOEs at the end of simulation. DAR uses the following assumptions when performing its calculations:

- fractional flow,
- no intersection blocking,
- the only effect of queue spillback will be a decrease in flow from the upstream movements into this link,
- lane blockages are only considered when all storage space of a lane is used, and
- no right turns on red.



Lastly, DAR is limited to linear arterial systems. It is not capable of simulating networks and it is applicable to pretimed signals only. A more detailed description of DAR, along with its shock wave model, is provided by Kovvali [22].

### **Optimization and Analysis Tools**

PASSER V provides a number of analysis and optimization features for arterials and for diamond interchanges using a single controller. With the aid of this program, the user can develop timing resulting in maximum progression efficiency or minimum system delay. These features are provided under different tools. All of these tools calculate equal saturation green splits using Webster's method. Furthermore, these tools use DAR for calculating performance measures for all internal movements and the HCM delay model for calculating delay for all external movements. A description of each tool follows.

#### ***PASSER II Tool***

The PASSER II tool is applicable to a signalized arterial that contains no interchanges operating in three-phase or four-phase mode. Similar in capability to the PASSER II program, this tool allows the user to develop arterial signal timings for providing maximum arterial progression. It performs exhaustive cycle-length search in the user-selected range (lower limit, upper limit, and increment), and maximizes bandwidth efficiency for each cycle using the interference minimization algorithm. Because of this feature, a timing plan is available for each cycle length. By default, this tool reports best timings and MOEs for the optimal solution. However, the user can request the tool to report best timing plans and MOEs for all cycle lengths. In the latter case, the tool displays a summary of MOEs for all plans. It also allows the user to load into memory any selected timing plan to view the detailed results. The PASSER II tool is capable of providing perfect one-way progression for a selected direction, or two-way volume weighted bands. In addition, the user can request the tool to fine-tune offsets to further minimize delay without affecting progression bands. When a user selects this feature, the program performs bandwidth-constrained delay minimization using the genetic algorithm.

#### ***PASSER III Tool***

Similar in functionality to the PASSER III program, this tool is for isolated interchanges operating in three-phase or four-phase mode. It performs an exhaustive search for cycle length, splits, and phasing sequence, and selects a timing plan that minimizes total delay. Since it uses exhaustive search, it provides access to timings and MOEs for all combinations of timings possible based on user selected options. This tool accurately predicts delay for all types of traffic conditions as opposed to the PASSER III program, whose delay model was applicable to undersaturated traffic conditions only.

#### ***GA-Based Tool***

This tool uses a genetic algorithm to provide users the ability to time signalized arterials for maximizing arterial progression or for minimizing system delay. Depending on the optimization type selected (delay-based or bandwidth-based), it uses either DAR or BAR for calculating the fitness values of population members during the optimization process. Since each run of DAR performs multiple stages of more intense calculations than BAR, delay-

minimization requires significantly more computational time than the bandwidth-based optimization. The ability of this tool to find a good timing plan requires that the user selects large enough values for population size and number of generations. These values should be selected based on problem size (number of signals) and the number of variables (cycle, offsets, splits, and phasing) being optimized. However, the users should also note that larger values for population size and number of generations will, in general, also cause the optimization process to take longer to complete. Lastly, the users should note the fact that the bandwidth (progression) optimization capability provided by the PASSER II tool is more efficient and produces better results than the bandwidth optimization feature of this tool. Thus, we recommend GA-based tool for progression bandwidth optimization only when coordination of a diamond interchange with adjacent signals on the arterial is desired.

### ***Volume Analysis Tool***

This tool uses the volume analysis routine described earlier to provide an analysis of cycle length versus ideal throughput capacity of a facility at the point one or more movements reach maximum capacity. It provides results in graphic as well as tabular form, and identifies the bottleneck movement(s). This tool can be used for isolated diamonds, arterials, or a combination of the two. The reader should recall that interior distance (travel time) of a diamond interchange is explicitly taken into account for calculating the timings for a four-phase diamond. Hence, for isolated diamonds, this tool provides a “planning” option that can be selected to investigate the distance versus capacity issue of the TTI four-phase strategy.

### ***T-Sp Diagram Tool***

This tool displays a time-space diagram (TSD) for the currently loaded timing plan. A TSD is a scaled pictorial representation of an arterial roadway and the progress of time in relation to signal timing cycles. It is usually presented in the form of an X-Y graph. In PASSER V, the distance along the arterial is displayed on the Y axis (in scaled, consistent units) and time on the X axis (in scaled, consistent units). TSDs give the analyst the “big picture” of traffic operations and signal timing at each intersection along an arterial. The slope of each line represents the speed of travel necessary to achieve the green bandwidth shown. TSDs can be formulated for interchanges as well, either to show the progression along frontage roads or to show the progression that exists along the arterial roadway (through the interchange). The T-Sp Diagram tool identifies the source of timing plan being displayed. Furthermore, it also provides access to the detailed report. This feature is especially useful when the timing plan has been manually adjusted. The user should note that the Redraw button must be clicked for the tool to display changes made to any offset, and for the tool to generate the report.

### ***Delay/Cycle Analysis Tool***

This tool calculates and plots delays estimated by DAR (PASSER V's mesoscopic simulation) and HCM models for all cycle lengths in the user-defined range. For using both models, it assumes that all signals operate under a common cycle length. For each cycle length, it first calculates green splits for all signals. For the first set, it uses the HCM model to calculate average delay for each signal. Then, it adds average delays for all signals to

determine the total system delay. For the second set of calculations using DAR, phasing sequences and offsets are also required. In this case, the tool uses current phasing sequences at all signals. For offsets, the tool provides two options. If the user desires the absolute offsets to remain the same as those entered on the data screen, the tool uses the same offsets for all cycle lengths. However, if the user selects the “Proportional offset,” the tool recalculates the offset of each cycle in proportion to the change in the cycle length from that coded for a signal on the data screen.

### **Program Limitations**

PASSER V analysis and optimization capabilities are limited to pretimed signal-controlled intersections with three to eight signalized approaches. The program currently supports controllers with two rings and multiple barriers only. In addition, all analysis and optimization of multiple signals (diamonds or arterials) assumes that the signals in the system operate under a common cycle length. The program does not support double/half cycling or conditional service.

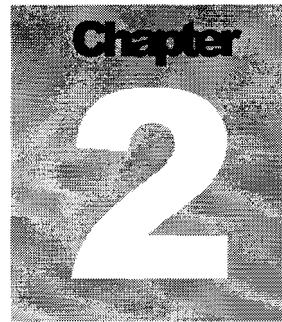

## Data Requirements

*All the things you need to know about the arterial (and diamond interchange) before you can start to analyze it.*

**R**emember the maxim for analytical procedures: “Garbage in, garbage out.” It is essential to the integrity of any analysis that the input data are up-to-date, accurate, and representative of general conditions. This is especially important with traffic engineering information in that signal timing, a primary output of the process, has a direct bearing on safety and efficiency for the motoring public.

In Chapter 2 we will talk about the types and quantities of data that you will need to perform an analysis and optimization of an arterial roadway. These data include traffic volumes, roadway geometrics, and any available information about current signal timing and operation.

### Traffic Volume Information

A peak hour turning movement count (TMC) for all intersection approaches is often the most useful intersection data for purposes of developing a signal timing plan. TMC data are often supported by average daily traffic (ADT) counts, which are 24-hour counts along the intersection approach roadways. ADT counts may cover a single direction or both directions, and usually cover all traffic lanes in a given direction. Pedestrian counts may be performed simultaneously with TMCs, or may be collected as a separate study. It may also be desirable to collect truck data.

#### Turning Movement Counts

TMC data are collected using a variety of techniques. The most common method is to dispatch a technician to visit the site and conduct the count while in the field. A variation on this method would be to have the technician videotape the intersection (including portions of each approach roadway), return to the office with the videotape, and perform TMCs from the video. The video creates a permanent record of intersection operations and can also be used to determine the current signal timing at the intersection.

TMC data are most useful for peak periods of the day, with data collected in two-hour blocks that bracket the peak hour. For instance, a common PM peak hour would occur from 5:00 PM to 6:00 PM, so a good data collection bracket would be between 4:30 PM and 6:30 PM. TMC information (i.e., number of vehicles turning left, through, and right) is often collected using manual or computerized counters in 15-minute increments. Each 15 minutes of data is transferred from the counting device to a computer program or a written sheet. Data for all intersection approaches must be collected simultaneously, so it is often necessary to have more than one technician at the intersection at one time (each person counting two approaches).

Once the data have been assembled from each approach for the entire intersection, a calculation is made (from all approaches) to determine which 15-minute periods have the highest volume. The following table shows data from a four-leg intersection, with an intersection total volume in the right column. The peak hour is determined from the highest four **consecutive** 15-minute periods. In the table, the highest (peak) hour is from 4:45 to 5:45 PM. Data sheets may contain more data than are shown in the example table. The example shows the minimum amount of data necessary to determine the peak period and perform an analysis. An example of more detailed information would be a separate count for automobiles and trucks (heavy vehicles). Under each Left, Thru, and Right heading there would be two columns – one for autos and one for trucks – instead of the one column of numbers shown in the example.

Time (PM)	Northbound			Southbound			Eastbound			Westbound			Total
	Left	Thru	Right	Left	Thru	Right	Left	Thru	Right	Left	Thru	Right	
4:30-4:45	10	35	10	10	35	10	10	35	10	10	35	10	220
<b>4:45-5:00</b>	<b>15</b>	<b>40</b>	<b>15</b>	<b>15</b>	<b>40</b>	<b>15</b>	<b>15</b>	<b>40</b>	<b>15</b>	<b>15</b>	<b>40</b>	<b>15</b>	<b>280</b>
5:00-5:15	20	45	25	20	45	25	20	45	25	20	45	25	360
5:15-5:30	20	50	25	20	50	25	20	50	25	20	50	25	380
5:30-5:45	20	55	25	20	55	25	20	55	25	20	55	25	400
5:45-6:00	10	40	15	10	40	15	10	40	15	10	40	15	260
6:00-6:15	5	20	5	5	20	5	5	20	5	5	20	5	120
6:15-6:30	25	30	5	25	30	5	25	30	5	25	30	5	240
<b>Peak Hour Total (4:45-5:45)</b>	<b>75</b>	<b>190</b>	<b>90</b>	<b>75</b>	<b>190</b>	<b>90</b>	<b>75</b>	<b>190</b>	<b>90</b>	<b>75</b>	<b>190</b>	<b>90</b>	<b>1420</b>

An important item to consider when performing your analysis is how volumes peak within the day and within the peak hour itself. Notice that the total intersection volume between 5:30 and 5:45 PM is 400 vehicles. However, the volume between 4:45 and 5:00 PM is only 280 vehicles. Both values are within the peak hour, but there is a sizeable difference between them. The average 15-minute volume is  $(280+360+380+400)/4 = 355$  vehicles per 15 minutes. An indicator known as the peak hour factor (PHF) is computed as the peak hour counted volume divided by four times the highest 15-minute volume. Thus,  $(1420)/(400 \times 4) = 0.8875$ . PHF can range from 0.25 to 1.00. A PHF of 0.25 would indicate that all of the hourly traffic occurs within a single 15-minute period (very unlikely). A PHF of 1.0 would indicate the hourly traffic was evenly distributed among the four 15-minute periods (also unlikely). The smaller the PHF is, the more likely that your timings

should be longer (i.e., require a slightly longer cycle length or longer splits for approaches that peak heavily) than otherwise indicated by the total peak hour volume.

**Key Point:** The peak hour factor (PHF) is a measure of how much volumes vary within the peak hour. When the PHF is less than 0.85, you should account for volume variations within the peak period when you are computing your signal timings.

### Average Daily Traffic

ADT information is a valuable resource for checking the accuracy of peak hour TMCs, checking for the location of the peak hour for each intersection approach, and monitoring increases in overall traffic volume over time. The figure below shows a hypothetical intersection and hourly counts that develop the one-way ADT counts for each intersection approach roadway.

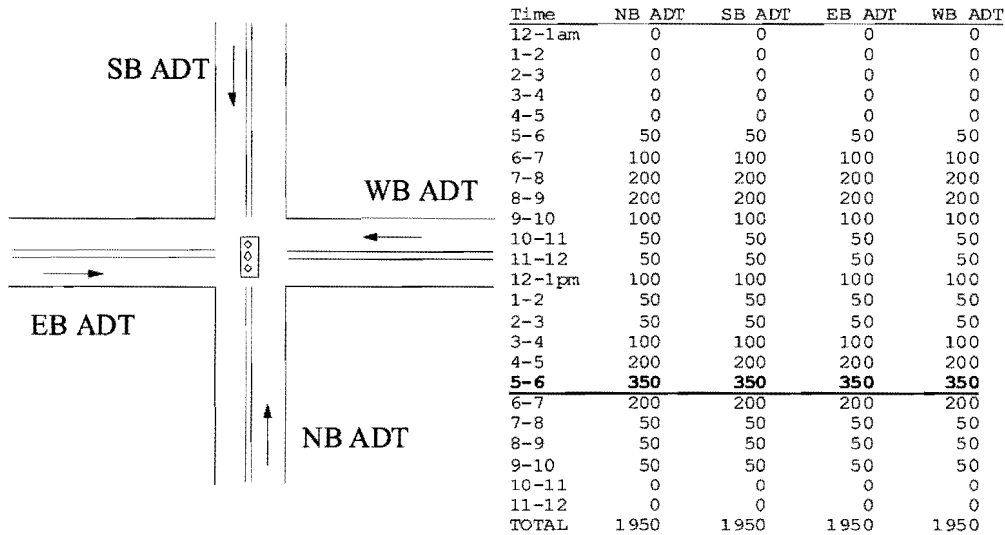

Examination of the hourly figures used to calculate ADT confirms that the 350 vehicles counted from each direction are roughly the same as the TMC numbers shown for about that same time period (5:00 to 6:00 PM). This check helps validate that neither the TMC values nor the ADT values are out of scale with representative values. The high count for the hour from 5:00 to 6:00 PM also shows that the hourly volume used to compute ADT numbers indicate what we already discovered – that the PM peak is somewhere around the 5:00 to 6:00 PM range, and it turns out from the TMC that the actual peak is from 4:45 to 5:45 PM.

Another valuable use for ADT values is to examine the rate of traffic growth over time. If we had counted ADT from the northbound (NB) direction in our example once every year between 1993 and 1997, we would have five data points for checking growth rates over time. The table below presents hypothetical traffic counts over this time period.

<b>Year</b>	<b>NB ADT</b>	<b>Percent increase over previous year</b>
1993	1700	-
1994	1800	5.9 %
1995	1850	2.8 %
1996	1900	2.7 %
1997	1950	2.6 %

As seen in the table, the volumes constantly increase (though at different rates and volumes) over time. Between 1993 and 1994, volumes increased 5.9 percent, but between 1996 and 1997, volumes increased only 2.6 percent. It is reasonable to calculate an average annual growth rate, which in this case is  $(5.9+2.8+2.7+2.6)/4 = 3.5\%$ . Thus, ADT history has given us a good estimate of how much ADT is likely to increase in the next couple of years.

A useful equation for computing compounded growth rates (i.e., those that grow and build upon each other from year to year) and future volumes is:

$$\text{Future Volume} = \text{Present Volume} \times (1.00 + r)^n$$

where:  $r$  = annual growth rate (i.e., 5% is expressed as 0.05)

$n$  = number of years for the traffic projection

This equation should only be used when historical traffic volumes have shown a consistent, compounding increase over time (i.e., an exponential increase).

It is important to note that a traffic count (TMC or ADT) is never an exact count. Not only are errors often made in counting and recording, but traffic volumes themselves are never consistent from day-to-day, week-to-week, or month-to-month. For instance, even in an area where traffic is not growing, a count performed in February will be much different than a count performed in July. If historical records of traffic volumes and month-to-month average ADT variations are available, this information can be used to “calibrate” your recent count information to account for month-to-month variations. For instance, historic monthly records may show that counts in your area tend to be 1.15 times higher in July than in February, and July tends to be the busiest month of the year. To cover all cases (i.e., use the maximum reasonable traffic volumes in your signal timing analysis), you would multiply your TMC and ADT counts by 1.15 to produce a reasonable estimate of the highest volumes expected throughout the year. Since signal timings are usually changed only once every few years, it is important to account for month-to-month variations in your analysis. If you used only your February values in your analysis and computed signal timings from

those volumes alone, there may be large amounts of delay at your intersection in July because the signal cycle lengths and splits could not accommodate the increased volume.

**Key Point:** Use your knowledge of how frequently your signal timings will be updated to frame your analysis. If timings are changed infrequently, you should consider applying factors for monthly variation to volumes used in your analysis. Use maximum likely peak hour volumes to compute peak hour timing. If volumes in your area are increasing rapidly, it will be necessary to update your count data and signal timing more regularly.

## Roadway Geometric Information

A complete understanding of roadway features is just as critical as accurate traffic volumes when the goal is signal timing generation. As we have seen in the saturation flow computations in the theory section of this training guide, factors ranging from mixed use lanes (lanes where through and turning traffic are both present) to driveway spacing from the intersection have an impact on how efficiently a lane, approach, or intersection can process vehicles. The most appropriate way for the signal analyst to determine the presence and extent of these factors is by visiting the site and taking the time to observe the operation of the intersection(s)/interchange. All significant roadway and intersection details should be noted, including (but not limited to) these common items:

- lane use by lane for all approaches and departures;
- lane widths by lane for all approaches;
- roadway names;
- number of lanes for each approach and departure;
- type of intersection approach lane striping for all approaches;
- lengths of turn bays along each approach and departure;
- turning radii within the intersection (field approximation);
- presence and location of stop bars;
- presence, location, and size of protective islands;
- presence, location, and type of signal heads and pedestrian push buttons;
- presence and location of pedestrian crosswalks;
- pedestrian walking distances (see Chapter 1);
- north arrow;
- adjacent land use;
- presence and location of roadside angled or parallel parking;
- distance to nearest driveway upstream from the intersection on each approach and departure; and



- spacing between intersections, measured from the stop bar of the upstream intersection to the stop bar of the downstream intersection along a given roadway link (if the analysis is not for an isolated intersection).

Some factors may not apply to all cases, but the above list includes most significant roadway details. The figures below are examples that show most necessary information for an intersection and an interchange, respectively.

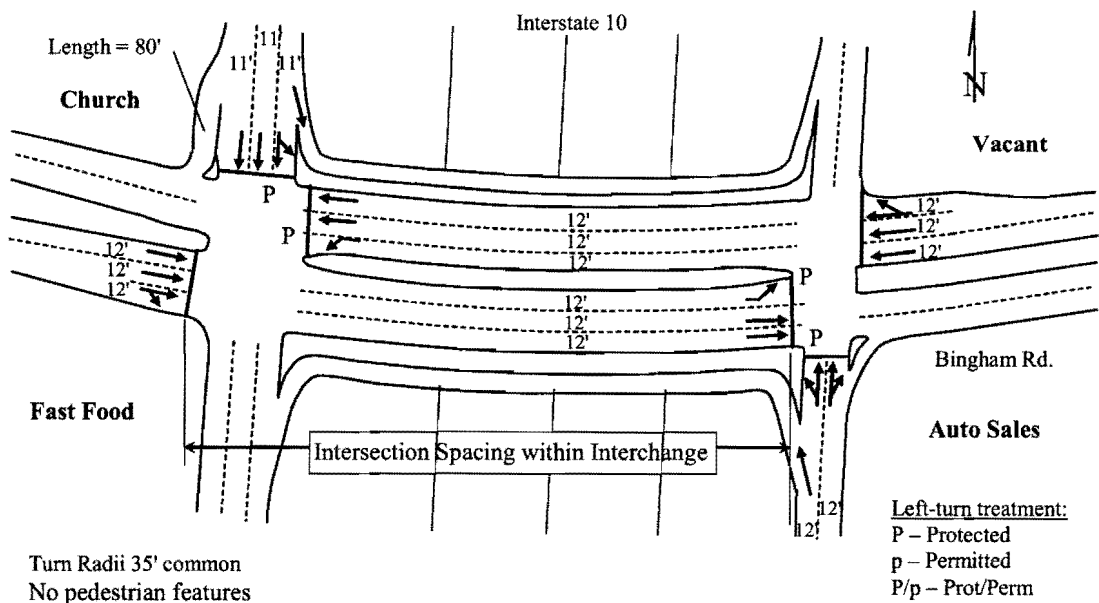
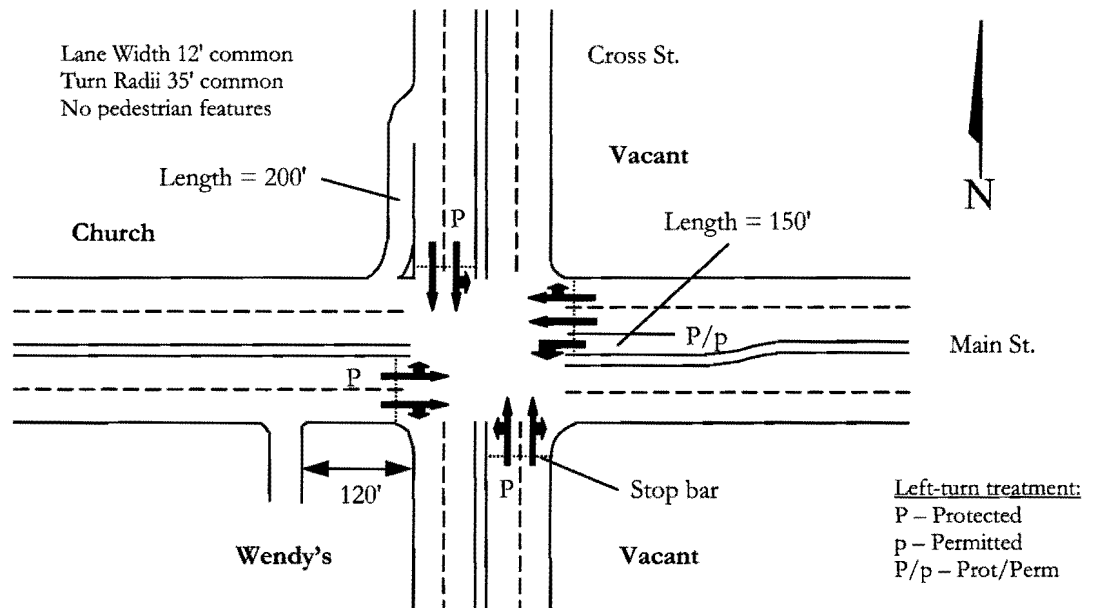

An important roadway measure statistic not shown in the figure above is the spacing between signalized intersections along a given roadway to be analyzed. This information is necessary if coordination is intended or possible between two or more intersections. The distance is measured as the length along the roadway between the stop bars of successive intersections. The figure below highlights the required reference points for this distance.

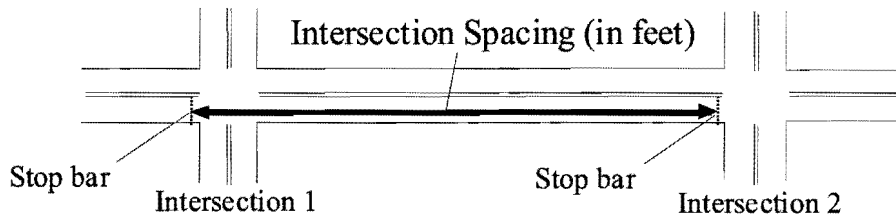

An additional consideration in examining diamond interchange geometry is thorough documentation of interior geometry and how the interior is “fed” by the arterial approaches to the interchange. The interchange’s ability to process left turns is influenced as much by the arterial approach geometry and left-turn storage space as it is by the lane assignment and storage space in the interior. The figure below illustrates important points to consider.

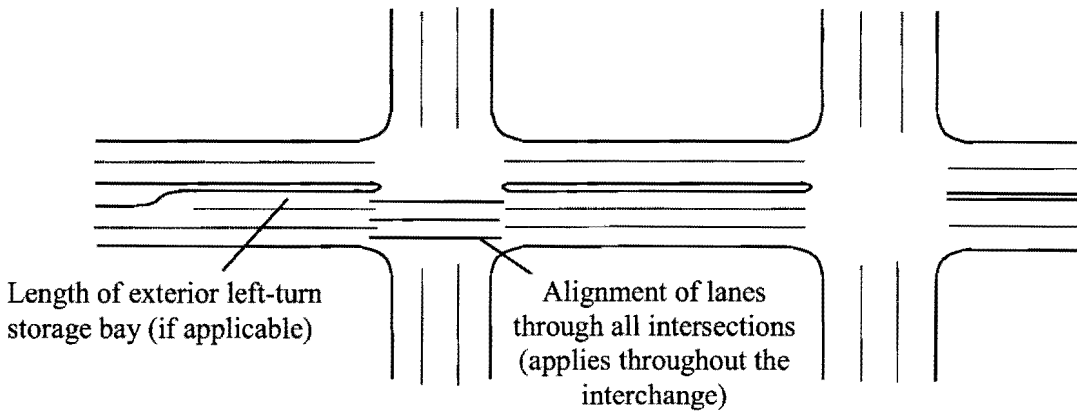

## Signal Timing Information

Several important details about an intersection’s/interchange’s signal timing are essential for analyzing existing conditions. An engineer must also consider the capabilities and features of the control hardware in the field prior to strategy development. Other details about the interchange include the type of infrastructure at the intersection, which includes: signal heads, controller cabinets, and other devices.

### **Left-Turn Treatment**

The presence of a designated left-turn bay within the interior of the interchange allows special consideration to be given to this movement. Observation of the intersection in the field will reveal its current mode of operation.

The left-turn bay may be controlled with either a three- or five-section signal head. A separate three-section head limits the type of phasing to either protected or permitted only. A five-section signal head display will allow a protected/permitted left turn which can be used to increase the performance and flexibility of the approach. Field observation of left-turn operations will verify the type of operation. If no separate indication for left-turn vehicles exists (i.e., the only signal heads for each approach are the two, three-section heads called for by the MUTCD [1]), permitted operations are virtually always present unless signing indicates that there is a protected turn on green (i.e., no conflicting vehicles are present, as in “split phase” operation). If a left-turn treatment of a particular type is desired and the hardware and/or geometry are not capable of accommodating the required display, either the timing strategy will have to be changed or new hardware or geometry will have to be installed in the field.

### **Mode of Operation**

Current practice for signalized intersection timing calls for the use of one of three methods: pretimed, semi-actuated, or fully actuated control. The type of controller affects the type of timing plan that can be implemented. The timing strategies that may be applied are a function of the type and capability of the controller and the operational requirements of the intersection [28]. Most new controllers are actuated controllers that can execute any of these types of control.

Basic pretimed, also known as fixed time, strategies can be used when traffic at the intersection is relatively steady day to day. These plans utilize a fixed cycle length, phase sequence, and phase lengths to serve traffic. Different timing plans may be programmed to deal with fluctuations in traffic volume throughout the day and to implement patterns that will serve traffic demands. A consistent cycle length and a continuous repetition of the same sequence of signal indications characterizes pretimed operation. The cycle times and phase splits are easily measured and recorded using a stopwatch. If an interchange is currently operating in pretimed mode, it may not have vehicle detectors that are required for actuated operation. Pretimed solutions are effective where volumes follow repeatable patterns.

Semi-actuated control is characterized by a background cycle length that, as with pretimed mode, can be measured using a stopwatch. The difference in comparison to pretimed mode is that some phases may be skipped, shortened, or lengthened depending on how many vehicles are queued over the loop detectors for each phase. What is consistent from cycle to cycle is the cycle length and the fact that the main street through phases (i.e., phases 2 and 6) will always appear in the phase sequence. A uniform reference point for measuring the cycle length is the beginning of the phase 2 or phase 6 pedestrian “DON’T WALK” indication. A stopwatch measuring the time from the beginning of the phase 2 “DON’T WALK” of one cycle to the beginning of the phase 2 “DON’T WALK” indication of the next cycle has

recorded the cycle length of a semi-actuated controlled intersection. The beginning of the phase 2 “DON’T WALK” is also the offset reference point. The offset between the coordinated intersections is the difference in time between the start of phase 2 “DON’T WALK” at one intersection to the start of phase 2 “DON’T WALK” at the next intersection. If “DON’T WALK” indications are not present, reference the beginning of the phase 2 yellow interval.

Actuated control is used at locations where traffic is less predictable and where demand can vary significantly. Actuated control utilizes input from detectors and logic within the controller to adjust green times to serve demand inputs. The standard eight-phase controller with an actuated control strategy allows the use of phases in any sequence provided opposing movements are separated. The signal controller can also omit phases if detectors indicate no demand for a particular movement. This capability can benefit the competing movements and the entire intersection by reducing the time required for servicing the movements with demand. The main advantage of actuated control is that the cycle length is allowed to vary to meet traffic demands. Reduced cycle lengths are desirable attributes for isolated interchange control [5].

Fully actuated mode operates without the constraint of a fixed cycle and can only be implemented within a single controller. Phase start and duration are determined by the presence of vehicles over loop detector sensors in the pavement. Internal controller logic maintains a background phase pattern, called a ring structure, so conflicting movements are not displayed simultaneously. A phase is initiated by the detection of a vehicle over the approach sensor. This initial detection provides a minimum green for the movement. As the detector continues to collect demand, vehicles activate the detector and “calls” are placed to increase the green time, or phase time, by a given amount of time, known as the “passage time.” This process is continued until there is a sufficient gap in the demand to warrant ending the phase, or the maximum green time is reached. At this time, this phase will terminate (through yellow change and the all red clearance) if there are vehicles waiting on conflicting approaches. If there are no vehicles waiting on conflicting phases, this phase will remain green until the time that a vehicle does pass over a detector on a conflicting phase. This type of a system is heavily dependent on the detectors for operation. If detectors fail, it will be necessary to adjust the controller to always cause a phase to display (i.e., be set to “recall”) for at least the minimum time for each phase experiencing detection failure.

## **Speed and Travel Time**

When analyzing multiple signalized intersections and/or interchanges, it is necessary to have information not only about the length and features of roadways that join the intersection(s)/interchange(s), but also about the speed of travel between the signalized junctions. In the case of PASSER V, such information is required when analyzing an artery with adjacent intersection, when analyzing an interchange, or when analyzing these elements in combination. Note that for purposes of coordinating intersections (rather than documenting system performance, which is mentioned later), the speed information

collected should be based only on driving that occurs at a driver's average chosen speed in traffic (i.e., it should not include delay at signals).

The simplest technique for collecting speed data along the artery is to simply select vehicles in the traffic stream at the site and, using a stopwatch, time how long it takes each vehicle to travel from stop bar to stop bar at successive intersections. Combining this time information with knowledge of the distance between the intersections allows you to easily compute the speed. Of course, this requires that line of sight exists from a safe vantage point to the same-direction stop bars at adjacent intersections.

The average speed between intersections can also be obtained using the floating car technique, though this requires much more data collection planning than the observation method. The floating car study is based on the average speed found to exist between two points by traveling within or following platoons of vehicles. The average speed is estimated from five to ten trial runs during off-peak traffic volume conditions and five to ten trial runs during each peak period condition. The speeds obtained should be free flowing speeds of platoons between stop bars at successive intersections. Trial runs during both off-peak and peak periods should be made to determine if different average speeds occur. Floating car speed studies are safely performed having two persons in the study vehicle; one person to concentrate on the driving, and the other person to record travel time information.

Usable speed information can also be obtained from a speed study performed in the middle of the block between the study intersections. A variety of devices can be used to collect such data, including radar guns, traffic counting devices, and microwave traffic detectors. If no other information is available or can be collected about the average speed between intersections, the posted speed limit should be recorded and used in analyses.

Note that speed and/or travel time data are also required between the two intersections that make up any interchanges that you analyze. The best methods for collecting travel time information between the stop bars of the two interchange intersections are the observation/stopwatch technique and the floating car technique.

The final speed elements that pertain to intersections and interchanges are the speeds (and travel times) between arterial intersections and the diamond interchange that are needed for diamond-arterial coordination.

## **Additional Information**

In addition to the above classes of information, which are primarily designed around the input information required by traffic analysis software, there may also be a need to collect information about how well the current system is operating. These data may be collected to determine the level of service (LOS) of the existing arterials or intersections, to calibrate and compare against results produced by the analysis tool, or to document the overall impacts of mobility (i.e., overall fuel consumption or emissions information). Typical studies

performed for these reasons include delay studies, which involve recording the number of vehicles in queue for each intersection approach at a set time interval; travel time studies, which usually involve driving a probe vehicle along the study arterial and either manually or electronically recording travel time between intersections; or a combination of both of these studies to gain an overall understanding of arterial system performance. Detailed information about performing both types of studies can be found in the *Manual of Transportation Engineering Studies* [29].

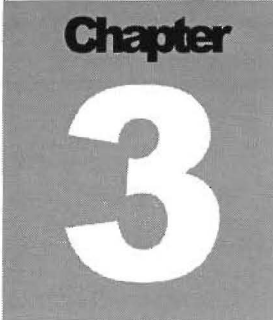

A dark gray square graphic with the word "Chapter" in a bold, black, sans-serif font at the top. Below it is a large, white, stylized number "3".

# Chapter 3

## PASSER V - 2003

*An easy-to-use Windows graphical user interface allows you to quickly analyze arterials and/or diamond interchanges with this new software.*

In this chapter we will discuss the PASSER V program's user interface and the optimization features of the software. With its broad range of applicability, PASSER V can be considered an upgrade and replacement for the PASSER II and PASSER III programs that precede it, in that PASSER V contains the analytical capabilities of both tools. In addition, PASSER V contains a number of new analytical tools that will provide further insight into the traffic engineering operations problems you analyze.

### Installing PASSER V

Install PASSER V on your computer by inserting the PASSER V CD in your CD drive and allowing the installation process to execute automatically. If the installation process does not begin automatically, navigate to your CD drive using Windows Explorer and double-click on the 'setup.exe' file. Once the installation process begins, a splash screen appears with the Texas Transportation Institute (the program's developer) logo. Click on 'Next' to advance to an installation screen telling you to exit other applications before installing PASSER V. After exiting other open applications, click 'Next.'

At the next screen, enter your username and company name, followed by a click on 'Next.' The default folder for PASSER V installation is C:\PASSER V-03. It is recommended that you retain this default install folder and click on 'Next.' The next screen will tell you that PASSER V icons will be inserted into a program folder that the installation program creates (named Passer V-03). Once again, retain the default values and click on 'Next.' At the next screen, confirm your installation settings and click on 'Next.' The installation process will copy the PASSER V files onto your computer and install the program in Windows. The final installation screen you see will be a screen indicating the install is complete and asking if you would like to launch PASSER V as soon as you close the installation program.



## Running PASSER V

When you are ready to begin working with PASSER V, click on Start | Programs | Passer V-03 | PASSER V-03. You will see a screenshot like the one below. This is the primary PASSER V work area, and it contains a primary file menu bar, a file access toolbar and a PASSER V function toolbar. The buttons on these toolbars provide all of the functions you need to create, edit, enter data for, and analyze signalized isolated intersections, intersections along an arterial roadway, and diamond interchanges.

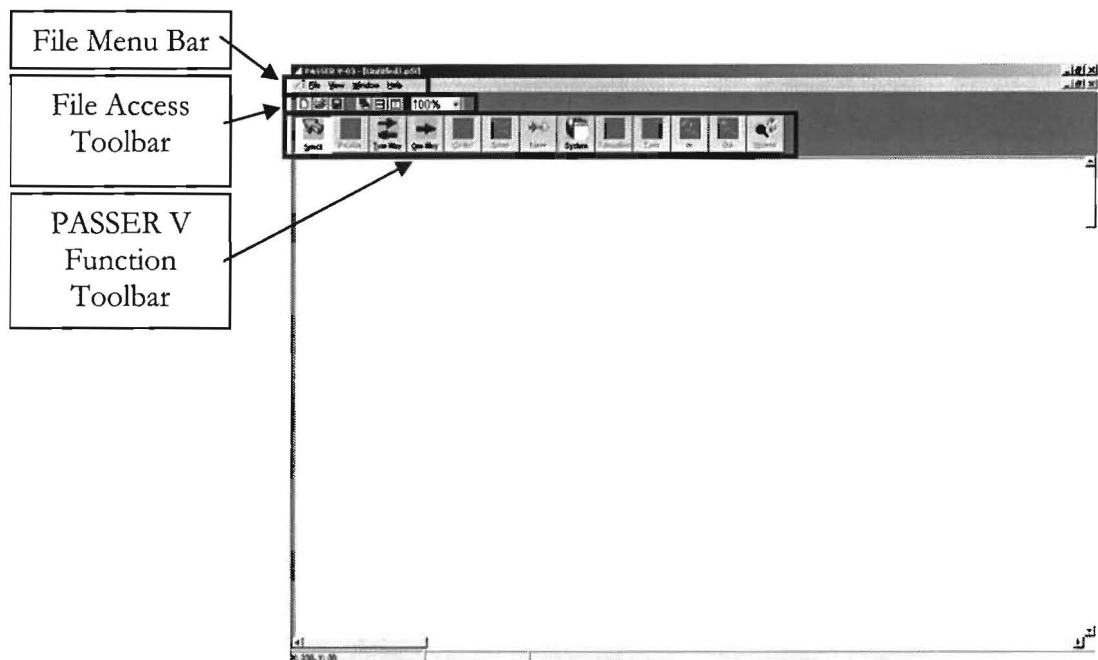

### File Menu Bar

The PASSER V file menu bar contains the headings File, View, Window, and Help. From the File menu, you can start a new PASSER V file, open an existing file, close the current file, save the current file, or save the current file under a new name. With an active analysis case open in PASSER V, you can also print a hardcopy of the current window or create a report on your analysis. The final function accessible is the option to exit the program.

The View menu allows you to show/snap to the grid, set the grid point spacing, adjust drawing speed, toggle on/off the view of node and link identification numbers, and zoom in and out of the PASSER V network editing window. The Window menu comes in handy when you are analyzing multiple projects simultaneously in PASSER V. With functions under this menu, you can minimize or arrange the windows for each analysis problem, or select the desired problem from the list of open files. Finally, the Help menu allows you to access the contents or index of the online help system, access the developer's homepage (which contains up-to-date information about PASSER V), and view information about PASSER V.

## File Access Toolbar

The PASSER V file access toolbar is designed to make it easy for you to close, open, and save files. Additional buttons allow you ease of control over the way multiple projects/files are arranged in the PASSER V view window. By button click, you can choose to have multiple open files arranged in a cascade, horizontally, or vertically. The last item accessible under the file access toolbar is a zoom control, where you control the percentage of zoom, from 25% (zoom out) to 400% (zoom in).

## PASSER V Function Toolbar

The final menu button bar is the PASSER V function toolbar. When starting a new file, the only accessible buttons are the Select, Two way, One way, and System buttons. The first data elements you should enter are available under the System button. Within the pop-up window that appears after you click on System, enter the project, agency, city name, state, and your name (as the analyst), and specify a run number. Under the Defaults tab, you can change average vehicle length, the feet per pixel represented in the PASSER V network editing window, the default cycle length range for your analysis and, eventually, the unit system you prefer (metric units are not yet supported in PASSER V). Note that it is necessary to click 'Update' to register the information you enter in PASSER V's input file.

The Two way and One way buttons are used to create a representation of your network. Wherever two-way or one-way segments intersect, PASSER V will automatically create an intersection. Thus, the normal procedure is to draw the primary artery in the PASSER V window, and then follow by creating the appropriate number of cross streets. Use the PASSER V grid to approximate the location of your cross roadways when you first draw them. Notice that as you add roadway elements, additional buttons become accessible on the PASSER V function toolbar (see screenshot below). The Select and Move buttons can be used to update/correct link lengths and/or intersection locations.

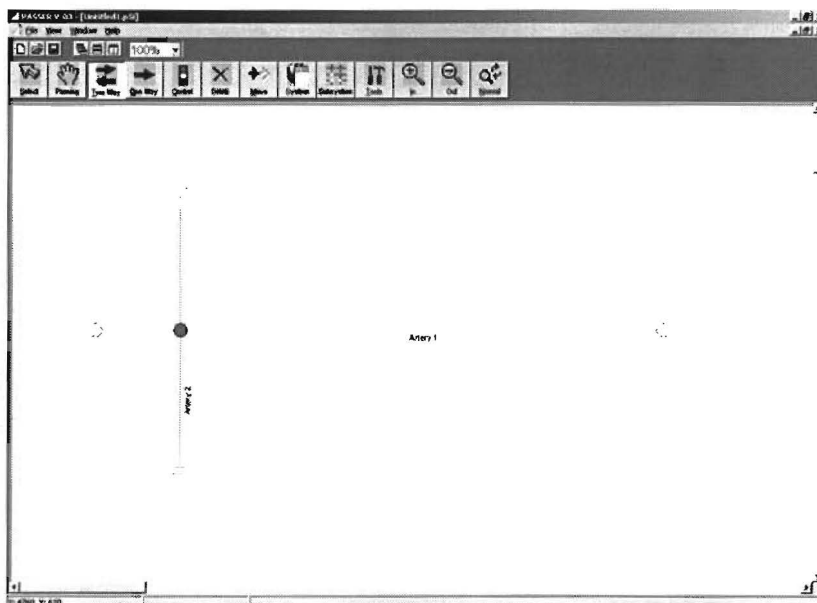

Notice by clicking on 'Select' and then clicking the mouse pointer over a node or link that you are presented with node or link information. In the case of a node, you can change the node's identification number and/or its x- and y-coordinate information. Nodes that are displayed in red indicate that the node is either missing required input data (volumes, signal settings, etc.) or that there is a logical problem with the data entered for the node (i.e., sum of minimum green times for all phases is greater than the lower cycle length bound).

For links, you can edit link length (from stop bar to stop bar), the travel speed along the link, intersection width, and link queue storage length (link length less the intersection width) for each travel direction. Keep in mind that the "drawing" of your network will remain the same (i.e., it is representational rather than "to scale"), even if you edit and change a link's length. Also, if you have manually edited a link to change its length and then you go back and move one of the nodes for that link, PASSER V will automatically recalculate a scaled length for the link. You will have to go back and re-edit the link length to re-enter the value you manually entered the first time.

Once PASSER V has automatically created nodes at link junction points, you can select the Control button from the PASSER V function tool bar and click on a node (see figure below). It is within the Node Data window that appears that you enter the majority of the intersection volume, geometry, and signal control information for each intersection of your network. For each node, you specify the cycle length (usually left as the default value, and PASSER V will perform a cycle length analysis over the range of cycle lengths you specified earlier), offset (usually left blank for optimization), and area type where the signal is located. Next, you select the lane use/permitted movements from each lane, specify your input movement traffic flows, and select desired controller settings from the tabs provided within the Node Data window. Finally, you can choose to view a delay versus cycle length analysis for this intersection (after you have entered the required input data) or check on output MOEs for this intersection.

**Node Data**

Controller Id: 3    Nodes In Controller: Node 3    Controller Type: NEMA 2    Cycle Length: 90  
 Area Type: Other    Offset Ref:    Offset: 0

Timing Data | Sat. Flow Data | Optimization Data | Delay vs. Cycle Analysis | Controller | Signal MOEs

Movement	EBL	EBT	EBR	WBL	WBT	WBR	SBL	SBT	SBR	NBL	NBT	NBR
Lane Assignment	3	0	0	0	0	0	0	0	0	0	0	0
Volume (vph)	100	100	100	100	100	100	100	100	100	100	100	100
Movement Type												
Left-turn Phasing												
Overlap?												
Minimum Green (sec)												
Yellow (sec)												
Red Clearance (sec)												
Lost Time (sec)												
Green Splits (%)												
Green Spills (sec)												

Optimization Settings:  
 Lock Sat Flows   
 Lock Green Spills

Update    OK    Cancel

If you are entering data for more than one artery at a time, your network may resemble the one shown in the following figure. Keep in mind that even though you can enter data for all of the intersections in such a network, PASSER V will only analyze them on an artery-by-artery basis.

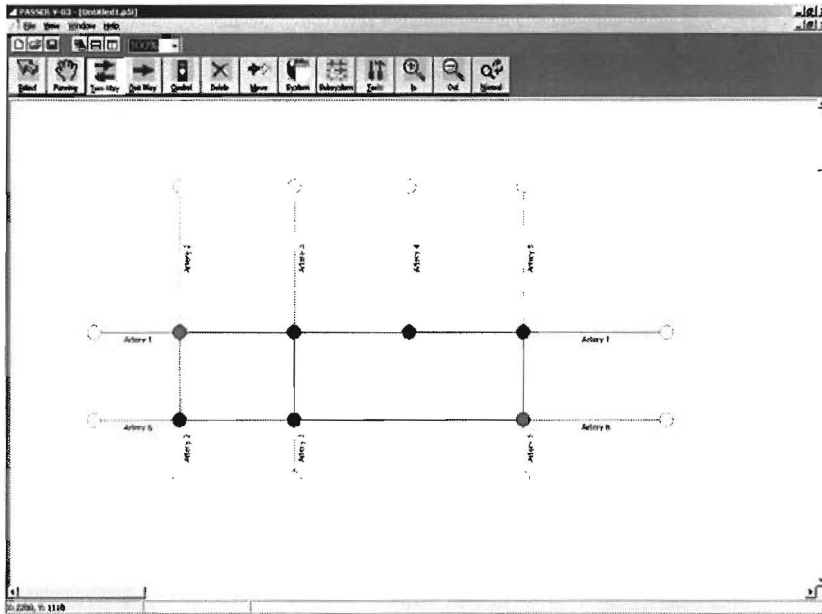

If you do choose to code multiple arteries at once, you may find it helpful to click on the Subsystem button from the function bar. A window/dialog box similar to the one below will appear. By clicking on an artery name within this artery listing, you can see how PASSER V is organizing your network into arterials. The selected arterial will be highlighted in red within the PASSER V main view screen if you click on 'Show' within the Subsystem window.

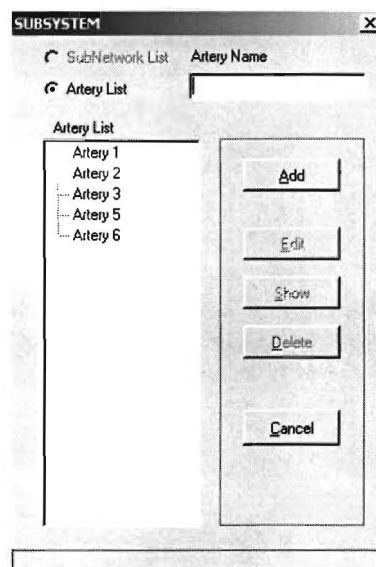

You can also use the Subsystem button/menu to create “groups” of signals within an arterial. You might organize by groups to create logical groupings of controllers to mirror the way that your controllers are connected/coordinated in the field or to allow for different cycle lengths/coordination plans along different portions of any given arterial roadway. To create a subsystem, simply type in a name for the grouping next to Artery Name in the Subsystem dialog box and click ‘Add.’ Then, click on each link that you want to include in the new subsystem you created, right-clicking the mouse when you are finished. As you create a subsystem, note that subsystems can only be composed of the links along one arterial roadway (i.e., subsystems are subsets of selected links along one artery). When you have finished the process of creating a subsystem, you can click on the Subsystem button again. You will notice that the artery along which you created a subsystem has a “plus” sign next to its name. Clicking on the plus sign will expand the subsystem listing (see figure below).

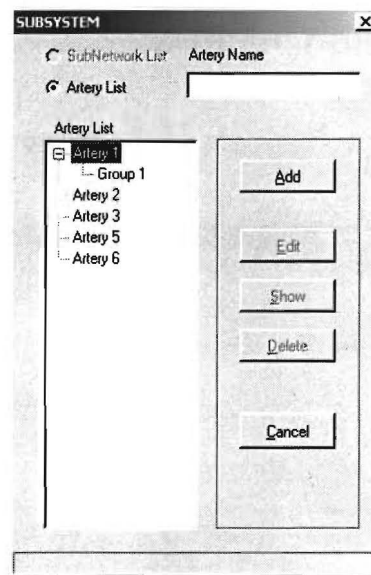

Once you have completed data entry (traffic volumes, geometric details, signal parameters) for each intersection along an artery, the nodes for that artery should appear in light blue (versus red). If you think you have finished entering data for each node but one or more nodes remain red in color, review your input data for internal consistency. For example, is the sum of the minimum phase times greater than the lower bound of your cycle length range? Remove inconsistencies or coding errors until all nodes are ready for analysis (i.e., light blue in color).

When you are ready to perform your optimization on your artery/arteries, click on the Tools button of the PASSER V function toolbar. From the dialog box that appears you can select the first arterial or subsystem from the list on the left side and then choose the type of analytical tool you want to use. If you are analyzing an arterial or subsystem (where no sections are specified as a Texas diamond interchange), the tools available include PASSER II, GA (Genetic Algorithm) Optimizer, Volume Analysis, T-Sp (Time-Space) Diagram, and Delay/Cycle (Length) Analysis (see next figure).

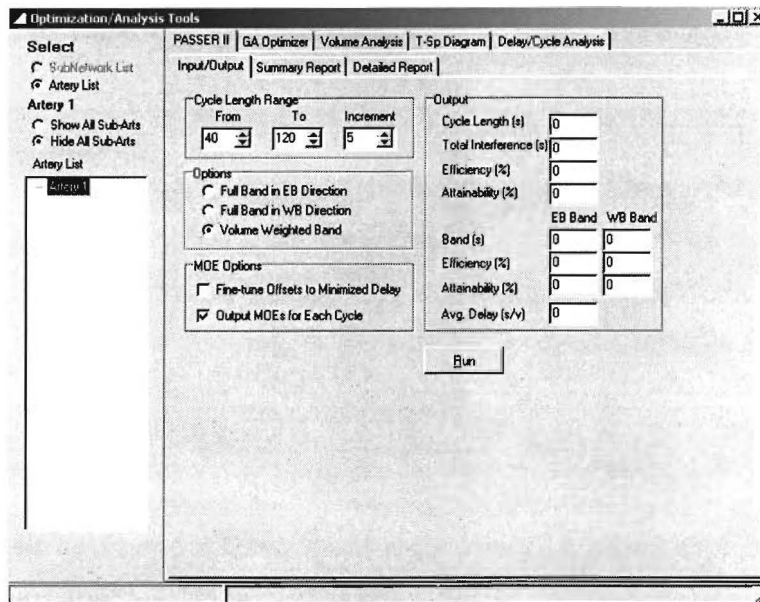

If you choose the PASSER II tool, you will need to specify a cycle length range and an increment for successive runs. You will also need to specify the type of bandwidth (progression) you wish to establish, indicate whether or not you want PASSER II to try and fine-tune offsets to minimize delay, and indicate whether you want PASSER II to output MOEs for each cycle length analyzed (or just for the optimal cycle length). After specifying all of these details, clicking on 'Run' will execute the PASSER II optimization engine and produce your output. A Summary Report is available to give general summary details (bandwidth, efficiency, attainability, delay, stops, etc.) for each cycle length analyzed, and a detailed report includes intersection-specific optimal signal settings and MOEs. Clicking on the T-Sp Diagram tab at this point will produce a time-space diagram for your PASSER II best-efficiency solution (see below).

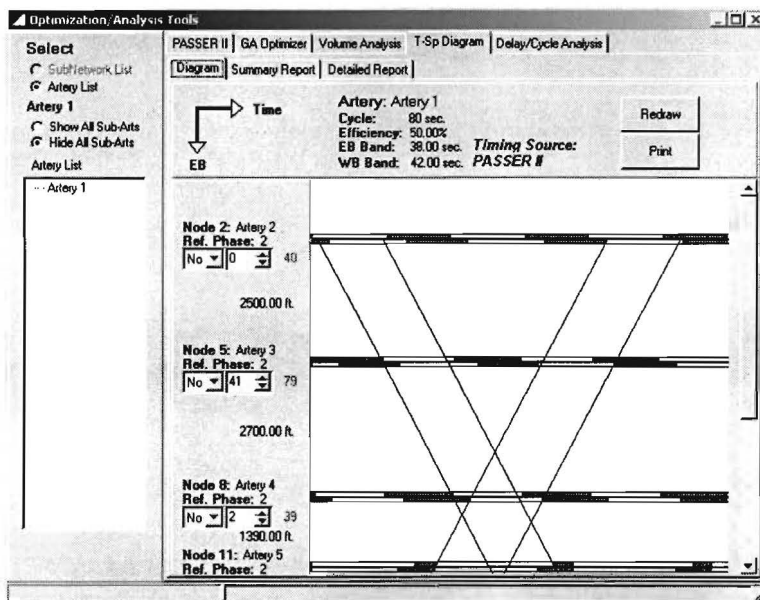

If you would rather use the GA Optimizer to produce a genetic algorithm derived solution for your arterial, click on the GA Optimizer tab. The GA Optimizer computes an optimal solution for delay or bandwidth (based on which you choose) by having “seed” or estimated solutions compete against one another to “filter” or “evolve” until a preferred solution emerges. Options for the GA Optimizer include specifying a cycle length range and increment and telling the optimizer whether or not you want to optimize phase sequence and offset for each intersection along the arterial (see below). Note that the reason the GA Optimizer gives you these options is that in certain situations, such as when analyzing an artery that includes a diamond interchange, you may want to optimize the diamond first, fix its signal settings, and then optimize the rest of the arterial around the diamond.

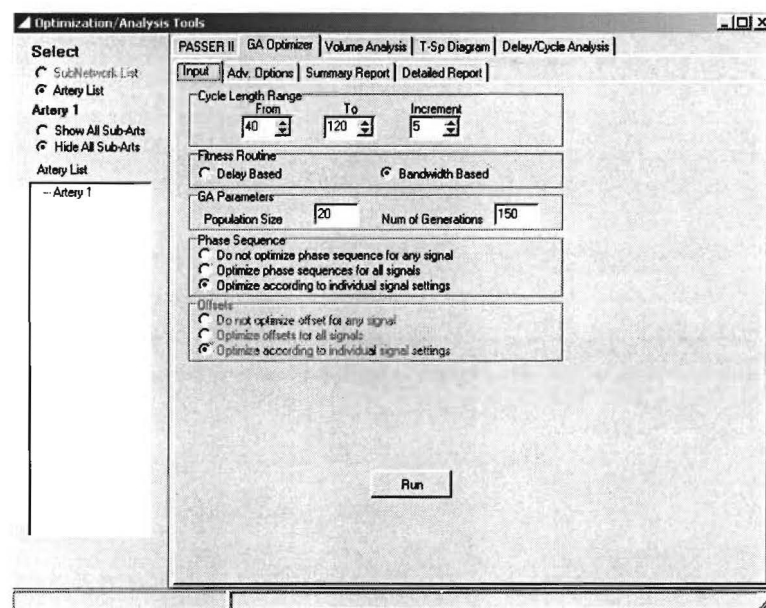

The GA Optimizer can be adjusted by changing the GA Parameters underneath the Input tab or by altering the settings for the optimizer beneath the Adv. Options tab. However, it is recommended that you do not adjust these settings unless the GA Optimizer is having difficulty deriving an optimal solution for the artery you are analyzing. If this is the case, first try increasing the Num of Generations setting under the Input tab. Note that it usually takes longer to run the GA Optimizer than it takes to run a PASSER II analysis. The progress bar along the bottom of the Tools dialog will give you an idea of how quickly the optimizer is running your analysis.

As with the PASSER II tool, the output for your analysis can be seen under the Summary Report and Detailed Report tabs. In this case, the GA Optimizer evolves to a single optimal solution, so only this solution’s summary statistics are viewable in the Summary Report. To view a time-space diagram of the GA Optimizer-based solution, click on the T-Sp Diagram tab and click on ‘Redraw.’ Note that PASSER II and GA Optimizer solutions to the same arterial analysis will be different, but will usually have similar splits and cycle lengths if a Bandwidth-Based Fitness Routine is used by the GA Optimizer.

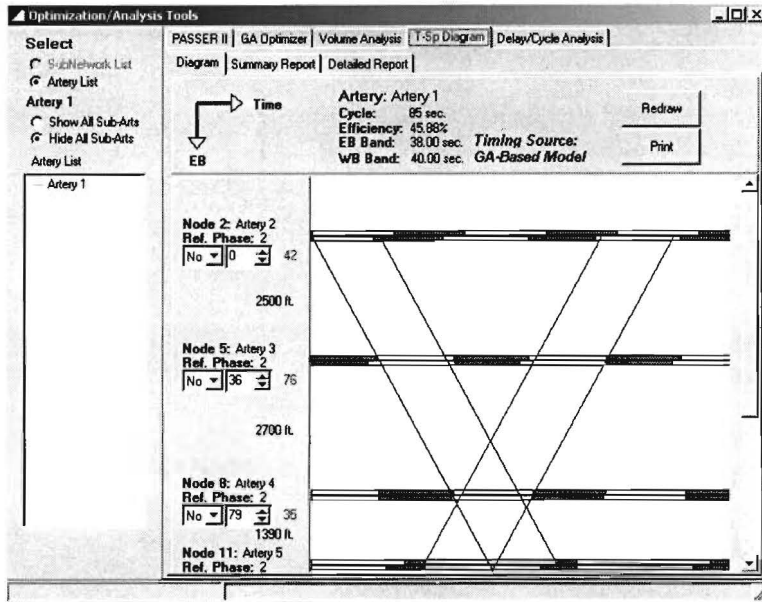

Note that if the artery you are currently analyzing contains a diamond interchange, you cannot use the PASSER II tool. Therefore, you must use the GA Optimizer tool to have PASSER V generate optimal timings. As stated earlier, you will usually optimize the interchange first (probably using the PASSER III tool), fix its signal settings, and then analyze the artery's remaining intersections using the GA Optimizer.

Additional tools available beyond the PASSER II and GA Optimizer tools for arterials include the Volume Analysis, T-Sp Diagram, and Delay/Cycle Analysis tools. The Volume Analysis tool (shown below) allows you to graph throughput for each cycle length you wish to analyze (you specify the range) and shows the current volume entered for the artery.

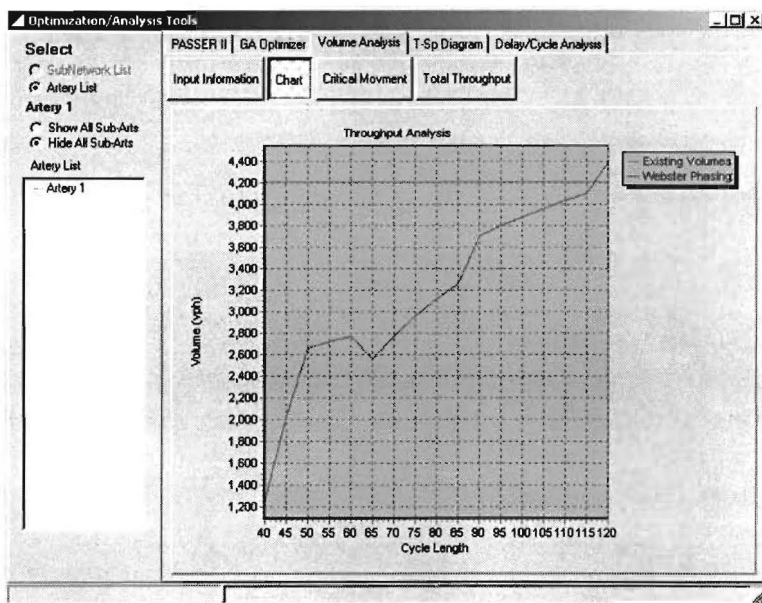



Note that the Volume Analysis tool does not incorporate the effects of progression between intersections. As a result, the junction of the Webster minimum delay/cycle length curve and the current volumes line indicates the cycle length necessary for the critical intersection in isolated mode.

The Volume Analysis tool's Critical Movement tab (see screenshot below) can be used to identify which intersection movement (and at which intersection) is critical at each cycle length within the cycle length range you specify. This information can potentially be used to help identify where geometric improvements (right- or left-turn bay improvements, etc.) might play a role in improving overall corridor mobility along the artery.

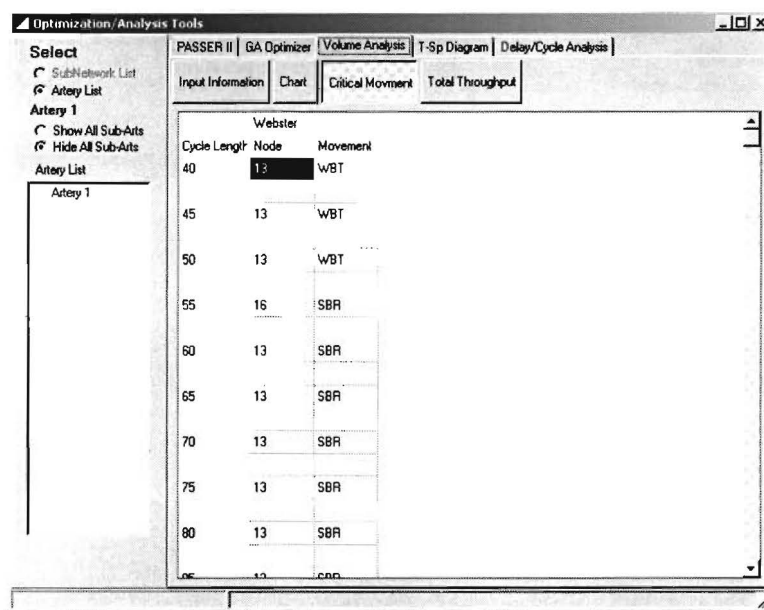

The T-Sp Diagram, or time-space diagram, tool within PASSER V is mentioned as an analysis tool because it can be used for purposes beyond showing the progression resulting from a PASSER II or GA Optimizer analysis. Offsets can be manually adjusted in the T-Sp Diagram tool so that you can see what affect different offsets at each intersection will have on your arterial roadway. In some instances, you may want to manually adjust a PASSER II or GA solution to create increasing bandwidth at successive downstream intersections, or you may want to ensure that at least some arterial green is available at each intersection to “clear out” the main approach before the arrival of the progression band. Once you have made the desired manual adjustments, clicking on ‘Redraw’ will show you the resulting progression. If you do opt to make manual offset adjustments, the T-Sp Diagram tool will indicate that the source of the currently displayed time-space diagram is manually adjusted settings (see next figure). If you wish to view the report of the current solution being displayed in the time-space diagram viewing window, click on the Summary or Detailed Reports tabs. Note that any manual adjustments to the time-space diagram will produce changes in the report’s summary statistics and in the MOEs and controller settings output for the manually adjusted intersections.

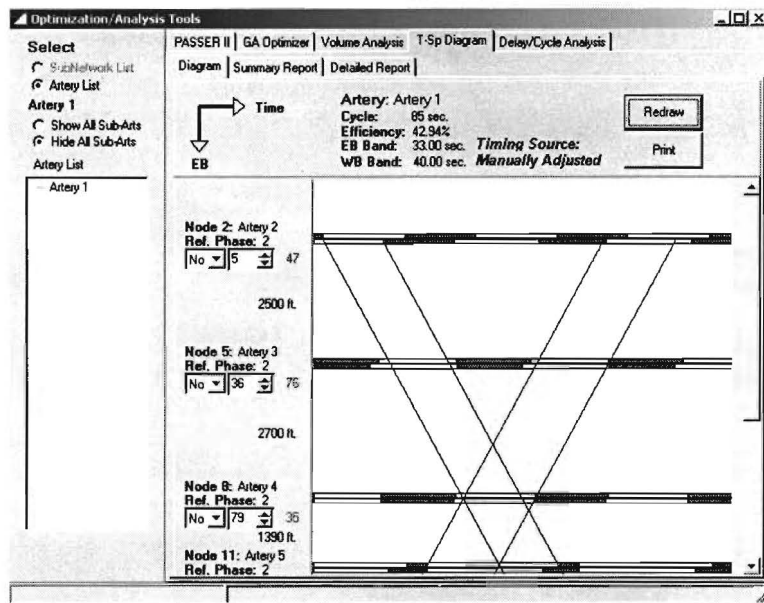

The final tool available for an artery is the Delay/Cycle Analysis. This tool creates a delay (y-axis) versus cycle length (x-axis) curve for your artery and provides information about the range of cycle lengths that are likely to provide you with optimal or near-optimal arterial operation. System-wide average vehicle delay is provided both from PASSER V and (for comparative purposes) from the *Highway Capacity Manual* [6]. The figure below is a screenshot of a delay versus cycle length curve from PASSER V. This tool is useful for analyzing the effects of cycle length variation on delay. Offsets can be kept fixed or adjusted proportionally to account for any cycle length changes you wish to analyze. Note that if you adjust cycle length, you may no longer have optimum offsets for the new cycle length.

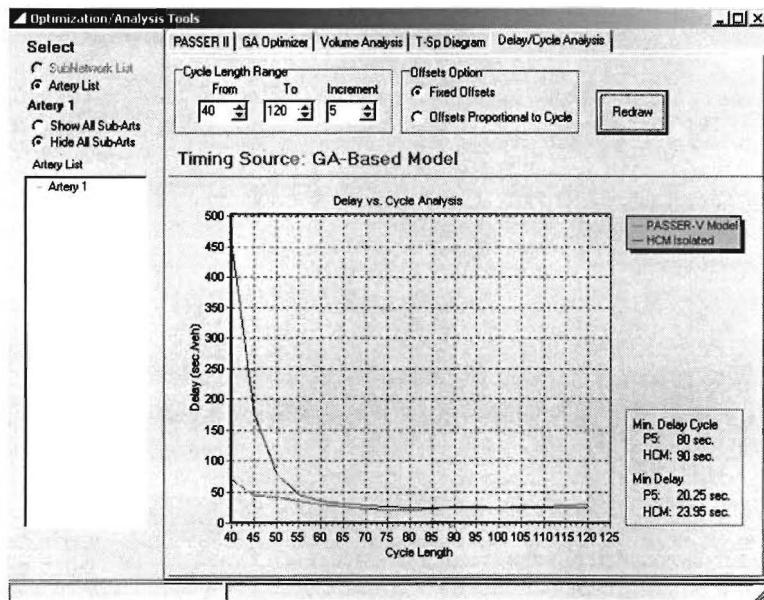

If your analysis includes a diamond interchange (which you specify by clicking on the link representing the interior of the interchange and checking the box at the bottom of the link edit dialog box for a diamond interchange), you also have access to the PASSER III optimization tool. PASSER III optimizes signal settings for the two intersections of the diamond using one of the three signal phasing schemes (Basic three-phase, Extended three-phase, or four-phase) used in Texas for these interchanges. Note that when a diamond interchange is specified along an artery, the PASSER II optimization tool is not available to optimize the overall artery; the GA Optimizer must be used. Also note that the PASSER III tool only appears in the tools list when the interchange (which exists as a subsystem along the artery) is selected as a subsystem. When using the PASSER III tool (see image below), you specify the cycle length range and increment for your analysis as well as the type of diamond interchange phasing you want (in any combination). If multiple phasing options are selected, PASSER III will determine which one produces the least delay for each cycle length analyzed.

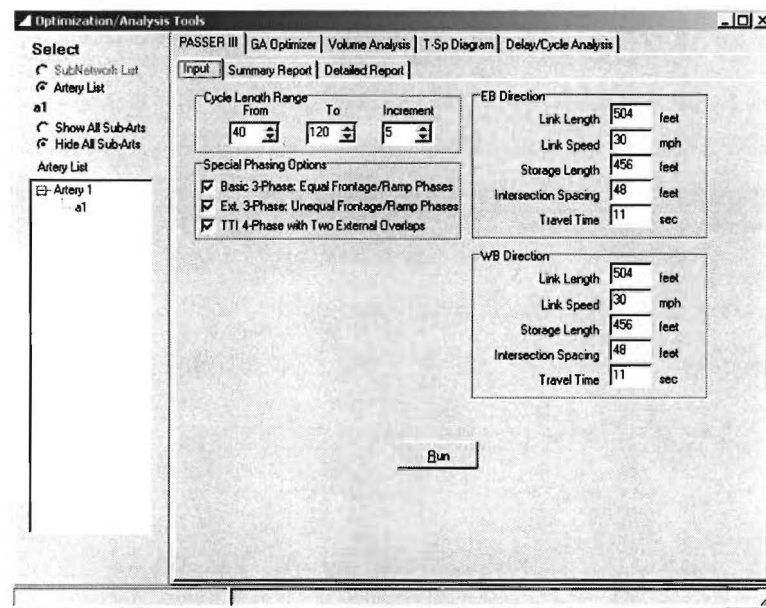

As with the PASSER II tool, PASSER III produces both a summary report and a detailed report. The summary report gives interchange-level details (delay, phasing sequence/type for each cycle length analyzed, stops, presence of spillback, etc.) while the detailed report gives movement-specific MOEs and signal settings for the combination of cycle length and phasing type you select from the pull-down boxes at the top of the window.

When you analyze any subsystem, including a diamond interchange, note that you still have access to most of the analysis tools available from PASSER V. Diamond interchanges, like other subsystems of signals along the arterial, can be analyzed using the GA Optimizer. In this case, the GA Optimizer picks what it believes is the optimal diamond phasing sequence and cycle length for the interchange. This sequence (and cycle length) may be different than the optimal solution identified by PASSER III. Regardless of the source of the diamond solution, its arterial progression bands can be seen in T-Sp Diagram (see next figure). The

Volume Analysis and Delay/Cycle Analysis tools remain at your disposal as well. If you select the Volume Analysis Tool for an interchange, you will get a throughput analysis for each diamond interchange phasing type you specify (see second figure below).

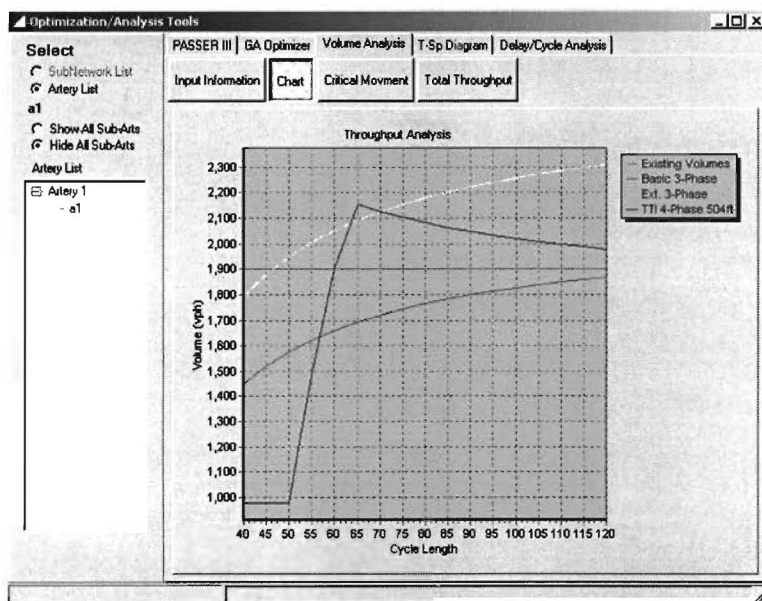
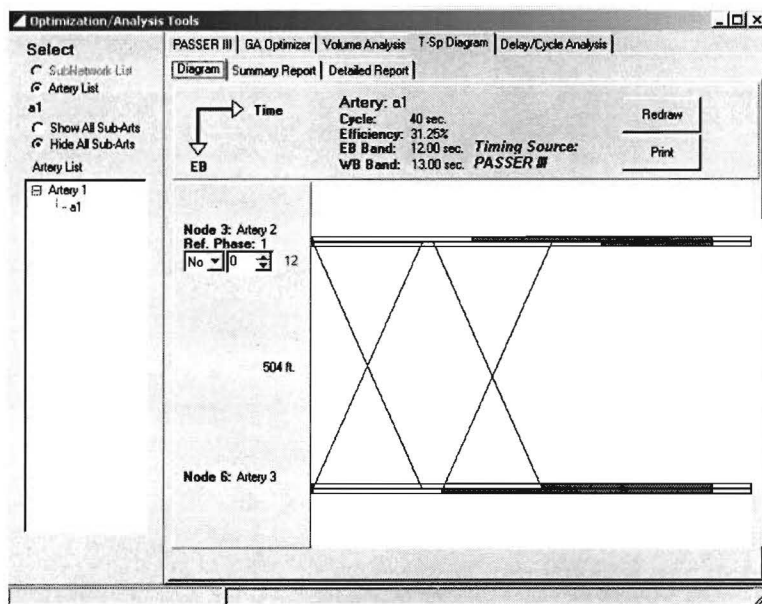



## Isolated Intersection Analysis

*Using PASSER V to analyze an individual, or isolated, intersection.*

The most simple type of optimization analysis you can perform using the tools available in PASSER V is for an isolated intersection. But, before you start PASSER V, make sure that you have all of the input data you need (geometric details, traffic volume data, and signal settings) well organized and within reach.

When you are ready to start PASSER V, double-click on the program icon (if you created one) or click on Start from the Windows taskbar, select Programs, Passer V-03 folder, and the PASSER V-03 program. Start a new analysis file/project by clicking on File|New from the file menu bar or by clicking on the “blank sheet” icon on the PASSER V file access toolbar. Then, click on the System icon from the PASSER V function toolbar and enter your project, agency, and analyst name information. Activate the background grid by selecting View from the file menu bar and clicking on ‘Show Grid.’

### Geometry Data Entry

You actually begin using PASSER V when you draw links in the main PASSER V editing window. In this case, you will draw an east-west roadway (two way) about 2000 ft long (PASSER V displays the length of the link you are actively creating in the lower left corner of your screen, next to the axis coordinate display), and then draw a north-south roadway (two way, also 2000 ft long) that intersects the east-west roadway near the center of both roadways. When you are finished, your screen will look like the figure on the next page. Notice from your computer screen that PASSER V automatically numbers the nodes of the network as you create them, and that the intersection between the two roadways you drew has been automatically created as a signalized intersection along both arteries. The circle, or node, representing this intersection is red in color to indicate that input data entry for the node (i.e., geometric details, turning movements, and signal setting information) has either not been started or is not yet complete.

Since our current analysis is for an isolated intersection, we are finished “creating” links and nodes for the network. Next, we focus on the internal, signalized intersection node and the types of information we need to enter for this node. Click on the Control button from the PASSER V function toolbar and then click on the internal node.

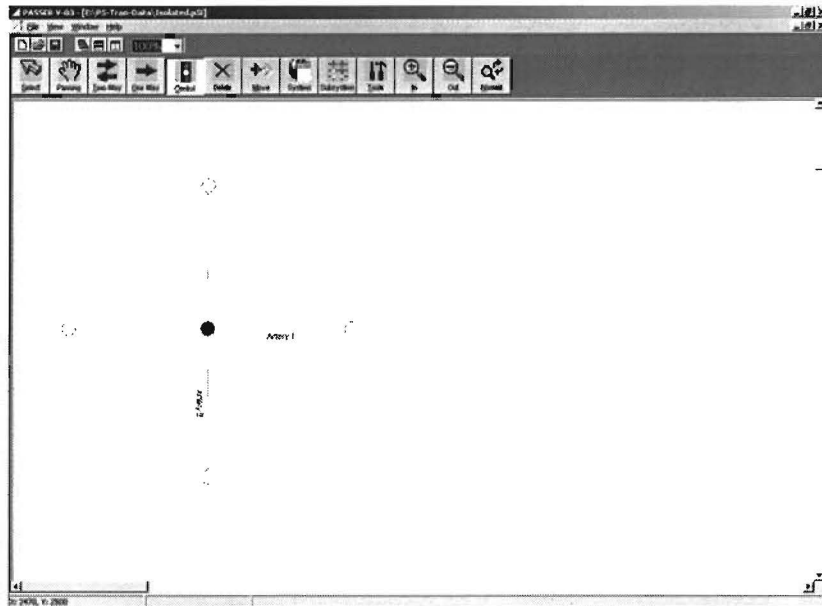

A Node Data dialog box with data entry tabs will appear for the node (see figure below), and you will use the tabs within this dialog to enter your input data and get your isolated intersection signal settings from PASSER V. The example problem we will use for this analysis is the intersection of S.W. Military Drive and South Presa in San Antonio, Texas. An intersection plan view on the next page shows all available facts at our disposal concerning the signalized intersection. We will be coding volumes for the PM peak hour.

Data Access Tabs

The Node Data dialog box is shown with the following fields and tabs:

- Controller Id: 3
- Nodes In Controller: Node 3
- Controller Type: NEMA 2
- Cycle Length: 90
- Area Type: Other
- Nodes: Node 3
- Signal Type: Pretimed Signal
- Offset Ref: [Dropdown]
- Offset: 0

Available tabs: Timing Data, Sat. Flow Data, Optimization Data, Delay vs. Cycle Analysis, Controller, Signal MOEs.

Movement	EBL	EBT	EBR	WBL	WBT	WBR	SBL	SBT	SBR	NBL	NBT	NBR
Lane Assignment	0	0	0	0	0	0	0	0	0	0	0	0
Volume (vph)	100	100	100	100	100	100	100	100	100	100	100	100
Movement Type												
Left-turn Phasing												
Overlap?												
Minimum Green (sec)												
Yellow (sec)												
Red Clearance (sec)												
Lost Time (sec)												
Green Spills (%)												
Green Spills (sec)												

Optimization Settings:

- Lock Sat Flows
- Lock Green Spills

Buttons: Update, OK, Cancel

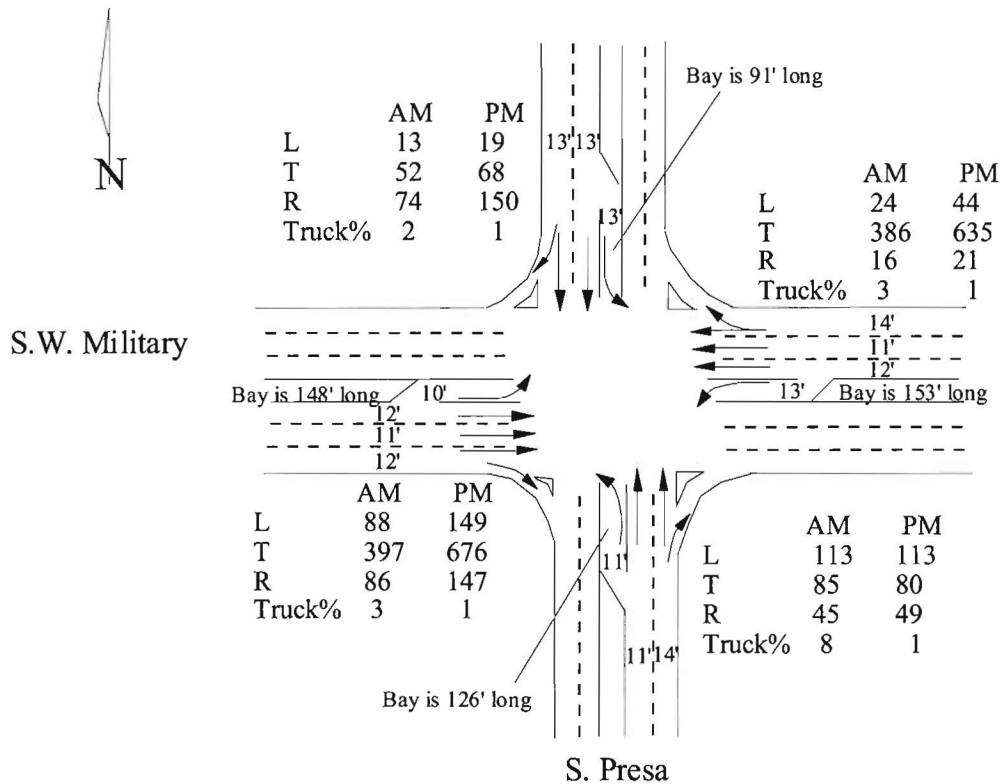

Note that though the data shown are adequate for purposes of generating output using PASSER V (i.e., it shows volumes, number of lanes, lane usage, lane widths), it is incomplete in meeting all requirements for a complete signalized intersection analysis. Additional data that would make it possible to do a thorough analysis include shoulder presence and width (if any), pedestrian signal locations, presence and location of pedestrian push buttons, signal displays for each approach and left-turn bay, driveway locations close to the intersection, etc. It is essential that thorough data are at your disposal when conducting any signalized intersection analysis – the quality of your intersection recommendations is dependent on your ability to incorporate all pertinent factors affecting intersection safety and operation.

To begin your input data entry, review the fields at the top of the Timing Data tab/folder within the Node Data dialog box. Note that this intersection is not located within the CBD (central business district, or downtown area) of San Antonio. Also note that because this is an isolated intersection analysis, we do not need to worry about NEMA 2 phase direction, offset reference direction, or offset value information for coordination.

Begin your data entry by clicking in the Lane Assignment field for the eastbound movement. A new window appears, prompting you for information about all of the lanes of the eastbound approach to the intersection. In this case, there are a total of four lanes. The leftmost lane is a left-turn bay, the middle two lanes are for through movements only (selectable by clicking in the check boxes beneath the lane), and the right lane is for through and right-turn movements. Make sure to enter in the 148-foot length for the left-turn bay



and the appropriate lane widths for each lane. Note also that we are assuming level grade for this approach, no bus stops in the peak hour, and no on-street parking maneuvers. When you are finished with geometric data entry for the eastbound approach, your approach entry window should look like the one below.

	Lane1	Lane2	Lane3	Lane4
L	<input checked="" type="checkbox"/>	<input type="checkbox"/>	<input type="checkbox"/>	<input type="checkbox"/>
T	<input type="checkbox"/>	<input checked="" type="checkbox"/>	<input checked="" type="checkbox"/>	<input checked="" type="checkbox"/>
R	<input type="checkbox"/>	<input type="checkbox"/>	<input type="checkbox"/>	<input checked="" type="checkbox"/>
Lane Width (ft)	10.00	12.00	11.00	12.00
Bay?	Yes	No	No	No
Length (ft)	148	927	927	927
Bus Stops (#/hr)				0
Adjacent Parking				No
Parkings (#/hr)				0

It is important to note at this point that there is a relationship between the right-turning geometry you enter into PASSER V and the volume you will enter later for the right-turning movement. Essentially, we want to have our analysis account for right turning on red vehicles, and ensure that we enter only the right-turning volume in PASSER V that actually uses a portion of the approach phase time. For each of the possible right-turn geometries shown in the chart on the next page, guidance is given to help you determine what right-turning volume to enter in PASSER V. In some cases, especially where a full right-turn bay or lane is present, you should not enter any right-turn volume into PASSER at all, and code the approach such that no right-turn movement exists. In other words, if all right-turning vehicles are handled by their own lane or as right turns on red (i.e., they do not use signal green time to get through the intersection), code PASSER V so that there is no right-turn movement for that approach. Note that this rule of thumb is for isolated intersections only; in cases where right-turn bays or channels exist along a coordinated arterial, you will want to enter at least some right-turning volume so that the flow, or “profile,” of right-turning traffic reaches the next intersection in your network (for proper delay calculations).

Repeat this procedure for each of the other three approaches to the intersection, entering in the correct number of lanes, appropriate lane movements, lane widths, and left-turn bay presence and length. When you have finished with this approach data entry step, your Node Data dialog box/window should look like the screenshot on the next page.

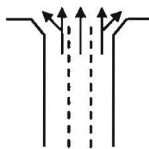
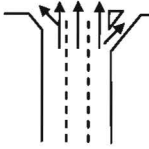
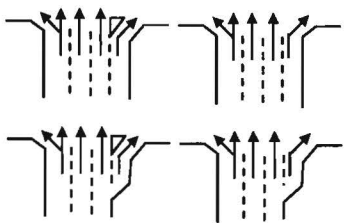
Right Turn Geometry	Queuing Condition	
	Queue Does Not Block Access to Channel or Bay	Queue Blocks Access to Channel or Bay
<p>No Right-Turn Channel or Bay</p> 	<p>Full right-turn hourly volume, less the number of right turn on red vehicles per hour</p>	
<p>Right-Turn Channelized Island</p>  <p>or</p> <p>Right-Turn Bay/Lane</p> 	<p>Zero, unless right-turn volume is so high that right-turn volume cannot be cleared as right turn on red. If this is the case, enter unserved right turn on red volume in vehicles per hour. If the right-turn volume is zero according to this rule, do not code a right-turn movement for this approach.</p>	<p>Enter number of right-turning vehicles per hour that are blocked from the right-turn channel by the queue.</p>

Node Data

Controller Id: 3    Nodes In Controller: Node 3    Controller Type: NEMA 2    Cycle Length: 90

Area Type: Other    Predefined Signal    Offset: 0

Movement	EBL	EBT	EBR	wBL	wBT	wBR	SBL	SBT	SBR	NBL	NBT	NBR
Lane Assignment	3	1	1	3	0	0	1	2	1	1	2	0
Volume (vph)	100	100	100	100	100	0	100	100	100	100	100	0
Movement Type	Prot	Prot	Prot	Prot	Prot		Prot	Prot	Prot	Prot	Prot	
Left-turn Phasing	Lead			Lead			Lead			Lead		
Overlap?		Yes			Yes			Yes			Yes	
Minimum Green (sec)	6	6	6	6	6		6	6	6	6	6	
Yellow (sec)	3	3	3	3	3		3	3	3	3	3	
Red Clearance (sec)	1	1	1	1	1		1	1	1	1	1	
Lost Time (sec)	4	4	4	4	4		4	4	4	4	4	
Green Splits (%)	0	0	0	0	0		0	0	0	0	0	
Green Splits (sec)	0	0	0	0	0		0	0	0	0	0	

Optimization Settings

Lock Sat Flows

Lock Green Splits

Update    OK    Cancel

## Volume Data Entry

Our next step is to enter the volumes (in vehicles per hour, or vph) for each approach's turning movements. Note that the volumes you enter here do not need to be adjusted for peak hour factor (see Chapter 2) effects; we will enter peak hour factors for each movement later in the data entry process. Since we are using the PM peak volumes, enter the volumes 149, 676, and 147 for the left, through, and right volume fields, respectively, for the eastbound approach. Then, enter the volumes for the movements on the other three approaches. When you are finished, your Node Data window should look like this:

Movement	EBL	EBT	EBR	WBL	WBT	WBR	SBL	SBT	SBR	NBL	NBT	NBR
Lane Assignment	1	3	1	1	3	0	1	2	1	1	2	0
Volume (vph)	149	676	147	44	636	0	19	58	150	113	80	0
Movement Type	Prot	Prot	Prot	Prot	Prot		Prot	Prot	Prot	Prot	Prot	
Left-turn Phasing	Lead			Lead			Lead			Lead		
Overlap?		Yes			Yes			Yes			Yes	
Minimum Green (sec)	6	6	6	6	6		6	6	6	6	6	
Yellow (sec)	3	3	3	3	3		3	3	3	3	3	
Red Clearance (sec)	1	1	1	1	1		1	1	1	1	1	
Lost Time (sec)	4	4	4	4	4		4	4	4	4	4	
Green Splits (%)	0	0	0	0	0		0	0	0	0	0	
Green Splits (sec)	0	0	0	0	0		0	0	0	0	0	

Optimization Settings:  
 Lock Sat Flows  
 Lock Green Splits

Update    OK    Cancel

Our next task is to select the appropriate Movement Type for each of our left-turn movements. To review the available options, click in the Movement Type field for the eastbound left (EBL). A pull-down box with the options shown below will appear.

Timing Data	Sat. Flow Data	Optimization Data	Delay
Movement	EBL	EBT	EBR
Lane Assignment	1	3	1
Volume (vph)	149	676	97
Movement Type	Prot	Prot	Prot
Left-turn Phasing	Ferm		
Overlap?	Prot+Perm Split	Yes	
Minimum Green (sec)	0	6	6
Yellow (sec)	3	3	3
Red Clearance (sec)	1	1	1
Lost Time (sec)	4	4	4
Green Splits (%)	0	0	0
Green Splits (sec)	0	0	0

The available left-turning movement types having the following meanings:

- **Perm.** Permitted left turns under a “green ball” indication; left turners must find acceptable gaps in the opposing traffic stream before making their maneuver.
- **Prot.** Protected, or exclusive, left-turn movement under a “green arrow” indication. Left-turning vehicles have right of way to make their maneuver.
- **Prot+Perm.** Combination of permitted and protected left turns; a portion of this approach’s left-turn time is under a protected green arrow and a portion is available for permitted maneuvers. If lagging protected left-turn phases are used, be aware of the possibility of a “yellow trap” (see Chapter 1) emerging.
- **Split.** “Split Phased” operation, wherein the left and through movements for an approach are programmed into the controller to begin and end simultaneously. Usually used for minor street approaches where left-turn paths from opposing directions overlap.

For our example isolated intersection, the eastbound and westbound approach’s left-turning vehicles have to cross three opposing lanes of traffic. As it is usual engineering practice to only allow permitted left turns across no more than two opposing lanes, the eastbound and westbound approaches are protected only. Click in the data entry field for each of these movements and select ‘Prot.’ Our northbound and southbound approach’s left turners only face two opposing through lanes (and we have no other data to indicate that permitted left turns should not be allowed), so select ‘Prot+Perm’ for these approaches.

In general, it may be necessary to reduce the amount of right-turning volume you enter into PASSER V due to right turns on red, the presence of a right-turn channelized island, and/or a right-turn bay. If there is a right-turn channelized island or bay, it does not necessarily mean that the right-turn volume should not be included in PASSER V. If a queue for the through movement on the approach blocks access to the right-turn channel or bay, then the amount of right-turning traffic (number of vehicles per hour) blocked by the queue should be entered into PASSER V as right-turning volume.

Reduce the right-turning vehicles per hour (vph) to zero volume due to right turn on red for the northbound and westbound approaches. The low right-turning and through volume on the northbound approach means that there will be ample opportunity for all right turners to clear on red. The very low right-turning volume on the westbound approach can easily be served as RTOR, even though the through volume is relatively high (you would have to observe any intersection you study to verify the number of possible right turns on red).

However, on the southbound approach the right-turn volume was sufficiently high (even though the through volume was low) that we did not feel that all vehicles could make RTOR, so we reduced the 150 vph turning right by an estimated 75 RTOR to come up with 75 vph for the right turn that we entered into PASSER V. Finally, on the eastbound approach both the through and right volume were high. Therefore, we only reduced the

147 vph right-turn volume by an estimated 50 RTOR, and entered 97 vph as right-turn volume in PASSER V. When your adjustments to right-turn volume are complete, your screen should look like the one below.

Movement	EBL	EBT	EBR	WBL	WBT	WBR	SBL	SBT	SBR	NBL	NBT	NBR
Lane Assignment	1	3	1	1	3	0	1	2	1	1	2	0
Volume (vph)	149	676	97	44	635	0	19	68	75	113	80	0
Movement Type	Prot	Prot	Prot	Prot	Prot		Prot+Per	Prot	Prot	Prot+Per	Prot	
Left-turn Phasing	Lead			Lead			Lead			Lead		
Overlap?		Yes			Yes			Yes			Yes	
Minimum Green (sec)	6	6	6	6	6		6	6	6	6	6	
Yellow (sec)	3	3	3	3	3		3	3	3	3	3	
Red Clearance (sec)	1	1	1	1	1		1	1	1	1	1	
Lost Time (sec)	4	4	4	4	4		4	4	4	4	4	
Green Splits (%)	0	0	0	0	0		0	0	0	0	0	
Green Splits (sec)	0	0	0	0	0		0	0	0	0	0	

Optimization Settings  
 Lock Sat Flows   
 Lock Green Splits

Update OK Cancel

## Signal Settings Data Entry

We will now focus our attention on the signal settings/parameters that we must enter into PASSER V. The first selection we must make is whether each left-turn phase leads (precedes in the signal sequence) the opposing through phase. Since this is an isolated intersection (i.e., coordination needs do not lead us to prefer one phasing sequence over another), we will pick “Lead” for all of our approaches. Leading left turns are the “default” left-turn treatment due to their location in NEMA dual-ring operation, and leading left turns have the added advantage of avoiding the “yellow trap” issue for our southbound and northbound protected+permitted left turns.

The next phasing option is whether or not to allow each approach’s through movement to “Overlap,” or run simultaneously with the through movement from that same approach. If you do allow overlap, the lower volume left-turn phase on a given roadway will terminate early, allowing the opposing through to begin early. This allows the through phase/movement to run for some time with its left turn before that left-turn phase ends or reaches its maximum, at which time the other through phase/movement will begin (in leading left-turn situations). If Overlap is not allowed, the leading left turns will begin and end together before the through phases/movements begin. Generally speaking, allowing Overlap operation is more efficient than not allowing the overlap to occur. At our

intersection, allow the Overlap by selecting 'Yes' (the default) for all four approaches. At this point, your Node Data screen/window should look like the figure below.

Movement	EBL	EBT	EBR	WBL	WBT	WBR	SBL	SBT	SBR	NBL	NBT	NBR
Lane Assignment	1	3	1	1	3	0	1	2	1	1	2	0
Volume (vph)	149	675	97	44	635	0	19	68	75	113	80	0
Movement Type	Prot	Prot	Prot	Prot	Prot		Prot+Per	Prot	Prot	Prot+Per	Prot	
Left Turn Phasing	Lead			Lead			Lead			Lead		
Overlap?		Yes			Yes			Yes			Yes	
Minimum Green (sec)	6	6	6	6	6		6	6	6	6	6	
Yellow (sec)	3	3	3	3	3		3	3	3	3	3	
Red Clearance (sec)	1	1	1	1	1		1	1	1	1	1	
Lost Time (sec)	4	4	4	4	4		4	4	4	4	4	
Green Spills (%)	0	0	0	0	0		0	0	0	0	0	
Green Spills (sec)	0	0	0	0	0		0	0	0	0	0	

Minimum green times in PASSER V are either the minimum green time you would enter into a controller for vehicular phasing (based on driver requirements, setback detector location, etc.) or, where there are no pedestrian buttons, the combination of the pedestrian walk and clearance times. If there are no pedestrian buttons (which would activate pre-programmed pedestrian phases with their own minimum "WALK" and flashing "DON'T WALK" clearance times), the sum of the pedestrian walk and clearance times will likely be greater than the vehicular minimum green time and should be entered. In other words, if the intersection does not include pedestrian buttons, you need to ensure the minimum phase times you enter into PASSER V are adequate for pedestrians as well as vehicles.

We will assume there are **no** pedestrian buttons at our intersection, and we will compute pedestrian minimum phase time as 7 seconds of walk plus the result of roadway width divided by an average walking speed of 4 feet per second. For the northbound through phase, this equation results in a minimum pedestrian phase time of  $7 + (12+11+12+13+12+11+14)/4 = 28.25$ , or 29 seconds. After computing and entering the minimum pedestrian phase times for all approaches, your screen should resemble those in the next screenshot. Note that the MUTCD [1] indicates that a pedestrian walk signal should be active for 7 seconds unless conflicting phases need added green time; in such situations, 4 seconds can be used as the pedestrian walk time.

Another consideration that affects the entered minimum green time is whether or not your agency allows you to simultaneously clear the vehicular and pedestrian portions of a phase (i.e., simultaneous vehicular yellow ball indication and pedestrian flashing "DON'T WALK"). If your agency allows this (note: the MUTCD [1] does not prohibit you from

allowing it), then subtract the phase's yellow change interval time from the minimum green time and enter the result into PASSER V. Remember to check the minimum green time after subtracting the yellow change interval time from the minimum green time (for pedestrian requirements) to ensure that the sum of the pedestrian walk and clearance times, less the yellow change interval, remains greater than the minimum green for vehicular requirements.

Movement	EBL	EBT	EBR	WBL	WBT	WBR	SBL	SBT	SBR	NBL	NBT	NBR
Lane Assignment	1	3	1	1	3	0	1	2	1	1	2	0
Volume (vph)	149	676	97	44	635	0	19	68	75	113	80	0
Movement Type	Prot	Prot	Prot	Prot	Prot		Prot+Per	Prot	Prot	Prot+Per	Prot	
Left-turn Phasing	Lead			Lead			Lead			Lead		
Overlap?		Yes			Yes			Yes			Yes	
Minimum Green (sec)	6	19	6	6	19		6	24	6	6	24	
Yellow (sec)	3	3	3	3	3		3	3	3	3	3	
Red Clearance (sec)	1	1	1	1	1		1	1	1	1	1	
Lost Time (sec)	4	4	4	4	4		4	4	4	4	4	
Green Splits (%)	0	0	0	0	0		0	0	0	0	0	
Green Splits (sec)	0	0	0	0	0		0	0	0	0	0	

Optimization Settings  
 Lock Sat Flows   
 Lock Green Splits

Update OK Cancel

The last elements of data entry necessary for an isolated intersection are the Yellow (change interval) and Red Clearance interval times. Recall from Chapter 1 that yellow change and all red clearance times are dependent on the speed and grade on each approach and on the intersection's width in that approach's direction of flow. Assuming a speed of 45 mph on S.W. Military (our east-west street) and 35 mph on S. Presa (our north-south street), we come up with yellow change and red clearance times of 4.31 and 1.35 seconds (see tables in Chapter 1) for S.W. Military and 3.57 and 2.14 seconds on S. Presa. Since PASSER V cannot accept non-integer inputs for the phase times, we will interpret the change and clearance intervals as 5 seconds of yellow change plus 1 second of red clearance for S.W. Military and 4 seconds of yellow change plus 2 seconds of red clearance for S. Presa. Note that though we changed the allocation of time between the yellow change interval and red clearance interval slightly for each roadway, we made sure that the sum of the two for each roadway was at least as large as the sum called for by the tables in Chapter 1. When you are finished, your Node Data window should look like the screenshot on the next page.

Node Data

Controller Id: 3    Nodes In Controller: Node 3    Controller Type: NEMA 2    Cycle Length: 90

Area Type: Other    Pretimed Signal    Offset Ref:    Offset: 0

Timing Data    Sat. Flow Data    Optimization Data    Delay vs. Cycle Analysis    Controller    Signal MOEs

Movement	EBL	EBT	EBR	WBL	WBT	WBR	SBL	SBT	SBR	NBL	NBT	NBR
Lane Assignment	1	3	1	1	3	0	1	2	1	1	2	0
Volume (vph)	149	676	97	44	635	0	19	68	75	113	80	0
Movement Type	Prot	Prot	Prot	Prot	Prot		Prot+Perm	Prot	Prot	Prot+Perm	Prot	
Left-turn Phasing	Lead			Lead			Lead			Lead		
Overlap?		Yes			Yes			Yes			Yes	
Minimum Green (sec)	6	19	6	6	19		6	24	6	6	24	
Yellow (sec)	5	5	5	5	5		4	4	4	4	4	
Red Clearance (sec)	1	1	1	1	1		2	2	2	2	2	
Lost Time (sec)	4	4	4	4	4		4	4	4	4	4	
Green Splits (%)	0	0	0	0	0		0	0	0	0	0	
Green Splits (sec)	0	0	0	0	0		0	0	0	0	0	

Optimization Settings

Lock Sat Flows

Lock Green Splits

Update    OK    Cancel

The final detail we need to check under the Timing Data tab is the Lost Time entry in seconds for each phase. Lost time represents the loss in signal efficiency that results from (hopefully) no vehicles moving through the intersection at the end of a phase (say, during the red clearance interval) and the fact that no vehicles are moving through the intersection when any approach first receives a green signal indication (i.e., it takes motorists a few seconds to react to a green indication, take their foot off of the brake, and begin accelerating). As 4 seconds is a good estimate of lost time, we will leave this (default) value in place.

The next step is to advance to the Sat. Flow Data tab (i.e., the next tab) within the Node Data window. A screenshot of this tab/folder is shown below. The items we will need to check and/or modify here include the peak hour factor, the growth factor, the ideal saturation flow rate, and the truck (heavy vehicle) percentage.

Node Data

Controller Id: 3    Nodes In Controller: Node 3    Controller Type: NEMA 2    Cycle Length: 90

Area Type: Other    Pretimed Signal    Offset Ref:    Offset: 0

Timing Data    Sat. Flow Data    Optimization Data    Delay vs. Cycle Analysis    Controller    Signal MOEs

Movement	EBL	EBT	EBR	WBL	WBT	WBR	SBL	SBT	SBR	NBL	NBT	NBR
Lane Assignment	1	3	1	1	3	0	1	2	1	1	2	0
Volume (vph)	149	676	97	44	635	0	19	68	75	113	80	0
Adjusted Flow (vph)	100	100	100	100	100	0	100	100	100	100	100	0
Peak Hour Factor	1.00	1.00	1.00	1.00	1.00		1.00	1.00	1.00	1.00	1.00	
Growth Factor	1.00	1.00	1.00	1.00	1.00		1.00	1.00	1.00	1.00	1.00	
Heavy Vehicles (%)	2.00	2.00	2.00	2.00	2.00		2.00	2.00	2.00	2.00	2.00	
Ideal Sat Flow (pcphg)	1900	1900	1900	1900	1900		1900	1900	1900	1900	1900	
SatFlow (pcphg)	1900	1900	1900	1900	1900		1900	1900	1900	1900	1900	
Prot SatFlow (pcphg)	1900	1900	1900	1900	1900		1900	1900	1900	1900	1900	
Perm SatFlow (pcphg)	1400			1400			1400			1400		

Update    OK    Cancel



First, we will examine the peak hour factor (PHF). Note from our discussions in Chapter 2 that PHF is a ratio of the total hourly volume (or flow rate) to the hourly flow rate within the peak 15 minutes of the peak hour. If this ratio is less than 0.85, then volumes within the peak hour fluctuate significantly enough that you definitely need to incorporate the PHF into your analysis. By entering the PHF, you essentially “bump up” the hourly flow rate to account for heavy volume during the peak 15-minute period within the peak hour. For our example problem, we do not have PHF information (i.e., we have hourly counts and would need 15-minute counts to compute the PHF), so enter 0.90 so that at least some variability is accounted for in your analysis.

The next item to check is the growth factor. This is a convenient way for you to examine the affects of future growth on your signal and intersection. Entering a factor of 1.20 means that intersection volumes have “grown” by 20 percent. Since our volumes are current and we are developing timings for present operations, we will leave this value as 1.00.

The next setting that we can change for each movement is the default, or ideal, saturation flow rate. Since 1900 pcphgpl is the currently adopted value for the industry [6], you will only want to change the ideal value if some local factor (sight distance problems, usual curb radius, etc.) that we have not already included on our analysis affects traffic in such a way as to reduce the speed and flow rate at which motorists are willing to drive.

Finally, we need to enter the heavy vehicle, or truck, percentage for each of our approaches. From our diagram/plan view of the intersection, our truck percentages are 1 percent for each approach. Once you have entered this value for all movements, you have finished data entry for this isolated intersection and your screen will look like the screenshot below.

Movement	EBL	EBT	EBR	WBL	WBT	WBR	SBL	SBT	SBR	NBL	NBT	NBR
Lane Assignment	1	3	1	1	3	0	1	2	1	1	2	0
Volume (vph)	149	676	97	44	635	0	19	68	75	113	80	0
Adjusted Flow (vph)	100	100	100	100	100	0	100	100	100	100	100	0
Peak Hour Factor	.9	.9	.9	.9	.9		.9	.9	.9	.9	.9	
Growth Factor	1.00	1.00	1.00	1.00	1.00		1.00	1.00	1.00	1.00	1.00	
Heavy Vehicles (%)	1	1	1	1	1		1	1	1	1	1	
Ideal Sat Flow (pcphgpl)	1900	1900	1900	1900	1900		1900	1900	1900	1900	1900	
SatFlow (pcphg)	1900	1900	1900	1900	1900		1900	1900	1900	1900	1900	
Prot SatFlow (pcphg)	1900	1900	1900	1900	1900		1900	1900	1900	1900	1900	
Perm SatFlow (pcphg)	1400			1400			1400			1400		

Click on the Update button at the bottom of the Node Data window and the saturation flow rates will be adjusted to account for the change in the truck percentage. Then, go back to the Timing Data tab/folder and look at the green splits that PASSER V calculated for the intersection (see screenshot below). These are the optimal splits for a 90-second cycle!

Node Data

Controller Id: 3    Nodes In Controller: Node 3    Controller Type: NEMA 2    EBT EBR    Cycle Length: 90  
 Area Type: Other    Pretimed Signal    Offset Ref: EBT EBR    Offset: 0

Movement	EBL	EBT	EBR	WBL	WBT	WBR	SBL	SBT	SBR	NBL	NBT	NBR
Lane Assignment	3	1	1	3	0	0	1	2	1	1	2	0
Volume (vph)	149	676	97	44	635	0	19	68	75	113	80	0
Movement Type	Prot	Prot	Prot	Prot	Prot		Prot+Per	Prot	Prot	Prot+Per	Prot	
Left-turn Phasing	Lead			Lead			Lead			Lead		
Overlap?		Yes			Yes			Yes			Yes	
Minimum Green (sec)	6	19	6	6	19		6	24	6	6	24	
Yellow (sec)	5	5	5	5	5		4	4	4	4	4	
Red Clearance (sec)	1	1	1	1	1		2	2	2	2	2	
Lost Time (sec)	4	4	4	4	4		4	4	4	4	4	
Green Splits (%)	24.44	40.00	40.00	13.33	28.89		13.33	33.33	33.33	13.33	33.33	
Green Splits (sec)	22	36	36	12	26		12	30	30	12	30	

Optimization Settings:  
 Lock Sat Flows:   
 Lock Green Splits:

Update    OK    Cancel

Now, we want to go to the Delay vs. Cycle Analysis tab/folder to see if a 90-second cycle is really the optimal (i.e., least delay) cycle length for the PM peak at this intersection. You will see a graph just like the one below. Notice that minimum delay actually occurs around an 85-second cycle length rather than 90 seconds.

Node Data

Controller Id: 3    Nodes In Controller: Node 3    Controller Type: NEMA 2    EBT EBR    Cycle Length: 90  
 Area Type: Other    Pretimed Signal    Offset Ref: EBT EBR    Offset: 0

Cycle Length Range:  
 From: 40    To: 120    Increment: 5

Coded Cycle Length:  
 Cycle Length: 90 sec.  
 Delay (HCM): 30.63 sec/veh

Cycle Length Range Analysis:  
 Min. Delay Cycle: 85 sec.  
 Min. Delay: 30.21 sec/veh

Delay vs. Cycle Analysis

Delay (sec/veh)

Cycle Length

Update    OK    Cancel

To change the cycle length for this intersection, simply click on the Cycle Length text box in the upper right corner and type in “85” and then click on the Update button at the bottom of the screen. If you review the splits under the Timing Data folder, you will see that they have changed for the new cycle length.

If you would like to see a phase indication color-coded phasing diagram for your intersection, click on the Controller tab/folder. Phasing splits are shown for each phase in NEMA ring order, and yellow change and red clearance intervals are shown in proportion to their duration within each green split. A screenshot of this diagram can be found at the top of the following page.

Finally, you will want to review the measures of effectiveness, for your timing solution. MOEs are found under the Signal MOEs tab/folder and include delay (seconds per vehicle), level of service (LOS) [6] based on delay, v/c (volume to capacity) ratio, LOS based on v/c ratio, stops (per vehicle), average and maximum queue length (vehicles), and fuel consumption (gallons per hour) for each of the movements at your intersection. Make sure that you always check the MOEs to ensure that no movement or phase is experiencing a disproportionate amount of average delay or queue length. A screenshot of the Signal MOEs folder is shown on the next page for your reference.

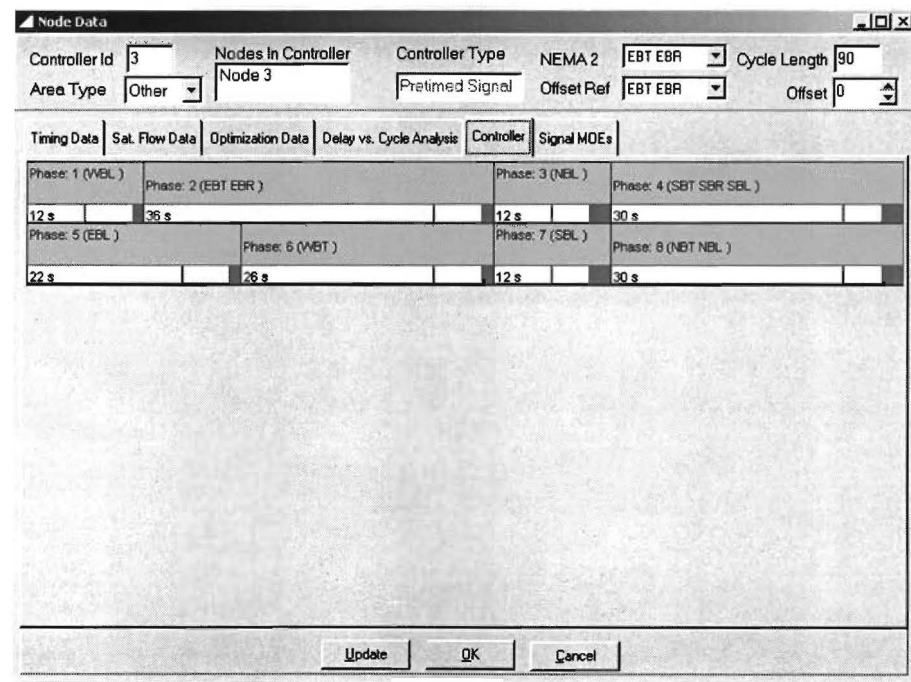

**Node Data**

Controller Id: 3    Nodes In Controller: Node 3    Controller Type: NEMA 2    EBT EBR    Cycle Length: 90  
Area Type: Other    Pre timed Signal    Offset Ref: EBT EBR    Offset: 0

Timing Data    Sat. Flow Data    Optimization Data    Delay vs. Cycle Analysis    Controller    Signal MOEs

Movement	EBL	EBT	EBR	WBL	WBT	WBR	SBL	SBT	SBR	NBL	NBT	NBR
Lane Assignment	1	3	1	1	3	0	1	2	1	1	2	0
Volume (vph)	149	676	97	44	635	0	19	68	75	113	80	0
SatFlow (pcphg)	1668.00	4775.00	685.00	1847.00	5706.00		1847.00	1944.00	1652.00	1728.00	3825.00	
Green Splits (sec)	22	36	36	12	26		12	30	30	12	30	
Delay (sec/veh)	37.17	23.02	27.91	42.95	30.63		39.40	24.17	24.76	76.65	23.44	
Delay LOS	D	C	C	D	C		D	C	C	E	C	
V/C Ratio	0.50	0.44	0.44	0.30	0.51		0.13	0.13	0.17	0.82	0.08	
V/C LOS	A	A	A	A	A		A	A	A	D	A	
Stops (stops/veh)	0.80	0.69	0.69	0.84	0.78		0.83	0.67	0.67	1.15	0.66	
Ave Queue (veh)	3.31	12.10	1.74	1.11	13.33		0.48	1.34	1.48	2.86	1.58	
Max Queue (veh)	3.68	14.36	2.06	1.14	15.21		0.49	1.40	1.56	3.08	1.62	
Fuel Consumption (g/hr)	3.24	12.08	1.84	1.04	13.01		0.43	1.23	1.37	3.76	1.46	

Update    OK    Cancel



## Diamond Interchange Analysis

*Using PASSER V to optimize timing for a signalized diamond interchange.*

Now that you have worked through an example problem for an isolated intersection, you are familiar with the PASSER V user interface and the locations of most of the data entry points within the program. Our next exercise will analyze a diamond interchange with a single controller. As a result of working on this problem, you will know how to code links that form an arterial roadway as well as how to analyze the special operational issues associated with diamond interchanges.

The diamond interchange we will use as our example is the diamond located at the junction of the East Bypass, SH6, and Harvey Road (FM 30) in College Station, Texas. The following two figures provide the geometric and turning movement details for the interchange.

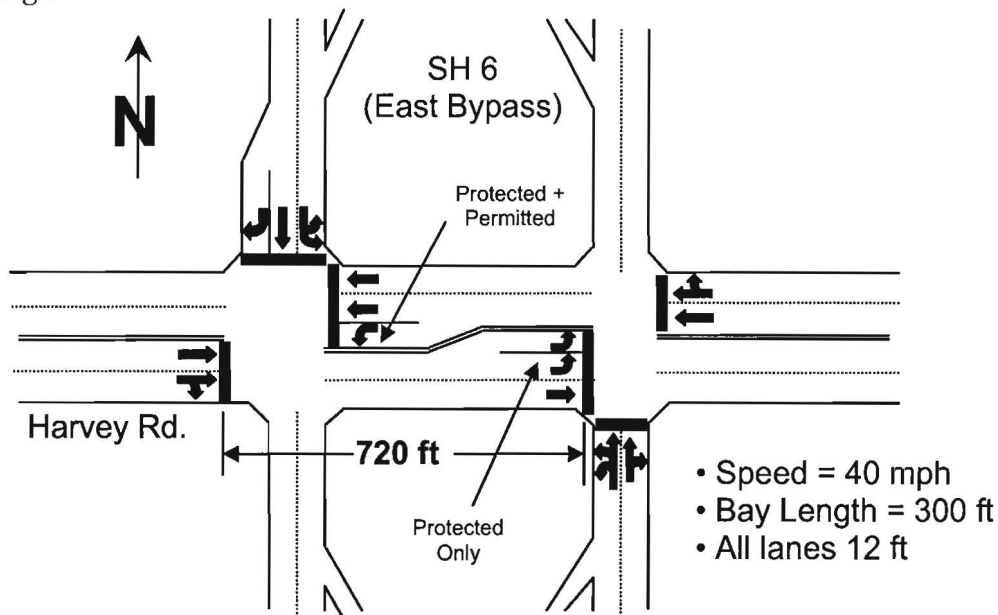

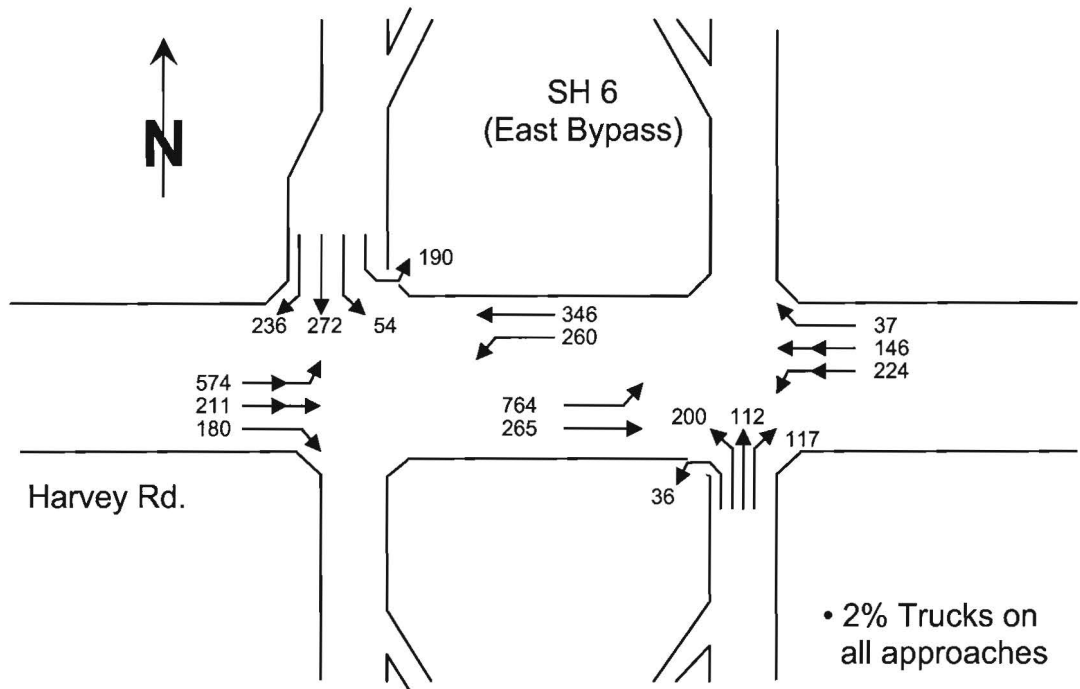

## Entering Data

Start PASSER V and create a new file. To make sure we are ready to save our work at any time, go ahead and click on 'File' and then 'Save As' and give this file the name "Diamond." Next, click on the System function button and enter in the project name, organization and your name. Then, click on the Two Way button from the function toolbar and draw a 2000-foot long east-west roadway for Harvey Road. Then, click on the One Way button (since we will be drawing one-way frontage roads) and draw a southbound frontage roadway such that it intersects Harvey Road about 3 grid squares (each grid square is 200 ft by default) to the left of center. Finally, draw a northbound frontage road such that it intersects Harvey Road 3.5 grid squares to the right of the southbound frontage road. When you are finished, your screen should look like the image below.

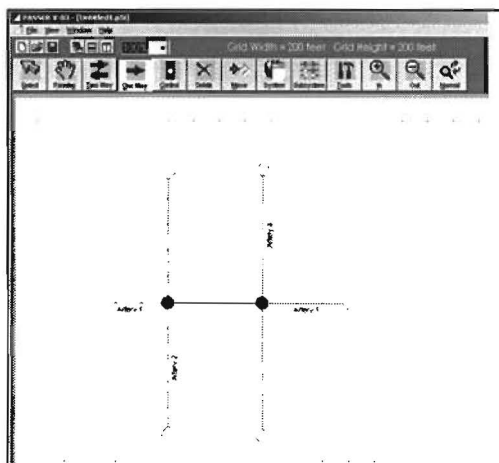

We next need to “clean up” the geometric details of the two-way link that joins the two sides of the diamond together. Click on the Select button from the function bar and click on the blue (interior) link of the interchange. A Link Data dialog box/window will appear where you edit properties of the link joining the two intersections. You will notice that PASSER V has automatically computed a length of 700 ft for the link based on the scale at which you drew the interchange. However, our true stop bar to stop bar distance along the arterial is 720 ft. Edit the link length in each direction and make it 720 ft. Then, edit the speed value from the default 30 mph to the 40 mph at our interchange. Check your intersection width values and enter 36 ft for the left intersection and 24 ft for the right intersection. Based on default frontage road lane geometry and the speed we entered, PASSER V has automatically calculated some parameters for the interior of the interchange, including the actual queue storage distance in the interchange interior and the travel time from one side of the diamond to the other (see figure below). When you have finished reviewing these details, click ‘OK.’

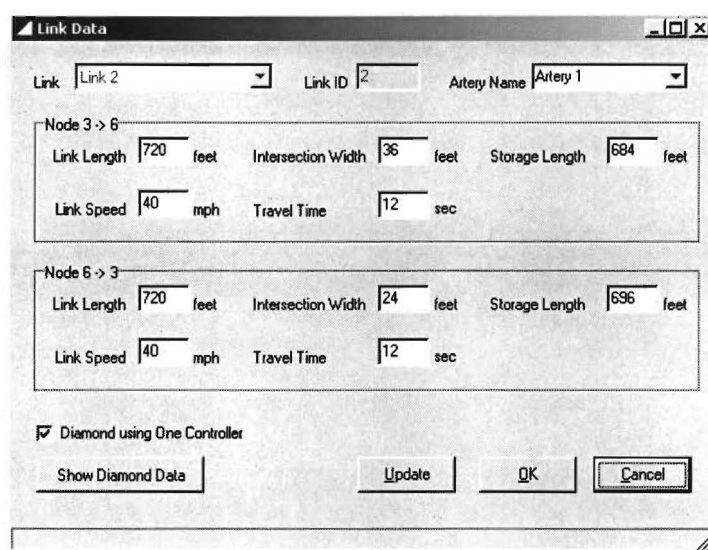

Notice that even though we changed the link distance, the nodes and links did not reposition themselves in our network plan view in PASSER V. This is an important point with respect to the PASSER V network editing window – changes in the graphic editor will result in changing link lengths in the data set; however, changing details in the data set (which PASSER V does retain and use for analytical purposes) by typing in new values in the Link Data dialog box **does not** result in a repositioning of network features in the user interface.

The next step in coding a diamond interchange is to “tell” PASSER V that the link between the two intersections is the interior link of an interchange. Click on the Select button and click on the interior link. At the bottom of the Link Data dialog box/window, you will see a check box labeled Diamond using One Controller. By placing a check mark in this box (by clicking on the box) you let PASSER V know to treat the two intersections joined by this link as a diamond interchange. After you have clicked on the check box, click on the button labeled “Show Diamond Data.” A Node Data window appears (see next page).



Node Data

Controller Id: 3    Nodes In Controller: Node 3, Node 6    Controller Type: NEMA 2    Cycle Length: 90

Area Type: Other    Presumed Signal    Offset Ref:    Offset: 0

Timing Data | Sat. Flow Data | Optimization Data | Delay vs. Cycle Analysis | Controller | Signal MOEs

Movement	EBT	EBR	WBL	WBT	SBL	SBT	SBR	EBL	EBT	WBT	WBR	NBL	N
Lane Assignment	0	0	0	0	0	0	0	0	0	0	0	0	0
Volume (vph)	100	100	100	100	100	100	100	100	100	100	100	100	1
Movement Type													
Left-turn Phasing													
Overlap?													
Minimum Green (sec)													
Yellow (sec)													
Red Clearance (sec)													
Lost Time (sec)													
Green Splits (%)													
Green Splits (sec)													

Optimization Settings: Lock Sat Flows  Lock Green Splits

Diamond Phasing:  Four Phase  Basic 3-Phase  Ext 3-Phase

Update    OK    Cancel

Notice from the figure above that the node data required by both intersections of the interchange are displayed simultaneously. A vertical red line separates the input data for one intersection from the other intersection. Another feature that makes an interchange different from a regular intersection is that a Diamond Phasing select box is available near the bottom center of the Node Data window. Using this selection box, you can tell PASSER V which phasing sequence you wish to use at this interchange. Note that only one selection is possible here, but when you optimize the interchange you can have PASSER V analyze all three options to find the most optimal signal timing solution. Also note that if you select the “Four Phase” option, a second editing box appears to the right. This box allows you to adjust the four-phase transition overlap time (also known as the internal overlap or the travel time overlap) from the PASSER V-calculated default value if you choose to do so. However, if you do make adjustments to this value make sure that you do not make the overlap greater than the value automatically calculated by PASSER V (since this could result in arterial vehicles from one side of the interchange arriving at the interior of the second intersection before the light is green to receive them – a possible violation of driver expectancy depending on interchange spacing and previous operation mode).

Similar to the data entry procedure that we used for an isolated intersection, we will now code the geometric, traffic volume/turning movement and signal setting details for the interchange. Remember as you enter right-turn volumes to remove right-turn volumes for right-turn lanes and bays of adequate length (i.e., not blocked by the through vehicle queue) by telling PASSER V that there is no right-turn movement for that approach. If some right turns on red are consistently likely (i.e., where a right-turn channel is provided without a bay), be sure to factor down the right-turn volume you enter by the number of right turning on red vehicles you expect in the peak hour. After you have finished with the geometric and volume details, your screen should look like the one on the next page.

Node Data

Controller Id: 3    Nodes In Controller: Node 3, Node 6    Controller Type: NEMA 2    Cycle Length: 90

Area Type: Other    Pretimed Signal    Offset Ref:    Offset: 0

Timing Data | Sat. Flow Data | Optimization Data | Delay vs. Cycle Analysis | Controller | Signal MOEs

Movement	EBT	EBR	WBL	WBT	SBL	SBT	SBR	EBL	EBT	WBT	WBR	NBL	NBT	NBR
Lane Assignment	2	1	1	2	1	1	0	2	1	2	1	1	2	1
Volume (vph)	785	180	260	346	244	272	0	764	265	370	37	236	112	117
Movement Type	Prot	Prot	Prot	Prot	Split	Prot		Prot	Prot	Prot	Prot	Split	Prot	Prot
Left-turn Phasing			Lead		Lead			Lead				Lead		
Overlap?	Yes			Yes		No			Yes	No			No	
Minimum Green (sec)	6	6	6	6	6	6		6	6	6	6	6	6	6
Yellow (sec)	3	3	3	3	3	3		3	3	3	3	3	3	3
Red Clearance (sec)	1	1	1	1	1	1		1	1	1	1	1	1	1
Lost Time (sec)	4	4	4	4	4	4		4	4	4	4	4	4	4
Green Splits (%)	0	0	0	0	0	0		0	0	0	0	0	0	0
Green Splits (sec)	0	0	0	0	0	0		0	0	0	0	0	0	0

Optimization Settings: Lock Sat Flows  Lock Green Splits

Diamond Phasing:  Four Phase  Basic 3-Phase  Ext 3-Phase

Update    OK    Cancel

Next, we need to enter the signal setting details for the interchange. We will assume that this interchange has pedestrian push buttons, so we do not need to manually calculate walk and clearance times to come up with our minimum phase times. Right turns on red are allowed on all approaches, but there are shared lanes for our eastbound, northbound, and westbound right-turn maneuvers with no turn bays or channels. Also, since this is a diamond interchange, the frontage road through and left-turn phases are intimately tied together and begin and end at the same time. This resembles split-phase operation, so we will select “Split” as our Movement Type for both frontage roads.

Because this interchange has rather wide spacing (greater than 400 ft), we know that we will probably be using a three-phase timing sequence. Therefore, we need to make our Left-turn Phasing “Lag”ging. We want all phase time to be used flexibly, so we will allow all phases to overlap. Finally, our speed is 40 mph on all approaches, resulting in yellow change intervals of 4 seconds and red clearance times that we will round up to 2 seconds.

The final details you need to check are the peak hour factor and heavy vehicle percentage, which are found behind the Sat. Flow Data tab. For this example we have not yet included the effects of peak hour factor on our volumes, so enter a value of 0.90 to account for some demand variability during the peak hour. Also, since our heavy vehicle percentage is 2 percent on all approaches (which is also the PASSER V default), we do not need to make any changes to truck percentage. Data entry for the interchange is complete!

Click back to the Timing Data tab and click on ‘Update’ at the bottom of the window. Splits for the movements at the interchange will be calculated and displayed. Keep in mind that these are splits based on one cycle length (shown in the upper right corner) and for only one of the three possible diamond interchange phasing sequences – we have not yet optimized

signal settings for the interchange. You can check under the Delay/Cycle Analysis tab to note that the default cycle length of 90 seconds actually experiences higher delay than cycle lengths around 55 seconds. The Controller tab will show you the splits for the interchange, and the Signal MOEs tab will give you delay and queue lengths for all of the movements in the interchange.

## Optimization

The next step in our analysis of an isolated diamond interchange is optimization. PASSER V makes a number of tools available to help you analyze a diamond. To access these tools, click on 'OK' to close the Node Data window and click on the Tools button from the PASSER V button bar. A new window entitled Optimization/Analysis Tools will appear. Within the left side of this window is a listing of the arteries in your network. In our case, only one artery exists, and it is the arterial portion of our interchange. Click on 'Artery 1', and the PASSER V interchange analysis tools tabs/folders will appear (see figure below). Note that the tools available are PASSER III (for analyzing diamond interchanges), GA Optimizer, Volume Analysis, T-Sp Diagram, and Delay/Cycle Analysis.

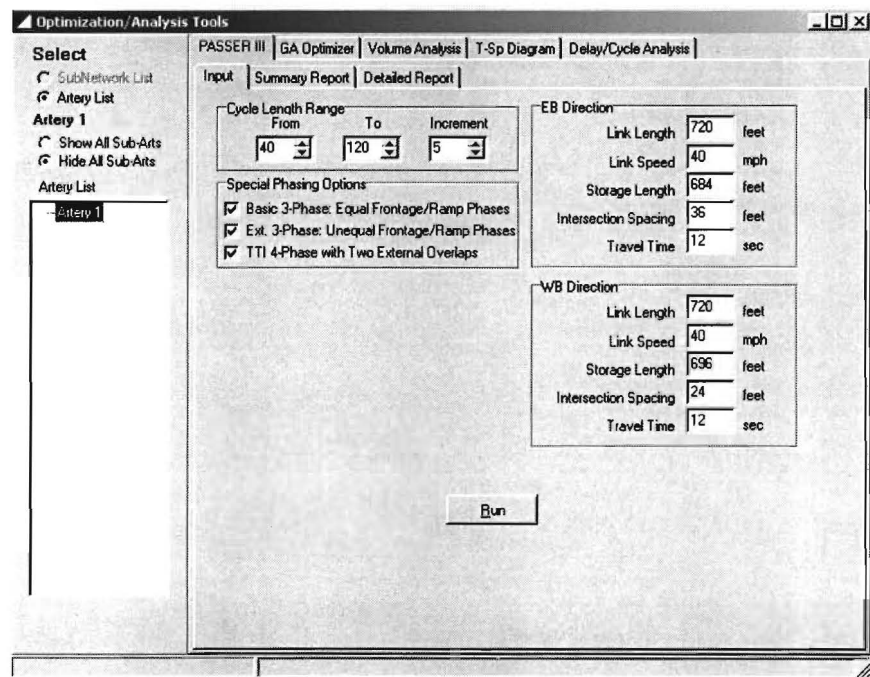

Since we do not know what cycle length range is most appropriate for our interchange, we should start by accessing the Delay/Cycle Analysis tab. Viewing its graph of cycle length (x-axis) versus delay (y-axis) we find that the optimal cycle length for the interchange is in the vicinity of 45 to 50 seconds. We can use this information to constrain the range of cycle lengths we analyze using other tools in PASSER V; a good range is probably 40 to 90 seconds, with a 5-second increment (rather than the 40- to 120-second range used as the default in PASSER V).

Next, let's look at the Volume Analysis tool. First, click on the 'Input Information' button beneath Volume Analysis and select a cycle length range of 40 to 90 seconds. Then, click on 'Chart.' You will see that for this example problem, all three-phase (Extended and Basic three-phase overlap each other on this graph) timing plans provide adequate capacity, or throughput, for this interchange (i.e., current volumes shown in red are beneath the throughput capacity limit, shown in yellow). For four-phase timing plans, a cycle length of at least 70 seconds (the junction of the red line for existing volumes and the capacity of the four-phase timing plan for each cycle length) is necessary to accommodate our volumes. If you wish, you can review the Critical Movement (i.e., movement having the high  $v/c$  ratio for each phasing sequence at each cycle length) and Throughput (table of throughput capacities shown in the graph) tabs for details on each cycle length and sequence analyzed.

Now that we know what cycle length range to analyze and we know in general that three-phase sequences have higher capacity than four-phase operation within our analysis range, we are ready to use PASSER III to analyze the interchange. Click on the PASSER III tab, and underneath the Input tab change the cycle length range to 40 to 90 seconds. Next, review your phasing sequence options for the interchange. Since we know that three-phase sequences are more appropriate for this interchange, we could reasonably turn off the four-phase analysis. However, for our example problem we will leave all phasing sequence options active. Also, check the details for the interchange in both the eastbound and westbound directions along the arterial. Note that you can edit speed of travel if you wish, that link length is broken down into its storage length (between intersections) and intersection spacing (intersection width) components, and that you can edit the travel time for the interior of the interchange if desired. Note that, especially for shorter interchange spacing, you do not want to increase the travel time, as this would result in (for a four-phase sequence) the platoon from an external approach on the arterial not having a green indication to receive them in the interior of the interchange – a potential violation of driver expectancy. However, you can decrease the travel time if you want the interior arterial approach of the interchange to start earlier with respect to the arrival of the platoon from the external arterial approach.

After you review all of your input information, click on 'Run' to activate the PASSER III optimization engine. A message will indicate that PASSER III is running, and it will disappear when the analysis is complete. Click on the Summary Report button to look at your output, which is organized from lowest delay to highest delay, with cycle length and phasing sequence details given. As it turns out, a 50-second cycle length, Extended three-phase sequence has the lowest delay (see figure at the top of the next page). To get more detailed information about the least-delay solution, click on 'Detailed Report' and view the details under the Art. Summary, Timing Plan, and MOEs tabs. Note (under Art. Summary) that the solution provides good progression and that attainability is 100 percent. Also note under MOEs that there is a wide discrepancy in the delays (LOS A to LOS E) experienced by different intersection movements. It is likely that a solution with a longer cycle length can help rectify these issues, even though average intersection delay will increase.

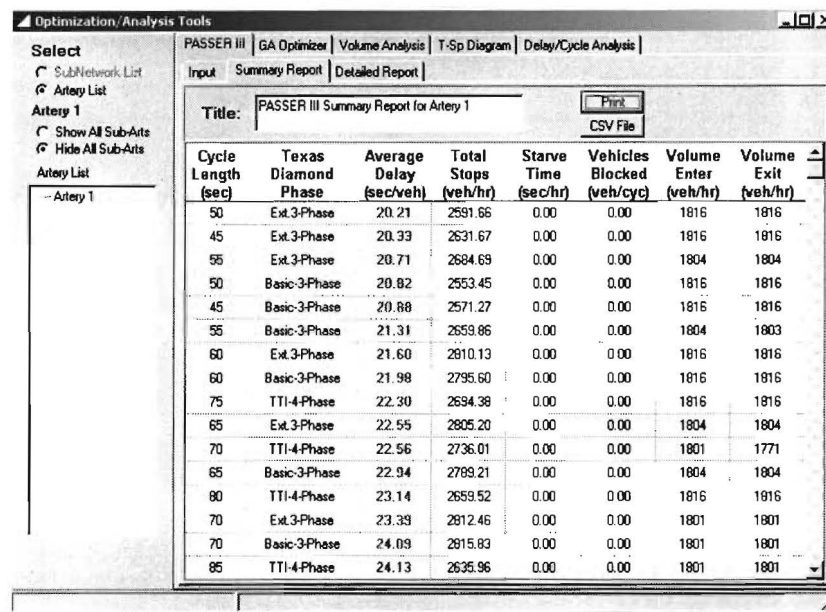

Click on the T-Sp Diagram tab to view a time-space diagram for the arterial within the interchange (see figure below). Note the T-Sp diagram shown is for the least delay solution, which for our case is the cycle length of 50 seconds and an Extended three-phase sequence. If you want to look at the time-space diagram for a different cycle length and/or phase sequence, you need to go back to the PASSER III tab under the Summary or Detailed Reports, right-click your mouse, and select the desired cycle length and phasing sequence. When you go back to the T-Sp Diagram tab, your selection's details will be displayed. Note from the figure that the source of the time-space diagram is PASSER III (i.e., PASSER III's least delay solution).

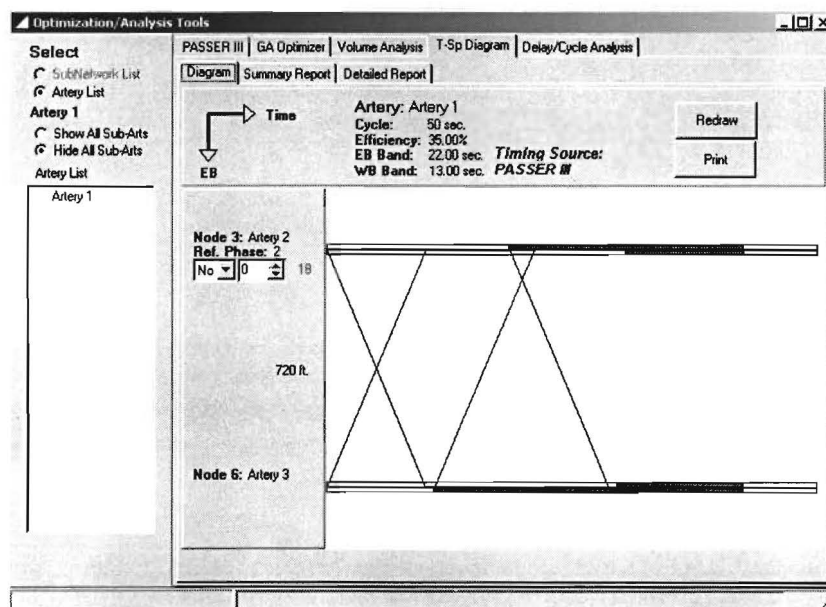

Now that we know how PASSER III interprets optimal operations at our interchange, let's look at using the GA Optimizer on our interchange. Click on the GA Optimizer tab and adjust the cycle length range down to 40 seconds to 90 seconds. Under fitness routine, select Delay-based rather than Bandwidth-based since this is an isolated diamond (i.e., we are not trying to create progression along the arterial through this interchange). Under GA Parameters, leave the default values. Finally, under Diamond Phase Sequence and Offsets, choose 'Optimize phase sequences for all diamonds' and 'Optimize offsets for all signals.' Note that if we had chosen to not optimize phase sequence or offset, the GA Optimizer would have used the settings we chose for the diamond during data entry. Or, if we had opted to let the GA Optimizer optimize according to individual interchange settings, it would have optimized either or both depending on whether we "locked" phase sequence or offset during data entry. You can review these settings by clicking on the Control button from the button bar, clicking on a node of the diamond, and selecting the Optimization Data tab. Options for locking the diamond phase sequence and offset are found at the bottom of the window.

Return to the GA Optimizer under the Tools button (if you left to check your diamond interchange input data) and check your settings. If you wish, you can click on the Adv. Options tab to change settings for the GA-based optimization (though this is not recommended). When you are ready, return to the Input tab (see next figure) under the GA Optimizer and click on 'Run.'

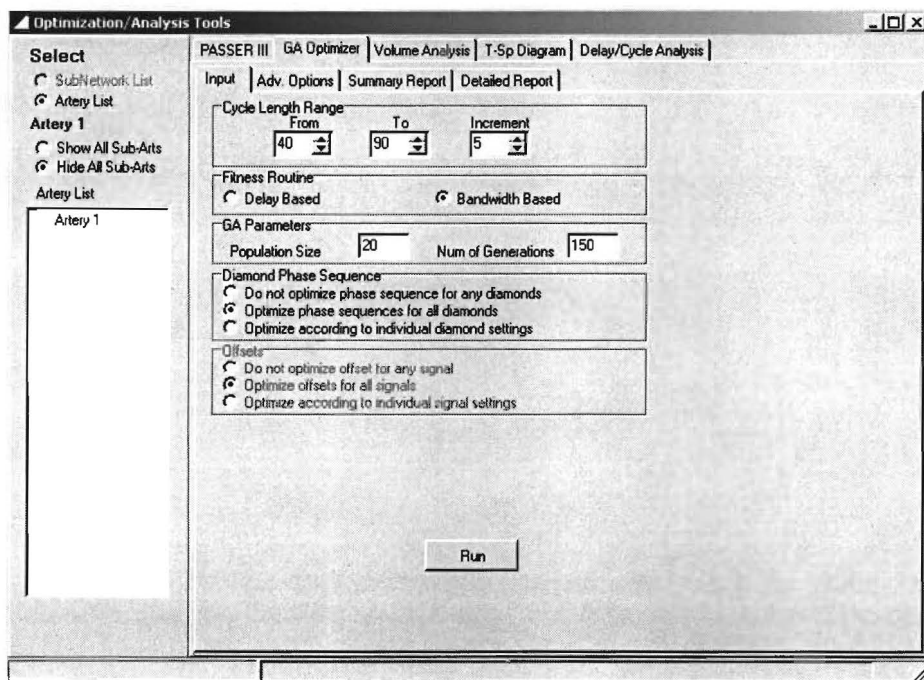

A progress bar at the bottom of the window indicates the optimization progress. When the optimization is complete, go to the Summary Report tab to see which cycle length and phase sequence the GA Optimizer selected. In our case, the optimal solution was the same 50-

second cycle identified by PASSER III. Note, however, that the GA Optimizer and PASSER III may not always identify the same cycle length and/or phase sequence as optimal. Under the Detailed Report, you can find such details as the timing plan for the 50-second, Extended three-phase solution and the MOEs, including delay for each movement, for the interchange. If you wish, you can choose to print any or all of these details by using the Print button in the upper right of the window within each tab/folder. Also, you can view a time-space diagram based on the GA solution by clicking on the T-Sp Diagram tab. GA Optimizer will be identified as the source of the time-space diagram being displayed.

Congratulations! You have now completed your first optimization analysis of a diamond interchange. For practice, you may want to go back and experiment with some of the features of the PASSER III or GA Optimizer tools and see what kinds of effects your changes make on the optimal solution. For instance, a 40-second cycle length is rather short for peak period operations. For practical reasons, you may want to use a cycle length no shorter than 60 seconds. To make this change, simply go back into the PASSER III and/or GA Optimizer tools and increase the lower bound on the cycle length range to 60 seconds. And, because of the wide spacing (720 ft) between these two halves of the diamond, you might want to just use a Basic three-phase or Extended three-phase solution in PASSER III. To remove the four-phase sequence from being an optimization option, simply go to the Input tab under PASSER III and remove the check mark next to the four-phase option.

When you are finished experimenting with the isolated diamond, move on to the next chapter to analyze multiple intersections along an arterial. For practical reasons, the example is limited to two intersections along an arterial for this class. However, using PASSER V you can analyze multiple arterials, each with many intersections. For convenience and/or consistency with your physical configuration in the field, you can even separate intersections along arterials into groups.

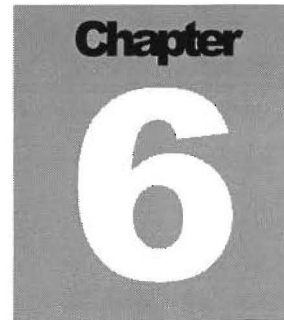

## Arterial Analysis

*Using PASSER V to analyze multiple intersections along an arterial roadway.*

Our next analysis task is to use PASSER V to optimize traffic operations along an arterial roadway. As we proceed through the process of data entry, analysis, and review of results for this multi-intersection example, we will be using features of PASSER V that we did not use for our isolated intersection or our diamond interchange.

### Entering Data

Begin your analysis by starting a new file and immediately saving the blank file as “Arterial.” PASSER V will automatically add a “.p5i” extension when it saves the input file. Then, click on the PASSER V System button and enter the name of the project, company, analyst, etc. Click on ‘OK’ when you are finished.

The next figure shows the details of two intersections along S.W. Military Drive in San Antonio, Texas. Our task is to develop a signal timing plan for both intersections that will provide for minimum delay and progressive flow between the two intersections. All data currently available are shown below. Before actual timings are developed for these two sites, detailed drawings should be made based on actual lane width measurements and current lane usage, and the intersection spacing should be measured in the field. The location and type of control of the intersections between our study intersections (if any) should be noted. If they are signalized, full turning movement counts and all other data must be obtained for these intersections as well so that they can be included in the PASSER V analysis.

Note that information about left-turn treatments/type (protected, permissive, both) is not indicated in the diagrams. You will have to make assumptions about the type of left-turn treatments (that information is not available to us for the time being, but you must have it before a complete analysis can be performed). We will assume protected/permitted operation on the crossing roadways and protected-only operation on S.W. Military.



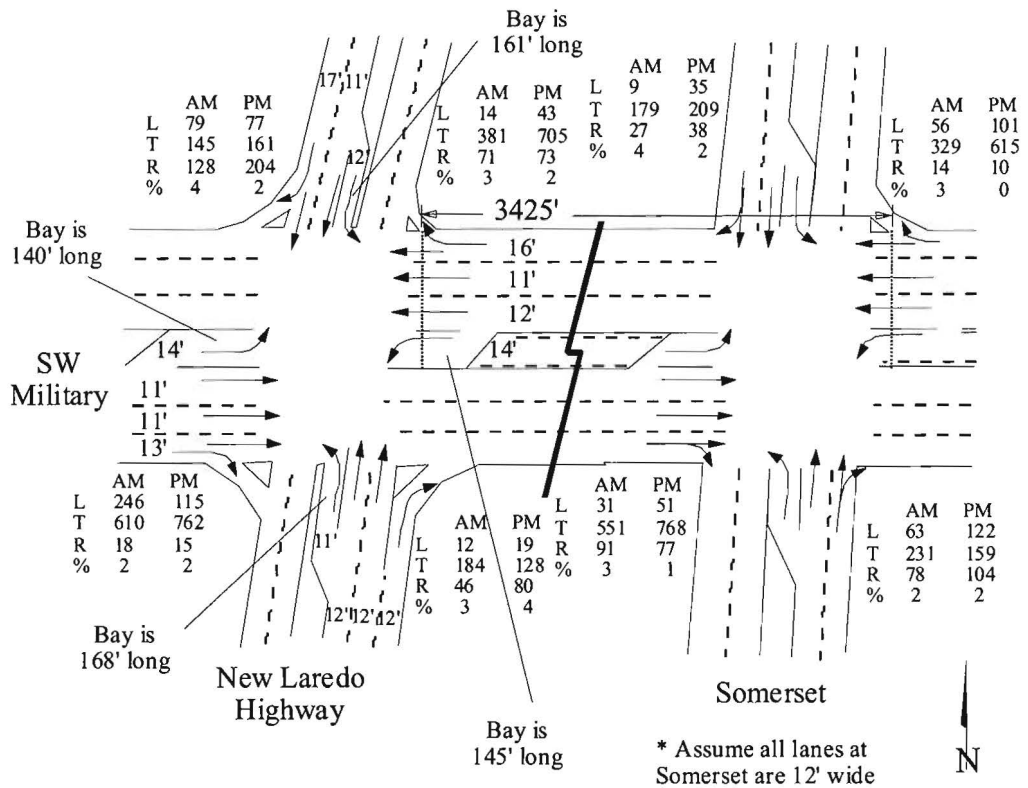

Another piece of information that is essential to an arterial, multiple intersection analysis is the average speed along the segment of roadway that links the analyzed intersections. If a speed that is too high is used in the analysis, the offsets will be set so that the platoon arrives late in the downstream intersection's main street through phase. If the speed entered is too low, the resulting offset will cause the platoon to arrive on red. A good approximation of the average speed is the speed limit. Field-based speed limit or average speed information must be obtained before appropriate steps can be taken to coordinate the intersections.

The PM peak hours tend to have slightly higher volumes than the AM peak, so we will start with a PM peak analysis. It is likely that separate timing plans will be necessary for the AM and PM peak periods, or that vehicle-actuated control for these intersections will be used. Since we are coordinating two or more intersections, we will have to have control hardware that is capable of operating in a pretimed coordinated or semi-actuated, coordinated mode. This may be implemented as a simple time-based coordinated system or it could be accomplished with a closed loop system (with wireline or radio communications between intersections). If the system is vehicle actuated, the loop detectors (or other sensors) must be calibrated and maintained.

To render the network of two intersections in PASSER V, begin by selecting the Two way link button and drawing a line 4500 ft long from left to right, approximately halfway down your screen. Then, draw a north-south crossing roadway such that it intersects the first

artery about 2½ grid squares (500 ft) from its left side. Repeat this procedure on the other side of the network for the crossing roadway to the east. When you are finished with these steps, your screen should resemble the following figure.

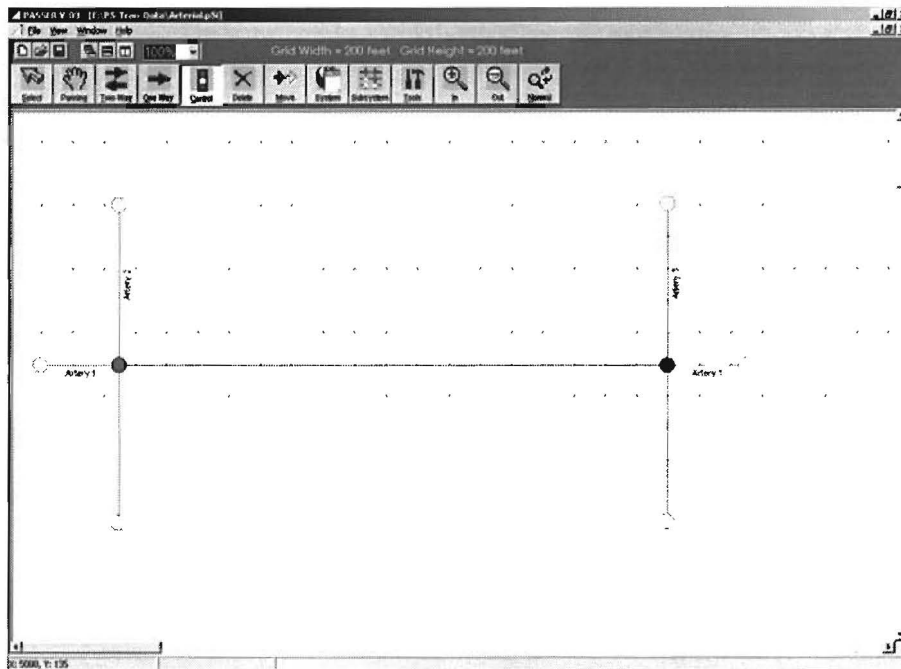

Our next task is to correct the length and other properties of the link joining our two intersections. Click on the Select button and then click on the link. Within the Link Data window that appears, edit the length so that it is 3425 ft in each direction. Also, edit the speed to make it 40 mph in each direction as this is our assumed speed along the primary artery, S.W. Military. Click on 'OK' when you are finished editing Link Data.

Next, click on the Control button and then click on the left intersection. Enter the data from the New Laredo Highway/S.W. Military intersection for this junction. Note that our rules for the right-turning volume that we used for an isolated intersection (Chapter 4) only apply to right turns onto non-coordinated arterials. For instance, at the New Laredo Highway intersection you would look at the right-turn volumes and conclude that both the eastbound and northbound right-turn volumes could be “zeroed out” since they could easily be handled as right turns on red or as right turns from their own turn lane. However, if you were to zero out the northbound right-turn volume, PASSER V would not be able to account for the flow profile and queuing that would result from those right-turning vehicles at the downstream arterial intersection. Thus, when you have right turns onto an arterial that you are analyzing in PASSER V for optimization, it is important to include at least some right-turn volume. In our case, we will include just enough of our northbound right-turning traffic that the right-turn volume does not influence signal timing at the intersection. A simple way to do this is to take the through volume for the same approach and divide it by the number of through lanes. In our case, this is 128 through vehicles divided by 2 lanes for a per lane through volume of 64 vehicles per hour. Apply the right-turn factor of 0.85 (from

the HCM) to this value to produce 54 ( $64 \times 0.85$ ), and use this value as the number of right turns. This includes some right-turn volume for use in flow and delay calculations in PASSER V, but not so much right-turn volume that the right-turn lane influences the split time for the through phase.

For the eastbound approach at New Laredo Highway, the right turns do not turn onto a coordinated arterial so we can simply not code a right-turn movement for this approach and/or set this right-turn volume to zero (i.e., all rights can be made through the channelized right-turn lane as right turns on red). For the southbound right turns, the rightmost lane will mainly be carrying only right-turning traffic, and at least half and perhaps up to 75 percent of right turns will get through on red. For the westbound approach, you might want to halve the right-turning volume due to the presence of the channel. Recall that left turns on S.W. Military are protected only, while those on New Laredo Highway are protected/permitted. Assume pedestrian buttons (min. green = 6 sec) for all approaches and use a yellow of 4 seconds and red clearance of 2 seconds. Under the Sat. Flow Data tab, use a PHF of 0.90 and use the truck percentages shown. When you are finished with data entry for this intersection, click on 'Update' and compare your input data to the screen on the next page. After resolving any differences, click on 'OK' and move on to the intersection at Somerset.

Movement	EBL	EBT	EBR	WBL	WBT	WBR	SBL	SBT	SBR	NBL	NBT	NBR
Lane Assignment	1	3	0	1	3	1	1	2	1	1	2	1
Volume (vph)	115	762	0	43	705	37	77	161	51	19	128	54
Movement Type	Prot	Prot		Prot	Prot	Prot	Prot+Per	Prot	Prot	Prot+Per	Prot	Prot
Left-turn Phasing	Lead			Lead			Lead			Lead		
Overlap?		Yes			Yes			Yes			Yes	
Minimum Green (sec)	6	6		6	6	6	6	6	6	6	6	6
Yellow (sec)	4	4		4	4	4	4	4	4	4	4	3
Red Clearance (sec)	2	2		2	2	2	2	2	2	2	2	1
Lost Time (sec)	4	4		4	4	4	4	4	4	4	4	4
Green Splits (%)	23.33	53.33		13.33	43.33	43.33	17.78	20.00	20.00	13.33	15.56	15.56
Green Splits (sec)	21	48		12	39	39	16	18	18	12	14	14

At Somerset, assume all lanes are 12 ft wide and that left-turn bays on each approach are 150 ft long. For right turns at Somerset, assume all westbound right turns can be handled as right turns on red (i.e., do not code a right-turn movement for this approach). On the other three approaches, the fact that the right lane is a shared lane with no channel will lead us to enter the full right-turn volume. Left turns on S.W. Military are protected only, while those on the cross street are protected+permitted. Also assume pedestrian buttons (min. green = 6 sec) for all approaches and use a yellow of 4 seconds and red clearance of 2 seconds.

Under the Sat. Flow Data tab, use a PHF of 0.90 and use the truck percentages shown. Check the figure below to confirm your input data for Somerset.

**Node Data**

Controller Id: 6    Nodes In Controller: Node 6    Controller Type: NEMA 2    Cycle Length: 90  
 Area Type: Other    Pretimed Signal    Offset Ref: EBT EBR    Offset: 0

Movement	EBL	EBT	EBR	WBL	WBT	WBR	SBL	SBT	SBR	NBL	NBT	NBR
Lane Assignment	1	3	1	1	3	0	1	2	1	1	2	1
Volume (vph)	51	768	77	101	615	0	35	209	38	122	159	104
Movement Type	Prot	Prot	Prot	Prot	Prot		Prot+Perr	Prot	Prot	Prot+Perr	Prot	Prot
Left-turn Phasing	Lead			Lead			Lead			Lead		
Overlap?		Yes			Yes			Yes			Yes	
Minimum Green (sec)	6	6	6	6	6		6	6	6	6	6	6
Yellow (sec)	4	4	4	4	4		4	4	4	4	4	4
Red Clearance (sec)	2	2	2	2	2		2	2	2	2	2	2
Lost Time (sec)	4	4	4	4	4		4	4	4	4	4	4
Green Splits (%)	14.44	41.11	41.11	17.78	44.44		13.33	20.00	20.00	21.11	27.78	27.78
Green Splits (sec)	13	37	37	16	40		12	18	18	19	25	25

Optimization Settings:  
 Lock Sat Flows   
 Lock Green Splits

Update    OK    Cancel

If you wish, you can check Delay vs. Cycle Analysis for each of the two intersections to note that the default cycle length of 90 seconds actually experiences higher delay than cycle lengths around 55 or 60 seconds. The Controller tab will show you the splits for each intersection, and the Signal MOEs tab will give you delay and queue lengths for all of the movements at each intersection.

## Optimization

When you are ready to optimize the arterial, close any open data entry or editing windows and click on the Tools button from the PASSER V function bar. Click on 'Artery 1' from the list of arteries on the left side of the Optimization/Analysis Tools window that appears. Notice that you now have access to the PASSER II arterial optimization tool and the GA Optimizer for arterial optimization. You can also use the Volume Analysis, T-Sp Diagram, and Delay/Cycle Analysis tools that we first used when analyzing a diamond interchange.

To begin our arterial optimization, we want to first find out what range of cycle lengths is most appropriate for our artery. Click on the Delay/Cycle Analysis tool and then click on 'Draw.' Notice that the minimum delay cycle is around 55 to 60 seconds; this is not surprising since the cycle lengths that we found were necessary for each intersection by itself both had minimum delay cycles around this value. We will make use of this information to constrain our cycle length range for analysis from the default of 40 to 120 seconds down to 40 to 90 seconds.

Next, we will use the Volume Analysis tool to find out how much throughput capacity we need to provide to avoid congestion problems on the artery (S.W. Military). After clicking on the Volume Analysis tab and then on 'Chart', you can see that as long as we provide a cycle length that is greater than about 50 seconds we will have enough capacity at the arterial intersections to accommodate our volumes.

Now that we know the cycle length range for our analysis, click on the PASSER II tool and enter a cycle length range from 40 to 90 seconds. We will use Volume Weighted Band under Options to have the PASSER II tool try and create progression bands in proportion to the amount of through traffic either eastbound or westbound on the artery (S.W. Military). Note that if we were specifically creating an AM or PM peak signal timing plan and we wanted to favor either eastbound (A direction) or westbound (B direction) traffic, we would select that direction underneath Options. Next, under MOE options we want PASSER to be able to make slight adjustments in offset to try and minimize intersection delay, rather than forcing the program to use only the exact offset for progression (i.e., delay savings can be realized without affecting progression quality in most instances). Finally, we want to look at MOEs for each cycle length, rather than just the output for the one, optimal cycle length.

When your PASSER II tool input data entry is complete, click on the Run button. PASSER V will indicate that the PASSER II tool is running; when it is complete, output results will appear to the right in the Input/Output tab. Notice that the PASSER II tool selects an 85-second cycle length for our artery, though the minimum delay cycle length is only around 60 seconds. This behavior in PASSER II is explained by the fact that the tool is trying to maximize bandwidth, or the amount of green time devoted to progression between intersections on the artery. Longer cycle lengths are one means of providing increased bandwidth while only slightly penalizing overall intersection delay. Click on the Summary Report tab to view the results for all of the cycle lengths analyzed. The report should resemble the following figure.

Cycle (sec)	Total Band (sec)	EB Band (sec)	WB Band (sec)	Total Eff. (%)	EB Eff. (%)	WB Eff. (%)	Total Att. (%)	EB Attain. (%)	WB Attain. (%)	Avg. Delay (sec/veh)	Total Stops (veh/hr)	Starve Time (sec/hr)	Vehicles Blocked (veh/cyc)	Entry Vol. (veh/hr)	Exit Vol. (veh/hr)
85	72.00	35.00	37.00	42.35	41.18	43.53	100.00	100.00	100.00	24.48	2552.96	0.00	0.00	1837	1854
90	76.00	37.00	39.00	42.22	41.11	43.33	100.00	100.00	100.00	25.79	2617.18	0.00	0.00	1853	1869
70	57.00	28.00	29.00	40.71	40.00	41.43	100.00	100.00	100.00	22.68	2617.07	0.00	0.00	1837	1883
65	52.00	26.00	26.00	40.00	40.00	40.00	100.00	100.00	100.00	22.32	2746.67	0.00	0.00	1840	1880
75	60.00	30.00	30.00	40.00	40.00	40.00	96.77	100.00	93.75	23.48	2686.06	0.00	0.00	1853	1890
80	64.00	33.00	31.00	40.00	41.25	38.75	94.12	100.00	88.57	23.35	2513.38	0.00	0.00	1853	1870
60	43.00	23.00	20.00	35.03	38.33	33.33	93.48	100.00	86.96	22.00	2950.66	0.00	0.00	1853	1935
55	32.00	18.00	14.00	29.09	32.73	25.45	84.21	94.74	73.68	22.12	3148.66	0.00	0.00	1840	1937
50	24.00	13.00	11.00	24.00	26.00	22.00	85.71	92.86	78.57	22.44	3372.69	0.00	0.00	1853	1868

By default, the results are organized by total efficiency (percent of bandwidth devoted to progression). Also notice, however, that in this case (as in most cases) longer cycle lengths are associated with higher overall average delay. A good compromise might be to select a 70-second cycle length to “get the best of both worlds.” Right-click your mouse over the output table and select the 70-second cycle timing plan. Then, click on ‘Detailed Report.’ You can review the details of this timing plan by clicking on the Art. Summary, Timing Plan, and MOEs buttons, and you can print each item if you wish.

To get an idea of how well progression is accommodated in our 70-second cycle length timing plan, click on the T-Sp Diagram tool. Your time-space diagram should look like the one below. Notice that the offset for the first (reference) intersection is 0 seconds and the offset for the second intersection (which in this case is Somerset) is 58 seconds. Also notice that large, equally sized progression bands exist in both directions. Such bands are characteristic of plans with good progression, and we were able to provide this quality of flow in both directions – at least during the PM peak period. Note for future reference that you cannot lock offsets when you do a PASSER II tool optimization analysis in PASSER V. However, under the settings for each individual intersection (select ‘Control’ and click on an intersection) you are able to specify a preference for a particular phasing sequence (left turns leading – LL or lagging – GG, lead/lag – LG or lag/lead – GL, All, or No – retain settings found under the Timing Data tab) under the Optimization Data tab.

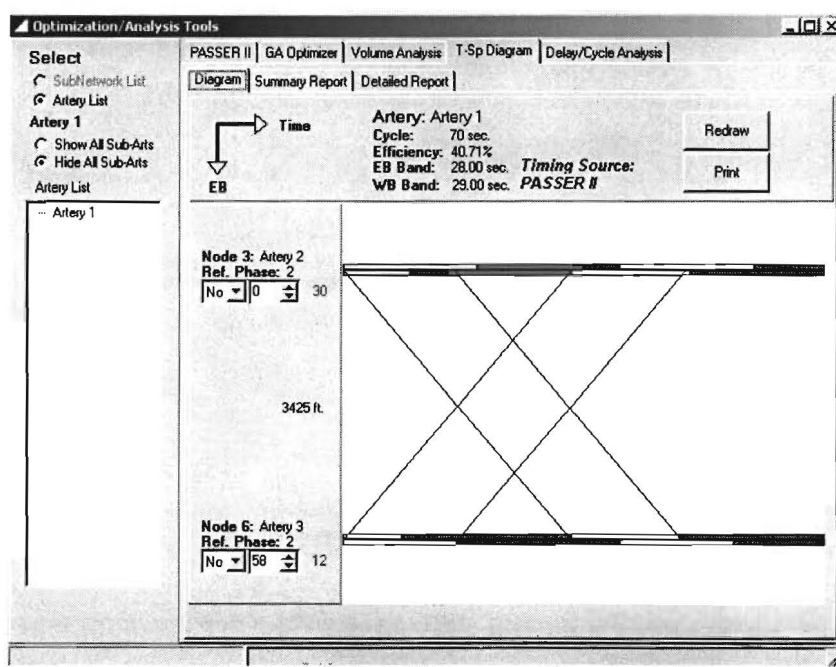

Now, we will use the GA Optimizer to view its interpretation of this same PM peak condition. To start the GA Optimizer analysis, click on the GA Optimizer tab. Enter our known cycle length range of 40 to 90 seconds. Also enter Bandwidth-based (rather than Delay-based) as the fitness routine so the results will be more directly comparable to the results from the PASSER II tool. From phase sequence options, opt to optimize both

phase sequence and offsets at all intersections. Click on 'Run' and when the GA Optimizer has finished its processing, click on the Summary Report tab. Notice that the GA Optimizer selected a 65-second cycle length in comparison to PASSER II, which selected the 90-second cycle length. In large measure, the GA Optimizer's "decision" was based on a thought process similar to our own, wherein we sought a timing plan with good progression, but not necessarily the longest cycle length available to us (since longer cycle lengths also have higher average delays). Note that if you were to run the GA tool with a larger population and number of generations, you would most likely evolve to a different but similar timing solution. As with the PASSER II tool, you can view and/or print the timing plan and MOE output details for the preferred solution, and you can go to the T-Sp Diagram tool to view the time-space diagram for the GA-based solution.

For comparison purposes, let's go back to the GA Optimizer Input tab and this time select Delay-based as our fitness routine. After you run the GA Optimizer, go to the Summary Report tab. Notice that based on delay (rather than bandwidth), the GA Optimizer has selected a 55-second cycle length. Again, this is not surprising since a 55-second cycle length is very close to the minimum delay cycle lengths for each of the two separate intersections. Note, however, in observing the T-Sp Diagram that using this shorter cycle length there is much less bandwidth and bandwidth efficiency in comparison to the bandwidth-based solution.

Considering all factors, the GA Optimizer using the Bandwidth-based fitness routine will usually provide the "best compromise" solution between delay and bandwidth. However, limitation on the GA tool at this point is that you cannot fix the phasing sequence (though you can fix offsets to optimize timing around a known/desired set of offsets) as you can with the PASSER II tool (by making selections under each intersection's Optimization Data tab). To review some of the details of the output for this timing solution, rerun the GA Optimizer (to restore the bandwidth-based solution) and click on 'OK' to close the Optimization/Analysis Tools window. Then, go to each intersection and review its timing details. Click on the Control button from the function bar and then click on the right intersection (New Laredo Highway/S.W. Military). Click on the Controller tab to view the ring structure for this intersection and do the same for the Somerset intersection.

Always be aware of all of the safety considerations discussed in this manual when you make final decisions about what type of timing plan you implement in the field. For instance, our optimal timing solutions included lead-lag phasing for the S.W. Military arterial. If we had allowed permitted left turns from S.W. Military, we could have created a "yellow trap" safety consideration. Before implementing any timing solution, you will want to review all pertinent phasing and configuration information to ensure that your recommendation is free of potential safety concerns and fully and appropriately meets the needs of the vehicles and pedestrians using the intersections. If you do find safety concerns, you can always make changes in your input file to remove those concerns and rerun your arterial in PASSER V.

## Combined Arterial and Diamond Analysis

*Optimize arterial operation, including progression through a diamond interchange.*

**W**e can maximize our use of PASSER V's functionality and tools by analyzing complex arterial operations that include diamond interchanges. PASSER V's GA Optimizer tool gives you the flexibility to optimize arterial progression while retaining the diamond interchange settings you already developed for a single controller (using the PASSER III tool on the interchange). This combines the utility of the previously separate tools PASSER II and PASSER III.

### An Example Problem

The figure on the following page presents an example optimization problem that includes a diamond interchange within an arterial. The arterial is geographically oriented north to south in the field, and was drawn that way in PASSER V. The diamond interchange (with one-way frontage roads) junctions are the third and fourth intersections from the top.

Along arterials with multiple intersections, you can make use of the subsystem, or grouping, features of PASSER V to organize your analysis. In this case, you can make the diamond interchange a subsystem and optimize it with the PASSER III tool. Then, by making the appropriate selections within the GA Optimizer for the overall arterial, you can retain the diamond phasing sequence for the interchange while creating progression bands (and optimizing signal settings for the other arterial intersections) for the overall arterial.



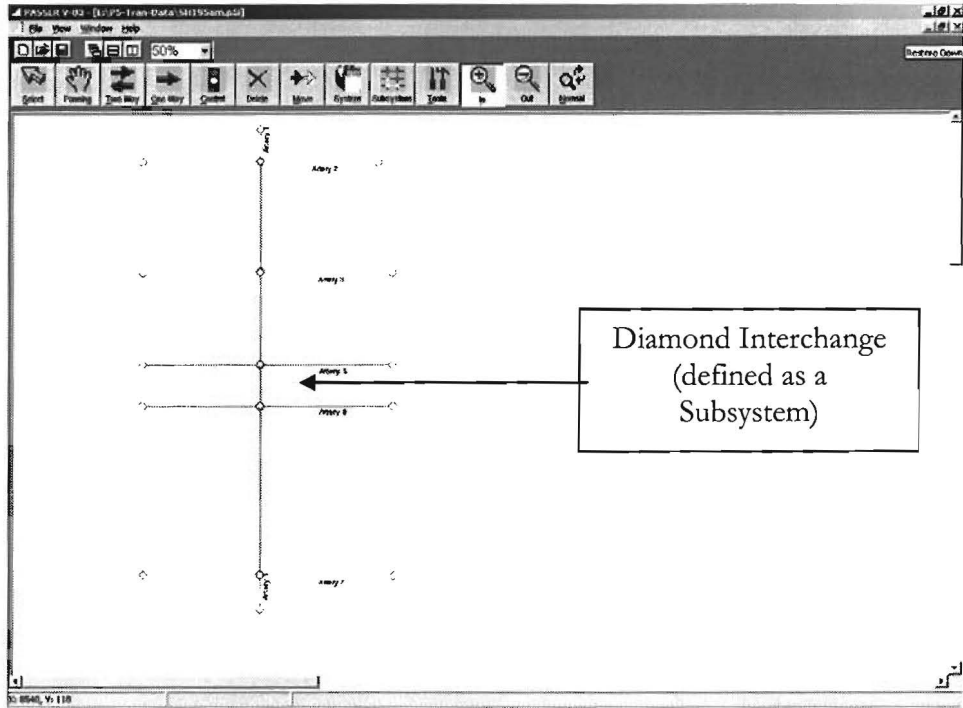

# References

1. *Manual on Uniform Traffic Control Devices*. Federal Highway Administration, United States Department of Transportation, 2003.
2. *Traffic Control Systems* (Standards Publication TS 1-1989). National Electrical Manufacturers Association, 1989 (revised 1994).
3. *Traffic Controller Assemblies* (Standards Publication TS 2-1992). National Electrical Manufacturers Association, 1992.
4. *Texas Diamond Controller Specification*. Traffic Operations Division, Texas Department of Transportation, 1998.
5. Messer, C.J. and M.S. Chang. "Traffic Operations of Basic Actuated Traffic Control Systems at Diamond Interchanges." Texas Transportation Institute Research Report 344-2F, 1985.
6. *Highway Capacity Manual 2000*. Transportation Research Board, National Research Council, Washington, D.C., 2000.
7. *Traffic Engineering Handbook*, 4<sup>th</sup> Edition. Institute of Transportation Engineers. Prentice-Hall, Inc. 1992.
8. McShane, W.R. and R.P. Roess. *Traffic Engineering*. Prentice-Hall, Inc. 1990.
9. "Determining Vehicle Signal Change and Clearance Intervals." ITE Technical Council Task Force 4TF-1, Institute of Transportation Engineers, Washington, D.C., 1994.
10. Gordon, R.L., R.A. Reiss, H. Haenel, E.R. Case, R.L. French, A. Mohaddes, and R. Wolcott. *Traffic Control Systems Handbook*. U.S. Department of Transportation, Federal Highway Administration, Washington, D.C., 1996.
11. *Traffic Detector Handbook*, Second Edition. Institute of Transportation Engineers, Washington, D.C., 1997.
12. NAZTEC, Inc. Internet site, <http://www.naztec.com/tecnotes/tn3013.htm>. Site and page accessed on September 26, 2002.

13. CORSIM. Version 1.03, *User's Manual*, Kaman Science Corporation, Colorado Springs, Colorado 80933-7463, April 1997.
14. *TRANSYT 7F User's Guide*. Methodology for Optimizing Signal Timing: MOST Volume 4. University of Florida, Gainesville, Florida, March 1998.
15. Husch, D., and J. Albeck. *Synchro 4.0 User Guide*. Albany, California, 1999.
16. Chang, E.C., and C.J. Messer. *Arterial Signal Timing Optimization Using PASSER II-90, Program User's Manual*, TTI Report 467-2F, College Station, Texas, June 1991.
17. Messer, C.J., R.H. Whitson, C.L. Dudek, and E.J. Romano. A Variable-Sequence Multiphase Progression Optimization Program. In *Transportation Research Record 445*, TRB, National Research Council, Washington, D.C., 1973, pp. 24-33.
18. Venglar, S., P. Koonce, and T. Urbanik II. *PASSER III<sup>TM</sup>-98 Application and User's Guide*. Texas Transportation Institute, College Station, Texas, 1998.
19. Wagner, F.A., D.L. Gerlough, and F.C. Barnes. *Improved Criteria for Traffic Signals on Urban Arterials*. NCHRP Report 73, 1969.
20. Chaudhary, N. and C.J. Messer. *PASSER IV-96, Version 2.1 User/Reference Manual*. TTI Report 1477-1, College Station, Texas, October 1996.
21. Chaudhary, N., V. Kovvali, C. Chu, J. Kim, and S. Alam. *Software for Timing Signalized Arterials*. TTI Report 4020-1, College Station, Texas, September 2002.
22. Kovvali, V. *Development of a Robust Arterial Coordination Software*. Ph.D. Dissertation, Dept. of Civil Engineering, Texas A&M University, College Station, Texas, December 2001.
23. Wall, M. *Introduction to Genetic Algorithms*, <http://lancet.mit.edu/~mbwall/presentations/IntroToGAs/>. Accessed May 8, 2001.
24. Webster, F. V., and B. M. Cobbe. *Traffic Signals*. Road Research Laboratory, Technical Paper 56, Her Majesty's Stationary Office, London, 1966.
25. Akcelik, R. *Traffic Signals: Capacity and Timing Analysis*. ARR 123, Australian Road Research Board, Victoria, March 1981.
26. Chaudhary, N. C. Chu, K. Balke, and V. Kovvali. *Coordination of Diamond Interchanges with Adjacent Traffic Signals*. TTI Report 4913-1, College Station, Texas, October 2000.
27. Jain, S. *An Enhanced Model for Calculating Delay as a Function of Offset*. M.S. Thesis, Texas A&M University, College Station, Texas, 1996.
28. Kell, J. and I. Fullerton. *Manual of Traffic Signal Design*, Institute of Transportation Engineers, Washington, D.C., 1991.

29. *Manual of Transportation Engineering Studies.* Institute of Transportation Engineers, Washington, D.C., 1994.

The “yellow trap” emerges when the leading left in permissive mode and its corresponding through movement are being terminated through their clearance intervals so that the opposing direction’s lagging left turn can receive its protected arrow. Drivers on the leading left-turn approach will see that the through movement in their direction of travel is being terminated through its clearance interval at the same time the permissive green for their left turn is being terminated, and may think that the through movement in the opposing direction is being terminated as well. If such drivers decide to try and “sneak” through the intersection on the yellow, they are directly in the path of opposing through vehicles that still have a green signal indication. In fact, the opposing through movement remains green and will be displayed with the opposing direction’s protected left-turn arrow. The phasing sequence leading up to the yellow trap is depicted below.

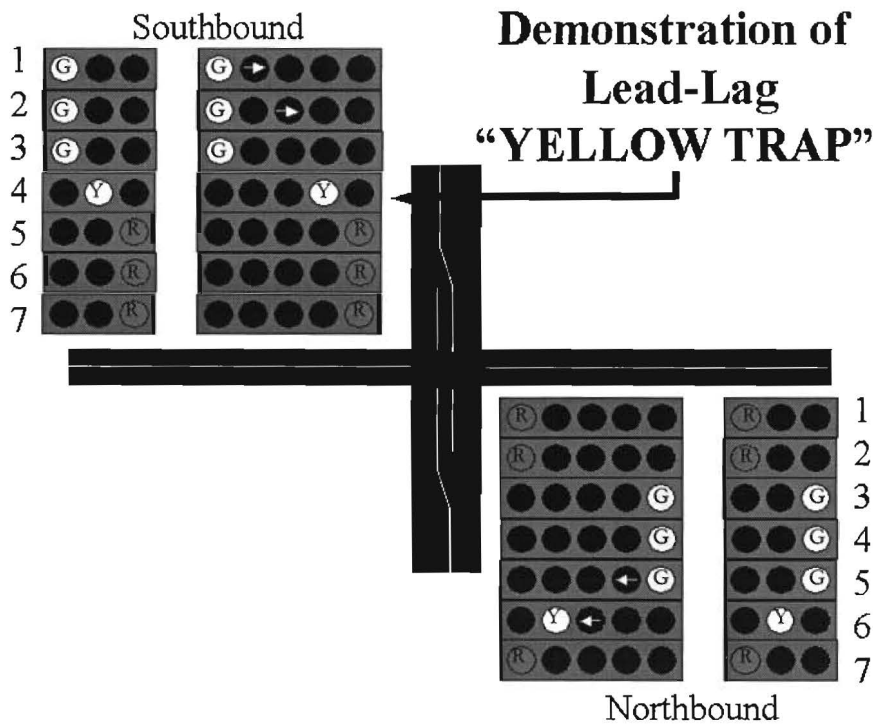

One solution to the yellow trap problem associated with protected-permissive lead-lag phasing is to use “Dallas” phasing, which maintains the permissive left turn from the leading direction until the opposing direction’s through movement terminates. This type of operation is shown in the following figure.

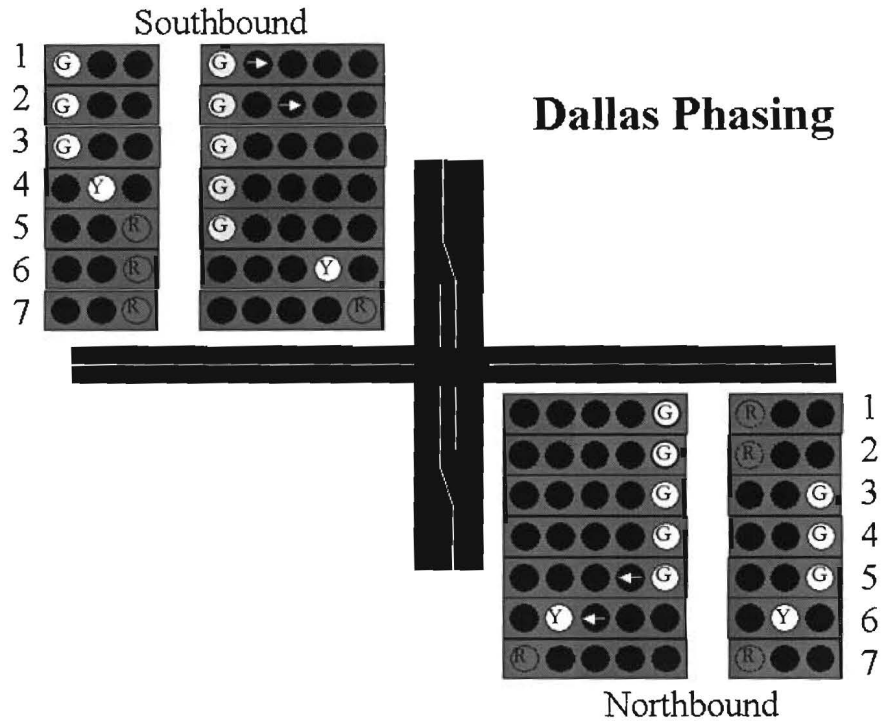

Note that the use of protected-permissive lead-lag phasing is not the only phasing situation that can create the yellow trap problem. In semi-actuated or fully actuated operation, the skipping of the cross street phases can also result in situations where a permissive left-turn phase in one direction is terminated while the opposing direction's through movement remains green. To remedy these situations, a minimum recall can be placed on cross street phases, or phase inhibit functions can be used to ensure that the phasing situation that causes the yellow trap situation does not occur. For instance, using phase 2 to inhibit phase 1, phase 4 to inhibit phase 3, phase 6 to inhibit phase 5, and phase 8 to inhibit phase 7 you can eliminate the sequence of phase indications that result in a yellow trap. However, it is important to note that the inhibit functions are not consistent with the use of lead-lag (or lag-lag) phasing, since the applied inhibits would always not allow the lagged left-turn phase to be displayed (i.e., phase 2 inhibiting phase 1 would always not allow phase 1 to become active if phase 1 is lagging). Lead-lag phasing yellow trap solutions include the Dallas phasing option mentioned earlier or using protected operation only for the leading left.

If both opposing left-turn displays are protected-only, you should only apply a dual lag/lag left-turn sequence if max calls are placed on the through phases and min recalls are placed on the left-turn phases to ensure that the lag turns begin simultaneously – otherwise you could create a yellow trap situation if one of the protected left-turn phases is skipped. As a general rule when using standard eight-phase operation, if you inhibit phase 1 with phase 2, phase 3 with phase 4, phase 5 with phase 6, and phase 7 with phase 8, you will ensure that the “yellow trap” never occurs in a protected/permitted left-turn display. You can safely lag a left-turn phase by following this rule: Lift the “Inhibit Phase” if the opposing left turn is protected only [12].