



TEXAS
TRANSPORTATION
INSTITUTE

STATE DEPARTMENT
OF HIGHWAYS AND
PUBLIC TRANSPORTATION

COOPERATIVE
RESEARCH

**LONGITUDINAL BARRIERS FOR
BUSES AND TRUCKS
STATE-OF-THE-ART**

in cooperation with the
Department of Transportation
Federal Highway Administration

**RESEARCH REPORT 416-2F
STUDY 2-5-83-416
BRIDGE RAIL**

1. Report No. FHWA/TX-86/32+416-2F		2. Government Accession No.		3. Recipient's Catalog No.	
4. Title and Subtitle LONGITUDINAL BARRIERS FOR BUSES AND TRUCKS STATE OF THE ART				5. Report Date February 1986	
				6. Performing Organization Code	
7. Author(s) T. J. Hirsch, Research Engineer & Principal Investigator				8. Performing Organization Report No. Research Report 416-2F	
9. Performing Organization Name and Address Texas Transportation Institute Texas A&M University System College Station, Texas 77843				10. Work Unit No.	
				11. Contract or Grant No. Study No. 2-5-83-416	
12. Sponsoring Agency Name and Address Texas State Dept. of Highways and Public Transportation; Transportation Planning Division; P.O. Box 5051; Austin, Texas 78763				13. Type of Report and Period Covered Final - September 1982 February 1986	
				14. Sponsoring Agency Code	
15. Supplementary Notes Research performed in cooperation with DOT, FHWA Research Study Title: Modified Type T4 Bridge Rail to Redirect Buses and Trucks					
16. Abstract <p>In May 1976 two significant accidents occurred involving longitudinal barriers. An ammonia truck in Houston, Texas, struck a bridge rail, leaving 11 dead, 73 hospitalized, and causing 100 other injuries, for a total of 184 casualties. In Martinez, California, a school bus struck a bridge rail and left 29 dead and 23 injured. As a result of these accidents, an extensive effort has been made to develop longitudinal barriers capable of restraining and redirecting buses and large trucks.</p> <p>The results of 34 crash tests conducted using cars and mostly buses and trucks on 16 different longitudinal barriers were obtained from the references. Vehicles represented are 4,500 lb passenger cars, a 4,000 lb van or light truck, 20,000 lb school buses, 32,000 to 40,000 lb intercity buses, and 40,000 to 80,000 lb tractor-trailer trucks. Results of these crash tests are summarized.</p> <p>Theory and crash test results are presented to demonstrate the magnitude of the impact forces these longitudinal barriers must resist and how high they must be to prevent vehicle rollover.</p> <p>Typical designs of longitudinal barriers which have been successfully crash tested in accordance with recommended procedures are presented.</p>					
17. Key Words Longitudinal Barriers, Bridge Rails, Median Barriers, Highway Safety, Buses, Trucks, Heavy Vehicles			18. Distribution Statement No restriction. This document is available to the public through the National Tech. Information Service, 5285 Port Royal Road, Springfield, Virginia 22161		
19. Security Classif. (of this report) Unclassified		20. Security Classif. (of this page) Unclassified		21. No. of Pages 22	22. Price

**LONGITUDINAL BARRIERS FOR BUSES AND TRUCKS
STATE OF THE ART**

by

**T. J. Hirsch
Research Engineer & Principal Investigator**

**Research Report 416-2F
on
Research Study No. 2-5-83-416
Modified Type T5 Bridge Rail to Redirect Buses and Trucks**

Sponsored by

**Texas State Department of Highways and Public Transportation
in cooperation with
the U.S. Department of Transportation
Federal Highway Administration**

August 1985

**Texas Transportation Institute
The Texas A&M University System
College Station, Texas 77843**

METRIC CONVERSION FACTORS

Approximate Conversions to Metric Measures

Symbol	When You Know	Multiply by	To Find	Symbol
LENGTH				
in	inches	*2.5	centimeters	cm
ft	feet	30	centimeters	cm
yd	yards	0.9	meters	m
mi	miles	1.6	kilometers	km
AREA				
in ²	square inches	6.5	square centimeters	cm ²
ft ²	square feet	0.09	square meters	m ²
yd ²	square yards	0.8	square meters	m ²
mi ²	square miles	2.6	square kilometers	km ²
	acres	0.4	hectares	ha
MASS (weight)				
oz	ounces	28	grams	g
lb	pounds	0.45	kilograms	kg
	short tons (2000 lb)	0.9	tonnes	t
VOLUME				
tsp	teaspoons	5	milliliters	ml
Tbsp	tablespoons	15	milliliters	ml
fl oz	fluid ounces	30	milliliters	ml
c	cups	0.24	liters	l
pt	pints	0.47	liters	l
qt	quarts	0.95	liters	l
gal	gallons	3.8	liters	l
ft ³	cubic feet	0.03	cubic meters	m ³
yd ³	cubic yards	0.76	cubic meters	m ³
TEMPERATURE (exact)				
°F	Fahrenheit temperature	5/9 (after subtracting 32)	Celsius temperature	°C

Approximate Conversions from Metric Measures

Symbol	When You Know	Multiply by	To Find	Symbol
LENGTH				
mm	millimeters	0.04	inches	in
cm	centimeters	0.4	inches	in
m	meters	3.3	feet	ft
m	meters	1.1	yards	yd
km	kilometers	0.6	miles	mi
AREA				
cm ²	square centimeters	0.16	square inches	in ²
m ²	square meters	1.2	square yards	yd ²
km ²	square kilometers	0.4	square miles	mi ²
ha	hectares (10,000 m ²)	2.5	acres	
MASS (weight)				
g	grams	0.035	ounces	oz
kg	kilograms	2.2	pounds	lb
t	tonnes (1000 kg)	1.1	short tons	
VOLUME				
ml	milliliters	0.03	fluid ounces	fl oz
l	liters	2.1	pints	pt
l	liters	1.06	quarts	qt
l	liters	0.26	gallons	gal
m ³	cubic meters	35	cubic feet	ft ³
m ³	cubic meters	1.3	cubic yards	yd ³
TEMPERATURE (exact)				
°C	Celsius temperature	9/5 (then add 32)	Fahrenheit temperature	°F

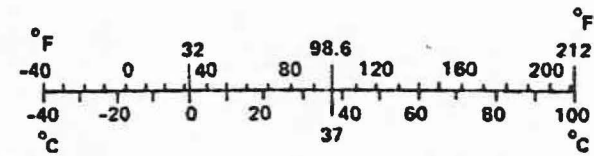

* 1 in = 2.54 (exactly). For other exact conversions and more detailed tables, see NBS Misc. Publ. 286, Units of Weights and Measures, Price \$2.25, SD Catalog No. C13.10:286.

DISCLAIMER

The contents of this report reflect the views of the author, who is responsible for the opinions, findings, and conclusions presented herein. The contents do not necessarily reflect the official views or policies of the Federal Highway Administration. This report does not constitute a standard, specification, or regulation.

KEY WORDS

Longitudinal Barriers, Bridge Rails, Highway Safety, Trucks, Buses, Heavy Vehicles

ACKNOWLEDGMENTS

This research study was conducted under a cooperative program between the Texas Transportation Institute (TTI), the State Department of Highways and Public Transportation (SDHPT), and the Federal Highway Administration (FHWA). The author appreciates the support and encouragement of these agencies.

IMPLEMENTATION STATEMENT

As of the writing of this report, several of the longitudinal barriers discussed have and are being built on Texas and various other state highways.

TABLE OF CONTENTS

	<u>Page</u>
INTRODUCTION	1
BASIC MOTOR VEHICLE AND LONGITUDINAL BARRIER PROPERTIES TO BE CONSIDERED	6
STRENGTH REQUIREMENTS OF LONGITUDINAL BARRIERS	11
HEIGHT REQUIREMENTS OF LONGITUDINAL BARRIERS	15
SUMMARY AND CONCLUSIONS	19
REFERENCES	20
APPENDIX A - GLOSSARY	22

LIST OF TABLES

<u>Table No.</u>		<u>Page</u>
1	SUMMARY OF VEHICLE TEST RESULTS	3

LIST OF FIGURES

<u>Fig. No.</u>		<u>Page</u>
1	BASIC PROPERTIES OF PASSENGER CAR AND EFFECTIVE LONGITUDINAL BARRIERS	7
2	BASIC PROPERTIES OF BUSES AND TWO EFFECTIVE LONGITUDINAL BARRIERS	8
3	BASIC PROPERTIES OF TRACTOR-TRAILER TRUCKS (VAN AND TANK TYPES) AND SOME LONGITUDINAL BARRIERS WHICH HAVE RESTRAINED AND REDIRECTED THEM	9
4	MATHEMATICAL MODEL OF VEHICLE-BARRIER RAILING COLLISION	12
5	COMPARISON OF VEHICLE IMPACT FORCES TO TOTAL VEHICLE WEIGHT-THEORY AND TEST RESULTS-STIFF RAILS	14
6	APPROXIMATE ANALYSIS OF REQUIRED BARRIER EFFECTIVE HEIGHT TO PREVENT VEHICLE FROM ROLLING OVER BARRIER	16
7	COMPARISON OF REQUIRED BARRIER HEIGHT TO VEHICLE CENTER OF GRAVITY-THEORY AND TEST RESULTS	17

INTRODUCTION

In May 1976 two significant accidents occurred involving longitudinal barriers. An ammonia truck in Houston, Texas, struck a bridge rail and fell on traffic below, leaving 11 dead, 73 hospitalized, and causing 100 other injuries, for a total of 184 casualties. In Martinez, California, a school bus struck a bridge rail and fell upside down, leaving 29 dead and 23 injured. As a result of these accidents, an extensive effort has been made to develop longitudinal barriers capable of restraining and redirecting buses and large trucks.

Prior to 1956 when the Interstate Highway Act was passed by Congress, most of our highway bridges crossed over rivers, streams, or other natural features. Few highways had traffic lanes divided or separated by median barriers. Longitudinal barriers such as bridge rails, median barriers, and guardrails were designed only to restrain and redirect passenger cars. It was the general attitude that buses and trucks were driven by trained, skilled, and professional drivers, and sensational longitudinal barrier accidents with buses and trucks were rare.

Since 1956 we have built tens of thousands of miles of divided traffic lane interstate highways, urban expressways, and freeways. Most of the bridges on these systems are grade separation structures which cross over other densely populated traffic lanes. In addition with the demise of our railroads and the increase in school busing, there has been a significant increase in the number of buses and trucks on our roadways. Consequently, the number of sensational bus and truck accidents involving longitudinal barriers has increased. Many highway engineers now believe that there are selected locations where barriers capable of restraining and redirecting buses and trucks are needed.

A search of the recent literature (1972 to 1985) yields fourteen references with 34 crash tests into longitudinal traffic barriers which were conducted essentially in accordance with current recommended practice (6)*. These crash tests used cars, vans, buses, and trucks ranging in weight from approximately 4,000 lb to 80,000 lb. In general, the passenger car and van tests were conducted at 60 mph and 25° angle into the longitudinal barriers. The school and intercity buses weighed from 20,000 to 40,000 lb, and tests with these vehicles were conducted at 60 mph and 15° angle into the longitudinal barriers. The tractor-trailer trucks weighed from 40,000 to 80,000 lb and were crash tested at 50 mph and 15° angle into the barriers. A summary of these vehicle crash test results is presented in Table 1.

These crash test results and some elementary theory are presented to demonstrate the magnitude of the impact forces these longitudinal traffic barriers must resist and also how high these barriers must be to prevent vehicle rollover. In addition, typical designs are presented on Figures 1, 2, and 3 of longitudinal barriers which have been successfully crash tested in

* Numbers in parentheses, thus (6), refer to corresponding items in the reference list.

TABLE 1. SUMMARY OF VEHICLE TEST RESULTS

Author (Reference)	Test No.	Test Condition Veh.-CG in. Veh. Wt.-Speed-Angle lb-mpg-degrees	Max. Avg. 0.05 sec Force		Height of		Barrier and Remarks
			Load Cells kips	Accelerometer kips	Resultant in.	Barrier in.	
Noel (7 & 22)	3451-32	Plymouth-22 4680-52.9-15	52.1	43.6	21.2	42	Concrete Wall; Smooth redirection.
Noel (7 & 22)	3451-36	Plymouth-22 4740-59.9-24	59.9	69.6	21.9	42	Concrete Wall; Smooth redirection.
Buth (16)	4798-7	Dodge Van-30 3983-59.2-24	-	20.0	-	27	W-beam Guardrail-2.34 ft defl.; Van rolled over 270°.
Buth (22)	3451-9	School Bus-50-43* 19,940-55.2-15	-	83.7	-	27	Reinf. W-Beam Bridge Rail; Redirection, front axle stripped.*
Buth (22)	3451-10	School Bus-50-43* 20,010-52.0-13.3	-	70.1	-	27	Reinf. W-Beam Bridge Rail; Redirection, front axle stripped.*
Buth (22)	3451-11	Intercity Bus-46 31,880-58.4-16	-	63.8	-	27	Reinf. W-Beam Bridge Rail; Redirection, bus rolled over.
Buth (22)	3451-4	School Bus-50 19,760-59.8-14.3	-	102.8	-	30	6x8 in. Steel Tube on 9 in. Conc. Parapet; Redirection, bus rolled over.
Buth (22)	3451-23	School Bus-50 19,920-57.3-14.8	-	97.6	-	32	4 in. Alum. Rail on 18 in. Conc. Parapet; Redirection, bus rolled over.
Davis (21)	3080-1	School Bus-51.5 20,270-61.6-15	-	120.0	-	32	CMB Concrete; Bus rolled over.
Davis (21)	3115-1	School Bus-51.5 19,990-60.9-16	-	120.0	-	32	CMB Concrete; Bus rolled over.
Ivey (18)	3825-8	School Bus-50 20,000-57.7-15	-	106.0	-	32	CMB Concrete Parapet; Bus rolled over.
Kimball (10)	RF-26	School Bus-55 23,000-57.1-14.7	-	89.7	-	32	Thrie-Beam Bridge Rail; Bus rolled over.
Kimball (10)	RF-27	Scenicruiser Bus-56 40,000-59.7-17.6	-	No data	-	32	Thrie-Beam Bridge Rail; Bus rolled over.
Davis (21)	8307-1	Scenicruiser Bus-50 40,020-54-16.2	-	150.0	-	32	CMB Concrete; Redirection.

*In Tests 3451-9 and 10 the school bus had a C.G. of 50 in. prior to impact. During impact with the 27 in. high rail, the front axle was knocked out from under the bus and the front end of the bus dropped down 24 in. The C.G. was almost instantly lowered 7 in. down to 43 in. before the rear axle impacted the rail. This unusual behavior had a significant stabilizing influence on the bus.

TABLE 1. SUMMARY OF VEHICLE TEST RESULTS (continued)

Author (Reference)	Test No.	Test Condition Veh.-CG in. Veh. Wt.-Speed-Angle lb-mph-degrees	Max. Avg. 0.05 sec Force		Height of		Barrier and Remarks
			Load Cells kips	Accelerometer kips	Resultant in.	Barrier in.	
Davis (21)	8307-3	Scenicruser Bus-50 40,030-54-14	-	170.0	-	32	CMB Concrete; Redirection.
Buth (16)	4798-12	Scenicruser Bus-56 39,970-59.6-14.5	-	179.9	-	34	Thrie-Beam Median Barrier; Bus rolled over.
Kimball (10)	RF-28	Scenicruser Bus-56 40,000-56.3-14.5	-	164.0	-	38	Thrie-Beam Bridge Rail; Smooth redirection.
Hirsch (5)	230-3	School Bus-50 19,690-54.4-15	-	96.5	-	42	Conc. Parapet & Metal Rail; Smooth redirection.
Noel (7 & 22)	3451-34	School Bus-50 20,030-57.6-15	73.8	82.2**	32.7	42	Concrete Wall; Smooth redirection.
Noel (7 & 22)	3451-35	Intercity Bus-46 32,020-56.9-15.7	211.2	220**	28.4	42	Concrete Wall; Smooth redirection.
Hirsch (5)	230-5	Intercity Bus-46 32,080-61.1-15	-	105.9	-	42	Concrete Parapet & Metal Rail; Smooth redirection, 44 in. rail defl.
Kimball (14)	BR-8	School Bus-53 ± 19,000-60.9-13.9	-	74.1	-	59	Collapsing Ring Bridge Rail
Kimball (14)	BR-11	Intercity Bus-53 ± 40,000-54.2-15.1	-	88.0	-	59	Collapsing Ring Bridge Rail 35 in. permanent defl.
Bronstad (17)	TTR-2	School Bus-53 ± 20,000-55.2-13.7	-	80.0	-	60	Thrie-Beam Bridge Rail; Bus rolled over-rail defl.
Bronstad (17)	TTR-3	School Bus-53 ± 20,000-53.9-15.3	-	70.0	-	60	Thrie-Beam Bridge Rail; Good redirection.
Ivey (20)	3825-17	Ford Truck-58 18,240-60.1-15	-	153.0	-	32	CMB Concrete; Truck rolled over.
Davis (21)	8307-2	Tractor-Trailer Van-60 40,030-53-15	-	110.0	-	32	CMB Concrete; Truck mounted and straddled CMB.
Hirsch (12)	CMB-7	Tractor-Trailer Van-55 48,800-44.7-15	-	143.2	-	32	CMB Concrete Parapet; Smooth redirection.

**Corrected for shifting load.

TABLE 1. SUMMARY OF VEHICLE TEST RESULTS (continued)

Author (Reference)	Test No.	Test Condition Veh.-CG In. Veh. Wt.-Speed-Angle lb-mph-degrees	Max. Avg. 0.05 sec Force		Height of		Barrier and Remarks
			Load Cells kips	Accelerometer kips	Resultant in.	Barrier in.	
Buth (16)	4348-2	Tractor-Trailer Van-78 80,180-52.8-15	-	194.0	-	42	Concrete Parapet CMB Type; Truck rolled over.
Buth (16)	4798-13	Tractor-Trailer Van-65 80,180-52.1-16.5	-	108.5	-	42	Concrete Parapet CMB Type; Redirection.
Hirsch (4)	416-1	Tractor-Trailer Van-66 80,080-48.4-15	-	188.0	-	50	Concrete Parapet CMB Type & Metal Rail; Truck rolled over.
Hirsch (1)	230-6	Tractor-Trailer Van-64 79,770-49.1-15	-	200.5	-	54	Concrete Parapet & Metal Rail; Smooth redirection.
Kimball (14)	BR-14	Tractor-Trailer Van-50 40,000-57.3-15.6	-	117.0	-	59	Collapsing Ring Bridge Rail - 10 ft defl.; Truck rolled over; defec- tive rail.
Hirsch (2)	911-1	Tractor-Trailer Tank-72 80,120-51.4-15	-	188.6	-	90	Concrete Parapet; Smooth redirection.

accordance with current recommended procedures (6). The approximate costs per foot of length shown on Figure 1 would be typical of Texas and are for comparison only. Barriers similar to those shown in Figures 2 and 3 have not yet been built in Texas, and the costs shown are estimates.

The definitions of a bridge rail, longitudinal barrier, median barrier, roadside barrier, traffic barrier, etc., are taken from the GLOSSARY in Reference (23) and presented in Appendix A.

BASIC MOTOR VEHICLE AND LONGITUDINAL BARRIER PROPERTIES TO BE CONSIDERED

Most all current longitudinal barriers (guardrails, bridge rails, and median barriers) are designed only to restrain and redirect passenger cars ranging in weight from 1700 lb to 4500 lb. The recommended strength test (6) is for a 4500 lb car to be redirected at 60 mph and 25° angle impact. Figure 1 shows some basic properties of these cars and two very common and effective longitudinal barriers which can restrain and redirect them. These cars have center of gravities (c.g.'s) ranging from 18 in. to 24 in. above the roadway. The 27 in. high standard guardrail and 32 in. high concrete safety shape are strong enough to redirect the cars and high enough to prevent rollover. These barriers exert a redirecting and stabilizing force on the fenders, tires, and door panels of the impacting car, as shown in the figure. The approximate cost per foot of these traffic barriers is shown for comparison purposes.

Figure 2 shows some basic properties of buses (school and intercity) and two longitudinal barriers which have restrained and redirected them. School buses (66 passenger) generally weigh from 20,000 to 26,000 lb loaded. Intercity buses (45 passenger) generally weigh from 32,000 to 40,000 lb loaded. The center of gravity of these buses ranges from 46 in. to 58 in., with an average of about 52 in. The two minimum height rails which have prevented these buses from rolling over at 60 mph, 15° angle impact (the recommended test 6)) are the two shown with heights of 38 in. and 42 in. The approximate cost per foot of the barrier is shown for comparison purposes.

Traffic barriers 32 in. and 34 in. high have consistently produced rollover with buses at 60 mph and 15° angle of impact. The significant redirection force from these barriers is delivered to the bus through the front and rear tires and axles. The largest impact force reported in Table 1 occurs when the rear tires and axle impact the barrier.

Figure 3 shows some basic properties of van and tank-type trucks and some longitudinal barriers which have restrained and redirected them. These trucks weigh from 25,000 lb empty up to 80,000 lb when fully loaded. The center of gravity (c.g.) of an empty truck can be about 45 in., while a fully loaded truck could have a center of gravity of from 60 in. up to 78 in. Figure 3 shows three distinct locations or heights where a longitudinal barrier can effectively push on a van or tank truck to redirect it. A 42 in. high barrier can push on the 42 in. high tires and axle. For a van-type truck, the floor system from 48 in. to 54 in. high is capable of receiving a significant redirection force. Above this height the van truck generally has a very thin and weak sidewall not capable of receiving much redirection force.

A tank truck can receive a redirection force through the tires up to 42 in. high and then another redirection force at about 84 in. high into the central area of the usually circular tank. A longitudinal barrier element between 42 in. and 78 in. usually has nothing to push against.

The 42 in. high concrete median barrier shown redirected without rollover an 80,000 lb van truck with 65 in. high center of gravity. A similar truck with 78 in. high center of gravity rolled over the 42 in. high barrier (16). All these tests are at the recommended speed (6) of nominally 50 mph and 15° angle impact.

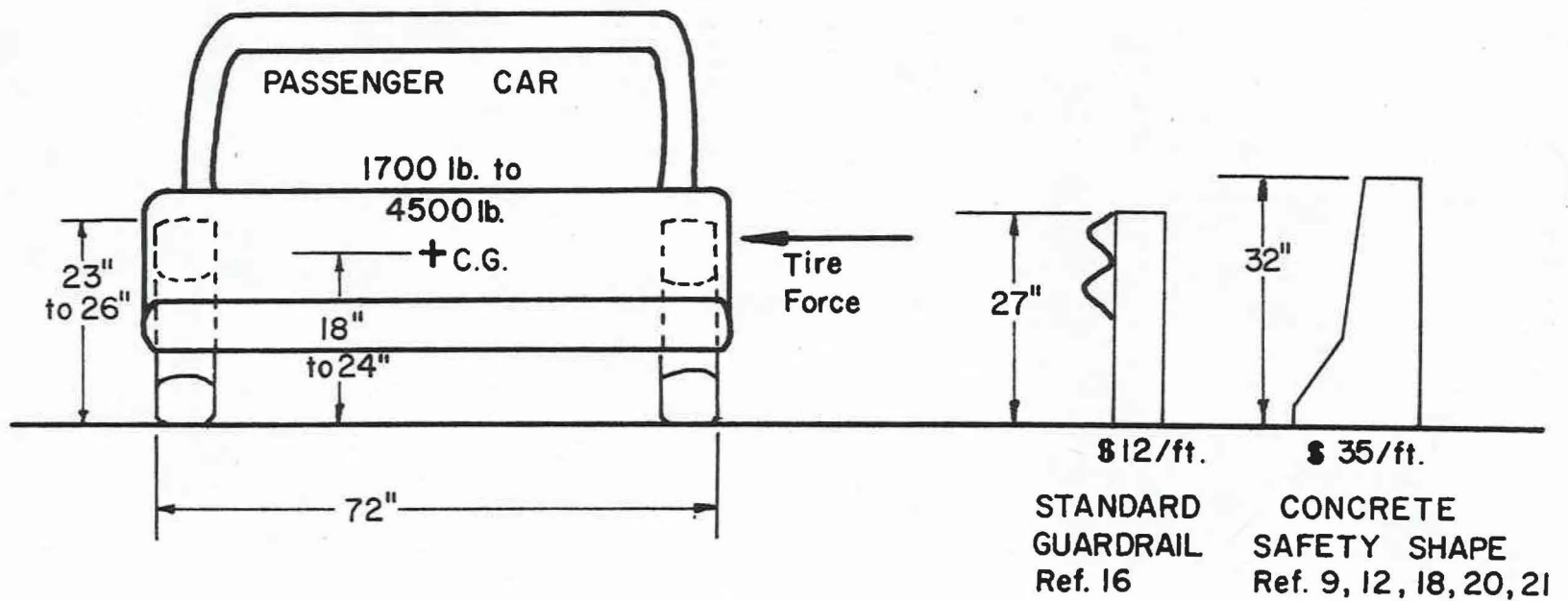

FIGURE 1. BASIC PROPERTIES OF PASSENGER CARS AND EFFECTIVE LONGITUDINAL BARRIERS

INTERCITY BUS
32,000 lb. to 40,000 lb.
9 to 10 ft. high

SCHOOL BUS
20,000 lbs. to 26,000 lbs.

+ c.g.

46"
to 58"

Tire
Force

42"

38"

42"

96"

\$ 45/ft.
Ref. 10

\$ 50/ft.
Ref. 5

BUS RAILS

FIGURE 2. BASIC PROPERTIES OF BUSES AND TWO EFFECTIVE LONGITUDINAL BARRIERS

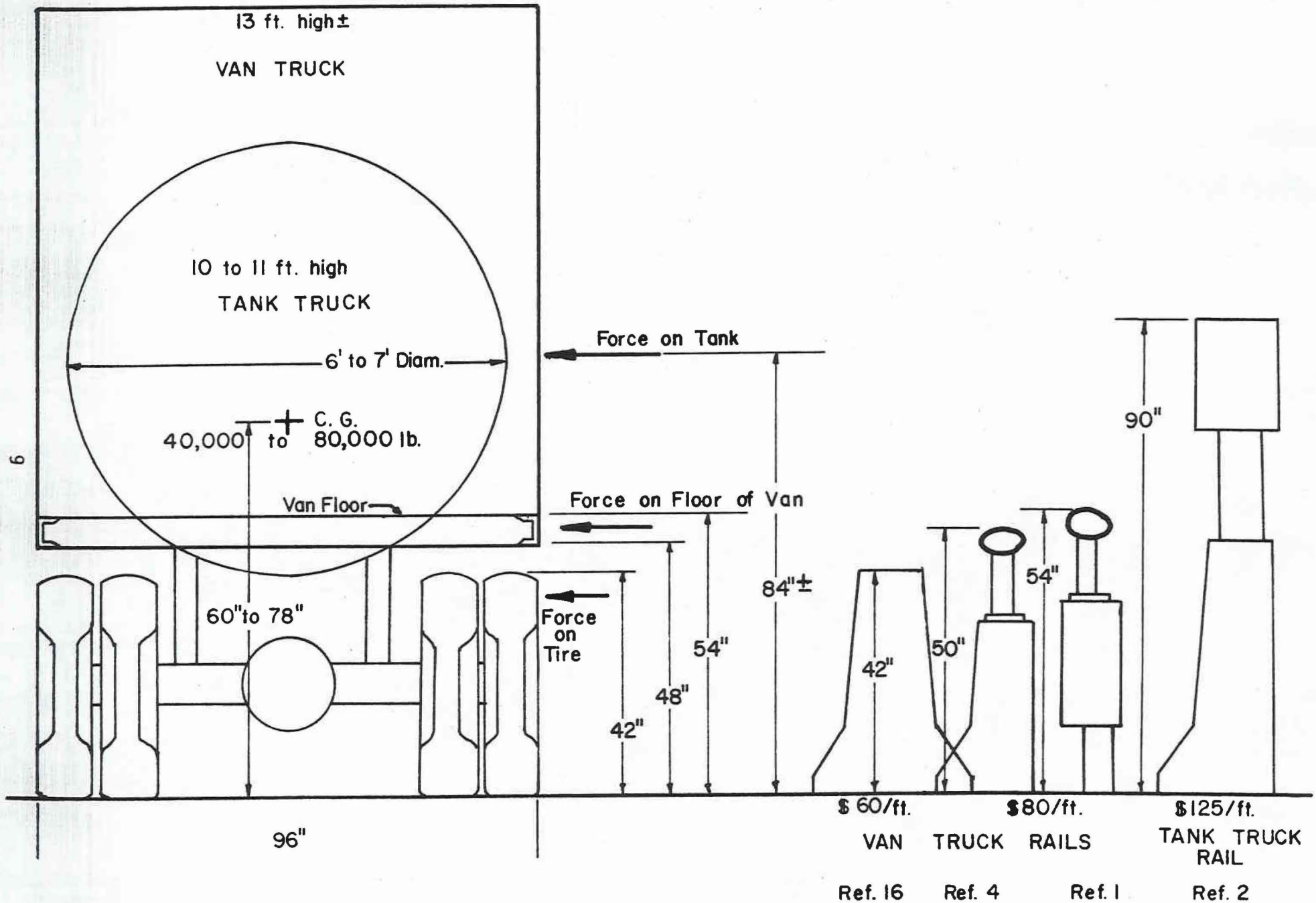

FIGURE 3. BASIC PROPERTIES OF TRACTOR-TRAILER TRUCKS (VAN AND TANK TYPES) AND SOME LONGITUDINAL BARRIERS WHICH HAVE RESTRAINED AND REDIRECTED THEM

The 50 in. high combination barrier (concrete bridge rail with metal rail on top) restrained and redirected an 80,000 lb van truck with 66 in. high center of gravity. The truck was lifted by the safety shape profile and its front bumper impacted the posts supporting the metal rail. This reduced the effectiveness of the metal rail. The truck rolled over on its side. However, it did not go over the bridge rail, and the truck remained on the simulated bridge. This was considered a successful test for a truck. A rollover would not be acceptable for a passenger car or bus.

The 54 in. high combination concrete and steel bridge rail shown smoothly restrained and redirected an 80,00 lb van truck with a 64 in. high center of gravity (no rollover).

STRENGTH REQUIREMENTS OF LONGITUDINAL BARRIERS

A relatively simple method of predicting the impact forces on a longitudinal barrier are the equations presented in NCHRP Report 86 (13).

Figure 4 illustrates a vehicle impacting a longitudinal barrier at an angle θ . From this illustration of the impact event it can be shown (13) that the average lateral vehicle deceleration (G_{lat}) is

$$\text{Avg } G_{lat} = \frac{V_I^2 \sin^2(\theta)}{2g[AL \sin(\theta) - B[1 - \cos(\theta)] + D]} \quad \text{Eq. 1}$$

If the stiffness of the vehicle and barrier could be idealized as a linear spring, the impact force-time curve would be in the shape of a sine curve; then the peak or maximum lateral vehicle deceleration ($\max G_{lat}$) would be

$$\max G_{lat} = \frac{\pi}{2} (\text{avg } G_{lat}) \quad \text{Eq. 2}$$

The lateral impact force (F_{lat}) on the longitudinal barrier would then be equal to the lateral vehicle deceleration times the vehicle weight, thus

$$\text{avg } F_{lat} = (\text{avg } G_{lat})W \quad \text{Eq. 3}$$

and

$$\max F_{lat} = \frac{\pi}{2} (\text{avg } F_{lat}) \quad \text{Eq. 4}$$

One could determine the longitudinal forces on the barrier by multiplying the lateral forces times the coefficient of friction (μ) between the vehicle and barrier. The symbols used are defined as follows:

- L = vehicle length (ft);
- 2B = vehicle width (ft);
- D = lateral displacement of barrier (ft)
assumed as zero for rigid barriers;
- AL = distance from vehicle's front end to center of mass (ft);
- V_I = vehicle impact velocity (fps);
- V_E = vehicle exit velocity (fps);
- θ = vehicle impact angle (deg);
- μ = coefficient of friction between vehicle body and barrier;
- a = vehicle deceleration (ft/sec²);
- g = acceleration due to gravity (ft/sec²);
- m = vehicle mass (lb-sec²/ft); and
- W = vehicle weight (lb).

These equations express the average vehicle decelerations as a function of: (a) type of longitudinal barrier -- rigid or flexible; (b) dimensions of the vehicle; (c) location of the center of mass of the vehicle; (d) impact speed of the vehicle; (e) impact angle of the vehicle; and (f) coefficient of friction between the vehicle body and longitudinal barrier. When computed deceleration values from these equations were compared with full-scale

INSTANT OF VEHICLE - BARRIER
RAILING COLLISION

INSTANT VEHICLE BECOMES
PARALLEL TO UNDEFORMED
BARRIER RAILING

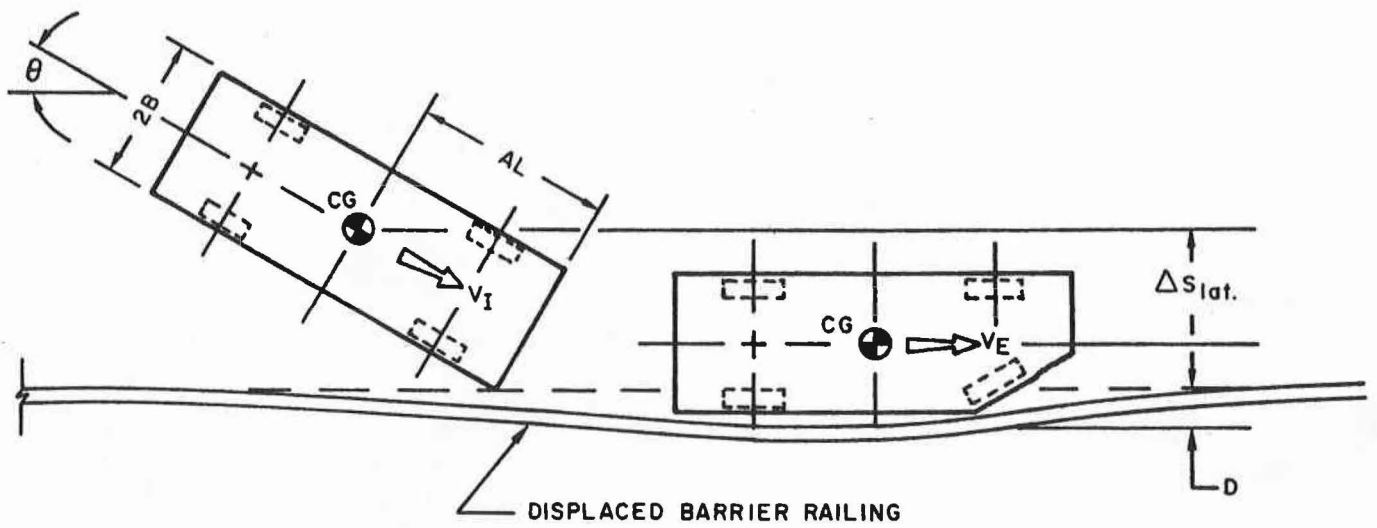

FIGURE 4. MATHEMATICAL MODEL OF VEHICLE-BARRIER RAILING COLLISION
(after NCHRP 86, Ref. 13)

automobile crash test data, it was found that these equations predict the behavior of standard size passenger car vehicles to an accuracy of ± 20 percent. Such a comparison is remarkable when one considers the simplicity of the model and the difficulties involved in acquiring and reducing data obtained from full-scale dynamic tests.

These equations were used to compute the lateral impact forces a vehicle would impose on a rigid longitudinal barrier and plotted on Figure 5. For articulated vehicles like tractor-trailer trucks, only the tractor is considered to impact the barrier. The rear axles of the trailer and the load they are supporting is not considered. Numerous crash tests have shown that the big impact force is delivered by the rear tandem axles of the tractor. The impact force of the front axle of the tractor is smaller. The rear axle of the trailer frequently does not even impact the longitudinal barrier, and if it does, the force has been small.

Table 1 and Figure 5 present some actual measurements (from load cells) of impact forces during crash tests. Table 1 also presents some estimates of impact forces as determined from accelerometers located on the vehicles. These estimates of impact forces from accelerometer readings were made as follows:

1. For the passenger cars, van, school buses, and nonarticulated trucks, the accelerometers were located near the vehicle c.g. The impact forces were obtained by multiplying the maximum average 50 ms acceleration in g's by the total weight of the vehicle.
2. The impact forces for the intercity and scenicruiser buses were obtained as above except for the two tests by Davis (test No. 8307-1 and 3). For those two tests, the accelerometers were located over the rear axles and thus the maximum average 50 ms acceleration in g's was multiplied by the weight on the rear axles only.
3. Impact forces for all the articulated tractor-trailer rigs were obtained from accelerometers located on or near the rear tandem axles of the tractor. The maximum average 50 ms acceleration in g's was multiplied by the weight on the rear tandem axles only to obtain the recorded maximum forces.

When these maximum 50 ms forces from the crash tests with buses and trucks impacting at nominally 60 mph and 15° are compared on Figure 5 with those predicted by Eq. 4, they seem to be about 78% higher. Some reasons for this could be (a) the larger wheel base length of buses and trucks, (b) the payload is a larger percent of the total load and shifts during impact, (c) tractor-trailers are articulated, and (d) these test results are the maximum average 50 ms impact forces whereas the theory is an idealized sinusoidal maximum force occurring during a time period of 300 ms or more. Consequently, the measured 50 ms impact forces are expected to be higher than the theory which computes average impact force over a longer 300 ms time duration.

The value of the theory and Eq. 4 is that it shows some of the significant parameters which affect the impact forces, i.e., impact velocity, impact angle, vehicle length, vehicle width, vehicle weight, deflection of barrier, etc. Figure 5 shows the order of magnitude of the impact forces which a stiff-to-rigid longitudinal barrier must resist.

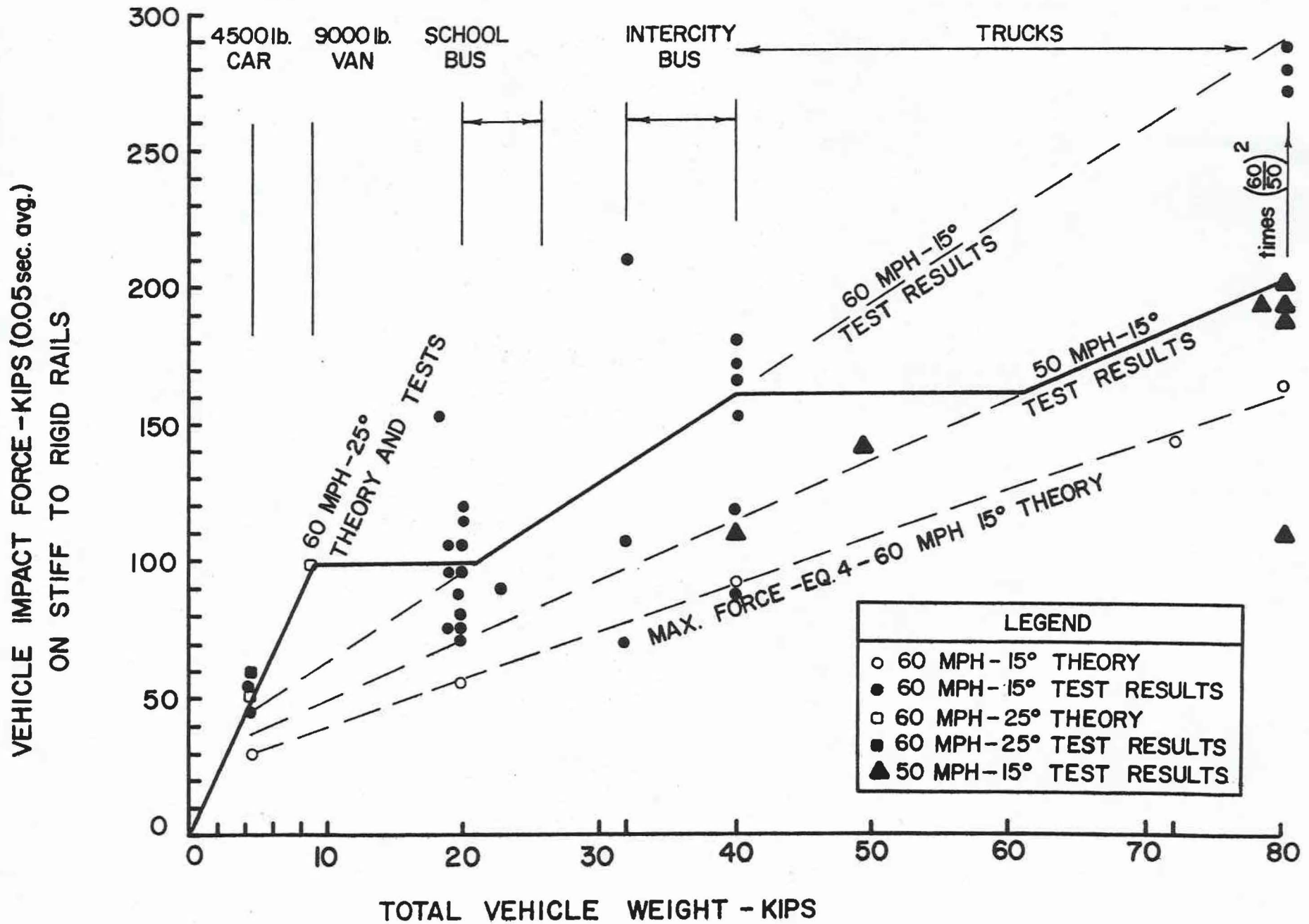

FIGURE 5. COMPARISON OF VEHICLE IMPACT FORCES TO TOTAL VEHICLE WEIGHT - THEORY AND TEST RESULTS - STIFF RAILS

HEIGHT REQUIREMENTS OF LONGITUDINAL BARRIERS

The previous section and Figure 5 presented data on the magnitude of the lateral impact forces imposed on a longitudinal barrier. While a barrier must be strong enough to restrain and redirect a vehicle, it must also be high enough to prevent the vehicle from rolling over it.

Figure 6 shows a rear or front view of a vehicle impacting a longitudinal barrier. The force F_{lat} is the resisting force which would be located at the centroid of the metal rail member or top of a concrete barrier. The height (H) of this resisting force is defined as the effective height of the barrier. For example, the top of a standard 12 in. deep W-beam guardrail is mounted 27 in. high in Texas; however, its effective height (H) would only be 21 in.

In many cases the c.g. height (C) of an impacting vehicle may be much higher than the effective height (H) of the barrier. The vehicle does not necessarily roll over the barrier in this case because a stabilizing moment equal to the weight of the vehicle (W) times one half the width of the vehicle (B/2) is also acting on the vehicle. Equation 5 shown on Figure 6 indicates the approximate effective height required for a barrier to prevent a vehicle from rolling over it. This effective height is a function of the maximum lateral impact deceleration of the vehicle, height of vehicle center of gravity, and width and length of vehicle in this simplified mathematical model. This simplified model does not take into account the roll, pitch and yaw moments of inertia. However, it seems to describe the trends of the test data.

Figure 7 presents a comparison of the required effective height of a longitudinal barrier to the center of gravity height for five selected design vehicles. From Figure 7 it can be seen that to prevent a large passenger car with c.g. from 20 to 24 in. from rolling over the barrier, an effective height of 16 to 21 in. is required. As mentioned previously, the standard guardrail has an effective height of 21 in. Vans and light trucks (pick-up trucks) with c.g. from 30 to 36 in. would require barrier effective heights of from 30 to 34 in. To prevent a school bus with c.g. of 46 to 58 in. from rolling over, the barrier would require an effective height of from 38 to 42 in. An intercity bus would require barriers of similar effective heights. A large van tractor-trailer truck with c.g. of from 60 to 78 in. would require an effective barrier height rail of about 50 to 54 in. A large tank tractor-trailer would require an effective barrier height of about 78 to 90 in.

The preceding suggested barrier heights are only to be used as a general guide. Motor vehicle characteristics vary widely. Operating speeds and possible angles of impact vary widely. Highway engineers should carefully consider the important variables discussed here before selecting a barrier design strength and height.

An example of unusual performance of a 27 in. high bridge rail successfully redirecting a school bus is illustrated by Test Nos. 3451-9 and 10 in Table 1. The school bus had a c.g. of 50 in. prior to impact at 60 mph,

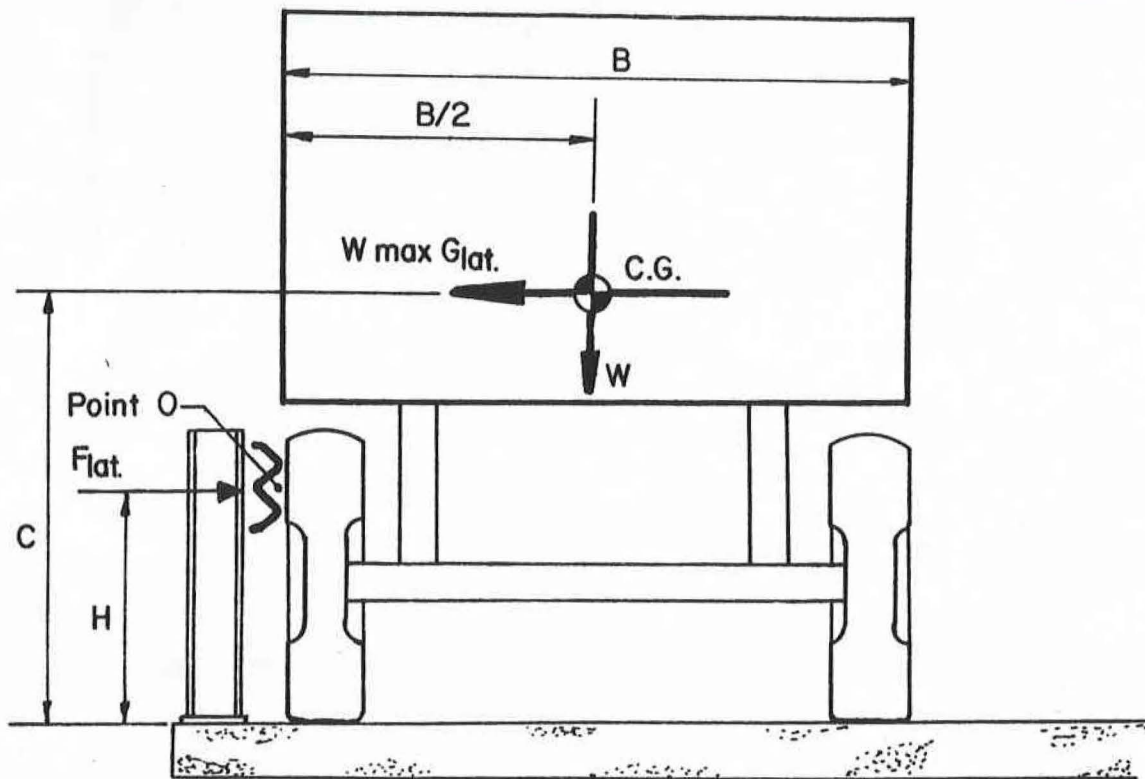

W = weight of vehicle

$\max G_{lat.}$ = max. lateral deceleration of vehicle from Eq. 2

C = height to vehicle c.g., in.

H = effective height of barrier rail, in.

O = center of overturning rotation located at centroid of rail or top of concrete parapet

B = width of vehicle, in.

$F_{lat.}$ = resisting railing force located at effective rail height

$$M_o = W \max G_{lat.} (C - H) - WB/2 = 0$$

$$H = \frac{\max G_{lat.} C - B/2}{\max G_{lat.}} \quad (\text{Eq. 5})$$

FIGURE 6. APPROXIMATE ANALYSIS OF REQUIRED BARRIER EFFECTIVE HEIGHT TO PREVENT VEHICLE FROM ROLLING OVER BARRIER

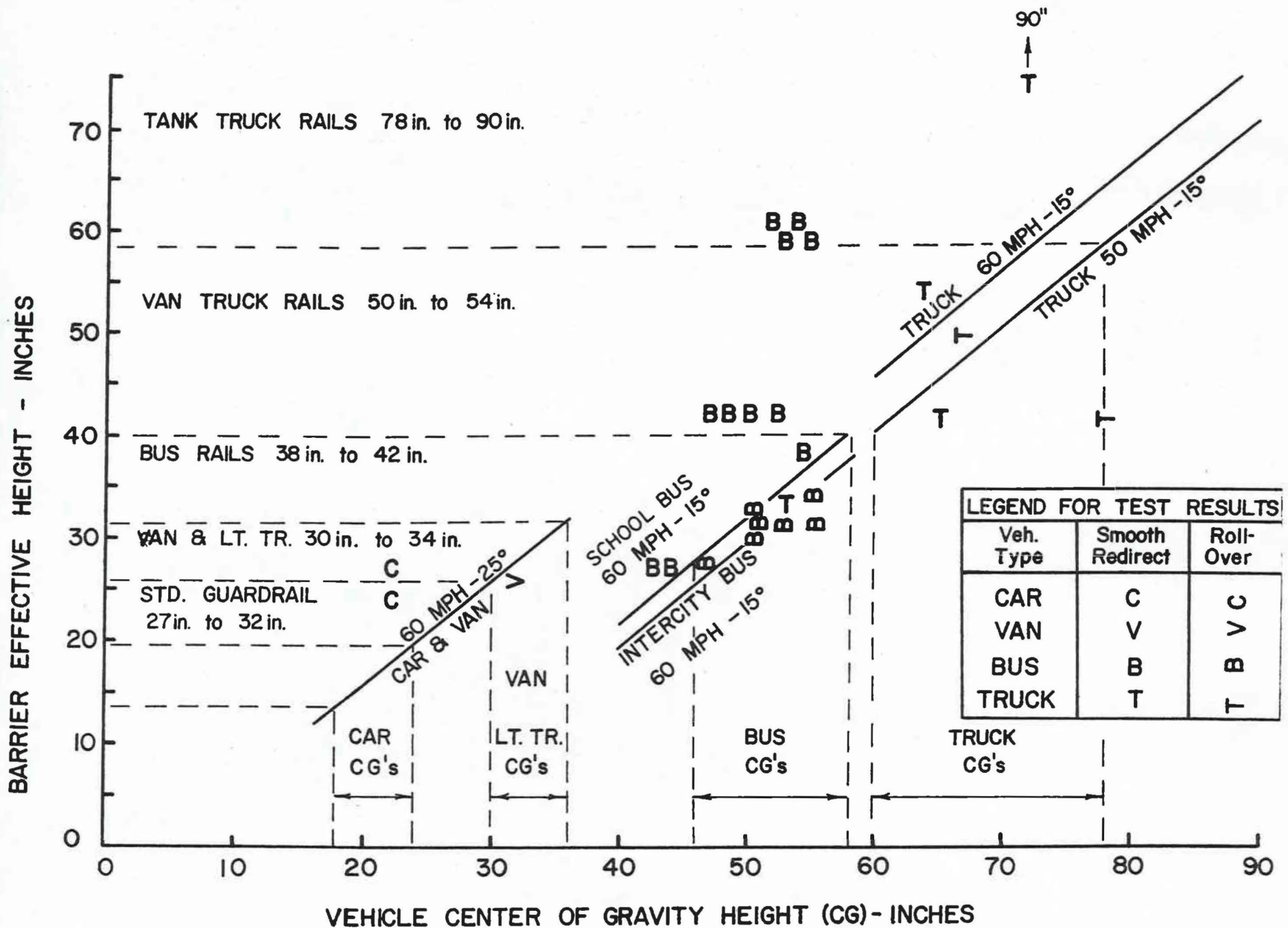

FIGURE 7. COMPARISON OF REQUIRED BARRIER HEIGHT TO VEHICLE CENTER OF GRAVITY—THEORY AND TEST RESULTS

50° angle. During impact with the very strong and rigid bridge rail, the front axle was knocked out from under the bus and the front end of the bus dropped down 24 in. The c.g. was instantly lowered 7 in. down to 43 in. before the rear axle impacted the rail. This unusual behavior had a significant stabilizing influence on the bus. On Figure 7 note the two B's at 27 in. barrier height and 43 in. c.g. height.

SUMMARY AND CONCLUSIONS

The information presented in this paper has shown that longitudinal barriers (guardrails, median barriers, and bridge rails) can be designed and constructed to restrain heavy vehicles such as buses and trucks. Figure 5 indicates the magnitude of the impact forces which these barriers must resist. These forces are for fairly stiff-to-rigid longitudinal barriers. To redirect a 20,000 lb school bus at 60 mph and 15° angle, the barrier should resist about 100,000 lb of force. To redirect a 40,000 lb intercity bus at 60 mph and 15° angle, the barrier should resist about 165,000 lb. To redirect an 80,000 tractor-trailer at 50 mph and 15° angle, the barrier should be capable of resisting about 190,000 lb. Barriers similar to those shown on Figures 2 and 3 have demonstrated this. For precise design details of these barriers, the appropriate references should be consulted.

Figure 7 indicates that to redirect school and intercity buses without rollover, such barriers should be about 38 to 42 in. high. School buses are more vulnerable to rollover than intercity buses. Figure 7 also indicates that van-type trucks need a barrier from 50 to 54 in. high to minimize rollover at 50 mph and 15° angle impact. Tank-type trucks need a barrier from 78 to 90 in. high to prevent rollover at the same speed and angle.

The tests conducted so far indicate that barriers with a vertical face on the traffic side are much better for resisting vehicle rollover. Barriers similar to the 54 in. high combination rail on Figure 2 is an example. On the other hand, the sloping faced concrete safety shape assists the vehicles to roll over. For example, the 42 in. high concrete safety shape on Figure 2 permitted the vehicle to roll 24° before it contacted the top of the barrier. The 50 in. high combination rail on Figure 2 permitted the impacting truck to roll 11° before it contacted the upper steel rail.

REFERENCES

1. Hirsch, T. J. and Arnold, A., "Bridge Rail to Restrain and Redirect 80,000 1b Trucks," Research Report 230-4F, Texas Transportation Institute, Texas A&M University, Nov. 1981.
2. Hirsch, T. J. and Fairbanks, William L., "Bridge Rail to Restrain and Redirect 80,000 1b Tank Trucks," Research Report 911-1F, Texas Transportation Institute, Texas A&M University, Feb. 1984.
3. Hirsch, T. J., "Analytical Evaluation of Texas Bridge Rails to Contain Buses and Trucks," Research Report 230-2, Texas Transportation Institute, Texas A&M University, Aug. 1978.
4. Hirsch, T. J., Fairbanks, W. L., and Buth, C. E., "Concrete Safety Shape with Metal Rail on Top To Redirect 80,000 1b Trucks," Research Report 416-1F, Texas Transportation Institute, Texas A&M University, Dec. 1984.
5. Hirsch, T. J., "Bridge Rail to Restrain and Redirect Buses," Research Report 230-3, Texas Transportation Institute, Texas A&M University, Feb. 1981.
6. Michie, Jarvis D., "Recommended Procedures for the Safety Performance Evaluation of Highway Appurtenances," NCHRP Report 230, Transportation Research Board, National Research Council, Washington, D.C., Mar. 1981.
7. Noel, J. S., Buth, C. E., and Hirsch, T. J., "Loads on Bridge Railings," Transportation Research Record No. 796, 1981.
8. Hirsch, T. J., Panak, J. J., and Buth, C. E., "Tubular W-Beam Bridge Rail," Research Report 230-1, Texas Transportation Institute, Texas A&M University, Oct. 1978.
9. Wiles, E. O., Kimball, C. E., and Bronstad, M. E., "Evaluation of Concrete Safety Shapes by Crash Tests with Heavy Vehicles," Transportation Research Record 631, Transportation Research Board, 1977.
10. Kimball, C. E., Bronstad, M. E., and Michie, J. D., "Heavy-Vehicle Tests of Tubular Thrie-Beam Retrofit Bridge Railing," Transportation Research Record 796, Transportation Research Board, 1981.
11. Arnold, Althea and Hirsch, T. J., "Bridge Deck Designs for Railing Impacts," Research Report 295-1F, Texas Transportation Institute, Texas A&M University, Nov. 1983.
12. Hirsch, T. J. and Post, E. R., "Truck Tests on Texas Concrete Median Barrier," Research Report 146-7, Texas Transportation Institute, Texas A&M University, Dec. 1972.
13. Olson, R. M., Post, E. R., and McFarland, W. F., "Tentative Service Requirements for Bridge Rail Systems," NCHRP Report 86, Highway Research Board, National Research Council, Washington, D.C., 1970.

14. Kimball, C. E., Bronstad, M. E., et al., "Development of a New Collapsing Ring Bridge Rail System," Report No. FHWA-RD-76-39, Federal Highway Administration, Washington, D.C., Jan. 1976.
15. Bloom, J. A., Rudd, T. J., and Labra, J. J., "Establishment of Interim Guidelines for Bridge Rails Required to Contain Heavy Vehicles," Report No. FHWA-RD-75-45, Vol. I, Report No. FHWA-RD-75-46, Vol. II, and Report No. FHWA-RD-75-47, Vol. III, Federal Highway Administration, Washington, D.C., Nov. 1974.
16. Buth, C. E. and Campise, Wanda L., "Performance Limits of Longitudinal Barrier Systems," Vol. 1 Summary Report, FHWA Contract DTFH61-82-C-00051, Texas Transportation Institute, Jan. 1985.
17. Bronstad, M. E., et al., "Development of Retrofit Railing for Through Truss Bridges," Transportation Research Record 942, Transportation Research Board, 1982.
18. Ivey, D. L. and Buth, C. E., "Barriers in Construction Zones," Vol. 1, Appendix A "Individual Test Reports", FHWA Contract No. DOT-FH-11-9458, Texas Transportation Institute, Texas A&M University, Mar. 1984.
19. Standard Specifications for Highway Bridges, Thirteenth Edition, American Association of State Highway and Transportation Officials, Washington, D.C., 1983.
20. Ivey, D. L., Buth, C. E., Love, M. L., and Campise, W. L., "The Response of Atypical Vehicles during Collisions with Concrete Median Barriers," Report on Task 5 of Contract DOT-FH-11-9458, Texas Transportation Institute, Jan. 1985.
21. Davis, S., Baczynski, R., Garn, R., Bjork, T., "Test and Evaluation of Heavy Vehicle Barrier Concepts," Technical Report on Contract DOT-FH-11-9115, Dynamic Science, Inc., July 1981.
22. Buth, C. E., Noel, J. S., Arnold, A. G., and Hirsch, T. J., "Safer Bridge Railing," Vol. 1, 2 and 3, FHWA Contract DOT-FH-11-9181, Texas Transportation Institute, Dec. 1980.
23. Ross, H. E., Jr., Kohutck, T. L., and Pledger, J., "Guide for Selecting, Locating, and Designing Traffic Barriers," Report No. FHWA-RD-76-503, Federal Highway Administration, Washington, D.C., Feb. 1976.

APPENDIX A

GLOSSARY

Area of Concern—An object or roadside condition that warrants shielding by a traffic barrier.

Barrier Warrant—A criterion that identifies an area of concern which should be shielded by a traffic barrier. The criterion may be a function of relative safety, economics, etc., or a combination of factors.

Bridge Rail—A longitudinal barrier whose primary function is to prevent an errant vehicle from going over the side of the bridge structure.

Clear Zone—That roadside border area, starting at the edge of the traveled way, available for safe use by errant vehicles. Establishment of a minimum width clear zone implies that rigid objects and certain other hazards with clearances less than the minimum width should be removed, relocated to an inaccessible position or outside the minimum clear zone, remodeled to make safely traversable or breakaway, or shielded.

Clearance—Lateral distance from edge of traveled way to a roadside object or feature.

Crash Cushion—A traffic barrier used to safely shield fixed objects or other hazards from approximately head-on impacts by errant vehicles. Examples are sand-filled plastic barrels, water-filled tubes, vermiculite concrete cartridges, and steel drums.

Crashworthy Barrier—One that can be impacted by a vehicle at or below the anticipated operating speed of the roadway with low probability of serious injury to the vehicle's occupants.

Experimental Barrier—One that has performed satisfactorily in full-scale crash tests and promises satisfactory in-service performance.

Impact Angle—For a longitudinal barrier, it is the angle between a tangent to the face of the barrier and a tangent to the vehicle's path at impact. For a crash cushion, it is the angle between the axis of symmetry of the crash cushion and a tangent to the vehicle's path at impact.

Length of Need—Total length of a longitudinal barrier, measured with respect to centerline of roadway needed to shield an area of concern.

Longitudinal Barrier—A barrier whose primary functions are to prevent penetration and to safely redirect an errant vehicle away from a roadside or median hazard. The three types of longitudinal barriers are roadside barriers, median barriers, and bridge rails.

Median Barrier—A longitudinal barrier used to prevent an errant vehicle from crossing the portion of a divided highway separating the traveled ways for traffic in opposite directions.

Operating Speed—The highest speed at which reasonably prudent drivers can be expected to operate vehicles on a section of highway under low traffic densities and good weather conditions. This speed may be higher or lower than posted or legislated speed limits or nominal design speeds where align-

ment, surface, roadside development, or other features affect vehicle operation.

Operational Barrier—One that has performed satisfactorily in full-scale crash tests and has demonstrated satisfactory in-service performance.

Research and Development Barrier—One that is in the development stage and has had insufficient full-scale tests and in-service performance to be classified otherwise.

Roadside Barrier—A longitudinal barrier used to shield hazards located within an established minimum width clear zone. It may also be used to shield hazards in extensive areas between the roadways of a divided highway. It may occasionally be used to protect pedestrians or "bystanders" from vehicular traffic.

Roadway—The portion of a highway, including shoulders, for vehicular use.

Shy Distance—Distance from the edge of the traveled way beyond which a roadside object will not be perceived as an immediate hazard by the typical driver, to the extent that he will change his vehicle's placement or speed.

Traffic Barrier—A device used to shield a hazard that is located on the roadside or in the median, or a device used to prevent crossover median accidents. As defined herein, there are four classes of traffic barriers, namely, roadside barriers, median barriers, bridge rails, and crash cushions.

Traveled Way—The portion of the roadway for the movement of vehicles, exclusive of shoulders and auxiliary lanes.