

1. Report No. FHWA/TX-86/402-3F	2. Government Accession No.	3. Recipient's Catalog No.	
4. Title and Subtitle A Study to Develop Warrants for Conversion to One-Way Frontage Roads		5. Report Date June 1988	6. Performing Organization Code
7. Author(s) Carroll J. Messer, Vergil G. stover and J.L. Gattis		8. Performing Organization Report No. Research Report 402-3F	
9. Performing Organization Name and Address Texas Transportation Institute The Texas A&M University System College Station, TX 77843		10. Work Unit No.	11. Contract or Grant No. Study No. 2-8-86-402
12. Sponsoring Agency Name and Address Texas State Dept. of Highways and Public Transportation Transportation Planning Division P.O. Box 5051 Austin, TX 78763		13. Type of Report and Period Covered Final - September 1985 June 1988	
15. Supplementary Notes Research performed in cooperation with DOT, FHWA Research Study Title: Warrants for One-Way Frontage Roads		14. Sponsoring Agency Code	
16. Abstract  This report contains the results of a HP&R research project to develop warrants for conversion of two-way frontage roads in Texas to one-way. A set of volume-based warrants was developed. This report also provides the analyses, documentation and implementation procedures for the warrants.			
17. Key Words Frontage Roads, Warrants, Freeway Design		18. Distribution Statement No restrictions. This document is available to the public through the National Technical Information Service 5285 Port Royal Road Springfield, VA 22161	
19. Security Classif. (of this report) Unclassified	20. Security Classif. (of this page) Unclassified	21. No. of Pages 69	22. Price

## METRIC CONVERSION FACTORS

### Approximate Conversions to Metric Measures

Symbol	When You Know	Multiply by	To Find	Symbol
<b>LENGTH</b>				
in	inches	*2.5	centimeters	cm
ft	feet	30	centimeters	cm
yd	yards	0.9	meters	m
mi	miles	1.6	kilometers	km
<b>AREA</b>				
in <sup>2</sup>	square inches	6.5	square centimeters	cm <sup>2</sup>
ft <sup>2</sup>	square feet	0.09	square meters	m <sup>2</sup>
yd <sup>2</sup>	square yards	0.8	square meters	m <sup>2</sup>
mi <sup>2</sup>	square miles	2.6	square kilometers	km <sup>2</sup>
	acres	0.4	hectares	ha
<b>MASS (weight)</b>				
oz	ounces	28	grams	g
lb	pounds	0.45	kilograms	kg
	short tons (2000 lb)	0.9	tonnes	t
<b>VOLUME</b>				
tsp	teaspoons	5	milliliters	ml
Tbsp	tablespoons	15	milliliters	ml
fl oz	fluid ounces	30	milliliters	ml
c	cups	0.24	liters	l
pt	pints	0.47	liters	l
qt	quarts	0.95	liters	l
gal	gallons	3.8	liters	l
ft <sup>3</sup>	cubic feet	0.03	cubic meters	m <sup>3</sup>
yd <sup>3</sup>	cubic yards	0.76	cubic meters	m <sup>3</sup>
<b>TEMPERATURE (exact)</b>				
°F	Fahrenheit temperature	5/9 (after subtracting 32)	Celsius temperature	°C

### Approximate Conversions from Metric Measures

Symbol	When You Know	Multiply by	To Find	Symbol
<b>LENGTH</b>				
mm	millimeters	0.04	inches	in
cm	centimeters	0.4	inches	in
m	meters	3.3	feet	ft
m	meters	1.1	yards	yd
km	kilometers	0.6	miles	mi
<b>AREA</b>				
cm <sup>2</sup>	square centimeters	0.16	square inches	in <sup>2</sup>
m <sup>2</sup>	square meters	1.2	square yards	yd <sup>2</sup>
km <sup>2</sup>	square kilometers	0.4	square miles	mi <sup>2</sup>
ha	hectares (10,000 m <sup>2</sup> )	2.5	acres	
<b>MASS (weight)</b>				
g	grams	0.035	ounces	oz
kg	kilograms	2.2	pounds	lb
t	tonnes (1000 kg)	1.1	short tons	
<b>VOLUME</b>				
ml	milliliters	0.03	fluid ounces	fl oz
l	liters	2.1	pints	pt
l	liters	1.06	quarts	qt
l	liters	0.26	gallons	gal
m <sup>3</sup>	cubic meters	35	cubic feet	ft <sup>3</sup>
m <sup>3</sup>	cubic meters	1.3	cubic yards	yd <sup>3</sup>
<b>TEMPERATURE (exact)</b>				
°C	Celsius temperature	9/5 (then add 32)	Fahrenheit temperature	°F

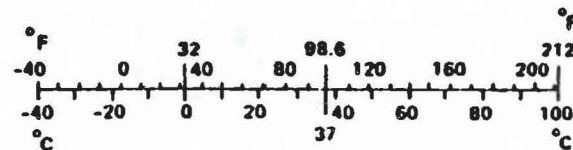

\* 1 in = 2.54 (exactly). For other exact conversions and more detailed tables, see NBS Misc. Publ. 286, Units of Weights and Measures, Price \$2.25, SD Catalog No. C13.10:286.

**A STUDY TO DEVELOP WARRANTS FOR  
CONVERSION TO ONE-WAY FRONTAGE ROADS**

Research Report 402-3F

by

Carroll J. Messer  
Research Engineer

Vergil G. Stover  
Research Engineer

and

J.L. Gattis  
Assistant Research Engineer

Warrants for One-Way Frontage Roads  
Research Study Number 2-8-86-402

Sponsored by  
Texas State Department of Highways and Public Transportation  
In cooperation with the  
U.S. Department of Transportation  
Federal Highway Administration

Texas Transportation Institute  
The Texas A&M University System  
College Station, Texas

June 1988

## **ABSTRACT**

This report contains the results of an HP&R research project to develop warrants for conversion of two-way frontage roads in Texas to one-way. A set of volume-based warrants were developed. This report also provides the analyses, documentation and implementation procedures for the warrants.

**KEY WORDS:** Frontage Roads, Warrants, Freeway Design

## SUMMARY

This report contains the results of a twenty-eight month study to develop numerical warrants for converting two-way frontage roads in Texas to one-way operation. Conversion is a major and continuing issue in Texas for a number of reasons. Urban freeways in Texas were originally built with one-way frontage roads; whereas, rural freeways and most bypasses around isolated towns and smaller cities were provided with two-way operation. As Texas' population continues to grow and its metropolitan areas expand, traffic volumes are increasing on sections of two-way frontage roads that were once located in low-density urban fringe areas but are now urbanizing. Rapidly growing towns are also experiencing similar conditions.

State Department of Highways and Public Transportation (SDHPT) requested Texas Transportation Institute (TTI) to conduct this study to develop warrants, related application guidelines, and procedures for implementation. Recommendations for expediting the conversion process were requested together with supporting background information and documentation.

Several research studies were conducted to obtain the necessary background data. An attitudinal survey was conducted to determine preferences for two-way and one-way operation together with perceived impacts of conversion. Surprisingly strong support for conversion, where warranted, was found to exist with city staff and city council members. On many issues, these groups were found to have preferences similar to those of SDHPT project panel members. The details of this study are documented in Report 402-1.

Operational studies were conducted to obtain the needed traffic performance data. Typical traffic volumes, turning movement patterns and traffic delays were observed. Special entrance and exit ramp delay studies were conducted so that prediction of delays from frontage road volumes could be performed. The results of this study are documented in Report 402-2.

The principal study objectives - the warrants - are contained in this report. Implementation guidelines and supporting materials are also provided. Relevant insight into the complex issues involved in frontage road conversion are highlighted with illustrative case studies from around the state.

## IMPLEMENTATION

This report contains recommended warrants which can be used by SDHPT planning, design, and operations engineers for studying the present or future needs for conversion from two-way to one-way frontage roads. In addition, these same volume-based warrants could be used to determine whether one-way or two-way frontage roads should be provided in a new design. When there is any doubt, one-way frontage roads are recommended in new designs. Also, U-turn lanes should be provided with one-way operation where feasible.

The staging (or implementation sequence) of the freeway mainlanes and frontage roads during construction should be seriously reexamined based on this research study. There appears to be no apparent problem with providing one-way frontage roads as an interim design stage prior to constructing the freeway mainlanes. However, the provision of two-way frontage roads prior to building

the remainder of the freeway, in a developing urban area, may lead to problems when, and if, conversion to one-way operation is proposed due to the following reasons. The initial two-way frontage roads will diminish the pressure on local agencies and developers to construct the desired local street circulation system which will be needed to provide contraflow operations to local developments when one-way flow is implemented if they are not located "on the corners" of the main cross roads at the interchanges. Where stage construction is envisioned, serious consideration should be given to building the mainlanes of the freeway first, then later constructing the appropriate frontage roads, either one-way or two-way. Should two-way be envisioned, every effort should be employed to establish an active and coordinated planning program focused toward providing in the freeway corridor an optimal urban infrastructure for one-way frontage road operations.

Thus, a concerted effort should be implemented at the district level to develop a close rapport with city staff and other officials responsible for planning and designing the related transportation facilities. Formulation of a coordinated program of land-use activities that are optimal with probable future frontage road operations is to be encouraged. Where an existing local business has a major problem with a proposed conversion, innovative approaches may be appropriate for improving contraflow circulation to the site, such as providing construction funds for a local street to provide back-door access to the property if no other solution is apparent.

#### **ACKNOWLEDGEMENTS**

The authors wish to acknowledge those State Department of Highways and Public Transportation personnel who have made special contributions to this research. Mr. Ray Derr (D-18T) and Mr. Harold D. Cooner (D-8) are the SDHPT technical coordinators. In addition to these individuals, a Project Advisory Panel composed of Montie Wade (Dist. 19), Waid Goolsby (Dist. 18), Bob Hodge (D-18), Robert Odstricil (Dist. 17), Herman Gadeke (Dist. 15) and Rick Denny (formerly of D-18T) have provided valuable insight and information to the study. Other participants include: Wallace Ewell (Dist. 2), Eldon McCoy (Dist. 8), Sam Gorman (Dist. 8), Robert Stuard (D-8), Stan Swinton (D-18T), Rick Backlund (D-18T), Carl Wenzel (Dist. 15), and Red Lindsay (FHWA). All participants of the attitudinal survey are gratefully acknowledged.

#### **DISCLAIMER**

The contents of this report reflect the views of the authors who are responsible for the opinions, findings, and conclusions presented herein. The contents do not necessarily reflect the official views or policies of the Federal Highway Administration, or the State Department of Highways and Public Transportation. This report does not constitute a standard, specification, or regulation.

## TABLE OF CONTENTS

	<u>page</u>
Abstract . . . . .	ii
Summary . . . . .	iii
Implementation . . . . .	iii
Acknowledgements . . . . .	iv
Disclaimer . . . . .	iv
List of Figures . . . . .	vi
List of Tables . . . . .	viii
Introduction . . . . .	1
Problem Identification . . . . .	1
Scope of Research . . . . .	6
Previous Research . . . . .	7
Project 402 Studies . . . . .	8
Summary . . . . .	11
Interchange Capacity Studies . . . . .	14
Capacity Analysis . . . . .	14
Summary . . . . .	25
Travel Time Studies . . . . .	26
Introduction . . . . .	26
Study Design . . . . .	26
Results . . . . .	30
Warrants For Conversion . . . . .	42
Scope . . . . .	42
Recommended Warrants . . . . .	42
Corridor Conditions . . . . .	45
Case Studies and Application of Warrants . . . . .	48
Abilene's Experience . . . . .	48
A Residential Development Case . . . . .	49
Studies of Effects on Business . . . . .	49
SH 6 Bypass Case Study . . . . .	49
Application of Warrants . . . . .	54
References . . . . .	59

## LIST OF FIGURES

		<u>page</u>
Figure 1.	Frontage Road Traffic Stoppages and Delays at Ramps . . . .	2
Figure 2.	Observed Separation Distance Between Interchanges For Urban, Town and Rural Development . . . . .	5
Figure 3.	Predicted Delay to Frontage Road Traffic at Ramp Terminals as Related to Volume . . . . .	12
Figure 4.	Average of Four Critical Volume-To-Capacity Ratios as Related to Total Average Daily Traffic Entering the Interchange . . . . .	16
Figure 5.	Average Interchange Delay as Related to Total Average Daily Traffic Entering the Interchange . . . . .	17
Figure 6.	Observed Delay Rate as Related to Sum of Critical Lane Volumes for Stop Controlled Diamond Interchange . . . . .	22
Figure 7.	Observed Delay Rate as Related to Sum of Critical Lane Volumes for Signal Controlled Diamond Interchange . . . . .	23
Figure 8.	Comparison of Predicted Delay Rates Versus Sum of Critical Lane Volumes for Stop and Signal Controlled Interchanges .	24
Figure 9.	Four Types of Trips Evaluated in Travel Time Studies . . .	28
Figure 10.	Added Travel Time (Seconds) Due to Conversion for 5,000-Ft. and 15,000-Ft. Interchange Spacings for Trip Type 1 . . . . .	32
Figure 11.	Added Travel Time (Seconds) Due to Conversion for 15,000-Ft. Interchange Spacing for Trip Type 2 . . . . .	34
Figure 12.	Changes in Travel Time Due to Conversion For Trip Type 3 -- A Local Trip . . . . .	36
Figure 13.	Changes in Travel Time Due to Conversion for Trip Type 4 -- A Tourist Trip . . . . .	39
Figure 14.	Changes in Travel Time Due to Conversion for Trip Type 4 -- A Tourist Who Advance Exits . . . . .	40
Figure 15.	Example of Urban Land Use Which Developed Dependent on Two-Way Frontage Road . . . . .	50
Figure 16.	Failed Business Establishment Located on Two-Way Frontage Road in Navasota . . . . .	51
Figure 17.	Failed Business Establishment Located on Two-Way Frontage Road in Bryan . . . . .	51
Figure 18.	Failed Business Establishment Located on Two-Way Frontage Road in New Braunfels . . . . .	52



Figure 19. Ceased Business Along Two-Way Frontage Road in Ferris . . . 52

Figure 20. Failed Business Establishment Located on Two-Way Frontage Road in Rice . . . . . 53

Figure 21. Location of Appomattox Drive, College Station . . . . . 55

Figure 22. Existing and Proposed Interchanges on State Highway 6, College Station/Bryan . . . . . 57

## LIST OF TABLES

	<u>page</u>
Table 1. Summary of Texas Freeway Frontage Road Operations . . . . .	3
Table 2. Summary of Freeway Frontage Road Operations in Three Urban Districts . . . . .	4
Table 3. Comparison of SDHPT Advisory Panel Responses and Those of Interviewees . . . . .	9
Table 4. Diamond Interchange Types Analyzed For Capacity by PASSER II	14
Table 5. Estimated Capacity of Six Interchange Types in Average Daily Traffic Entering Both Intersections of Interchange . .	15
Table 6. Predicted Total Interchange ADT Based on TTI Study 288 Recommended Safety-Based Frontage Road ADT Volume Warrants .	18
Table 7. Calculated ADT Warranting Traffic From MUTCD Warrant 11 . .	19
Table 8. Calculated ADT Warranting Traffic From MUTCD Warrant 11 for Rural or Higher Speed Conditions (70% of Table 7) . . .	19
Table 9. Characteristics of Bryan Interchanges . . . . .	20
Table 10. Assumed Delays at Ramps and Interchanges . . . . .	30
Table 11. Average Daily Traffic Volume Entering an Interchange That Warrants Conversion of Frontage Roads From Two-Way to One-Way Operation . . . . .	44
Table 12. Application of ADT Conversion Warrants to a Bypass Around Bryan/College Station . . . . .	56

## INTRODUCTION

### PROBLEM IDENTIFICATION

Frontage roads are commonly found on freeways in the State of Texas. This common design is most uncommon on a national scale. The frontage roads were often constructed to either restore access to abutting properties that was taken away when the original highway was upgraded to freeway standards, or were provided in other locations where it was determined that the acquisition of access rights would exceed the cost of frontage road construction.

Frontage roads have many beneficial aspects. Not only do they provide high-quality access to a major traffic facility which promotes development for the economy of Texas, but they also provide much needed alternative capacity to the freeway when traffic demands are high in the freeway corridor or when the freeway loses capacity due to an accident, stalled vehicle or road maintenance activity. Undoubtedly, other states wish they now had frontage roads on their freeways in urban areas with the onslaught of numerous pavement rehabilitation and bridge reconstruction jobs underway nationwide.

Frontage roads can have either one-way or two-way traffic flow on them. Initial design policy decisions subjectively recognized the desirability of having only one-way frontage roads in existing urban areas. Almost all frontage roads are continuous with one-way operations in the large urban centers of Texas and were designed one-way from their beginning in the late 1940's. It was similarly recognized that frontage roads located in rural areas should be of low-cost design standards (like farm-to-market) and that they should be two-way. Two-way operation was the apparent preferred choice in rural locations where crossover interchange spacings were long. This reduced the travel time experienced by local residents and freeway traffic traveling to local destinations. The benefits of one-way and two-way frontage roads in the vast majority of cases are real and apparent.

Operational problems arise for a variety of reasons, particularly with two-way frontage road operations when traffic volumes reach even moderate levels. Erratic maneuvers and safety problems have been identified as related to the complex traffic maneuvers required at the ramp--frontage road junctions (1). In addition, unusual traffic stoppages and delays are experienced on two-way frontage roads as by state law through traffic must yield to oncoming left turning vehicles that are turning onto the freeway entrance ramp. Figure 1 illustrates some of these operational problems observed on the frontage roads at ramps during field studies conducted within this research effort.

### Mileage of Frontage Roads in Texas

A summary of the basic characteristics of the mileage of one-way and two-way frontage roads in Texas will be helpful in dealing with the scope, benefits and potential future conflicts of each type. The mileage of one-way and two-way frontage roads in Texas as of 1981 is presented in Table 1. The table shows that there are 900 miles of freeways in Texas that have one-way frontage roads on both sides of the freeway. For comparison purposes, it is noted

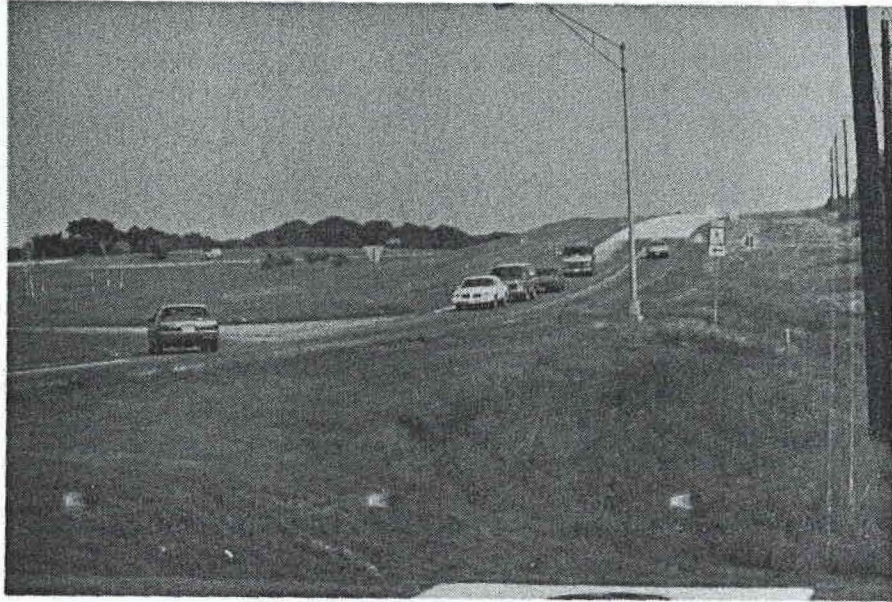

**FRONTAGE ROAD TRAFFIC STOPPAGES AND DELAYS AT RAMPS**

**FIGURE 1**

**TABLE 1**  
**SUMMARY OF TEXAS FREEWAY FRONTAGE ROAD OPERATIONS**

Statewide Classification By Category				
	One-Way		Two-Way	
	<u>one side</u>	<u>both sides</u>	<u>one side</u>	<u>both sides</u>
Miles by Category	220	900	1350	1040
Percent of Total	6%	26%	38%	30%

Statewide Classification By Mileage				
	One-Way		Two-Way	
	<u>one side</u>	<u>both sides</u>	<u>one side</u>	<u>both sides</u>
Miles by Road	220	1800	1350	2080
Percent of Total	4%	33%	25%	38%

that there are 1040 miles of freeways in Texas that have two-way frontage roads on both sides of the freeway. Quite surprisingly, there are 1350 miles of freeways in Texas (38% of the total) that have a two-way frontage road on only one side of the freeway; almost all such mileage is in rural areas of the state.

In general, for those roadways which have frontage roads or access roads, about one-third of the frontage road systems are two-way/both-sides, about one-third are two-way/one-side, about one-quarter are one-way/both-sides, and a small proportion are one-way/one-side. One-way frontage roads compose about one-third of the system by category, and less than 40% by total miles of freeway. Thus, the majority of frontage roads in the state are two-way.

When considering the totals from the three State Department of Highways and Public Transportation (SDHPT) districts with the three largest cities in Texas, a somewhat different breakdown appears. By combining the district totals for District 12 (Houston), District 15 (San Antonio), and District 18 (Dallas), the proportion of one-way frontage roads found in the large urban districts is significantly higher than the statewide average as a whole, as can be seen in Table 2.

Even though these urban districts contain some rural counties along with the urban counties, the impact of the urban counties causes the proportion of the both sides/one-way frontage category to be twice the state average. In these urban districts, the majority of the mileage of frontage roads are one-way. These figures reflect the decision to operate frontage roads in a one-way mode in those areas with higher traffic volumes, such as are found in urban areas.

**TABLE 2**  
**SUMMARY OF FREEWAY FRONTAGE ROAD OPERATIONS IN THREE URBAN DISTRICTS**

	One-Way		Two-Way	
	one side	both sides	one side	both sides
Miles by Category	20	510	70	370
Percent of Total	2%	53%	7%	38%

### Built-in Conflicts

A natural consequence of selecting one-way frontage roads in urban areas and two-way frontage roads in rural areas is the inevitable issue of when two-way operation should be converted to one-way operation as the nature of the land use changes from rural to urban in character either in space or over time. The statistics of Tables 1 and 2 suggest the general scope of the conversion issue. The continual rapid population growth experienced in Texas since 1970, primarily in suburban areas of major cities, is likely to continue and thereby cause rural areas located adjacent to these major cities to be rapidly converted into suburban communities. Traffic problems associated with two-way operations in urban environments will continue to grow until conversion occurs.

### Geometric Design Differences

Circuitry of travel can be a problem for residents living adjacent to any divided highway. A local resident may access the highway from their driveway and have to drive downstream a considerable distance along the divided highway (freeway or not) before being able to turn around at the next crossover, turnaround, intersection, or interchange. Circuitry of travel is not unique just to freeways but also exists with other divided highways. Direct crossing access is always the best circulation option for local users, but this may not be a desirable option to allow and still protect the functionality of the primary highways.

As Figure 2 depicts, one fundamental circulation problem with Texas freeways is that urban freeways have crossovers at interchanges found twice as frequently as in towns like Bryan or New Braunfels, and three times more frequently than found on the average along rural areas of IH 45 and IH 35 south of Dallas, for example. Median (50th-percentile) interchange spacings are about one-half mile in urban areas, one mile in towns, and one and one-half miles in rural areas. The 85-percentile spacings are about one-half mile longer for each category-- urban: one mile; town: one and one-half miles; and rural: two miles, respectively. Natural circuitry of travel is, therefore, much less in urban areas than in rural areas. Fortunately, the volume of rural travel normally is much less, but is growing in urbanizing areas.

Other geometric features of the respective interchange designs should be noted. While no detailed statistics were obtained in this study, it is

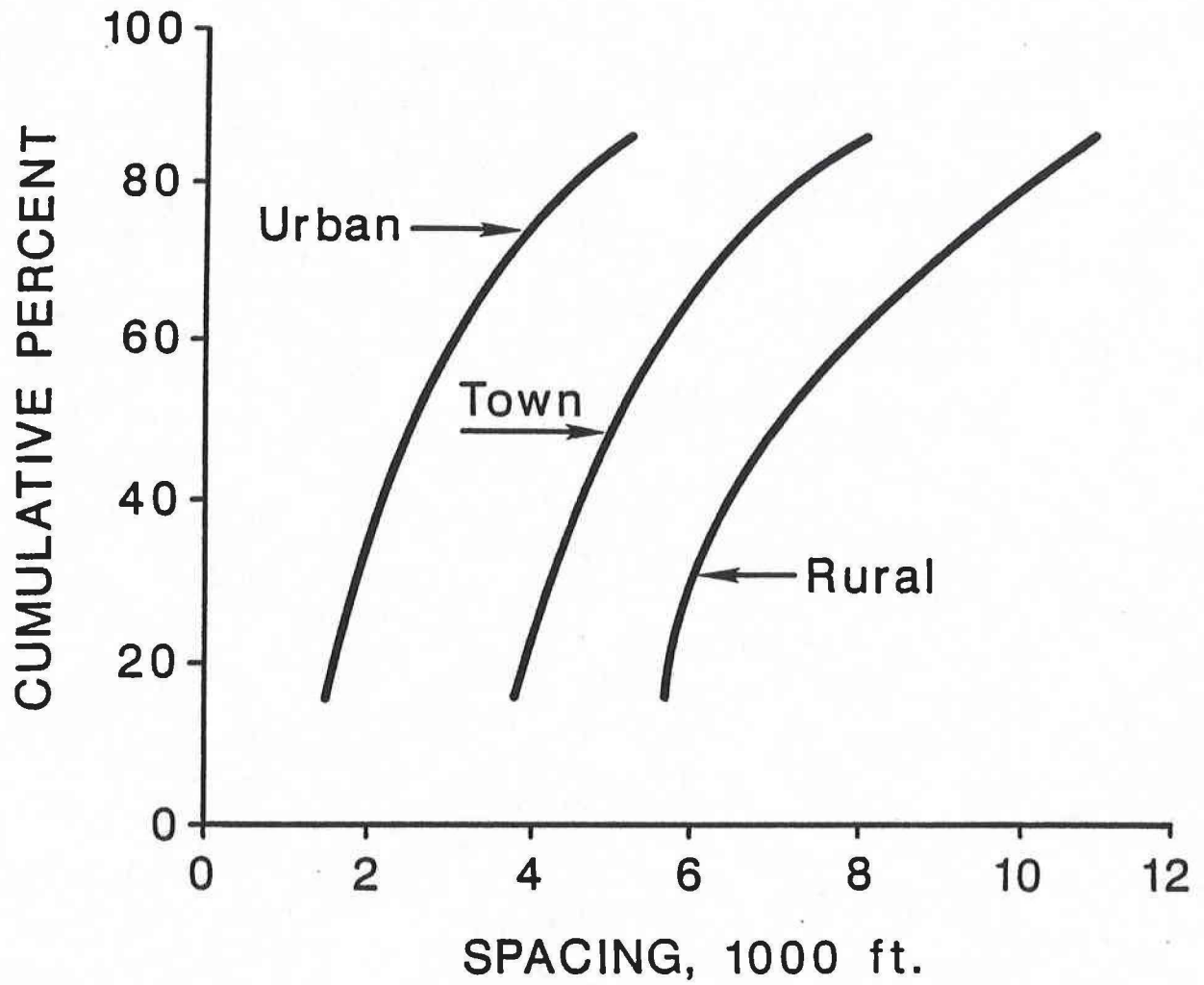

OBSERVED SEPARATION DISTANCE BETWEEN INTERCHANGES  
FOR URBAN, TOWN AND RURAL DEVELOPMENT

FIGURE 2

observed that many urban diamond interchanges with one-way frontage roads have turnaround (U-turn) lanes that save urban freeway users individually nearly a minute of travel time (a half-mile of lost travel at 30 mph); whereas, almost no rural interchange has turnaround lanes, nor can they be economically added since most of these facilities are long crossover bridge structures. This additional feature (U-turn lanes) together with a reasonably close crossover spacing and a good local street circulation system greatly decrease circuitry of travel problems in urban areas.

### Local Street Circulation

As noted, a local street system is a critical factor to the level of complaints related to circuitry of travel. It should be noted that local street systems were already in existence when most urban freeways were built in Texas. As subsequent analyses will show, these existing facilities provided the local circulation in urban areas needed to minimize complaints and other problems arising from circuitry of travel possibilities.

Local street circulation did not exist in the vicinity of freeways either built to function essentially as bypasses around towns and local communities, or constructed as high-speed throughways across rural areas near major cities. As our attitude survey found (2), many local officials from these communities believe that two-way frontage roads provided with these freeways unintentionally became (de facto) the backbone of the local street system near the freeway. The provision of two-way frontage roads thereby diminished the local political or economic initiatives that might have arisen to develop a local street system that would have provided the good local circulation desired for one-way frontage roads. State policies and coordinated planning activities at the district level do not appear to have effectively addressed these conditions in the rapidly urbanizing areas of the state.

### **SCOPE OF RESEARCH**

In an attempt to better define the problems associated with frontage road conversion from two-way to one-way operations and to ultimately recommend effective warranting criteria, the State Department of Highways and Public Transportation requested Texas Transportation Institute to conduct Study 402, "Warrants for One-Way Frontage Roads." The study was a two-year effort and contained the following five research objectives:

1. Identify specific problems encountered by SDHPT in converting from two-way to one-way frontage road operations.
2. Identify the circumstances and the groups making requests for converting existing frontage road flow from one design condition to the other case.
3. Develop guidelines for examining typical frontage road operational situations from the traffic and business community viewpoints.
4. Develop strategies for ameliorating the positions of local interest groups that may conflict with proposed frontage road warrants.



5. Determine the traffic conditions required for converting existing two-way frontage roads to one-way operations to improve the level of service along the facility and to improve safety through accident and conflict reductions.

## **PREVIOUS RESEARCH**

The State Department of Highways and Public Transportation (SDHPT) and Texas Transportation Institute (TTI) have cooperatively performed a series of research projects over the past three decades that have examined several relevant issues. As the following brief literature survey will note, the impacts of basic freeway design on both the traditional motor vehicle user and on adjacent land uses are among the issues which have been addressed.

### **Literature Survey**

Changes in land use and land values as related to the provision of freeway access have been examined. In 1957 Adkins (3) used a parallel band approach (offset distances to the freeway) to determine the effect of a new radial expressway (US 75 - North Central Expressway) on property values in Dallas.

In the late 1960's, Franklin (4) studied the effects of access on right-of-way costs and the determination of special benefits accruing to the property. This TTI study developed several statistical relationships that related cost of right-of-way acquisitions to geographic and access variables. A series of ten case studies was examined to test and evaluate the models. Stover et. al. (5) performed an analysis of the general and specific benefits which accrue to property as a result of highway improvements. Benefits to highway users as well as nonuser groups were investigated. The influences of access and the proximity to freeway interchanges on land values and land use patterns also were summarized.

Buffington (6) et. al. in 1978 conducted a study of non-user impacts of different highway designs as measured by land use and land value changes. A series of over twenty reports were prepared by TTI on this subject.

### **Frontage Road Study**

A study of freeway ramp and frontage road operations was recently completed by Woods (7) at TTI. Operational and safety effects at ramp terminals were emphasized. Data were collected at nine frontage road sites where frontage roads had been converted from two-way to one-way operations. Forty-five ramps were operationally examined. Erratic maneuvers were recorded and accident experience obtained. It was determined that ramp type was not a significant influence on the accident data. Degree of roadside development and frontage road ADT (total of both directions) were the only statistically significant factors determined. Based on the accident analysis and the erratic maneuver data, the following warranting conditions for conversion from two-way to one-way frontage road operations were suggested by Woods:

1. Volume Warrant
  - Rural: 7,500 VPD (total of both frontage roads)
  - Intermediate: 6,000 VPD (total of both frontage roads)
  - Urban: 5,000 VPD (total of both frontage roads)
2. Accident Warrant
  - 20 accidents/mile per year, average of three years
  - 30 accidents/mile, for any one year

None of these studies combined the impacts on traffic with local business impacts to formulate an overall strategy for addressing SDHPT's short-range or long-range needs, both administratively and operationally. Alternative analyses were not suggested nor were significant economic considerations included. Analytic modeling of traffic impacts was very limited in scope. However, the general accident analysis conducted by Woods in Study 288 (7) was as complete as the Texas SDHPT before-after data base permitted. Hence, Woods' volume-based accident warrants were considered adequate for use in this study.

## PROJECT 402 STUDIES

This research effort (402) has already reported on two phases of the study. One phase was conducted to determine the attitudes of interest groups identified as likely being impacted by conversion of frontage roads from two-way to one-way. An attitudinal survey was used as the instrument of evaluation. A second phase of the research effort performed field studies to validate models for estimating travel delays experienced by frontage road traffic at entrance and exit ramps. A summary of the results of these two phases of this study follows.

### Attitude Survey

The attitudinal survey was conducted during 1985-86 by the study team to access the critical issues and concerns of targeted interest groups regarding two-way frontage road operation, one-way frontage road operation, and those specific problems related to conversion from two-way to one-way operations. The details of this survey are published in an earlier study report (2). A brief summary of salient aspects and findings of the survey will follow. These results were used by the study team in formulating the recommendations and guidelines for warranting frontage road conversion and a practical implementation plan expediting the conversion process.

A total of 121 persons were interviewed during the survey. Characteristics of those interviewed included 19 municipal staff (planning and/or engineering), 34 city council members, 24 real estate persons and/or developers, 33 businessmen who were residents of the area and owned or managed a business on a frontage road, and 11 real estate appraisers. Most interviews were conducted in person by a member of the research team. Table 3 presents a statistical summary of the results. Principal survey findings were as follows:

1. Eighty-five percent (85%) of all respondents indicated that they believe one-way frontage roads are safer than two-way frontage roads. This finding must be derived from data given in Table 3.

TABLE 3

COMPARISON OF SDHPT ADVISORY PANEL RESPONSES AND THOSE OF INTERVIEWEES

Statement	SDHPT Advisory Panel %	Interviewees			
		Total %	City Staff %	City Council %	All Others %
1a Favor one-way frontage roads	92	52	90	68	34
2a Agree, businesses upstream/downstream of ramp will be hurt	58	90	68	88	96
2b Agree, businesses between off-ramp and on-ramp will be hurt	8	39	21	38	44
3 Agree, two-way is safer	17	2	0	0	4
4 Agree, one-way has higher capacity	83	55	84	62	43
5 Agree, frontage roads should be one-way when first constructed	100	57	79	71	44
6 Agree, the longer two-way is maintained, the more the opposition to one-way conversion	92	92	100	82	96
7 Agree, build freeways without frontage roads	17	14	31	15	9
8 Agree, two-way frontage roads lead to failure to develop alternate routes	75	56	68	59	52
13 Agree, temporary two-way signs affect land development	83	70	64	68	73
15/18 One-way frontage roads are accepted	58	56	63	67	48

2. The vast majority of all respondents, including businessmen, developers and appraisers, expressed the opinion that the longer frontage roads remain two-way, the more difficult it would be to change them to one-way. Interestingly, city council members tend not to believe this is necessarily the case.
3. SDHPT personnel preferences are most like city planning/engineering staff preferences, and are somewhat similar to city council preferences regarding one-way and two-way operations. All total, 92% of an SDHPT advisory panel of 15 members generally favored one-way frontage roads, 90% of city staff likewise did, and so did 68% of city council members; but, only 34% of the business/real estate interest preferred one-way operations.
4. Business locations just upstream of exit ramps that cater to highway oriented business were expected by business people to be hurt by conversion. Added circuitry of travel following conversion is the obvious reason.
5. Logical investment decisions regarding the type of business to locate at a particular position along the freeway frontage roads are strongly related to accessibility. So is the original cost of the site. Operating profits (and number of customers) are also strongly related to market accessibility. Perceptions of potential reductions in accessibility will generate logical resistances from local businesses to those proposed changes. To assume otherwise would be illogical and insensitive to public perceptions and awareness of economic issues.

### Ramp Delay Study

A study (8) was made to determine the levels of delay incurred by frontage road traffic at intersections with freeway entrance and exit ramps. Four field studies were conducted at sites in medium-sized Texas cities where two moving lanes of frontage road traffic yielded to ramp traffic.

The following frontage road situations were studied:

- Case 1 - one-way frontage road intersection with exit ramp converging movement (used for comparison with two-way frontage road delay);
- Case 2 - two-way frontage road intersection with exit ramp, normal frontage road converging movement;
- Case 3 - two-way frontage road intersection with exit ramp, contraflow frontage road movement; and
- Case 4 - two-way frontage road intersection with entry ramp, contraflow frontage road movement.

Data from the studies was processed in a manner so that individual vehicles could be tracked as they traveled through the area of the ramp--frontage road intersection. Data analysis showed that frontage road and ramp volumes were somewhat correlated; as one increased, so did the other.

Assuming that ramp traffic arrivals could be described by the Poisson process, and from the data knowing the headway acceptance tendencies of each site, that part of the total time period with adequate headways for frontage road vehicles to proceed was found. This value, divided by the headway at which frontage road vehicles would follow each other through the intersection, yielded potential capacity for frontage road traffic at the intersection. This potential capacity is the same as service rate in queueing theory. By modeling the frontage road stream as a queueing system, the queueing delay per frontage road vehicle was found. Recognizing that non-queueing sources of delay, such as time lost while resuming speed after having yielded, are also present, field-measured total delay was regressed against queueing delay to derive models by which total delay could be predicted. Thus, delay to frontage road vehicles was expressed, through a sequence of calculations, as a function of ramp volume, frontage road volume, and ramp design features.

In addition to predicting delays, the fraction of frontage road traffic which was delayed was expressed as a function of the frontage road volume divided by the service rate. Referring to the previous Study 244 (7), which, based on accident experience, proposed warrants to convert two-way frontage roads to one-way when volumes reached certain levels, it was found that these warranting volumes would be accompanied by from 25% to 50% of the frontage road traffic being in potential conflict with the ramp traffic.

Figure 3 shows an example of delays predicted for each of the four study cases with an assumed sample of frontage road and ramp volumes. Typical peak-hour volumes on two-way frontage roads are about 300 vehicles per hour per direction yielding ramp delays ranging from 10-15 seconds per vehicle, depending on the type of ramp and direction of flow. Although any particular site will exhibit its own peculiar combination of ramp and frontage road volumes, this figure serves as an example of how the expected delays will increase as the ramp and frontage road volumes increase.

In addition to studying delays, the report documents certain traffic situations observed while conducting the delay studies.

## SUMMARY

Major determinants for identifying when to convert two-way frontage roads to one-way operation clearly depend on traffic safety and other operational issues. Woods' (7) safety warrants are viewed as being current and applicable. All public interest groups believe that one-way frontage roads are safer than two-way operations. Woods' study documented the operational reasons for this consensus (1,7). The attitude survey (2) found that many business and real estate people will not favor conversion to one-way operations in some cases. Apprehensions about reductions in market value and profits to businesses are plausible reasons for these negative positions. Presently, information is not readily available to identify which businesses will be more severely impacted by conversion nor what can be done to ameliorate these impacts.

It is, therefore, very important that all parties involved be aware of the probable future impacts of a proposed conversion. Principal operational impacts are increases in travel time that might arise to a property due to conversion. On the other hand, further increases in travel time might arise if

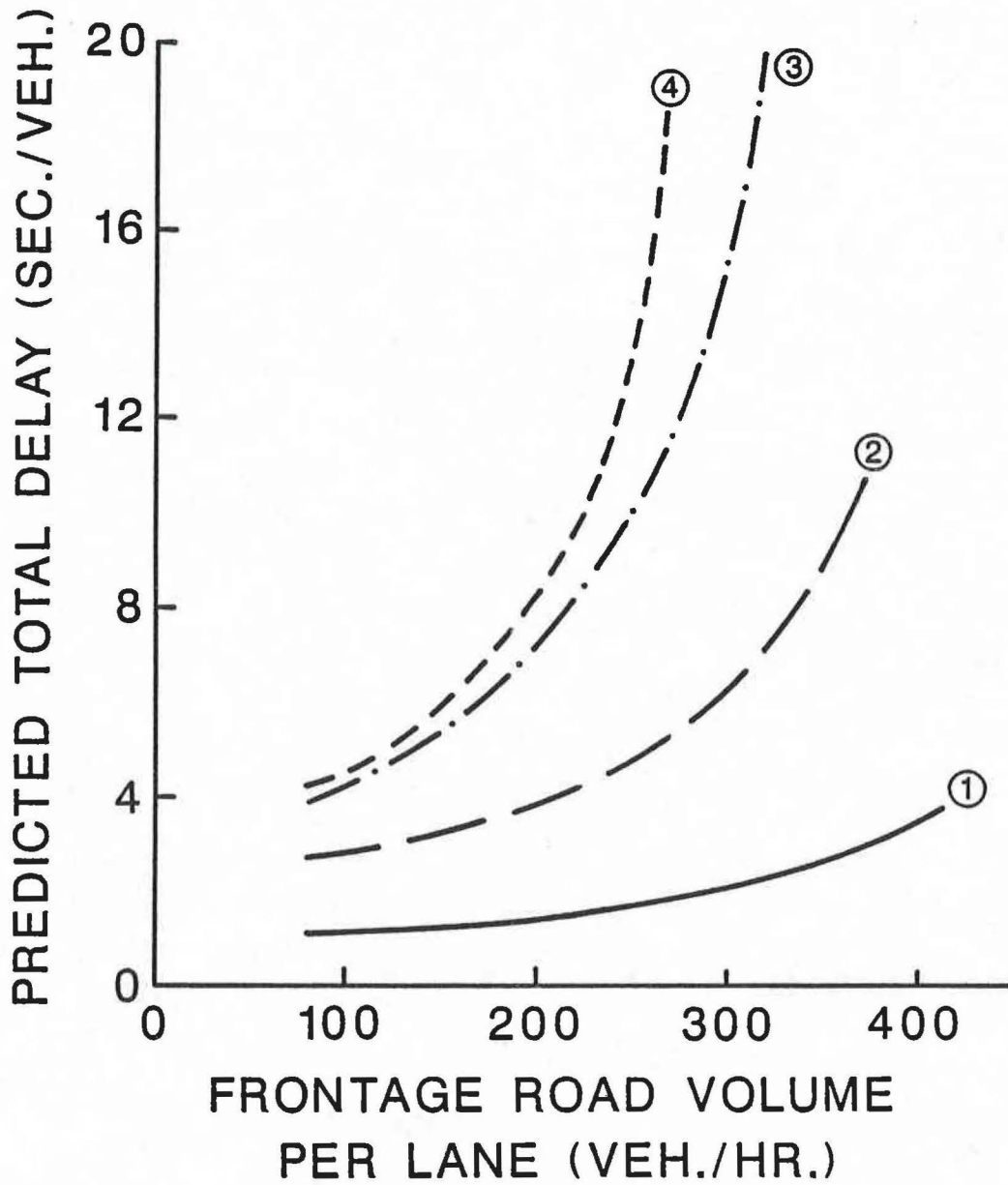

- 1. exit ramp, one-way converging
- 2. exit ramp, two-way converging
- 3. exit ramp, two-way opposing
- 4. entry ramp, two-way opposing

PREDICTED DELAY TO FRONTAGE ROAD TRAFFIC  
AT RAMP TERMINALS AS RELATED TO VOLUME

FIGURE 3

no conversion were implemented due to continually increasing delays that will occur at frontage road ramp terminals and at the diamond interchanges having two-way frontage road operation. Thus, a critical evaluation would compare the travel time expected from a trip origin to a trip destination along frontage roads having two-way operation with the travel time for one-way operation considering the ramp delays previously noted, interchange capacities and delays, and probable traffic patterns. With this information, factual judgments then could be rendered for site specific cases and for more general warranting applications.

In addition to those studies previously described, additional traffic studies were conducted in this research effort to provide the needed operational data. One study, reported in the next section, addresses the diamond interchange capacity and traffic delay issue. A second study, reported in a following section, examines the probable changes in travel time that might be expected to occur for a range of traffic and highway design conditions. These studies, combined with those studies previously reported, form the basis of the one-way conversion warrants and application guidelines that conclude this report.

## INTERCHANGE CAPACITY STUDIES

### CAPACITY ANALYSIS

Studies were conducted to compare the operational effectiveness and capacities of signalized diamond interchanges having either one-way or two-way frontage roads. A signal timing optimization program, PASSER II-84, was used to conduct the capacity analyses and provide traffic signal delay estimations.

Input traffic volume data to the analysis included the following items. All traffic demands were derived from a base cross road average daily traffic (ADT) value. Then, the frontage road located closer to the central business district was assumed to have an ADT that is 60 percent of the cross road. The far-side (other) frontage road was assumed to have an ADT that is 50 percent of the cross road ADT. Thus, the sum of both frontage road ADT's was 1.1 times the cross road ADT. These distributions were derived from field study data (8) and are presumed to be representative of typical conditions. Hourly turning movement volumes were derived from the ADT estimates using an assumed K-factor of 0.084 (from SDHPT's Traffic Engineering Procedures Manual) and peak-hour factor of 0.90 together with turning movement percentages and directional distribution factors developed from the project's volume count study. Additionally, 5 percent heavy vehicles (trucks) with a PCE of 1.5 was assumed based on the 1985 Highway Capacity Manual. (9)

### PASSER II Results

PASSER II was used to develop optimal signal timing plans for progressively increasing average daily traffic (ADT) demands. A series of six geometric designs of diamond interchanges was analyzed. Three were types found on two-way frontage roads and three were for one-way frontage roads. The diamond interchange types shown in Table 4 were studied:

TABLE 4

DIAMOND INTERCHANGE TYPES ANALYZED FOR CAPACITY BY PASSER II

Interchange Report Code	Frontage Roads				Cross Road		
	Two Way	One Way	Basic Lanes	LT Lanes	UT Lanes	Basic Lanes	LT Lanes
2A	Y	-	2	N	-	2	Y
2B	Y	-	2	Y	-	2	Y
2C	Y	-	2	Y	-	4	Y
1A	-	Y	2	N	N	2	Y
1B	-	Y	3	N	N	4	Y
1C	-	Y	3	N	Y	4	Y

Performance results were calculated using PASSER II for volume-to-signal-phase capacity ratios and average stopped delays in seconds per vehicle using the interchange. These results were found for increasing levels of total daily traffic entering both intersections of the interchange in ADT.



Figure 4 presents the volume-to-capacity ratios developed for Cases 2-A, 2-C and 1-C. Cases 2-A and 2-C have two-way frontage roads; 2-A has a two-lane cross road and 2-C has a four-lane cross road as can be determined from Table 4. Case 1-C has one-way frontage roads with turnaround (U-turn) lanes.

Average stopped delays were calculated for the interchanges using PASSER II. Results for the three previous cases are shown in Figure 5. Levels of service based on the 1985 HCM are also noted along the delay scale for comparative purposes. Note that a v/c ratio of about 80 percent is about the maximum that can be tolerated without the delay rapidly escalating to undesirable levels beyond Level of Service C. Thus, an existing v/c ratio of 0.80 is assumed to represent the "service capacity" of a diamond interchange.

These examinations and subsequent decisions should reflect real-world traffic conditions. The analysis so far has examined only perfectly known data together with optimally timed traffic signals. Neither is likely to be the case in practice. An efficiency factor of 80 percent is assumed to convert previous "service capacity" results from an ideal data base and optimal signal timing analysis to real-world traffic conditions. Thus, a "practical capacity" of a diamond interchange would be 80 percent of the service capacity developed from the previously described PASSER II analysis given in Figures 4 and 5.

Table 5 presents estimates of the "practical capacities" for the six types of diamond interchanges studied. ADT (average daily traffic) capacities are provided for the cross road, total for both frontage roads, and the sum total of all traffic entering both intersections from the cross road and both frontage roads. ADT's are totals of both directions of flow that are entering the interchange, including turning movement volumes for the two interior approaches within the interchange. All ADT's are expressed in equivalent two-way frontage road ADT volumes before conversion from two-way to one-way. A K-factor of 0.084 was assumed.

**TABLE 5**  
**ESTIMATED CAPACITY OF SIX INTERCHANGE TYPES IN AVERAGE DAILY TRAFFIC**  
**ENTERING BOTH INTERSECTIONS OF INTERCHANGE**

Interchange Report Code	Service Capacity			Practical Capacity		
	Cross Road	Frontage Roads	Total Entering	Cross Road	Frontage Roads	Total Entering
2A	16,100	8,100	24,200	12,800	6,600	19,400
2B	22,800	11,600	34,400	18,200	9,300	27,500
2C	28,700	14,600	43,300	22,900	11,700	34,600
1A	25,000	12,700	37,700	20,100	10,100	30,200
1B	35,100	17,900	53,000	28,100	14,300	42,400
1C	41,000	20,900	61,900	32,800	16,700	49,500

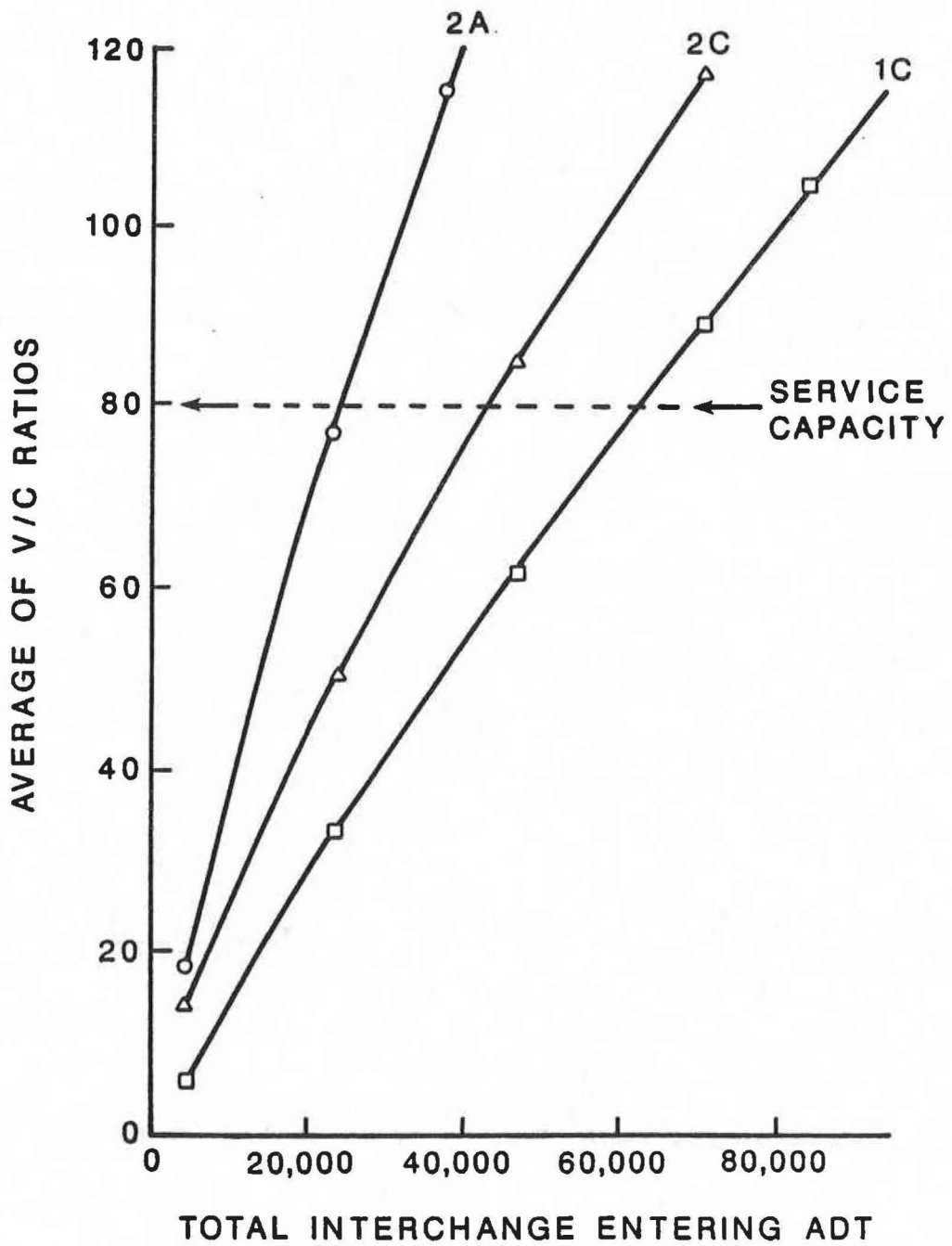

AVERAGE OF FOUR CRITICAL VOLUME-TO-CAPACITY RATIOS AS RELATED TO TOTAL AVERAGE DAILY TRAFFIC ENTERING THE INTERCHANGE

FIGURE 4

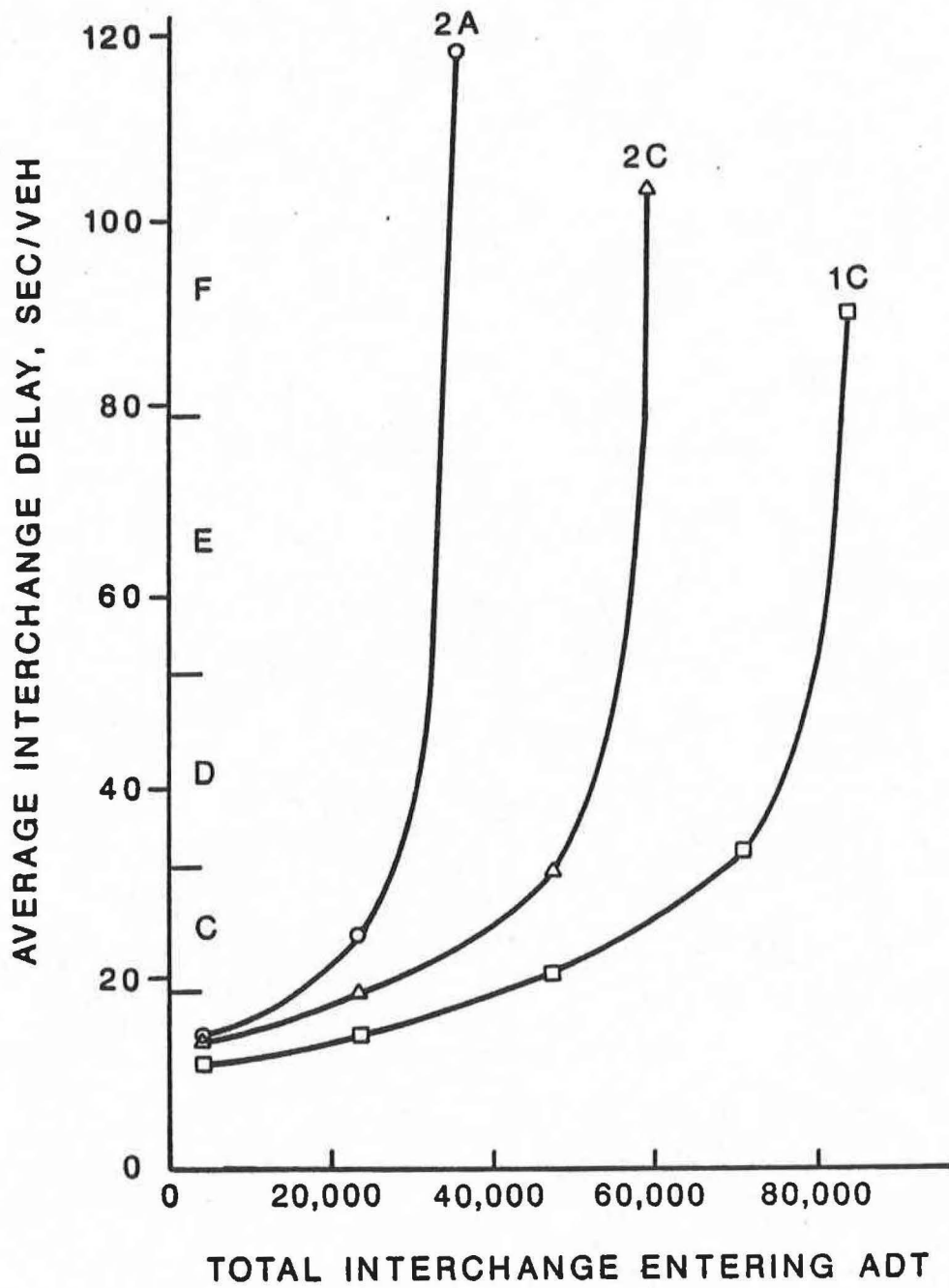

AVERAGE INTERCHANGE DELAY AS RELATED TO  
 TOTAL AVERAGE DAILY TRAFFIC ENTERING THE INTERCHANGE

FIGURE 5

Some comparisons of the capacity increase that may be achieved by converting from two-way to one-way operations on the frontage roads can be obtained from Table 5. Interchange Codes 2A and 1A are basically the same size interchange except for conversion to one-way operations. Both have two-lane, two-way cross roads with left turn lanes. Frontage roads are two lanes without turn lanes. This case is commonly found in developing suburban environs in Texas. The sum total Practical Capacity for 2A is 19,400 ADT; whereas, the sum total ADT for 1A is 30,200. This represents a 55 percent increase in capacity. Increases in capacity for larger interchanges are also noted. A 23 percent increase in practical capacity occurs when 2C (a four-lane cross road) is converted to 1B. But if U-turn (turnaround) lanes are added to the diamond interchange (usually desirable only with one-way frontage roads), then the capacity increase climbs 43 percent to 49,500 for Code 1C.

### TTI Study 288 Volume Warrants

TTI previously studied the operational and safety effectiveness of one-way and two-way frontage roads, and the expected benefits of conversion from two-way to one-way operations (1, 7). Maximum two-way frontage road volume levels were identified above which safety of traffic operations along the frontage roads would likely be seriously compromised. These frontage road volumes are representative of traffic flows between the interchanges. In particular, the suggested frontage road volume warrant was defined as given in Table 6. Also presented in the table are derived total interchange ADT volumes based on typical traffic patterns observed in the present study (402).

TABLE 6

PREDICTED TOTAL INTERCHANGE ADT BASED ON TTI STUDY 288 RECOMMENDED SAFETY-BASED FRONTAGE ROAD ADT VOLUME WARRANTS

Area Type	ADT Volume Warrant Total of Both Frontage Roads	Approximate Total Interchange ADT
Rural	7,500	37,500
Intermediate	6,000	30,000
Urban	5,000	25,000

Examination of the service capacity values given in Table 5 for the two-way frontage road Cases 2A, 2B, 2C reveals that they are near the TTI recommended safety warrant volumes previously developed, as depicted in Table 6. This similarity is a fortunate circumstance. Consider the following two examples for interchanges commonly found in suburban conditions. Code 2A (a two-lane cross road with left-turn lanes intersecting two-lane, two-way frontage roads) has an estimated service capacity of 24,200 ADT; whereas, a larger interchange denoted as Code 2C (a four-lane cross road with left-turn lanes intersecting two-lane, two-way frontage roads with left turn lanes) has an estimated service capacity of 43,300 ADT. The range of service capacities is about the same as the range of recommended TTI volume warrant levels. The TTI safety warrant volumes, however, did not reflect either the capacity of interchanges or cross street volumes since this study focused primarily on the safety aspects of on-ramp and off-ramp traffic operations.

## MUTCD Signal Warrants

The Manual on Uniform Traffic Control Devices now has eleven warranting conditions for the installation of a traffic signal when lesser levels of traffic control have not proven effective (10). Warrant 11 is the new peak-hour volume warrant. The peak-hour volume warrant was used to estimate ADT traffic demands that would warrant the installation of a traffic signal (at the busiest intersection) for the typical turning movement pattern found for two-way frontage roads. Table 7 presents these calculated ADT warrant results for a peak-hour factor, K, of 0.084.

TABLE 7

### CALCULATED ADT WARRANTING TRAFFIC FROM MUTCD WARRANT 11

Two-Way Interchange Type	Two-Way Interchange Code	Average Daily Traffic*		
		Cross Street	Frontage Roads	Sum Total
1 by 1	2A+	18,600	9,400	28,000
2 by 1	2C+	21,600	11,000	32,600
2 by 2	2C	23,900	12,100	36,000

\* Assumes no population or speed reduction to 70% of basic warrant value.

+ Possibly in either class, depending on definition of left turn lane.

Results similar to those presented in Table 7 were obtained using Warrant 1, the 8-th highest hour volume warrant. This result was obtained from hourly turning movement count data reported earlier. An 8-th hour "K Factor" of 0.06 was obtained to convert 8-th hour turning movements to average daily traffic.

Table 8 was developed from MUTCD Warrant 11 and Table 7 by assuming the 70% reduction factor (a 30% net reduction) applied due to the intersection location having either (1) a population in the vicinity of 10,000 or less, or (2) an approach speed on the major street of greater than 40 mph.

TABLE 8

### CALCULATED ADT WARRANTING TRAFFIC FROM MUTCD WARRANT 11 FOR RURAL OR HIGHER SPEED CONDITIONS (70% OF TABLE 7)

Two-Way Interchange Type	Two-Way Interchange Code	Average Daily Traffic*		
		Cross Street	Frontage Roads	Sum Total
1 by 1	2A+	13,000	6,600	19,600
2 by 1	2C+	15,100	7,700	22,800
2 by 2	2C	16,700	8,500	25,200

\* Assumes population reduction to 70% of basic warrant value of Table 7.

+ Possibly in either class, depending on definition of left turn lane.

Complications arise with the interpretation and applications of the signal warrants as applied to two-way frontage roads. Table 5 revealed that the practical capacity of a signalized diamond interchange of a two-lane cross street with two-way frontage roads (Code 2A) is 19,400 ADT, and certainly not more than the 24,200 ADT service capacity. On the other hand, installation of a traffic signal (Table 7) is not warranted until the traffic demand on the interchange reaches about 28,000 ADT. Although not quite as dramatic, similar results are observed for larger interchanges. One would have expected the conversion from stop sign to traffic signal control to occur significantly before the service capacity of the signal is attained. This finding leads one to question the validity of applying the basic signal warrants (Warrant 1 and 11) to intersections having two-way frontage roads. Traffic conditions at these intersections apparently are not typical of those found along arterial streets. From a capacity viewpoint, this anomaly may be due to the fact that left turning traffic at the intersections of diamond interchanges is often 3-to-5 times larger than normally found at arterial intersections. This issue was further examined with two additional field studies conducted in Bryan.

**Bryan Study**

Two diamond interchanges were studied along the East Bypass (TX 6) in Bryan during the last week of April, 1987. Turning movement volumes and stopped-vehicle queue counts (delay) were observed. Volume counts were tallied each 15 minutes and queue counts by movement were manually recorded each 15 seconds. Volume counting covered the period 7 AM - 7 PM; whereas, queue counts were made from 7-8 AM, 9-10 AM, 3-4 PM, and 5-6 PM. Volume-and-delay studies were conducted for two consecutive weekdays at each interchange.

The Bryan Study provides desired field validation of the previous traffic simulation results using PASSER II and interpretations of the subsequent analyses given in Tables 5-8. The East Bypass is a four-lane freeway with two-way frontage roads. The following table (Table 9) summarizes the site characteristics of the two interchanges studied.

**TABLE 9**  
**CHARACTERISTICS OF BRYAN INTERCHANGES**

Diamond Interchange Characteristics	Interchange Name	
	Tabor Rd. F.M. 974	Boonville Rd. S.H. 158
Frontage Roads	Two-Way	Two-Way
Signalized	No	Yes
Total ADT <sup>a</sup>	18,100	27,300
Type	2A <sup>b</sup>	2A <sup>b</sup>
Total ADT <sup>a,b</sup>	17,200	23,500

a Estimated from study and 1985 data.  
b Discounted for free right-turn lane(s).

The two sites were located close to each other. Both had similar traffic and geometric characteristics. It is important to note that Boonville Road is signalized and Tabor Road is not. However, the traffic volume on Tabor Road was known to be relatively heavy as indicated by prior 1985 traffic data and the fact that one of the two intersections there (the CBD-side) has all-way stop control as compared to two-way stop control on the other side.

The results of the Bryan Study strongly support, if not validate, the ADT criteria provided in Tables 5 and 8, but not Table 7 - the basic signal warrant level. Tabor Road (unsignalized) has an ADT of 17,200 - 18,100, which is slightly less than 19,400 (for 2A in Table 5) and 19,600 (1 by 1 in Table 8), but far below the 28,000 ADT warrant given in Table 7. On the other hand, Boonville Road (signalized) has an ADT of 23,500 - 27,300 which is above 19,400 (Table 5) and 19,600 (Table 8), but still below the 28,000 shown in Table 7.

Continued examination of the volume-delay data revealed further useful corroborative information. Figure 6 is a plot of the number of vehicles delayed per unit time versus the sum of critical lane volumes at the stop-controlled interchange (Tabor Road). All demand volumes at Tabor Road are less than 1100. A small cluster of peak-hour flows occurs around 900 and averages about 950. Figure 7 is a similar plot for the signal-controlled interchange (Boonville Road). Notice that over half of the demand volumes are greater than 900. Figure 8 is an overlay plot of Figures 6 and 7. Observe that signal control at Boonville Road performed better than stop control at Tabor Road once the volume level exceeds about 650. While this is not exactly a clean before-after study, clearly the signalized interchange, which had only a basic pretimed signal system, outperformed the stopped-controlled interchange by a significant margin once the critical volume level exceeded 800.

These findings can be applied to the signal warrant issue of Tables 7 and 8 as applied to diamond interchanges located on two-way frontage roads. It is evident that the volume levels given by Table 8 are far superior to those in Table 7 for warranting signalization on two-way frontage roads, regardless of rural or urban conditions. The reason is probably due to the excessive left turning that occurs at diamond interchanges on two-way frontage roads due to the interchanging and access-oriented traffic patterns that predominate. Left turning percentages for some critical movements at Tabor Road averaged 47% on one intersection and 58% on the other. At Boonville, the percentages are 60% and 79%. These values are nowhere close to the more typical 10-15% left turning percentages found at most intersections along arterial streets for which the MUTCD warrants are based.

If it is assumed that Tabor Road is exactly at the signal warranting volume threshold (ADT = 18,100) during the peak hour, having an average peak-hour volume of 950 with a warrant level of 800 based on Figure 8, then the resultant ADT signal warrant level would be  $(800/950) * 18,100 = 15,242$ . The percentage reduction from the unadjusted value given in Table 7 for a 1 by 1 interchange (28,000) is 55%, somewhat lower than the 70% reduction factor for "rural or high-speed conditions."

These results strongly indicate that the basic MUTCD volume warranting levels for signals (using Table 7) applied to diamond interchanges having two-way frontage roads are too high. As a minimum, the 70% reduction factor should automatically be applied anytime two-way frontage roads exists. These results suggest that even a 60% reduction factor would be reasonable.

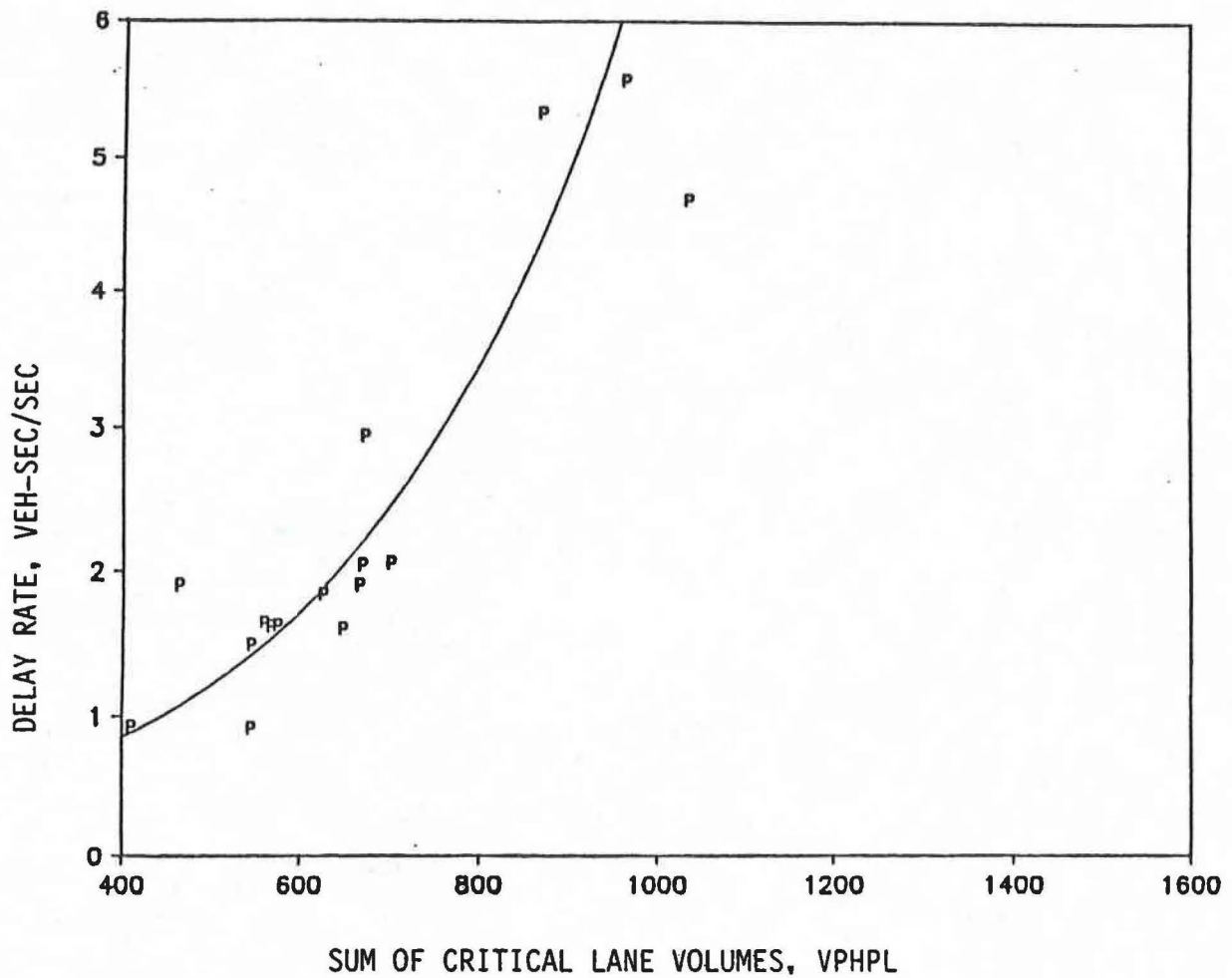

OBSERVED DELAY RATE AS RELATED TO SUM OF CRITICAL LANE VOLUMES FOR STOP CONTROLLED DIAMOND INTERCHANGE

FIGURE 6



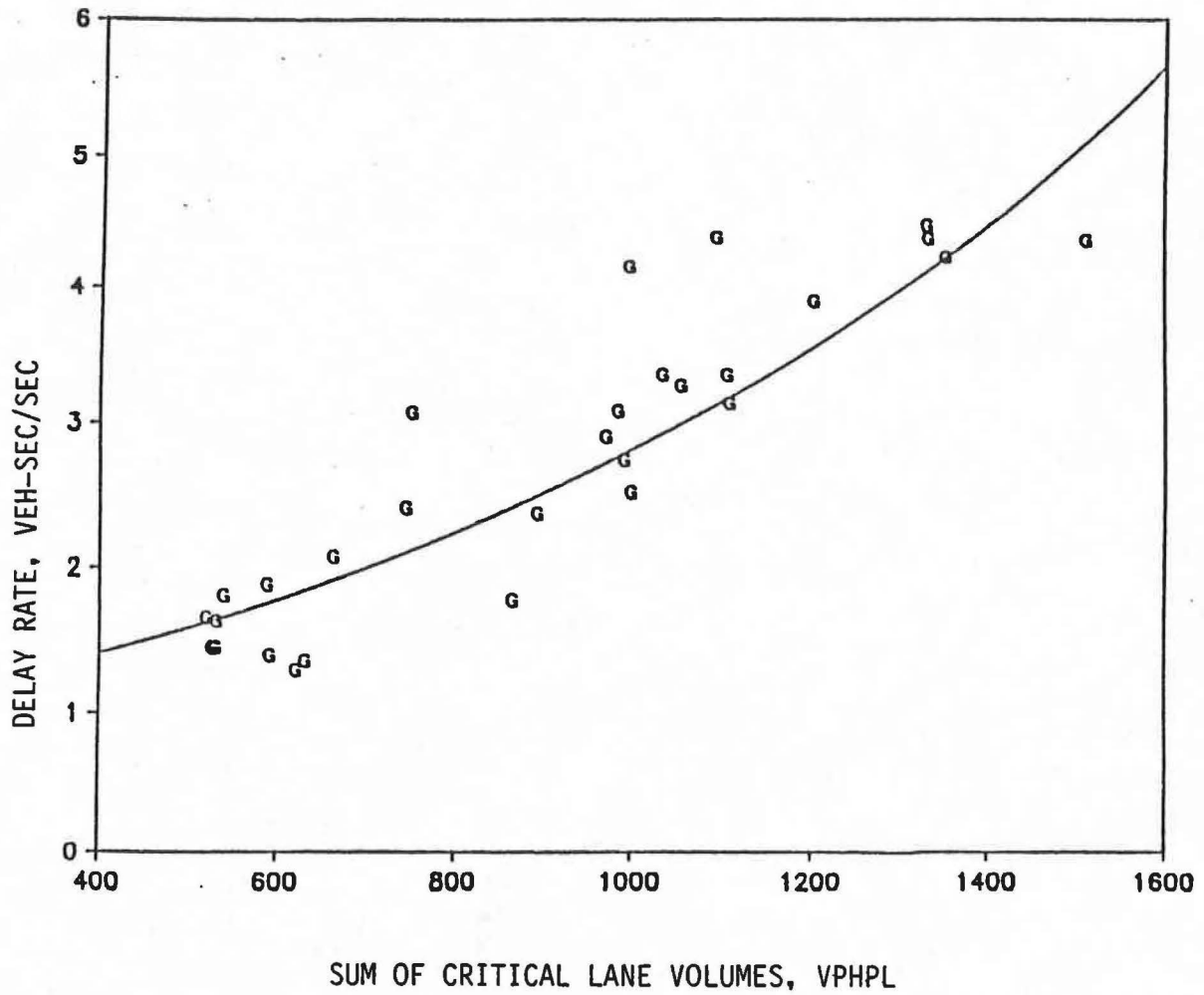

OBSERVED DELAY RATE AS RELATED TO SUM OF CRITICAL LANE VOLUMES FOR SIGNAL CONTROLLED DIAMOND INTERCHANGE

FIGURE 7

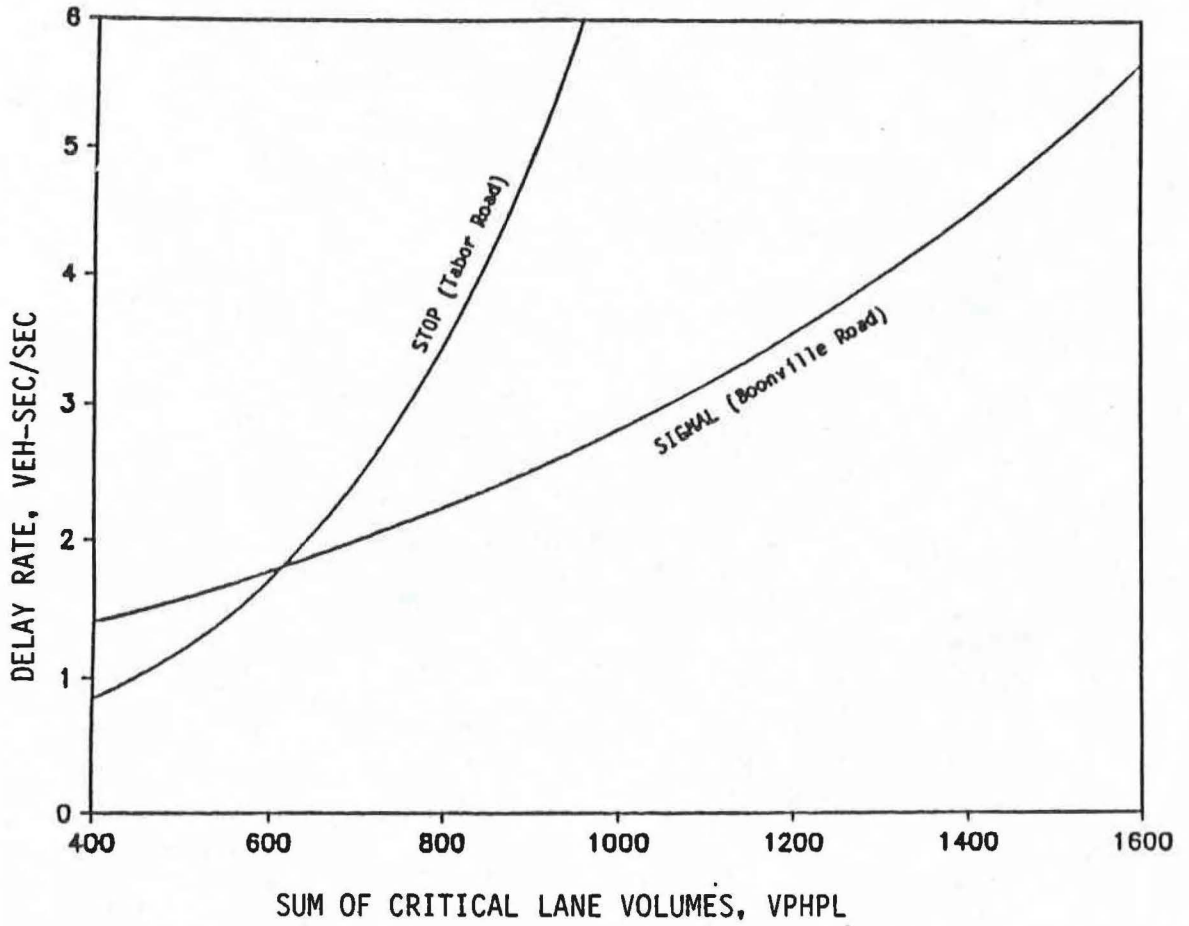

COMPARISON OF PREDICTED DELAY RATES VERSUS SUM OF CRITICAL LANE VOLUMES FOR STOP AND SIGNAL CONTROLLED INTERCHANGES

FIGURE 8

## SUMMARY

A synthesis of the previous analyses is as follows for current conditions. More likely than not, a diamond interchange having two-way frontage roads with stop control will begin to experience peak-hour congestion when the sum total daily traffic entering the interchange exceeds 20,000 ADT. The interchange will warrant a traffic signal according to the MUTCD (10) when the total ADT entering the interchange is near 30,000 vehicles per day (ADT) unless the Rural Warrant is applied. Unfortunately, this level of traffic demand is above the practical capacity of most two-way frontage road diamond interchange signal systems, if they become signalized, without major congestion forming during peak-hour traffic conditions. Thus, the installation of a traffic signal based on normal signal warranting conditions would result in continued peak hour congestion rather than relieving it as normally would be expected. This result is obviously not the intended goal of the signal installation.

This unexpected finding is believed to be due to the unusually high percentage of the total approach traffic that is left- and right-turning at diamond interchanges with two-way frontage roads as compared to normal urban intersections. Typical high-volume turning percentages range from 25% to 50% for left or right turns. At intersections, typical turning volume percentages are about 10%. At diamond interchanges with two-way frontage roads, nearly 50% of the total approach traffic is turning; whereas, at normal urban intersections, the expected value is about 20%. The effects of high turning traffic are negated to some degree with one-way frontage roads as many of the conflicting turns are eliminated because the opposing frontage road approach flows no longer exist.

The upshot of this investigation, when taken with all previous studies, is most revealing to Texas freeway design and traffic control policy. The Department should not plan to signalize diamond interchanges having two-way frontage roads using the basic MUTCD signal warrant criteria when conversion to one-way frontage roads is a feasible option. When a traffic signal is warranted, signalization of two-way frontage roads probably would create congestion during the peak hours that would be avoidable if one-way frontage road operation were implemented. In addition, the interchange with one-way frontage roads could be provided with additional capacity by providing turnaround lanes within the interchange which cannot be safely provided with two-way frontage road operations.

## TRAVEL TIME STUDIES

### INTRODUCTION

The travel time of a trip from its origin to destination is a measure of the attractiveness of the destination when it is compared to other competing options. Any increase in travel time reduces the attractiveness of the destination site. Market value of a site is directly related to its attractiveness. Thus, any highway system modification which may reduce the attractiveness of a site will logically be of concern to the owners and users of the affected property.

Conversion of frontage road operations from two-way to one-way flow has the potential for changing the travel time for trips to destinations located along the frontage roads. Increases or decreases in travel time may occur, depending on the situation. Hence, the travel times expected for a wide variety of conditions need to be predicted and examined before site specific and general system conclusions can be drawn regarding the overall merits of conversion from two-way to one-way operations.

### Objective

The objective of this phase of research was to estimate travel times for four types of trips to a wide range of destinations along the frontage roads under both two-way and one-way operations from which an evaluation could be made of the changes in travel time that would be expected to arise due to conversion. A computer program was written to perform the travel time calculations and to make the comparisons.

### Setting

Most frontage road conversions in the near future are likely to arise in two types of settings. One is an extension of an existing one-way frontage road network outward from a contiguous urban center such as San Antonio or the Dallas-Ft. Worth metroplex. The other is a local bypass or express freeway section in an isolated growing community such as Bryan/College Station.

### STUDY DESIGN

The study consisted of analytically predicting the travel times for a variety of trip types for two-way and one-way operations. A trip path which minimized travel time had to be determined for each operational case. Previously reported studies were used to estimate volumes, capacity and delays from which travel times were estimated. Some assumptions were required to make these estimations as will be described later.

### Trips Studied

Four categories of trips were investigated. Two began at trip origins located along the frontage roads; whereas, two others began on the freeway. The former two were considered local-local trips; whereas, the latter two were

presumed to have an intermediate, local frontage road destination, and then to return to the freeway once the purpose of the local stop was fulfilled. The following summarizes the four trips. Figure 9 illustrates a typical path from origin to destination for each. The return trip to the origin is not shown.

Trip 1 - Local near-side origin (O); local near-side destination (D).

Trip 2 - Local near-side origin (O); local far-side destination (D).

Trip 3 - On-freeway origin (O); local near-side destination (D). (The trip returns upstream to the on-freeway origin station.)

Trip 4 - On-freeway origin (O); local near-side destination (D). (The trip continues downstream on the freeway.)

The first three trips are assumed to have a local home-based trip origination. These trips may be to work, shop, business, or for pleasure. In any case, the total travel time for the trip is calculated from the origin to the destination and then return back to the origin to complete the loop. In this way, the total impact of the conversion process on travel time can be evaluated.

Trip 1 can readily occur on the inside (CBD-side) or outside of a bypass or loop. On the inside of the bypass, most of these trips will develop from mature neighborhoods. If an existing street system is (was) present to provide contraflow circulation for the frontage roads or has already captured these trips, then these trips will experience few problems with conversion to one-way operation. However, where new residential areas and employment centers have developed outside of the bypass (loop) since the freeway was constructed with two-way frontage roads, and where no local street contraflow circulation (or access) has developed (as in College Station, for example) that might directly serve or capture these same-side trips, then major circuitry of travel problems may develop with conversion to one-way operation.

Trip 2 reflects local near-side of freeway home-based work, shop and recreational trips to a far-side destination. This trip will commonly occur, particularly at bypasses where a new residential subdivision has been constructed outside of the bypass (or loop).

Trip 3 represents a local home-based trip which has used the freeway to reach the intended destination area. This local motorist will be familiar with the area and is assumed to advance exit at the last exit ramp before reaching the destination area, if advance exiting results in a lower trip travel time. The motorist will need to U-turn (turnaround) at the cross road interchange and return on the freeway. Numerous delays will be experienced by this trip maker at the signals and at the exit ramps. Interestingly, circuitry of travel results would be the same if the destination were on the far side.

Trip 4 reflects the trip of a non-local tourist who is traveling along the freeway and desires to use a local service such as a restaurant, gas station or motel. It is assumed that the motorist ultimately continues beyond his local near-side destination to a downstream freeway destination. Far-side destinations have the same circuitry as Trip 2 with the origin of trip 0 located at the appropriate cross road interchange, depending on whether the far-side destination is upstream or downstream of the crossover.

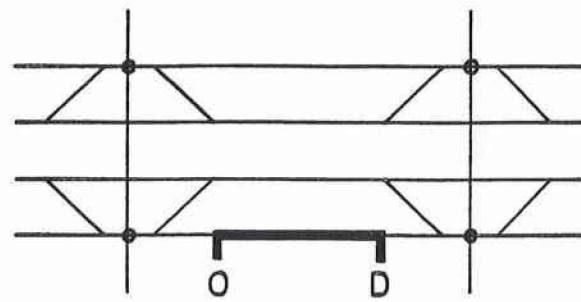

TYPE 1

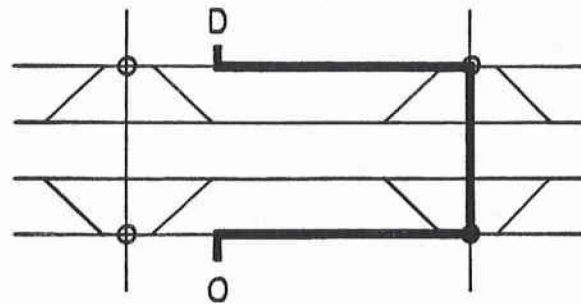

TYPE 2

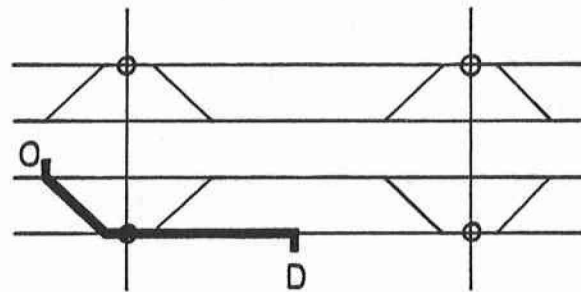

TYPE 3

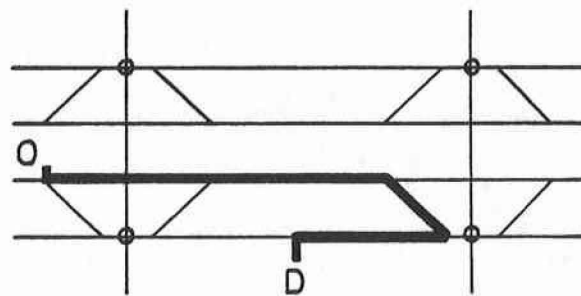

TYPE 4

← SPACING = S →

FOUR TYPES OF TRIPS EVALUATED IN TRAVEL TIME STUDIES

FIGURE 9

## Travel Time Measure

The measure of the impact of conversion from two-way to one-way frontage road operations is given by the change in travel time that accrues to various trips following conversion. This change in travel time is defined as follows:

$$C_{ODT} = TT_{ODT1} - TT_{ODT2}$$

where

$C_{ODT}$  = change in travel time for trip from origin O to destination D and return (usually) for trip type T, seconds.

$TT_{ODT1}$  = predicted travel time for the round-trip (usually) for one-way frontage roads, seconds.

$TT_{ODT2}$  = predicted travel time for the round-trip (usually) for two-way frontage roads, seconds.

A positive change in travel time would result when one-way operation would require more travel time to complete the trip than would two-way. More circuitry of travel has been added. A negative value means one-way is faster.

## Geometric Design Factors

There are several geometric design options which have an important impact on the travel times of trips within the freeway - frontage road system. These geometric features include:

1. Provision of a local street circulation system.
2. Spacing between the freeway's cross road interchanges (and cross overs).
3. Design of the interchange, including the provision of U-turn lanes, free right turn lanes, intersection capacities, and signal phasing.

The traffic carrying capacity is a controlling feature at high-volume conditions, as the previous section of this report demonstrated. The capacity of diamond interchanges having two-way frontage roads is usually less than with one-way operations and the resulting operational delays for left-turning vehicles are typically much higher during peak hours.

## Assumptions

Several assumed values of variables were made in the traffic modeling process. All freeway interchanges were assumed to be diamonds. Exit ramp to entrance ramp spacing through the diamond interchange was selected to be 1,000 feet. Frontage road separation distance at the interchanges was selected to be 500 feet. Some rural interchange spacings are much more, but this is not a sensitive variable for relative analyses. A 15-mph speed differential was assumed between the speed of traffic on the suburban freeway and the frontage roads. More particularly, the freeway speed was assumed to be 55 mph. The frontage road speed was assumed to be 40 mph.

Table 10 presents a summary of traffic delay values assumed for freeway ramps and at the interchanges. Delays were estimated for entrance ramps and exit ramps. Delays at ramps are caused by the frontage road traffic having to yield right-of-way to traffic entering and exiting the freeway. Traffic delays at the ramps were estimated from project studies presented in study report 402-2 (8). Interchange turning movement delays were estimated from the capacity and delay studies described earlier. All interchanges are assumed to be signalized and direct connecting frontage roads are assumed to be present. This may not be the case in rapidly growing rural-fringe areas. These delay values were presumed to reflect a v/c ratio at the diamond interchange of about 70 percent of capacity for two-way frontage road operations. A higher v/c ratio would have resulted in higher delays.

**TABLE 10**  
**ASSUMED DELAYS AT RAMPS AND INTERCHANGES**

Highway Elements	One-Way F.R. Delay (seconds)	Two-Way F.R. Delay (sec/veh)
Exit Ramps	3	10
Entrance Ramps	-	5
Left Turns	15 (4)*	30
Throughs	15	20
Right Turns	10	15

\*Left turn delay of 4 sec/veh if U-turn lanes are present.

## RESULTS

The results of the computer analyses of the predicted travel times for the four trip types described previously will follow. Origins of trips were systematically varied in 1,000-foot steps, beginning at the upstream cross road interchange and stepping downstream to the downstream interchange. For a given origin, a trip's destination would then be sequentially defined over the same range of frontage road locations in 1,000-foot steps. Computations of minimum travel time paths were then made for each trip (an origin-destination pair) for both one-way operation and two-way operation. Calculations of the changes in travel time from two-way to one-way operations were made for each trip. The impacts of this hypothetical conversion process were found often, but not always, to result in increases in travel time due to a more circuitous route with one-way flow. This increase occurs only when there is no local street system to provide "contraflow" capabilities for the one-way frontage road traffic. This increase in travel time is sometimes described by the short term "circuitry."

The results of the changes in travel time are reported in plots of added (usually) travel time for the four trip types previously described in Figure 9. For each trip, four cases were examined which were envisioned to represent principal alternative decision scenarios of planning, design and operations. The four cases studied were as follows:



1. A base case wherein the trip ends (O:D) have no local access to the cross road, except at points of interchange (i.e.,  $D = O$ ,  $D = S$ ). No contraflow is possible with one-way frontage roads and all circulation is counterclockwise. No U-turn lanes are present at the interchanges.
2. Same as case 1, but U-turn lanes are present, saving 44 seconds of travel time to complete the total round trip from O to D and return.
3. Same as case 1, but cross road access is provided by the local street system in the contraflow direction.
4. Both U-turn lanes and contraflow circulation provided by local street system are present.

The findings from each of these cases are reported for each trip. Comparative figures are presented for some cases but not necessarily for all of them.

### Trip Type 1

This trip, as described in Figure 9, is presumed to be a local trip destined to a local destination both of which are on the same side of the freeway. Frontage roads are presumed to be used as a possible alternative route to the local street system. Should the local street system not exist, then the frontage roads would have to serve the total trip, from O to D and return.

An examination of the travel times for these trips is most revealing. Without contraflow access on the local street system, a complete trip on one-way frontage roads is always made in a counterclockwise loop. The total loop travel time is a constant for a given interchange spacing regardless of the origin and destination locations (O:D). This is true even if the destination D is located on the opposite side of the freeway.

Figure 10 presents the additional travel time required for all possible trip combinations for 5,000-foot and 15,000-foot separation distances in 1,000-foot increments between the cross road interchanges. No contraflow circulation access is assumed and no U-turn lanes are provided. Travel times are observed to increase as the separation distance between interchanges increases. Inspection of Figure 10 also reveals that the worst impacts arise, with conversion to one-way operation, when the origin of the trip and the destination of the trip are very close together but no contraflow access provided by local streets is available between them.

Consider the following two examples for the two interchange spacings shown in Figure 10. For an interchange spacing of 5,000 feet shown in the lower portion of Figure 10, the added travel time due to conversion for a trip originating 5,000 feet from the upstream interchange destined to near-side location 4,999 (i.e., one foot upstream), as an extreme case, is about 240 seconds, or 4 minutes. The upper part of Figure 10 shows that the circuitry of travel for the same trip made with an interchange spacing of 15,000 feet is significantly increased to about 600 seconds, or a staggering 10 minutes.

Conversion is observed to require much longer travel times for this trip, increasing with interchange spacing. Consequently, mixing of residential and

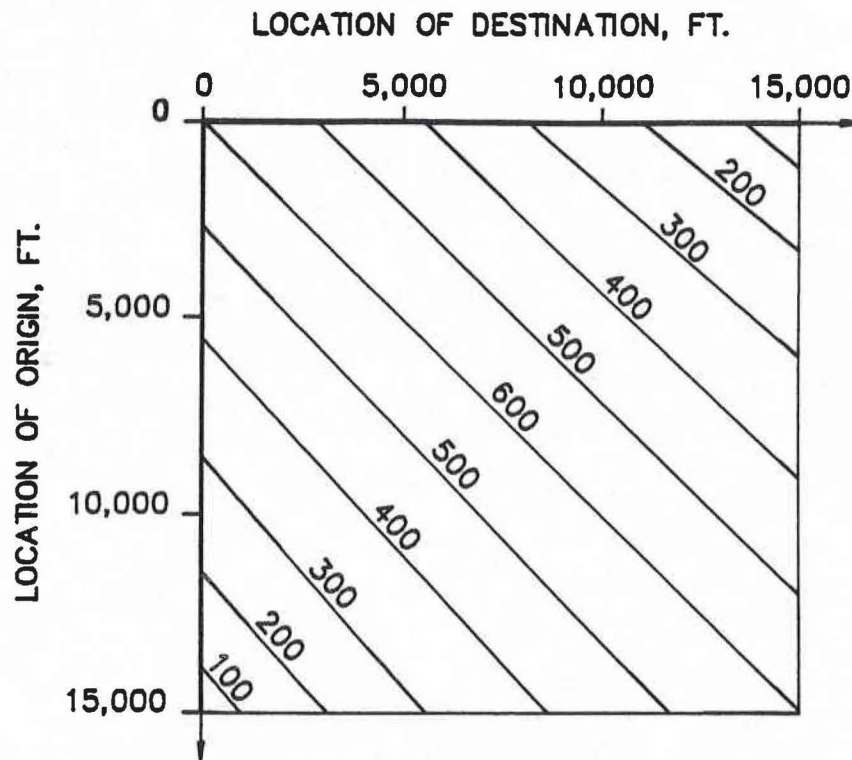

a) 15,000-FT. INTERCHANGE SPACING

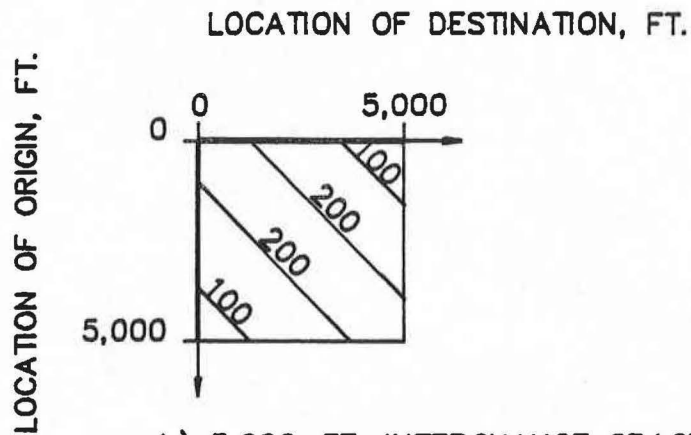

b) 5,000-FT. INTERCHANGE SPACING

ADDED TRAVEL TIME (SECONDS) DUE TO CONVERSION FOR  
5,000-FT. AND 15,000-FT. INTERCHANGE SPACINGS FOR TRIP TYPE 1

FIGURE 10

employment centers (or shopping centers) should be avoided in this situation until direct access between them is available on the local street system. It follows that efforts by local officials to discourage these developments should be increased in towns where the separation distance between interchanges is large until a direct connecting, local street system is provided.

When U-turn lanes are provided for Trip 1, a figure similar in shape to Figure 10 will result. The only difference will be an absolute reduction of 44 seconds in added travel time, which is the estimated savings in travel time of four left turns (two at each of the two interchanges) due to the provision of turnaround lanes at the interchanges having one-way frontage roads. Consequently, this similar figure is not presented.

There is no circuitry of travel when converting from two-way to one-way operations when the local street system provides contraflow access equivalent to two-way frontage roads. This is a very important point. There appears to be no other feasible treatment for this trip type (Trip 1) once it develops along the freeway. Avoidance of this trip to the extent possible through various government actions (planning, zoning, and driveway access control) until a back-up street system is available is probably the best treatment.

## Trip Type 2

Circuitry of travel for Trip 2, local-local near-side origin to far-side destination, was examined for the four cases.

Figure 11 depicts the calculated results for case 1 for a separation distance between interchanges along the freeway of 15,000 feet. That is, the distance between cross road access points (and turnarounds) to the far side of the freeway is nearly three miles (15,000 feet). The 100-second contour lines illustrate the locations of trip ends (O:D) where little, if any, added travel time occurs and also locations where extreme circuitry arises. Little, if any, added travel time is noted in the 0-second diagonal band crossing the area (domain) with the center of the band found from the equation  $O + D = S$ . The width of the negative band (positive benefits due to conversion) is about one-half mile wide (2,500 feet). When U-turn lanes are present, as is often the case in urban areas, the width of the negative band will be about 5,000 feet (or one-mile). That is, one way frontage road operation would produce travel times less than two-way operation along about one mile of frontage road.

Studies were conducted for spacings between interchanges of 5,000, 10,000 and 15,000 feet. These evaluations showed that circuitry of travel for this trip type is directly and linearly related to the separation distance between interchanges. The longer the spacing between crossovers, the higher the travel time following conversion for the new areas added. Conversely, a reduction in spacing from say 15,000 feet (the total area of Figure 11) to 5,000 feet reduces the circuitry of travel in the three newly created zones to that given by a 5,000-foot by 5,000-foot square window placed in the lower left corner of Figure 11. A 10,000-foot spacing would be represented by a 10,000 x 10,000-foot window placed in the lower left corner, and so on.

Circuitry comparisons can then easily be made from Figure 11 for different spacings between interchanges for this trip type having no contraflow access or U-turn lanes. Maximum additional travel time (circuitry of travel) would be

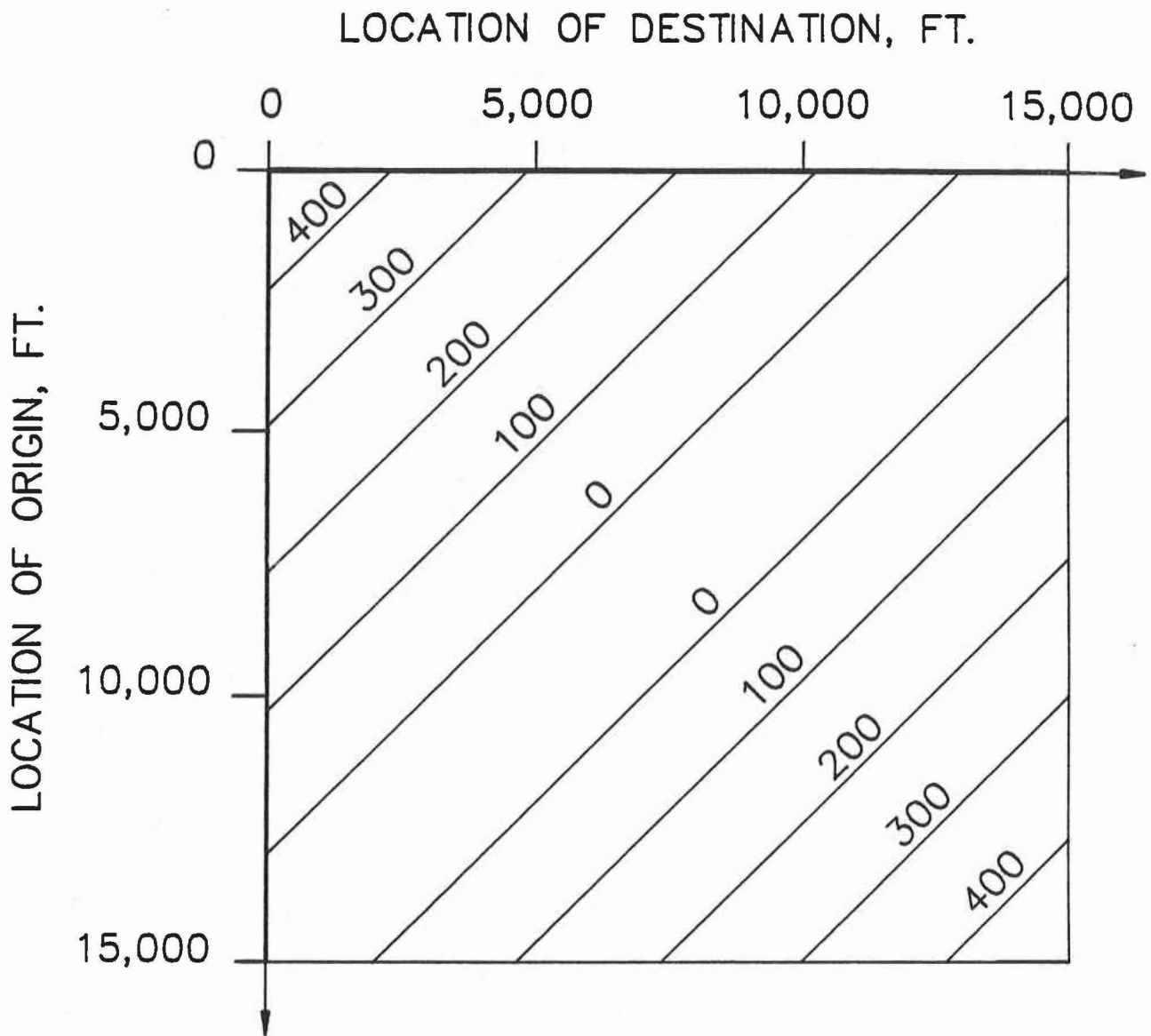

15,000-FT. INTERCHANGE SPACING

ADDED TRAVEL TIME (SECONDS) DUE TO CONVERSION FOR  
15,000-FT. INTERCHANGE SPACING FOR TRIP TYPE 2

FIGURE 11

about 120 seconds for a 5,000-foot spacing, about 290 seconds for a 10,000-foot spacing, and about 460 seconds for a 15,000-foot spacing. These comparisons can be determined by locating progressively larger windows of appropriate size beginning from the lower left corner of Figure 11, as described previously.

A figure for trip ends studied in Figure 11 could have been developed for the case where contraflow access is provided by a local street system, primarily to the benefit of one-way operation. This figure was not developed because there are basically no differences between the travel times with one-way and two-way operations. Some slight reductions in travel time (benefits) do exist due to one-way operation along the valley diagonal of Figure 11 where  $O + D = S$ . Maximum savings are 33 seconds (i.e. - 33). Most values are zero. It is very important to note, however, that contraflow access must be provided by the local street system at both the origin of the trip (at O) and at the destination of the trip (at D) for the travel circuitry to be eliminated. Provision of local circulation at only one trip end (on only one side of the freeway) does no good for this local-local trip. Both trip ends (on both sides of the freeway) must have contraflow access; otherwise, circuitry remains the same as that given by case 1, as depicted in Figure 11.

Provision of U-turn lanes together with local circulation access saves an additional 46 seconds of travel time when conversion to one-way operation occurs for all trip ends of Type 2. Since all added travel times values are between 0 and -79 seconds, no 100-second travel time contours would show in a figure similar to Figure 11.

### Trip Type 3

Changes in travel for trips presumed to originate on the freeway can be analyzed similar to the previous two cases. The exact origin of the trip is unknown but its local origination point O is assumed to be on the freeway at the off-ramp to the upstream cross road. Minimum travel time paths are then computed to any subject destination D to determine whether the smart motorist (the local motorist is presumed to be experienced and will know the best path to take) will exit in advance of the cross street or will stay on the freeway to the next downstream exit ramp near the destination D. Minimum travel time paths back to the origin are also computed. Similar logic is applied to all feasible alternative routes for one-way and two-way frontage road flow.

Figure 12 presents the predicted changes in travel time for three interchange spacings of 5,000, 10,000 and 15,000 feet for this trip type. Conditions with local street contraflow circulation (lower curves) and without local circulation (upper curves) are depicted. The presence of U-turn lanes would simply reduce the added travel time by about 22 seconds for all cases.

The significance of interchange separation distance and presence of local streets providing contraflow access (with one-way frontage road flow) can be determined from the curves presented in Figure 12. The three lower curves show results with local streets; whereas, the upper three are results without local streets providing contraflow movement (with one-way frontage roads). The following examination of these curves will highlight significant relationships.

A freeway trip to a local, near-side destination 1,000 feet downstream of the first cross road interchange is noted in Figure 12 to experience an

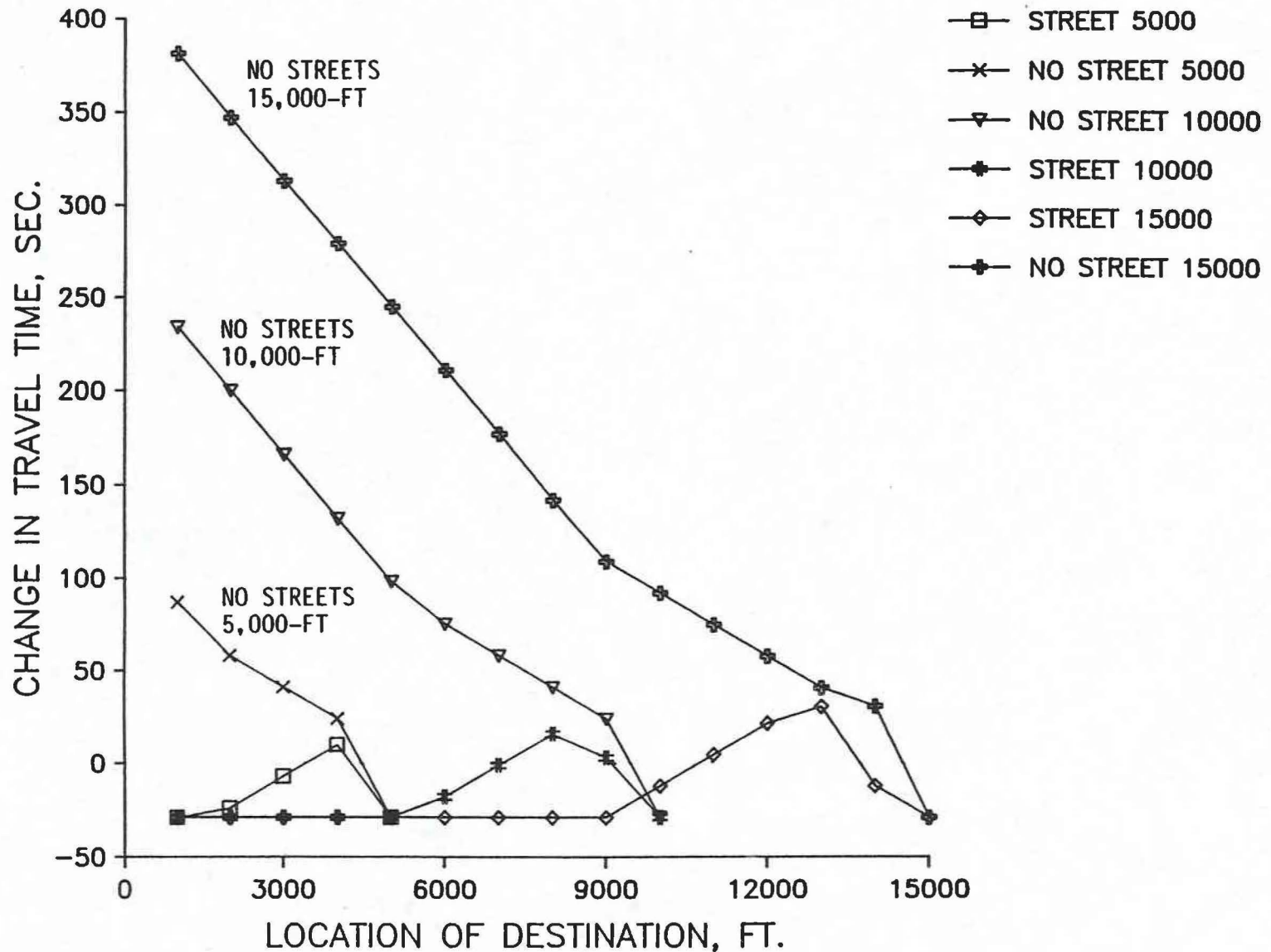

CHANGES IN TRAVEL TIME DUE TO CONVERSION FOR TRIP TYPE 3 -- A LOCAL TRIP

FIGURE 12

additional travel time of nearly 400 seconds for the total trip due to frontage road conversion when the two interchanges are spaced 15,000 feet apart, assuming no contraflow possible on the local street system. This destination is located 500 feet downstream of the entrance ramp to the freeway - an obviously poor site for this U-turning trip with one-way frontage roads. Figure 12 also shows that the added travel time (and circuity of travel) is reduced for these conditions as the destination approaches the downstream interchange. This is mainly due to the reduction in benefits provided by the contraflow between the destination and the upstream freeway cross road interchange with two-way frontage road operation. One-way operation requires that the advance exiting trip continue from the local near-side destination on to the next downstream cross road interchange, which is located at  $S = 15,000$  feet in this example. Note that when the destination is close to the downstream exit ramp, the wise local motorists may travel to the downstream exit ramp, exit, and then travel contraflow to the destination.

Reductions in added travel time due to conversion can be observed from Figure 12 as interchange spacing is reduced from 15,000 feet to 10,000 feet, and finally to 5,000 feet for the condition of no local street system and local, smart motorists. The added travel time to the 1,000-foot destination is reduced from 380 seconds, to 240 seconds, and finally to 90 seconds, respectively. The primary reason for this improvement is the more expedient return to the freeway for the motorist using one-way frontage roads who has to travel downstream to the cross road interchange before returning.

The lower three curves show the dramatic reduction in circuity of travel that would result for motorists traveling to destinations near the upstream interchange if contraflow access is provided by local street circulation. As can be seen in Figure 12, travel times may be reduced, not increased, after conversion due to the improved flow that can be provided through the signalized diamond interchanges with one-way frontage road operation. This fact also is a major reason for legitimate concern by an owner of a business located thereon presently facing conversion to one-way operations, a long spacing to a downstream interchange, and no foreseeable provision of a local street system. Conversely, the business would not be so disadvantaged if it were only slightly upstream of the downstream exit ramp. To be sure, this minimal negative impact holds only for local motorists who would know by experience to advance exit as the best path to the destination. As the following trip type will show, such minimal consequences do not result for uninformed motorists, such as tourists.

#### Trip Type 4

This trip type is presumed to represent the tourist trade in the freeway corridor. As Figure 9 depicted, this trip initially is assumed to exit the freeway after passing the first cross road interchange with the exiting maneuver performed at the subsequent downstream off-ramp. The motorist then would visit a local near-side destination at D, return to the freeway at the best entrance ramp available, and then continue downstream on the freeway. A critical assumed difference in travel of this trip maker, as compared to Trip Type 3, is that the non-local tourist may not exit the freeway in advance of his best exit. The freeway motorist may not know the best exit until seeing the business while traveling by it. This is more likely to be the case with diamond interchanges having exit ramps in advance of the upstream cross street. It is possible that commercial advertising may inform tourists to advance exit

and, if this is so, then this would be a major benefit to these motorists as the following analyses will demonstrate.

Figure 13 presents comparisons of added travel time for two types of circulation. The basic case assumes no contraflow circulation is provided by the local street system from the exit ramp to the intended destination at D except by two-way frontage road operation. The tourist is presumed not to advance exit. Three interchange spacings of 5,000, 10,000 and 15,000 feet were examined. As the upper graphs of Figure 13 show, circuitry of travel will be a problem for all business locations between the interchanges. Circuitry of travel will exceed two minutes (120 seconds) for all of these potential destination locations, even for the shortest interchange separation distance of 5,000 feet. Circuitry of travel is observed to increase as separation distance increases from 5,000 feet to 15,000 feet, always being a maximum just upstream of the exit ramp location to the downstream diamond interchange. Not shown in Figure 13 is the dramatic reduction in travel time to a negative value that occurs between the exit ramp and the downstream cross road. One-way flow along this stretch actually provides better conditions than does two-way due to improved traffic flow at the interchange. This is a fact well recognized by all major oil companies and tourist-oriented corporations.

The lower three curves of Figure 13 show that circulation from the exit ramp back to the site with one-way frontage road operation dramatically reduces conversion impacts. This analysis assumed that contraflow circulation was not provided back to the upstream entrance ramp, but only to the site location. Consequently, some circuitry is noted beginning at the upstream cross road interchange (assumed to be at station 0 feet) and steadily being reduced to zero at some downstream location, depending on interchange spacing. For a business catering to tourists and located just upstream of an exit ramp, given a 15,000-foot interchange spacing, circuitry is reduced from nearly 600 seconds to practically zero with provision of contraflow circulation. It should be noted that a complete local street system between the cross roads totally eliminates all circuitry of travel, including that shown near the upstream cross road.

Circuitry of travel for these tourist trips is practically eliminated as a problem for most all cases if the tourists would exit in advance of the intended destination. Figure 14 illustrates the significant reduction in travel times for the basic two-way conversion case versus conversion results for the advance exit option with one-way flow. To achieve the desired advance exiting maneuver, tourists must be informed of the targeted downstream destinations. Commercial signing placed alongside the roadway may already perform this function. If roadside signing isn't already in place, motorist information signing would be most useful for this trip.

Motorist information signing to treat the above noted circuitry problem would only be warranted where all of the following conditions occur:

1. A major tourist-oriented business presently is located along a section of two-way frontage roads between an entrance ramp and an exit ramp.
2. Conversion to one-way frontage roads is eminent.
3. No contraflow access is available from the downstream exit ramp upstream to the business.



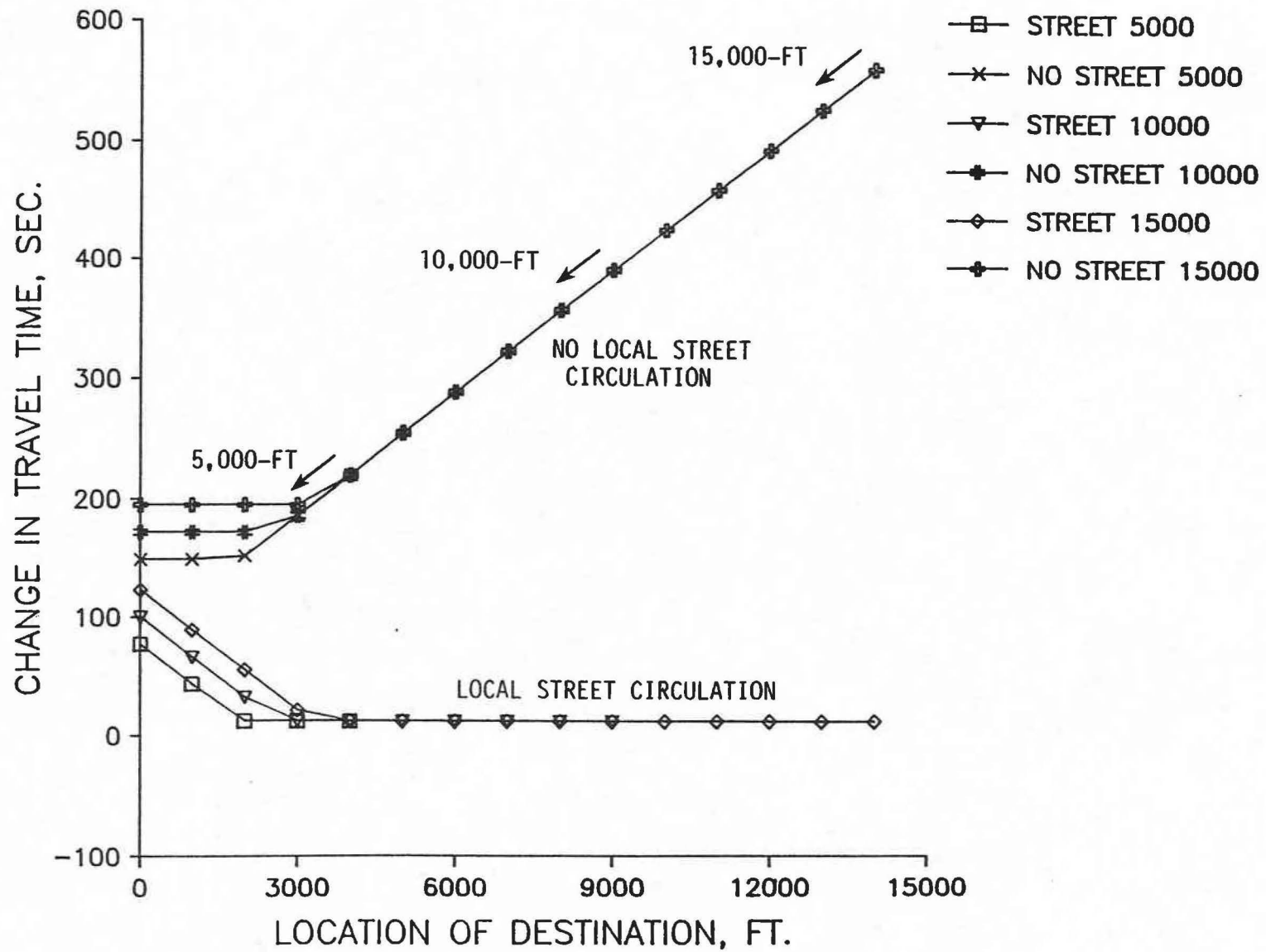

CHANGES IN TRAVEL TIME DUE TO CONVERSION  
FOR TRIP TYPE 4 — A TOURIST TRIP

FIGURE 13

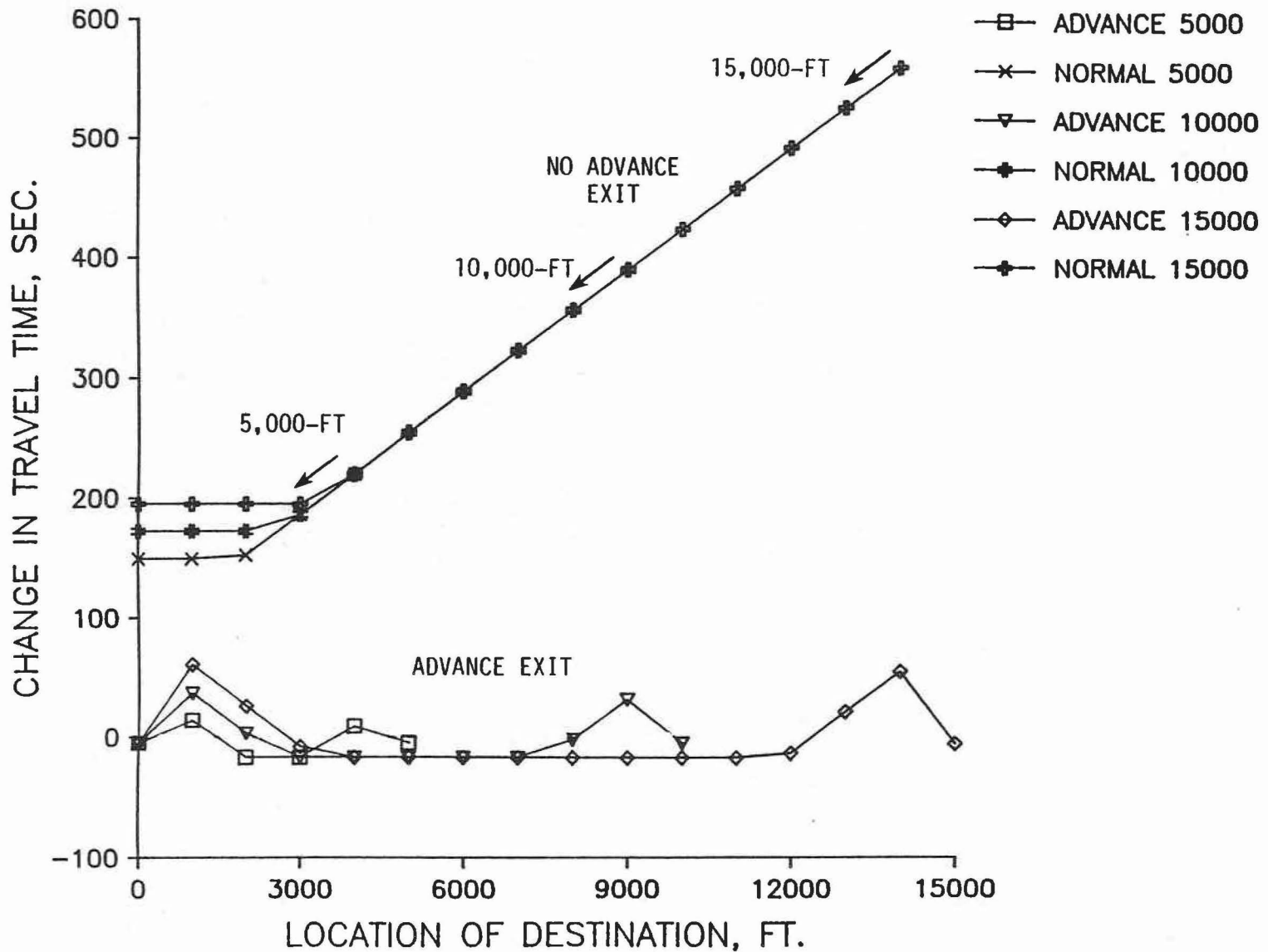

CHANGES IN TRAVEL TIME DUE TO CONVERSION  
FOR TRIP TYPE 4 -- A TOURIST WHO ADVANCE EXITS

FIGURE 14

4. Advance commercial signing for the business is neither present nor would be feasible.

What can be done, in addition to the provision of a local street system and motorist information signing, to help the situation described above? The best remedy is to avoid locating a business which caters primarily to tourist trade upstream of an exit ramp without having local street access to the cross roads. In addition, three geometric treatments are possible in some cases. One might be to install a second freeway exit ramp in advance of the existing exit ramp. This has the effect of backing up the exit ramp. Whereas backing up the exit ramp option may not be practicable, the second exit ramp might be. A second geometric treatment for consideration is the provision of X-Ramp configurations for the adjacent cross road interchanges. Access to the cross road would not be needed and exiting from the freeway to the problem site would be made easier. Funding of local street or county road improvements using state highway department funds to build a short section of a local street to the site might also be an appropriate option to consider in some circumstances.

Where no freeway-oriented business currently exists, avoidance of future prospects is the best remedy. Expedient conversion to one-way operation reduces the likelihood that this situation will arise since prospective site developers will have to address the same issues - advance information, contraflow access, and circuitry of travel. They would then be encouraged for economic reasons to support local efforts to build a local street system which provides the desired contraflow access to their property.

## WARRANTS FOR CONVERSION

### SCOPE

A warrant for frontage road conversion is a set of measurable criteria whose threshold values define the expected transition from a region where two-way frontage road operation is generally desired to a region where one-way frontage road operation is generally preferred. The measurable criteria should be continuous, easy to understand, and readily available.

As the studies reported in the previous sections have shown, several operational criteria have been identified which the general public recognize as being reflective of progressively deteriorating traffic conditions, given that two-way frontage road flow exists. These operational measures are:

1. Traffic accidents
2. Ramp conflicts
3. Vehicle delays at signals and ramps
4. Traffic congestion
5. Added travel time

As the values of these variables increase, traffic conditions on the whole would be judged to become worse than before. Conditions could ultimately become intolerable with increasing traffic growth, unless some other ameliorating option can be identified and implemented.

The previously reported studies and the literature have demonstrated that all of the principal operational measures (accidents, conflicts, delays and congestion) increase with increasing traffic volume. In addition, all of these measures are logically related to volume for a given quality of design and control. Moreover, volume is understood, readily available, and already is a common warrant measure in other related traffic engineering applications. Consequently, the following warrants presented for conversion from two-way to one-way frontage roads will be volume based, reflecting the overall considerations of safety and capacity within the frontage road corridor.

### RECOMMENDED WARRANTS

Warrants for conversion from two-way to one-way frontage road operations are defined in three levels. These levels are reflective of perceived future needs of the Department together with a sensitivity to data requirements. The overall goal of the warrants is to achieve the safest and most efficient traffic flow possible using either two-way or one-way frontage road operation.

The basic warrant describes the fundamental objective of the warrant which is then followed by the data sensitive application warrants. The second-level warrant is based on average daily traffic, which should be sufficient to meet the needs of the Department in many cases, followed by a third-level warrant, which is very sensitive to site specific characteristics. The third warrant is based on peak-hour turning movement volumes at the individual interchanges and is, therefore, data intensive.

## Basic Warrant

Two-way frontage roads should be converted to one-way operation when the safety and operational benefits predicted for one-way operation exceed those estimated for existing two-way flow based on related traffic volume measurements. It is presumed that these threshold warrants will define the transition to the beginning of a continuous period of future beneficial conditions since traffic demand in Texas has been steadily increasing by over 2 percent per year. Where local conditions are favorable for conversion, it is desirable that conversion should be implemented as soon as practicable. Where local conditions are not considered favorable for conversion, conversion may be delayed until traffic conditions degrade to minimum acceptable levels.

Should conversion be delayed beyond desirable conditions, actions should be taken to improve interchange capacity and all other aspects within the freeway corridor that would expedite the pending conversion process. While undesirable from a cost viewpoint, signalization of the existing two-way frontage roads will likely be a necessary consequence of any delayed response. If so, the need for this signalization should be based on the MUTCD traffic signal warrants using the small-town (less than 10,000 population) reduction factor of 70% applied to the basic volume levels.

## Average Daily Traffic Warrant

Conversion to one-way frontage road operation may be warranted based on traffic demands estimated for the average day of the year. These average vehicle counts are the total traffic counted (or estimated) during an average 24-hour day entering the total of eight approaches of the two intersections which compose the interchange. This warrant estimates the threshold conditions described previously for the basic conversion warrant. The ADT values given in Table 11 define the warranting average daily traffic volumes. These ADT volumes were derived from Table 5 and rounded to the nearest 2,500 vehicles per day to reflect their approximate nature. Two categories of local conditions are defined: 1) Desirable - where local conditions are favorable for conversion, and 2) Minimum - where local conditions are not favorable for conversion and traffic operating conditions have reached minimum acceptable conditions.

The ADT values of Tables 5 and 11 were derived assuming a 30-th hourly volume factor (a K-factor) of 0.084 together with a peak hour factor (PHF) of 0.90. Recall that the K-factor estimates the fraction of the average daily traffic that occurs during the peak hour, and the PHF estimates the ratio of the peak hour volume to the peak 15-minute flow rate as defined within the 1985 Highway Capacity Manual (9).

The previous ADT warranting volumes given in Table 11 also approximate Woods' (7) safety warrant levels previously described in Table 6. Woods' Rural warrant occurs near a total interchange ADT of 37,500 vehicles per day, which is the same as Minimum conditions for a four-lane cross road with left turn lanes interchanging with two-lane, two-way frontage roads. His Intermediate warrant occurs near an ADT of 30,000 vehicles per day, which is likewise the same as Desirable conditions for the interchange.

TABLE 11

**AVERAGE DAILY TRAFFIC VOLUMES ENTERING AN INTERCHANGE THAT WARRANTS  
CONVERSION OF FRONTAGE ROADS FROM TWO-WAY TO ONE-WAY OPERATION**

No.	Description of Interchange		Warranting Conditions	
	Cross Road	Frontage Road	Desirable	Minimum
1.	2L	2L	20,000	25,000
2.	2L + LT	2L + LT	27,500	35,000
3.	4L + LT	2L	30,000	37,500
4.	4L + LT	2L + LT	35,000	42,500

2L + LT = 2 lane road with left turn lanes.

It is informative to note that expected traffic conditions would be dramatically improved if one-way operations were implemented at the warranting levels. Congestion and delays are estimated to be reduced at the interchanges and ramps by about 35% during the peak hours. Safety will be significantly improved at all freeway ramps and interchanges.

With one-way frontage roads, interchanging traffic will be able to make legal left and right turns on a protected signal phase. These turns will all be protected from oncoming traffic. Motorist anxiety will be reduced because operations will be much more orderly and predictable.

**Peak-Hour Traffic Warrant**

This warrant defines when conditions justify conversion to one-way operation based on traffic conditions predicted to occur during the peak hour of the average day. Indirectly, through the applications of the K-factor, the warrant also represents average conditions for the average day. More particularly, however, it accurately represents delay and capacity conditions during the rush hours for the site specific characteristics of each interchange. Few assumptions are required but more laborious turning movement traffic counts are required.

When local conditions are favorable for conversion to one-way frontage road operation, it is desirable to convert from two-way to one-way flow when the existing traffic volumes on the critical turning movements at the signalized (actual or assumed) diamond interchanges reach 65 percent of their phase capacity during the peak 15-minute period of the morning or afternoon peak hour. At least two conflicting movements within the interchange must be critical for this warrant to be satisfied.

When local conditions are not favorable for conversion to one-way operation, conversion is warranted when the previous critical traffic movements reach 80 percent of their respective phase's capacity. This is considered a minimum tolerable condition.

Application of this peak-hour warrant presumes that several requirements are met. Reliable turning movement counts for all eight approaches for each interchange are required. Optimal signal phasing and timing are presumed. A

reliable capacity measurement technique is needed. The new SDHPT computer program, PASSER II-87, is highly recommended to be used for conducting these signal timing and capacity studies for signalized diamond interchanges having two-way frontage roads.

## **CORRIDOR CONDITIONS**

Local conditions are an important consideration when evaluating the relative merits of conversion. When local conditions are favorable, it may be desirable to expedite the conversion process from two-way to one-way operation to more quickly improve safety and traffic flow. In addition, conversion to one-way flow decreases the likelihood of future developments occurring which might be incompatible with one-way flow without a local street system.

Circumstances which promote a more favorable environment for conversion include transportation planning and highway design aspects. Planning issues include the types and number of trips made, their respective destinations, and available alternate routes. Design features include spacing between interchanges, sizing of interchanges for capacity, and provision of ramps.

### **Trip Characteristics**

As the previous travel time studies in this report have illustrated, the types of trips occurring in the freeway corridor will be impacted differently by frontage road conversion, depending on the local conditions. To assess these impacts, a study should be conducted of the nature of the following four types of trips studied earlier (See Figure 9.):

1. Local near-side to near-side trips that presently use the two-way frontage roads in the contraflow direction.
2. Local near-side to far-side trips that presently use the frontage roads in the contraflow direction.
3. Local freeway to near-side or far-side U-turning trips that presently use the frontage roads in the contraflow direction.
4. Tourist (non-local) trips that stop alongside the freeway to trade at local restaurants, service stations and motels, etc. Again, examine only those trips that contraflow along the frontage roads.

Only those trips being made along the frontage roads in the contraflow direction may be a problem when the frontage roads are converted to one-way flow. Consequently, a critical examination of the present conditions would need to document the number of trips made in the contraflow direction versus the normal flow direction for each trip type.

It is also important to note the destinations of contraflow trips because the true impact of conversion depends on whether the contraflow trips are presently using captive or preferred routes. For example, Trip 3 above may be a local shopping trip made from the freeway to a local automobile agency located upstream of an exit ramp. This contraflow trip is presently preferred

by the trip maker but he is aware of a similar quality normal flow path along the frontage road (advance exiting type) that he could conveniently take if the frontage roads were converted to one-way. These subtle differences in trip characteristics should be discovered in the study because, as Figures 12 and 14 depict, major differences in circuitry of travel consequences may occur. In fact, the local owner of the business may fear major negative consequences, but travel conditions in fact may possibly improve with one-way operation.

### Local Street Circulation

The provision of contraflow circulation with local streets is the most important alternative to ameliorating potential increases in travel time due to frontage road conversion for some trips. Refer to Figure 9 for descriptions of trip types. The need for and location of local street circulation has been shown previously to depend on the trip type and destination, as the following discussion illustrates:

1. Trip Type 1 - Local street needed on one side only between the origin and destination of the trip. The more critical trips can be determined from Figure 10.
2. Trip Type 2 - Local streets needed on both sides of the freeway between the destination contraflow to the adjacent cross road and between the same cross road contraflow to the origin. See Figure 11 to determine which trips are more critical. Generally, they are those with origins and destinations opposite each other and near to the cross road, but with no contraflow access to it.
3. Trip Type 3 - Local street needed on one side only between destination and upstream cross road. See Figure 12.
4. Trip Type 4 - Local street needed on one side only between downstream exit ramp and upstream destinations. Tourist-oriented businesses should be strongly discouraged from locating upstream of exit ramps on two-way frontage roads where conversion is possible during the expected economic lifetime of the business unless convenient local street contraflow access will be available when the business opens. This is a common problem and requirement for all business located along most freeways in the United States since contiguous frontage roads usually are not provided outside the state of Texas. Placement of motorist information signing in advance of the upstream exit may reduce the conversion impacts by encouraging tourists to advance exit and thereby save considerable travel time.

### Spacing Between Interchanges

The spacing or separation distance between cross road interchanges has been shown in the travel time studies to be an important contributor to the quality of conditions for conversion. Circuitry of travel increases for all trip types with increasing spacing between the interchanges. As a subjective guide, based on Figure 2 and Figures 11-14, the following quality of conversion descriptors can be placed on separation distance between interchanges:



Separation Distance (Miles)

Quality for Conversion

$0 < SD < 1$	Favorable
$1 < SD < 2$	Fair
$2 < SD$	Unfavorable

As a general application guideline, the separation distance between interchanges or crossovers should not be greater than 10,000 feet for the section of freeway to be favorably considered as being desirable for conversion to one-way operation. The closer the distances between interchanges, the more favorable the conditions are for conversion. A practical minimum optimal spacing is about 4,000 feet. Refer to Figure 2 for estimates of the distributions of interchange spacings for urban, town and rural areas. Clearly, some potential exists for some unfavorable interchange spacings greater than 2 miles that would need special consideration (and possibly require additional interchanges or crossovers) if the section of freeway is converted to one-way operation.

Provision of U-turn lanes at major interchanges should be considered where the cross road is at-grade and where the U-turning volume exceeds 1,000 vehicles per day for the related counterclockwise one-way frontage road flow. These turnaround lanes save about 22 seconds on the average per vehicle using the facility during the peak hours. However, many rural interchanges are not at-grade and, consequently, the provision of U-turn lanes will probably not be cost-effective.

Signalization

The presence of traffic signals at interchanges along the freeway is an important cue to the probable level that traffic volumes have attained. Comparisons of Tables 7, 8 and 12 reveal that traffic volume levels have probably reached Desirable conversion levels, or possibly reached even Minimum levels, if traffic signals are present at the interchanges of two-way frontage roads, depending on what MUTCD warranting condition was used to justify the signal installation. Moreover, the discovery that a signal is warranted is also strong evidence that either Desirable or Minimum conditions exist for conversion to one-way operation. Appropriate responses to this finding should be taken.

## CASE STUDIES AND APPLICATION OF WARRANTS

A number of Texas cities have had relevant experiences with two-way frontage roads. The following case studies are included to illustrate some of these experiences in freeway - frontage road corridors. In addition, an example of the use of the Average Daily Volume Warrant is included.

### ABILENE'S EXPERIENCE

An interesting and illuminating case study of converting two-way frontage roads to one-way is found in the experience of Abilene. The various freeways through Abilene roughly form a ring around the city; newer growth in the southwest quadrant has jumped the ring. At the time the 1979 Texas law went into effect requiring frontage road vehicles to yield to ramp traffic, Abilene's freeway frontage roads were two-way.

The City of Abilene Traffic and Transportation Department furnished information to the research team which documents the chain of events. According to these documents, a thorough frontage road study by the Traffic and Transportation Department investigated the following:

1. traffic volumes and capacities,
2. traffic circulation patterns, and
3. traffic accidents.

The report concluded that the frontage roads in the faster growing, heavier traffic areas on the southwest side of the city should be converted to one-way for reasons of both safety and intersection capacity. The report also pointed out the pros and cons of having frontage roads in some parts of the city one-way and other parts two-way.

The report included some interesting observations, such as the following:

"...traffic growth on the frontage roads is influenced to a greater extent by adjacent development than by normal traffic growth itself..."

"If Abilene's frontage roads had been one-way from the start, subsequent development would likely have provided a better peripheral street system... To minimize the inconvenience which one-way operation may cause in some areas, the transportation planning process should foster the development of a street system which will provide better access to those locations which now have access only via the frontage roads."

As the City considered conversion, the Abilene Chamber of Commerce took the stand that access roads along the freeway should be one-way for safety reasons. City Council minutes contain condensed comments of supporters and opponents of conversion to one-way. Some residents and business owners opposed the conversion because it would make it more difficult to travel (increased indirection). Some, including a business owner and the manager of a shopping mall, supported the change for safety reasons. The need for better alternate routes and more ramps was mentioned. In all, twelve citizens presented their views, with most opposed to conversion. The City Council passed a resolution asking the State to convert a substantial portion of the frontage road system to one-way.

One bit of fallout from the conversion to one-way operation occurred at an alley which became a short-cut in the absence of an adequate back-up street system. One traffic count on this unpaved, 1,000-foot long alley showed about one vehicle per minute for two hours during the two-hour afternoon rush. Another six-hour count (a.m., noon, p.m.) found over 500 vehicles using one part of the alley.

## **A RESIDENTIAL DEVELOPMENT CASE**

Figure 15 shows an example of a residential development in New Braunfels which is highly dependent upon two-way frontage road operation for easy access. Conversion to one-way traffic will result in increased circuitry of travel. Furthermore, the portion of the frontage road under I-35 is subject to some flooding and is closed on some occasions, although infrequently. With one-way frontage roads, such flooding would effectively deny ingress to the area. The provision of single access to the subdivision is an extremely poor design in any case; providing only one access point off of a freeway frontage road has the potential to inconvenience the residents.

Situations such as this are best addressed by preventing them from happening in the first place. The planning and zoning actions of a city should consider the potential access problems before approving such developments in a freeway corridor. It is much more difficult (and costly) to remedy such situations than it is to prevent them from occurring.

## **STUDIES OF EFFECTS ON BUSINESS**

Business interests can be expected to be among those most opposed to a change from two-way to one-way frontage road operation. The attitude survey (Research Report 402-1) found that most respondents believe that a business located downstream of an off-ramp and upstream from an on-ramp would not be hurt by change from two-way to one-way operations. The vast majority of real estate persons, developers, and appraisers indicated this opinion. Persons having businesses on frontage roads were the only group of which a majority believed businesses would be hurt. However, a majority of all respondent groups indicated that a business located upstream from an off-ramp or downstream from an on-ramp would be hurt by conversion of the frontage road to one-way operation.

If a business fails shortly after a frontage road is changed from two-way to one-way operation, the change in operation is likely to be claimed to be the cause. However, businesses located along two-way frontage roads are also observed to fail or relocate. The following examples presented in Figures 16 thru 20 are a few of the failed or relocated businesses on two-way frontage roads encountered during travel on this research project.

## **SH 6 BYPASS CASE STUDY**

The State Highway 6 Bypass (East Bypass) in Bryan/College Station is an example of the dependence on two-way frontage roads on the part of local

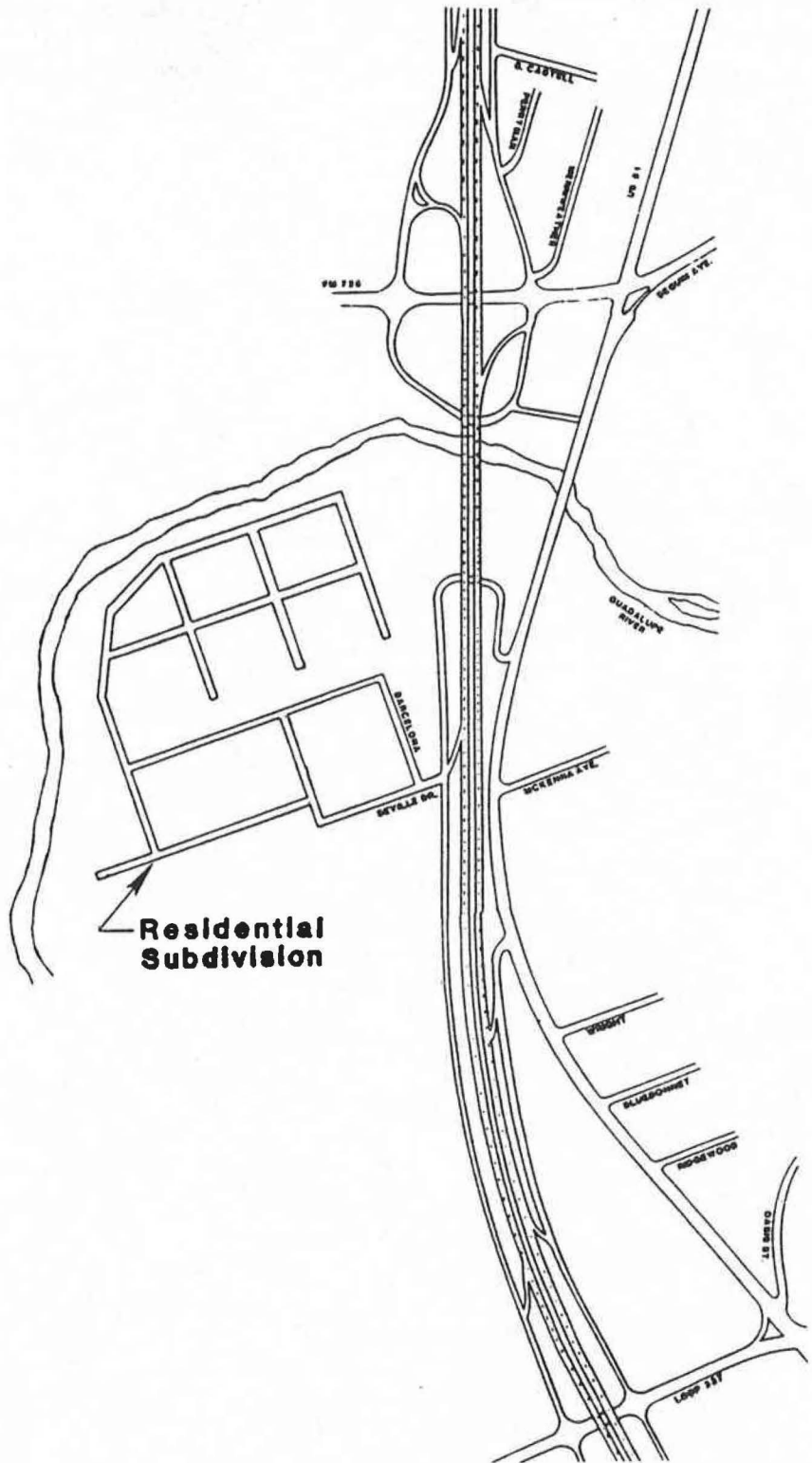

**EXAMPLE OF URBAN LAND USE WHICH DEVELOPED  
DEPENDENT ON TWO-WAY FRONTAGE ROAD**

**FIGURE 15**

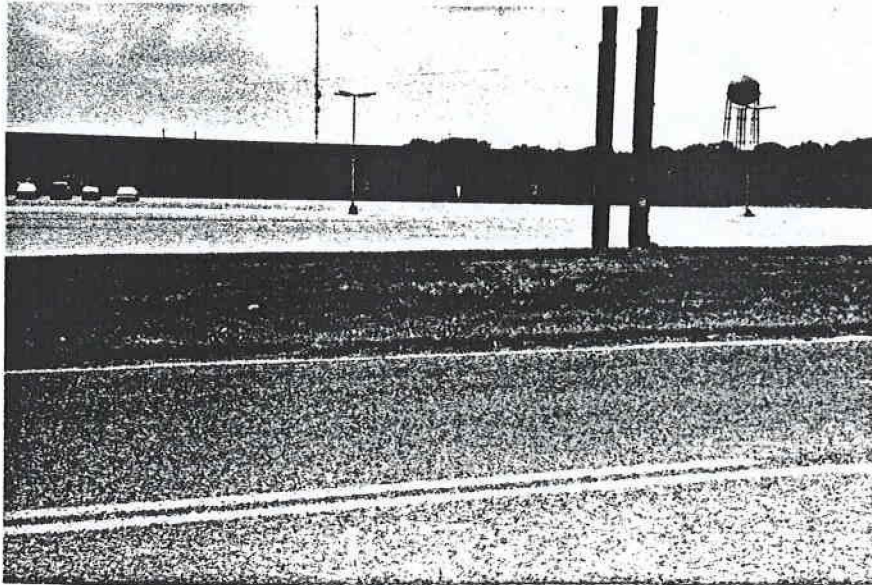

This small retail center is located on the frontage road of SH 6 Bypass at Navasota. A variety store located in the center failed; a supermarket occupies the south end of the structure.

**FAILED BUSINESS ESTABLISHMENT LOCATED ON  
TWO-WAY FRONTAGE ROAD IN NAVASOTA**

**FIGURE 16**

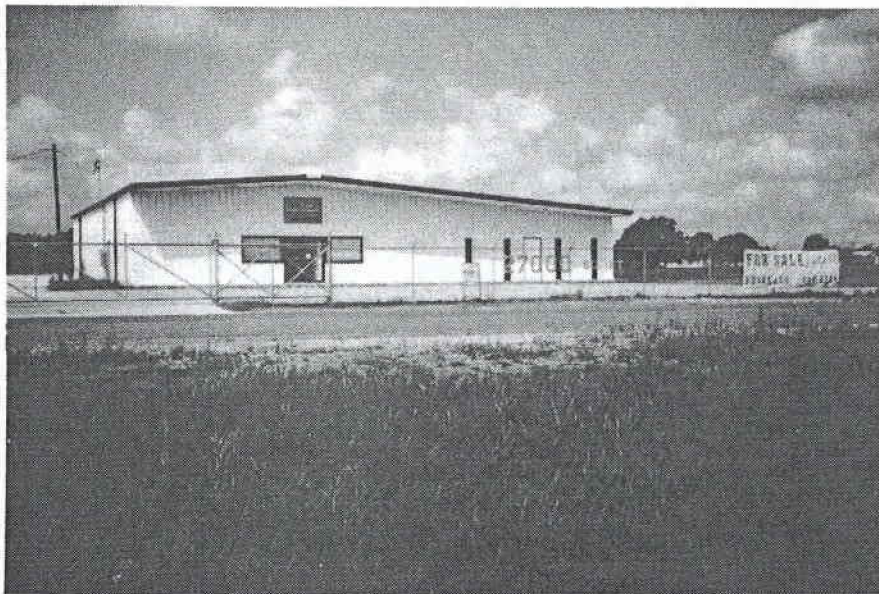

The SH 6 Bypass in Bryan is the location of this industrial establishment which failed.

**FAILED BUSINESS ESTABLISHMENT LOCATED ON  
TWO-WAY FRONTAGE ROAD IN BRYAN**

**FIGURE 17**



This service station was located on the east side of I-35 in New Braunfels. The site is located on a two-way frontage road and it is downstream from an off-ramp.

**FAILED BUSINESS ESTABLISHMENT LOCATED ON  
TWO-WAY FRONTAGE ROAD IN NEW BRAUNFELS**

**FIGURE 18**



An automobile dealer ceased business at this location along I-45 in Ferris. It appears that the site has been alternately vacant and occupied by other businesses.

**CEASED BUSINESS ALONG TWO-WAY FRONTAGE ROAD IN FERRIS**

**FIGURE 19**

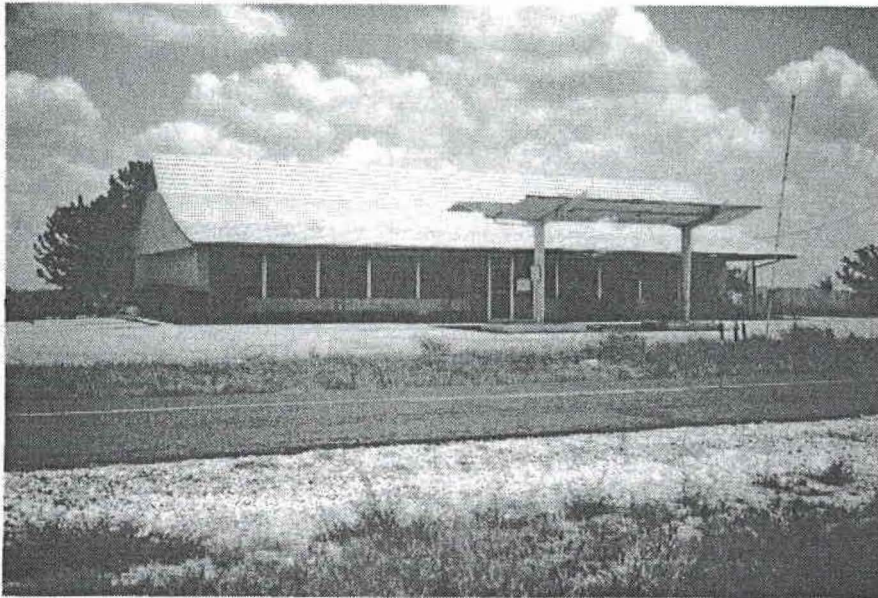

This site is located on the east side frontage road along I-45 at Rice. It is immediately downstream from an off-ramp. A change in the travelling public's preferences, not a change in frontage road operation, lead to the failure of this and similar establishments. As of August 1986, the frontage road is still two-way.

**FAILED BUSINESS ESTABLISHMENT LOCATED ON  
TWO-WAY FRONTAGE ROAD IN RICE**

**FIGURE 20**

developers and citizens. (It also will serve as an illustration of the use of the Average Daily Volume Warrants.) The East Bypass is a freeway with two-way frontage roads. It was constructed on a new location and was in close proximity to existing development at two points in College Station and one area in Bryan when opened in about 1972.

The comprehensive plan for the City of College Station recognized that the construction of the bypass opened the area east of the East Bypass and south of SH 30 for development. Consequently, the city plan anticipated a minor arterial facility to the east of and parallel to the bypass. Various updates and revisions to the comprehensive plan retained this proposed facility. Sections of this street, Appomattox Drive, were constructed as part of the Windwood, Raintree, and Emerald Forest subdivisions (see Figure 21).

It was also recognized by the city staff and the Planning and Zoning Commission that it would be extremely desirable to have a grade separation (crossover only) to connect Southwest Parkway to Appomattox in the Raintree subdivision. This would allow traffic to move to and from the area east of the bypass and the other areas of College Station and Texas A&M University without passing through one of the interchanges (principally SH 30).

These issues were raised at the time the preliminary plat of the proposed Raintree subdivision was submitted, since a change in the proposed plat would greatly facilitate construction of an overpass at a later date. It was also suggested that no lots should have direct access to Appomattox in view of the traffic volumes and speeds which could ultimately be expected. These suggestions were not incorporated into the design. It was the view of some of the Planning and Zoning board members that the failure to incorporate these changes was at least partly due to the fact that the existing frontage roads were two-way.

In recent years, considerable opposition to the completion of Appomattox has developed - especially on the part of the Windwood and Raintree residents. Increased delay at the frontage road intersections with SH 30 has resulted in substantial public pressure for an interchange at Southwest Parkway. However, construction of an interchange, rather than a grade separation only, will result in new ramps in close proximity to the existing ramps at SH 30. Consequently, the operational areas will overlap and produce weaving conflicts in the through lanes, thereby reducing the functionality of the freeway.

In interviews conducted as part of this research project, the College Station mayor and city council members, as well as the developer, indicated that they feel the Appomattox controversy would not have evolved if the frontage roads had not been two-way. This case is an excellent example of how a minority can effectively "veto" an improvement, even one included in the local comprehensive plan for the city.

## **APPLICATION OF WARRANTS**

The peak-hour warrant to convert two-way frontage roads to one-way is based on the use of PASSER II to evaluate intersection operations. If the needed detailed input data for PASSER II are not available, then the Average Daily Volume Warrant should be used. The following example employs the Bryan/College Station SH 6 Bypass to illustrate use of the ADT warrant.



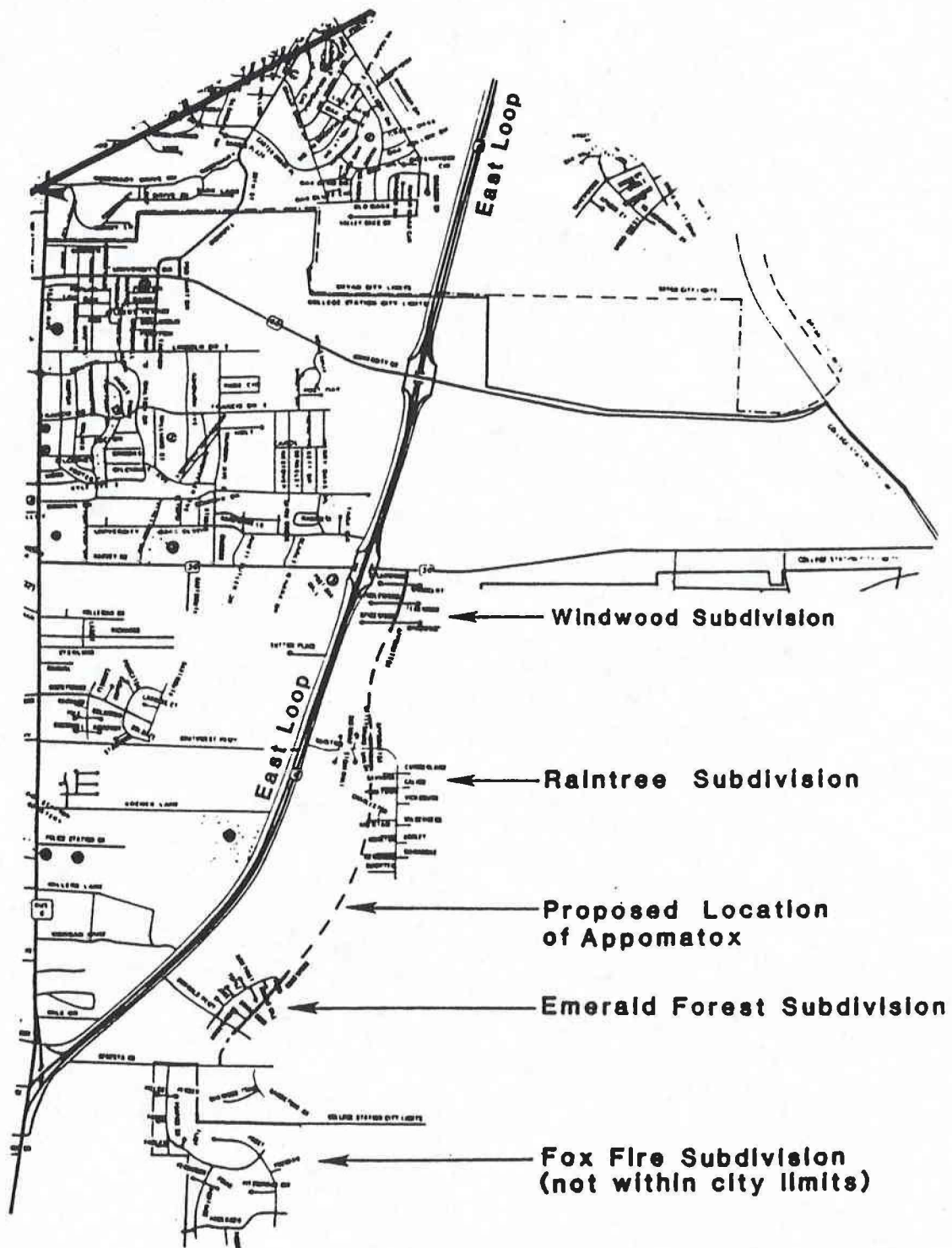

LOCATION OF APPOMATTOX DRIVE, COLLEGE STATION

FIGURE 21

Two-way continuous frontage roads were provided with the bypass when the facility was constructed 16 years ago. The areas' population was growing at 6 percent per year. Since the time of construction, significant development has occurred outside of the bypass, including residential subdivisions and large employment centers. Most commercial businesses are situated at the cross road corners. Informational signing has stated for several years that frontage road operations are temporarily two-way. Traffic signals have been recently installed at 5 of the 8 diamond interchanges along the bypass. The two directional interchanges at the north and south terminals of the bypass do not have signals. A modest amount of local street circulation is available inside the loop; practically no convenient contraflow circulation is available outside the loop. Traffic congestion is observed during the peak hours at several of the interchanges, even since they have been signalized.

PASSER II - 87 is not yet available and its data collection requirements would be significant for a study of this size. However, summaries of the total ADT traffic entering each interchange during a typical weekday together with interchange type and spacing between interchanges are available. Figure 22 shows a map of the area with existing interchanges, crossovers, and proposed interchanges.

Table 12 presents the pertinent input data to the warrant process. The last two columns of Table 12 provide the results of calculations of the ratios of total entering ADT as a percent of Minimum Acceptable and Desirable warranting volumes. All five of the signalized locations satisfy the Desirable Warrants (the ratio of the current volume to warrant volume exceeds 100%). One of the five satisfies the Minimum Acceptable Warrant; three of the others are within 10% of the Minimum Acceptable Warrant Volume.

**TABLE 12**  
**APPLICATION OF ADT CONVERSION WARRANTS TO A**  
**BYPASS AROUND BRYAN/COLLEGE STATION**

Sequence Numbers	Interchange Characteristics		Separation Distance (Feet)	Total Entering ADT	Percent of Warrant Value	
	No. Type (Table 11)	Signalized (Y,N)			Desirable	Minimum
1	c	N	--	c	--	--
2	1	N	8,976	a	--	--
3	1	N	3,960	17,200	86	69
4	3	Y	6,660	31,200	104	83
5	1	N	3,960	b	--	--
6	1	Y	6,660	23,500	118	94
7	3	Y	4,224	40,100	134	107
8	2	Y	9,504	34,700	126	99
9	4	Y	4,224	38,800	111	91
10	c	N	13,992	c	--	--

- a Light traffic; interchange is not signalized.
- b Light traffic; crossover is not signalized.
- c Directional wye interchange; it is not signalized.

The relatively long spacings between interchanges #1 (the north wye) and #2 and between #9 and #10 (south wye) present situations which could be

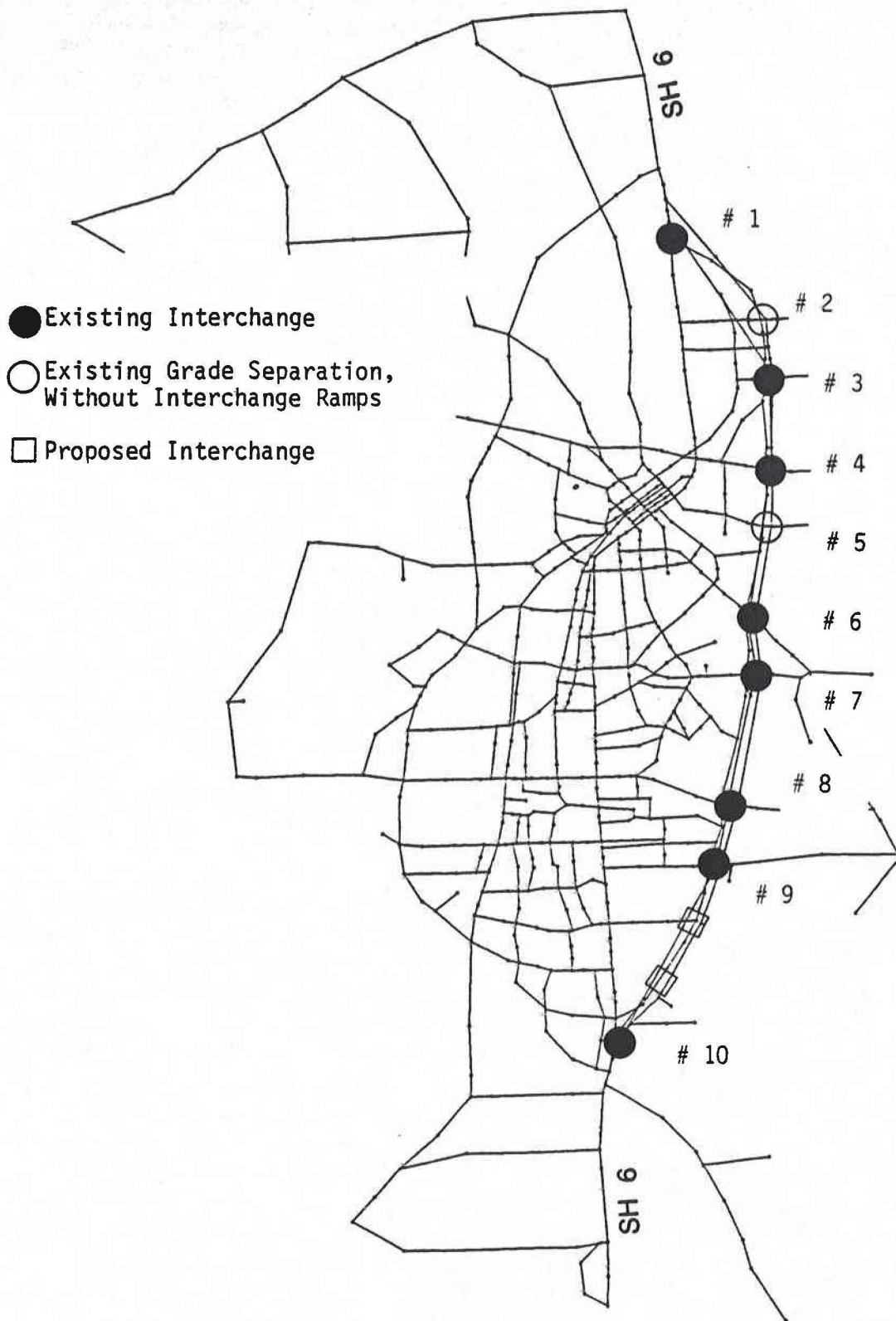

EXISTING AND PROPOSED INTERCHANGES ON STATE HIGHWAY 6.  
COLLEGE STATION/BRYAN

FIGURE 22

considered unfavorable to conversion to one-way frontage road operation. However, the development pattern at the north end (between interchanges #1 and #2) is such that there will be little impact on travel patterns. The addition of the two new interchanges between the existing interchange at State Highway 30 (#9) and the south wye (#10) will ameliorate the impact of one-way frontage roads. The travel time between most points will be about the same as at present with two-way frontage road operation if Appomatox Drive is completed. In some instances it will actually decrease, largely due to reduced delay at the signalized intersections of the cross-street and the frontage roads.

Interchange 5 located midway within the freeway corridor is a crossover structure without entry or exit ramps to the freeway. Therefore, the effective separation distance between interchanges will vary depending on the type of trip and location of destination along the freeway. For Type 1 trips, the same-side local-local trips, effective spacings are as given in Table 12. For Type 3 trips, spacings are as given in the table for destination up to the crossover; beyond it, effective spacings are the equivalent of the total distance back to the upstream cross road interchanging, a total of 10,620 feet between the normal interchanges 4 and 6. It is observed that this wide separation distance between crossovers is not conducive to business development (a "poor" condition). No business currently occupies this section of freeway. Since there currently are no trips of this type with two-way operations, no negative impacts would arise. The proposed conversion of the existing crossover to interchange status by providing ramps would certainly help freeway accessibility but would not provide any significant benefit to any circuitry problems that might arise due to conversion since none presently exist there.

## REFERENCES

1. Woods, Donald L. and M.S. Chang. "Accident Analysis of the Conversion from Two-Way to One-way Frontage Road Operation", Research Report 288-3. Texas Transportation Institute, Texas A&M University, College Station, TX. November 1983.
2. Stover, V.G., J.L. Gattis, and C.J. Messer. "Attitudes Concerning Two-Way and One-Way Frontage Roads." Research Report 402-1, Texas Transportation Institute, August 1987.
3. Adkins, W. G. "Effects of the Dallas Central Expressway on Land Values and Land Use." Bulletin 6, Texas Transportation Institute, September 1957.
4. Franklin, W. D. and L. A. Evans. "Effects of Access on Highway Right-of-Way Costs and the Determination of Special Benefits." Research Report 82-1F. Texas Transportation Institute, October 1968.
5. Stover, V. G., W. G. Adkins, and J. C. Goodknight. "Guidelines for Median and Marginal Access Control on Major Roadway." NCHRP Report 93. Highway Research Board, 1970.
6. Buffington, J.L., C. W. Herndon, and M. E. Weiss. "Non-user Impacts of Different Highway Designs As Measured by Land Use and Land Value Changes." Research Report 225-2, Texas Transportation Institute, March 1978.
7. Woods, D. L. "Freeway Frontage Road Operations and Safety Study." Research Report 288-4F, Texas Transportation Institute, March 1984.
8. Gattis, J.L., C.J. Messer, and V.G. Stover. "Delay to Frontage Road Vehicles at Intersections with Ramps." Research Report 402-2, Texas Transportation Institute, December 1987.
9. "Highway Capacity Manual." Special Report 209, Transportation Research Board, Washington, D.C., 1985.
10. "Manual on Uniform Traffic Control Devices." Federal Highway Administration, Washington, D.C., 1978.

