

SOME CONSIDERATIONS OF VEHICULAR DENSITY  
ON URBAN FREEWAYS

by

John J. Haynes  
Professor and Head of the Civil Engineering Department  
Arlington State College - Arlington, Texas  
(Formerly Assistant Research Engineer - Texas)  
Transportation Institute - Texas A&M University)

Research Report Number 24-6

Freeway Surveillance and Control  
Research Project Number 2-8-61-24

Sponsored by

The Texas Highway Department  
In Cooperation with the  
U. S. Department of Commerce, Bureau of Public Roads

April, 1965

TEXAS TRANSPORTATION INSTITUTE  
Texas A&M University  
College Station, Texas

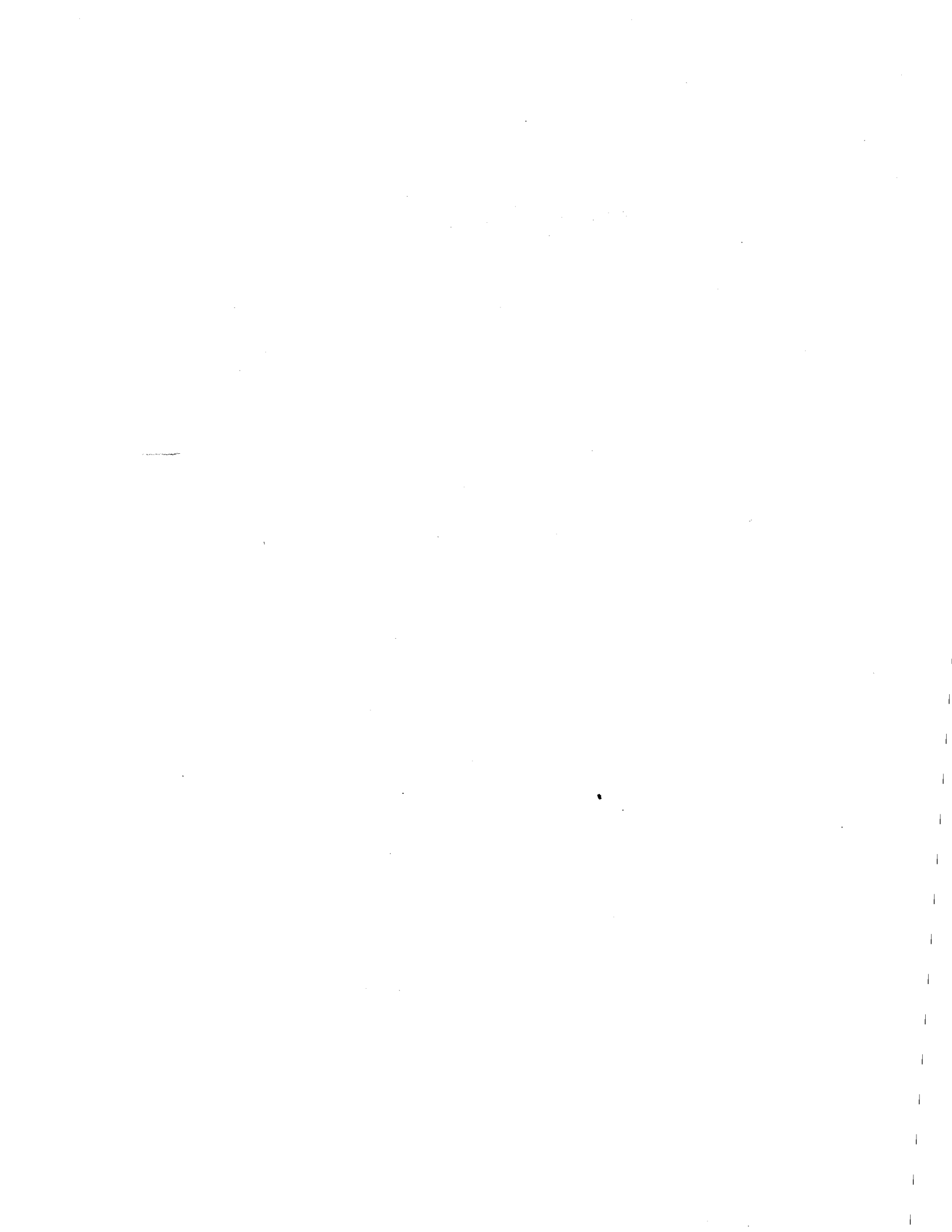

## TABLE OF CONTENTS

|  | <u>Page</u> |
|--|-------------|
| I. INTRODUCTION  | 1           |
| General  | 1           |
| Scope  | 6           |
| II. DENSITY SENSING EQUIPMENT                              | 8           |
| Review of Current Methods                                  | 8           |
| Present Limitations  | 10          |
| Some Desirable Features                                    | 11          |
| III. AERIAL PHOTOGRAPHY STUDY METHODS                      | 17          |
| The Houston Aerial Photography Study                       | 17          |
| Data Reduction   | 18          |
| Density-Volume Relationship                                | 21          |
| IV. DENSITY TRAP STUDY METHOD                              | 27          |
| General Concepts   | 27          |
| Method Description   | 28          |
| V. ANALYSIS OF DENSITY DATA                                | 38          |
| Density Data Concept                                       | 38          |
| Density-Volume Relationship                                | 39          |
| The Variability of Concentration                           | 42          |
| VI. SELECTION OF LENGTHS AND LOCATIONS FOR DENSITY SENSING | 48          |
| Locations of Critical or Bottleneck Sections               | 48          |
| Considerations of Density Sensing Section Lengths          | 50          |
| VII. CONCLUSIONS AND RECOMMENDATIONS                       | 53          |
| Conclusions  | 53          |
| Recommendations  | 55          |
| APPENDIX   | 58          |
| REFERENCES   | 60          |



## LIST OF FIGURES

|  | <u>Page</u> |
|--|-------------|
| 1. The Speed-Volume-Density Surface  | 4           |
| 2. Desirable Summation Gridwork of Sensors   | 13          |
| 3. Undesirable Scheme Utilizing Difference of Counting Sums  | 13          |
| 4. Standing Wave Variation Along A Transmission Line   | 16          |
| 5. Transmission Line Circuitry Scheme  | 16          |
| 6. Typical Time-Lapse Photographs  | 19          |
| 7. Typical Continuous Strip Photograph   | 20          |
| 8. Volume-Density Relationship Obtained from Continuous Strip Aerial Photography   | 24          |
| 9. Estimated Volume Versus Actual Volumes Obtained in the Continuous Strip Aerial Photography Study                                  | 25          |
| 10. Wiring Scheme for Density Trap Apparatus   | 29          |
| 11. Filming Station for Density Trap Study   | 31          |
| 12. Manual Count Station at Edge of Freeway  | 33          |
| 13. Manual Count Station Adjacent to Bridge  | 33          |
| 14. Volume Rates In and Out of a Density Trap  | 38          |
| 15. Volume-Density Relationship Obtained From Density Trap Studies   | 41          |
| 16. Concentration Distributions Obtained From Density Trap Studies   | 45          |
| 17. Density Contours (Three-Lane Total)  | 49          |
| 18. Relationship Between the Standard Deviation Per Cent of the Mean Concentration and the Length of Sensing Section at High Volumes | 52          |



LIST OF TABLES

|   | <u>Page</u> |
|---|-------------|
| 1. Continuous Strip Aerial Photography Density Study<br>Tabulation          | 23          |
| 2. Summary of Density Trap Study Method Runs in<br>Houston                  | 36          |
| 3. Density Trap Study Method Travel Time and Space<br>Mean Speed Tabulation | 40          |
| 4. Standard Deviations Obtained in Density Trap Studies                     | 47          |





INTRODUCTIONGENERAL

A widespread urban freeway problem is that of the overcrowding or congestion which results from the peak traffic demands. The work traffic is customarily associated with the peak demand such that for a short time each weekday morning and afternoon many urban freeway sections offer a poor level of service to the motorists.

Although control of freeway traffic is, in itself, an anomaly, it has become increasingly apparent that some regulation or control of the traffic during such critical periods is necessary. Investigations are being made of the effect of metering or restricting input to freeways and speed advisory signs for the traffic on the freeways are being used and evaluated.

Whatever the control action may be, there is a need for practical, reliable, and efficient information which will actuate or initiate the control measure or measures. Control systems will consist of an input sensor component which will supply the necessary information, a logic component which will translate input information into a course of action and a control component which will enforce the chosen course of action. An iterative series of the foregoing phases will continuously sample, decide, and act throughout a period when control may be necessary.

Surveillance systems combine the first and part of the second compo-

nents of a control system. Surveillance systems can be thought of as preludes to control systems. A television surveillance system uses television cameras and pictures as the sensor component and human beings as the logic component. Traffic stream element detector systems are also used as surveillance devices. Electronic vehicle detectors and speed detectors are used in typical element detector systems as the sensing components and analogue electrical circuitry is used as a part of the logic component.

Although traffic stream element surveillance systems have the obvious limitation of not presenting the whole "picture" of the traffic situation they are more susceptible to adaptation to an automatic control system. Up until the present time, only the time based elements of the traffic stream have been utilized, or sensed, by these element systems, namely, volume (in vehicles per hour) and/or speed (in miles per hour). It is possible with some of the systems to measure the percent occupancy which is related to density but is a point obtained value and must be based on a time interval.

In the general traffic stream equation  $q = kv$ ,  $q$  is the flow (or volume) in vehicles per unit of time,  $v$  is the space mean speed of the vehicles in the traffic stream in distance per unit of time, and  $k$  is the concentration (or density) of vehicles in a length of roadway in vehicles per unit of length. If any two of these three traffic stream elements are known, the

third is uniquely determined. Density, or concentration, has generally been considered the dependent element because the other two elements have been the measured elements. There is, however, no single dependent element but only a relationship between the elements. It is helpful in visualizing the basic traffic stream equation to consider the surface which represents the equation when plotted on mutually perpendicular axes, as shown in Figure 1. The locus of all possible points is a surface which is infinite in extent; however, there are practical limitations which have been rather well established by many previous studies.

Congestion is a qualitative term which is used in traffic engineering to indicate a condition of traffic and traffic movement. Density is the quantitative measure of congestion and thus should be the most desirable element to use in freeway operation control. High volumes of traffic or high average speeds are not objectionable from an operational standpoint. Actually, high volumes and speeds are desirable in themselves, but it is known that sustained high volumes can lead to lower speeds and hence high densities, or concentrations of vehicles on the roadway, which are undesirable. Unfortunately, continuous densities have not been directly measurable. Volumes and speeds have been measured for many years by a variety of means.

Some of the factors which influence the interrelationship of density, volume, and speed are the methods of measuring each. Density is, by

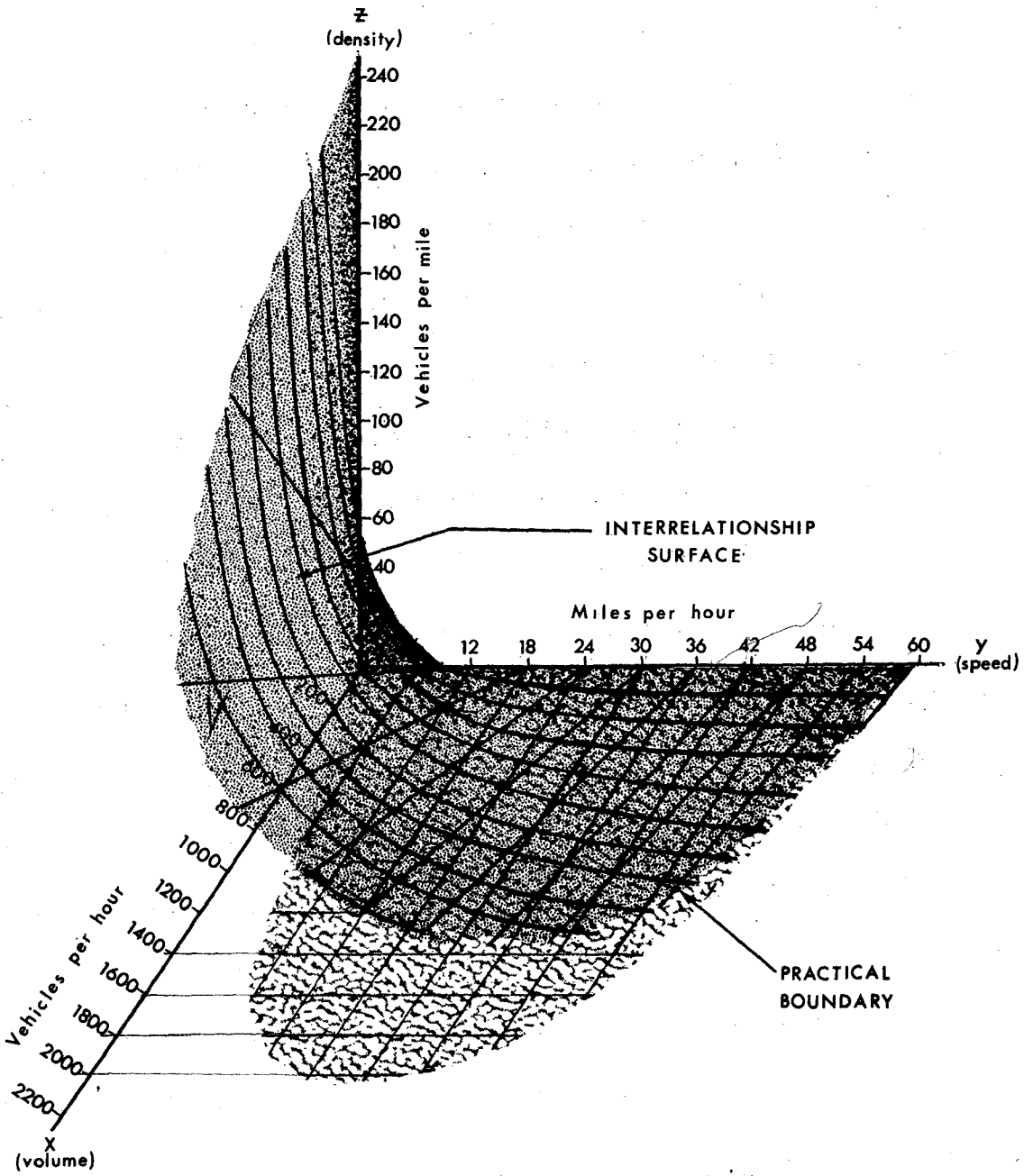

Figure 1. The Speed - Volume - Density Surface (One Lane)

its very nature, a space element of the traffic stream; volume is a time-point (nonspatial) element; speeds are sometimes point elements (spot speeds or instantaneous speeds) or are sometimes based on travel times over a finite, short distance (space mean speeds). Sensing devices have been used to determine speeds and volumes at a point (1)\* (or over a very limited length of roadway), and densities have been rapidly approximated at short time intervals, by electronic means, on the basis of such point information. This process, in effect, extrapolates speed and volume information obtained at a point to density over a distance of up to a mile. Density fluctuates continuously and it becomes critically high in certain spaces on a freeway in connection with the creation of bottlenecks. Investigations at Texas A&M University by Keese, Pinnell, and McCasland (2) have shown that traffic in the near vicinity of entrance ramps becomes congested enough to reduce speeds as much as 50 per cent or more during regular peak flow periods. From the fundamental relationship:  $q = k \mu$  Volume is equal to density times speed, it is obvious that if a given volume of vehicles slows down, the density must increase, resulting in more congestion.

It would be desirable to sense density directly over a given length of roadway. From a control standpoint, it is hypothesized that density

\* Numbers in parentheses refer to references at the end of the text.

sensing offers greater promise than the current methods of computing density on the basis of speed and volume information.

If by some satisfactory means density were sensed, there would remain the problem of determining the proper selected locations of sensors, the required lengths of roadway to be sensed for density, and the critical density values to be used for the controlled operation of freeway traffic. It is necessary that the characteristics of density be carefully studied by itself prior to its utilization as a control element. Because density has been the dependent or calculated element heretofore, little has been developed which would enable the study of the basic nature of density.

### SCOPE

This report includes parts of a general study of the various aspects of vehicular density for use in the control of freeway traffic (3). Density is herein considered singly as a possible control element of a freeway operational system. This study provides information which may be useful for freeway control methods. Electronic equipment manufacturers should be encouraged by this study to develop density sensing systems.

The scope of this report specifically involves principal study areas described as follows:

1. The principal features of existing methods used to measure or estimate density are reviewed. There are two basic methods

involved. One is a process in which density is estimated on the basis of speeds and volumes which are sensed at a point. The other method, which is not yet operational, involves the actual measurement of the density, or concentration of vehicles in a space. The undesirable features and limitations of existing equipment are listed, and the general features which are desirable in density sensors are described.

2. Results of aerial photography studies of the Gulf Freeway in Houston, Texas, are utilized to show how density may be related to volume as well as to certain geometric features of the freeway facility.
3. A field study method is described which yields continuous values of vehicular concentration on certain sections of a freeway. The results of several of these density-trap studies are analyzed for the purpose of determining the variability and frequency distributions of freeway concentration and relating the length of sensing sections to the variability of concentration.
4. The analysis of the data demonstrates a means of establishing optimum, or critical, freeway concentration values and provides a means of identifying critical, or bottleneck, sections at a freeway which exhibit recurring high densities.





## II

### DENSITY SENSING EQUIPMENT

#### REVIEW OF CURRENT METHODS

There are presently several different firms which supply electronic density computers. General Railway Signal Company of New York and Automatic Signal Division of Connecticut have developed such systems. Actually, the systems available at the present time are capable of measuring both speeds and volumes; density is computed on the basis of these values.

The computers utilized in density computations usually generate analogue functions which may be recorded as analog data, displayed on output meters, or used in connection with control systems. The input information which is necessary for density computation by a computer requires time to accumulate. The passage of a number of vehicles or the time passage of several seconds or minutes is necessary in order for the traffic stream to generate data to be evaluated.

The electronic circuitry involved in existing traffic surveillance analogue computers is beyond the scope of this study. It is possible, according to some of the manufacturers, to modify or adjust the output of such systems for a wide variety of purposes. A preselected time period has been mentioned as a necessary constant for computing volumes and average speeds. In many instances, manufacturers will offer several

different time intervals which may be used.

An altogether different type of density sensing is being developed in England by the Road Research Laboratories. Charlesworth, Head of the Traffic Section of the Laboratories, replied to this author's inquiry about the actual sensing of vehicles in a space, rather than computing the concentration on the basis of speed and volume. In the reply, it was stated that there had been a development of such a system which "measured the number of vehicles in the area adjacent to a large loop detector." It was stated that the detector produced an output dependent upon the number of vehicles adjacent to its detector loop and has been used to determine when the "level of traffic" in a traffic circle exceeded a critical value. It was further stated that this instrument would be commercially available in the "near future."

The detector loop referred to in connection with the instrumentation in England is a known and utilized device in this country. Vehicle presence detectors which operate with loops installed just below the pavement surface are used at toll gates, traffic signals, etc.

These vehicle detectors, however, are used only to detect the presence or absence of a single vehicle adjacent to (just above) the loop. The output is a two-step function only, indicating an event is, or is not, occurring. The development of the loop detectors to indicate the number of vehicles adjacent to a large loop (1000 feet or more in perimeter) would

involve an analogue function output which would be indicative of the number of vehicles. In this sense, the Road Research Laboratory is developing a true density (or concentration) sensor rather than a density computer.

#### PRESENT LIMITATIONS

The density (or occupancy) computers now available involve the limitations of point sensing and time lag which are not actually limitations of the density element, but are imposed by the means which are now utilized in the computer-sensor scheme. As stated in the earlier part of this chapter, density is not presently sensed by available equipment; it is computed on the basis of volume and speeds, both of which are time dependent elements of the traffic stream and must be measured at a point on a facility. The information obtained at a point is then extended such that, assuming unchanging conditions exist downstream from the point, a density or concentration of vehicles is estimated on the basis of a required, preselected time interval.

Density is a function of vehicles and roadway length only; time is not a dimension of this element. Density exists continuously at all instants in time. It is the one element which can be obtained at any instant without counting for a predetermined time interval and thus would be more readily available for control decisions.

Conditions do change from section to section along a freeway and

conditions at one point do not accurately predict or represent conditions at all other adjacent points. Density is more nearly related to congestion and it should be sensed directly in order to accurately measure congestion. The devices now in use only predict, with limiting assumptions, what the density might be downstream, and only then after an arbitrary time period of counting.

It would seem that improved methods are forthcoming and that true density sensing will be done in the future.

#### SOME DESIRABLE FEATURES

Economy is a feature to be desired in a density sensing device. Methods are now possible which are too costly to consider. In order to utilize density as an element of control information, it must be economically feasible to sense it. A determination of the economic justification of density sensing or the benefit-cost ratio of traffic surveillance systems is perhaps difficult at the present time. It is presumed that in the developmental stages some research and traffic surveying systems are not immediately economical but may result in long-term savings in terms of lives, dollars, time, and information. It remains, however, to develop an economical means of sensing density.

The systems developed should, of course, be density sensors (or concentration sensors), and not concentration computers or estimators. Such systems would desirably be highly reliable. As in any automated

device, it would be desirable to incorporate "fail safe" features or positive indications when the system was out of order.

The scheme of operation of a density sensor should be such that the failure of one component or sub-part would not create an accumulative error in the output of the system. Schemes involving a continuous counting routine are typical of those which would accumulate an error if one counting element failed. More specifically, it would be more desirable to feed the continuous output of a gridwork of vehicle detectors into one total output such as that shown in Figure 2 than to periodically deduct the "out" detector sums from the "in" detector sums in an arrangement similar to that shown in Figure 3. The failure of one sensor in the gridwork scheme would cause a small non-accumulative error in the output, whereas the failure of one sensor in the scheme of counting, shown in Figure 3, would result in an ever-increasing error as time progressed. An additional feature of the desirable system shown in Figure 2 is that it requires no starting technique. It would yield continuously, from the time the sensors were activated, the concentration of vehicles within the section. The undesirable scheme shown in Figure 3 requires some special starting technique for the determination of the number of vehicles in the section at the time the counting begins.

It would be highly desirable that the density sensors be unaffected by

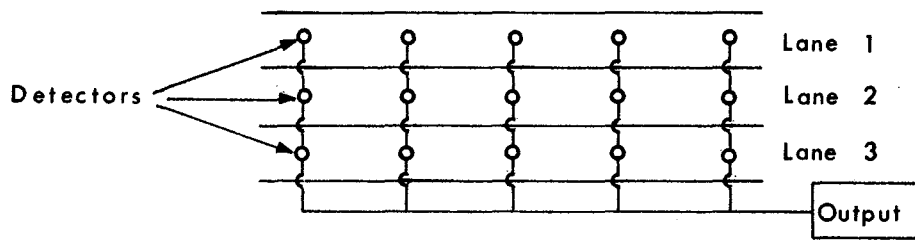

Figure 2. Desirable Summation Gridwork of Sensors

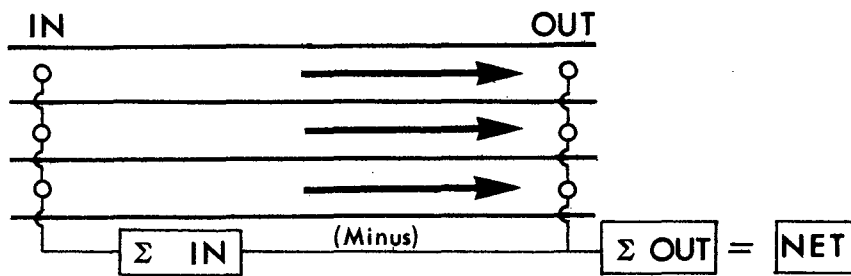

Figure 3. Undesirable Scheme Utilizing Difference of Counting Sums

the speed of the vehicle. Some vehicle detector loops and radar detectors will not operate if the vehicular speeds are below 5 miles per hour. Detector loops may cease to detect the presence of a stopped vehicle after a short period of time. The system would desirably sense vehicles at high speeds as well as those which have stopped.

If vehicles could be sensed according to lanes, the system would have more utility. It might also be desirable to let the influence of large trucks be represented in the output of the system.

A system would desirably be durable and easily installed and maintained. The utility of a density sensing device would be increased if there was a wide range of roadway lengths which could be sensed.

In a very limited experimentation program undertaken at Arlington State College, certain studies concerning the development of density sensors were made. Attempts were made to utilize low frequency electromagnetics which depend upon an electromagnetic field of a very low frequency and a magnetic detection unit. The poor isolation properties of the low frequency field resulted in unreliable detections because the flux was not controlled, or confined, to a desired region. The use of magnetometers was considered; however, a review of the cost of such a system revealed that such a method would be too expensive to investigate in this study. The method of sensing impedance shifts of a transmission line placed along the center line of a lane was investigated and proved to offer promise in a revised application.

A system which appears to be feasible because of its economy, reliability, and simple circuitry is one in which equally spaced, short transmission lines are placed at right angles to the center line of a lane. An oscillator supplies energy to the transmission line and a standing wave pattern is set up adjacent to the line. Figure 4 illustrates the relationship between the voltage and the distance along the line.

In the absence of any vehicle adjacent to the transmission line, a

voltage detector fixed at point A, Figure 4, would read some small minimum voltage. The presence of a vehicle near the line causes a shift in the standing wave pattern which would result in an increase in voltage at point A. The direction of the wave shift is of no concern because the wave pattern is symmetrical and a small shift in either direction would result in the same voltage increase.

A schematic diagram of a transmission line circuit is shown in Figure 5. The line itself is comprised of simply two ordinary parallel wires. An oscillator is used which operates in the 100 megacycles per second range and is rather inexpensive, costing about 20 dollars. The rectifier serves as an envelope detector and the output voltage is largely D. C.

Multiple detectors may be incorporated into a sensing system similar to that shown in Figure 2. The voltage outputs of each detector system can be combined to operate a voltmeter which could be calibrated to read in vehicles rather than volts.



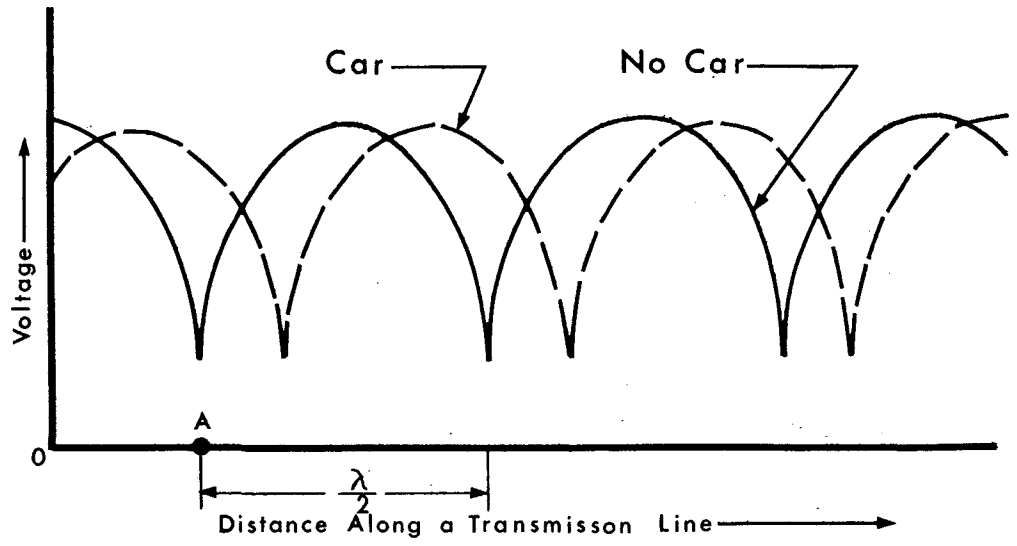

Figure 4. Standing Wave Variation Along a Transmission Line

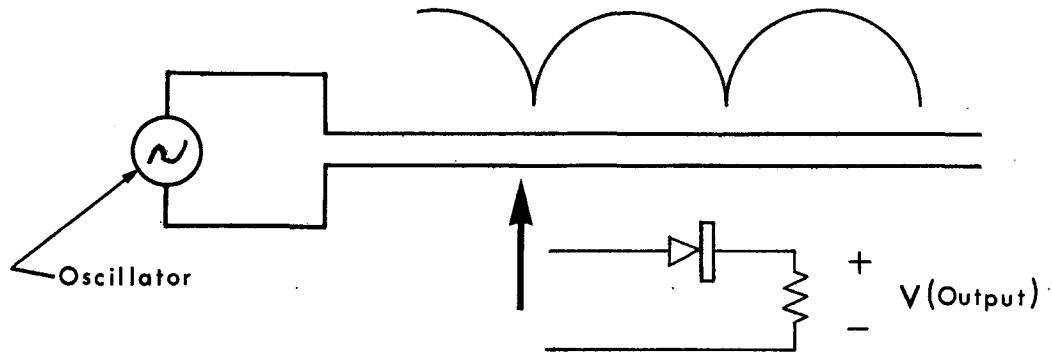

Figure 5. Transmission Line Circuitry Scheme

### III

#### AERIAL PHOTOGRAPHY STUDY METHODS

##### THE HOUSTON AERIAL PHOTOGRAPHY STUDY

In September, 1962, aerial photography studies were made of a five mile section on the Gulf Freeway (U. S. Highway 75) which extended from the edge of the central business district in Houston southeastward to the Reveille Interchange, where State Highways 225 and 36 intersect the freeway. Two methods of aerial photography were incorporated in these studies under the direction of the Texas Transportation Institute in cooperation with the Texas Highway Department and the Bureau of Public Roads. The two methods were the time-lapse and the continuous-strip.

There were two principal objectives of the aerial photography study of the Gulf Freeway. It was desired that the two aerial photographic methods be compared for their applicability to aerial traffic surveys and also considerable information concerning the operational characteristics of the freeway was expected. The work was contracted to two aerial photography firms. Each firm utilized a Cessna 195 fixed wing aircraft. Each company began flights at about 6:30 a.m. and continued until about 8:00 a.m. and the two planes were required to be separated by at least a two minute interval. The time-lapse plane was required to make nine runs and the strip-film plane was required to make as many runs as possible and furthermore, was required to repeat its schedule of runs from

6:30 a.m. until 8:00 a.m. on a subsequent morning as soon thereafter as practicable. This arrangement resulted in the nine time-lapse runs and a total of twenty-two continuous strip-film runs. The planes were requested to fly only one outbound run on the first filming day and the strip-film plane was requested to repeat this procedure on its second filming day.

During the filming runs, ground observers made volume counts at several points along the five mile section of freeway. Several control vehicles were specially marked on the roof and made runs in and out continuously during the filming sequences for which they recorded their travel times. No communication between the ground stations and the airplanes was provided for. There was a synchronization of watches one-half hour before the start of the filming flights.

Each of the twenty-two strip-film runs was developed and furnished as positive film transparencies at a scale of about 1 inch to 300 feet. The nine time-lapse film runs were developed and printed at a scale of 1 inch to 100 feet. Figures 6 and 7 illustrate, to a reduced scale, these furnished photographic types.

#### DATA REDUCTION

McCasland (4), in reporting on the data reduction techniques used on the Houston aerial photography study, emphasized that it was decided that each method and each run would be subjected to as complete a reduction

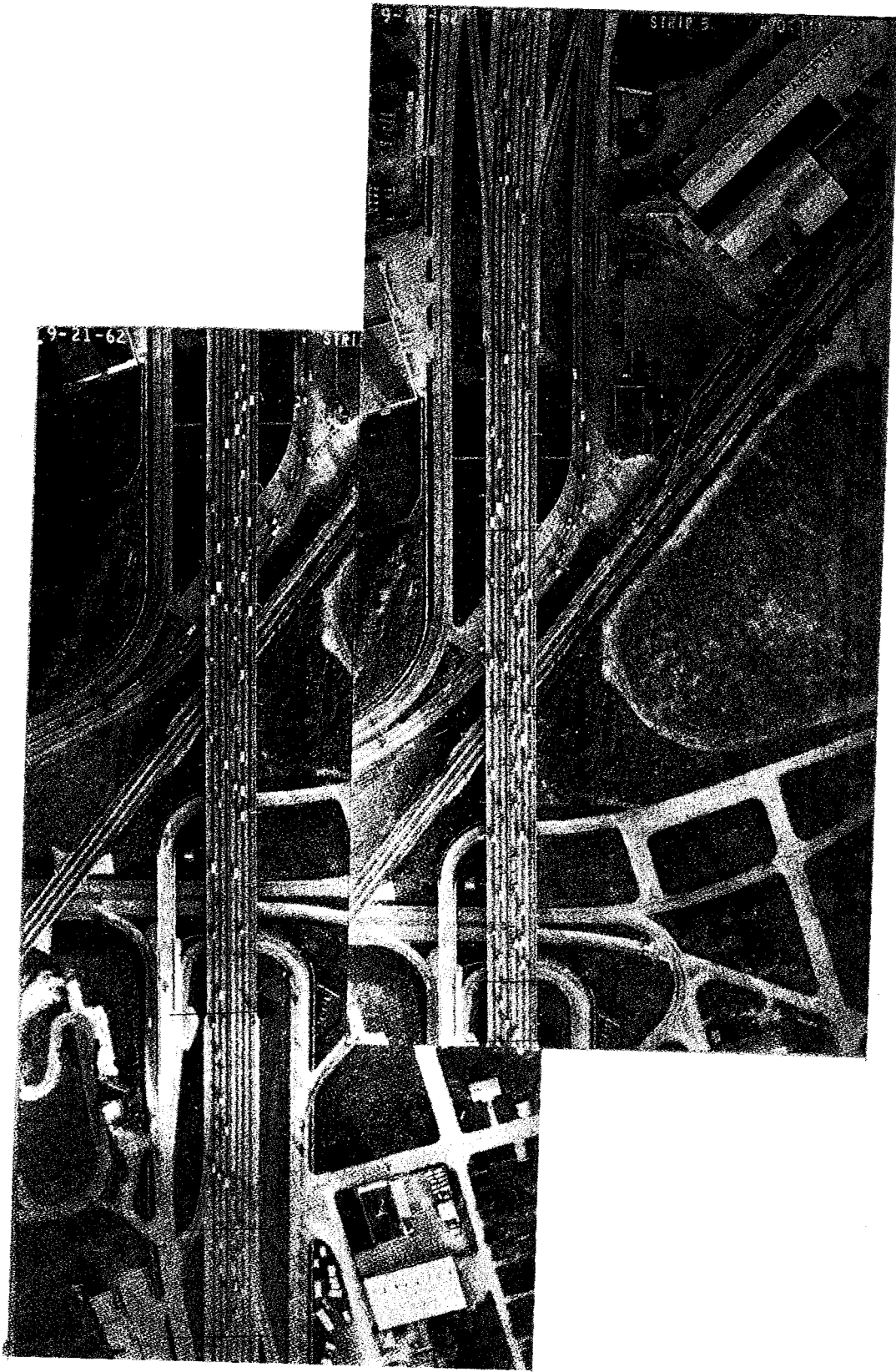

Figure 6. Typical Time-Lapse Photographs



Figure 7. Typical Continuous Strip Photograph

of data as possible. Had it been desired only to analyze the films for a particular characteristic, such as density, the total time involved could have been reduced. The basic reduction of the film data was completed in the spring of 1963 and was in a general form on punched cards which could be utilized for many different types of analysis.

#### DENSITY-VOLUME RELATIONSHIP

Since it is the volume which ideally should be kept as high as practically possible, the relationship between volume and density should be well established if density is to be used as a control element. Each freeway may exhibit a different characteristic volume-density relationship. It is furthermore likely that different sections along a freeway will have their particular volume-density characteristics. Factors which can influence this relationship are not only the geometric features of the freeway such as lane widths, grades, median widths, shoulder widths, curvature, sight distance, entrance and exit ramps, etc., but also the posted speed limits, size of the metropolitan area, and distance from the central business district, etc.

Any specific section of a particular freeway facility can be studied for the volume-density relationship. The continuous strip aerial photography described earlier was utilized to make a study of this type. A test section was selected such that no entrance or exit was possible within the section, but all vehicles entering at one end exited at the

other end or stopped within the section.

The number of vehicles within the test section was obtained for each of the 22 different flights. The speeds of the vehicles were averaged (space mean speeds) and the volumes were then computed on the basis of the density and the speeds. Table 1 is a tabulation of the 22 runs.

The 22 points obtained in this study are plotted in Figure 8, which shows the volume-density relationship for this particular study section. A curvilinear regression, using a second degree parabolic relationship, yielded the equation of best fit:

$$V = 75 D - 0.205D^2 - 812,$$

in which  $V$  = Three-lane volume (veh/hr).

and  $D$  = Three-lane density (veh/mi).

This regression analysis placed no restrictions on the constant term, thus, when the density in this equation is zero, the volume is -812. The true relationship is such that volume is zero when density is zero. The equation, however, is the best second degree curve fit for the points shown, all of which are in the volume range of 2500 to 6500 vehicles per hour.

The volumes as predicted by the equation were computed for each of the 22 densities obtained in this study and plotted versus the volumes obtained in the study, as shown in Figure 9. The coefficient of correlation for these points is 0.906 and R-square is 0.82, or it could be said that the second degree equation accounts for about 82 percent of the

TABLE 1

## Continuous Strip Aerial Photography Density Study Tabulation

| Vehicular Concentration<br>(per 2000 ft) |                         |                         |                         |              |                | Space                       |               |
|--|-------------------------|-------------------------|-------------------------|--------------|----------------|-----------------------------|---------------|
| <u>Run</u>                               | <u>Lane</u><br><u>1</u> | <u>Lane</u><br><u>2</u> | <u>Lane</u><br><u>3</u> | <u>Total</u> | <u>Density</u> | <u>Mean</u><br><u>Speed</u> | <u>Volume</u> |
| 1  | 4                       | 5                       | 8                       | 17           | 44.9           | 53.6                        | 2407          |
| 2  | 7                       | 10                      | 9                       | 26           | 68.6           | 38.3                        | 2627          |
| 3  | 9                       | 11                      | 6                       | 26           | 68.6           | 51.5                        | 3533          |
| 4  | 8                       | 10                      | 11                      | 29           | 76.6           | 50.5                        | 3868          |
| 5  | 14                      | 22                      | 18                      | 54           | 142.6          | 46.9                        | 6688          |
| 6  | 13                      | 18                      | 14                      | 45           | 118.8          | 43.3                        | 5144          |
| 7  | 11                      | 19                      | 18                      | 48           | 126.7          | 43.0                        | 5448          |
| 8  | 15                      | 24                      | 17                      | 56           | 147.8          | 41.7                        | 6163          |
| 9  | 14                      | 21                      | 20                      | 55           | 145.2          | 38.6                        | 5605          |
| 10                                       | 12                      | 14                      | 15                      | 41           | 108.2          | 45.1                        | 4880          |
| 11                                       | 9                       | 11                      | 15                      | 35           | 92.4           | 49.1                        | 4537          |
| 12                                       | 8                       | 14                      | 12                      | 34           | 89.8           | 48.7                        | 4373          |
| 13                                       | 9                       | 14                      | 10                      | 33           | 87.1           | 50.2                        | 4372          |
| 14                                       | 9                       | 14                      | 11                      | 34           | 89.8           | 52.9                        | 4750          |
| 15                                       | 10                      | 15                      | 13                      | 38           | 100.3          | 47.1                        | 4724          |
| 16                                       | 15                      | 20                      | 17                      | 52           | 137.3          | 43.1                        | 5918          |
| 17                                       | 14                      | 21                      | 23                      | 58           | 153.1          | 33.2                        | 5083          |
| 18                                       | 12                      | 20                      | 15                      | 47           | 124.1          | 40.2                        | 4989          |
| 19                                       | 13                      | 14                      | 15                      | 42           | 110.9          | 39.8                        | 4414          |
| 20                                       | 16                      | 18                      | 19                      | 53           | 139.9          | 40.8                        | 5708          |
| 21                                       | 15                      | 20                      | 19                      | 54           | 142.6          | 43.2                        | 6160          |
| 22                                       | 15                      | 19                      | 18                      | 52           | 137.3          | 40.9                        | 5616          |



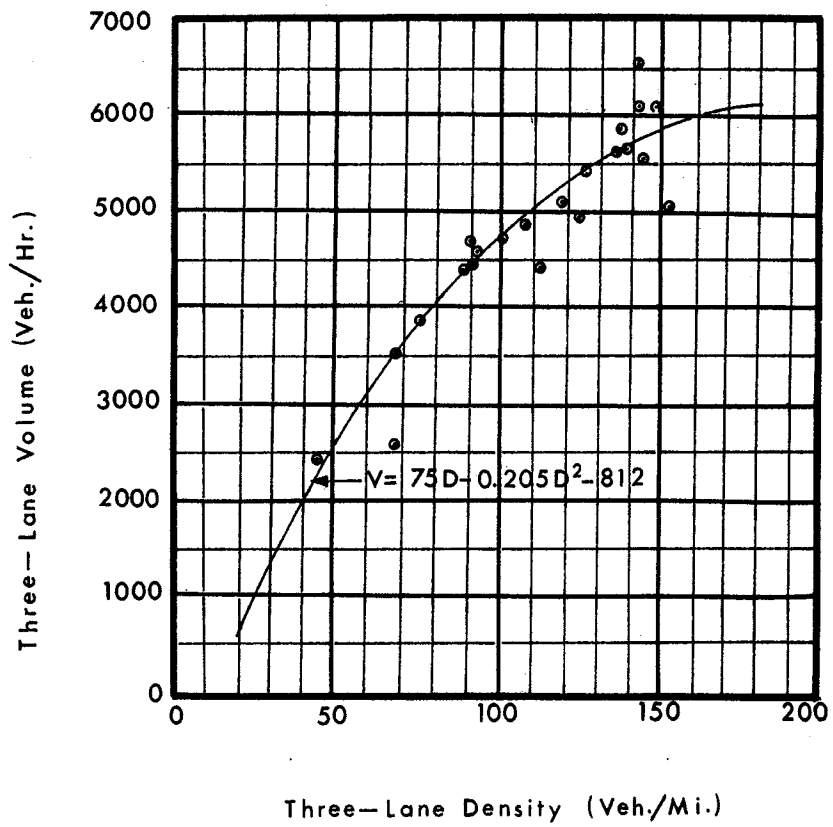

Figure 8. Volume-Density Relationship Obtained from Continuous Strip Aerial Photography

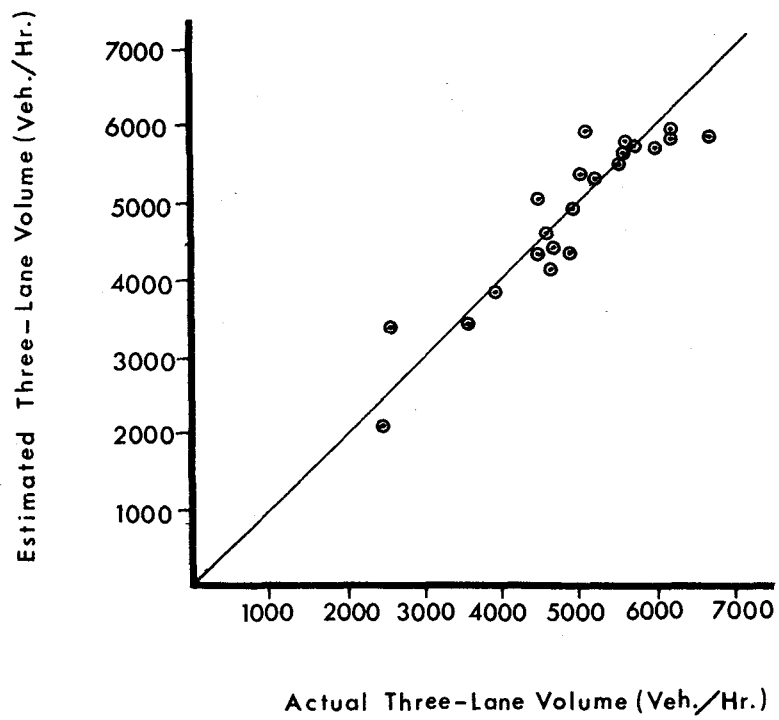

Figure 9. Estimated Volume Versus Actual Volumes Obtained in the Continuous Strip Aerial Photography Study

variation in actual volume.

If the parabolic expression is differentiated with respect to density,

$$\frac{dV}{dD} = 75 - 0.41D$$

and  $\frac{dV}{dD} = 0$ , then

$$D = \frac{75}{0.41} = 183$$

which is the density associated with the maximum volume. The maximum volume would then be

$$\begin{aligned} V &= 75(183) - 0.205(183)^2 - 812 \\ &= 13,725 - 6865 - 812 \\ &= 6048 \text{ vehicles per hour for three lanes.} \end{aligned}$$

## IV

### DENSITY TRAP STUDY METHOD

#### GENERAL CONCEPTS

In view of the expense of aerial photography methods of studying freeway traffic flow characteristics and because only a few instantaneous states of density were available from such studies, it was necessary that another study procedure be developed which would provide more, and preferably continuous, density information. Economy and mobility were important factors in the development of this procedure. It is emphasized that the study method which was developed was not basically a method to be developed for automatic density sensing; some desirable features of automatic density sensing are discussed in Part II. This procedure involved a means of obtaining a continuous record from which actual densities, or more correctly, vehicular concentrations within a section of the freeway were derived after a data reduction of the record.

The density trap involves a selected length or section of roadway. The upstream end of the lanes of one-direction traffic constitutes the beginning of the trap or the "in" point. The downstream end of the section is the end or "out" point. Vehicles are counted in and out of the section or trap. The simplest case is that which involves no entrance or exit points within the trap. The number of vehicles,  $k$ , in the trap at

any time,  $t$ , can be expressed

$$k = k_0 + \sum_{T=t_0}^t I(T) - \sum_{T=t_0}^t O(T)$$

where  $k_0$  is the number of vehicles in the trap at some beginning time,  $t_0$ ,  $I(T)$  is the number of vehicles passing in as a function of time and  $O(T)$  is the number of vehicles passing out as a function of time.

Several practical problems exist when attempts are made to put this principle into actual use. First, the vehicles must be counted very accurately because any error made in counting will be thereafter reflected in the concentration,  $k$ . Second, since the number of vehicles passing in and out have the same time base, there should be no error in synchronization of the beginning time or lapsed time after beginning. Third, the number of vehicles,  $k_0$  in the trap at a beginning time,  $t_0$ , is not readily determinable. Finally, the record of such values as  $k$ ,  $I(T)$ , and  $O(T)$  is continuously changing in time and requires some dependable recording scheme.

#### METHOD DESCRIPTION

It was decided, as a matter of expediency, that the vehicles would be counted manually. Adequate numbers of personnel were available who had experience in counting traffic and it was felt that automatic vehicle counters were not economically justified. The installation of the counters would have also been time consuming and would not have had the mobility

of human observers. It was realized that a method of checking would have to be developed regardless of whether automatic or manual counters were used.

In order to obtain a common time base and properly synchronize all in and out counts, it was decided that each observer, or traffic counter, would operate an electrical switch which was wired to an electrical counter mounted on a centrally located counter board. All counters for both the "in" and "out" points were mounted on the same counter board, thus could be observed simultaneously at any instant in time. Figure 10 shows a wiring scheme for the density trap method.

In order to accurately ascertain the number of vehicles,  $k_0$ , in the trap at some beginning time,  $t_0$ , a span of pace cars were required to maneuver such that they were abreast of each other when traveling through

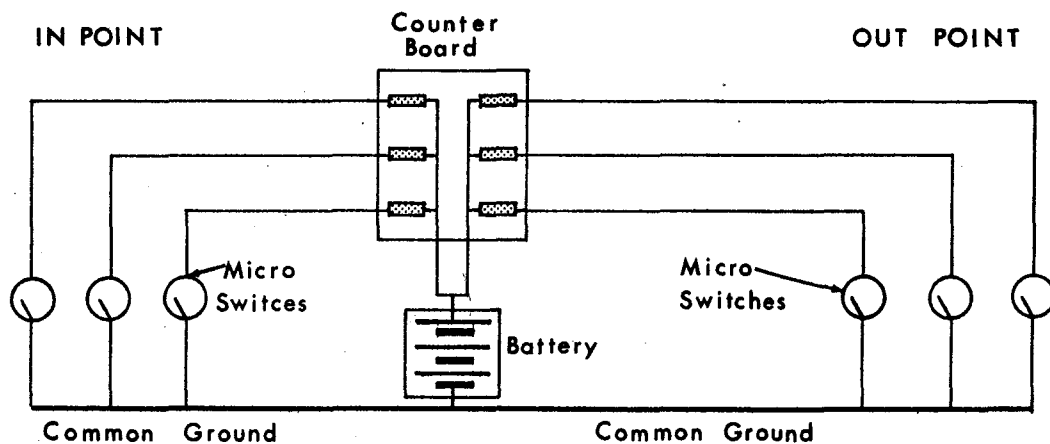

Figure 10. Wiring Scheme for Density Trap Apparatus

the trap thus preventing any vehicles from passing them or their passing any vehicles.

The pace cars were the first cars counted by every observer, thus, when the out points began counting, the difference between the total in and the total out was the actual concentration of vehicles within the trap.

A check on the accuracy of the counting was provided by having the pace cars pass through the section a second time to end the count. The pace cars passed through the section abreast and were the last vehicles counted by every observer. The final totals of the vehicles in and the vehicles out were identical if no mistakes had been made in counting.

The recording of the data was accomplished by photographing the counter board with a 16 mm. moving picture camera at a rate of 10 frames per second. This system provided a continuous record of the density trap studies, each of which lasted from about 6 to 18 minutes. The reaction time of the observers was found to vary about 0.2 second. Several observers were required to actuate their counting switches for the same vehicles passing a given point in order to determine this variation. This variation in counting could have been overcome by using automatic vehicle counters; however, for the purposes of this study of vehicular densities, manual counting was considered sufficiently accurate. The camera speed of 10 frames per second was deemed sufficiently fast consistent with the variation in manual counting accuracy.

The counters were flush-mounted on a small plywood board which comprised the face of a folding leg frame. An electric clock from an automobile was mounted on the face of the panel and was operated by a 12 volt dry cell battery. The clock provided a record of the time of day and, by observing the second hand, an accurate check was made of the number of frames per second taken by the moving picture camera. The camera was equipped with a 1200 foot film magazine and an electric drive. The power for the camera drive motor was provided by a portable, gasoline-powered generator. Figure 11 shows the camera in position for filming the counter board during a study at the Gulf Freeway in Houston.

Radio communication between the pace car drivers, the filming station

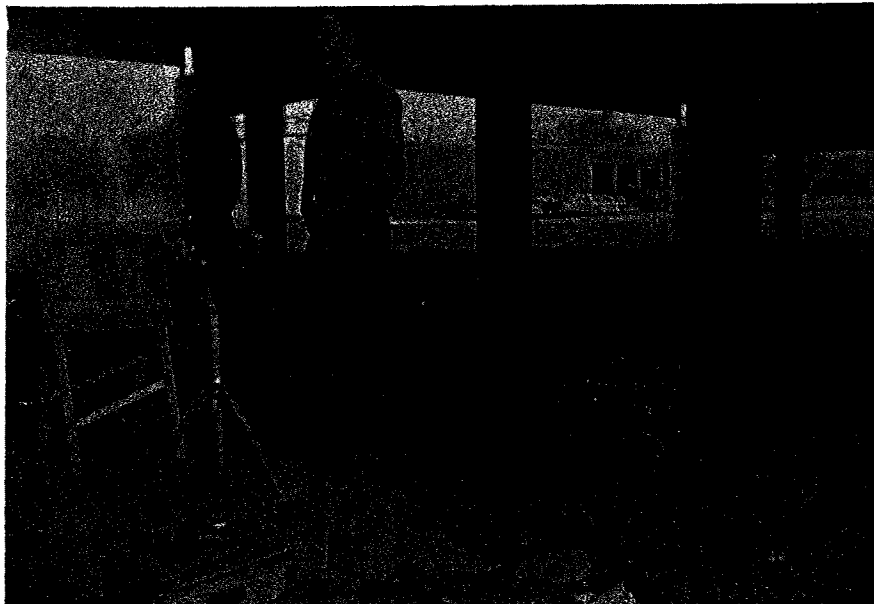

Figure 11. Filming Station for Density Trap Study



and the counter stations was provided. Ideally, there would be a total of four transceivers for such a study; one in a pace car, one at each counting station, and one at the filming station. Each transmitter should have a range of several miles in order to insure communication with the pace car which might be required to travel considerable distances from the trap section. Field telephones could be utilized between the ground stations and thus a minimum of two radios would suffice. Figure 12 shows a group of three observers and a supervisor standing in position just off the shoulder of the freeway. In some instances, it was necessary to make counts at a location on a bridge where the sidewalk was too narrow to safely accommodate the observers. In such cases, use was made of a hydraulic lift platform as shown in Figure 13. The Texas Highway Department and some City Traffic Departments utilize such trucks in the maintenance of signs and traffic signals.

The moving picture films, after being developed, were analyzed on a 16 mm. time-motion projector. These projectors are equipped with frame counters and can be advanced such that the film can be studied frame by frame. In the data reduction of the film, it was necessary to record each counter actuation and the associated frame number. Clock times were recorded every 1000 frames, or approximately every 100 seconds, in order to confirm the filming speed. The counters rotated half way toward the next digit upon contact closure and completed the rotation when the con-



Figure 12. Manual Count Station at Edge of Freeway.

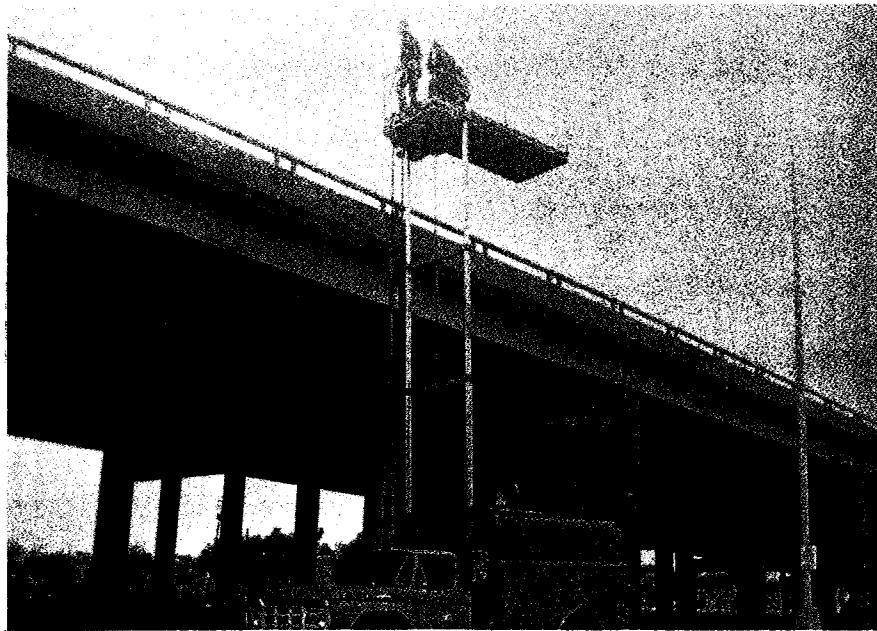

Figure 13. Manual Count Station Adjacent to Bridge

tact was broken. Attention was given to recording the precise frame number of the initial contact closure.

An added feature of the density trap method was incorporated during the studies made in early 1964 in order to obtain the travel times of several vehicles through the trap section. Two additional counters were used for this purpose and were also mounted on the counter board. Additional circuits with switches were provided similar to the counting circuits for each of the two additional counters. The observers using these counters were stationed at each end of the trap section near the volume count observers and were provided with communication with one another. Either field telephones or portable radios could be used for this purpose. The observer stationed at the in point selected a "floating" vehicle and actuated his switch when the vehicle entered the trap section. He then described the vehicle to the other observer at the out point, who, in turn, actuated his counter when the described vehicle exited the trap. The filmed record of these two counters provided sufficient information to calculate the speeds of these vehicles through the trap.

It should be pointed out that the trip times through the trap were not necessary, but were obtained as a possible source of verification of speeds calculated from the volume and density information obtained in the study.

A total of six density trap study runs were made in Houston on

Wednesday morning, November 27, 1963. The study site was selected on the Gulf Freeway in the region of Station Number 100. The inbound lanes of the facility have no entrance or exit ramps for a distance of about 1800 feet at this particular location (see Figures 6 and 7). The out-count station was set up at Station 86 + 50 and the in-count stations were set up at three different points in order to vary the trap length. In-point stations at 92 + 30, 95 + 40, and 102 + 80 provided trap lengths of 580 feet, 890 feet and 1630 feet respectively. Personnel from the Texas Transportation Institute and the Texas Highway Department were utilized in making the Houston studies. Table 2 lists the run numbers and lengths of trap sections and also shows the difference in the final in and out counts obtained. Only runs 1, 4, and 5, which tallied exactly, were reduced frame by frame for complete analysis. The film reduction, frame by frame, required two persons about 42 hours of moving projector time and about 84 man-hours.

No serious congestion occurred during any of the six study runs. Information concerning volumes of traffic associated with high densities was desired.

A new study site for congested conditions was sought which would provide vantage points for observers from which they could make accurate counts without calling attention to themselves. The North Central Expressway in Dallas is a partly depressed facility, that is, it passes under many

TABLE 2

Summary of Density Trap Study Method Runs in Houston

| <u>Run No.</u> | <u>Time (A.M.)</u> | <u>Run Duration</u> | <u>Trap Length</u> | <u>Total Vehicles In</u> | <u>Total Vehicles Out</u> | <u>Count Error</u> |
|----------------|--------------------|---------------------|--------------------|--------------------------|---------------------------|--------------------|
| 1              | 7:40               | 15 min              | 580'               | 1268                     | 1268                      | 0                  |
| 2              | 8:30               | 12 min              | 890'               | 749                      | 746                       | 3                  |
| 3              | 9:15               | 12 min              | 1630'              | 476                      | 477                       | 1                  |
| 4              | 10:45              | 12 min              | 1630'              | 499                      | 499                       | 0                  |
| 5              | 11:10              | 11 min              | 890'               | 466                      | 466                       | 0                  |
| 6              | 11:40              | 11 min              | 580'               | 419                      | 421                       | 2                  |

of the major streets. The embankments in the regions of overpassing major streets or the overpassing structures themselves provide positions from which observers can accurately count traffic from less obvious positions. At the Haskell Street overpass, the North Central Expressway provides a section about 1200 feet in length with no entrance or exit ramps. This section of Expressway was observed to congest rather heavily each day on the outbound lanes during the P.M. peak. On Friday afternoon, February 7, 1964, personnel from the Texas Transportation Institute and Arlington State College made a study at the Haskell Street location on the North Central Expressway. The study involved two runs, hereafter referred to as runs 7 and 8. Run 8 involved a difference of 9

vehicles in the in and out count and was not analyzed frame by frame.

Run 7 was made at about 5:00 p.m. and had a duration of six minutes.

The trap length was 900 feet and the total vehicles counted was 459, at both the in and out stations.

ANALYSIS OF DENSITY DATA

DENSITY DATA CONCEPT

Volume, when reduced to its most elemental form based on time gaps between successive vehicles, is quite widely variable. Of course, when longer periods of time are used to count more than two vehicles, the variability is reduced. In the density trap study method, the volume in and the volume out of a particular section might be represented as shown in Figure 14. Although the shortest-term volume rates in and out may be quite variable, the density of vehicles within the section will be less variable if there is an average of over two vehicles in the trap. The volume out is not independent of the volume in. If an average travel time through the trap were  $\Delta t$ , there would be similarity between the two volumes if the origin of the volume were shifted an amount equal to  $\Delta t$ .

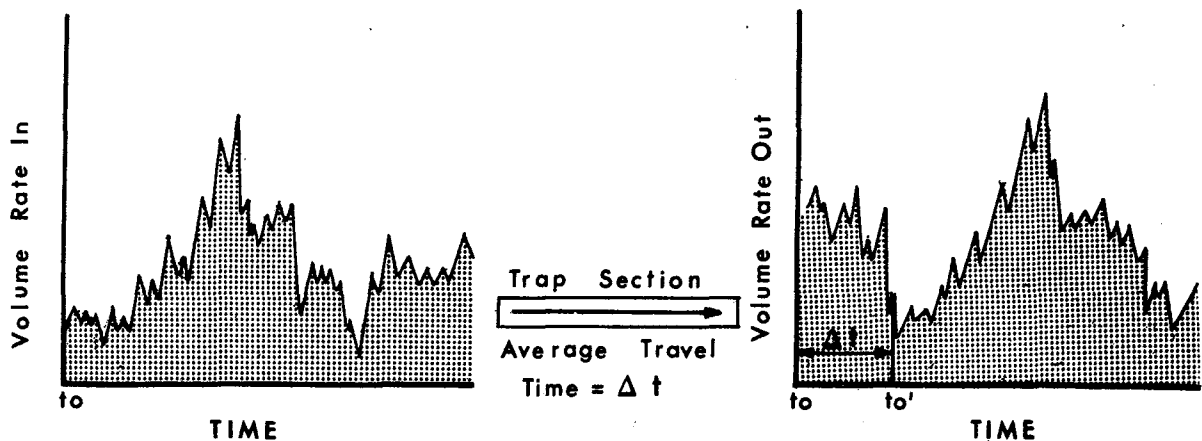

Figure 14. Volume Rates In and Out of a Density Trap

As the trap length increases, this similarity between volumes tends to diminish. The longer the trap length, the less variable the density will be. This is comparable to a longer counting period for volumes entering (and leaving).

#### DENSITY-VOLUME RELATIONSHIP

The density trap study method provided considerable data suitable for establishing the relationship between density and volume. The approach in this analysis involved the assumption that a short-term rate of flow-in immediately preceding any specific concentration should be compared to that concentration. Furthermore, the short-term rate of flow-out immediately succeeding any particular concentration was compared to that concentration. The basis for this concept is illustrated in Figure 14. The time involved in the rates of flow were based on the approximate average travel time through the trap. The average travel times through the trap were either measured, as described earlier, or obtained from the time required for the pace cards to traverse the trap at the beginning and end of any run. Since a rate of flow was being computed which involved dividing the number of vehicles observed during the time period by that time period, the precise time interval to be used was not of absolute importance as long as the time interval was generally about the average travel time for the trap. The time intervals used for the various runs analyzed are shown in Table 3.



TABLE 3

Density Trap Study Method Travel Time  
And Space Mean Speed Tabulation

| <u>Run No.</u> | <u>Average Travel Time</u><br>Hrs. | <u>Average Speed</u><br>(Mi./Hr.) |
|----------------|------------------------------------|-----------------------------------|
| 1              | 0.00300                            | 36.6                              |
| 4              | 0.00680                            | 45.4                              |
| 5              | 0.00357                            | 47.2                              |
| 7              | 0.01070                            | 15.9                              |

A computer program was written to determine the rates of flow in and out for each concentration obtained in runs 1, 4, 5, and 7 and the rates of flow were extended to volumes, in vehicles per hour, and the concentrations were expanded to density, in vehicles per mile. A curvilinear regression involving a second degree parabola resulted in the equation

$$V = 65.5D - 0.179D^2 - 80$$

Only every twentieth value of density and the corresponding value of volume is shown in Figure 15. The large number of obtained points renders plotting every point impractical.

When this expression is solved for the maximum volume, by differentiating and setting  $\frac{dv}{dD} = 0$ , the maximum volume is 5930 vehicles per hour for three lanes and the optimum density associated with this maximum volume is 183 vehicles per mile for three lanes.

The differential of this equation,  $\frac{dv}{dD} = 65.5 - 0.358D$ , represents the

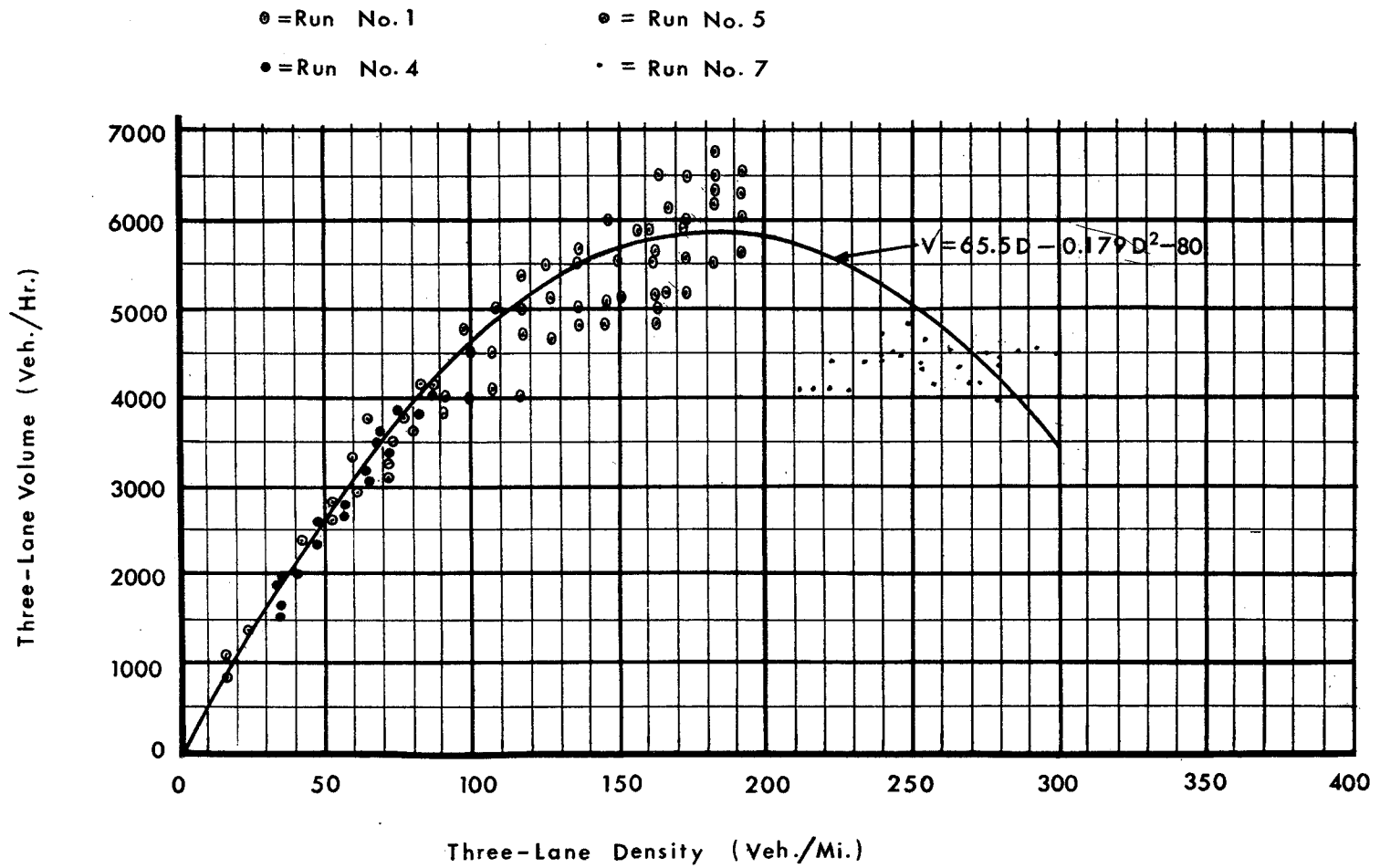

Figure 15. Volume-Density Relationship Obtained From Density Trap Studies

slope of the volume-density curve at any point and when density is zero, the slope is 65.5. The slope at zero density is what might be termed the "free flowing" speed of the section of freeway since the slope is volume, in miles per hour divided by density, in vehicles per mile which is equal to the space mean speed in miles per hour. To be completely correct, the curve should pass through the origin; however, this curve comes considerably closer to the origin than the one developed in the continuous strip aerial photography study.

The true shape of the volume-density curve past the maximum volume point is difficult to ascertain. The volumes associated with extremely congested traffic conditions are known to be quite small and the density reaches its maximum value when the stream of vehicles has been halted in a "bumper to bumper" stoppage. For the purposes of this study, it is not necessary to determine this branch of the curve; the maximum volume and its associated density is the limit of importance in using density as an element of control. It is believed that the density trap method, however, might be a useful study procedure for determining the congested, or right, branch of this curve.

#### THE VARIABILITY OF CONCENTRATION

Although density is, by current usage, defined as the number of vehicles in a one-mile length of roadway, concentration is taken to mean the number of vehicles in a length of roadway less than a mile long. The

two important factors affecting the variability of concentration are the length of section involved and the volume of traffic.

A simulation of freeway traffic with an IBM 709 digital computer (3) indicated that distributions of concentrations could be approximated rather closely by the Poisson distribution, particularly for light to medium volumes of traffic. This simulation indicated that the mean concentration was directly proportional to the length of section involved for any given volume. The simulation furthermore indicated that the variability of concentration was inversely proportional to the length of section involved for any given volume. Specifically, the standard deviation of concentrations was related to the length of section by the following relationship:

$$\sigma_1 \sqrt{\frac{L_1}{L_2}} = \sigma_2, \text{ where } \sigma_1 \text{ is the standard deviation of the concentrations}$$

observed in a length of section  $L_1$ , and  $\sigma_2$  is the standard deviation of the concentrations observed in a length of section  $L_2$ . The lengths of sections investigated ranged from 500 feet to 2000 feet.

The standard deviations were observed in the simulation program to be a function of volume, however, for a section length of 1000 feet,  $\sigma$  ranged between 3 and 4 vehicles for all volumes. The actual validity of these simulated variations was established rather well by the field studies.

The frequency distributions of concentrations obtained from the density trap field studies were calculated on a time basis. The frequency, in other words, refers to that portion of the time that a particular concen-

tration was observed. Figure 16 shows the frequency distributions for runs 1, 4, 5, and 7, and the Poisson distribution with the same mean value is superimposed on each plot. Runs 4 and 5, as previously stated, involved moderate to light volumes of traffic and it is seen that the concentration distributions are quite similar to Poisson distributions. The standard deviations of these two runs are approximately equal to the square root of the mean, which would be the case for a Poisson distribution. Run 1 involved high volume flow, or generally optimum volume of flow. The distribution of density for this run is observed to be significantly less variable than the corresponding Poisson distribution. Run 7 involved congested flow conditions with volumes less than optimum. The standard deviation obtained in this run was considerably less than would have been obtained with a Poisson distribution.

It should be pointed out that there was no control of volume in these field studies and only the lengths of traps were varied. The durations of the runs were comparatively short, however, and it is unlikely that a general change in the volume occurred during any specific run. The lengths of the traps had an obvious effect on the mean value of concentration for any similar volume conditions. For example, the mean concentration value, considering moderate to light volumes of traffic, of a trap length of 1630 feet in run 4 was 15.67 vehicles as compared to a mean of 8.72 in a trap length of 890 feet in run 5. The standard deviation of the

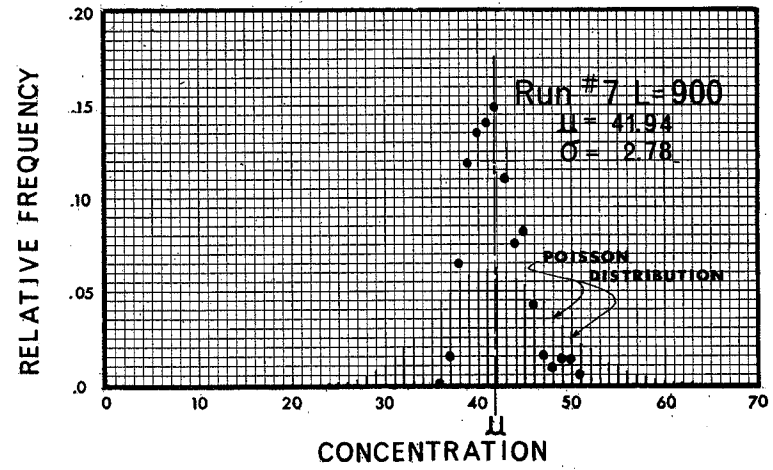
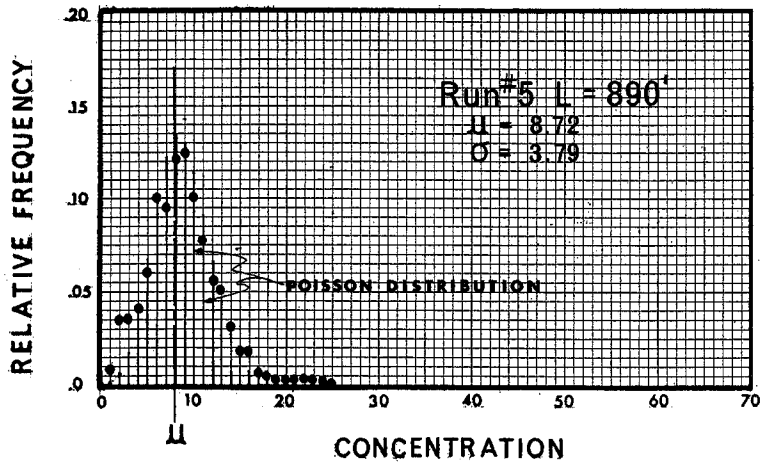
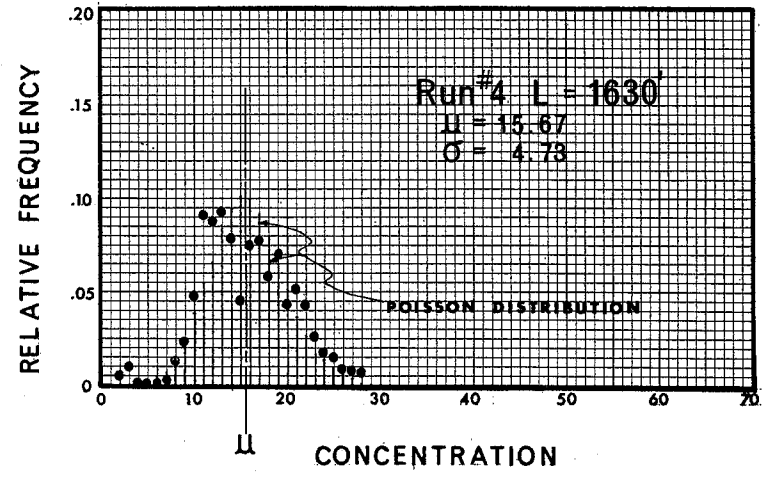
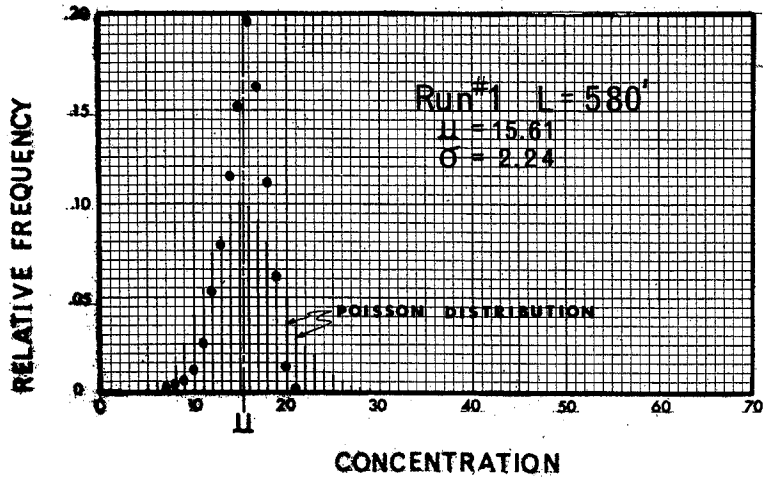

Figure 16. Concentration Distributions Obtained From Density Trap Studies

concentrations in run 4 was approximately equal to the square root of the ratio of the trap length used in run 4 to the trap length used in run 5 times the standard deviation of concentrations in run 5, or

$$\sigma_4 = \sqrt{\frac{L_4}{L_5}} \sigma_5 .$$

This would appear to be a fairly reliable relationship between the lengths of sections involved and the variability of concentrations for light and medium volumes. For the greatest volumes as well as for the congested flow conditions, the variability of concentration was observed to be considerably less than for the light to moderate volumes. It might be pointed out, however, that for runs 1 and 7 the relationship

$$\sigma_7 = \sqrt{\frac{L_7}{L_1}} \sigma_1$$

did happen to be very nearly correct.

The standard deviations obtained in these four field studies were all calculated for an arbitrary trap length of 1000 feet by using the relationship

$$\sigma_{1000} = \sqrt{\frac{1000}{L_m}} \sigma_m$$

Table 4 lists these values along with the approximate volumes. The values in these studies indicate that the standard deviation of concentrations observed in a 1000 foot section of three lanes of freeway will be about three for high volume flow and also for congested lower volumes and, for light to moderate traffic flow conditions, will be about four. Stated another way, it

can be said that the standard deviation of concentrations observed in a 1000 foot section was found to be about four for lower concentrations and three or less for medium to high concentrations.

TABLE 4

Standard Deviations Obtained in Density Trap Studies

| <u>Run Number</u> | <u><math>\sigma</math> m</u> | <u><math>\sigma</math> 1000</u> | <u>Approximate Volume</u> |
|-------------------|------------------------------|---------------------------------|---------------------------|
| 1                 | 2.24                         | 2.94                            | 5050                      |
| 4                 | 4.73                         | 3.71                            | 2550                      |
| 5                 | 3.79                         | 3.94                            | 2650                      |
| 7                 | 2.78                         | 2.88                            | 4300                      |



## VI

### SELECTION OF LENGTHS AND LOCATIONS FOR DENSITY SENSING

#### LOCATIONS OF CRITICAL OR BOTTLENECK SECTIONS

Aerial photogrammetry studies of traffic flow characteristics have been analyzed for density contours by May, Athol, Parker, and Rudden (5). In such an analysis, the concentrations of vehicles along the roadway are obtained for successive short time intervals of about five minutes. A contour is obtained by plotting the densities on a chart with the station numbering (100 foot stations) as an abscissa and time of day as ordinate. Studies made during peak traffic flow periods will show the position, or station numbering, of high density locations and the time of day the high densities exist. The duration of high density, or congested conditions, can be determined by noting the vertical height (time) of any particular density contour at a particular location along the freeway. If studies made on several different days have similar locations of high density conditions, it is reasonably certain that the particular locations are critical or bottleneck sections.

The aerial photogrammetry studies made on the Gulf Freeway in the fall of 1962 were analyzed for the purpose of plotting density contours. Drew (6) has shown that the morning peak flow toward the city of Houston results in several locations of high density flow. Figure 17 shows the results of the three-lane density contour for the Gulf Freeway from 6:45 to

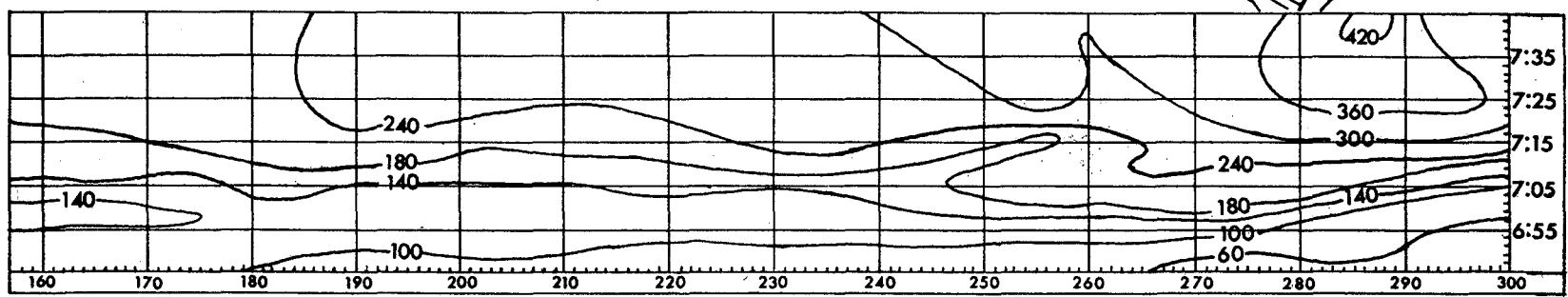
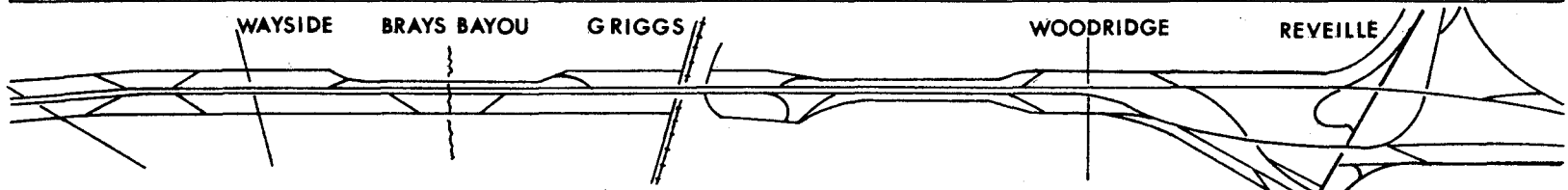
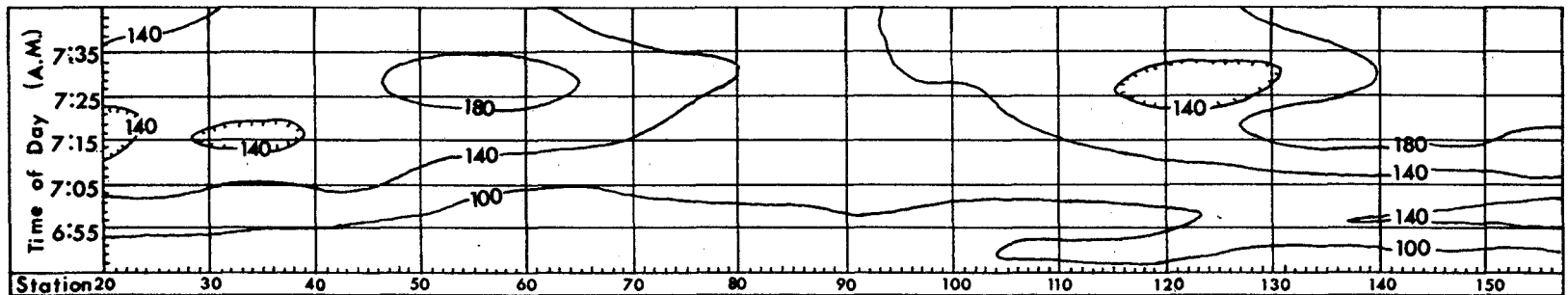
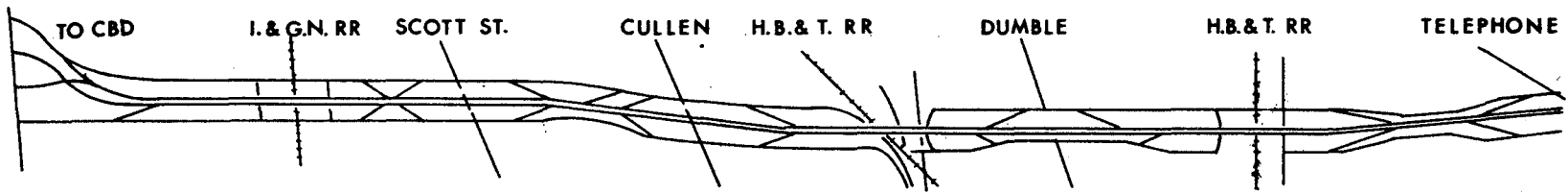

Figure 17. Density Contours (Three-Lane Total)

7:45 a.m. A line sketch of the freeway, frontage roads, entrance ramps, and exit ramps is shown above the contours.

It can be seen that in the region of Station 285 + 00 extremely high densities did occur. A three-lane density of over 420 vehicles per mile corresponds to almost a complete stoppage of vehicles, or, at best, a stop-and-go or crawling-speed condition. The merging of two state highways with the Gulf Freeway at this location presents a serious problem on the facility. Subsequent studies made on the Gulf Freeway indicate that the critical sections shown on this density contour generally tend to appear at the same locations more or less regularly.

This study procedure appears to provide a useful basis for the selection of density sensing locations. The contours also seem to indicate that lengths of 1000 feet or less might suffice for density sensing trap lengths.

#### CONSIDERATIONS OF DENSITY SENSING SECTION LENGTHS

The volume-density relationship obtained from field studies of a section of the Gulf Freeway indicated that the density associated with the maximum flow rate was about 180 vehicles per mile for three lanes. The concentration in a section 1000 feet long corresponding to this optimum density would be about 34 vehicles. The variability of concentration in a 1000 foot section indicated that the standard deviation of concentration would be about three vehicles for moderately heavy or heavy volumes and that the distribution of concentrations would be approximately normal. A

standard deviation which is only 9 percent of the mean concentration indicates the high degree of reliability which is inherent in sensing concentration (or density), and, as it has been pointed out, this sensing can be continuous thus affording instantaneous indications of the traffic flow condition.

It may not be economically feasible or even necessary to sense density continuously along a freeway facility. A density contour analysis would seem to provide a basis for the selection of sections to be sensed. There is an indication that the standard deviation of the concentration, for any specific volume of traffic, is related to the length of section being sensed by the equation

$$\sigma_1 = \sqrt{\frac{L_1}{L_2}} \sigma_2 .$$

As the length of a sensing section increases, the concentration of vehicles increases proportionally. The standard deviation increases proportional to the square root of the section length, thus, the ratio of the standard deviation to the mean decreases as the length of section increases. Figure 18 shows this relationship. It would appear that little increase in confidence would result from sections longer than 1500 feet and that acceptable sensing reliability may be possible with sections as short as 500 feet.

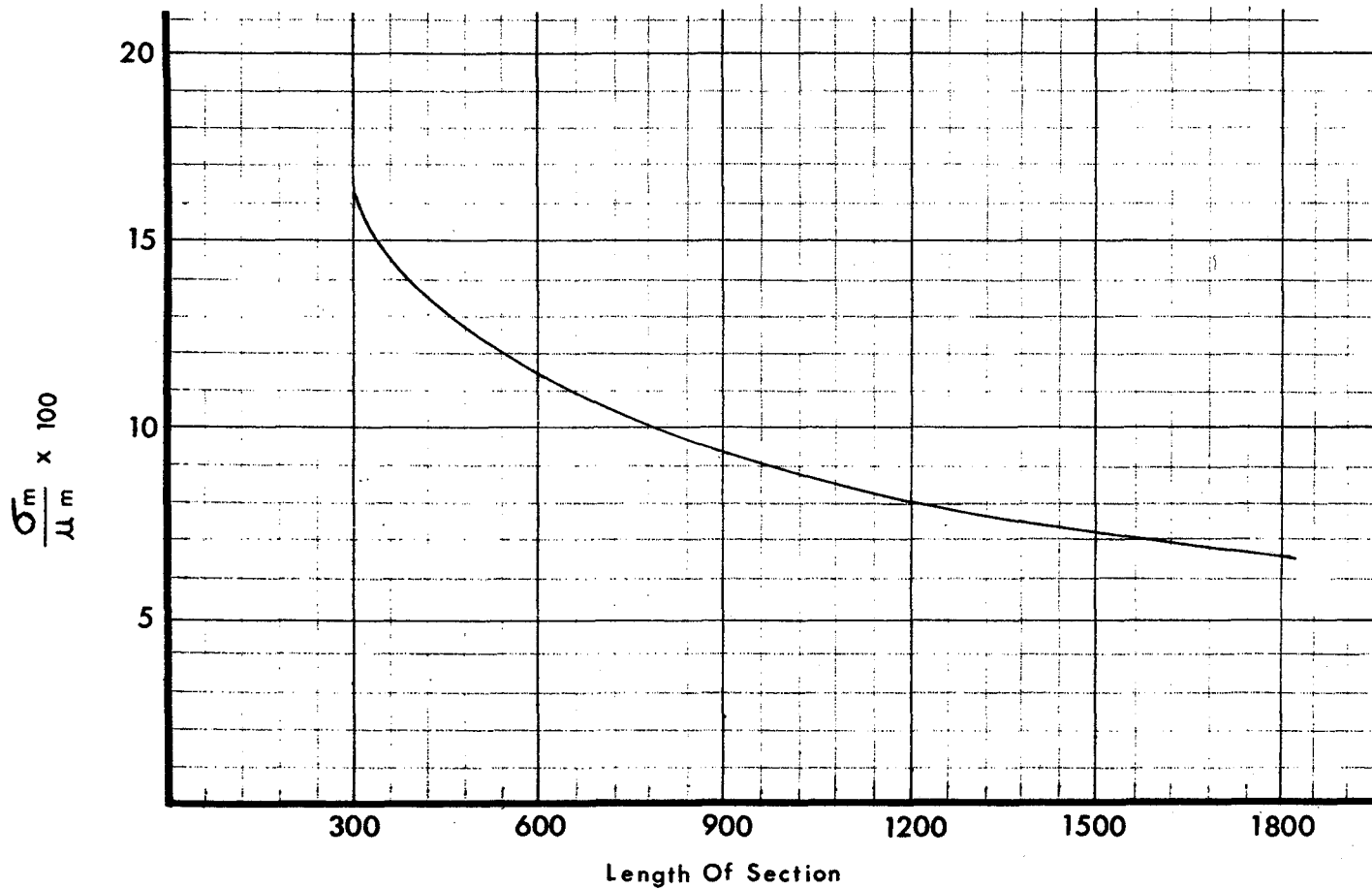

Figure 18. Relationship Between the Standard Deviation Percent of the Mean Concentration and the Length of Sensing Section at High Volumes

CONCLUSIONS AND RECOMMENDATIONS

This study of vehicular density has singled out the one element of the traffic stream which, because of the difficulty of measuring it directly, has been largely relegated to be the dependent variable in the expression  $q = k v$ . By a focused attention upon this element, this study offers these conclusions, subject to the recommendations which follow.

CONCLUSIONS

1. Density, or concentration, is an independent element of the traffic stream which is subject to direct measurement, feasible to sense directly and is most directly related to the congestion of traffic. The  $q$ - $k$ - $v$  surface, as shown in Figure 1, is a useful concept in considering the relationship between speed, volume, and density.
2. Reasonably close agreement was found between the maximum or optimum density and theoretical optimum densities. It is possible, with field studies, to establish the optimum density, associated with a maximum volume, for particular sections of a freeway, and these optimum densities may not be the same for all sections along a freeway.
3. Frequency distributions of densities were found to be closely approximated by the Poisson distribution, or a random spacing of the vehicles, for light and medium volume conditions, or uncongested conditions; the distribution of densities was found to be considerably less variable, however,

for heavy volume or congested flow conditions. These relationships agree with several theoretical considerations of traffic flow.

4. The mean concentration of vehicles within a section was a function of volume which was approximated rather well by a parabolic relationship for the light traffic volumes up through the maximum volumes of flow.

5. The mean concentration was also proportional to the length of the section considered.

6. The variance of the concentrations was approximately proportional to the length of the section involved. Thus, the standard deviation was approximately proportional to the square root of the section length. For any particular volume, an increase in section length will result in a standard deviation of concentration which is a smaller percentage of the mean concentration.

7. Density sensing systems can offer the unique advantage of having continuous and instantaneous values for use in the control of freeway traffic systems and will not depend upon some time interval for counting and averaging before a new output is available for control purposes.

8. It is possible to develop a density sensing system utilizing high frequency, transmission-line type sensors which make use of voltage shifts caused by vehicles adjacent to the sensors.

9. Aerial photography methods of studying traffic characteristics can be utilized to determine volume-density relationships; such methods are use-

ful in obtaining the density contours for a facility. The density contours can be used to identify the regular bottleneck sections which recur daily.

10. The density trap method of study offers advantages in studying the continuously variable nature of density and the relationship between density and speed and volume.

### RECOMMENDATIONS

An actual density sensing system needs to be developed and produced for evaluation. Such a system should have a continuous output proportional to the sum of the vehicles in the section at any instant and should not be based on the result of a subtraction process or data processing which subtracts a downstream count from an upstream count. A proper system would not involve a cumulative, or increasing error if a particular sensor in the system failed, but would continue to give an output in error only by the amount attributed to the faulty sensor.

A density sensing system which has been properly evaluated should be installed at a section or sections on a freeway which have been previously selected as critical locations by the density contour method of analysis. The density sensing system should then be studied as an operational control system. The critical values of density predetermined from traffic studies should be corrected for any observed inaccuracies. It will be necessary to consider the entire freeway system in establishing critical densities for control in order to insure a balanced or optimum operation of the system.



Studies should be made to determine what minimum portion of the total length of controlled freeway should be sensed for density in order to obtain the required degree of reliability for operational control. A combination of volume sensing and density sensing could be considered in the determination of the minimum proportion of freeway to be sensed for density. Although density sensing can be useful in freeway operation control, a lengthy freeway section probably should have volume sensing used in combination with density sensing over certain lengths of the total section. A very long section sensed for only density would not present information concerning the bunching of vehicles within the sensed section; volume information would be useful in combination with density information in this respect.

Little has been done to relate the nature of one-lane traffic flow characteristics to multiple-lane flow characteristics. It is possible to sense density by lane as well as by total of all lanes. Relationships between individual lane densities and total densities should be established by further studies.

The density trap method of studying traffic could be improved. Automatic vehicle counters could perhaps be utilized to replace the manual counters. The entire system could be operated wireless, or by radio, rather than by multi-wire cable and the voice communication could then be incorporated into the radio counters. In special locations where closed circuit television surveillance systems are in operation, it is possible to make density trap

studies by viewing the monitors. This study method offers direct information concerning concentration, volume rate, and speed and is a useful study procedure for determining the relationships between these basic elements of a traffic stream. The process of data reduction from the motion picture film is rather tedious. Improvements could be made in this process, particularly if the records were made on punched tape rather than motion picture film. A machine reduction of the information would then be possible.

The congested portion of the volume-density relationship should be investigated further. The density trap method should prove to be a useful procedure for such studies. The right branch, or congested portion, of the volume-density relationship should be less influenced by the geometrical features of the roadway or the geographic location of the way drivers space themselves at slow speeds in congested conditions.

APPENDIX

## DEFINITION OF TERMS

Bottleneck: A section which has a smaller capacity for accommodating vehicles than adjacent sections upstream or downstream.

Concentration: The accumulation, or number, of vehicles within a section of roadway less than one mile in length.

Congested Operation: Operation at densities, or concentrations, greater than the critical density.

Critical Density: The density at which the maximum flow rate, or volume, occurs.

Density: The number of vehicles with a one mile length of roadway.

Density Trap: A section of roadway for which the input and output volumes are measured synchronously.

Light Volume Operation: The uncongested traffic operation involving volumes less than maximum and densities less than critical.

Rate of Flow: The number of vehicles passing a given point on a roadway in a period of time less than one hour.

Section Length: A length of roadway under consideration for vehicular concentration.

Sensing: The automatic detection of some aspect of traffic flow.

Space Mean Speed: The mean, or average, speed of the vehicles within a given space of roadway.

Time Mean Speed: The mean, or average, speed of the vehicles passing a given point during some period of time.

Volume: The number of vehicles passing a given point on a roadway in a one-hour period.

## REFERENCES

1. "Spot Speed Survey Devices," by the Institute of Traffic Engineers Technical Committee 7-G, "Traffic Engineering, Vol. 32, No. 8, May, 1962, pp. 45-53.
2. Keese, C. J., Pinnell, C., and McCasland, W. R., "A Study of Freeway Traffic Operation," Highway Research Board Bulletin 235, Washington, D. C., 1959.
3. Haynes, John J., The Development of the Use of Vehicular Density as a Control Element for Freeway Operation, A Dissertation Submitted for Publication at Texas A&M University, College Station, Texas, August, 1964.
4. McCasland, William R., "Comparison of Two Techniques of Aerial Photography for Applications in Freeway Traffic Operations Studies," Paper presented at the 43rd Annual Meeting of the Highway Research Board, Washington, D. C., January, 1964.
5. May, A. D., Athol, P., Parker, W., and Rudden, J. B., "Development and Evaluation of Congress Street Expressway Pilot Detection System," Highway Research Board, Record No. 21, Washington, D. C., 1963, p. 48.
6. Drew, Don R., A Study of Freeway Traffic Congestion, A Dissertation Submitted for Publication at Texas A&M University, College Station, Texas, May, 1964.

## PUBLICATIONS

### Project 2-8-61-24 Freeway Surveillance and Control

1. Research Report 24-1, "Theoretical Approaches to the Study and Control of Freeway Congestion" by Donald R. Drew.
2. Research Report 24-2, "Optimum Distribution of Traffic Over a Capacitated Street Network" by Charles Pinnell.
3. Research Report 24-3, "Freeway Level of Service as Influenced by Volume Capacity Characteristics" by Donald R. Drew and Charles J. Keese.
4. Research Report 24-4, "Deterministic Aspects of Freeway Operations and Control" by Donald R. Drew.
5. Research Report 24-5, "Stochastic Considerations in Freeway Operations and Control" by Donald R. Drew.
6. Research Report 24-6, "Some Considerations of Vehicular Density on Urban Freeways" by John J. Haynes.