

TEXAS
TRANSPORTATION
INSTITUTE

STATE DEPARTMENT
OF HIGHWAYS AND
PUBLIC TRANSPORTATION

COOPERATIVE
RESEARCH

**ANALYTICAL EVALUATION OF TEXAS
BRIDGE RAILS TO CONTAIN
BUSES AND TRUCKS**

in cooperation with the
Department of Transportation
Federal Highway Administration

**RESEARCH REPORT 230-2
STUDY 2-5-78-230
BRIDGE RAIL**

1. Report No. FWWATX78-230-2		2. Government Accession No.		3. Recipient's Catalog No.	
4. Title and Subtitle ANALYTICAL EVALUATION OF TEXAS BRIDGE RAILS TO CONTAIN BUSES AND TRUCKS				5. Report Date August 1978	
				6. Performing Organization Code	
7. Author(s) T. J. Hirsch				8. Performing Organization Report No. Research Report 230-2	
9. Performing Organization Name and Address Texas Transportation Institute Texas A&M University College Station, Texas 77843				10. Work Unit No. (TRAIS)	
				11. Contract or Grant No. Research Study 2-5-78-230	
12. Sponsoring Agency Name and Address Texas State Department of Highways and Public Transportation Transportation Planning Division P. O. Box 5051 Austin, Texas 78763				13. Type of Report and Period Covered Completion of Task Sept. 1, 1977 to Aug. 31, 1978	
				14. Sponsoring Agency Code	
15. Supplementary Notes Research performed in cooperation with DOT and FHWA Research Study Title: Bridge Rail to Contain Heavy Trucks and Buses					
16. Abstract <p>The recent multiple fatality anhydrous ammonia truck-bridge rail accident in Houston, Texas, and the school bus-bridge rail accident near Martinez, California, emphasizes the need for a bridge rail to contain heavy trucks and buses. Present bridge rails are only designed to restrain and redirect passenger cars up to 4500 lb (2041 kg) in weight traveling 60 mph (97 kph) and impacting the rail at a 25° angle. The current bridge rails must be at least 27 in. (69 cm) high and be able to resist a static load of 10,000 lb (4536 kg) without exceeding a specified allowable working stress based on an elastic analysis.</p> <p>Bridge rails designed in accordance with the present criteria have in general performed well in restraining passenger cars. Recent truck and Concrete Median Barrier (CMB) crash tests have indicated that some of our traffic rails designed by the present criteria have considerable reserve strength and are capable of redirecting heavy buses and trucks.</p> <p>The objective of the report is to present an analytical evaluation of the capabilities of six standard Texas bridge rails to contain automobiles, buses and trucks. This evaluation consisted of an analysis of the strength of the bridge rails to determine if they were strong enough to resist the impact forces. In addition, an analysis was made to determine if they are high enough to prevent high center-of-gravity buses and trucks from rolling over the rails.</p>					
17. Key Words Bridge Rails, Traffic Barriers, Heavy Vehicles, Highway Safety			18. Distribution Statement No Restrictions. This document is available to the public through the National Technical Information Service, Springfield, Virginia 22161		
19. Security Classif. (of this report) Unclassified		20. Security Classif. (of this page) Unclassified		21. No. of Pages 92	22. Price

ANALYTICAL EVALUATION OF TEXAS BRIDGE RAILS
TO CONTAIN BUSES AND TRUCKS

by

T. J. Hirsch
Research Engineer and Principal Investigator

Research Report 230-2

on

Research Study No. 2-5-78-230
Bridge Rail to Contain Heavy Trucks and Buses

Sponsored by

Texas State Department of Highways and Public Transportation

in cooperation with

The United States Department of Transportation
Federal Highway Administration

August 1978

Texas Transportation Institute
Texas A&M University
College Station, Texas

ABSTRACT

The recent multiple fatality anhydrous ammonia truck-bridge rail accident in Houston, Texas, and the school bus-bridge rail accident near Martinez, California, emphasize the need for a bridge rail to contain heavy trucks and buses. Present bridge rails are only designed to restrain and redirect passenger cars up to 4500 lb (2041 kg) in weight traveling 60 mph (97 kph) and impacting the rail at a 25° angle. The current bridge rails must be at least 27 in. (69 cm) high and be able to resist a static load of 10,000 lb (4536 kg) without exceeding a specified allowable working stress based on an elastic analysis.

Bridge rails designed in accordance with the present criteria have in general performed well in restraining passenger cars. Recent truck and Concrete Median Barrier (CMB) crash tests have indicated that some of our traffic rails designed by the present criteria have considerable reserve strength and are capable of redirecting heavy buses and trucks.

The objective of the report is to present an analytical evaluation of the capabilities of six standard Texas bridge rails to contain automobiles, buses and trucks. This evaluation consisted of an analysis of the strength of the bridge rails to determine if they were strong enough to resist the impact forces. In addition, an analysis was made to determine if they are high enough to prevent high center-of-gravity buses and trucks from rolling over the rails.

This analytical evaluation considered four sizes or types of vehicles as follows:

1. passenger cars up to 4500 lb (2041 kg) with a center of gravity about 20 to 24 in. (51 to 61 cm) above the road;

2. vans, recreational vehicles, and school buses up to 20,000 lb (9072 kg) with a center of gravity of from 50 to 60 in. (127 to 153 cm);
3. large intercity buses up to 40,000 lb (18,144 kg) with a center of gravity of from 52 to 64 in. (132 to 163 cm); and
4. large tractor-trailers up to 72,000 lb (32,659 kg) with a center of gravity from 45 to 78 in. (114 to 198 cm).

All impact forces were based on a 60 mph (97 kph) impact at 15 degrees for the heavy buses and trucks and 25 degrees for the passenger car.

One metal rail, the Texas T101 steel rail, three concrete parapet rails (Texas T201, T202, and T5), and two combination concrete parapet and metal rails (Texas T4 steel and C4 steel) were evaluated. Since concrete bridge decks in Texas vary in thickness from 6.75 in. (17.1 cm) to 8.75 in. (22.2 cm) and in amount of reinforcement, the deck was not considered at this time to limit the capacity of the bridge rail.

From this analysis it appears that the following conclusions can be drawn.

1. All six rails (T101, T201, T202, T5, T4, and C4) can restrain and redirect 4500 lb (2041 kg) passenger cars at 60 mph (97 kph) and 25 degree angle.
2. The combination metal rail and concrete parapet C4 and concrete parapet T5 bridge rails should restrain and redirect a school bus at 60 mph (97 kph) and 15 degrees. The weaker and lower combination T4 rail and the T101 metal rail are also probably capable of restraining and redirecting a school bus.

3. The combination C4 and concrete parapet T5 bridge rails have a chance of redirecting a large intercity bus at 60 mph (97 kph) and 15 degrees.
4. None of the six rails evaluated appear to have a chance of redirecting a loaded, high center of gravity, HS20-44 tractor-trailer at 60 mph (97 kph) and 15 degrees.

All of these conclusions should be confirmed by full-scale crash tests since they are based on relatively simple theory applied to a very complex problem.

DISCLAIMER

The contents of this report reflect the views of the authors who are responsible for the opinions, findings and conclusions presented herein. The contents do not necessarily reflect the official views or policies of the Federal Highway Administration. This report does not constitute a standard, specification, or regulation.

KEY WORDS

Bridge Rails, Traffic Barriers, Highway Safety, Heavy Vehicles

ACKNOWLEDGMENTS

This research study was conducted under a cooperative program between the Texas Transportation Institute (TTI), the State Department of Highways and Public Transportation (SDHPT) and the Federal Highway Administration (FHWA). Mr. John F. Nixon (Engineer of Research, SDHPT) and Mr. John J. Panak (Supervising Designing Engineer, SDHPT) were closely involved in all phases of this study. Mr. Robert L. Reed (Engineer of Bridge Design, SDHPT) also provided guidance and direction to the work.

IMPLEMENTATION STATEMENT

As of the writing of this report none of the findings or conclusions presented have been implemented.

TABLE OF CONTENTS

	<u>Page</u>
ABSTRACT	ii
DISCLAIMER	v
KEY WORDS	v
ACKNOWLEDGMENTS	v
IMPLEMENTATION STATEMENT	v
TABLE OF CONTENTS	vi
LIST OF FIGURES	viii
LIST OF TABLES	ix
INTRODUCTION	1
DESIGN VEHICLES	3
STRENGTH REQUIREMENTS OF BRIDGE RAILS	9
HEIGHT REQUIREMENTS OF BRIDGE RAILS	15
STRUCTURAL STRENGTH EVALUATION OF BRIDGE RAILS	20
METAL RAIL	20
CONCRETE PARAPET RAIL	25
COMBINATION CONCRETE PARAPET AND METAL RAIL	28
STRENGTH EVALUATION OF TEXAS BRIDGE RAILS	32
METAL RAIL - T101 STEEL	32
CONCRETE PARAPET RAIL - T201	35
CONCRETE PARAPET RAIL - T5	37
CONCRETE PARAPET RAIL - T202	37
COMBINATION CONCRETE PARAPET AND METAL RAIL - T4 STEEL	40
COMBINATION CONCRETE PARAPET AND METAL RAIL - C4 STEEL	42
DISCUSSION OF RESULTS	45
SUMMARY	47

TABLE OF CONTENTS (continued)

	<u>Page</u>
CONCLUSIONS	50
REFERENCES	51
APPENDIX "A" COMPUTATION OF LATERAL IMPACT FORCES	52
APPENDIX "B" YIELD LINE ANALYSIS OF CONCRETE PARAPET WALL AND OPEN CONCRETE WALL	57
APPENDIX "C" CALCULATIONS FOR STRENGTH EVALUATION OF SIX TEXAS BRIDGE RAILS	63

LIST OF FIGURES

<u>Figure</u>		<u>Page</u>
1	BRIDGE RAIL DESIGN CAR	4
2	BRIDGE RAIL DESIGN SCHOOL BUS	5
3	BRIDGE RAIL DESIGN BUS	6
4	BRIDGE RAIL DESIGN TRUCK	8
5	MATHEMATICAL MODEL OF VEHICLE-BARRIER RAILING COLLISION	10
6	SUMMARY OF RIGID TRAFFIC RAIL IMPACT FORCES	14
7	APPROXIMATE ANALYSIS OF REQUIRED BRIDGE RAIL EFFECTIVE HEIGHT TO PREVENT VEHICLE FROM ROLLING OVER RAIL	16
8	COMPARISON OF REQUIRED EFFECTIVE HEIGHT TO VEHICLE CENTER OF GRAVITY HEIGHT FOR FOUR SELECTED VEHICLES	17
9	HEAVY VEHICLE ROLLOVER VAULTING POTENTIAL FOR VARIOUS BARRIER HEIGHTS	19
10	THREE TYPES OF BRIDGE RAILS	21
11	DISTRIBUTION OF IMPACT LOAD IN COLLISION WITH LONGITUDINAL TRAFFIC RAIL	23
12	POSSIBLE FAILURE MODES FOR METAL RAILS	24
13	YIELD LINE ANALYSIS OF CONCRETE PARAPET WALL	26
14	YIELD LINE ANALYSIS OF OPEN CONCRETE WALL OR PARAPET	27
15	COMBINATION CONCRETE WALL AND METAL RAIL EVALUATION-IMPACT AT MID-SPAN OF RAIL	29
16	COMBINATION CONCRETE WALL AND METAL RAIL EVALUATION-IMPACT AT POST	30
17	TEXAS T101 STEEL BRIDGE RAIL	33
18	TRAFFIC RAIL BARRIER TYPE T201	36
19	TRAFFIC RAIL BARRIER TYPE T5	38
20	TRAFFIC RAIL TYPE T202	39
21	TRAFFIC RAIL BARRIER TYPE T4	41
22	TRAFFIC RAIL BARRIER TYPE C4	43

LIST OF TABLES

<u>Table</u>		<u>Page</u>
1	TABULATION OF RIGID TRAFFIC RAIL LATERAL IMPACT FORCES	13

INTRODUCTION

The recent multiple fatality anhydrous ammonia truck-bridge rail accident in Houston, Texas^{(1)*}, and the school bus-bridge rail accident near Martinez, California (2), emphasizes the need for a bridge rail to contain heavy trucks and buses. Present bridge rails are only designed to restrain and redirect passenger cars up to 4500 lb (2041 kg) in weight traveling 60 mph (97 kph) and impacting the rail at a 25° angle (3). The current bridge rails must be at least 27 in. (69 cm) high and be able to resist a static load of 10,000 lb (4536 kg) without exceeding a specified allowable working stress based on an elastic analysis (4).

Bridge rails designed in accordance with the present criteria have in general performed well in restraining passenger cars. Recent truck and Concrete Median Barrier (CMB) crash tests (6) have indicated that some of our traffic rails designed by the present criteria have considerable reserve strength and are capable of redirecting heavy buses and trucks.

The objective of the report is to present an analytical evaluation of the capabilities of standard Texas bridge rails to contain automobiles, buses and trucks. This evaluation consists of an analysis of the strength of the bridge rails to determine if they are strong enough to resist the impact forces. In addition, an analysis was made to determine if they are high enough to prevent high center of gravity buses and trucks from rolling over the rails. After the bridge rail analytical evaluation is completed State Department of Highway and Public Transportation (SDHPT) engineers and Texas Transportation Institute (TTI) research engineers will select the

*Numbers in parentheses refer to corresponding item in Reference List.

most promising rail for potential modification and subject it to full-scale crash tests with a bus and/or truck.

In order to analytically evaluate the Texas bridge rails, the following tasks were performed and are reported herein:

1. Select Typical Design Vehicles - Dimensions, Weight, Height of Center of Gravity, etc.
2. Determine Barrier or Bridge Rail Impact Force Required to Redirect the Selected Vehicles.
3. Determine Height of Barrier or Bridge Rail Required to prevent Selected Vehicles from Rolling over during Redirection.
4. Determine Maximum Strength or Resisting Force Capability of Selected Texas Bridge Rails and the Effective Height of these Rails.
5. Compare Bridge Rail Capabilities of Item 4 to Requirements of Items 2 and 3.

DESIGN VEHICLES

The "Recommended Procedures for Vehicle Crash Testing of Highway Appurtenances" (3) recommends that a longitudinal traffic barrier or rail be capable of redirecting a 4500 lb (2041 kg) automobile traveling at 60 mph (97 kph) and impacting at a 25⁰ angle. Typical dimensions of such a vehicle are shown on Figure 1. The center of gravity of full-size American passenger cars is located about 20 to 24 in. (51 to 61 cm) above the roadway and slightly forward of mid-length. As will be shown later, these dimensions are required to compute the average impact force of a vehicle striking a longitudinal traffic rail.

Figure 2 shows the typical dimensions of a typical American 66-passenger school bus. Such buses weigh about 13,000 lb (5897 kg) empty and about 20,000 lb (9702 kg) when loaded. The center of gravity of such loaded vehicles will vary from 50 to 60 in. (127 to 153 cm) above the roadway. An interesting characteristic of such buses is that the 66-passengers or 7000 lb (3175 kg) of load is moveable and can shift during violent vehicle impact. School bus crash tests have demonstrated this behavior. The school bus was selected as a design vehicle because it is quite numerous on our highways and has been involved in some spectacular and widely publicized accidents with traffic rails (2).

The next heaviest and very common vehicle which has been selected as a design vehicle is a large intercity bus. A typical large intercity bus is shown in Figure 3. They will weigh from 30,000 to 40,000 lb (13,608 to 18,144 kg) when loaded with up to 45 passengers and baggage or freight. The center of gravity of such vehicles will vary from 52 to 64 in. (132 to 163 cm).

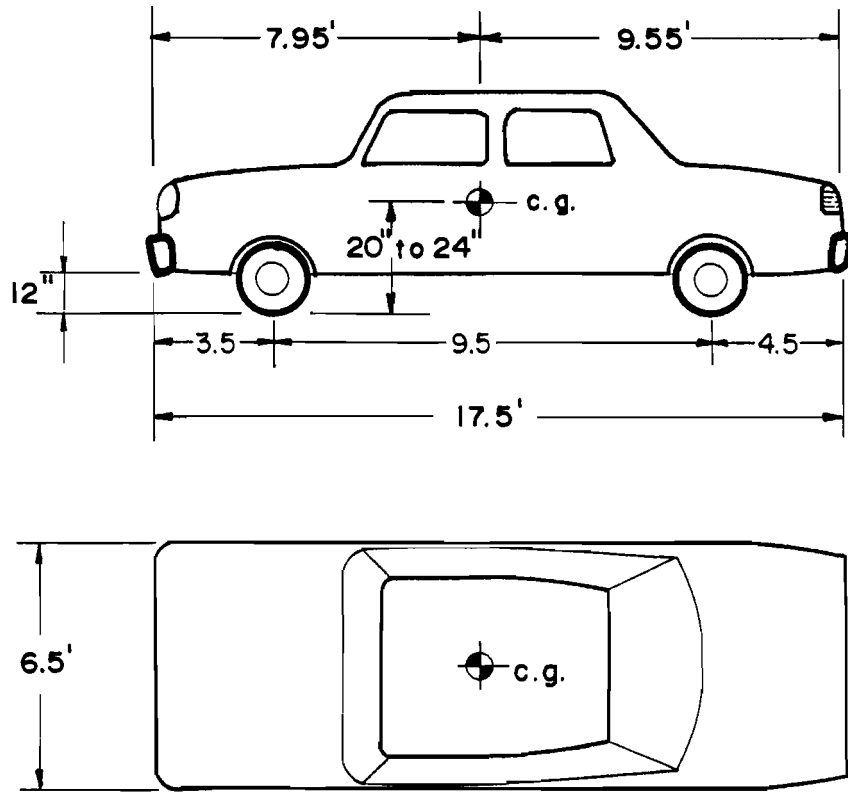

4500 lb PASSENGER CAR

NOTE: 1 lb = .4536 kg
 1 in. = 2.54 cm
 1 ft = .3048 m

FIGURE I. BRIDGE RAIL DESIGN CAR.

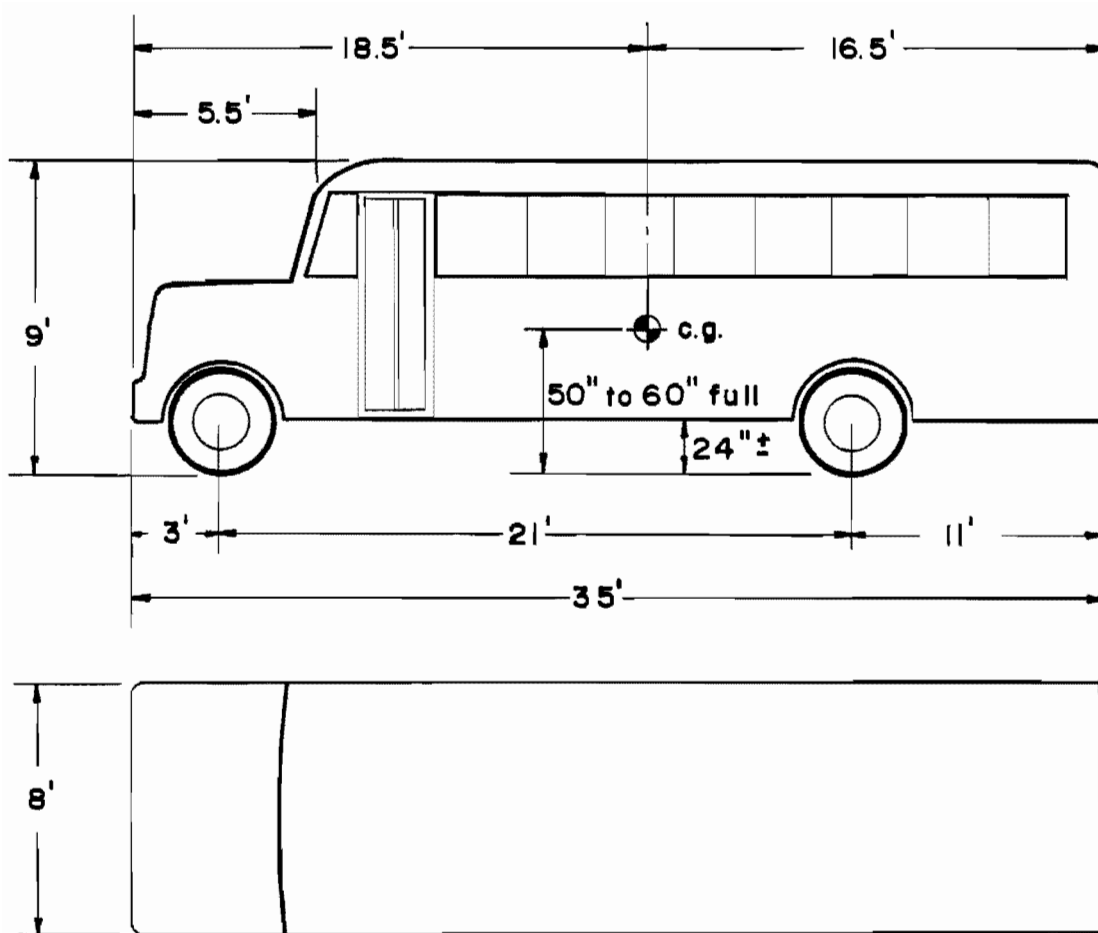

NOTE: 1 lb. = .4536 kg
 1 in. = 2.54 cm
 1 ft = .3048 m

TYPICAL 66 PASSENGER SCHOOL BUS

TOTAL WEIGHT = 20,000 lbs.

Empty 12,800 lb — CG = 44" to 60"

Passengers 7,200 lb — CG = 60" ± — (Avg. 109 lb passenger)

20,000 lb — CG = 50" to 60"

FIGURE 2. BRIDGE RAIL DESIGN SCHOOL BUS.

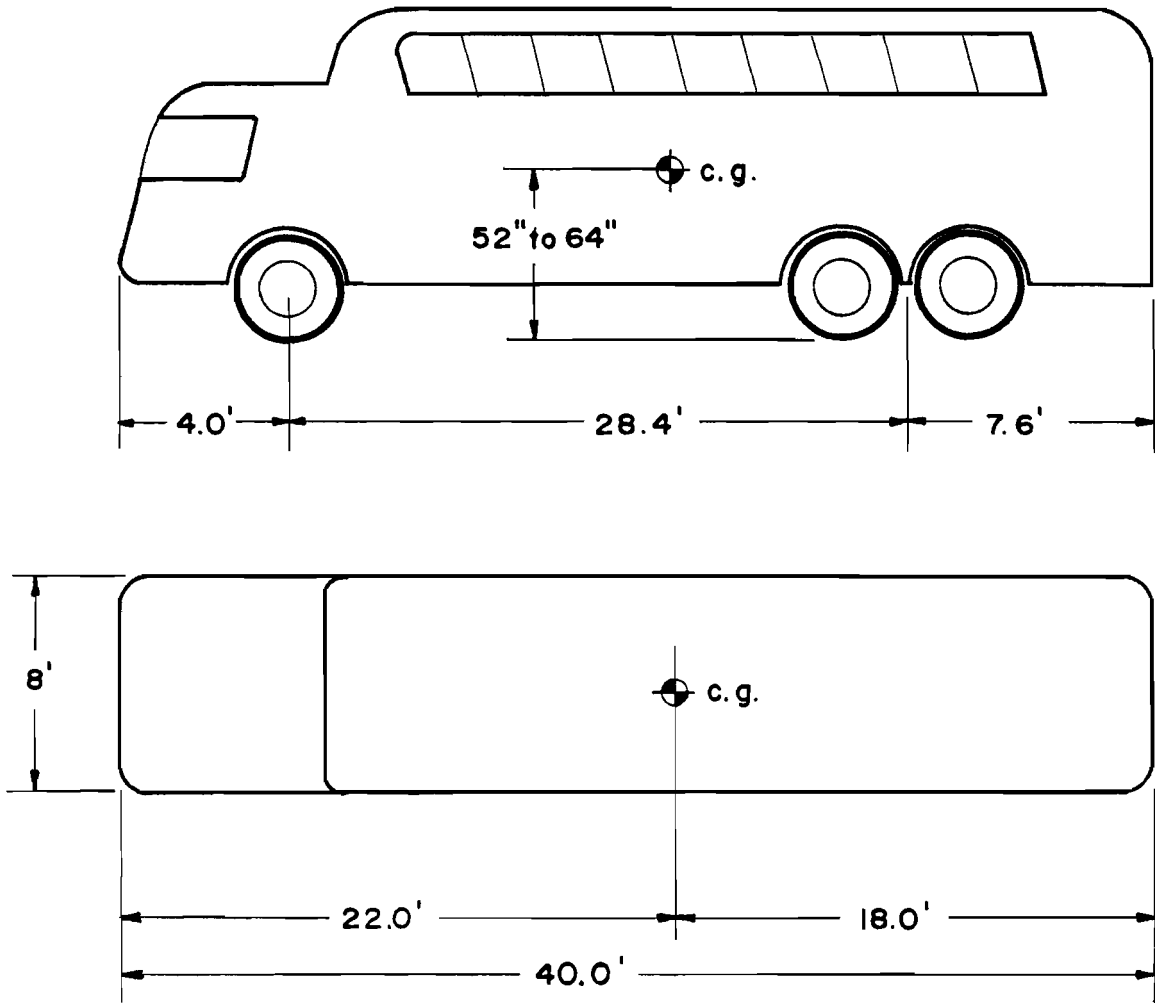

40,000 lb LARGE INTERCITY BUS
 LENGTH 40ft WIDTH 8ft
 LOCATION OF C.G. IS 22 ft FROM FRONT
 45 PASSENGER

NOTE: 1 lb = .4536 kg
 1 in = 2.54 cm
 1 ft = .3048 m

FIGURE 3. BRIDGE RAIL DESIGN BUS.

The heaviest design vehicle selected was a tractor-trailer with weight distribution and dimensions similar to an AASHTO HS20-44 design truck. This vehicle is shown by Figure 4 and is typical of such 72,000 lb (32,659 kg) vehicles operating on our highways. The height of the center of gravity (c.g.) of these vehicles varies widely. The tractor typically has a c.g. height of about 45 in. (114 cm) while trailer c.g. may go up to 78 in. (198 cm) or more.

In summary, this analytical evaluation will consider four sizes or types of vehicles as follows:

1. passenger cars up to 4500 lb (2041 kg);
2. vans, recreational vehicles, and school buses up to 20,000 lb (9702 kg);
3. large intercity buses up to 40,000 lb (18,144 kg); and
4. large tractor-trailers up to 72,000 lb (32,659 kg).

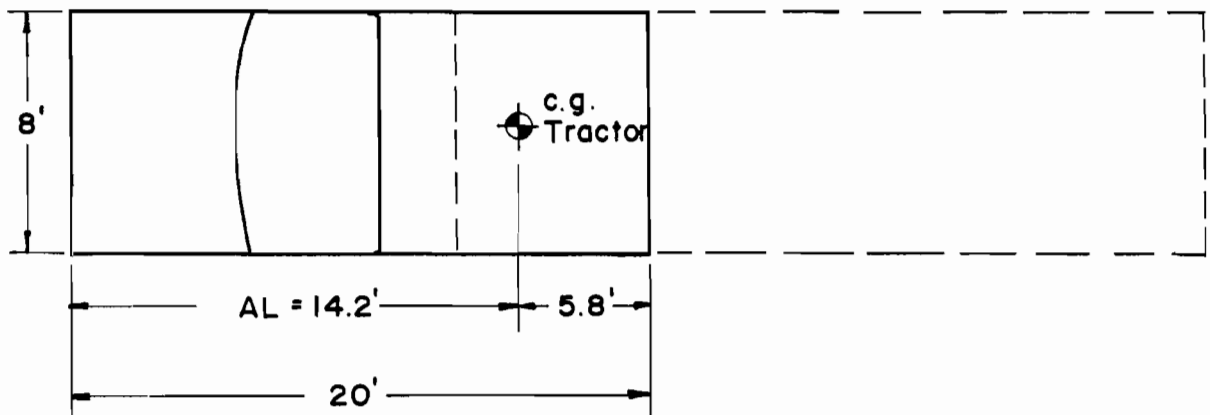
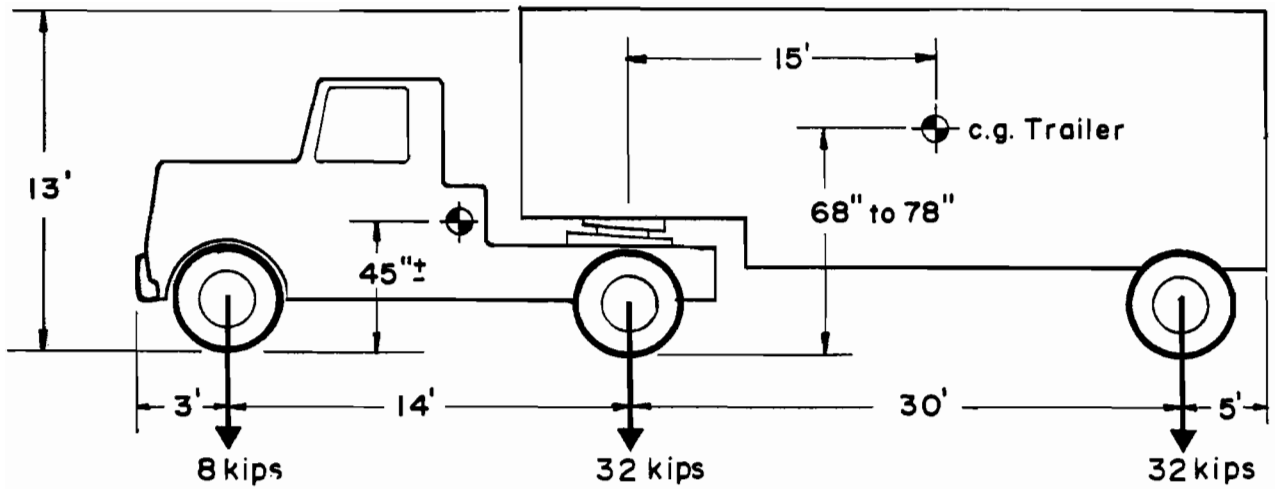

40,000 lb TRACTOR OF SEMI-TRAILER

LENGTH 20ft. WIDTH 8ft.

LOCATION OF C.G. IS 14.2 ft. FROM FRONT

AASHTO HS 20-44 DESIGN TRUCK

NOTE: 1 lb = .4536 kg

1 in. = 2.54 cm

1 ft = .3048 m

1 mph = 1.609 km/hr

FIGURE 4. BRIDGE RAIL DESIGN TRUCK

STRENGTH REQUIREMENTS OF BRIDGE RAILS

Now that the design vehicles and their characteristics have been established, the impact forces that they impose on a bridge or traffic rail can be predicted. The method used to predict the impact forces are the equations presented in NCHRP Report 86 (7).

Figure 5 illustrates a vehicle impacting a longitudinal traffic rail at an angle θ . From this illustration of the impact event it can be shown that the average lateral vehicle deceleration (G_{lat}) is

$$\text{Avg } G_{lat} = \frac{V_I^2 \sin^2(\theta)}{2g\{AL \sin(\theta) - B[1 - \cos(\theta)] + D\}} \quad \text{Eq. 1}$$

If the stiffness of the vehicle and rail could be idealized as a linear spring the impact force-time curve would be in the shape of a sine curve then the peak or maximum lateral vehicle deceleration ($\max G_{lat}$) would be

$$\max G_{lat} = \frac{\pi}{2} (\text{avg } G_{lat}) \quad \text{Eq. 2}$$

The lateral impact force (F_{lat}) on the traffic rail would then be equal to the lateral vehicle deceleration times the vehicle weight, thus

$$\text{avg } F_{lat} = (\text{avg } G_{lat})W \quad \text{Eq. 3}$$

and

$$\max F_{lat} = \frac{\pi}{2} (\text{avg } F_{lat}) \quad \text{Eq. 4}$$

INSTANT OF VEHICLE-BARRIER
RAILING COLLISION

INSTANT VEHICLE BECOMES
PARALLEL TO UNDEFORMED
BARRIER RAILING

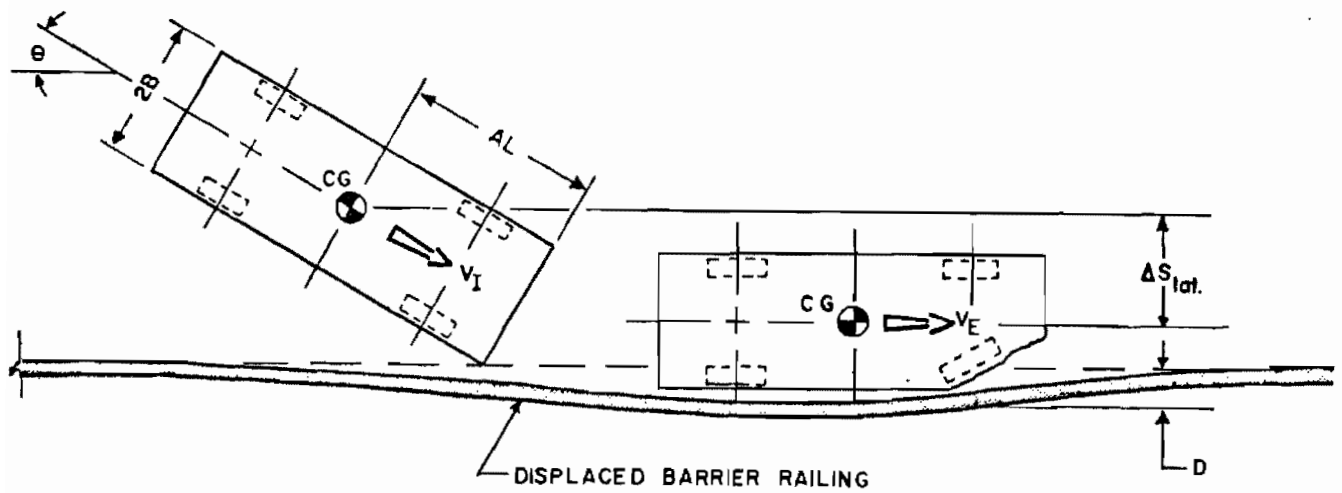

FIGURE 5. MATHEMATICAL MODEL OF VEHICLE - BARRIER
RAILING COLLISION. (AFTER NCHRP 86, Ref. 7).

One could determine the longitudinal forces on the rail by multiplying the lateral forces times the coefficient of friction (μ) between the vehicle and rail. The symbols used are defined as follows:

L = vehicle length (ft);

$2B$ = vehicle width (ft);

D = lateral displacement of barrier railing (ft)

assumed as zero for rigid rail;

AL = distance from vehicle's front end to center of mass (ft);

V_I = vehicle impact velocity (fps);

V_E = vehicle exit velocity (fps);

θ = vehicle impact angle (deg);

μ = coefficient of friction between vehicle body and barrier railing;

a = vehicle deceleration (ft/sec²);

g = acceleration due to gravity (ft/sec²);

m = vehicle mass (lb-sec²/ft); and

W = vehicle weight (lb).

These equations express the average vehicle decelerations as a function of: (1) type of barrier railing -- rigid or flexible, (2) dimensions of the vehicle, (3) location of the center of mass of the vehicle (4) impact speed of vehicle, (5) impact angle of the vehicle, and (6) coefficient of friction between the vehicle body and barrier railing. When computed deceleration values from these equations were compared with full-scale vehicle crash test data, it was found that these equations predict the behavior of standard size passenger vehicles to an accuracy of ± 20 percent.

Such a comparison is remarkable when one considers the simplicity of the model and the difficulties involved in acquiring and reducing data

obtained from full-scale dynamic tests (7).

In Appendix A these equations were used to compute the lateral impact forces a vehicle would impose on a rigid traffic rail or bridge rail.

An estimate of the vehicle impact forces on a traffic rail was also obtained from Bloom, Rudd and Labra (9). In addition to this, estimates were also obtained from Buth (10) using data obtained from an ongoing FHWA sponsored research contract.

A tabulation of all these data is contained in Table 1 and summarized for practical use in Figure 6. Bloom's maximum force data were determined by using the BARRIER VII computer program and is the cumulative barrier force over the impact area and not a single point load. Buth's impact force was obtained experimentally by taking the maximum 50 msec lateral vehicle deceleration and multiplying by the vehicle weight. This value was then adjusted upward to account for barrier deformation in certain cases.

It is believed that the impact forces indicated by Bloom's and Buth's data are an upper bound for perfectly rigid barriers, and that the forces produced by Equation 4 is a lower bound. Consequently it is concluded that to restrain and redirect a school bus at 60 mph (96.5 km/hr) and 15 degrees a bridge rail must be able to resist an impact force of from 55 to 85 kips. In order to redirect an intercity bus under similar conditions, a bridge rail must be able to resist an impact force of from 90 to 150 kips. In order to redirect a heavy HS20-44 truck-trailer under similar conditions a rail must be able to resist an impact force of from 140 to 250 kips. These estimates are for rigid rails which should be conservative since most such structures will deform somewhat.

TABLE 1. TABULATION OF RIGID TRAFFIC RAIL LATERAL
 IMPACT FORCES.
 (All impacts at 60 mph (96.5 km/hr) and 15 degree angle)

VEHICLE WEIGHT lb	AVERAGE FORCE kips	MAXIMUM FORCE kips		
	Eq. 3	Eq. 4	Bloom (9)	Butt (10)
4,500 Car	19	29	30	28
20,000 School Bus	35	55	70	84
40,000 Inter- city Bus	58	91	150	150
70,000 Truck Concrete	--	--	250	--
72,000 Truck HS20-44	91	143	--	--

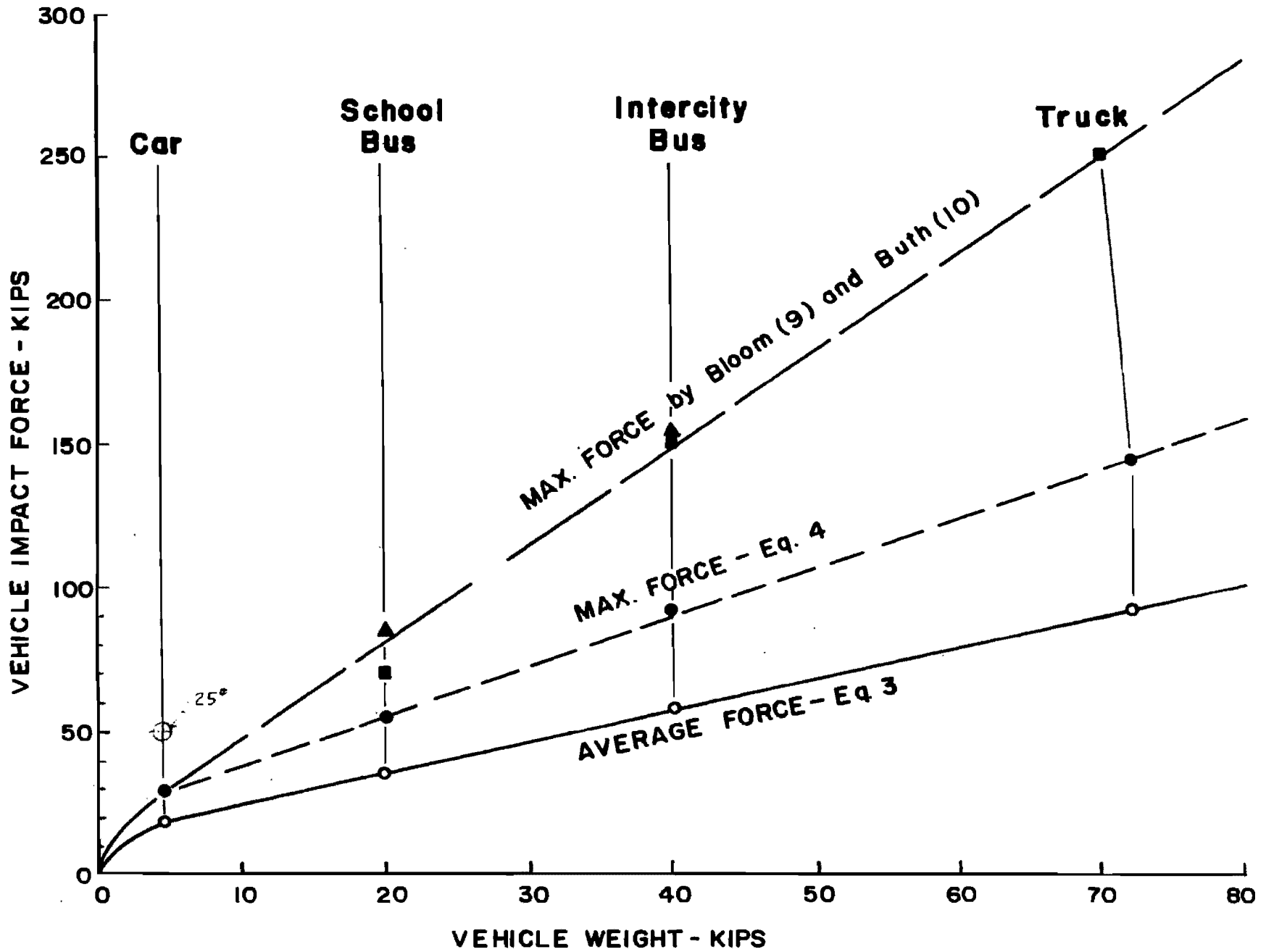

FIGURE 6. SUMMARY OF RIGID TRAFFIC RAIL IMPACT FORCES
60 mph (96.5 km/hr) - 15 degree angle

HEIGHT REQUIREMENTS OF BRIDGE RAILS

The previous chapter presented data on the magnitude of the lateral impact forces that a bridge rail would be subjected to. While a bridge must be strong enough to restrain and redirect a vehicle it must also be high enough to prevent the vehicle from rolling over it.

Figure 7 shows a rear or front view of a vehicle impacting a longitudinal rail. The force F_{lat} is the resisting force of the rail which would be located at the centroid of the rail member or top of a concrete parapet. The height (H) of this resisting force is defined as the effective height of the rail. For example the top of a standard 12 in. (30.5 cm) deep W-beam guardrail is mounted 27 in. (69 cm) high in Texas; however, its effective height (H) would only be 21 in. (53 cm).

In many cases the center of gravity (CG) of an impacting vehicle may be much higher (C) than the effective height (H) of the rail. The vehicle does not necessarily roll over the rail in this case because a stabilizing moment equal to the weight of the vehicle (W) times one half the width of the vehicle (B/2) is also acting on the vehicle. Equations 5 and 6 shown on Figure 7 present equations which indicate the approximate effective height required for a bridge rail to prevent a vehicle from rolling over it. This effective height is a function of the lateral impact deceleration of the vehicle, height of vehicle center of gravity, width of vehicle, and pavement-tire friction in this simplified math model.

Figure 8 presents a comparison of the required effective height of a longitudinal rail to the center of gravity height for four selected design vehicles. From Figure 8 it can be seen that to prevent a large passenger

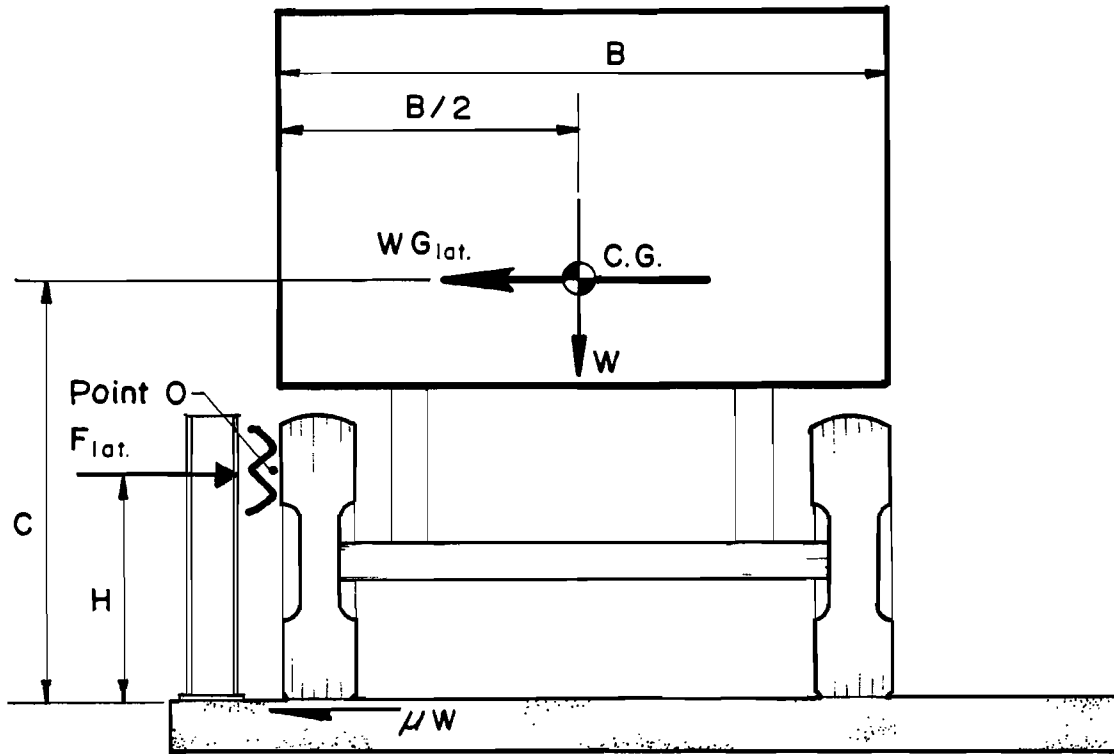

W = weight of vehicle

G_{lat} = avg. lateral deceleration of vehicle from Eq. 1

μ = coef. of pavement friction ≈ 0 to 0.39

C = height to vehicle c.g., in.

H = effective height of barrier rail, in.

O = center of overturning rotation located at centroid of rail or top of concrete parapet

B = width of vehicle, in.

F_{lat} = resisting railing force located at effective rail height

$$M_o = WG_{lat}(C-H) - WB/2 - \mu WH = 0$$

$$H = \frac{G_{lat} C - B/2}{\mu + G_{lat}} \quad (\text{Eq. 5})$$

NEGLECTING FRICTION,

$$H = \frac{G_{lat} C - B/2}{G_{lat}} \quad (\text{Eq. 6})$$

FIGURE 7. APPROXIMATE ANALYSIS OF REQUIRED BRIDGE RAIL EFFECTIVE HEIGHT TO PREVENT VEHICLE FROM ROLLING OVER RAIL.

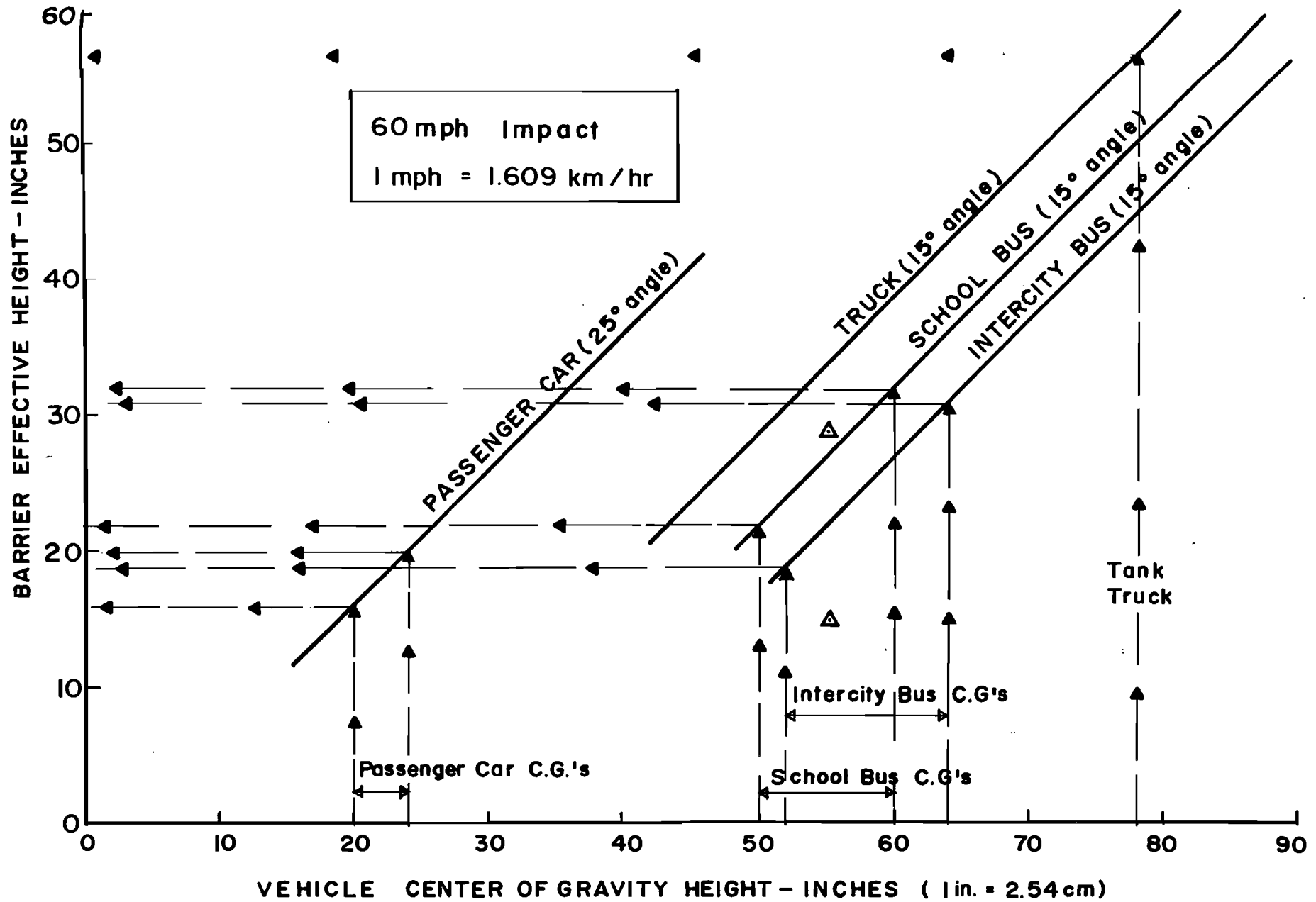

Figure 8. COMPARISON OF REQUIRED EFFECTIVE HEIGHT TO VEHICLE CENTER OF GRAVITY HEIGHT FOR FOUR SELECTED VEHICLES-large passenger car, school bus, intercity bus, and HS20-44 truck.

car with CG from 20 to 24 in. (41 to 61 cm) from rolling over the rail, an effective height of 16 to 20 in. (41 to 51 cm) is required. As mentioned previously, the standard guardrail in Texas has an effective height of 21 in. (53 cm). To prevent a school bus with CG of 50 to 60 in. (127 to 152 cm) from rolling over, the rail would require an effective height of from 22 to 32 in. (56 to 81 cm). As can be seen, an intercity bus would require rails of similar effective heights. A large tank truck similar to the anhydrous ammonia truck in the Houston accident with a 78 in. (198 cm) CG would require an effective height rail of around 57 in. (145 cm).

Effective barrier height requirements indicated by Figure 8 are believed to be reasonable. Figure 9 shows similar data developed by Bloom, Rudd and Labra (9) using a more sophisticated math model. These data on Figure 9 indicate a truck with a 55 in. (140 cm) CG would require a 29 in. (74 cm) effective barrier height. An intercity bus with a similar CG would require 15 in. (38 cm) effective barrier height. These two data points are presented on Figure 8 by triangles. Recent crash test results from Buth (10) and others seem to indicate Figure 8 (or Eq. 6) yield more reasonable results.

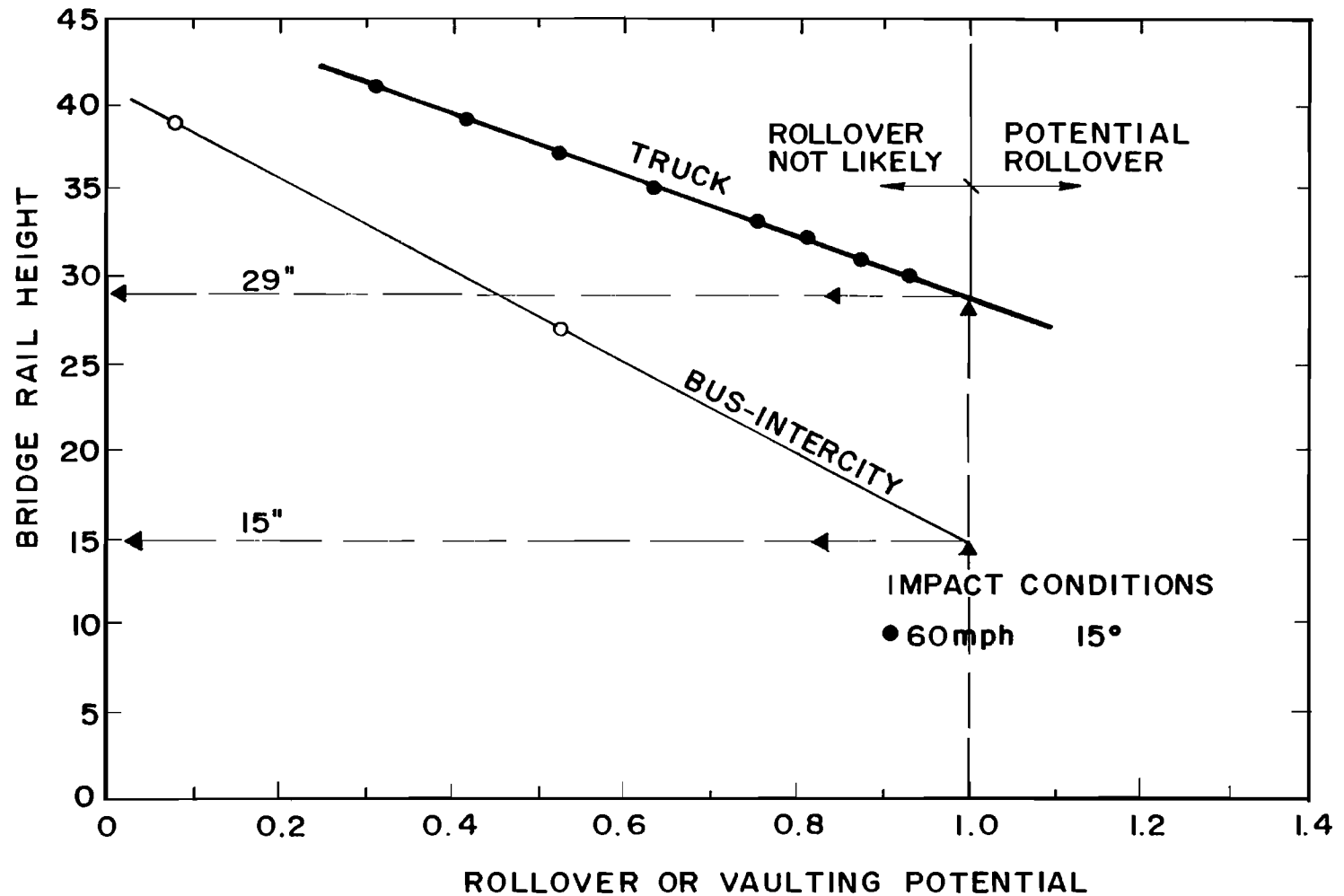

FIGURE 9. HEAVY VEHICLE ROLLOVER VAULTING POTENTIAL FOR VARIOUS BARRIER HEIGHTS. Data from Report No. FHWA-RD-75-47 (Ref. 9) 40,000 lb Single Unit Truck & Bus; 55 in. C.G. Height.

STRUCTURAL STRENGTH EVALUATION OF BRIDGE RAILS

The strength and effective height requirements of bridge rails have now been defined approximately. The next step is to determine the ultimate strength capacity and effective height of various bridge rail designs used in Texas. At present there appear to be three different types of bridge rails as shown in Figure 10. The three types are as follows:

1. Metal Rail which consists of five basic structural elements that work together to produce the ultimate strength of the system -- rail, posts, base plate, anchor bolts and bridge deck;
2. Concrete Parapet which consists of a reinforced concrete wall mounted on the concrete bridge deck;
3. Combination Concrete Parapet and Metal Rail which consists of six basic structural elements that work together to produce the ultimate strength of the system -- rail, posts, anchor bolts, concrete wall and concrete bridge deck.

The general method of analyzing each of these rail types in order to determine their ultimate strength will now be briefly described.

METAL RAIL

The method of evaluating the ultimate strength of these rails utilized the well known "Plastic Analysis Method" for the rail or beam element. The maximum stress which could be developed in the rail was the yield strength of the metal. For the post, anchor bolts and base plate, however, a modified plastic analysis method was used whereby the ultimate strength of the metal

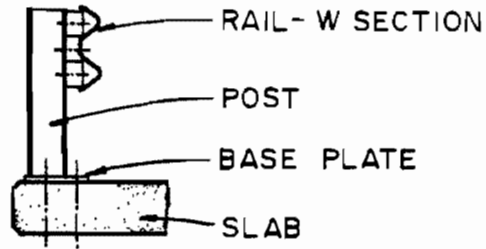

(A) METAL RAIL - anchor bolts, base plate, post, rail and bridge deck.

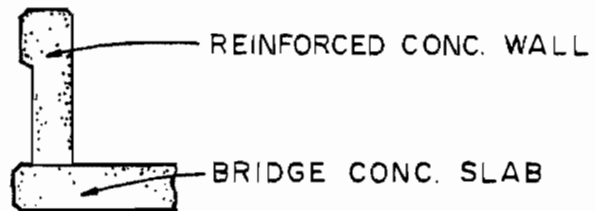

(B) CONCRETE PARAPET - concrete wall and slab.

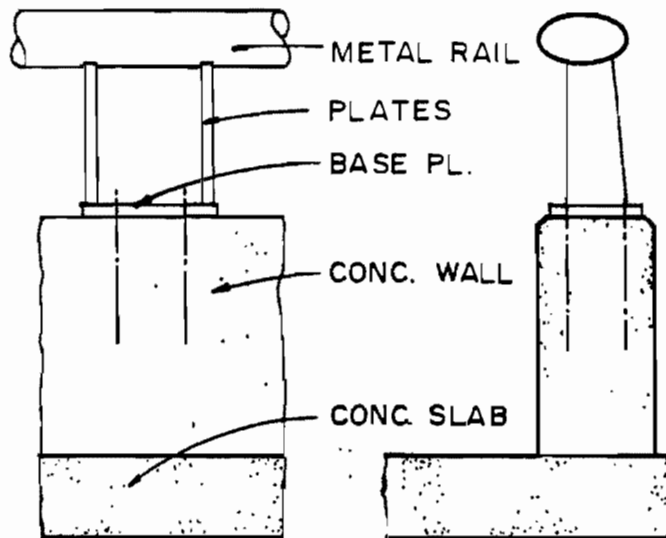

(C) COMBINATION CONCRETE PARAPET AND METAL RAIL - metal rail, post, base plate, anchor bolt, concrete wall and slab.

FIGURE 10. THREE TYPES OF BRIDGE RAILS.

was used instead of the yield strength. Static load tests of welded bridge rail posts indicated their ultimate moment capacity was the plastic section modulus times the ultimate strength of the steel (11). This is possible because at the point of maximum moment the post is welded to the base plate.

When a vehicle impacts a longitudinal traffic rail at an angle, the sheet metal is crushed as shown in Figure 11. Crash tests have shown this crush length ℓ to be about 3 to 4 ft (.91 to 1.22 m) for automobiles. If a truck or bus impacts a rail, a similar crush takes place. In some cases only the front tire of a school bus or truck will contact the rail. Since these large tires are about 3.5 ft (1.07 m) in diameter, it is reasonable to assume the load is distributed over a length $\ell=3.5$ ft (1.07 m). This length will be used in the analysis of both metal and concrete rails.

In order to determine the total ultimate vehicle impact load ($w\ell$), a bridge rail system can resist several possible failure modes which must be considered, as shown in Figure 12. Failure modes similar to these have been observed in actual crash tests. When a "weak beam-strong post" system is used, single or two span failure modes have been observed. When a "strong beam-strong post" system is used, three span failure modes have been observed. All possibilities should be considered in the analysis.

w = distributed load, lb/ft or N/m
 l = length of distributed load, ft or m
 wl = total impact load, lb or N

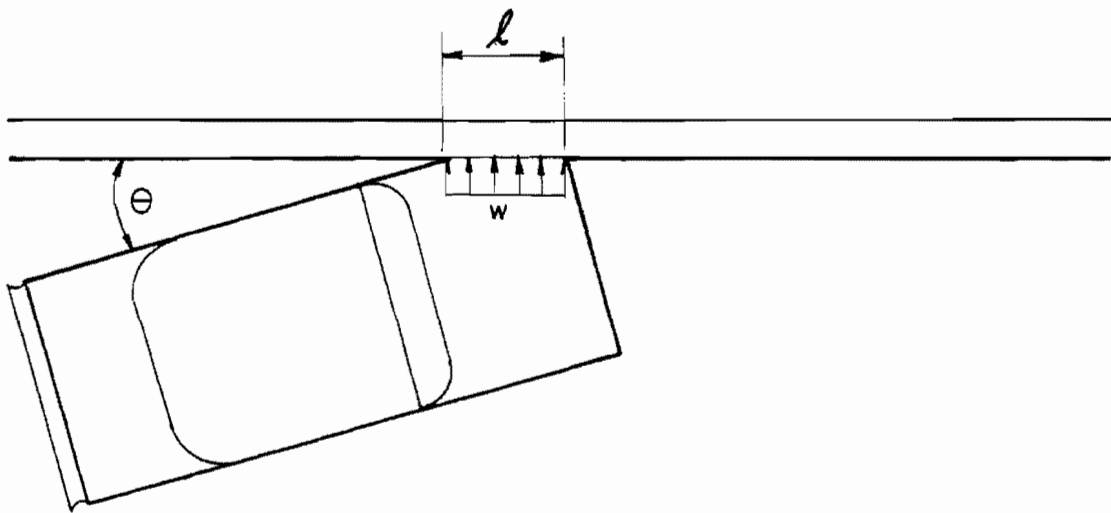
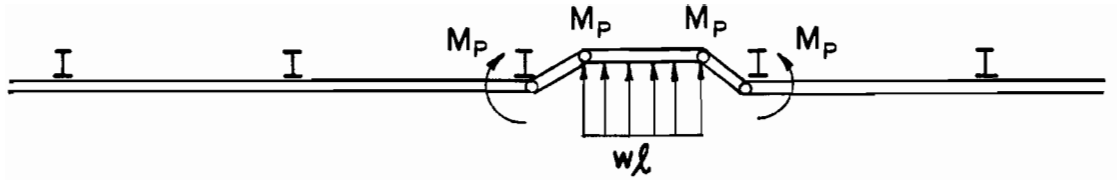
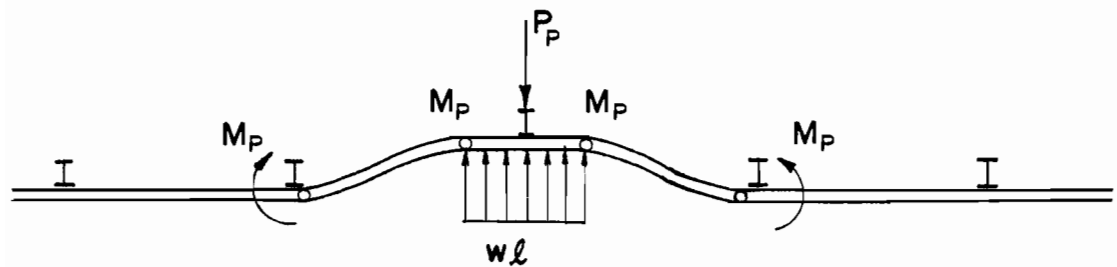

FIGURE II. DISTRIBUTION OF IMPACT LOAD IN COLLISION WITH LONGITUDINAL TRAFFIC RAIL.



(A) Single Span Failure Mode



(B) Two Span Failure Mode

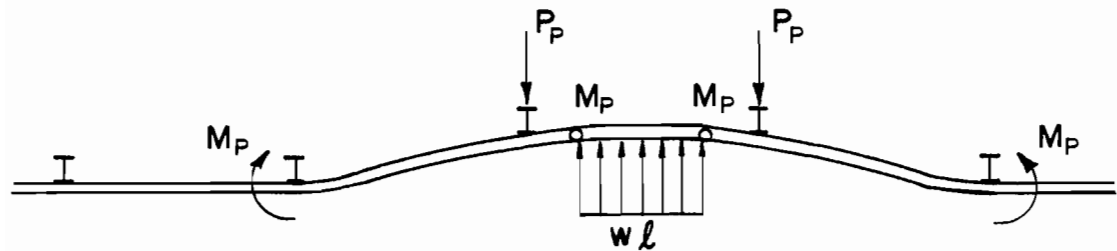

(C) Three Span Failure Mode

M_P = plastic moment capacity of rail

P_P = ultimate load capacity of a single post

wl = total ultimate vehicle impact load

PLAN VIEW

FIGURE 12. POSSIBLE FAILURE MODES FOR METAL RAILS.

CONCRETE PARAPET RAIL

The method of evaluating the ultimate strength of the concrete parapet or wall systems was the "Yield Line Method" as described in advanced textbooks on reinforced concrete. The results of such an analysis on a typical concrete parapet is shown by Figure 13 (see Appendix "B" for complete development of the equations). In this analysis the total ultimate load (wL) was applied at the top of the concrete wall. This is the most critical location and also yields the maximum effective height (H). The critical length (L) is the length which gives the minimum ultimate total load (wL).

It is interesting to note that the ultimate load capacity of the wall is a function of the moment capacity of the beam at the top of the wall (M_b), the moment capacity of the wall (M_w) and the cantilever moment capacity of the wall (M_c). If the bridge deck is weak it may control or limit the cantilever moment capacity (M_c). However, these equations indicate that the total load capacity of the wall can be increased by strengthening the beam and wall by adding more horizontal steel, for example, and this will increase the length (L) and bring more bridge deck into play.

A second type of concrete wall or parapet is shown by Figure 14. This wall has openings or gaps of length (G) spaced at regular intervals along it. This type wall was also evaluated by the "Yield Line Method" and the results presented in Figure 14 and Appendix "B".

The analysis presented here does not consider impacts near open joints (expansion or contraction) in the concrete walls. Such joints, which frequently occur, can be evaluated by modifying the "Yield Line Analysis" presented in Appendix "B". The ultimate strength of the concrete parapet would be about one half the values computed here. To minimize the effect of joints, it is recommended that their use be minimized and that

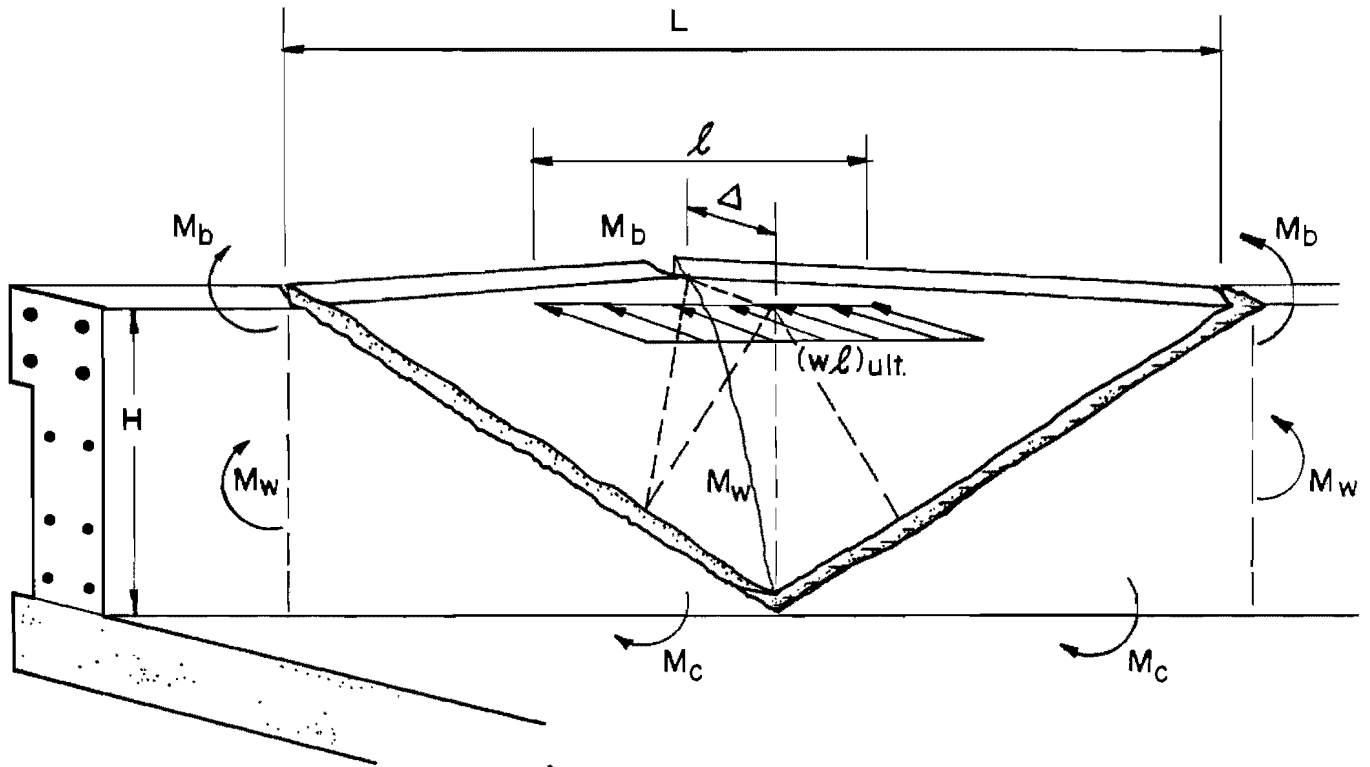

$$(wl) = \frac{8M_b}{L - l/2} + \frac{8M_w H}{L - l/2} + \frac{M_c L^2}{H(L - l/2)}$$

$$L = \frac{l}{2} + \sqrt{\left(\frac{l}{2}\right)^2 + \frac{8H(M_b + M_w H)}{M_c}}$$

H = height of wall, ft

L = critical length of wall failure, ft

wl = total ultimate load capacity of walls, kips

M_b = ultimate moment capacity of beam at top of wall, kip-ft

M_w = ultimate moment capacity of wall per ft of wall height, kip-ft/ft

M_c = ultimate moment capacity of wall cantilever up from bridge deck per ft of length of wall, kip-ft/ft

l = length of distributed impact load, ft

FIGURE 13. YIELD LINE ANALYSIS OF CONCRETE PARAPET WALL

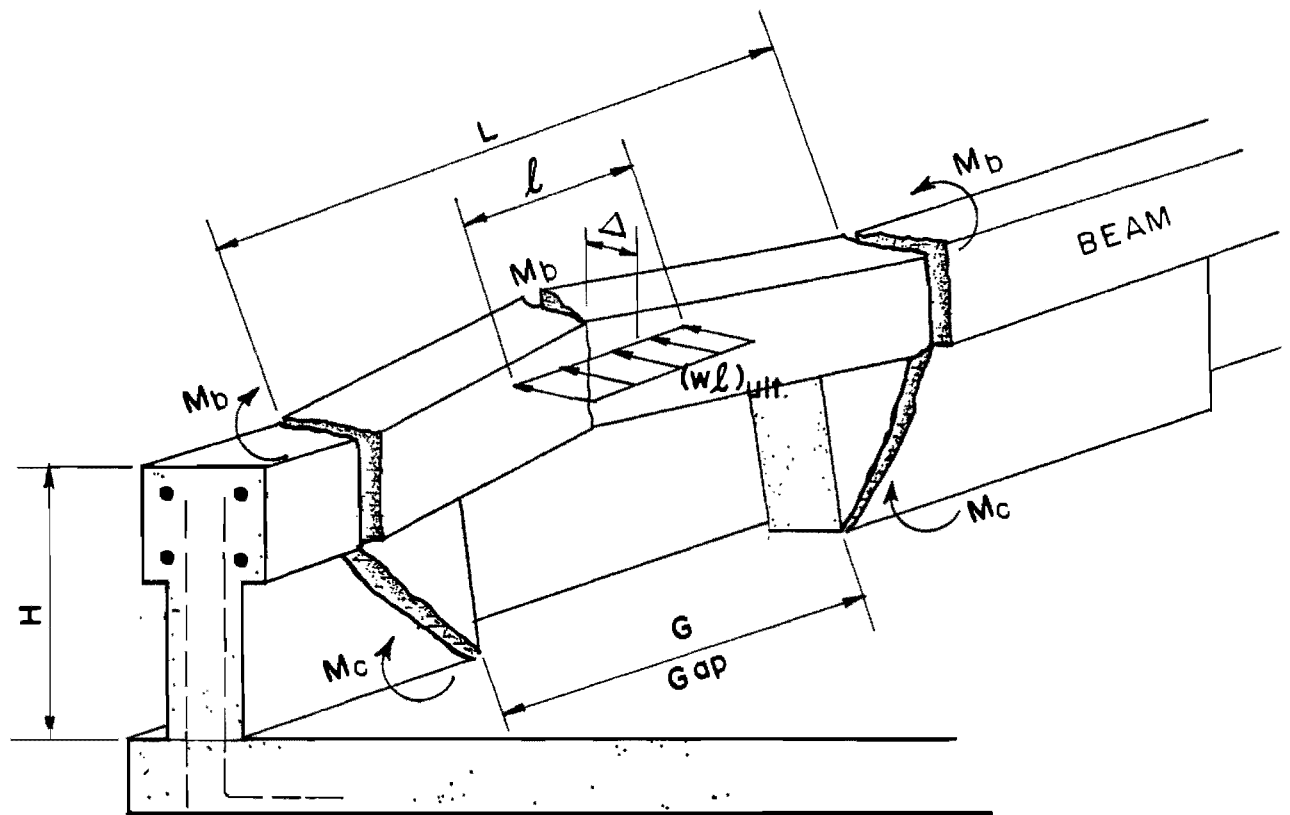

$$(wl)_{ult.} = \frac{8 M_b}{(L - l/2)} + \frac{M_c L (L - G)}{H (L - l/2)}$$

$$L = \frac{l}{2} + \sqrt{\left(\frac{l}{2}\right)^2 + \frac{8 H M_b}{M_c} - \frac{G l}{2}}$$

- l = length of distributed impact load, ft
- wl = total ultimate distributed load capacity of wall
- H = height of wall, ft
- L = critical length of wall failure, ft
- M_b = ultimate moment capacity of beam at top of wall, kip-ft
- M_c = ultimate moment capacity of wall cantilever up from bridge deck per length of wall, kip-ft/ft
- G = length of gap or wall opening, ft

FIGURE 14. YIELD LINE ANALYSIS OF OPEN CONCRETE WALL OR PARAPET.

reinforcing steel be continuous across such joints.

COMBINATION CONCRETE PARAPET AND METAL RAIL

In order to determine the impact resistance capability of a combination bridge rail, the strength of each of its components must be determined as previously described. The bending strength of the rail must be determined over one span (P_R) and over two spans (P'_R). The strength of the post (P_p) on top of the wall must be determined and this could be controlled by the anchor bolts or post section modulus. In addition, the strength of the concrete parapet or wall (P_W) must be determined as previously described (see Appendix "B").

From Figures 15 and 16 there appear to be two possible critical impact points for a combination bridge rail. Each of these must be evaluated and the critical strength determined.

Figure 15 presents an evaluation when the vehicle impact is at mid-span of the metal rail. The bending strength of the rail (P_R) and the maximum strength of the concrete wall (P_W) will add together to yield the maximum resultant strength (R) as shown. The effective height (H) of this resultant (R) is not the height of the rail (h_R) or wall (h_W) but somewhere in between as shown.

Figure 16 shows another possibility of an impact at a post. This is usually the critical impact point which yields the smallest resultant (R). Both cases must be investigated to make sure, however. At the centroid of the metal rail there are two resisting forces, the post strength (P_p) and the rail bending strength over two spans (P'_R), as shown. At the top of the concrete wall we have a reduced wall capacity (P'_W) since the post load is transmitted to the bridge deck at this point also. Consequently, the maximum resultant strength (R) is the sum of the post capacity (P_p), the

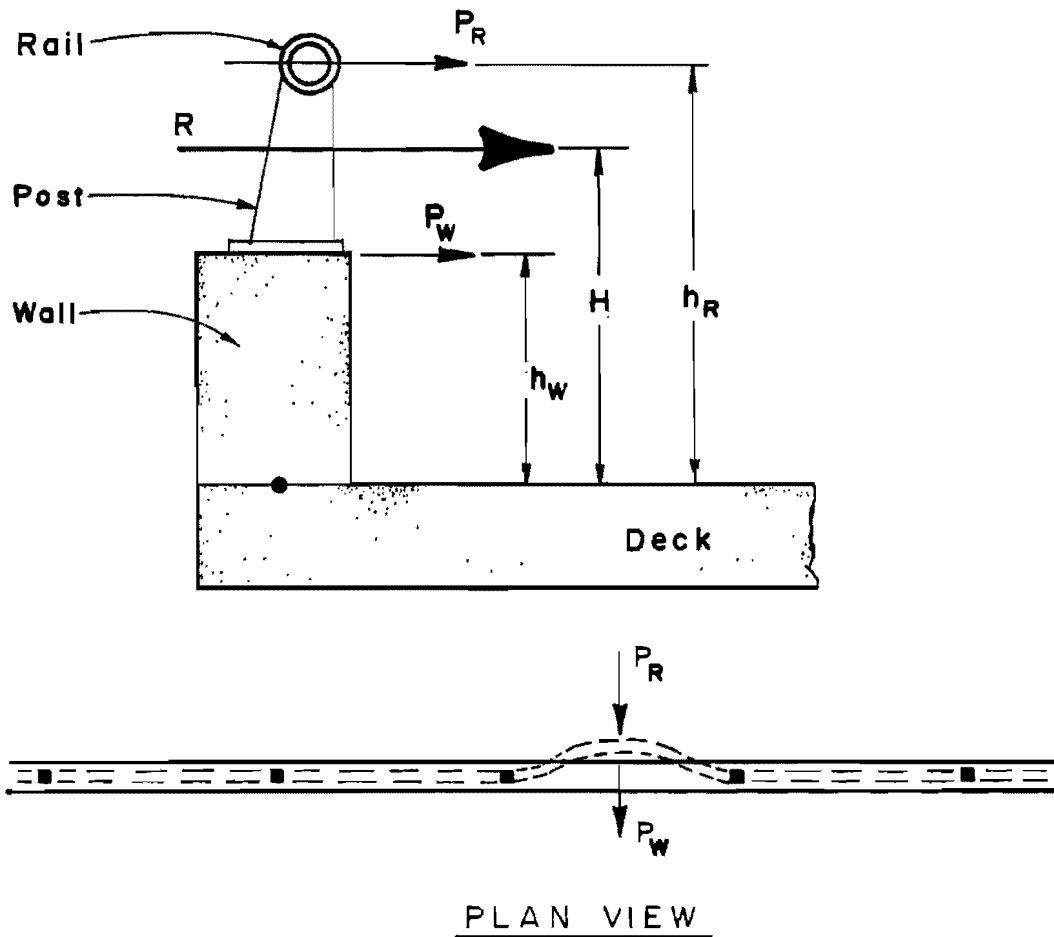

Max. Resultant $R = P_R + P_W$

Effective height $H = \frac{P_R h_R + P_W h_W}{R}$

P_R = ultimate capacity of rail over one span

P_W = ultimate capacity of wall (Appendix "B")

h_W = height of wall

h_R = height of rail

Another possibility is — Max. Effective Height $H = h_R$

Min. Resultant $R = P_R$

FIGURE 15. COMBINATION CONCRETE WALL AND METAL RAIL EVALUATION-IMPACT AT MID-SPAN OF RAIL

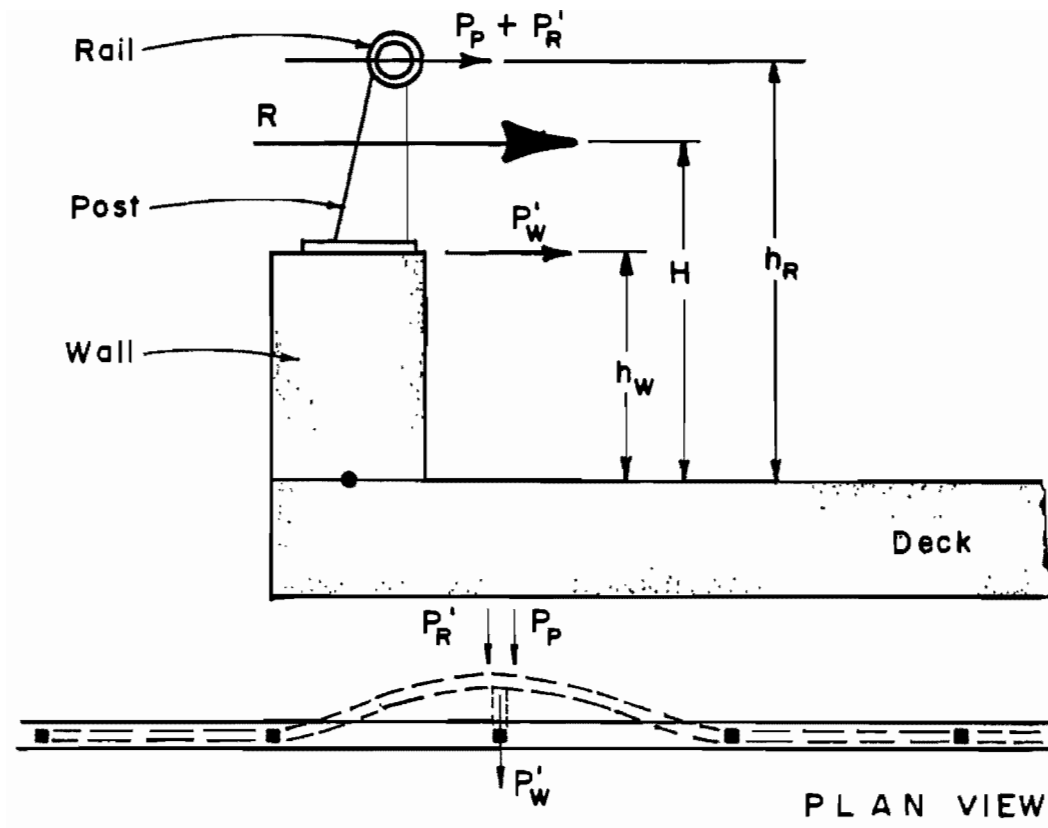

Max. Result, $R = P_p + P'_R + P'_W$

Effective Height $H = \frac{P_p h_R + P'_R h_R + P'_W h_W}{R}$

P_p = ultimate capacity of post = $\sigma_{ult.} \times Z$

P'_R = ultimate capacity of rail over two spans

P'_W = ultimate capacity of wall (Appendix "B")

P'_W = reduced capacity of wall = $\frac{P_w h_w - P_p h_R}{h_w}$
 since post load must be resisted by wall too.

Min. Resultant $R = P_p + P'_R$

Max. Effective Height $H = h_R$

FIGURE 16. COMBINATION CONCRETE WALL AND METAL RAIL EVALUATION-IMPACT AT POST.

the rail strength (P'_R) and the reduced wall strength (P'_W). The effective height of this resultant is as shown in Figure 16. It should also be recognized that a maximum effective height (H) equal to the centroid rail height (h_R) could be obtained but at a reduced resultant strength (R) equal to the post capacity (P_p) and rail capacity (P'_R) only.

Once again the analysis presented here does not consider impacts near open joints in the concrete wall or parapet. The metal rail will help distribute load across such joints. It is recommended that expansion and contraction joints be minimized and that reinforcing steel be continuous across such joints.

STRENGTH EVALUATION OF TEXAS BRIDGE RAILS

In this section one metal rail, the Texas T101 steel rail, three concrete parapet rails (Texas T201, T202, and T5), and two combination concrete parapet and metal rails (Texas T4 steel and C4 steel) were evaluated. The steel rails were selected over the aluminum rails because they have more toughness and reserve strength. Since concrete bridge decks in Texas vary in thickness from 6.75 in. (17.1 cm) to 8.75 in. (22.2 cm) and in amount of reinforcement, the deck will not be considered at this time to limit the capacity of the bridge rail. The assumption is that the bridge deck can be reinforced if necessary to develop the strength of the rail.

METAL RAIL - T101 STEEL

Figure 17 shows the significant structural details of the T101 steel rail. The 4 in. x 3 in. (10 cm x 7.6 cm) tube member can actually vary in wall thickness from 3/16 in. to 1/4 in. to 5/16 in. (.48 cm to .64 cm to .79 cm), permitting the use of different yield strength steels. The 3/16 in. (.48 cm) wall thickness with a yield strength of 50 ksi (345 MPa) was used here because this design has been crash tested with school and intercity buses.

The effective height (H) of the T101 from Figure 17 appears to be 21 in. (53 cm). Appendix "C" presents the detailed analysis of this rail. The ultimate load that each post could resist (P_p) was controlled by the anchor bolts and was found to be 38 kips (169 kN) each. The critical failure load was computed on the basis of the failure mode shown by Figure 12(c), the three-span, two-post mode. This failure mode was

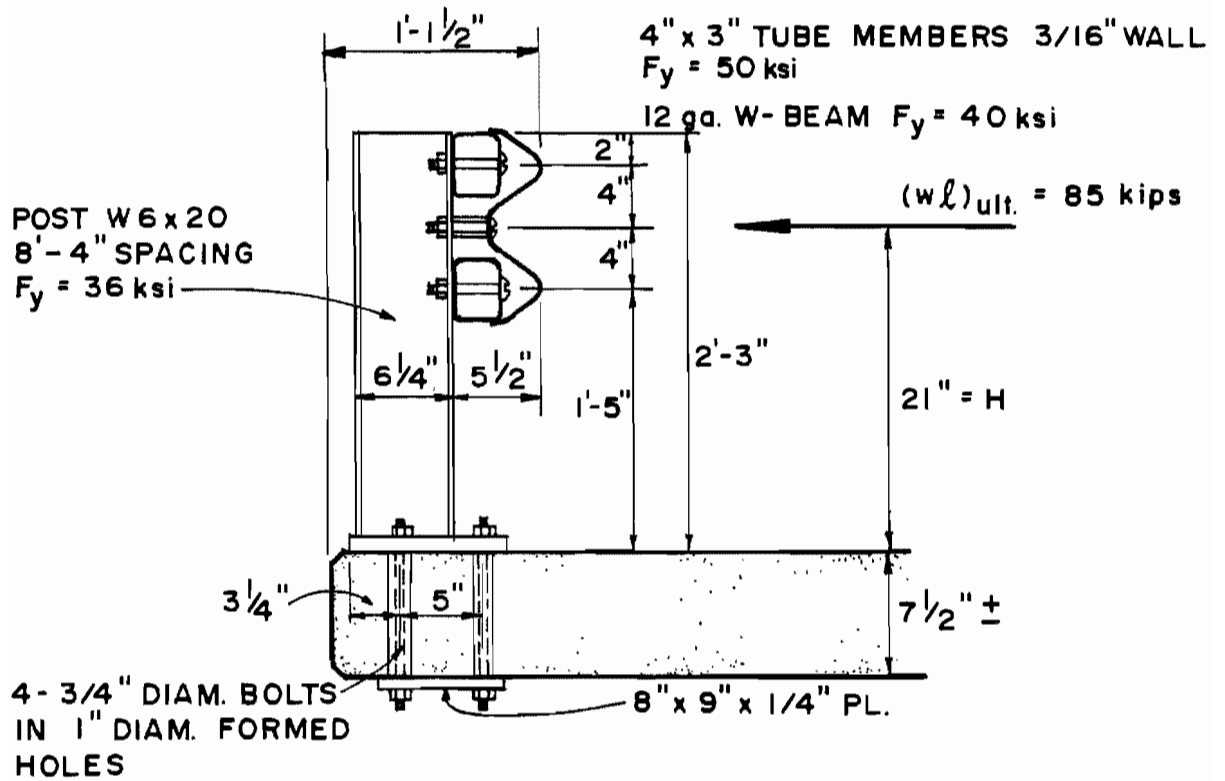

FIGURE 17. TEXAS TIOI STEEL BRIDGE RAIL.

observed in vehicle and bus crash tests conducted by Buth (10). The beam or rail in this failure mode will resist a load (P_R'') of 9 kips (40 kN). Therefore, the total load capacity of this T101 system is estimated to be equal to

$$\begin{aligned}(w\ell)_{ult} &= P_R'' + 2P_p \\ &= 9 \text{ kips} + 2 \times 38 \text{ kips} \\ &= 85 \text{ kips (378 kN)}\end{aligned}$$

with an effective height at this load capacity of

$$H = 21 \text{ in. (53 cm)}$$

Since the load capacity evaluation was controlled by bending moment capacity (of the anchor bolts, in this case), it would appear that the actual load capacity of most rails would be a function of the height of application of the load. Therefore the limiting moment capacity of the T101 is

$$\begin{aligned}M_L &= (w\ell) \times H \\ M_L &= 85 \text{ kips} \times 21 \text{ in.} \\ M_L &= 1785 \text{ kip-in. (201.7 kN}\cdot\text{m)}\end{aligned}$$

If the load was applied at different heights, a new load capacity could be determined so as not to exceed the limiting moment of 1785 kip-in. (201.7 kN·m)

When the post is resisting its ultimate load of 38 kips (169 kN), the moment being applied to the concrete deck slab is about 66.7 kip-ft (90.4 kN·m). Present bridge slabs in Texas are only capable of resisting

an ultimate moment of about 53 kip-ft (72 k·m) and would probably have to be reinforced to develop the total rail capacity of 85 kips (378 kN) or the post moment capacity computed here.

CONCRETE PARAPET RAIL-T201

Figure 18 shows the significant structural details of the type T201 concrete parapet bridge rail. This parapet consists essentially of a 7 in. (17.8 cm) thick concrete wall 27 in. (68.6 cm) high. The load capacity of the parapet was evaluated by the "yield line analysis" shown on Figure 13. The load capacity ($w\ell$) was found to be 48 kips (214 kN) applied at the top of the wall with an effective height $H = 27$ in. (68.6 cm).

Since this load was controlled by bending, the load capacity for lower effective heights of application can be estimated. These loads can be computed so as not to exceed the limiting moment of 48 kips (214 kN) times the 27 in. (68.6 cm) height.

When resisting these loads the concrete parapet wall will place an ultimate bending moment of 9.5 kip-ft (12.8 kN·m) to each foot of bridge deck. Current bridge decks in Texas can resist a bending moment of about 10.2 kip-ft (13.8 kN·m) per foot of the bridge deck so they are adequate.

Reinforcement in the bridge rail as well as the deck could be increased in order to increase the load capacity further. Detailed calculations are presented in Appendix "C".

This analysis did not consider impacts near an open joint which are currently required for the T201 at least every 33 ft (10 m). The strength of this rail at a joint would be about one half the value computed here. The use of such joints should be minimized and reinforcement should be provided to distribute loads across them.

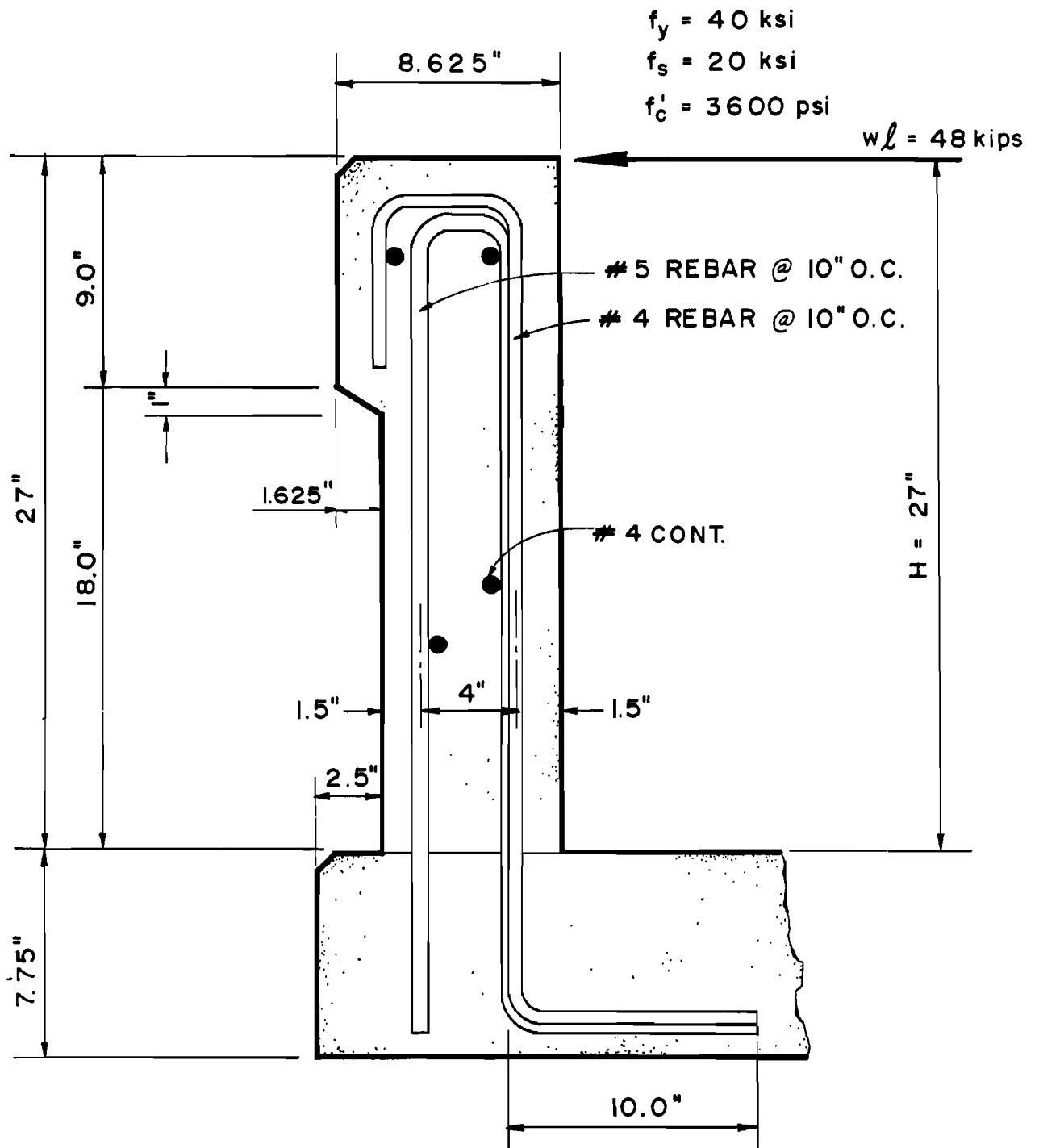

FIGURE 18. TRAFFIC RAIL BARRIER TYPE T201.

CONCRETE PARAPET RAIL - T5

Figure 19 shows the significant structural details of the type T5 traffic rail barrier. This bridge barrier consists of a 32 in. (81 cm) high concrete wall with the New Jersey type safety shape as used on concrete median barriers. The load capacity of the parapet was evaluated by the "yield line analysis" shown by Figure 13. Detailed calculations are presented in Appendix "C".

The load capacity ($w\lambda$) was found to be 59 kips (262 kN) applied at the top of the wall $H = 32$ in. (81 cm). Since this load was also controlled by bending, the load capacity for lower effective heights of application can be estimated. The loads can be computed so as not to exceed the limiting moment of 59 kips (262 kN) times the 32 in. (81 cm) height.

When resisting these loads the concrete parapet wall will place an ultimate bending moment of 12.2 kip-ft (16.5 kN·m) to each foot of bridge deck. Current bridge decks in Texas can resist an ultimate moment of about 10.2 kip-ft (13.8 kN·m) per foot of deck which is close to that needed. Once again this analysis did not consider impact near an open joint which is presently required at least every 33 ft (10 m).

CONCRETE PARAPET RAIL - T202

Figure 20 shows the significant structural details of the type T202 bridge rail or barrier. This bridge consists of a 10 in. (25.4 cm) wide by 14 in. (35.6 cm) deep reinforced concrete beam 27 in. (68 cm) high supported by concrete posts or 5 ft (1.5 m) long sections of concrete wall as shown. The load capacity of this concrete parapet type rail was evaluated by the "yield line analysis" shown by Figure 14 and the three-span

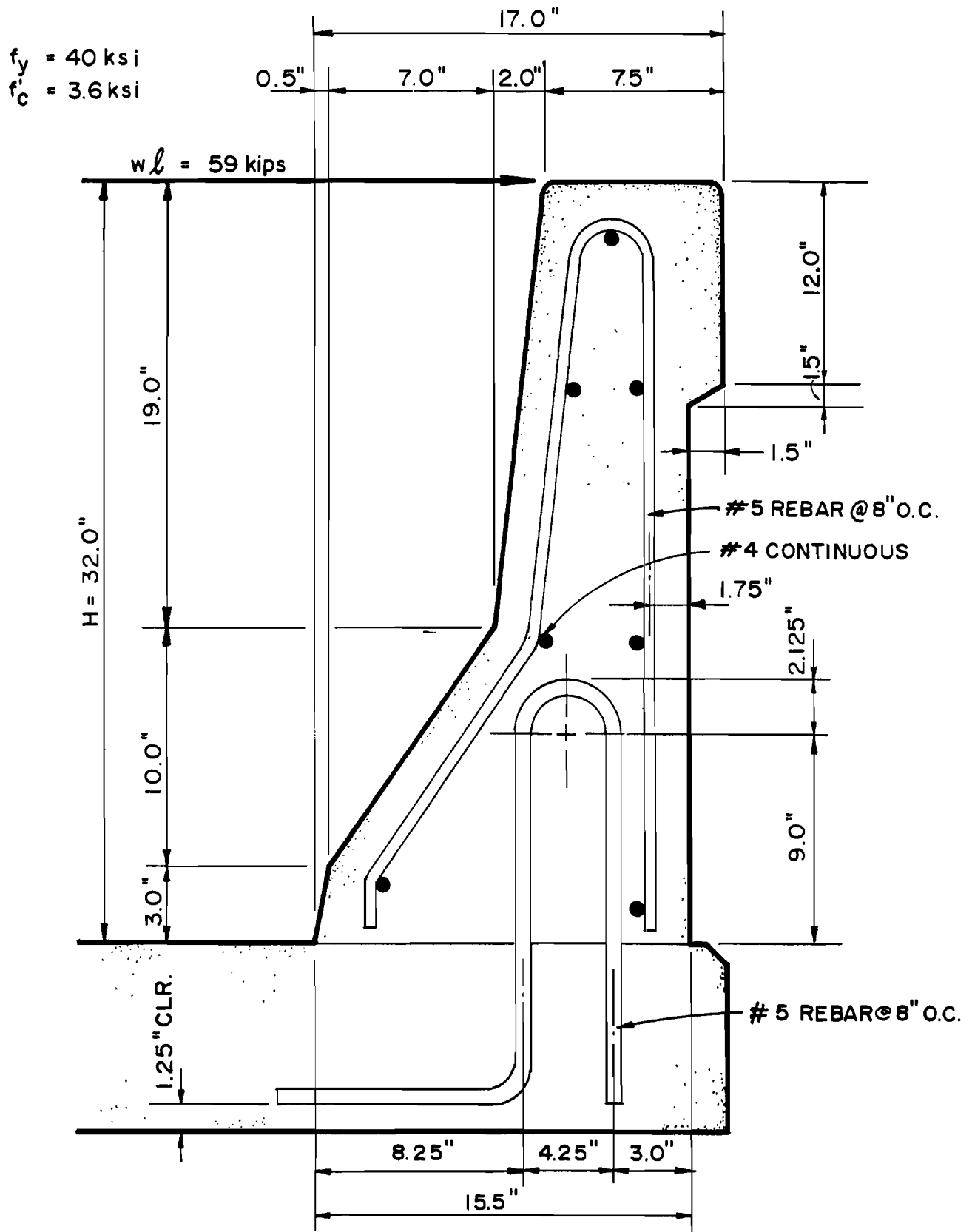

FIGURE 19. TRAFFIC RAIL BARRIER TYPE T5.

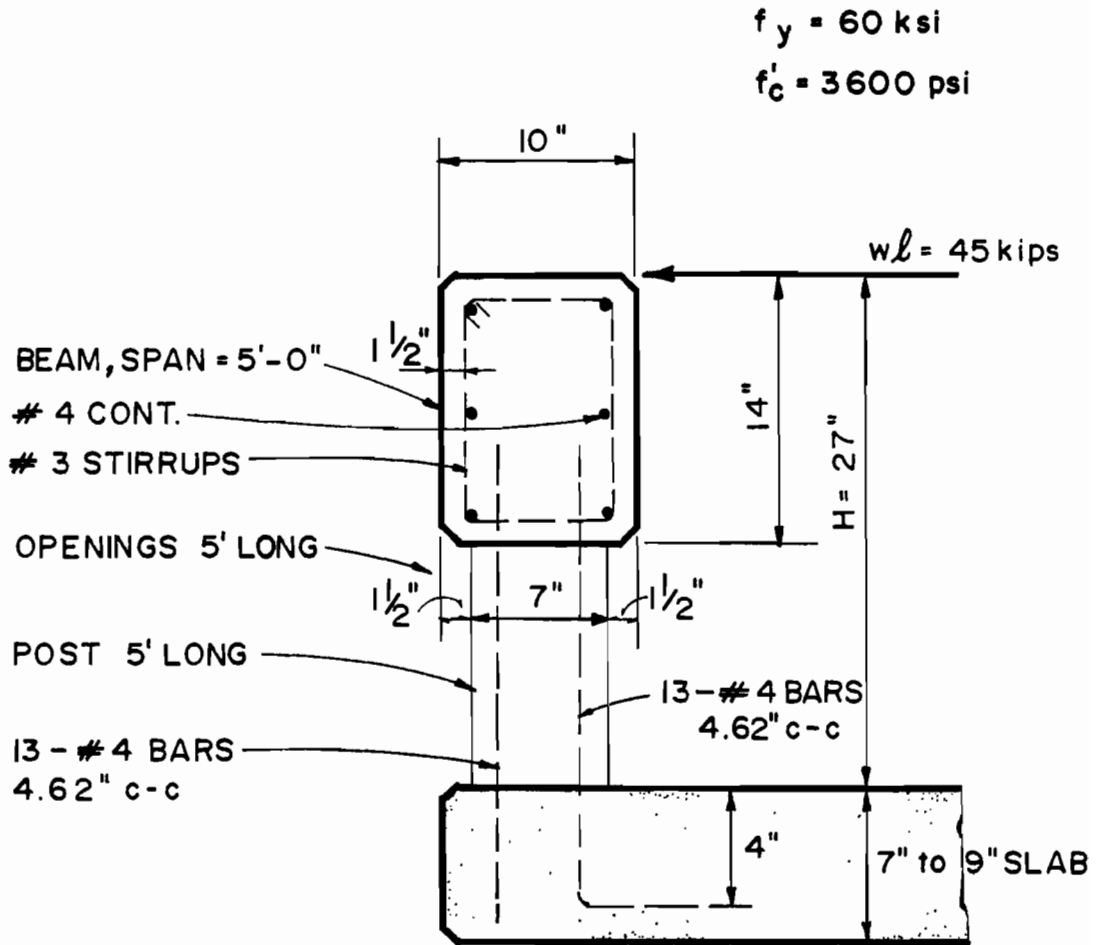

FIGURE 20. TRAFFIC RAIL TYPE T202.

failure mode in Figure 12. Detailed calculations are presented in Appendix "C". Results from the three-span failure mode are believed to be applicable.

The ultimate load capacity ($w\ell$) was found to be 57 kips (253 kN) applied at the top of the wall 27 in. (68 cm) high. Since the load was controlled by bending, the load capacity for lower effective height of application can be estimated by not exceeding the limiting moment of 57 kips (253 kN) times 27 in. (68 cm).

When resisting these ultimate loads, the concrete posts or wall sections will impose a bending moment of 11.86 kip-ft (16.1 kN·m) to each foot of bridge deck. Once again this analysis did not consider impact at an open joint. This concrete rail uses joints only at deck expansion joints. These joints are spaced much farther apart than those of the T201, T5, etc.

COMBINATION CONCRETE PARAPET AND METAL RAIL - T4 STEEL

Figure 21 shows the significant structural details of type T4 combination rail. This rail consists of a 4.875 in. (12.4 cm) by 8 in. (20.3 cm) elliptical steel tube mounted on 11.125 in. (28.3 cm) high steel posts which sit on top of an 18 in. (45.6 cm) high concrete parapet. The ultimate load capacity of the metal rail and posts were determined by the methods previously discussed except that the yield strength of the steel was used instead of its ultimate strength. The ultimate strength of the anchor bolts was used rather than yield strength. The load capacity of the concrete wall was evaluated by the "yield line analysis" shown by Figure 13. The resultant ultimate load capacity of this system of structural elements was determined by the procedure shown on Figure 16. The critical impact point was found to be at a post location.

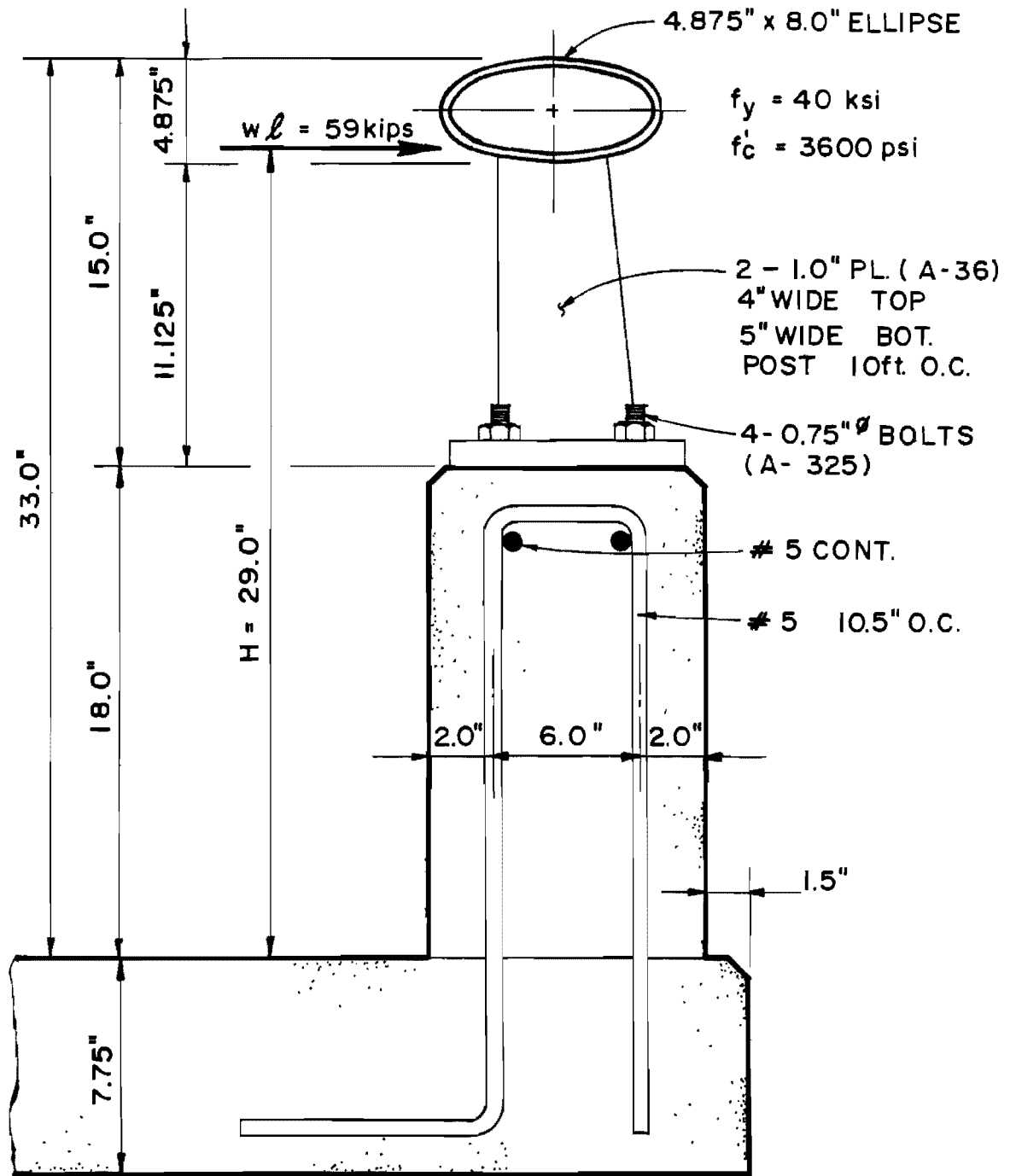

FIGURE 21. TRAFFIC RAIL BARRIER TYPE T4.

The post capacity (P_p) was controlled by the ultimate strength of the anchor bolts and was found to be 38 kips (169 kN). The rail capacity over two spans (P'_R) was found to be 13 kips (58 kN). The reduced wall capacity (P'_W) remaining after supporting the post was 8 kips (36 kN). The sum of these yielded a net resultant capacity of 59 kips (263 kN) located at an effective height (H) of 29 in. (74 cm).

If one wants the maximum possible effective height $H = 30.5$ in. (77.5 cm), the resultant capacity would simply be the sum of the post (P_p) and rail (P'_R) capacities or 51 kips (227 kN).

To obtain a larger rail capacity one could take the maximum wall capacity (P_W) of 72 kips (320 kN) located at the top of the wall 18 in. (46 cm) and the rail capacity over two spans (P'_R) of 13 kips (58 kN) located at 30.5 in. (77.5 cm). This would yield a resultant load of 85 kips (378 kN) located at an effective height of 20 in. (51 cm). Details of the analysis are presented in Appendix "C".

Once again when this rail is resisting these ultimate loads, the concrete parapet wall is placing an ultimate bending moment of 9.82 kip-ft (13.3 kN·m) on each foot of bridge deck. Present bridge decks in Texas can resist an ultimate bending moment of 10.2 kip-ft (13.8 kN·m) per foot of deck and thus are adequate.

COMBINATION CONCRETE PARAPET AND METAL RAIL - C4 STEEL

Figure 22 shows the significant structural details of the type C4 combination rail. This rail is similar to the type T4 except the elliptical tube is mounted on 13.125 in. (33.3 cm) high steel posts which sit on top of a 21 in. (53 cm) high concrete parapet. The ultimate load capacity of this system of structural elements was determined by the procedures used for the

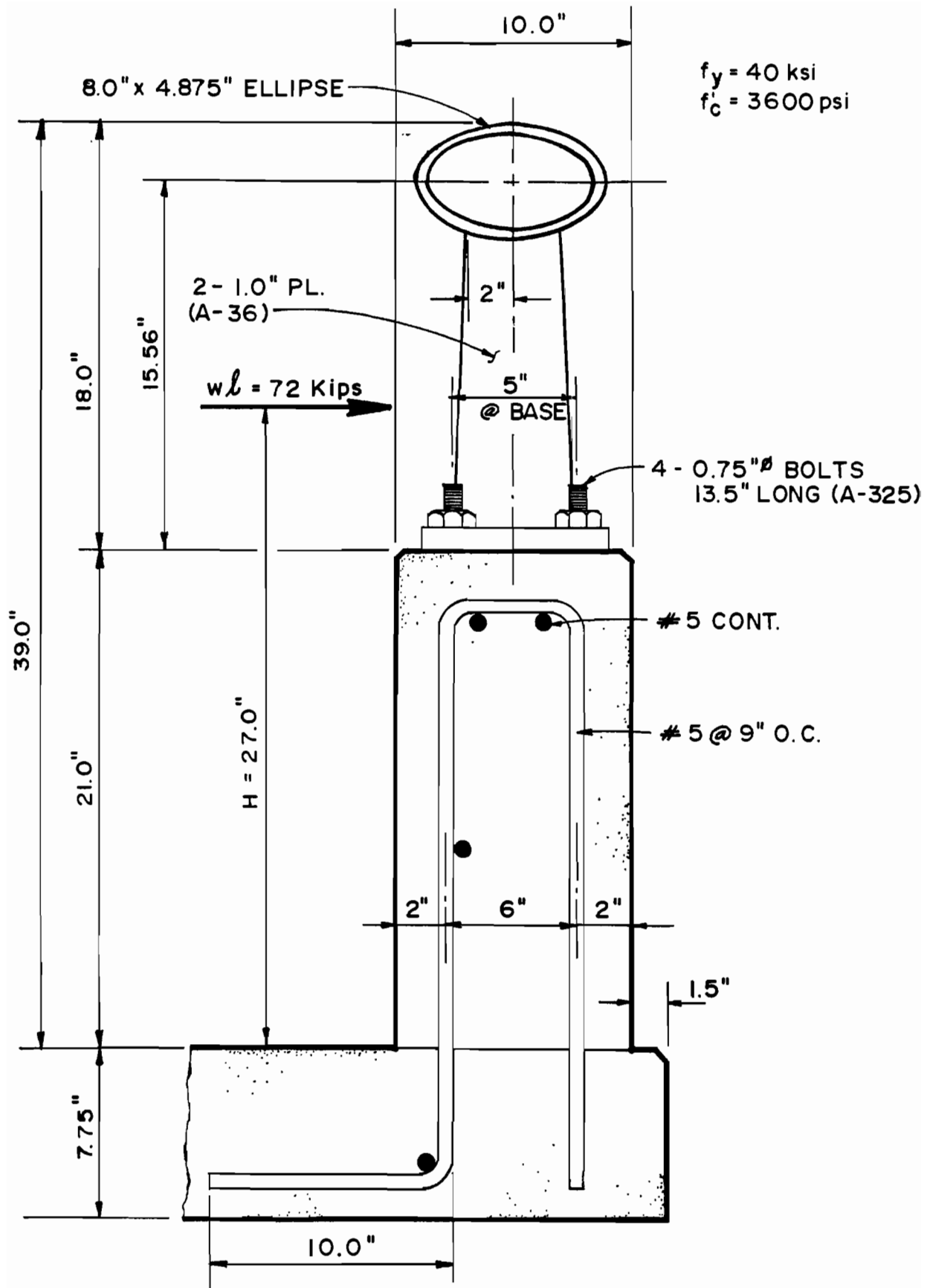

FIGURE 22. TRAFFIC RAIL BARRIER TYPE C4.

type T4 previously described. The detailed calculations are presented in Appendix "C".

The post capacity (P_p) was controlled by its plastic bending moment and was found to be 29 kips (192 kN). The rail capacity (P'_R) was the same as the T4 and was 13 kips (58 kN). The reduced wall capacity (P'_W) remaining after supporting the post was about 30 kips (133 kN). The sum of these yielded a net resultant capacity of 72 kips (320 kN) located an effective height (H) of 27 in. (69 cm).

If one wants the maximum possible effective height $H = 36.6$ in. (93 cm) the resultant capacity would simply be the sum of the post (P_p) and rail (P'_R) capacities or 42 kips (187 kN).

To obtain a larger rail capacity one could take the maximum wall capacity (P'_W) of 80 kips (356 kN) located at the top of the wall 21 in. (53 cm) and the rail capacity over two spans (P'_R) of 13 kips (58 kN) located at 36.6 in. (93 cm) above the deck. This would yield a resultant load of 93 kips (414 kN) located at an effective height of 23 in. (58 cm).

When this rail is resisting these ultimate loads, the concrete parapet is placing an ultimate bending moment of 11.3 kip-ft (15.3 kN·m) on each foot of the bridge deck.

DISCUSSION OF RESULTS

From the previous strength evaluation of Texas bridge rails, it was found that the load capacity of the rail depended on the height of application of the load. In order to better compare these rails, the previous results have been plotted on Figure 23 which summarized and compares the strength and effective height of these bridge rails. The results on this figure assume that the bridge deck will develop the cantilever moment capacity of the concrete parapets or posts in the case of the T101. The results on Figure 23 also assume impact is not near an open joint

From Figure 23 it appears that the C4 combination rail is the strongest and highest. The T5 concrete parapet is close behind the C4 in strength and height. The metal rail T101 is very close to the C4 and T5 in strength but it has a limited maximum effective height of only about 25 in. (64 cm), the distance to the top corrugation of the W-beam. The combination rail T4 is also close to the top three rails. The two concrete parapet rails, the T202 and T201, appear to lag behind the other four rails in strength and height in this comparison.

For this strength evaluation, present analysis and design theory have been extended to extreme limits. For example, the ultimate strength 69 ksi (476 MN/m^2) was used to compute the ultimate capacity of the A36 wide flange post in the T101 rail. This was done because the flange and web of the wide flange are welded to a base plate at the point where these high stresses occur and therefore cannot buckle. All such assumptions have been made with care and in most cases they are supported by test data. Full scale crash test results on such rails have shown that they have considerable reserve strength beyond what an elastic stress analysis would indicate.

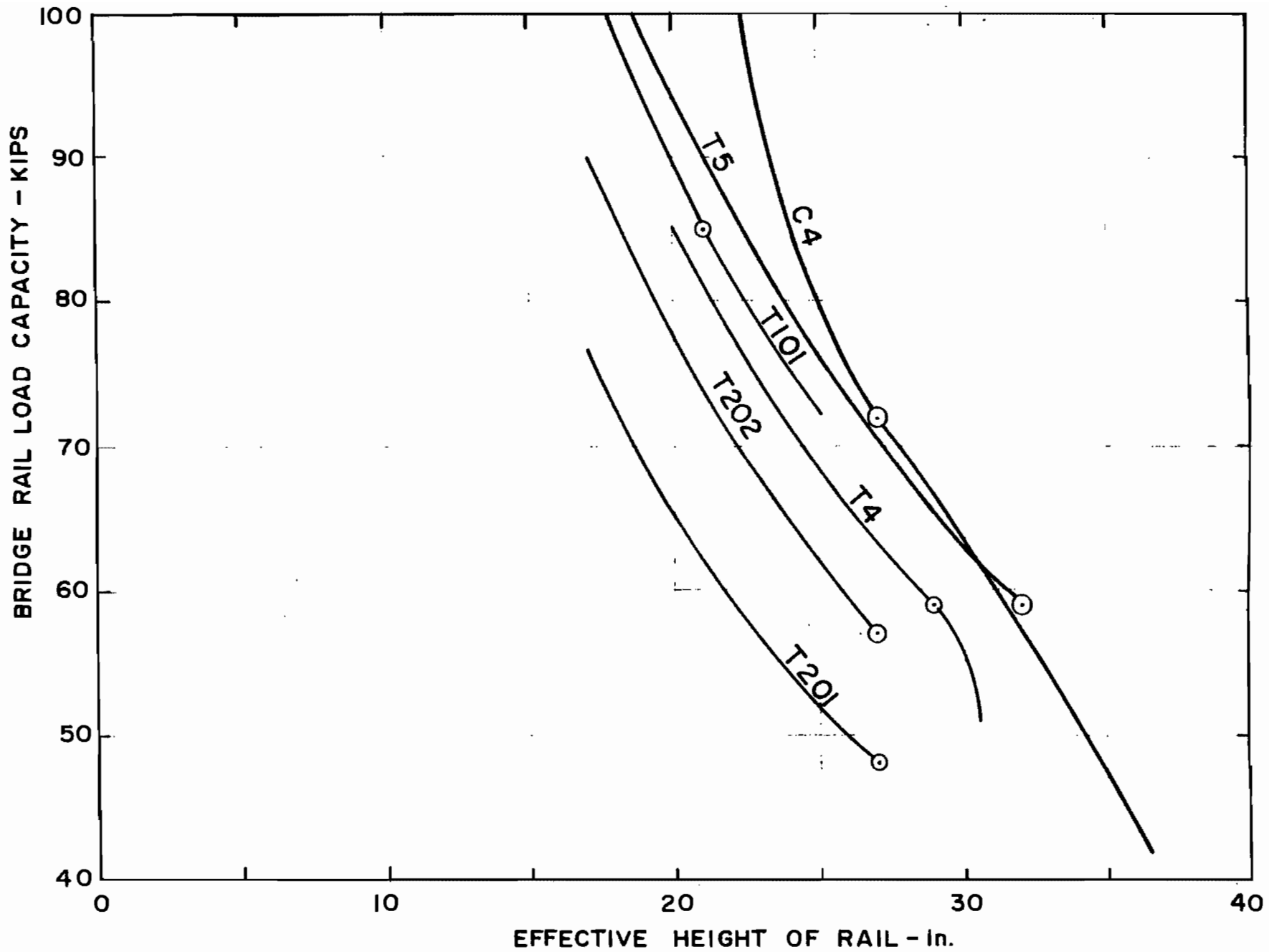

FIGURE 23. SUMMARY OF STRENGTH AND EFFECTIVE HEIGHT EVALUATION OF TEXAS BRIDGE RAILS.

SUMMARY

Figure 6 presents the summary of the impact forces which various type vehicles place on a rigid traffic rail when they impact it at 60 mph (96.6 km/hr) and 15 degrees. Figure 8 presents a summary of the apparent barrier effective heights required to prevent such vehicles from rolling over rigid traffic rails. When these data are compared to the strength and effective height of the six Texas bridge rails presented in Figure 23, one can determine how effective these six bridge rails might be.

PASSENGER CAR

For example, a 4500 lb (2041 kg) vehicle impacting a rigid rail at 60 mph (97 kph) and 25 degrees will generate an impact force of about 50 kips (222 kN) (Figure 6) and require an effective height of 16 to 20 in. (41 to 51 cm) (Figure 8) to prevent rollover. From Figure 23 it appears that all six of these rails will easily meet these requirements. For some confirmation of this conclusion the T101 has been successfully crash tested under these conditions.

SCHOOL BUS

From Figure 6 it can be seen that a typical school bus of 20,000 lb (9702 kg) impacting a rigid traffic rail at 60 mph (97 kph) and 15 degrees will generate an impact force of from 55 to 85 kips (245 to 378 kN). From Figure 8 the school bus will require an effective height of from 22 to 32 in. (56 to 81 cm) to prevent rollover. When these forces and heights are compared to Figure 23 it can be seen that all of the rails meet the minimum requirements of 55 kips (245 kN) and 22 in. (56 cm) but none meet

the maximum requirements of 85 kips (378 kN) and 32 in. (81 cm). If the average impact force and height of 70 kips (311 kN) and 27 in. (69 cm) are used, the C4 and T5 bridge rails appear adequate and the T101 and T4 rails are very close. For some confirmation of these conclusions, the T101 bridge rail has been successfully crash tested by two school buses under these conditions by Buth (10). The two crash tests cited are not positive confirmation of the height requirements because in both tests the front axle was knocked from under the bus, quickly lowering its center of gravity about 9 or 10 in. (23 to 25 cm). The two tests do positively confirm the strength capability of the T101 to redirect a school bus.

INTERCITY BUS

The next comparison will be for a 30,000 to 40,000 lb (13,608 to 18,144 kg) intercity bus impacting at 60 mph (97 kph) and 15 degrees. From Figure 6 the rigid rail impact force will be from 75 to 150 kips (334 to 667 kN) and from Figure 8 the required height will be from 19 to 31 in. (48 to 79 cm). From Figure 23 it can be seen that the C4, T5, T101 and T4 would meet the minimum requirements but none would meet even the average requirements of about 112 kips (498 kN) and 25 in. (64 cm). It is interesting to note that the T101 rail has been crash tested by an intercity bus under these impact conditions. The strength of the T101 was just barely able to redirect the bus, and the bus did roll over on the bridge. The rail deflected laterally 3 ft (.9 m) or more and was certainly not rigid. In the author's opinion the capacity of the T101 was exceeded in the test.

TRACTOR-TRAILER

The last comparison will be for an HS20-44 tractor-trailer type vehicle weighing from 60,000 to 72,000 lb (27,000 to 32,660 kg) impacting at 60 mph (97 kph) and 15 degrees. From Figure 6 the impact force would be from 125 to 250 kips (556 kN to 1112 kN) and from Figure 8 the effective rail height would have to be from 42 to 57 in. (107 to 145 cm). It appears from this analysis that none of the existing Texas bridge rails can redirect such heavy vehicles under these severe impact conditions.

CONCLUSIONS

From this analysis it appears that the following conclusions can be drawn:

1. All six rails (T101, T201, T202, T5, T4, and C4) can restrain and redirect 4,500 lb (2,041 kg) passenger cars at 60 mph (97 kph) and 25-degree angle.
2. The combination metal rail and concrete parapet C4 and concrete parapet T5 bridge rails should restrain and redirect a school bus at 60 mph (97 kph) and 15 degrees. The weaker and lower combination T4 rail and the T101 metal rail are also probably capable of restraining and redirecting a school bus.
3. The combination C4 and concrete parapet T5 bridge rails have a chance of redirecting a large intercity bus at 60 mph (97 kph) and 15 degrees.
4. None of the six rails evaluated appear to have a chance of redirecting a loaded, high center-of-gravity, HS20-44 tractor-trailer at 60 mph (97 kph) and 15 degrees.

All of these conclusions should be confirmed by full-scale crash tests since they are based on relatively simple theory applied to a very complex problem. This analytical exercise has served to emphasize the complexity of the problem.

REFERENCES

1. "Houston Accident Brings on Extensive Investigation," MODERN BULK TRANSPORTER, Vol. 40, No. 2, Washington, D.C., August 1977, pp. 14-17.
2. "Student Transportation Lines, Inc., Charter Bus Climbing of Bridge Rail and Overturn - Near Martinez, California," NTSB Highway Accident Report No. NTSB-HAR-77-2, Washington, D.C., May 21, 1976.
3. "Recommended Procedures for Vehicle Crash Testing of Highway Appurtenances," TRB Circular No. 191, Washington, D.C., February 1978.
4. Standard Specifications for Highway Bridges, Twelfth Edition, American Association of State Highway and Transportation Officials, Washington, D.C., 1977.
5. Wiles, E. O., Bronstad, M. E., and Kimball, C. E., "Heavy Vehicle Crash Test Evaluation of Concrete Safety Shape," presented at the Annual Meeting of the Highway Research Board, Washington, D.C., January 1977.
6. Hirsch, T. J. and Post, E. R., "Truck Tests on Texas Concrete Median Barrier," Research Report 146-7, Texas Transportation Institute, Texas A&M University, December 1972.
7. "Tentative Service Requirements for Bridge Rail Systems," NCHRP Report 86, Washington, D.C., 1970.
8. Kimball, C. E., Bronstad, M. E., et al., "Development of a New Collapsing Ring Bridge Rail System," Report No. FHWA-RD-75-510, Federal Highway Administration, January 1975.
9. Bloom, J. A., Rudd, T. J., and Labra, J. J., "Establishment of Interim Guidelines for Bridge Rails Required to Contain Heavy Vehicles," Report No. FHWA-RD-75-45, Vols. I, II and III, Federal Highway Administration, Washington, D.C., November 1974.
10. Buth, C. E., unpublished vehicle crash test data from DOT-FHWA-11-9181 being conducted at the Texas Transportation Institute, College Station, Texas, Oct. 1978.
11. Hirsch, T. J., Panak, J. J., and Buth, C. E., "Tubular W-Beam Bridge Rail," Research Report 230-1, Texas Transportation Institute, Texas A&M University, October 1978.

APPENDIX "A"

COMPUTATION OF LATERAL IMPACT FORCES

(from Equations 1, 2, 3 and 4)

TRAFFIC RAIL IMPACT FORCE - RIGID RAIL

HEAVY PASSENGER CAR, 4500 lb

$$L = 17.5 \text{ ft} \quad 2B = 6.5 \text{ ft} \quad A = .454$$

60 mph - 25°

$$G_{lat \text{ avg}} = \frac{(88 \text{ ft/sec})^2 \sin^2 25^\circ}{2 \times 32.2 \text{ ft/sec}^2 [7.95 \text{ ft} \sin 25^\circ - 3.25 \text{ ft}(1 - \cos 25^\circ)]}$$

$$= \frac{7744 \times .1786}{64.4 [7.95 \times .423 - .304]}$$

$$G_{lat \text{ avg}} = 7.03 \text{ g's}$$

$$F_{lat \text{ avg}} = 4500 \text{ lb} \times 7.03$$

$$F_{lat \text{ avg}} = 32 \text{ kips}$$

$$F_{lat \text{ max}} = 32 \text{ kips} \times \frac{\pi}{2}$$

$$F_{lat \text{ max}} = 50 \text{ kips}$$

60 mph - 15°

$$G_{lat \text{ avg}} = 4.13 \text{ g's}$$

$$F_{lat \text{ avg}} = 4.13 \times 4500 \text{ lb} = 18.6 \text{ kips}$$

$$F_{lat \text{ avg}} = 18.6 \times \frac{\pi}{2} = 29.2 \text{ kips}$$

RAIL IMPACT FORCE - RIGID RAIL

SCHOOL BUS, 20,000 lb

$$G_{lat} = \frac{\frac{60 \text{ mph} - 15^\circ}{88^2 \sin^2 15^\circ}}{2 \times 32.2 [18.5' \sin 15^\circ - 4'(1 - \cos 15^\circ)]}$$
$$= \frac{7744 \times .067}{64.4 [18.5 \times .259 - .136]}$$

$$G_{lat} = 1.73 \text{ g's}$$

$$F_{lat} = 20,000 \text{ lb} \times 1.73$$

$$F_{lat} = 35 \text{ kips (avg)}$$

$$F_{lat \text{ max}} = 35 \text{ kips} \times \frac{\pi}{2}$$

$$F_{lat \text{ max}} = 55 \text{ kips}$$

TRAFFIC RAIL IMPACT FORCE - RIGID RAIL

LARGE INTERCITY BUS, 40,000 lb

60 mph - 15°

$$\begin{aligned} G_{lat} &= \frac{v^2 \sin^2 \theta}{2g [AL \sin \theta - B(1 - \cos \theta) + D]} \\ &= \frac{(88 \text{ ft/sec})^2 \sin^2 15^\circ}{2 \times 32.2 \text{ ft/sec}^2 [22 \text{ ft} \sin 15^\circ - 4 \text{ ft}(1 - \cos 15^\circ)]} \\ &= \frac{7744 \times .067}{64.4 [22 \times .259 - .136]} \end{aligned}$$

$$G_{lat} = 1.45 \text{ g's (avg)}$$

$$F_{lat} = 40,000 \text{ lb} \times 1.45$$

$$F_{lat} = 58 \text{ kips (avg)}$$

$$F_{lat \text{ max}} = F_{lat \text{ max}} \times \frac{\pi}{2}$$

$$F_{lat \text{ max}} = 91 \text{ kips}$$

TRAFFIC RAIL IMPACT FORCE

72,000 lb AASHTO HS20-44 TRUCK-TRAILER

IF RAIL REDIRECTS TRACTOR, TRAILER WILL FOLLOW

THEREFORE MAX. IMPACT FORCE WILL OCCUR DURING
REDIRECTION OF 40,000 lb TRACTOR

60 mph - 15°

$$G_{lat} = \frac{(88 \text{ ft/sec})^2 \sin^2 15^\circ}{2 \times 32.2 \text{ ft/sec}^2 [14.2 \text{ ft} \sin 15^\circ - 4 \text{ ft}(1 - \cos 15^\circ)]}$$
$$= \frac{7744 \times .067}{64.4 [14.2 \times .259 - .136]}$$

$$G_{lat} = 2.28 \text{ g's (avg)}$$

$$F_{lat \text{ avg}} = 40,000 \text{ lb} \times 2.28 \text{ g's}$$

$$F_{lat \text{ avg}} = 91 \text{ kips}$$

TRACTOR IMPACT

$$F_{lat \text{ max}} = 91 \text{ kips} \times \frac{\pi}{2}$$

40,000 lb
65 in. avg CG
length 20 ft

$$F_{lat \text{ max}} = 143 \text{ kips}$$

TRAILER $G_{lat} = 2.15 \text{ g's}$

Length = 40 ft
CG = 78 in.
WB = 30 ft
Weight = 58 kips

$$F_{lat \text{ avg}} = 2.15 \times 32,000 \text{ lb}$$

$$F_{lat \text{ avg}} = 69 \text{ kips}$$

$$F_{lat \text{ max}} = 108 \text{ kips}$$

APPENDIX "B"
YIELD LINE ANALYSIS OF
CONCRETE PARAPET WALL
AND
OPEN CONCRETE WALL

YIELD LINE ANALYSIS OF CONCRETE PARAPET
WALL AS BRIDGE RAIL - "DISTRIBUTED LOAD"

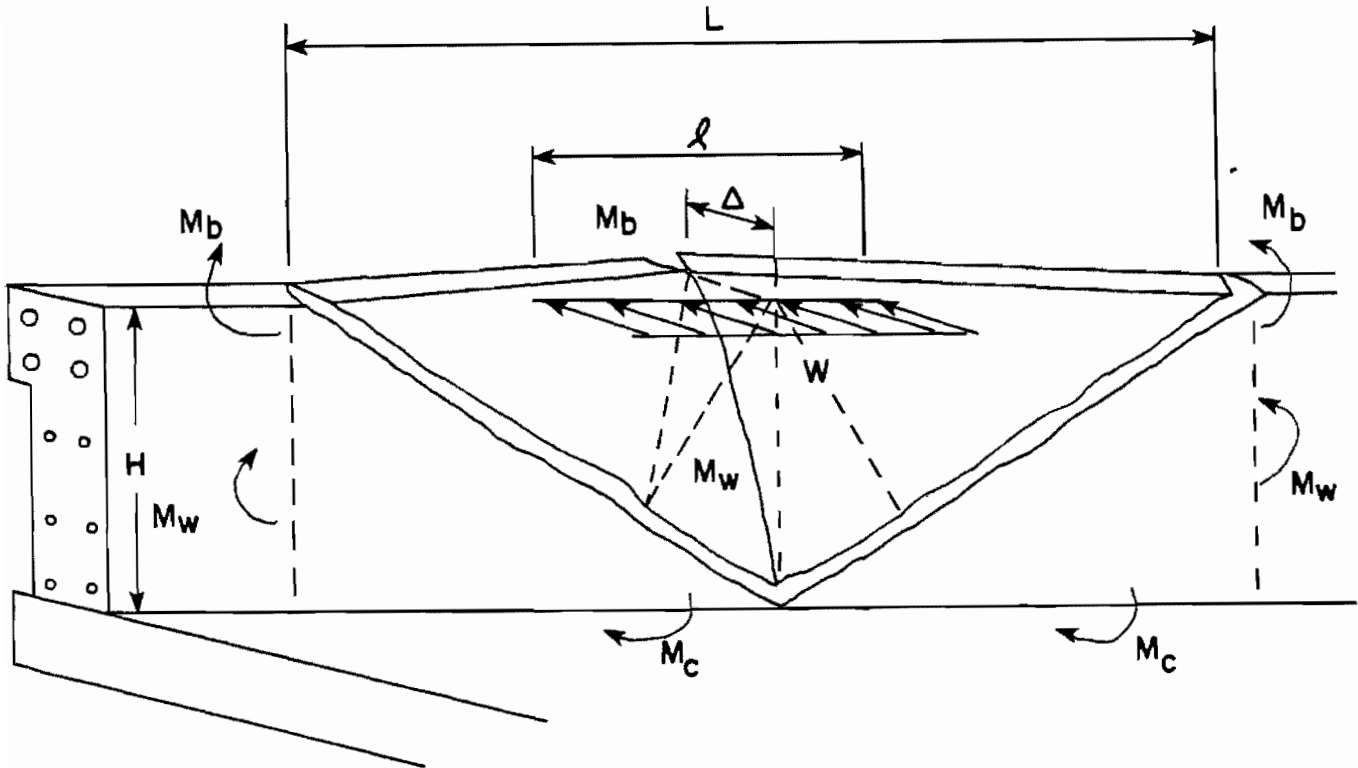

Total Load = wl

External Work = Internal Energy Absorbed

$$wl \Delta \left(\frac{L - l/2}{L} \right) = M_b \times 4 \times \frac{\Delta}{L/2} + M_w H \times 4 \times \frac{\Delta}{L/2} + M_c L \frac{\Delta}{H}$$

$$wl \left(\frac{L - l/2}{L} \right) = \frac{8M_b}{L} + \frac{8M_w H}{L} + \frac{M_c L}{H}$$

$$w\ell = \frac{8M_b}{L - \ell/2} + \frac{8M_w H}{L - \ell/2} + \frac{M_c L^2}{H(L - \ell/2)}$$

What is $L = ?$ Length L that gives min. $(w\ell)$ is critical

$\frac{d(w\ell)}{dL} = 0$ defines L which gives min. $(w\ell)$

$$0 = \frac{d(w\ell)}{dL} = -\frac{8M_b}{(L - \ell/2)^2} - \frac{8M_w H}{(L - \ell/2)^2} + \frac{M_c}{H} \left[\frac{2L}{L - \ell/2} - \frac{L^2}{(L - \ell/2)^2} \right]$$

$$-\frac{8M_b}{(L - \ell/2)^2} - \frac{8M_w H}{(L - \ell/2)^2} + \frac{M_c L}{H(L - \ell/2)} \left[2 - \frac{L}{L - \ell/2} \right] = 0$$

$$L^2 - \ell L - 8H \left(\frac{M_b + M_w H}{M_c} \right) = 0$$

$$L = \frac{\ell}{2} + \sqrt{\left(\frac{\ell}{2}\right)^2 + 8H \left(\frac{M_b + M_w H}{M_c} \right)}$$

If $\ell = 0$ then $(w\ell)_{ult.} = P_{ult.}$ a concentrated load and this solution yield previous one

If $\ell = L$ then $(w\ell)_{ult.}$ is distributed over length of failed wall, then

$$(w\ell)_{ult.} = \frac{16 M_b}{L} + \frac{16 M_w H}{L} + \frac{2 M_c L}{H}$$

$$\text{and } L_{cr} = \sqrt{8H \left(\frac{M_b + M_w H}{M_c} \right)}$$

YIELD LINE ANALYSIS OF OPEN CONCRETE RAIL

10" x 14" Concrete Beam on 7" Wall with 5' long openings at 10' centers

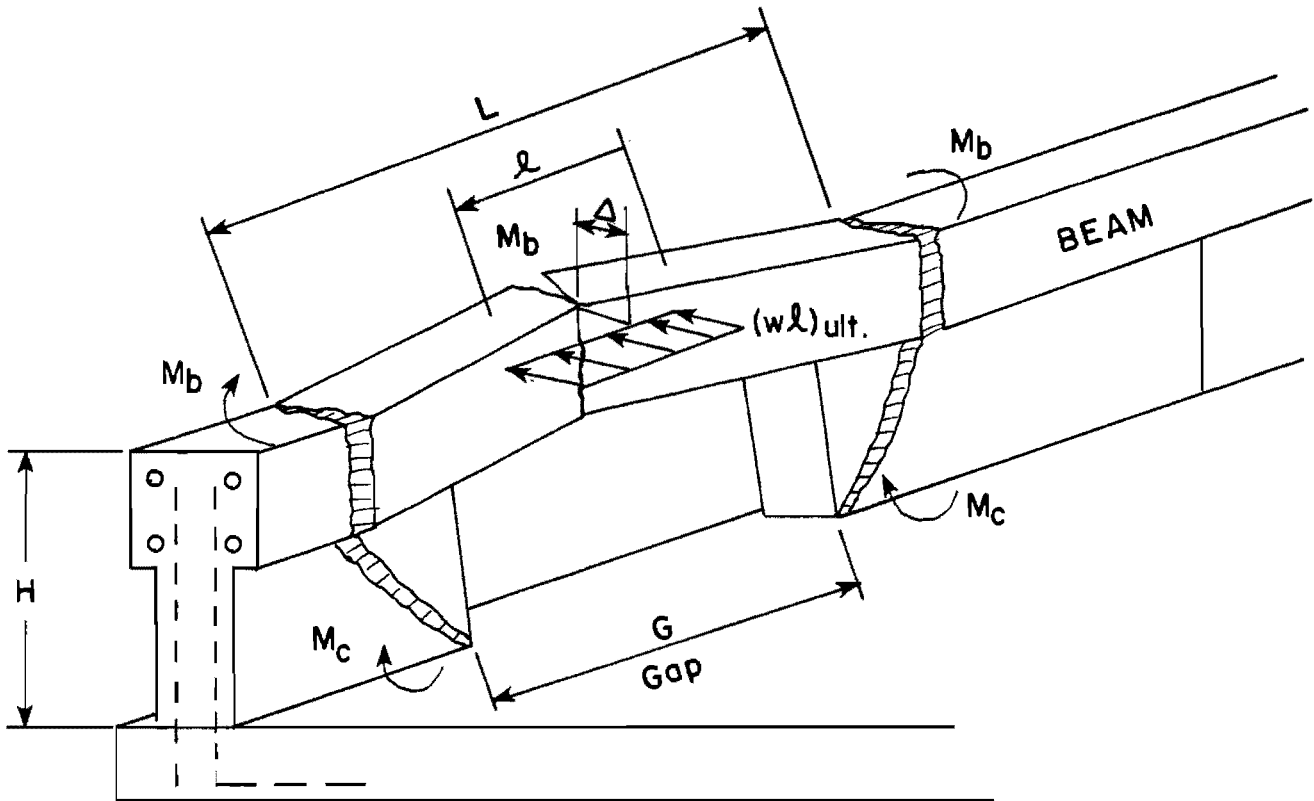

$$(w\ell)_{ult.} \Delta \left(\frac{L - \ell/2}{L} \right) = 4M_b \frac{\Delta}{L/2} + 2M_c \left(\frac{L-G}{2} \right) \frac{\Delta}{H}$$

DISTRIBUTED LOAD $(w\ell)_{ult.}$

$$(w\ell)_{ult.} \left(\frac{L - \ell/2}{L} \right) = \frac{8M_b}{L} + M_c \frac{(L-G)}{H} \frac{L}{L}$$

$$(w\ell)_{ult.} = \frac{8M_b}{\left(L - \ell/2\right)} + \frac{M_c L (L-G)}{H \left(L - \ell/2\right)}$$

What is $L = ?$ L is length that gives min. $(w\ell)_{ult.}$

$$\frac{d(w\ell)}{dL} = 0 \text{ defines } L \text{ that gives min. } (w\ell)_{ult.}$$

$$\frac{d(w\ell)}{dL} = -\frac{8M_b}{\left(L - \ell/2\right)^2} + \frac{M_c}{H} \left[\frac{2L - G}{\left(L - \ell/2\right)} - \frac{L(L - G)}{\left(L - \ell/2\right)^2} \right] = 0$$

$$\frac{8M_b}{\left(L - \ell/2\right)} = \frac{M_c}{H} \left[2L - G - \frac{L(L - G)}{\left(L - \ell/2\right)} \right]$$

$$L^2 - \ell L - \left[\frac{8H}{M_c} M_b - \frac{G\ell}{2} \right] = 0$$

$$L_{cr} = \frac{\ell}{2} + \sqrt{\left(\frac{\ell}{2}\right)^2 + \frac{8HM_b}{M_c} - \frac{G\ell}{2}}$$

ℓ = length of distributed impact force ≈ 3.5 ft

G = gap length of hole in wall ≈ 5 ft

H = height of wall = ft

M_b = beam ult. moment capacity = kip-ft

M_c = wall cantilever moment capacity = $\frac{\text{kip-ft}}{\text{ft. of wall}}$

YIELD LINE ANALYSIS OF CONCRETE PARAPET
WALL AS BRIDGE RAIL - "CONCENTRATED LOAD"

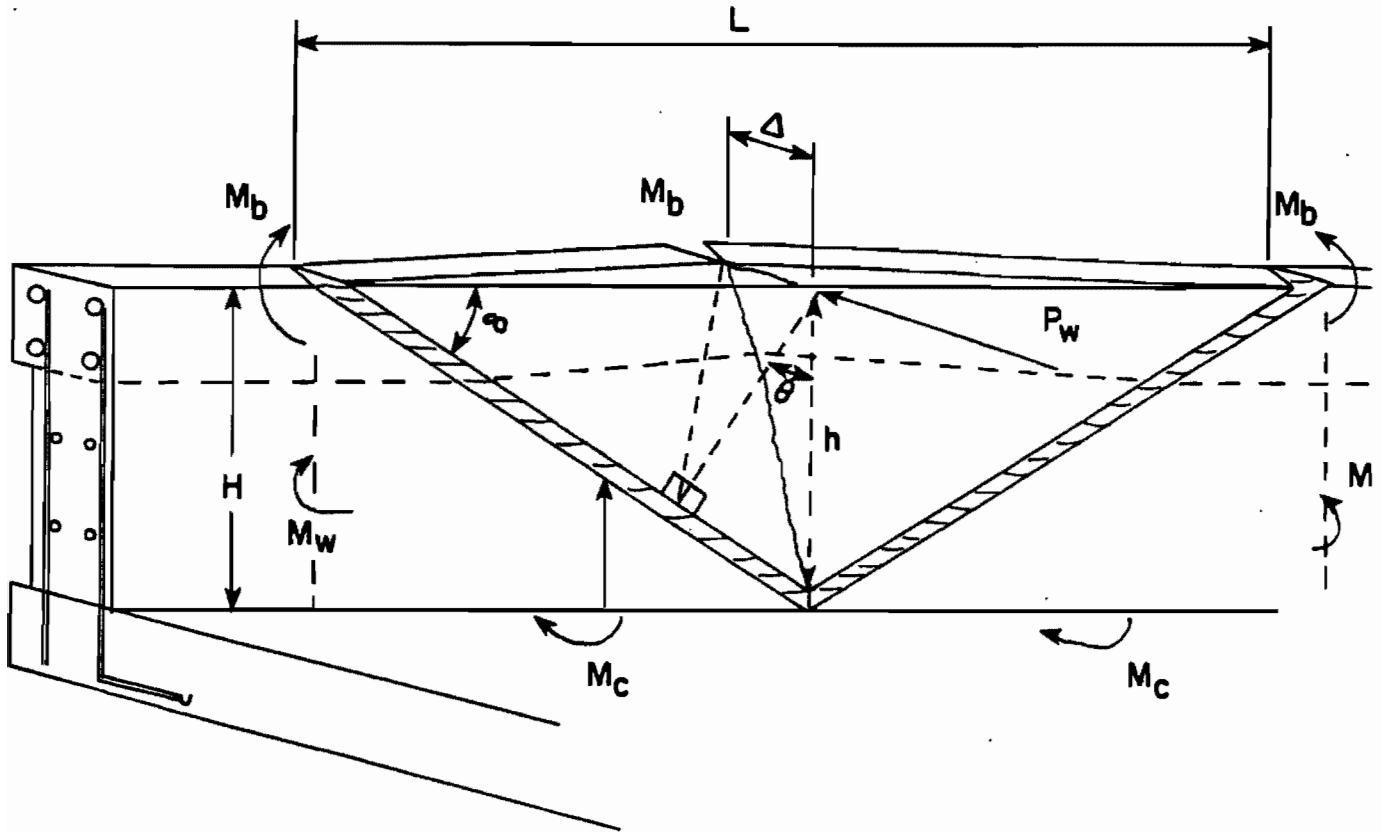

$$P_w \Delta = 4M_b \frac{\Delta}{L/2} + M_c \frac{\Delta}{h} + 4M_w \frac{\Delta}{L/2} H$$

$$P_w = \frac{8M_b}{L} + \frac{8M_w H}{L} + \frac{M_c L}{H}$$

What is L ? Length L that give min. $P_{ult.}$ is critical

$\frac{d P_{ult.}}{dL} = 0$ = defines L which gives min. $P_{ult.}$

$$L = \sqrt{8H \left(\frac{M_b + M_w H}{M_c} \right)}$$

APPENDIX "C"
CALCULATIONS FOR STRENGTH EVALUATION
OF SIX TEXAS BRIDGE RAILS

T101 BRIDGE RAIL
EVALUATION

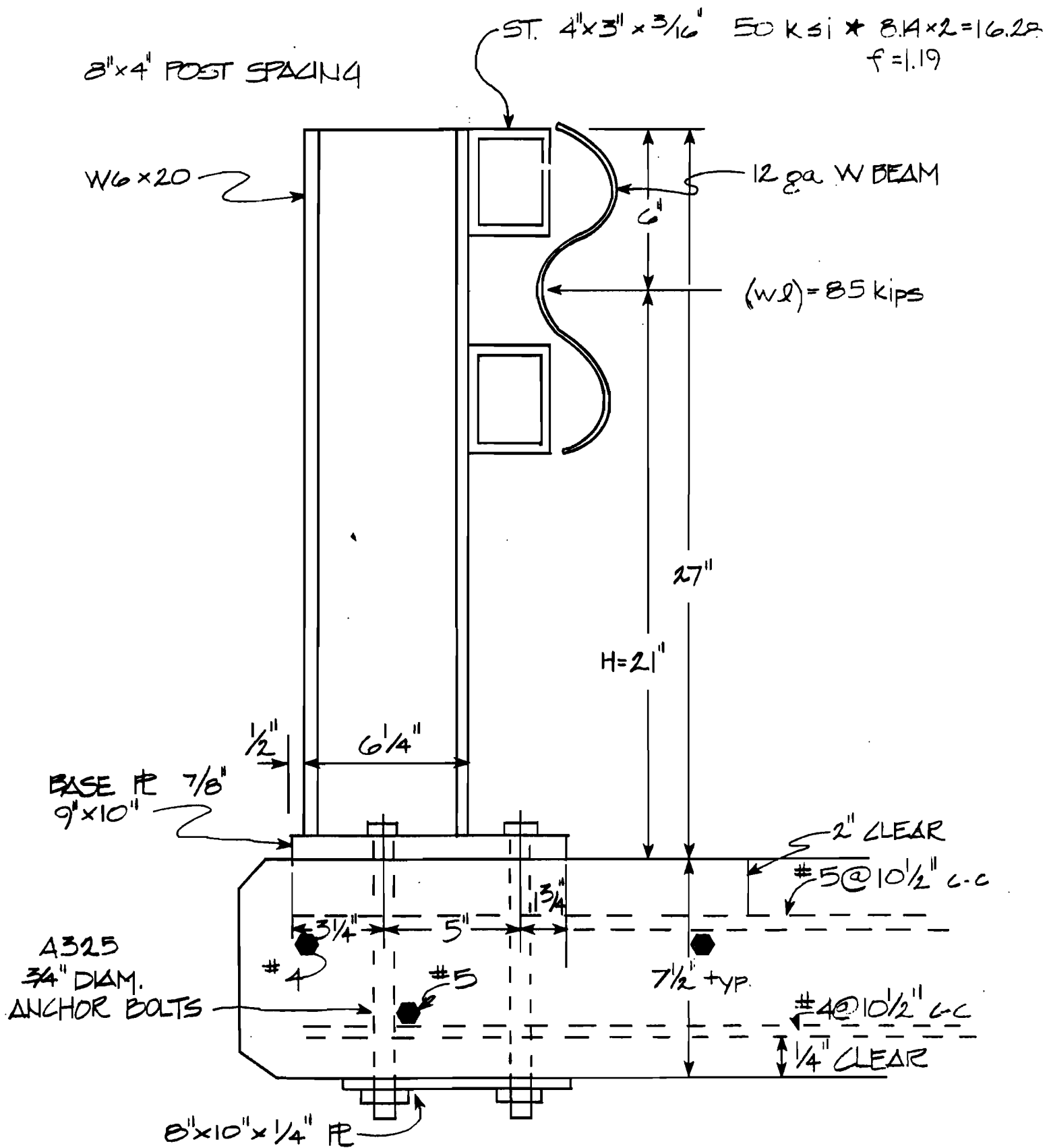

FIGURE C1.

BEAM

$$4" \times 3" \times 3/16 \quad F_y = 50 \text{ ksi} \quad 8.14 \text{ lb/ft}$$

$$S = 2.23 \text{ in}^3 \times 1.19 \quad Z = 2.65 \text{ in}^3$$

$$M_p = 2.65 \text{ in}^3 \times 50 \text{ ksi} = 132.7 \text{ k-in or } 11.06 \text{ k-ft}$$

$$\text{W Beam } S = 1.37 \quad M_y = 1.37 \times 40 \text{ ksi} = 54.8 \text{ k-in}$$

$$Z = 1.84 \quad = 4.57 \text{ k-ft}$$

$$\text{Total } M_p = 11.06 \text{ k-ft} \times 2 + 4.57 \text{ k-ft}$$

$$\text{Total } M_p = 26.69 \text{ k-ft (2 Tubes + W-beam)}$$

$$\text{Total Load } (w\ell) = \frac{8M_p}{L - \ell/2} \quad \text{where } \ell = 3.5 \text{ ft} \\ L = 8.33 \text{ ft}$$

$$(w\ell) = \frac{8 \times 26.69}{8.33' - 1.75} = \underline{\underline{32.4 \text{ kips}}} \quad \text{one span}$$

$$(w\ell) = \frac{8 \times 26.69}{16.67 - 1.75} = \underline{\underline{14.3 \text{ kips}}} \quad \text{two span}$$

$$(w\ell) = \frac{8 \times 26.69}{25' - 1.75} = \underline{\underline{9.2 \text{ kips}}} \quad \text{three span}$$

POST $W6 \times 20 \quad Z = 15.0 \text{ in}^3$

$$M_p = 15 \text{ in}^3 \times 36 \text{ ksi} = 540 \text{ k-in}$$

$$P = \frac{540 \text{ k-in}}{21 \text{ in}} = 25.7 \text{ kips}$$

$$\text{Mult} = 15 \text{ in}^3 \times 69 \text{ ksi} = 1035 \text{ k-in}$$

$$P_p(\text{ult.}) = \frac{1035 \text{ k-in}}{21 \text{ in}} = 49.3 \text{ kips}$$

ANCHOR BOLTS $3/4" \text{ A325 } A_{\text{tens.}} = .3345 \text{ in}^2$

$$T_{\text{ult.}} = \frac{28 \text{ kip}}{.7} = 40 \text{ kips each}$$

AISC 5-195

$$M_{\text{ult.}} = 40\text{k} \times 2 \times 7.5 \text{ in} + 40\text{k} \times 2 \times 2.5 \text{ in.}$$

$$M_{\text{ult.}} = 800 \text{ k-in}$$

$$P_{\text{ult.}} = \frac{800 \text{ k-in}}{21 \text{ in}} = 38.1 \text{ kips} = P_p$$

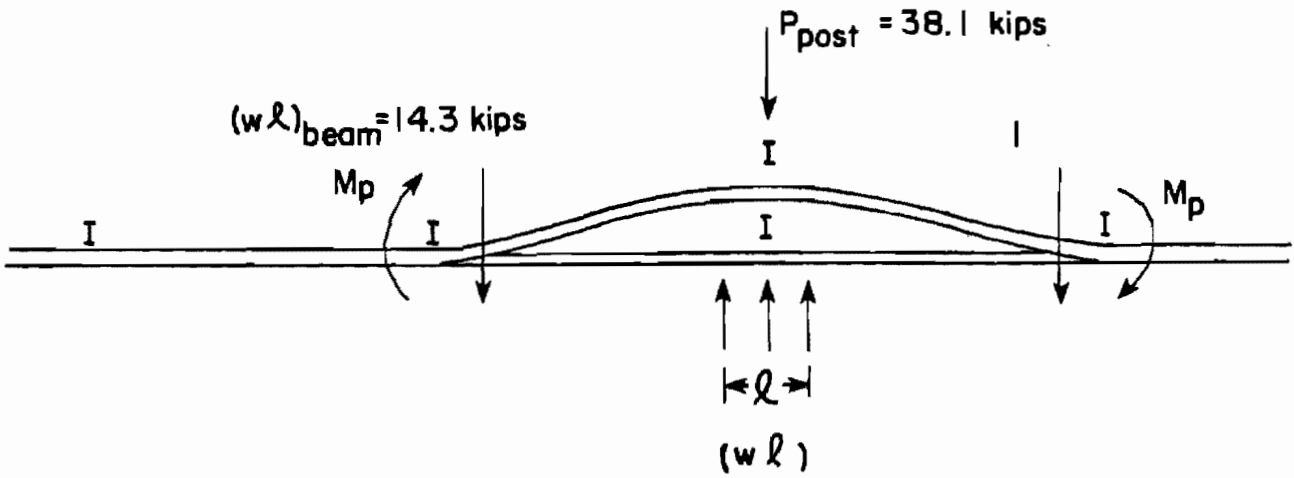

$$(wL)_{\text{ult.}} = 38.1 \text{ K} + 14.3 = 52.4 \text{ kips} \quad \text{Two Spans} - 16.7' \text{ rail}$$

So Total $(wL)_{\text{ult.}} = 2 \text{ Posts} + 3 \text{ Span Beam}$
 $= 2 \times 38.1 \text{ kips} + 9.2 \text{ kips}$
 $= \underline{85.4 \text{ kips}}$ 25 ft of rail 3 Spans
 3-SPAN FAILURE MODE 2 post Failed

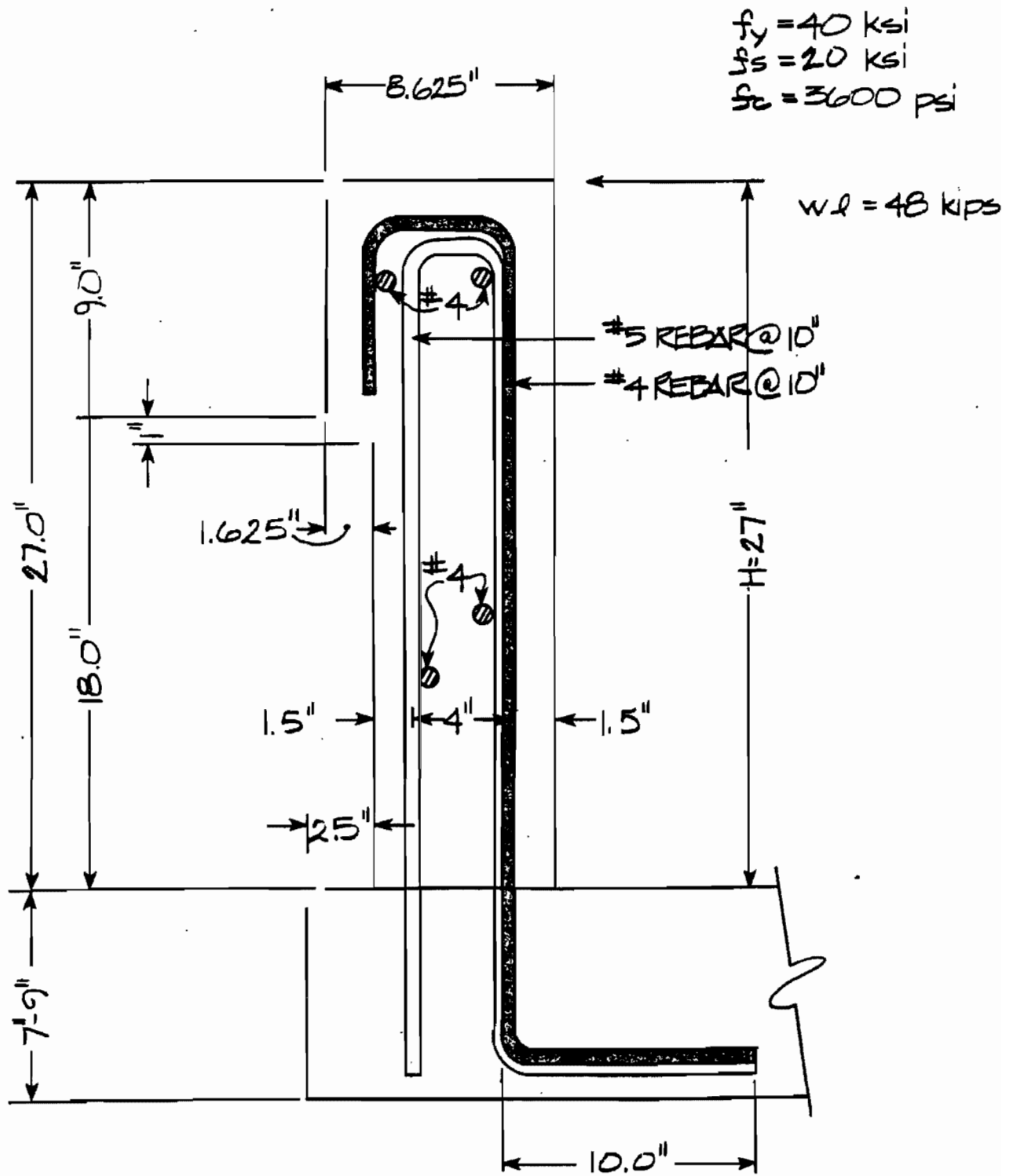

TRAFFIC RAIL BARRIER TYPE T201

FIGURE C2.

APPENDIX "C"

ANALYSIS OF TYPE T201 RAIL

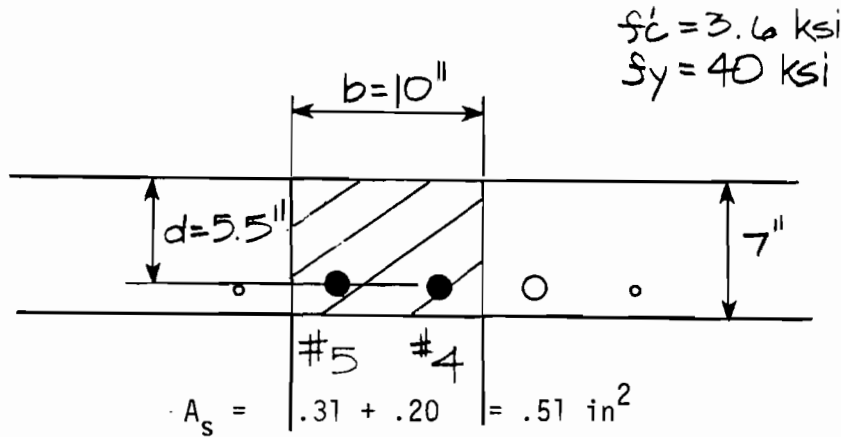

$$P = \frac{.51}{5.5 \times 10} = 0.009$$

$$A_s f_y = .85 f_c' b a$$

$$= .9\% \text{ steel}$$

$$a = \frac{.51 \times 40}{.85 \times 3.6 \times 10} = .66 \text{ in.}$$

$$P_b = \frac{B_1 \cdot .85 f_c'}{f_y} = \frac{87,000}{87,000 + f_y}$$

$$M_{ult.} = \phi A_s f_y (d - a/2)$$

$$= \frac{.85 \times .85 \times 3600 \times 87,000}{40,000 [87,000 + 40,000]}$$

$$= .9 \times .51 \times 40 (5.5 - .33)$$

$$= 4.45\%$$

$$= 94.86 \text{ k-in. per 10 in}$$

$$M_{ult.} = 113.83 \text{ k-in per ft of length} = M_c = 9.49 \frac{\text{k-ft}}{\text{ft}}$$

$$P_c = \frac{113.83 \text{ k-in}}{27 \text{ in}} = 4.2 \text{ kips/ft of rail}$$

WALL MOMENT M_w $d = 5 \text{ in. } b = 27 \text{ in. or } 2.25 \text{ ft}$

$$a = \frac{.2 \times 40}{.85 \times 3.6 \times 27} = .097 \text{ in.}$$

$$M_{ult.} = .9 \times .2 \times 40 (5 - .043) = 35.7 \text{ k-in or } 2.97 \text{ k-ft}$$

$$M_w = 1.32 \text{ k-ft/ft}$$

$$\text{SHEAR CHECK } V_u = V_u \phi \text{ bod}$$

$$= .12 \times .85 \times 12 \times 5.5 = 6.73 \text{ k/ft of rail}$$

$$M_b = \phi A_s f_y (d - 9/2) \quad \text{TOP BEAM MOMENT}$$

$$a = \frac{.2 \times 40}{.85 \times 3.6 \times 10} = .26 \text{ in.}$$

$$M_b = .9 \times .2 \times 40 (6.625 - \frac{.26}{2})$$

$$M_b = 45.8 \text{ k-in or } 3.82 \text{ k-ft}$$

YIELD LINE ANALYSIS - CONCENTRATED LOAD

$$L = \sqrt{8H \left(\frac{M_b + M_w H}{M_c} \right)}$$

$$= \sqrt{8 \times 2.25 \left(\frac{3.82 + 1.32 \times 2.25}{9.49} \right)}$$

$$L_{cr} = 3.59 \text{ ft}$$

$$P_{ult.} = \frac{8M_b}{L} + \frac{8M_w H}{L} + \frac{M_c L}{H}$$

$$= \frac{8 \times 3.82}{3.59} + \frac{8 \times 1.32 \times 2.25}{3.59} + \frac{9.49 \times 3.59}{2.25}$$

$$= 8.51 + 6.62 + 15.14$$

$$P_{ult.} = 30.3 \text{ kips}$$

$$7.2 \text{ ft}$$

Concentrated Load at Top of wall

is too conservative

YIELD LINE ANALYSIS - "DISTRIBUTED LOAD"

$$\begin{aligned}
 L_{cr} &= \frac{\ell}{2} + \sqrt{\left(\frac{\ell}{2}\right)^2 + 8H \left(\frac{M_b + M_{WH}}{M_c}\right)} \\
 &= \frac{3.5}{2} + \sqrt{\left(\frac{3.5}{2}\right)^2 + 8 \times 2.25 \left(\frac{3.82 + 1.32 \times 2.25}{9.49}\right)} \\
 &= 1.75 + \sqrt{3.06 + 12.88} \\
 &= 1.75 + 4.00
 \end{aligned}$$

$$L = 5.75 \text{ ft}$$

$$\begin{aligned}
 (w\ell)_{ult.} &= \frac{8M_b}{L - \ell/2} + \frac{8M_{WH}}{L - \ell/2} + \frac{M_c L^2}{H(L - \ell/2)} \\
 &= \frac{8 \times 3.82}{5.75 - 1.75} + \frac{8 \times 1.32 \times 2.25}{5.75 - 1.75} + \frac{9.49 \times 5.75^2}{2.25 (5.75 - 1.75)} \\
 &= 7.64 + 5.94 + 34.86
 \end{aligned}$$

$$(w\ell)_{ult.} = 48.44 \text{ kips}$$

Total Length of Wall resisting load is

$$\frac{48.44 \text{ kips}}{4.2 \text{ kips/ft}} = 11.53 \text{ ft}$$

$f_c = 40 \text{ ksi}$
 $f_s = 60 \text{ ksi}$

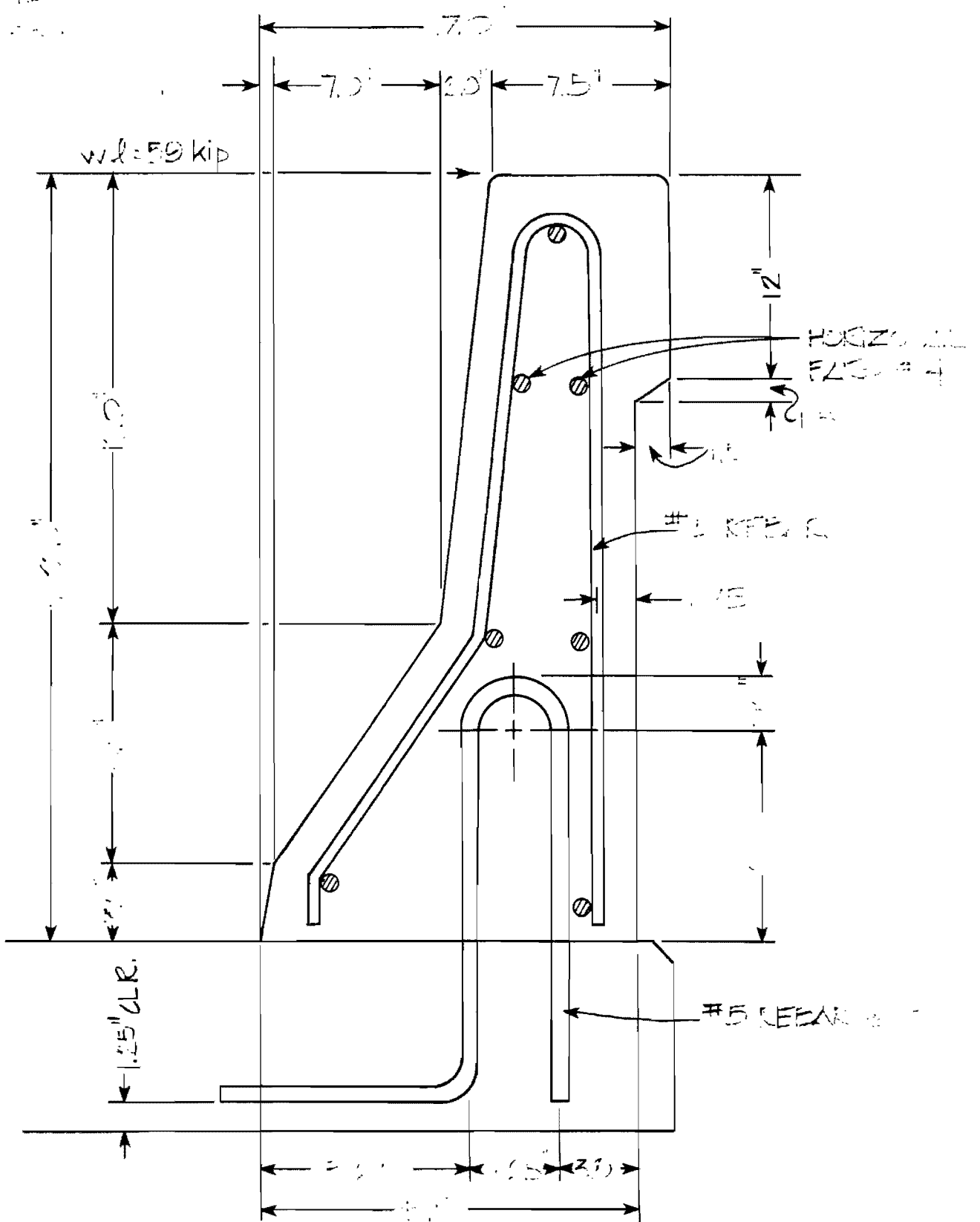

TRAFFIC RAIL BARRIER TYPE T5
 FIGURE C3

ANALYSIS OF TYPE T5 RAIL

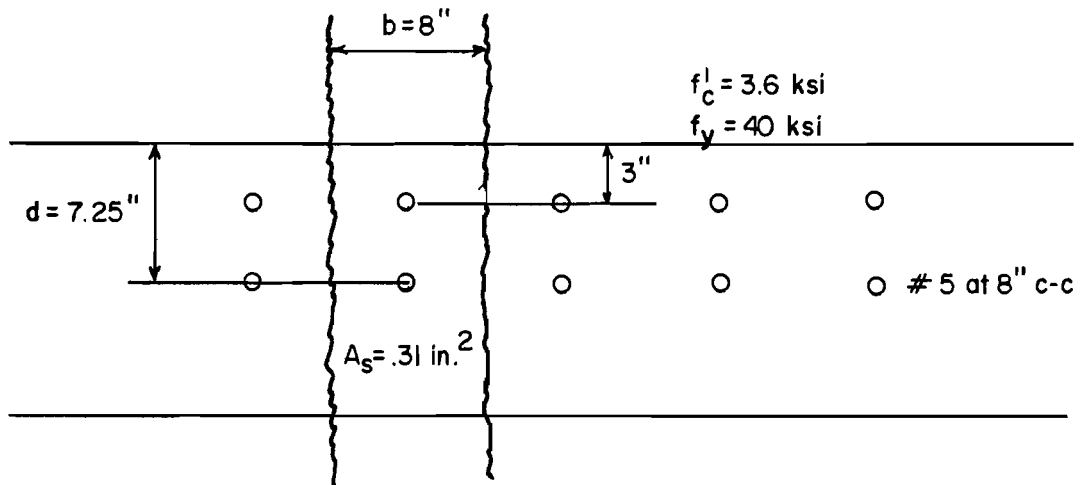

$$A_s f_y = .85 f'_c b a$$

$$a = \frac{A_s f_y}{.85 f'_c b} = \frac{.62 \times 40}{.85 \times 3.6 \times 8}$$

$$a = 1.01 \text{ in}$$

$$P = \frac{.62 \text{ in.}^2}{7.25 \times 8} = .00534$$

$$P = 1.068\% \text{ steel}$$

$$P_b = 4.45\%$$

$$\text{Mult} = \phi A_s f_y (d - 1/2)$$

$$= .9 \times .31 \times 40 (7.25 - .5) + .9 \times .31 \times 40 (2.5 - .5)$$

$$= 75.33 + 22.32 = 97.7 \text{ kip-in per 8 in.}$$

$$\text{Mult} = M_c = 146.5 \text{ kip-in per foot of rail}$$

$$P_c = \frac{146.5 \text{ kip-in}}{32 \text{ in.}} = 4.58 \text{ kips/ft of rail}$$

$$M_c = 12.2 \frac{\text{k-ft}}{\text{ft}}$$

$$\text{SHEAR } V_u = u \phi b o d = .12 \times .85 \times 12 \times 7.25$$

$$= 8.87 \text{ kips/ft of rail}$$

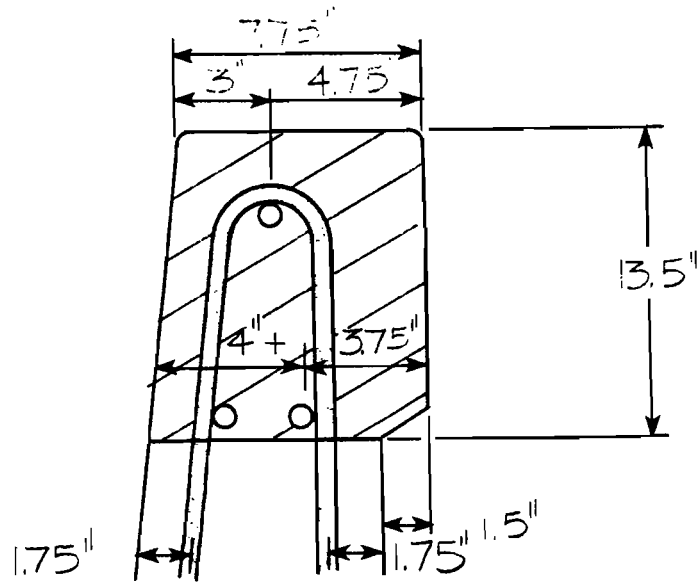

Evaluation of Top Beam Moment M_b approximately assume $b = 13.5$ in. min.
 $d = 3.5$ in. $A_s = 2 \times .20 = .40$ in.²

$$a = \frac{A_s f_y}{.85 f_c' b} = \frac{.40 \times 40}{.85 \times 3.6 \times 13.5} = .387 \text{ in.}$$

$$\text{Mult} = \phi A_s f_y (d - a/2)$$

$$= .9 \times .4 \times 40 (3.5 - .2) = 47.5 \text{ kip in.}$$

$$\text{Mult} = .9 \times .4 \times 40 (5.1 - .2) = 70.6 \text{ kip-in.}$$

$$\text{Assume } M_w = 72 \text{ k-in. or } \frac{6 \text{ k-ft}}{2.67 \text{ ft}} = 2.25 \frac{\text{k-ft}}{\text{ft}}$$

Use Avg.

$$M_b = 59 \text{ kip-in } 4.92 \text{ kip-ft}$$

YIELD LINE ANALYSIS - "DISTRIBUTED LOAD"

$$L = \frac{\ell}{2} + \sqrt{\left(\frac{\ell}{2}\right)^2 + \frac{8H(M_b + M_w H)}{M_c}} \quad \ell = 3.5'$$

$$= 1.75 + \sqrt{1.75^2 + 8 \times 2.67 \left(\frac{4.92 + 2.25 \times 2.67}{12.2}\right)}$$

$$L = 1.75 + 4.71 = 6.46$$

$$(w\ell)_{ult.} = \frac{8M_b}{L - \ell/2} + \frac{8M_w H}{L - \ell/2} + \frac{M_c L^2}{H(L - \ell/2)}$$

$$= \frac{8 \times 4.92}{4.71} + \frac{8 \times 2.25 \times 2.67}{4.71} + \frac{12.2 \times 6.46^2}{2.67 \times 4.71}$$

$$= 8.4 + 10.2 + 40.5$$

$$(w\ell)_{ult.} = 59 \text{ kips}$$

$$\frac{59}{4.58 \text{ k/ft}} = 12.9 \text{ ft}$$

$f_y = 60 \text{ ksi}$
 $f_c = 3600 \text{ psi}$

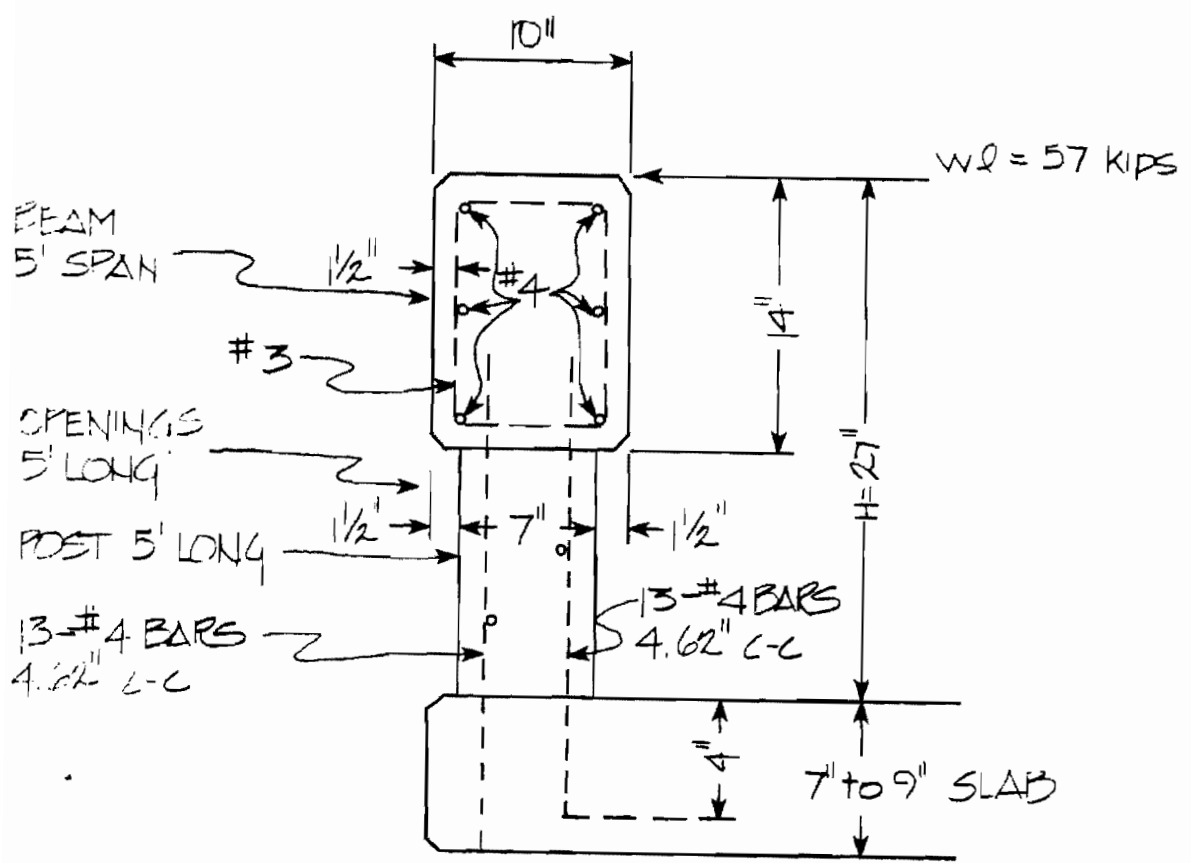

TRAFFIC RAIL TYPE T202
 FIGURE C4

ANALYSIS OF TYPE T202 RAIL

WALL MOMENT CAPACITY

$$a = \frac{.2 \times 60}{.85 \times 3.6 \times 4.62} = .85 \text{ in for } b = 4.62''$$

$$d = 5.5$$

$$M_u = .9 \times 60 \times .2 (5.5 - .425) = 54.81 \text{ k-in/4.62''}$$

$$M_c = 142.4 \text{ k-in/ft}$$

$$M_c = 11.86 \text{ k-ft/ft}$$

$$5.27 \text{ kips/ft of wall}$$

BEAM MOMENT CAPACITY

$$b = 14'' \quad d = 8''$$

$$a = \frac{Asf_y}{.85 f_c' b}$$

$$p = \frac{As}{bd} = \frac{.6}{8 \times 14} = .0054$$

$$= \frac{.60 \times 60}{.85 \times 3.6 \times 14}$$

$$p_{max} = .0192$$

$$a = .84''$$

$$M_b(ult.) = \phi f_y A_s (d - a/2)$$

$$= .9 \times 60 \times .6 (8 - .42) = 245.6 \text{ k-in}$$

$$M_b = 20.47 \text{ kip-ft}$$

SHEAR IN BEAM

$$V_u H = 2 \sqrt{f_c'} \quad bd$$

$$= .11 \times 14 \times 8.25$$

$$= 12.71 \text{ kips} \times 2 = 25.42$$

YIELD LINE ULTIMATE "DISTRIBUTED LOAD"

$$M_c = 11.86 \frac{\text{k-ft}}{\text{ft}} \quad M_b = 20.47 \text{ k-ft}$$

$$G = 5 \text{ ft} \quad \ell = 3.5 \text{ ft} \quad H = 2.25 \text{ ft}$$

$$\begin{aligned} L_{er} &= \frac{\ell}{2} + \sqrt{\left(\frac{\ell}{2}\right)^2 + \frac{8H M_b}{M_c} - \frac{G\ell}{2}} \\ &= 1.75 + \sqrt{(1.75)^2 + \frac{8 \times 2.25 \times 20.47}{11.86} - \frac{5 \times 3.5}{2}} \\ &= 1.75 + \sqrt{3.06 + 31.07 - 8.75} \\ &= 1.75 + 5.04 \end{aligned}$$

$$L_{cr} = 6.79 \text{ ft}$$

$$\begin{aligned} (w\ell)_{ult.} &= \frac{8M_b}{L - \ell/2} + \frac{M_c L (L-G)}{H (L - \ell/2)} \\ &= \frac{8 \times 20.47}{5.04} + \frac{11.86 \times 6.79 (6.79 - 5)}{2.25 \times 5.04} \\ &= 32.5 \text{ kips} + 12.7 \text{ kips} \end{aligned}$$

$$(w\ell)_{ult.} = 45 \text{ kips}$$

$$\frac{45 \text{ kips}}{5.27 \text{ k/ft wall}} = 8.54 \text{ ft of wall}$$

T202 ULTIMATE LOAD USING THREE
SPAN FAILURE MODE (FIG. 12)

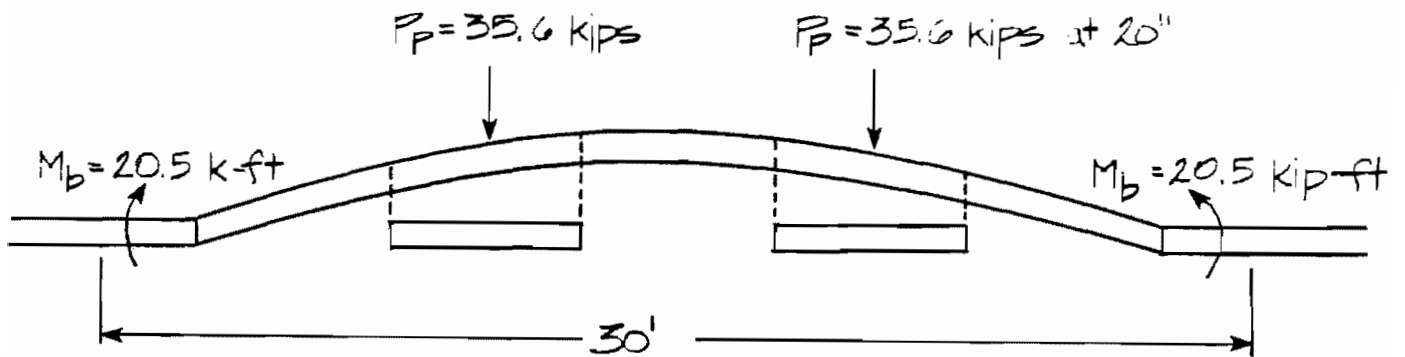

$$P_p = 11.86 \frac{\text{k-ft}}{\text{ft}} \times 5 \text{ ft} \times \frac{1}{1.66 \text{ ft}} = 35.6 \text{ kips at } H = 20'' \text{ or } 1.67'$$

$$(w_{\ell}) = \frac{8 M_b}{L - \ell/2} = \frac{8 \times 20.5}{30 - 1.75} = 5.8 \text{ kips at } 20 \text{ in.}$$

$$\text{Tot. } (w_{\ell}) = 35.6 + 35.6 + 5.8 = 77 \text{ kips} = 2\ell \text{ at } H = 20 \text{ in.}$$

$$M_L = 77 \text{ k} \times 20 \text{ in.} = 1540 \text{ k-in.}$$

for $H = 27 \text{ in.}$

$$w_{\ell} = 57 \text{ kips}$$

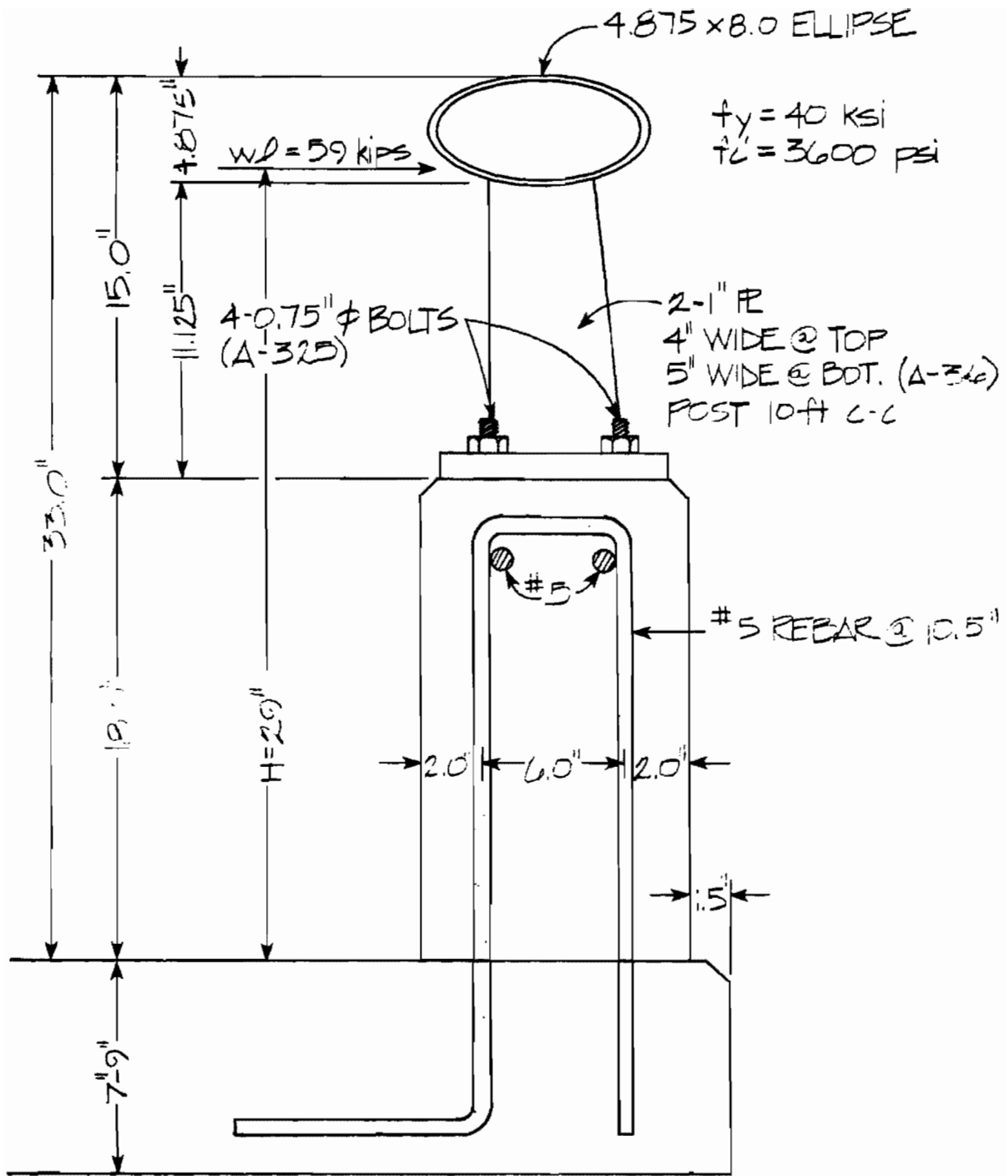

TRAFFIC RAIL BARRIER TYPE T4
 FIGURE C5

ANALYSIS OF TYPE T4 RAIL

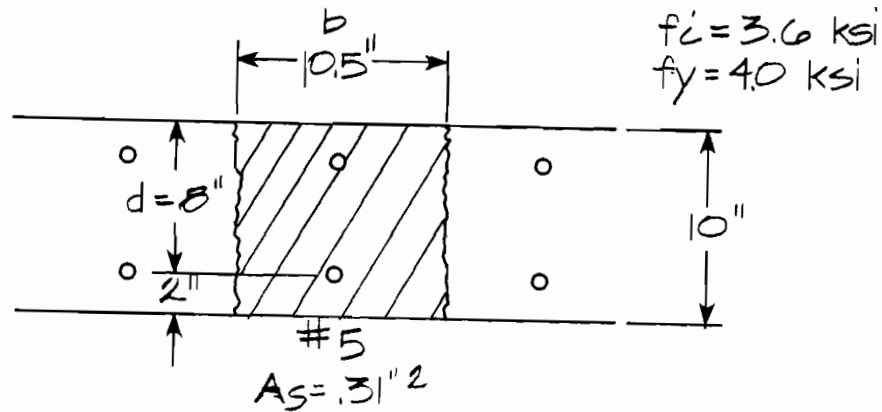

$$a = \frac{.62 \times 40}{.85 \times 3.6 \times 10.5} = .77 \text{ in.}$$

$$P = \frac{.62}{8 \times 10.5} = .00369$$

$$\begin{aligned} M_{ult.} &= \phi A_s f_y (d - a/2) \\ &= .9 \times .31 \times 40 (8 - .38) + .9 \times .31 \times 40 (2 - .38) \\ &= 85.0 \text{ k-in.} + 18.1 = 103.1 \text{ k-in per } 10 \frac{1}{2}'' \end{aligned}$$

$$P = .74\%$$

$$P_b = 4.45\%$$

$$M_{ult.} = 117.8 \text{ kip-in per ft of rail} = M_c = 9.82 \text{ k-ft/ft}$$

$$P_c = \frac{117.8 \text{ k-in/ft}}{30.56 \text{ in.}} = 3.85 \text{ kips/ft of rail}$$

POST 2-1 in. R 5 in. wide A36 steel - 10ft centers

$$I_x = \frac{bd^3}{4} = \frac{2 \times 5^3}{4} = 12.5 \text{ in.}^3$$

$$M_p = ZF_y = 12.5 \text{ in.}^3 \times 36 \text{ k/in}^2 = 450 \text{ k-in. per } 10 \text{ ft}$$

$$M_p = 45 \text{ kip-in per ft of rail}$$

$$P_{post} = \frac{450}{11.56} = 39 \text{ kips}$$

$$P_c = \frac{45 \text{ k-in}}{11.56 \text{ in.}} = 3.9 \text{ kips/ft of rail}$$

ANCHOR BOLTS 2-3/4 in. diam $A_{ten} = .3345 \text{ in.}^2$ $T_{ult} = 40 \text{ kips}$

Mult = 80 kips x 6 in. = 480 k-in per 10 ft of rail

$P_c = 48 \text{ k-in}/12.56 \text{ in.} = 3.82 \text{ kips/ft of rail}$ $P_p = 38.2 \text{ kips}$

RAIL 4 7/8 in. x 8 in. Ellipse with .188 in. wall

Use properties of 4 in. x 8 in. x .188 in. rectangular tube

$A = 4.24 \text{ in.}^2$ $S_x = 8.71 \text{ in.}^3$ $S_y = 5.96 \text{ in.}^3$
assume $f = 1.14$

$M_p = 36 \text{ ksi} \times 8.71 \text{ in.}^3 \times 1.14 = 357 \text{ k-in. or } 29.8 \text{ k-ft}$

$P_u = \frac{8M_p}{L} = \frac{8 \times 29.8 \text{ k-ft}}{10 \text{ ft}} = 24 \text{ kips Con. Load for 10 ft rail span}$

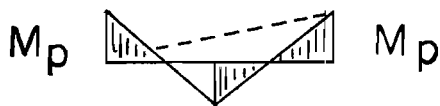

$wL = \frac{12 M_p}{L} = \frac{12 \times 29.8 \text{ k-ft}}{10 \text{ ft}} = 36 \text{ kips distributed load for 10 ft rail span}$

$w = 3.6 \text{ kips/ft of rail}$

Distributed Load over 3.5 ft of Rail - 42 in. tire diameter

$(w)_{uH} = \frac{\frac{\ell = 3.5 \text{ ft}}{8M_p}}{L - \ell/2} = \frac{8 \times 29.8}{10 - 1.75} = 28.9 \text{ kips}$

RAIL $(w\ell)_{ult.} = 29 \text{ kips} = P_R$
distributed over $\ell = 3.5 \text{ ft}$ one span

Find P'_R when post yields when impacted and rail covers two spans--

$P'_R = \frac{8M_p}{L - \ell/2} = \frac{8 \times 29.8}{20 - 1.75} = 13 \text{ kips} = P'_R$ two span

$$A_s = .62$$

$$a = \frac{.62 \times 40}{.85 \times 3.6 \times 18} = .45''$$

$$\begin{aligned} M_b &= .9 \times .31 \times 40 (7.25 - .22) + .9 \times .31 \times 40 (2.94 - .22) \\ &= 78.5 \text{ k-in} + 30.4 \text{ k-in} = 108.9 \text{ k-in} \end{aligned}$$

$$M_b = 9.07 \text{ k-ft}$$

YIELD LINE ANALYSIS OF WALL - "DISTRIBUTED LOAD"

$$L = \frac{\ell}{2} + \sqrt{\left(\frac{\ell}{2}\right)^2 + \frac{8H}{M_c} \left(\frac{M_b + M_w H}{M_c}\right)}$$

$$= 1.75 + \sqrt{1.75^2 + 8 \times 1.5 \left(\frac{9.07}{9.82}\right)}$$

$$= 1.75 + 3.76$$

$$L = 5.51 \text{ ft}$$

$$\begin{aligned} (w\ell)_{ult.} &= \frac{8M_b}{L - \ell/2} + \frac{8M_w}{L - \ell/2} + \frac{M_c L^2}{H(L - \ell/2)} \\ &= \frac{8 \times 9.07}{5.51 - 1.75} + \frac{9.82 \times 5.51^2}{1.5 (5.51 - 1.75)} \end{aligned}$$

$$= 19.3 \text{ kips} + 52.9 \text{ kips}$$

$$(w\ell)_{ult.} = 72.2 \text{ kips} = P_w \text{ WALL } h_w = 18 \text{ in.}$$

$$P_{ult.} \text{ RAIL} = 29 \text{ kips} \quad \text{RAIL } h_R = 30.56 \text{ in.}$$

$$P_R' = 13 \text{ kips}$$

$$P_p = 38 \text{ kips}$$

COMBINED ANALYSIS OF COMPOSITE T4 RAIL IMPACT AT POST

$$P_w' = \frac{M_L - P_p h_R}{h_w} \quad M_L = P_w h_w = 72^k \times 18'' = 1296$$

$$= \frac{1296 - 38 \text{ kips} \times 30.56}{18} = \frac{1296 - 1161}{18} = 7.5 = P_w'$$

$$R_{\max} = P_p + P_R' + P_w = 38^k + 13^k + 7.5^k = \underline{59 \text{ kips} = R}$$

$$H = 29 \text{ in.}$$

$$H = \frac{38 \times 30.56'' + 13 \times 30.56 + 7.5 \times 18}{58.5}$$

$$= \frac{1161 + 397 + 135}{58.5} = 28.94$$

$$\text{no } R = P_p + P_R' = 38 + 13 = \underline{\frac{51 \text{ kips} = R}{30.5 \text{ in} = H}}$$

Impact at Mid-Span

$$R = P_R + P_w$$

$$= 29k + 72k = 101 \text{ kips}$$

$$H = \frac{29 \times 30.56 + 72 \times 18}{101} = \frac{866 + 1296}{101} = 21.4''$$

$$\text{for } H = 27'' \quad R = \frac{1948}{27} = 72 \text{ kips}$$

$$\text{for } H = 30.6 \quad R = \frac{1948}{30.6} = 63.7 \text{ kips}$$

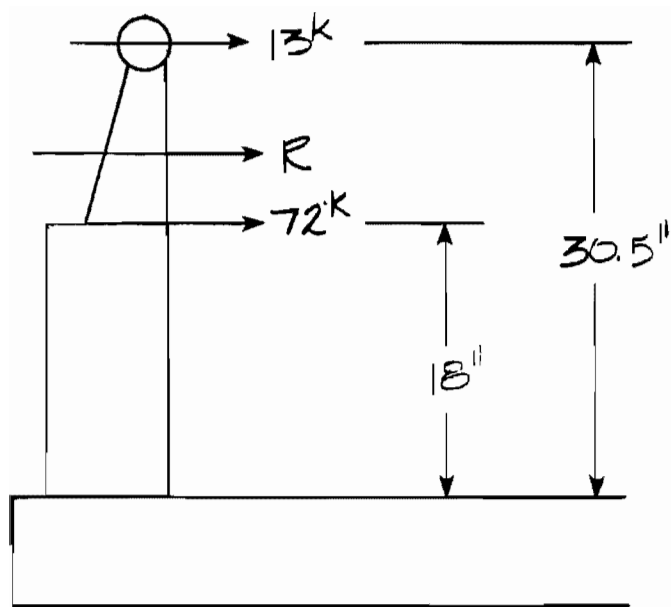

$$R = 72 + 13 = 85 \text{ kips}$$

$$\bar{y} = \frac{13^k \times 30.5^k + 72^k \times 18^k}{85^k}$$

$$= \frac{396.5 + 1296}{85} = 19.9$$

say H = 20 in.

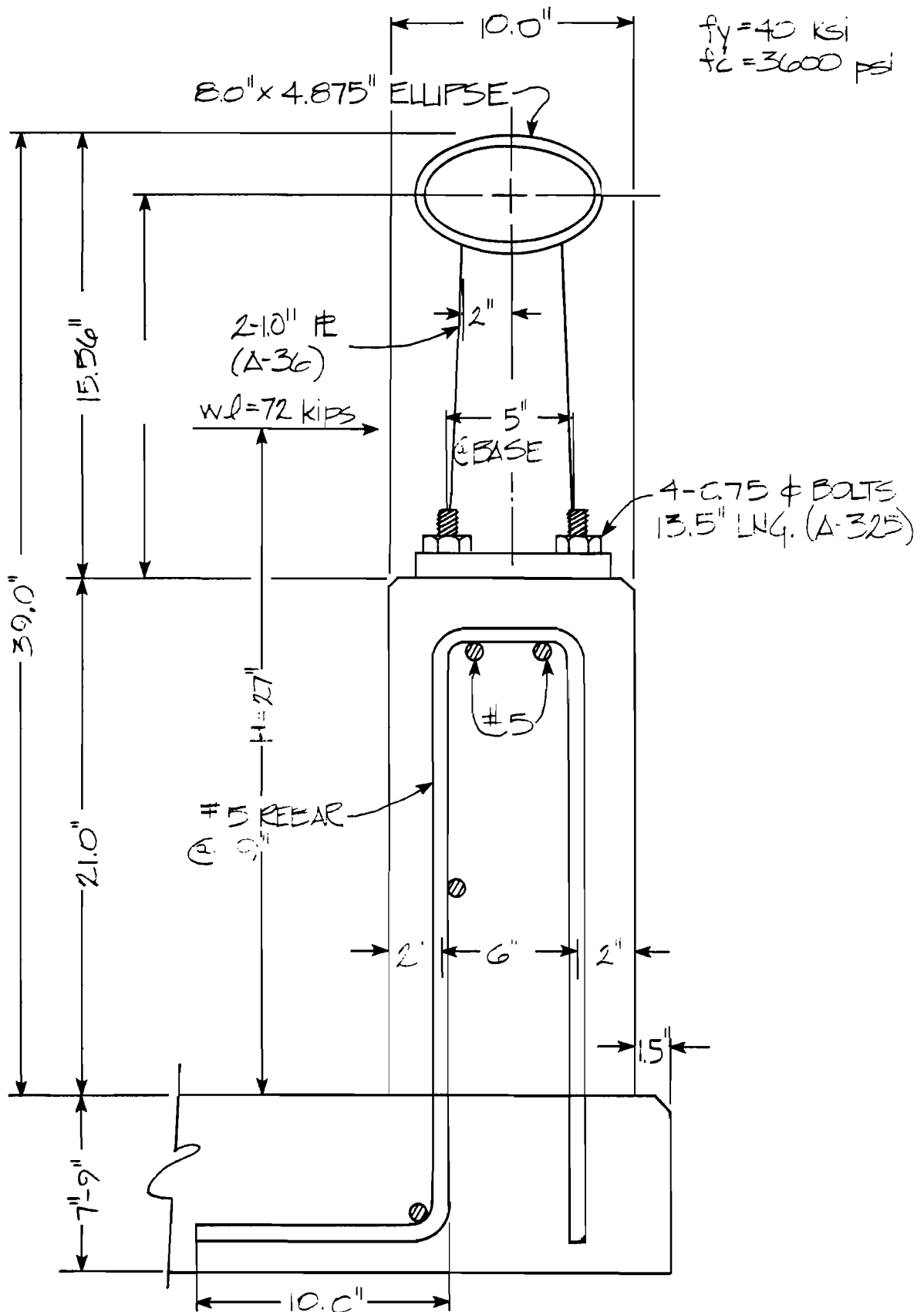

TRAFFIC RAIL BARRIER TYPE C4
FIGURE C6.

ANALYSIS OF TYPE C4 RAIL

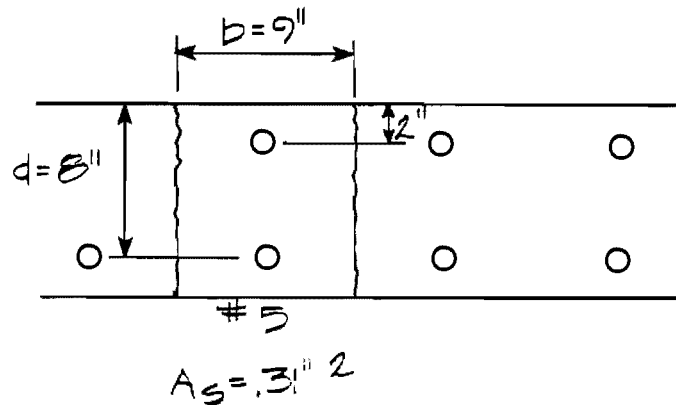

$$a = \frac{A_s f_y}{.85 f_c' b} = \frac{.62 \times 40}{.85 \times 3.6 \times 9} = .90 \text{ in.}$$

$$\begin{aligned} \text{Mult} &= .9 \times .31 \times 40 (8 - .45) + .9 \times .31 \times 40 (2 - .45) \\ &= 84.3 \text{ k-in.} \quad + 17.3 = 101.6 \text{ k-in/9 in.} \end{aligned}$$

$$\text{Mult} = 135.5 \text{ kip-in. per foot} = M_c = 11.3 \text{ k-ft/ft}$$

$$P_c = \frac{135.5 \text{ k-in}}{36.58 \text{ in.}} = 3.70 \text{ kips/ft}$$

Concrete
Parapet

POSTS - 2-1 in. \times 5 in. wide A36 = 10ft centers

$$M_p = Z F_y = 12.5 \text{ in}^3 \times 36 \text{ ksi} = 450 \text{ k-in. per 10 ft}$$

$$M_p = 45 \text{ k-in per ft} \quad P_p = \frac{450 \text{ k-in}}{15.58} = 28.9 \text{ kips}$$

$$P = \frac{45 \text{ k-in}}{14.56 \text{ in}} = 3.09 \text{ kips/ft of rail} \quad P_p = 29 \text{ kips}$$

RAIL "Same as T4" Pult - 24 kips for 10 ft span

$$P'_R = 13 \text{ kips} \quad \begin{array}{l} 3.6 \text{ kips per ft if distributed load} \\ \text{two span} \quad (wL)uH = 36 \text{ kip distributed load on 10 ft span} \end{array}$$

$$(wL)uH - 29 \text{ kips} = P_R$$

$$L = 3.5' \text{ distributed load one span} \quad h_R = 36.58 \text{ in.}$$

ANCHOR BOLTS Same as T4 Rail

$$P_p = \frac{480 \text{ k-in}}{15.56 \text{ in}} = 30.8 \text{ kips}$$

Post Controls $P_p = 29 \text{ kips}$

BEAM

$$a = \frac{.93 \times 40}{.85 \times 3.6 \times 21} = .58''$$

$$\begin{aligned} M_b &= .9 \times .31 \times 40 (7.25 - .29) + .9 \times .31 \times 40(2.94 - .29) \\ &\quad + .9 \times .31 \times 40(5 - .29) \\ &= 77.7 \text{ k-in} + 29.6 + 52.6 \end{aligned}$$

$$M_b = 160 \text{ k-in} = 13.3 \text{ k-ft}$$

YIELD LINE ANALYSIS OF WALL - "DISTRIBUTED LOAD"

$$L = \frac{\ell}{2} + \sqrt{\left(\frac{\ell}{2}\right)^2 + 8H \left(\frac{M_b + M_w H}{M_c}\right)}$$

$$= 1.75 + \sqrt{1.75^2 + 8 \times 1.75 \times \frac{13.3}{11.3}}$$

$$= 1.75 + 4.42$$

$$L = 6.17$$

$$(w\ell)_{ult.} = \frac{8M_b}{L - \ell/2} + \frac{8M_w H}{L - \ell/2} + \frac{M_c L^2}{H \left(L - \ell/2\right)}$$

$$= \frac{8 \times 13.3}{4.42} + \frac{11.3 \times 6.17^2}{1.75 \times 4.42}$$

$$= 24.1 \text{ kips} + 55.6 \text{ kips}$$

$$(w\ell)_{ult.} = 80 \text{ kips} = P_w \text{ WALL} \quad h_w = 21 \text{ in.}$$

$$P_R = 29 \text{ kips} = P_R \text{ RAIL} \quad h_R = 36.58 \text{ in. one span}$$

$$P_R' = 13 \text{ kips two span}$$

$$P_p = 29 \text{ kips}$$

COMBINED ANALYSIS OF COMPOSITE C4

Impact at Post $M_L = P_w \times h_w = 80^k \times 21" = 1680 \text{ k-in.}$

$$P_w' = \frac{P_w h_w - P_p h_r}{h_w}$$

$$P_w' = \frac{80^k \times 21" - 29^k \times 36.58"}{21"} = \frac{1680 - 1061}{21} = 29.5 \text{ kips}$$

$$R = P_p + P_w' + P_R' = 29 + 29.5 + 13 = 71.5 \text{ kips}$$

$$H = \frac{P_p h_R + P_w' h_w + P_R' h_R}{R}$$

$$= \frac{29 \times 36.58 + 29.5 \times 13" + 13 \times 36.58}{71.5} = \frac{1921}{71.5} = 26.9"$$

If we assume $H = 36.58"$

$$R = P_p + P_R' = 29 + 13 = 42 \text{ kips}$$

$$\text{or } R = P_w + P_R' = 80 + 13 = 93 \text{ kips } H = 23 \text{ in.}$$

$$H = \frac{80 \times 21 + 13 \times 36.6}{93} = \frac{1680 + 476}{93} = 23.2$$

If $H = 36.6"$ $R = 42^k$

$$R = P_p + P_R' = 29 + 13 = 42$$

IMPACT AT MID-SPAN

$$R = P_R + P_w$$

$$= 29 + 80 = 109 \text{ kips}$$

$$H = \frac{P_R h_R + P_w h_w}{R}$$

Does Not Control

$$= \frac{29 \times 36.58 + 80 \times 21}{109} = \frac{1061 + 1680}{109} = 25.1"$$

TYPICAL SLAB OVERHANG

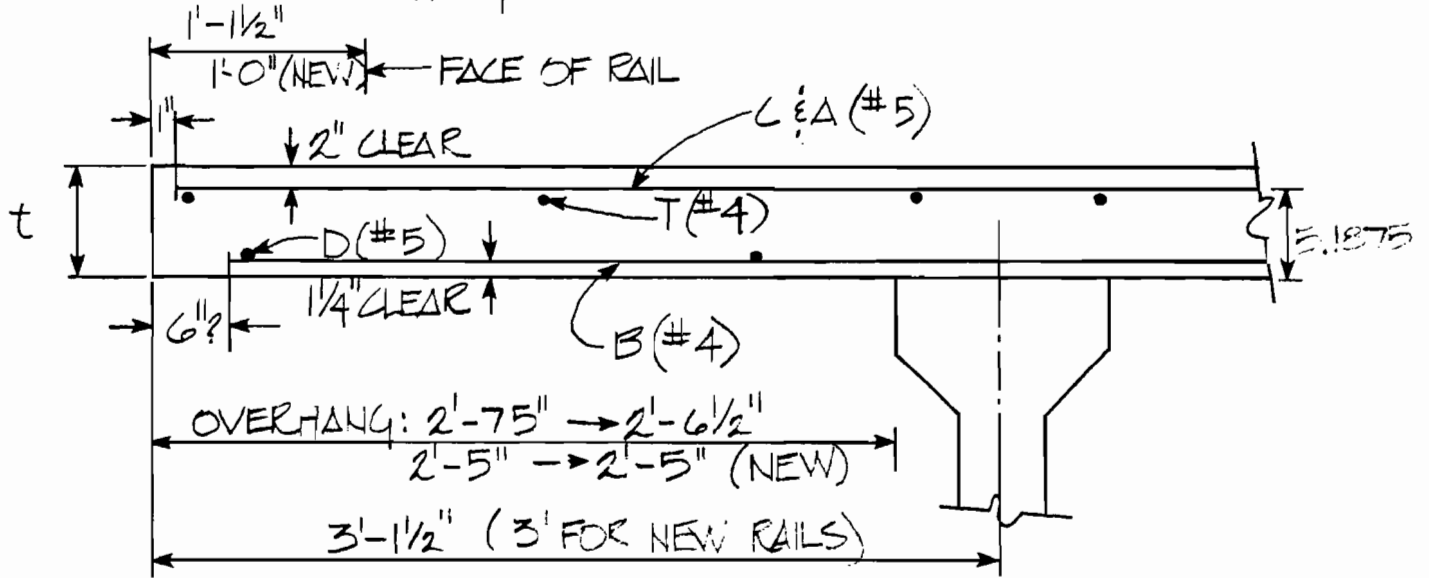

Standard Roadways	t	B, C and A Bars Max Bar Spacing	Overhang
26 h	8 3/4"	12"	2' - 7 1/2"
34 HS 40HS	7 1/2"	10 1/2"	
44 HS	7 1/4"	11"	
48 HS	7 1/2"	10 1/2"	
Others			Max Overhang
	6 3/4"	12"	2' - 11"
	7"	11 1/2"	3' - 0 1/2"
	7 1/4"	11"	3' - 2 1/2"
	7 1/2"	10 1/2"	3' - 4 1/2"
	7 3/4"	10"	3' - 7"
	8"	9 1/2"	3' - 10"

Rail types T101 and T301 have added anchorage plates at level of top slab reinforcement

FIGURE C7. TEXAS BRIDGE DECKS

BRIDGE DECK or SLAB ANALYSIS

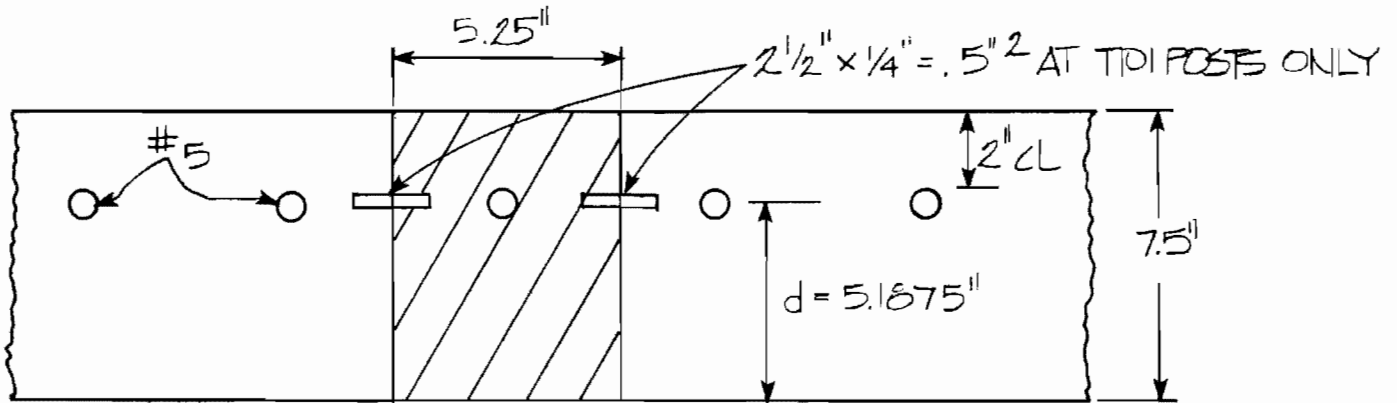

$$a = \frac{.31 \times 40}{.85 \times 3.6 \times 5.25} = .77''$$

$$M_{ult.} = .9 \times .31 \times 40 \times 5.19 - \frac{.77}{2} = 53.6 \text{ k-in per } 5.25'' \quad M_{ult.} = 10.2 \text{ k-ft per ft SLAB}$$

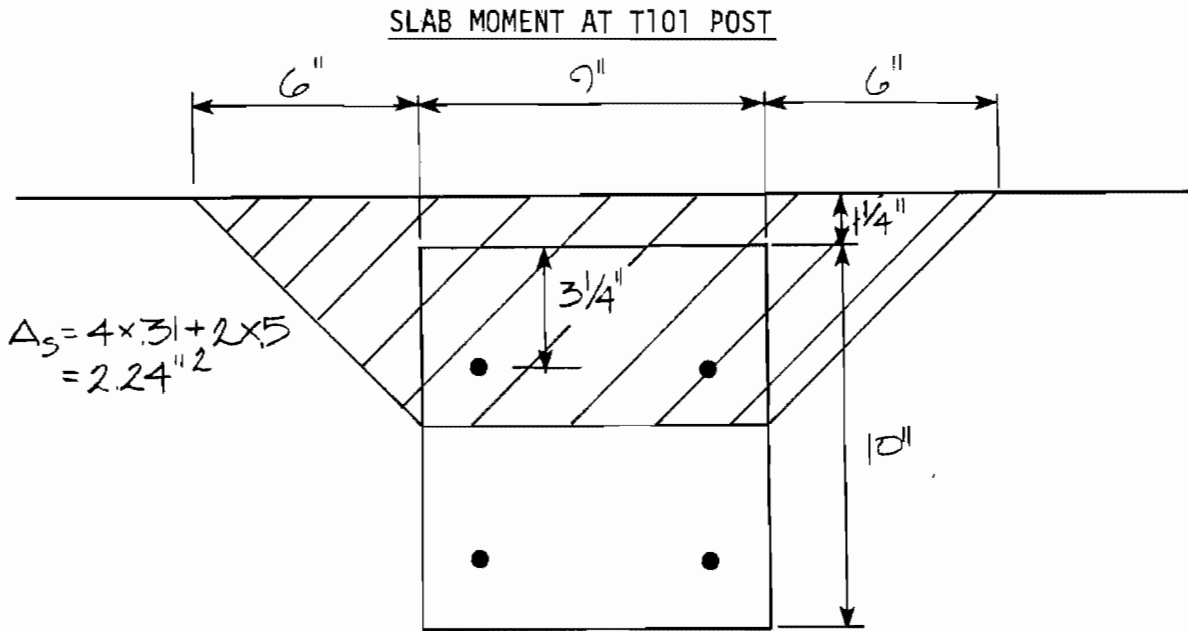

$$a = 4 \times .31 + 2 \times .5 = 2.24 \text{ in}^2$$

$$a = \frac{2.24 \times 40}{.85 \times 3.6 \times 21} = 1.4''$$

$$M_{ult.} = .9 \times 2.24 \times 40 (5.19 - .7) = 362 \text{ k-in per } 21'' = 30.2 \text{ k-ft}$$

If Steel Achieves Ult. Str 70 ksi
 $M_{ult} = 30.2 \times \frac{70}{40} = 53 \text{ k-ft max.}$