

1. Report No. TX-01/2105-2		2. Government Accession No.		3. Recipient's Catalog No.	
4. Title and Subtitle GUIDELINES FOR BRIDGES OVER DEGRADING AND MIGRATING STREAMS. PART 1: SYNTHESIS OF EXISTING KNOWLEDGE				5. Report Date January 2001	
				6. Performing Organization Code	
7. Author(s) Jean-Louis Briaud, Hamn-Ching Chen, Billy Edge, Siyoung Park, and Adil Shah				8. Performing Organization Report No. Report 2105-2	
9. Performing Organization Name and Address Texas Transportation Institute The Texas A&M University System College Station, Texas 77843-3135				10. Work Unit No. (TRAIS)	
				11. Contract or Grant No. Project No. 7-2105	
12. Sponsoring Agency Name and Address Texas Department of Transportation Construction Division Research and Technology Transfer Section P. O. Box 5080 Austin Texas 78763-5080				13. Type of Report and Period Covered Research: Sept. 1999 – Aug. 2000	
				14. Sponsoring Agency Code	
15. Supplementary Notes Research performed in cooperation with the Texas Department of Transportation. Research Project Title: Develop Guidance for Design of New Bridges and Mitigation of Existing Sites in Severely Degrading and Migrating Streams					
16. Abstract This report is a collection of existing knowledge on the following topics: prediction of meander migration rate and stream bed degradation rate, and countermeasures for mitigating meander migration and stream bed degradation. Based on existing knowledge, two main conclusions were reached on the prediction of meander migration and stream bed degradation: <ol style="list-style-type: none"> 1. There is no reliable formula to predict these erosion movements. 2. The best existing way to predict such erosion movements is by extrapolation of historical data. Based also on existing knowledge, three main conclusions were drawn on the countermeasures for mitigating meander migration and stream bed degradation: <ol style="list-style-type: none"> 1. There are a large number of countermeasures to choose from. 2. There is no scientific basis for choosing the right countermeasure for a given case. 3. The best current practice is based on local experience and trial and error approach. 					
17. Key Words Meander Migration, Stream Bed Degradation, Bank Erosion, Rate of Movement Prediction, Countermeasures			18. Distribution Statement No Restrictions. This document is available to the public through NTIS: National Technical Information Service 5285 Port Royal Road Springfield, Virginia 22161		
19. Security Classif.(of this report) Unclassified		20. Security Classif.(of this page) Unclassified		21. No. of Pages 194	22. Price

GUIDELINES FOR BRIDGES OVER DEGRADING AND MIGRATING STREAMS. PART 1: SYNTHESIS OF EXISTING KNOWLEDGE

by

Jean-Louis Briaud
Research Engineer
Texas Transportation Institute

Hamn-Ching Chen
Associate Professor
Texas A&M University

Billy Edge
Professor
Texas A&M University

Siyoung Park and Adil Shah
Graduate Students
Texas A&M University

Report 2105-2
Project Number 0-2105

Research Project Title: Develop Guidance for Design of New Bridges and Mitigation of Existing
Sites in Severely Degrading and Migrating Streams

Sponsored by the
Texas Department of Transportation

January 2001

TEXAS TRANSPORTATION INSTITUTE
The Texas A&M University System
College Station, Texas 77843-3135

DISCLAIMER

The contents of this report reflect the views of the authors, who are responsible for the facts and accuracy of the data presented herein. The contents do not necessarily reflect the official views of policies of the Texas Department of Transportation (TxDOT). This report does not constitute a standard, specification, or regulation. In addition, the above assumes no liability for its contents or use thereof. The engineer in charge of the project was Dr. Jean-Louis Briaud, P.E. # 48690.

ACKNOWLEDGMENTS

This project was sponsored by the Texas Department of Transportation. The project director and chairman of the Project Monitoring Committee was Tom Dahl, who struck a very appreciated balance between listening to the researchers' concerns and maintaining the best interest of TxDOT. Mr. Dahl took a very active part in the research process and visited several of the case history sites. It was a pleasure to work with him. The program coordinator was Tony Schneider whose vision over the last six years has helped put TxDOT at the forefront of scour knowledge. He is succeeded by David Stolpa who has already helped the research team on several occasions. The RMC 3 staff engineer in the Construction Division Research, Technology, and Transfer Section was William Knowles.

The Project Monitoring Committee was composed of Rocky Armendariz, Robert Balfour, Kathy Dyer, Elston Eckhardt, Gerald Freytag, Donald Harley, Mark McClelland, and Wendy Worthey. We appreciate their support and their constructive criticisms. We also wish to extend special thanks to the TxDOT engineers who guided our five site visits: Kathy Dyer and Scott Shannon for the visit in the Paris District, Jerry Freytag for the visit in the Yokum district, Pat Williams and Terry Paholek of the Bryan District, John Kilgore of the San Antonio District, and Robert Balfour of the Beaumont District.

TABLE OF CONTENTS

LIST OF FIGURES	xiii
LIST OF TABLES	xviii
1. INTRODUCTION	1
1.1 What?	1
1.2 Why?	1
1.3 How?	1
1.4 Where, When, by Whom, and for Whom?	1
1.5 Organization of the Report	2
2. RIVER PATTERNS AND STABILITY	3
2.1 Channel Classification	3
2.2 Lane Relation	7
2.3 River Metamorphosis	8
3. MEANDER MIGRATION	11
3.1 Bank Erosion	11
3.2 Meander Growth and Shift	11
3.3 Cutoffs	12
3.4 Avulsion	13
4. DEGRADATION AND AGGRADATION	15
4.1 Aggradation	15
4.2 Backfilling and Downfilling	15
4.3 Nickpoint Migration	16
4.4 Degradation and Scour	16
5. RAPID CHANNEL STABILITY ASSESSMENT METHOD	19
5.1 Stream Reconnaissance and Field Inspection	19
5.2 Remote Sensing Techniques (Aerial Photographs)	19
6. PREDICTION OF MEANDER MIGRATION	21
6.1 Begin, Z.B., 1981, "Stream Curvature and Bank Erosion: A Model Based on the Momentum Equation."	21
6.2 Begin, A.B., 1986, "Curvature Ration and Ratio of River Bend Migration Update."	21
6.3 Brice, J. C., 1982, "Stream Channel Stability Assessment."	24
6.4 Chang, H. H., 1984, "Analysis of River Meanders."	26
6.5 Chang, T. P., Toebes, G. H., 1980, "Geometric Parameters for Alluvial Rivers Related to Regional Geology."	27
6.6 Chitale, S. V., 1980, "Shape and Mobility of River Meanders."	28
6.7 Comes, B. M., 1990, "Identification Techniques for Bank Erosion and Failure Processes."	29

TABLE OF CONTENTS (continued)

6.8	Diehl, T. H., and Bryan, B. A., 1993, “Supply of Large Woody Debris in a Stream Channel.”	30
6.9	Gilje, S. A., March 1979, “Debris Problems in the River Environment.”	30
6.10	Hagerty, D. J., Hamel J. V., 1989, “Geotechnical Aspects of River Bank Erosion.”	31
6.11	Harvey, M. D., 1989, “Meanderbelt Dynamics of the Sacramento River.”	31
6.12	Hasegawa, K., 1989, “Universal Bank Erosion Coefficient for Meandering Rivers.”	32
6.13	Herr, L. A., 1970, “The Control of Erosion and Sediment in Highway Construction.”	32
6.14	Hickin, E. J., 1977, “The Analysis of River-Planform Responses to Change in Discharge.”	33
6.15	Hickin, E. J., and Nanson, G. C., 1984, “Lateral Migration Rates of River Bends.”	33
6.16	Hooke, J. M., 1980, “Magnitude and Distribution of Rates of River Bank Erosion.”	34
6.17	Hudson, H. R., 1982, “A Field Technique to Directly Measure River Bank Erosion.”	35
6.18	Keady, D. M., Priest, M. S., 1977, “The Downstream Migration Rate of River Meandering Patterns.”	36
6.19	Lagasse, P.F., Schall, F. J., Richardson, E. V., 1999, “Stream Stability at Highway Structures.” Third edition.	37
6.20	Langbein, W. B., Leopold, L. B., 1966, “River Meanders – Theory of Minimum Variance.”	38
6.21	Levent, V., 1991, “Meander Bend Expansion and Meander Amplitude Development.”	38
6.22	Ligeng, L., Schiara, M., 1989, “Meander Bend Expansion and Meander Amplitude Development.”	40
6.23	Melville, B. W., Coleman, S. E., 1999, “Bridge Scour.”	45
6.24	Mosselman, E., Crosato, A., and Hasegawa, K., 1991, “Universal Bank Erosion Coefficient for Meandering Rivers.”	46
6.25	Nagabhushanaiah, H. S., 1967, “Meandering of Rivers.”	47
6.26	Nanson, G. C., Hickin, E. J., 1983, “Channel Migration and Incision on The Beatton River.”	48
6.27	Nanson, G. C., Hickin, E. J., 1986, “A Statistical Analysis of Bank Erosion and Channel Migration in Western Canada.”	49
6.28	Odgaard, A. J., 1987, “Streambank Erosion along Two Rivers in Iowa.”	49
6.29	Sidorchuk, A., Matveev, B., 1997, “Channel Processes and Erosion Rates in the Rivers of the Yamal Peninsula in Western Siberia.”	50
6.30	Thompson, P. L., 1990, “April 1989 Hatchie River US 51 Bridge Failure.”	51
6.31	Williams, G. P., 1986, “River Meanders and Channel Size.”	51

TABLE OF CONTENTS (continued)

7. PREDICTIONS OF STREAM BED DEGRADATION	57
7.1 Blench, T., 1969, "Mobile-Bed Fluviology."	57
7.2 Brice, J. C., 1982, "Stream Channel Stability Assessment."	57
7.3 Brice J. C., 1984, "Assessment of Channel Stability at Bridge Sites."	59
7.4 Brown, S. A., 1982, "Prediction of Channel Bed Grade Changes at Highway Stream Crossings."	60
7.5 Clifton, A. W., Krahn, J., Fredlund, D. G., 1981, "Riverbank Instability and Development Control in Saskatoon."	60
7.6 Franco, J. J., 1967, "Effects of Stages on Scour Along Riverbanks."	61
7.7 Gilje, S. A., 1982, "Stream Channel Grade Changes and Their Effects on Highway Stream Crossings."	61
7.8 Holly, F. M., Jr., Nakato, T., Kennedy, J. F., 1984, "Computer-Based Prediction of Alluvial Riverbed Changes."	62
7.9 Jain, S. C., Park, I., 1989, "Guide for Estimating Riverbed Degradation."	63
7.10 Johnson, P.A., Simon, A., 1995, "Reliability of Bridge Foundations in Unstable Alluvial Channels."	63
7.11 Lacey, G., 1930, "Stable Channels in Alluvium."	64
7.12 Lagasse, P. F., Schall, F. J., Richardson, E. V., 1999, "Stream Stability at Highway Structures."	64
7.13 Lane, E. W., 1957, "A Study of the Shape of Channels Formed by Natural Streams Flowing in Erodible Materials."	68
7.14 Monk, W. C., 1995, "July 1993 Flood Damage to US 71 Bridge Over Bushy Creek, Carroll County, Iowa: Case Study."	68
7.15 Odgaard, A. J., Spoljaric, A., 1989, "Sediment Control by Submerged Vanes, Design Basis."	68
7.16 Odgaard, A. J., Wang, Y., 1990, "Sediment Management with Submerged Vanes."	69
7.17 Richard, P., George T., 1999, "CAESAR: An Expert System for Evaluation of Scour and Stream Stability."	69
7.18 Rus, David L., Soenksen, Philip J., 1998, "Channel Stability of Turkey Creek, Nebraska."	69
7.19 Schall, J. D., Lagasse, P. E., 1991, "Stepwise Procedure for Evaluating Stream Stability."	70
7.20 Sherrill, J., Kelly, S., 1992, "Using Scour and Stream Instability Evaluations to Increase Bridge Safety."	71
7.21 Soni, J. P., Kumar, N., 1980, "Evaluation of Friction Factor in Aggrading and Degrading Alluvial Channels."	72
7.22 Trent, R. E., Brown, S. A., 1984, "An Overview of Factors Affecting River Stability."	73
7.23 Weber, L. L., 1996, "Channel Scour Protection at Roadway Crossings."	73
7.24 Yang, X., Mcvey, M. J., Morris, L. L., Baumel, C. P., 1995, "Impact of Stream Degradation on Bridges and Rural Travel Patterns."	73

TABLE OF CONTENTS (continued)

8. COUNTERMEASURES	75
8.1 Introduction.....	75
8.2 Countermeasures Classification.....	76
8.3 Revetments.....	76
8.3.1 Flexible Revetments	77
8.3.1.1 Riprap.....	77
8.3.1.2 Wire Enclosed Riprap.....	78
8.3.1.3 Articulated Concrete Block System.....	78
8.3.1.4 Concrete Armor Units.....	80
8.3.1.5 Grout/Cement Filled Bags	80
8.3.1.6 Rock Riprap at Pier and Abutment	80
8.3.1.7 Used Tire Revetment	81
8.3.1.8 Vegetation.....	81
8.3.1.9 Rock-Fill Trenches	82
8.3.1.10 Windrow Revetment	82
8.3.2 Rigid Revetments.....	84
8.3.2.1 Articulated Grout-Filled Mattress.....	84
8.3.2.2 Soil Cement.....	85
8.3.2.3 Concrete Pavement	87
8.3.2.4 Sacked Concrete/Sacks	87
8.4 Flow Control Structures.....	87
8.4.1 Check Dams/Drop Structures	87
8.4.2 Spurs	89
8.4.3 Permeable Spurs	91
8.4.4 Retards	91
8.4.4.1 Jacks and Tetrahedrons.....	92
8.4.4.2 Fence Retards.....	93
8.4.4.3 Timber Piles.....	93
8.4.4.4 Wood Fences.....	93
8.4.5 Dikes	94
8.4.5.1 Longitudinal Dikes	94
8.4.5.2 Earth or Rock Dikes.....	94
8.4.5.3 Crib Dikes	94
8.4.5.4 Rock-Toe Dikes	95
8.4.6 Guidebanks or Spur Dikes	95
8.4.7 Bendway Weirs.....	96
8.4.8 Hard Points	98
8.5 Bulkheads.....	98
8.6 Channel Relocation.....	99
8.7 Published Case Histories in Texas.....	100
8.7.1 East Fork Trinity River at Atchison, Topeka, and Santa Fe Railway Bridge Near Lavon, Texas.....	100
8.7.2 Trinity River at FM 162 near Moss Hill, Texas.....	100
8.7.3 Brazos River at FM 1462 near Rosharon, Texas	100

TABLE OF CONTENTS (continued)

8.7.4 Cold Creek at SR 71 near Pontotoc, Texas.....	100
8.7.5 Colorado River at U.S. 90 at Columbus, Texas.....	101
8.7.6 Gills Branch at SR 21 at Bastrop, Texas	101
8.7.7 Atascosa River at FM 99 near Whitsett, Texas.....	101
8.7.8 Tunis Creek at I-10 near Bakersfield, Texas	101
8.7.9 Brazos River at FM 529 near Bellville, Texas.....	102
8.7.10 Overflow Channel, Nueces, and Frio Rivers at U.S.281 near Three Rivers, Texas	102
8.7.11 Merrill Creek at FM 1550 near Ladonia, Texas	102
8.7.12 Sabine Pass at Louisiana SR 82 near Port Arthur, Texas	102
8.7.13 Mountain Creek at Dallas-Ft. Worth Turnpike, Texas	102
8.7.14 Brazos River at Pipeline Crossing near U.S. 90A, near Houston, Texas	103
8.8 Excerpts from Other References.....	103
8.8.1 Abam, T.K.S., Okagbue, C.O., 1986, “Construction and Performance of Riverbank Erosion Protection Structure in the Niger Delta.”	103
8.8.2 Abam, T.K.S., 1993 “Control of Channel Bank Erosion Using Permeable Groins.”	103
8.8.3 Brice, J. C., Blodgett, J. C., 1978, “Countermeasures for Hydraulic Problems at Bridges.”	104
8.8.4 Brown, S. A., Mcquivey, R. S., Keefer, T. N., March 1981, “Stream Channel Degradation and Aggradation: Analysis of Impacts to Highway Crossings.”	104
8.8.5 Brown, S. A., 1985, “Streambank Stabilization Measures for Highway Stream Crossings Executive Summary.”	106
8.8.6 Hanson, G. J., Lohnes, R. A., Klaiber, F. W., 1986, “Gabions Used in Stream-Grade-stabilization Structures: A Case History.”	109
8.8.7 Lafayette, R. A., Pawelek, D. W. 1989, “New Revetment Design Controls Streambank Erosion.”	110
8.8.8 Michiue, M., Hinokidani, O., Suzuki, K., 1989, “Simulation and Countermeasure Against Bed Degradation and Aggradation in River Channel.”	110
8.8.9 Pagan-Ortiz J. E., “Stability of Rock Riprap for Protection at Toe of Abutments at Flood Plain.”	110
8.8.10 Richardson, E. V., Simons, D. B., 1984, “Use of Spurs and Guidebanks for Highway Crossings.”	111
8.8.11 Shen, H. W., Wang, S. Y., 1984, “Analysis of Commonly Used Riprap Design Based on Extended Shields Diagram.”	111
8.8.12 Stevens, M. A, Simons, D. B., Richardson, E. V., 1984, “Riprap Stability Analysis.”	112
9. RESULTS OF SURVEY	113
9.1 Introduction.....	113
9.2 Analysis of the Responses	113
9.3 Ongoing Research Projects	117

TABLE OF CONTENTS (continued)

9.4 Findings	117
10. ECONOMIC RISK ANALYSIS	121
10.1 Risk Analysis	121
10.2 Alternative Analysis Methods	122
11. CASE HISTORIES	127
11.1 SH 105 Bridge over the Brazos River Bryan District	127
11.1.1 Location, River, and Bridge Description	128
11.1.2 Hydrograph	128
11.1.3 Soil Type	128
11.1.4 History of the Problem	128
11.1.5 Countermeasures	131
11.2 U.S. 90 Westbound Main Lane Bridge over the Nueces River, San Antonio District	134
11.2.1 Location	134
11.2.2 Bridge and River Description	134
11.2.3 Hydrograph	136
11.2.4 History of the Problem	136
11.2.5 Countermeasures	138
11.3 Trinity River – Beaumont	141
11.3.1 Location	141
11.3.2 Bridge and River Description	142
11.3.3 History of the Problem	142
11.3.4 Countermeasures	143
11.3.5 Soil Type	144
11.4 Streambed Degradation of the North Sulfur River	145
11.4.1 The North Sulfur River	145
11.4.2 History of the Problem	145
11.4.3 Sites Visited	145
11.4.4 Erosion of Clay Shale	149
11.4.5 Countermeasures	149
11.5 Meander Migration on the Guadalupe River	155
11.5.1 The Guadalupe River	155
11.5.2 The U.S. 59 at Guadalupe River Bridge	155
11.5.3 The SH 80 at Guadalupe River Bridge	158
12. CONCLUSION AND RECOMMENDATIONS FOR FURTHER RESEARCH	163
12.1 Conclusions	163
12.2 Recommendations for Future Research	164
12.3 Action Plan	166
13. REFERENCES	169

LIST OF FIGURES

Figure 2.1	Channel Pattern Classification Devised by Brice (Brice 1975)	4
Figure 2.2	Stream Properties for Classification and Stability Assessment (Brice 1978)	5
Figure 2.3	Channel Classification Showing Stability and Types of Hazards Encountered with Each Pattern (Shen et al. 1981)	6
Figure 2.4	The Interrelation between Stream Form and Slope (Richardson et al. 1990).....	7
Figure 2.5	Interrelation between Stream Form, Channel Bed Slope and Mean Discharge (after Lane 1957)	8
Figure 3.1	Modes of Meander Loop Behavior (Brice 1977)	12
Figure 6.1	Correlation between Theoretically Derived C and Measurement of Bend Migration Rate M (Begin 1986).....	23
Figure 6.2	Relationship between Stream Curvature R/w, Rate of Bend Migration M in m/yr, and Coefficient C (Begin 1986).....	24
Figure 6.3	Median Bank Erosion Rate in Relation to Channel Width for Different Types of Streams (Brice 1982)	25
Figure 6.4	Erosion Index in Relation to Sinuosity for Different Types of Streams (Brice 1982)	26
Figure 6.5	Relation of Maximum Curvature with Slope, Discharge, Sediment Size, and Width-Depth Ratio (Chang 1984).....	27
Figure 6.6	Relationship between Erosion Rates and Catchment Area (Hooke 1980)	35
Figure 6.7	Graph for Determining Rate of Meander Migration (Keady 1977)	37
Figure 6.8	Definition Sketch for a Meander (Levent 1991)	39
Figure 6.9	The Movement of a Meander Bend (Levent 1991).....	39
Figure 6.10	Definition of the Expansion Rate (dy/dt) (Ligeng 1989)	40

LIST OF FIGURES (continued)

Figure 6.11	Flow Velocities and Shear Stress Close to the Wall at a Concave River Bank (Ligeng 1989)	41
Figure 6.12	Geometric Relationships of a Meander Bend (Ligeng 1989).....	43
Figure 6.13	Definition Sketch of a Meandering River (Nagabhushanaiah 1967)	48
Figure 6.14	The Relation between Relative Migration Rates (after Nanson and Hickin 1983, 1986).....	49
Figure 6.15	Plan-View Sketch of Idealized River Meanders (Williams 1986)	52
Figure 6.16	Observed Values of Bend Radius of Curvature versus Predicted by the Equation of Langbein and Leopold (1966).....	53
Figure 6.17	Frequency Distribution of R_c/W values for 79 Streams (Williams 1986)	53
Figure 6.18	Meander Bend Radius of Curvature, in Meters (Williams, 1986)	54
Figure 8.1	Design Figures for Wire Enclosed Riprap (NMSHTD).....	79
Figure 8.2	Used Tire Riprap	81
Figure 8.3	Rock-Fill Trench	82
Figure 8.4	Windrow Revetment.....	83
Figure 8.5	Articulated Concrete Bags.....	85
Figure 8.6	Soil Cement Cross-Section (Stair-Step Method).....	85
Figure 8.7	Soil Cement	86
Figure 8.8	Check Dam	88
Figure 8.9	Stilling Basin	89
Figure 8.10	Spur	90
Figure 8.11	Spur Field	91

LIST OF FIGURES (continued)

Figure 8.12	Jack Field.....	92
Figure 8.13	Tetrahedrons.....	92
Figure 8.14	Timber Pile Retards.....	93
Figure 8.15	Timber Crib Dike	94
Figure 8.16	Rock-Toe Dike	95
Figure 8.17	Guidebank or Spur Dikes	96
Figure 8.18	Bendway Weir Typical Cross-Section	97
Figure 8.19	Bendway Weir Typical Plan View	97
Figure 8.20	Hard Point.....	98
Figure 8.21	Bulkhead.....	99
Figure 8.22	Channel Relocation	99
Figure 8.23	Risk and Difficulty versus Complexity	105
Figure 9.1	Sample Letter Written to DOT and FHWA Engineers	114
Figure 10.1	Generic Decision Tree.....	123
Figure 10.2	Application of Countermeasures against Erosion Caused by Stream Migration	124
Figure 11.1	1988 Aerial Photo of the Site	127
Figure 11.2	Channel Migration between 1969 and 1999.....	129
Figure 11.3	Sketch of Channel Migration	130
Figure 11.4	Pier No. 50 on the West Bank of the Brazos River.....	131
Figure 11.5	Site Photos.....	132
Figure 11.5	Site Photos (Continued).....	133

LIST OF FIGURES (continued)

Figure 11.6	U.S. 90 Bridge and Relief Structure at the Nueces River	134
Figure 11.7	1960 Topography of the Nueces River.....	135
Figure 11.8	U.S. 90 Bridge at the Nueces River-Looking Northwest	137
Figure 11.9	Nueces River North of U.S. 90 Bridge (Relief on Right side)—140 Looking South.....	138
Figure 11.10	1998 Flood.....	139
Figure 11.11	Nueces River South of U.S. 90 Bridge—Looking North.....	140
Figure 11.12	Trinity River at Highway 787	141
Figure 11.13	Failure of the Sheet Pole Wall at a Countermeasure	142
Figure 11.14	Erconet Palisades as Countermeasures.....	143
Figure 11.15	Riprap as a Countermeasure.....	144
Figure 11.16	Exposed Piers on the North Sulfur River	146
Figure 11.17	Erosion of Abutment on the North Sulfur River	147
Figure 11.18	FM 904 at North Sulfur River Bridge	148
Figure 11.19	FM 2990 at North Sulfur River Bridge	150
Figure 11.20	SH 34 at North Sulfur River Bridge.....	151
Figure 11.21	Erosion of Clay Shale.....	152
Figure 11.22	Guardrail Wall for Abutment Protection.....	153
Figure 11.23	Guardrail Wall and Grouted Embankment.....	153
Figure 11.24	Use of Gabions and Concrete Surfacing for Erosion Protection.....	154
Figure 11.25	U.S. 59 at Guadalupe River Bridge (South Bound)	156
Figure 11.26	Bank Erosion near U.S. 59 at Guadalupe River Bridge	157

LIST OF FIGURES (continued)

Figure 11.27 SH 80 at Guadalupe River Bridge159

Figure 11.28 Channel Migration at SH 80 at Guadalupe River Bridge.....160

Figure 11.29 Bank of Meander before Installation of Ercon Nets.....160

Figure 11.30 Bank of Meander after Installation of Ercon Nets.....161

LIST OF TABLES

Table 6.1	Data on Bend Curvature and Rate of Bend Migration for Beaton River, Canada	23
Table 6.2	Data Used in the Analysis.....	36
Table 6.3	Derived Equations for River-Meander and Channel Size Features.....	55
Table 7.1	The Lacey “Silt Factor” f as a Function of Grain for Cohesionless Sediment	64
Table 9.1	States Who Responded	113
Table 9.2	Numbers of Responses	115
Table 9.3	Summary of Responses.....	116
Table 9.4	Guidance Documents Mentioned by the Respondents	118
Table 9.5	Web Sites Searched	118

1. INTRODUCTION

1.1 WHAT?

This report is the result of phase one of a project sponsored by the Texas Department of Transportation to develop guidance for the design of new bridges and mitigation of existing sites in severely degrading and migrating streams. Phase one of this project consisted of collecting existing information on the topic. Note that this topic includes the prediction of meander migration and streambed degradation as well as the selection and design of countermeasures. This is indeed a very broad topic.

1.2 WHY?

Migrating and degrading streams represent a major problem for the safety of bridges, and therefore the public, in Texas. Bridges over rivers are typically designed and built for a life of 75 years. During these 75 years the unforeseen behavior of the river may require river training measures or modification of the bridge or both. These measures can cost from \$100,000 to \$3,000,000 per bridge. Considering that Texas has about 40,000 bridges (including bridge class culverts) with some 85 percent of them over water, the cost of migrating and degrading streams to TxDOT is very significant. There is an urgent need to improve the current approach to meander migration and streambed degradation in a continued effort by TxDOT to ensure public safety and optimize cost.

1.3 HOW?

The review of existing knowledge on the topic of meander migration and streambed degradation was achieved by performing a library survey of the published literature, a letter survey of the state transportation, and the visit of six sites in Texas where such problems exist. The literature search yielded 192 useful references. From those 192 references, 106 were actually obtained and read. From the 106 references read, 63 were summarized and are included in this report. The topic of the 63 references can be broken down into general stream instability (13), meander migration and bank erosion (21), degradation and aggradation (14), and countermeasure (15). The survey letter was sent to all geotechnical and hydraulic engineers in DOTs. A total of 52 responses from 30 states were received with 11 different answers, which were particularly useful. Six problem sites in Texas were visited to get a better appreciation of the nature and the magnitude of the problem as well as to receive some direct input from the DOT engineers who face this problem on a regular basis.

1.4 WHERE, WHEN, BY WHOM, AND FOR WHOM?

Researchers performed phase one of this project at the Texas Transportation Institute on the campus of Texas A&M University. This phase started on September 1, 1999, and ended on August 31, 2000. The students involved were Siyoung Park, who looked after the literature survey, and Adil Shah who looked after the letter survey. The faculty members involved were

H.C. Chen, Billy Edge, and Jean-Louis Briaud. They visited the sites, prepared summaries of their visits, and oversaw the project through weekly meetings with the students. The sponsor was the Texas Department of Transportation where Tom Dahl was the Project Director, Tony Schneider the Program Coordinator, and William Knowles the Construction Division Research Engineer. The Project Monitoring Committee was chaired by Tom Dahl and composed of David Stolpa, Donald Harley, Elston Eckhardt, Rocky Armendiz, Gerald Freytag, Robert Balfour, Mark McClelland, Kathy Dyer, and Wendy Worthey.

1.5 ORGANIZATION OF THE REPORT

Sections 2 to 4 are reviews of definitions and fundamental aspects of river behavior including meander migration and streambed degradation. Sections 5 to 7 deal with published prediction methods for meander migration and streambed degradation. Section 8 is dedicated to countermeasures. Section 9 is a summary of the responses to the letter survey. Section 10 deals with economic and risk analysis. Case histories are covered in Section 11 followed by [conclusions and recommendations](#) for further research.

2. RIVER PATTERNS AND STABILITY

Rapid and otherwise unexpected river changes may occur in response to natural or man-made disturbances of the fluvial system. It is important to the highway engineer to be able to predict changes in channel morphology, location, and behavior. To a large extent the relative stability of a channel is revealed by its patterns. Therefore, in this chapter a discussion of channel patterns provides background information for a discussion of river behavior and hazards. This content is based on a book titled *Methods for Assessment of Stream-Related Hazards of Highways and Bridges* (Shen et al.1981).

2.1 CHANNEL CLASSIFICATION

Alluvial channels are dynamic and subject to change, but changes are of different types, and rates of change are highly variable. Alluvial channel movements are the cumulative result of a combination of climatic, geological, topographic, hydrologic, and human disturbance factors. Basically, there are three types of channel patterns: straight, meandering, and braided. Rivers with different patterns behave differently, and their other morphologic characteristics are different. Therefore, pattern identification should be the first step toward evaluation of river stability and the identification of potential river hazards.

Brice (1975) developed a descriptive classification of alluvial rivers that provides an excellent summary of channel patterns. The channel properties that Brice selected as being important for classification are the degree of sinuosity, braiding and anabranching, and the character of meandering, braided, and anabranching streams (Figure 2.1)

Brice and Blodgett (1978) classified streams according to Figure 2.2, which is based on stream properties observable on aerial photographs and in the field. The major purpose of Figure 2.2 is to facilitate the assessment of streams for engineering purposes, with particular regard to lateral stability. Aggradation and degradation are difficult to assess from the physical appearance of a stream, although they are important aspects of river behavior for engineering purposes. Each of the 14 properties listed in the left column of Figure 2.2 could be used as the basis of valid stream classification and stream stability. For example, classification as alluvial or non-alluvial is useful for some limited purposes and alluvial streams, in general, are susceptible to more hydraulic problems than non-alluvial streams.

In Figure 2.2, Sinuosity is the ratio of channel length to valley length or the ratio of thalweg length to the valley length. A channel with sinuosity less than 1.05 is straight, one with sinuosity between 1.05 and 1.25 is sinuous, and one with a sinuosity greater than 1.25 is a meandering channel. There is little relation between degree of sinuosity and lateral stability. A highly meandering stream may have a lower rate of lateral migration than a sinuous stream of similar size according to Figure 2.1. Stability is largely dependent on other properties, especially bar development and the variability of channel width.





























Degree of Sinuosity	Degree of Braiding	Degree of Anabranching
 1 1-1.05	 0 <5%	 0 <5%
 2 1.06-1.25	 1 5-34%	 1 5-34%
 3 >1.26	 2 35-65%	 2 35-65%
 3 >65%	 3 >65%	 3 >65%
Character of Sinuosity	Character of Braiding	Character of Anabranching
 A Single Phase, Equiwidth Channel, Deep	 A Mostly Bars	 A Sinuous Side Channels Mainly
 B Single Phase, Equiwidth Channel	 B Bars and Islands	 B Cutoff Loops Mainly
 C Single Phase, Wider at Bends, Chutes Rare	 C Mostly Islands, Diverse Shape	 C Split Channels, Sinuous Anabranches
 D Single Phase, Wider at Bends, Chutes Common	 D Mostly Islands, Long and Narrow	 D Split Channel, Sub-parallel Anabranches
 E Single Phase, Irregular Width Variation		 E Composite
 F Two Phase Underfit, Low-water Sinuosity		
 G Two Phase, Bimodal Bankfull Sinuosity		

Figure 2.1. Channel Pattern Classification Devised by Brice (Brice 1975).






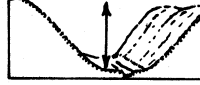




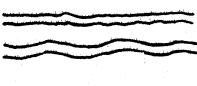



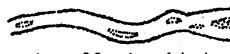


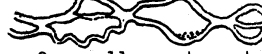
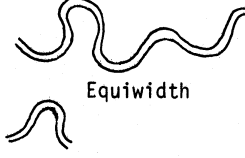
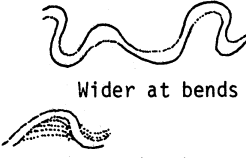
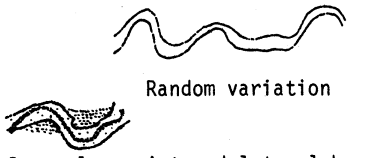
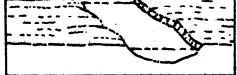

CHANNEL WIDTH	Small (<100 ft or 30 m wide)	Medium (100-500 ft or 30-150 m)	Wide (>500 ft or 150 m)		
FLOW HABIT	Ephemeral (Intermittent)	Perennial but flashy	Perennial		
CHANNEL BOUNDARIES	 Alluvial	 Semi-alluvial	 Non-alluvial		
BED MATERIAL	Silt-clay	Silt	Sand	Gravel	Cobble or boulder
VALLEY; OR OTHER SETTING	 Low relief valley (<100 ft or 30 m deep)	 Moderate relief (100-1000 ft or 30-300 m)	 High relief (>1000 ft or 300 m)	 No valley; alluvial fan	
FLOOD PLAIN	 Little or none ($<2x$ channel width)	 Narrow ($2-10x$ channel width)	 Wide ($>10x$ channel width)		
DEGREE OF SINUOSITY	 Straight (Sinuosity 1-1.05)	 Sinuous (1.06-1.25)	 Meandering (1.26-2.0)	 Highly meandering (>2)	
DEGREE OF BRAIDING	Not braided (<5 percent)		 Locally braided (5-35 percent)	 Generally braided (>35 percent)	
DEGREE OF ANABRANCHING	Not anabranching (<5 percent)		 Locally anabranching (5-35 percent)	 Generally anabranching (>35 percent)	
VARIABILITY OF WIDTH AND DEVELOPMENT OF BARS	 Equiwidth Narrow point bars	 Wider at bends Wide point bars	 Random variation Irregular point and lateral bars		
APPARENT INCISION	 Not incised		 Probably incised		
CUT BANKS	Rare	Local	General		
BANK MATERIAL	Coherent Resistant bedrock Non-resistant bedrock Alluvium			Non-coherent Silt; sand gravel; cobble; boulder	
TREE COVER ON BANKS	<50 percent of bankline	50-90 percent	>90 percent		

Figure 2.2. Stream Properties for Classification and Stability Assessment (Brice 1978).

Shen et al. (1981) present five basic patterns (Figure 2.3) that will aid the highway engineer in establishing the relative stability of the channel and in identifying some hazards that affect bridge stability. Figure 2.3 is more meaningful than a purely descriptive classification of channels because it is based on cause and effect relations, and it illustrates the differences to be expected when the type of sediment load, flow velocity and stream power differ among rivers.

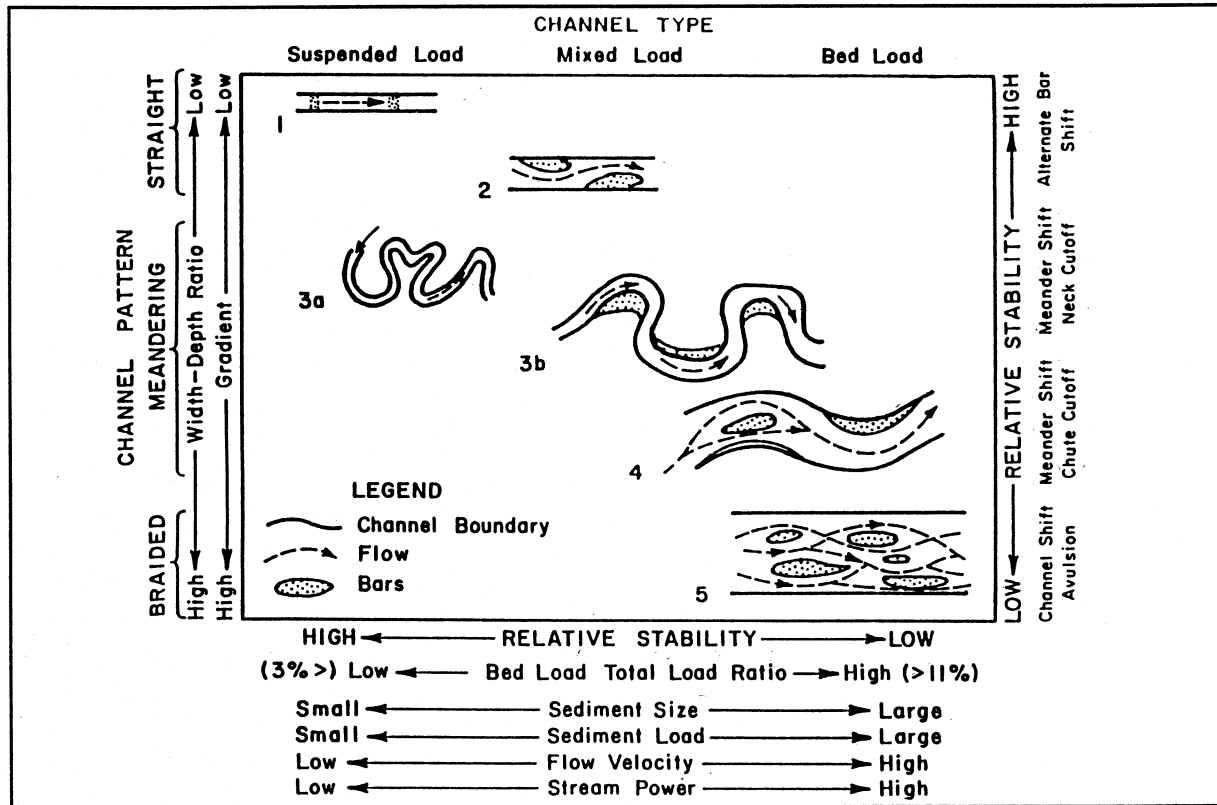


Figure 2.3. Channel Classification Showing Stability and Types of Hazards Encountered with Each Pattern (Shen et al. 1981).

In Figure 2.3 there is a difference between sediment load, bed load, and total load:

- sediment load: amount of sediment being moved by a stream;
- bed load: sediment that is transported by rolling, sliding, or skipping along the bed or very close to it; considered to be within the bed layer; and
- total load: the sum of suspended load and bed load.

A classification of alluvial channels should be based not only on channel patterns but also on the variables that influence channel morphology. This is particularly true if the classification is to provide information on channel stability. Numerous empirical relations indicate that channel dimensions are due largely to water discharge, whereas channel shapes and patterns are related to the type and amount of sediment load moved through the channel. One would also think that the soil type of the riverbed would have a significant influence, yet this factor is not acknowledged in the figure.

2.2 LANE RELATION

The interrelation between stream form and slope is illustrated schematically in Fig. 2.4. From this figure, it can be seen that a given variation in slope can markedly modify the stream pattern.

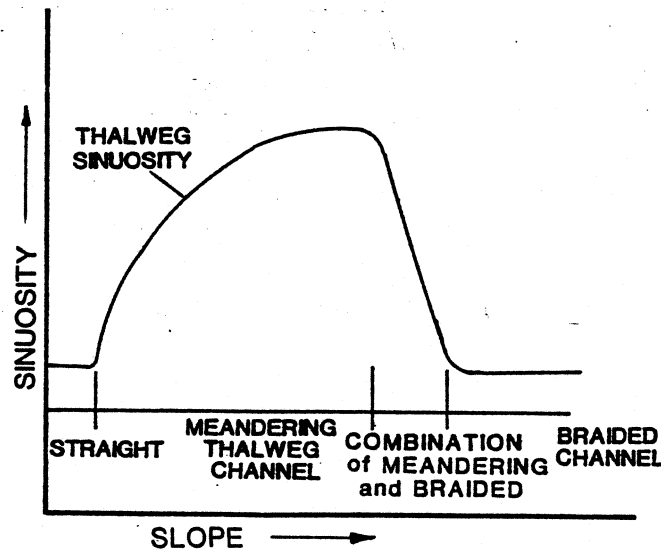


Figure 2.4. Interrelation between Stream Form and Slope (Richardson et al. 1990).

Quantitative relations between stream form, channel bed slope S_0 , and mean discharge Q are presented by Lane (1957), and the relations are shown in Figure 2.5.

A sandbed is predicted to meander for $S_0 Q^{0.25} \leq 0.00070$ and a sandbed is further predicted to be braided for $S_0 Q^{0.25} \geq 0.0041$. A transition zone is indicated to occur between these two relations. In this zone, a stream is indicated to be able to change rapidly from one stream form to the other depending on changing conditions. Based on data for a variety of natural streams, Leopold and Wolman (1960) determined that for meandering streams $S_0 Q^{0.44} \leq 0.0125$ and for braided streams $S_0 Q^{0.44} \geq 0.0125$

The relations of Figure 2.5 provide an assessment of stream nature that can be used in conjunction with earlier indicators of stability in an essentially qualitative assessment of potential stream stability.

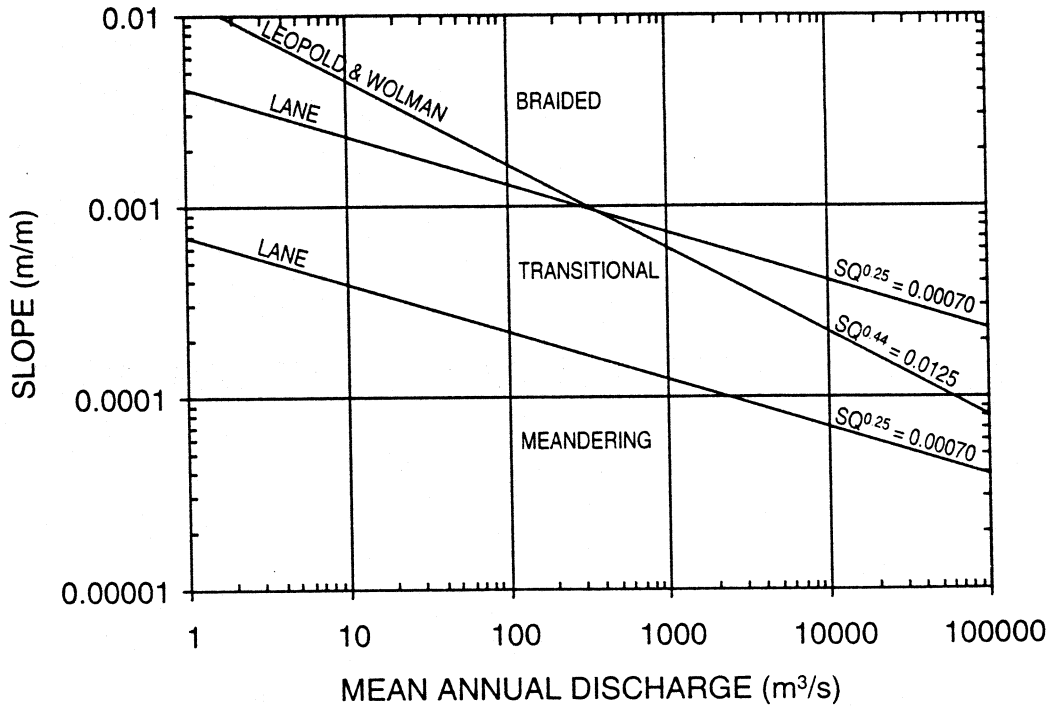


Figure 2.5. Interrelation between Stream Form, Channel Bed Slope, and Mean Discharge (after Lane 1957).

2.3 RIVER METAMORPHOSIS

River metamorphosis refers to significant changes not only in the dimensions of the river cross-section, but in its longitudinal pattern and shape. It is possible to consider six types of river metamorphosis as follows: a straight channel changes to meandering or braided, a braided channel changes to meandering or straight, and a meandering channel changes to straight or braided (Shen et al. 1980).

There is some similarity in the hazards posed by some types of metamorphosis, and they can be discussed as three pairs.

- a) Straight and meandering to braided: Both the straight and the meandering channels will widen and, of course, the meandering will straighten and become steeper. The hazards associated with this type of metamorphosis are bank erosion, cutoffs, and bar and island formation. If the change is the result of increased sediment load, aggradation will be important, but the increased gradient of the straightened meandering channel will lead to the degradation and bank erosion. The metamorphosis involves a dramatic and destructive alteration of the former channel and sometimes destruction of much of the former flood plain. Existing bridges will be too short and their approaches will be destroyed as the channel changes.

- b) Straight and braided to meandering: a straight channel may develop alternate bars and a sinuous thalweg if there is an increase of sediment load. If the straight channel begins to meander, bridges crossing the straight channel will be subjected to meander growth, shift, cutoff, and avulsion when the metamorphosis takes place. In the case of a metamorphosis from braided to meandering, the change may actually result in increased channel stability. The decreased gradient will reduce the erosional forces acting on the channel, and although the development of meanders is a hazard in itself, they will form in the old channel, and existing bridges may appear too long for the new narrow sinuous channel.
- c) Meandering and braided to straight: a bar-braided channel can become island-braided when the bars are colonized by vegetation, and then the islands can be incorporated into a new flood plain. The narrowed channel should degrade, but not appreciably. The narrower channel will probably represent a more stable condition, although the increased presence of vegetation may raise the stage of large floods, which could damage a bridge. The conversion of a meandering channel to a straight channel will be the result of a series of natural cutoffs. The steepened gradient will cause bank erosion and perhaps degradation. Unless there have been hydraulic changes, the channel will attempt to meander and will be very unstable. This is especially true when the channel has been straightened artificially.

3. MEANDER MIGRATION

In this chapter, hazards contributing to meander migration are presented and those are described in three ways; (1) definition of hazards which are caused by any factor that may adversely affect the geomorphic, hydrologic, and hydraulic conditions of a stream at a bridge site, (2) consequences of hazards that pose danger to the highway crossing, and (3) identification of hazards and assessment of their potential effect on a bridge site. The researches based these contents on the book titled *Methods for Assessment of Stream-Related Hazards of Highways and Bridges* (Shen et al.1981).

3.1 BANK EROSION

Bank erosion is the removal of bank materials by either a grain-by-grain removal or by mass movement (slumping or toppling). Mass failure of the bank can be the result of undercutting the toe of the bank, steepening of the slope, surcharging the bank by constriction or dumping, or by seepage forces and pore water pressures related to increased water movement through bank sediment.

The effect of bank erosion is a shift in the bank line of the river and the introduction of additional sediment into the channel. Erosion of both banks widens the channel, and it may lead to aggradation. According to a survey of various state highway engineers (Brice and Blodgett 1978), bank erosion is rated as a major stream-related hazard.

Bank erosion is easy to recognize. Color infrared aerial photography is useful. Although active bank erosion is readily identified, it may be only part of a larger problem, and it may be symptomatic of other hazards that are related to channel shift or metamorphosis. The rate of bank retreat can be estimated by comparing large-scale multi-date photography. Sequential aerial photography is an excellent tool for recording long-term trends in bank changes (Brice 1971). Recent studies show that color infrared photography generally is superior for species identification, plant vigor measurements, and vegetation mapping (Jones 1977), and these images may be useful in identifying bankline vegetation that is stressed by root exposure and bank failure.

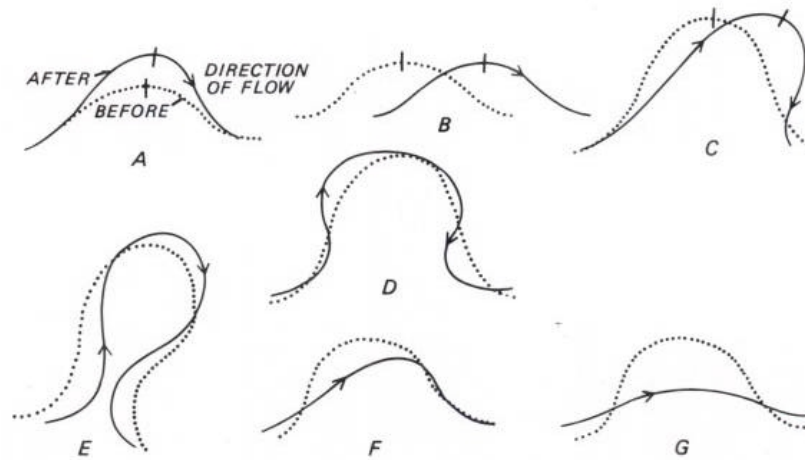
3.2 MEANDER GROWTH AND SHIFT

Meander growth involves a change in the dimensions of a meander. Meander amplitude and width increase as a meander enlarges. At the same time the radius of curvature of the bend will increase. Meander shift involves the displacement of the meander in a downstream direction. Usually the meander both grows and shifts downstream, although some parts of the bend can actually shift upstream. Figure 3.1 presents the various modes of meander loop behavior.

Meander growth and shift not only cause bank erosion at the crest and on the downstream side of the limbs of a meander, but it also changes the flow alignment. Increased meander amplitude results in a local reduction in channel slope with possible aggradation in the bend. All of these factors represent hazards to a bridge. Meander growth and shift will be of greatest significance

where discharge is great, bank sediments are weak, and bank vegetation is negligible due to aridity or to agricultural practices.

Lateral and downvalley movement of meander bends is a characteristic feature of alluvial rivers and one of the most conspicuous changes affecting fluvial landscapes (Gregory 1977). In order to determine the relative stability of the bend, a historical investigation using maps and aerial photographs is needed. If investigators can obtain clear evidence of meander shift, they can estimate future channel change. Obviously, if the shifting meander encounters bedrock or more resistant alluvium, the rate of shift will decrease. Therefore, a soils and geologic investigation of the site should be made to determine the variability of the resistance of the bank material.



A. Extension, B. Translation, C. Rotation, D. Conversion to a Compound loop, E. Neck Cutoff by Closure, F. Diagonal Cutoff by Chute, G. Neck Cutoff by Chute

Figure 3.1. Modes of Meander Loop Behavior (Brice 1977).

3.3 CUTOFFS

A cutoff is a new and relatively short channel formed across the neck of a meander bend. This drastically reduces the length of the stream in that reach and significantly steepens its gradient. The neck cutoff has the greatest effects on the channel. Another type of cutoff is the chute cutoff, which forms by cutting across a portion of the point bar. The chute cutoff generally forms in recently deposited alluvium, whereas the neck cutoff forms both in recent alluvium and in older consolidated alluvium or even in weak bedrock.

The consequence of cutoffs of both types is that the river is steepened abruptly at the point of the cutoff. This can lead to scour at that location and a propagation of the scour in an upstream direction. If a bridge is located upstream from the cutoff, the results are similar to those described for degradation and nickpoint migration.

In the downstream direction, the gradient of the channel is not changed below the site of the cutoff, and therefore the increased sediment load caused by upstream scour will usually be

deposited at the site of the cutoff or below it, forming a large bar. Downstream from the cutoff a bridge will be affected by aggradation, downfilling, and bar formation.

It is very easy to identify where a meander has been cut off. However, the problem is not so much to identify where a cutoff has occurred, but where it will occur. Generally, this can be done by examining a sequence of aerial photographs to determine the rate at which bank erosion is decreasing the width of the meander neck. In addition, if through time an increase in the amplitude of a bend or the sinuosity of a reach can be noted, then that bend or reach may be susceptible to a cutoff, because the increasing length of the channel is accompanied by a decrease of gradient and the ability of the channel to transport its sediment load.

3.4 AVULSION

Avulsion is the abrupt change of the course of a river. A channel is abandoned and a new one formed as the water and sediment take a new course across the flood plain, alluvial fan, or alluvial plain. A meander cutoff is a type of avulsion because of relatively rapid change in the course of a river during a short period of time, but avulsion, as defined here, involves a major change of channel position below the point of avulsion.

A new channel forms below the point of avulsion. If the channel avulses into an existing, smaller channel, a large increase in discharge and sediment load will result, and the bridges downstream of this channel will be inadequate and presumably destroyed. A bridge on the abandoned channel below the site of avulsion will appear to be significantly oversized. If, through avulsion, the river takes a shorter course to the sea, the gradient will become steeper, and scour above the point of avulsion is certain unless a bedrock control prevents upstream degradation. A bridge located above the point of avulsion will still span the channel, but it may be subjected to degradation and nickpoint migration.

It is an easy matter to identify where avulsion has or is taking place. The problem is identification of a site of potential avulsion so that this can be prevented or steps can be taken to mitigate the effects of avulsion when it occurs. In a progressively aggrading situation as on an alluvial fan, the stream will build itself out of its channel and be very susceptible to avulsion. In other words, in a cross profile on an alluvial fan or plain, it may be found that the river is flowing between natural levees at a level somewhat higher than the surrounding area. In this case avulsion is inevitable. Crossing of alluvial fans often poses continual maintenance problems due to aggradation of the channel and its tendency to sudden and drastic shifts in alignment (avulsion). It is normally preferable to cross near the apex or head of the fan where the opportunity for channel shifting is limited.

4. DEGRADATION AND AGGRADATION

In this chapter, we present hazards contributing to gradation problems and the description manner is the same as previous [chapter](#).

4.1 AGGRADATION

Aggradation is defined simply as the raising of a streambed by deposition. Aggradation is not local fill, but rather a major adjustment of a river to external controls. Fill is a local raising of the streambed that does not influence the longitudinal profile or gradient of the stream except locally.

The main effect of channel bed aggradation and fill is to reduce bridge clearance. However, aggradation may continue to the extent that new hazards are generated. For example, it may cause avulsion, meanders to cutoff, and channel pattern change. In addition, aggradation may lead to bank erosion as bar formation changes flow paths, and decreased channel capacity will increase flooding with the potential for damage to the bridge and its approaches.

Aggradation may be recognized only after it has become a significant factor causing overbank deposition and bank erosion. However, where the channel is being rapidly aggraded, the process is easily recognized. Patterns of deposition on the channel bed and flood plain and burial of trees, fences, and other structures may be evidence of aggradation. The clearest evidence of aggradation is usually morphologic. A significant increase in the width-to-depth ratio with time may also be an indication of scour and aggradation. Aggradation is also indicated by the appearance of sand and gravel bars where they did not previously exist ([Pfankuch 1975](#)), and in general the development of a braided channel. Reaches near the confluence of large streams and immediately upstream of reservoirs are susceptible to aggradation, as are flow expansion zones downstream of bridges, areas upstream of culverts and locations where debris accumulates ([Neill 1973](#)). An increase of overbank flooding may indicate aggradation or channel capacities are reduced. Although the main channel frequently may not show evidence of aggradation, the smaller tributaries joining the channel will also be aggrading as a result of a rising base level. If such a consistent pattern of tributary aggradation and backfilling can be detected, it is evidence of main channel aggradation.

4.2 BACKFILLING AND DOWNFILLING

Backfilling is deposition of channel filling from downstream to upstream. Backfilling differs from aggradation as defined earlier because it starts at one location in the channel and then is propagated upstream. Downfilling occurs when deposition progresses in a downstream direction, and it is the reverse of backfilling.

Consequences of backfilling and downfilling at a bridge site will be similar to those of aggradation. The channel bed will rise as the wave of sediment passes, and the clearance beneath the bridge will be decreased. Increased flooding will result as the channel fills, and this may cause erosion of bridge approaches and perhaps even a bypassing of the bridge site.

The identification of backfilling and downfilling will be much easier than the recognition of aggradation because not only is the change progressive through time, but also it is progressive along the stream channel. A change in the width-depth ratio of the channel from a low to a high value with no other apparent control will indicate backfilling and downfilling. The channel pattern may change to braided in the reach where deposition is dominant, and evidence of more frequent overbank flooding should be apparent. All of the evidence of aggradation can be used as evidence for backfilling and downfilling once this process has begun in a reach.

4.3 NICKPOINT MIGRATION

A nickpoint is an abrupt change or inflection in the longitudinal profile of the stream. A nickpoint in alluvium moves upstream, especially during floods. As the nickpoint migrates past a point, a dramatic change in channel morphology and stability occurs.

The result of nickpoint formation and migration is, of course, lowering of the streambed. Erosion will be dramatic as a headcut or nickpoint migrates under a bridge. As the nickpoint migrates further upstream, the quantity of sediment delivered to the reach at which a bridge is located increases greatly due to the erosion of the bed upstream and subsequent erosion of the banks of the stream. Therefore, a period of degradation may be followed at a bridge by a period of aggradation.

The most obvious and simplest way to identify nickpoints is by the use of aerial photographs. On topographic maps of large scale, the nickpoint will be represented by closely spaced contours. Of course, if longitudinal profiles are available or can be surveyed, they will show the break in the longitudinal profile of the stream that is the nickpoint. A change in the dimension of the channel and a change in the character of the bankline may indicate nickpoint migration. A low width-depth ratio below the nickpoint is an indication of scour and deepening of the channel. Bank erosion is also a possible consequence of nickpoint migration and a shape change in the bankline characteristics representing a change from stability to instability may identify the position of a nickpoint. It may also be possible to identify the location of a nickpoint by studying riparian vegetation. The passage of a nickpoint may cause the death of trees, which are frequently replaced by other types of hardy drought-resistant plants.

4.4 DEGRADATION AND SCOUR

Degradation is defined as the lowering of a streambed by erosion. Degradation is not local scour, but rather it is a major adjustment of a river to eternal controls. The adjustment takes place over long reaches of channel. Scour, on the other hand, is local erosion of the streambed that, except locally, does not influence the longitudinal profile or gradient of the stream.

The effect of degradation and scour is to deepen the stream channel. Many bridges are wholly or partially supported by the friction generated between the piles and the underlying alluvium. When degradation and scour occur around the bridge foundation, the soil resistance support is reduced, and the bridge may fail. The deepening of the channel may also cause the undermining of banks and widening of the channel with failure of the approaches.

It may be difficult to identify a reach of channel that is being degraded or scoured when the process is in its early stages or if the process is slow. In fact, without other data bed erosion may

be recognized only after it has become a significant factor causing bank erosion or instability of structures. The development of a thin armor of coarse sediment due to hydraulic sorting usually indicates that degradation has occurred. The armor may have prevented further degradation, but a large flood may breach the armor and renew the process. Relatively infrequent overbank flooding suggests increased channel capacity. If floodplain vegetation and soil indicate relatively infrequent overbank flow, the incision is a possibility. Although the main channel may not show clear evidence of degradation, smaller tributaries to the channel will be degrading as a result of main channel incision, or they may contain nickpoints. If such a consistent pattern of tributary degradation and nickpoint distribution can be detected, it is evidence of main channel degradation.

5. RAPID CHANNEL STABILITY ASSESSMENT METHOD

There are basically two ways to identify stream instability at bridge sites and to assess their potential effect on a bridge site. The first is a historical approach by stream reconnaissance and field inspection that utilizes existing information to recognize channel change. The second is to use remote sensing techniques like aerial photographs.

5.1 STREAM RECONNAISSANCE AND FIELD INSPECTION

The most comprehensive method of documenting stream and watershed conditions is through the use of a detailed geomorphological stream reconnaissance. [Thorne \(1998\)](#) developed a comprehensive handbook that can be used to qualitatively and quantitatively document stream channel and watershed conditions. Thorne's handbook includes stream reconnaissance record sheets and guidelines for a detailed geomorphological stream reconnaissance. [Johnson et al. \(1999\)](#) reviewed existing methods and parameters for evaluating channel stability and developed a systematic rapid channel stability assessment method for gravel bed channels.

The following items present the techniques of measuring identification for meander migration and gradation problems at bridge sites:

- Measurement from a known point to the bank of the channel can provide information on bank erosion.
- Change in the width of the channel through time will provide a basis for calculating the rate of bank erosion, although it may not be possible to determine whether both banks or only one bank is eroding. Also comparison of the old maps with more recent U.S. Geological Survey topographic maps may provide information on the rate of channel change or the lack of it.
- The history of bridge failure or bridge problems may provide clues as to the nature of river change or the lack of it through time. At most bridge sites the height of the crown of the road above the channel is given on the plans of the bridge. A simple measurement from the road crown to the bed will provide a check on this distance and perhaps information on degradation or scour at that site.
- Gauging station records for a given discharge will show if there is a change in the water surface elevation through time. If there has been a decrease in gauge height for a given discharge, this is clear evidence that the river is degrading during that period.

5.2 REMOTE SENSING TECHNIQUES (AERIAL PHOTOGRAPHS)

Historically, aerial photography has been by far the most common form of remotely sensed data. Highway agencies often use aerial photography for photogrammetric and planning. Airphoto interpretation needs to be supplemented by field study of the stream, not only at the crossing site but also for a distance of 25-50 channel widths upstream and downstream from the site. The

purpose of field study is to make observations on such features as bank stability, stream depth at pools and riffles, size of bed material, and the potential for floating drift.

If a sequence of aerial photographs can be obtained that were taken during a period of several decades, and particularly if the photographs were taken during low water, a comparison of the photographs will show changes in channel morphology during that period. If maps or aerial photographs of good quality are available, it is frequently possible to measure the amount of bank erosion that has occurred in the past. When no historical information is available, it may be possible to determine rate of channel shift by study of vegetation distribution on the floodplain. [Hickin \(1974\)](#), [Hickin and Nanson \(1975\)](#), and [Everett \(1968\)](#) have made use of dendrochronology to date the migration of the Beatton and Little Missouri Rivers. Rates of channel widening can be directly determined by dendrochronology of failed vegetation on unstable stream banks, the rate of lateral erosion at a site being determined from the average width of a failure zone divided by the time since failure.

[Brice \(1982\)](#) presents a useful procedure for measuring lateral bank erosion rates from aerial photographs.

6. PREDICTION OF MEANDER MIGRATION

6.1 BEGIN, Z. B., 1981, “STREAM CURVATURE AND BANK EROSION: A MODEL BASED ON THE MOMENTUM EQUATION.”

The centripetal force is responsible for deflecting the flow around the bend and is equal to the apparent reactive force of the flow on the bend. Based on this concept of centripetal force, the **equation** for the radial stress (ϕ_r) of flow on a meander bend is:

$$\phi_r = \frac{F}{A_b} = \frac{\rho QV}{Y(R_c + W/2)} \quad (6.1)$$

where:

- F (N) = centripetal force
- A_b (m^2) = area of outer bank
- ρ (kg/m^3) = fluid density
- Q (m^3/s) = discharge
- V (m/s) = flow velocity
- Y (m) = mean flow depth
- R_c (m) = radius of curvature
- W (m) = top width

Although it is not suggested that the radial stress is directly responsible for meander bend migration or failure of bank protection countermeasures, Begin did show that the radial stress is related to meander migration.

6.2 BEGIN, Z. B., 1986, “CURVATURE RATIO AND RATIO OF RIVER BEND MIGRATION UPDATE.”

Using the momentum **equation** it was shown (Begin 1981) that the radial force, F, per unit bank area A exerted by a flow on the external bank of a circular river bend is:

$$\frac{F}{A} = C_u C \cdot \frac{\sqrt{2(1 - \cos\theta)}}{\theta} \cdot \rho U^2 \quad (6.2)$$

where:

- F = radial force
- A = unit bank area
- C_u = a non-dimensional constant relating mean flow velocity U to thalweg velocity U_t ,
($C_u = U_t/U$)
- θ = the deflection angle (in radians) of the bend
- ρ = water density

U = mean flow velocity

C = a non-dimensional constant defined as follows:

$$C = \frac{\left(1 + \frac{1}{2} \frac{w}{R}\right)^{-D \tan \alpha}}{\frac{R}{w} + \frac{1}{2}} \quad (6.3)$$

where:

w = channel width

R = the radius of river bend at its center line

D = a constant relating the channel bottom topography y/r to ϕ

ϕ = the angle of deviation between the directions of the bottom flow and the mean flow
(Rozovskii 1961)

$$\tan \phi = D \frac{y}{r} \quad (6.4)$$

where:

y = local flow depth

r = radius of curvature

The constant $\tan \alpha$ is the dynamic friction coefficient of the bedload due to mutual collisions between grains, its values lying between 0.37 and 0.75 (Bagnold, 1966).

If for several bends in a certain reach of stream, C_u , θ , ρ , and U are assumed to be constant, the differences in the radial force per unit area acting on the external bank, from one bend to another, are dependent upon the curvature coefficient C.

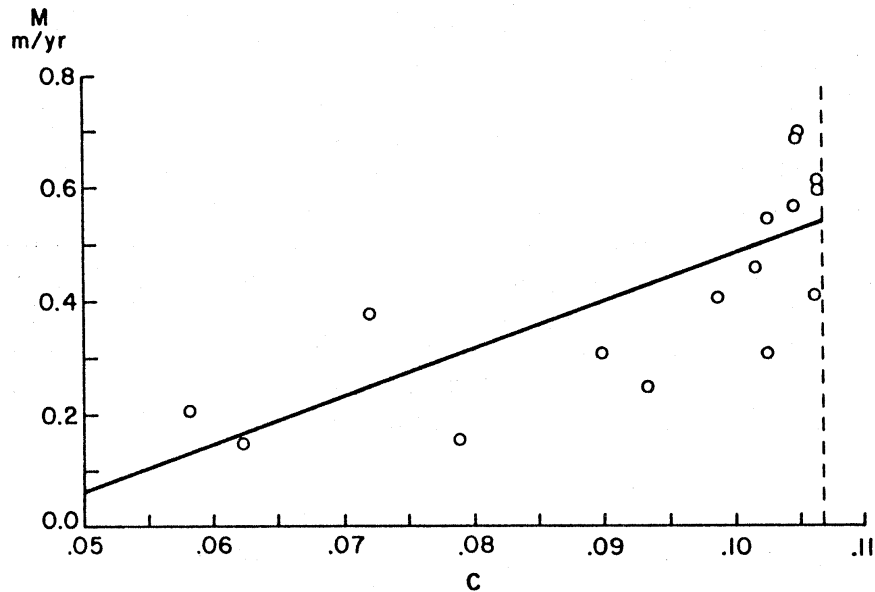
The correlation between M and C for the 16 bends of the Beatton River (Table 6.1) is shown in Figure 6.1, in which C was calculated taking $D = 11$ and $\tan \alpha = 0.58$. On the basis of this correlation, Fig. 6.1 was drawn with a linear correspondence between M and C.

Table 6.1. Data on Bend Curvature and Rate of Bend Migration for Beatton River, Canada.

Site number ^a (1)	R/w^* (2)	C^b (3)	Rate of bend migration ^a (M), m/yr (4)
1	2.96	0.106	0.62
2	3.45	0.107	0.60
3	2.38	0.102	0.31
4	2.65	0.105	0.70
5	2.87	0.106	0.41
6	3.97	0.105	0.57
7	6.34	0.090	0.31
8	1.18	0.062	0.15
9	4.42	0.102	0.55
10	2.31	0.102	0.46
11	1.35	0.072	0.38
12	13.00	0.058	0.21
13	1.90	0.093	0.25
14	8.17	0.079	0.16
15	4.84	0.100	0.41
16	3.94	0.105	0.69

a: From [Nanson and Hickin \(1983\)](#)

b: Calculated through [Eq. 6.3](#), with $D = 11$ and $\tan\alpha = 0.58$



Dashed Line Represents Theoretical Maximum Possible Value of C , for $\tan\alpha = 0.58$ and $D = 11$.

Figure 6.1. Correlation between Theoretically Derived C and Measurements of Bend Migration Rate M . ([Begin 1986](#)).

It is concluded that a wider range of values of the curvature ratio R/w , the curvature coefficient C of Eq. 6.3 is well correlated with the ratio of channel migration M of the Beatton River, taking $D = 11$ and $\tan\alpha = 0.58$. Bank erosion is determined by the shear stress exerted on the bank by stream flow, but this shear stress is proportional to the radial force per unit area acting on the bank. According to the average behavior of M , as represented by C versus R/w curve (Figure 6.2), the rate of bend migration is expected to be close to zero at $(R/w) < 1$ and at $(R/w) > 18$.

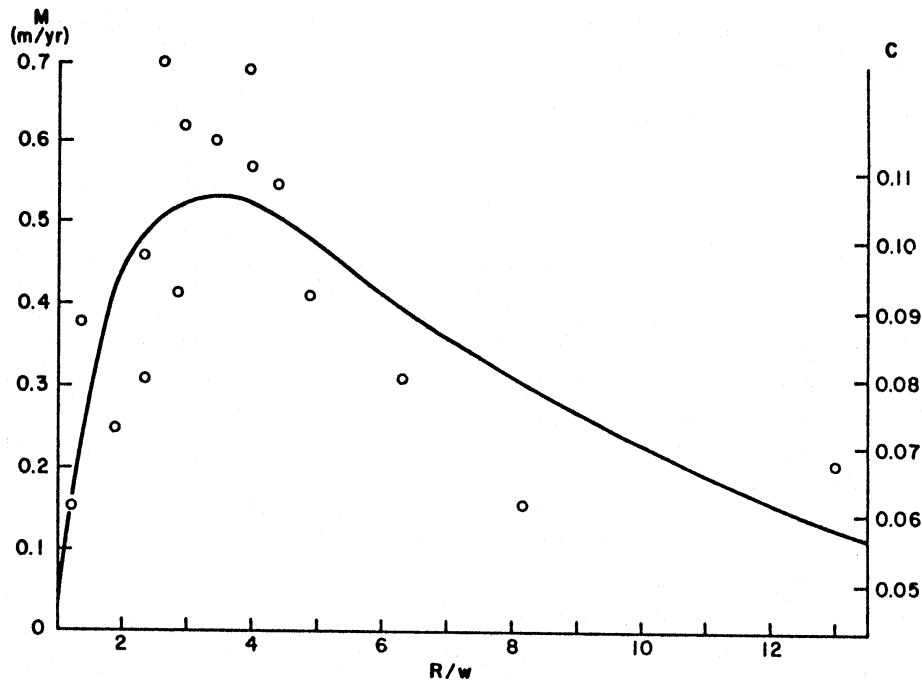


Figure 6.2. Relationship between Stream Curvature R/w , Rate of Bend Migration M in m/yr and Coefficient C (Begin 1986).

6.3 BRICE, J.C., 1982, "STREAM CHANNEL STABILITY ASSESSMENT."

Bank erosion rates for streams are likely to differ from one time span to the next and also from place to place along the stream. Hooke (1980) found that maximum erosion rates occur at discharges near bankfull. The erosion associated with a major flood probably depends more on duration than on magnitude.

Bank erosion rates tend to increase with increase in stream size. In Figure 6.3, channel width is taken as a measure of stream size. The dashed line curve is drawn arbitrarily to have a slope of 1 and a position to separate most equi-width streams from most wide-bend and braided point-bar streams. For a given channel width, equi-width streams tends to have the lowest erosion rates, and braided point-bar streams the highest. Braided streams without point bars plot well below the arbitrary curve because their channels are very wide relative to their discharges. Channel width is an imperfect measure of stream size, as are drainage area and discharge, particularly for the comparison of streams in arid and semiarid regions with streams in humid regions.

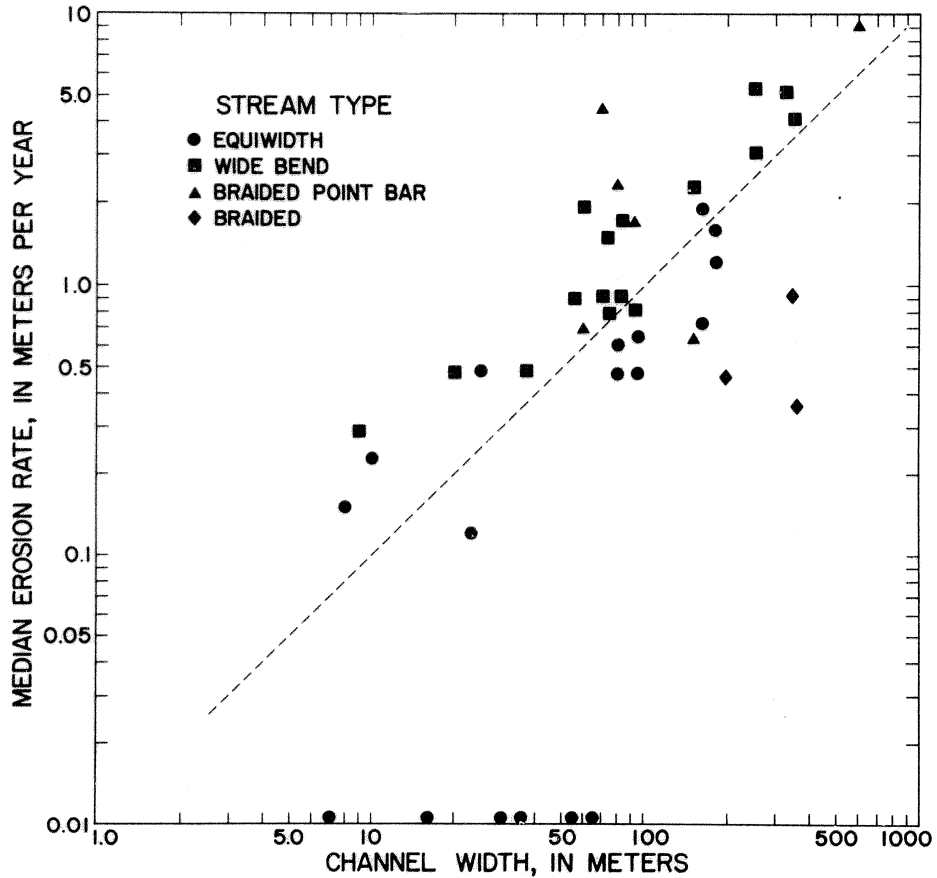


Figure 6.3. Median Bank Erosion Rate in Relation to Channel Width for Different Types of Streams (Brice 1982).

The relation between sinuosity and the erosion index for streams of different type is shown in Figure 6.4. The erosion index was obtained by multiplying the erosion rate in channel widths per year by the percent of reach eroded times 100. For engineering purposes, the relation between sinuosity and stability is summarized as follows:

- Meandering does not necessarily indicate instability. In Figure 6.4, equi-width streams having sinuosity in the range of 2-2.8 are among the most stable streams. An unstable stream will not remain highly sinuous for very long, because the sinuosity will be reduced by frequent meander cutoffs.
- Where instability is present along a reach, it occurs mainly at bends. Straight segments may remain stable for decades.
- The highest erosion index values are for reaches whose sinuosity is in the range of 1.2 to 2 and whose type is either wide bend or braided point bar. An erosion index value of 5 separates these types from most equi-width streams, and it also approximates the rate of erosion at which loss of agricultural land becomes obvious. It is an unstable boundary between stable and unstable reaches.

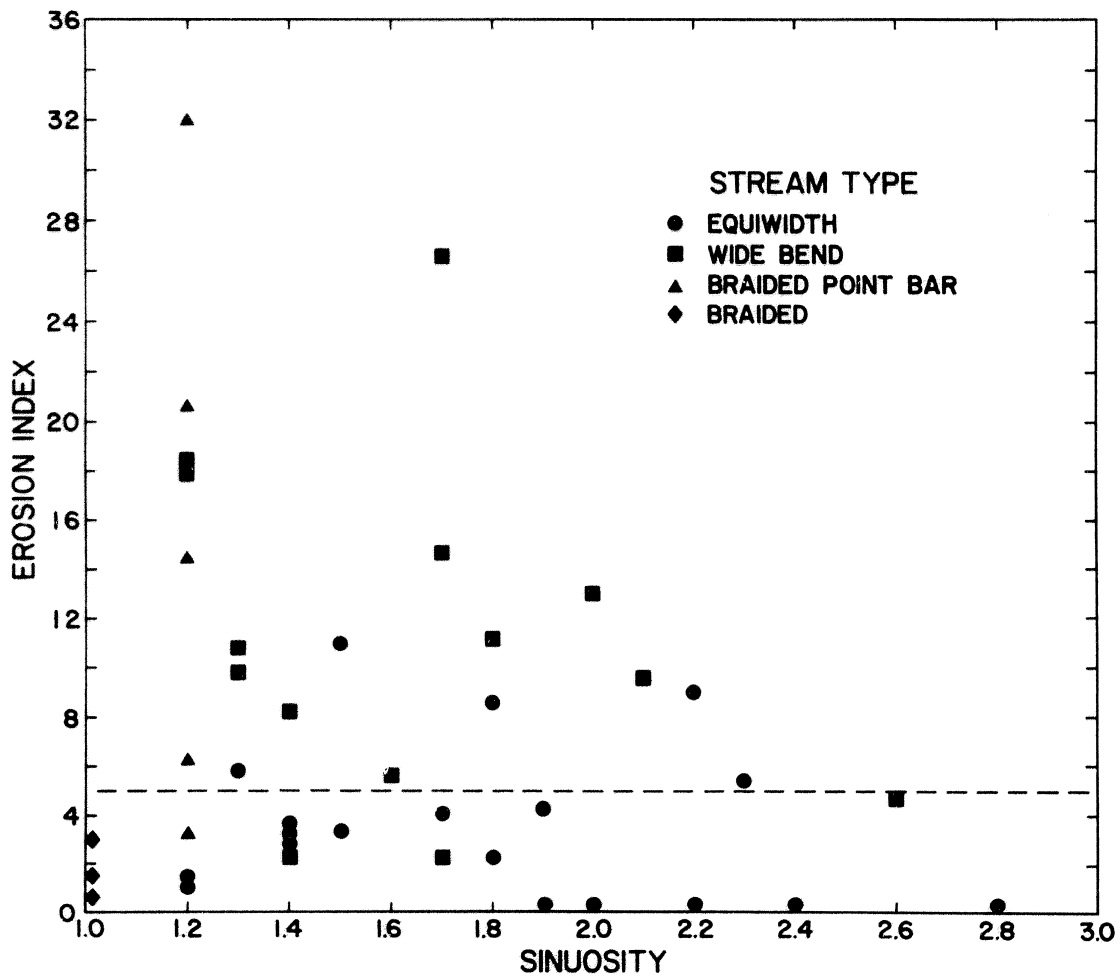


Figure 6.4. Erosion Index in Relation to Sinuosity for Different Types of Streams (Brice 1982).

6.4 CHANG, H.H., 1984, "ANALYSIS OF RIVER MEANDERS."

The meander curvature and other geomorphic features for rivers are analyzed using an energy approach with relations for flow continuity, sediment load, resistance to flow, bank stability, and transverse circulation in channel bends. The analysis establishes the maximum curvature for which a river does the least work in turning. This curvature, stated as the radius of curvature to channel width ratio, has an average value of 3; it shows only minor variation within the meandering range. Meandering development is explained by the river's tendency to seek minimum channel slope for the given conditions. The analysis demonstrates how uniform utilization of power and continuity of sediment load are maintained through river meanders. The maximum curvature in terms of r_c/B is found to be a function of the channel slope, discharge, sediment size, and the average width-depth ratio, as shown graphically in Figure 6.5.

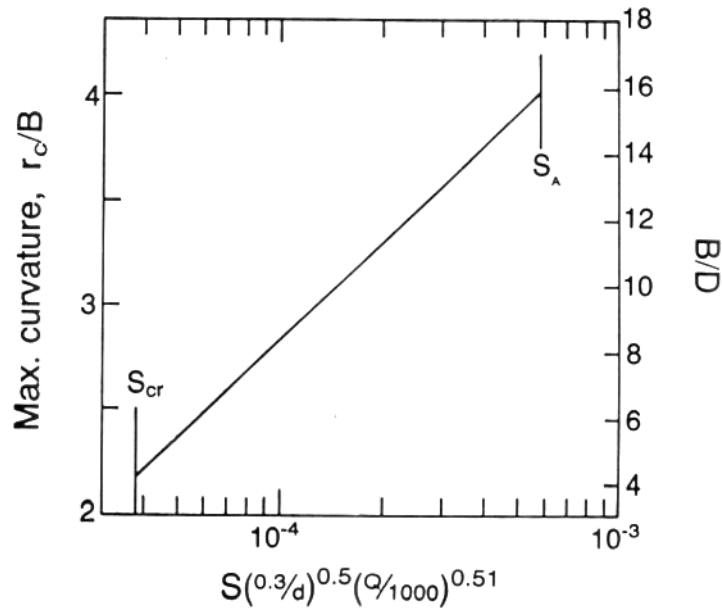


Figure 6.5. Relation of Maximum Curvature with Slope, Discharge, Sediment Size, and Width-Depth Ratio (Chang 1984).

The rate of channel bend migration reaches a maximum value when the value of r_c/B approximates 3. The rate of channel migration rapidly declines for bends with values of r_c/B greater or less than 3. The width-depth ratio is found to be an important factor governing meander geometry. Small values of this ratio indicate the possibility of development of very sinuous channels.

While transverse circulation causes increased power expenditure, the increase is matched by an increase in sediment efficiency contributed by the circulation. The meander geometry is adjusted in such a way that minimum power is expended per unit length of the channel while uniform utilization of power is maintained along the channel reach.

The channel slope is usually less than the valley slope. When the sinuosity, or the ratio of valley slope to channel slope, exceeds 1.5, the river is considered to have a meandering channel pattern. Within the range of meandering rivers, the width stays essentially constant along the channel. The maximum curvature for which a river does the least work in turning is stated as the radius to width ratio, which has an average value of about 3.

6.5 CHANG, T. P., TOEBES, G. H., 1980, "GEOMETRIC PARAMETERS FOR ALLUVIAL RIVERS RELATED TO REGIONAL GEOLOGY."

From the analysis of meandering river planforms such as the Wabash River and the White River systems in Indiana, the following conclusions were revealed:

- (1) the mean radius of curvature, R_m , was found to be a better measure of the size of a meander planform than a statistically determined meander wavelength;

(2) the average discharge, Q_{av} , is found to be a better measure of river size than the bankfull discharge or other measures derived from frequency curve; and

(3) glaciation was used as an indicator for the roles which sedimentation, soil, and local geology have in determining meander planforms. It can be expected that glacial geology reflects soil condition, which controls channel sedimentation and hence meander pattern.

$$R_m = 24Q_{av}^{1/2} \quad (\text{older) Illinoisan glaciation} \quad (6.4)$$

$$R_m = 197Q_{av}^{1/3} \quad (\text{younger) Wisconsin glaciation} \quad (6.5)$$

$$R_m / W = 69Q_{av}^{-1/4} \quad (\text{all glacial regions}) \quad (6.6)$$

where,

R_m (ft) = mean radius of curvature

Q_{av} (cfs) = average discharge

From the above relationship it is seen that the common assumption of linear similarity of meander planform is not true. Instead, the common geometry similarity ratio, R_m/W is a function of flow rate.

6.6 CHITALE, S. V., 1980, "SHAPE AND MOBILITY OF RIVER MEANDERS."

In bend flow, the centrifugal force generates superelevation ' Δh ' given by

$$\Delta h = \frac{\alpha V_m^2 W}{g r_m} \quad (6.7)$$

where:

α = the velocity correction factor

W (m) = the channel width at water surface

V_m (m/s) = the mean channel velocity

g (m/s²) = the gravitational acceleration

r_m (m) = the radius of curvature of the centerline of the channel.

In a straight channel, the velocity distribution across the section is normally such that high velocities occur in the central portion and they gradually reduce towards the banks. In bend flow the effect of secondary circulation is to shift the maximum velocities towards the concave bank; this shift depends on bend angle, boundary friction as reflected by the coefficient 'c' in the Chezy formula, and the shape factor 'D/W' which is the ratio of depth to width of channel section.

Rozovskii (1961) has shown that for a given bend angle and C value, the shift of maximum velocity location towards concave banks is less in the case of smaller values of 'D/W' implying shallower and wider cross-sections. In other words, in shallower and wider channels, the

establishment of higher velocities along concave banks requires a bigger bend angle. Maximum velocities along concave banks are obtained near the apex of the bend in the case of a narrow and deep channel section. They are obtained further downstream beyond the apex of the bend for channels having wide and shallow cross-sections.

In cases of natural channels with erodible bed and banks, higher velocities along the concave bank in a bend create bigger depths. The vertical velocity distribution is also affected due to helieidal flow, and the maximum velocity along a vertical profile is obtained at an elevation below the top, with the result that the side slope of the concave bank becomes steeper due to side erosion. Deeper depth and steeper side slope along the concave bank leads to instability of bank slope in accordance with the relationship

$$h = \frac{4C \cot \phi}{\gamma \quad 2} \quad (6.8)$$

where:

h (m) = the vertical height of stable bank

C (N/m²) = cohesion

γ (N/m³) = specific weight of soil

φ = angle of slope

6.7 COMES, B. M., 1990, "IDENTIFICATION TECHNIQUES FOR BANK EROSION AND FAILURE PROCESSES."

The hydraulic laboratory of the U.S. Army Engineer Waterways Experiment Station (WES) developed techniques to design small flood-control channels. A component of this research is the investigation of bank failure processes. The failure processes have been classified by type of failure, and guidance is being developed to assist field investigators in identifying conditions under which each type of failure occurs.

Several causes that contribute to bank erosion process are:

1. surface soil abrasion:

- rainwater impact,
- aeolian transport,
- ice,
- overbank drainage (rilling and gullyng), and
- waves (wind and vessel induced).

2. subsurface soil alteration:

- frost heaves,
- permafrost,
- piping,

- freeze/thaw,
- stage fluctuation, and
- vegetation.

3. fluvial entrainment:

- vessel propeller forces,
- water currents,
- point bar building, and
- headcutting.

The bank assessment guidelines consist of three sheets: a valley and channel survey, a left-bank survey, and a right-bank survey. The valley and channel survey is divided into sections. The sections address the area around the valley, the valley sides, the vertical and lateral relation of the channel to the valley, and a description of the channel. Information sources for this part of the survey are aerial photographs, plots of the channel's thalweg, soil boring samples, and, of course, a field visit. The left- and right-bank survey forms are identical and contain sections addressing the bank's materials, geometry, and vegetation; the erosion processes and their extent; the bank's failure modes; and the location and nature of the failed material. Additional research is being conducted to investigate the feasibility of dynamic boundary movement in finite element numerical models that could be applied to the calculation of bank failure rates.

6.8 DIEHL, T. H., AND BRYAN, B. A., 1993, "SUPPLY OF LARGE WOODY DEBRIS IN A STREAM CHANNEL."

Accumulations of large woody debris at bridges have caused increased backwater and bank scour at bridges. Tree trunks with attached root masses play a key structural role in debris accumulations at bridges. Debris production is associated with bank instability, which more often occurs throughout stretches of widening channels, and along the outside bank of bends where the channel is migrating laterally. Researchers can detect lateral channel migration and widening on maps and aerial photographs. High and steep banks, erodible bank materials, and a history of channel widening or migration all are useful as indicators of potential bank erosion and consequent debris production.

6.9 GILJE, S. A., MARCH 1979, "DEBRIS PROBLEMS IN THE RIVER ENVIRONMENT."

Many states have identified hazards associated with debris, but the extent and the importance of the problem are not understood. Debris is particularly troublesome in actively meandering streams because of the continuing lateral erosion of the stream banks. Therefore, if possible, piers on straight reaches should not be placed in the mainstream or on the outside of meander bends where debris will flow during the main flood event. It is generally conceded that solid piers with smooth edges should be used in a stream. Furthermore, a logical way to eliminate debris accumulation at bridges is to locate piers out of the main flow. Countermeasures that can be used against debris are deflectors, fins, or cribs and collectors. Deflectors require flow control structures to insure stable flow conditions. Environmental consideration, in addition to

hydrology, hydraulics, and river geomorphology, play an active part when dealing with flood hazards. Debris accumulation at stream crossings is a stream hazard of considerable importance. Countermeasure guidelines are available for debris at culverts, but more guidance is needed for controlling debris at bridges. With costs of bridge construction escalating, the need for improved designs and countermeasures against stream hazards are important in insuring that new structures, and those in existence, serve for as long as possible. Proper recognition of debris problems coupled with the tools needed to deal with debris will do this effectively.

6.10 HAGERTY, D. J., HAMEL, J. V., 1989, “GEOTECHNICAL ASPECTS OF RIVER BANK EROSION.”

The extensive field studies performed at sites on the Ohio River demonstrated that erosion occur through stratified by a combination of mechanisms. The failure of in-place bank soils was initiated by removal of the coarser grained layers in any given alluvial bank by water flowing out of the bank face. This type of mechanism, termed “sapping” or “piping,” has been found in recent years to occur widely in many different environments. With recognition of interflow as an important component of basin drainage, more and more attention has been given to piping as a primary mode of gully and rill formation. The overall stability of a bank consisting of layers of alluvium was found to depend on the permeability, capillary suction, and geometry of the more pervious layers in the sequence of strata. Obviously, if the stream did not remove the debris from the bank failures, a berm would be created, in time, which would inhibit further failures. The maximum height of river rise and the total duration of a flood event were found to govern how far water invaded the pervious layers, and how much of the layers was removed by water flowing back out of the banks. Researchers found the removal of bank soil to be very insensitive to the shape of the flood hydrograph. The strength parameters of the overlying soil layers were found to govern where failure occurred.

Geotechnical aspects of riverbank failure and erosion are highly site-specific as a result of site geologic, geotechnical and hydraulic conditions. The geotechnical framework of each bank reach therefore must be developed in detail sufficient to characterize existing failure and erosion processes, in order to anticipate future bank behavior and to design stabilization measures as necessary.

6.11 HARVEY, M. D., 1989, “MEANDERBELT DYNAMICS OF THE SACRAMENTO RIVER.”

There are both short- and long-term meander migration rates on the Sacramento River because meander migration is a discontinuous process dependent on the occurrence of morphogenetically significant flood flows. Comparison of the short- and long-term migration rates for the bends with R_c values indicates that the long-term migration rates are lower than the short-term rates, which indicates that the recent hydrological record is very important in determining migration rates.

6.12 HASEGAWA, K., 1989, “UNIVERSAL BANK EROSION COEFFICIENT FOR MEANDERING RIVERS.”

A relation for the rate of bank erosion, and thus channel shift, was derived from the equation of sediment continuity. The erosion rate should be proportional to the near-bank excess streamwise flow velocity U_B .

An appropriate estimate of the parameter A (scour factor) allowed for the determination of a relatively high correlation between the erosion rate and the value of the u_B at least for three rivers in Hokkaido.

Sequential maps of river planform can be used on phase shift that optimizes the correlation between the erosion rate and the near-bank excess streamwise velocity. The value of A so obtained, however, is partly a function of the time between the successive maps.

The effective bank erosion coefficient can be expected to be a function solely of bank soil properties, and those decrease as N_d increases; here N_d is the value of the standard penetration test. The curve displaying the higher erosion rate corresponds to banks in which sand and gravel dominate; for clayey beds the curve yields lower erosion rates. Furthermore, the erosion rate tends to be modest when the bed material adjacent to the bank is very fine or very coarse, but becomes largest for the case where the adjacent bed material is medium to coarse sand.

6.13 HERR, L.A., 1970, “THE CONTROL OF EROSION AND SEDIMENT IN HIGHWAY CONSTRUCTION.”

The cost of maintaining our highways increases as our highway mileage increases, and the public expects better service nowadays. It is not possible to build a highway that requires no maintenance. Instead we try to protect the right-of-way in a manner that keeps erosion to a minimum and is easy to maintain. Mild slopes and wide channels with grass cover in humid regions give a good appearance and can be maintained with power equipment. Natural vegetation, such as shrubs and trees reserved or planted in certain areas of the right-of-way, provides excellent protection from erosion and requires little attention.

Erosion and scour of the banks and beds of streams and rivers are problems, both during design and construction of our highways and for years after they are built. Rivers change course and meanders move downstream which makes our bridge piers and abutments vulnerable to attack by the main current. In some cases, the initial main river bridge becomes ineffective as a waterway. In such a case expensive revetments or additional openings must be constructed. Channel changes made downstream from our highway structures cause degradation of streambeds, which makes foundations of existing bridges unsafe and has caused failures. Maintenance engineers must watch highway drainage structures and streams adjacent to the highway to detect and correct serious scour and erosion before a failure occurs. This is particularly true where flood control works or channel changes might affect channel stability.

When crossing streams that had wide flood plains, we found that it is both economical and feasible in some locations to use embankments in combination with bridges. However, the flood flow diverted from the flood plain by the embankment must pass through the bridge opening.

This lateral flow can cause severe scour around the bridge abutment, even to the extent of causing failure of the structure. In such locations we have made extensive use of spur dikes, either permeable or earth fill types. These dikes aid in aligning the flow through the structure and move the scour hole upstream and away from the bridge. Sometimes spur dikes are installed as a remedial measure after severe scour develops.

Most highway engineers recognize that they must consider erosion control in the design and construction phase rather than the old way of taking care of it with maintenance forces. We are all aware that disturbing the soil during any construction, highway or otherwise, inevitably brings some sediment and turbidity to our streams, but with proper design and careful construction we can build a product which is functional and reasonably safe with minimum disturbance to natural values.

6.14 HICKIN, E. J., 1977, “THE ANALYSIS OF RIVER-PLANFORM RESPONSES TO CHANGE IN DISCHARGE.”

Meandering empirical relationships are as follows:

$$\frac{\lambda}{W} \cong 10 \quad \frac{\lambda}{R} \cong 4 \quad \frac{R}{W} \cong 2 \quad \lambda \cong 10Q^{0.5} \quad W \cong Q^{0.5} \quad (6.9)$$

where:

λ = meander wavelength (m)

W = bankfull channel width (m)

R = radius of channel curvature (m)

Q = bankfull discharge (m³/s)

The results produced using data taken from nine meandering reaches in this paper are different to these equations because of distortions resulting from strong or weak boundary materials from the formation of cut-offs and other disturbing factors. In spite of the apparently subjective basis for equations, some subsequent research in open channel hydraulics suggests that such relations should indeed exist.

6.15 HICKIN, E. J., AND NANSON, G. C., 1984, “LATERAL MIGRATION RATES OF RIVER BENDS.”

The channel migration rate is essentially affected by a sediment transport. If the effects of bend curvature are held constant for the Beatton River, dimensional analysis yields an expression in which migration rate is related to the ratio of driving to resisting forces in the bed.

The parameters γ_b (coefficient of bank strength or of resistance to lateral erosion) is largely dependent on grain size, and the task of specifying the channel migration process is essentially a bed sediment entrainment problem.

They show that $Y_{2.5}$ (lateral migration for $r_c/W = 2.5$) is a simple function of stream power per unit channel length Ω ($\Omega = \tau VW = \rho g QS$), outer bank height (thalweg to bank crest) h , and a coefficient of resistance to lateral migration γ_b

$$Y_{2.5} = Y \left[\frac{(r_c / W)}{2.5} \right] \quad \text{for } r_c / W \geq 2.5 \quad (6.10)$$

$$Y_{2.5} = Y \left[\frac{1.5}{(r_c / W) - 1} \right] \quad \text{for } 1 \leq r_c / W < 2.5 \quad (6.11)$$

where:

$$\frac{Y_{2.5} h}{\Omega} = \text{constant for a given bank strength} = \frac{1}{\gamma_b}$$

6.16 HOOKE, J. M., 1980, "MAGNITUDE AND DISTRIBUTION OF RATES OF RIVER BANK EROSION."

The rates of bank erosion in rivers in Devon, England, over a 2.5-year period (Jan. 1974 to June 1976) are compared with those published in the literature and derived from maps for various time periods between 1840 and 1975. The map rates are generally lower than the field rates. The difference is due to the methods of measurement, but this seems unlikely to account for the magnitude of the change in rate at some sites.

A second possible cause of the difference in rates is the magnitude-frequency of events, including a change in discharge conditions or the inherent variations in channel activity such as change in land use, increase in urbanization, and changes in agriculture. The rates vary considerably even between sites close to one another on the same stream, experiencing similar conditions of discharge, precipitation and temperature. This variation implies that the characteristics of the sites themselves influence the rates of erosion.

A comparison of the rates from the Devon streams with worldwide published rates (Figure 6.6) demonstrates that the Devon rates are not abnormally high and comparable rates have also been measured elsewhere in the British Isles. Figure 6.6 show some relationship to size of stream as measured by catchment area. A multiple regression analysis used to investigate the influence of site factors on rates of erosion revealed the extent of the scaling factor and the square-root relationship between rate and catchment area. So the following equations are derived.

$$Y \text{ (m/year)} = 8.67 + 0.114 A \text{ (km}^2\text{)} \quad (r = 0.73) \quad (6.12)$$

$$Y = 2.45 A^{0.45} \quad (r = 0.63) \quad (6.13)$$

where:

Y (m/year): bank erosion rate

A (km²): catchment area

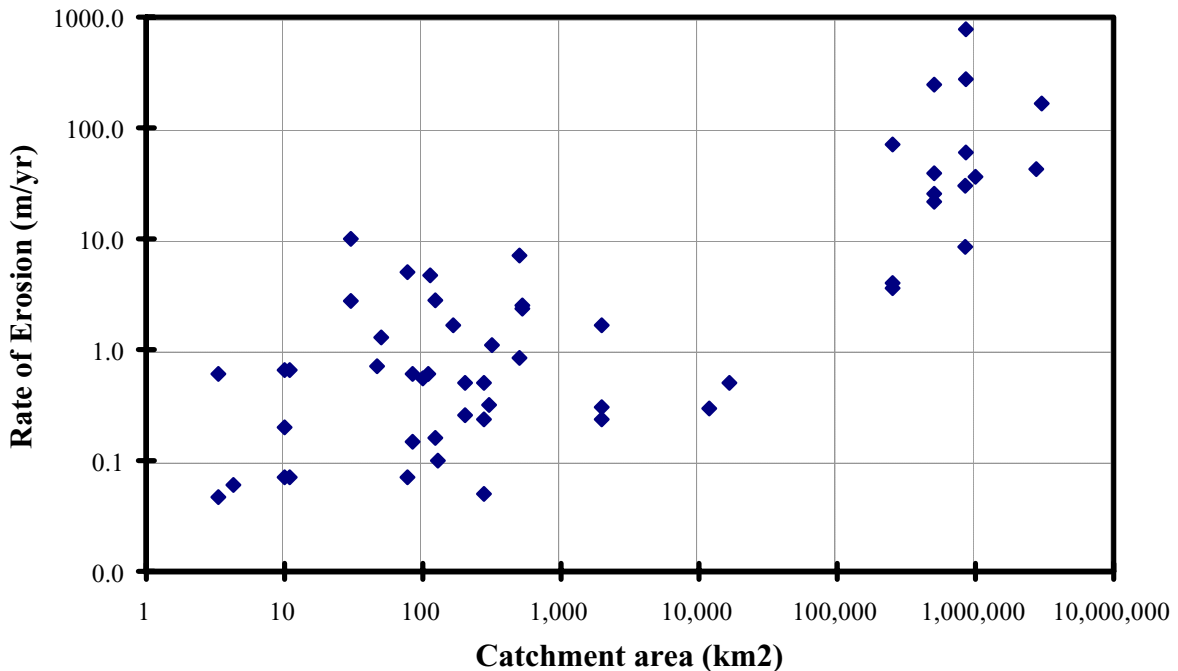


Figure 6.6 Relationship between Erosion Rates and Catchment Area (Hooke 1980).

6.17 HUDSON, H. R., 1982, “A FIELD TECHNIQUE TO DIRECTLY MEASURE RIVER BANK EROSION.”

Presently used techniques have provided valuable information on processes and rates of retreat. However, inadequacies in these techniques were found in common field situations. Present methods of measuring riverbank erosion suffer from two major handicaps. Firstly, they often inadequately describe the form of the bank, which may result in an inaccurate amount and rate of material removal. Secondly, existing techniques may not be able to record intermediate rates of bank erosion, which may be the most important events over the long term (Wolman and Miller 1960).

Bank profiling is a hybrid of horizontal straight edge leveling (Trutman, undated), baseline surveys (Wolman 1959), and multiple erosion pin surveys (Twidale 1964).

The technique may provide details of bank erosion of intermediate magnitude (0.10-10 m) over periods of days to years. When retreat is generally small but where great rates of erosion might result from extraordinary bank scour and/or collapse, the technique may be used in conjunction with erosion pin measurement. With very rapid, larger magnitude (meters per hour) bank retreat, the potential hazard to personnel suggests baseline to bank edge measurements, supplemented by photography, would be all that are feasible.

6.18 KEADY, D. M., PRIEST, M. S., 1977, “THE DOWNSTREAM MIGRATION RATE OF RIVER MEANDERING PATTERNS.”

The purpose of this study is to develop a generalized relation from which the downstream rate of meander migration in alluvial materials could be determined. It was presumed that this could be accomplished, to some degree, by analysis of data already available in published reports on particular rivers, maps and related data, and airphotos and related data. The analysis would, of course, be subject to constraints imposed by the available data. Only relatively free meander patterns were considered in this study (That is, those subject to minimal influence by man’s activities).

It seems reasonable to assume that the rate of downstream migration is somewhat related to an intensity of boundary shear, which, in turn, might be related to free surface slope of the river and the specific weight of the water. Using meander amplitude as a measure of stream and channel size and preserving dimensional balance, the following equation is derived:

$$\frac{V}{\sqrt{gA}} = \phi(s) \tag{6.14}$$

Where:

- V (ft/yr) = rate of migration
- g (ft/sec²) = gravity
- A (ft) = meander amplitude
- S = free surface slope
- φ is function of slope

Here, the meander amplitude was taken as one-half the lateral distance between the envelopes of the thalweg extremities. Free surface slopes were determined from surface profiles or measurements from contour maps. The data used in this study were obtained from published reports by Causey, on the Red River in Arkansas and Louisiana, and Neill and Galay, on the Red Deer River in Alberta, Canada. Data used in the analysis are shown in Table 6.2, and the results of the study are shown in graphical form in Figure 6.7.

Migration rate peaks when $S \times 10^4 = 1.5$. The shape of the curve should be of particular interest to persons responsible for locating and safeguarding structures in the proximity of large streams.

Table 6.2. Data Used in the Analysis.

Identification	Velocity of Migration ft/yr	Meander Amplitude ft	Slope
Mississippi R (LA)	60	13,000	.0000436
Mississippi R (MS)	111	11,000	.0000588
Mississippi R (TN)	225	13,200	.0000777
Red R (ARK)	350	2,900	.000132
Pearl R (LA)	20	1,050	.000200
Red Deer R (Canada)	20	1,200	.000275

Tombigdee R (MS)	13	800	.000421
Buffalo R (MS)	17	1,560	.000689

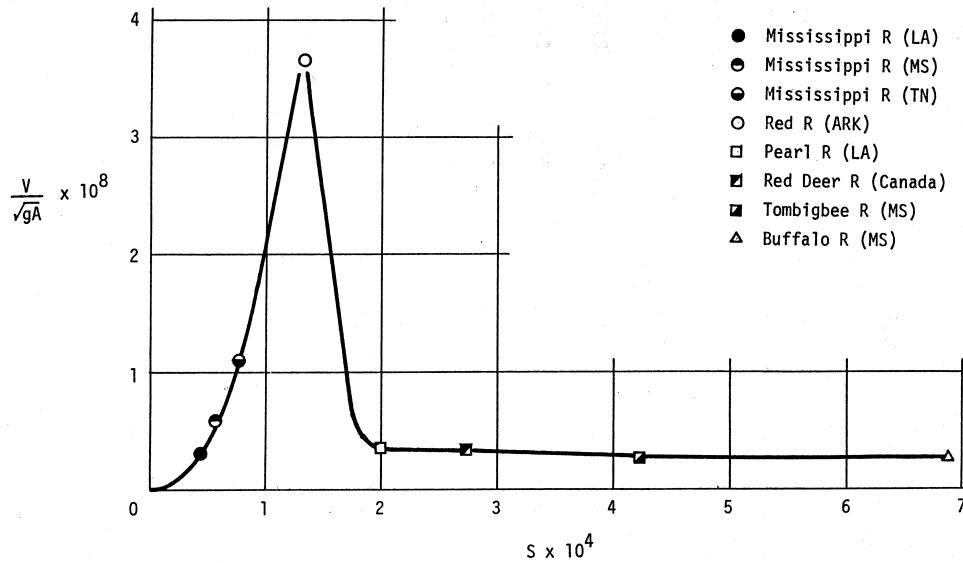


Figure 6.7. Graph for Determining Rate of Meander Migration (Keady 1977).

6.19 LAGASSE, P. F., SCHALL, F. J., RICHARDSON, E. V., 1999, "STREAM STABILITY AT HIGHWAY STRUCTURES," THIRD EDITION.

Channel widening can be caused by either aggradation or degradation of the channel produced by changes in the contribution of water and sediment to the reach. As the channel aggrades, the channel will attempt to maintain or adjust its principal components including its cross-sectional area. The following relationship indicates the influence of each parameter.

$$Q_s^+ \propto W^+, Y^-, (W/Y)^-, \lambda^+, P^-, S^+ \quad (6.15)$$

where:

Q_s (m^3/s) = sediment load

W (m) = width

Y (m) = depth

λ (m) = meander wavelength

P = sinuosity

S = slope or gradient

The + or - sign represents an increase or decrease, respectively, in the channel form variable. According to this relationship, an increase in the sediment load can cause widening and shallowing of the channel.

Increased discharge as a result of increased runoff produced by land use or climatic changes may result in channel degradation or incision as shown by the following relationship

$$Q^+ \propto W^+, Y^+, (W/Y)^+, \lambda^+, P^- \quad (6.16)$$

where:

$$Q \text{ (m}^3\text{/s)} = \text{water discharge}$$

6.20 LANGBEIN, W. B., LEOPOLD, L. B., 1966, “RIVER MEANDERS – THEORY OF MINIMUM VARIANCE.”

Meander geometry in terms of a sine-generated curve is defined by the following equation.

$$\theta = \omega \sin\left(\frac{2\pi X}{\lambda}\right) \quad (6.17)$$

where:

θ = channel direction

ω = the maximum angle between a channel segment and the mean downvalley axis

X = sinusoidal function of distance

This curve approximates the curve of minimum variance, or least work in turning around the bend, and describes the form of symmetrical meander paths relatively well. However, real meanders are asymmetrical and deviate significantly from idealized, perfectly symmetrical, sine-generated curves. Bend asymmetry occurs because the point of deepest scour and maximum attack on the outer (convex) bank in a bend is usually located downstream of the geometric apex of the bend. This causes the bend to migrate downstream through time, becoming skewed in the downvalley direction as it shifts.

6.21 LEVENT, V., 1991, “MEANDER BEND EXPANSION AND MEANDER AMPLITUDE DEVELOPMENT.”

The movement of a meander bend may be resolved into two components: the bend expansion and bend migration. The bend expansion is the bend movement in the direction perpendicular to the downvalley direction. Such a movement will result in an increase of the meander amplitude. The bend migration, on the other hand, is defined as the downvalley direction movement of the bend apexes. This paper concentrates on the bend expansion and its direct result, i.e. the meander amplitude development. Meander bend expansion is caused mainly by erosion of the concave bank. Based on this principle, a formula is derived in which the expansion rate is functionally related to the bend concavity. The theoretical model is verified and tested with experimental data, and the results show good agreement between the predicted and measured meander amplitude. Based on the relational between the bend expansion and the sediment transportation, a meander bend expansion rate formula is derived, which expresses the bend expansion rate.

Three dimensions have been introduced to describe meanders. They are the length, width, and curvature of a meander, shown in Figure 6.8.

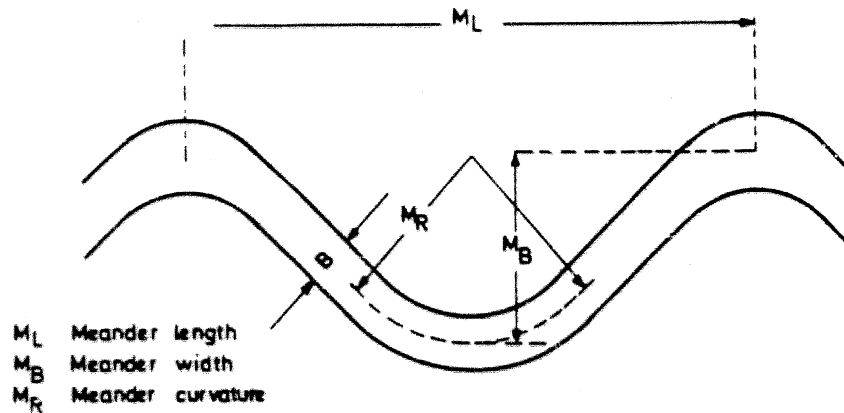


Figure 6.8. Definition Sketch for a Meander (Levent 1991).

The analysis by Inglis (1947) confirmed that both meander length and meander width vary with the discharge, and the meander length was given by $M_L = C_i(Q)^{1/2}$ where, C_i is $25 < C_i < 30$. It was found that the ratio M_B/M_L is of the same order, or $M_B/M_L \approx 2.5$ for both incised and flood plain meanders.

The rate of bend expansion is defined as the distance by which the apexes of a concave bank retreat in the lateral direction per unit time, and is denoted as dy_b/dt (Figure 6.9).

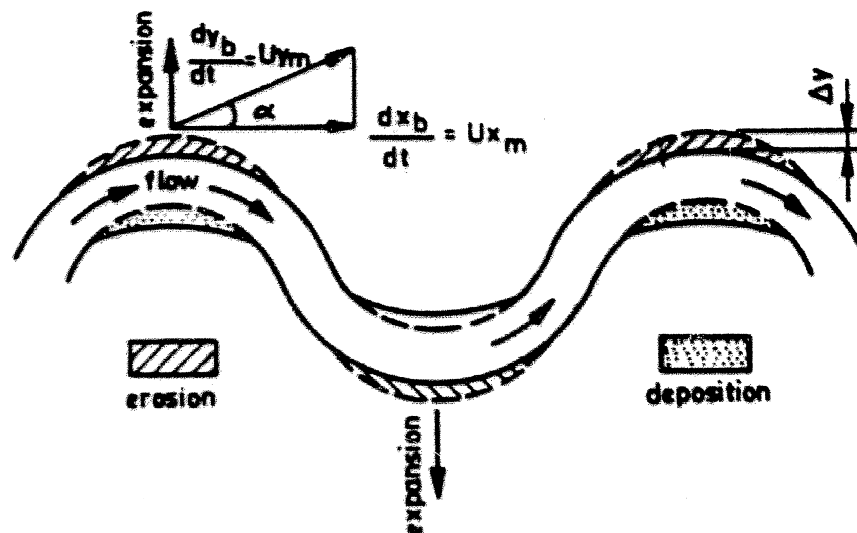


Figure 6.9. The Movement of a Meander Bend (Levent 1991).

In order to simplify the problem, the following assumptions have to be made: (1) the flow is steady and the sediment is uniform and non-cohesive, (2) the meander bends are circular, and (3)

the bend expansion is due to the concave bank erosion. The last assumption relates the bend expansion rate to the rate of the sediment transport rate by the following **equation**.

$$q_{b\ wh} = \frac{h_u \cdot L}{n} \cdot \frac{d_{yb}}{dt} \quad (6.18)$$

where:

- $q_{b\ wh}$ (m^3) = the whole bedload of meander bend
- h_u (m) = flow depth at meander bend axis
- L (m) = meander bend length
- d_{yb} / dt = the rate of bend expansion
- $1/n$ = constant because the flow depth varies with time

The flow resistance in a meander bend is considerably increased due to the form resistance of the patterns which not much is known about. It depends on a number of factors including grain friction, form resistance of two and three-dimensional patterns, skin friction of the non-separated oscillatory component, and the sediment transport rate. The sediment transport coefficient is a linear increasing function of the discharge. The causes that are considered as the origin of a meander are: (1) local disturbances, (2) earth rotation, (3) excessive energy, (4) change in river stages, and (5) forced oscillations. However, due to superelevation, a spiral flow is introduced and, thus a non-symmetric mass transport is produced.

6.22 **LIGENG, L., SCHIARA, M., 1989, "MEANDER BEND EXPANSION AND MEANDER AMPLITUDE DEVELOPMENT."**

The rate of the bend expansion is defined as the distance by which the apexes of a concave bank retreats in the lateral direction per unit time (**Figure 6.10**) and is denoted as (dy/dt) .

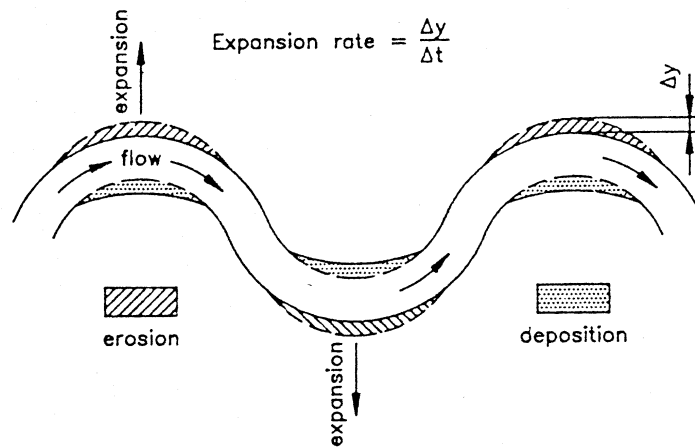


Figure 6.10. Definition of the Expansion Rate (dy/dt) (Ligeng 1989).

$dy/dt = q_w$ where q_w is the volumetric sediment transport rate per unit width of the wall surface. Introducing the bedload sediment transport formula by Meyer, Peter and Muller (1948), the following equation resulted

$$\frac{\partial y}{\partial t} = \frac{8\Phi(\tau - \tau_c)^{1.5}}{\Delta^2 g} \quad (6.19)$$

where:

τ = the shear stress exerted on the bank wall

τ_c = the critical shear stress for sediment movement

$\Delta = (\rho_s - \rho) / \rho$

ρ_s = the densities of the sediment

ρ = the densities of the water

Φ = the sediment transport coefficient introduced in order to apply the bedload formula for the bank wall

For non-cohesive bank material, the critical shear stress for sediment incipient motion is negligible in comparison to the actual shear stress causing continuous bank erosion. Hence the above equation is reduced to

$$\frac{\partial y}{\partial t} = \frac{8\Phi}{\Delta^2 g} \tau^{1.5} \quad (6.20)$$

Because of the three dimensional flow at a river bend, the total shear stress exerted on the wall can be divided into the vertical and longitudinal components (Figure 6.11)

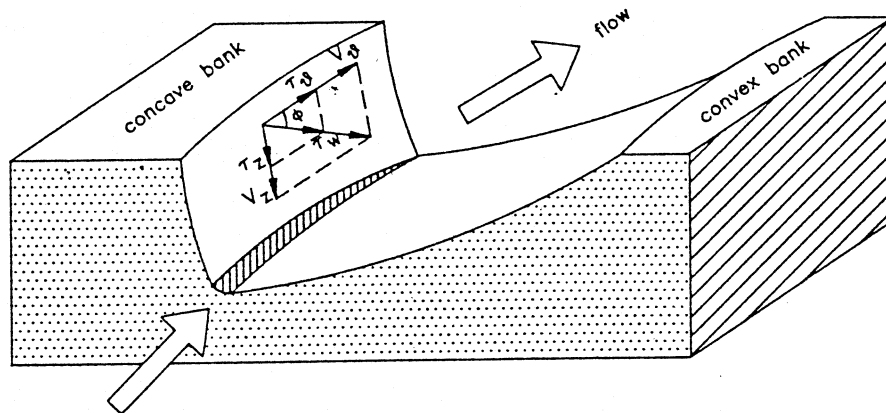


Figure 6.11. Flow Velocities and Shear Stress Close to the Wall at a Concave River Bank (Ligeng 1989).

$$\tau = \sqrt{\tau_z^2 + \tau_\theta^2} \quad (6.21)$$

where subscripts z and θ represent the vertical and the tangential coordinates of a cylindrical coordinate system. The longitudinal shear stress component can be found as

$$\tau_{\theta} = \rho g h S \quad (6.22)$$

where:

g = the acceleration of gravity

h = the local water depth

S = the water surface slope

The relationship between the shear stresses and the velocity components must satisfy

$$\frac{\tau_z}{\tau_{\theta}} = \frac{V_z}{V_{\theta}} \quad (6.23)$$

where V_z and V_{θ} are the vertical and tangential velocity components. According to [Rozovskii \(1961\)](#), [Eq. 6.23](#) has the following result:

$$\frac{\tau_z}{\tau_{\theta}} = k \left(\frac{h}{r} \right) \quad (6.24)$$

where:

k = constant

h = local water depth

r = radius of the channel bend

Combining [Eqs. \(6.20\)](#), [\(6.21\)](#), [\(6.22\)](#), and [\(6.24\)](#),

$$\frac{\partial y}{\partial t} = \frac{8\Phi}{\Delta^2 g} (\rho g h S)^{1.5} \left[1 + \left(k \frac{h}{r} \right)^2 \right]^{0.75} \quad (6.25)$$

[Eq. \(6.25\)](#) indicates that the bend expansion rate decreases with the bend radius and the expansion rate increases with water depth. So, the lower part of the side wall suffers heavier erosion than the upper. Consequently, an inverted bank slope can result. This could partly explain why the bend expansion is often accompanied by sudden bank collapse at river bends.

[Eq. \(6.25\)](#) still needs to be improved for two reasons: 1) the radius of channel bend cannot uniquely define a bend curvature, and 2) the channel slope (S) can change due to the bend expansion. By introducing a bend concavity parameter ([Figure 6.12](#)): $C = (b/a)$, the bend radius can be replaced by

$$r = \left(\frac{a}{2} \right) \left(\frac{1+C^2}{C} \right) \quad (6.26)$$

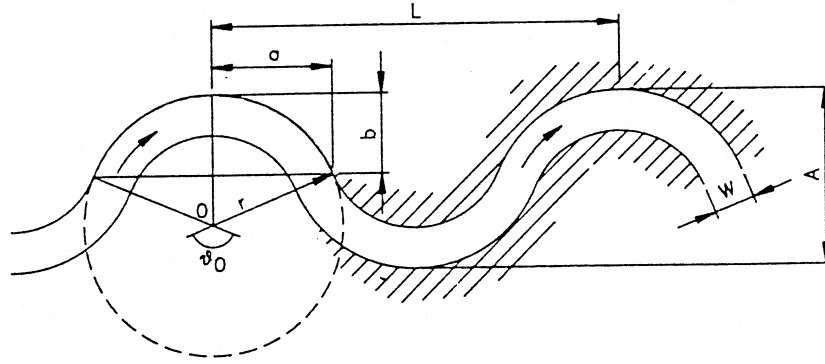


Figure 6.12. Geometric Relationships of a Meander Bend (Ligeng 1989).

The concavity can be calculated according to

$$C=2A/L \quad (6.27)$$

where:

- A (m) = meander amplitude
- L (m) = meander wave length

Accordingly, Eq. (6.26) can be changed into

$$r = \left(\frac{L}{8} \right) \left(\frac{1+C^2}{C} \right) \quad (6.28)$$

The channel slope along a bend is equal to $S = \delta H / (r\theta)$, where δH is the water level difference between the two end sections of a meander bend and is a constant; θ is the central angle of the bend in radians. It can be proved that $\theta = 2\pi - 4ctg^{-1}C$. Therefore, the channel slope may be expressed by the following equation:

$$S = 2S_i \left(\frac{C}{1+C^2} \right) \frac{1}{(\pi - 2ctg^{-1}C)} \quad (6.29)$$

where $S_i = 2(\delta H/L)$ is the meander valley slope. Substituting Eqs (6.28) and (6.29) into Eq. (6.23) and replacing the local water depth (h) by (H/2) in order to have the mean expansion rate (H= the water depth at the thalweg channel) the bend expansion rate is obtained as follows:

$$\frac{\partial y}{\partial t} = \Gamma \left[\left(\frac{C}{1+C^2} \right) \frac{1}{(\pi - 2ctg^{-1}C)} \right] \left[1 + K \left(\frac{C}{1+C^2} \right)^2 \right]^{0.75} \quad (6.30)$$

where:

$$\Gamma = \frac{8\Phi}{\Delta^2 g} (gHS_i), \text{ and } K = \left(\frac{4kH}{L} \right)^2$$

C (m/m) = bend concavity

g (m/s²) = acceleration due to gravity

H (m) = the water depth at thalweg channel

h (m) = local water depth

K = coefficient

k = a constant relating the ratio (h/r) with α , the deviation angle between the directions of the vertical and the tangential flow

L = (m): meander wave length

r (m) = radius of concave bend

S_i (m/m) = slope of the meander valley

t = time

ϕ = sediment transport coefficient for correcting the error due to using the bedload sediment transport formula for the wall

[Leopold and Wolman \(1960\)](#) found that the following relationships between the meander parameters held true:

$$L = 4.7 r^{0.98} \tag{6.31}$$

$$A = 2.7 W^{1.1} \tag{6.32}$$

where:

L (m) = meander wave length

A (m) = meander amplitude

r (m) = radius of curvature

W (m) = channel width

Substituting the above Eqs. (6.31) and (6.32) into the Eq. (6.27) we get:

$$C = 1.15 \left(\frac{r^{0.98}}{W^{1.1}} \right) \approx 1.15 \left(\frac{r}{W} \right) \tag{6.33}$$

where:

C (m/m) = bend concavity

r (m) = radius of curvature

W (m) = channel width

If the critical bend concavity is C=0.5-0.65, then the critical ratio (r/W) must be 1.8-2.3, which essentially agrees with the field observations by [Hickin \(1974\)](#) who suggested $(r/W)_{\text{critical}} = 2.1$

A distinctive feature of this formula is that it takes into account the vertical shear stress component induced by the helical flow, and the change in channel slope due to the bend expansion. It also offers a physical explanation to the bank collapse and to the maximum expansion rate of meander bends. The maximum bend expansion rate occurs when the bend

concavity is equal to 0.5-0.65. The bend expansion rate decreases with the bend radius. Hence a gentle channel bend is likely to be more stable than a sharp one.

6.23 MELVILLE, B. W., COLEMAN, S. E., 1999, “ BRIDGE SCOUR.”

Leopold and Wolman (1957, 1960) established a link between wavelength and channel width several orders of scale of flow in a variety of natural environments. Their equations were developed from meander characteristics of free-flowing regime channels as follows:

$$\begin{aligned}\lambda &= 11.0W^{1.01} \\ A &= 3.0W^{1.1} \\ \lambda &= 4.6R_c^{0.98} \\ R_c &= 2.4W\end{aligned}\tag{6.34}$$

where:

λ (m) = meander wavelength measured along the axis of the channel

W (m) = channel top width at the dominant discharge

A (m) = meander amplitude

R_c (m) = bend radius of curvature

Schumm (1968) analyzed large empirical data sets for sand bed channels in an attempt to account for the effect of boundary materials on meander wavelength explicitly by using a weight silt-clay index of the bed and bank sediments. The meander wavelength decreases as the proportion of fine material in the bed and banks increases.

$$\begin{aligned}\lambda &= 1982Q_m^{0.34}M^{-0.74} \\ \lambda &= 872Q_b^{0.43}M^{-0.74} \\ \lambda &= 666Q_{ma}^{0.48}M^{-0.74}\end{aligned}\tag{6.35}$$

where:

Q_m (m³/s) = mean annual discharge

Q_b (m³/s) = bankfull discharge

Q_{ma} (m³/s) = mean annual flood

M = percent silt-clay in the channel boundary

This indicates that the greater erosion resistance of silt-clay banks results in a narrow cross-section with steeper banks and tighter, shorter wavelength bends than those channels with non-cohesion or less cohesion.

Schumm (1968) also proposed a relationship between channel sinuosity and the weighted silt-clay index and the form ratio (width/depth) using the following:

$$\begin{aligned}
 P &= 0.94 M^{0.25} \\
 P &= 3.50 F^{-0.27}
 \end{aligned}
 \tag{6.36}$$

where:

P = planform sinuosity

F = width/depth ratio

These equations link the characteristic wavelength of meandering channels to the formative flow in the channel, its width, and the nature of the boundary materials.

The combination of the wavelength relations, width, and bend radius described above yields the following relationship:

$$R_c \approx 2 \text{ to } 3 W \tag{6.37}$$

Simon (1995) and Simon and Darby (1997) state that channel widening in association with degradation can be predicted based on bank stability analysis. Failure of the bank occurs when the bank height reaches a critical value h_c .

$$h_c = (c' / \gamma)(4 \sin i \cos \phi') / [1 - \cos(i - \phi')] \tag{6.38}$$

where:

h_c (m) = critical bank height

c' (kpa) = effective material cohesion

γ (kN/m³) = the bulk unit weight of the bank material

I (degree) = the angle of the bank surface

ϕ' (degree) = effective friction angle of the soil

where a tension crack is present for the bank, Simon and Darby (1997) indicate that the critical bank height is modified by the tension crack depth, z , to

$$\begin{aligned}
 h_{cz} &= h_c - z \\
 z &= (2c' / \gamma) \tan[45 + (\phi' / 2)]
 \end{aligned}
 \tag{6.39}$$

Alternative expressions for critical bank height are presented in Osman and Thorne (1988).

6.24 MOSSELMAN, E., CROSATO, A., AND HASEGAWA, K., 1991, "UNIVERSAL BANK EROSION COEFFICIENT FOR MEANDERING RIVERS."

The discussers think that it is important to distinguish between a bank erosion equation and a relation for the rate of bank migration. The former gives a local description of the removal of bank material by fluvial entrainment and mass failure as a function of near-bank flow conditions

and bank properties, whereas the latter describes the actual bank retreat, which is influenced by the interactions within the morphological systems. These interactions result from the fact that the near-bank conditions are in turn affected by the input of bank-erosion products and the changes of geometry due to bank erosion.

Bank migration rates depend directly on the absolute value of excess velocity u_B near the bank. The magnitude of u_B is determined not only by channel forms but also by the mean velocity u_0 , that can be expressed by formulas such as the Manning equation. If the nature of the bank soil does not change along the reaches of a river, the bank migration rates in the reach are affected by the local water depths and streamwise bed slopes, because mean and excess velocities depend upon them.

6.25 NAGABHUSHANAI AH, H. S., 1967, "MEANDERING OF RIVERS."

The necessary condition for the beginning of meandering of an alluvial channel is the transport of bed material. The most significant factors that influence meandering of an alluvial channel are valley slope, discharge, bed material, and time. The necessary condition for the origin and development of meander of an alluvial channel is the erosion of bed material and deposition of the eroded material downstream. The criterion for this development is that the discharge must be equal to or greater than the critical discharge. The relationship based on experimental results is:

$$\frac{M_w}{d_s} = 0.76 \left[\frac{(QS^2 - Q_c S^2)t}{d_s^3} \right]^{0.5} \quad (6.40)$$

where:

M_w (ft) = meander width

d_s (ft) = mean diameter of bed material

Q (cfs) = discharge

S (ft/ft) = longitudinal bed slope

Q_c (cfs) = critical discharge corresponding to critical shear velocity for median size of bed material

t = time

Here, the meander width is defined as the distance between lines drawn tangential to the extreme limits of the thalweg of fully developed successive meanders (Figure 6.13).

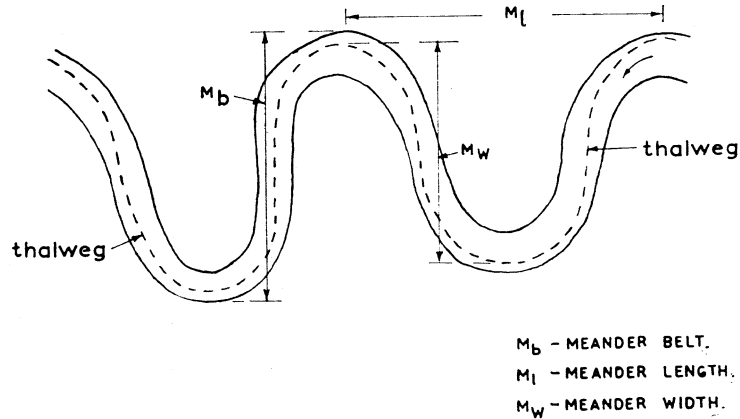


Figure 6.13. Definition Sketch of Meandering River (Nagabhushanaiah 1967).

Meanders in V-shaped channels start from the center (deepest point) of the channel and work inside the banks before they widen the banks. Meanders in rectangular channels start by widening the banks (outside meander). The meander width varies with $(Q - Q_c)^{0.5}$ for constant slope, time, and bed material. For very large discharges in flood flow, Q_c becomes insignificant, and the meander width increases with $Q^{0.5}$. Meander width increases with an increase in bed slope and time. The rate of meander reduces with the increase in bed material size. The meander development continues with time systematically and works towards an equilibrium condition. The sediment transport in the meandering channel decreases with time and tends towards constant value. Larger quantities of sediment are transported at increasing discharge and slope. Meandering can be attributed to the step taken by nature to decrease the excess slope of the channel by increasing the valley length through the development of a series of bends. The length of the thalweg increases with time until the channel ceases to meander and attains equilibrium. The time required to reach equilibrium may take longer when the discharge and slope increase and bed material size decreases.

6.26 NANSON, G. C., HICKIN, E. J., 1983, "CHANNEL MIGRATION AND INCISION ON THE BEATTON RIVER."

The radius of curvature of bends influences lateral migration rates of meandering rivers. This migration rate is normalized with respect to the channel width W (Figure 6.14). Normalized migration rates (MR/W) are highest when the radius of curvature-channel width ratio (R_c/W) is about 2.5, and they are lower when R_c/W is both higher and lower because of the lack of flow convergence and energy loss, respectively.

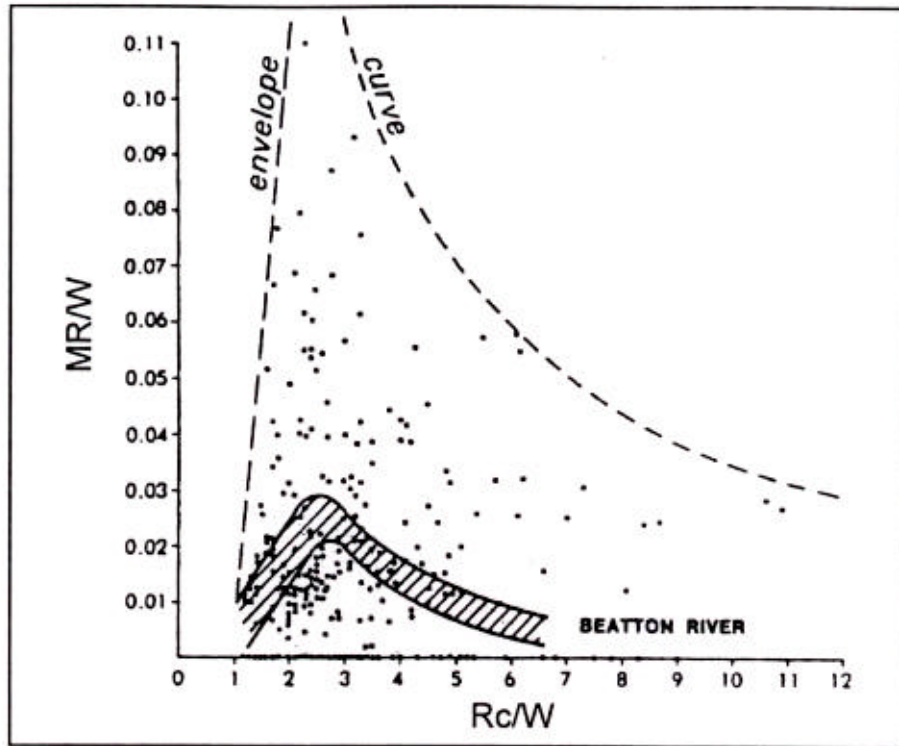


Figure 6.14. The Relation between Relative Migration Rates (after Nanson and Hickin 1983, 1986).

6.27 NANSON, G. C., HICKIN, E. J., 1986, "A STATISTICAL ANALYSIS OF BANK EROSION AND CHANNEL MIGRATION IN WESTERN CANADA."

Mean lateral migration rates for 18 meandering river channels in western Canada are explained statistically in terms of hydraulic and sedimentological variables. The volume of sediment eroded from the outer bank of a meander bend is shown to be largely a function of river size and grain size of sediment at the base of the outer bank. These variables explain almost 70 percent of the volumetric migration rate for these relatively large, sand and gravel-bed streams. Bank erosion and channel migration are probably largely determined by bed-material transport. It is for this reason that a simple relationship involving stream power and basal sediment size provides such an effective means of expressing the driving and resisting forces in this predictive model of channel migration. Indeed, recent work by Neill (1984) has shown that if flood-plain alluvium is differentiated into that derived from bedload versus that from suspended load, then bedload transport rates can be accurately predicted from measurements of lateral channel migration. Vegetation on the outer bank is seen to have little significant effect in controlling channel migration.

6.28 ODGAARD, A. J., 1987, "STREAMBANK EROSION ALONG TWO RIVERS IN IOWA."

In the past, several attempts have been made to relate the rate of bank retreat to channel characteristics to obtain an approximate relationship.

- [Brice \(1982\)](#): mean erosion rate in meters per year = 0.01 times channel width in meters.
- [Hooke's \(1980\)](#): mean erosion rate in meters per year = 0.05 times square root of drainage area in square kilometers.
- [Hickin and Nanson \(1975, 1984\)](#): channel curvature plays an important role in determining the rate of bank retreat.

$$\begin{aligned} v(\text{m/year}) &= 2.0b/r_c & b/r_c \leq 0.32 \\ v(\text{m/year}) &= 0.2r_c/b & b/r_c > 0.32 \end{aligned} \quad (6.41)$$

where:

V (m/year) = mean erosion rate
 b (m) = channel width
 r_c = radius of curvature

- [Ikeda et al. \(1981\)](#): their theory of river meanders assumes that the rate of bank retreat v is proportional to the difference between the near-bank depth-averaged mean velocity and the reach-averaged mean velocity at bank-full discharge.

The areal rate of erosion per bend A_e is obtained:

$$A_e = \bar{v} r_c \phi \quad (6.42)$$

where:

A_e (m²) = the areal rate of erosion
 \bar{v} (m/year) = average rate of erosion along eroding part of bank
 r_c (m) = radius of curvature of channel centerline
 ϕ = bend angle

6.29 SIDORCHUK, A., MATVEEV, B., 1997, "CHANNEL PROCESSES AND EROSION RATES IN THE RIVERS OF THE YAMAL PENINSULA IN WESTERN SIBERIA."

The variability of processes in channels and on flood plains in the valleys of the river Se-Yaha and the river Mordy-Yaha was investigated in connection with development of a natural gas field. Average rates of bank erosion and sediment accumulation in this little known region were determined from aerial photographs and radiocarbon and dendrochronological dating.

Short-term average rates of erosion were determined by the dendrochronological method. This method is based on the assumption that certain species of vegetation are gradually replaced with other ones as the flood plain grows in width and height due to flood sedimentation.

For convenience, remote-sensing evaluation of the rates of bank erosion in different parts of the area determined the maximum age of the grass flood plain, which is easily identified both on the aerial photographs and in the field. This age may be as constant for this limited area and can be determined by dividing the grass flood plain width by the average rate of growth. In turn, the

width of the dated grass flood plain on an accumulative bank is an excellent indicator of the rate of erosion of an opposite bank at the river reaches with relatively constant channel width. Thus the rate of erosion by radiocarbon dating can be verified by evaluation of the age of the grass flood plain at a number of points.

The cut-offs of single meanders cause substantial acceleration of the rate of channel deformation on a newly formed reach and adjacent channel forms.

6.30 THOMPSON, P. L., 1990, “APRIL 1989 HATCHIE RIVER U.S. 51 BRIDGE FAILURE.”

Spans of the northbound U.S. 51 Bridge over the Hatchie river collapsed on April, 1, 1989. Five vehicles went into the river, and eight people were killed as a result of the collapse. Lateral shifting of the channel, which undermined a bent, was identified as the cause for this disastrous failure.

This paper discusses the bridge site, field observations, stream stability, analysis of aerial photographs, model studies, and foundation analysis.

6.31 WILLIAMS, G. P., 1986, “RIVER MEANDERS AND CHANNEL SIZE.”

This study uses an enlarged data set to (1) compare measured geometry to that predicted by the [Langbein and Leopold \(1966\)](#) theory, (2) examine the frequency distribution of the ratio radius of curvature/channel width, and (3) derive 40 empirical equations (31 of which are original) involving meander and channel size features.

First of all, we need to know the nomenclature and data sources used here. The channel size consists of the bankfull width, W ; bankfull cross-sectional area, A ; and bankfull mean depth, D , defined as A/W . Meander features of interest ([Figure. 6.15](#)) are the wavelength, L_m ; bend length, L_b ; belt width, B ; radius of curvature, R_c ; and arc angle, θ . The data set, part of which comes from publications by other authors, consists of 194 sites from a large variety of physiographic environments in various countries, including the United States (114 sites), India and Pakistan (21 sites), Canada (21 Albertan sites), Sweden (17 sites), and Australia (5 sites). In data collecting, the three requirements were that (1) channels were alluvial, (2) sinuosities were ≥ 1.20 , and (3) the same measuring technique was used.

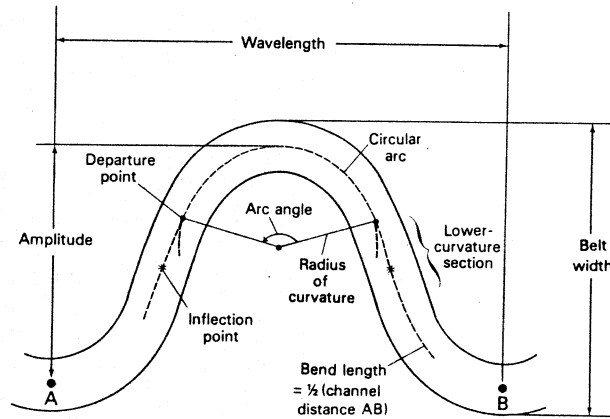


Figure 6.15 Plan-View Sketch of Idealized River Meanders (Williams 1986).

- (1) Comparison measured meander geometry to that predicted by the Langbein and Leopold (1966) theory.

Langbein and Leopold (1966) suggested that a sine-generated curve describes symmetrical meander paths. From this basis, they derived the relation:

$$R_c = \frac{L_m K^{1.5}}{13(K-1)^{0.5}} \quad (6.43)$$

in which K is channel sinuosity (ratio of channel distance to downvalley distance).

The above theory for predicting radius of curvature agrees very well with the field data in 78 sites and predicted versus observed R_c values are shown in Figure 6.16.

- (2) The frequency distribution of the ratio radius of curvature/channel width.

The frequency of distribution of the 79 available R_c/W values (Figure 6.17) is asymmetric. The computed geometric mean value of R_c/W is 2.43. The central two-thirds of the distribution lies between values of 1.6 and 4.4, and about one-third of the values are less than 2.0.

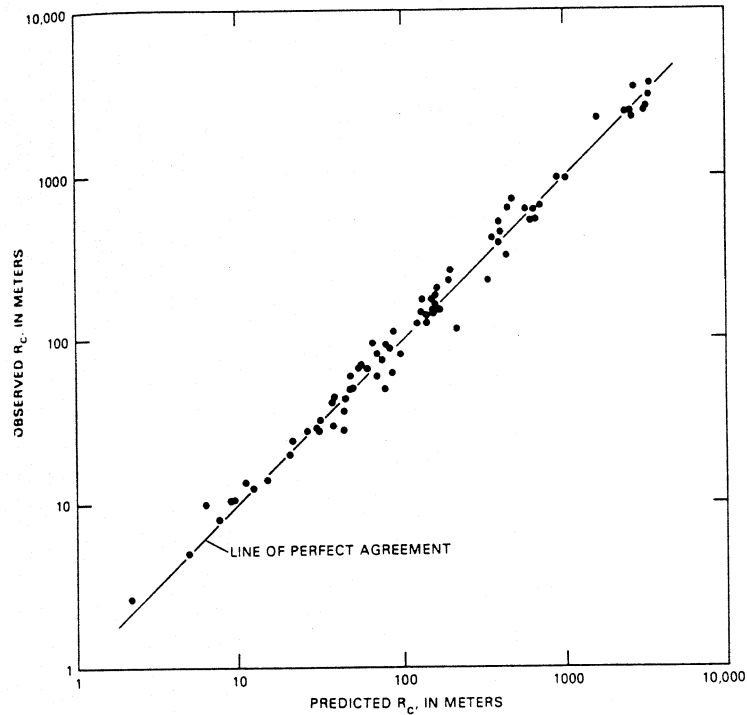


Figure 6.16. Observed Values of Bend Radius of Curvature versus Predicted by the Equation of Langbein and Leopold (1966).

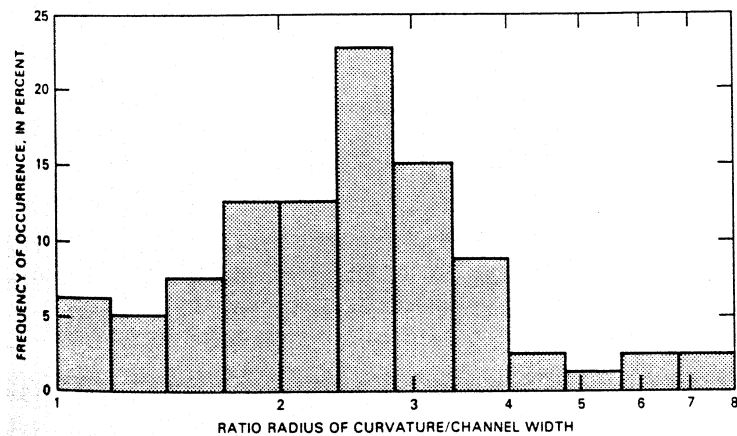


Figure 6.17. Frequency Distribution of R_c/W Values for 79 Streams (Williams 1986).

(3) 40 equations involving meander and channel size features.

With the 194 meander and channel size features data sets, 40 empirical equations were derived which are listed in Table 6.3. The 40 empirical relations, most of which include only two variables, involve channel cross-section dimensions (bankfull area, width, and mean depth) and meander features (wavelength, bend length, and belt width) which is shown in Figure 6.15. Of the 40 empirical equations, Figure 6.18 shows some typical plots.

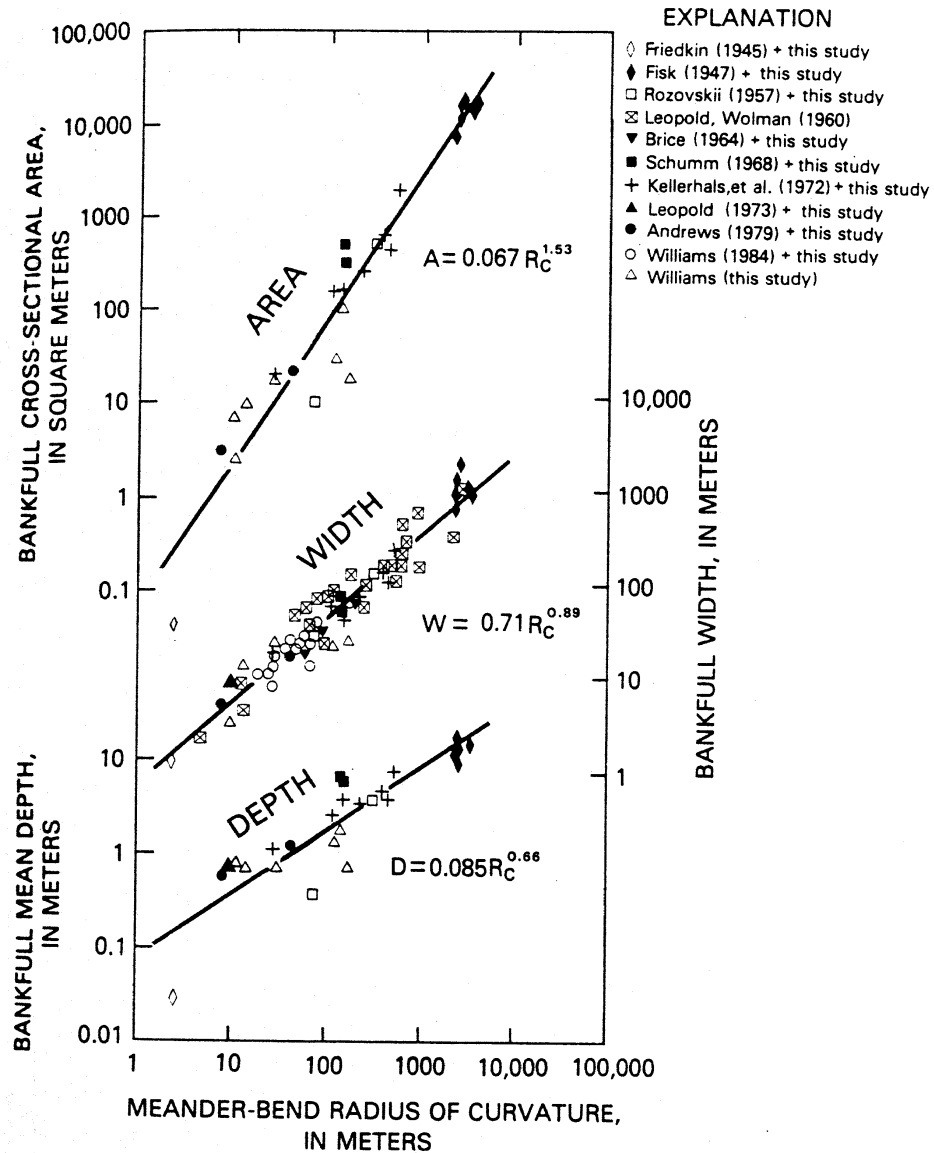


Figure 6.18. Meander Bend Radius of Curvature, in Meters (Williams 1986).

Table 6.3. Derived Equations For River-Meander and Channel Size Features.

Derived empirical equations for river-meander and channel-size features (A = bankfull cross-sectional area, W = bankfull width, D = bankfull mean depth, L_m = meander wavelength, L_b = along-channel bend length, B = meander belt width, R_c = loop radius of curvature, K = channel sinuosity, m = meters)

Equation number	Equation	Standard deviation of residuals, in percent		Sample correlation coefficient r	Number of data points	Applicable range
		+	-			
<i>Interrelations between meander features</i>						
2	$L_m = 1.25L_b$	32	24	0.99	102	$5.5 \leq L_b \leq 13,300 \text{ m}$
3	$L_m = 1.63B$	31	24	0.99	155	$3.7 \leq B \leq 13,700 \text{ m}$
4	$L_m = 4.53R_c$	21	17	0.99	78	$2.6 \leq R_c \leq 3,600 \text{ m}$
5	$L_b = 0.80L_m$	32	24	0.99	102	$8 \leq L_m \leq 16,500 \text{ m}$
6	$L_b = 1.29B$	31	24	0.99	102	$3.7 \leq B \leq 10,000 \text{ m}$
7	$L_b = 3.77R_c$	35	26	0.98	78	$2.6 \leq R_c \leq 3,600 \text{ m}$
8	$B = 0.61L_m$	31	24	0.99	155	$8 \leq L_m \leq 23,200 \text{ m}$
9	$B = 0.78L_b$	31	24	0.99	102	$5.5 \leq L_b \leq 13,300 \text{ m}$
10	$B = 2.88R_c$	42	29	0.98	78	$2.6 \leq R_c \leq 3,600 \text{ m}$
11	$R_c = 0.22L_m$	21	17	0.99	78	$10 \leq L_m \leq 16,500 \text{ m}$
12	$R_c = 0.26L_b$	35	26	0.98	78	$6.8 \leq L_b \leq 13,300 \text{ m}$
13	$R_c = 0.35B$	42	29	0.98	78	$5 \leq B \leq 10,000 \text{ m}$
<i>Relations of channel size to meander features</i>						
14	$A = 0.0054L_m^{1.53}$	103	51	0.96	66	$10 \leq L_m \leq 23,200 \text{ m}$
15	$A = 0.0085L_b^{1.53}$	140	58	0.95	41	$6 \leq L_b \leq 13,300 \text{ m}$
16	$A = 0.012B^{1.53}$	97	49	0.97	63	$5 \leq B \leq 11,600 \text{ m}$
17	$A = 0.067R_c^{1.53}$	138	58	0.97	28	$2 \leq R_c \leq 3,600 \text{ m}$
18	$W = 0.17L_m^{0.89}$	56	36	0.96	191	$8 \leq L_m \leq 23,200 \text{ m}$
19	$W = 0.23L_b^{0.89}$	56	36	0.97	102	$5 \leq L_b \leq 13,300 \text{ m}$
20	$W = 0.27B^{0.89}$	63	39	0.96	153	$3 \leq B \leq 13,700 \text{ m}$
21	$W = 0.71R_c^{0.89}$	48	32	0.97	79	$2.6 \leq R_c \leq 3,600 \text{ m}$

22	$D = 0.027L_m^{0.66}$	79	44	0.86	66	$10 \leq L_m \leq 23,200$ m
23	$D = 0.036L_b^{0.66}$	72	42	0.90	41	$7 \leq L_b \leq 13,300$ m
24	$D = 0.037B^{0.66}$	66	40	0.90	63	$5 \leq B \leq 11,600$ m
25	$D = 0.085R_c^{0.66}$	90	47	0.90	28	$2.6 \leq R_c \leq 3,600$ m

Relations of meander features to channel size

26	$L_m = 30A^{0.65}$	59	37	0.96	66	$0.04 \leq A \leq 20,900$ m ²
27	$L_b = 22A^{0.65}$	77	43	0.95	41	$0.04 \leq A \leq 20,900$ m ²
28	$B = 18A^{0.65}$	56	36	0.97	63	$0.04 \leq A \leq 20,900$ m ²
29	$R_c = 5.8A^{0.65}$	76	43	0.97	28	$0.04 \leq A \leq 20,900$ m ²
30	$L_m = 7.5W^{1.12}$	65	39	0.96	191	$1.5 \leq W \leq 4,000$ m
31	$L_b = 5.1W^{1.12}$	65	39	0.97	102	$1.5 \leq W \leq 2,000$ m
32	$B = 4.3W^{1.12}$	74	42	0.96	153	$1.5 \leq W \leq 4,000$ m
33	$R_c = 1.5W^{1.12}$	55	35	0.97	79	$1.5 \leq W \leq 2,000$ m
34	$L_m = 240D^{1.52}$	142	59	0.86	66	$0.03 \leq D \leq 18$ m
35	$L_b = 160D^{1.52}$	128	56	0.90	41	$0.03 \leq D \leq 17.6$ m
36	$B = 148D^{1.52}$	115	53	0.90	63	$0.03 \leq D \leq 18$ m
37	$R_c = 42D^{1.52}$	165	62	0.90	28	$0.03 \leq D \leq 17.6$ m

Relations between channel width, channel depth, and channel sinuosity

38	$W = 21.3D^{1.45}$	160	62	0.81	67	$0.03 \leq D \leq 18$ m
39	$D = 0.12W^{0.69}$	94	48	0.81	67	$1.5 \leq W \leq 4,000$ m
40	$W = 96D^{1.23}K^{-2.35}$	121	55	0.87	66	$0.03 \leq D \leq 18$ m and $1.20 \leq K \leq 2.60$
41	$D = 0.09W^{0.59}K^{1.46}$	73	42	0.86	66	$1.5 \leq W \leq 4,000$ m and $1.20 \leq K \leq 2.60$

7. PREDICTION OF STREAM BED DEGRADATION

7.1 BLENCH, T. 1969, “MOBILE-BED FLUVIOLOGY.”

The mean scoured flow depth, y_{ms} (m), below the free surface can be determined based on the mean discharge per unit channel width as:

for sand of $0.06 < d_{50}$ (mm) = 2

$$y_{ms} = 1.20 \left[\frac{q^{2/3}}{d_{50}^{1/6}} \right] \quad (7.1)$$

for gravel of $S_s = 2.65$ and $d_{50} > 2\text{mm}$

$$y_{ms} = 1.23 \left[\frac{q^{2/3}}{d_{50}^{1/12}} \right] \quad (7.2)$$

where:

q ($\text{m}^3/\text{s}/\text{m}$) = discharge per unit width

d_{50} (mm) = the sediment size for which 50 percent of the sediment is finer

Knowing the water surface level corresponding to q , the scoured bed level can then be determined. The resulting mean scoured bed level can then be modified for channel contraction, thalweg, bend, and confluence effects. Eq. (7.1) was derived for real in-regime canals of steady discharge, steady sediment-transport rate too small to appear explicitly in the equation, a dune sand bed of a natural particle size distribution and $0.1 < d_{50}$ (mm) = 0.6, suspended load too small to influence the equations, steep cohesive channel sides behaving as hydraulically smooth, channel straightness in plan so that the smoothed dune bed is level across the section, uniform channel slope and section, and constant water viscosity. This equation is indicated to apply satisfactorily to most well-maintained sand bed irrigation canal systems of width-to-depth ratios greater than about 5, and flow depths greater than about 0.4 m. Eq. (7.2) was derived based on large gravel rivers.

7.2 BRICE, J.C., 1982, “STREAM CHANNEL STABILITY ASSESSMENT.”

For engineering purposes, an unstable channel is one whose rate or magnitude of change is great enough to be a significant factor in the planning or maintenance of a bridge, highway, or other structure. Channel instability is manifested as progressive lateral migration (bank erosion), progressive vertical change in bed elevation (degradation, aggradation), or fluctuations in bed elevation about an equilibrium value with change in stage (scour and fill).

For the estimation of scour and other aspects of stream behavior, many engineers have evidently relied on engineering judgment, as based on prior experience and hydraulic analysis of flow. Channel stability assessment, by field observation and the interpretation of time-sequential airphotos, provides a further basis for decisions in site selection and bridge design.

A preliminary assessment of lateral stability, having a fair degree of reliability, can be made by the interpretation of channel properties visible on an airphoto made at or near normal stream stage. Streams having a uniform width and narrow point bars (equi-width streams) tend to be the most stable. Streams that are wide at bends and have wide point bars (wide-bend point-bar streams) tend to be less stable; the most unstable streams have wide point bars and are braided (braided point-bar streams).

Airphotos taken 20-30 years ago are available for most regions of the United States and comprehensive information on airphoto coverage is on file at the National Cartographic Information Center. Several techniques are suitable for measuring distance of lateral migration on time-sequential airphotos with accuracy sufficient for planning purposes.

Available measurements of bank erosion indicate that median erosion rate, in meters per year, tend to increase with stream size. The increase is directly proportional to the increase in stream width and to the square root of drainage basin area. For a given channel width, equi-width streams tend to have the lowest erosion rates, and braided point-bar streams the highest.

There is no consistent relation between degree of sinuosity (meandering) and degree of instability. Some equi-width streams having sinuosities in the range of 2 to 2.8 are among the most laterally stable of streams. Along an unstable stream, however, the instability occurs mainly at bends. Straight segments may remain stable for decades. The highest erosion index values were found for wide-bend or braided point-bar streams having sinuosities in the range of 1.2 to 2.

Channel degradation is a common cause of hydraulic problems at bridges in many regions of the United States. Most degradation is man-induced and results from the artificial straightening of long reaches of a channel, from sand-gravel mining, or from the closure of a dam. Past degradation is established by measurement of the change of streambed elevation in reference to a fixed datum, but the occurrence of degradation can, in many cases, be discerned from field evidence. The curve of cumulative degradation versus time is more likely to be asymptotic than linear. Equilibrium bed elevation is difficult to predict.

Natural scour and fill occurs by three different mechanisms, each of which can lower the local streambed elevation by an amount that is significant for the depth of pier foundations: (1) bed form migration; (2) convergence of flow, which is associated with scour at bends, pools, and channel constrictions, and divergence of flow, which is associated with fill at crossovers and riffles; and (3) shift of thalweg or braids within a channel. Sites having the greatest potential for natural scour can usually be identified from channel configuration and can therefore be avoided as crossing sites.

Scour by bed form migration is of consequence mainly in sand-channels. The height of dunes is typically about one-third of mean flow depth, and the passage of a dune results in scour to a

depth of about half dune height. The height of anti-dunes may approximate mean flow depth. Gravel bars are the typical bed forms of gravel bed streams, and their height mean flow depth. Bars tend to migrate on braided streams and remain fixed at riffles on unbraided pool and riffle streams. A migration gravel bar may concentrate flow at a bridge and cause local scour at piers or lateral bank erosion.

Scour by convergence of flow is related to channel configuration and is greatest at persistent deeps or pools in the channel long profiles, where the water velocity during floods is likely to be greatest. Such pools tend to occur at bends and to alternate with persistent riffles or crossovers. During a flood, the change in bed elevation at a pool tends to follow a trend that is a mirror image of the flood hydrograph, with scour on the rising stage and fill on the falling stage. At a crossover or riffle, the change in bed elevation tends to follow the hydrograph, with fill on the rising stage and scour (to preflood bed elevation) on the falling stage. Many cross sections along a stream are transitional between pools and riffles. In general, the scour induced by a bridge will be greater at pools or pool-like cross sections than at riffles or riffle-like cross sections.

Shift of the thalweg with increase in stage is a significant factor in bridge design, not only for estimation of the point of maximum bed scour (and bank erosion) but also alignment of piers with flood flow. Thalweg stability is related to channel stability and to stream type and can be assessed from aerial photographs.

7.3 BRICE, J. C., 1984, "ASSESSMENT OF CHANNEL STABILITY AT BRIDGE SITES."

Study of stream morphology on time-sequential aerial photographs provides information that is applicable to site selection and bridge design. By this means, information can be obtained on lateral stream stability, degradation, and natural scour and fill.

Lateral stability is related to stream type. Streams that have a uniform width and narrow point bars tend to be the most stable. Streams that have wide point bars and cut banks tend to be less stable and, for sinuous streams, stability tends to decrease with the degree of braiding. For a given stream type, median bank erosion rates tend to increase in direct proportion to stream size, as expressed by channel width.

Geomorphic factors relevant to site selection and bridge design are listed below in the form of questions. Exact answers to these questions can rarely be obtained, but even probable answers are worth considering.

1. Selection of Crossing Site

A. Site on a nonsinuuous reach

- i. Is site at a pool, riffle (crossover), or transition section?
- ii. Are alternate bars visible at low stream stage?
- iii. If mid-channels are present, what would be the effect of their migration through the bridge waterway?

iv. Is cutoff imminent at adjacent meanders?

B. Site at a Meander

- i. What has been the rate and mode of migration of the meander?
- ii. What is its probable future behavior, as based on the past?
- iii. Is site at pool, riffle, or transition section?
- iv. Is cutoff of the meander, or of adjacent meanders, probable during the life span of the bridge?

2. Design of Bridge

A. Piers on flood plain or adjacent to channel

Is the channel migration rate sufficient to overtake piers during the life span of the bridge?

B. Piers in channel

- i. For pier orientation, what is probable position of thalweg at design flood?
- ii. For scour estimation, what is probable bed form height at design flood?
- iii. For scour estimation, what is natural mean bed scour at design flood?
- iv. For scour estimation, what is lowest undisturbed streambed elevation at or near the crossing site?
- v. Does the stream have an unstable thalweg that has shifted with time?
- vi. Is there evidence of recent channel degradation?
- vii. Are any works of man in prospect that are likely to induce degradation of or bank erosion?

7.4 BROWN, S. A., 1982, "PREDICTION OF CHANNEL BED GRADE CHANGES AT HIGHWAY STREAM CROSSINGS."

It is important that grade-change predictions are based on more than one prediction technique or model and that the quantitative results are tempered by engineering judgment and experience. An appropriate solution procedure starts with the evaluation of geomorphic principles and relations (Lane's relations) to establish the cause and direction of the grade change. This can be built on by applying quantitative geomorphic and engineering relations (incipient motion consideration change in bed material volume, etc.) as well as relations developed for specific grade-change problems. When doing modeling, researchers should consider the level of analysis based on available time, manpower, and financial resources.

7.5 CLIFTON, A. W., KRAHN, J., FREDLUND, D. G., 1981, "RIVERBANK INSTABILITY AND DEVELOPMENT CONTROL IN SASKATOON."

This paper presents a history and description of the major slope failures which have occurred in the Saskatoon urban area, a discussion of the causes of instability, a review of stabilization techniques used, a summary of the responsibility and powers of the newly established river edge authority, and a discussion of public reaction to the authority.

Slope instability has been a problem in Saskatoon for a long time. The major factors are the soil stratigraphy and geology and the discharge of an urbanization-influenced surficial aquifer or a regional aquifer.

7.6 FRANCO, J. J., 1967, “EFFECTS OF STAGES ON SCOUR ALONG RIVERBANKS.”

Periodic surveys were made along several reaches of the Mississippi River through one high-water season to determine the effects of changes in river stages on depth of scour along concave riverbanks. The general conclusions indicated by the evaluation and analysis of available data is as follows:

- a) Either scour or fill can occur along a given riverbank during high flows, depending on the alignment and configuration of the river channel.
- b) The amount of scour or deposition along a given riverbank during high water appears to be more a function of stage duration than of the rate of change in stage.
- c) The location of the point of maximum scour or deposition can change in stage.
- d) In general, the effects of river currents on the stability of a riverbank are more a function of the alignment of the channel upstream, which affects the direction of currents toward the bank, than of the curvature or alignment of the bank.
- e) The relative effects of river currents on riverbank stability could be determined from a study of the alignment of currents approaching the bank from upstream during low and high stages, and/or by spot surveys to determine maximum depths along the bank near the start of the high-water season and one or two surveys during the high-water period.

7.7 GILJE, S. A., 1982, “STREAM CHANNEL GRADE CHANGES AND THEIR EFFECTS ON HIGHWAY STREAM CROSSINGS.”

Of data from 224 sites that were experiencing various hydraulic problems, thirty-nine (17.4 percent) had undergone changes in streambed elevation. Degradation is the lowering of a stream channel; therefore, a problem at a crossing is the exposure of footing, pilings, and foundations. Aggradation (general infilling of a stream channel) causes a reduction in the flow area available at crossings. In extreme cases, the flow area is less than that necessary for design discharges, which results in overtopping of the roadway or bridge deck. In the evaluations of highway problems, more than 80 percent of serious grade changes were caused by human intervention. Early recognition of degradation and aggradation requires:

- (1) Observation of stream characteristics.
- (2) Prediction of grade changes based on watershed activities.
- (3) Measurement of stream properties.

7.8 HOLLY, F. M., JR., NAKATO, T., KENNEDY, J. F., 1984, “COMPUTER-BASED PREDICTION OF ALLUVIAL RIVERBED CHANGES.”

The analysis and development of computer-based simulation techniques for alluvial riverbed evolution is used in the prediction of riverbed aggradation and degradation caused by perturbations in the river's equilibrium geometry and sediment inflow over extended reaches. In this paper the mathematical basis of the problem is reviewed and several general numerical approaches and associated difficulties are described. Seven published programs are then described, and their performance when applied to three actual field situations is compared.

The seven published programs are as follows:

1. Short-term Models:

- a) HEC2SR (HEC-2 with Sediment Routing),
- b) UUWSR (Uncoupled, Unsteady Water and Sediment Routing), and
- c) FLUVIAL-11.

2. Long-term Models:

- a) KUWASER (Known-Discharge, Uncoupled, Water and Sediment Routing),
- b) HEC-6 (Hydrological Engineering Center),
- c) CHAR II (Charriage dans les Rivieres), and
- d) IALLUVIAL (Iowa ALLUVIAL River Model).

The most important overall need is for better interpretation of physical processes and their incorporation in the numerical models. Improvement in model reliability requires further research in the areas described hereafter.

First, there is a strong need for a very reliable sediment transport relation because alluvial riverbed changes are the result of a streamwise gradient in the stream's sediment transport capacity.

Second, the bed-armoring process during channel degradation is not well understood and has not been adequately formulated in a conceptual model. Armoring and coarsening of the bed material size have a direct effect on the sediment transport capacity and the bed friction factor, and consequently affect the velocity, depth, and energy slope of the flow.

Third, there is a need to develop a better friction factor predictor that depends on flow depth and velocity and sediment discharge.

Fourth, there is a need to incorporate into models the bank erosion and channel migration effects of channel widening.

Fifth, there is a need for an effort to classify natural rivers in terms of their hydraulic and geomorphologic characteristics to guide engineers in the selection and application of a model that uses formulations of sediment discharge, channel roughness, channel widening, and so on that are most appropriate for their study cases.

7.9 JAIN, S. C., PARK, I., 1989, “GUIDE FOR ESTIMATING RIVERBED DEGRADATION.”

The objective of the paper is to present the results of numerical experiments in the form of algebraic relations that can be easily applied by practicing engineers to estimate the temporal and spatial riverbed degradation during the preliminary phase of the engineering designs. The bed profiles during riverbed degradation due to sediment interruption can be expressed in the form of a similarity profile, and the sediment diffusion coefficient of degradation depends significantly on time as well as the other three independent variables: Froude number, the initial normalized particle size, and the geometric standard deviation of the bed materials. The dependence on time of the diffusion coefficient is due to the armoring process.

7.10 JOHNSON, P.A., SIMON, A., 1995, “RELIABILITY OF BRIDGE FOUNDATIONS IN UNSTABLE ALLUVIAL CHANNELS.”

Channel-bed degradation can be described using a simple power relation of

$$E = at^b \quad (7.3)$$

where:

E (m) = channel bed elevation

t (year) = time

a, b = regression coefficients

Simon (1995) suggests that an exponential function provides a physical basis in describing aggradation and degradation, adopting

$$E / E_0 = a + be^{-kt} \quad (7.4)$$

where:

E_0 (m) = channel bed elevation at time t (year) = 0

K = regression coefficients (where a+b = 1)

For $E_0 > 0$ and $K > 0$,

a > 1 (relative bed level) and b < 0 (relative level change with time) : aggradation

a < 1 and b > 0 : degradation

7.11 LACEY, G., 1930, “STABLE CHANNELS IN ALLUVIUM.”

$$y_{ms} = 0.47 \left(\frac{Q}{f} \right)^{1/3} \tag{7.5}$$

where:

y_{ms} (m): mean scoured flow depth defined as the wetted area divided by the surface width
 f: the Lacey “Silt Factor” (Table 7.1)

Table 7.1. The Lacey “Silt Factor” f as a Function of Grain Size for Cohesionless Sediment (adapted from Indian Roads Congress 1966).

Mean Grain Size d_m (mm)	Lacey “Silt” Factor f^1
0.08	0.50
0.16	0.70
0.23	0.85
0.32	1.00
0.50	1.25
0.72	1.50
1.00	1.75
1.30	2.00

1. f can be described by $f = 1.76d_m^{0.5}$, where d_m is in millimetres

The method was designed for uncontracted sandy alluvial channels. Neill (1973) comments that f should normally be taken as 1.0 for sandy materials unless experience indicates otherwise. The formula is indicated to be equally applicable to alluvial rivers and tidal channels of sand beds, but it may give excessive depths in more resistant materials. Eq. (7.5) predicts the mean scoured flow depth across the uncontracted channel section. This can be modified for channel contraction, thalweg, bend, and confluence effects.

7.12 LAGASSE, P. F., SCHALL, F. J., RICHARDSON, E. V., 1999, “STREAM STABILITY AT HIGHWAY STRUCTURES.”

1. Incipient Motion

Incipient motion is the condition where the hydraulic forces acting on a sediment particle are equal to the forces resisting motion. The particle is at a critical condition where a slight increase in the hydraulic forces will cause the particle to move. The hydraulic forces consist of lift and drag and are usually represented in a simplified form by the shear stress of the flow acting on the particle. Incipient motion conditions can be analyzed using the Shields diagram or by the following equation developed from the diagram:

$$D_c = \frac{\tau}{K_s(\gamma_s - \gamma)} \quad (7.6)$$

where:

D_c (ft) = diameter of the sediment particle at the critical condition

τ (lb/ft²) = boundary shear stress

γ (lb/ft³) = specific weight of water

γ_s (lb/ft³) = specific weight of sediment

K_s = dimensionless coefficient often referred to as the Shields parameter

For sand sizes, the base value of Manning's n is representative of the grain resistance and the shear stress can be computed from:

$$\tau = \frac{\gamma n^2 V^2}{K^2 R^{(1/3)}} \quad (7.7)$$

where:

n = Manning roughness coefficient

V (ft/s) = average channel velocity

R (ft) = hydraulic radius

$K = 1.486$

For coarser grained materials (gravel and larger), the Manning roughness coefficient is a function of grain size and flow depth. The shear stress can be computed from:

$$\tau = \frac{\rho V^2}{\left[5.75 \log \left(\frac{12.27 R}{k_s} \right) \right]^2} \quad (7.8)$$

where:

ρ (slugs/ft³) = density of water

k_s (ft) = grain roughness usually taken as $3.5D_{84}$

2. Armoring

Armoring occurs when the hydraulic forces are sufficient to move a portion of the bed material but insufficient to move the larger sizes. Under these conditions, the smaller material is transported and removed from the bed leaving the coarse material or an armor layer.

The incipient motion equation can be used to determine the critical size of material that can resist a particular hydraulic condition. If at least five percent of the material is larger than the critical

size (D_{95} or smaller), armoring can occur. The following equation is used to predict the amount of degradation that would need to occur to form an armor layer:

$$Y_s = y_a \left(\frac{1}{P_c} - 1 \right) \quad (7.9)$$

where:

Y_s (ft) = depth of degradation or scour required to form the armor layer

y_a (ft) = thickness of the armor layer

P_c = percent of material coarser than the critical particle size expressed as a decimal fraction

3. Sediment continuity analysis

Sediment transport formulas are developed to predict bed load, suspended bed material load, or bed material load based on the sediment size and hydraulic conditions. “Highways in the River Environment” (Richardson et al. 1990) describes sediment transport processes, equations for predicting sediment transport, and recommendations on the selection of an appropriate equation.

The transport rates can be determined for a range of discharges and combined with a flow duration curve to determine the effective channel discharge. The sediment transport rates can also be summed for a specific flood hydrograph to predict single event aggradation or degradation.

The volume of material either eroded or deposited is:

$$\Delta V = V_{s(in\ flow)} - V_{s(outflow)} \quad (7.10)$$

where:

ΔV (ft³) = volume of sediment stored or eroded

$V_{s(inflow)}$ (ft³) = volume of sediment supplied to a reach

$V_{s(outflow)}$ (ft³) = volume of sediment transport out of a reach

The inflowing and outflowing sediment volumes are equal to:

$$V_s = q_s W \Delta t \quad (7.11)$$

where:

W (ft) = channel width

Δt (second) = time increment

Above **equation** can be summed over a hydrograph to determine sediment volumes during a flood event or can be combined with a flow duration curve to predict long-term rates. The amount of aggradation or degradation is then computed with:

$$Y_s = \frac{\Delta V}{WL(1-\eta)} \quad (7.12)$$

where:

η = porosity of the bed material

L (ft) = reach length

4. Equilibrium slope analysis

For the case of no sediment supply from upstream, combining the incipient motion relation and the Manning equation results in an estimate of the equilibrium slope where bed material movement ceases:

$$S_{eq} = \left[K_s D_c \left(\frac{\gamma_s - \gamma}{\gamma} \right) \right]^{(10/7)} \left(\frac{K}{qn} \right)^{(6/7)} \quad (7.13)$$

where:

S_{eq} = channel slope at which particles D_c will no longer move

Q (ft²/s) = channel discharge per unit width

Another approach to determining an equilibrium slope under conditions of no upstream sediment supply is presented by the U.S. Bureau of Reclamation ([USBR, 1984](#)) using the Meter-Muller equation for beginning of transport. If adjustment of the hydraulic depth due to the reduction in channel slope is included in the equation, the **USBR equation** is:

$$S_{eq} = K \frac{(D_{50})^{10/7} n^{9/7}}{(D_{90})^{5/14} q^{6/7}} \quad (7.14)$$

where:

$K = 28.0$ (SI)

$K = 60.1$ (English)

It is often useful to develop a sediment transport capacity relationship for a river reach in the form of:

$$q_s = aV^b Y^c \quad (7.15)$$

where:

q_s (ft²/s) = sediment transport capacity per unit width

V (ft/s) = channel average velocity

Y (ft) = channel average depth

a, b, c = coefficient and exponents

7.13 **LANE, E. W., 1957, "A STUDY OF THE SHAPE OF CHANNELS FORMED BY NATURAL STREAMS FLOWING IN ERODIBLE MATERIALS."**

Lane studied the changes in stream morphology caused by modifications of water and sediment discharges and developed simple qualitative estimate relationships among the most important variables indicating stream behavior. Similar but more comprehensive treatments of channel response to changing conditions in streams have been presented by [Leopold and Maddock \(1953\)](#), [Schumm \(1971\)](#), and [Santos-Cayado \(1972\)](#). All research results support the relationship originally proposed by Lane:

Lane's relation:

$$QS \propto Q_s D_{50} \quad (7.16)$$

where:

Q (m³/s) = water discharge

S (m/m) = channel slope

Q_s (m³/s) = sediment discharge

D_{50} (m) = median sediment size

7.14 **MONK, W. C., 1995, "JULY 1993 FLOOD DAMAGE TO U.S.71 BRIDGE OVER BRUSHY CREEK, CARROLL COUNTY, IOWA: CASE STUDY."**

The flood of 1993 inundated much of the upper Mississippi River Basin. Development of a computer flow model at the site and analysis of scour for the failed bridge and its replacement are included. On the basis of data from plans, topographic maps, and a United States Geological Survey (USGS) crest stage gauge at the site, the computer model was developed using WSPRO (a USGS/Federal Highway Administration (FHWA) computer program for Water Surface Profile Computations). The model was then used to estimate flood flows during the event. Scour was estimated using the WSPRO data and procedures from HEC-18. The computer program WSPRO and the scour procedures from HEC-18 are analysis tools that can be used to assess stream flows, scour potential, and design adequacy.

7.15 **ODGAARD, A. J., SPOLJARIC, A., 1989, "SEDIMENT CONTROL BY SUBMERGED VANES. DESIGN BASIS."**

Submerged vanes are small-aspect ratio flow training structures installed on the streambed, usually oriented at 10 to 20 degrees to the local primary flow direction. Vane height is typically 0.2 to 0.5 times the local water depth during design flow conditions. In curves of river channels, they eliminate the centrifugally induced secondary motion typical of flows in curved channel and the root cause of bank undermining. In shoaling channels, vanes generate a secondary motion, which redirects the sediment and provides depth control. The key to vane performance is the

horizontal force that they exert against water flow and its effect on near-bed flow and on circulation induced in flow downstream from vanes. These features determine the number and layout of vanes of a given design required to eliminate the problem of either bank erosion or shoaling.

7.16 ODGAARD, A. J., WANG, Y., 1990, “SEDIMENT MANAGEMENT WITH SUBMERGED VANES.”

Sediment control in rivers may be required for provision of greater channel capacity, maintenance of a certain optimum flow depth, improvement of nonregiment channels, prevention of bed and bank erosion, or for diversion of flow from one channel to another or to a water intake. Many different techniques are available for that. They range from construction of wing dams, jetties, dikes, and revetments to dredging. A major difficulty with these techniques is the lack of analytical tools for predicting their effectiveness and their impact on the channel. The design and layout of sediment control structures must often be based on physical model studies with the optimum solution being obtained by trial and error. Cost is a major design factor. Many of the standard control structures are expensive and often cannot be justified economically. Dredging is not always a desirable solution. This is due not only to cost but also to stringent regulation of spoil disposal and rapid exhaustion of acceptable disposal sites. The submerged vane technique appears to be a viable alternative to the traditional techniques. The effectiveness of the technique and its impact on the channel can be predicted. The cost of the technique compares favorably with that of the traditional technique.

Submerged vanes are small river training structures used for protection of streambanks against and for amelioration of shoaling problems in navigation channels, at water intakes, in bridge crossings, and at diversions. The submerged vane technique has merits as a general sediment control technique for rivers. By generating secondary circulation in the flow, the vanes alter the distribution of bed shear stresses across the river channel and cause a redistribution of flow velocity and depth.

7.17 RICHARD P., GEORGE, T., 1999, “CAESAR: AN EXPERT SYSTEM FOR EVALUATION OF SCOUR AND STREAM STABILITY.”

The primary purpose of this software (CAESAR) is to aid field inspectors in the inspection of bridges with respect to scour and stream stability and then provide conclusions about the scour process. The 25 case studies represent bridges experiencing a wide variety of scour risks, and CAESAR produced results identical to those of the scour experts.

7.18 RUS, DAVID L., SOENKSEN, PHILIP J., 1998, “CHANNEL STABILITY OF TURKEY CREEK, NEBRASKA.”

Simon (1994) found that changes in streambed elevation over time can be simulated by a power-decay equation. A modified version of that equation follows:

$$E = E_0(t - t_0)^b \quad (7.16)$$

where:

E (m) = elevation of the streambed for a given year, in meters above sea level
 E_0 (m) = elevation of the streambed prior to the episode of gradational change, in meters above sea level
 t = year
 t_0 = year prior to that start of gradation change process
 b = dimensionless exponent representative of the nonlinear rate of change of streambed, determined by power regression.

An important component of this equation was the nonlinear rate of change, b . If the streambed is aggrading, then b is positive; if it is degrading, then b is negative. Drees and others (1996) reported a series of nickpoints, and an abrupt change in slope in the Turkey Creek Basin. It is reasonable to assume that nickpoints will migrate upstream throughout the basin and cause further degradation and bank widening. Gradational processes have already caused problems in the Turkey Creek watershed, and will continue to do so. For example, degradation has exposed the footings of the bridges at the middle site. Channel widening also has caused agriculture land loss adjacent to the creek and may threaten more bridges by exposing and even undermining bridge abutments. The increased sediment load from degradation and channel widening will continue to be deposited in lower reaches of the stream. The deposition will increase the likelihood of flooding and also can reduce the expected life of reservoirs. This deposition may indicate the beginning of destabilization, although more degradation can still occur if the slope of the streambed downstream of the aggraded reach becomes sufficiently steep.

7.19 SCHALL, J. D., LAGASSE, P. E., 1991, "STEPWISE PROCEDURE FOR EVALUATING STREAM STABILITY."

The purpose of this paper is to outline a stepwise analytical procedure for evaluation of stream stability.

1. Level 1: Qualitative and other geomorphic analysis.

Step 1: Define stream characteristics.

Step 2: Evaluate land use changes:

- 1) the relationship or correlation between changes in channel and
- 2) stability and land use can contribute to a qualitative understanding of system response mechanism.

Step 3: Assess overall stream stability.

Step 4: Evaluate lateral stability:

- 1) field inspection,
- 2) aerial photographs or maps, and
- 3) Surveyed cross sections.

Step 5: Evaluate vertical stability:

- 1) degradation,
- 2) aggradation – increases the frequency of backwater that can cause damage, and
- 3) data records are needed to detect gradation, including historic streambed profiles and long-term trends in stages – discharge relationships.

Step 6: Evaluate channel response to change.

2. Level 2: Basic engineering analysis,

Step 1: Evaluate flood history and rainfall (runoff relations and the study of wet-dry circles).

Step 2: Evaluate hydraulic conditions.

Step 3: Bed and bank material analysis:

- bed material size > bank material size and
- tributary sediment characteristics.

Step 4: Evaluate watershed sediment:

- The physical processes causing erosion can be classified as sheet erosion, rilling, gullying and channel stream erosion.
- Use Regression equation (universal soil loss equation).

Step 5: Incipient motion analysis:

- The hydrodynamic forces acting on the sediment

Step 6: Evaluate armoring potential.

Step 7: Evaluation of rating curve shifts:

- An analysis of stage-discharge rating curve shift over time can provide insight on stream stability. The most common causes of rating curve shifts in natural channel control sections are generally scour, and fill, and channel width.

Step 8: Evaluate scour conditions.

7.20 SHERRILL, J., KELLY, S., 1992, “ USING SCOUR AND STREAM INSTABILITY EVALUATIONS TO INCREASE BRIDGE SAFETY.”

Scour can occur as a combination of three components; general or contraction scour, abutment scour, and pier scour.

Increased velocities and sediment transport of the water flow over a period of time can create changes in vertical or horizontal cross-sections. These changes result in stream instability, commonly referred to as erosion. Vertical changes refer to the increase (aggradation) or decrease

(degradation) in channel bed elevation over time. Horizontal changes in a channel cross section at a site, such as bank cutting and meandering, are referred to as lateral instability.

FHWA requires inspection of the 577,000 bridges on the national inventory at regular intervals not to exceed two years. Bridges with underwater members that cannot be visually evaluated during low-flow periods are required to be inspected by divers at least every five years.

Several types of countermeasures can be introduced including sheet piling, riprap, and precast interlocking concrete blocks as a result of routine field inspections.

The added cost of making a bridge less vulnerable to scour or stream instability is small when compared to the total cost of a failure, which can easily be two or three times the original cost of the bridge.

7.21 SONI, J. P., KUMAR, N., 1980, “EVALUATION OF FRICTION FACTOR IN AGGRADING AND DEGRADING ALLUVIAL CHANNELS.”

Non-uniform and unsteady flow conditions prevail during aggradation and degradation processes occurring in alluvial channels. In mathematical modeling of such processes, the value of the resistance coefficient is assumed to be constant at its uniform value. To check the validity of such an assumption and to improve physical understanding of these processes, the variation of the friction factor f and Manning’s coefficient n has been studied using the experimental data of Soni (1975, 1978, 1982) and Suryanarayana (1969) for aggradation and degradation respectively.

$$\frac{n}{n_0} = \left(\frac{G}{G_0} \right)^{1/2} \left(\frac{h}{h_0} \right)^{5/3} \quad (7.17)$$

$$\frac{f}{f_0} = \left(\frac{G}{G_0} \right) \left(\frac{h}{h_0} \right)^3 \quad (7.18)$$

where:

n_0 and n : Manning’s coefficient for uniform and non-uniform flow respectively

G_0 and G ($m^3/s/m$): sediment transport rate in absolute volume per unit width per second for uniform and non-uniform flow respectively

h_0 and h (m) : mean flow depth for uniform and non-uniform flow respectively

At any time for a run, the values of n/n_0 and f/f_0 were computed for various distances along the aggraded reach.

From the present study, the following conclusions can be drawn:

1. Aggradation: for low rates of overloading, the maximum decrease in the value of f and n is 36 percent and 25 percent respectively; whereas for higher rates of overloading the maximum increase in the values of f and n is 72 percent and 25 percent respectively.
2. Degradation: the maximum decrease in value of f and n is 74% and 46% respectively.
3. Manning's roughness coefficient is a better parameter to be used in the mathematical modeling of alluvial channels because its variation over the aggraded/degraded reach is relatively smaller than the variation of f , and the assumption of taking n as constant would introduce a smaller error.

7.22 TRENT, R. E., BROWN, S. A., 1984, "AN OVERVIEW OF FACTORS AFFECTING RIVER STABILITY."

Recognizing and anticipating channel instabilities is an important part of locating and designing highways in river environments. Channel instabilities included oscillations in channel bed elevation, variations in river orientation and location, and major river migrations or meanders. Factors affecting river stability are classified as natural or accelerated. Natural instabilities result from changes in hydrometeorology whereas accelerated erosion is usually a result of man's activities within the watershed.

Identifying channel instabilities requires an understanding of the geomorphic processes occurring within the watershed in question and an awareness of all activities that affect stability. A thorough analysis of system stability should include consideration of system change and changes in progress, as well as a geomorphic analysis to predict future changes.

7.23 WEBER, L. L., 1996, "CHANNEL SCOUR PROTECTION AT ROADWAY CROSSINGS."

Conditions could be defined under which a nonerodible channel slope (as defined by perhaps a flow velocity less than 1.5 m/s for a sand bed or incipient motion for larger particles) may be applied to obtain riverbed lowering due to general degradation. The need to carry out such simplified analysis is particularly evidenced for small projects for which the application of complicated and comprehensive analyses may not be economical.

7.24 YANG, X., MCVEY, M. J., MORRIS, L. L., BAUMEL, C. P., 1995, "IMPACT OF STREAM DEGRADATION ON BRIDGES AND RURAL TRAVEL PATTERNS."

Many streams throughout Iowa were channelized to reduce flooding and to open more land to farming. Channel straightening accomplished this goal, but led to greater stream flow velocities, causing degradation on stream channels. This widening and deepening of streams resulted in damage to rural roads and bridges. This paper primarily describes a method to allocate limited funds to various bridge projects using benefit cost analysis and benefit cost ratio which consider costs for traffic rerouting, bridge maintenance, and reconstruction. And then the mixed integer programming (MIP) model was developed to maximize the total social benefit of all the county bridges subject to the budget constraint of a local government.

8. COUNTERMEASURES

8.1. INTRODUCTION

The survey of DOT and FHWA engineers revealed that the most preferred design guideline for the design of stream instability countermeasures is HEC-23 of FHWA (Publication No. FHWA HI 97-030, July 1997). To a much lesser extent, AASHTO (American Association of State Highway and Transportation Officials) manual (AASHTO hydraulic drainage manual, 1992 and AASHTO model drainage manual 1992) is also used. Some other agencies use other guidelines and/or guidelines developed by themselves. Among these HEC-23 is so far the most comprehensive. Yet this is not a complete solution to all the problems related to stream degradation and migration. This will be discussed in detail in the following.

The first edition of HEC-23, published in July 1997, is the current one. The second edition is currently under development and a draft copy was made available to us (courtesy of Mr. Peter Lagasse at Ayres Associates and Mr. Jorge Pagan-Ortiz at FHWA). Basically HEC-23 is the collection of design guidelines and general information about common stream instability countermeasures used in various parts of the country. It presents in matrix form various features of available countermeasures in terms of functionality, suitability, maintenance, and experience of different states. It also gives the relevant references in this connection.

The matrix gives information about fifty different types of countermeasures including monitoring measures. Of these fifty countermeasures, it is reported that Texas has experience of twenty-eight types.

The first edition of HEC-23 presents design guidelines for only eight types. The second edition (draft copy) includes fifteen types along with some case studies. These guidelines are basically collected from different state organizations. Most of the countermeasures do not have any well-documented guidelines available at all.

The design procedures outlined in HEC-23 have been developed through experience and trial and error methods. It is pointed out that while some countermeasures are successful in some areas, they are reported to have failed in other areas of different geomorphic and hydraulic conditions. Some of the successful countermeasures are not necessarily well known.

A numerical simulation of the physical processes involved in stream degradation and meander migration and in the interaction between the active channel and the countermeasure would give more insight about what is going on in the field. It would also be used to develop more rigorous sets of equations to be incorporated in a design procedure.

8.2. COUNTERMEASURES CLASSIFICATION

There is a full range of available countermeasures that are suitable for different situations. Proper classification is required to understand each one of them and to develop selection criteria. Countermeasures are classified as follows:

- **Flexible revetments or bed armor**

Dumped rock riprap, rock-and-wire mattresses, gabions, car bodies, planted vegetation, precast-concrete blocks, willow mattresses.

- **Rigid revetments or bed armor**

Concrete pavement, sacked concrete, concrete-grouted riprap, concrete-filled fabric mats, bulkhead.

- **Flow-control structures**

Spurs, retards, dikes, spur dikes (guide banks), check dams, jackfields, bendway weirs, hardpoints.

- **Special devices**

Drift deflectors, abrasion armor at pier nose, bulkheads.

- **Modifications of bridge, approach roadway, or channel**

Underpinning or jacketing of pier, construction of outflow section on roadway, realignment of approach channel.

- **Measures incorporated into design of a replacement bridge**

Increased bridge length, fewer or no piers in channel.

The countermeasures that are used to arrest or retard meander migration are spurs, dikes, riprap, concrete pavements, bulkheads, guide banks, and jackfields. These are discussed in the following section with respect to design principle, use, and success and failure rate. After that discussion, countermeasure case histories from [Brice and Blodgett \(1978\)](#), [Brice \(1984\)](#) and [Brown \(1985\)](#) are presented.

8.3 REVETMENTS

Revetments are layers of erosion resistant materials that are laid at the water-soil interface on the embankment or streambank. They aim at protecting against horizontal migration of the channel. They do not alter the flow or the channel characteristics. This type of countermeasure is usually not used for degradation problems, unless specially designed for that purpose.

Revetments provide protection against erosion. They do not protect against slumping of the saturated streambank or embankments or against any other geotechnical problem in the underlying soil.

Revetments can be flexible or rigid. Flexible revetments include rock riprap, wire enclosed rock mattresses, gabions, precast concrete blocks, rock fill trenches, windrow revetments, used tire revetments, and vegetation. Flexible mattresses have the ability to adjust to a change in the ground surface due to any settlement in the underlying soil and thus retain its integrity.

Rigid revetments include concrete pavement, sack filled with soil/cement, soil cement, and grouted or partially grouted rock riprap.

Rigid revetments are highly resistant to erosion and impact. They are smooth and pleasing to see. But they are very costly. They are susceptible to damages due to foundation subsidence, undermining, hydrostatic pressure, slides, and erosion at the edges.

The only revetment which has a design procedure is riprap. The design simply consists of determining the size of rock that will withstand the adverse effects of flow in the extreme conditions.

8.3.1 Flexible Revetments

8.3.1.1 Riprap

Riprap is the most common measure of scour protection. Riprap is generally flexible revetment of large stones placed on the bank, streambed, and/or around pier abutments, etc. They may be wire enclosed, in wire baskets (gabion), or may be made of concrete blocks of various shapes and sizes. They may also be made of windrow or tire revetment and may include vegetation. Successful designs include proper filter design beneath the riprap and an edge treatment above the erodible soil.

The most important design feature is the size of the stone. The main design parameter is the stream velocity and its tractive force. Other parameters include soil angle of repose, depth of flow, flow variation, bend curvature, streambank slope, etc.

The necessary formula and design charts are provided in the manual HEC-23. The design procedure also includes filter design and edge treatment procedures. The filter design addresses the characteristics of the soils to be protected. The procedure to solve the problem of edge treatment is discussed in qualitative terms. Dumping is the most commonly used method of installation but not necessarily the most appropriate.

Riprap is generally successful. But failures are also reported. In HEC-23, it is reported that a study of 58 sites of stone riprap countermeasures, 34 were satisfactory, 12 were partially satisfactory, and 12 failed to perform satisfactorily. The causes of these 12 failures are varied. Among the causes are inadequate filter layer beneath the riprap and bank slope failure. One site with old cars used as the material for riprap could not prevent the slumps in high fills. Inadequate

rock size and size gradation was reported to be the cause for eight failures. Causes can also be of a geotechnical nature. For example, size determined by existing formulas based mainly on stream velocity was inadequate. The complexity of a site is not properly addressed in the current method. A numerical simulation method may provide better insight into the complex phenomena and may help develop a better set of formulae.

8.3.1.2 Wire Enclosed Riprap

Wire enclosed riprap is used when the available stone size is small. This flexible revetment is usually not as thick as conventional stone riprap revetment and is enclosed in a wire mesh (gabion boxes). These gabions are stacked up to provide scour protection (Figure 8.1).

The design features include thickness, slope angle, type, shape and material of wire mesh, placement, anchoring, and splicing. A design chart is provided in HEC-23 for selecting required type and dimensions. There is no mention of flow or soil characteristics.

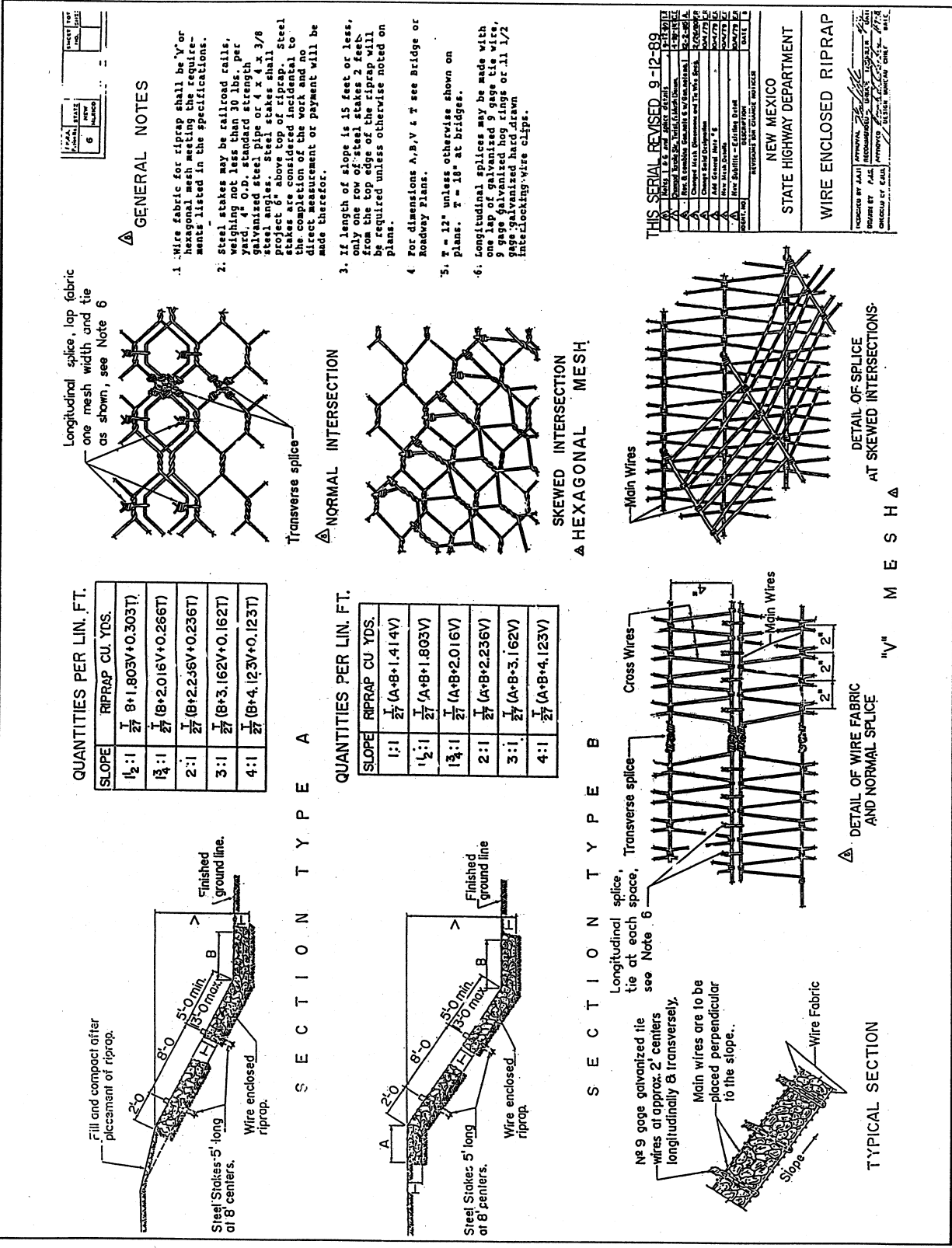
The main reason for failure of wire-enclosed riprap is probably the weathering of the wire itself. No case history is reported in HEC-23 for the success or failure rate of this type of countermeasure.

8.3.1.3 Articulated Concrete Block System

Articulated concrete block systems (ACBs) are used for scour protection in banks, bridge abutments, bed armoring, and local pier scour. These concrete blocks are held together by interlocking and/or steel cables or rods. The cable tied ones are more common. They are placed to form a flexible mat or blanket.

The design method is based on the determination of the factor of safety for a single block against failure. Failure is defined as the loss of contact between the bottom of the block and the subgrade. Rigorous formulae are provided in HEC-23 and in the literature. Design charts and examples are also provided. These include flow parameters but apparently do not include sub-soil parameters. However HEC-23 observes that failure can be initiated due to subgrade material loss by piping, washout, liquefaction and geotechnical slope failure; these are directly related to soil parameters.

Design guidelines for ACBs for pier scour and as seal around piers are also included in the HEC-23.

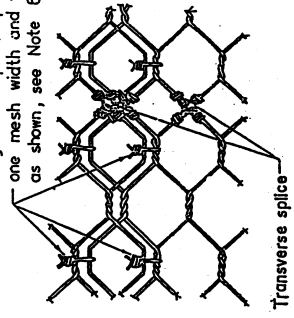


SECTION NO.	6
DATE	REVISED
BY	
APPROVED BY	

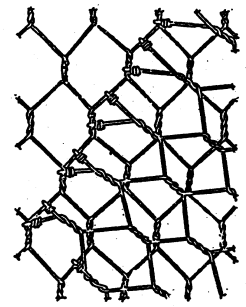
GENERAL NOTES

- Wire fabric for riprap shall be "Y" or hexagonal mesh meeting the requirements listed in the specifications.
- Steel stakes may be railroad cable, weighing not less than 30 lbs. per yard, 4" O.D. standard strength galvanized steel pipe or 4 x 4 x 3/8 steel angles. Steel stakes shall project 6" above top of riprap. Steel stakes shall be spaced incidental to the completion of the work and to direct measurement or payment will be made therefor.
- If length of slope is 15 feet or less, only one row of steel stakes 2 feet from the top edge of the riprap will be required unless otherwise noted on plans.
- For dimensions A, B, V & T see Bridge or Roadway Plans.
- T = 12" unless otherwise shown on plans. T = 18" at bridges.
- Longitudinal splices may be made with one lap of galvanized 9 gage tie wire, galvanized hog rings or 1/2" interlocking wire clips.

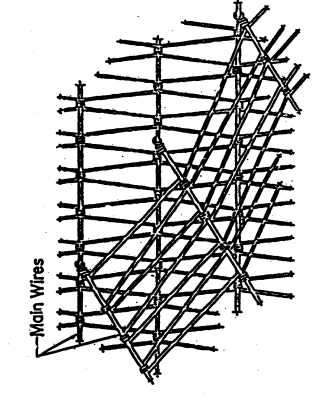
Longitudinal splice, lap fabric one mesh width and tie as shown, see Note 6



NORMAL INTERSECTION



SKEWED INTERSECTION



DETAIL OF SPLICING AT SKEWED INTERSECTIONS

WIRE ENCLOSED RIPRAP

THIS SERIAL REVISED 9-12-89

REVISION	DATE	BY	CHKD.
1	11-11-89		
2	12-12-89		
3	12-22-89		
4	12-22-89		
5	12-22-89		
6	12-22-89		
7	12-22-89		
8	12-22-89		
9	12-22-89		
10	12-22-89		
11	12-22-89		
12	12-22-89		
13	12-22-89		
14	12-22-89		
15	12-22-89		
16	12-22-89		
17	12-22-89		
18	12-22-89		
19	12-22-89		
20	12-22-89		
21	12-22-89		
22	12-22-89		
23	12-22-89		
24	12-22-89		
25	12-22-89		
26	12-22-89		
27	12-22-89		
28	12-22-89		
29	12-22-89		
30	12-22-89		
31	12-22-89		
32	12-22-89		
33	12-22-89		
34	12-22-89		
35	12-22-89		
36	12-22-89		
37	12-22-89		
38	12-22-89		
39	12-22-89		
40	12-22-89		
41	12-22-89		
42	12-22-89		
43	12-22-89		
44	12-22-89		
45	12-22-89		
46	12-22-89		
47	12-22-89		
48	12-22-89		
49	12-22-89		
50	12-22-89		

REVISIONS FOR CHANGE NOTICE

NEW MEXICO
STATE HIGHWAY DEPARTMENT

WIRE ENCLOSED RIPRAP

APPROVED BY: [Signature]
DATE: [Date]

RECOMMENDED BY: [Signature]
DATE: [Date]

DESIGNED BY: [Signature]
DATE: [Date]

CHECKED BY: [Signature]
DATE: [Date]

Figure 8.1. Design Figures for Wire Enclosed Riprap (Lagasse, 1997).

8.3.1.4 Concrete Armor Units

Concrete armor units are man-made three-dimensional shapes that are used instead of stones. These are used where extreme hydraulic conditions require the use of a large stone size that is not economically available. These concrete armor units are designed to have interlocking capacity and overturning resistance. They have been used at shorelines, channels, streambanks and bridge sites. They are used to prevent lateral migration and local scour around piers and abutments.

The principal design consideration is the stability of individual armor units against the most severe hydraulic conditions. There are several types of armor units with different patented names. The design criteria are almost the same for all. Design criteria include stability analysis based on Isbash Stability Number, Shields Parameter, and Froude Number.

HEC-23 provides a detailed design procedure along with an example for armor units called Toskanes. The design uses flow velocity, channel dimension, size, shape, and material property of armor unit but no soil parameter.

8.3.1.5 Grout/Cement Filled Bags

Engineers use cement/grout filled bags as a replacement for riprap when suitable quality and size of rock is not found economically. Grout/cement can be used both for lateral instability problems and degradation problems. These are used to fill the undermined areas of bridge piers and abutments after actual scour has taken place.

These are individual bags or sacks filled with grout or concrete which are generally not tied to one another. They are supposed to act as discrete blocks against failure. There is no rigorous design procedure reported in the HEC-23. General guidelines and specification as to size, shape, and material properties are available.

The main mechanism of failure is once again undermining. Cutoff walls or anchoring are used against undermining. In bank protection works, adequate filter design has to be incorporated.

8.3.1.6 Rock Riprap at Pier and Abutment

Rock riprap at the pier or abutment is used to stop vertical degradation and local scour at those locations.

The principal design requirement is to determine the stone size, which would not be moved under a severe flow condition, and the extent of riprap. The design parameters include velocity and depth of the flow, Froude number, pier/abutment dimensions, and properties of the rock riprap, etc. The underlying soil properties are not included in the design parameters. But HEC-23 reports that deformation and leaching out of the soil beneath may have considerable effect on the performance of the riprap; again properly designed filter can help in this case.

HEC-23 design procedure is still in need of improvement, and FHWA is conducting research to find out the best design procedure for rock riprap at pier and abutments. The present design procedure is based on laboratory projects without field verification. It is found that failure does

not occur due to a single storm. Therefore it is recommended that the bridge should be monitored after each high flood.

HEC-23 reports that the reason for the failure of the Schoharie Creek Bridge on I-90 at Albany near New York was due to the removal of stone riprap at the base of the pier.

8.3.1.7 Used Tire Revetment

Revetment made of used tires (Figure 8.2) is used for low velocities and mild bends. Used tires, tied with each other, are placed along the slope of the bank, and the edges are tied to the ground by means of anchors. This type of revetment can accommodate bank subsidence to some extent, but will be damaged if subsidence is considerable. This countermeasure is very susceptible to edge undermining. Therefore some other type of apron, such as rock riprap or gabion, is needed. This countermeasure is also susceptible to vandalism. Construction is labor-intensive, hence costly.

HEC-23 provides qualitative guidelines for the design of used tire revetment. No formulae or design chart is provided. The guidelines say that the tires must be tied to one another and to all edges firmly. Alternatively, tires can be woven by cables running through the length and width. To avoid floatation of the tires, they may be cut and drilled full of burnt holes in the sidewall. The sizes should be sorted so as to produce a close-fit mattress. The tires may be packed with stones or rubble. Also willow or other suitable type of vegetation growth can provide greater stability, reduce flow, induce deposition, and thus achieve a stable channel.

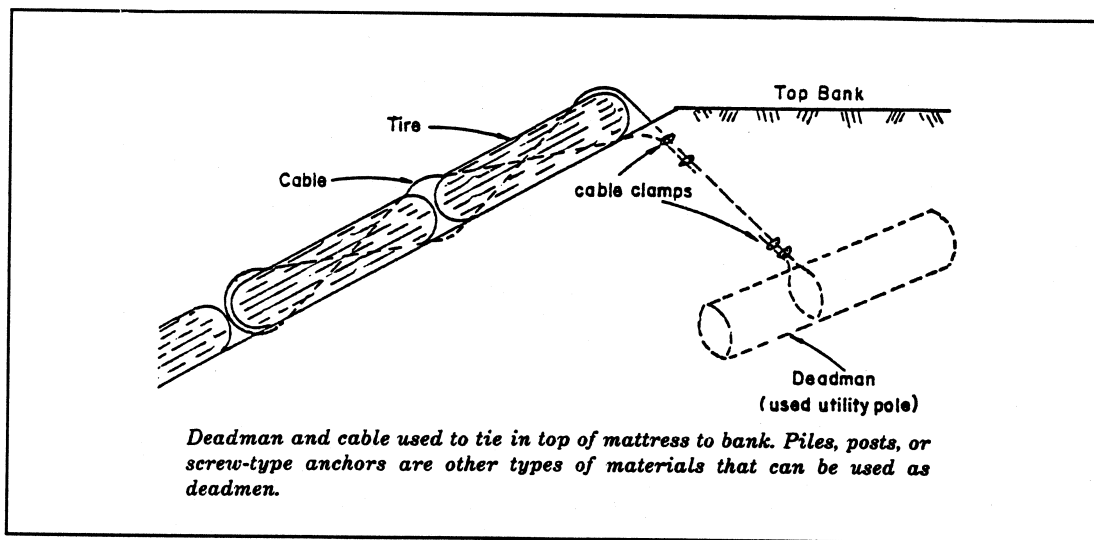


Figure 8.2. Used Tire Riprap (Keown, 1983).

8.3.1.8 Vegetation

Vegetation is most natural and pleasing, and can be easily established. But it alone as a countermeasure to lateral migration of channels at bridge sites should be considered with extreme care. Usually it is used with other types of countermeasures.

HEC-23 discusses vegetation as a countermeasure in qualitative terms. Vegetation works two ways in preventing scour in the bank. The root system creates a binding network within the soil and helps the soil hold together. Below the flow line the branches, leaves, etc. to reduce the flow and help deposition. Above the flow line trees and grasses reduce overland flow and withdraw water from soil, thus reducing the possibility of slope failure.

Vegetation is quite helpful in upper slopes. In lower slopes it is not that effective. Also vegetation can do very little against scour at the toe of the embankment.

Various types of vegetation have been detected for effective scour protection. Grasses are more effective than trees. Trees have deeper root zones, but their weight acts against the stability of the embankment. Rate of growth is a significant factor in choosing a type. Some of the grasses are suitable for scour protection from overland flow, rainfall, and minor wave action. Among these are canary grass, reed grass, cord grass, and fescue. These are suitable for upper banks. In higher erosive forces at lower banks, no vegetation is particularly suitable. However, some shrubs are helpful in reducing velocities and inducing deposition in shallow waters. Among them are cattails, bulrushes, reeds, knotweed, smartweed, rushes, manna grass, and willows. Willows are most effective, as they are resilient, dense and fast growing, and can withstand inundation.

8.3.1.9 Rock-Fill Trenches

Rock-fill trenches are trenches cut along the toe of the embankment filled with rock (Figure 8.3). They are designed so that when the toe of the bank is eroded the extra stone in the trench is moved to the scour hole and paves the bank and stops further undercutting. HEC-23 gives no details for the design of this type of countermeasure.

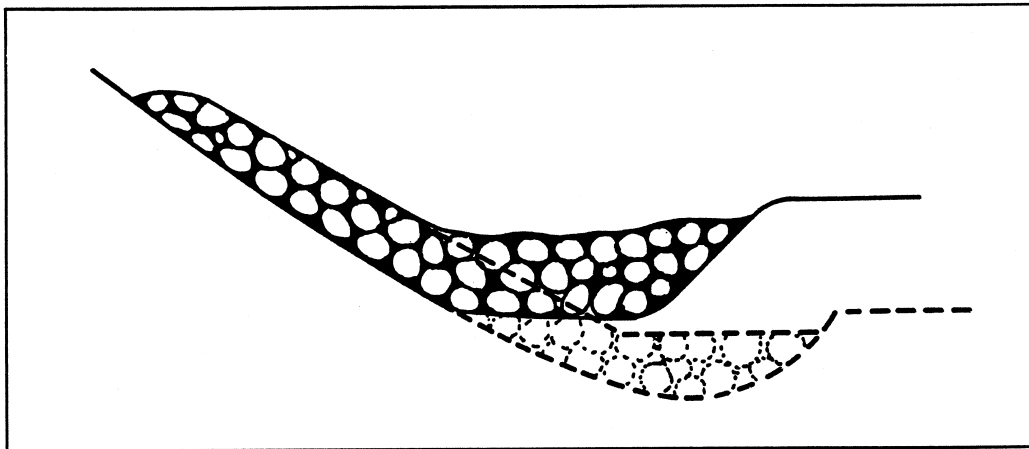


Figure 8.3. Rock-Fill Trench (Richardson, 1990).

8.3.1.10 Windrow Revetment

Windrow revetment is a trench cut on and along the bank and filled with rocks (Figure 8.4). When bank erosion reaches and undercuts the rock fill, it falls onto the eroding area, giving resistance to further undercutting. This countermeasure allows lateral migration to a certain

extent, but aims to arrest migration beyond a certain limit. HEC-23 gives no procedure or guidelines for the design of this countermeasure.

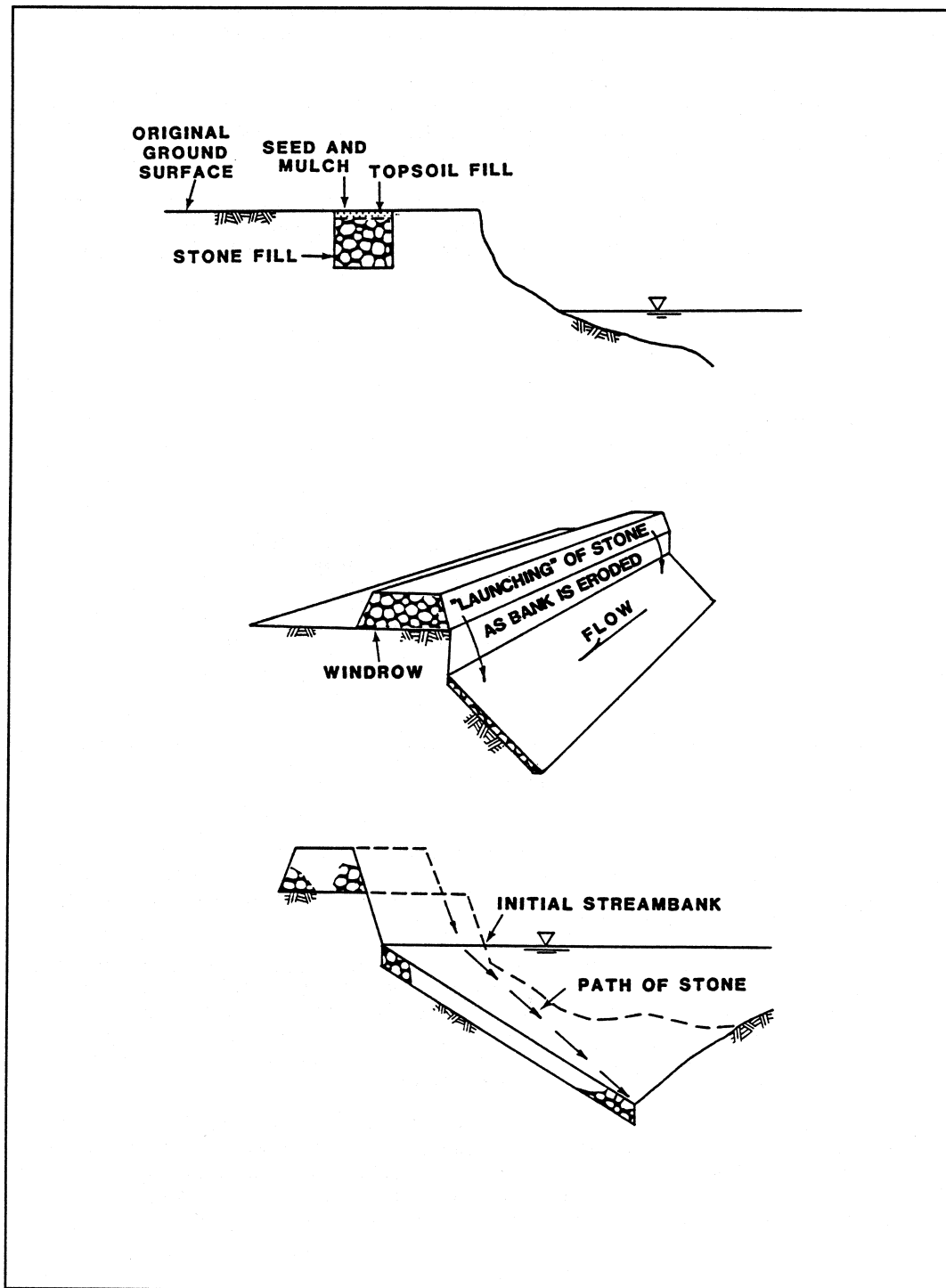


Figure 8.4. Windrow Revetment (USACOE, 1981).

8.3.2 Rigid Revetments

8.3.2.1 Articulated Grout-Filled Mattress

Articulated grout-filled mattresses are series of high strength synthetic fabric bags filled with cement-rich concrete grout and sewn together to form a continuous flexible mat (Figure 8.5).

The seams are often horizontal to allow the mat to hinge along the seam line. The individual blocks are often connected by high strength polyester cables to provide better connection between the blocks.

This type of scour protection can be used both for lateral migration problems at bank and abutment and vertical degradation problems of channel beds.

The design procedure employs a “continuum method” and a factor of safety approach. The mat is considered as a body, and stability of this body is determined based on the total hydraulic shear stress caused by the flow on the entire mat and the resistive stresses acting on the entire mat and anchoring system. A predetermined minimum factor of safety is achieved by design. The factor of safety is chosen on the basis of the importance and risk of failure of the project, the uncertainties in design, the construction, and material properties.

The potential failure mechanism may include piping, washout of sub-soil, excess hydrostatic pressure, and edge undermining. Proper filter design includes weep holes and sufficient trenching into the ground below the scour level.

The necessary design guidelines and specifications are provided in the HEC-23. This includes guidelines for edge trenching, edge tension anchors, key, weepholes, mix strength, slope, grout material, sequence of work, structural impact of permanent anchoring to the pier, filter, and geotextile. Some common problems and their solutions are also discussed.

Specifications for fabric bags are not available. Instead, the specifications of grout bags are recommended.

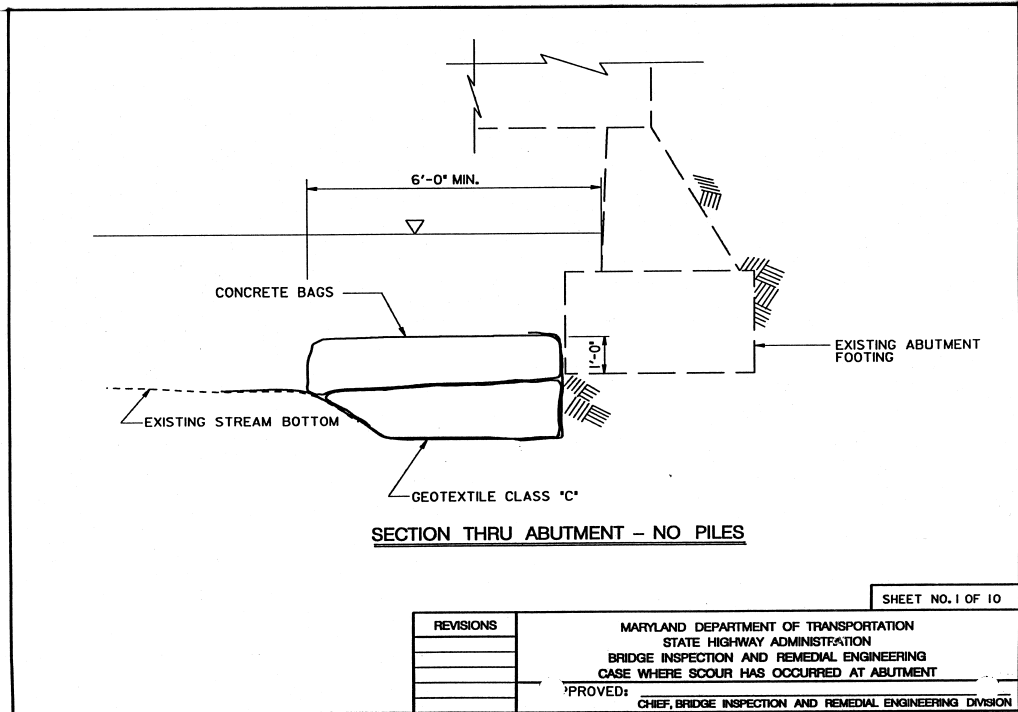


Figure 8.5. Articulated Concrete Bags (Lagasse, 1997).

8.3.2.2 Soil Cement

Where stones for riprap are scarce, soil cement provides a practical alternative countermeasure for scour protection. It can be used for both lateral migration problems and for vertical degradation problems. The common way of using soil cement for lateral instability problems is a rigid revetment along the bank slope in a stair type fashion or in plating parallel to the bank slope. For degradation problems, soil cement is used to construct drop structures in the flow channel. Refer to Figures 8.6 and 8.7.

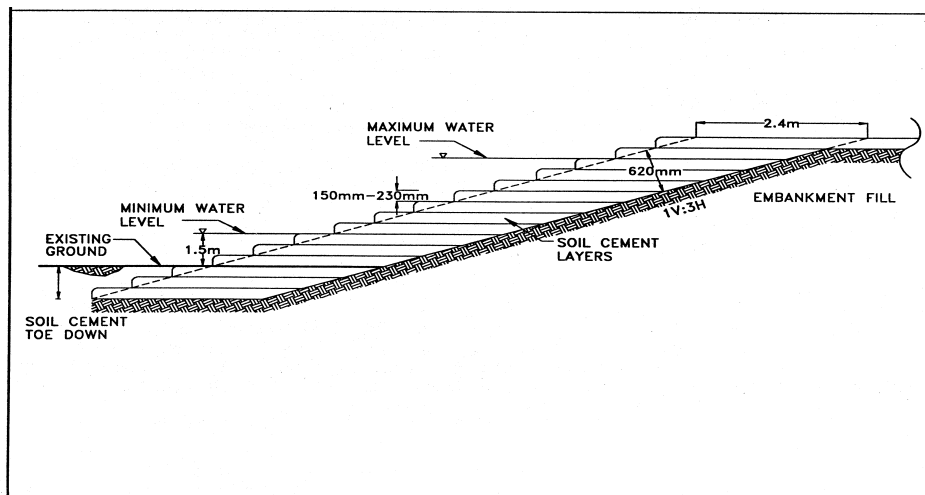


Figure 8.6 Soil Cement Cross-Section (Lagasse, 1997).

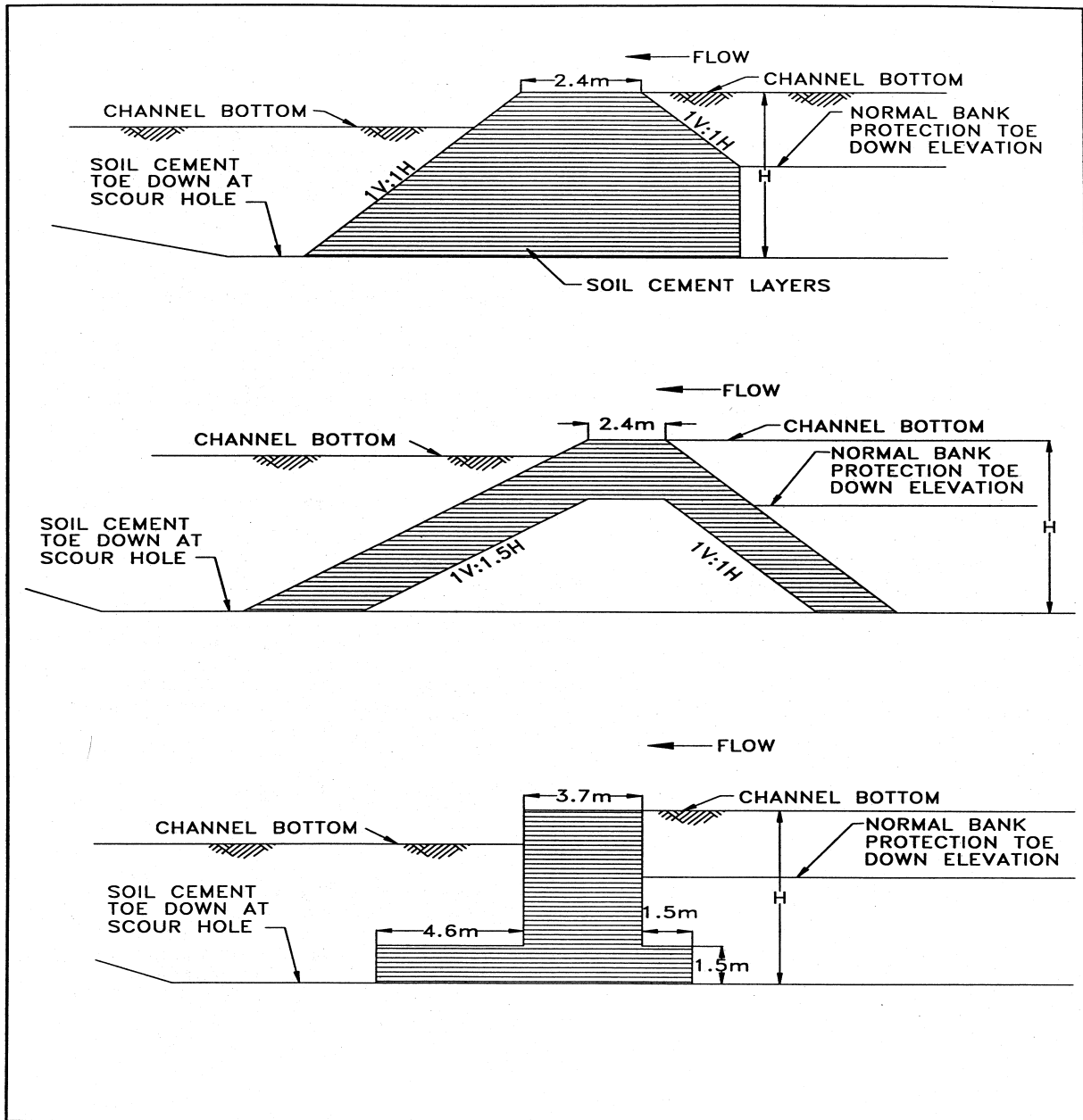


Figure 8.7. Soil Cement (Lagasse, 1997).

The main parameters of design are the width, slope, and thickness of the soil cement layers. The design procedure incorporates neither the flow characteristics nor the soil characteristics. The dimensions recommended are based on experience and/or empirical methods. Specifications for material, mix design, batch plant mixing, and construction are available for this countermeasure option. One very important issue is edge protection to prevent undermining.

The use of soil cement is relatively low. Therefore adequate case study data are not available. HEC-23 reports that its use in the southwestern United States is successful.

8.3.2.3 Concrete Pavement

A rigid concrete pavement is constructed on the face of the stream bank or embankment to protect from scour and thus prevent lateral migration of channels. Sometimes in the smaller channels the whole channel is lined with concrete pavement, thus preventing both vertical degradation and lateral migration.

The design must include provision for proper edge treatment to avoid undermining and dissipation of excess hydrostatic pressure by means of weep holes. Any portion permanently under water may be impermeable.

8.3.2.4 Sacked Concrete/Sacks

Sacks filled with concrete or soil and sand-cement mixture can be used when suitable stone is not available economically. Their performance is not as good as stone riprap. This is usually used for temporary emergency works. If more permanent use is anticipated proper mix design is necessary for proper setup. Sacks are easily damaged and eventually deteriorate.

Sacks are generally cheaper than stone riprap in terms of the cost of material and construction. Construction is relatively easy too. In HEC-23 very little information regarding design or material specification is provided.

The sacks are placed in horizontal rows or in plating parallel to the bank slope. For degradation problems soil cement is used to construct drop structures in the flow channel. Brickwork along the slope of the finished face of the bank or abutment can also be used to a depth below the scour level. The slope is maintained not steeper than 1:1. For a permanent construction, 15 percent cement with 85 percent dry sand by weight is used. Weep holes should be provided as leached out cement tends to form bonds between the sacks and prevents drainage of ground water. This type of countermeasure needs edge treatment like any other type of revetment.

8.4 FLOW CONTROL STRUCTURES

8.4.1 Check Dams / Drop Structures

Check dams or channel drop structures are used to maintain a stable bed elevation (Figure 8.8). This reduces the upstream slope and changes the flow characteristics to a milder and more favorable condition. They are installed downstream of the bridge site. They can be constructed of rock, timber, steel sheet pile, gabions, and concrete treated timber.

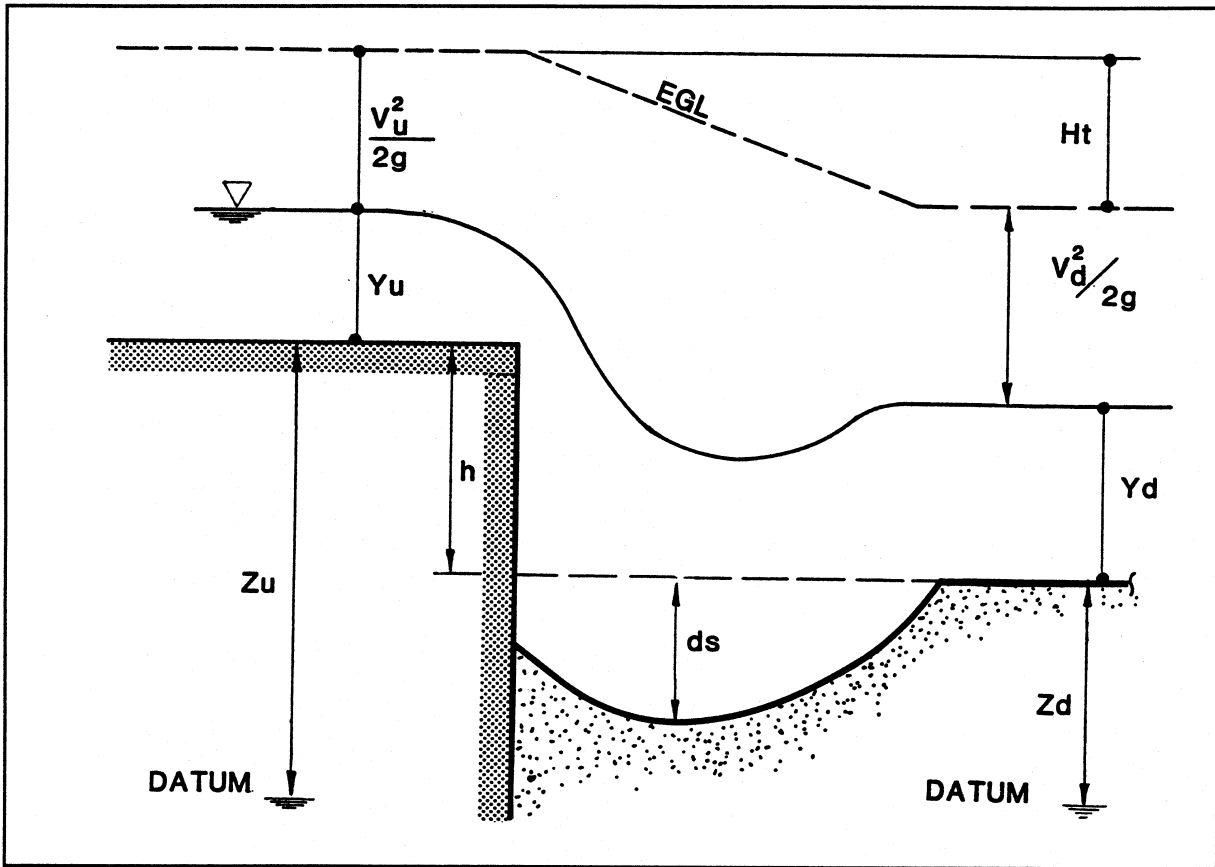


Figure 8.8. Check Dam (Lagasse, 1995).

The main design feature is the stable elevation of the streambed that would help avoid any scour at the bridge site. Parameters that are used in the design are flow discharge, velocity, upstream and downstream flow depths, and channel dimensions.

An important feature of the drop structures is that they themselves can initiate scour downstream and at the flanks. This scour may proceed upstream and endanger the bridge. The design procedure has to address these problems adequately. Drop structures are often designed with stream bed and side bank armoring or installed in several smaller drops to reduce scour downstream. Stilling basins are also used to protect against scour downstream. (Figure 8.9)

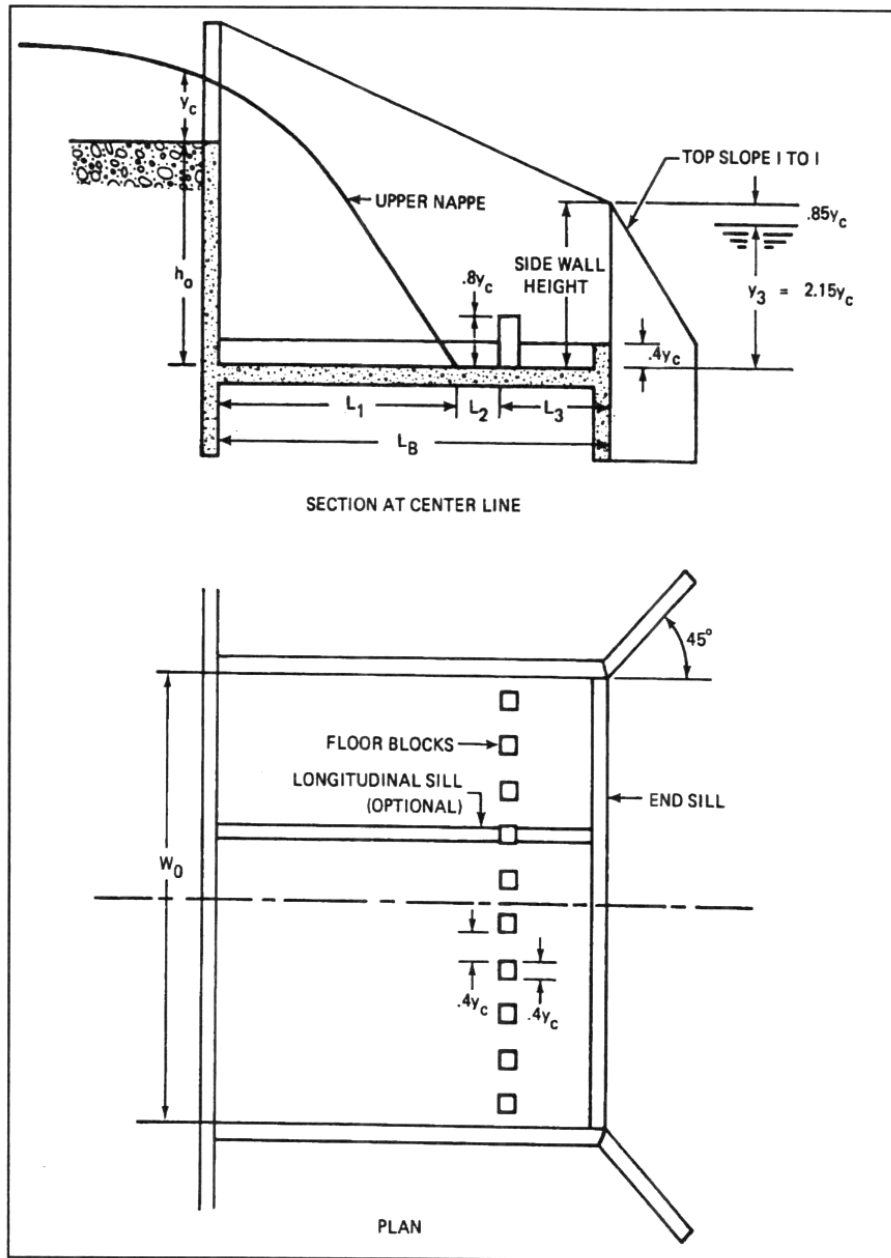


Figure 8.9. Stilling Basin (Peterka, 1964).

HEC-23 provides design guidelines for both check dams and stilling basins. Formulae and design charts are provided. These formulae are based on hydraulic consideration. Soil properties are not incorporated.

8.4.2 Spurs

Spurs are used at a bend to control meander migration. They can be used upstream of a bridge site where a meander migration is threatening to encroach the bridge abutments or approach. Spurs are structures projecting into the stream from the bank. They are designed to reduce flow

velocities near the bank, cause sediment deposition near the bank, divert the flow toward the channel midstream, and help maintain a stable flow channel. (Figure 8.10.) Thus they prevent scouring of the bank and retard meander migration. Various types of spurs can be designed for various types of situations using various types of materials.

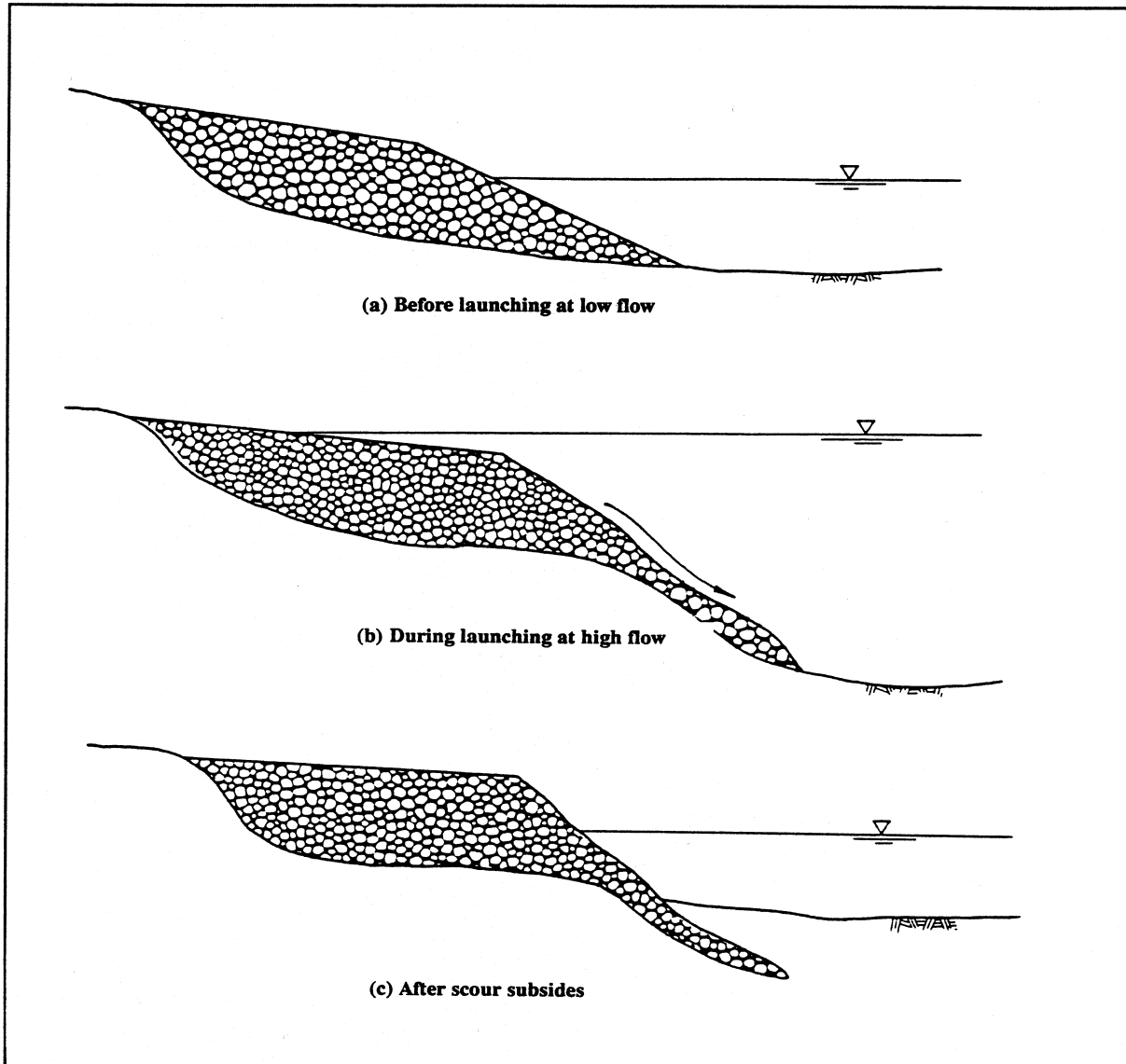


Figure 8.10. Spur (Brown, 1985).

The main design features are the longitudinal extent of a spur field, spur length, orientation, permeability, spacing, size, shape and slope, bed, and bank contact (Figure 8.11). Design parameters that are considered include bend length, width, extent of present scour, channel width, permeability of spurs, flow velocity, debris, and sediment load, etc.

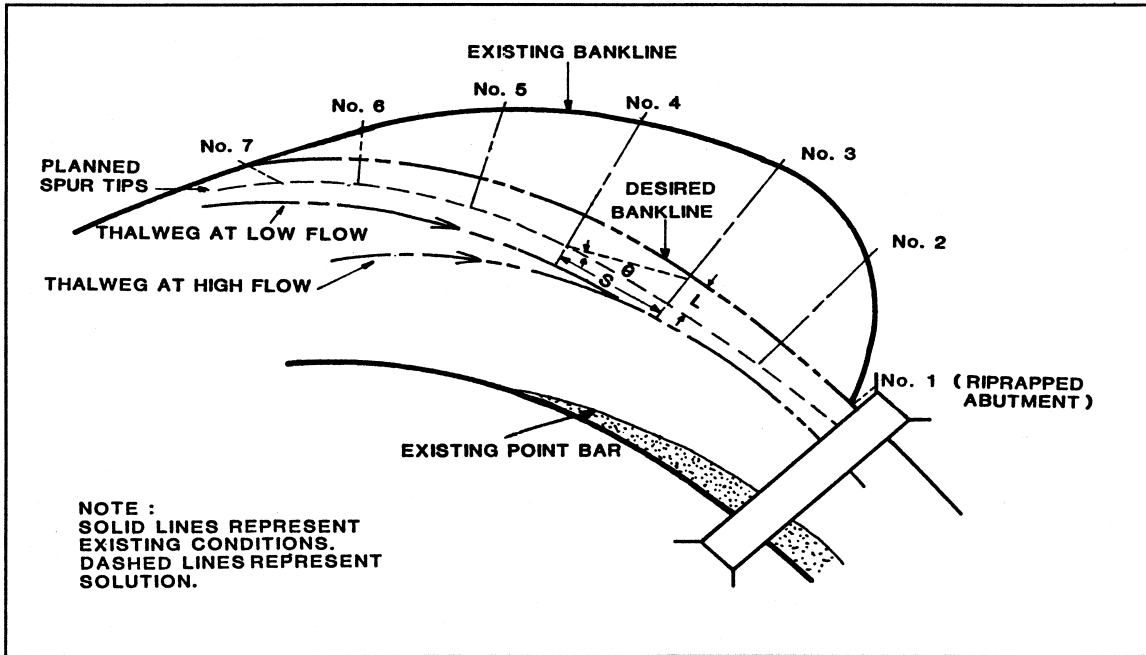


Figure 8.11. Spur Field (Lagasse, 1995).

A general discussion regarding design procedures is presented in HEC-23 but no rigorous method for selecting the parameters is presented. Few formulae and design charts are provided. No mention of geotechnical properties of the bank or bed soil is made. No assessment of possible future extent of scour is incorporated in the design process.

A few occurrences of failure are mentioned in HEC-23. In some of the failure cases it was found that the designed length, and the spacing and/or embedment into the soil was not sufficient. The design procedure does not include properties of the soil being eroded, while in the authors' opinion it may have a significant impact on the success of this countermeasure. The design procedure is not specific in this case.

8.4.3 Permeable Spurs

Permeable spurs are most effective when placed at right angles to the bank or inclined downstream. A slight upstream inclination has some advantages for impermeable spurs, particularly when they are used to confine shallow channels. In view of the high cost of riprap and of conventional spurs and the dominance of lateral stream migration problems at bridges, new spur types are needed. Engineers should incorporate permeability, flexibility, low cost, and expendability into the design.

8.4.4 Retards

Retards are used for control of flow alignment at sharp bends near bridges and for other situations in which flow impinges directly on a bank near a bridge. Retards can be of various types made of various materials, but they all work in the same way. They are generally placed parallel to the bank line. They collect debris, decrease the flow velocity, induce deposition, and

redirect flow towards the mid-stream flow line. HEC-23 provides general information about the design of this type of countermeasure. Some common types are discussed below.

8.4.4.1 Jacks and Tetrahedrons

Jacks are generally made of three mutually perpendicular rails connected at their mid points. Wire or wire mesh is strung to the rails to help collect debris. They are placed along the bank line to a certain distance arranged in a area where they are cable tied to one another. This field is often called a jack field. (Figure 8.12.)

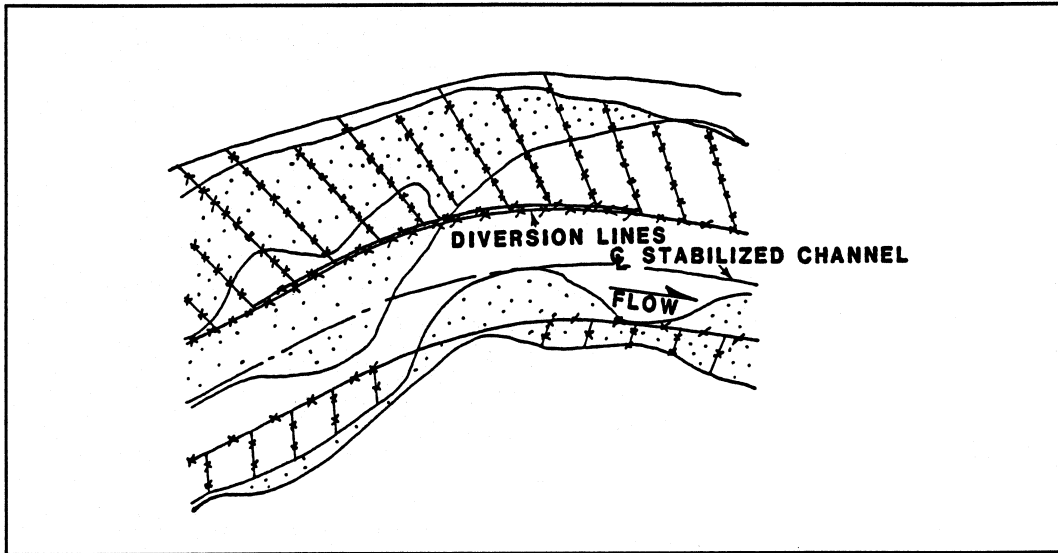


Figure 8.12. Jack Field (Richardson, 1990).

Tetrahedrons are six linear members such as rails that are connected to form a tetrahedron (Figure 8.13). Wire or wire mesh is strung to increase debris collection and flow retardance. They are also placed like the jacks.

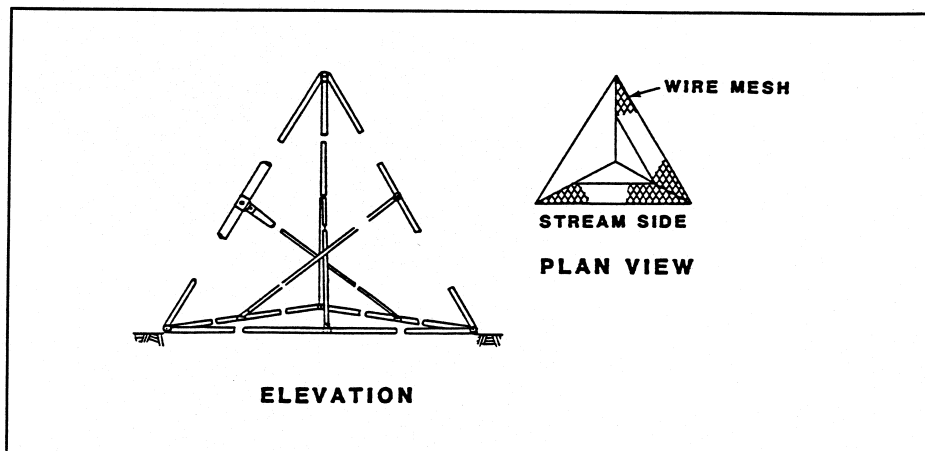


Figure 8.13. Tetrahedrons (Brown, 1985).

They work well on a mild bend and in shallow waters where flow carries light debris. They may not work in a stream which carries heavy debris and/or ice, which may cause severe damage to this type of countermeasure.

8.4.4.2 Fence Retards

Fence can be used as a retard structure to prevent bank erosion in the lower portion of small streams. Fence can be made of posts of wood, steel, and concrete with fencing of wood planks or wire mesh.

These types of countermeasures fail due to flow development and erosion behind the fence. To prevent that, rocks may be placed along the retard. Also driving supporting members to a depth below scour level will do. Tie backs may also be used.

8.4.4.3 Timber Piles

Timber piles in one, two, or three rows can be used as a retard. The piles are braced together and the outer face is fenced with wire mesh or wood planks (Figure 8.14).

This countermeasure is more effective than most retards. They can be used in sharp bends and in a stream that carries heavy debris and ice and in streams where shipping vessels may cause damage to other types of countermeasures. Proper protection against scour failure of this structure is needed for reliable performance.

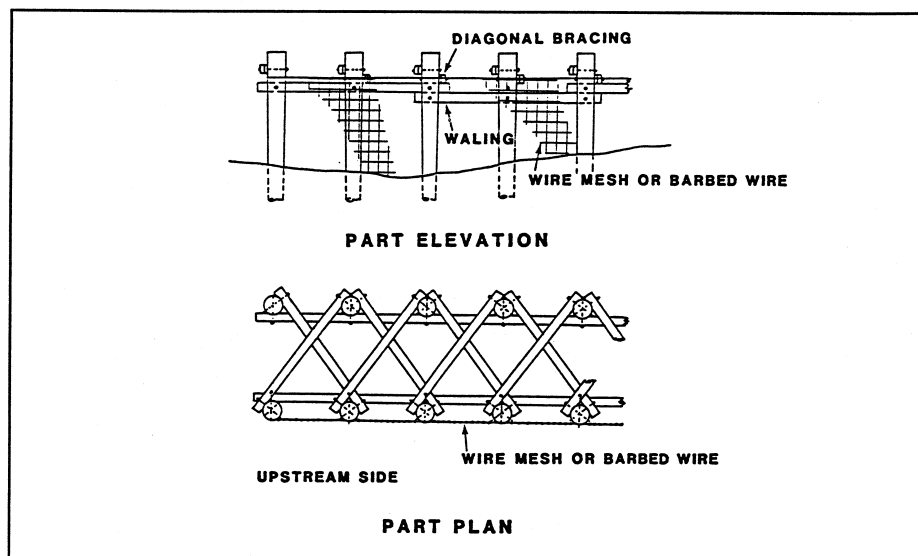


Figure 8.14. Timber Pile Retards (Brown, 1985).

8.4.4.4 Wood Fences

This type of countermeasure consists of timber piles tied back to anchor piles and placement of stone at the foundation. The facing can be of wood planks or wire mesh. This type of countermeasure also works well where the flow directly hits the bank. Wood fences can be used

in a linear or area configuration of single and multiple rows. This is most suitable for preventing bank erosion of realigned channels

8.4.5 Dikes

Dikes are impermeable linear structures that are used for control and containment of the flow. They may be on the bank or in the channel, and they may be of considerable length. Dikes may be of several types which are discussed below.

8.4.5.1 Longitudinal Dikes

Longitudinal dikes are impermeable linear structures placed in the stream near and along the bank line to prevent the flow from hitting the bank. In a bend they move the current away from the bank. They are classified as earth or rock dikes, crib dikes, or rock-toe dikes.

8.4.5.2 Earth or Rock Dikes

They consist of earth or rock. They are usually as high or higher than the original bank, and therefore are costly, so their use is limited. They are used in projects like large-scale channel realignment projects.

8.4.5.3 Crib Dikes

Longitudinal crib structures made of timber and filled with rock, brush, tire, or other material can be used to prevent scour at low banks or lower portions of high banks (Figure 8.15). They are not very useful in sharp bends and may need additional protection like tiebacks.

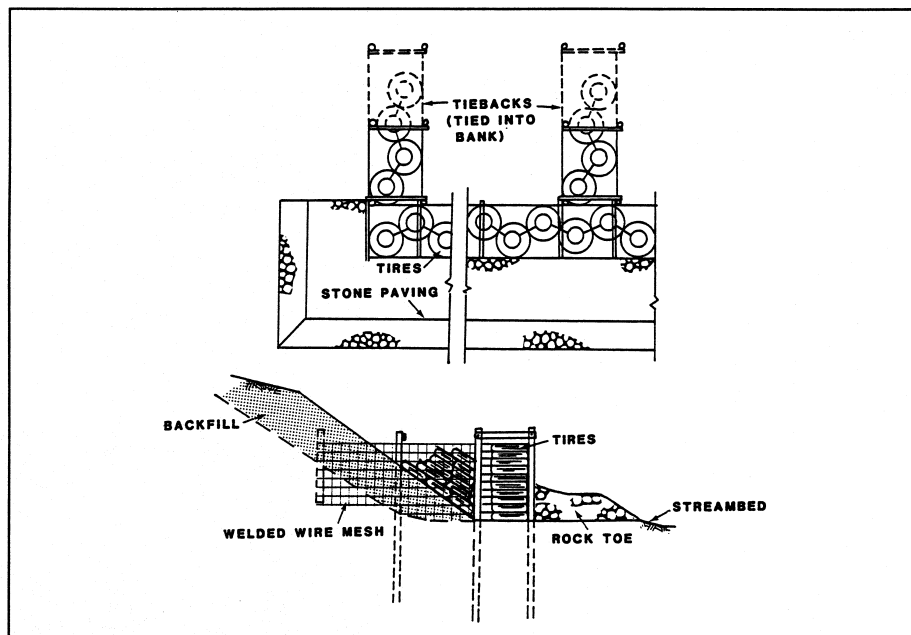


Figure 8.15. Timber Crib Dike (Brown, 1985).

8.4.5.4 Rock-Toe Dikes

Rock-toe dikes are rock riprap placed along the toe of a bank (Figure 8.16). They aim mainly to protect the toe region of a bank. It is one of the most successful countermeasures. It is usually used with other types of countermeasures.

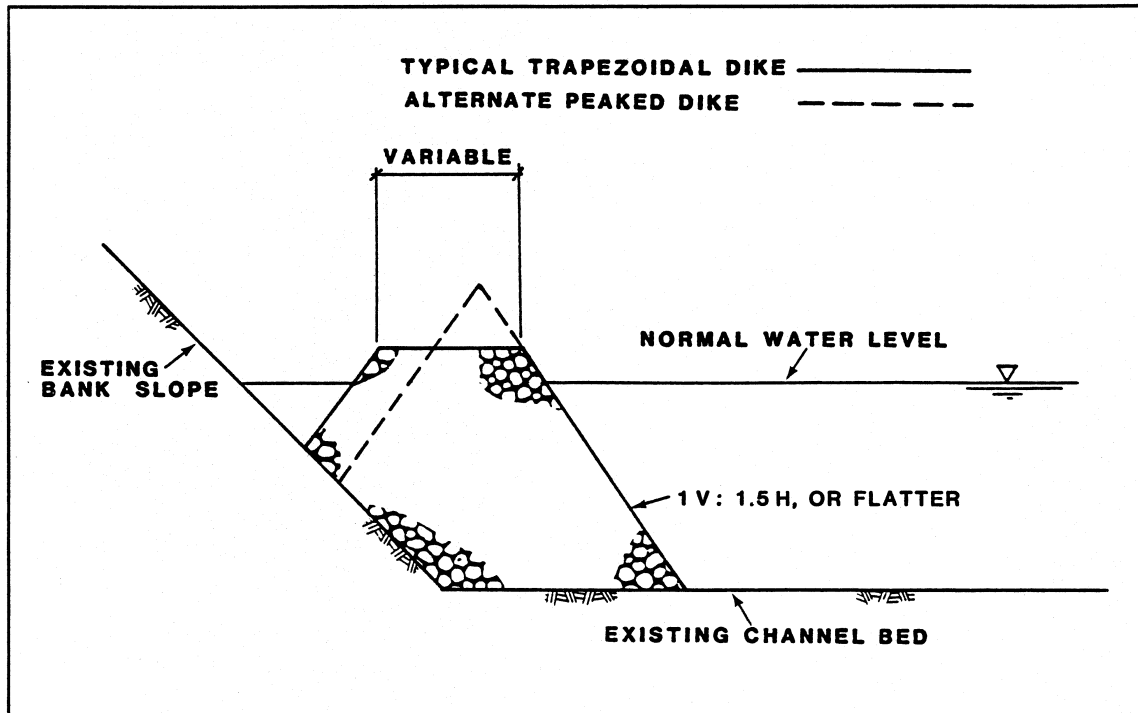


Figure 8.16. Rock Toe-Dike (Brown, 1985).

Usually it requires more material and is costly. Where a large conveyance for navigational purposes is not required, spurs can be used economically instead of rock-toe dikes.

8.4.6 Guide Banks or Spur Dikes

When a bridge approach embankment encroaches on flood plains and constricts the flow, guide banks or spur dikes are used to converge the flow and make it flow parallel to the embankment and under the bridge (Figure 8.17).

The main factors that are considered in the design of a guide bank are its orientation, opening, shape, height, and length. The length of the guide bank is determined based on the flow characteristics and bridge dimensions, namely channel and flood plain discharge, cross sectional area of flow, and length of bridge opening. A detailed and well-defined procedure is described in HEC-23. Again, no mention is made of geotechnical properties for bed, bank, and floodplain material, guide bank material, or sediments, etc.

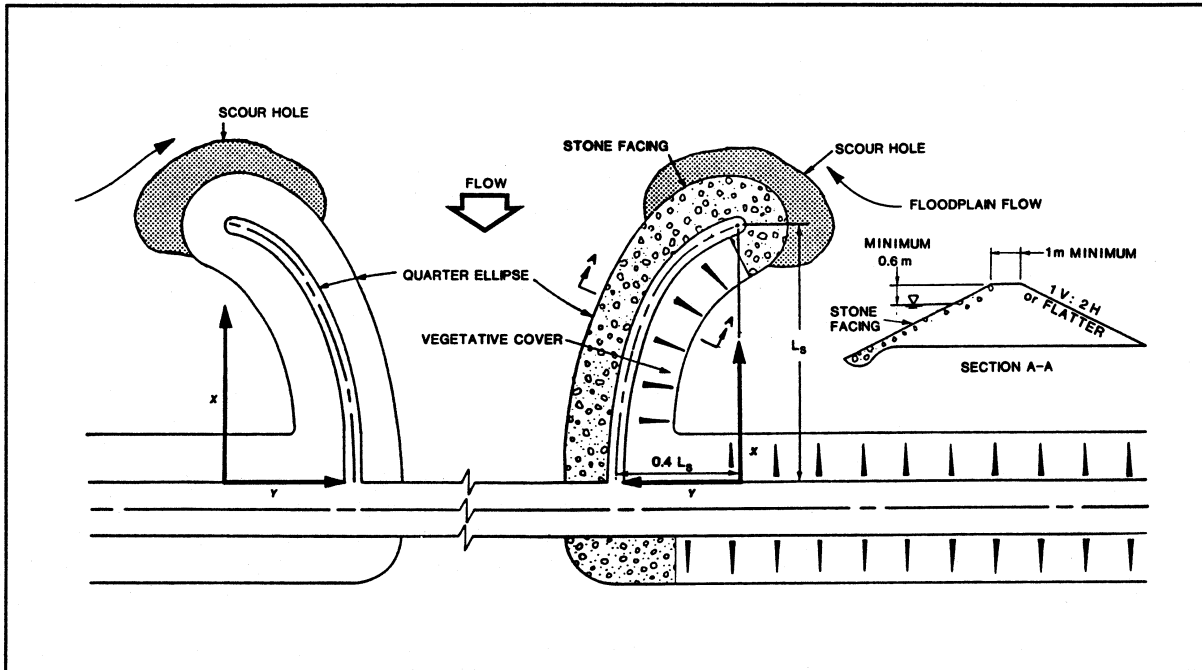


Figure 8.17. Guide Banks or Spur Dikes (modified from Bradley, 1978).

A well-designed guide bank with properly designed revetment works very well. Partial failure of any part of the revetment does not threaten the guide bank significantly if it is repaired regularly. Therefore the success rate for guide banks is high. Yet there are cases where limited success is encountered. This occurs if, for example, flow is not aligned as assumed in the design.

8.4.7. Bendway Weirs

Bendway weirs are structures similar to stone spurs, but they work differently. They project from the bank into the stream and are submerged during the design flow. They alter the flow hydraulics and cause the flow to change direction midstream as it passes over the weirs. They reduce flow velocity, redirect flow, and induce deposition thus retarding bend migration. They are made of various types of materials.

The design procedure is a rule of thumb method with some empirical formulas, and general guidelines for limiting values. The main design features are the length, angle to flow, size, shape, key, embedment and stone size. The parameters used for design are depth of flow, bend and stream dimensions such as radius of curvature, and channel width, etc. Yet again no reference is made to geotechnical properties of bed and bank soil. HEC-23 observes that bendway weirs do not work well in degrading or sediment deficient reaches. The following [Figure 8.18](#) and [Figure 8.19](#) is showing typical plan view and cross-section of bendway weir.

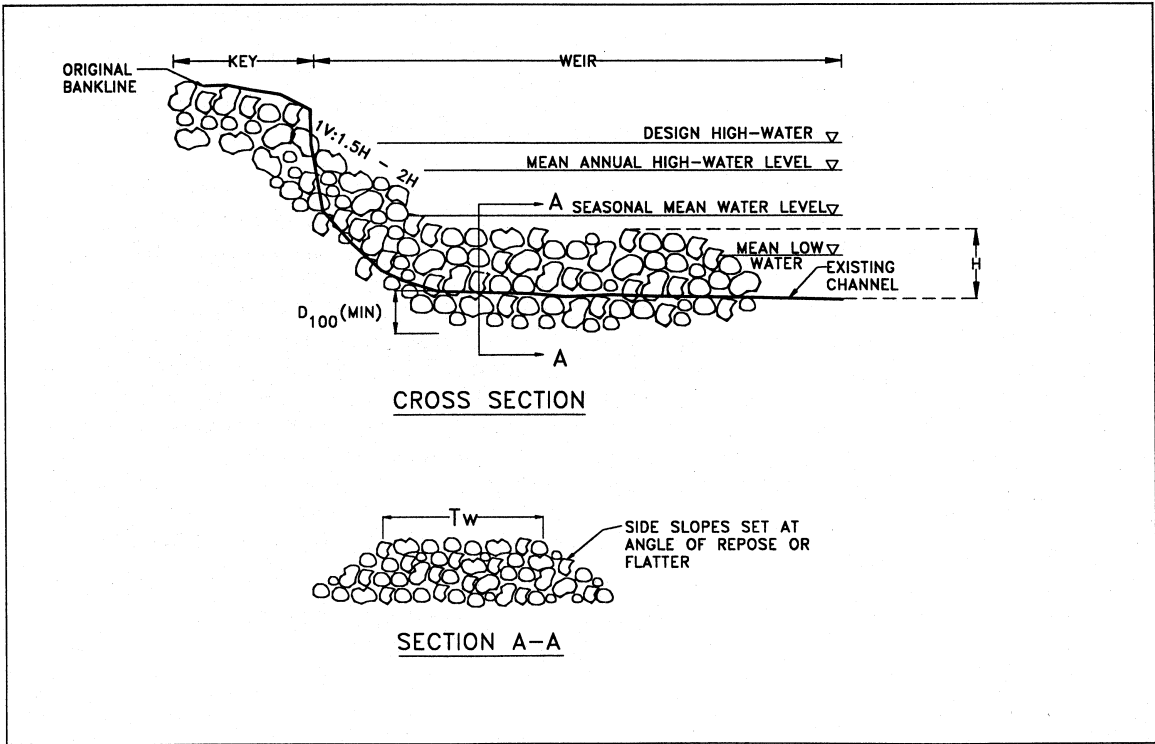


Figure 8.18. Bendway Weir Typical Cross-Section (Lagasse, 1997).

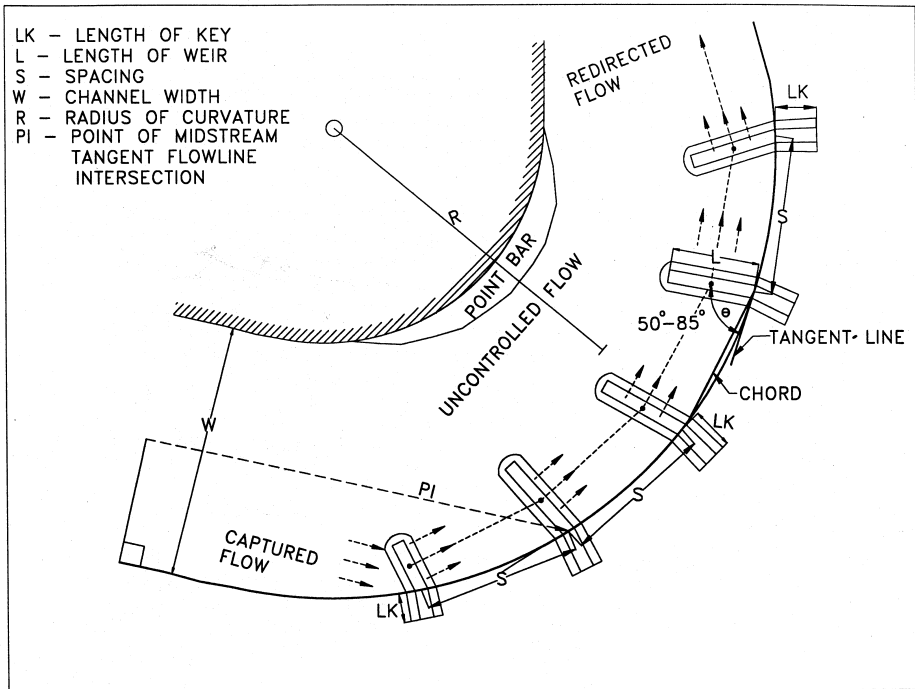


Figure 8.19. Bendway Weir Typical Plan View (Lagasse, 1997).

8.4.8 Hard Points

Hard points are stone fills spaced along the eroding bank line, extending from the bank into the stream by only a short distance. A root section extends landward to protect against flanking (Figure 8.20).

Hard points are used to prevent lateral migration of streams. Hard points work in the same way spurs work, but are suitable for only relatively straight streams. Small velocities near the bank line where the scour occurs mainly due to a wandering thalweg at lower flow rates. It is not suitable for preventing bank erosion in a bend.

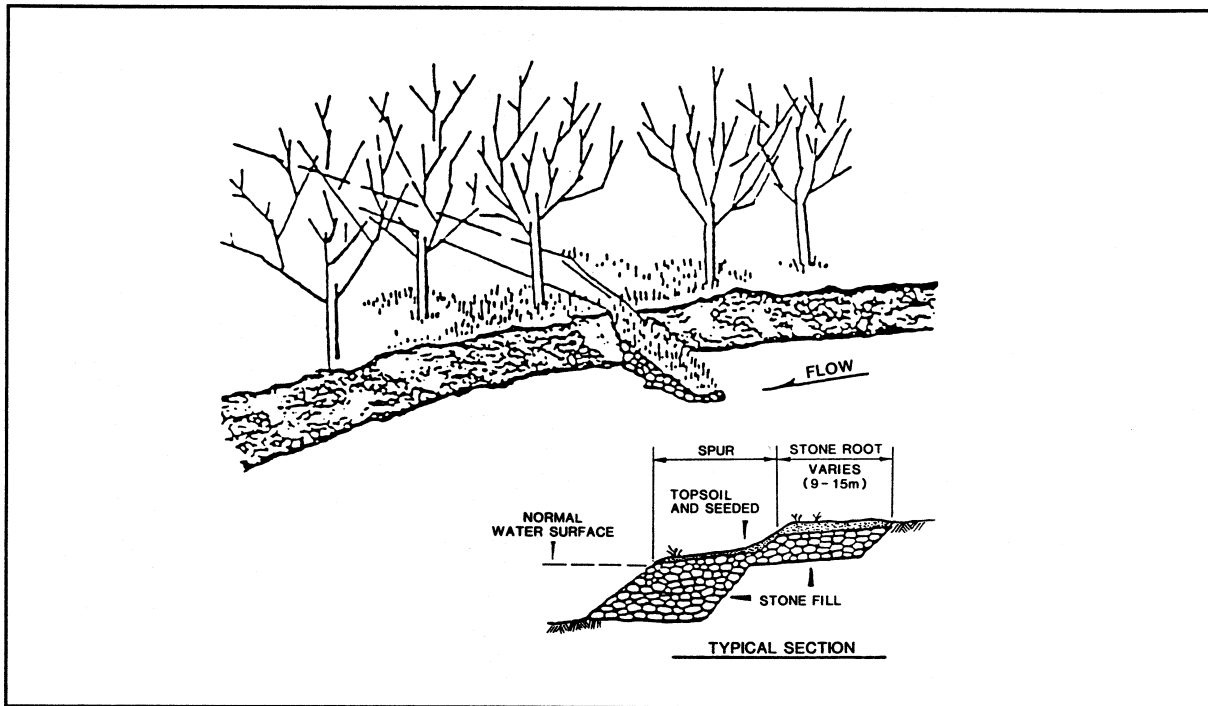


Figure 8.20. Hard Point (Brown, 1985).

8.5 BULKHEADS

Bulkheads are advantageous for control of the slope failure when the slope cannot be graded to a low angle for the placement of other revetments. They are used to protect lower portions of the bank. They are often used with other countermeasures, where other types of countermeasures cannot be used. (Figure 8.21.)

They may be made of various materials such as concrete, masonry, cribs, sheet metal, piling, reinforced earth, gabions, used tires, or other materials. They prevent scour at lower elevations and prevent undermining and slumping of soil retained. They must include provisions for seepage through the wall.

8.7 PUBLISHED CASE HISTORIES IN TEXAS

Some case histories in Texas are presented in the following report.

8.7.1 East Fork Trinity River at Atchison, Topeka, and Santa Fe Railway Bridge near Lavon, Texas

At this site, relocation of the channel apparently contributed to instability. Stream bed degradation continued for about 15 years before the channel approached stability. The cutoff wall built at the toe of the existing concrete slope paving was insufficient to prevent undermining.

8.7.2 Trinity River at FM 162 near Moss Hill, Texas

Because the bridge crossed the Trinity River at a meander bend, problems of channel stability and scour were anticipated in the bridge design. Specific measures to protect the bridge included: (1) placement of the main channel pier footings seal level at least 15 ft (5 m) below the streambed, (2) prevention of channel meander movement by use of five timber spurs placed upstream from the bridge, and (3) in anticipation of future meander bend movement, the seal level for pier 13 was placed about 40 ft (12 m) below the level of the flood plain to anticipate scour problems. Protection of the channel bank by the timber spurs was limited to a distance downstream from the lower spur about equal to the distance the spur extended into the main channel. Lateral movement of the meander bend at the bridge was about 70 ft (21 m) during a period of 10 years even though timber spurs were constructed upstream from the bridge to prevent channel movement.

Unanticipated scour about 9 ft (3 m) deep occurred at the point bar on the right side of the channel, exposing the footings of several piers. This occurrence indicates the entire channel geometry is changing, and plans to protect the bridge from scour and erosion should consider the entire channel. Bank and channel bed countermeasures built in 1977 utilized rock-riprap revetment to prevent further channel changes at the bridge rather than flow control structures such as additional spurs. The effectiveness of the new measures has not been determined.

8.7.3 Brazos River at FM 1462 near Rosharon, Texas

Use of steel sheet-piling and concrete rubble as bank and abutment revetment did not prevent continued lateral erosion at a meander bend on the Brazos River. Bank protection is difficult because of the height of the banks (about 30 ft or 9 m) and the tendency of the banks to slump.

8.7.4 Cold Creek at SR 71 near Pontotoc, Texas

The bridge piling was embedded in sandstone that provided resistance to local scour and to the effects of impact or lateral forces associated with submergence of the bridge structure. Several features of the bridge facilitated the passage of flood flows when the bridge was overtopped. The

guardrail and support posts provided minimal depth, about 1 ft (0.3 m) thickness, that reduced the amount of lateral force on the bridge and the potential for lodgment of debris.

8.7.5 Colorado River at U.S. 90 at Columbus, Texas

The bridge was constructed at a meander, and for a period of about 10 years, lateral migration of the meander caused erosion of the channel bank and potential exposure of the right bank pier and abutment. This case history demonstrates the hydraulic problems that occur when piers constructed near a channel bank cause a concentration of flow between the pier and bank and higher than normal velocities. These higher velocities can cause significant lateral erosion (in this case over 50 ft or 15 m) of the bank over a period of several years. The steel jack jetty field reduced the velocity of flow from 9 ft/s (3 m/s) to 5 ft/s (1.5 m/s) near the stream bank during large floods. Following construction of the jack jetty field, the eroded bank was built out about 20 ft (6 m) by the deposition of material. The reduction in flow velocities to about 4 or 5 ft/s (1 to 1.5 m/s) was apparently sufficient to induce deposition of sediment and growth of vegetation.

8.7.6 Gills Branch at SR 21 at Bastrop, Texas

The concrete-lined channel apparently was not designed for the possibility of excessive hydrostatic pressure causing uplift of the lining. The relocated channel, with fewer bends and a shorter length, had a steeper gradient and higher flow velocities than the original channel. A scour hole or plunge pool developed at the point of intersection of the old and new channels and served as an energy dissipator for the increased flow velocities that develop in the new channel. In general, the design of relocated channels should consider the probability of scour and lateral erosion at the exit of a relocated channel. The location, (relative to the bridge), and ultimate size of the scour hole should be evaluated. Channel stabilization measures at the potential scour hole, such as revetment, may be needed.

8.7.7 Atascosa River at FM 99 near Whitsett, Texas

The approach embankment on the flood plain caused a significant amount of flow contraction and resultant general scour at the bridge during a large flood. Both toe and end protections are needed to prevent future damage to the concrete slope pavement by scour and undermining.

8.7.8 Tunis Creek at I-10 near Bakersfield, Texas

The spur dike built to prevent lateral flow along the approach embankment and to align flows with the bridge opening performed as intended during the flood, which reached the top of the dike. However, the spur dike was damaged and a scour hole developed at the upstream end as flows passed around the dike and high flow velocities developed. A concrete toe wall placed 3 ft (1 m) below the ground line to prevent undermining of the concrete pavement on the spur dike was unsuccessful during the 1974 flood.

8.7.9 Brazos River at FM 529 near Bellville, Texas

A steel sheet-pile bulkhead was built to prevent undermining, by lateral bank erosion, of a pile-supported pier located near the streambank. Performance of this countermeasure was not evaluated.

8.7.10 Overflow Channel, Nueces, and Frio Rivers at U.S. 281 near Three Rivers, Texas

Bridges across the overflow channel caused significant lateral contraction of flood flow. Because the bridge waterway was inadequate, general scour and lateral erosion at the contraction resulted. The contraction of flow at the dual bridges during flooding by hurricane Beulah was caused by several factors. The dual bridge itself caused an impediment to flow and reduced the hydraulic efficiency of the waterway between abutments. For example, bridge piling and bents occupied space in the waterway. In addition, the pile bents caused turbulence of flow which affected the flow patterns. The amount of flow turbulence was also affected by the closeness (span length) of adjacent bents (close spacing of bents caused greater amounts of flow turbulence). The approach embankments forced water on the floodplain to move laterally along the embankment and then change directions at the bridge before passing through the opening. Normal flow patterns in the main overflow channel were affected by flows moving laterally along the embankment.

8.7.11 Merrill Creek at FM 1550 near Ladonia, Texas

Channel alignment and clearing work on the North Sulphur River apparently caused changes in the Merrill Creek gradient and subsequent channel degradation and lateral erosion. The time interval between the channel change and a return to channel stability may require more than 50 years. The amount of channel change and duration of instability depend on flow conditions and geologic features of the basin. In the construction of new bridges across an actively degrading or unstable stream channel such as Merrill Creek, the possible occurrence of both channel bed lowering and lateral erosion should be considered. Although no countermeasures were applied except for lengthening of the bridge, this case is documented here because it is a typical example of hydraulic problems caused by stream channelization.

8.7.12 Sabine Pass at Louisiana SR 82 near port Arthur, Texas

Erosion at the left abutment on the Louisiana side is attributed to an exposed position at the tip of a peninsula. Concrete blocks have performed satisfactorily in the immediate area of the abutment, but additional protection is needed along the approach embankment adjacent to the abutment.

8.7.13 Mountain Creek at Dallas-Ft. Worth Turnpike, Texas

Inasmuch as the pier columns are round, the bridge designers probably believed that skewings of the bents to flow direction would be of little consequence, but this proved not to be the case. The banks of the natural channel upstream from the bridge are much scarred by slumping and this might have served as a warning of bank instability at the bridge. Flow alignment through the bridge could have been (and could be) improved by a small amount of channel alteration. In

view of the fact that the stream is not very sinuous and the banks are already unstable, straightening of a short reach would not likely have any significant consequences with respect to channel stability.

8.7.14 Brazos River at Pipeline Crossing near U.S. 90A, near Houston, Texas

Spur jetties have stabilized a high, eroding bank at a bend of the Brazos River. The difficulty of controlling lateral erosion on the Brazos is judged to be greater than average for meandering rivers because of the height and erodibility of the banks and the frequency of bankfull flows. However, conditions are favorable for the performance of permeable spurs, because the river transports a substantial sediment load, and the climate promotes the establishment of vegetation. Although spur jetties normally require routine maintenance, particularly if they are damaged by floating drift, this particular installation has required no maintenance since the first year.

8.8 EXCERPTS FROM OTHER REFERENCES

Some other reports and papers have been searched to investigate the current practice regarding countermeasure selection and design. The excerpts are presented below.

8.8.1 Abam, T. K. S., Okagbue, C. O., 1986, “Construction and Performance of Riverbank Erosion Protection Structure in the Niger Delta.”

Bank erosion in the Niger Delta has been successfully minimized by the use of sand-fill embankments protected by synthetic polypropylene mattress. The success or failure of such a protective measure depends, however, on the properties of the dredged sand as well as the nature of the river bed. It can also depend on the nature of the thalweg of the river. From the study the following conclusions can be drawn:

1. The percentage of silt/clay content which in turn determines the angle of internal friction is a critical factor in the stability of sand embankment by hydraulic sand-fill from river bed borrow pits in the freshwater zone of the Niger Delta. Field and laboratory work show that the percentage of fines content to achieve stability is about two.
2. A river bed covered by a clay layer can be a potential failure surface in a river bank protected by a dredged sand embankment.
3. Where the thalweg of the river is in sand, the erosive surge of water during high river stage is greatly enhanced. This leads to steepening of the toes of banks from a stable slope to one which is unstable.
4. Design calculations for erosion protection structures should not be regarded as foolproof. Such calculations must be backed by successful field operations. The design of a river bank protection structure is thus a continuous one until the structure is successfully completed.

8.8.2 Abam, T. K. S., 1993, “Control of Channel Bank Erosion using Permeable Groins.”

The effectiveness of the groin system cannot be guaranteed if any local failures occur. Such failures generate distortions in the flow pattern in the immediate vicinity of the piles, causing scouring and endangering the stability of the entire groin system. Despite sinking pilings 1.1

times the calculated minimum depth, larger than expected forces must have been developed against the pilings during the high water period. It is apparent that the groins were constructed for average rather than extreme conditions. Although the stability of the groin system is affected by several factors, the depth of embedment is the most significant factor controlling groin stability. This means that a unit increase in depth and the depth embedment of the pile below a riverbed causes the most improvement in the stability of the groin system. In the case of a groin, two definitions of factor of safety are possible as follow:

1. Factor of safety with respect to the lateral earth pressure of the soil. This factor of safety can be defined as the ratio of the sum of resisting forces to the sum of disturbing forces.
2. Factor of safety with respect to the depth of embedment. This is the ratio of the depth of embedment below the riverbed to the minimum depth of embedment required for equilibrium. The advantage in the use of this definition is that it easily allows anticipated scour to be adequately provided for in the determination of a suitable depth of embedment.

8.8.3 Brice, J. C., Blodgett, J.C., 1978, “Countermeasures for Hydraulic Problems at Bridges.”

Guidelines suggested here for the use of countermeasures are based on case histories of 223 bridges sites in the U.S. and Canada, on interviews with bridge engineers in 34 states, and on a survey of published work on countermeasures. As an essential aspect of countermeasure use and performance, factors contributing to hydraulic problems at bridges are analyzed, with particular regard to stream properties and behavior.

Scour is regarded as vertical erosion of a surface, as distinguished from lateral erosion by stream (or wave) action. Hydraulic problems are attributed to local scour at about 50 sites, to general scour at about 55 sites, and to lateral erosion by stream action at about 105 sites.

Problems at piers occurred at about 100 sites and problems at abutments at about 80 sites.

The performance of a countermeasure is rated mainly on how well it served its intended function, but also with regard to any damage it sustained and to any unwanted effects it may have produced. According to the “principle of expendability,” a countermeasure that serves its purpose most economically is likely to be damaged.

8.8.4 Brown, S. A., Mcquivey, R. S., Keefer, T. N., March 1981, “Stream Channel Degradation and Aggradation: Analysis of Impacts to Highway Crossings.”

The Parameters that Influence Grade Changes Most:

- 1) design discharge,
- 2) channel roughness,
- 3) energy slope,
- 4) bed slope,
- 5) velocities,
- 6) shear stresses,

- 7) cross-sectional geometry,
- 8) base level,
- 9) flow depth, and
- 10) flow alignment.

Methods for Determining Grade Changes

The simplest techniques are qualitative in nature involving the application of geomorphic concepts but they indicate the direction of a grade change and the potential severity of a given problem. The quantitative magnitude of aggradation or degradation to be expected in the vicinity of the highway crossing can be estimated rather quickly by analyzing the potential bed-material volume changes in the local reach. Knowing the rate at which sediment is transported in and out of the reach will provide the information needed to calculate the change in streambed elevation. Quantitative techniques are also documented for application to specific situations such as degradation downstream of dams, aggradation upstream of dams, and aggradation in streams caused by overloading.

The most complex techniques involve the analysis of entire drainage systems using detailed dynamic computer modeling of water and sediment transport processes. Analysis of stream gauging station trends provides useful information on long-term trends, such as information on suspended sediment load and shifts in rating curves.

Cost and Level of Effort (Level of Analysis)

The choice of an appropriate level of analysis must be based on available time, manpower, and financial resources. These are influenced heavily by the economic importance of a particular highway crossing as determined through risk analysis (Figure 8.23).

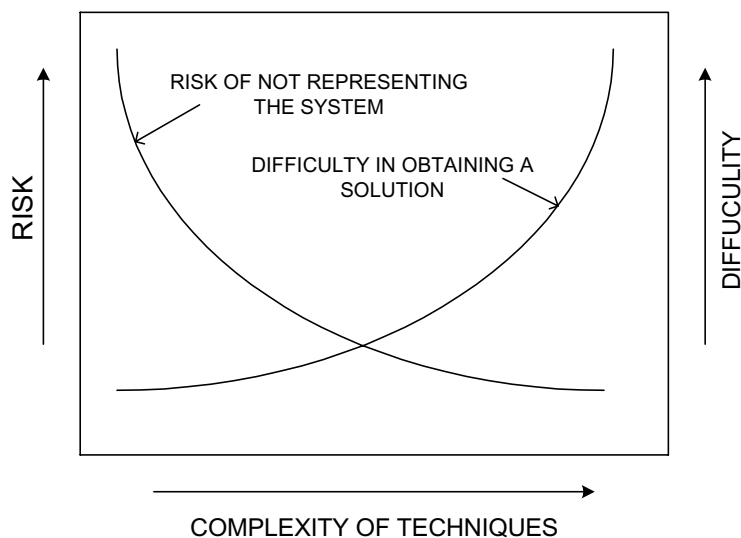


Figure 8.23. Risk and Difficulty versus Complexity.

Application of Methods; General Outline Recommended against Gradation Problems

(1) First step potential for or the existence of a grade change problem:

- obtain background information/data,
- analyze information data, and
- draw conclusion with respect to stability.

(2) Second step magnitude of the grade change:

- determine the level of analysis,
- acquire additional data,
- assess further stability considerations,
- analyze grade change, and
- analyze other impacting activities.

(3) Final step:

- evaluate the impacts on crossing design,
- select an appropriate countermeasure, and
- evaluate other impacting factors at the crossing.

8.8.5 Brown, S.A., 1985, “Streambank Stabilization Measures for Highway Stream Crossings Executive Summary.”

This report provides guidelines for the selection and design of flow control and streambank stabilization structures.

1. Streambank Stabilization Measures for Highway Engineers:

The dynamics of streambank erosion include consideration of soil displacement mechanisms and streamflow dynamics.

(A) Important soil particle displacement mechanisms:

- 1) streamflow-induced shear stresses,
- 2) surface weathering,
- 3) abrasion,
- 4) wave erosion, and
- 5) chemical action.

(B) Factors influencing the magnitude and rate of streambank erosion:

- 1) channel-flow conditions,
- 2) channelbank composition,
- 3) channelbank vegetation, and
- 4) channelbed stability.

(C) Methods of controlling streambank erosion:

- 1) provide an armor layer on the bank,
- 2) provide flow retardance along the bank,
- 3) shift the primary flow current away from the control device, and
- 4) relocate the roadway or bridge.

(D) Types of countermeasures for streambank stabilization:

- 1) spurs,
- 2) bank revetments,
- 3) retardance,
- 4) longitudinal dikes, and
- 5) bulkheads.

(E) Selection criteria of an appropriate countermeasure type against bank erosion/channel instability problems:

1) Structure function or purpose:

- protection of an existing bankline,
- reestablishment of some previous or new flow alignment, and
- flow control and/or constriction.

2) Erosion mechanism:

- streamflow-toe attack,
- streamflow-bank surface attack,
- surface weathering,
- abrasion,
- subsurface flow,
- wave erosion, and
- chemical action.

3) River characteristics:

- channel (width),
- channelbank characteristics,
- channelbed environment,
- channelbed radius,
- channel hydraulics, and
- ice and debris loadings.

4) system impacts,

5) vandalism,

6) maintenance,

7) construction-related factors,

8) legal consideration, and

9) cost.

2. Design of Spur-Type Streambank Stabilization Structures

This report provides guidelines for the application and design of spur or jetty-type flow control structures.

(A) The purpose of spur:

- 1) altering flow direction,
- 2) providing channelbank protection,
- 3) inducing deposition, and
- 4) reducing flow velocities along the channel bank.

(B) General criteria for the applicability of spurs:

- 1) Spur-type structures are not well suited for use on channels with width less than 150 ft.
- 2) Spur-type structures are well suited for use at sites where the bend radius is less than 350 ft.
- 3) Most spur-type structures are best suited for protecting channel banks with heights less than 20 ft.
- 4) Spurs are well suited for use along steep-cut and irregularly shaped channel banks where other countermeasure types would require significant site preparation.
- 5) In relation to the use of spurs in various river sediment environments, individual spur types have been used successfully under virtually all sediment environments. However, their design is more critically dependent on the channel's sediment environment than that of other countermeasures.
- 6) Spurs can pose a hazard to recreational uses of the river in some cases.

(C) Spurs classified by functional type:

- 1) retardance spurs – permeable structure:
 - fence type (wood or wire) and
 - jack/tetrahedron
- 2) retardance/diverter spurs - permeable structure:
 - light fence (wood or wire) and
 - heavy diverter.
- 3) diverter spurs – impermeable structure:
 - hardpoints and
 - transverse dike spurs.

(D) Factors important to the selection of a specific spur type:

- 1) spur function or purpose,
- 2) erosion mechanism countered,
- 3) sediment environment,
- 4) flow environment,

- 5) bend radius/flow environment, and
- 6) ice and debris conditions.

(E) Considerations in addition to above listed:

- 1) cost,
- 2) channel size,
- 3) channelbed fluctuations,
- 4) vegetation,
- 5) channel geometry impacts,
- 6) aesthetics,
- 7) vandalism and maintenance, and
- 8) construction-related impacts.

(F) Listing of design recommendations for spur-type structures:

- 1) permeability,
- 2) extent of channelbank protection,
- 3) spur length,
- 4) spur spacing,
- 5) spur angle/orientation,
- 6) spur system geometry,
- 7) spur height,
- 8) spur crest profiles,
- 9) channelbed and channelbank contact, and
- 10) spur head form.

8.8.6 Hanson, G. J., Lohnes, R. A., Klaiber, F. W., 1986, “Gabions used in Stream-Grade-Stabilization Structures: A Case History.”

The gabion grade-stabilization structures have shown satisfactory structural performance throughout the two-year observation period, with minimal differential setting and no evidence of side-slope instability since construction was finished. It should be recognized that the maximum flow to date has been less than 15 percent of the design flow.

The major amount of sedimentation occurred during construction and is likely to extend at least 5,500 ft upstream of the structure. A more optimistic estimate is that the depositional wedge will extend 6,500 ft upstream. In any event the sedimentation effects of the structure will not submerge the nickpoint that exists upstream, so continued erosion problems are likely upstream of the sedimentation area.

The sedimentation beneath the bridge has been sufficient to cover the piles to their original depth of soil cover and to stabilize the slope beneath the abutment. Erosion downstream of the structure could be a problem, especially if it undermines the stilling basin. However, the gabions are deformable and may collapse into any scour hole that forms, thereby becoming somewhat self-protecting. This downstream erosion is the result of inefficient energy dissipation by the stilling basin. An analysis of the cost of the gabion structure as compared with costs of four concrete

structures included the size, drainage area, and design flow of each of the structures is about 20 percent of that of an equivalent concrete structure.

8.8.7 Lafayette, R. A., Pawelek, D. W., 1989, “New Revetment Design Controls Streambank Erosion.”

A watershed condition analysis of the Bluewater Creek watershed near Grants, New Mexico, showed that although most of the uplands were in at least satisfactory condition, stream channel meandering cutting continued to provide excessive sediments to the fluvial system. An innovative revetment system eventually solved the problem.

The revetment consists of two elements: one or more main segments aligned parallel to flow, and a series of baffles oriented perpendicular to flow, extending from the main segment bank into the streambank. The structures functioned flawlessly capturing significant sediment deposits and small woody debris. Vegetation growth in and around the structures did well, providing additional flow roughness to enhance sediment capture and provide ground and banks cover.

8.8.8 Michiue, M., Hinokidani, O., Suzuki, K., 1989, “Simulation and Countermeasure against Bed Degradation and Aggradation in River Channel.”

In this paper, some countermeasures to stop extreme bed aggradation and degradation in the river channel are proposed, and researchers developed a numerical model to evaluate them.

The excavation of bed sediment is a useful countermeasure against extreme bed aggradation in the downstream region. It was found that it is necessary to continue to dredge the sediment of the river channel every year even after excavation to keep the bed level constant with the design bed level.

To prevent extreme bed degradation, a series of consolidation works is an effective countermeasure. The construction locations and times of various consolidation works were determined from the numerical simulation, which allowed a maximum bed level difference of two meters between the bed level and the design bed level.

8.8.9 Pagan-Ortiz, J. E., “Stability of Rock Riprap for Protection at Toe of Abutments at Flood Plain.”

The location of the most critical failure zone on an abutment encroaching the free flow of water on an armored flood plain depends on the abutment shape. For the vertical-wall abutment model, the critical failure zone occurs at the upstream corner of the abutment and expands downstream toward the abutment and away from the toe with time and increase in discharge. For the spill-through model, the critical failure zone is located downstream of the contraction near the toe and “grows” downstream and upstream of the constriction, expanding to the toe and away from the abutment.

The turbulence of flow and vorticity generated near the face of the abutment are the causes of rock riprap failure. The velocities diminish in intensity and stabilize as distance from the toe of the abutment increases.

The recommended rock riprap thickness should be equivalent to two times D_{50} . The average velocity in the flood plain within the constricted section should be used.

The velocity multipliers found in this research for the vertical-wall and spill-through abutments respectively can be applied to the velocity term in the Isbash equation for sizing a stable rock riprap size for abutment protection.

8.8.10 Richardson, E. V., Simons, D. B., 1984, “Use of Spurs and Guide Banks for Highway Crossings.”

Spurs and guide banks are effective methods of protecting bridge abutments from scour, maintaining and improving the alignment of a stream, stabilizing and maintaining a stream in a given location, and improving the hydraulic characteristics of a bridge opening to increase its flow-passing ability and to decrease scour.

Spurs can provide narrow, more consistent braided channels with zero or small angle of attack of the flow on the pier and abutments; this decreases cost. For meandering channels, spurs can stabilize a longer reach of river and prevent meander loops from moving down and eroding the abutments or approach embankments.

Spurs may decrease the cost of protecting banks by eliminating or decreasing the amount of riprap needed to protect banks on river crossings or encroachments.

Guide banks provide a more efficient flow of water through a bridge opening. They also decrease scour depth and move the scour energy away from the abutments.

This paper describes design procedures of spurs and guidebanks, according to stream form, angle of the structure to the bank, shape and form, length, spacing between spurs, construction materials, riprap design, crest elevation, top width and cross-section, and scour.

8.8.11 Shen, H. W., Wang, S. Y., 1984, “Analysis of Commonly Used Riprap Design Based on Extended Shields Diagram.”

To facilitate riprap size selection, several commonly used riprap design guides presented by the U.S. Army Corps of Engineers (for shore protection), the U.S. Bureau of Reclamation (for bank protection), and the California Department of Transportation (for both shore and bank protection), as well as guides from projects sponsored by the FHWA (for energy dissipators related to both culverts and channels) are analyzed. It was found that all these design guides are compatible and agree with the extended Shields incipient motion diagram for large sediment sizes.

8.8.12 Stevens, M. A., Simons, D. B., Richardson, E. V., 1984, “Riprap Stability Analysis.”

A method of determining the size of riprap to protect highway embankments along or across rivers is developed. The method takes into consideration the forces tending to move the particle (lift and drag of the fluid and the component of submerged particle weight in the direction of the movement) and the resisting force (submerged particle weight in a direction opposing motion). The method involves calculating SF of the riprap, which is defined as the ratio of the moment of the forces resisting motion to the ratio of the moment of the forces producing movement. It is shown that the maximum safety factor for dumped riprap is $\tan\phi/\tan\theta$, where ϕ is the angle of repose of the riprap and θ is the slide slope, and this maximum occurs when there is no flow.

9. RESULTS OF SURVEY

9.1 INTRODUCTION

Researchers carried out to investigate the opinions and current practices of departments of transportation engineers and Federal Highway Administration engineers of most of the states in the country. The survey focused on collecting information and documentation on the methods, procedures, and design guidelines used, adopted, and/or developed by these agencies to predict and measure stream instability, i.e. lateral channel migration and vertical channel degradation, and the design of countermeasures. A letter was written to the geotechnical and/or hydraulic engineers of these organizations (Figure 9.1).

9.2 ANALYSIS OF THE RESPONSES

A detailed analysis of the responses reveals valuable information that may be very helpful for the current research project. For example, a large number of responses tell us about the problem prevalence. Table 9.1 gives a list of the states that responded. At the same time little actual documentation turnout reveals that there may not be enough record of experience, current practice, or success and failure. Eleven responses out of 52 included some papers and/or reports, etc. Other responses summarized their practice in a detailed e-mail. Still others do not contain much information at all.

Table 9.1. States Who Responded.

1	Alaska	11	Massachusetts	21	Ohio
2	Arizona	12	Michigan	22	Oklahoma
3	Arkansas	13	1 Minnesota	23	South Carolina
4	Colorado	14	Mississippi	24	South Dakota
5	Delaware	15	Missouri	25	Texas
6	Georgia	16	Nebraska	26	Utah
7	Illinois	17	New Hampshire	27	Virginia
8	Iowa	18	New Jersey	28	Vermont
9	Kansas	19	New Mexico	29	Washington
10	Maryland	20	North Carolina	30	West Virginia

September 15, 1999

Mr. Goodroad
Sharp DOT
Wellbridge, H2O 550

Dear Mr. Goodroad,

We are starting a research project for the Texas Department of Transportation entitled: "Develop Guidance for Design of New Bridges and Mitigation of Existing Sites in Severely Degrading and Migrating Streams". The first part of this project calls for a synthesis of practice on:

- identifying stream instability during design of new bridges
- selecting new stream crossing sites in severely degrading and migrating streams
- assessing stream stability and countermeasures for stream instability

In the process of collecting information on these topics we are to obtain any guidance documents, tools to aid in the design of countermeasures for stream instability at existing and proposed stream crossings, and economic risk analysis tools. We are also to identify all ongoing research and to find out what problems remain largely unsolved.

I would really appreciate if you could share with us any guidance documents or other information on practice and research efforts related to vertically degrading and laterally migrating streams (as it affects bridges) including assessment, countermeasures, economic risk analysis, and on-going research. If you prefer, you can call me at 409-845-3795 or email me at briaud@tamu.edu.

If you would like to receive a copy of the results of this study please let us know.

Best wishes,

Jean-Louis Briaud, PhD, PE
Spencer J. Buchanan Professor

Copy: Mr. Tom Dahl, TXDOT.

Figure 9.1. Sample Letter Written to DOT and FHWA Engineers.

A further analysis of the responses reveals the following facts as presented in Table 9.2 and 9.3. The large number of responses indicates the prevalence of the problem. Out of 30 states that responded, 24 said they have this problem in their respective states. These states provided valuable information that will be important for our research. Only two states said there is no appreciable problem in this regard. Other states do not have enough data to provide. Most of the states use FHWA publications and guidelines for predicting and measuring stream instability and designing appropriate countermeasures. However, some states use guidelines developed by other organizations like AASHTO. Still others are using guidelines developed by themselves. That number is small though. But it is interesting to note that some states are conducting similar researches to develop their own guidelines. This indicates region specific aspects of the problem and the need for similar research for Texas. A list of the similar ongoing projects is given below in Table 9.3.

Table 9.2 Number of Responses.

Total no. of responses	52
No. of states responding	30
No. of organizations respondeding	33
No. of DOTs respondeding	30
No. of states having similar problem	24
No. of states having no such problem	2
No. of states having own design guidelines	4
No. of states using design guidelines developed by others	18
No. of states conducting research on this problem	9

Table 9.3 Summary of Responses.

Serial No	Name of the State	Problem encountered?	Own design guidelines	Others Design Guidelines	Conducting Research	Conducting Other Studies
1	Alaska					
2	Arizona	Y		Y	N	
3	Arkansas	Y		Y		
4	Colorado	Y		Y		
5	Delaware	N		Y		
6	Georgia					
7	Illinois	Y	Y	Y	Y	
8	Iowa	Y	Y			
9	Kansas	Y		Y		
10	Maryland	Y	Y	Y	Y	
11	Massachusetts	Y				Y
12	Michigan	Y		Y		
13	Minnesota	N				
14	Mississippi	Y		Y		
15	Missouri	Y		Y		
16	Nebraska	Y			Y	
17	New Hampshire	Y		Y		Y
18	New Jersey	Y		Y		
19	New Mexico	Y		Y		
20	North Carolina	Y			Y	
21	Ohio	Y				
22	Oklahoma	Y		Y		
23	South Carolina	Y			Y	
24	South Dakota	Y				
25	Texas	Y				
26	Utah	Y		Y		
27	Virginia					
28	Vermont	Y		Y		
29	Washington	Y		Y		
30	West Virginia					

Y = yes, N = No, blank = data not available

9.3 ONGOING RESEARCH PROJECTS

There are at least nine similar research projects currently underway in some of the states where the problem is pronounced. The topics range from developing design guidance to improving instrumentation to measuring scour, etc. A list of these projects is furnished below.

1. Cold Region Research and Engineering Laboratory (CRREL) is conducting research on scour under ice, especially during spring melt which increases discharge maximizing degradation in Vermont and Montana. “Real Time” visual documentation is being done by video camera.
2. New Jersey: Remote Bridge Scour Monitoring Project. Investigated by Hani H. A. Nassif Ph.D., P.E., at Univ. of New Jersey.
3. New Jersey: “Water Level Prediction for Transportation Projects.” Investigated by Dr. Joshua Greenfeld, NJIT.
4. Connecticut: Feasibility of developing a statewide network of scour monitoring devices. Funded by New England Transportation Consortium and investigated by Dr. Carlton L. Ho of University of Massachusetts at Amherst.
5. Nebraska: Bridge site indexing for scour risk potential, natural and manmade causes of stream instability, and mitigation measures.
6. South Carolina: “Modeling of Channel Shift at South Carolina Bridge Crossings” by Dr. M. Hanif Choudhury at University of South Carolina.
7. Maryland: “Modification of Neil’s Equation For Tidal Flow Analysis” conducted by Dr. Kay Brubaker at the University of Maryland.
8. Maryland: “Hydraulic Control of Local Scour at Bridges” conducted by Dr. P. A. Johnson at Pennsylvania State University and Dr. R. D. Hey at the University of East Anglia.
9. Maryland: “Evaluation Scour at Bottomless Culverts” conducted by Dr. S. Jones at FHWA, Turner–Fairbanks Research Laboratory, McLean, VA.

9.4 FINDINGS

A detailed search into the survey responses and the publications furnished reveals some aspects of the present practices on stream instability prediction and countermeasure design. Some information on performance, successes, failures, and cost and construction features has also been obtained.

The experience of different states in the country is not well documented. A high reliance on past historical data and experience can be observed. The guidelines that are mostly used are those developed by FHWA and AASHTO. A few states use guidelines developed by other institutions. Still fewer states use their own developed guidelines. The guidance documents quoted by the states that responded are listed in [Table 9.4](#). Also the web sites mentioned are listed in [table 9.5](#). The findings that can be summarized from the responses are discussed in the following paragraphs.

Table 9.4. Guidance Documents Mentioned by the Respondents.

1	E. V. Richardson, D. B. Simons, et al. "Highways in River Environment," FHWA Publication No. FHWA-HI-90-016, Feb 1990 and revisions.
2	FHWA, HEC-20, Publication No. FHWA-IP-90-014, "Stream Stability of Highway Structures," Feb 1991 (and updates) along with NHI Courses No. 13046 Manual/Notebook.
3	FHWA, HEC-18, Publication No. FHWA-IP-90-017, "Evaluating Scour at Bridges," Nov 95.
4	FHWA, HEC-23, Publication No. FHWA-IP-97-030, "Bridge Scour and Stream Instability Countermeasures."
5	FHWA, HEC-11, Publication No. FHWA-89-016, "Design of Riprap Revetment," Nov 89. (and later versions)
6	FHWA, "Channel Scour at Bridges in the United States."
7	FHWA, Publication No. FHWA-HI-91-011, "Stream Stability and Scour at Highway Structures," NHI Course 13046, Participating Notebook, FHWA-HI-91-011, March 1991.
8	NCHRP Report, "Instrumentation for Measuring Scour at Bridge Piers and Abutments," Report No. 396.
9	NCHRP Report, "Sonar Scour Monitors," Report No. 397A.
10	NCHRP Report, "Magnetic Sliding Collar Scour monitors." Report No. 397B.
11	AASHTO, Highway Drainage Manual, 1992 and 1999 versions.
12	AASHTO, Model Drainage Manual, 1992 and 1999 versions.
13	U.S. Army Corps of Engineers, Omaha Districts, Design Manual, Streambed Degradation and Streambank Widening in Western Iowa, Sep 98.
14	US Army Corps of Engineers, "Channel Stability Assessment for Flood Control projects," EM 1110-2-1418.
15	Iowa DOT, Stream Stabilization in Western Iowa, Golden Hills Resource Conservation and Development, Oakland, Iowa DOT HR-352, 1994.

Table 9.5. Web Sites Searched.

1.	Federal Highway Administration web site: http://www.fhwa.dot.gov/bridge/hyd.htm
2.	New Jersey "Remote Bridge Scouring Project" web site: http://www.civeng.rutgers.edu/scour
3.	NCHRP project for developing software for bridge inspection and scour monitoring: http://maximus.ce.washington.edu/~scour/

Arkansas personnel rely more on historical experience than on specific design guidelines. To prevent stream migration, flexible bank protection is mostly used. For vertical degradation, grade control structures are used. Guide bank and spur dikes are used to minimize channel migration and alignment problems. A common practice is to design the bridge with the last pier on the bank and last span extending overland, so that in case of lateral channel shift it goes under that span. This results in a longer bridge, higher initial cost in construction, and higher maintenance cost.

In Minnesota there is no appreciable problem, therefore they could provide no data.

South Dakota respondents reported the long-term success rate of current practices to be disappointing as far as stream instability countermeasures are concerned. Sheet plate deflectors used to deflect the striking stream suffered some damage during high floods. A line of jacks was installed – but failed the first year due to ice build-up at the top. A channel cut made in the 1940s worked well for more than 40 years until recently. Now the site is under threat again. Wing dikes are also used. To mitigate the vertical degradation of smaller streams, say 50 sq. mile drainage or so, checkdams or sills are used. Vertical degradation is also mitigated by a series of checkdams and sediment traps. There are several problem locations in this state. After several different types of countermeasures were tried, answers of unresolved problems are sought. The geotechnical engineers are involved only in the exploration phase. Engineers in the hydraulic/structural divisions assess susceptibility to stream migration and degradation.

In Illinois, bendway weirs are used but no data is furnished as to their performance. In Ohio mostly rock riprap revetments are used. There are problems reported in Oklahoma. Various alternative countermeasures are used. No other information is provided. In Vermont riprap is most commonly used. The stone size depends on the stream velocity and design flow. In Connecticut there is not much of a problem. HEC-18 and 20 are used. There is not much of a problem in Delaware either. HEC 11 and 18 are reported to be very helpful. In Michigan HEC-21 and 23 are used.

In New Mexico river mining, channel straightening and other man-made activities are reported to be the main reason for degradation in natural streams.

In New Jersey, severe problems are reported. Therefore New Jersey is sponsoring two research projects.

10. ECONOMIC RISK ANALYSIS

The mission of TxDOT at stream and riverine crossings is to protect the safety of the highway users and the investment in the major highway infrastructure. Protection of the infrastructure and the users may require countermeasures when erosion of the approaches occurs or scour threatens the bridge support system. The countermeasures that are available (HEC-23) vary considerably in cost, effectiveness, range of use, and success against the intended event. The thalweg migration, scour, and streambank erosion are related to flood events, and these are random occurrences in frequency and severity. The purpose of this section is to provide information on economic risk analysis tools that are appropriate for comparison of countermeasures to stream migration and degradation including the addition of spans to structures. At the outset, it is noted that risk-based decisionmaking is a complex process because it deals with phenomena coming from many disciplines, and second is that it encompasses nearly every dimension and aspect of our lives. It is also important to distinguish the difference between risk and safety (Lowrance 1976). Quantifying risks is an empirical, quantitative, scientific activity, whereas measuring safety is judging the acceptability of risks. The project focuses on the risk aspects since the safety aspects are in the domain of political and social sciences.

When several options exist to solve a problem, it is often difficult to choose the best solution. A risk analysis can be performed to help in the decision process. Within the scope of this project, a risk analysis includes identifying the engineering options available, evaluating the cost of each one of the options, estimating the probability of failure of each of the options, and basing the decision on the combined value of the cost times the probability of failure. This type of approach is very site and problem specific, and it is only possible to give the general procedure for using such a technique in the decision process. One of the important steps in such a process is estimating the coefficients of variation of the parameters involved in the prediction method. This is, for example, the coefficient of variation of the critical shear stress as measured in the erosion function apparatus (EFA), or the coefficient of variation of the maximum velocity that is likely to be experienced by the bridge during its design life. It is proposed to evaluate what these coefficients are and to demonstrate how they can be used to arrive at a decision. As a very crude example, consider that solution A for avoiding channel migration has a cost of \$1,000,000 and a probability of failure of 0.001, and that solution B has a cost of \$1,500,000 and a probability of failure of 0.0005. The expected value of solution A is $1,000,000 \times 0.001 = 1000$ and solution B has an expected value of $1,500,000 \times 0.0005 = 750$. The comparison of the expected values leads to a more analytically based decision process; usually the lower expected value is more desirable. Nevertheless, the above example is too simple to adequately represent the complex problems associated with most bridge and highway projects. So the following presents a more realistic discussion of approaches.

10.1 RISK ANALYSIS

As early as 1975, Tseng, et al. (1975), considered bridge scour and streambank stability in terms of economic risk analysis. Their work for the FHWA demonstrated a procedure for defining the risk factors and attempting to compute the cumulative risks so the effect on long-term costs could be determined. A more generalized approach to economic risk management of civil infrastructure was

investigated by [Johnson-Payton \(1997\)](#). Johnson-Payton evaluated the impact of multiple failure modes in risk analysis using a fault-tree analysis with extreme events. Consideration was given by Small for modeling natural hazards and extreme events in bridge management systems ([Small, 1999](#)). He proposed two approaches including a rigorous risk-based procedure and a value-based approach. His work focused on the latter, and he noted that in general the required information for prioritization is not available in the current bridge inventories and inspection databases. This required extensive culling of information from available plans and missing information was assumed based on the configuration.

The [U.S. Army Corps of Engineers \(1996\)](#) presented an approach to using computer analysis tools to incorporate uncertainty in the choice of hydrologic, hydraulic and economic functions to describe the uncertainty in the parameters of the functions. The results of their proposed approach differ from the traditional statements of probability of exceedance of an alternative and the economic benefits. Instead their approach provides descriptions of the likelihood that an alternative will deliver various magnitudes of economic benefit and the expected probability of exceedance while considering the uncertainty in all the assumptions used in the computations of probability. The product of the analysis is the inundation-reduction benefit $B_{IR} = (X_{without} - X_{with})$, where B_{IR} is the benefit and $X_{without}$ is without-project economic flood-induction damage and X_{with} is the economic damage if the plan is implemented. The expected annual exceedance probability (AEP) approach is the measure of the likelihood of exceeding a specified target in any year. The AEP is a common approach in risk-based analyses involving uncertainty of input conditions. The U.S. Army Corps of Engineers also provides a detailed example for the use of AEP in the report. The example is for illustration of evaluation of economic efficiency and engineering performance accounting for uncertainty for a flood-damage reduction plan for Chester Creek, PA.

10.2 ALTERNATIVE ANALYSIS METHODS

[Haimes \(1998\)](#) gives a very thorough treatment of various approaches to modeling for risk management and decision-making. Going beyond the “simple” deterministic analysis, which is clearly not simple in the case under discussion, Hierarchical Holographic Modeling (HHM) brings into consideration the concept of risk in the parameters or variables in the problem. For example the risk may only be in developing the bounds on the annual rate of migration of the thalweg. When it is important to consider several objectives that need to be met and which are in competition, the multi-objective trade-off analysis is commonly used. This approach is frequently considered as the Multiple Criteria Decision Making (MCDM) approach. An example of competing objectives may be the desire to prevent migration by placing riprap along the shoreline, which may cause the streambed to continue degrading. Decision trees can serve both analysts and decision makers when they are extended to deal with several objectives. According to [Haimes \(1998\)](#) they are powerful tools for analyzing complex problems. They are also among the most commonly used tools in risk-based decision making. The decision tree is popular because it appears intuitive based on its reliance on both graphical and analytic presentations of the problem. The graphical component is descriptive and easy to understand while the analytic builds on Bayes’ theorem. There are also the decision tree and multi-objective decision tree approaches that will add much more realism and practicality to the solution ([Raiffa 1964](#)). An example generic decision tree is shown in [Figure 10.1](#).

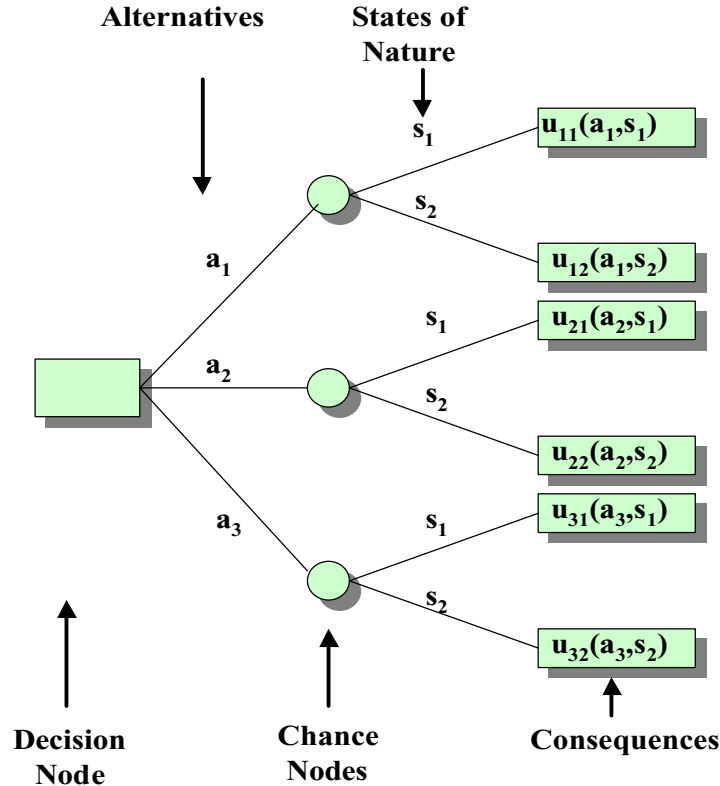


Figure 10.1. Generic Decision Tree.

The decision node is the point at which, say, the decision is made to install a countermeasure. The chance nodes represent whether the countermeasures will be weirs, riprap, or mattresses. The value of the consequences (outcomes), which may be costs, will be the result of each decision of a limb of the tree. The states of nature are the uncontrolled events or the rate of continuing migration of the streambank. This example is for a simple case, and it is easy to see how multiple decision trees could become very complex.

Although there are many additional techniques, another that is quite useful is the Multiobjective Statistical Method (MSM) (Haimes 1998). Frequently, it is more difficult to construct a risk analysis using decision vectors, \mathbf{x} , rather than in terms of state vectors, \mathbf{s} . A state vector, \mathbf{s} , is a more easily measurable condition, such as depth of degradation, rather than the measures taken to reach such a state level, \mathbf{s} . However, in the multi-objective trade-off and optimization analysis, it is much more convenient to have these functions expressed explicitly in terms of the decision vector, \mathbf{x} , rather than \mathbf{s} . The multi-objective statistical method of analysis provides a mechanism to construct the risk function in terms of \mathbf{s} and then through regression analysis or Monte Carlo simulation, the MSM regenerates these functions in terms of \mathbf{x} , the decision variables.

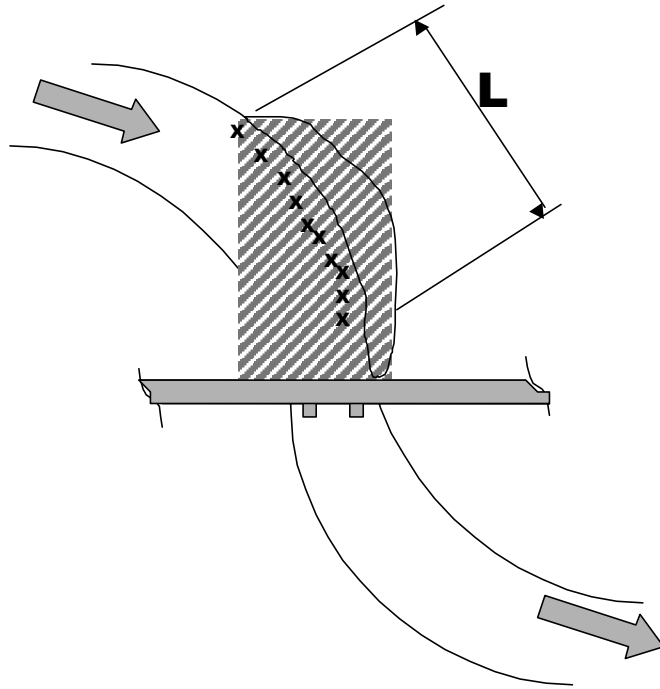


Figure 10.2. Application of Countermeasures against Erosion Caused by Stream Migration.

The basic concept of the MSM is to use the state vector, \mathbf{s} , for computations and simulations and produce the risks in terms of the decision vector, \mathbf{x} . For example, consider defining a decision vector, say the countermeasure, $\mathbf{x} = [x_1, x_2, \dots, x_k]$, which yields the rate of migration as $E(\mathbf{x}; \eta_i, r_j)$ where $r_j \in \{1, 2, \dots, J\}$ is the river flow and $\eta_i \in \{1, 2, \dots, I\}$ is the river stage. The set of decisions \mathbf{x} could consist of (1) length, (2) type of device, (3) elevation, (4) year of installation and (5) cost and others. The two variables r_j and η_i reflect the stochastic nature of the problem. They are both likely to be described as extreme value distributions to give the statistical information for the problem.

Similarly, an additional function $D(\mathbf{x}; \eta_i, r_j)$ could be defined for degradation or local scour. Now define $\hat{\eta}$ and $\bar{\eta}$ as the minimum and maximum attainable river stage and \hat{r} and \bar{r} as the minimum and maximum volumetric flow rate, respectively. Although it is not intended that the minimum values are the absolute least values, the combinations are to represent all significant conditions that may occur over the time period $[0, T]$.

If we define the integers I , J , and N which represent the discretization over the respective intervals, then it appears that:

$$\Delta\eta \equiv \frac{(\bar{\eta} - \hat{\eta})}{I}$$

$$\Delta r \equiv \frac{(\bar{r} - \hat{r})}{J}$$

$$\Delta t \equiv \frac{T}{t}$$

Following [Haimes \(1998\)](#), define the river stage as $\eta_i = i\Delta\eta$, $i \in \{1, 2, \dots, I\}$, and the flowrate as $r_j = j\Delta r$, $j \in \{1, 2, \dots, J\}$. From this point a sequence of the decision variables, $\mathbf{x} \in \{x_1, x_2, \dots, x_k\}$ are combined by an appropriate simulation with the flowrate, r_j , and river stage, η_i , to produce the migration result $E(\mathbf{x}; \eta_i, r_j)$ and the degradation rate $D(\mathbf{x}; \eta_i, r_j)$. The simulation procedure would most likely be the Monte Carlo simulation approach. Application of this approach to a specific problem experiencing either stream migration or degradation or both phenomena requires more mathematics than presented here and would follow the approach presented by [Haimes \(1998\)](#). But, once the problem is established, it can be implemented through the software Risk that is commercially available.

11. CASE HISTORIES

11.1 SH 105 BRIDGE OVER THE BRAZOS RIVER, BRYAN DISTRICT

We wish to thank Mr. Pat Williams and Mr. Terry Paholek of the Bryan District (TxDOT) for taking the time to show us the Navasota River Bridge site and for sharing with us their opinions and TxDOT data.

11.1.1 Location, River, and Bridge Description

The SH 105 crossing of the Brazos is located about 5 miles west of Navasota, Texas, and about 1/4 mile west of the intersection of FM 159 and SH 105. The bridge is located just about one mile upstream of the confluence of the Brazos and Navasota rivers. Aerial photos of the crossing were taken in 1969, 1978, 1988, and 1999. The 1988 aerial photograph (Figure 11.1) shows that the Brazos River was almost perpendicular to the SH 105 bridge crossing. Several hundred feet upstream of the crossing, however, the river forms a major bend that approaches from the east.

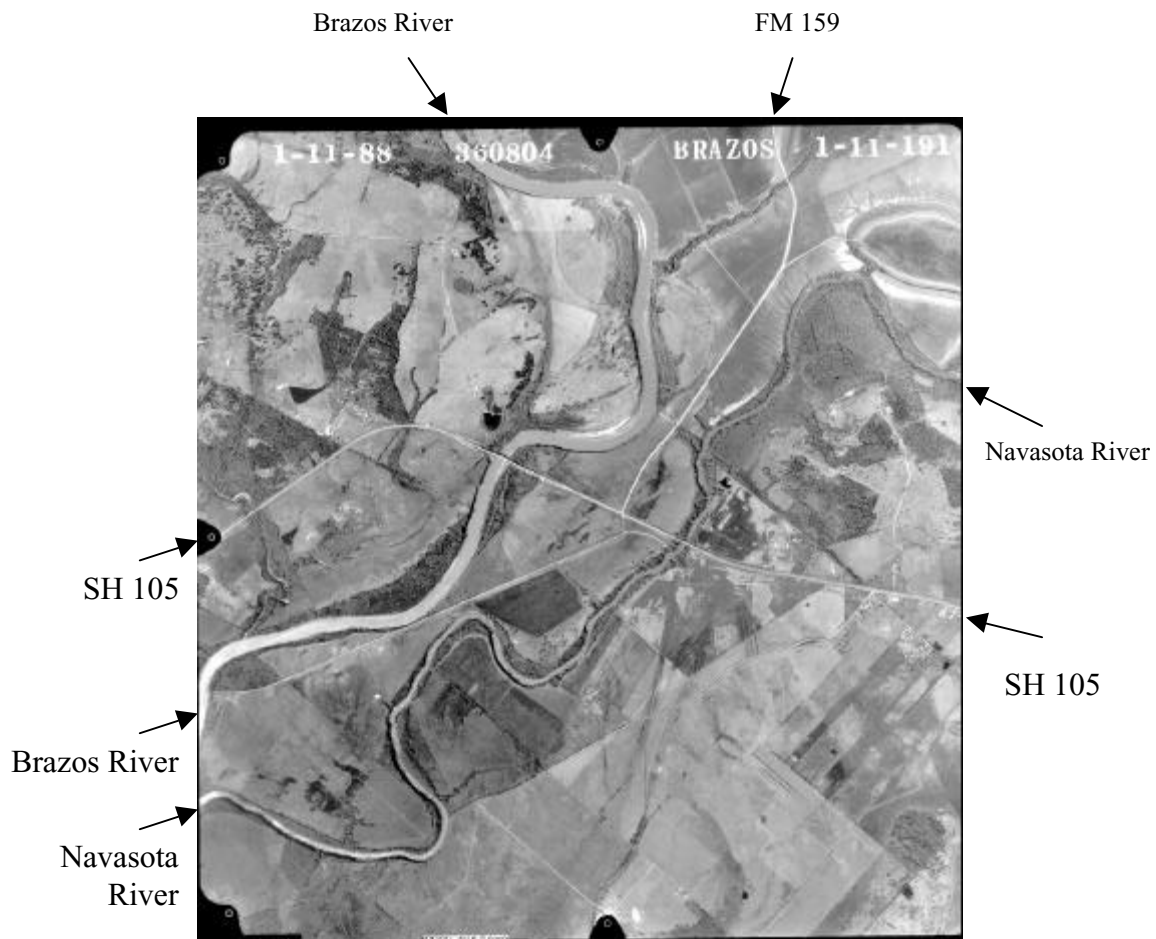


Figure 11.1. 1988 Aerial Photo of the Site.

11.1.2 Hydrograph

USGS Gauging Station No. 08109000 is located upstream of the site on the Brazos River near Bryan. The gauging station contains 95 years (1900-1995) of historical streamflow data. The watershed above the station has a drainage area of about 39,515 square miles. The gauge analysis shown below was based on 95 years (1900-1995) of historical streamflow data:

Probability	Frequency (years)	Discharge (cfs)
0.99	1	3,500
0.50	2	45,400
0.20	5	57,900
0.10	10	108,500
0.04	25	148,900
0.02	50	182,800
0.01	100	219,600

11.1.3 Soil Type

The 1951 soil survey conducted by U.S. Department of Agriculture showed that the soil at the site is a combination of Miller and Norwood soils. The Miller series soils are made up of relatively recent sediments that were deposited by flood waters of the Brazos River and that may occasionally be flooded. The soils of the Norwood series were developed in relatively recent sediments deposited by floodwaters of the Brazos River and are rarely flooded.

11.1.4 History of the Problem

Over the past 30 years, the channel upstream of the bridge has migrated about 400 feet towards the SH 105. The channel appears to be fairly stable between 1969 and 1988 with only about 100 feet of lateral migration over this period. Over the past eleven years (1988-1999), however, the channel migrated at a much faster rate towards the SH 105 bridge crossing. The movement is occurring upstream of the crossing at the first bend of the main channel. There is also an associated slide on the west bank which was believed to be aggravated by a large stock pond. In addition, there is a large meander to the north of the bridge. The meander is moving south and east, and a considerable amount of the overbank has been lost upstream of the bridge. The lateral channel migration can be clearly seen from the 1969 and 1999 aerial photographs shown in [Figure 11.2](#). [Figure 11.3](#) shows a detailed sketch by George Odom of TxDOT drawn from aerial photographs taken in 1969, 1978, 1988, and 1999.



Figure 11.2. Channel Migration between 1969 and 1999.

TxDOT DESIGN DIVISION	County <i>Brazos</i>	Design <i>GHD</i>	Date <i>7/99</i>
	Hwy <i>SH 105</i>	C-S-J	Ck Dsn
	Design for <i>Brazos River</i>		Date
		Sheet	of

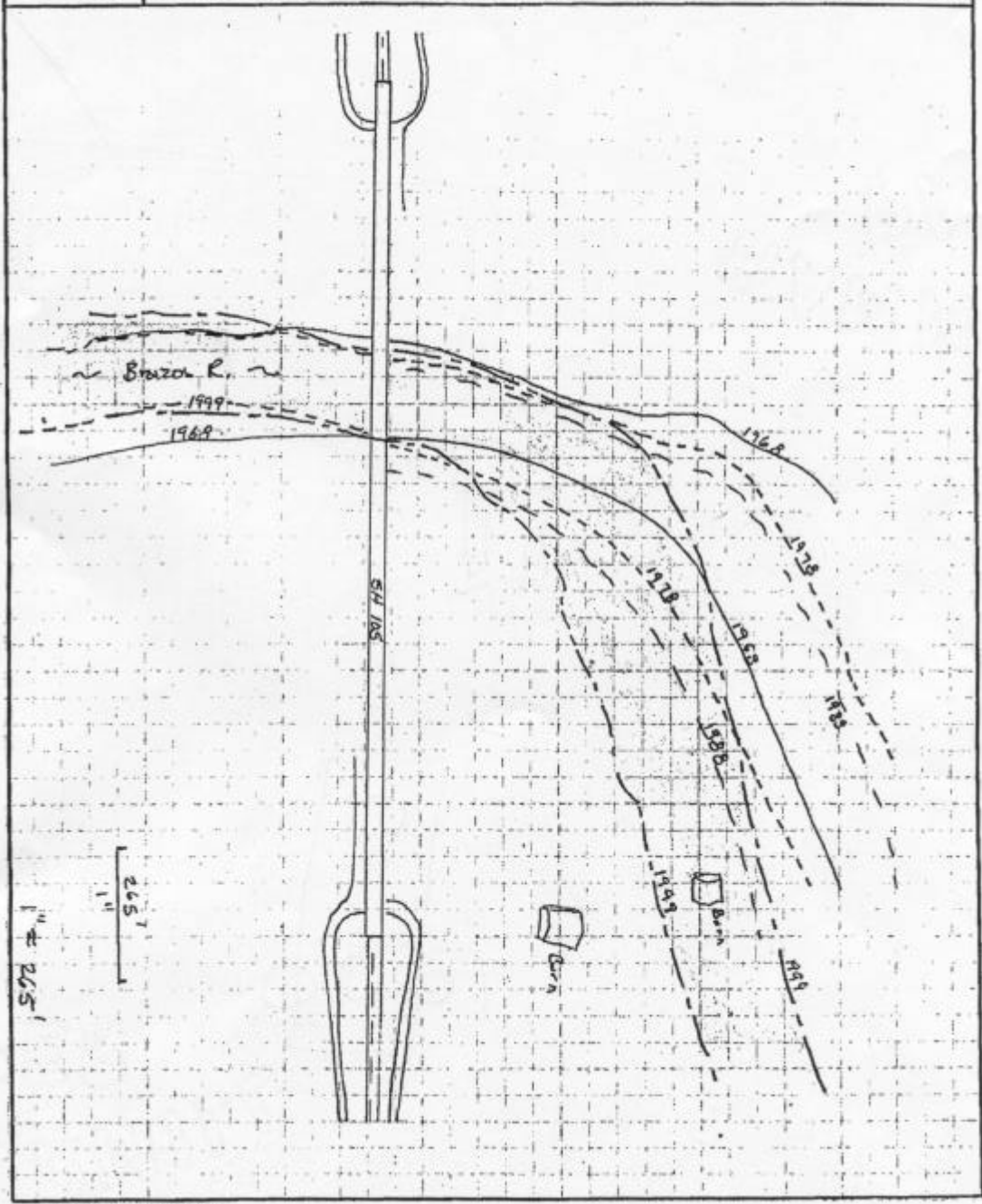


Figure 11.3. Sketch of Channel Migration.

11.1.5 Countermeasures

Significant movement was observed at pier no. 50 located on the west bank. In 1994, the original pier was replaced by a double-column pier as shown in [Figure 11.4](#) to correct the problem. However, the pier movement problem is not directly related to the channel migration problem on the east bank of the Brazos River near the bridge crossing ([Figures 11.5](#) and [11.6](#)). The TxDOT Bryan District is planning to monitor the channel migration at the site, but there was no other countermeasure in place at the time of our visit in November 1999.



Figure 11.4. Pier No. 50 on the West Bank of the Brazos River.



Figure 11.5. Site Photos.



Figure 11.5. Site Photos (continued)

11.2 U.S. 90 WESTBOUND MAIN LANE BRIDGE OVER THE NUECES RIVER, SAN ANTONIO DISTRICT

We wish to thank Mr. John Kilgore for taking the time to show us this bridge site and for sharing with us his opinion and the data from the TXDOT.

11.2.1 Location

The U.S. 90 crossing of the Nueces is located about six miles west of Uvalde, Texas, and about 88 miles west of San Antonio (Figure 11.6). It consists of a west bound bridge and a relief structure which were constructed about 1967, and an older east bound bridge and relief structure.



Figure 11.6. U.S. 90 Bridge and Relief Structure at the Nueces River.

11.2.2 Bridge and River Description

The 1960 topography published by the U.S. Geological Survey (Figure 11.7) shows that the Nueces River main channel is almost perpendicular to the U.S. 90 crossing. Along the west bank within the main channel, there is a low flow channel that also approaches the crossing perpendicularly. About 3/4 mile upstream of the crossing, the river forms a major bend that approaches from the west. Similarly, the river takes a major turn to the east about 3/4 miles to the south of the crossing. The bridge is at an ideal location about midpoint of the 1.5-mile straight section between the two bends.

As noted by David Stolpa of TxDOT Hydraulic Section in his memorandum dated April 29, 1999, the 1960 topographic contours reveal the probable location of old abandoned river channels in the vicinity of the U.S. 90 bridge crossing. The parallel relief structures appear to be located over one of the old abandoned channels just to the west of the main bridges. The contours in the vicinity of the relief structures indicate the possibility that the abandoned channel once formed the apex of a major meander at the bridge site. It appears that the main channel was forced to shift to its present location because the eastern limits of the floodplain were not as stable and well defined as the western boundary.

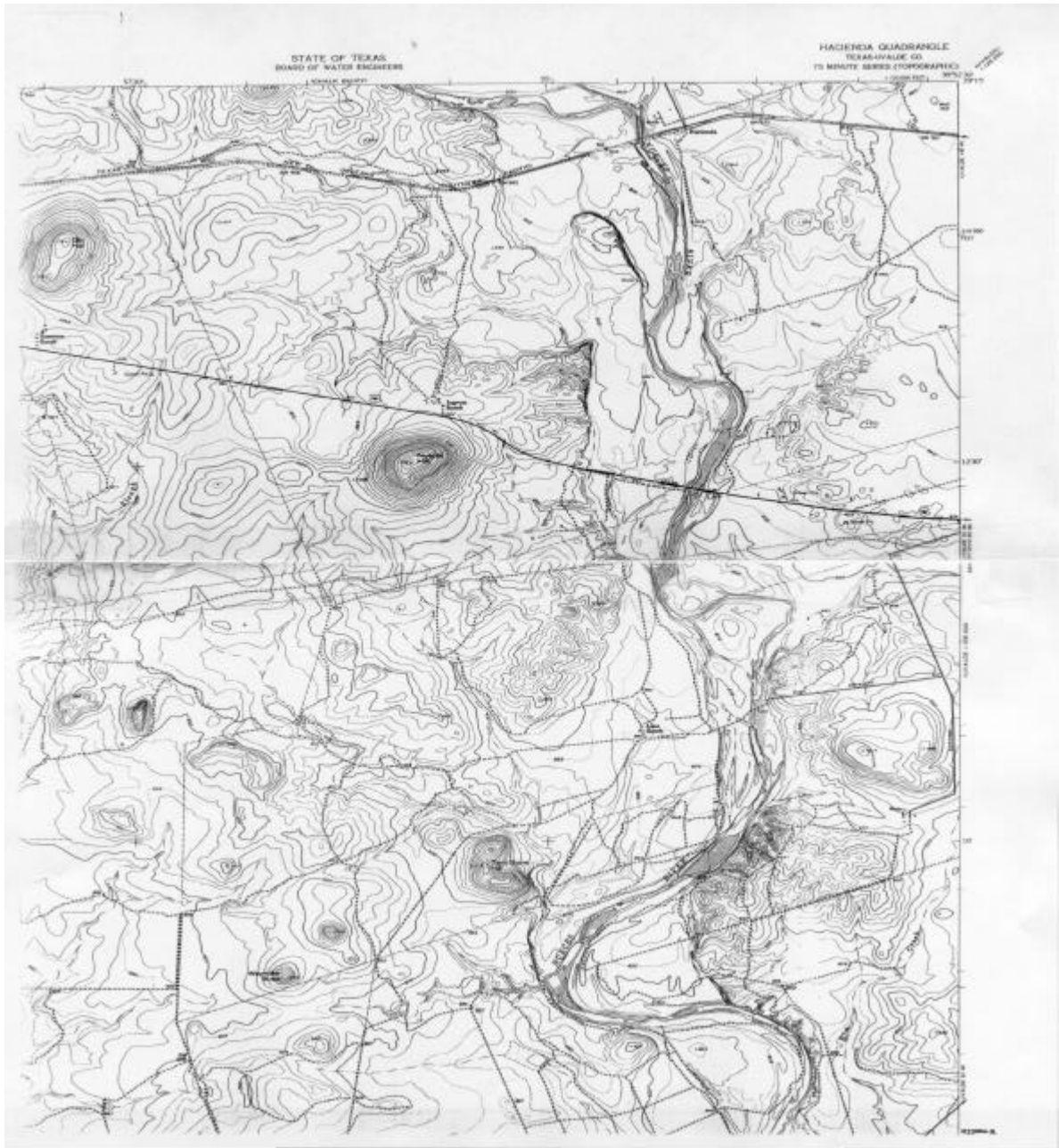


Figure 11.7. 1960 Topography of the Nueces River.

11.2.3 Hydrograph

USGS gauging Station No. 08192000 is located just a few miles downstream of the site on the Nueces River. The watershed above the station has a drainage area of about 1861 square miles. The gauge analysis shown below was based on 66 years of systematic data:

Probability	Return Period (yrs)	Discharge (cfs)
0.50	2	11,600
0.20	5	46,600
0.10	10	90,900
0.04	25	177,000
0.02	50	266,000
0.01	100	378,000

11.2.4 History of the Problem

Bridge performance at the site appears to have been satisfactory until recent years when an apparent shift in the river and degradation of the streambed became noticeable about 1996. Recent flooding apparently has resulted in severe lateral migration as well as vertical degradation of the main channel. The extent of channel migration can be seen from the aerial photographs shown in Figures 11.8 and 11.9. The most recent extreme event shown in Figure 11.10 occurred during the period of August 24-26, 1998, when the river experienced a sharply defined flood peak of about 82,000 cfs followed about 30 hours later by a second peak of roughly 68,000 cfs. Subsequent flooding also resulted in the failure of the concrete riprap of the west abutment of the West Bound Main Lane (WBML) Bridge and threatened the west abutment of the East Bound Main Lane (EBML) Bridge. This damage was contained and repaired by placement of a rock berm along the damaged reach.

Inspection of the U.S. 90 EBML Bridge over the Nueces River by Michael B. Raspbury on September 2, 1998, found significant problems with the substructure foundation due to stream instability and channel degradation. The western bank of the river had shifted to the west approximately four span lengths (about 180 ft) since the previous inspection in April 1996. Also the channel had degraded approximately 4 ft to 5 ft at its deepest point based on a comparison to the 1996 channel profile measurements. The combination of channel shifting and degradation reduced the depth of the original foundation up to 15-ft at the west approach bents (Bent Nos. 8-12 from the east). The bridge inspection records classify the bridge as having high susceptibility to scour and show that a scour evaluation had not yet been done at the time of the 1998 inspection. After the inspection, it was recommended to take the following actions:

1. Re-classify the bridge as a “Known Scour Problem.”
2. Perform a Concise Analysis to determine whether the remaining embedded foundations at Bent 6 through Bent 12 (from the east) are adequate for the 100-yr flow conditions.

3. Consider installing countermeasures such as rubble riprap at the west approach bents to protect against further scour or degradation.
4. Consider countermeasures for stabilizing the west bank in coordination with remedial measures to be undertaken for the west bank of the U.S. 90 WB structure. The west bank has shifted approximately 180 ft to the west from April 1996 to September 1998, which suggests that further movement should be expected.



Figure 11.8. U.S. 90 Bridge at the Nueces River –Looking Northwest.



Figure 11.9. Nueces River North of U.S. 90 Bridge (Relief on Right Side)–Looking South.

11.2.5 Countermeasures

According to the memorandum prepared by David Stolpa on April 29, 1999, there was an apparent development of a meander in the river towards the west abutment. The photographs show that the abutment and about 500 feet of embankment separating the main channel bridges from the relief structures were under attack. As seen in [Figure 11.11](#), the river actually seems to be heading in a direction towards recapturing the old channel that is now crossed by the relief bridges. The photos also clearly show the subsequent development of what was once a lateral bar, at the east bank, into a point bar along the inside of the meander. This new bar development, along with the horizontal resistance of the west abutment, appears to be forcing a situation for which the river can currently compensate only by attacking the streambed at the west abutment. Thus, a scour/degradation threat also appears to continue for the drilled shafts of the Bents 7 through 10.

The district constructed a rock riprap protection to prevent additional exposure of the drilled shafts. The new rock berm has stabilized the situation for the time being. Several countermeasures were discussed concerning the long-term response to the problem. Basically, the options were: 1) to try to contain and manage the river, 2) harden the west abutments of the two parallel main bridges and monitor them, and 3) span the intervening embankment between the main and relief bridges, and let the river determine its course. David Stolpa recommended in his memorandum dated April 29, 1999, that the Hydraulic Section support Option 3 as the long-term solution to the problem at the site. Bridging the intervening embankment was judged to be the most cost-effective approach that could provide safe operation of the road even if this section of the U.S. 90 WBML structure comes under renewed attack.



Figure 11.10. 1998 Flood.



Figure 11.11. Nueces River South of U.S. 90 Bridge – Looking North.

11.3 TRINITY RIVER – BEAUMONT

We wish to thank Mr. Robert Balfour of the Texas DOT for taking the time to show us the Trinity River site and for sharing with us his opinion and TxDOT data.

11.3.1 Location

The Trinity River flows through San Jacinto, Polk, Liberty and Chambers counties after leaving Lake Livingston and before flowing into Galveston Bay. Specific concerns for this study are where significant migration and erosion has occurred at Highways 787 and 105. At both of these sites significant repairs and mitigation measures have been initiated. At both sites the roadway approach is adequately higher than the rivers normal and flood stages. [Figure.11.12](#) shows Trinity River at Highway 787 and location of countermeasures installed.

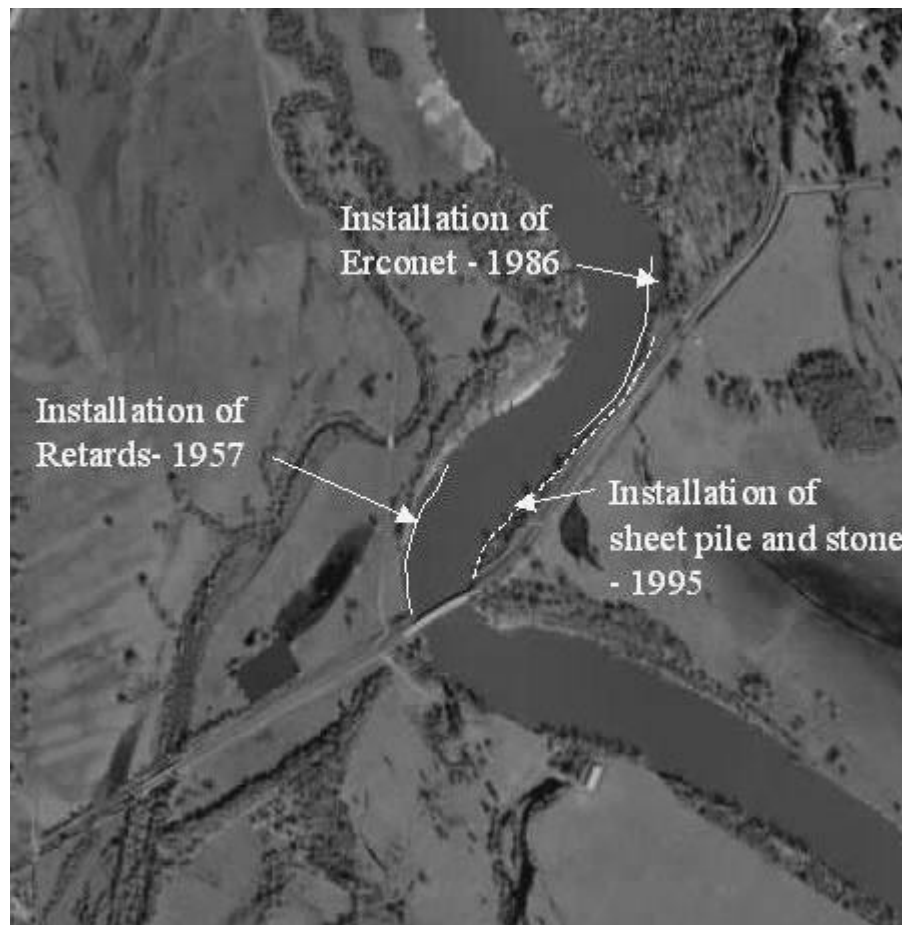


Figure 11.12 Trinity River at Highway 787.

11.3.2 Bridge and River Description

At the Highway 787 site, the typical flow is approximately 1000 cfs and it can increase within a day to 110,000 cfs when there are floodwater releases from Lake Livingston. The spillway at Lake Livingston is less than 20 miles from Highway 787 and approximately 40 miles from Highway 105. The 50-year maximum flow rate at this site is 117,500 cfs and the 100-year maximum flow rate is 132,000 cfs. The average channel velocity during the fifty-year event would be approximately 3.51 fps and 3.7 fps for the 100 year event. Through the bridge the 100-year flood would create a velocity of 9.7 fps according to [TxDOT \(1975\)](#).

11.3.3 History of the Problem

Serious erosion was noted in 1957 when the first remedial action was undertaken. It was observed that on the western side of the river extensive erosion was occurring at the bend immediately upstream of the bridge. More importantly, the erosion was observed to be advancing toward the bridge. Later, in 1986 ([TxDOT 1986](#)), measures were taken to control the erosion problem on the eastern side of the river upstream of the bridge. The erosion became a problem because of the encroachment of the river on the right of way of Highway 787 coming from Romayer, on the east approach to the bridge. The height of the approach above the water and the steep embankment caused concern as the shoreline rapidly moved toward the roadway. The original construction to prevent the eastern side of the river from encroaching on the roadway was found to be no longer effective in 1985 and a remedial measure was added. This too has failed in several locations, one of which is shown on [Figure 11.13](#) below. In 1998, construction was completed to replace the two bridge pile bents with drilled shafts in response to the general and local scour around the pile bents. At the time of construction the scour had progressed over 25 feet from the original riverbed at the eastern pile bent ([TxDOT 1998](#)).



Figure 11.13. Failure of the Sheet Pole Wall as a Countermeasure.

11.3.4 Countermeasures

At this site several countermeasures have been undertaken with varying degrees of success. In 1957 the first countermeasure was placed on the western bank of the river to protect the shoreline from erosion. The measure covered approximately 1600 ft of shoreline with a type of “jetty,” each of which was about 120 ft long. These were composed of six-legged jacks placed in a line at a forty-five degree angle upstream. The jacks were then connected by cable and tied ashore to form the jetty. It is assumed that the jacks were made from steel. The system was called a “retard.” None of the retards were evident when the site was visited on November 15, 1999, although the anchor piles on land were visible. It is not clear that the measure was effective. It is most likely that the majority of the devices were moved during flood events.

In 1986, a countermeasure was installed on the eastern bank of the Trinity River upstream of the Highway 787 approach to the bridge. The device used was an “Erconet Palisades.” The Erconet consisted of steel pilings placed on 16 ft centers and connected with a cross-weave polyester strap woven into a square mesh. This was placed along approximately 2500 ft of riverbank. It is believed that these were placed at the edge of the normal water elevation. Currently there is a remnant of the device in the water. Many of the piles are still there and some of the Erconet is still draped on the piles. An example of this is shown in [Figure 11.14](#) looking upriver. Some of the piles for this also appear to have been placed immediately upstream of the bridge on the western side of the river.



Figure 11.14. Erconet Palisades as Countermeasures.

The last remediation took place in 1995 on the eastern bank of the Trinity River, immediately upstream of the bridge and extending for approximately 2400 ft. This construction consisted of placing 40,000 ft of PZ-27 sheet piling fronted by 2080 cubic yards of 18-inch stone and 1175 cubic yards of backfill behind the sheet piling. This structure is still in place although it has failed in many locations as shown in [Figure 11.12](#). The stone was clearly too small for the strong flow in this part of the river, and its removal has allowed the sheet pile to fail. It is also important to note that the sheet pile structure was placed without any tiebacks. The typical unfailed condition looks as shown in the [figure](#) below. The stone section was designed to extend approximately 30 ft from the sheet pile. In the critical areas where the sheet pile wall is failing or has failed, TxDOT has added H-piles to stabilize the section. It is not clear if this is the long-term solution for the site. While this construction was under contract, the state also added 2820 cubic yards of riprap to the east abutment and 1500 cubic yards to the west abutment. The riprap consisted of 18-inch stone similar to that shown in [Figure 11.15](#).



Figure 11.15. Riprap as a Countermeasure.

11.3.5 Soil Type

The soil conditions at the site consist of sandy, silty, clayey material in the surface layers and more clayey, silty, sandy material in the vicinity of the riverbed based upon [TxDOT \(1998\)](#).

11.4 STREAMBED DEGRADATION OF THE NORTH SULFUR RIVER

We wish to thank Mrs. Kathy Dyer for taking the time to show us around the bridge sites in the Paris district and for sharing with us her opinion and the data from the TxDOT files.

11.4.1 The North Sulfur River

The North Sulfur River originates near Bailey, Texas, north of Dallas. After about 80 km. (50 mi) it merges with the South Sulfur River to become the Sulfur River. After another 90 km (56 mi) the Sulfur River comes to Lake Wright Patman, then goes on for another 32 km (20 mi) to meet the Red River. Within the area of interest, the North Sulfur River has a 25 year mean discharge of approximately 20,000 cfs and a mean drainage area of approximately 100 square miles.

11.4.2 History of the Problem

Before 1920 the river was a lazy river with a relatively shallow slope, numerous meanders, and a large flood plain. This created repeated floods in farm lands and inconvenienced the farmers. In order to avoid the flooding events, it was decided in the mid-twenties to straighten and deepen the river. This straightening led to increased slope, and therefore increased velocity and severe degradation and widening of the initial channel. This degradation and widening process has been taking place over the last 70 years and seems to be slowing down. The combination of streambed degradation and channel widening has led to vertical soil erosion of up to 25 ft for some of the bridge piers (Figure 11.16) and to abutment erosion (Figure 11.17). Many creeks lead to the North Sulfur River. All these creeks have also degraded their beds to a similar extent. Several sites were visited and are described in the following summary.

11.4.3 Sites Visited

1. North Sulfur River at FM 904

This structure is an 8-40 ft span (concrete slab and girder) bridge on 24 in diameter 23 ft long drilled shafts (Figure 11.18) (Kathy, unknown on 1997 profile but shown on 1963 profile?). It was built in 1963, and at that time the bottom of the river was 90 ft wide. In 1985, the bottom of the river had become 150 ft wide with most of the widening taking place on the south side. On the south side (at pier 2), the ground level had been eroded vertically 27 ft from 1963 to 1985. During the same period, the center of the bottom of the river had been lowered by 7 ft. The soil at the south abutment is clay. The erosion seems to have slowed down when it reached the clay shale which underlies the clay layer. A river bottom profile is available in 1963 and in 1985. (Kathy, the profile in 1997/1999 does not seem to correspond to the other profiles).



Figure 11.16. Exposed Piers on the North Sulfur River.



Figure 11.17. Erosion of Abutment on the North Sulfur River.

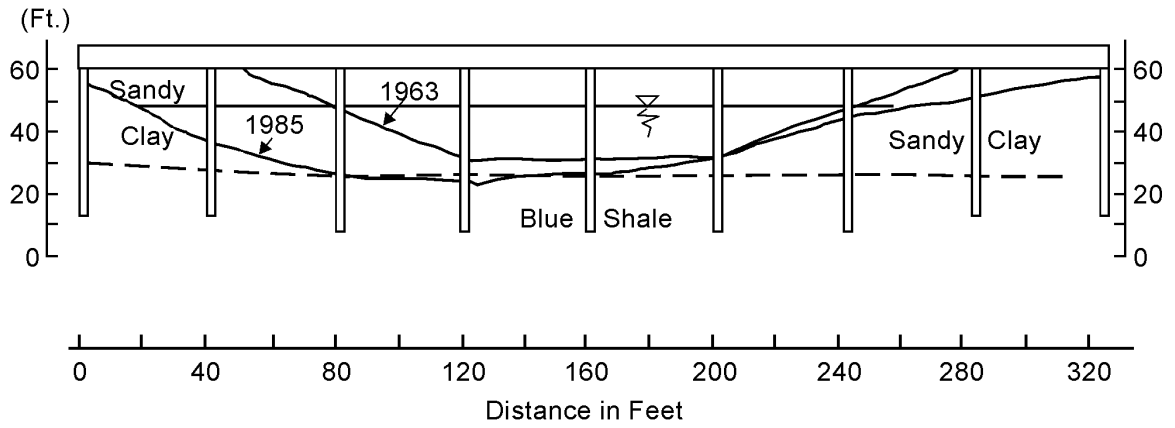
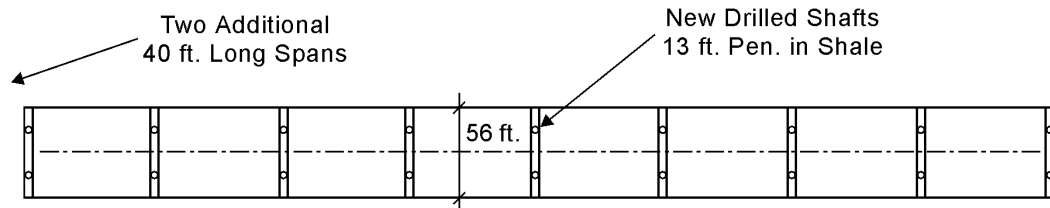


Figure 11.18. FM 904 at North Sulfur River Bridge.

2. North Sulfur River at FM 2990

This structure was built in 1967 as a 5-40 ft span (concrete slab and girder) bridge on 30 in diameter 20 ft long drilled shafts (Figure 11.19). Two 40 ft spans were added in 1985 as the river was widening significantly. Degradation of the bottom of the river is of the order of 10 ft, and the river has widened its banks by about 100 ft. The soil is clay underlain by clay shale. It appears that the river chose to widen its banks more so than degrade its streambed because the banks are made of softer soil (clay) than the streambed (clay shale). A river bottom profile is available for 1967, 1985, and 1999.

3. North Sulfur River at SH 34

This structure was built in 1959. It is an 8-40 ft span (concrete slab and girder) bridge on 30 in diameter 19 ft long drilled shafts (Figure 11.20). Degradation of the river bottom is a little over 10 ft and occurred over a period of 40 years. The channel has been widened by about 60 ft. The soil at the site is clay with some gravel on the banks and blue clay shale at the river bottom.

4. Other sites

Other sites visited or for which data was received included Davis creek at FM 2990, Davis Creek at FM 1550, Wafer Creek at FM 824, Snow Creek at FM 824, and Ghost Creek at FM 824. These sites are bridges on creeks leading to the Sulfur River where similar degradation and widening problems exist.

11.4.4 Erosion of Clay Shale

The following comments are based on observations at those bridge sites. The clay shale, which forms the bed of the Sulfur River in many places, has a very high shear strength. The undrained shear strength of this material is likely over 8000 psf. This high shear strength places this earth material at the boundary between soil and rock. Yet it is being eroded by a water flow generating shear stresses at the water soil interface which are probably of the order of 2 to 4 psf. The reason is as follows. In its wet state, the shale is very strong. When the summer comes, the beds of the creeks and of the Sulfur River become dry. The shale cracks as it shrinks under the sun, and the surface of the shale looks like an alligator skin (Figure 11.21). The cracks are about two inches apart. At the end of the summer, when the first flood comes through, there is a layer a few inches deep which resembles more a loose assemblage of gravel than a clay shale. This layer of gravel-like clay shale is removed relatively easily at the first major flood. This seasonal cycle creates an erosion rate which, while slow, is not negligible.

11.4.5 Countermeasures

Various countermeasures have been used. They range from widening the bridge, buttressing the abutments, grouting the embankment, placing gabions, and using concrete surfacing. **Widening of the bridge** is done by adding spans behind the current abutment. This extension of the bridge is easier than the original construction in that it can be done with full support of the soil at the bridge level. Once the additional spans are in place, the river is allowed to erode the existing

abutment and reach its equilibrium. In some cases one more span is not sufficient for the river to reach its equilibrium. **Buttressing the abutments** is done by stacking guard rails one on top of the other as a vertical barrier and holding the guard rail wall with short sections of driven H piles (Figure 11.22). **Grouting the embankment** is used in combination with the guard rail wall to form a single hardened unit (Figure 11.23). The grouting is done by pouring cement paste over the existing slopes of the embankment and letting the cement penetrate under its own weight into the fill. **Gabions** are used to line channels in places where the erosion rate is severe. They are man-power intensive but seem to fulfill their purpose. One of the observations with gabions is that undermining and scour occur at the transitions between the gabions and the river channel (Figure 11.24). One should ensure that this transition is not abrupt but rather a smooth and flexible one. **Concrete surfacing** of the riverbed up-stream and down-stream of bridges or culverts was used in some instances. This countermeasure seemed to work at the bridges but suffered from the same problem as the gabions: edge scour and undermining. Interestingly no riprap was encountered as a countermeasure.

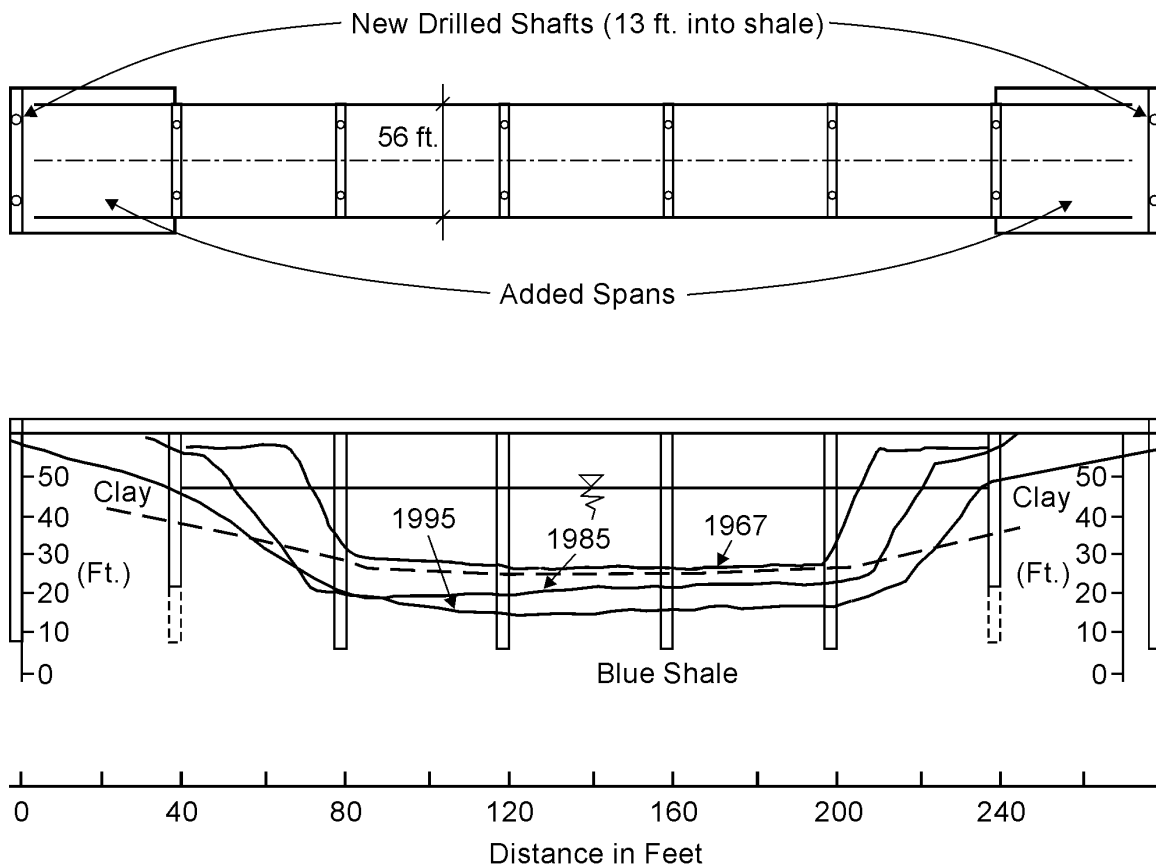


Figure 11.19. FM 2990 at North Sulfur River Bridge.

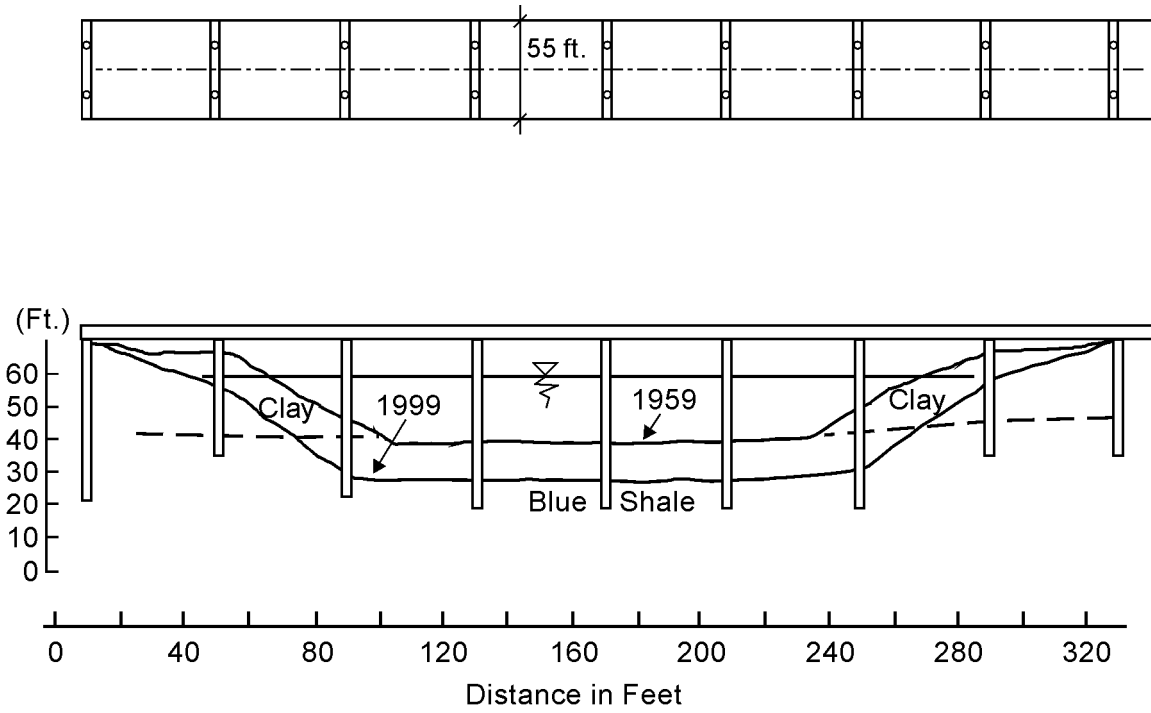


Figure 11.20. SH 34 at North Sulfur River Bridge.



Figure 11.21. Erosion of Clay Shale.



Figure 11.22. Guardrail Wall for Abutment Protection.



Figure 11.23. Guardrail Wall and Grouted Embankment.



Figure 11.24. Use of Gabions and Concrete Surfacing for Erosion Protection.

11.5 MEANDER MIGRATION ON THE GUADALUPE RIVER

We wish to thank Mr. Gerald Freytag of the TxDOT for taking the time to show us around the two sites described below on February 25, 2000 and for sharing with us his opinions and TxDOT data.

11.5.1 The Guadalupe River

The Guadalupe River originates near Kerrville, Texas and flows from northwest to southeast into the Gulf of Mexico. Two bridges were visited: U.S. 59 at Guadalupe River and SH 80 at Guadalupe River. At the U.S. 59 site, the Guadalupe River has a drainage area of approximately 5200 square miles, a 10-year discharge of 48,000 cfs, a 50-year discharge of 99,000 cfs, a 100-year discharge of 129,000 cfs, and a 500-year discharge of 219,000 cfs. These data are actually obtained at the confluence of the Guadalupe River and of Coletto Creek. The best gauge for that site appears to be gauge no. 08176500 which has a record from 1934 to present. At the SH 80 site, the Guadalupe River has a drainage area of 750 square miles, a 10-year discharge of 29,000 cfs, a 50-year discharge of 65,000 cfs, a 100-year discharge of 86,000 cfs, and a 500-year discharge of 154,000 cfs. These data are actually obtained at the H-5 dam (Wood Lake).

11.5.2 The U.S. 59 at Guadalupe River Bridge

The Bridge

The bridge is made of two structures, one north bound and one south bound, and was built in 1967 ([Figure 11.25](#)). It is a 3 continuous span steel plate girder bridge founded on 30 ft long H piles (12BP53). The center span is 150 ft long, the others are 110 ft long. The soil at the site is listed as a mixture of clay, silt, and sand. There is no rock apparent on the plans.

The Problem

At the time of construction (1967), the main axis of the river was 9 degrees of perpendicular and the main piers were aligned with the flow. At the time of the visit this angle was estimated to be about 45 degrees. The change is due to a meander which has migrated upstream of the bridge. The rate of migration was 8 ft between June 1997 and July 1998. In 1967, when the bridge was built, the river bank was 90 ft from the toe of the north abutment of the south bound bridge. In 1997 this distance was 65 ft, and in 1999 it was 20 ft ([Figure 11.26](#)). The lateral migration of the meander uncovered about 20 ft of the center pier closest to the eroding bank. The soil from the bank was observed falling in chunks because it was dried up and cracked. The drastic acceleration of the erosion rate between 1997 and 1999 made the situation an emergency.

The Proposed Solution

Several countermeasures were considered. Riprap was not retained because it would require to be placed beyond the right of way. Fences protruding into the river were not retained because it was considered to be too slow a solution. Adding spans was retained. Even though it was the most expensive solution, it was approved because the situation was considered to be an emergency. The cost of the additional spans is estimated at 2.2 million dollars.

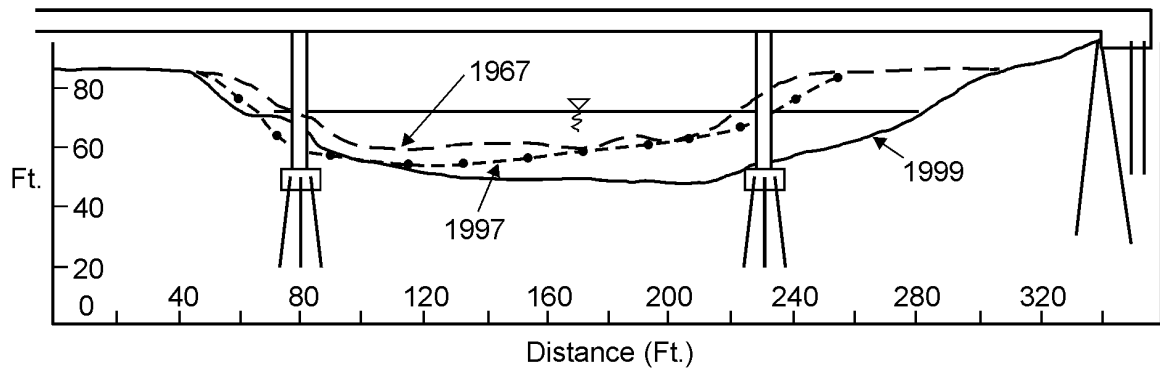
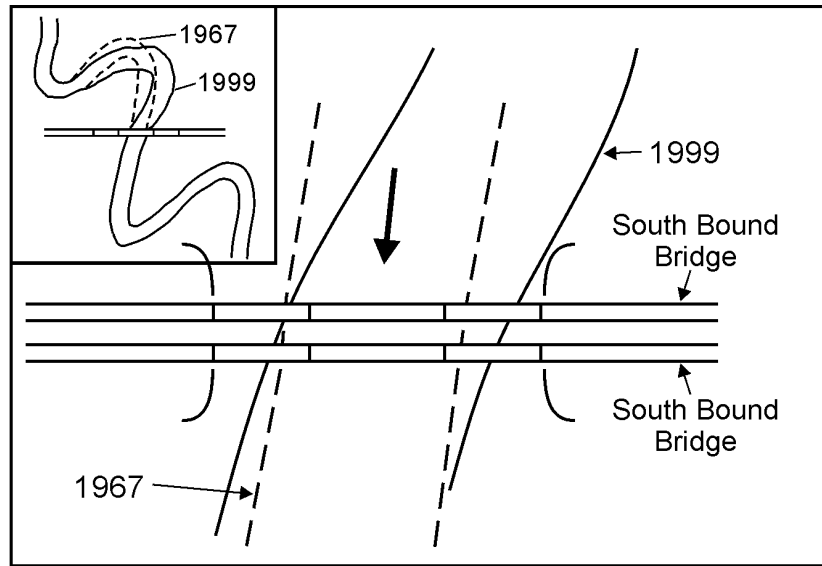


Figure 11.25. U.S. 59 at Guadalupe River Bridge (South Bound).



Figure 11.26. Bank Erosion near U.S. 59 at Guadalupe River Bridge.

11.5.3 The SH 80 at Guadalupe River Bridge

The Bridge

The bridge has 18 spans: 4 main spans, and 14 approach spans (Figure 11.27). The main spans bridge over the main channel, while ten spans on one side and four on the other side bridge over the flood plain. The main spans are continuous plate girder units about 130 ft long. The approach spans are 48 ft concrete girder spans. The bridge was built in 1953. The foundation is made of 16 inch square 24 ft long precast concrete piles. The soil is a silty sand with some gravel. The gravel content and density increase with depth.

The Problem

At the time of construction (1953) the main channel was bridged by the main span and was in a slight curvature meander. In 1993 the main channel had migrated 75 ft to the west/south-west towards the west abutment (Figure 11.28). The channel had also deepened by 10 ft. The combination of the two movements exposed 16 ft of one of the center piers which is now in the middle of the new channel.

The Solution

This meander migration problem was not considered to be an emergency. Therefore a solution less expensive than adding a span could be used. The solution which was retained was to use Ercon nets (Figure 11.29 and 11.30) (Similar to Erconet Palisades 11.3.4 Countermeasures). The first step in the construction of the nets is to drive 10 in diameter pipe piles in a series of lines protruding into the river flow. These lines of piles are oriented in a downstream direction and protrude about 50 ft into main channel which is about 100 ft wide. The top of the piles is about 20 ft above the river bed. A cable is strung across the tops of the piles in one line. Hanging from the cable are meshes made of the same material used for seat belts in cars. Six lines of these meshes were placed upstream of the pier over 200 ft of river length and one downstream. The meshes were installed in 1995 and in 1999 the situation seemed to have reversed itself slightly. The cost of the nets was 122,000 dollars. One observation was that it is important for the pile closest to the bank to be actually driven into the flood plain material so that no gap exists between the finished mesh and the bank.

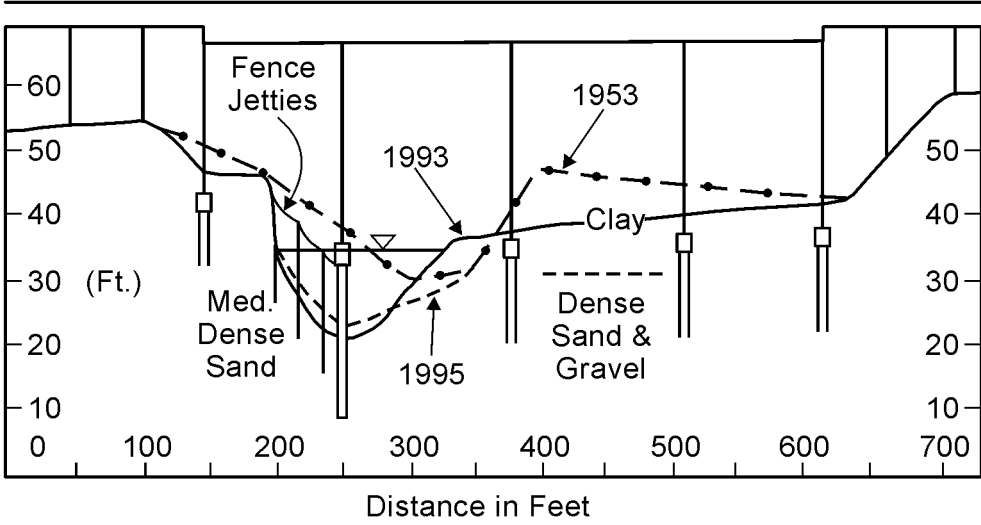
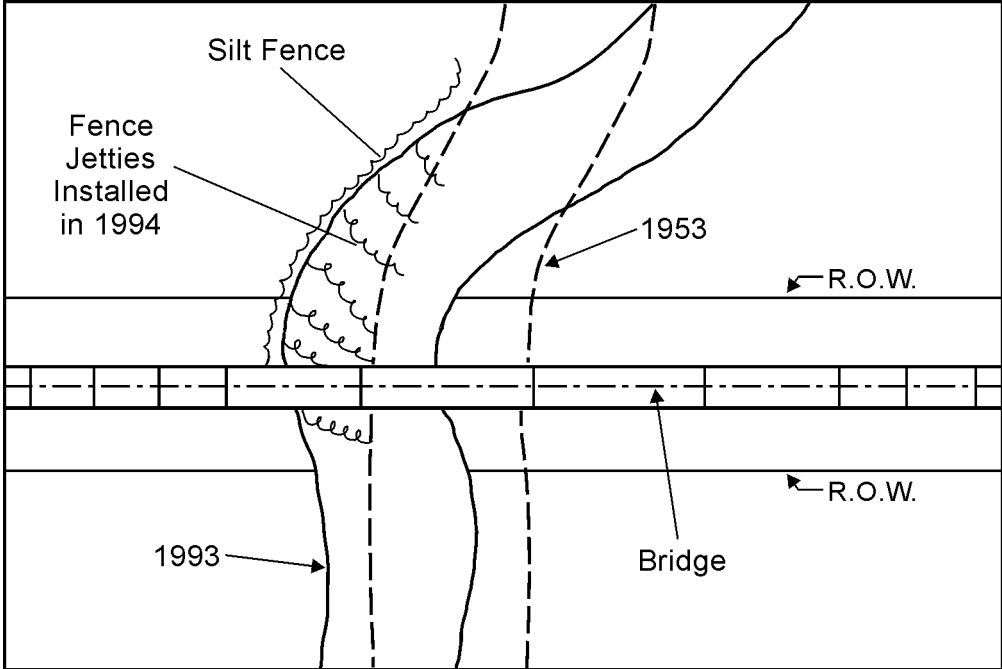


Figure 11.27. SH 80 at Guadalupe River Bridge.



Figure 11.28. Channel Migration at SH 80 at Guadalupe River Bridge.



Figure 11.29. Bank of Meander before Installation of Ercon Nets.



Figure 11.30. Bank of Meander after Installation of Ercon Nets.

12. CONCLUSIONS AND RECOMMENDATIONS FOR FURTHER RESEARCH

12.1 CONCLUSIONS

Prediction of meander migration and stream bed degradation

Two major conclusions can be drawn from the review of existing knowledge:

1. There is no reliable formula to predict these erosion movements.
2. The best existing way to predict such erosion movements is by extrapolation of historical data.

Many formulas have been developed for predicting these erosion movements. The common approach is to develop a database of observed data, to tabulate the movements or rates of movement along with various influencing parameters, and to use multiple regression techniques to arrive at a best fit equation. The limitation of these equations is two fold. First, they are limited by the extent of the database used to develop them; using them much beyond the limits of the database from which they were derived is risky. Second, they do not include some of the most important parameters affecting the problem, namely the parameters describing the soil resistance to erosion. This is not necessarily because the investigators do not recognize their importance but simply because these parameters have not been collected in the databases.

The best and most reliable current technique to predict erosion movements is by extrapolating historical data. For meander migration, it is done by using measurements taken from aerial photographs, while for streambed degradation use is made of riverbed elevations as a function of time. The significant limitation of this analysis is two fold. First, it assumes that the future hydrograph will be the same as the past hydrograph and does not allow researchers to consider a 100 year storm or a 500 year storm if one has not occurred in the past. Second, it assumes that the soil conditions to be encountered as movement progresses are the same as those where movement has already taken place.

Both databases and aerial photographs are very valuable; however, their use will be described in conjunction with the proposed approach in the recommendation section.

Countermeasures

Three main conclusions can be drawn from the review of existing knowledge:

1. There are a large number of countermeasures to choose from.
2. There is no scientific basis for choosing the right countermeasure for a given case.
3. The best current practice is based on local experience and trial and error approach.

The number of countermeasures that exists is very large. One could argue that the reason for this is that none of them are universal and that choosing the right countermeasure is a complex and site-specific problem. The closest thing to a universal countermeasure is riprap, be it made of rock or concrete blocks. There is no scientific basis for the choice of one countermeasure over

another due partly to the difficulties in modeling the problem. There are tables that give guidance as to what countermeasure is likely to work in various situations. The best current approach is based on local experience. Each district or state has gathered experience with various countermeasures and has learned from past successes and failures.

Economic risk analysis

In order to make the best decision possible in mitigating a meander migration or streambed degradation problem, an economic risk analysis can be used. Such an analysis consists of considering a number of alternative solutions and choosing the solution that leads to the best combination of low cost and high probability of success. An economic risk analysis requires that the cost of various alternatives be evaluated with reasonable accuracy and that the probability distribution for the success of each alternative be obtained. Gathering cost data is a relatively simple task. However, obtaining the probability of success for each alternative is a very difficult task considering the large number of countermeasures and the lack of scientific basis for the prediction of erosion movement and the selection of countermeasures.

Case histories

The visits to the TxDOT sites where meander migration and streambed degradation is a problem were very informative and have helped the research team get a better appreciation for the problem. Several phenomena were observed, including the erosion of very hard clay shale by desiccation cracking during dry bed conditions and later its removal by floodwaters. It was also observed that when a river degrades its bed, it also widens its channel, and if the bank is more erodible than the bed, there is more channel widening than streambed degradation. The apparently erratic nature of meander migration was also observed where a river may have been eroding its banks relatively slowly for 40 years followed by a sudden and drastic increase in erosion rate. The countermeasures at the sites were riprap, gabions, fences, and additional bridge spans. One of the major constraints for TxDOT in choosing a solution to these erosion problems is that TxDOT has limited land right of way and the state has jurisdiction only over waterways that are considered to be navigable based on State Code.

12.2 RECOMMENDATIONS FOR FUTURE RESEARCH

Prediction of meander migration and streambed degradation

As pointed out in the previous section, many attempts have been made at developing empirical equations to predict meander migration and streambed degradation. The number of equations that exist and the fact that none are used widely may be an indication that none are very reliable. Since that avenue has been extensively explored and since minimal success has come of it, we would like to propose a different approach. This new approach will be fundamentally based rather than empirically based.

We believe that the shear stress at the interface between the water and the soil is a key parameter in the erosion process. The water applies a shear stress on the soil. If this shear stress is larger

than the shear stress required to initiate erosion (critical shear stress), then erosion proceeds at a rate that is related to the shear stress applied. The relationship between shear stress and erosion rate is a soil property that can easily be measured on a site-specific basis by taking soil samples at the bridge site and testing them in the EFA, a TxDOT sponsored apparatus. The applied shear stress can be obtained from equations derived from the results of numerical simulations. The prediction of erosion movement can then proceed in time steps to follow any hydrograph. This is a fundamental approach which can be applied to any erosion process, be it pier scour, abutment scour, meander migration, or streambed degradation. This approach has been successfully used for pier scour in a recently completed TxDOT project which is being implemented.

We propose to use this approach to solve the problem of predicting meander migration and streambed degradation. Numerical simulations will be performed to simulate the water flow in a meandering channel with an erodible soil bottom. The results will lead to equations to evaluate the shear stress applied by the water on the soil for various flood velocities. The results will also give some insight on the flow patterns in meanders and on the channel widening versus bed degradation process for channel straightening. High quality model scale tests and parallel erosion soil tests in the EFA will be performed to get experimental evidence under controlled conditions. Case histories are better than model scale tests from the point of view of scale and of realistic soil conditions; however, the number of variables is much higher than in controlled laboratory experiments. These laboratory experiments play an important role in isolating the influence of various parameters. Researchers will select and study case histories in detail. Soil samples will be collected at each site and tested for erodibility in the EFA. The case histories will be used to evaluate the numerical simulations and laboratory experimental results. A site specific approach will be assembled by taking advantage of all the elements of the study. It is envisioned that the final product will be similar to the one for TxDOT pier scour study.

Countermeasures

There are numerous countermeasures. The countermeasures most commonly used by TxDOT appear to be riprap, gabions, jetty fences, and bridge span additions. Part of this research project is intended to evaluate and make recommendations on which countermeasure is most likely to work in a given situation. Two approaches are possible. The first one consists of reviewing many case histories (mostly in Texas), studying their behavior, tabulating the reasons for their success or failure, and developing a rating chart. This will lead to a qualitative recommendation on countermeasures. The success of this approach is limited by the extent of the database which can be accumulated and the quality and the details of the data. The second approach consists of simulating various countermeasures and understanding why they work or do not work in given situations. The success of this approach is limited by the number of existing countermeasures, and therefore by the very large number of simulation runs that would have to be performed.

As a start, we propose that the two most common types of countermeasures in Texas be selected and studied. We wish to discuss with the Project Monitoring Committee, which two countermeasures should be selected. It appears that riprap and jetty fences are good candidates. Once these two countermeasures are selected, the approach taken for the prediction task above can be applied to the countermeasures task. Numerical simulations are run first to understand the fundamental behavior. Model scale tests and erosion soil tests are performed to obtain a ground

truth under controlled conditions. Finally, case histories are used to verify and adjust the new method.

NCHRP research project 24-16

There is an ongoing NCHRP research project entitled “Methodology for Predicting Meander Migration.” This project is being conducted by Ayres Associates, Fort Collins, Colorado. We are in close contact with the research team of this NCHRP project and appreciate the open cooperation with our TxDOT project. There are two major differences between the TxDOT project and the NCHRP project: content and approach. The content of the TxDOT project is much broader than the NCHRP project. Indeed the TxDOT project addresses 5 distinct problems: predicting meander migration, predicting streambed degradation, countermeasures for meander migration, countermeasures for streambed degradation, and economic risk analysis. The NCHRP project addresses only one of the five problems: predicting meander migration. The approach for the prediction of meander migration in the NCHRP project is, to our understanding, a database approach aiming at an empirical formulation. The proposed approach in the TxDOT project is a mix of numerical simulation, flume scale testing, and soil testing to identify and understand the basic phenomenon with the goal of developing a fundamentally correct yet simple solution to be verified by comparison against quality case histories. We have benefited from our interaction with the research team at Ayres and Associates and wish to thank them for sharing their knowledge.

Cost and duration

As pointed out earlier, the problem is a serious one. It endangers the public safety, and the current solutions are inadequate. The problem is also a sizeable one with many interconnected topics. A serious and long lasting solution will require a major commitment from TxDOT. In order to arrive at such a serious and long lasting solution, the project must be a major effort and cannot be done in one year.

The NCHRP study is a \$300,000 study, and it addresses one-fifth of the TxDOT project. A simple extrapolation would put the TxDOT project at \$1,500,000. Note that even though this number seems large it is only a fraction of the cost of one single bridge span extension project, let alone of the amount of money spent on countermeasures in Texas in general. The previous TxDOT study on pier scour led, in our opinion, to a serious and long lasting solution. This project is getting to be known worldwide as a significant contribution in the advancement of scour knowledge and scour solutions. This major project lasted four years and cost about \$600,000. We envision that the proposed project which is larger in scope than the previous one but which benefits from the acquired knowledge at Texas Transportation Institute/Texas A&M University, would be an eight-to-ten year project with a budget of \$130,000 per year.

12.3 ACTION PLAN

In order to provide a reasonable solution to this major TxDOT problem, the following projects are proposed as a general action plan.

- Project 1. Soil Properties Based Prediction of Meander Migration Rate.
(years 1, 2, and 3) (estimated budget \$120,000/year)
- Project 2. Countermeasures to Protect Bridges and Highways against Meander Migration.
(years 4, 5, and 6) (estimated budget \$120,000/year)
- Project 3. Prediction of Streambed Vertical Degradation and Countermeasures.
(years 7, 8, and 9) (Estimated budget \$120,000/year)

The first project (Soil Properties Based Prediction of Meander Migration Rate) is detailed here.

Task 1. Flume Tests

Perform flume tests to simulate the behavior of meanders under controlled conditions. Vary essential parameters including soil type, flow rate, and meander configuration. Measure soil properties, flow rate, and change of meander geometry as a function of time.

Task 2. Erosion Tests

Perform erosion tests on the soils used in task 1. These tests should lead to the erosion function which describes the influence of velocity on erosion rate.

Task 3. Numerical Simulation

Use a computer program to simulate the meander migration process. Perform a parametric analysis including different soil erosion rates, different flow rates, and different channel configurations. Validate the computer model with the flume test results.

Task 4. Develop Prediction Procedure

Use the results of tasks 1, 2, and 3 to develop a simple prediction procedure for meander migration including site specific soil properties.

Task 5. Verification

Select a number of case histories to verify the procedure proposed in task 4. Visit the sites, collect soil samples, collect necessary hydraulic information, and collect information on migration rate. Test the soil samples, apply the prediction procedure, and compare predicted and measured behavior. Modify the proposed procedure if necessary.

Task 6. Report

Write a summary report to be used as guidelines for predicting meander migration rate.

13. REFERENCES

- Abam, T. K. S., Okagbue, C. O., 1986, Construction and Performance of River Bank Erosion Protection Structure in the Niger Delta,” Bulletin of the Association of Engineering Geologists Vol. 23, no. 4, pp. 499-506.
- Abam, T. K. S., 1993, “Control of Channel Bank Erosion Using Permeable Groins,” Environmental Geology, Vol. 22, no. 1, pp. 21-25.
- Bagnold, R. A., 1966, “An Approach to the Sediment Transport Problem from General Physics,” U.S. Geological Survey Prof. Paper 422-I, pp.1-37.
- Begin, Z. B., 1981, “Stream Curvature and Bank Erosion: A Model Based on the Momentum Equation,” Journal of Geology, Vol. 89, pp. 497-504.
- Begin, Z. B., 1986, “Curvature Ratio and Ratio of River Bend Migration Update,” Journal of Hydraulic Engineering, Vol. 112, no. 10, pp. 904-908.
- Blench, T., 1969, “Mobile-Bed Fluviology,” University of Alberta Press, Edmonton, Canada.
- Bradely, J. N., 1978, “Hydraulics of Bridge Waterways,” Hydraulic Design Series No. 1, U.S. Department of Transportation, FHWA.
- Brice, J. C., 1971, “Measurement of Lateral Erosion at Proposed River Crossing Sites of the Alaska Pipeline,” United States Department of the Interior, Geological Survey, Water Resources Division, Alaska District.
- Brice, J. C., 1975, “Airphoto Interpretation of the Form and Behavior of Alluvial Rivers,” Final Report to the U.S. Army Research Office.
- Brice, J.C., 1982, “Stream Channel Stability Assessment,” Federal Highway Administration Report, FHWA/RD-82/021, p. 41.
- Brice, J. C., 1984, “Assessment of Channel Stability at Bridge Sites,” Transportation Research Record, pp. 163-171.
- Brice, J. C., Blodgett, J. C., 1978, “Countermeasures for Hydraulic Problems at Bridges, Vol. I. Analysis and Assessment. (Final report. Jun 75 – Sep 78),” Geological Survey, report no. FHWA/RD-78/162, p.187.
- Brown, S. A., Mcquivey, R. S., Keefer, T. N., March 1981, “Stream Channel Degradation and Aggradation: Analysis of Impacts to Highway Crossings,” FHWA, report no. FHWA-RD-80-159.
- Brown, S. A., 1982, “Prediction of Channel Bed Grade Changes at Highway Stream Crossings,” Transportation Research Record, pp. 1-7.

- Brown, S. A., 1985, "Design of Spur Type Streambank Stabilization Structures, Final Report," FHWA/RD-84-101, Federal Highway Administration, Washington, D.C.
- Brown, S. A., 1985, "Streambank Stabilization Measures for Highway Engineers," FHWA/RD-84.100, Federal Highway Administration, McLean, Virginia.
- Brown, S. A., 1985, "Streambank Stabilization Measures for Highway Stream Crossings Executive Summary," FHWA/RD-84/099, Federal Highway Administration, Washington, D.C.
- Causey, W. R., 1966, "Bank Stabilization, Red River Below Denison Dam," Symposium on Channel Stabilization Problems: U.S. Waterways Experiment Station, Vicksburg, Mississippi, Committee on Channel Stabilization Technical Report No. 1, Vol. 4, Chapter IV.
- Chang, H. H., 1984, "Analysis of River Meanders," Journal of Hydraulic Engineering, ASCE, Vol. 110, no. 1, pp. 37-50.
- Chang, T. P., Toebes, G. H., 1980, "Geometric Parameters for Alluvial Rivers Related to Regional Geology," Proceedings-International Association for Hydraulic Research Congress, (14, Vol. 3), pp. 192-201.
- Chitale, S. V., 1980, "Shape and Mobility of River Meanders," Proceedings, Subject A, XIX, IAHR Congress 19, Vol. 2, pp. 281-286.
- Clifton, A. W., Krahn, J., Fredlund, D. G., 1981, "Riverbank Instability and Development Control in Saskatoon," Can Geotech J., pp. 95-105.
- Comes, B. M., 1990, "Identification Techniques for Bank Erosion and Failure Processes," in Hydraulic Engineering; Proceedings of the 1990 National Convention, Chang, H. H. (ed.), pp. 193-197.
- Diehl, T. H. and Bryan, B. A., 1993, "Supply of Large Woody Debris in a Stream Channel," in Hydraulic Engineering, Proceedings of the 1993 National Conference on Hydraulic Engineering, Shen, H. W., Su, S. T., Wen, F., (eds), ASCE, New York, pp. 1055-1060.
- Franco, J. J., 1967, "Effects of Stages on Scour along Riverbanks, Paper A29," in IAHR, 12th Cong, pp. 232-239.
- Gilje, S. A., March 1979, "Debris Problems in the River Environment," Public Roads, Vol. 42, no. 4, pp. 136-141.
- Gilje, S. A., 1982, "Stream Channel Grade Change and Their Effects on Highway Stream Crossings," Transportation Research Report, pp. 7-10.
- Gregory, K. J., 1977, *River Channel Changes*, John Wiley & Sons, New York, p. 448.
- Hagerty, D. J., Hamel, J. V., 1989, "Geotechnical Aspects of River Bank Erosion," in Proceedings of the 1989 National Conference on Hydraulic Engineering, pp.118-123.

Haimes, Yacov Y., 1998. *“Risk Modeling, Assessment, and Management,”* John Wiley & Sons, New York. p. 726.

Hanson, G. J., Lohnes, R. A., and Klaiber, F. W., 1986, “Gabions used in Stream-Grade-Stabilization Structures: A Case History,” *Transportation Research Record*, pp. 35-42.

Harvey, M. D., 1989, “Meanderbelt Dynamics of the Sacramento River, California”: in Abell, D. L. (ed.) *Pro. Calif. Riparian Systems Conf.*, Forest Service, Pacific Southwest Forest and Range Experiment Station Gen. Tech. Report, PWS-110, pp. 54-59.

Hasegawa, K., 1989, “Universal Bank Erosion Coefficient for Meandering Rivers,” *Journal of Hydraulic Engineering*, Vol. 115, no.6, pp. 744-765.

Herr, L. A., 1970, “The Control of Erosion and Sediment in Highway Construction,” *Proceedings of National Conference on Sediment Control*, Sep 14-16, 1969, Washington D.C., Environmental Planning paper, Department of housing and urban development, pp. 41-47, May 1970. p. 7.

Hickin, E. J., 1974, “Development of Meanders in Natural River Channels,” *American Journal of Science*, Vol. 274, pp. 414-442.

Hickin, E. J., 1977, “The Analysis of River-Planform Responses to Change in Discharge, River Channel Changes,” pp. 249-263.

Hickin, E. J., Nanson, G. C., 1975, “The Character of Channel Migration on the Beatton River,” *Northeast British Columbia, Canada: Geol. Soc. America, Bull*, Vol. 86, pp. 487-494.

Hickin, E. J., Nanson, G. C., 1984, “Lateral Migration Rates of River Bends,” *Journal of Hydraulic Engineering*, Vol.110, no.11, pp. 1557-1567.

Holly, F. M., Jr., Nakato, T., Kennedy, J. F., 1984, “Computer-Based Prediction of Alluvial Riverbed Changes,” *Transportation Research Record* 950, pp. 229-237.

Hooke, J. M., 1980, “Magnitude and Distribution of Rates of River Bank Erosion,” *Earth Surface Processes*, Vol. 5, no. 2, pp. 143-157.

Hudson, H. R., 1982, “A Field Technique to Directly Measure River Bank Erosion,” *Canadian Journal of Earth Sciences*, 19, 2, pp. 381-383.

Ikeda, S., Parker, G., and Sawai, K., 1981, “Bend Theory of River Meanders, 1, Linear Development,” *Journal of Fluid Mechanics*, Vol.112, pp.363-377.

Indian Roads Congress, 1966, “Standards Specifications and Code of Practice for Bridges,” India.

Inglis, Sir C., 1947, "Meanders and their bearing on River Training," Maritime and Waterways Paper no. 7, Institution of Civil Engineering, London.

Jain, S. C., Park, I., 1989, "Guide for Estimating Riverbed Degradation," Journal of Hydraulic Engineering, Vol. 115, no. 3, pp. 356-366.

Johnson, P.A., Simon, A., 1995, "Reliability of Bridge Foundations in Unstable Alluvial Channels," Proceeding, First International Conference on Water Resources Engineering, ASCE, San Antonio, TX, U.S.A., August, pp. 1041-1045.

Johnson-Payton, L. 1997, "The Impact of Multiple Failure Modes in Risk Analysis for Civil Infrastructure Management," Ph.D. dissertation, University of Virginia, Charlottesville.

Johnson, P. A., Gleason, G. L., Hey R. D., 1999, "Rapid Assessment of Channel Stability in Vicinity of Road Crossing," ASCE Journal of Hydraulic Engineering, Vol. 125, no.6, pp. 645-651.

Jones, J. E., 1977, "Calculation of Evapotranspiration Using Color-Infrared Photography," Gila River Phreatophyte Project, U.S. Geological Survey.

Keady, D. M., Priest, M. S., 1977, "The Downstream Migration Rate of River Meandering Patterns," Proceedings, Mississippi Water Resources Conference, Meeting 12th Mississippi Water Resources Conference, Jackson, MS, pp. 29-34.

Keefer, T. N., Mcquivey, R. S., Simons, D. B., 1980, "Stream Channel Degradation and Aggradation: Causes and Consequences to Highways. FHWA, report no. FHWA-RD-80-038. p. 86.

Keown, M. P., 1964, "Streambank Protection Guidelines for Landowners and Local Governments," U.S. Army Corps of Engineers, Waterways Experiment Station, Vicksburg, Mississippi.

Lacey, G., 1930, "Stable Channels in Alluvium," Paper 4736, Minutes of the Proc., Institute of Civil Engineers, Vol. 229, William Clowes and Sons Ltd., London, Great Britain, pp. 259-292.

Lafayette, R. A., Pawelek, D. W., 1989, "New Revetment Design Controls Streambank Erosion," Public works Journal, pp. 54-57.

Lagasse, P. F., Schall, F. J., Richardson, E. V., Chang, F., 1995, "Stream Stability at Highway Structures," Second Edition, Report No. FHWA HI 96-032 HEC-20.

Lagasse, P. F., Byars, M. S., Zevenbergen, L. W., Clopper, P. E., 1997, "Bridge Scour And Stream Instability Countermeasure, Experience, Selection, and Design Guidance," Report No. FHWA HI-97-030 HEC-23.

Lane, E. W., 1957, "A Study of the Shape of Channels Formed by Natural Streams Flowing in Erodible Materials," M.R.D. Sediment Series No. 9, U.S. Army Engineers Division, Missouri River Corps of Engineers, Omaha, NE. U.S.A.

Langbein, W. B., Leopold, L. B., 1966, "River Meanders – Theory of Minimum Variance," U. S. Geological Survey Professional Paper 422-H.

Leopold, L. B., Maddock, T. Jr., 1953, "The Hydraulic Geometry of Stream Channels and Some Physiographic Implications," U. S. Geological Survey Professional Paper 252, U. S. Department of the Interior, United States Government Printing Office, Washington D. C., U. S.A.

Leopold, L. B., Wolman, M. G., 1957, "River Channel Patterns - Braided, Meandering, and Straight," U. S. Geological Survey Professional Paper 282-B, pp. 39-85.

Leopold, L. B., Wolman, M. G., 1960, "River Meanders," U. S. Geological Society American Bulletin Vol. 71.

Levent, V., 1991, "Meander Bend Expansion and Meander Amplitude Development," Proceedings of the Fifth Federal Interagency Sedimentation Conference, 5, pp. 3.118-3.125.

Lowrance, W. W., 1976, "*of Acceptable Risk*, William Kaufman, Los Altos, C.A.

Ligeng, L., Schiara, M., 1989, "Meander Bend Expansion and Meander Amplitude Development," Theoretical models, Proceedings of the Fourth International Symposium on River Sedimentation, pp. 857-864.

Melville, B. W., Coleman, S. E., 1999, "Bridge Scour," Water Resources Publications, LLC, Highlands Ranch, CO, U.S.A., p. 551.

Meyer, L. D., Peter, E., and Muller, R., 1948, "Formulas for Bed Load Transport, International Assoc. Hydr. Res., 2rd Meeting, Stockholm.

Michiue, M., Hinokidani, O., Suzuki, K., 1989, "Simulation and Countermeasure against Bed Degradation and Aggradation in River Channel," Proceedings of the Fourth International Symposium on River Sedimentation. 4; pp. 1395-1402.

Monk, W. C., 1995, "July 1993 Flood Damage to U.S.71 Bridge Over Brushy Creek, Carroll County, Iowa: Case Study," Transportation Research Record, pp. 82-91.

Mosselman, E., Crosato, A., and Hasegawa, K., 1991, "Universal Bank Erosion Coefficient for Meandering Rivers," Journal of Hydraulic Engineering, Vol. 117, no. 7, pp. 942-946.
(Discussion and Closure)

Nagabhushanaiah, H. S., 1967, "Meandering of Rivers," Bulletin of the International Association of Scientific Hydrology, Vol. 12, no. 1, pp. 28-43.

- Nanson, G. C., Hickin, E. J., 1983, "Channel Migration and Incision on the Beatton River," *Journal Hydraulic Engineering*, ASCE, Vol. 109, no. 3, pp. 327-337.
- Nanson, G. C., Hickin, E. J., 1986, "A Statistical Analysis of Bank Erosion and Channel Migration in Western Canada," *Geol. Soc. America, Bull.* Vol. 97, pp. 497-504.
- Niell, C. R., Galay, V. J., 1967, "Systematic Evaluation of River Regime," *Journal of the Waterways and Harbors Division*, ASCE, Feb., pp. 25-53.
- Neill, C.R. (Ed.) 1973, "Guide to Bridge Hydraulics," *Roads and Transportation Assoc. of Canada*, University of Toronto Press, Toronto, Canada, p. 191.
- Neill, C. R., 1984, "Bank Erosion vs. bedload Transport in a Gravel River," *Rivers 83*, in *Proceedings, American Society of Civil Engineering and International Association of Hydraulic Research Conference*, New Orleans, pp. 204-211.
- Odgaard, A. J., 1987, "Streambank Erosion Along Two Rivers in Iowa," *Water Resources Research*, Vol. 23, no. 7, pp. 1225-1236.
- Odgaard, A. J., Spoljaric, A., 1989, "Sediment Control by Submerged Vanes. Design Basis," *American Geophysical Union*, pp. 127-151.
- Odgaard, A. J., Wang, Y., 1990, "Sediment Management with Submerged Vanes," in *Hydraulic Engineering: Proceedings of the 1990 National Conference*, pp. 963-968.
- Osman, A. M., Thorne, C. R., 1988, "Riverbank Stability Analysis; I, Theory," *Journal of Hydraulic Engineering*, Vol.114, no. 2, pp. 134-150.
- Osman, A. M., Thorne, C. R., 1988, "Riverbank Stability Analysis; II, Theory," *Journal of Hydraulic Engineering*, Vol.114, no. 2, pp. 151-172.
- Pagan-Ortiz, J. E., , "Stability of Rock Riprap for Protection at Toe of Abutments at Flood Plain," *Transportation Research Record 1350*, pp. 34-43.
- Peterka, A. J., 1964, "Hydraulic Design of Stilling Basins and Energy Dissipators," *Engineering Monograph No. 25*, Bureau of Reclamation, Division of Research, Denver, Colorado.
- Pfankuch, 1975, "Stream Reach Inventory and Channel Stability Evaluation," *U.S. Department of Agriculture, Forest Service, Northern Region*.
- Raiffa, H., 1964, *Decision Analysis: Introductory Lectures on Choices Under Uncertainty*, Random House, New York.
- Richard, P., George, T., 1999, "CAESAR: An Expert System for Evaluation of Scour and Stream Stability," *NCHRP, report no. 426*.

Richardson, E. V., Simons, D. B., 1984, "Use of Spurs and Guidebanks for Highway Crossings," Transportation Research Record, pp. 184-193.

Richardson, E. V., Simons, D. B., Julien, P. Y., 1990, "Highways in the River Environment," prepared for the Federal Highway Administration, Washington, D.C. by the Department of Civil Engineering, Colorado State University, Fort Collins, Colorado.

Rozovskii, I. L., 1961, "Flow of Water in Bends of Open Channels," Israel Program for Scientific Translation, Jerusalem, Israel.

Rus, David L., Soenksen, Philip J., 1998, "Channel Stability of Turkey Creek, Nebraska," International Water Resources Engineering Conference – proceedings, Vol. 2, pp. 1882-1887.

Santos-Cayado, J., 1972, "State Determination for High Discharges," Ph.D. thesis, Colorado State University, Fort Collins, Colorado, U.S.A.

Schall, J. D., Lagasse, P. E., 1991, "Stepwise Procedure for Evaluating Stream Stability," Transportation Research Record, report no. 0-309-05067-7, pp. 254-267.

Schumm, S. A., 1968, "River Adjustment to Altered Hydrologic Regime – Murrumbidgee River and Paleochannels, Australia," U. S. Geological Survey Professional Paper, p.598.

Schumm, S. A., 1971, "Fluvial Geomorphology: Channel Adjustment and River Metamorphosis," in *River Mechanics*, edited by Shen, H. W., Fort Collins, Colorado, U.S.A, pp. 5.1-5.22.

Shen, H. W., Schumm, S. A., Nelson, J. D., Doehring, D. O., Skinner, M. M., Smith, G. L., 1981, *Methods for Assessment of Stream-related Hazards of Highways and Bridges*, Colorado State University, Engineering Research Center, report no. FHWA-RD-80-160; FCP 35H1-062, pp. 252.

Shen, H. W., Wang, S. Y., 1984, "Analysis of Commonly Used Riprap Design Based on Extended Shields Diagram," Transportation Research Record 950, pp. 217-221.

Sherrill, J., Kelly, S., 1992, "Using Scour and Stream Instability Evaluations to Increase Bridge Safety," Public works, pp. 56-57.

Sidorchuk, A., Matveev, B., 1997, "Channel Processes and Erosion Rates in the Rivers of the Yamal Peninsula in Western Siberia, Variability in Stream Erosion and Sediment Transport," IAHS-AISH Publication, 224, pp. 197-202.

Simon, A., 1994, "Width Adjustment: Relative Dominance in Unstable Alluvial Streams," Proc. A.S.C.E. National Hydraulic Conference, Buffalo, New York, U.S.A., pp. 974-978.

Simon, A., 1995, "Adjustment and Recovery of Unstable Alluvial Channels: Identification and Approaches for Engineering Management," *Earth Surface Processes and Landforms*, Vol.20, pp. 611-628.

Simon, A. and Darby, S.E., 1997, "Bank Erosion Processes in Two Incised Meander Bends: Goodwin Creek, Mississippi," *Proceedings, Conference on the Management of Landscapes Disturbed by Channel Incision*, edited by S.S.Y. Wang, E.J. Langendoen and F. D. Shields, Jr., University of Mississippi, Oxford, Mississippi, U.S.A., pp. 256-261.

Small, E. P., 1999, "Examination of alternative strategies for integration of seismic risk considerations in bridge management systems," *Eighth Transportation Research Board Conference on Bridge Management*, Denver, National Academies Bookstore, pp. 19.

Soni, J. P., 1975, "Aggradation of Stream Due to Increase in Sediment Load. Ph.D. thesis, Univ. of Roorkee, Roorkee, India.

Soni, J. P., 1978, "Effect of Increase of Sediment Load on Roughness Coefficient in unsteady Flow, *International Conference on Water Resources Eng. Bangkok, Thailand*, pp. 10-13.

Soni, J. P., Sarda, V. K., 1982, "Manning's Roughness Coefficient in Degrading Alluvial Channels, *Third Congress of Asian and Pacific Region. Div. of IAHR, Bandung, Indonesia*.

Soni, J. P., Kumar, N., 1980, "Evaluation of Friction Factor in Aggrading and Degrading Alluvial Channels," in *Third International Workshop on Alluvial River Problems*, pp. 73-80.

Stevens, M. A., Simons, D. B., Richardson, E. V., 1984, "Riprap Stability Analysis," *Transportation Research Record 950*, pp. 209-216.

Suryanarayana, B., 1969, "Mechanics of Degradation and Aggradation in a Laboratory Flume. Ph.D. Dissertation, Colorado State Univ.

TxDOT, 1957, Plans of Completed Bank Protection Upstream from Trinity River Bridge, Federal Aid Project No. MC 813-1-11.

TxDOT, 1974, Plans of Completed State Highway Improvement, State Highway 105, Trinity River Bridge Repairs, Control 813-1, Replace East Span of Existing Structure.

TxDOT, 1975, Plans of Completed State Highway Improvement, Trinity River Bridge and Approaches State Highway No 105, Liberty County.

TxDOT, 1986, Plans of Completed State Highway Improvement at Trinity River Erosion Control.

TxDOT, 1995, Trinity River Bank Erosion, F.M. Hwy 787.

TxDOT, 1998, Plans of Proposed State Highway Improvement, SH 105 and FM 787, Plans for Repairing Scour Damage around Bridge Bents.

Thompson, P. L., 1990, "April 1989 Hatchie River U.S.51 Bridge Failure," Transportation Research Record, report no. 0-309-05065-0 pp. 24-35.

Thorne, C. R., 1998, *Stream Reconnaissance Handbook*, John Wiley & Sons, Chichester.

Trent, R. E., Brown, S. A., 1984, "An Overview of Factors Affecting River Stability," Transportation Research Record, pp. 156-163.

Trutman, O., Undated, "Levelling," Wild Heerbrugg Ltd., Switzerland.

Tseng, M. T., Knepp, A. J., and Schmalz, R. A., 1975, "Evaluation of Flood Risk Factors in the Design of Highway Stream Crossings", Vol. IV of Economic Risk Analysis for Design of Bridge Waterway, by Water Resources Engineers, report no. WRE-20810; FHWA-RD-75-54, p. 191.

Twidale, C. R., 1964, "Erosion Influencing Erosion of a Cohesive Bank," American Journal of Science, 257, pp. 204-216.

U.S. Army Corps of Engineers, 1981, "The Streambank Erosion Control Evaluation and Demonstration Act of 1974," Final, Report to Congress, Executive Summary and Conclusions. Washington, D.C., U.S.A.

U.S. Army Corps of Engineers, 1996, "*Risk-Based Analysis for Flood Damage Reduction Studies*," Engineer Manual 1110-2-1619, Washington, D.C., U.S.A.

U.S. Bureau of Reclamation, 1984, "Computing Degradation and Local Scour," Technical Guideline for Bureau of Reclamation, prepared by E.L. Pemberton and J.M. Lara, Jan.

Weber, L. L., 1996, "Channel Scour Protection at Roadway Crossings," North America Water and Environment Congress, ASCE, New York, U.S.A.

Williams, G. P., 1986, "River Meanders and Channel Size," Journal of Hydrology, 88(1-2), pp. 147-164.

Wolman, M. G., 1959, "Factors influencing erosion of a cohesive bank. American Journal of Science, 257, pp. 204-216.

Wolman, M. G., and Miller, J. P., 1960, "Magnitude and Frequency of Forces in Geomorphic Processes," Journal of Geology, 68, pp.54-74.

Yang, X., Mcvey, M. J., Morris, L. L., Baumel, C. P., 1995, "Impact of Stream Degradation on Bridges and Rural Travel Patterns," Transportation Research Board, pp. 82-91.

