

1. Report No. TX-95/1994-5		2. Government Accession No.		3. Recipient's Catalog No.	
4. Title and Subtitle REDUCTION OF SULFATE SWELL IN EXPANSIVE CLAY SUBGRADES IN THE DALLAS DISTRICT				5. Report Date November 1994 Revised: May 1995	
				6. Performing Organization Code	
7. Author(s) Sanet Bredenkamp and Robert L. Lytton				8. Performing organization Report No. Research Report 1994-5	
9. Performing Organization Name and Address Texas Transportation Institute The Texas A&M University System College Station, Texas 77843-3135				10. Work Unit No. (TR AIS)	
				11. Contract or Grant No. Study No. 7-1994, Task 16	
12. Sponsoring Agency Name and Address Texas Department of Transportation Research and Technology Transfer Office P. O. Box 5080 Austin, Texas 78763-5080				13. Type of Report and Period Covered Interim: September 1993 - August 1994	
				14. Sponsoring Agency Code	
15. Supplementary Notes Research performed in cooperation with the Texas Department of Transportation. Research Study Title: Highway Planning and Operation for District 18 Phase III					
16. Abstract The addition of hydrated lime to clay soils is one of the most common methods of soil stabilization. However, when sulfates are present in the soil, the calcium in the lime reacts with the sulfates to form ettringite, an expandable mineral. This expansion causes a considerable amount of economical as well as structural problems. Sulfate related heave has been experienced along IH 45 and FM 1382. In this research, a field test method was developed to locate sulfate bearing soils. A permittivity probe was used to measure the electrical conductivity of the in situ soil. The electrical conductivity was then related to sulfate content in soils. Expansion tests were performed to determine the amount of expansion that occurs when lime is added to soils with different sulfate contents. A model that relates the amount of expansion of clay soils to electrical conductivity was proposed. The use of low calcium fly-ashes were investigated and proposed as an alternative form of stabilizer for sulfate bearing soils.					
17. Key Words Sulfate Swell, Ettringites, Low Calcium Fly-Ash Stabilizers			18. Distribution Statement No restrictions. This document is available to the public through NTIS: National Technical Information Service 5285 Port Royal Road Springfield, Virginia 22161		
19. Security Classif.(of this report) Unclassified		20. Security Classif.(of this page) Unclassified		21. No. of Pages 124	22. Price

**REDUCTION OF SULFATE SWELL IN EXPANSIVE CLAY SUBGRADES
IN THE DALLAS DISTRICT**

by

Sanet Bredekamp
Research Assistant
Texas Transportation Institute

and

Robert L. Lytton
Research Engineer
Texas Transportation Institute

Research Report 1994-5
Research Study Number 7-1994, Task 16
Research Study Title: Highway Planning and Operation for District 18 Phase III

Sponsored by the
Texas Department of Transportation

November 1994
Revised: May 1995

TEXAS TRANSPORTATION INSTITUTE
The Texas A&M University System
College Station, Texas 77843-3135

IMPLEMENTATION STATEMENT

Sulfate related heave was experienced along FM 1382 and IH 45. The mechanism of the heave and a proposed solution to the problem are described in this report. A field measurement procedure to determine an estimated amount of sulfate related heave before and after lime stabilization is described. Electrical conductivity is related to sulfate content and can, therefore, be used to determine whether substantial amounts of sulfates are present and whether they will cause a problem upon lime stabilization. Three different low calcium fly-ashes were used as alternative stabilization methods for sulfate bearing soils. The fly-ashes performed well and their results are described in this report.

The field measurement procedure developed in this project is sufficiently promising to warrant pilot and subsequently full implementation by those district laboratories which must contend with sulfate swelling subgrades. A step-by-step procedure to determine sulfate related expansion in clay soils is included in the implementation section at the end of this report.

DISCLAIMER

The contents of this report reflect the views of the authors who are responsible for the facts and accuracy of the data presented herein. The contents do not necessarily reflect the official views or policies of the Texas Department of Transportation. This report does not constitute a standard, specification, or regulation.

TABLE OF CONTENTS

	Page
LIST OF FIGURES	xiii
LIST OF TABLES	xvi
SUMMARY	xix
CHAPTER 1 INTRODUCTION	1
CHAPTER 2 LITERATURE REVIEW	5
Introduction	5
Conductivity of Soils	5
Electrical Conductivity in Soils	5
Conventional Methods for Measuring Soil Electrical Conductivity	6
Relation of Conductivity to Salt Content and Osmotic Pressure	8
The Effect of Soil: Water Ratios on the Electrical Conductivity	8
The Effect of Temperature on Conductivity	8
Electrical Conductivity Measurements with Permittivity Probe	13
Mineralogy of Clay Soils	13
Stabilization of Base Courses with Lime	18
Formation of Ettringites	18
CHAPTER 3 METHODOLOGY	21
Introduction	21
Method for Determination of Expansion of Sulfate Bearing Clay Soils	22
Method for Determining Electrical Conductivity with Permittivity Probe and the EPA Method No. 9050	25

	Page
Method for Investigating Several Low Calcium Fly-Ashes as Alternative Stabilizers	28
Methods by which Supplementary Tests were Performed	28
Cation Exchange Capacity Determination	28
Method for Determination of Soluble Sulfate Content	29
Method for Determination of Dielectric Constants	29
CHAPTER 4 RESULTS FROM EXPANSION TESTS	31
Introduction	31
Results of Expansion Tests Performed on Samples from IH 45 and FM 1382	31
Results of Expansion Tests Performed on Clay Soil Samples	39
Conclusions	42
CHAPTER 5 RESULTS FROM ELECTRICAL CONDUCTIVITY MEASUREMENTS	43
Introduction	43
Results from Soluble Sulfate Determination	43
Results from Electrical Conductivity Measurements on Soil Samples Obtained from IH 45 and FM 1382	45
Results from Electrical Conductivity Measurements on Four Clay Soils	45
Water Content of the In Situ Soil	54
Conclusions	55
CHAPTER 6 RESULTS OF SUPPLEMENTARY TESTS	57
Introduction	57
Results from Cation Exchange Capacity Determination	57
Results of Dielectric Constant Measurements	59
Conclusions	63

	Page
CHAPTER 7 RESULTS OF LOW CALCIUM FLY-ASH STABILIZATION	65
Introduction	65
Results of Low Calcium Fly-Ash Stabilization on Four Clay Soils	65
Results of Low Calcium Fly-Ash Stabilization on FM 1382 Site No 7	69
Evaluation of Different Low Calcium Fly-Ashes as Stabilizers	70
Conclusions	71
CHAPTER 8 INTERACTIVE DISCUSSION OF ALL RESULTS	73
Introduction	73
Model 1: Regression Modeling with % Expansion without Lime as Response Variable for the Four Clay Soil Samples	73
Model 2: Regression Modeling with % Expansion with 6% Lime as Response Variable for the Four Clay Soil Samples	76
Model 3: Regression Modeling with % Expansion without Lime as Response Variable for Soil Samples from FM 1382 and IH 45	77
Model 4: Regression Modeling with % Expansion with 6% Lime as Response Variable for Soil Samples from FM 1382 and IH 45	79
Model for Determination of Amount of Expansion Experienced by Sulfate Bearing Clay Soils	81
Conclusions	82
CHAPTER 9 CONCLUSION	85
Overall Conclusions	85
Subjects Proposed for Further Investigation	86
CHAPTER 10 IMPLEMENTATION OF RESULTS	89
REFERENCES	93

	Page
APPENDIX A	97
Locations from which Soil Samples Were Taken Along FM 1382	99
Locations from which Soil Samples Were Taken Along IH 45	100
APPENDIX B	101
Relation Between PH of Clay Soils and Amount of Expansion Encountered	103

LIST OF FIGURES

		Page
1	Schematic Outline of Testing and Reporting Procedure	4
2	Wenner Array of Electrodes Used in Soil Electrical Conductivity Determinations (5)	7
3	Volume of Soil Measured Using Wenner Array Method (5)	7
4	Concentration of Single-Salt Solutions in Milliequivalents per Liter as Related to Electrical Conductivity (4)	9
5	Concentration of Single-Salt Solutions in Percent as Related to Electrical Conductivity (4)	10
6	Osmotic Pressure of Saturation Extracts of Soils as Related to Electrical Conductivity (4)	11
7	Layer Structure of a 2:1 Clay Mineral (Smectite) (10)	15
8	Layer Structure of Mica Mineral (10)	16
9	Layer Structure of 1:1 Clay Mineral (Kaolinite) (10)	16
10	Arrangement of H ₂ O Chains Linking a Divalent Exchange Cation on the Surfaces of a) a 1.5 nm Hydrate of Vermiculite and b) a 2 nm Hydrate of Smectite (10)	17
11a	Expansion of Soil Samples from FM 1382 Containing 6% Lime	32
11b	Expansion of Soil Samples from FM 1382 Containing No Lime	32
12a	Expansion of Soil Samples from IH 45 Containing 6% Lime	33
12b	Expansion of Soil Samples from IH 45 Containing No Lime	33
13a	Expansion of Soil Samples Containing 6% Lime vs. Sulfate Content	34
13b	Expansion of Soil Samples Containing No Lime vs. Sulfate Content	34
14	Expansion of Samples Containing No Lime. Sample on Left Contains Less than 0.2% Sulfates and Sample on Right 0.8% Sulfates.	36

	Page	
15	Samples Containing 6% Lime. The Two Samples on the Left Contain 0.8% Sulfates and Expanded 18%. The Sample on the Right Contains Less than 0.2% Sulfates and is Still Close to Original Size	37
16	Two Soil Samples with 0.8% Sulfates. Sample on the Left Contains 6% Lime and Expanded 6% More than the Sample on the Right Which Contains No Lime	38
17a	Expansion of Beaumont Clay Samples vs. Time	40
17b	Expansion of Eddy Clay Samples vs. Time	40
17c	Expansion of Houston Black Clay Samples vs. Time	41
17d	Expansion of Kaolinitic Samples	41
18	Relation Between Electrical Conductivity and Natural Sulfate Content of Soil Samples from FM 1382 and IH 45	46
19	Regression Line for Electrical Conductivity and Sulfate Content	46
20a	Electrical Conductivity vs. Sulfate Content of a Beaumont Clay	47
20b	Electrical Conductivity vs. Sulfate Content of an Eddy Clay	47
20c	Electrical Conductivity vs. Sulfate Content of a Houston Black Clay	48
20d	Electrical Conductivity vs. Sulfate Content of Kaolinite	48
20e	Electrical Conductivity vs. Chloride and Sulfate Content	50
21	Electrical Conductivity Values of the Four Clay Soils vs. Sulfate Content	51
22	Regression Line Fitted through Mean Values of Electrical Conductivity for Different Sulfate Contents	51
23a	Dielectric Constant vs. Frequency for an Eddy Clay	60
23b	Dielectric Constant vs. Frequency for a Beaumont Clay	60
23c	Dielectric Constant vs. Frequency for a Houston Black Clay	61
23d	Dielectric Constant vs. Frequency for a Kaolinitic Clay	61
24	Relation Between the Dielectric Constant and the Amount of Added Sulfates	62
25	Relation Between the CEC and the Range of ϵ_0 -Values	64

	Page
26 Relation Between CEC and Range of α -Values	64
27a Expansion of an Eddy Clay Upon Stabilization with Various Low Calcium Fly-Ashes	66
27b Expansion of a Beaumont Clay Upon Stabilization with Various Low Calcium Fly-Ashes	67
27c Expansion of a Houston Black Clay Upon Stabilization with Various Low Calcium Fly-Ashes	68
27d Expansion of a Kaolinitic Clay Upon Stabilization with Various Low Calcium Fly-Ashes	68
28 Expansion of Eddy Clay from FM 1382 Site No. 7 Upon Stabilization with Montecello Low Calcium Fly-Ash	69
29 The Average Amount of Expansion for Each Stabilizer vs. the Calcium Content of the Stabilizer	70
30 Battery Driven Digital Scale	90
31 Hand Held Electrical Conductivity Meter	90
32 Relation Between pH of Clay Soils and the Amount of Expansion After Lime Stabilization	103

LIST OF TABLES

		Page
1	Bureau of Soils Data for Reducing Soil Paste Resistance Readings to Values at 15.5 °C (60 °F)(4)	12
2	Ratios of Lime and Sulfates Added to the Four Clay Soil Samples	23
3a	Composition of Soil Samples on which Electrical Conductivity Measurements were Performed (Samples Containing Natural Soil and Sulfates)	26
3b	Composition of Soil Samples on which Electrical Conductivity Measurements were Performed (Samples Containing Natural Soil, Sulfates and Chlorides)	26
3c	Composition of Soil Samples on which Electrical Conductivity Measurements were Performed (Samples Containing Natural Soil, Sulfates and Lime)	27
4a	Amount of Soluble Sulfates in the Four Clay Soil Samples	44
4b	Amount of Soluble Sulfates in the Soil Samples Obtained from FM 1382 and IH 45	44
5	Mean Electrical Conductivity Value at Different Sulfate Contents, with Standard Deviation	52
6	Comparison between Electrical Conductivity Measurements of Single-Salt Solution and Soil Solutions at the Same Sulfate Concentration	53
7a	Cation Exchange Capacities for the Four Clay Soil Samples	58
7b	Cation Exchange Capacities for Soil from FM 1382 and IH 45	58
8	Values for α Calculated from Known Values of ϵ at Different Frequencies with Values for CEC	62
9	Results of Various Experimental Procedures for the Four Clay Soil Samples (Without Lime)	74

		Page
10	Pearson Correlation Coefficients for Expansion of Clay Soil Samples Containing No Lime, and Other Parameters (19)	75
11	Results of Various Experimental Procedures for the Four Clay Soil Samples (With Lime)	76
12	Pearson Correlation Coefficients for Expansion of Clay Soil Samples Containing 6% Lime, and Other Parameters (19)	76
13	Results of Various Experimental Procedures for Soil Samples from FM 1382 and IH 45 (Without Lime)	78
14	Pearson Correlation Coefficients for Expansion of Soil Samples from FM 1382 and IH 45 Containing No Lime, and Other Parameters (19)	78
15	Results of Various Experimental Procedures for Soil Samples from FM 1382 and IH 45 (With Lime)	80
16	Pearson Correlation Coefficients for Expansion of Soil Samples from FM 1382 and IH 45 Containing 6% Lime, and Other Parameters (19)	80

SUMMARY

Hydrated lime is in many cases added to clay soils to reduce the amount of expansion. The lime-soil-water system creates a high pH environment which enhances flocculation. However, when sulfates are present in the soil, the lime reacts with the sulfates to form ettringites, an expandable mineral. Ettringites can expand up to 200% of their original size. The formation of ettringite causes great economical as well as structural problems.

This report describes a method that can be used to determine the sulfate content of in situ soil. The sulfate content of soil is related to electrical conductivity measured on a soil paste with a specific soil-water ratio. The sulfate content is also related to the amount of expansion that occurs upon lime stabilization. The report proposes equations that give an approximate amount of expansion due to sulfates in the soil as a function of the sulfate content and the electrical conductivity. The approximate amount of expansion before and after lime stabilization can be obtained by using the relationship between expansion, electrical conductivity, and sulfate content. The only parameter needed to determine an approximate amount of expansion is the electrical conductivity. Electrical conductivity can be measured with great ease on a soil paste. This measurement can be made in the field, and does not require expensive laboratory equipment.

The report also discusses alternative methods to stabilize sulfate bearing clay soils. Low calcium fly-ash stabilizers are proposed for stabilizing sulfate bearing clay soils. The low calcium stabilizers proposed are Montecello, Big Brown, and Sandow fly-ashes. These fly-ashes performed well in keeping some sulfate bearing clay soils from expanding.

CHAPTER 1

INTRODUCTION

Lime is an inexpensive and available mineral which, when added to clay soils, raises the pH of the soil, adds stability, and increases strength. Lime is used to stabilize clay soils in various applications, of which the road industry is one primary example.

However, when using lime to stabilize some sulfate bearing soils, excessive heave which is detrimental to roadways and other constructions is induced. Research indicates that this heave may be due to the reaction between calcium in the lime and naturally occurring sulfates in the soil which leads to the formation of the expandable minerals ettringite and thaumasite (1). Alternative methods for stabilizing sulfate bearing soils have been investigated. For example, Ferris et al. recommended the use of barium compounds as alternative stabilizing agents when stabilizing sulfate bearing soils (2).

Before such alternative methods can be employed, however, sulfate bearing soils need to be identified. An easy-to-perform field test is needed to determine whether sulfates are present in soil.

The electrical conductivity of the soil is a relatively easily measured parameter that relates to the sulfate content of soil (3). A high electrical conductivity could indicate the presence of sulfates, and electrical conductivity measurement can be used to locate possible problem sites. The mineralogy of the clay may have an effect on the formation of ettringite. In this thesis, four different clay soils will be subjected to expansion tests after the addition of lime and sulfates, to investigate the relative volume changes of the four standard soil samples at different sulfate contents.

The specific objectives of this study are summarized below:

- 1) To identify the cause of heave of those clay soils that expanded after lime stabilization.

- 2) To establish a field test that can locate soils containing sulfates. The hypothesis states that the electrical conductivity of soil has a strong relation to the sulfate content in the soil, and since electrical conductivity is easily measurable, it could be established as a field test for the determination of possible sulfate induced heave in clay soils.
- 3) To investigate the possible relationship between the cation exchange capacity (CEC) of the clay and the amount of heave that occurs when sulfate bearing soils are stabilized with lime. (CEC is an inherent soil property that relates to the mineralogy of different clay soils and to their specific surface area.)
- 4) To determine the minimum amount of sulfates that cause the formation of expandable ettringite.
- 5) To attempt to identify an alternative stabilizing agent to stabilize sulfate bearing soils.

A discussion of the two major types of experiments performed follows. The first experiment tests swelling to determine the expansion of soil samples containing natural sulfates and lime as well as added sulfates and lime. It will also determine the expansion of soil samples which were stabilized with low calcium fly-ash like: Sandow, Big Brown, and Montecello. The second set of experiments were performed to determine the presence of sulfates in the soil samples. The amount of sulfates was determined by two different electrical conductivity methods, the first being the standard EPA procedure and the second using a permittivity probe which measures both electrical conductivity and the dielectric constant of the soil. As a control measure, the amount of sulfates was also determined with an EPA procedure for the determination of total sulfate content.

Other experiments performed were the CEC determination and the dielectric constant (DC) determination. These experiments were performed in order to gain a better understanding of the properties of clay which could have an influence on expansive behavior. The results and conclusions of each of the above mentioned

experiments are presented in the chapters following the description of the methods used to perform the experiments.

Finally, a conclusion is made which describes how the results of the different experiments interact with each other. The conclusion states how electrical conductivity could be used to determine locations of sulfate bearing soils and makes suggestions about alternative procedures by which sulfate bearing soils could be stabilized. The following flow chart describes the layout of this study schematically.

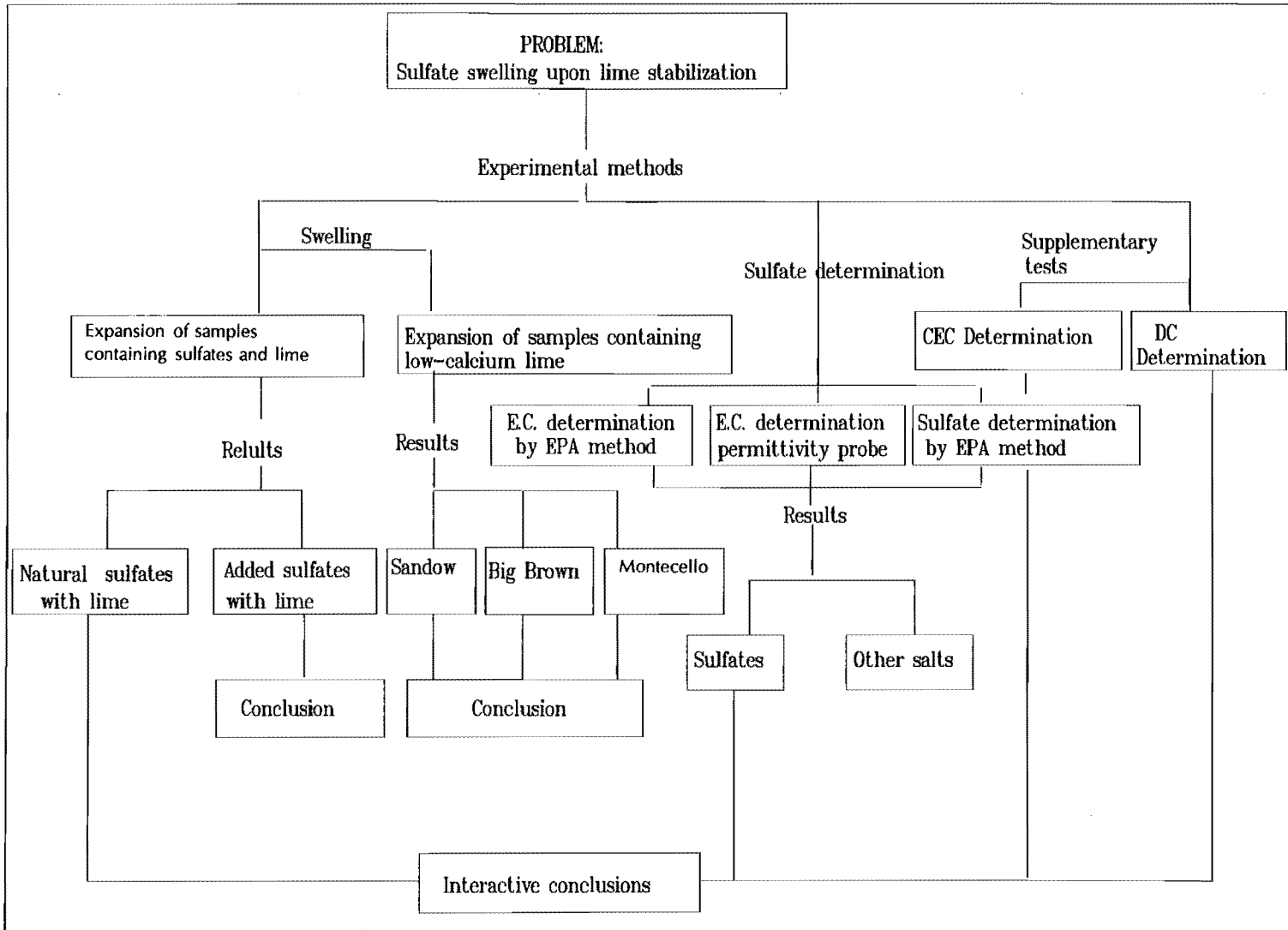

Figure 1. Schematic Outline of Testing and Reporting Procedure.

CHAPTER 2

LITERATURE REVIEW

INTRODUCTION

The general idea of this study is that electrical conductivity of soils can be related to the sulfate content in the soil. An attempt will also be made to suggest alternative stabilization methods for sulfate bearing soils.

In order to develop a relationship between electrical conductivity and sulfate content, it is necessary to have an understanding of the basic electrical properties associated with soils as well as an understanding of the mineralogy of the different soils under investigation. This chapter will discuss the electrical properties of soil as well as the basic mineralogy of the soils under investigation.

This chapter also provides an overview of the chemistry involved in the formation of ettringites, which is an expandable mineral formed when sulfate bearing soils are stabilized with lime. State-of-the-art stabilization methods are also discussed in this chapter.

CONDUCTIVITY OF SOILS

Electrical Conductivity in Soils

Electrical conductivity is defined as the reciprocal of the electrical resistivity (4). Resistivity is the resistance (in ohms) of a metallic or electrolytic conductor, which is 1 cm long and has a cross sectional area of 1 cm². Hence, electrical conductivity is expressed in reciprocal ohms per centimeter, or Siemens (mhos) per centimeter (4).

Soil minerals are insulators, and electrical conductivity of soil is primarily facilitated through pore water which contains electrolytes (5). Exchangeable cations contribute little to the electrical conductivity of soils because of the abundance and increased mobility of the soluble electrolytes (5). Electrical conductivity is influenced by the amount and size of the water pores in soil, as well as the water content and the concentration of electrolytes in the soil (5). The salt content of a

saturated soil paste can be estimated by using electrical conductivity measurements (4). A more accurate estimate can be obtained by electrical conductivity measurements of the water extracted from the soil (5).

Conventional Methods for Measuring Soil Electrical Conductivity

Soil salinity or soil electrical conductivity measurements can be determined from measurements of bulk electrical conductivity using the four electrode method (6). In this method, called the Wenner Array method, four electrodes are placed in a straight line with equidistant spaces between them (5). The electrical resistance is measured across the inner pair of potential electrodes (P_1 P_2), while passing a constant current between the outer pair of current electrodes (C_1 C_2), as illustrated in Figure 2. The apparent bulk soil conductivity is calculated as (1):

$$EC_a = \frac{1000}{2 \pi 30.48 a} \times \frac{f_t}{r_t}$$

where EC_a = Apparent soil electrical conductivity in mhos/cm,
 r_t = Resistance in ohms at temperature t in °C,
 a = Inter-electrode spacing in cm, and
 f_t = Factor to adjust reading to reference temperature of 25°C.

The volume of soil over which the electrical conductivity is measured with the Wenner Array method includes all the soil between the inner pair of electrodes from the soil surface to a depth about equal to the inter-electrode spacing. This volume is illustrated in Figure 3.

Soil electrical conductivity can also be determined using an Electrical Conductivity (EC) probe which is directly inserted into the soil (5). The latter procedure is not convenient for routine field determinations but is very accurate and can be used for calibration purposes (5).

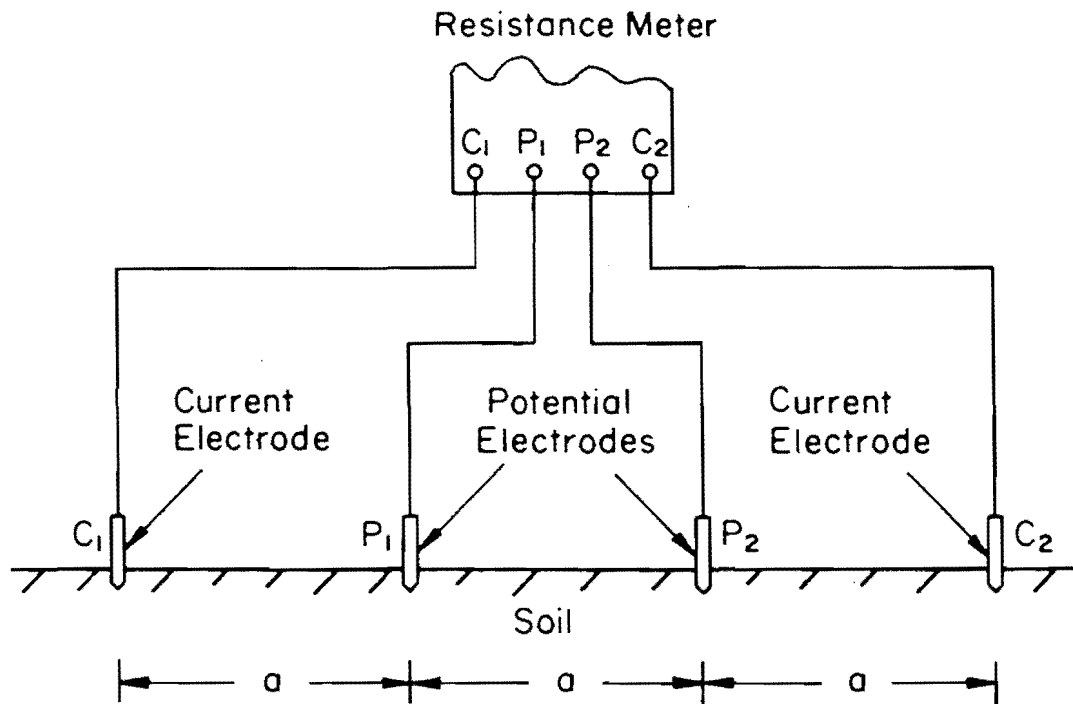

Figure 2. Wenner Array of Electrodes Used in Soil Electrical Conductivity Determinations (5).

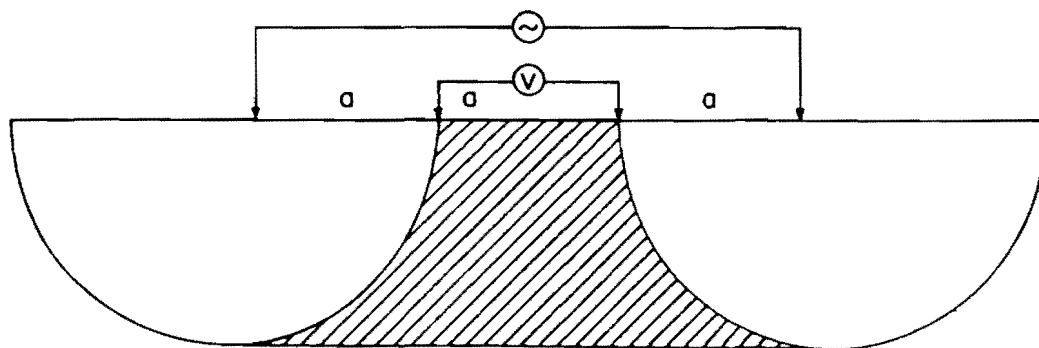

Figure 3. Volume of Soil Measured Using Wenner Array Method (5).

Relation of Conductivity to Salt Content and Osmotic Pressure

The relationships between electrical conductivity and salt content of different solutions are shown graphically in Figures 4 and 5 (4). The curves for Na_2SO_4 and the chloride salts almost coincide, but MgSO_4 , CaSO_4 , and NaHCO_3 have lower conductivities than the other salts at equivalent concentrations. When the concentration is given as percent salt, the curves are more widely spread (4).

Experimental work done by salinity laboratories indicates a strong relationship between the electrical conductivity and osmotic pressure of a solution. Figure 6 shows this relationship (4). In the range of electrical conductivity that will permit plant growth, the osmotic pressure is given by:

$$OP = 0.36 \times EC \times 10^3$$

where OP = Osmotic pressure.

Since the electrical conductivity of the soil is related to osmotic pressure, the latter could also be used to determine the salt content in soils.

The Effect of Soil:Water Ratios on the Electrical Conductivity

When the extract is obtained from solutions with soil:water ratios of 1:1 and 1:5, conductivity measurements are used for estimating salinity (4). For a chloride salt, the electrical conductivity results will only be slightly influenced by the water content, but with low soluble salts like sulfates and carbonates, the apparent amount of salt will be dependent on the soil:water ratio. For this reason it is necessary to report electrical conductivity measurements at specific soil:water ratios (4).

The Effect of Temperature on Conductivity

The electrical conductivity of soil increases approximately 2% with each degree centigrade increase in temperature (4). The resistance of 9 soils at 13 temperatures was measured and the average relation of resistance to temperature calculated (4). This relationship is given in Table 1.

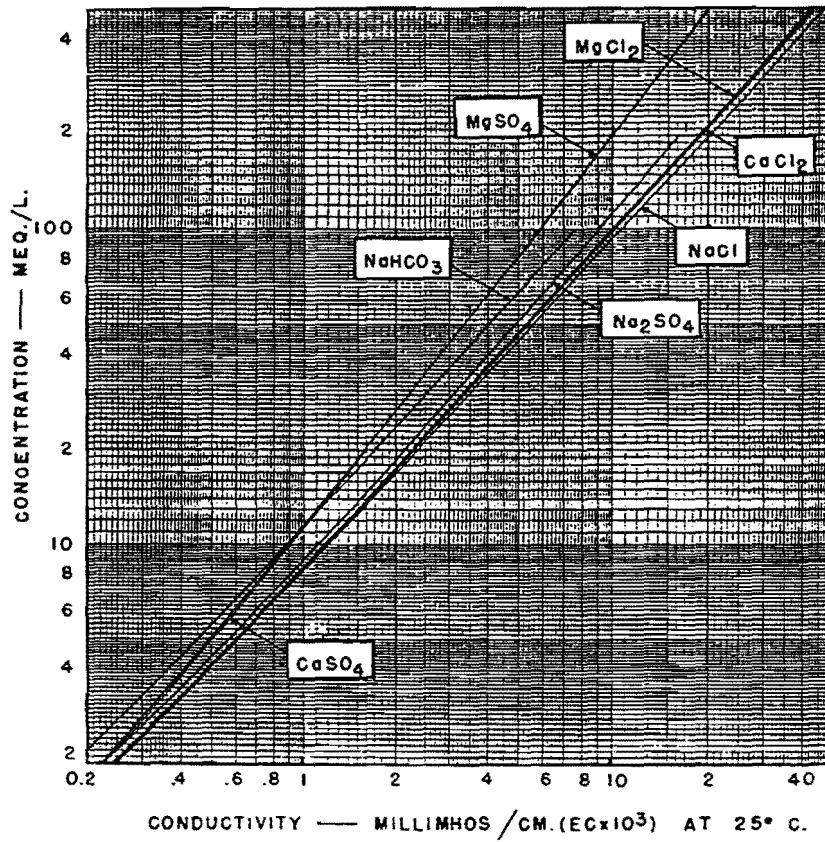

Figure 4.

Concentration of Single-Salt Solutions in Milliequivalents per Liter as Related to Electrical Conductivity (4).

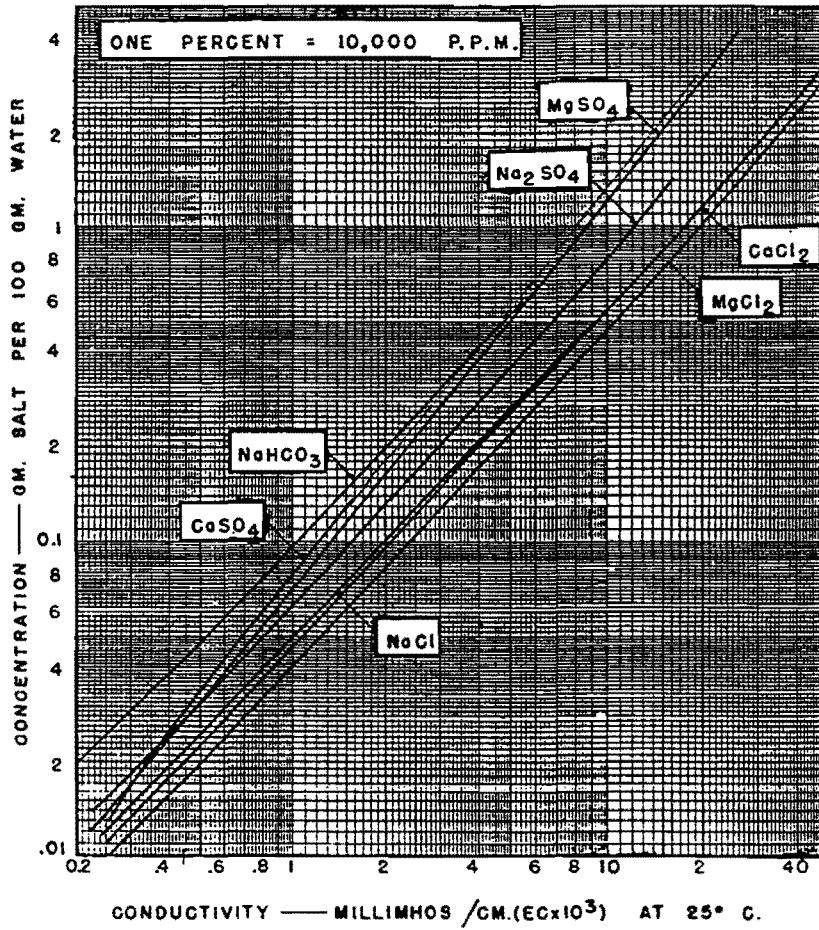

Figure 5. Concentration of Single-Salt Solutions in Percent as Related to Electrical Conductivity (4).

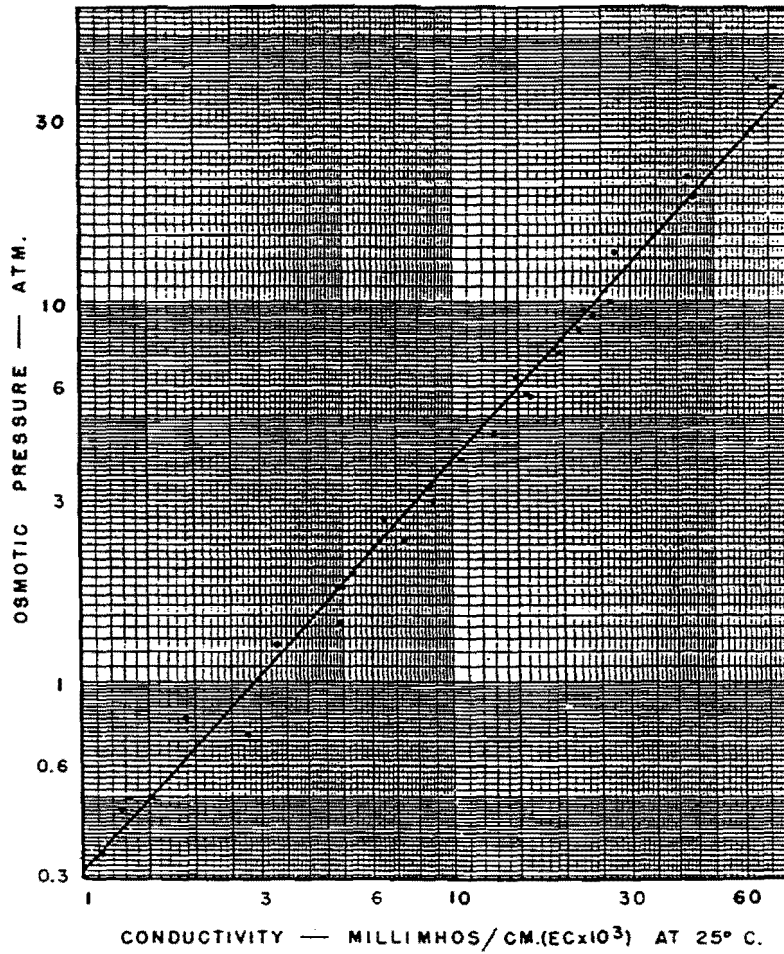

Figure 6. Osmotic Pressure of Saturation Extracts of Soils as Related to Electrical Conductivity (4).

Table 1. Bureau of Soils Data for Reducing Soil Paste Resistance Readings to Values at 15.5°C (60°F) (4).

°C (°F)	Ohms				
	1.000	3.000	5.000	7.000	9.000
4.4 (40)	735	2 205	3 675	5 145	6 615
10.0 (50)	867	2 601	4 335	6 069	7 803
15.5 (60)	1 000	3 000	5 000	7 000	9 000
21.1 (70)	1 140	3 420	5 700	7 980	10 260
26.6 (80)	1 294	3 882	6 470	9 050	11 646
32.2 (90)	1 406	4 380	7 300	10 220	13 140

Electrical Conductivity Measurements with Permittivity Probe

The dielectric permittivity and conductivity meter is a device that measures the dielectric constant and specific conductivity of various materials (7). This device can be used to perform nondestructive measurements in the field or in the laboratory. Useful correlations between measured parameters and other physical soil properties can be made. One aim of this investigation is to relate the dielectric properties and electrical conductivity measured with this probe to the sulfate content of the soil under investigation. The dielectric constants of soils and other solids are between 2 and 4, while the dielectric constants of water is 78. Because of this difference, the moisture content of soil could be usefully related to the dielectric constant measurement (7).

MINERALOGY OF CLAY SOILS

The four different clay soils used in this investigation were:

- a) Eddy clay loam from the Dallas area alongside FM 1382,
- b) Beaumont clay,
- c) Houston Black clay, and
- d) Kaolinite.

Other soils samples used were natural soil samples obtained from along IH 45 near Palmer in Northeast Ellis County, and from FM 1382 in Southwest Dallas County. The exact location where each soil sample along FM 1382 and IH 45 was obtained is indicated on the maps in Appendix A.

The Eddy clay loam is a very shallow and well drained soil which overlays the Austin chalk geologic formation (9). The surface layer is about 102 mm (4 inches) thick, alkaline, and grayish brown in color. The underlying material is white, soft, chalky limestone (9). Permeability of this soil is low, and the erosion hazard is severe.

The Houston black clay is a moderately well drained soil with a moderately alkaline surface layer (9). From a depth of 152 mm (6 inches) to 965 mm (38 inches) the soil has a very dark grey to black color. Permeability is very low, and the available water capacity is high. The soil has a very high shrink-swell potential with low strength (9).

Both the Beaumont clay and the Houston black clay are vertisols which means that they are strongly developed soils (10). The most abundant mineral in both of these soils is dioctahedral smectite which has a 2:1 mineral structure as shown in Figure 7. The charge per formula weight is 0.6 to 0.25, and the interlayer contains exchangeable cations which could be aluminum, iron, or magnesium. Smectites have a very high surface area that shrinks upon drying and swells upon wetting. This shrink-swell behavior is most pronounced in the Vertisol order and can lead to engineering problems when houses, roads, and other structures are built on smectitic soils (10).

The Eddy clay loam has a mixed mineralogy with smectites, mica, Hydroxy-interlayer smectite (HIS), and kaolinite (11). Mica minerals also have a 2:1 layer structure, but instead of having only Si^{4+} in the tetrahedral sites, one fourth of the tetrahedral sites are occupied by Al^{3+} which causes one excess negative charge per formula unit (10). This negative charge is balanced by a monovalent cation, commonly K^+ , that occupies the interlayer sites between the 2:1 layers (10). Micas weather to vermiculites and smectites by losing the interlayer K^+ . The layer structure of mica is shown in Figure 8.

Hydroxy-interlayer smectite is smectite with a hydroxy-Al mineral in the interlayer (between the 2:1 layers). The combination of the 2:1 layer with the hydroxy-Al in the interlayer gives a structure similar to that of chlorite; therefore, these minerals are also called secondary chlorites (10). The interlayer hydroxy-Al prevents smectite from shrinking and swelling as it normally would (10).

Kaolinite has a 1:1 layer structure, is dioctahedral, and contains Al^{3+} in the octahedral sites and Si^{4+} in the tetrahedral sites (10) which makes it electrically neutral. The layer structure is shown in Figure 9. Kaolinite is an abundant mineral

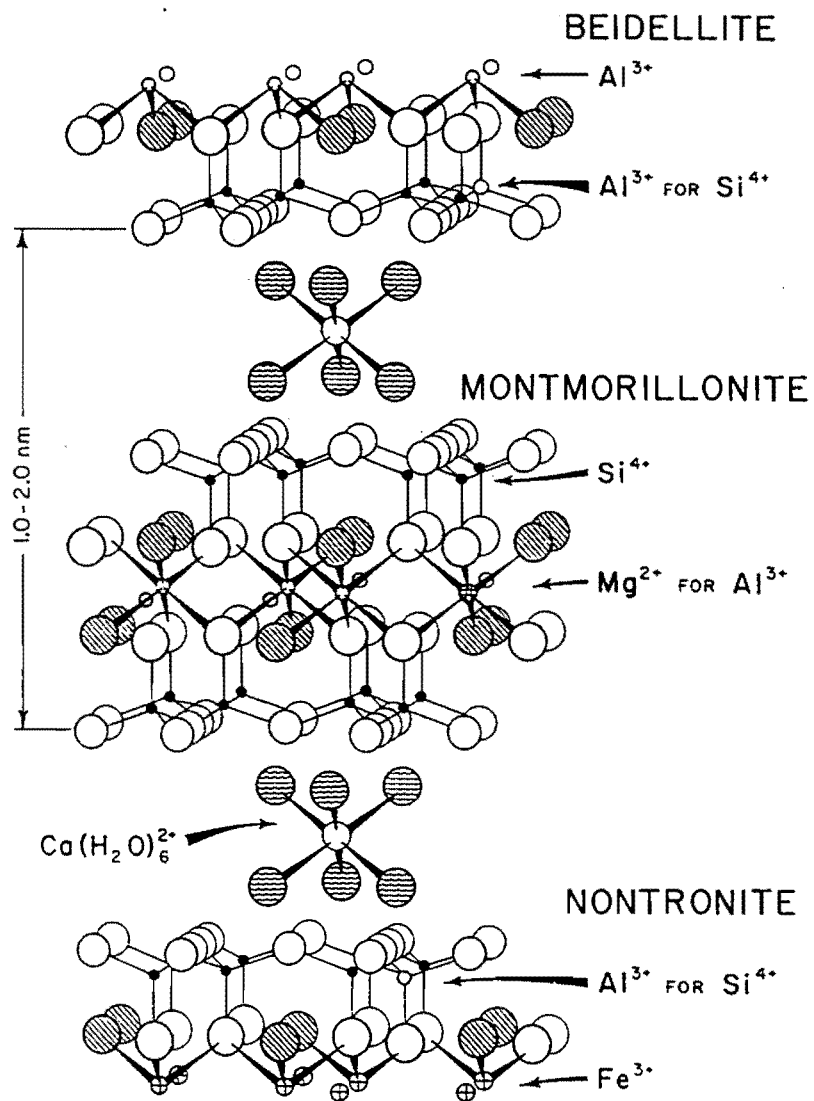

Figure 7. Layer Structure of 2:1 Clay Mineral (Smectite) (10).

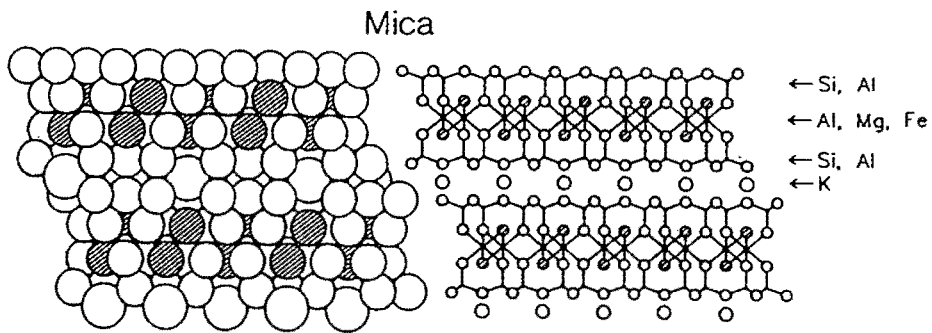

Figure 8. Layer Structure of Mica Mineral (10).

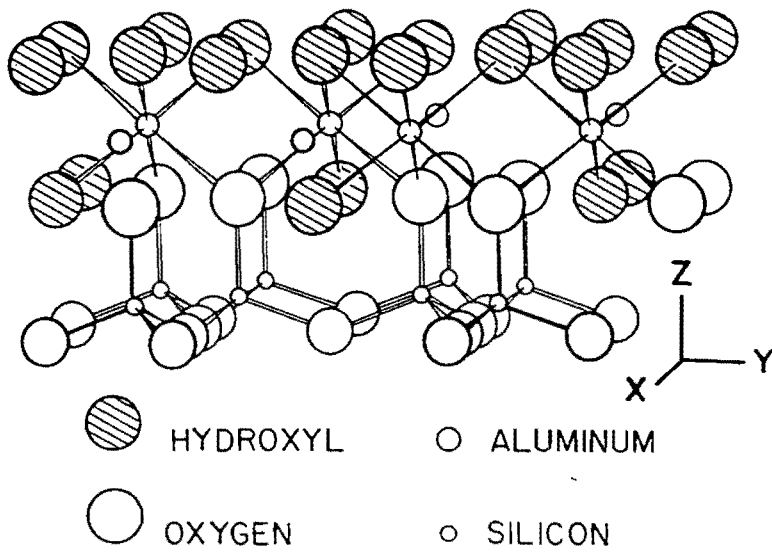

Figure 9. Layer Structure of 1:1 Clay Mineral (Kaolinite) (10).

in weathered soils (10). Cation exchange capacities and surface areas of kaolinite are typically low because of the small amount of substitution. Kaolinite is mainly formed from weathering of primary and secondary minerals that contain large amounts of Si and Al. Kaolinites form mostly from clay sediments and igneous rock (10).

Although a consensus of opinion on the most appropriate model of clay expansion has not been reached yet, the observation that layer silicates, such as smectites and vermiculites, approach maximum hydration beyond which they do not expand, can be explained by a model of H-bonding (12). This model proposes that the hydration water acts as a dielectric link between the exchangeable cation and the surface oxygen atoms (12). In vermiculite, the tetrahedral negative charge is distributed over relatively few surface oxygen atoms, so that an arrangement occurs where the hydration water is only two molecules thick, as shown in Figure 10a. The smectite tetrahedral negative charge is distributed more diffusely which favors a more extended arrangement of dielectric linkages and a necessarily greater interlayer spacing shown by the structure in Figure 10b. A physically reasonable explanation of the inability of clays to expand beyond the spacings shown in Figures 10a and 10b could be that any further reduction in energy due to additional hydration of exchange cations would be balanced by reduced efficiency of charge transfer to surface oxygens (12).

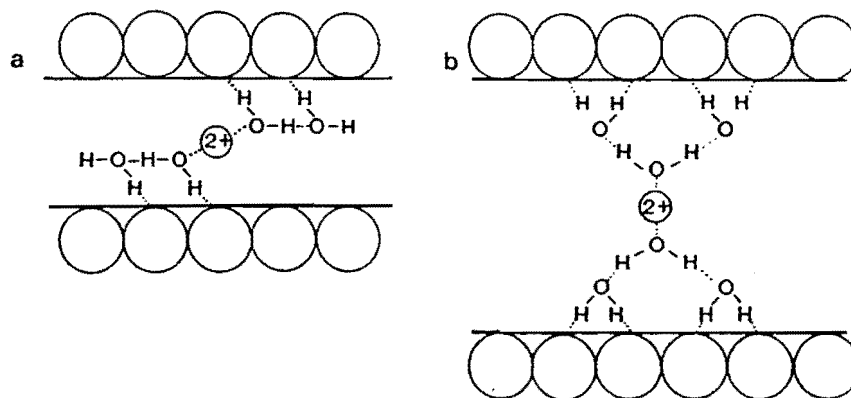

Figure 10. Arrangement of H₂O Chains Linking a Divalent Exchange Cation on the Surfaces of a) a 1.5 nm Hydrate of Vermiculite and b) a 2 nm Hydrate of Smectite (10).

STABILIZATION OF BASE COURSES WITH LIME

Soils often require stabilization to enhance mechanical stability, to improve durability, and to reduce volume change potential (13). Compaction is the most common form of soil stabilization. However, when dealing with high plasticity soils, compaction alone is often not enough. Alternative soil stabilization techniques are mostly used when more than 25% of the soil is smaller than 2 μm (0.002 mm) with a plastic index (PI) that exceeds 10 (13).

Pozzolatically induced long-term strength gain is achieved by mixing lime into clay soils. Many clays are reactive, and their strengths can double, and in some cases even quadruple, upon lime stabilization (13).

When lime is added to clay soils, the divalent calcium cations in the lime almost always replace the exchangeable cations adsorbed at the clay surface (13). This cation exchange results in stabilization and reduction in size of the diffused water layer. Clay particles approach each other more closely and flocculation occurs. The lime-soil-water system creates a high pH environment which enhances flocculation (10). The flocculation leads to increased internal friction which results in greater shear strength and workability increases due to the change of texture from a plastic clay to a more sand-like material (13).

The amount of lime to be used for the treatment of the subgrade must be determined by laboratory testing and empirical methods recognized in the literature (13). The optimum lime content is normally based on strength improvement.

The steps involved in stabilization or modification with lime include scarification and partial pulverization of the soil, lime spreading, wetting, mixing of lime with the soil, compaction to maximum practical density, and curing prior to placing subsequent layers, or a wearing course (13).

FORMATION OF ETTRINGITES

Lime treatment for stabilization of subgrade soils was used for an approximately 5 km (three mile) section of arterial street in Las Vegas, Nevada. Two years after construction, signs of distress began to appear in the form of

surface heaving and cracking (14). Subsequent investigations showed that heave developed in the lime-treated soils containing sulfates such as sodium sulfates and gypsum (calcium sulfates). The heave is mainly due to the growing of disruptive volumes of hydrous calcium hydroxide sulfate minerals (3). Minerals that were found in abundance in the heaved areas were thaumasite, a complex calcium-silicate-hydroxide-sulfate-carbonate-hydrate, and ettringite, a calcium-aluminum-hydroxide-sulfate-hydrate mineral. The mechanism of heave was found to be a complex function of available water, the percentage of soil clay, and cation exchange capacity (CEC) (3).

The sulfate induced heave problem in lime treated clays did not receive recognition until the Las Vegas case in 1986, and the interaction of lime and sulfate bearing clay soils is still not fully understood. A current working hypothesis proposed by Petry and Little (1) is discussed in the following paragraph.

When lime is added to clay soil, the pH rises and aluminum and siliceous pozzolans are released to form calcium silicate hydrate (CSH) and calcium aluminum hydrate (CAH). The presence of sulfates confounds this reaction and leads to the formation of ettringite, which is an expandable mineral. The formation of ettringite is favored in low alumina environments. Ettringite is stable in both wet and dry conditions and can expand to a volume equal to 227% of the total volume of the reactant solids (1). Ettringite can be transformed to thaumasite (another expandable mineral), when a sufficient amount of carbonate and dissolved silica is present in the soil system at temperatures between 4.5 and 15 °C (40 and 59 °F).

CHAPTER 3

METHODOLOGY

INTRODUCTION

In this chapter, the methods used to perform various tests to investigate the heaving problems related to sulfate bearing soils will be outlined. Two major types of tests were performed in this investigation:

- a) Expansion tests were performed to determine the expansive properties of soils that contain natural sulfates and soil that contain added sulfates, upon hydrated lime stabilization and also upon stabilization with low calcium fly-ash.
- b) Electrical conductivity measurements were performed to investigate a possible relationship between electrical conductivity in soils and the sulfate content in soils.

The tests were performed on two groups of soil samples:

- a) Four naturally occurring clay soils which are often encountered in Texas, namely: Houston black clay, Beaumont clay, Eddy clay, and a kaolinitic clay. The locations from which these soils were obtained and the mineralogy of the clay soils are discussed in Chapter 1.
- b) Soil samples from various locations along Interstate Highway (IH) 45 and Farm to Market Road (FM) 1382, near Dallas, Texas, where heaving problems have been encountered. These soils vary from sandy loams to heavy clays.

Additional tests that were performed to gain a better understanding of the soil mineralogy and behavior are listed below.

- 1) Cation exchange capacity (CEC) determination
- 2) Determination of soluble sulfate content
- 3) Dielectric constant determination

METHOD FOR DETERMINATION OF EXPANSION OF SULFATE BEARING CLAY SOILS

A set of experiments was performed to determine the amount of expansion that occurs in soils containing different amounts of natural sulfates, added sulfates, and hydrated lime. The aim was to determine the amount of sulfates that causes expansion in lime stabilized soils. The expansion tests were conducted on 4 different clay soil samples and various samples obtained from IH 45 and FM 1382, both in Dallas County, near Ceda Hill, Texas. These soils were chosen because they are frequently encountered in the Texas area, and Eddy clay has a history of swelling excessively when stabilized with lime. The expansion of several other soil samples along IH 45 and FM 1382 near Palmer in Dallas County was also investigated because heaving problems were encountered along these roads.

The way in which these experiments were performed is as follows:

- 1) Soil samples were collected from different locations in Texas, as described previously.
- 2) The samples were sun dried and crushed to pass the 0.425 mm (no. 40) sieve.
- 3) After drying and crushing, 3 kg of each of the 4 clay soil samples were mixed with lime, water, and calcium sulfate ($\text{CaSO}_4 \cdot 2\text{H}_2\text{O}$ - gypsum) in ratios described in Table 2. The soil was weighed into a container after which the lime and then the sulfates were added. The container was closed tightly and turned over for 2 minutes to mix the dry ingredients. After mixing the dry ingredients, 15% water was gradually added to the mix while the soil was constantly stirred to ensure a uniform mixture. Fifteen percent water was used because when mixed with the soil, it

Table 2. Ratios of Lime and Sulfates Added to the Four Clay Soil Samples.

*Sample Number	Amount of soil (kg)	Amount of lime (%)	Amount of sulfates (%)	Amount of water (%)
1	3	0	0	15
2	3	0	0.2	15
3	3	0	0.4	15
4	3	0	0.6	15
5	3	0	0.8	15
6	3	6	0	15
7	3	6	0.2	15
8	3	6	0.4	15
9	3	6	0.6	15
10	3	6	0.8	15

* These 10 compositions were made up for each of the 4 clay soil samples, which resulted in a total of 40 samples.

resulted in a workable consistency which facilitated subsequent compaction tests. Previous investigation (3) showed that 0.8% sulfates by weight seemed to be a relatively large amount of sulfates that occur naturally in most soils in the Texas area. Therefore, up to 0.8 % of sulfates were used in these mixes. Six percent lime is an average amount added to most clay soils in order to stabilize the soil. For this reason, the same amount of lime was added to the mixes in this investigation. The soil samples obtained from IH 45 and FM 1382 were mixed with 6% lime without the addition of sulfates. However, some of the soil samples contained natural sulfates. Three samples from each location were mixed with 6% lime, while one sample was not mixed with lime and served as a control sample. The samples were mixed with 15% water prior to compaction.

- 4) After the soil, lime, sulfates and water had been mixed, the samples were stored at 50% relative humidity at 25°C to cure for a period of 12 hours.
- 5) The samples were then compacted using the standard proctor compaction method (15).
- 6) Each of the compacted cores was wrapped in a rubber membrane with a porous stone at the top and the bottom of each core.
- 7) The core samples were then placed in pans filled with 2 cm of water to allow the samples to soak up the water.
- 8) This whole experimental setup was placed in a 10°C constant temperature room with a controlled relative humidity of 100%. These cold, wet conditions seem to encourage the formation of ettringites (1).
- 9) The samples were kept under these conditions to expand freely for a period of 3 months during which the expansion of the samples was frequently monitored.

METHOD FOR DETERMINING ELECTRICAL CONDUCTIVITY WITH PERMITTIVITY PROBE AND THE EPA METHOD NO. 9050

Because of sulfate related heave in lime stabilized soils, a need developed to determine the sulfate content of in situ soils. Electrical conductivity tests were performed to investigate a possible relation between the amount of sulfates and the electrical conductivity of soil samples. Two methods were used for determining the electrical conductivity. The first method was a standard approved EPA procedure (16) and served as a control for a proposed method by a permittivity probe which could be used for field determination of electrical conductivity of the in situ soil. The following steps outline the procedure followed:

- 1) Samples of each of the four clay soils were mixed with lime and sulfates in ratios outlined in Tables 3a, b, and c. Each of the combinations 1 through 18 was repeated for each of the four clay soils under investigation.
- 2) For the electrical conductivity measurements with the permittivity probe, the samples were diluted to a 1:2 soil:water ratio with de-ionized water. Another set of conductivity measurements was taken on the samples diluted to a 1:4 soil:water ratio because the conductivity of low soluble salts like sulfates are influenced by the dilution (8). The permittivity probe measured electrical conductivity directly on the soil slurry.
- 3) Electrical conductivity measurements according to the EPA method were performed on a water extract taken from a 1:2 soil:water ratio mixture. The specific conductance of a sample was measured using a self-contained Wheatstone bridge-type conductivity meter (15). Whenever possible, the samples were analyzed at 25°C. If samples were analyzed at different temperatures, temperature corrections were made and results reported at 25°C.
- 4) Samples of soil obtained along IH 45 and FM 1382 were subjected to electrical conductivity tests only by the EPA method. No sulfates or lime were added to these samples.

Table 3a. Composition of Soil Samples on which Electrical Conductivity Measurements were Performed (Samples Containing Natural Soil and Sulfates).

Sample No.	Amount of Sulfates (%)
1	0
2	0.2
3	0.4
4	0.6
5	0.8
6	1.0

Table 3b. Composition of Soil Samples on which Electrical Conductivity Measurements were Performed (Samples Containing Natural Soil, Sulfates and Chlorides).

Sample No.	Amount of Sulfates (%)	Amount of Chlorides (%)
7	0	1.0
8	0.2	0.8
9	0.4	0.6
10	0.6	0.4
11	0.8	0.2
12	1.0	0

Table 3c. Composition of Soil Samples on which Electrical Conductivity Measurements were Performed (Samples Containing Natural Soil, Sulfates and Lime).

Sample No.	Amount of Sulfates (%)	Amount of Lime (%)
13	0	6
14	0.2	6
15	0.4	6
16	0.6	6
17	0.8	6
18	1.0	6

METHOD FOR INVESTIGATING SEVERAL LOW CALCIUM FLY-ASHES AS ALTERNATIVE STABILIZERS

An alternative stabilizer is needed whenever excessive heave is expected from sulfate bearing soils that are stabilized with lime. Most commonly used forms of lime used for stabilization are hydrated high calcium limes (13). The calcium reacts with the sulfates in the soil to form ettringites, as discussed in Chapter 1. Low calcium fly-ashes have been proposed as alternative stabilizing agents for sulfate bearing soils. The low calcium fly-ashes used in this investigation were:

- 1) Sandow from Rockdale, distributed by The Money Resources in San Antonio, Texas, which contains 13% calcium.
- 2) Montecello from Mt. Pleasant, distributed by the Lafarge Corporation in Dallas, Texas, and containing 8.47% calcium.
- 3) Big Brown from Fairfield, distributed by the Lafarge Corporation in Dallas, Texas, and containing 9.8% calcium.

Each of these low calcium fly-ashes was mixed with samples of the four clay soils used in this investigation as well as Sample No. 7 from FM 1382 which showed excessive heave after lime stabilization. The method followed to perform these expansion tests is similar to the method outlined for determination of expansion in soil samples discussed previously in this chapter. However, no sulfates were added to the soil prior to compaction, and the evaluation was based on the natural sulfate content of the various soil samples.

METHODS BY WHICH SUPPLEMENTARY TESTS WERE PERFORMED

Cation Exchange Capacity Determination

The CEC of all soil samples was determined by the EPA method No. 9081 (17). A soil sample is mixed with an excess of sodium acetate solution, resulting in an exchange of the added sodium cations for the matrix cations. Subsequently, the sample is washed with isopropyl alcohol. An ammonium acetate solution is then

added which replaces the adsorbed sodium with ammonium. The concentration of displaced sodium is then determined by atomic absorption, emission spectroscopy, spectrophotometer, or an equivalent means (17).

Method for Determination of Soluble Sulfate Content

EPA method No. 9038 (18) was used to determine the amount of soluble sulfates in the soil samples. The naturally occurring soluble sulfates in each of the four clay soil samples, as well as each of the samples obtained from FM 1382 and IH 45, were determined. The procedure involves converting the sulfate ion to a barium sulfate suspension under controlled conditions. The resulting turbidity is determined by a nephelometer, filter photometer, or spectrophotometer and compared with a curve prepared from standard sulfate solution (18).

Method for Determination of Dielectric Constants

Dielectric constants were only measured for the four clay soil samples under investigation. The dielectric constant measurement was made directly after the electrical conductivity measurement with the permittivity probe on the soil slurry with a 1:2 soil to water ratio. The measurement was made with the same probe as the one used for conductivity measurements at different frequencies ranging from 0 to 3 Gigahertz.

CHAPTER 4

RESULTS FROM EXPANSION TESTS

INTRODUCTION

This chapter presents and discusses the results obtained from expansion tests. Expansion tests have been performed on samples obtained along FM 1382 and IH 45 and on the four clay soil samples. The results from expansion tests on samples obtained from FM 1382 and IH 45 are discussed separately from the results obtained from the four clay soil samples. The most important difference between these two groups of samples is that the samples from FM 1382 and IH 45 contain only natural sulfates, while calcium sulfate (gypsum) was added in different quantities to the four clay soils, as described in the previous chapter.

In each case, the percentage of volumetric expansion was calculated by measuring the percentage increase in the circumference and height of the sample.

RESULTS OF EXPANSION TESTS PERFORMED ON SAMPLES FROM IH 45 AND FM 1382

The expansion over time of soil samples from FM 1382 and IH 45 is shown in Figures 11 and 12, respectively. Each data point on Figures 11, 12, and 13 represents the average amount of volumetric expansion calculated from four samples of the same type and location. Figures 11a and 12a represent the expansion of soil samples containing 6% hydrated lime, and Figures 11b and 12b represent samples containing no lime. From Figure 11a, it is evident that the sample marked FM 1382 Sample No. 7 which contained 6% lime, expanded more than any of the other samples. This sample also expanded the most of all the samples containing no lime (Figure 11b). Apart from showing the greatest expansion upon lime stabilization, the sample marked FM 1382 Sample No. 7 had the highest amount of sulfates (0.8% with a 1:0.5 soil:water ratio). From Figure 12a, it is evident that all samples from IH 45 responded well to lime stabilization, and the amount of expansion was between 0 and 2%. These same samples from IH 45 expanded

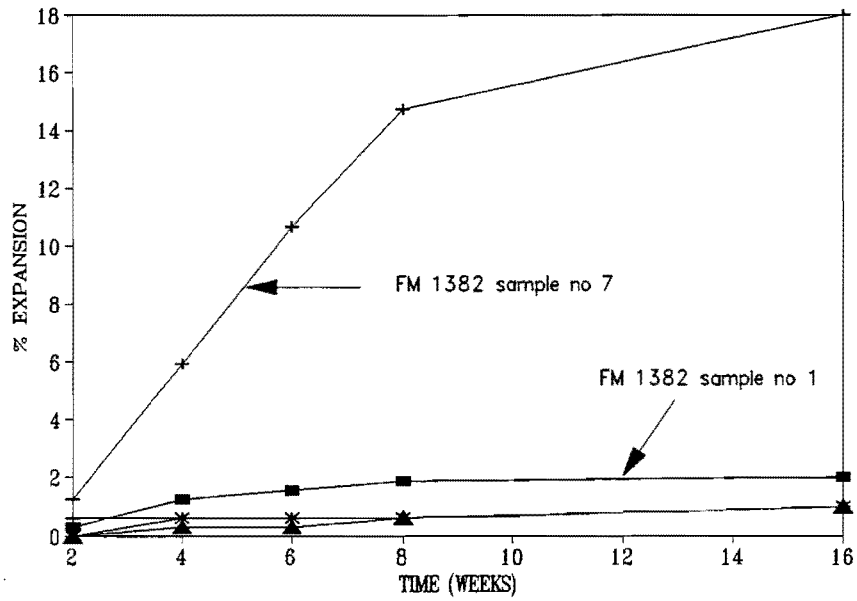

Figure 11a. Expansion of Soil Samples from FM 1382 Containing 6% Lime.

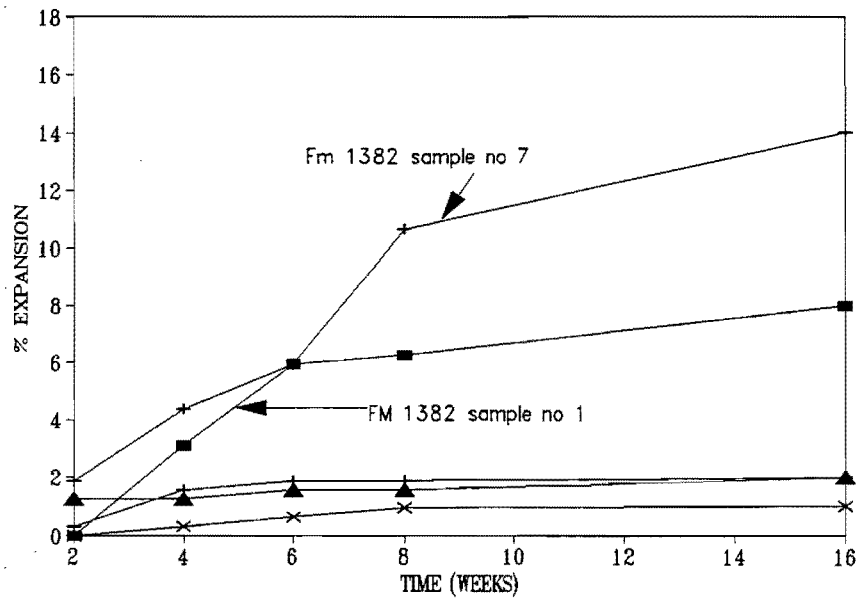

Figure 11b. Expansion of Soil Samples from FM 1382 Containing No Lime.

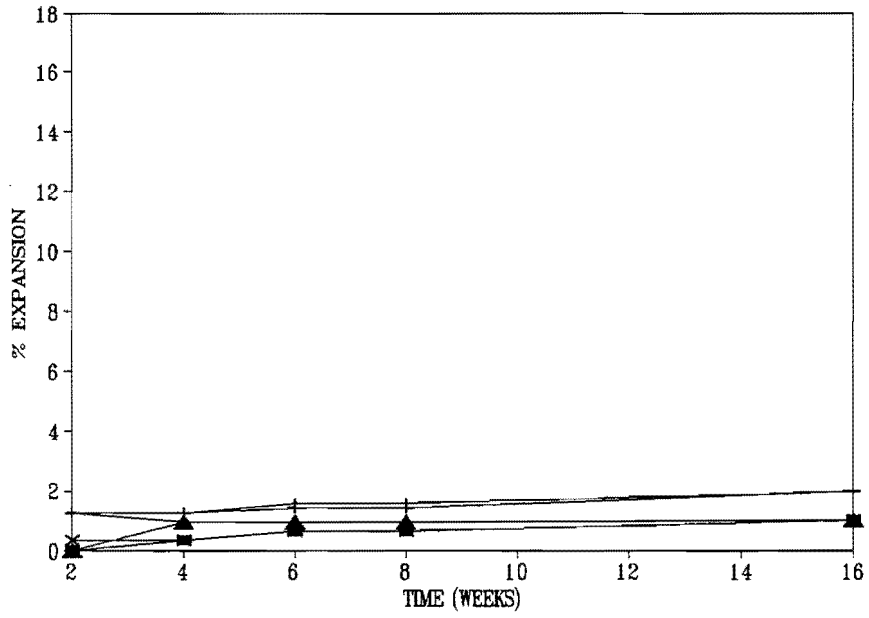

Figure 12a. Expansion of Soil Samples from IH 45 Containing 6% Lime.

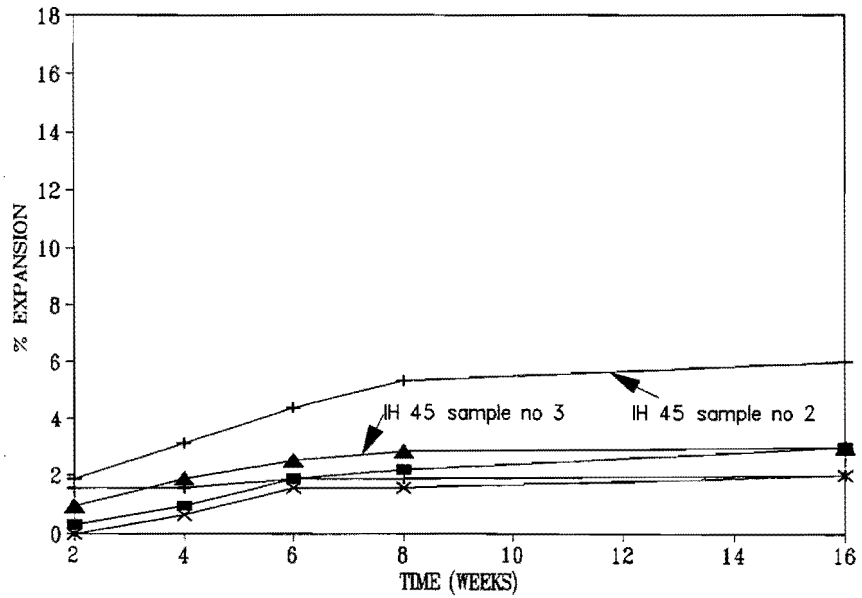

Figure 12b. Expansion of Soil Samples from IH 45 Containing No Lime.

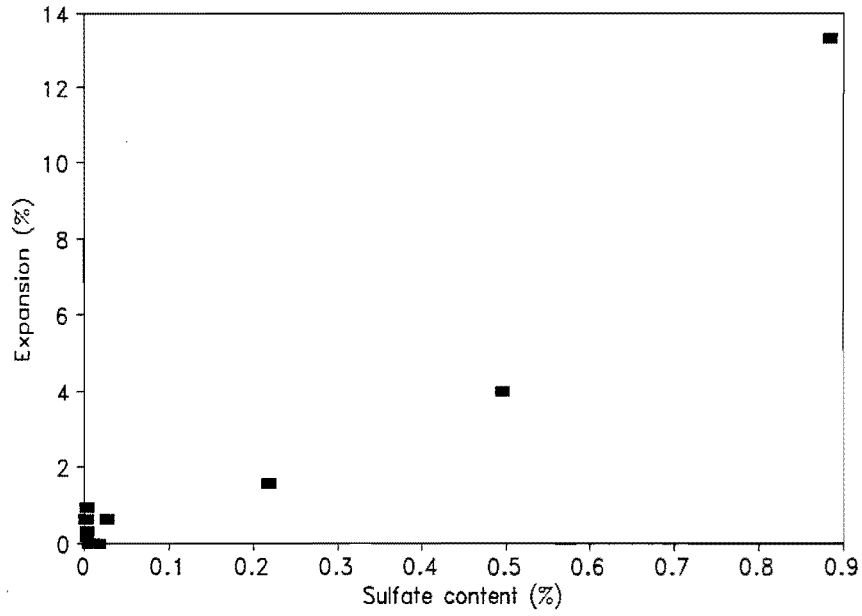

Figure 13a. Expansion of Soil Samples Containing 6% Lime vs. Sulfate Content.

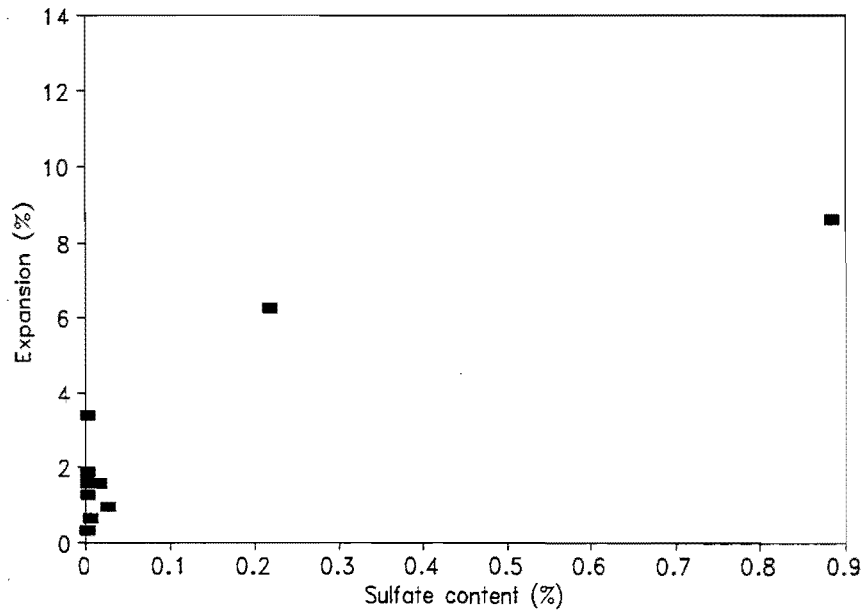

Figure 13b. Expansion of Soil Samples Containing No Lime vs. Sulfate Content.

between 2 and 6% when not lime stabilized. None of these samples contained significant amounts of sulfates.

Figures 13a and b show the relation between the expansion of the samples and the natural sulfate content of the soil samples containing 6% lime and soil samples containing no lime. This figure shows that soil samples containing higher amounts of sulfates experienced greater expansion. Although it is evident from Figures 13a and b that expansion increases with increasing sulfate content, a linear regression was performed in order to test whether a flat line could adequately describe the data. If a flat line could be fitted better than a sloping line, this would indicate that, statistically, there is no relationship between the amount of expansion and the sulfate content of the samples. The hypothesis that a flat line fit is adequate for this data was rejected at a 99% confidence level (19). This indicates that there is a definite statistical relation between the natural sulfate content of soils and the amount of expansion that occurs after lime stabilization.

Figure 14 is a photograph of the expansion of samples that do not contain lime. The sample on the left contains less than 0.2% sulfates, and the sample on the right contains 0.8% sulfates. The sample with the highest sulfate content showed the greatest expansion.

Figure 15 shows 3 samples that were stabilized with lime. The two samples on the left expanded approximately 14% and contained 0.8% sulfates, while the sample on the right is still its original size and contained less than 0.2% sulfates. Once again, the samples with the highest sulfate content showed the greatest expansion.

Figure 16 shows 2 samples which both contain 0.8% sulfates. One sample was stabilized with 6% lime, and the other contains no lime. The sample containing lime expanded 6% more than the sample that was not stabilized with lime.



Figure 14. Expansion of Samples Containing No Lime. Sample on Left Contains Less than 0.2% Sulfates and Sample on Right 0.8% Sulfates.



Figure 15. Samples Containing 6% Lime. The Two Samples on the Left Contain 0.8% Sulfates and Expanded 18%. The Sample on the Right Contain Less than 0.2% Sulfates and is Still Close to Original Size.



Figure 16. Two Soil Samples with 0.8% Sulfates. Sample on the Left Contains 6% Lime and Expanded 6% More than the Sample on the Right Which Contains No Lime.

RESULTS OF EXPANSION TESTS PERFORMED ON CLAY SOIL SAMPLES

As described in Chapter 2, ten samples of each clay soil were prepared with different amounts of sulfates and lime. Figures 17a to c show the expansions of a Beaumont clay, an Eddy clay, and a Houston black clay, with time. This chapter presents only the results of the soil samples that contained no added sulfates. The addition of sulfates had no apparent effect on the expansion of the samples both with and without lime stabilization. The samples which contained added sulfates behaved in much the same way as the samples without added sulfates.

The kaolinitic clay samples expanded so drastically within the first week that the samples completely came apart and further expansion on the samples could, therefore, not be measured. Figure 17d is a photograph of the kaolinitic samples after one week. The kaolinitic clay contained the highest percentage of natural sulfates (0.06% with a 1:2 soil:water ratio) of the four clay samples.

The Beaumont clay contained the second highest percentage of sulfates (0.01% with a 1:2 soil:water ratio). The means (Figure 17a) were compared with a two-sample t-test (19), and all but the first two measurements were found not to be significantly different with a 95% confidence level. This indicates that there is no significant difference in the amount of expansion between the lime stabilized and un-stabilized samples. The ineffectiveness of the lime stabilization could be due to the relatively high natural sulfate content of the Beaumont clay.

The other two clay soils, the Eddy clay and the Houston black clay, contain negligible amounts of natural sulfates and, in this case, the samples containing 6% lime expanded less than the samples containing no lime. In the case of the Houston black clay, the samples containing no lime showed much greater expansion than the stabilized samples, especially between the sixth and the twelfth week.

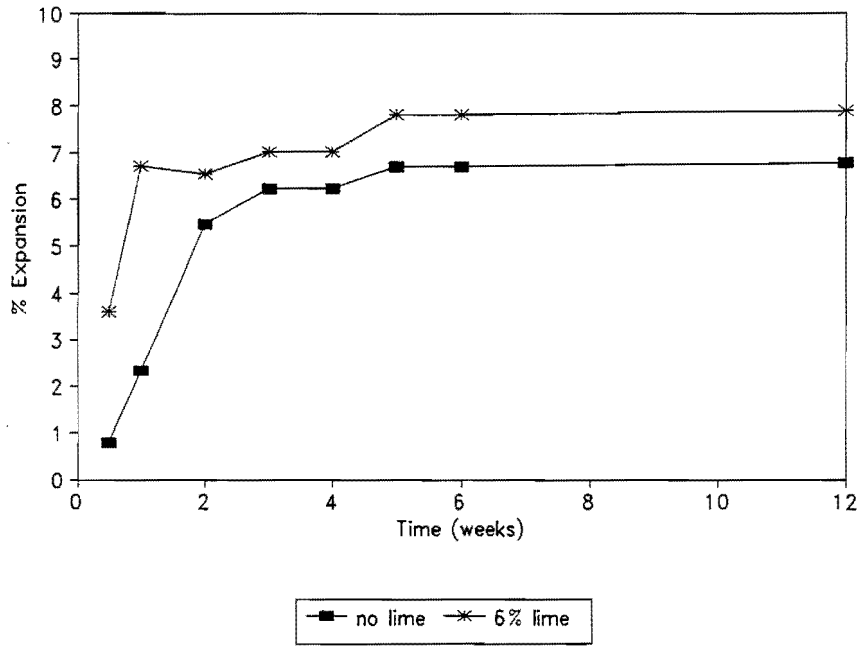

Figure 17a. Expansion of Beaumont Clay Samples vs. Time.

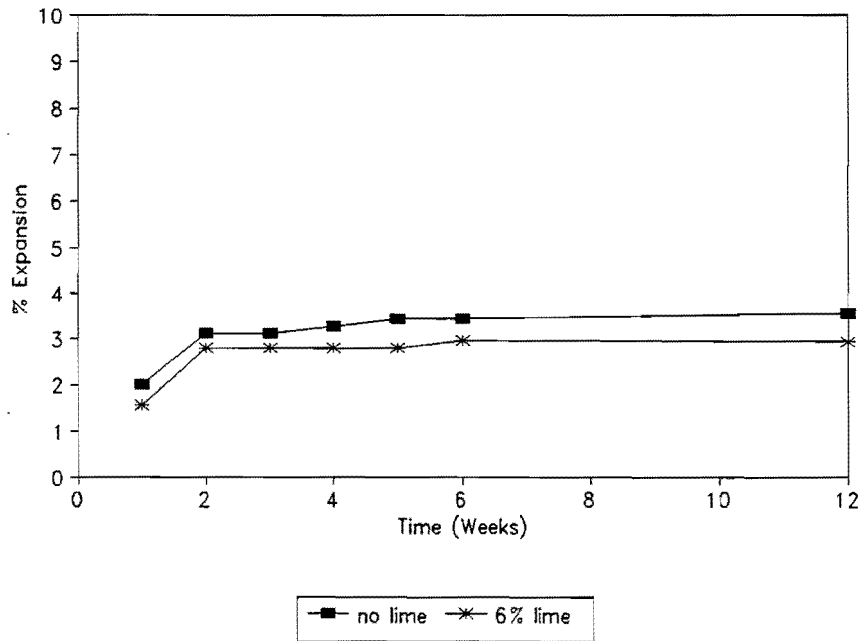

Figure 17b. Expansion of Eddy Clay Samples vs. Time.

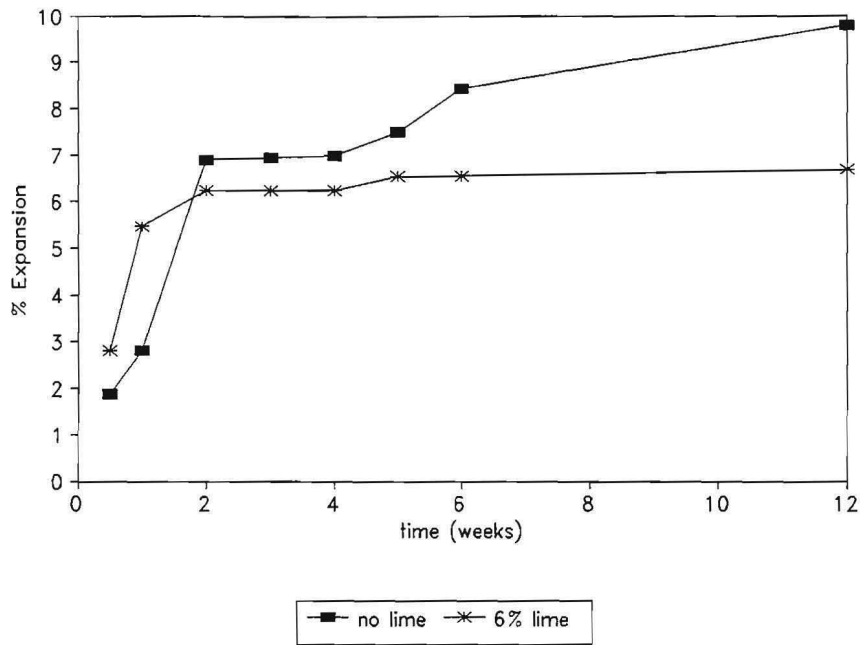

Figure 17c. Expansion of Houston Black Clay Samples vs. Time.



Figure 17d. Expansion of Kaolinitic Samples.

CONCLUSIONS

- From Figure 13, it is evident that the sulfate content is related to the amount of expansion encountered in soil samples from FM 1382 and IH 45. As the sulfate content increases, the amount of expansion increases. This expansion could be due to the reaction between the calcium in the lime and the sulfates in the soil which form ettringite, an expandable mineral described in Chapter 1.
- Unstabilized soils which contained relatively high amounts of sulfates ($>0.2\%$ with 1:0.5 soil water ratio) showed greater expansions than un-stabilized soils containing small amounts of sulfates ($<0.2\%$ with 1:0.5 soil water ratio) (Figure 14).
- In some cases, soil samples with high sulfate contents that were stabilized with lime expanded more than samples with the same sulfate content that were not stabilized with lime, as can be seen in Figure 16. For this reason, it might be advantageous not to stabilize sulfate bearing soils at all, or to use an alternative stabilizer rather than to stabilize these soils with lime.
- The addition of sulfates has no effect on the expansion of the soil samples, regardless of whether the samples contained lime or not. It seems like ettringites do not form in cases where the natural sulfate content is low, even though up to 1% sulfates were added to the soil.
- Of the four clay samples under investigation, the samples with the highest sulfate content (Kaolinite, Figure 17d) expanded most. Samples that did not contain natural sulfates expanded less if lime stabilized than the unstabilized samples.

CHAPTER 5

RESULTS FROM ELECTRICAL CONDUCTIVITY MEASUREMENTS

INTRODUCTION

This chapter presents the results obtained from electrical conductivity measurements performed by the standard EPA procedure and a permittivity probe (as outlined in Chapter 2). In each case, the electrical conductivity is related to the sulfate content of the soil and also to the total amount of soluble salts for a known soil:water ratio. Soluble salts are those salts that dissolve when a known amount of water is added to the soil. If more water is added to the soil, more of the salt in the soil dissolves in the water. For this reason, the soil:water ratio is an important parameter that should always be reported when salt concentrations are reported. The soil:water ratio is determined by proportions of the weight of the soil and the water.

The sulfate content, as measured by the EPA procedure for the determination of total soluble sulfates, is presented for each soil under investigation. Electrical conductivity measurements were taken on the four clay soil samples and also soil samples from FM 1382 and IH 45. The sulfate content of the soils, as determined by the EPA procedure, is presented first. After that, the electrical conductivity for different sulfate contents is presented.

RESULTS FROM SOLUBLE SULFATE DETERMINATION

Tables 4a and b contain the results from the determination of soluble sulfates for the different soil samples. The total amount of sulfates in soils from FM 1382 and IH 45 cannot be compared to the amount of sulfates in the four clay soils since the sulfate determination was performed at different times and was not performed at the same soil:water ratio. As a consequence of the greater water content used with the four clay soils, the amount of soluble salts in the pore water is expected to be greater by an undetermined amount than in the pore water in the soils from IH 45 and FM 1382. As previously mentioned, gypsum is one of the least soluble salts, and the amount of gypsum detected in soils is highly dependent on the soil:water ratio.

Table 4a. Amount of Soluble Sulfates in the Four Clay Soil Samples.

Material Type	Amount of Soluble Sulfates (meq/l) 1:2 soil:water ratio
Eddy Clay	0.4
Houston Black Clay	1.1
Beaumont Clay	1.2
Kaolinite	12

Table 4b. Amount of Soluble Sulfates in the Soil Samples Obtained from FM 1382 and IH 45.

Location	Sample No.	Amount of Soluble Sulfates (meq/l) (1:2 soil:water ratio)
IH 45	1	0.7
	2	0.5
	3	0.5
	4	0.7
	5	0.5
	6	1.3
	7	0.5
	8	0.6
	9	0.5
	10	2.1
FM 1382	1	45.5
	2	3.5
	3	0.4
	4	0.7
	5	5.6
	6	103.4
	7	184.

There is a general tendency to believe that the light colored clays, like the kaolinitic clay and the Eddy clay from FM 1382 Soil Sample No 7, have the highest amount of soluble sulfates. However, this is not always true since the Eddy clay which was used as one of the standard clay soil samples is light colored but has a low sulfate content of 0.4 meq/l.

RESULTS FROM ELECTRICAL CONDUCTIVITY MEASUREMENTS ON SOIL SAMPLES OBTAINED FROM IH 45 AND FM 1382

The results from the electrical conductivity for these samples were obtained only by the EPA procedure with a 1:20 soil:water ratio. Figure 18 shows how the electrical conductivity increases as the sulfate content of the soils increases. In this case the electrical conductivity is related to the natural sulfate content in the soils since no sulfates were added to these samples. The hypothesis that a flat line fits the data from Figure 18 adequately was rejected with a 99% level of confidence. This indicates that there is a statistical relation between the sulfate content and the electrical conductivity of the soils. A regression analysis was performed to obtain an equation that describes the relation between electrical conductivity and the sulfate content in the soil (19). The equation that fit the data best with a correlation coefficient of 0.9985 is:

$$EC = \exp(0.799 + 0.014 \times \text{Sulfate Content})$$

where EC is the electrical conductivity in mS/cm. The regression line that fits the data best is shown in Figure 19.

RESULTS FROM ELECTRICAL CONDUCTIVITY MEASUREMENTS ON FOUR CLAY SOILS

Electrical conductivity measurements for the Eddy, Beaumont, Houston black, and Kaolinitic clay for both methods, EPA procedure and permittivity probe, are presented in Figures 20a to d. For the Eddy, Houston black, and Kaolinitic clay, the electrical conductivity at a sulfate level of 1% reaches a value between 5 and 8 mS/cm. The electrical conductivity of the Beaumont clay does not seem to increase as

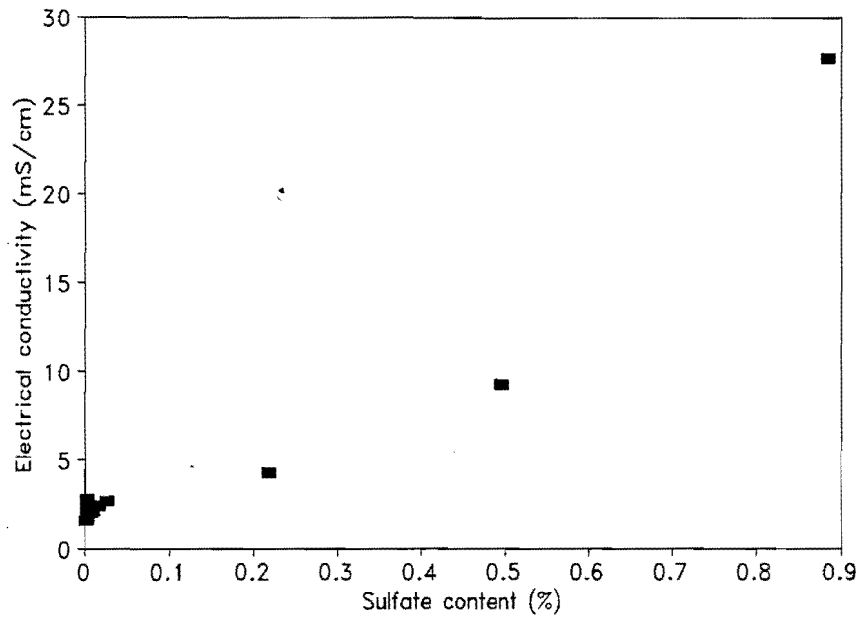

Figure 18. Relation Between Electrical Conductivity and Natural Sulfate Content of Soil Samples from FM 1382 and IH 45.

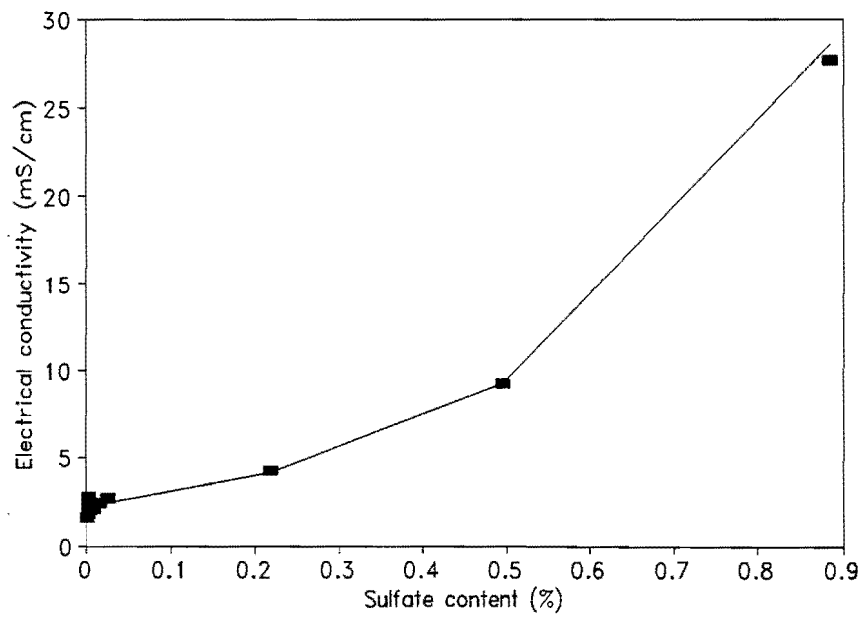

Figure 19. Regression Line for Electrical Conductivity and Sulfate Content.

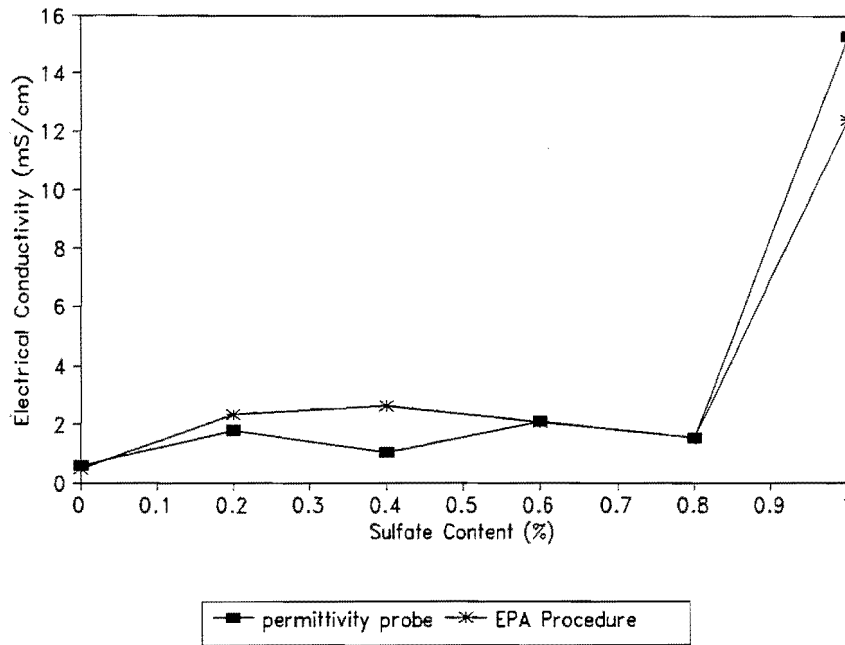

Figure 20a. Electrical Conductivity vs. Sulfate Content of a Beaumont Clay.

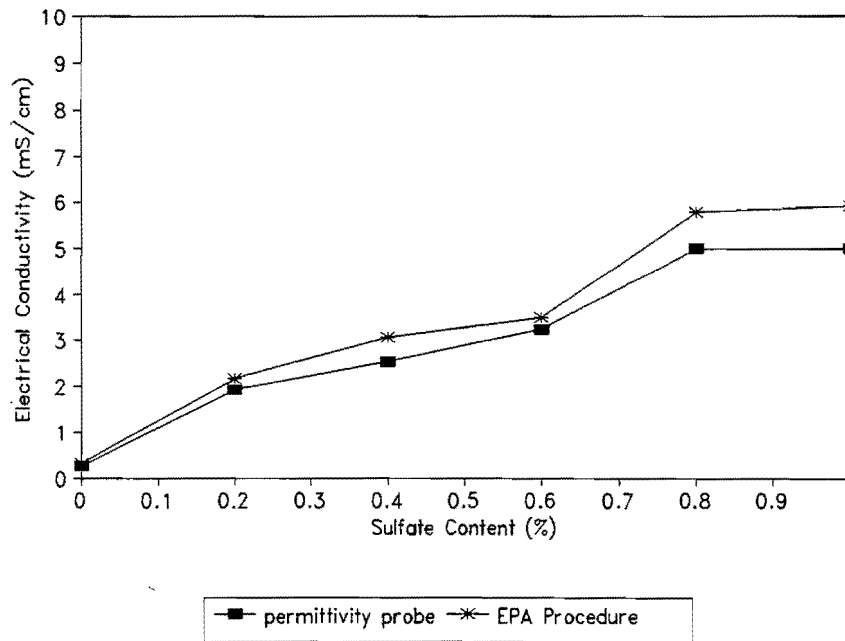

Figure 20b. Electrical Conductivity vs. Sulfate Content of an Eddy Clay.

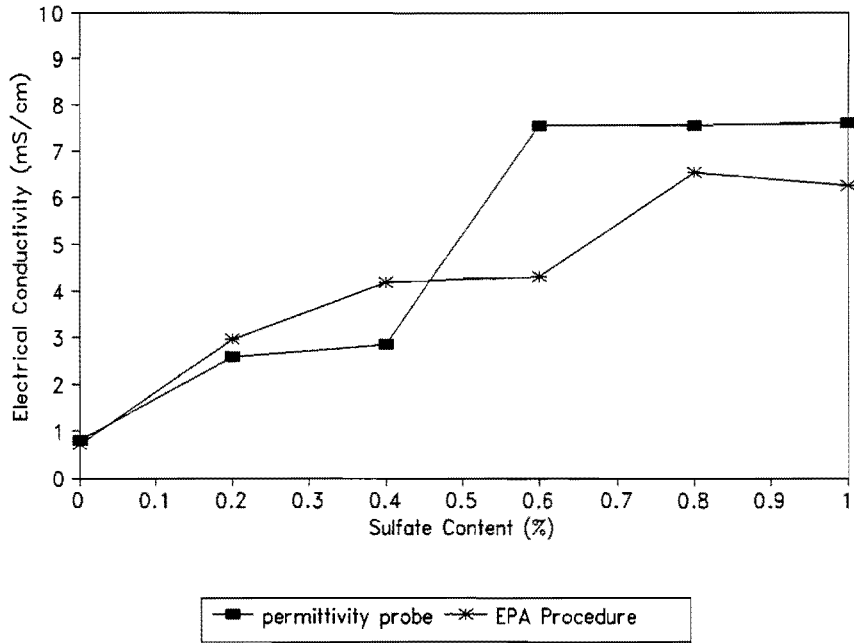

Figure 20c. Electrical Conductivity vs. Sulfate Content of a Houston Black Clay.

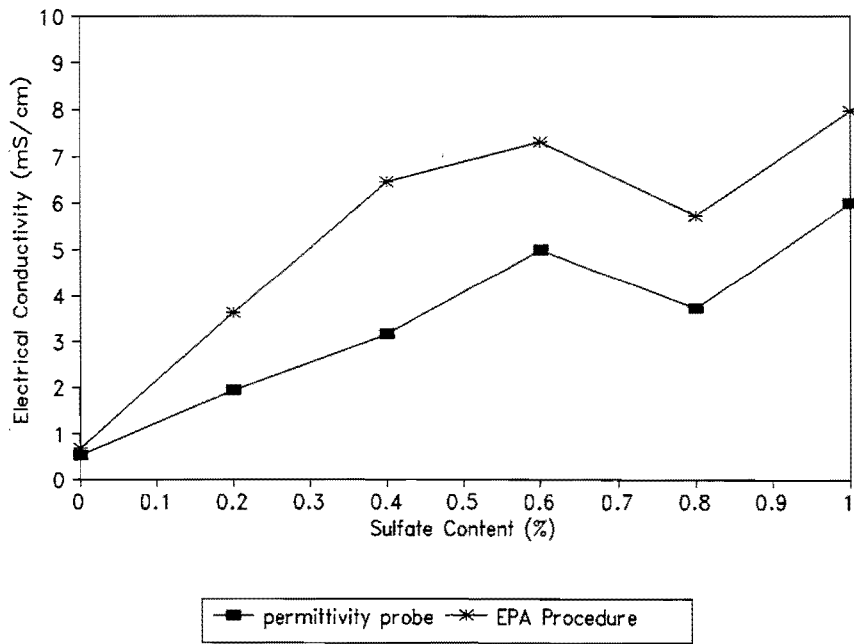

Figure 20d. Electrical Conductivity vs. Sulfate Content of Kaolinite.

much with an increase in sulfate content, but shows a sudden increase to about 13 mS/cm between sulfate contents of 0.8% and 1%.

Electrical conductivity measurements with two different methods, the permittivity probe and the EPA procedure, seem to correspond quite well to each other. In most cases, the results obtained from the EPA procedure are slightly higher than those obtained by the permittivity probe. A statistical t-test showed that the difference between the electrical conductivity values determined by the EPA procedure and the permittivity probe are insignificant. The test was performed at a 95% level of confidence.

The effect that salts other than sulfates had on the electrical conductivity was also investigated. Figure 20e shows how addition of calcium chloride affected the electrical conductivity. As the calcium chloride decreased from 1% to 0% and the sulfate content increased from 0% to 1%, the electrical conductivity decreased from about 14 mS/cm to about 7 mS/cm. This indicates that the electrical conductivity for the calcium chloride is generally higher than for sulfates. Even though the total salt concentration stayed constant at 1%, the electrical conductivity decreased because of the lower maximum electrical conductivity of sulfates compared to calcium chloride. All the electrical conductivity values for different sulfate contents for the four clay soils were superimposed in one graph, shown in Figure 21. A regression was performed in order to obtain an equation that explains the relation between electrical conductivity and sulfate content in soils. Although more complex equations were considered, a straight line seemed to have the best fit. The relation between electrical conductivity and sulfate content can be represented by the following equation:

$$y = mx + c$$

where

y = electrical conductivity (mS/cm)

x = sulfate content (%)

m = Slope of line (5.331)

c = Intercept (0.679)

This equation yielded a coefficient of determination of 0.61.

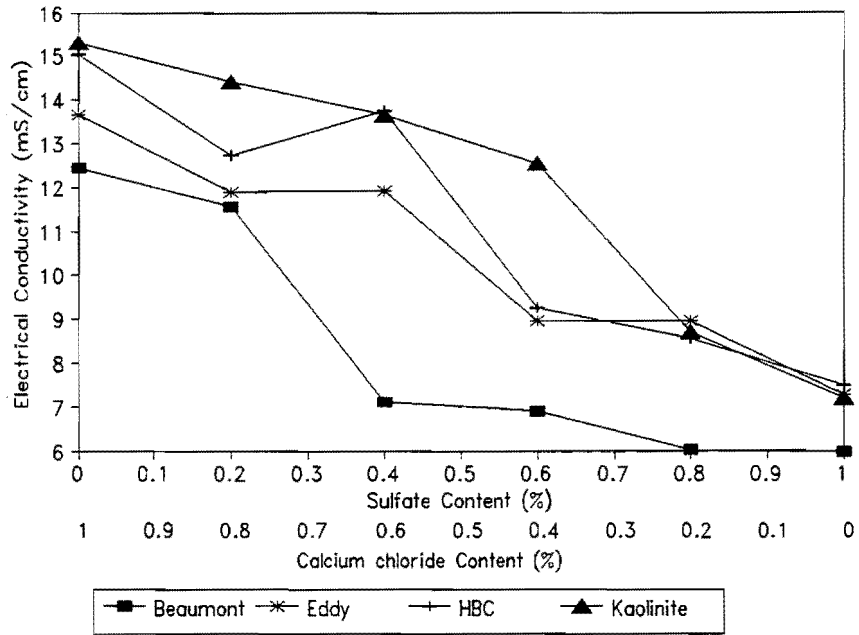

Figure 20e. Electrical Conductivity vs. Chloride and Sulfate Content.

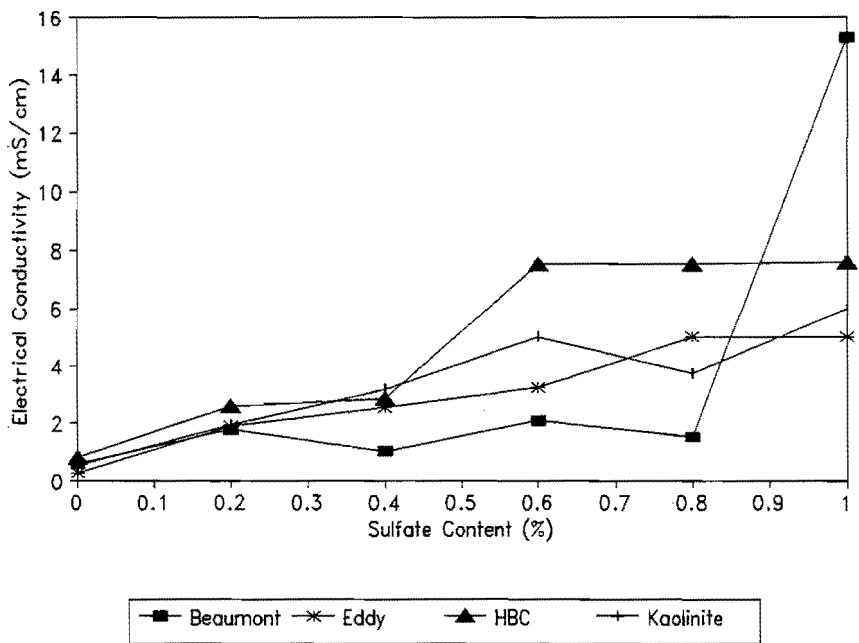

Figure 21. Electrical Conductivity Values of the Four Clay Soils vs. Sulfate Content.

The reason for determining a regression equation is to be able to predict the most probable value of electrical conductivity at a given sulfate content for different kinds of soil. Therefore, it is reasonable to determine an average electrical conductivity at each sulfate content for the different soils. This average value of electrical conductivity is then used to determine a regression equation with an improved fit. This can be clearly seen by comparing Figures 21 and 22 where Figure 21 presents all the electrical conductivity data points for different soils, and Figure 22 presents only the mean values of electrical conductivity for different soils. Table 5 presents the means calculated from the four values of electrical conductivity for the four different soils at different sulfate contents. The corresponding standard variations are also listed in this table.

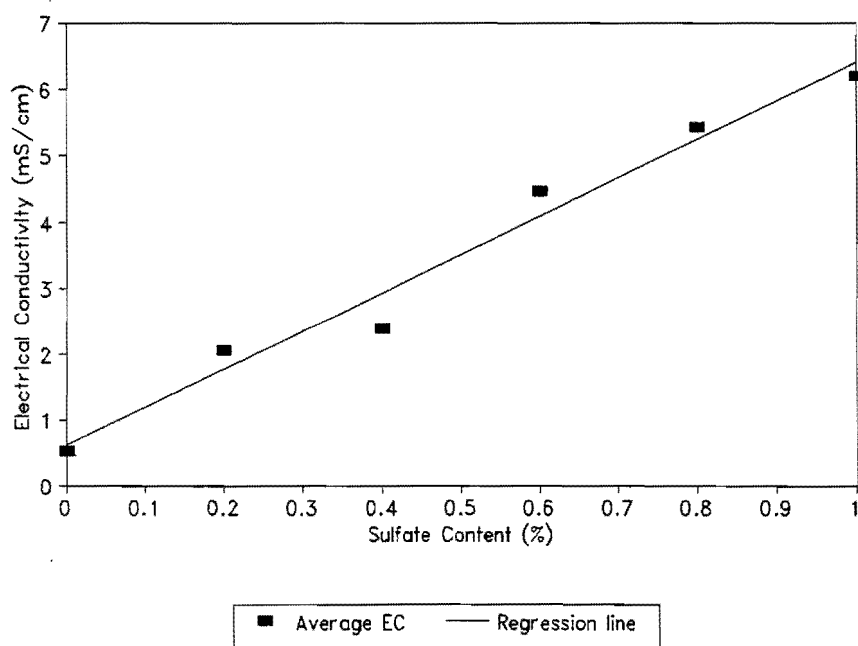

Figure 22. Regression Line Fitted through Mean Values of Electrical Conductivity for Different Sulfate Contents.

Table 5. Mean Electrical Conductivity Value at Different Sulfate Contents, with Standard Deviation.

Sulfate content	Mean electrical conductivity	Standard deviation
0	0.538	0.222
0.2	2.063	0.362
0.4	2.392	0.950
0.6	4.468	2.371
0.8	5.427	1.933
1.0	6.204	1.310

The regression line that fit this data best was a straight line with the equation:

$$y = mx + c$$

where

y = Electrical conductivity (mS/cm)

x = Sulfate content (%)

m = Slope of line (5.785)

c = Intercept (0.623)

This line has a coefficient of determination of 0.98. The constant in this equation that was fitted through the average values is very similar to the constants in the equation that were fitted through all of the data points. The average values with the regression line are shown in Figure 22.

In Figure 4 from Chapter 1, the concentration of a single-salt solution is related to electrical conductivity. Figure 4 relates electrical conductivity of a calcium sulfate (gypsum) to salt concentration of 1 gram of salt for every 100 grams of water. The relationship is expressed by a straight line. To be able to make a comparison between the electrical conductivity of this single-salt solution of gypsum and the electrical

conductivity of a soil solution containing different percentages of gypsum, it is necessary to make sure that the salt:water ratio in each case is the same. In the case of the soil solution with sulfates, a 1:2 soil:water ratio was used with the addition of sulfates varying from 0 to 1%, according to the weight of the soil. Using a 1:2 soil:water ratio with 100 grams of water suggests that the weight of the soil is 50 grams, and one percent sulfates added to 50 grams of soil is 0.5 grams. Therefore, 0.5 grams of sulfates in 100 grams of water is equivalent to 1% sulfates. In the same way, it can be calculated that 0.8% of sulfates correspond to 0.4 grams of salt in 100 g of water, 0.6% to 0.3 grams, 0.4% to 0.2 grams, and 0.2% to 0.1 gram. By entering Figure 4 in Chapter 1 at the calculated salt concentrations, the corresponding electrical conductivity values for a single-salt solution can be obtained. However, to obtain these values it is assumed that the line representing calcium sulfate can be extended linearly. The values are tabulated in Table 6. Electrical conductivity values corresponding to gypsum content in a soil solution, as calculated with the regression equation previously stated, are also presented in Table 6.

Table 6. Comparison between Electrical Conductivity Measurements of Single-Salt Solution and Soil Solutions at the Same Sulfate Concentration.

Sulfate Concentration (%)	Electrical Conductivity of Single Salt Solution (mS/cm)	Electrical Conductivity of Soil Solution (mS/cm)
0	0	0.62 ± 0.24
0.2	1	1.77 ± 0.39
0.4	2	2.93 ± 1.01
0.6	3	4.09 ± 2.53
0.8	4	5.25 ± 2.06
1.0	5	6.40 ± 1.40

From this table, it can be seen that the regression equation for soil solutions containing sulfates yields values that are in close correspondence with the values obtained from electrical conductivity measurements on single-salt solutions. The electrical conductivity seems to be slightly higher in the case of the soil solution when compared to measurements on single-salt solutions. The electrical conductivity seems to be slightly higher in the case of the soil solution when compared to the electrical conductivity obtained from the single-salt solution. This may be due to the fact that there are other salts and impurities present in the soil solution which increase the conductivity potential of the solution. A 90% confidence interval was added to the values obtained by using the regression equation. For the lower sulfate contents, the confidence interval is small; however, for the higher sulfate concentrations, the interval tends to get quite large.

WATER CONTENT OF THE IN SITU SOIL

The regression models developed in this chapter relate electrical conductivity to sulfate content and are dependent on the soil:water ratio of the paste used to measure electrical conductivity. The two regression models were developed for 1:2 and 1:20 soil:water ratios, respectively. Since sulfates are one of the most insoluble salts, the soil:water ratio has a great influence on the amount of sulfates measured in a soil paste. The relationships developed in this chapter only hold true for that specific soil:water ratio of the paste on which the electrical conductivity was reported. In each of the experiments performed, the soil were oven dried before water was added by weight. Since this electrical conductivity determination is proposed to be performed in situ in the field, it would not be possible to perform the experiment on oven dried soil. It is, therefore, necessary to know the in situ water content of the soil, and take that into consideration when water is added to the soil to obtain a paste with an exact soil:water ratio on which electrical conductivity measurements are to be performed.

The permittivity probe that was used to measure electrical conductivity on the four clay soil samples also has the facility to measure the dielectric constant of the in situ soil. The dielectric constant of soil is related to the volumetric water content in the soil (7). The dielectric constant is also a function of the amount of compaction of the soil.

For this reason, it is necessary to perform a calibration for each geologic formation on which volumetric water content is to be determined. A calibration curve could be constructed by measuring dielectric constants of soil samples with known moisture contents ranging over typical field moisture values. This calibration procedure should be repeated for each major soil type on which electrical conductivity measurements are to be performed. The calibration curve could then be used to obtain an estimate for the volumetric water content, and this estimate could be divided by the specific gravity of the soil to obtain gravimetric water content.

CONCLUSIONS

- Electrical conductivity relates to the sulfate content in soils, regardless whether the sulfates were added to the soil or whether the sulfates occur naturally in the soil.
- There is no statistical difference between the electrical conductivity measurements performed by the EPA procedure and the permittivity probe. Therefore, the permittivity probe could be successfully used to perform field calculations for electrical conductivity.
- Other salts have an effect on electrical conductivity. For this reason, it is not possible to determine whether an electrical conductivity measurement is only due to sulfates in the soil. However, since sulfates are the least soluble of all salts, it is probable that other salts could have been washed down to a depth of maximum water penetration which leaves only the sulfates in the top horizons. In this investigation, high electrical conductivity values have in each case been associated with high sulfate contents, and high contents of other salts have not been encountered.
- The mean values for electrical conductivity at different sulfate concentrations were determined, and a regression equation was obtained. A straight line fit the data best with a coefficient of determination of 0.98.
- Electrical conductivity measurements on a soil solution compared well with electrical conductivity measurements on a single-salt solution with gypsum.

- Confidence intervals for higher sulfate concentrations seem to be larger than the confidence intervals obtained for low sulfate concentrations. However, even when incorporating the confidence intervals, the regression equation still gives a reasonable indication of the sulfate content in the soil.
- The sulfate content and electrical conductivity of the soil is highly dependent on the soil:water ratio of the paste used to measure these quantities. The permittivity probe should be used to measure the dielectric constant of the in situ soil which can be related to moisture content. When water is then added to soil, the in situ water content of the soil should be taken into account.

CHAPTER 6

RESULTS OF SUPPLEMENTARY TESTS

INTRODUCTION

In this chapter, the results of all the supplementary tests will be presented. These tests include CEC determination and dielectric constant determination.

CEC is an inherent soil property that differs with each soil type. CEC gives an estimate of the amount of exchangeable cations on the particle surfaces and also relates to the total amount of surface area available. This chapter presents the results of the CEC for all the soils under investigation.

Dielectric constant is an electrical property that has been related to the moisture content of in situ soil (7). This unit-less constant is reported at different frequencies and is presented in this chapter for each soil under investigation.

Neither the CEC nor the dielectric constant has any direct relation to the sulfate swell problem. However, in Chapter 7 an attempt will be made to establish a relationship between the amount of expansion, the sulfate concentration, electrical conductivity, CEC, and the dielectric constant. The latter two soil properties could assist in classification of the soil type with relation to sulfate content and expansion.

Apart from these tests the natural pH of the clay soils from IH 45 and FM 1382 has also been tested. The relation between pH and the amount of expansion is discussed in Appendix B.

RESULTS FROM CATION EXCHANGE CAPACITY DETERMINATION

Tables 7a and b contain the CEC's for the different soils under investigation. The CEC values were measured using the atomic absorption method as described in EPA method No 9081 (17).

The CEC values for these soils vary between approximately 0 meq/100 g and 40 meq/100 g. For the standard clay soil samples, it is interesting to note that the CECs for the light colored soils are low (<10 meq/100g) while the CECs for the dark colored soils are relatively high (between 30 and 40 meq/100g). However, soil

Table 7a. Cation Exchange Capacities for the Four Clay Soil Samples.

Material Type	CEC (meq/100g)
Eddy Clay	8.5
Houston Black Clay	36.5
Beaumont Clay	38.2
Kaolinite	3.2

Table 7b. Cation Exchange Capacities for Soil from FM 1382 and IH 45.

Samples Location	Samples No.	CEC (meq/100g)
IH 45	1	26.6
	2	30.4
	3	31.2
	4	9.2
	5	21.7
	6	16.7
	7	15.0
	8	16.3
	9	37.3
	10	31.5
FM 1382	1	14.3
	2	19.3
	3	10.6
	4	9.0
	5	35.6
	6	25.0
	7	35.6

Sample No. 7 from FM 1382 was also an Eddy clay (light colored) but has a high CEC value.

RESULTS OF DIELECTRIC CONSTANT MEASUREMENTS

Dielectric constant values were measured only for the four clay soil samples. Figures 23(a) through (d) show the dielectric constant values obtained for different soils at a range of frequencies. The different lines on each figure represent the amount of added sulfates varying from 0 to 1%. Except for the kaolinitic clay, the differences between these lines are within the limits of measurement error, meaning that the percent added sulfate does not govern the relationship between the dielectric constant and the frequency of measurement. This is shown in Figure 24. Except for the kaolinitic clay, the data points for the other clay types are, in each case, best fitted by a flat line, which means there is no relation between the dielectric constant and the amount of added sulfates in the soil. For the kaolinitic clay, however, there seems to be a relation as the dielectric constant increases with an increase in sulfate content.

The dielectric constant at high frequencies seems to be lower for the Eddy clay than for any of the other clay samples, while the Houston black clay seems to have the highest dielectric constant at low frequencies.

The following equation gives the relation between dielectric constant, ϵ , and frequency, f , in GHz:

$$\epsilon = \epsilon_0 e^{-\alpha f}$$

where α is a constant that governs the rate of decay of dielectric constant as the frequency increases, and ϵ_0 is the maximum value for the dielectric constant. A range of maximum values can be obtained for the four different clay soils from Figures 23 (a) through (d). These values for ϵ_0 as well as values for ϵ at the corresponding frequencies were used in the above equation to obtain a range of values for α for each clay type. Table 8 shows the results of these calculations.

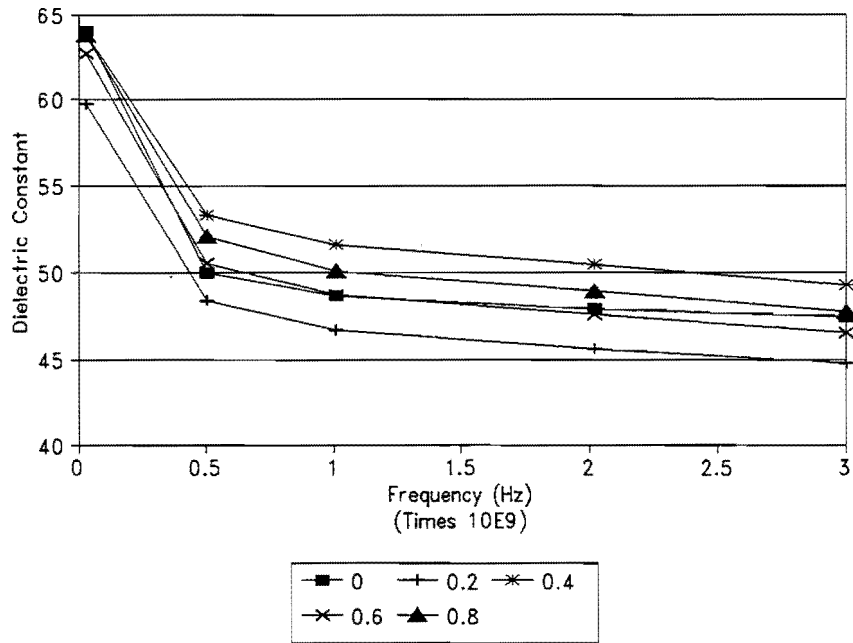

Figure 23a. Dielectric Constant vs. Frequency for an Eddy Clay.

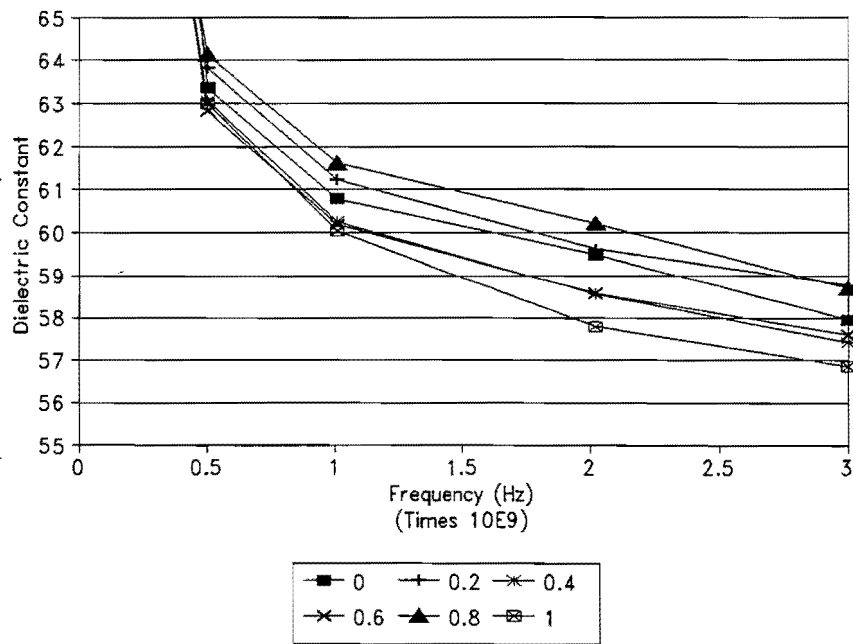

Figure 23b. Dielectric Constant vs. Frequency for a Beaumont Clay.

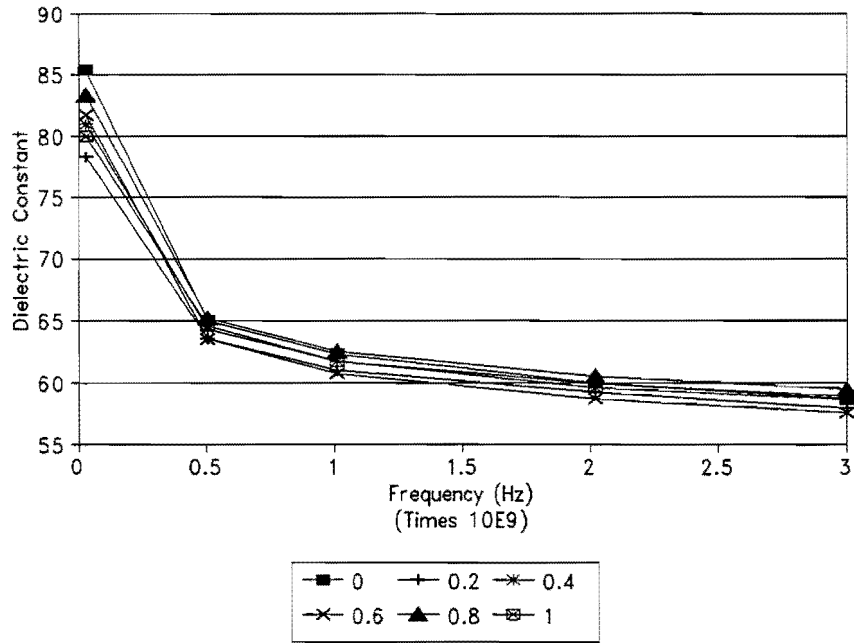

Figure 23c. Dielectric Constant vs. Frequency for a Houston Black Clay.

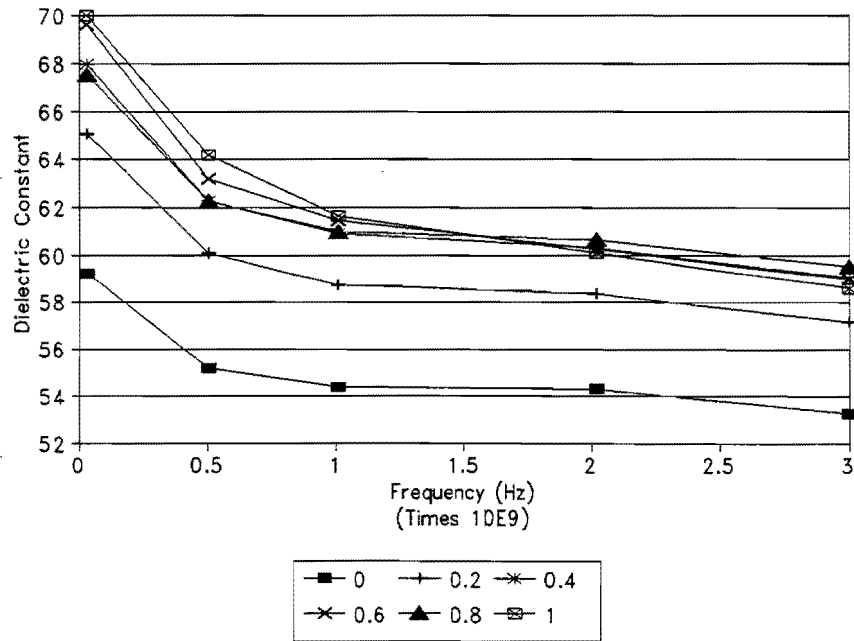

Figure 23d. Dielectric Constant vs. Frequency for a Kaolinitic Clay.

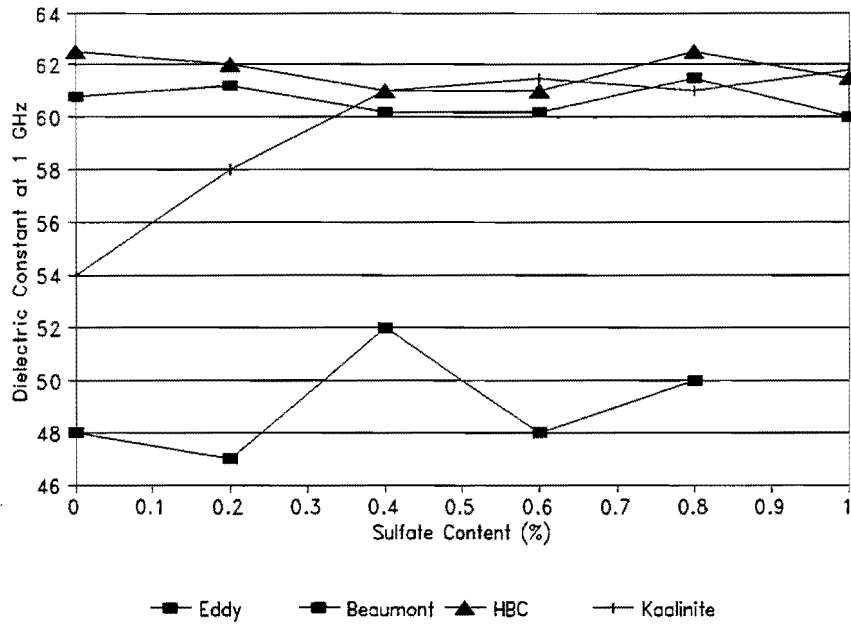

Figure 24. Relation Between the Dielectric Constant and the Amount of Added Sulfates.

Table 8. Values for α Calculated from Known Values of ϵ at Different Frequencies with Values for CEC.

Soil Type	CEC (meq/l)	ϵ_0 (GHz)	α
Eddy Clay	8.5	60 - 65	0.094 - 0.096
Beaumont Clay	38.2	64 - 65	0.036 - 0.041
Houston Black Clay	36.5	78 - 81	0.102 - 0.126
Kaolinitic Clay	3.2	59 - 70	0.049 - 0.051

The relationships between CEC vs. ϵ_0 and CEC vs. α are shown in Figures 25 and 26. In Figure 25, the range of maximum dielectric constant values for the range of added sulfate contents are plotted against the CEC for each soil type. Three of these data ranges, the HBC, the Eddy clay, and the kaolinitic clay, seem to plot within a band, as shown in Figure 25. The Beaumont clay is different from the other three and does not plot within the same band.

Figure 26 shows how the range of α -values relates to the CEC. Once again, it can be seen that the data ranges for the kaolinitic clay, the Eddy clay, and the HBC plots within a band, but the Beaumont clay once again plots on the outside of this band.

CONCLUSIONS

- The CECs for the soils under investigation varied from 0 to 40 meq/100g. The CEC values for the light colored soils seemed to be lower than that for the dark colored soil; however, this does not always hold true.
- The dielectric constant decreases with an increase in frequency for each soil type. According to Figure 24, the amount of sulfates added to each sample seemed to have no relation to the dielectric constant of that specific sample. However, it still remains to be established whether the dielectric constant has a relation to the natural sulfate content of the soil samples.
- The CEC and ϵ_0 seem to be related to each other. Data-ranges for three of the clay soils fell into a band in which the CEC values increase as ϵ_0 increases. The data-range for the Beaumont clay does not fall within this range.
- The CEC also seems to be related to ranges of α -values obtained for three of the soils under investigation. Once again, the Beaumont clay does not conform to this range.
- The Beaumont clay seems to be the exception in each of the two above mentioned cases. This phenomenon suggests a difference between the Beaumont clay and the other three clay soils. However, at this stage, the difference is still unexplained.

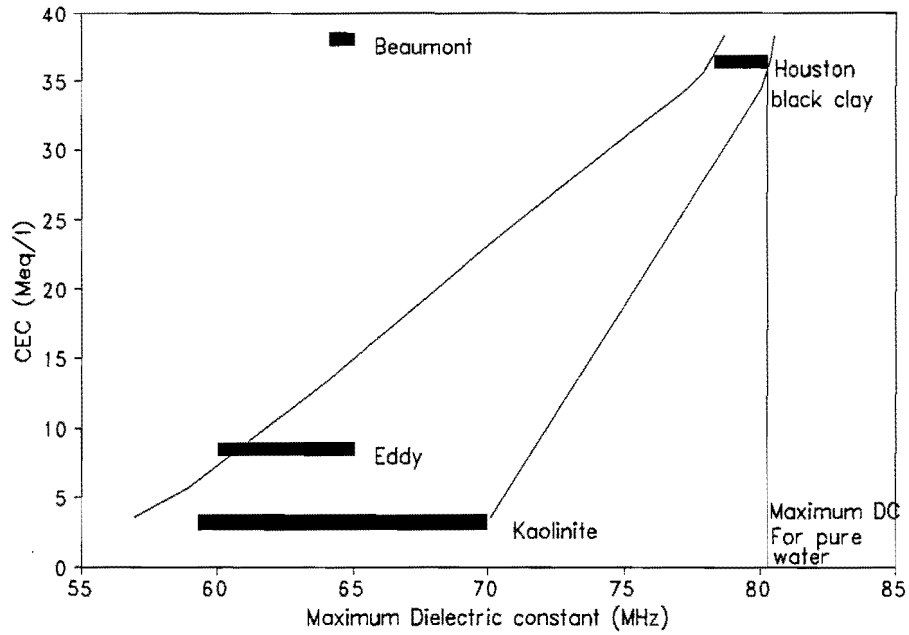

Figure 25. Relation between the CEC and the Range of ϵ_0 Values.

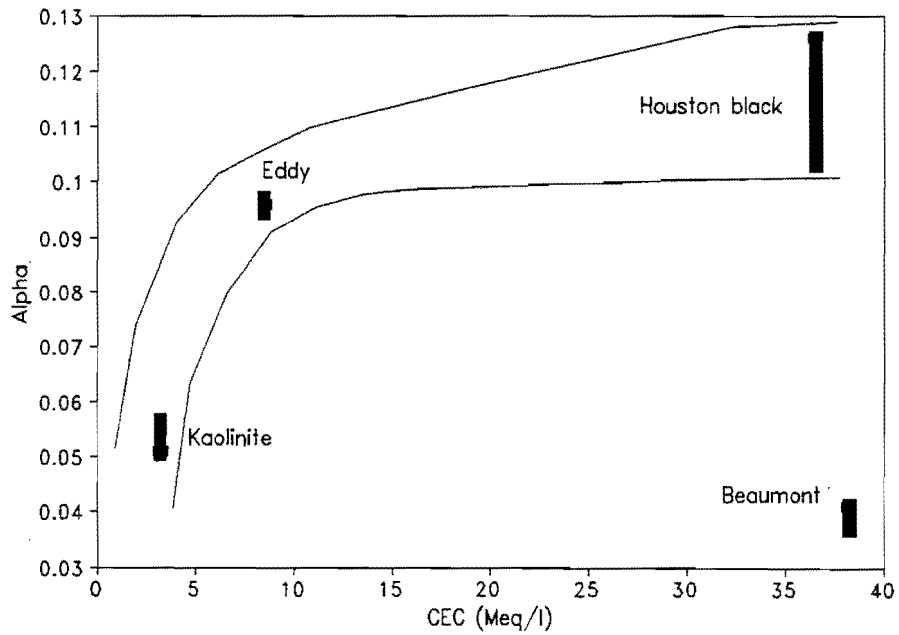

Figure 26. Relation between CEC and Range of α -Values.

CHAPTER 7

RESULTS OF LOW CALCIUM FLY-ASH STABILIZATION

INTRODUCTION

Soil often requires stabilization of some sort to enhance mechanical stability. Pozzolanicly induced long-term strength gain is achieved by mixing lime with clay soils (12). Hydrated lime is one of the most common stabilizers used to enhance subgrade strength. However, hydrated lime contains high percentages (up to 80%) of calcium, which sometimes reacts with sulfates present in the soil to form ettringites, an expandable mineral (1). For this reason, sulfate bearing soils need to be stabilized with a low calcium stabilizer to prevent ettringite formation. Low calcium fly-ashes like Sandow, Montecello, and Big Brown have been used to investigate their effects on sulfate bearing clay soils. The results of expansion tests that were performed with these low calcium fly-ashes are presented in this chapter. Expansion tests were performed on the four clay soil samples as well as Sample No. 7 from FM 1382, which contained the highest amount of natural sulfates and expanded up to 18% upon lime stabilization (see Figure 13a).

RESULTS OF LOW CALCIUM FLY-ASH STABILIZATION ON FOUR CLAY SOILS

Each of the clay soils was stabilized with each of the low calcium fly-ashes and subjected to expansion tests. For each clay, an un-stabilized sample and a sample stabilized with hydrated lime were also subjected to expansion tests. These samples served as control samples with which the samples stabilized with low calcium fly-ash could be compared.

The expansion of Eddy clay samples stabilized with low calcium fly-ashes is shown in Figure 27(a). The sulfate concentration of the Eddy clay is 0.4 meq/l (1:2 soil:water ratio), which is relatively low and probably will not induce sulfate related heave. From Figure 27(a), it can be seen that the most effective stabilizer seems to be hydrated lime. The low calcium fly-ash used to stabilize this clay performed better than the sample that contained no stabilizer.

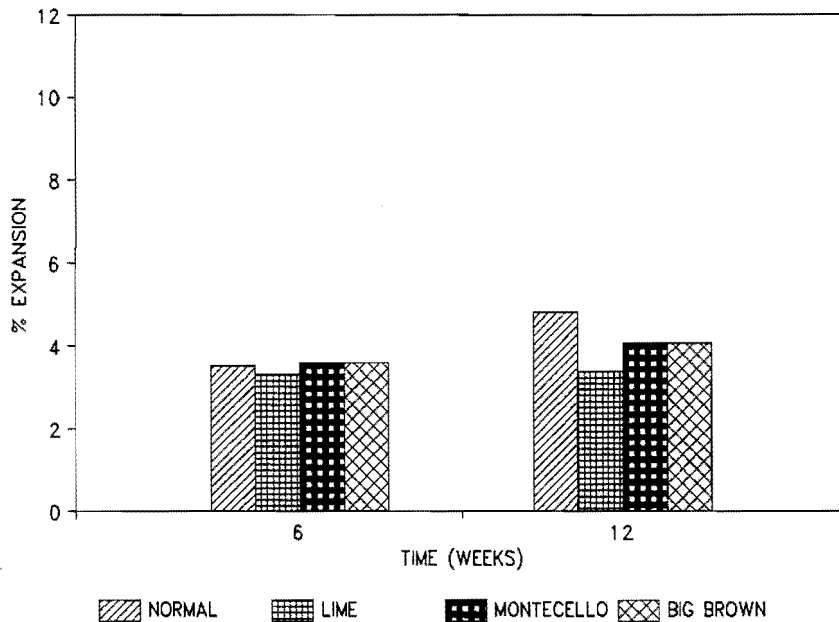

Figure 27a. Expansion of an Eddy Clay Upon Stabilization with Various Low Calcium Fly-Ashes.

The Beaumont clay had a slightly higher sulfate concentration of 1.2 meq/l (1:2 soil:water ratio). This sulfate concentration is also relatively low, and sulfate heave is not expected. Figure 27(b) shows the expansion of samples stabilized with hydrated lime and low calcium fly-ashes. The Sandow and Montecello low calcium fly-ash stabilizers performed best in keeping the soil from expanding. The sample stabilized with hydrated lime experienced less expansion than the un-stabilized samples, but the sample stabilized with the Big Brown low calcium fly-ash experienced almost the same amount of expansion as the un-stabilized sample. The differences in expansion between the Sandow, Montecello, and hydrated lime are insignificantly small.

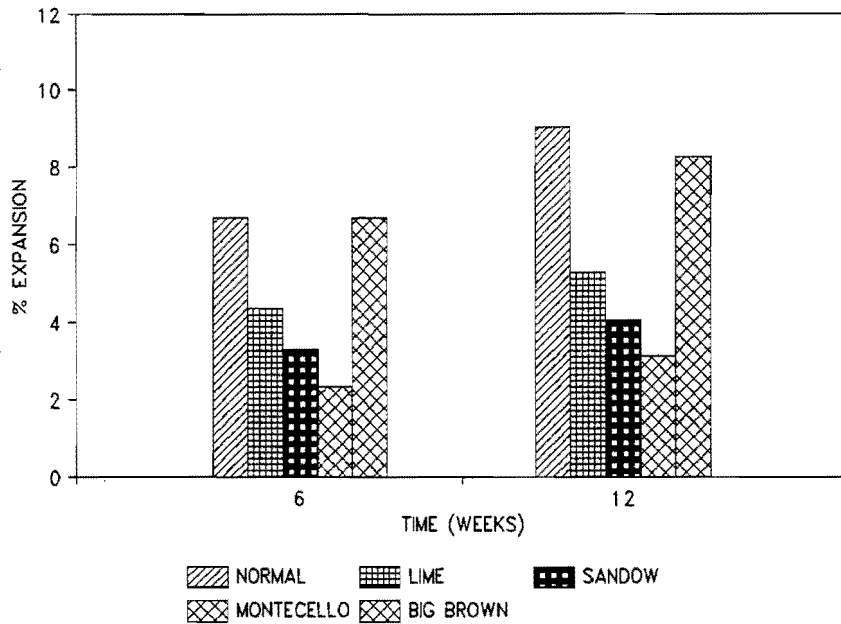

Figure 27b. Expansion of a Beaumont Clay Upon Stabilization with Various Low Calcium Fly-Ashes.

The Houston black clay had a sulfate concentration of 1.1 meq/l (1:2 soil:water ratio). Despite the relatively low sulfate concentration, the samples stabilized with low calcium fly-ash seemed to perform better than the sample stabilized with lime. The expansion of Houston black clay samples is shown in Figure 27(c). Regarding the low calcium fly-ashes, the Big Brown performed worst in keeping the soil from expanding. However, the difference in expansion between samples stabilized with low calcium fly-ashes seems to be insignificant.

The kaolinitic clay had the highest sulfate concentration of 12 meq/l (soil:water ratio of 1:2). This sulfate concentration is relatively high, and sulfate heave could be expected. The sample that was not stabilized and the sample stabilized with hydrated lime both expanded more than 8% after three weeks passed; after that they came apart, and no further expansion could be monitored. The samples stabilized with low calcium fly-ashes experienced a maximum expansion of only about 4% after 12 weeks. This indicates the usefulness of low calcium fly-ashes as stabilizer in sulfate bearing clay soils.

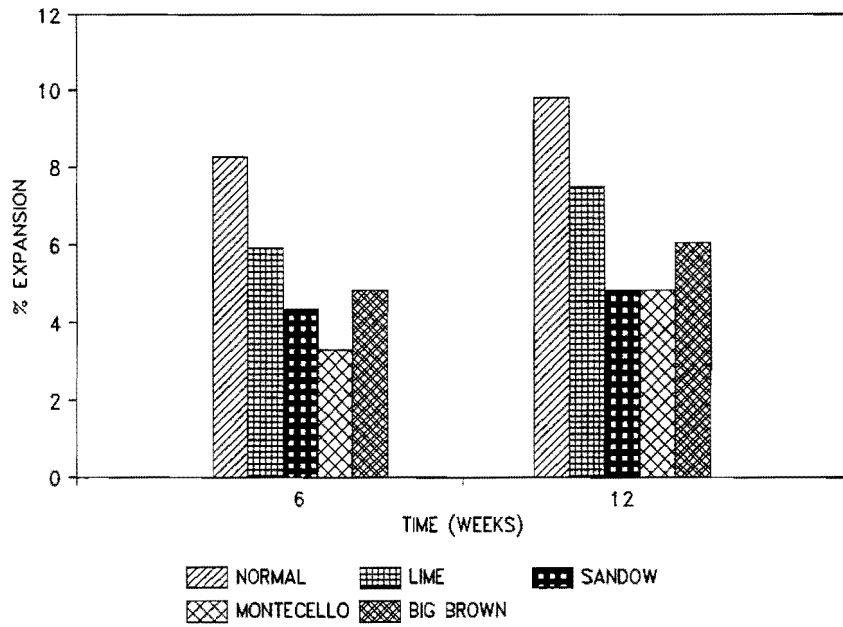

Figure 27c. Expansion of a Houston Black Clay Upon Stabilization with Various Low Calcium Fly-Ashes.

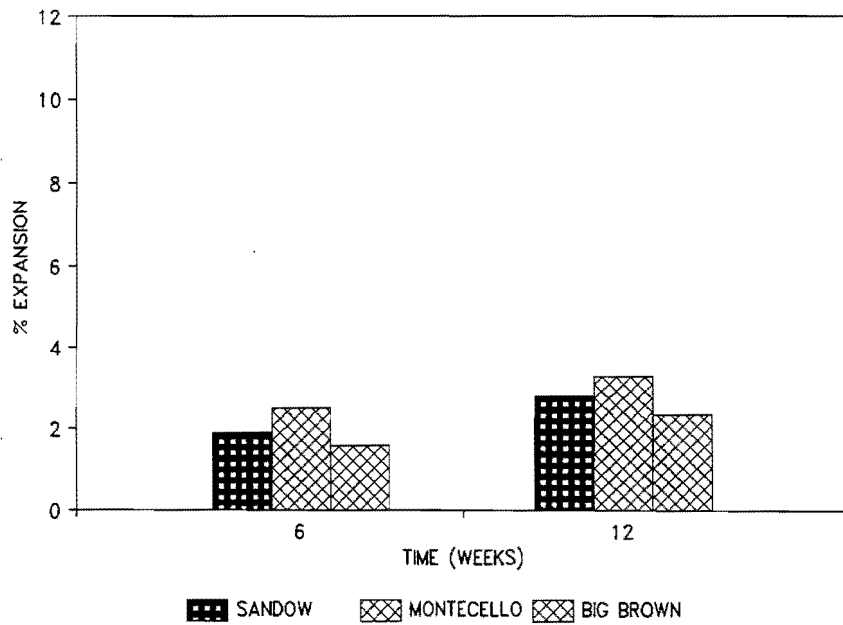

Figure 27d. Expansion of a Kaolinitic Clay Upon Stabilization with Various Low Calcium Fly-Ashes.

RESULTS OF LOW CALCIUM FLY-ASH STABILIZATION ON FM 1382 SITE NO 7

The sample that experienced the highest amount of expansion upon lime stabilization was Sample No. 7 from FM 1382. Chapter 3 discusses the expansion of this sample. This sample contained the highest sulfate concentration of all the soils under investigation, namely, 184.3 meq/l (1:0.5 soil:water ratio). From Figure 11(a), it can be seen that this sample expanded 18% upon lime stabilization after a period of 16 weeks. The sample that was not lime stabilized expanded 14% after 16 weeks. The expansion of these samples is compared to a sample of the same soil that was stabilized with Montecello low calcium fly-ash after 6 and 12 weeks. The results are presented in Figure 28. It is evident that the low calcium fly-ash succeeded in reducing the amount of expansion encountered after hydrated lime stabilization.

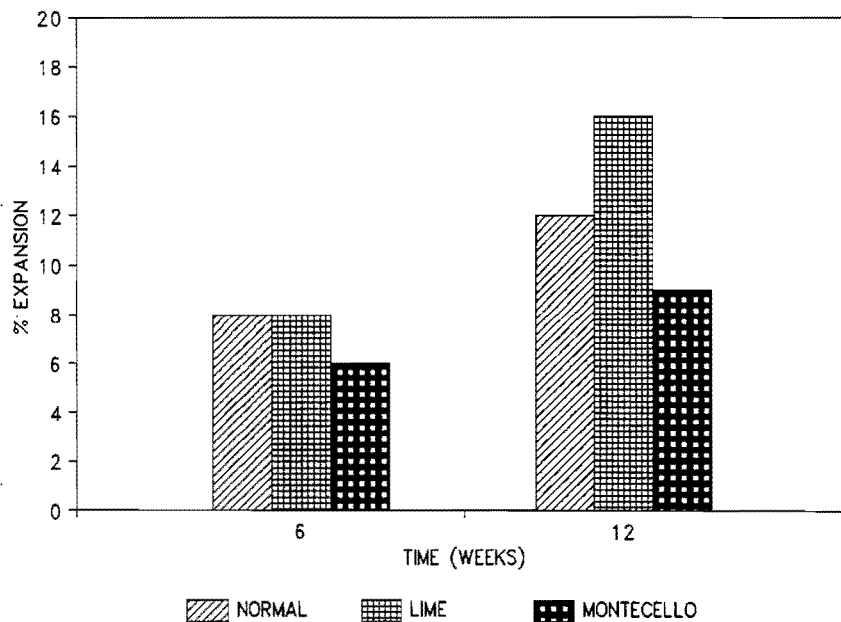

Figure 28. Expansion of Eddy Clay from FM 1382 Site No 7 Upon Stabilization with Montecello Low Calcium Fly-Ash.

EVALUATION OF DIFFERENT LOW CALCIUM FLY-ASHES AS STABILIZERS

The amounts of expansion of each of the low calcium fly-ash stabilizers were added together, and an average amount of expansion was calculated for each low calcium fly-ash stabilizer. This average amount of expansion is plotted against the calcium concentration of each of the low calcium fly-ashes, and the plot is shown in Figure 29. The average expansion of all the samples stabilized with hydrated lime is also shown in Figure 29. The average amount of calcium in hydrated lime is about 80%. The low calcium fly-ashes performed better than the hydrated lime in prohibiting expansion of the clay soils; however, this is only true because of the relatively high sulfate concentration in some of the soils under investigation. The small difference in the amount of calcium between the different low calcium fly ash stabilizers does not seem to have much relation to the amount of expansion. It is, however, evident that the Big Brown did not perform as well as the other two stabilizers.

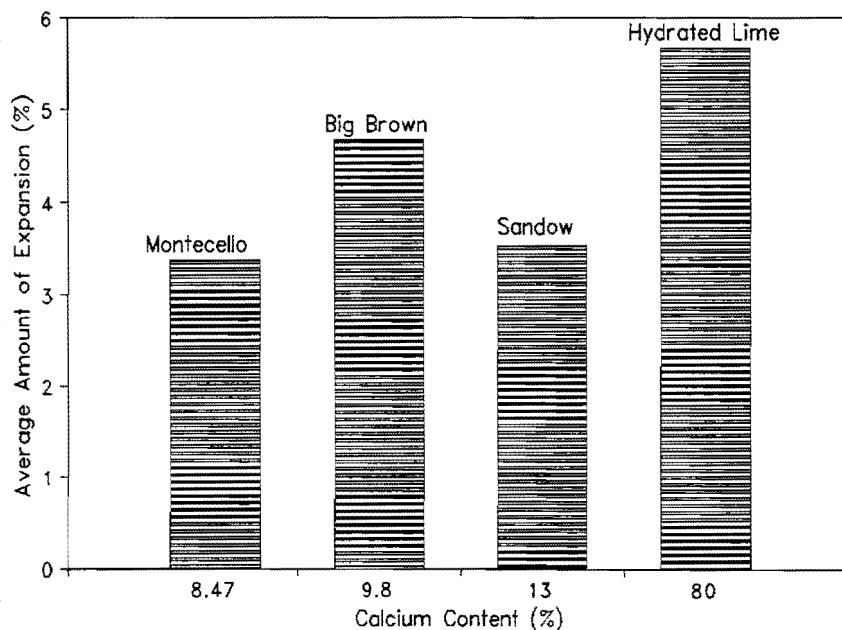

Figure 29. The Average Amount of Expansion for Each Stabilizer vs. the Calcium Content of the Stabilizer.

CONCLUSIONS

- Soils with a relatively low sulfate content like the Eddy clay, the Houston black clay, and the Beaumont clay performed well after stabilization with hydrated lime and low calcium fly-ash.
- When the sulfate concentration is relatively low, hydrated lime could be used with as much success as low calcium fly-ashes.
- For low sulfate concentrations, the difference between expansion of low calcium fly-ash and hydrated lime stabilized samples seems insignificant.
- With relatively high sulfate concentrations, hydrated lime does not seem to reduce the expansion of clay soils. In some cases, the addition of hydrated lime is even more deleterious than no stabilization at all. However, low calcium fly-ash seems to minimize the amount of expansion that occurs.
- From Figure 28, it is evident that the overall average expansion of samples stabilized with low calcium fly-ashes is lower than the overall average expansion of samples stabilized with hydrated lime. However, this seems to be true only when considering soils with relatively high sulfate contents. A small difference in calcium content seems not to have any relation to the amount of expansion encountered. However, the Big Brown did not perform as well as the other two low calcium fly-ash stabilizers.
- It is suggested that low calcium fly-ashes be used with relatively high sulfate concentrations, while hydrated lime could be used when sulfate concentrations are relatively low.

CHAPTER 8

INTERACTIVE DISCUSSION OF ALL RESULTS

INTRODUCTION

The results obtained from expansion tests and electrical conductivity tests on samples containing different amounts of sulfates were presented in Chapters 3 and 4, respectively. The results of CEC and dielectric constant determination were presented in Chapter 5, and the results of low calcium fly-ash stabilization were presented in Chapter 6. All of these results were discussed individually at the end of each chapter.

It is now necessary to investigate possible interactions between the results obtained in the last four chapters. A statistical regression model has been used to determine interaction between expansion, electrical conductivity (EC), sulfate content, CEC, and dielectric constant (DC) of the various soil samples under investigation. The results of this statistical model will be presented and discussed in this chapter.

The results can be divided into four groups. Two of the groups use the percentage of expansion of soil samples without the addition of lime as a response variable. The first group is composed of the four clay soil samples, and the other constitutes the samples obtained from IH 45 and FM 1382.

The other two groups use the percentage of expansion of soil samples with the addition of 6% hydrated lime as a response variable. Once again, the four clay soil samples are modeled separately from samples obtained from IH 45 and FM 1382. The reason for this is the sulfate content determination at different soil:water ratios which cannot be compared.

MODEL 1: REGRESSION MODELING WITH % EXPANSION WITHOUT LIME AS RESPONSE VARIABLE FOR THE FOUR CLAY SOIL SAMPLES

The results from different experimental procedures that were used to perform a regression analysis are presented in Table 9.

Table 9. Results of Various Experimental Procedures for the Four Clay Soil Samples (Without Lime).

Soil Type	% Expansion (No Lime)	Sulfate Content (meq/l)	CEC (meq/100g)	EC (mS/cm)	DC
Eddy clay	3.28	0.4	8.5	0.295	48
Beaumont clay	6.72	1.2	38.2	0.510	60.8
HBC	8.44	1.1	36.5	0.760	62.5
Kaolinitic clay	15.00	12	3.2	0.601	54.2

All of the results reported are from soil samples containing no lime and no added sulfates. The amounts of expansion of the samples are reported after 6 weeks of exposure to cold and humid conditions. After 6 weeks, the kaolinitic clay had fallen apart, and expansion could not be monitored. However, a conservative calculated guess has been made regarding the expansion of the kaolinitic clay in order to be able to perform a regression analysis on the data.

The following equation describes the proposed full model:

$$\text{Exlime} = \beta_0 + \beta_1\text{Sulf} + \beta_2\text{CEC} + \beta_3\text{EC} + \beta_4\text{DC}$$

where

Exnolime = % Expansion of soil samples without addition of lime

Sulf = Sulfate content (meq/l)

CEC = Cation Exchange Capacity (Meq/100g)

EC = Electrical Conductivity (mS/cm)

DC = Dielectric Constant (GHz)

Because the number of parameters do not exceed the rank, the least-squares solutions for the parameters are not unique and, therefore, some statistics will be misleading (20). The parameter estimates for the full model are biased, and the full model had to be rejected. It

was, however, possible to obtain Pearson Correlation Coefficients for all the parameters (20). Table 10 presents correlation coefficients.

Table 10. Pearson Correlation Coefficients for Expansion of Clay Soil Samples Containing No Lime, and Other Parameters (19).

	Exnolime	Sulf	CEC	EC	DC
Exnolime	1.000	0.923	-0.302	0.603	0.218
Sulf	0.923	1.000	-0.620	0.258	-0.157
CEC	-0.302	-0.620	1.000	0.452	0.862
EC	0.603	0.258	0.452	1.000	0.809
DC	0.218	-0.157	0.862	0.809	1.000

Parameters that are highly correlated with the amount of expansion are the sulfate content and the electrical conductivity with correlation coefficients of 0.923 and 0.603, respectively. Other parameters that are correlated with each other are the dielectric constant with CEC and electrical conductivity. However, since these parameters do not seem to correlate with the amount of expansion, they could be omitted. The following reduced model is proposed:

$$\text{Exnolime} = \beta_0 + \beta_1\text{Sulf} + \beta_2\text{EC}$$

This model does not have the same problem as the full model since the number of parameters is greater than the rank of the model. The parameter estimates for the reduced model as produced by the SAS-program output are as follows:

$$\begin{aligned} \beta_0 &= 0.000 \\ \beta_1 &= 1.071 \\ \beta_2 &= 1.071 \end{aligned}$$

MODEL 2: REGRESSION MODELING WITH % EXPANSION WITH 6% LIME AS RESPONSE VARIABLE FOR THE FOUR CLAY SOIL SAMPLES

Table 11 contains the data used to perform a regression analysis on the four clay soil samples with the amount of expansion after lime stabilization as the response variable. The analysis was performed in exactly the same way as described in the previous section. Again, the full model was rejected. The Pearson correlation coefficients are presented in Table 12. The correlation coefficients vary only with insignificant small amounts from those in the previous section. Because of the similarity in the two models, the same reduced model is proposed with exactly the same parameter estimates.

Table 11. Results of Various Experimental Procedures for the Four Clay Soil Samples (With Lime).

Soil Type	% Expansion (6% Lime)	Sulfate Content (meq/l)	CEC (meq/100g)	EC (mS/cm)	DC (GHz)
Eddy clay	2.969	0.4	8.5	0.295	48
Beaumont clay	7.813	1.2	38.2	0.510	60.8
HBC	6.563	1.1	36.5	0.760	62.5
Kaolinitic clay	15.00	12	3.2	0.601	54

Table 12. Pearson Correlation Coefficients for Expansion of Clay Soil Samples Containing 6% Lime, and Other Parameters (19).

	Exlime	Sulf	CEC	EC	DC
Exlime	1.000	0.938	-0.315	0.463	0.172
Sulf	0.937	1.000	-0.620	0.258	-0.157
CEC	-0.315	-0.620	1.000	0.452	0.862
EC	0.463	0.258	0.452	1.000	0.809
DC	0.172	-0.157	0.862	0.809	1.000

MODEL 3: REGRESSION MODELING WITH % EXPANSION WITHOUT LIME AS RESPONSE VARIABLE FOR SOIL SAMPLES FROM FM 1382 AND IH 45

The results from different experimental procedures that were used to perform a regression analysis are presented in Table 13. No dielectric constant measurements were performed on samples from IH 45 and FM 1382. A full model for all the parameters can be represented by the following equation:

$$\text{Exnolime} = \beta_0 + \beta_1\text{Sulf} + \beta_2\text{CEC} + \beta_3\text{EC}$$

with parameter estimates from the SAS-program output as follows:

$$\begin{aligned}\beta_0 &= 1.776 \\ \beta_1 &= -0.013 \\ \beta_2 &= -0.040 \\ \beta_3 &= 0.377\end{aligned}$$

The hypothesis that a flat line describes the data best was rejected, and it was concluded that this fitted curve describes the data significantly better than a flat line.

The Pearson Correlation Coefficients which describe the interaction between the variables are presented in Table 14. It is evident that the sulfate content and electrical conductivity have a very high correlation with the amount of expansion of samples containing no lime. The sulfate content and electrical conductivity also correlate well with each other. It is evident that the CEC does not show any significant correlation with any of the other parameters. For this reason, the CEC could be omitted from the model, and the following reduced model is proposed:

$$\text{Exnolime} = \beta_0 + \beta_1\text{Sulf} + \beta_2\text{EC}$$

The parameter estimates as produced by the SAS-program output are as follows:

$$\begin{aligned}\beta_0 &= 0.986 \\ \beta_1 &= -0.006 \\ \beta_2 &= 0.307\end{aligned}$$

The lack of fit F-Test was used to test the hypothesis that the reduced model is adequate (19). At a 95% level of confidence, it was concluded that the hypothesis could not be rejected, which means that the reduced model describes the data adequately, and the full model is unnecessary.

Table 13. Results of Various Experimental Procedures for Soil Samples from FM 1382 and IH 45 (Without Lime).

Soil Number	% Expansion (No lime)	Sulfate Content (Meq/l)	CEC (Meq/100g)	EC (mS/cm)
IH 45 1	1.875	0.7	26.6	2.7
2	3.380	0.5	30.4	2.5
3	1.860	0.5	31.2	2.5
4	1.570	0.7	9.2	1.9
6	0.620	1.3	16.7	2.0
8	0.310	0.6	16.3	1.9
9	1.24	0.5	37.5	2.3
FM 1382 1	6.27	45.5	14.3	4.3
2	1.56	3.5	19.3	2.4
3	0.31	0.4	10.6	1.6
5	0.94	5.6	35.6	2.7
7	8.62	184.3	35.6	27.7

Table 14. Pearson Correlation Coefficients for Expansion of Soil Samples from FM 1382 and IH 45 Containing No Lime, and Other Parameters (19).

	Exnolime	Sulf	CEC	EC
Exnolime	1.000	0.713	0.163	0.755
Sulf	0.713	1.000	0.279	0.959
CEC	0.163	0.279	1.000	0.369
EC	0.755	0.959	0.369	1.000

MODEL 4: REGRESSION MODELING WITH % EXPANSION WITH 6% LIME AS RESPONSE VARIABLE FOR SOIL SAMPLES FROM FM 1382 AND IH 45

The results from different experimental procedures that were used to perform a regression analysis are presented in Table 15. The hypothesis that a flat line described the data best was rejected, and the full model that describes the curvature in data is presented by the following equation:

$$\text{Exlime} = \beta_0 + \beta_1\text{Sulf} + \beta_2\text{CEC} + \beta_3\text{EC}$$

with parameter estimates from the SAS-program output as follows:

$$\begin{aligned}\beta_0 &= -0.408 \\ \beta_1 &= 0.000 \\ \beta_2 &= -0.013 \\ \beta_3 &= 0.512\end{aligned}$$

From Table 16, it is evident that the amount of expansion of the samples containing 6% lime correlates relatively well with the sulfate content and the electrical conductivity of the samples. On the other hand, the correlation between the electrical conductivity and the sulfate content of the samples is very high. Since the CEC does not seem to relate well to any of the other parameters, it could be omitted from the model, and a reduced model could be fitted to the data. The reduced model can be represented by the equation:

$$\text{Exlime} = \beta_0 + \beta_1\text{Sulf} + \beta_2\text{EC}$$

The parameter estimates as produced by the SAS-program output are as follows:

$$\begin{aligned}\beta_0 &= -0.670 \\ \beta_1 &= 0.002 \\ \beta_2 &= 0.448\end{aligned}$$

The lack of fit F-Test was once again used to determine that the reduced model is adequate and that the full model is not needed (19).

Table 15. Results of Various Experimental Procedures for Soil Samples from FM 1382 and IH 45 (With Lime).

Soil Number	% Expansion (6% lime)	Sulfate Content (Meq/l)	CEC (Meq/100g)	EC (mS/cm)
IH 45 1	0.23	0.7	26.6	2.7
2	0.15	0.5	30.4	2.5
3	0.94	0.5	31.2	2.5
4	0.31	0.7	9.2	1.9
6	0.00	1.3	16.7	2.0
8	0.31	0.6	16.3	1.9
9	0.31	0.5	37.5	2.3
FM 1382 1	0.56	45.5	14.3	4.3
2	0.63	3.5	19.3	2.4
3	0.63	0.4	10.6	1.6
5	4	5.6	35.6	2.7
7	13.31	184.3	35.6	27.7

Table 16. Pearson Correlation Coefficients for Expansion of Soil Samples from FM 1382 and IH 45 Containing 6% Lime, and Other Parameters (19).

	Exlime	Sulf	CEC	EC
Exlime	1.000	0.959	0.320	0.997
Sulf	0.959	1.000	0.254	0.959
CEC	0.320	0.254	1.000	0.351
EC	0.997	0.959	0.351	1.000

MODEL FOR DETERMINATION OF AMOUNT OF EXPANSION EXPERIENCED BY SULFATE BEARING CLAY SOILS

In each of the four regression analyses performed in this chapter, the data were best described by a model containing only expansion, electrical conductivity, and natural sulfate content of the soil samples as parameters. From the correlation coefficients obtained for each model as well as from the regression equations obtained in Chapter 4, it can be seen that electrical conductivity relates well to sulfate content. The regression models from Chapter 4 were as follows:

- a) For soil samples from FM 1382 and IH 45 with a soil:water ratio of 1:20

$$EC = \exp\{0.799 + 0.014(\text{sulfate content})\}$$

- b) For the four clay soil samples with a soil:water ratio of 1:2

$$EC = 5.785(\text{sulfate content}) + 0.623$$

Electrical conductivity of soil can be measured with a permittivity probe on in situ soil in the field with great ease. Depending on the soil:water ratio used to make a soil paste on which electrical conductivity is measured, one of the above equations could be used to estimate the amount of sulfates present in the soil.

Once the amount of sulfates and the electrical conductivity are known, the suitable regression model from this chapter could be used to determine an estimated amount of expansion. If this amount exceeds the maximum allowable amount of expansion, low calcium fly-ash should be used to stabilize the soil, rather than hydrated lime.

Because the amount of sulfates is a function of the electrical conductivity, the equations obtained in Chapter 4 could be substituted into each model, and the regression equations could be written in the following way:

Model 1:

$$\text{Exnolime} = 1.255(\text{EC}) - 0.11526$$

Model 2:

$$\text{Exlime} = 1.255(\text{EC}) - 0.11526$$

Model 3:

$$\text{Exnolime} = 1.328 - 0.429\text{Ln}(\text{EC}) + 0.307(\text{EC})$$

Model 4:

$$\text{Exlime} = 0.43\text{Ln}(\text{EC}) + 0.488(\text{EC}) - 0.784$$

Models 1 and 2 are the same and should be used when the soil:water ratio of the paste from which the electrical conductivity was measured is 1:2. Models 3 and 4 should be used if electrical conductivity was measured on a soil paste with a soil:water ratio of 1:20.

Since it is anticipated that soil with a high sulfate content should expand more upon lime stabilization, it does not make sense to use the same model for predicting expansion with and without lime stabilization. The reason models 1 and 2 are the same is probably because none of the four clay soils used in predicting these models contained substantially high amounts of natural sulfates to cause ettringite formation. In contrast to models 3 and 4, the expansion of soils in models 1 and 2 was probably not sulfate related. It is proposed that models 3 and 4 be used to predict expansion of soils before and after lime stabilization, respectively.

CONCLUSIONS

- Four regression models were suggested which relate the results from different experimental procedures to each other. Each of full models contained electrical conductivity, CEC, dielectric constant, and the amount of soluble sulfates as parameters with the amount of expansion with or without lime as a response variable.
- In each case, a reduced model has been proposed and accepted. For each of the models, the reduced model had only sulfate content and electrical conductivity as parameters.

- Model 1 and 2 are exactly the same, which means the amount of expansion before and after lime stabilization would be equivalent. This does not make sense since the amount of expansion should be less after lime stabilization of soils that do not contain sulfates, and if the stated hypothesis holds true, the amount of expansion after lime stabilization should be higher upon stabilization of sulfate bearing soils. Thus, models 1 and 2 should not be used.
- None of the four clay soils used in the experimentation to obtain models 1 and 2 contained high amounts of natural sulfates. The kaolinitic clay contained the highest amount of sulfates which was 0.06%. The relatively high amount of expansion experienced by this clay soil was probably due to its high plasticity and surface area and was not sulfate related.
- Models 3 and 4 were obtained from experimental data on soils from FM 1382 and IH 45. Natural sulfate contents of up to 0.9% were encountered in some of the soil samples. Model 3 provides an equation for the calculation of expansion of soil samples that is not lime stabilized. Model 4 provides a similar equation for expansion of soil samples that have been stabilized with 6% of hydrated lime.
- Models 3 and 4 may be used to calculate the amount of expansion as a function of the electrical conductivity as measured by the permittivity probe on a soil paste with 1:20 soil:water ratio.

CHAPTER 9

CONCLUSION

OVERALL CONCLUSIONS

In order to view the conclusions in their proper perspective, it will be useful to review the questions that were posed at the beginning of this investigation. These questions can be summarized as follows:

- Do sulfate bearing soils pose a problem when stabilized with lime?
- Can those soils that are susceptible to sulfate induced heave be identified?
- Is there a field-test procedure that can be used to predict the amount of expansion likely to occur?
- If lime stabilization causes sulfate induced heave in clay soils, what alternative method of stabilization can be used?

Proposed answers for these questions are:

- Mitchell (14) concluded that when sulfates are present in soil they could cause excessive heave in clay soils that have been stabilized with lime due to the formation of ettringite. In Chapter 3, it was shown that soils containing relatively high sulfate contents expanded more upon lime stabilization than soils not containing sulfates.
- The electrical conductivity of the soils under investigation relates well to the sulfate content in the soils and can be used to determine whether soil contains sulfates or not. Regression models that relate electrical conductivity to sulfate content were developed in Chapter 4.
- A permittivity probe can be used to measure electrical conductivity and dielectric constants of soil samples. In Chapter 7, a model was proposed that can predict the amount of expansion if the electrical conductivity and sulfate content of the soil are known. Since electrical conductivity could be measured in the field with a permittivity probe, and the sulfate content in soils is a function of electrical conductivity, both parameters are known and can be

substituted into equations that yield the amount of expansion with and without lime stabilization.

- It has been concluded that lime stabilization of sulfate bearing soils causes ettringite formation which leads to excessive heave. Chapter 6 proposes that low calcium fly-ash, like Sandow, Montecello, or Big Brown be used to stabilize clay soils that are likely to expand beyond acceptable levels. This expansion can typically be predicted with the model that was proposed in Chapter 7.

SUBJECTS PROPOSED FOR FURTHER INVESTIGATION

Only five soil properties were taken into account in this investigation. These properties are the amount of expansion, sulfate content, dielectric constant, cation exchange capacity, and electrical conductivity. Amongst these five properties, only sulfate content, electrical conductivity, and the amount of expansion had relatively good interaction with each other. There are numerous other soil properties that could be investigated. Two of these are the surface area and gradation of the soil which could easily be measured with modern laser technology. It could also be advantageous to have a full account of the mineralogical composition of the soil under investigation. However, it would not be possible to determine the mineralogical composition of in situ soil in the field with ease.

The equations developed to determine amounts of expansion of soil with and without lime stabilization are empirical. About 15 different soil samples were used to develop the relationships presented in this investigation. These soils all originated from Texas and, therefore, it is suggested that the equations should only be used for determining expansion of soil samples from the same geological formations. Similar equations could, however, be developed for other soil formations.

A characteristic of the soil in Texas is that sulfates seem to be the only salt that occurs in the top horizons of soil formation. This may be because sulfate is one of the most insoluble salts. All other salts are washed down to the maximum depth of penetration. For this reason, electrical conductivity relates well to the sulfate content

of soils. However, in areas with very low precipitation, other salts could be present in the top horizons and would have an influence on the electrical conductivity. The effect this will have on the prediction of sulfates in soil needs to be investigated.

Water leaching through sulfate bearing soils is believed to dissolve the sulfates in the soil and make the sulfates more available for reaction with calcium, to form ettringites. Isolating the sulfate bearing clay soils from moisture activity would lead to drastic reduction in sulfate related expansion. Vertical and horizontal moisture barriers proved to be effective in controlling moisture activity of soils underneath pavements (21). Although it is evident that moisture barriers reduce roughness wavelengths associated with expansive soils, it is now necessary to investigate the effectiveness of moisture barriers used in association with sulfate bearing clay soils.

CHAPTER 10

IMPLEMENTATION OF RESULTS

By using the models developed in chapter 8 of this report, it should now be possible to predict whether sulfate swell is probable to occur in clay soils and also the amount of sulfate related swell that could be expected.

The equipment needed to perform a field evaluation of the sulfate content in soils includes the following:

- a) Wide mouth plastic containers with water-proof lids,
- b) Distilled water,
- c) Battery driven digital scale that can measure up to 500 g (Figure 30),
- d) Hand held conductivity meter (Figure 31), and
- e) Calibration solutions for the conductivity meter.

The entire package costs less than \$600.

The procedure is as follows:

- Step 1: Find the location where the sulfate test is to be performed and use an auger to obtain two small soil samples at approximately 10 and 20 cm below the soil surface. Only 5 grams of soil is needed to perform the test.
- Step 2: Weigh approximately 5 g of each soil sample into two separate plastic containers. If the soil is wet, break lumps apart and leave the soil to air-dry for 1 to 2 hours. Record the exact dry weight of the samples.
- Step 3: Now add distilled water with a mass of exactly 20 times the dry weight of the soil sample to the dry sample. Tightly close the lid of the plastic container and shake vigorously until the soil dissolves and forms a homogeneous solution.
- Step 4: Calibrate the conductivity meter as described in the instruction manual accompanying the device.

Step 5: Take conductivity measurements on each soil:water mixture and record the data in milli Siemens (mS)

Note: 1 uS = 0.001 mS

From our limited experience, mixtures with a conductivity of more than 8 mS have a potential to cause problems.

Step 6: Use the following equation to determine an estimated amount of expansion that would occur upon lime stabilization:

$$\% \text{ Expansion} = 0.43\text{Ln}(\text{EC}) + 0.488(\text{EC}) - 0.784$$

where EC = Electrical Conductivity measurement in mS, and %

Expansion = Anticipated swell after curing in moist environment for 7 days.

REFERENCES

1. T.M. Petry and D.N. Little. Update on Sulfate-Induced Heave in Treated Clays; Problematic Sulfate Levels. *Transportation Research Record 1362*, TRB, National Research Council, Washington, DC, pp. 51 - 55.
2. G.A. Ferris, J.L. Eades, R.E. Graves, and G.H. McClellan. Improved Characteristics in Sulfate Soils Treated with Barium Compounds Before Lime Stabilization. *Transportation Research Record 1295*, TRB, National Research Council, Washington, DC, pp. 45 - 51.
3. D. Hunter. Lime-Induced Heave in Sulfate-Bearing Clay Soils. *Journal of Geotechnical Engineering* 22168. Vol. 114, No. 2, February 1988, pp. 150 - 167.
4. L.A. Richards, L.E. Allison, L. Bernstein, C.A. Bower, J.W. Brown et al. *Diagnosis and Improvement of Saline and Alkali soils*. Agriculture Handbook No. 60, United States Department of Agriculture. U.S. Government Printing Office, Washington, DC, February 1954.
5. J.D. Rhoades and A.D. Halvorson. *Electrical Conductivity Methods for Detecting and Delineating Saline Seeps and Measuring Salinity in Northern Great Plains Soils*. Agriculture Research Service W-42. United States Department of Agriculture, March 1977. (Available in Texas A&M University Library, Documents Division)
6. I. Shainberg and J. Shalhevet. *Soil Salinity under Irrigation Processes and Management*. Ecological Studies Vol. 51. Springer-Verlag, New York, 1984.
7. T. Plakk. *HF Permittivity Measurements by Capacitive Probe*. Adek LTD Uus-Saku 12-1. Saku EE3400, Estonia. (Personal collection of Sanet Bredenkamp)
8. M. Whitney and L.J. Briggs. *An Electrical Method of Determining the Temperature of Soils*. U.S. Department of Agriculture, Division Soils Bulletin 7, 15 pp.

9. *Soil Survey of Dallas County, Texas*. United States Department of Agriculture Soil Conservation Service in Cooperation with Texas Agricultural Experiment Station. February 1980. (Available in TTI Library, Texas A&M University, Civil Engineering Department, Materials Division, CE\TTI Building)
10. J.B. Dixon and S.B. Weed. *Minerals in Soil Environments*. SSSA Book Series No. 1. Published by Soil Science Society of America, Madison, WI, 1989.
11. S. Bredenkamp and J.B. Dixon. *Analysis of an Eddy Clay*. Final report for AGRO 626. Texas A&M University, College Station, December 1993.
12. V.C. Farmer and J.D. Russel. *Interlayer Complexes in Layer Silicates. The Structure of Water in Lamellar Ionic Solutions*. Trans Faraday Society Vol. 67, No. 2737, pp. 345 - 365, 1971. (Personal collection of Dr. J.B. Dixon, Texas A&M University, Agronomy Department).
13. *Handbook for Stabilization of Pavement Subgrades and Base Courses with Lime*. National Lime Association, December 1993. (Personal collection of Dr. Dallas N. Little, Texas A&M University, Civil Engineering Department).
14. K. Mitchell. Practical Problems from Surprising Soil Behavior. (The Twentieth Karl Terzaghi Lecture). *Journal of Geotechnical Engineering*. Vol. 112, No. 3, March 1986, pp. 259 - 289.
15. R.D. Holtz and W.D. Kovacs. *An Introduction to Geotechnical Engineering*. Prentice-Hall, Englewood Cliffs, NJ, 1989.
16. EPA Method No 9050. *Specific Conductance*. Soil Analytical Services Inc. College Station, TX, Revised, September 1986.
17. EPA Method No 9081. *Cation Exchange Capacity of Soils*. Soil Analytical Services Inc. Revised, September 1986.
18. EPA Method No 9038. *Soluble Sulfates (Turbidimetric)*. Soil Analytical Services Inc. Revised, September 1986.
19. J.S. Milton and J.C. Arnold. *Introduction to Probability and Statistics: Principles and Application for Engineering and the Computing Sciences*. McGraw-Hill Publishing Company, 1990.

20. EPA Method No 9040. *PH Electrometric Measurement*. Soil Analytical Services Inc. Revised, September 1986.
21. F.N. Nyangaga, R.L. Lytton and D.A. Gay. *Effects of vertical moisture barriers on roughness development of pavements on expansive soils*. First International Conference on Unsaturated Soils. Paris, 1995.

APPENDIX A

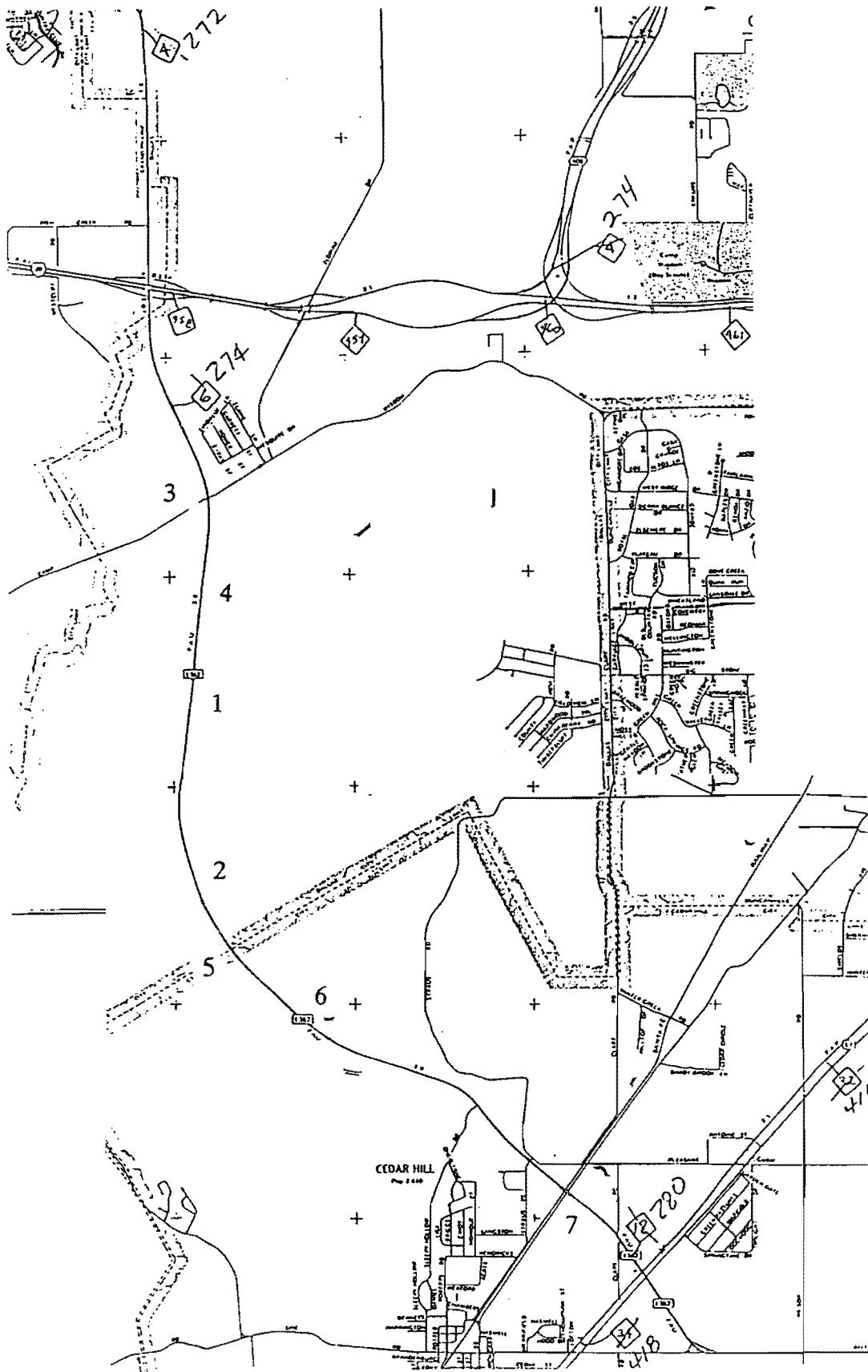

Locations from which Soil Samples Were Taken Along FM 1382

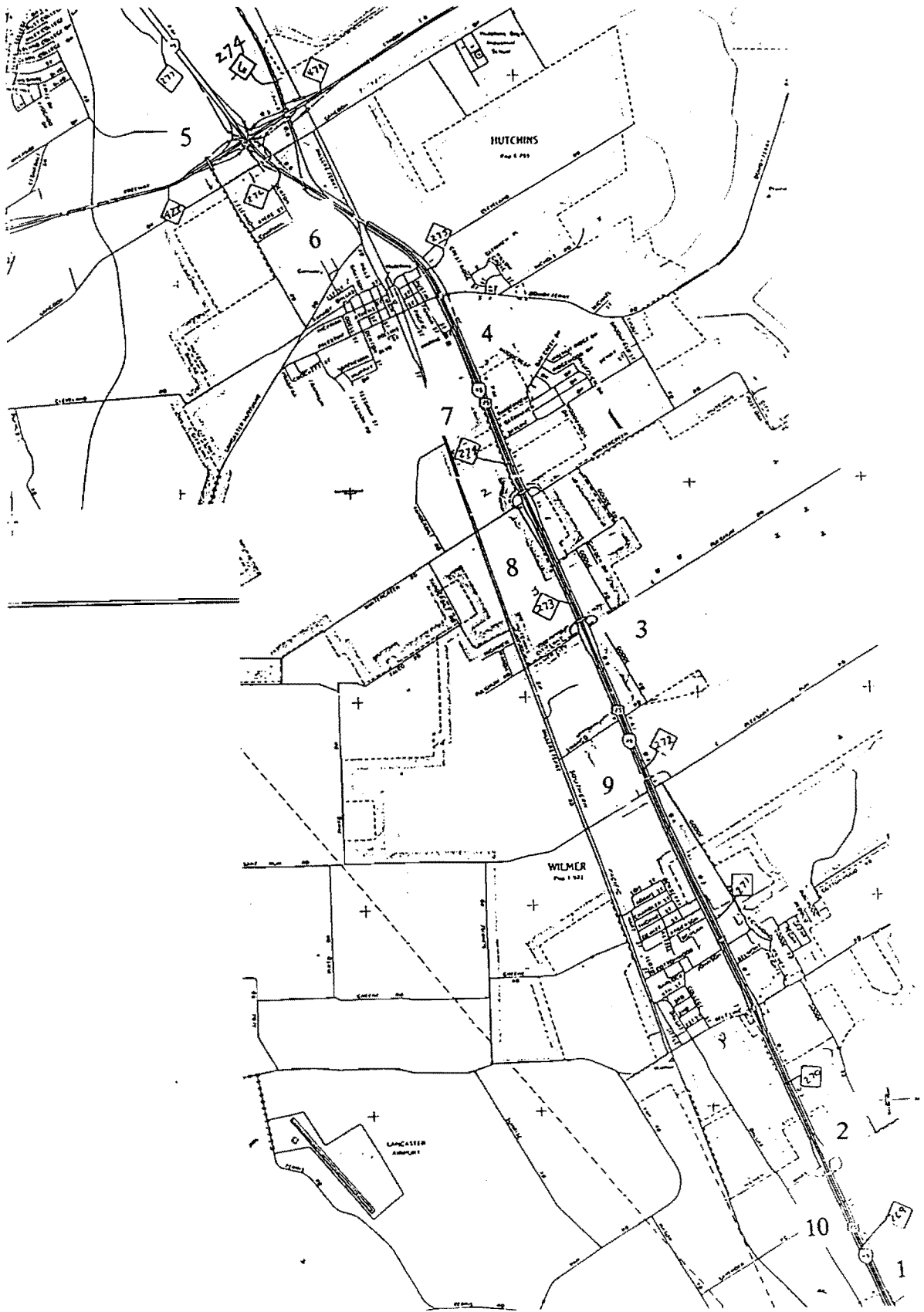

Locations from which Soil Samples Were Taken Along IH 45

APPENDIX B

RELATION BETWEEN PH OF CLAY SOILS AND AMOUNT OF EXPANSION ENCOUNTERED

One of the tasks of this report was to investigate the effect of high pH liquids on the expansion of sulfate bearing clay soils. The pH of each of the soil samples from IH 45 and FM 1382 was measured using EPA-method No. 9040 (20). The pH of a sample is determined electrometrically using either a glass electrode in combination with a reference potential or a combination electrode (20). The pH values for these clay soil samples varied between a pH of 7.8 and 9.2. Figure 32 shows the relation between the pH of each sample to the amount of expansion encountered after lime stabilization. From this figure it is clear that there is no apparent relationship between the amount of expansion that occurs after lime stabilization and the pH of the clay soil.

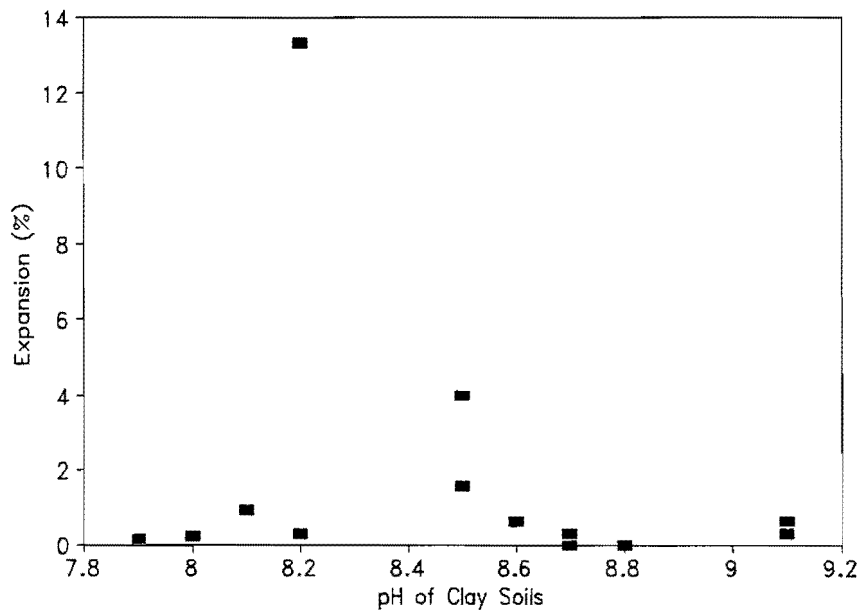

Figure 32. Relation Between pH of Clay Soils and the Amount of Expansion After Lime Stabilization.

This phenomena validated the decision to abandon all further research concerning raising the pH of the sulfate bearing clay soil samples. Another reason for abandoning this investigation was because of the high cost involved in entering the high pH liquids into the low permeability clay soils.