

1. Report No. TX-98/1958-2F		2. Government Accession No.		3. Recipient's Catalog No.	
4. Title and Subtitle DESIGN AND IMPLEMENTATION OF AUTOMATIC VEHICLE IDENTIFICATION TECHNOLOGIES FOR TRAFFIC MONITORING IN HOUSTON, TEXAS				5. Report Date September 1996	
				6. Performing Organization Code	
7. Author(s) Dennis G. Smalley, Dan R. Hickman, and William R. McCasland				8. Performing Organization Report No. Research Report 1958-2F	
9. Performing Organization Name and Address Texas Transportation Institute The Texas A&M University System College Station, Texas 77843-3135				10. Work Unit No. (TRAVIS)	
				11. Contract or Grant No. Study No. 7-1958	
12. Sponsoring Agency Name and Address Texas Department of Transportation Research and Technology Transfer Office P. O. Box 5080 Austin, Texas 78763-5080				13. Type of Report and Period Covered Final: September 1993 - August 1996	
				14. Sponsoring Agency Code	
15. Supplementary Notes Research performed in cooperation with the Texas Department of Transportation. Research Study Title: Development and Implementation of an Automatic Vehicle Identification (AVI) System for Several Freeways and High Occupancy Vehicle (HOV) Lanes					
16. Abstract This report documents the development of an Automatic Vehicle Identification (AVI) system for monitoring traffic conditions on urban freeways. The AVI system is being implemented in Houston in a stage construction program. Phase 1 covers 60 miles of urban roadways on three radial freeways. The report outlines the system design and the hardware and software requirements for measuring travel times and average speeds and processing and distributing the results in real time (with one minute of detection).					
17. Key Words Intelligent Transportation Systems, Traffic Management, Traffic Monitoring, Real-Time Travel Time Information, Automatic Vehicle Identification			18. Distribution Statement No restrictions. This document is available to the public through NTIS: National Technical Information Service 5285 Port Royal Road Springfield, Virginia 22161		
19. Security Classif.(of this report) Unclassified		20. Security Classif.(of this page) Unclassified		21. No. of Pages 60	22. Price

DESIGN AND IMPLEMENTATION OF
AUTOMATIC VEHICLE IDENTIFICATION TECHNOLOGIES FOR
TRAFFIC MONITORING IN HOUSTON, TEXAS

by

Dennis G. Smalley
Research Associate
Texas Transportation Institute

Dan R. Hickman
Research Associate
Texas Transportation Institute

and

William R. McCasland, P.E.
Research Engineer
Texas Transportation Institute

Research Report 1958-2F
Research Study Number 7-1958
Research Study Title: Development and Implementation of an Automatic
Vehicle Identification (AVI) System for Several Freeways
and High Occupancy Vehicle (HOV) Lanes

Sponsored by the
Texas Department of Transportation

September 1996

TEXAS TRANSPORTATION INSTITUTE
The Texas A&M University System
College Station, Texas 77843-3135

IMPLEMENTATION STATEMENT

This project identifies a number of valuable institutional, operational, and logistical lessons related to developing a real-time travel information program. The use of the Automatic Vehicle Identification (AVI) technology for gathering, processing, and analyzing data was found to be an effective and timely procedure.

The time required to install an AVI system to monitor long sections of freeway was much less than the conventional traffic surveillance systems. With sufficient numbers of vehicles equipped with electronic tags, accurate travel time information could be updated two to five times per minute during peak travel times and two to four times per minute during off-peak travel times. The travel time results from the AVI system are easily disseminated to the public through various information systems and to the operating agencies over computer networks.

The project results present a fully implemented traffic information system that can be duplicated in other cities.

DISCLAIMER

The contents of this report reflect the views of the authors who are responsible for the facts and the accuracy of the data presented herein. The contents do not necessarily reflect the official views or policies of the Texas Department of Transportation (TxDOT). This report does not constitute a standard, specification, or regulation. It is not intended for construction, bidding, or permit purposes. The engineer in charge of this project was William R. McCasland, P.E. #21746.

TABLE OF CONTENTS

	<u>Page</u>
LIST OF FIGURES	xi
LIST OF TABLES	xii
SUMMARY.....	xiii
GOAL	xiii
OBJECTIVE	xiii
CONCLUSIONS	xiv
INTRODUCTION	1
PROGRAM PURPOSE	3
PROGRAM TECHNOLOGY	3
TRAFFIC PROBES	4
FUNDING	8
SYSTEM DESIGN	9
GENERAL GUIDELINES	9
FIELD INSTALLATION DESIGN	11
ANTENNA DESIGN	11
FREQUENCY OF PROBES	15
FIELD TO CENTRAL COMMUNICATIONS	17
DATA PROCESSING SYSTEMS	20
SYSTEM OPERATIONS	27
GENERAL OPERATION	27
INFORMATION DISTRIBUTION	28
SYSTEM MODIFICATIONS	34
INSTALLATION COSTS	35
OPERATIONS/MAINTENANCE COSTS	35

TABLE OF CONTENTS (continued)

	<u>Page</u>
CLOSURE.....	41
SUMMARY	41
BENEFITS	42
FUTURE PLANS	42
REFERENCES	45

LIST OF FIGURES

	<u>Page</u>
Figure 1. Automatic Vehicle Identification (AVI) System Antenna/Reader Station Location and Phase Construction	2
Figure 2. TC Jester Overpass (I-10W)	12
Figure 3. Overhead Sign Structure East of W. 34th Street (US 290)	12
Figure 4. Overhead Sign Structure East of FM 1960 (US 290 WB Mainlanes)	13
Figure 5. HOVL Overhead CMS Structure (I-10 West of I-610)	13
Figure 6. Side-Mount Sign Structure at N. Shepherd (I-45 NB-Gulfbank Exit)	14
Figure 7. AVI Antennas at N. Shepherd Sign Structure	14
Figure 8. AVI Field Read Station	15
Figure 9. Field to Central Communications	18
Figure 10. Wireless Modem Antennas	19
Figure 11. AVI System Data Flow	21
Figure 12. Sample Color-Coded Map Image	24
Figure 13. Original Network Setup and Data Flow	25
Figure 14. Current Network Setup and Data Flow	26
Figure 15. Houston TranStar	29
Figure 16. Control Center	29
Figure 17. Sample Segment Data Report	30
Figure 18. Sample Tabular Data Report	31
Figure 19. Route Builder Report	32

LIST OF TABLES

	<u>Page</u>
Table 1. Number of Probes on All Freeways for Week: 07/15/96 to 07/19/96	6
Table 2. Number of Probes by Freeway for Week: 07/15/96 to 07/19/96	7
Table 3. Number of Reads by Freeway for Week: 07/15/96 to 07/19/96	7
Table 4. Results in February 1995	16
Table 5. Results in July 1996	16
Table 6. Project Cost-Phase 1	35
Table 7. Telephone Communication Costs	36

SUMMARY

GOAL

The goal of the project was to develop a traffic monitoring system that could be installed in a short time over a large network of freeways at a reasonable cost. The purpose was to provide timely information on the traffic conditions on the freeway, toll road, and High Occupancy Vehicle Lane (HOVL) system and make this information available to operators in the Houston Traffic Management Center (TranStar) for the purposes of incident detection and response and for dissemination to the traveling public by way of radio reports (traffic service companies) and roadside changeable message signs. Motorists could then select a route or mode of travel that would reduce their travel time.

OBJECTIVE

Specific objectives of the project were to:

- provide an electronic traffic monitoring system that utilizes an automatic vehicle identification (AVI) system using radio frequency identification (RFID) technology;
- select a system compatible with other Houston area transportation agencies operating or developing similar transportation monitoring technologies;
- require that all necessary electronic field equipment be installed above the traffic to minimize the inconvenience to the traveling public;
- require that the AVI system meet operational requirements for vehicle tag read accuracy and field data transmission during a test phase;
- solicit citizen volunteers as traffic probes; and
- provide a system that can be readily expanded.

CONCLUSIONS

The selection of Amtech System Corporation to provide the electronic technology for the project proved successful in achieving the requirements set forth by the TxDOT/TTI study staff during installation and testing phases of the project.

Forty-two hundred transponder tags were issued to citizen volunteers in Phases 1 and 2. These volunteers acted as traffic probes and provided the travel data for the program. Compatibility with the Harris County Toll Road Authority (HCTRA) automated toll collection program and other statewide Amtech installations provided access to over 50,000 additional vehicles with transponder tags. This high volume of transponders is desirable because the more transponders that are available in the traffic stream, the more frequently the database can be updated.

The Amtech technology lends itself to system expansion not only in geographic terms, but in adding interim reader stations to better identify incident locations.

Benefits of the AVI system are difficult to measure directly because its purpose is to provide information to the public by which travelers can make decisions about the route and timing of their trips. The AVI system has demonstrated that it can be a good source of information in identifying operational problems on the freeway, toll road, and HOVL system.

I. INTRODUCTION

Passage of the Intermodal Surface Transportation Efficiency Act of 1991 (ISTEA) provided a new direction for transportation system development and operation in the United States. With completion of the Interstate Highway System, the focus of national transportation policy shifted to multi-modal approaches which use existing and upgraded facilities efficiently. One of the new programs included in ISTEA to address this new direction is the Intelligent Vehicle-Highway System (IVHS) [now known as the Intelligent Transportation System (ITS)]. This program provides research and implementation funding for application of advanced technologies to the operation of transportation systems. The essence of ITS is to make improvements in mobility, highway safety, and productivity by improved transportation systems that apply advanced traffic control concepts, electronic technologies, and computer science. Thus, the new direction moves away from expansion of roadway systems by construction of new highways and toward improvements in operation of existing facilities and transportation services.

The ITS legislation challenges major urban areas to develop new approaches to minimizing peak period traffic congestion. One approach affects shifts in traffic demand in either space (route diversion), time (adjustments in time of departure), or travel mode (shifts to bus or carpool), with the traveler's decision based on real-time travel information. For trip pre-planning or in-progress trip changes to be meaningful, accurate and timely information on travel times, speeds, and roadway conditions must be available in easy-to-use formats.

In 1992, the Houston District of the Texas Department of Transportation (TxDOT) introduced the "Real-Time Information Program" (RTIP) and contracted with the Texas Transportation Institute (TTI) to develop necessary hardware and software systems. The program encompasses five phases. Phases 1, 2, and 3 (Figure 1) provide coverage of the central freeway system in the Harris County area. Phase 4 provides special applications of Automatic Vehicle Identification (AVI) for monitoring incident detection, HOV bus operations, and shuttle bus operations. Phase 5, which is not yet approved for implementation, expands the system on the Sam Houston Toll Way and provides initial installation on Beltway 8. Phases 1 and 2 are operational at the time of this report, and the reader sites are identified in Figure 1.

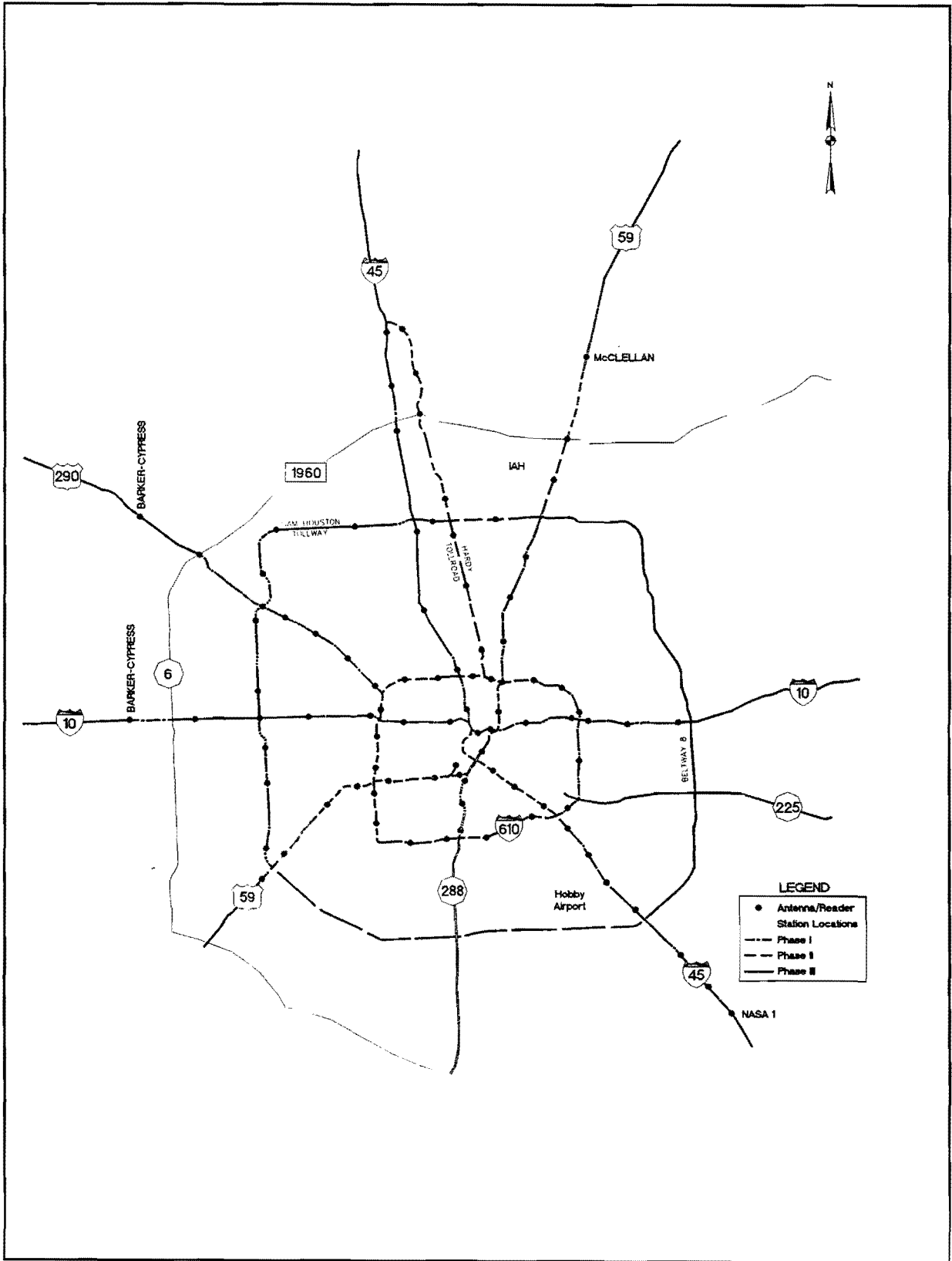

Figure 1. Automatic Vehicle Identification (AVI) System Antenna/Reader Station Location and Phase Construction

PROGRAM PURPOSE

The purpose of the program is to measure the travel time and average speed conditions of the freeway, toll road, and HOVL roadways and to relay this information back to the public in a timely manner by way of radio reports, roadside message signs, and other communication techniques. This information enables an individual to select an alternate route or different mode of travel, if the traveler can determine that the usual route is experiencing delay. The travel modifications would result in reduced delay for the diverted traffic and less congestion on the primary route. The program also provides for improved incident response by personnel located in the Traffic Management Center (TranStar). A TxDOT demonstration project, conducted by TTI in 1991 (1) using cellular phones to provide traffic data, proved the viability of developing real-time information systems.

PROGRAM TECHNOLOGY

The RTIP utilizes an AVI system as one of the technologies for monitoring traffic conditions. AVI antennas and readers mounted on existing roadway structures monitor the passage of the vehicles equipped with transponder tags. A transponder tag, which is powered by a small battery, reflects encoded radio signals transmitted from the antennas/readers. The reflected signals are modified by the identification code of the tag so that the tag's information can be read by the antenna/reader system.

The antennas/readers are installed along the freeway, toll road, and HOVL system at approximately 5 kilometer intervals. Beginning stations on the radial freeways and tollroad are approximately 32 kilometers from the central business district (CBD). As a vehicle with a transponder tag attached to the windshield passes the antenna/reader stations, the antenna/reader activates (reads) the encoded message on the transponder tag. The message is transmitted over telephone lines to a computer in a traffic management center. The message identifies the transponder number, location of the reader, and time of day. As a vehicle passes successive AVI reader locations along a route, software determines accurate travel times and average speeds. System design requires field information be transmitted to the computer within one minute. This "real-time" information is then processed and formatted in tables and maps and is made available to the general public and appropriate transportation agencies.

TRAFFIC PROBES

A critical element in the development of the AVI project was the recruitment of 4,200 citizen volunteers to serve as traffic probes as they travel along the freeway, toll road, and HOVL system. By agreeing to place a transponder tag on the windshield of their vehicles, the volunteers provided the traffic data necessary for continuous updates of traffic conditions. The Phase 1 contract (I-45N, I-10W, US 290) provided for 1,000 tags and the Phase 2 contract (I-610, US 59, Hardy Toll Road, I-45S) provided for 3,200 tags.

Distribution of Transponder Tags

Recruitment of citizen volunteers to serve as traffic probes in the Real-Time Information Program proved to be difficult. The reluctance of citizens to place an electronic device on their vehicles was not expected by the study staff. The distribution of the 1,000 tags in Phase 1 was scheduled to coincide with the installation of the field equipment and be completed by the time the field equipment was operational. This was not accomplished. Only 600 tags had been distributed by the time the field testing phase began in October 1993. It was not until February 1994 that all 1,000 tags had been distributed. The 600 tags plus EZ tags did provide ample reads for the testing phase of the program. It required 14 months to distribute the 3,200 tags in Phase 2. The distribution of the tags was complicated by the effort to distribute the tags proportionally between the participating freeways in each phase.

Researchers sought to enlist volunteers to serve as traffic probes through:

- corresponding with large employers;
- seeking news media coverage;
- displaying changeable message signs and trailer message signs along freeways; and
- placing a notice on the Internet (World Wide Web).

Citizen Response

Individuals' concern that the transponder tag could be used to locate or trace their vehicles or that they would receive a speeding ticket in the mail was difficult to overcome. The ratio

between citizens contacted and citizens agreeing to participate was very poor. The most successful recruiting effort was the changeable message and trailer message signs along the freeways. The signs identified the study office telephone number, and this allowed researchers to talk directly with potential volunteers. This was time consuming, but did provide researchers with an opportunity to explain the program and assure individuals that the tag would only be used to monitor traffic on the freeways.

Citizens who could access the World Wide Web on their personal computers were very enthusiastic to volunteer. They could access the traffic map and see exactly what they were contributing to.

Tag Status

Participants reported 10 tags lost or stolen. There may be additional tags not in service caused by people that left town and did not return the tags or removed them from their vehicles for other reasons. An inventory will be made by study staff when all phases of the program have been implemented. At this time, the measure of the tags in service is the number of daily reads being attained. This read continues to be good.

EZ Tags

The ability to read the HCTRA EZ Tags when those vehicles are operating on the freeway system has greatly contributed to the success of the program. The study office did not contact the 50,000 plus EZ tag users directly to seek permission to read their tags in the Real-Time Information Program, but instead relied on the publicity generated by the news media. This resulted in several phone calls from EZ tag users expressing concern that their tags were being read without their permission. Researchers assured these individuals that their anonymity in our program was being protected by HCTRA. They were advised that if this explanation was not satisfactory, their tag number could be masked out of the program. To date, no EZ tag user has made this request.

Procedures for tag mail-outs, lost tags, and miscellaneous incidents with volunteers was covered in detail in the Annual Research Report (2) submitted to TxDOT in November 1995.

Probe/Tag Read Distribution

All Automatic Vehicle Identification (AVI) tags or toll tags that utilize the Amtech technology can be read in the Real-Time Information Program. The following agencies and private companies are represented in the program:

- HCTR–Harris County Toll Road Authority;
- HJBT–J.B. Hunt Trucking Company;
- MTRO–TxDOT tags on METRO buses;
- OTA–Oklahoma Turnpike Authority;
- OTHR–All other tags (approximately 20 sources); and
- TxDT–TxDOT tags excluding METRO buses.

The following tables identify the number of probes and reads for the week of July 15, 1996, for AVI Phases 1 and 2. Table 1 identifies the total number of probes by agency/company for the week. Table 2 identifies the total number of probes by freeway and agency/company for the week. Depending on trip length and direction, an individual probe can be identified on more than one freeway. Table 3 identifies the total number of tag reads by freeway and agency/company for the week. These reads reflect the number of reader stations that an individual probe passes on a trip.

Table 1. Number of Probes on All Freeways for Week: 07/15/96 to 07/19/96 (AVI Phase 1 and AVI Phase 2)							
FREEWAY	TAG TYPE						TOTAL
	HCTR	HJBT	MTRO	OTA	OTHR	TXDT	
Frequency	61,217	408	281	2,707	2,500	1,778	68,891
Percent	88.9%	0.6%	0.4%	3.9%	3.6%	2.6%	100%

PHASE	FREEWAY	TAG TYPE						TOTAL
		HCTR	HJBT	MTRO	OTA	OTHR	TXDT	
AVI PHASE 1	I-10 Katy Frequency	28,588	186	159	973	808	741	31,455
	US 290 NW Frequency	21,390	72	77	482	305	565	22,891
	I-45 North Frequency	23,677	205	98	1,389	769	608	26,746
AVI PHASE 2	US 59 Eastex Frequency	7,895	119	35	684	437	245	9,415
	Hardy Toll Frequency	18,837	14	4	219	98	239	19,411
	I-45 Gulf Frequency	11,615	31	68	344	303	571	12,932
	Loop 610 Frequency	37,292	338	163	1,691	1,658	1,226	42,368
	US 59 SW Frequency	25,021	85	113	521	453	874	27,067
	Beltway 8 Frequency	5,520	8	0	76	33	99	5,736

Tag Types:

- HCTR-Harris County Roll Road Authority
- HJBT-J.B. Hunt Trucking Company
- MTRO-TxDOT tags on METRO buses
- OTA-Oklahoma Turnpike Authority
- OTHR-All other tags
- TXDT-TxDOT tags excluding METRO buses

PHASE	FREEWAY	TAG TYPE						TOTAL
		HCTR	HJBT	MTRO	OTA	OTHR	TXDT	
AVI PHASE 1	I-10 Katy Frequency	216,405	1,272	5,076	5,137	2,788	6,661	237,309
	US 290 NW Frequency	220,380	407	2,179	2,571	1,003	8,785	235,325
	I-45 North Frequency	156,802	1,089	3,360	6,125	2,734	5,498	175,608
AVI PHASE 2	US 59 Eastex Frequency	49,403	483	965	3,225	1,173	2,086	57,335
	Hardy Toll Frequency	292,553	109	8	1,218	321	2,311	296,520
	I-45 Gulf Frequency	79,674	104	3,014	1,339	787	5,991	90,909
	Loop 610 Frequency	388,649	2,193	1,704	9,305	5,880	16,809	424,540
	US 59 SW Frequency	199,931	496	4,363	2,456	1,476	9,161	217,883
	Beltway 8 Frequency	12,147	8	0	96	38	184	12,472
TOTAL								1,747,901

Tag Types:

- HCTR-Harris County Roll Road Authority
- HJBT-J.B. Hunt Trucking Company
- MTRO-TxDOT tags on METRO buses
- OTA-Oklahoma Turnpike Authority
- OTHR-All other tags
- TXDT-TxDOT tags excluding METRO buses

The total number of probes from all sources for the week of July 15th was 68,891 which equals 1,747,901 total reads. This is an 85 percent increase in the number of probes and a 67 percent increase in total reads from the same period in 1995. This increase is directly attributed to the increase in EZ tags (HCTRA) operating on the freeway mainlanes.

The total reads of 1,747,901 provide a tag read rate of two to five reads per minute per station during the peak hours of freeway operation and a tag read rate of two to four reads per minute per station for off-peak hours of operation. This provides an excellent measure of the operating conditions of the freeway/toll road system and exceeds the project goal of one tag read per minute during the peak hours. The HOVLs are operating at one tag read per two to three minutes during their periods of operation. This is considered satisfactory because of the lanes' low volume and low congestion.

FUNDING

Funding for the five phases of the program involves both state and federal funds. Phase 1 used funds from the State Public Transportation Program. The use of these funds was justified because the freeways in Phase 1 included the HOVLs located in the center of the freeway mainlanes. The AVI system provides direct comparison of travel conditions on the two types of roadways. The availability of these funds accelerated the implementation of Phase 1. These funds were authorized by TxDOT Commission Minutes Number 91350, dated February 26, 1991.

II. SYSTEM DESIGN

GENERAL GUIDELINES

Project staff planned to develop a traffic monitoring system that could be quickly and easily implemented on the freeway, toll road, and HOVL system with minimum inconvenience to the motoring public.

Companies throughout the United States that provide AVI electronic detection systems were contacted. Researchers invited representatives to make presentations and provide material explaining their technology. TxDOT/TTI study staff established and presented the following installation and operational requirements to interested companies:

1. Antennas are to be installed above the traffic. An aboveground AVI system will utilize existing sign and roadway structures. Installation of in-pavement detection sensors is considered cost prohibitive because of the freeway lane closure requirements and resulting traffic congestion.
2. The system design must be capable of 95 percent accuracy. That is, 95 percent of vehicles equipped with transponders will be identified by the AVI system when operating at maximum freeway conditions of high volume and high speeds.
3. The system must be responsive. The system must have the capability to transmit field data to a traffic management center within one minute after the transponder has been read.

Because electronic monitoring of transportation is a relatively new science in this country, the TxDOT selection team felt that a company with longevity and a successful track record was a crucial element in the selection process. State law permits the selection of an equipment supplier (vendor) as sole provider on this type of project upon approval of the Department of Information Research Office in Austin. The contract to install the equipment must be awarded on the basis of competitive bidding.

After review and evaluation of the companies that presented their qualifications, the team selected the Amtech Systems Corporation technology for this project.

Amtech was selected because of its experience in implementation of similar systems in Texas, Oklahoma, and Louisiana with good reports from these locations. Critical to the selection was the use of Amtech technology by the Harris County Toll Road Authority (HCTRA) for their toll tag program and the planned use of Amtech technology by the City of Houston Aviation Department for traffic management at the two city airports. This compatibility of technologies has provided thousands of additional probe vehicles traveling the freeway mainlanes and HOVLS. As of September 1, 1996, over 90,000 toll tags had been issued by HCTRA.

Amtech's AVI system uses radio frequency identification (RFID) technology. The system consists of vehicle transponder tags, antennas, RF modules, and software. Transponder tags are small, battery powered, electronic devices that reflect and modify received continuous radio wave signals. Antennas broadcast and receive radio frequency signals generated by RF modules. Readers receive the signal from the antennas and RF modules, and transmit the data to a host computer located in a transportation management center. Leased telephone lines were selected to transmit the data because telephone communications provided flexibility of coverage on any freeway and allowed quick implementation of the program. To date, the use of telephone communication has been reliable.

The acceptance of Amtech as provider of the technology hardware was contingent upon its system meeting the outlined requirements in the testing phase of the contract. Amtech was responsible for providing the necessary computer software and field equipment to meet these requirements.

The computer system provided by Amtech is located in the TTI office at 701 North Post Oak Road. The Interim Central Control Facility (ICCF) operated from this location until January 1996. At that time the ICCF moved to and became part of the Houston TranStar Center at 6922 Old Katy Road. TranStar is the new multi-agency transportation and emergency management center for the greater Houston area. The AVI computer system will remain at the TTI office for two more years and then be transferred to TranStar.

FIELD INSTALLATION DESIGN

The freeway mainlane reader stations were mounted on roadway overpasses, overhead sign structures, and side-mount sign structures.

The roadway overpasses spanned the freeway mainlanes and permitted all three reader stations (inbound, outbound, and HOVL) to be mounted at one location. Figure 2 shows a typical roadway overpass utilized in this manner.

Overhead sign structures that span the freeway mainlanes were also used in this manner (Figure 3). Overhead sign structures that span one direction of the freeway mainlanes were used for mainlane directional reader stations (Figure 4).

The bi-directional reader stations for the HOVLs were mounted on roadway structures, overhead sign structures, overhead HOVL changeable message signs (CMS), and overhead HOVL lane signal structures. Figure 5 shows a CMS overhead structure used as a bi-directional reader station.

Side-mount sign structures were used for mainlane directional reader stations (Figure 6). The directional aim of the antennas at these stations was critical in order to get reads in all travel lanes (Figure 7).

ANTENNA DESIGN

In order to meet the read accuracy requirements of the program, Amtech Corporation used two types of antennas at the field read stations: the Yagi and Sinclair. Both types were used on the side-mount structure at North Shepherd (Figure 7). The Yagi is slenderer and longer in design than the Sinclair and is similar to a TV antenna. The Sinclair is a broader, encased type antenna.



Figure 2. TC Jester Overpass (I-10W)



Figure 3. Overhead Sign Structure East of W. 34th Street (US 290)



Figure 4. Overhead Sign Structure East of FM 1960 (US 290 WB Mainlanes)



Figure 5. HOVL Overhead CMS Structure (I-10 West of I-610)



Figure 6. Side-Mount Sign Structure at N. Shepherd (I-45 NB–Gulfbank Exit)

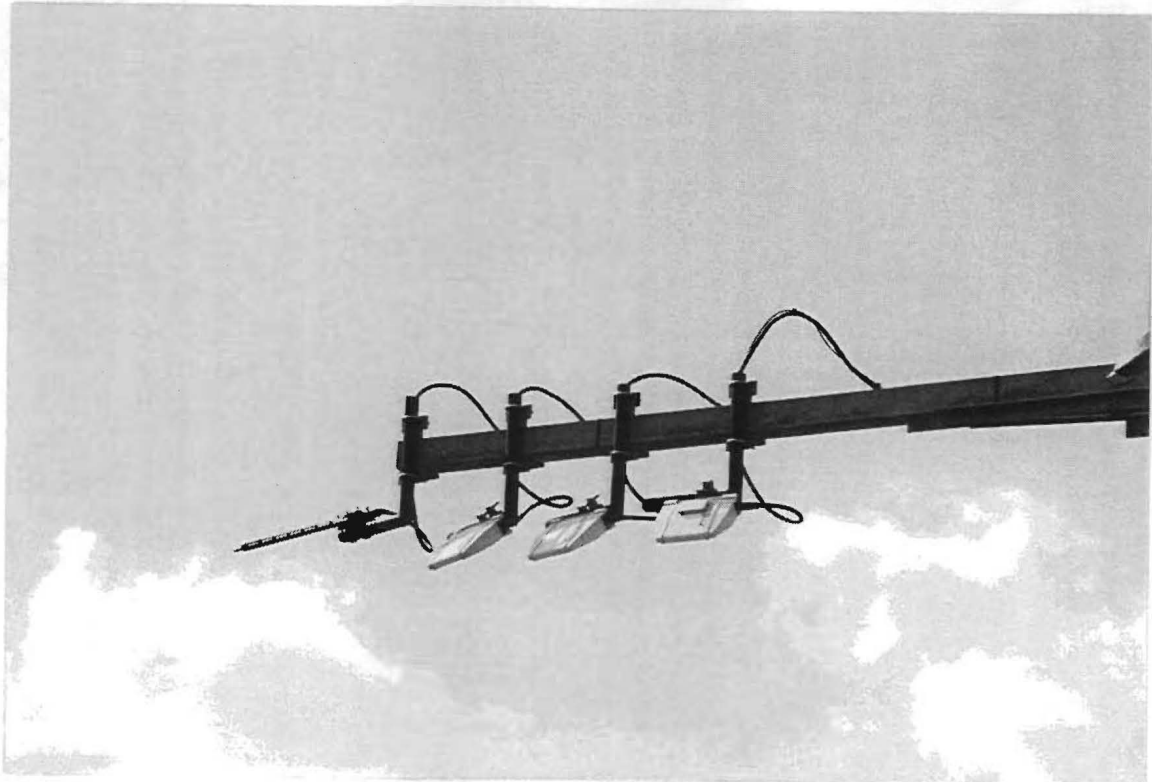

Figure 7. AVI Antennas at N. Shepherd Sign Structure

The physical description of the two antennas also suggests their operational capabilities. The Sinclair provides a broad, but shorter field read pattern. The Yagi is more directional and provides a narrow, but longer field read pattern. The Yagi was used to provide reads on the inside lane of the freeway mainlanes and on the HOVLS. The more narrow field read patterns at these locations prevented false reads from the adjacent lanes. This provided read accuracy for both the HOVLS and the freeway inside lanes. The read patterns for a typical field station are shown in Figure 8.

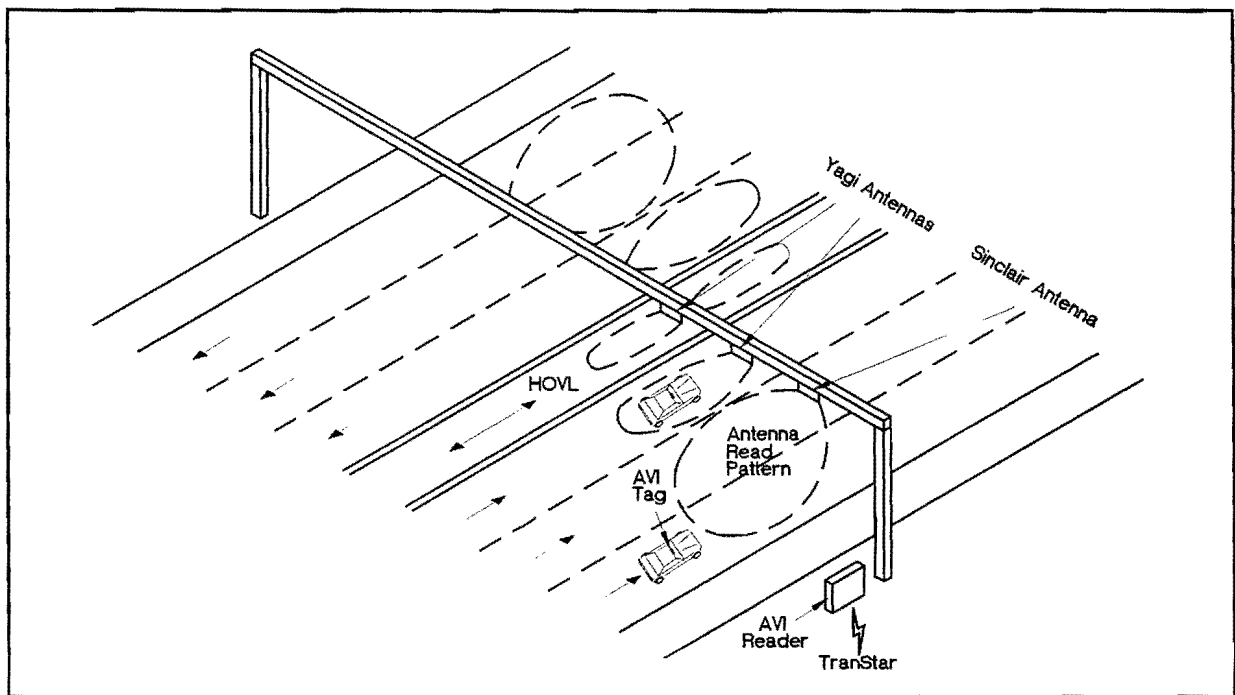

Figure 8. AVI Field Read Station

FREQUENCY OF PROBES

The AVI system is designed to sample travel conditions. Because of the time required to collect, process, and send AVI data over the leased telephone line, a one-minute interval was established as the goal for receiving updated information. During peak traffic on a four-lane freeway, one vehicle per minute with a transponder would represent less than 1 percent of the traffic volume. During daytime off-peak conditions, the percentage rises to 2 percent, and at nighttime, much higher. Operationally, the lower volume time periods are less important than the peak periods, so the time interval between tag reads can be longer.

The strategy with AVI Phase 1 was to target the distribution of TxDOT tags to users of the freeways and HOVLs during peak periods and to rely on tags distributed by toll roads and other agencies to supplement peak period coverage and to provide off-peak coverage.

Tag Reads and Freeway Traffic Volumes

In February 1995, three freeway locations were studied to determine the daily AVI coverage and the percentage of total vehicle volume on weekdays. The tag read rate (reads per minute) for peak (6:00 a.m.-9:00 a.m.) and off-peak (9:00 a.m.-4:00 p.m.) periods for each freeway location were determined. The results are shown in Table 4. In July 1996, the three locations were reexamined. These results are shown in Table 5. The freeway volumes shown are 24-hour volumes for one direction of traffic and includes the peak and off-peak period volumes.

Location	Freeway Volume	Tag Reads (Total)	Tag Read (Percent)	Data Point Tag Reads	Peak Hour Read Rate (read/min)	Off-Peak Hour Read Rate (read/min)
I-610 SB at Woodway	128,808	3,095	2.4%	1,857	2.6	2.3
I-10 EB at Dairy Ashford	65,253	2,021	3.1%	1,213	1.9	1.1
US 59 NB at Edloe	115,446	1,813	1.6%	1,088	1.3	1.2

Location	Freeway Volume	Tag Reads (Total)	Tag Read (Percent)	Data Point Tag Reads	Peak Hour Read Rate (read/min)	Off-Peak Hour Read Rate (read/min)
I-610 SB at Woodway	132,672*	5,802	4.4%	3,481	4.9	4.0
I-10 EB at Dairy Ashford	67,220*	4,247	6.3%	2,548	4.0	2.4
US 59 NB at Edloe	118,909*	3,213	2.8%	1,928	2.3	2.2

*Projected 3 percent volume increase over 1995 volumes.

For AVI monitoring systems to be successful, the transponder tags must be read by two successive reader stations in order to measure travel times and average speeds. Two successful reads is called a "data point." If the reader stations are located several miles apart with several entrances and exits in between, many tags will be used at either the upstream or downstream reader, but not at both due to traffic entering or leaving the freeway. Some tags may not be read because of system malfunctions (the design allows for errors of 5 percent). Some vehicles may exit the freeway and then reenter sometime later. This data is filtered from the system and is discarded. Therefore, the AVI system will have many more "tag reads" than "data points." In studies at the three locations, 40 percent of the tag reads were not matched to develop data points.

The "tag read rates" in reads per minute for both peak and off-peak periods are based on data point volumes. The results in February 1995 indicated that we were achieving the expected goal of 1.0 reads per minute on the average. There are times during the day when this is not achieved. To determine the impact of a larger distribution of tags by the Harris County Toll Road Authority, the study was repeated in 1996 with the expected results.

The study results indicate that the tag reads (traffic probes) are proportional to the traffic volume for each freeway and that the tag read percentage that has been attained and the resulting tag read rate provides an excellent measure of the traffic conditions on the freeway mainlanes. The tag read rates in Table 5 for the peak hours of freeway operation exceed the initial study goal of one read per minute on the high volume freeways.

FIELD TO CENTRAL COMMUNICATIONS

Amtech was responsible for designing and installing the system that communicates the tag read records from the field reader location to the central site. This required communications between the Auxiliary Data Processor (ADP) which initially creates the tag record and the AVI host computer at the central site (Figure 9).

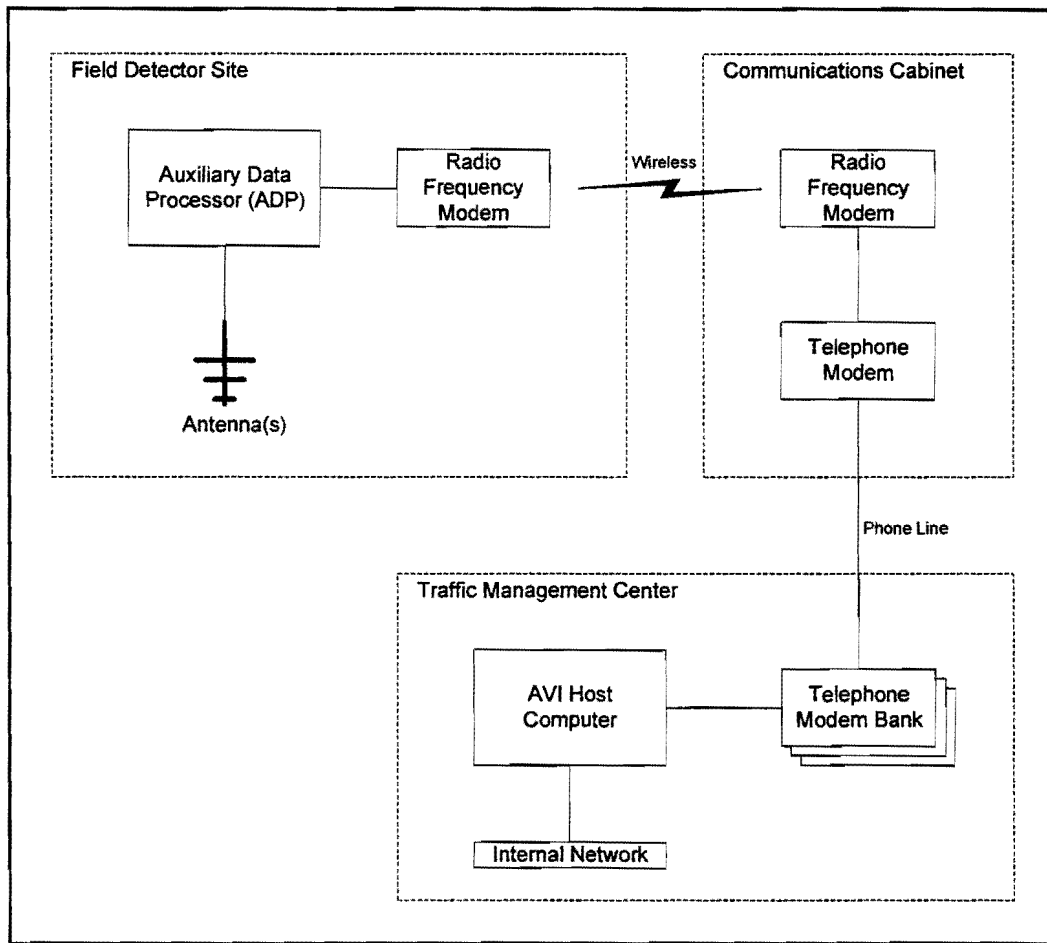

Figure 9. Field to Central Communications

Modem communication over the public switched telephone system (Southwestern Bell) is used for the primary link. Additionally, most locations use two wireless modems to communicate between the ADP which is located near the antennas and the telephone connection which is located off the right-of-way (Figure 10). The wireless connection saved installation costs by not requiring that telephone lines be installed across frontage roads.

The wireless connections use spread spectrum radio modems that do not require an FCC site license. These Proxlink brand modems provide a transparent wireless RS-232 link between the ADP and the telephone modem. These modems require line-of-site between the antennas of the two units and can operate at distances up to 1000 feet.

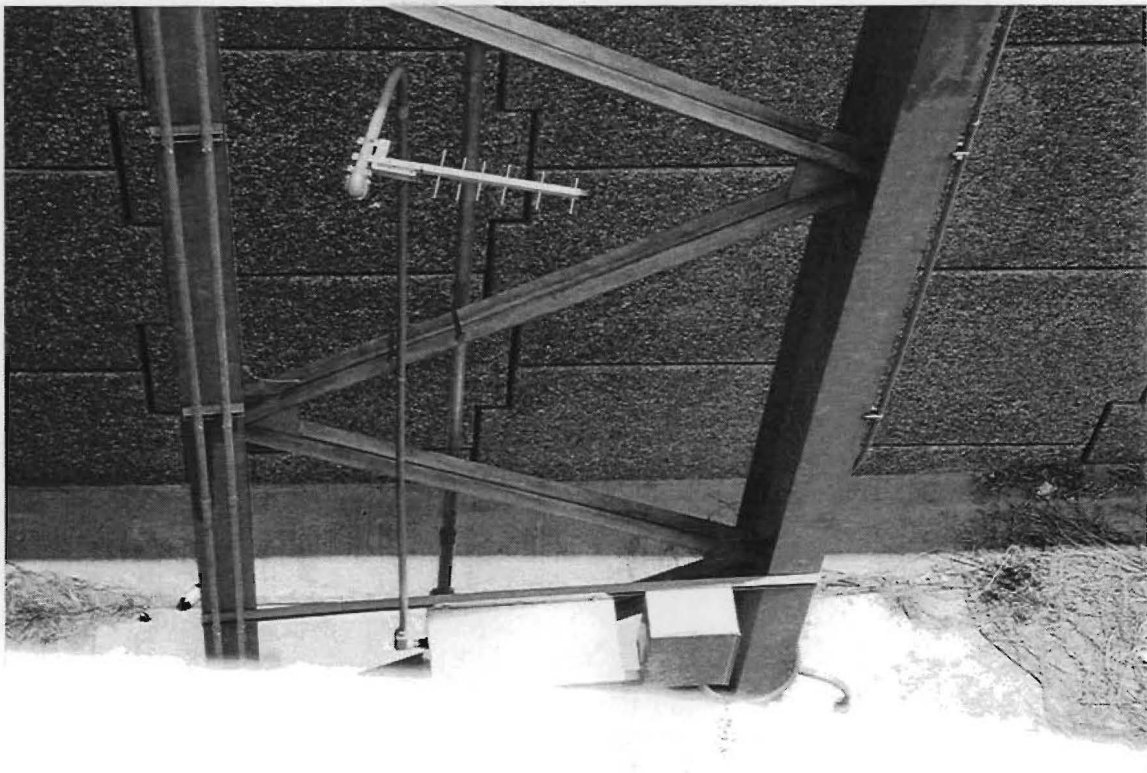
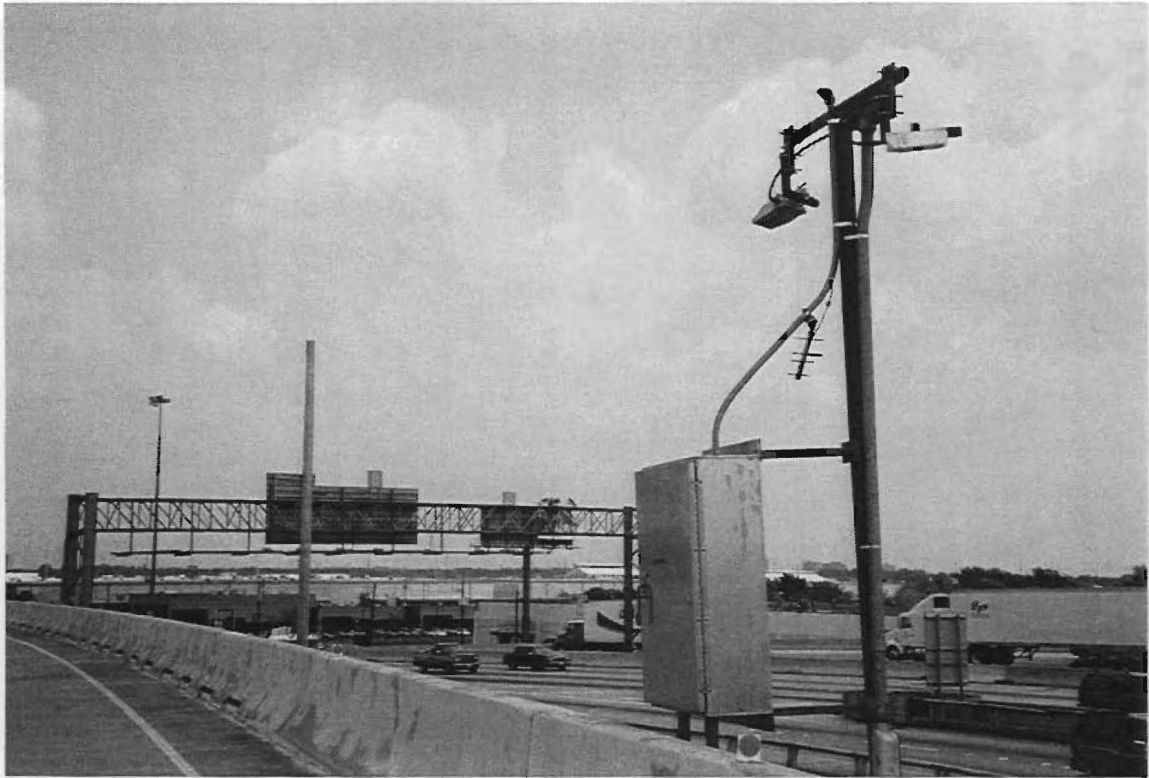

Figure 10. Wireless Modem Antennas

The telephone modem communications operate at 2400 bits per second. By utilizing data compression that is built into the modem, the modems actually operate at a bandwidth of 9600 bits per second. One telephone line was installed at each ADP. At the central site, approximately two modems were installed for every three ADPs in the field. These central modems are grouped into a pool of modems. All ADPs dial into a central number and are forwarded to the next available line in the pool. If all lines are in use, the ADP receives a busy signal and then re-dials. ADPs dial into the modem pool whenever a tag is read. The tag record, along with any other tag records that have collected during the time that the telephone connection is made, is sent to the AVI host computer. The ADP then hangs up the connection so the central line can be used by another ADP.

The specifications required that the system transmit tag reads to the AVI host computer within one minute of the time that they are read in the field. The majority of tag reads are actually received within 20 seconds. This is the time that it takes to dial, connect, and transmit the tag read to the host. If ADPs receive a busy signal, they must re-dial which adds to the time required to transmit the record. As the number of tags deployed in the system grows, the average time to transmit tag records must be monitored. If average transmission times grow too large, more modems may be added at the central site. To monitor these times, the AVIcalc software is used to periodically log the transmission time of each tag record to a file for analysis.

DATA PROCESSING SYSTEMS

Software Components

The AVI system uses various software elements to automatically gather tag data, compare tag data at successive reader locations to measure the progress of the probes along the roadways, and display the resulting data representing current travel conditions. Most software used in the system was developed specifically for use in this system, although it could be configured to work in similar AVI systems. TTI and Amtech developed separate software elements for TxDOT. Although the development tasks were segmented by function, coordination between Amtech and TTI was critical in developing software systems that correctly communicate system data. The following sections describe each software component's basic functionality. Figure 11 shows the data flow between each of these components.

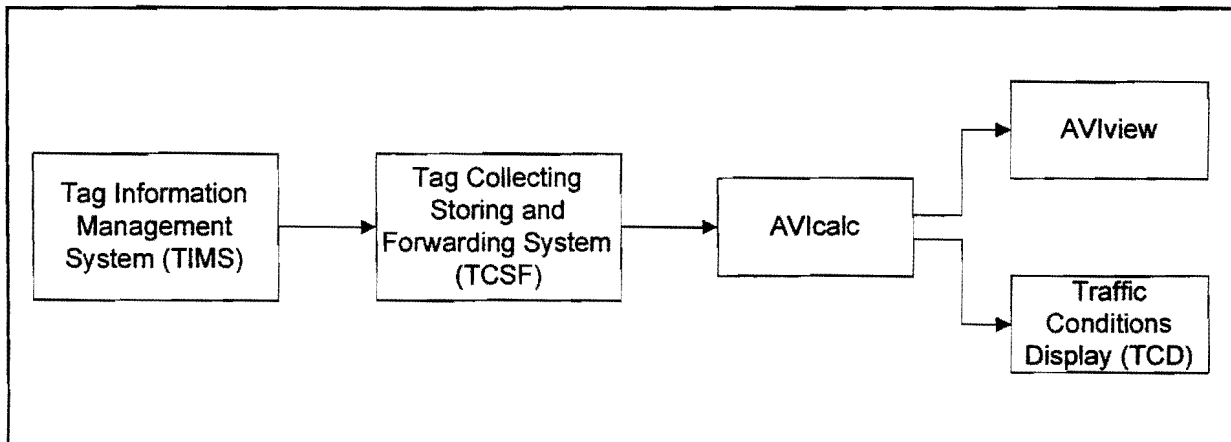

Figure 11. AVI System Data Flow

Tag Information Management System (TIMS)

At each tag reader station the ADP computer is used to recognize each tag, add a time and date stamp to the tag record, and communicate the record to the central site. Amtech used its existing Tag Information Management System (TIMS) software within the ADPs with minor changes. TIMS is the same software used in many of Amtech's automatic toll collection facilities.

Tag Collecting, Storing, and Forwarding System (TCSF)

Amtech was responsible for providing a system to bring each tag read record from the field reader stations to a centralized point and transfer the data to the TxDOT computer systems. The computer system responsible for performing these tasks is called the AVI host computer. This host computer is a Sun SPARCstation 20 running the Solaris (unix) operating system. This computer executes Amtech's Tag Collecting, Storing and Forwarding (TCSF) software package.

The TCSF software is responsible for processing and storing each tag read record as it is received from an ADPs. Tag information is stored within the AVI host computer within a local database as well as on shared disk drive storage. This storage of information on the shared disk enables data access by the AVIcalc program described in the next section. The TCSF software also monitors connections to the ADPs and issues status messages if communications are lost or error messages are received from an ADP.

AVIcalc

AVIcalc is responsible for receiving tag read data from the AVI host computer (described above), processing the data to produce vehicle travel times, identifying and discarding any “bad” or “invalid” data, and forwarding this information to the AVIview programs for display.

Each time a probe vehicle passes a checkpoint in the system, a tag record is produced. Each tag record consists of the tag’s identification number, the identification number of the antenna that detected the tag, and the exact date and time the tag was detected. As tag records are received from the AVI host computer, AVIcalc searches through older tag records to find when the vehicle passed the previous checkpoint. The travel time of the vehicle is calculated by determining the difference between the two tag record time stamps.

AVIcalc calculates a vehicle’s average speed by dividing the measured travel time into the known distance between checkpoints. The travel time and speed data are stored in a data file on the network from which the AVIview software (described below) accesses the data for viewing. Since April 1996, AVIcalc has also stored the speed and travel time data in an Oracle relational database management system within the Houston TranStar Center. This allows the TranStar Traffic Conditions Display (described below) access to the data.

Invalid Data Screening Algorithm

One inherent problem with using AVI systems to collect travel time data is the possibility of collecting invalid data. If a probe vehicle passes a checkpoint, then stops or takes a detour before passing the next checkpoint, a travel time that is longer than the expected travel time will be reported. An algorithm is used within AVIcalc to attempt to identify this invalid data. This algorithm will only work if there are vehicles with tags traveling the section so that there will be current data to compare. The algorithm has proven successful in screening out most invalid data, given the large amount of data collected by the system. The technique and algorithm are described below.

Assume that two vehicles traveling on a section of roadway at the same time will always travel at the same speed and that no speeds are too fast. Given this, if vehicle A and vehicle B start

at the same time and vehicle B finishes after vehicle A then vehicle B had to have gotten off the roadway or stopped for some period of time. Of course, we know that the two vehicles will not travel at the exact same speed, so a time buffer is introduced which will allow for the difference in their speeds. The minimum and maximum speeds of the vehicles are estimated from current conditions. From these minimum and maximum speeds, minimum and maximum travel times are calculated. The difference between these travel times should be the maximum amount of time variation between two vehicles traveling the roadway segment at the same time. If the travel time difference between vehicle A and vehicle B is greater than this buffer, then the data from vehicle B is considered invalid.

The following is the algorithm used to implement this technique using a buffer of ± 20 percent.

```

get next data record (called match1)
match2 is a previous data record for the section of roadway
if (StartTime1 < StartTime2) and (EndTime1 > EndTime2) then
  begin
    TimeDif = (StartTime2 - StartTime1) + (EndTime1 - EndTime2)
    MinSpeed = 0.80 * CurrentSpeed;
    MaxSpeed = 1.20 * CurrentSpeed;
    MinTravelTime = (Dist / MaxSpeed) * 3600;
    MaxTravelTime = (Dist / MinSpeed) * 3600;
    TimeBuffer = MaxTravelTime - MinTravelTime;
    if (TimeDif > TimeBuffer) then
      read 1 is invalid
    end
  end

```

Variable Descriptions

StartTime - time that the first checkpoint was passed
 EndTime - time that the second checkpoint was passed
 TimeDif - total travel time difference between vehicle1 and vehicle2
 CurrentSpeed - current speed on roadway (from current AVI data)
 MinSpeed - estimated minimum speed on roadway segment
 MaxSpeed - estimated maximum speed on roadway segment
 Dist - distance of current roadway segment
 MinTravelTime - estimated minimum travel time on roadway segment
 MaxTravelTime - estimated maximum travel time on roadway segment
 TimeBuffer - estimated maximum allowable travel time difference between vehicle1 and vehicle2

AVIview

The AVIview program(s) takes the travel time information provided by the AVIcalc program and presents the information to a user in two formats. Data are shown in data tables that present travel times, speeds, and a historical plot of data by roadway section. A color-coded map

of Houston area freeways presents average speeds by section for quick identification of travel conditions.

A sample map image is shown in Figure 12. The map display uses six different colors to identify speed ranges. The display shows speeds in both freeway directions as well as on the HOV lane. The two outer lines represent the freeway lanes in each direction. If three lines are present for a roadway, the middle line represents the HOV lane. Data for the HOV lane changes direction as the HOV lane operation changes direction. Roadway segments are marked as "Not Available" using a gray line if no information has been collected in the past 30 minutes.

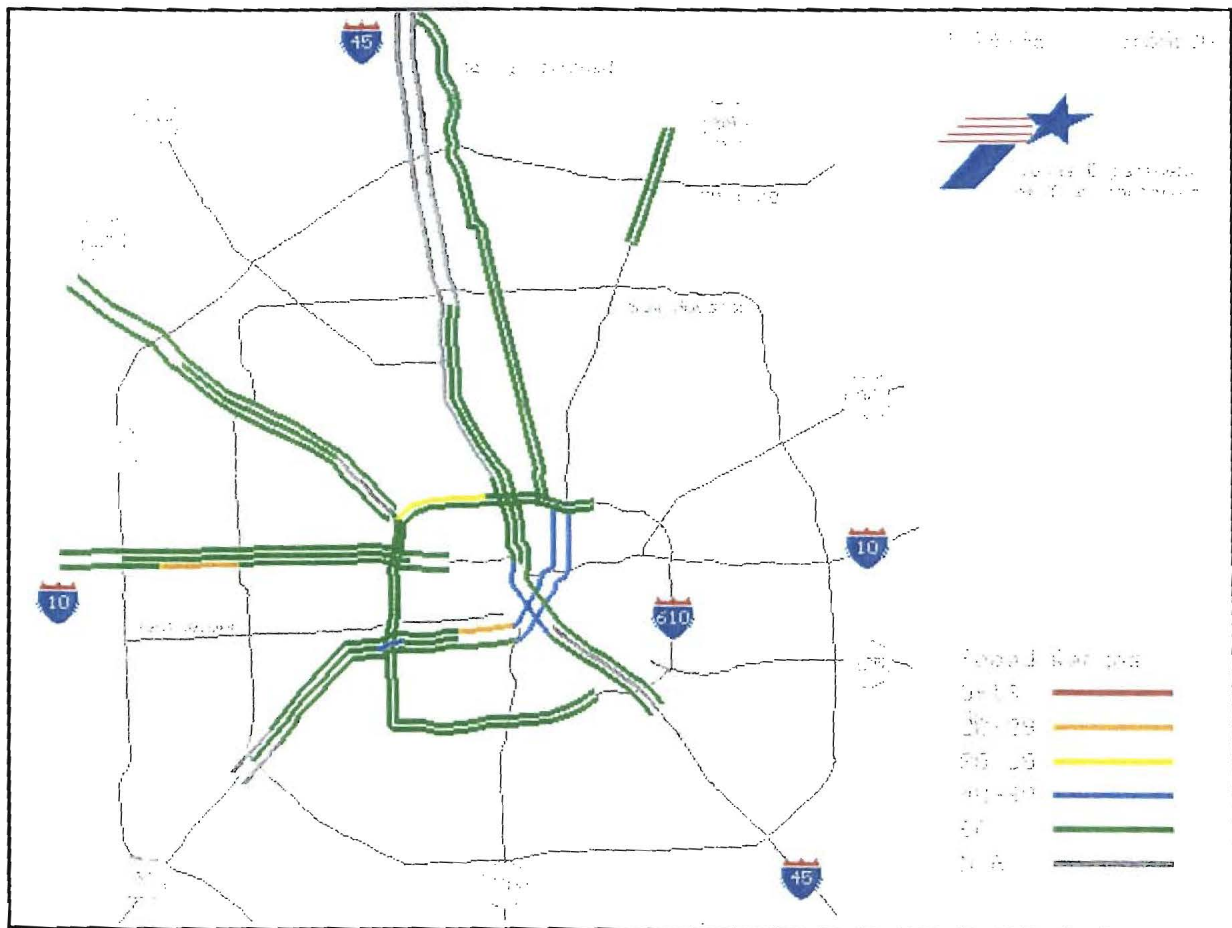

Figure 12. Sample Color-Coded Map Image

Traffic Conditions Display (TCD)

The Traffic Conditions Display (TCD) is a multi-purpose mapping system developed for the Houston TranStar Center by Lockheed Martin (formerly Loral Space Information Systems). The

The TCD allows traffic operators within TranStar to view travel data including the AVI data and loop detector data using a color-coded display similar to that of AVIview. The TCD also shows locations of various TranStar devices including cameras, changeable message signs, and lane control signals.

Original System Architecture

In the original system design, the AVIcalc program executed on a single IBM compatible 386DX computer connected to a Novell Netware 3.11 network. AVIcalc received information from the AVI host computer through a shared file which was accessed through the Novell Netware file server. This access was made possible by connecting the AVI host computer to the Novell Netware server using a software package called Netware NFS Gateway which allows computers connected to the Novell file server to access files on the AVI host computer.

The Netware network was also used to transmit the travel time information from the AVIcalc computer to the AVIview programs using a shared file on the Netware server. AVIview was a DOS based program which could execute on personal computers with at least a 386 processor. Figure 13 shows the network configuration and data flow of the original system.

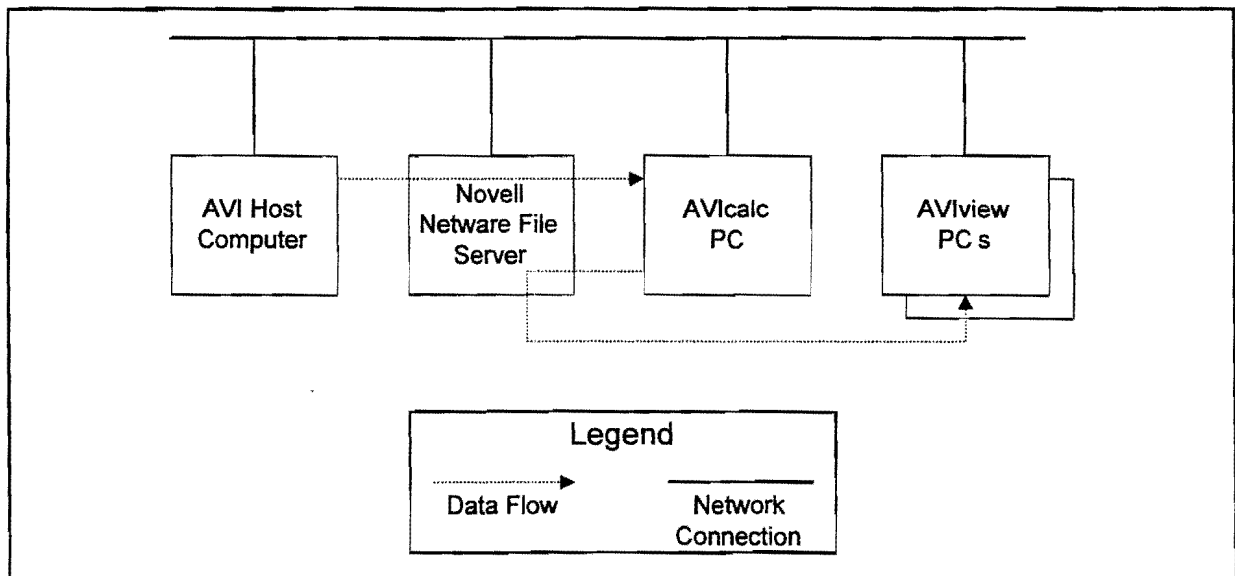

Figure 13. Original Network Setup and Data Flow

Current System Architecture

With the development of the Houston TranStar Center, there was a need to integrate the AVI system into the Houston TranStar systems which use an Oracle relational database management system instead of files to store and manage the real-time data. Utilizing this database would make sharing and management of the data much easier. TranStar includes an Integrated Traffic Management (ITM) server which is a Hewlett-Packard brand server running the HP-UX (unix) operating system. The AVIcalc program was modified to execute on the ITM server and store the travel time and speed data into the Oracle database, which also contains the general configuration data about the AVI checkpoints and roadway segments for access by AVIcalc. Software forms were developed for entering, deleting, and modifying this configuration data.

A Network File System (NFS) connection is used to transmit the raw AVI tag read records from the AVI host computer to the ITM server where AVIcalc processes the information. Figure 14 shows the network configuration and data flow of the current system.

To allow TranStar operators to execute the AVIview software on the operator consoles, AVIview is currently being modified to execute as a Windows program. AVIview will be used in the future (primarily for the AVI Phase 4 project) to provide additional displays of the AVI data.

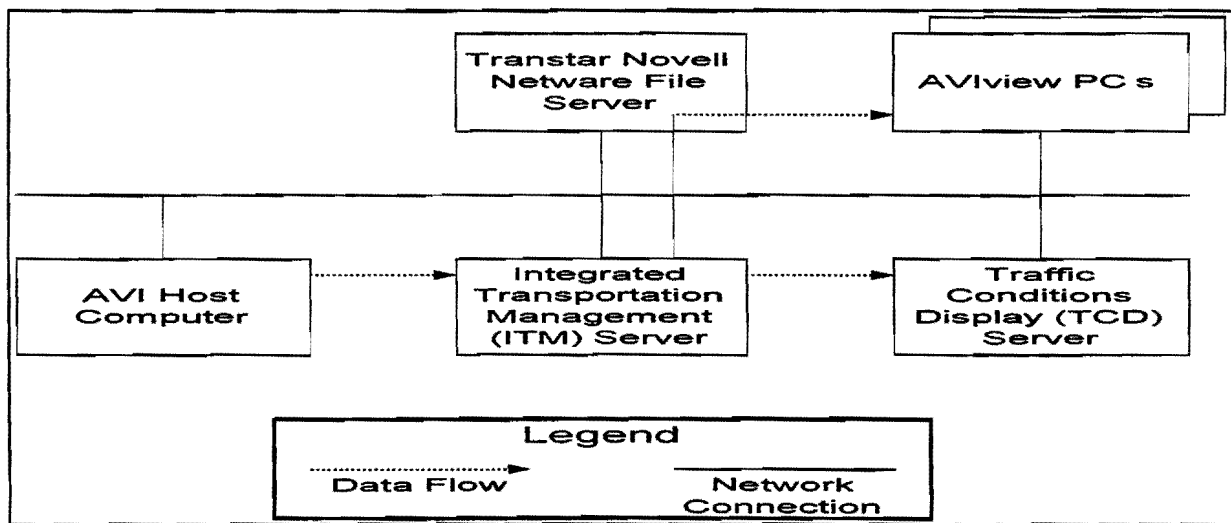

Figure 14. Current Network Setup and Data Flow

III. SYSTEM OPERATIONS

GENERAL OPERATION

The AVI system requires a limited amount of daily system operation. Some areas, though, need regular attention.

TxDOT personnel at TranStar are responsible for keeping the AVIcalc software operational on the ITM server at TranStar. Normally, AVIcalc executes continuously on the ITM server with no need for operator interaction. Error and warning messages are stored in a common status log in the TranStar database. TxDOT personnel monitor this log for AVI and other messages that may need attention. TTI personnel are also on call to assist TxDOT personnel in solving problems that may occur.

TTI is responsible for the management and archival of all data collected by the AVI system. Each night at midnight, the AVIcalc program archives the raw data that has been collected that day. The data is then transmitted to a data management computer at TTI. An automated program on this computer calculates summary statistics and archives the raw data and summary data to long-term magnetic tape storage.

TTI personnel are also responsible for monitoring the AVI system for malfunctions of field and computer equipment detected at the central site. In addition, Amtech maintenance personnel monitor these malfunction reports and are responsible for correcting the problems. Amtech is required to correct any problem within 24 hours. If field equipment malfunctions are not corrected, the Amtech Response Center is contacted for an explanation. Most malfunctions have dealt with communications, although there have been instances of equipment damage due to rain and vehicle accidents.

INFORMATION DISTRIBUTION

Houston TranStar

Travel time and speed information collected by the AVI system is provided, in real time, to personnel within the Houston TranStar Center (Figure 15). TranStar personnel in the control center (Figure 16) have access to the AVI data through the Traffic Conditions Display (TCD) on individual operator consoles. A computer with a high resolution 37-inch monitor that provides a continuous display of the AVI map is installed in the control center. This display provides quick viewing by control center personnel. Personnel throughout the TranStar Center can access the AVI data, by personal computer, using the AVIview program provided by TranStar's Novell Netware Network.

Internet

In December of 1994, TTI developed a system which provides the AVI map display and data reports to the public through the World Wide Web portion of the Internet, the international network of computers. The site allows commuters with Internet access to view travel information at work or at home to better plan their commute. Data on the site is updated once every minute so that people get a current view of traffic conditions. The site includes a general description of the AVI system design and operation. This allows commuters and other transportation agencies around the world to learn about Houston's AVI system.

TTI's Internet server at address <http://traffic.tamu.edu/traffic.html> is used to serve out the AVI map. This site has been one of the most popular Internet sites in the Houston Area. A front page article on the site was published in the Houston Chronicle on March 10, 1995, and the site has been featured in numerous local television news reports. The number of users of the site has steadily grown during the past year: 7,000 monthly users in August 1995 to over 10,000 in May 1996.

The system provides four views of the AVI data. The primary view is the color-coded map display, previously shown in Figure 12. The AVIview program is used to create this map and is the same map seen by TranStar personnel using the AVIview program.



Figure 15. Houston TranStar



Figure 16. Control Center

Three additional features are included which allow the user to access more detailed information about roadway segments. The 'clickable map' feature allows the user to select a specific roadway segment on the map display with their mouse. The system then provides them with detailed information about the roadway segment including the roadway name, the beginning and ending cross street names, the length of the segment and the last collected travel time and average speed. A sample of this information is shown in Figure 17.

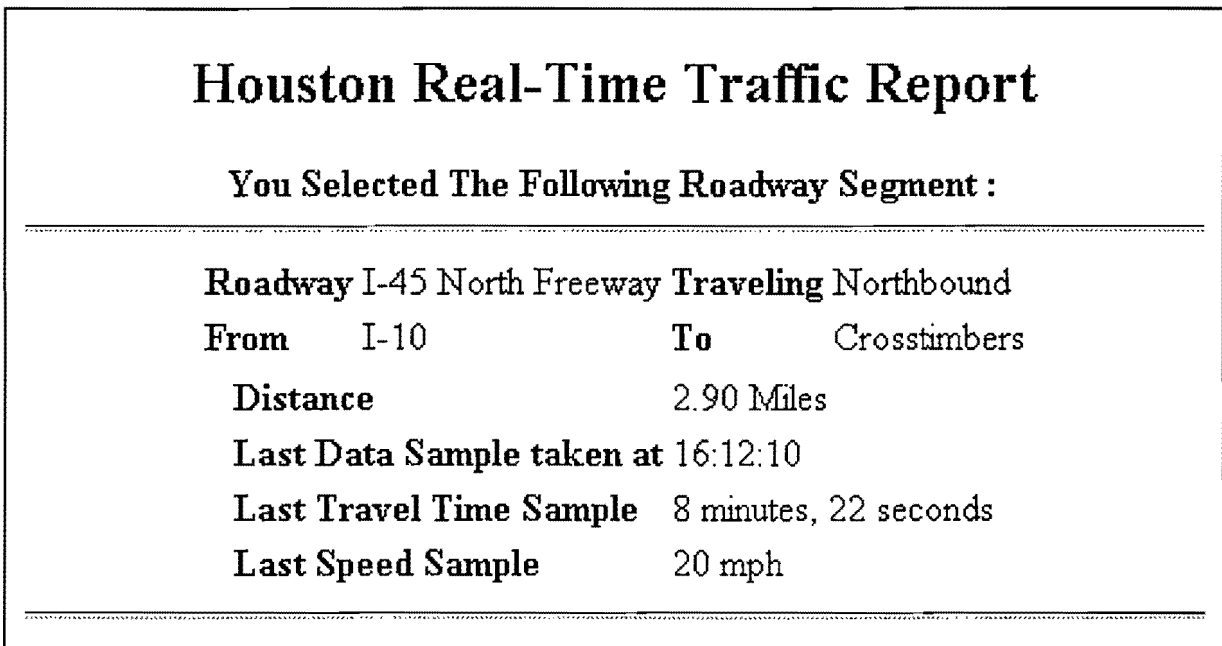

Figure 17. Sample Segment Data Report

Another feature allows the user to view the detailed information in tabular format for a complete freeway which allows users to view travel time and distance information for a complete freeway so they can better plan the length of an upcoming trip. A sample of this information is shown in Figure 18. The far right column shows a graphic which is color-coded based on the speed using the same legend as the color-coded map image (Figure 12). This allows users to quickly locate problem areas.

I-45 Gulf Detailed Data						
Freeway Northbound						
From	To	Data Age	Dist (miles)	Travel Time	Speed (mph)	
Broadway	Woodridge	16:10:30	1.30	1:17	60	●
Woodridge	Wayside	16:12:04	1.60	1:35	60	●
Wayside	Scott Street	16:12:43	2.55	6:12	24	●
Scott Street	I-10	16:12:00	4.20	7:56	31	●

Figure 18. Sample Tabular Data Report

The detailed information, along with a description of how the system works, may help users better understand the type of data that the system collects, thus allowing them to better interpret the information.

The latest feature added to the Internet system is the Route Builder Utility. This utility lets Internet users define a route from one point in the freeway system to another using the AVI checkpoints to define the route. As users define the route, they are shown a travel report for the sections of the route and the total route. To implement the Route Builder Utility, special pairings of checkpoints were defined for the AVIcalc software to time vehicles between. These new pairs allow AVIcalc to calculate travel times of vehicles who exit from one freeway to another freeway. For example, the report in Figure 19 shows a route which proceeds northbound on the I-610 West Loop, then takes US 290 westbound.

Public Displays

Government employees and visitors may view the travel information at several remote kiosk-type displays that have been installed in the lobby areas of county, city, and TxDOT offices in Houston. The computer displays show the AVI map display for commuters as they leave the workplace.

Sensor Locations	Last Data Time	Dist. (miles)	Travel Time	Speed (mph)
I-610 West Loop Freeway, Northbound				
US-59 Southwest				
Westheimer	11:36	0.90	0:53	61
Woodway	11:36	1.80	1:50	58
I-10 Katy Freeway	11:36	1.65	1:41	58
US-290 Northwest Freeway, Westbound				
Dacoma	11:36	1.25	1:10	64
34th Street	11:35	1.10	1:06	60
Pinemont	11:36	2.45	2:20	63
Fairbanks	11:35	2.90	2:43	64
Sam Houston Tlwy	11:35	1.55	1:28	63
Route Totals :		13.60	13:11	62

Figure 19. Route Builder Report

Smart Commuter Information Delivery System

The TranStar Smart Commuter Information Delivery System (CIDS) is a Federal Highway Administration (FHWA) Sponsored Field Operational Test which will disseminate real-time traffic, and static bus schedule information to 700 commuters in the I-45 North Freeway Corridor. The participants will be provided the information using two methods: (1) an interactive telephone system (ITS) to hear the information, and (2) a portable Personal Digital Assistant (PDA) to view the information. The project is being used to evaluate the usefulness of this information in affecting commuters' driving habits, with emphasis on converting commuters to carpooling and transit.

The AVI system is the main traffic data source for the CIDS. TRW is under contract by the Metropolitan Transit Authority of Houston (METRO) to develop the computer and communication systems to provide the data to the participants. The CIDS accesses updated AVI data from the TranStar Oracle database once every 10 seconds. This data is then made available to the ITS and PDAs. When users access the ITS, they can hear voice reports of current travel times along various routes in the corridor including I-45 North Freeway and HOV and an alternate route of the Hardy Toll Road. On the PDAs, users may view the travel times as heard on the ITS and may also view a map of the corridor which shows icons representing current roadway conditions.

Cable Access Channel

Plans are currently underway to develop a system to show the AVIview map display on the City of Houston Municipal Channel. This television channel, which is available through most Houston area cable television services, will display the travel speed map at timed intervals during peak travel hours. Persons with access to the channel can check roadway conditions before beginning their commute trip.

The system will use a remote display similar to the public displays described above at the Municipal Channel office to create the map display. A scan converter device will convert the computer graphic image to a TV signal for broadcast by the channel.

Houston Traffic/Transit Kiosk Information System

Houston TranStar is pursuing a Priority Corridor project that will develop and install 10 publicly accessible kiosks throughout Houston. Each kiosk system will use the AVI data to present the user with a color-coded map of freeway speeds. The kiosks will also show general information about Houston TranStar, METRO bus route information, and incident and construction conditions.

Metro SmartCar

TTI is conducting a project for the Metropolitan Transit Authority of Houston (METRO) to equip one or more METRO police cars with computer and communications systems that provide the officer access to information collected by the Houston TranStar Center. One of the main capabilities of this system will be the AVI map display on the computer screen within the vehicle. The officer will use the information to determine problem areas and the best route to approach any destination.

SYSTEM MODIFICATIONS

TranStar Communications

The Houston TranStar Center became operational during the spring of 1996. The original plan was to move the AVI system operations from the TTI offices at 701 N. Post Oak into the TranStar Center. However, the cost of moving the communications telephone lines to TranStar was greater than anticipated because the "Centrex" system used for the central phone lines would not be available at TranStar. Changes in the Texas tariff laws allowed telephone companies to stop providing this low-cost billing package to customers. Customers may keep and add lines to their existing system, but may not purchase a new system and may not move an existing system unless in the same central switching office. Unfortunately, even though the TranStar and TTI offices are only 2 kilometers apart, they are in different Southwestern Bell telephone offices.

If the change was made from the Centrex system to regular business rate telephone lines at \$40 per line per month at TranStar, the communication costs for the central site would increase by \$25,000 per year to operate Phases 1, 2, 3, and 4. It was decided that this system would stay at the TTI office site and an existing fiber-optic cable would be used to transmit the data to TranStar. This fiber link was made operational in March of 1996. Ultimately, the system will be moved to TranStar when other communications options become available.

Communication Migration

Currently, 35 of the 88 sites in Phases 1 and 2 are on roadways that have TxDOT owned fiber-optic communications. These sites could be moved to fiber-optic communications which would remove 35 field telephone lines and 23 central telephone lines from the system and result in a savings of approximately \$24,000 per year. To accomplish this change, a project would be developed to acquire the necessary equipment and to make the necessary installation. Changes in Amtech's TIMS software and TCSF software packages may also be required. No cost estimates for this work have been developed at this time.

INSTALLATION COSTS

Field Installation Cost

Table 6 identifies the total field installation cost for Phase 1, along with the number of reader stations, average cost per station, and average cost per freeway centerline kilometer. The contract to install the field equipment was let in July 1993. Field tests began in October 1993. The system was operational on all three freeways (I-45N, I-10W, US 290) by January 1994.

Total Cost	\$1,731,470
Freeway One Direction Reader Stations	40
HOVL Bi-Direction Reader Stations	15
Total Reader Stations	55
Average Cost Per Reader Station	\$31,481
Freeway Centerline (kilometers)	91.2
Cost Per Kilometer	\$18,985
Average Distance Between Stations (kilometers)	5.2

OPERATIONS/MAINTENANCE COSTS

Communications Cost

The cost of telephone lines for the system is a major operational cost of the system. The cost of maintaining the 164 telephone lines for Phase 1 and Phase 2 combined is approximately \$65,000 per year, which is approximately \$40 per month per line for field lines and \$25 per month per line for office lines.

One telephone line is needed for each Auxiliary Data Processor in the field and approximately two telephone lines are needed at the central site for every three ADPs in the field.

Some sites which would normally incur long distance charges for calls to the central site, were priced at a higher rate allowing them to make the calls as local calls.

Since the central telephone lines were all at one location, they could be provided as part of a "Centrex" system which averages about \$25 per month per line. This saves greatly in the cost of the central telephone lines. Table 7 shows the current monthly operational costs for both the Phase 1 and Phase 2 AVI projects.

Table 7. Telephone Communication Costs				
	Phase 1		Phase 2	
	Number of Lines	Cost	Number of Lines	Cost
Central Lines	*46	\$1,125	30	\$ 765
Field Lines	36	\$1,535	52	\$1,940
Monthly Total	82	\$2,660	82	\$2,705

*Sixteen of these lines are used for non-tag communication purposes (networking and dial-in data access).

The current configuration with all four AVI phases implemented will require approximately 200 telephone lines at an annual cost of \$96,000. Overhead charges increase this to \$129,600 per year.

Staffing Requirements

Minimum staffing requirements are based on 0.25 man years and provide the following services:

- Computer support staff (daily monitoring of system);
- Coordination of maintenance activities;
- Maintenance of database; and
- Administration of AVI accounts.

Estimated annual salary cost for this activity is \$12,800 and includes a 60 percent overhead and fringe benefit factor. This estimate accommodates all four phases of the project.

Staffing requirements to provide enhancements to the system are based on 0.25 to 0.50 man years and would provide the following additional services:

- Develop software modifications to enhance the system operations;
- Expand the dissemination of information by coordinating applications of the database;
- Promote the use of AVI in other transportation management applications; and
- Investigate modifications in hardware and software designs for extended use of the AVI system.

Estimated annual salary cost for this enhanced operation is \$30,400 and includes the 60 percent overhead factor.

Estimated clerical support staff is 0.10 man years at an annual cost of \$3,200 with the overhead factor. This estimate applies to both the minimum and enhanced staffing cost estimates.

The total estimated salary cost for a minimum staffing operation is \$16,000 per year. The total estimated salary cost that would also provide system enhancement programs is \$46,400 per year.

Total Operations Cost

The total estimated operations cost for all four phases of the program is \$176,000 per year. This is based on accounting procedures and rates used by TTI for contracts with TxDOT.

Maintenance Cost

The current maintenance agreement between TTI and Amtech has a monthly charge of \$133 per AVI station. With the completion of the installation of Phases 3 and 4, the total number of stations in the system will be 167 for an annual cost of \$266,537.

The annual maintenance contract for the computer system for Phases 1 and 2 is approximately \$1,500. For the total system, the annual cost is expected to be approximately \$2,500.

Total annual maintenance cost for all four AVI phases is \$269,037.

Total Annual Operating and Maintenance Cost for AVI

Based on the current design and maintenance agreements, the total annual operating and maintenance cost for the AVI system will be approximately \$445,037. The total cost of installation for the four phases is \$8.44 million. Therefore, the annual operating and maintenance cost represents approximately 5.27 percent of the estimated installation cost.

Summary

As noted in the staffing discussion, \$30,000 is designated for improvement and enhancements to the system. These may be deleted from the analysis of requirements for operating the existing AVI system.

Communications cost of \$96,000 is based on 200 leased telephone lines. Studies will be conducted on alternative forms of communication, such as connection to the TxDOT or RCTSS communication network and wireless communications. Also, an analysis on modifications to the AVI design which would reduce the communications cost will be conducted, such as reducing the number of receiving lines in the central office, storing more data at the field sites before initiating

calls, collecting data from AVI stations at communication hubs for transmission to the central computer, and polling sites versus field site initiated calls.

The major cost is the maintenance of the field sites. TxDOT has a negotiated contract with Amtech to maintain all of the field equipment. The cost is based on a standard charge per month for each field station. An examination of the maintenance records may determine if there is a more cost efficient method of contracting for this service. The use of TxDOT technicians will be considered. This may be an important factor because of the large area over which the AVI is installed. Much of the maintenance cost can be attributed to the time required to travel to each of the sites.

Although the annual maintenance cost is only approximately 5 percent of installation costs, which would appear to be in line with other similar types of electronic systems, there are three things to consider: 1) more than half of the cost of the systems was construction costs, which had some traffic handling costs; 2) approximately \$175,000 of the costs were for transponder tags, which are not included in the maintenance costs; and 3) each AVI site is equipped with essentially the same electronic devices, so that the technical requirements for troubleshooting and repairs are simplified.

Finally, it should be noted that TxDOT has been supporting the operation and evaluation of the AVI systems as they have been developed and implemented over the last four years. The level of support have been approximately \$250,000 per year. The funding sources for this support have been varied, including 100 percent state funds for Phase 1, CMAQ funds for Phases 2 and 3, and Priority Corridor Funds for Phase 4. TxDOT has also committed state funds to the maintenance of the field equipment.

IV. CLOSURE

SUMMARY

Implementation of the AVI traffic monitoring system presented several challenges, the foremost being to select a technology that would provide a reliable measure of the traffic flow on the freeway/toll road/HOVL system at a reasonable cost. To date, Amtech Corporation's technology is providing this reliability. The 95 percent read accuracy requirement is being met as reflected by the tag read rates of two to five reads per minute in the peak hours of operation and two to four reads per minute during the off-peak periods. The cost of \$19,455 per centerline kilometer for Phase 1 is considered a relatively low cost for a traffic management system.

Reader stations were placed on existing roadway bridges, overhead, and side-mount sign structures, therefore, it was not necessary to erect any separate reader station structures. Enough existing structures were in place to meet the project goal of 4-5 kilometer station spacings.

The existing structures served as platforms for AVI antennas and supports for equipment cabinets. Antennas were mounted with adjustable brackets to achieve maximum reception and read accuracy.

The communication system utilizes leased telephone lines to transmit the message (reads) from the reader stations to TranStar. The communication from the reader station equipment cabinet to the telephone service drop is provided by wireless modems at most locations. This provided a cost savings in lieu of placing conduit under freeway service roads. Conversion of the lease line to fiber-optic communications is an option to be considered in the future.

The reluctance of the general public to serve as traffic probes was surprising. The concerns that the transponder tag would be used for law enforcement or that their vehicles could be traced were difficult to overcome. Project staff had to continually explain how this information cannot and will not be used for that purpose.

The technology compatibility with the Harris County Toll Road Authority's (HCTRA) EZ tag toll collection program has been the major contributing factor in the increase of total reads and read rates on the freeway mainlanes. The issuance of EZ tags by HCTRA has more than doubled (40,000 to 90,000) since the AVI program began in 1993. As the toll road system expands and more EZ tags are issued, the combination toll road and freeway trips by the EZ tag user may preclude the need for the issuances by TxDOT of tags for traffic monitoring functions only.

BENEFITS

Benefits of the AVI system are difficult to measure directly because the purpose is to provide information to the public by which they can make decisions as to the trip route or the time to start their trips. The AVI system demonstrates that it can be a good source of information about the location of problems such as stalled vehicles and accidents that cause slow speeds. Early detection of these events can save hundreds of hours of travel time for each incident.

Another benefit is the availability of true travel time information for planning and design functions. This information is historically collected one or two times per year by driving each section of roadway three or four times each peak period. The AVI system provides continuous travel time information for all peak periods, for every day of the year.

Cost constraints have limited implementation of previous methods of traffic management systems to small sections of the freeway system. This would delay implementation on some freeways as much as 10 to 15 years. The AVI system design enables a traffic management system to be implemented on the entire freeway/toll road/HOVL system in a short period of time (two to three years) at a relatively low cost (approximately \$20,000 per centerline kilometer).

FUTURE PLANS

As of August 1996, AVI Phases 1 and 2 are operational and Phases 3 and 4 are being installed and expected to be operational by January 1997. A Phase 5 is tentatively scheduled for implementation by 1998, and would expand the AVI system on the Sam Houston Tollway.

Phase 4 places additional reader stations on US 290 to reduce the spacing between stations. This section of freeway will be used to evaluate the ability to more quickly identify and better locate incidents. If this proves successful, stations may be added throughout the system.

Other applications of AVI are scheduled to be tested under the Priority Corridors Program. The main application is to use a “smarter” transponder that provides read/write capabilities and two-way communications from the roadside to the motorists. The first application will be with large trucks traveling through freeway to freeway interchanges that have reduced speed limits. The AVI system will be used to activate a warning device in the driver’s compartment if the truck’s speed is too high. Other applications will be investigated to provide general traffic conditions for persons that have the AVI transponders on their vehicle.

Finally, greater emphasis will be placed on the dissemination of the AVI information to the general public in forms that can be received anywhere and that can be easily understood.

REFERENCES

1. Smalley, Dennis G. and William R. McCasland. *A Public/Private Sector Partnership to Provide Traffic Information by Cellular Telephone Reports*. Research Report 1941-1, 1993.
2. Smalley, Dennis G., Dan R. Hickman, and William R. McCasland. *Design and Implementation of Automatic Vehicle Identification Technologies for Traffic Monitoring in Houston, Texas*. Research Report 1958-1, 1995.

