

C H A N N E L I Z A T I O N

by

Neilon J. Rowan  
and  
Thomas G. Williams

Research Report Number 19-4 (Final)

Channelization  
Research Project Number 2-8-60-19

Sponsored by

The Texas Highway Department  
In Cooperation with the  
U. S. Department of Commerce, Bureau of Public Roads

March, 1966

TEXAS TRANSPORTATION INSTITUTE  
Texas A&M University  
College Station, Texas

## ACKNOWLEDGMENT

The authors wish to express appreciation to all who helped make this research possible; to the Texas Highway Department and the U. S. Bureau of Public Roads for their joint support; to District 17 of the Texas Highway Department for making the installations that were studied; to the Project Advisory Committee for their advice and assistance; and to the many members of the TTI staff that contributed to this research.

## FOREWORD

In 1960, the research project, "Channelization," further designated as RP-24, was initiated by the Texas Transportation Institute for the Texas Highway Department. In 1962, the project was included in the cooperative research program with the Texas Highway Department in cooperation with the U. S. Department of Commerce, Bureau of Public Roads, receiving a new designation as Research Project 2-8-60-19. The general objective of the research was to investigate the effect of design, signing, and delineation of channelization on the factors of safety, efficiency of operation, and capacity. Four reports resulted from the research of the project. The first report published in 1962 was entitled, "Approach-end Treatment of Channelization--Signing and Delineation." The report was presented at the Forty-second Annual Meeting of the Highway Research Board, and subsequently published in Highway Research Bulletin 341. A second report was published in 1963 as TTI Bulletin 25, "Marking the Approach-ends of Channelization." The third report of the project was Research Report 19-3, "A Computer Technique for Perspective Plotting of Roadways." This fourth and final report presents all of the research results including summaries of the previously published information.

TABLE OF CONTENTS

	<u>Page</u>
INTRODUCTION .....	1
DELINEATION OF CHANNELIZATION .....	3
SIGNING THE APPROACH-ENDS OF CHANNELIZATION .....	10
MATERIALS AND METHODS OF MARKING THE APPROACH- ENDS OF CHANNELIZATION .....	15
A STUDY OF TRAFFIC ACCIDENTS IN CHANNELIZED AREAS .....	35
A STUDY OF THE VISUAL PERSPECTIVE OF CHANNELIZATION AND OTHER ROADWAY FEATURES .....	47
LIST OF REFERENCES .....	59

## INTRODUCTION

Channelization is a term used in reference to a broad spectrum of traffic control. By definition, "channelization of intersections at grade is the separation or regulation of conflicting traffic movements into definite paths of travel by the use of pavement markings, raised islands, or other suitable means to facilitate the safe and orderly movement of both vehicles and pedestrians."<sup>1</sup> Generally speaking, channelization implies some form of island or physical guidance system. As such, it constitutes an integral part of the geometric design of a new facility. In many cases, however, channelization is a remedial measure used to improve the operation of an obsolete facility. Regardless of the reason for its conception, the functional sufficiency of channelization is judged on the basis of how well the driver is able to see and comprehend the intent of the channelization. In other words, visibility is the most important characteristic of channelization.

In this research, primary consideration has been given to the approach-end treatment of channelization. Particular emphasis has been placed on methods of marking or delineating channelization so that it is visible to the driver under conditions of night driving in adverse weather. Studies were conducted to evaluate the relative visibility of signs used to direct traffic around the approach-ends of channelizing islands. Other studies were conducted to evaluate the relative visibility and serviceability of marking materials and devices for delineating islands. These studies included actual field observations as well as controlled tests.

In another closely related phase of the research, developmental work was performed on the materials and geometric configuration aspects of what might be termed "pre-treatment" of channelization---raised markings in advance of channelization to forewarn the driver. In addition to improved visibility, these raised markings provide a rumble effect to the encroaching driver.

In another phase of the research, an investigation of the safety aspects of channelization was made by a "before" and "after" comparison of traffic accidents occurring on a section of roadway that was channelized as a remedial measure. Seven miles of an arterial street were selected for the study.

In still another phase of the project, a computer program was developed to translate design data (station, elevation, and perpendicular offset data) into a perspective view of the roadway. The procedure utilizes a digital plotter in conjunction with a digital computer. With this program, the designer can select several viewing positions and distances to study his proposed design as the driver sees it, whereas he normally relies on plan and profile drawings.

Due to the nature of the various problems, it has been necessary to utilize qualitative as well as quantitative measures in this research. Certain phases of the research such as the visibility of signs and markings used in approach-end treatment are readily adaptable to a quantitative evaluation. On the other hand, much of the research could only be handled by qualitative engineering judgment.

## DELINEATION OF CHANNELIZATION

The primary function of a channelizing island is to control and direct a motorist into the proper channel for his intended route and thus assure safe and efficient traffic operation.<sup>1</sup> Since the installation of a channelizing island constitutes placing a physical object in the projected path of the traffic stream, adequate delineation of the island is of utmost importance. There are certain requirements that may be established regarding adequate delineation. By definition the term "delineation" must "portray" or "describe" the channelizing island. Therefore, adequate delineation should outline the island, giving the driver a complete picture of the proper vehicular path or paths to be followed. To give this "complete picture" the delineation devices or materials must have outstanding day and night visibility characteristics, even under adverse weather conditions.

An evaluation of the visibility and serviceability of various delineating devices and materials was one of the objectives of the research project on channelization. The research on delineation was conducted in two separate phases, (1) relative visibility and (2) serviceability under actual traffic conditions.

The devices and materials tested included the following:

1. Curb coating materials.
  - A. Traffic paint reflectorized with glass beads.
    - (1) On barrier curbs.
    - (2) On mountable corrugated curbs.
  - B. Special coating materials with reflective elements in suspension.
2. Prismatic (retro) reflectors.
3. Rectangular plate-type delineators (beaded reflector encapsulated in amber plastic).
4. Reflective sheeting.
5. Low intensity curb lights.

## Visibility Studies

The results of visibility studies using the curb coating materials and the prismatic reflectors were reported in an earlier publication.<sup>2</sup> Additional studies were conducted at a later date to provide a complete series of tests on the materials and devices listed above.

A detailed description of the test procedure is given in the earlier report. In summary, however, the studies were conducted under controlled conditions at the Texas A&M Research Annex. A channelizing island was simulated using each of the delineation materials and devices. The curb coating materials were applied to curb sections constructed of wood to represent barrier curbs, and to special corrugated curb sections cast with concrete. The corrugated curb sections are illustrated in Figure 1. In actual practice the corrugated curbs are normally constructed as mountable curbs three to five inches in height. They have been used on medians of freeways and major arterials with reasonable success. The curbs produce an audible rumble or hum plus a vibratory sensation when a vehicle encroaches, but little was previously known of their visibility characteristics when painted and reflectorized.

The visibility tests were conducted by requiring four selected observers to drive a vehicle at uniform speed through the test section and indicate the point from which they could see the number of units displayed. An opposing vehicle was located adjacent to the nose of the simulated island as if it were in the inside opposing lane. Both the opposing vehicle and the observer's vehicle displayed low-beam headlights.

A summary of the results of the visibility tests is graphically illustrated in Figure 2. In general, the curb coating materials were not effective in delineating the channelizing island. The barrier curbs with beads-on-paint markings showed a slight advantage over the corrugated curbs and the barrier curbs coated with the special reflective coating. However, none of them were considered to be effective. All of the coating materials have reasonably good reflective characteristics when they are placed perpendicular to the vehicle headlights and the driver's line of sight. However, when they are placed essentially parallel to the light beam their visibility is reduced substantially.

The four other materials or devices tested showed visibility distances three to five times greater than those of the coating materials. The prismatic reflectors used in the tests were the same as those used in guard posts and in high-quality signs. Their greater efficiency results from the fact that they have plane reflective surfaces whereas beads have spherical reflective surfaces. The reflective sheeting is manufactured under controlled conditions and as a result provides a better quality surface. The encapsulated amber



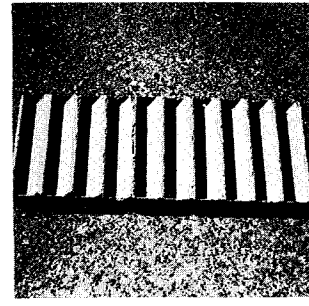

**CORRUGATED CURBS**

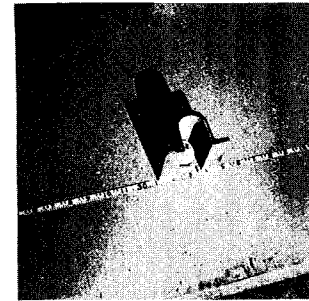
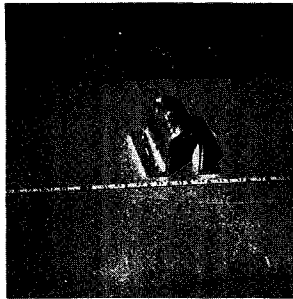

**"TUNNEL" REFLECTORS**

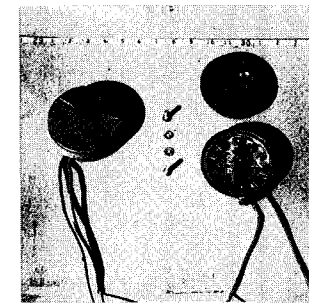

**BARRIER CURBS**

**LOW-INTENSITY LIGHTS**

**FIGURE 1-ILLUSTRATIONS OF DELINEATION DEVICES**

reflectors are subject to the same quality control and manufacture as the reflective sheeting. Of course, all of the reflective devices have a tremendous advantage over the curb coating materials because they are placed perpendicular to the headlight beam.

The low-intensity curb lights are highly efficient because they are not dependent upon the return of a headlight beam for their efficiency. The lights used in these studies are lights which would normally be inset in the pavement surface. They are illustrated in Figure 1. They were bi-directional lights with 10-watt, 12-volt lamps.

### Serviceability

The results of the visibility tests of delineation materials and devices showed definitely that the prismatic reflectors, the reflective sheeting, the encapsulated reflectors and the curb lights offered the greatest effectiveness under controlled conditions of testing. To evaluate the efficiency of the various materials of devices under actual traffic conditions, they were installed on divisional islands in the Bryan-College Station area. In these installations the units were spaced 12 to 20 feet apart along the island curb. In earlier temporary installations of the prismatic reflectors the 5/8 inch reflector buttons were attached to the front of a wood block and the block was glued to the top of the curb. In later tests, however, the reflector housing shown in Figure 1 was made of cast aluminum and 1 1/2 inch prismatic reflector buttons were attached inside the housing with an epoxy adhesive. The purpose of this housing was to protect the reflector from splash, but the housing had a tendency to collect sand and other foreign matter from the roadway surface. An attempt was made to correct this problem by providing a vent-hole under the reflector so that wind pressures created by the passing automobile would blow the sand and foreign matter on through the housing below the reflector. The vent-hole improved the performance, but it did have a tendency to become clogged with leaves and other objects.

The idea of placing the reflector at the back of a "tunnel" is reasonably satisfactory. The housing could be redesigned to provide a larger vent-hole which would keep the reflector clean. Even then, however, the reflector would require periodic maintenance, which would be of a specialty nature possibly involving a portable air compressor and some means of washing the face of the reflector inside the housing. On the other hand, flush-mounted reflectors would simplify the maintenance procedures considerably.

To facilitate observations by the research staff, the Texas Highway Department installed white three-inch-diameter prismatic reflectors along several divisional islands in the Bryan-College Station area. These reflectors were flush-mounted approximately 16 inches above the pavement immediately behind the curb. A periodic maintenance program was established whereby

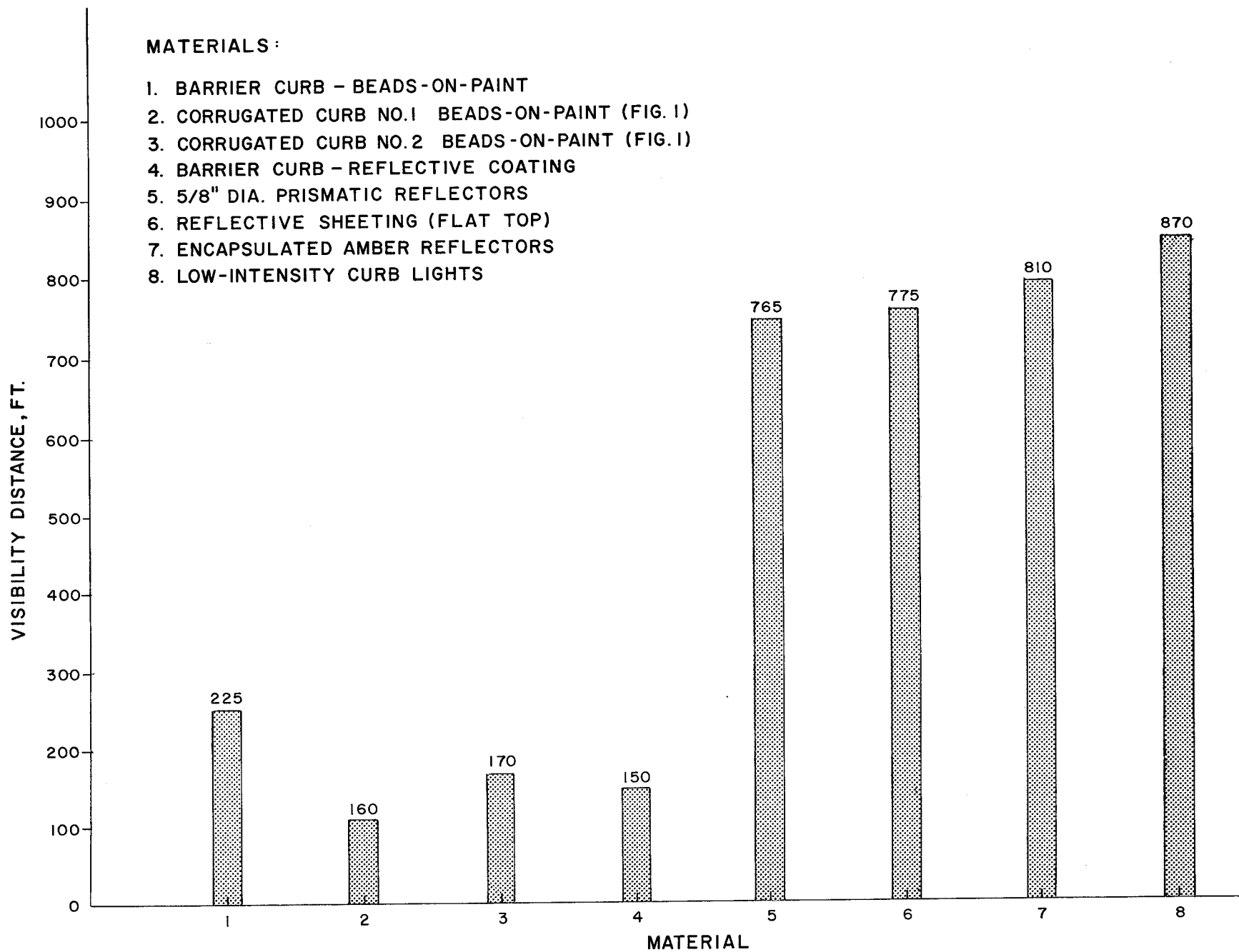

FIGURE 2-COMPARISON OF RELATIVE VISIBILITY DISTANCES OF DELINEATION DEVICES AND MATERIALS

these reflectors were wiped clean once each month. Under practically all weather conditions this maintenance program was sufficient to provide good delineation of the islands. In many cases, however, there was a tendency for these delineators to be damaged because they were mounted very close to the roadway.

The encapsulated amber reflectors were installed on two divisional islands in the Bryan-College Station area. These delineators were three inches by five inches, and were mounted with the long side vertical and the bottom of the delineator two inches above the island surface. The outside edge of the delineator was six inches behind the curb. One of these locations was near several unpaved driveways, and therefore the splash problem was critical. At this location the encapsulated delineators collected a heavy coating of roadfilm which necessitated cleaning about every 30 days during the winter months when inclement weather was prevalent. At other times, however, practically no maintenance was required. At the second location, roadfilm was rather slow to collect on the face of the delineators and as a result, the delineators required cleaning only about once every six months to one year.

Prismatic delineators subjected to the same conditions, lost their reflective efficiency due to the roadfilm much more rapidly than did the encapsulated delineators. The reason for this is not readily apparent, but it is believed that the difference was due to the fact that the reflective element in the prismatic reflector was molded directly to the plastic which formed the outside surface of the delineator, whereas the plastic surface on the encapsulated delineator was separate from the reflective element. In other words, the encapsulated delineator consisted of a beaded sheet enclosed but not fused to the plastic covering. For some reason this system appears to retain its reflective efficiency much longer than the prismatic reflector system.

Special delineators were built using amber reflective sheeting. Fifteen square inches of the sheeting were applied to the face of a short section of rectangular steel tubing and the section of tubing was attached to the surface of a divisional island. Although the color and initial reflectivity were excellent, the sheeting was highly susceptible to roadfilm. The units were less satisfactory than the prismatic reflector units.

Observation of both amber and white delineators showed that the amber units were much more effective for us on channelizing islands. The amber delineators did not blend with the opposing headlights as did the white reflectors and curb lights. Also, amber appropriately implies a danger area when the island is not traversable. It is also significant to point out the advantage

of low mounting heights used in all of the test installations. The delineators are more closely and readily associated with the island area and do not get lost in a maze of opposing headlights. There is the disadvantage that they are more susceptible to splash and roadfilm in the low mounting positions.

The low-intensity curb lights were placed on a divisional island at a 20-foot spacing and six inches behind the curb. These lights were merely strapped down to the island surface. The lights were not connected to a continuous power source but were operated occasionally by battery power. The main reason for installing the lights under actual traffic conditions was to get some idea of the problems encountered in the accumulation of dirt on the face of the lenses of the lights. The installation was kept under observation for a period of approximately one year and there was practically no tendency for dirt to accumulate on the face of the lenses.

From observation of these various materials and devices subjected to normal traffic and weather conditions, it appears that any one of the devices will do a satisfactory job when it is used in conjunction with an organized maintenance program. These observations show that probably the encapsulated delineator would require the least amount of maintenance. However, the prismatic reflector, when clean, has considerably greater efficiency than is actually needed and therefore can afford to have its efficiency reduced substantially by a coating of roadfilm.

In view of the fact that a satisfactory job of delineation can be obtained through either of the reflective devices, the curb lights are not considered justified because of their high initial cost and the problems of continuous power consumption and maintenance.

## SIGNING THE APPROACH-ENDS OF CHANNELIZATION

In this phase of the research, studies were conducted to make a comparative evaluation of the performance characteristics of several types of "KEEP RIGHT" signs used to mark the approach-ends of channelizing islands. The signs selected for study are described in Table A. Basically, they are similar in geometric configuration but differ in the types of materials used and the methods of illumination.

The results of similar studies were reported in an earlier report, "Approach-end Treatment of Channelization - Signing and Delineation," but there was some nonuniformity in two of the signs. After publication of the report, it was possible to correct the conditions of nonuniformity, and the studies were repeated.

The sign tests were conducted at the Texas A&M Research Annex. The test site, which was formerly an Air Force Base, provided excellent control of such variables as grade, alignment, external light sources, and opposing headlights. It was recognized that these idealized conditions would not yield actual visibility and legibility distances that would apply directly to field conditions. However, the selected test procedure and conditions were expected to yield a relative comparison of the visibility and legibility characteristics of the signs.

In the selection of criteria for evaluating the comparative performance of the signs, consideration was given to the functional nature of the sign. Its application is frequent and consistent and the sign becomes a symbol more than a literal message. For this reason, the shape and general configuration of the legend probably conveys the message before the driver can read the legend. Therefore, the visibility distance, ie. the distance at which the driver recognizes the sign was selected as the primary criterion, and legibility was selected as a secondary criterion.

To facilitate the study, four observers were selected to drive a vehicle at uniform speed (15 mph) through the test area and indicate the point at which they could recognize the general form of the sign. The distance at which the observer could read the message was also recorded. Prior to beginning the study, trial runs of the tests were conducted to familiarize the observers with the different signs and sign arrangements. It was assumed that this procedure would reduce the variability resulting from increased familiarity with the signs and thus provide more consistent and reliable readings. Anticipation by the observer was reduced by making random selection of both observers and signs during the tests.

TABLE A  
DESCRIPTION OF SIGNS USED IN VISIBILITY  
AND LEGIBILITY TESTS

Sign Number	Type of Sign by Material and Method of Illumination	Size of Sign	Size of Letters
1	Beads-on-Paint. Black letters on white background (Texas Highway Department Standard).	24" x 30"	5"
2	Reflective Sheeting. Black letters on white background.	24" x 30"	5"
3	White letters and arrow inset with prismatic reflectors on black background.	24" x 30"	5"
4	Internally illuminated. Black letters on white opaque background.	24" x 30"	5"
5	Same as Number 1 except black and white hashmark panel mounting below sign.	24" x 30" Panel 24" x 36"	5"
6	Same as Number 1 except externally illuminated.	24" x 30"	5"
7	Same as Number 2 except externally illuminated.	24" x 30"	5"
8	White reflective sheeting letters and arrow on black background.	24" x 30"	5"

To simulate the most critical visibility condition that would normally be expected at actual installations of the "KEEP RIGHT" sign, a vehicle was placed as if in the opposing lane of traffic and immediately adjacent to the sign. As reported in the earlier study this was found to be the most critical position of the opposing vehicle. Both the opposing vehicle and the test vehicle displayed low-beam headlights during the tests.

#### Method of Analysis

The data collected in the study were analyzed by two statistical tests. An analysis of variance test was used to evaluate any significant differences in the various signs tested. A multiple range test was applied to the average visibility and legibility distances to rank the signs according to their order of superiority.

#### Visibility Comparison

A comparison of the visibility and legibility distances of the various signs is shown in Figure 3. This comparison shows the average visibility and legibility distances for each of the signs and the results of the multiple range test in arranging the various signs in groups of significant differences.

According to the comparison, there was no significant difference in the visibility distances of the prismatic reflector sign (Number 3) and the sign composed of reflective sheeting on black background (Number 8). These two signs had the best visibility characteristics of all the signs tested.

The second group consisted of four signs. There were no significant differences among the internally illuminated sign (Number 4), reflective sheeting sign (Number 2), and the externally illuminated signs (Numbers 6 and 7). The third and lowest group in order of performance consisted of the standard beads-on-paint type (Number 1) and the same sign with a reflectorized hash mark panel mounted below (Number 5).

#### Legibility Comparison

A comparison of the average legibility distances is also shown in Figure 3. The results of the range test on legibility distances differed slightly from the results of the test on visibility distances. The signs were grouped into two groups instead of three.



MULTIPLE RANGE TEST (99% CONFIDENCE LEVEL)

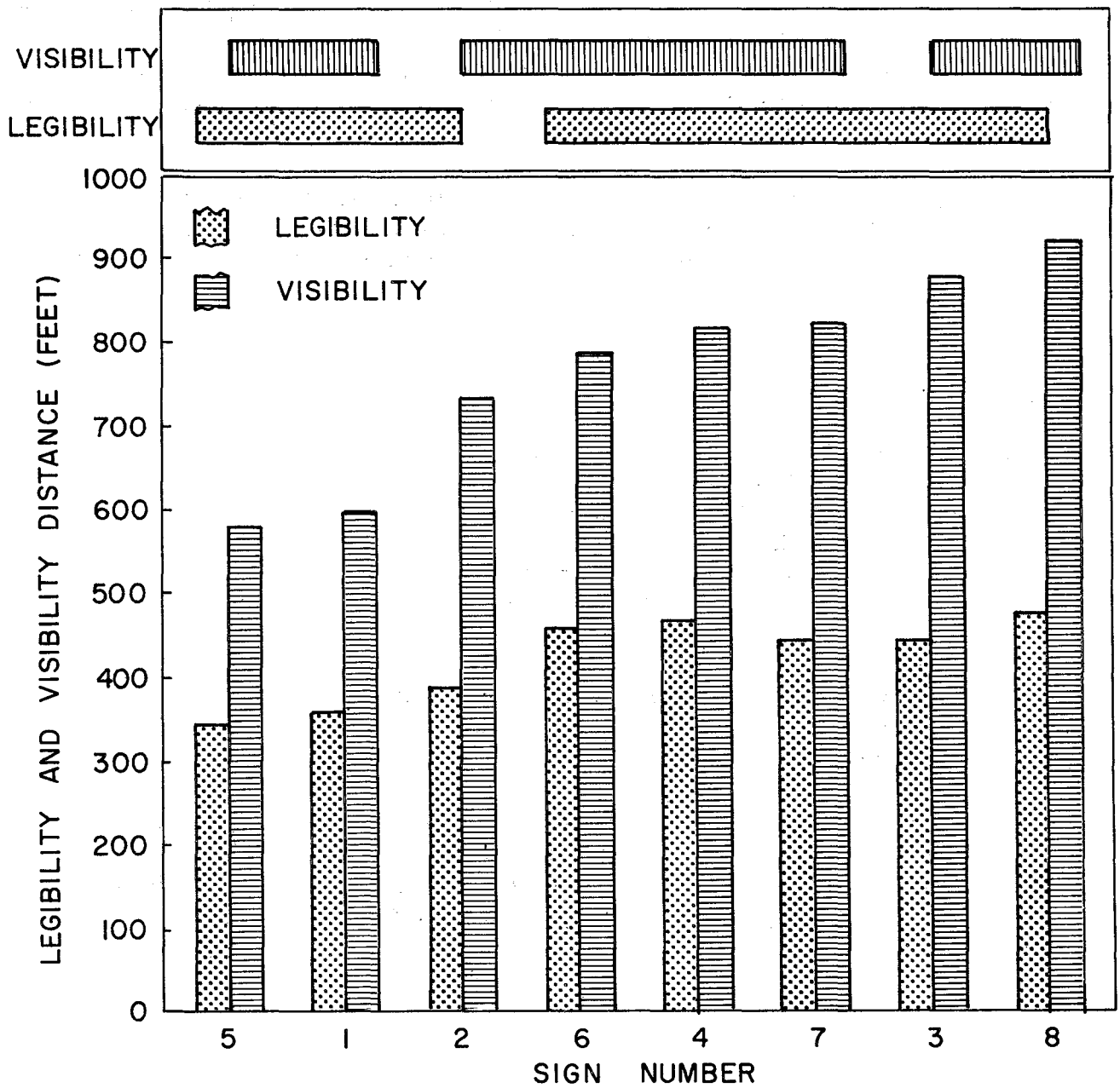

LEGIBILITY AND VISIBILITY DISTANCE OF SIGNS TESTED

FIGURE 3

The first group included the white reflective sheeting on black background and the prismatic reflector signs, both of which were in the first group of the visibility comparison. Also, the internally illuminated sign (Number 4) and the two externally illuminated signs (Numbers 6 and 7) were included in the first group of the legibility comparison. The multiple range test indicated that there was no significant difference in the legibility distances of these signs, and this is clearly evident in Figure 3.

The second group in

The second group in the legibility comparison included the standard beads-on-paint type (Number 1) and the same sign with the hash mark panel mounted below (Number 5). In addition, this group included the reflective sheeting sign (Number 2).

### Evaluation of Results

According to the results of this study there was no significant difference in the visibility and legibility distances of the prismatic reflector sign (Number 3) and the reflective sheeting on black background (Number 8). It should be noted that the prismatic reflector sign has been used successfully in signing on high type facilities; whereas the sign with reflective sheeting letters was developed for this research and has not seen general application in the field.

The internally illuminated sign was ranked fourth in visibility; however, it was second in the legibility tests. The brilliance of the sign seemed to wash out the arrow and letters at greater distances, thus reducing the visibility distance.

The externally illuminated signs showed no difference in their visibility or legibility characteristics. The standard beads-on-paint type (Number 1) and the same sign with the hash mark panel mounted below were in the bottom group. The hash mark panel apparently made no difference in visibility.

MATERIALS AND METHODS OF MARKING  
THE APPROACH-ENDS OF CHANNELIZATION

A few years ago one of the Texas Highway Department Districts introduced a new technique for marking the approach-ends of channelizing islands and freeway ramps. Instead of merely painting the configuration on the pavement surface, a system of raised stripes for the approach-end treatment was constructed by the "surface treatment" or inverted penetration construction method. That is, hot asphalt was sprayed on the pavement surface and a coverstone was immediately applied to form the lines. This configuration was then painted and beaded in the normal procedure.

It was anticipated that this technique for striping the approach-ends would improve the visibility of the markings, especially during inclement weather because the reflective surfaces would project above water that normally inundates paint lines and renders them ineffective. Secondly, the raised stripe would produce a rumble effect to warn the driver of encroachment on the approach-end treatment.

Since little was known of the performance characteristics of this new raised stripe in comparison with conventional paint lines, a study of the visibility characteristics of the two materials was initiated as a part of this research project. The results of this study published in Texas Transportation Institute Bulletin No. 25 entitled "Marking the Approach-Ends of Channelization" showed that the visibility distance of a painted and reflectorized raised stripe was not reduced by wetting the stripe and the related pavement, whereas, the visibility of a conventional reflectorized paint line was reduced approximately 60 per cent.

Although the raised stripes constructed for test purposes in connection with the research showed a decided advantage in the visibility test, there was a general consensus of opinion that they did not produce adequate rumble, particularly for application in low-speed areas. This was due partly to the configuration and partly to the limitations of the height of stripe that can be satisfactorily attained using the surface treatment method of construction. In order to produce a higher stripe, it would be necessary to use a larger coverstone. The retention of this coverstone in actual service is dependent upon the amount of imbedment in the asphalt that can be attained in construction and this depth of imbedment is limited by the amount of asphalt that may be spread satisfactorily. Therefore, when larger coverstones are used, there is a tendency to "shell out" which results in appreciable loss of coverstone and consequently a loss in the stripe.

The shortcomings in producing an adequate "rumble" effect served as a primary basis for the second phase of the research. Based on an appraisal of the previous studies and experience, the objectives of this second phase were to determine the materials and methods of constructing raised stripes for approach-end treatment of channelization and ramp terminals. The criteria for which these materials and methods would be judged were established as follows:

1. The materials and methods in approach-end treatments should permit the construction of stripes of sufficient height to provide a significant rumble effect.

2. The finished stripe should have an irregular surface similar to that obtained by the surface treatment method of construction to provide adequate drainage for improved visibility.

3. The completed stripe should provide good durability, retaining most of its original contrast for a reasonable time.

4. The installation of the raised stripe must be simple and inexpensive.

The first step in this study was to assimilate information on conventional materials which appeared to be adaptable to the particular type of construction involved in the raised stripe. Those taken under consideration are listed as follows:

1. Pigmented paving materials.

2. Portland cement concrete.

3. Epoxys and resins.

4. Bituminous paving mixtures.

5. Prefabricated composite materials.

Many of these materials were eliminated in a preliminary evaluation and those which appeared promising were subjected to experimentation under both laboratory and field conditions. Their evaluation and the various experimental procedures will be discussed in the order listed above.

#### Pigmented Paving Materials

The pigmented paving materials which are relatively new to the paving industry were given immediate consideration because the pigmentation would

conceivably provide a natural and lasting contrast, regardless of the amount of wear on the stripe. The problem would then be reduced to one of producing an irregular surface and reflectorization. Early in the consideration of these materials it was found that in their current stage of development, the materials are inherently "tacky" and thus have a tendency to discolor quite rapidly by collecting dirt and foreign matter from the roadway surface. In limited experimental work, glass beads were applied to the surface of a new stripe formed using the pigmented paving materials, and the coarse texture provided by the application of beads seemed to increase the tendency to collect dirt and to discolor. On the basis of these preliminary investigations, the pigmented paving materials were ruled out as having no immediate application; however, they definitely warrant reconsideration when the "tackiness" problem has been corrected.

### Portland Cement Concrete

A study of the literature and field practices indicated the normal procedure in using Portland cement concrete for jiggle bars and other channelization devices involved either the placing of a pre-cast device in the pavement or forming this device during construction. It was felt that there is insufficient information available on forming these devices in new construction. Where these devices might be applied to an existing situation, the cost to excavate the existing pavement and place the precast device would rule out its feasibility.

### Epoxy and Resins

Review of current literature indicated that Kermit and Hein had recently studied the effect of rumble stripes on traffic control and driver behavior.<sup>4</sup> The rumble stripes used in their research consisted of a series of spaced overlays placed on the roadway surface using 3/4 inch stones and surface treatment techniques. Synthetic resin formulations were used in place of asphalt cement to hold the stones in place.

The materials and methods used in constructing the rumble stripes were discussed in an earlier report by Schmidt, Percival and Hein.<sup>5</sup> In reviewing this earlier report, it was noted that the polyester resins must be applied at a high temperature and under precise control of conditions of application. Also, the equipment required for the installation was considerably more expensive than is normally found in the maintenance equipment inventories of the various state highway departments. The particular equipment used in this research was apparently designed for the application of the surface treatment in large areas, extending the full width of a traffic lane. It would not be immediately adaptable to the construction of stripes for the approach-end treatment of channelization.

Rather than pursue the technique of hot application of polyester materials, an investigation was made of the availability of cold application materials which would be more adaptable to maintenance operations. A cold application material, Shell #MRAX-1028 in two parts, A and B, was obtained and used in laboratory experimentation to bond crushed limestone rock. The material was then used to construct one-by-seven-foot stripes in the approach-end treatment to a divided highway.

In preparation for the installation, the asphaltic concrete pavement surface was broomed clean and the stripes were laid out. The two parts of the resin were combined and thoroughly mixed in accordance with instructions for application. The resin was then applied in a one-by-seven-foot flat form at the rate of approximately 0.2 gallons per square yard. A THD Grade 3 crushed limestone was then spread on the resin immediately after the forms were removed. A pneumatic type hand roller was used on the stripes immediately.

The resin reached its initial set 17 minutes after combining the two parts. Allowing five minutes mixing time, only 12 minutes remained to spread the resin and place the aggregate. The stripes had completely set in approximately two hours and traffic was allowed on the surface.

The stripes were broomed the following day and it was observed that much of the stripe had broken loose from the asphaltic concrete surface. It was apparent that proper bond had not been attained between the new resin and the fairly old asphaltic concrete surface. If the surface had been etched with an acid solution prior to application, better bond would have been attained; however, the experimental application was aimed at evaluating the material's performance under conditions of application easily adaptable to normal maintenance operations.

The stripes were inspected on frequent occasions for a period of approximately 18 months after installation. After the initial loss of approximately 30 per cent of the stripe, there was no evidence of appreciable wear or loss of stripe. Apparently the resin is a good bonding agent when applied to a well-prepared surface. However, the short working time and the special surface preparation requirements do not lend themselves to routine maintenance operations.

### Slurry Seal Mixture

The major difficulty in constructing a bituminous surface treatment of substantial height to provide the desired rumble effect lies in retaining large coverstone. As discussed earlier, this lack of retention is due to the natural limitations on the depth of embedment of the large stones in the asphalt binder; therefore, the objective of this specific phase of the research was to develop a binder

which would provide sufficient embedment to retain large aggregates and thus provide sufficient height of the raised stripe.

A review of current seal coating practices indicated that the slurry seal mixture was worthy of consideration in this particular application because the mixture normally has a high viscosity which will facilitate greater embedment of the coarse aggregate. Also, the fact that the mixture is handled and placed cold made it particularly adaptable to the construction of raised stripes, a job which would normally be handled by the maintenance personnel on a small job basis.

The slurry seal mixture used in constructing the raised stripes consisted of a Bauxite slag aggregate passing a No. 10 sieve, field sand and an asphalt emulsion, Bitucote SS-1H, having a residual penetration of 70. To this bonding mixture was added a coarse aggregate to provide height and surface roughness in the stripe.

Material specialists were consulted on the proportioning of materials, and trial batches were made in the laboratory to determine proportioning that would yield the most desirable height and surface texture of the stripe. Also, a test installation was made on test strips at the Texas A&M Research Annex. For this test installation two alternate mix designs were selected representing the extremes in the range of coarse aggregates used in the laboratory experimentation. Both were used for a side-by-side comparison. Half of the installation was constructed using a THD Grade 1 crushed stone having a maximum size of one inch, while the other half was constructed using a THD Grade 4 crushed stone having maximum size of 5/8 inch. Specifications for these two aggregates are given in Table B.

Repeated traffic applications on the test installation showed that the portion containing the large aggregate (THD Grade 1) lacked sufficient durability. There was a tendency for the large stone to "shell out" under traffic. On the other hand, the portion of the installation containing the small aggregate (THD Grade 4) showed good durability, but the surface of the stripe was too smooth for good visibility under wet weather conditions. As a result of these observations, a second test installation was designed to utilize a stone of intermediate size.

For the second installation, a test section was selected on a state highway where observations could be made of the materials performing under actual traffic conditions. The test section was located about four miles west of Bryan, Texas, on S. H. 21 where the highway changes from a two-lane roadway to a four-lane divided section. The transition occurred near the crest of a hill which limited the view of approaching drivers. The terminal of the median was marked with a

TABLE B  
 TEXAS HIGHWAY DEPARTMENT  
 SPECIFICATIONS FOR  
 AGGREGATE FOR SURFACE TREATMENTS\*

	Percent by Weight			
	Grade 1	Grade 2	Grade 3	Grade 4
Retained on 1" Sieve	0			
Retained on 7/8" Sieve	0-2	0		
Retained on 3/4" Sieve		0-2	0	
Retained on 5/8" Sieve	15-45		0-2	0
Retained on 1/2" Sieve		20-35	5-20	0-2
Retained on 3/8" Sieve	85-100			5-25
Retained on No. 4 Sieve	95-100	85-100	85-100	85-100
Retained on No. 10 Sieve	98-100	98-100	98-100	98-100

\*Adopted by the State Highway Department of Texas, January 2, 1962.



"KEEP RIGHT" sign visible to approaching traffic for a distance of approximately 300 feet. The experimental approach-end treatment was approximately 450 feet in length, and extended over the crest of the hill, thus providing traffic a guide through the transition. A plan view of the approach-end treatment is shown in Figure 4.

The approach-end treatment was formed of raised segments approximately 5/8 inch in height, one foot wide and seven feet in length. The materials used in the raised stripe consisted of a slurry seal mixture including one-half-inch crushed limestone aggregate of uniform gradation. The materials were combined in a small concrete mixer in the following batch weight proportions:

70 lbs. of slag aggregate	20 lbs. of 2.4 gal. of emulsion (Bitucote SS1H)
30 lbs. of field sand	100 lbs. of 1/2" crushed limestone

The entire installation was made by maintenance forces from Texas Highway Department District 17. General supervision was provided by Project personnel.

The approach-end treatment was laid out completely with a string line prior to installation and a paint pilot line was placed on the pavement to outline the configuration. Then the cross bars shown in Figure 4 were located on the pavement and the seven-by-one-foot segments of the sidelines were located with respect to the cross bars. After the layout was completed, the areas to receive the raised stripe were primed with RC-2 liquid asphalt. This prime coat would be equally or more important if the existing surface was portland cement concrete; however, it would not be essential on new bituminous surfaces.

Construction of the raised stripes was essentially a manual operation; however, it appears to be a procedure adaptable to mechanization. The materials were combined in the mixer and transferred to the place of installation by wheelbarrows. The mixture was then placed in one-by-seven-foot wooden forms having a height of one-half inch (see Figure 5). The mixture was leveled in the forms and particular care was necessary to avoid segregation of the materials. This segregation would result in some of the stripes having an excessive amount of slurry which would cover the coarse aggregate and provide a smooth surface rather than the rougher surface required for good visibility. After the material was leveled and the proper surface texture obtained, the form was lifted from the stripe and it was permitted to set. The finished stripes were not compacted.

The stripes in the approach-end treatment were placed one day and painted the next. This installation took place in the fall when the weather was cool and slightly damp. Consequently, the stripes were not completely cured when the painting took place. The paint sealed the surface and thus retarded the action

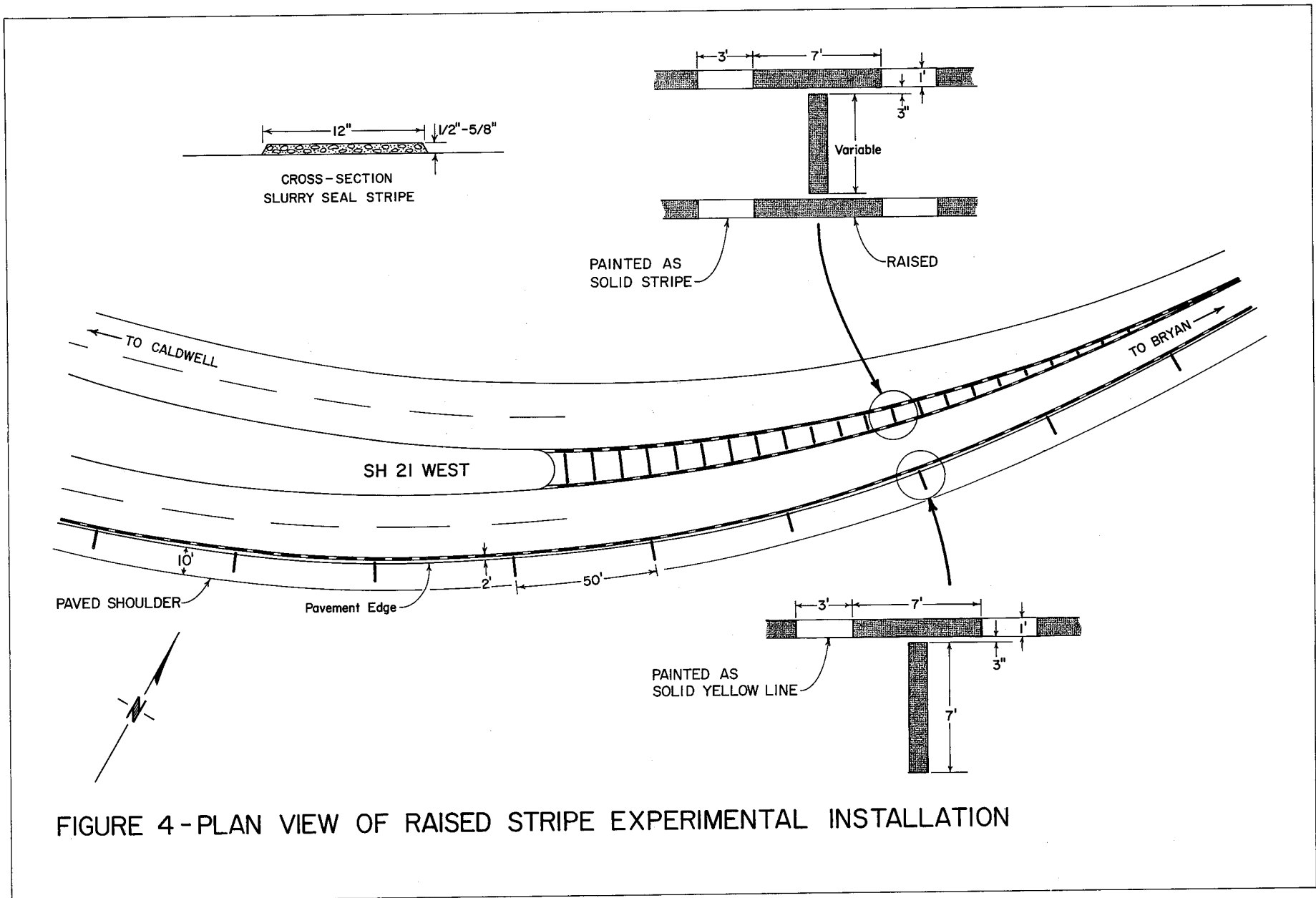
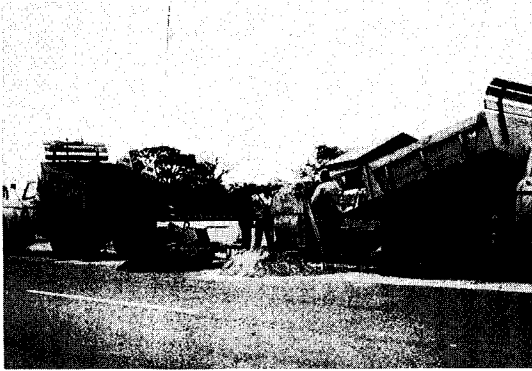
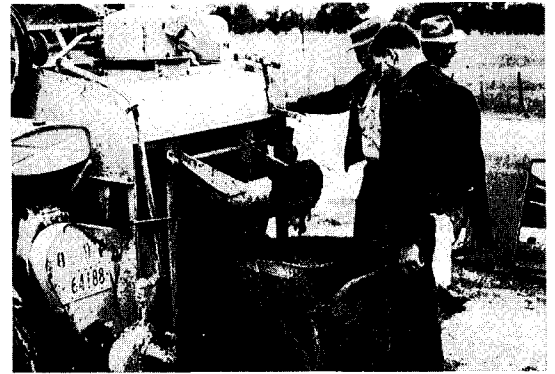

FIGURE 4 - PLAN VIEW OF RAISED STRIPE EXPERIMENTAL INSTALLATION



(1)



(2)



(3)



(4)

**FIGURE 5 - ILLUSTRATIONS OF MIXING AND PLACING  
RAISED STRIPES OF SLURRY SEAL MIXTURE**

of the emulsion and some of the stripes remained soft. The stripes eventually cured, but it is believed that additional time should have been allowed for curing between the time of installation and the painting operation.

A raised stripe configuration as shown in Figure 4 was constructed along the right-hand edge of the roadway where the facility narrowed from the four-lane divided section to a two-lane roadway. This stripe was warranted because the transition took place on the crest of a hill and around a horizontal curve. The edge of the pavement did not offer sufficient natural delineation for this complex transition and therefore the edge stripe was considered essential, especially at night.

The edge stripe was constructed in the same manner as the approach-end treatment but prevailing weather conditions delayed painting of the stripe for several days. Immediately after completion of this stripe, it began to rain and light rain continued for several days. Traffic cones were placed along the stripe for 24 hours and then removed. The slurry mixture required several days for complete setting and it appeared that traffic would completely destroy the stripe. Although traffic on the stripe caused the loss of some aggregate, it actually improved the surface texture of the stripe. After five days the stripe was painted and reflectorized, and it has actually held up better than the stripe used in the approach-end treatment.

The geometric configuration of the approach-end treatment does not conform to any recommended standard practice and this deviation is justified on the basis of two important considerations. First, it will be noted that the cross bars in the configuration are perpendicular to the direction of traffic flow. They were placed in this manner mainly for ease of construction. Before this particular configuration was selected for the study, the true function of the diagonal stripe was considered in relation to its intended purpose---to indicate the direction that the driver should take around the island or median. The driver views the approach-end treatment at a very small vertical angle and has difficulty in detecting the diagonal position of the stripes. Furthermore, questioning of several drivers indicated that they did not realize the intent of the designer in the application of the diagonal stripes.

The second variation from standard practices was in the dashed configuration of the edge lines of the approach-end treatment. This edge line was painted solid, 12 inches in width but the raised stripes were segmented in a repeating cycle with seven-foot segments of raised stripe separated by a three-foot space. This particular configuration was selected to conform generally to the average wheelbase of the automobile, 120 inches or 10 feet. It was presumed that the most effective rumble would be produced when the front and rear wheels were experiencing a vertical transformation simultaneously. This condition is illustrated later in Figure 8.

Summary Evaluation - The installation was kept under close observation for 18 months including the extreme ranges of seasonal weather conditions. The installation was not repainted during the period of observation. It did, however, receive two coats of paint immediately after construction because considerable strike-through of the asphalt was noted in the first coat. The surface has retained reasonably good color contrast and reflectivity.

The stripe has exhibited outstanding durability characteristics. The only cracks that have developed have resulted from reflection cracking up through the existing pavement from the original concrete paving under the bituminous surface.

It is significant to point out that for several months of the observation period, an asphaltic concrete plant has been located immediately adjacent to the approach-end treatment. Ingress and egress to the plant have been across the approach-end treatment. Even this significant amount of heavy truck traffic has not produced appreciable damage to the stripe (Figure 6). There is evidence, however, that the paint lines are beginning to wear. The trucks frequently spill small amounts of the bituminous mixture on the approach-end treatment and these materials probably contribute substantially to the wear of the paint surface due to a grinding action.

Several highway engineers were asked to evaluate the approach-end treatment from the standpoint of its effectiveness in producing a rumble to warn encroaching drivers. The general consensus was that the raised stripe produces an excessive amount of rumble for normal high-speed highway conditions. On the other hand, this particular stripe would be well suited to installations in lower speed areas. It should be pointed out that the stripe has an average height of approximately 5/8 inch, although 1/2 inch crushed stone was used in the construction. These observations of the raised stripe indicated the need for conducting additional studies of a lower profile of raised stripe for high-speed conditions. These additional studies pertained to various geometric configurations of approach-end treatment again utilizing the surface treatment method of construction.

#### Surface Treatment Methods

Based on the observations of the slurry seal raised stripe which indicated the need for a less pronounced but equally effective rumble, additional studies were made using the surface treatment method of producing a raised stripe. Three test installations were made, one for observation under actual traffic conditions and two were made on the paved test strips at the A&M Research Annex. All of these test installations utilized a 90 penetration asphalt cement as a binder for THD Grade 3 crushed stone. The gradation of this coverstone is given in Table B.

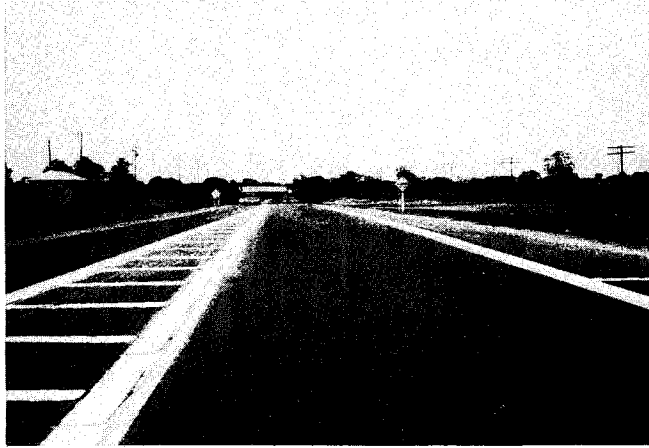

**TWO WEEKS AFTER COMPLETION**



**EIGHTEEN MONTHS AFTER COMPLETION**

**FIGURE 6 - ILLUSTRATION OF PERFORMANCE OF SLURRY SEAL RAISED STRIPES**

The primary objective in constructing these additional test installations was to determine the most effective means of producing a significant rumble effect without the danger of causing the unsuspecting driver to lose control of his vehicle. In selecting the design for these three test installations, particular attention was given to the pattern and sequence of vertical translations of the front and rear wheels of a vehicle caused by the edges of the raised stripes. The translation patterns are illustrated in Figure 8.

The first installation (Figure 7A) was composed of cross bars five feet wide, spaced three feet apart. A contrasting paint line was superimposed but did not completely cover the cross bars. The vertical translation of the front and rear wheels on this particular design (Figure 8A) was rather erratic, and not particularly effective.

The second design where the cross bars were three feet wide, and spaced at three-foot intervals (Figure 7B) produced a very effective rumble. Repeated observations by several highway engineers indicated that the intensity of the rumble increased as the vehicle traveled along the test section. This characteristic which is considered desirable from the standpoint of warning the driver was produced by the cyclic effect of the vertical translation of the front and rear wheels (Figure 8B).

The third design (Figure 7C) did not produce any appreciable rumble effect because the vehicle could recover from the vertical translations produced by one stripe before it engaged a subsequent stripe (Figure 8C).



The designs illustrated in Figures 7A and 7B are not only desirable from the standpoint of effective rumble but are also advantageous from the standpoint of ease of construction. These designs required considerably less time and effort in layout than previous installations discussed herein.

Another advantage of these two designs results from the same effect being produced on a vehicle regardless of whether it has encroached only slightly into the approach-end treatment or whether it has encroached a great amount. In other configurations such as shown in Figure 7C, the intensity of the rumble is reduced as the vehicle crosses the edge stripe and passes on into the central portion of the approach-end treatment where there is increased risk to the vehicle.

### Prefabricated Striping Materials

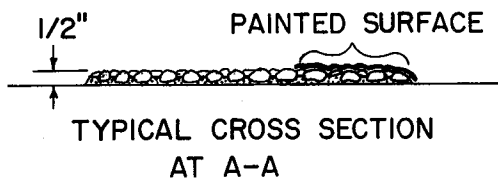
In an earlier phase of the research when the test section for the visibility studies on raised stripes was being constructed, an idea was conceived and consideration was given to the possibility of prefabricating raised stripes.



LEGEND:  
 SURFACE TREATMENT  
 REFLECTORIZED PAINT STRIPE

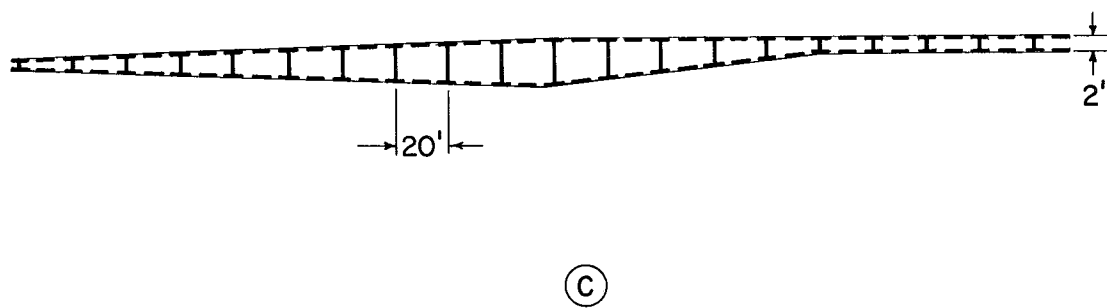
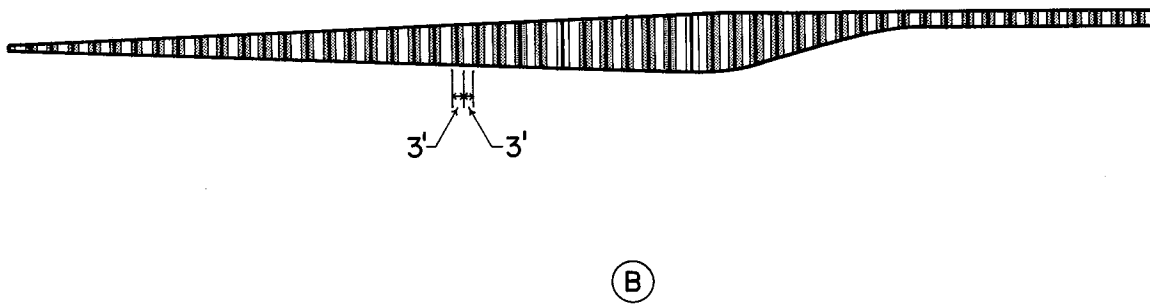
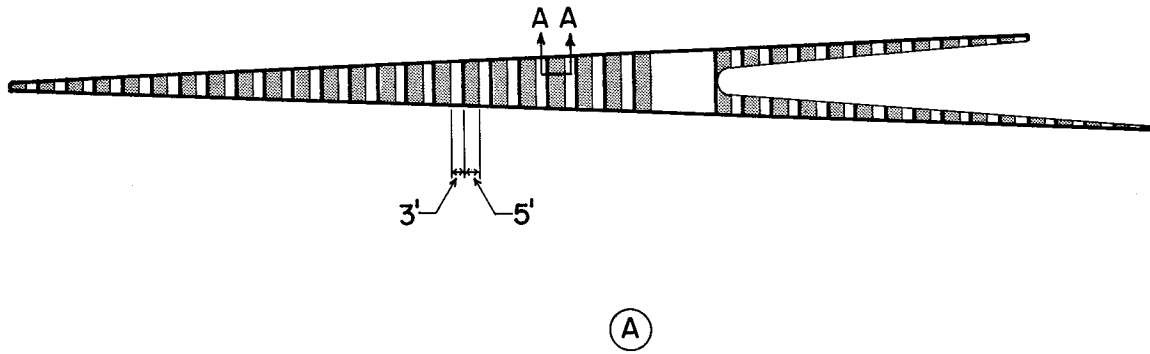
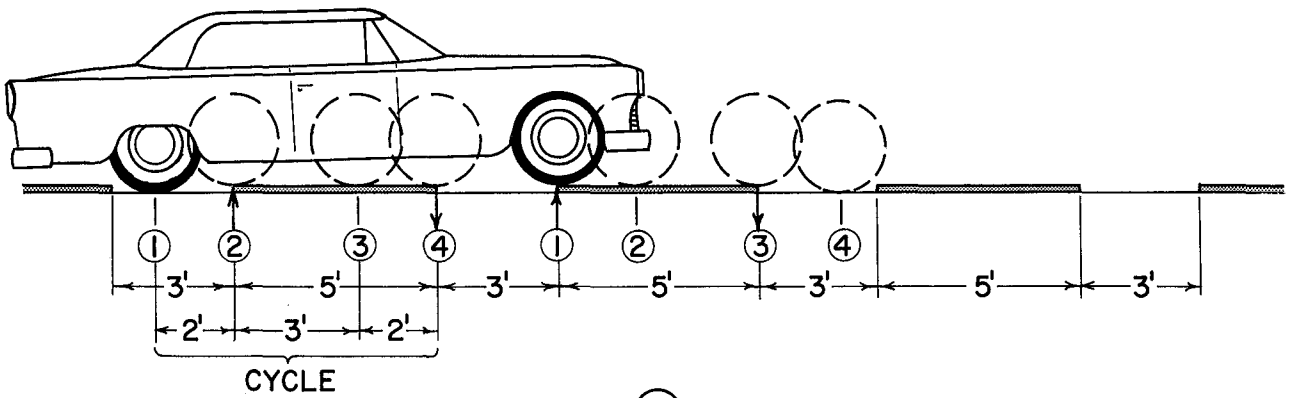
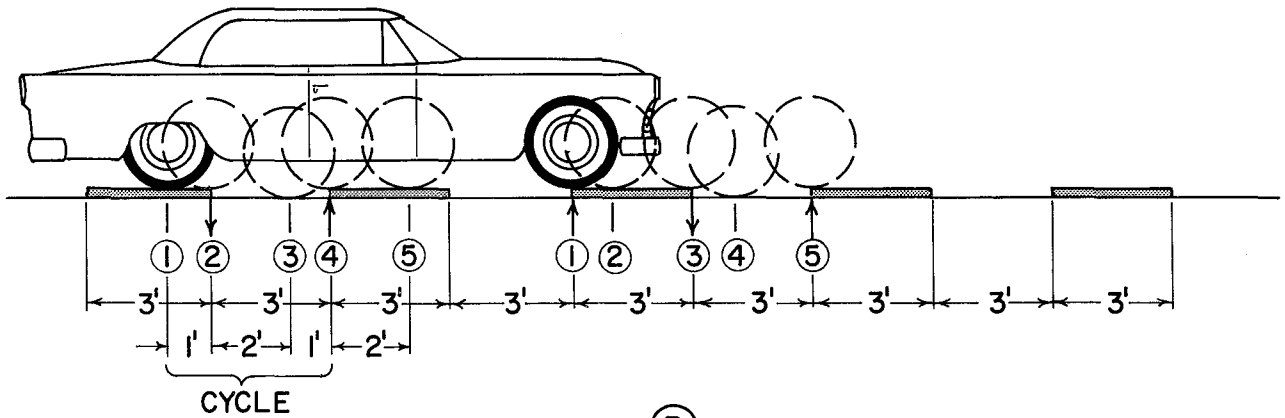

FIGURE 7 - EXPERIMENTAL INSTALLATIONS OF  
 SURFACE TREATMENT TYPE  
 RAISED STRIPES





(A)



(B)

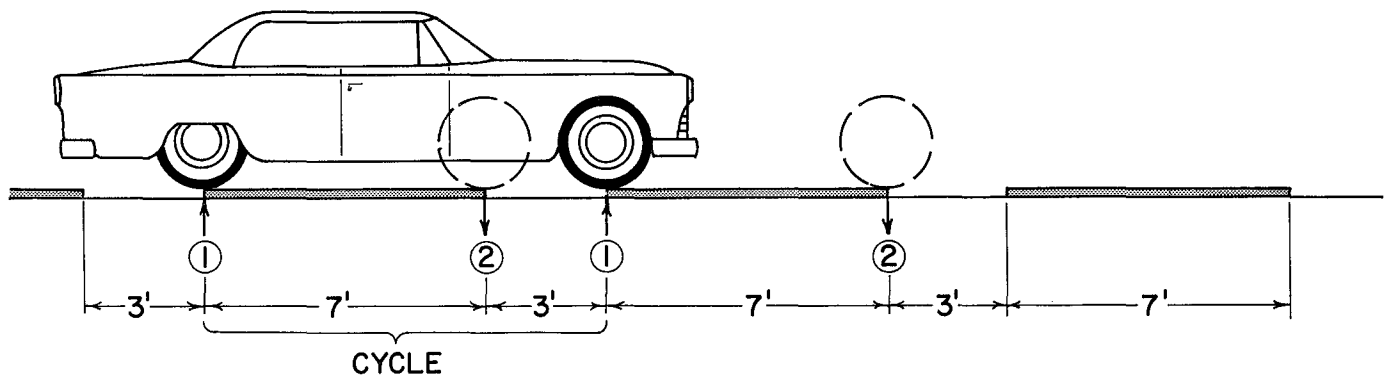

(C)

FIGURE 8-ILLUSTRATION OF RUMBLE EFFECT PRODUCED BY RAISED STRIPES

Some laboratory experimentation was performed using a heavy kraft paper, asphalt cement and expanded shale-type lightweight aggregates. The objective of this experimentation was to duplicate as nearly as possible the surface treatment method of construction in producing long strips of the striping material. These strips would then be cut and shaped to complete the desired configuration of the approach-end treatment. It was soon realized that an extensive outlay of equipment and assembly line experience would be most advantageous in advanced experimentation with the idea.

Several roofing companies were contacted regarding the possibility of constructing the raised stripe in much the same manner as roofing material is manufactured. As a result, a representative of the Johns-Manville Company, Dr. Fred L. Pundsack, visited with project and Texas Highway Department personnel to discuss the needs and the general requirements of the desired marking material.

The Johns-Manville Company experimented with the suggested technique, that is, applying asphalt and aggregate to a felt or paper mat but soon decided to pursue another alternative, to form a stripe using high-pressure molding of a filled asphalt material. This material could be molded into any desirable shape or pattern, but the initial stripes were molded six inches wide and four feet long. The molded stripes had a knobby surface (see photograph Figure 9) which would extend above the water during a normal rainstorm, and they were painted and reflectorized to provide day and night contrast.

A test installation was made on the west approach to S. H. 21 and West 25th Street in Bryan during August, 1964. Additional test installations were arranged for locations in Lufkin and San Antonio.

The test installation in Bryan is shown in Figure 9. It should be noted that this approach-end treatment extended beyond a side street and thus would be subject to a considerable amount of turning traffic which would give any material a severe durability test.

One thing very strongly in favor of the raised stripe was the simplicity of installation. The normal installation procedure involved laying out the approach-end treatment configuration with a pilot line which would likely be used in any case. The exact position of each section of stripe was then marked with chalk. The markers or stripe segments were placed on the pavement upside down so that the sun would soften the air-blown asphalt filler that was placed on the back of the stripe during the manufacturing process. The crossbars in the configuration were made up of the stripes cut to fit using an ordinary roofing knife or pocket knife.

A cold application mastic material furnished by the manufacturer was then brushed on the bottom surface of the stripe with a paint brush. The stripe was immediately inverted and placed into position. The stripes bonded to the surface

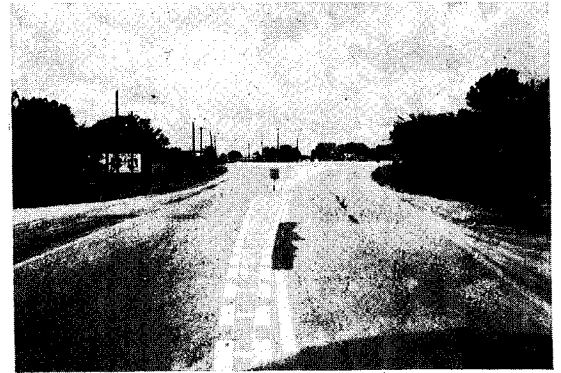

**BEFORE AND AFTER INSTALLATION**



**APPLYING MASTIC  
TO STRIPE**

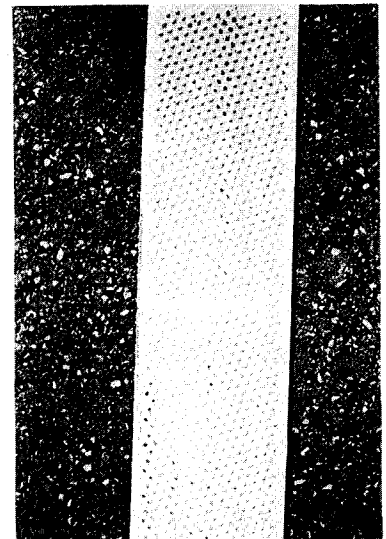

**CLOSE - UP OF STRIPE**

**FIGURE 9 - ILLUSTRATIONS OF PREFABRICATED  
RAISED STRIPE INSTALLATION**

generally within one hour dependent upon preheating of the stripe by the sun. In some cases, however, full bond was not attained for two to three days. This is believed to be due to an insufficient amount of the mastic material. A better installation or better bond could have been obtained had a greater amount of the mastic been used in application of the stripe.

Periodic observations of the experimental installation were made for approximately 18 months. During the first few months it was noted that the surfaces of the stripes were discolored due to weather and dirt. Also, traffic turning across the approach-end treatment had worn the paint from the knobby surfaces which contributed considerably to the discoloration. However, fairly good reflectivity was retained for approximately six months. In the latter part of the observation period, the appearance of the stripes grew progressively worse, and after approximately one year several of the stripes had been lost or broken. In general, the installation was not successful.

Although this particular installation has not proven satisfactory, the research staff felt that there was merit in the prefabricated raised stripe concept. However, a considerable amount of additional research to develop a durable and lasting reflective surface will be required to produce a marketable product. It is possible that pigmentation and reflective elements should be combined in the molding material to provide the same color and reflectivity regardless of the extent of wear.

## Summary of Results

This research has shown that effective markings for the approach-end of channelizing islands, medians and ramps can be constructed with selected materials to provide good surface texture for visibility and substantial height for a rumble effect to warn the driver. Also, the method of application, principally the configuration of the raised stripe, can be controlled to enhance the rumble effect for more positive warning to the driver.

From the standpoint of being able to control the height of stripe, a slurry mixture was most satisfactory in constructing the raised markings. The slurry mixture consisted of an asphalt emulsion, water, field sand, slag aggregate, and a crushed limestone aggregate. The slurry served to provide adequate imbedment for the crushed stone to give good durability. The particular gradation of the crushed stone selected provided the desired height of stripe while the angularity of the stone provided satisfactory surface texture for visibility purposes.

The surface treatment method of constructing raised markings provided excellent surface texture for visibility purposes, but it was difficult to construct a stripe of sufficient height to provide adequate rumble. When the size of the stone was increased to provide the desired height, retention of the stone became a serious problem. It was possible, however, to vary the configuration of the stripes and cross bars in the approach-end treatment to increase the rumble effect produced with relatively small aggregate.

The research showed that other materials such as pigmented paving materials, Portland cement concrete, and certain polyester resins were not satisfactory materials for constructing raised markings. At the present stage the pigmented paving materials discolor rapidly due to an inherent tackiness of the material. Portland cement concrete markings could be utilized but they are considered prohibitive from an economic standpoint except when installed in new construction. The research did not cover this particular aspect of the material. The polyester resins have been used satisfactorily in previous research on rumble stripes, but the outlay of equipment and the precise nature of the application of these materials are considered prohibitive from the standpoint of general maintenance operations.

A preliminary study of the feasibility of prefabricating raised stripes indicated that the idea was feasible when considered from the standpoint of ease of installation. However, the materials developed for the first test installation proved to be unsatisfactory. For the installation, strips of material were formed by injection molding of asphalt and filler materials. These strips were then painted and beaded for reflectorization. Wear and discoloration soon rendered the strips ineffective. If a satisfactory material can be developed, then this method of marking approach-ends appears feasible.

## Recommendations

It is recommended that the results of these studies be utilized in conjunction with the results from previous research in this area to formulate design standards for marking the approach-ends of channelizing islands, medians, and freeway ramps. Also, these materials and methods can be used to provide more effective edge markings where they are specifically needed to channelize traffic in transition zones where the number of lanes is reduced.

## A STUDY OF TRAFFIC ACCIDENTS IN CHANNELIZED AREAS

One phase of this research was devoted to determining the effect of intersection channelization on safety of traffic operation. A study was conducted to analyze comparatively the statistics of traffic accidents occurring before and after channelization was installed on an arterial type street. To facilitate this research, a section of heavily traveled arterial street was selected in which channelization has been installed recently at several of the intersections. At the time the research was conducted, the roadway best fitting this requirement was a section of U. S. Highway 290 in Northwest Houston. Traffic volumes on the facility were substantial, and a significant number of left-turn movements were being made from the roadway onto several arterials intersecting the highway. Prior to 1959, the seven-mile section selected for study was a two-lane facility with paved shoulders. However, because of the high traffic volumes on the facility, it was being used as a four-lane roadway, especially at the signalized intersections. In 1959, part of the facility was widened and divisional island channelization was installed at several of the major intersections to provide separate left-turn lanes. Also at that time most of the study section was marked for four-lane operation.

Reconstruction of the facility and installation of the channelization was begun in November, 1958, and completed in September, 1959. One-year study periods were selected immediately before and after this construction period. Accident records for the study area were obtained for the "before" period from November 1, 1957, to October 31, 1958. A comparable period for the "after" study was November 1, 1959, to October 31, 1960.

As shown in the schematic diagram in Figure 10, the entire study area was divided into 17 subsections based on conditions of the roadway, channelization and signalization. The 17 subsections were then categorized into three sections described as follows:

Section A - A one and three-fourths mile section which provided two-lane operation in both the before and after study periods.

Section B - The unchannelized subsections marked for four-lane operation during the after period.

Section C - The channelized subsections which provided the four-lane operation with added left-turn lanes during the after study period.

Accident data for the two study periods were obtained from the city of Houston, where the official records were microfilmed. Additional information was obtained from the Maintenance Division of Texas Highway Department District 12. The maintenance records provided information on accidents involving signs on the islands which in most instances were not reported to the Houston Police Department.

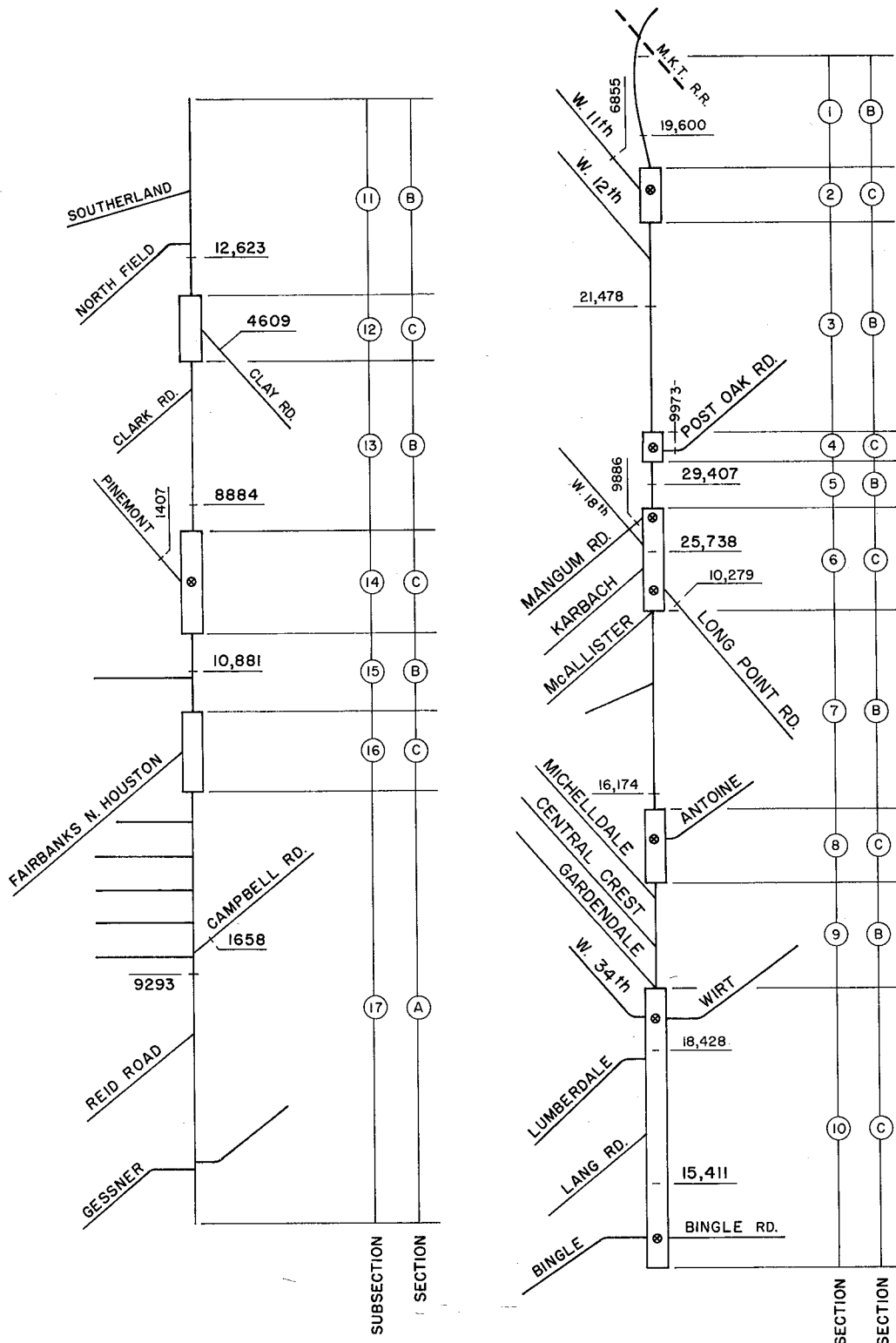

SCHEMATIC DIAGRAM OF ACCIDENT STUDY SECTION

FIGURE 10



In the analysis, all accidents for each of the before and after study periods were grouped according to the section (A, B, or C) in which they occurred. Grouping into these sections provided:

- (1) A comparison for no change in channelization to serve as an index of comparison (Section A),
- (2) A comparison where the roadway had been widened to four lanes but remained unchannelized (Section B), and
- (3) A comparison where the roadway had been widened to four lanes and divisional island type channelization installed.

The criteria selected for a comparative analysis of the accident data are as follows:

- (1) Total number of accidents,
- (2) Accidents per one hundred million vehicle-miles,
- (3) Accidents by type,
- (4) Accident severity---property damage and personal injury, and
- (5) Accidents by light conditions.

Statistical tests, specifically Chi-square tests, were performed in the analysis of the data. In general, these tests indicated statistical significant differences which were not meaningful from a practical standpoint. For this reason the results are presented in graphic form to facilitate conclusions to be drawn by the reader based on experience and engineering judgment.

#### Total Accidents

A comparison of the total number of accidents occurring during each of the study periods is shown in Figure 11. In Section A, which was under two-lane operation during both of the study periods, there was a sizeable increase in the total number of accidents, whereas both the four-lane sections (B and C) showed no appreciable change. In Section C, 22 of the 114 accidents occurring during the after period were incidents reported by the maintenance personnel where vehicles had struck signs on the channelizing islands.

#### Accident Rates

For the purpose of comparing accident rates for the before and after conditions, the types of accidents which would logically be related to channelization were considered independently. These accidents are generally classified

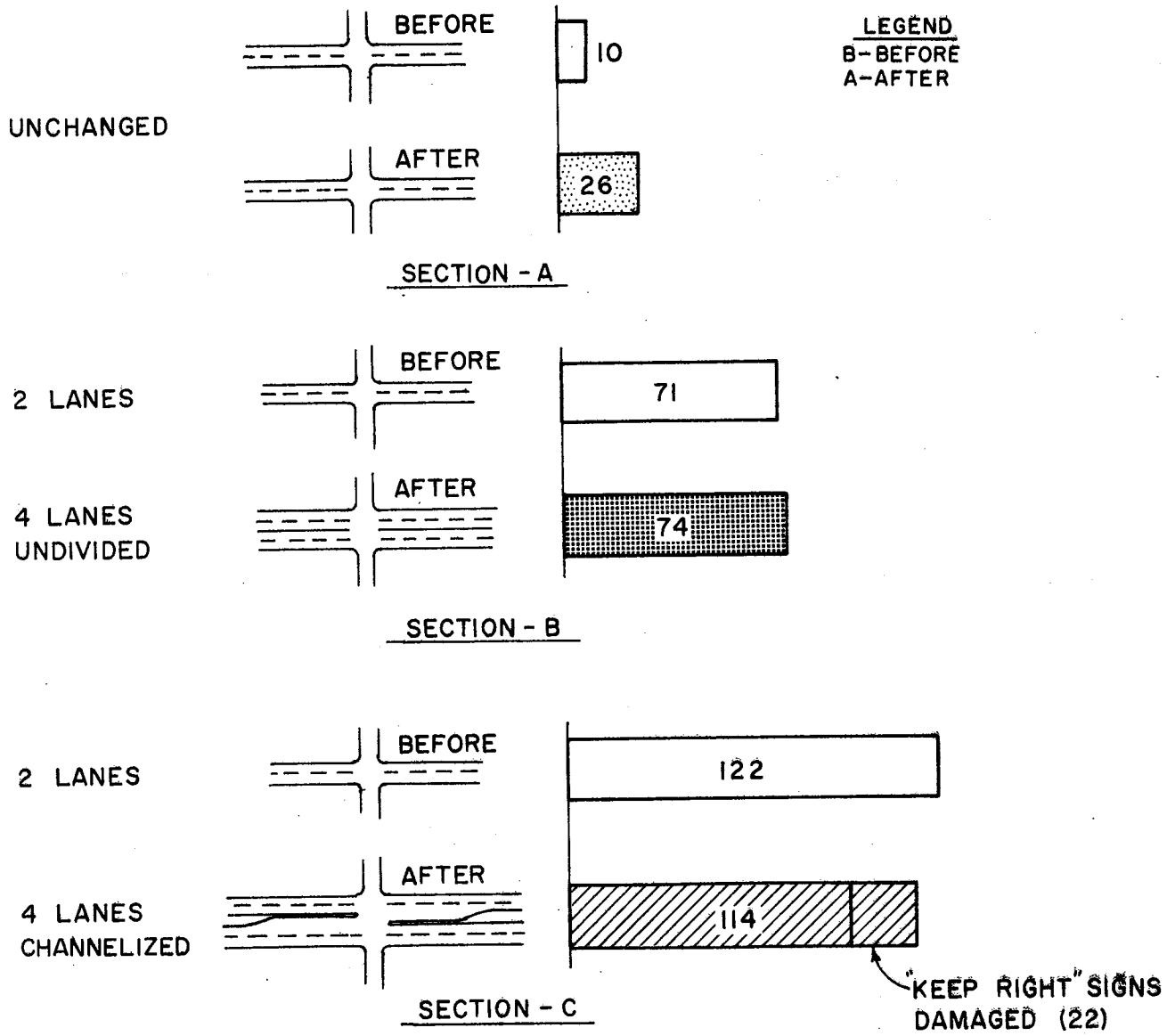

COMPARISON OF TOTAL ACCIDENTS

FIGURE II

as "nonintersection" and "rear-end." A comparison of each of these two general types is shown in Figure 12. In Section A, where there was no change in the roadway, there was a significant increase in both types of accidents. In Section B, where the roadway had been widened to four lanes, there was no appreciable change in the number of accidents. However, in Section C, where channelization was introduced, there was a significant decrease in both types of accidents.

The "nonintersection" and "rear-end" types of accidents were further classified according to day/night conditions. This comparison is shown in Figure 13. For all practical purposes, the trends were essentially the same as in the previous comparison of before and after conditions. However, the nighttime accident rate was considerably greater than the daytime rate.

#### Type of Accidents

Accident data for each of the study periods were classified according to type and compared as shown in Figure 14. This comparison shows that rear end accidents accounted for more than half of all reported accidents. Normal increases of rear end type were observed in Sections A and B, while a significant decrease was noted in Section C, the channelized section.

The frequencies of other types of accidents were generally too low to permit a reliable comparison, except possibly in Section C. In Section C, however, there was a general decrease, except in fixed object collisions, and collisions involving vehicles turning left from the arterial and vehicles on the cross street. Practically all of the increase in fixed object collisions was attributed to collisions with signs located on the channelizing islands.

#### Accident Severity

Personal Injury-A comparison of accidents on the basis of personal injury is shown in Figure 15. Considering the total number of accidents in which personal injuries were involved, Section A shows a tremendous increase (2 to 15), while Section B did not show any difference. However, Section C showed a 25 per cent reduction in personal injuries. When personal injuries were expressed in terms of personal injuries per accident, Section A, the two-lane section, showed a very significant increase for the after study period, while there was little or no change in personal injuries per accident in Sections B and C. Since Section A was control section, this comparison possibly indicates improved safety for Sections B and C due to the changes in conditions.

Property Damage-Property damage was expressed on a per accident basis for a comparison between the two periods. This comparison, shown in Figure 16, did not show any difference in property damage for the two study periods.

LEGEND  
 B-BEFORE  
 A-AFTER

NON - INTERSECTION

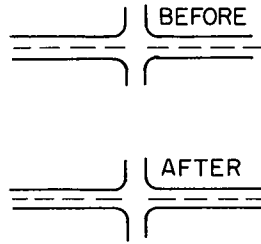
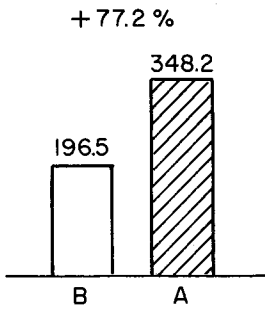

SECTION - A

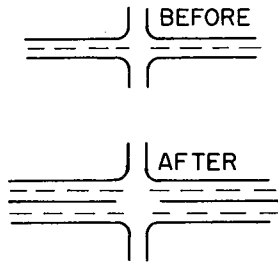
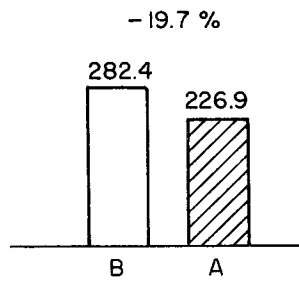

SECTION - B

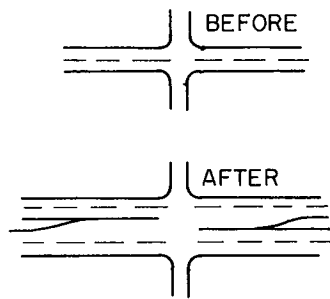
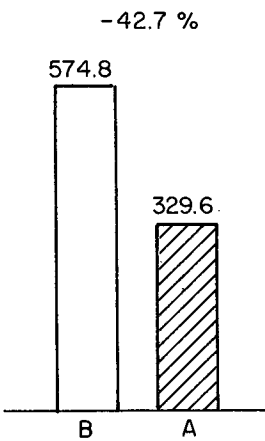

SECTION - C

REAR ENDS

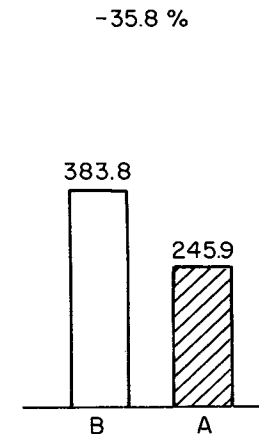
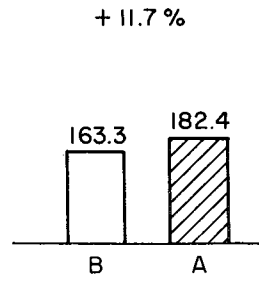
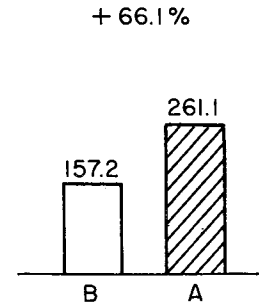

COMPARISON OF ACCIDENT RATES  
 ACCIDENTS PER 100 MILLION VEHICLE MILES

FIGURE 12

**NON-INTERSECTION**

**LEGEND**  
B-BEFORE  
A-AFTER

**REAR ENDS**

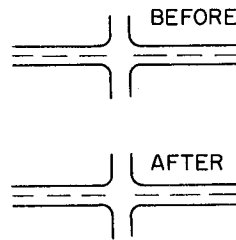
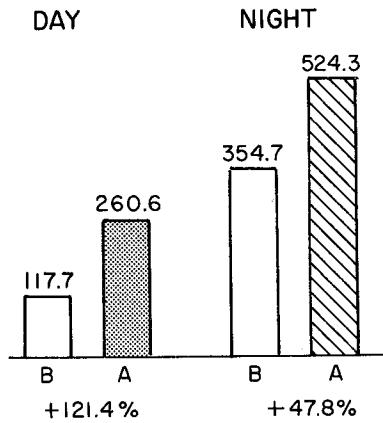

**SECTION - A**

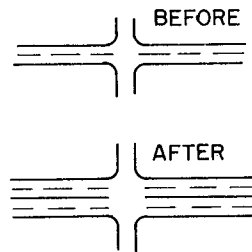
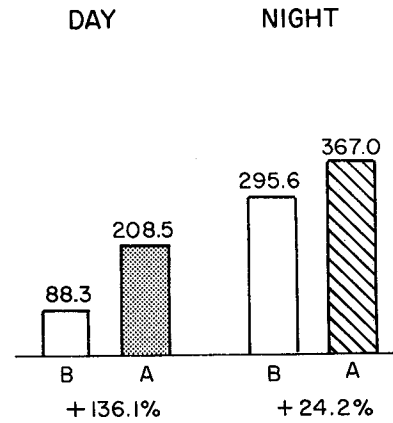

**SECTION - B**

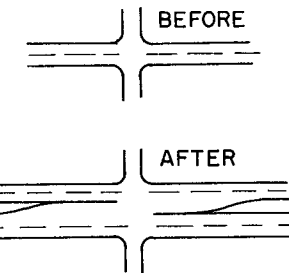
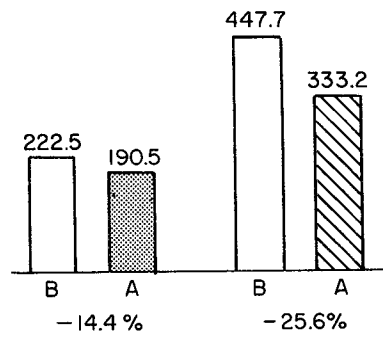

**SECTION - C**

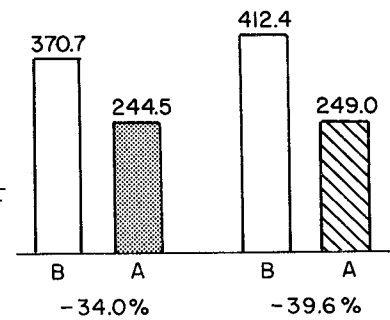
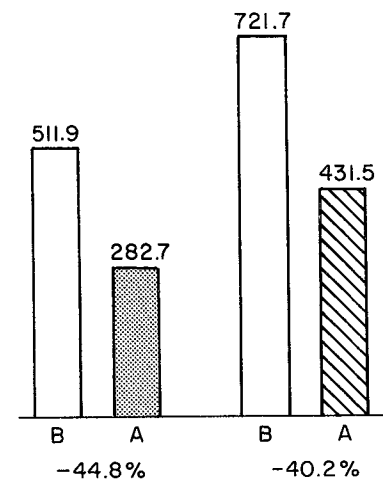
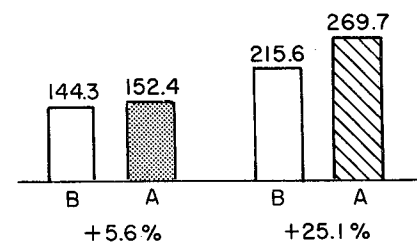

**COMPARISON OF ACCIDENT RATES FOR DAY AND NIGHT**  
ACCIDENTS PER 100 MILLION VEHICLE MILES

FIGURE 13

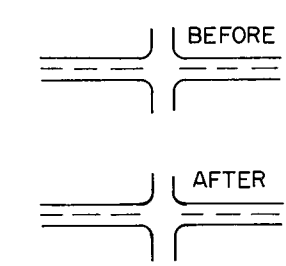

LEGEND  
 B — BEFORE  
 A — AFTER

SECTION - A

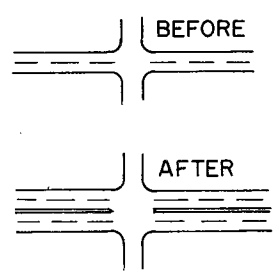
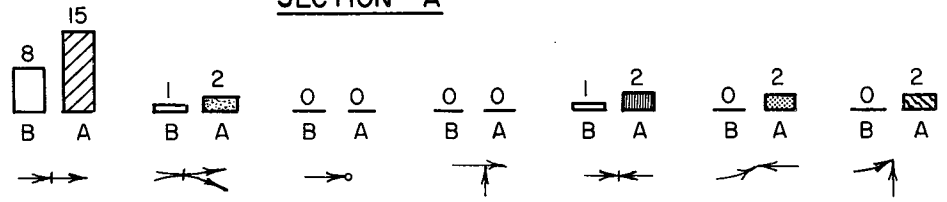

SECTION - B

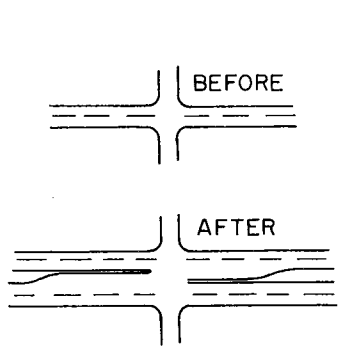
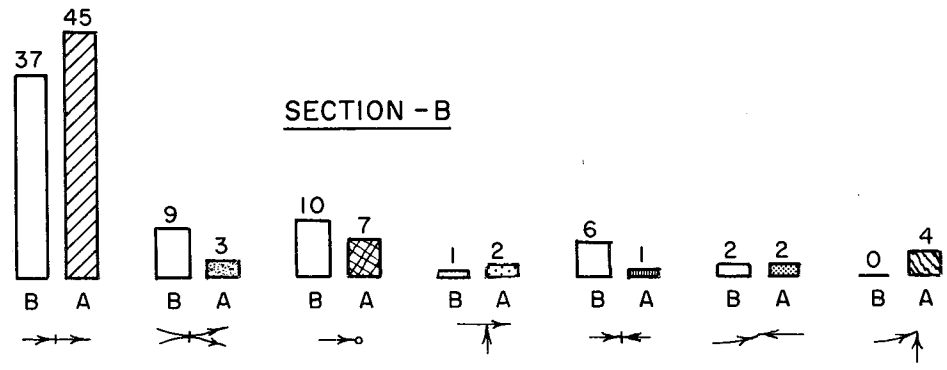

SECTION - C

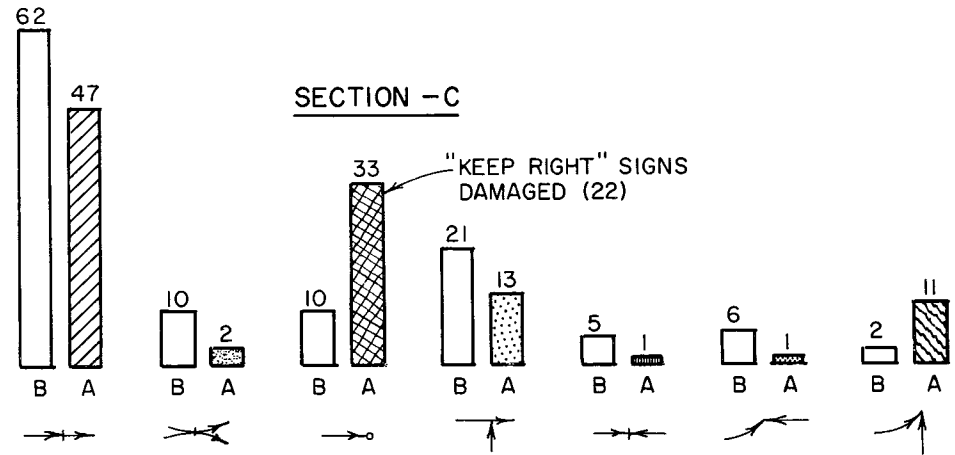

COMPARISON OF ACCIDENTS BY TYPE

FIGURE 14

PERSONAL INJURY

PERSONAL INJURY / ACCIDENT

LEGEND  
B-BEFORE  
A-AFTER

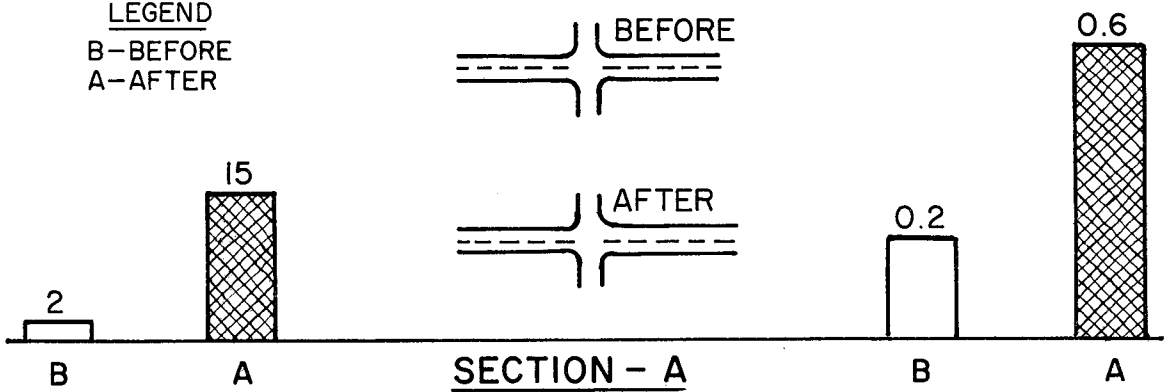

SECTION - A

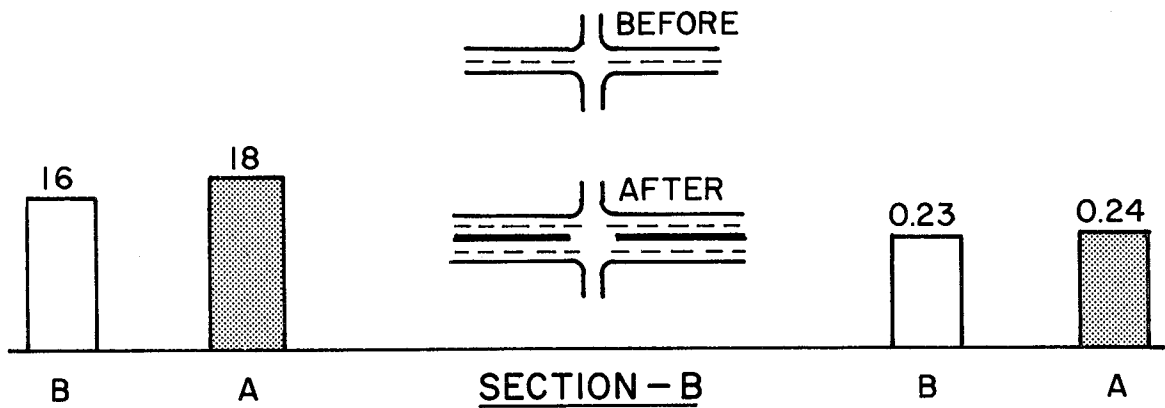

SECTION - B

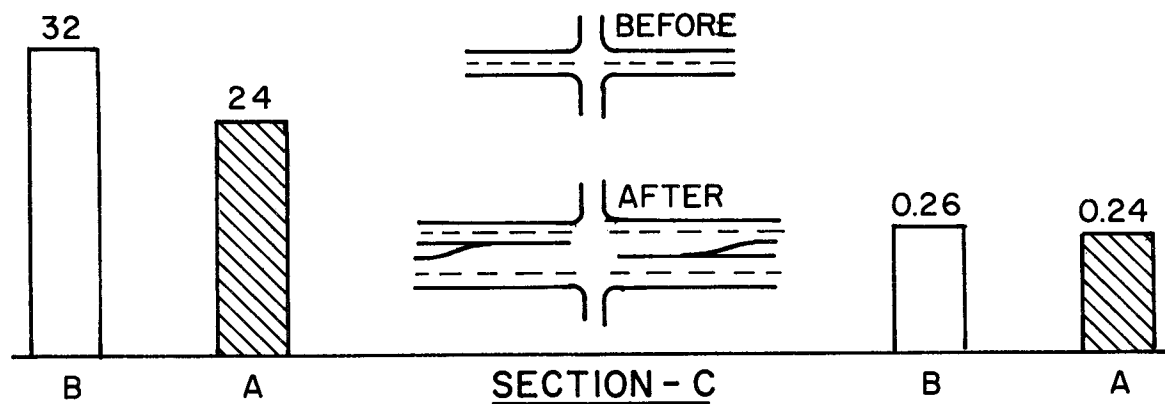

SECTION - C

**COMPARISON OF ACCIDENT PERSONAL INJURIES**

FIGURE 15

DAMAGE

DAMAGE / ACCIDENT

LEGEND  
B-BEFORE  
A-AFTER

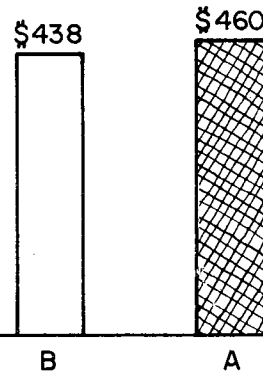
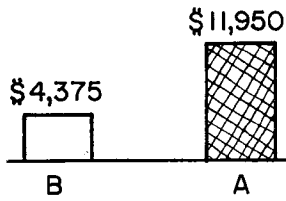
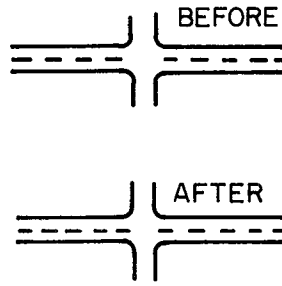

SECTION - A

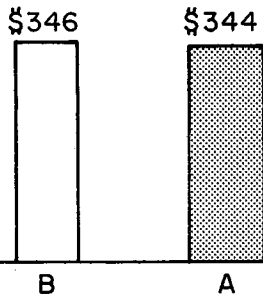
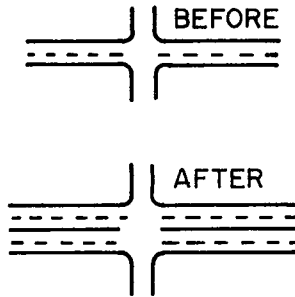
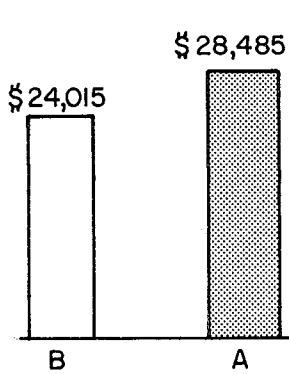

1-FATALITY BEFORE & 1-AFTER

SECTION - B

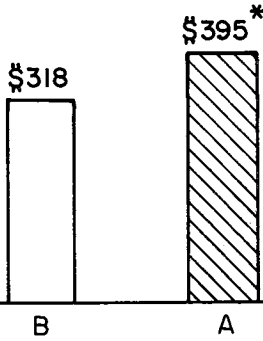
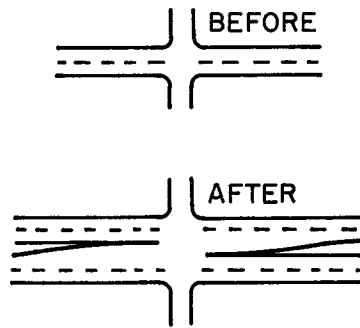
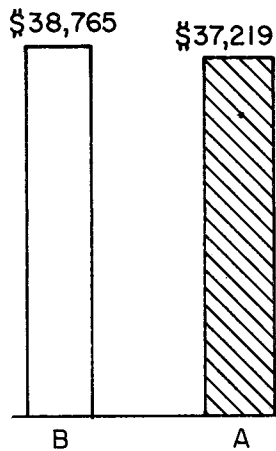

1-FATALITY AFTER

SECTION - C

\* REPORTED ACCIDENTS ONLY, DOES NOT INCLUDE 22 "KEEP RIGHT" SIGN ACCIDENTS AT \$40 EACH

**COMPARISON OF PROPERTY DAMAGE**

FIGURE 16



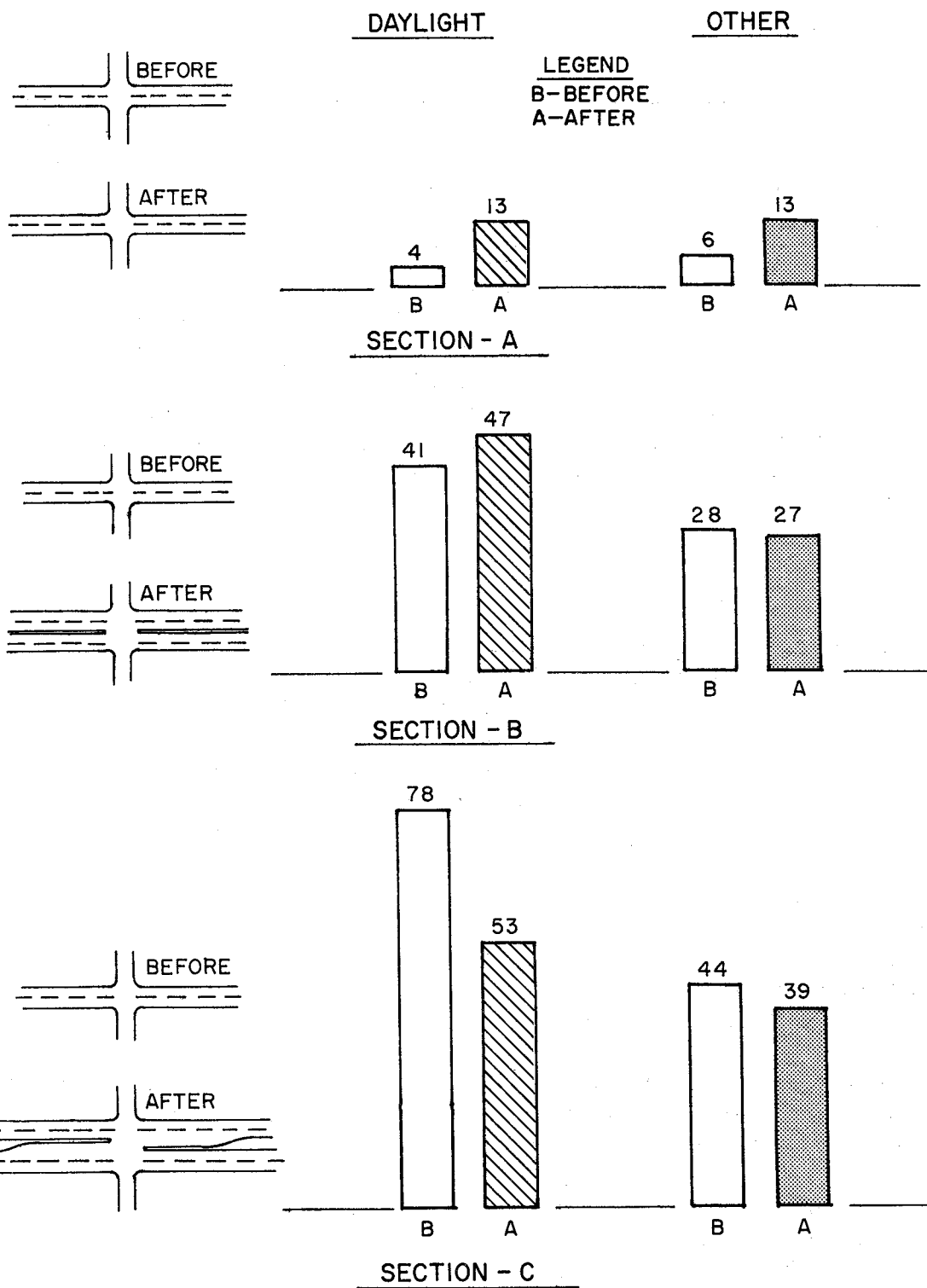

COMPARISON OF ACCIDENTS BY LIGHT CONDITIONS

FIGURE 17

## Light Conditions

A comparison of accidents by light conditions for each of the three sections is shown in Figure 17. The light conditions are broken down into two groups-- (1) daylight, and (2) other light conditions, such as dawn, dusk, and street lighting. In the section that remained in two-lane operation throughout the entire study (Section A), appreciable increases in the number of accidents were observed for both "daylight" and "other" conditions. In Section B, which operated as four-lane and unchannelized in the after study, there was no appreciable difference in the numbers of accidents occurring in each of the two study periods. However, it was observed that a greater number of accidents occurred during "daylight" than in "other" light conditions. This characteristic was not observed in Section A. In Section C, which was channelized during the after period, there was a decrease in daylight accidents during the after period, but there was no appreciable difference in the comparison for other light conditions.

## Summary of Results

The results of this research showed that there was a reduction in the total number of accidents and in the accident rate (accidents per 100 million vehicle miles) due to the introduction of channelization. When these reductions were compared to increases observed in sections which remained two-lane, unchannelized for both periods of study, the results were very significant in favor of channelization. Similarly favorable results were found when the accident statistics were further classified by day and night conditions and by "Rear-end" and "Nonintersection" collision.

In the comparison of accidents by specific type, there was a significant reduction in rear-end accidents but a substantial increase was observed in fixed object collisions. It is significant to note, however, that all of this increase was attributed to striking "KEEP RIGHT" signs on the channelizing islands.

A significant reduction in personal injuries was observed in the channelized sections. However, there was virtually no difference in the personal injury rate, that is, personal injury per accident.

As a result of this research, it was concluded that the introduction of channelization at major intersections reduces accidents and thus improves the safety of traffic operation in those areas.

A STUDY OF THE VISUAL PERSPECTIVE OF CHANNELIZATION  
AND OTHER ROADWAY FEATURES

In another phase of the research an attempt was made to study the relationships between the visual perspective aspects of channelization and the profile of the approach roadway. In this regard, a computer program was prepared to accept station, elevation, and offset data from design plans and transform them into a perspective view of the roadway ahead of the driver.

The results of this endeavor, summarized herein, are presented in greater detail in Research Report Number 19-3, "A Computer Technique for Perspective Plotting of Roadways."

This phase of the research was prompted by difficulty encountered by the designer in visualizing what will confront the driver from plan and profile drawings. There are numerous installations of channelization in use today that appeared to be completely adequate at the design stage, but reflected certain deficiencies after they were completed and opened to traffic. An excellent example is the intersection on perfectly flat topography. To the designer there are no sight distance problems and hence no visibility problems, but to the driver, features such as channelization and markings, and even the intersecting roadway do not effectively present themselves because of the flat angle from which they are viewed by the driver. To the driver the most desirable intersection layout is at the bottom of a slight grade where the total picture is presented at a high relative viewing angle, and the most undesirable situation is one in which an intersection is just beyond a gentle crest vertical curve. Somewhere in between is the minimum acceptable design. Thus, the objective of this phase of the research was to develop some economical means by which the designer could view his design from the driver's point of view.

Designers have long recognized the need to view their designs prior to construction. Models of complex interchanges have been constructed to satisfy this need, but models are expensive and generally cannot be justified for extensive application. For the less complex design applications the perspective drawing can be an effective alternate. However, several perspectives on each approach to an intersection could be expensive and time-consuming, unless manual means of drawing were replaced by more modern techniques.

A fast and effective means of preparing perspective views would be a versatile designer's tool. It would conceivably have applications in general roadway design, interchange design, and in the location of signs and other traffic control devices for greatest effectiveness.

## General Concepts

The basic concepts of the study are fundamental in nature, employing elementary geometry and highway engineering principles. The visual description of the roadway in perspective as the driver sees it is produced by projecting selected points from a three-dimensional roadway onto a common two-dimensional reference plane as shown in Figure 18. The selected points, represented by X and Y coordinates on the two-dimensional reference plane, are joined to represent the driver's visual input.

The basic algorithms of this plotting scheme were devised for computer use for a number of reasons. First, there are numerous calculations to be made to align both the roadway and the driver, and the digital computer provides an accurate and extremely fast method of performing these calculations. Also, a large amount of design data is needed to describe the roadway accurately and the computer is capable of storing these data and selecting the proper data at the appropriate time. The scheme also gives the engineer the flexibility to study many designs using the same basic algorithms, and if changes are necessary, the data may be quickly and easily altered to provide the changed parameters. A digital plotter used in conjunction with the computer provides an expedient method of converting the calculated answers into a visual image of the roadway as though viewed at any selected point or points along the roadway, thus the designer will be permitted to check his designs to determine whether they satisfy the requirements for safe traffic operations.

The computer program uses conventional engineering procedures in its operation. First, a reference line and convenient incremental stationing are established. Then various elements of the roadway are described as in surveying practices using station, elevation, and perpendicular offset from the reference line. Any number of continuous lines or discrete elements such as signs, bridges, etc. may be represented in this manner.

The program has the capability of preparing its own elevation data for vertical curves. For this operation it is only necessary to furnish the program with (1) the station of the intersection's two grades, and (2) the appropriate K value, the rate of curvature as described in various design manuals.<sup>7</sup> The program then computes the required length of curve, establishes the VPC and VPT, and computes the elevations of the curve at each station.

Horizontal alignment is handled in much the same manner as vertical alignment. The program is furnished curve data including the station and angle of intersection of the two tangents, and the degree of curvature. The computer then calculates the length of curve and, for purposes of the plotting routine, relates the points on the curve to a pre-selected reference line.

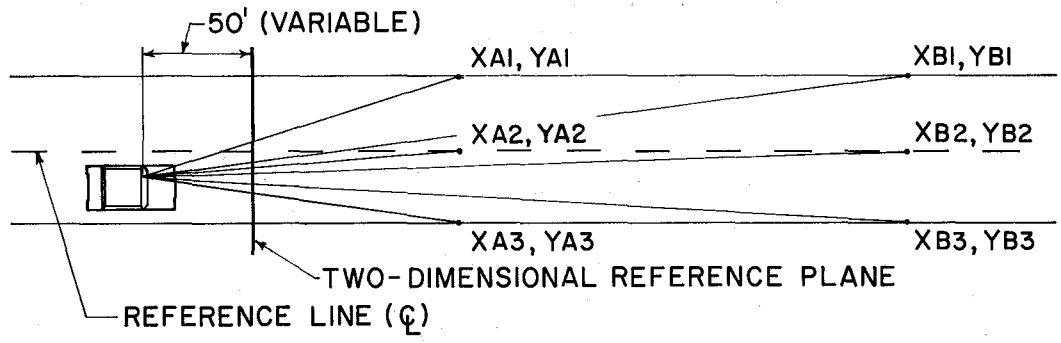

PLAN

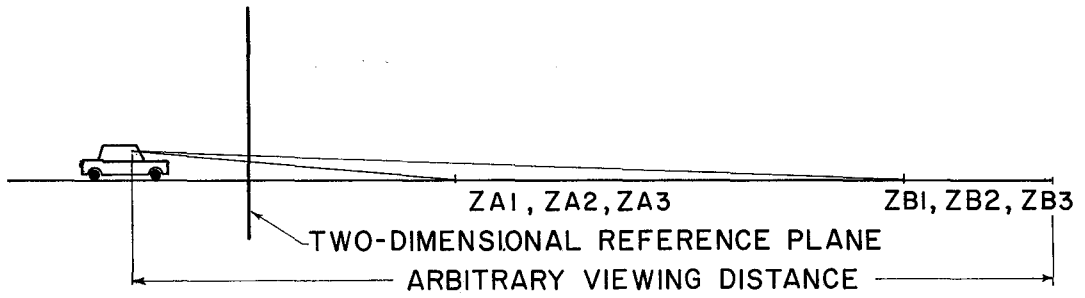

PROFILE

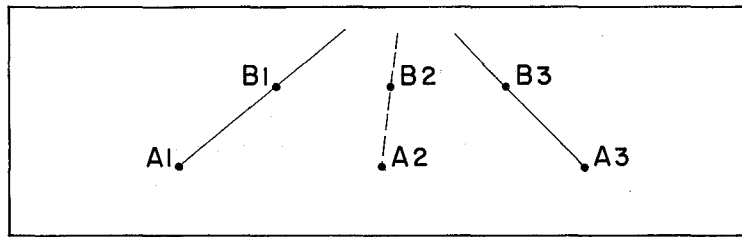

TWO-DIMENSIONAL REFERENCE PLANE

PERSPECTIVE

GENERAL CONCEPT OF PERSPECTIVE  
PLOTTING PROGRAM

FIGURE 18

Sight distances for both horizontal and vertical alignment are checked by the computer to ascertain limiting conditions such as crest curves and lateral obstructions. These limiting conditions are determined on the basis of an arbitrarily selected length of roadway which is to be plotted. In the case of vertical alignment, the limiting conditions are determined by successive comparison of vertical angles between the driver's line of sight to a point and a horizontal plane through the driver's eye. As this angle is computed for successive stations, it is compared to the angle for the previous station and noted as to whether the angle is increasing or decreasing (increasing when the point is above and decreasing when the point is below the horizontal plane). A limiting point has been reached when there is a reversal in this comparison.

For obstructions to horizontal sight distance, a description of these obstructions in X and Y coordinates; is provided and the program compares the obstruction to the driver's line of sight to each station point on the roadway within the arbitrarily selected length of roadway to be plotted. This phase of the program constitutes the sub-routine which plots signs and other objects in relation to the total roadway.

### Application

The computer program and the supporting sub-routines operate on the IBM 7094 digital computer at the Data Processing Center of Texas A&M University. The 7094 uses the program and input data to prepare the output data on magnetic tape. The magnetic tape then serves as input for an IBM 1401 digital computer which is linked to a Cal Comp Model 565 digital plotter. The digital plotter prepares the perspective views with incremental accuracy of 100th of an inch in both X and Y directions.

Running time for the program is nominal, especially when considered in comparison with the amount of output. At present, approximately three minutes of computer time and four minutes of digital plotter time are required to calculate and draw twenty perspective views of a typical roadway. However, it is believed that this time could be reduced substantially by further refinement of the program.

Typical highway plans were obtained from District 17 of the Texas Highway Department to provide data for testing of this program. The intersection of F.M. 60 and F.M. 2513 is typical of a number of sites selected for testing purposes. Input data for the computer program were prepared from the plans and the results of the various plotting routines are shown in Figures 19 through 24.

Figure 19 is a plan view of a section of F.M. 2513 approaching the intersection with F.M. 60. All line work is exactly as produced by the plotter without retouching to eliminate incremental changes in the plotting pen. It should be pointed out that the variation in road width indicated in Figure 19 is only apparent due to difference in horizontal and vertical scale. In order that the entire length of roadway selected for successive perspective views

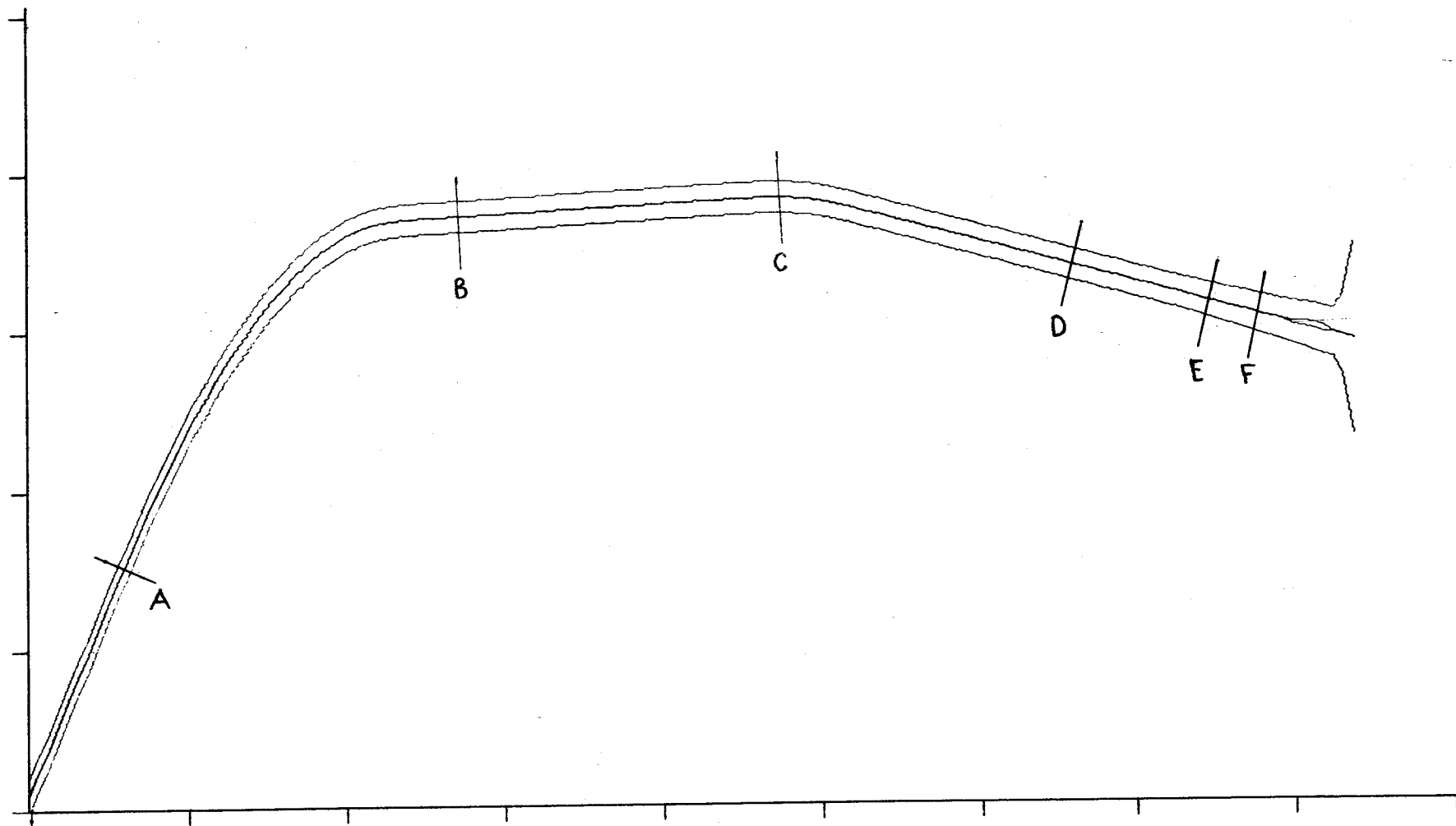

PLAN VIEW INTERSECTION FM 60 - FM 2513  
Driver Position for Perspective Views Indicated

Vertical Scale 1" = 100'  
Horizontal Scale 1" = 400'

FIGURE 19

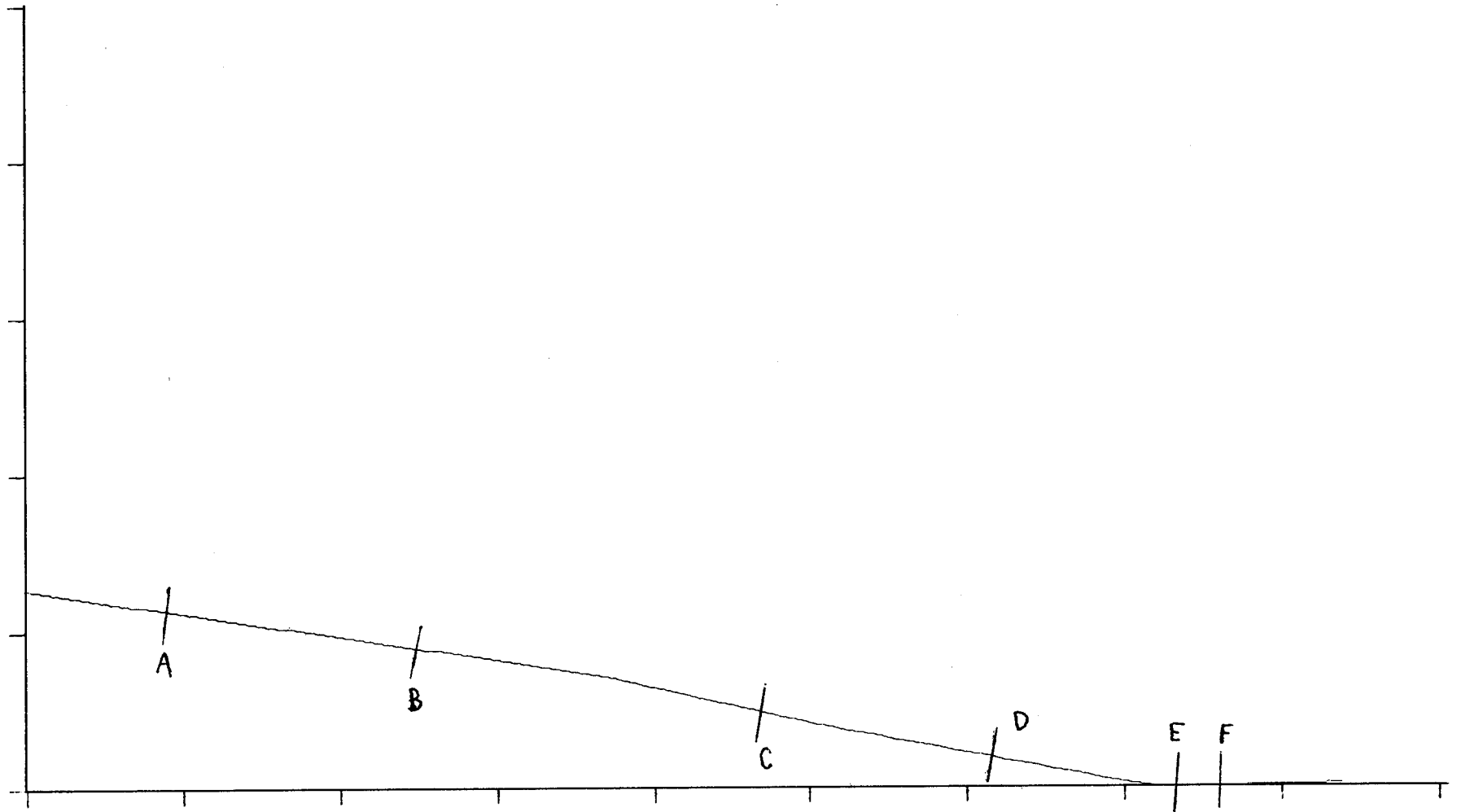

PROFILE VIEW INTERSECTION FM 60 - FM 2513  
Driver Position for Perspective Views Indicated

Vertical Scale 1" = 20'  
Horizontal Scale 1" = 400'

FIGURE 20



could be reduced to report size, the horizontal scale was set at one inch equal to 400 feet while the vertical scale was one inch equal to 100 feet. In actual practice, identical scales would be selected to provide realistic plotting. The points A through F in Figure 19 indicate driver positions for the various perspective views prepared and presented in subsequent illustrations.

Figure 20 shows the profile view of the test section as prepared by the program and the plotting routine. Both the plan and profile views are sub-routines to the main plotting program.

Figure 21 presents two views on curves approaching the intersection. In both cases, the maximum viewing distance considered pertinent to the driver was established at 800 feet. This distance was arbitrary and there is complete flexibility in the selection of viewing distance.

In Figure 22, View C shows the roadway within the 800-foot viewing distance from a point on the curve. In Views A, B, and C, it should be noted that the viewing direction of the driver is always along the longitudinal axis of the automobile. In a curve such as in View C, the viewing direction would change as the position of the vehicle changes within the curve. View D (Figure 22) is a 750-foot viewing distance which includes the intersection. All signs and channelization are included. In View D the divisional island appears to be rather insignificant but the two "KEEP RIGHT" signs on the island are readily visible. In View E, (Figure 23) which shows the intersection from a viewing distance of 350 feet, the channelizing island has taken on more significance and in View F, a complete view of the island is provided the driver.

It is believed that application of the program in conjunction with the design of intersections and approaching roadways would help the designer in controlling the approach profile to improve the visibility aspects of the intersection.

The program was also used in an attempt to study delineators placed on channelizing islands. A sample of this plotting work is shown in Figure 24. Six-by-six-inch delineators were placed along the channelizing island for nighttime visibility. The size and location of these delineators were described in data form to the program and the perspective views illustrated were produced. These particular views are not indicative of what the driver actually sees at night. Difficulty was encountered in attempting to produce what the driver sees at night when the relative importance of small objects such as delineators is much greater than their actual physical dimensions. To obtain a realistic picture, it would be necessary to incorporate in the program some measure of the relative reflectiveness of the delineators in relation to other objects of the roadway, and time did not permit the development of this technique, although several unsuccessful attempts were made.

This work on the perspective plotting program was only partially completed at the termination of the project. The work was completed as a thesis subject<sup>6</sup> by Mr. Ross A. Park, a graduate student in computer science. As a thesis subject, the perspective plotting routines were generalized for application to general highway design rather than specifically for channelization and delineation.

Preparation of the computer program was considerably more time consuming than originally anticipated and therefore, only a limited amount of application could be made before termination of the project. It is believed, however, that there is potential in the general concept, and additional work in this area would produce a useful and versatile design tool.

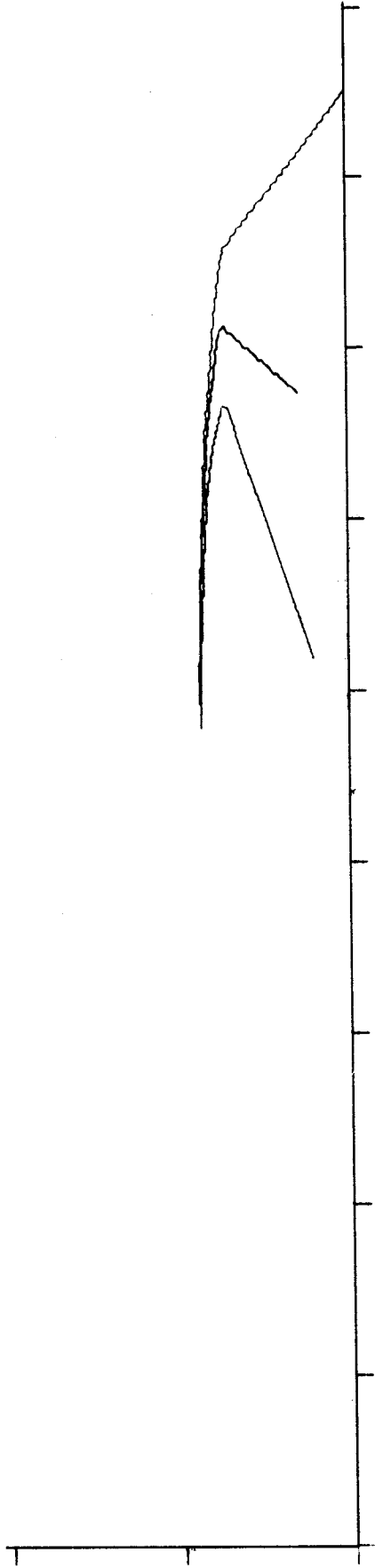

VIEW A 800 FEET CURVE 5° FM 2513

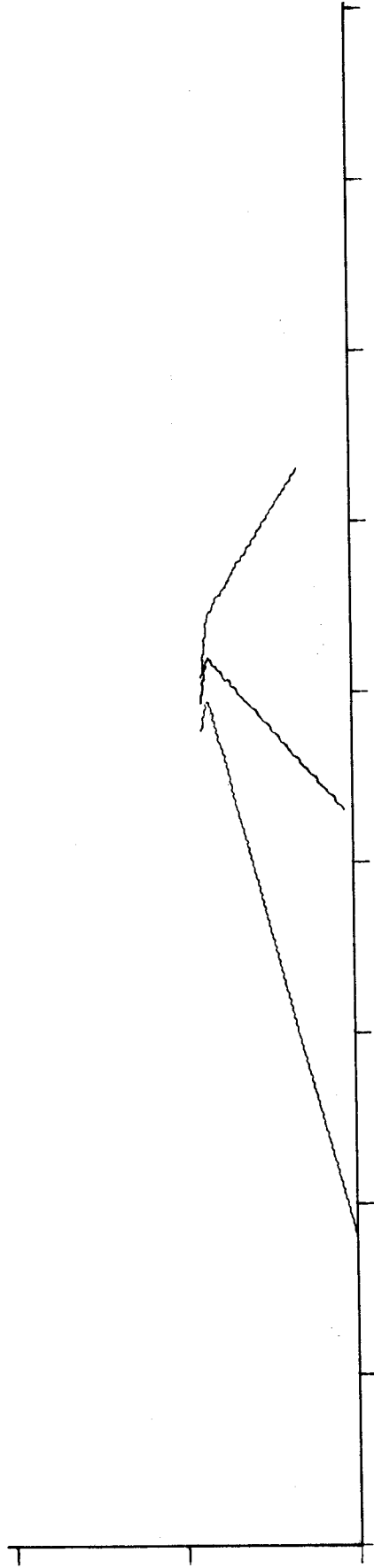

VIEW B 800 FEET CURVE 2° FM 2513

FIGURE 21

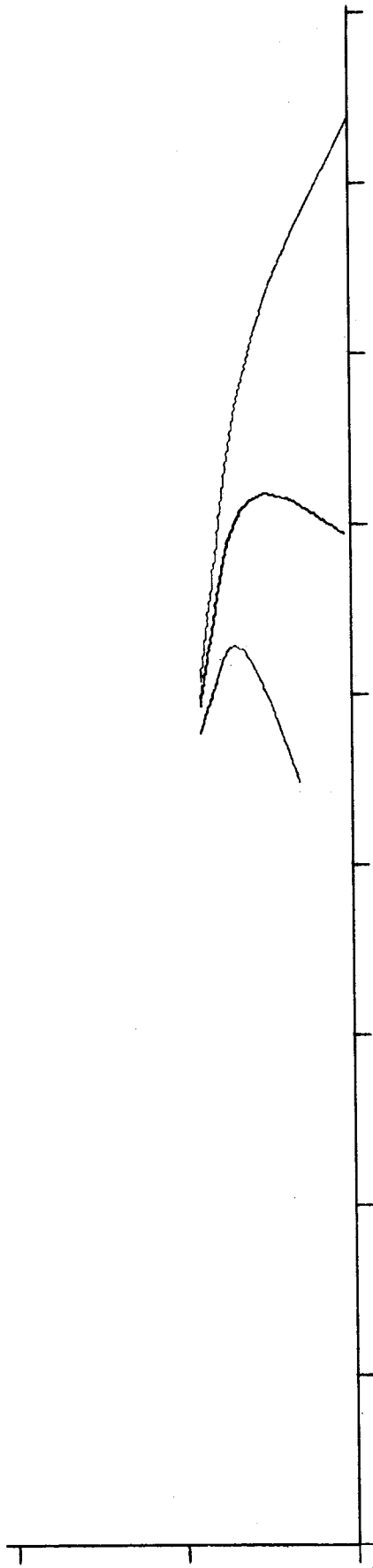

VIEW C 800 FEET CURVE 2° FM 2513

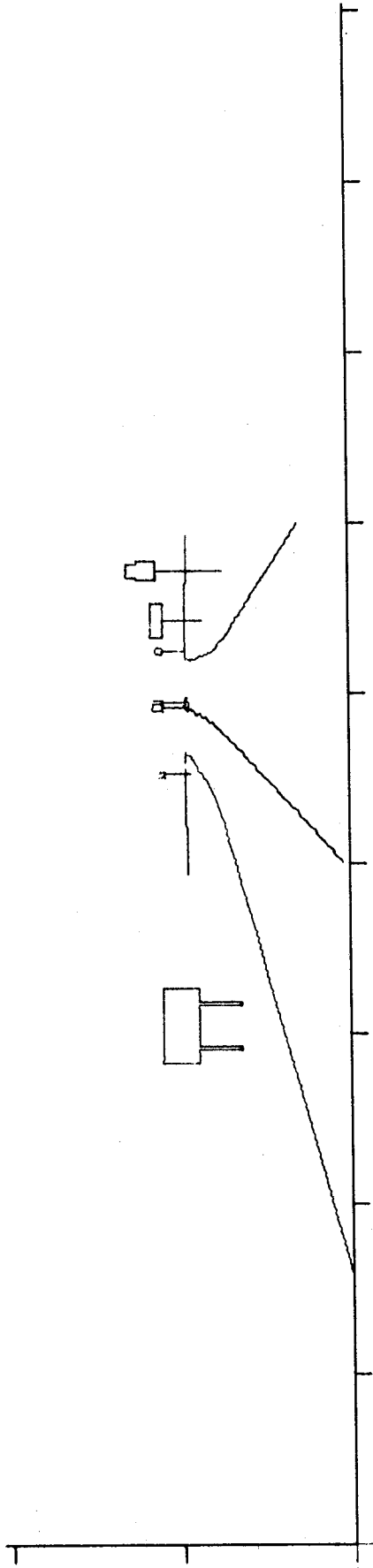

VIEW D 750 FEET INTERSECTION FM 60 - FM 2513

FIGURE 22

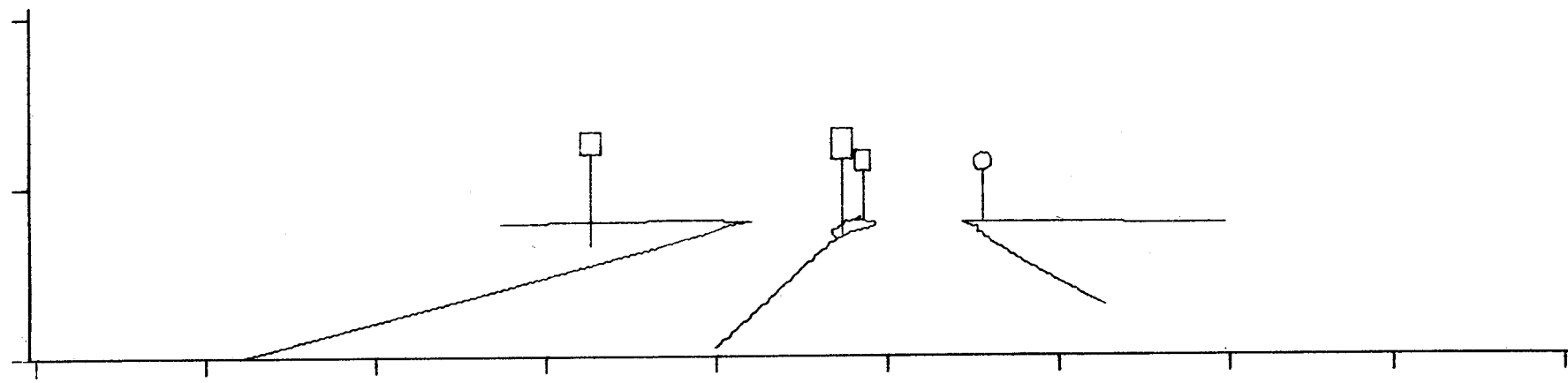

VIEW E 350 FEET INTERSECTION FM 60 - FM 2513

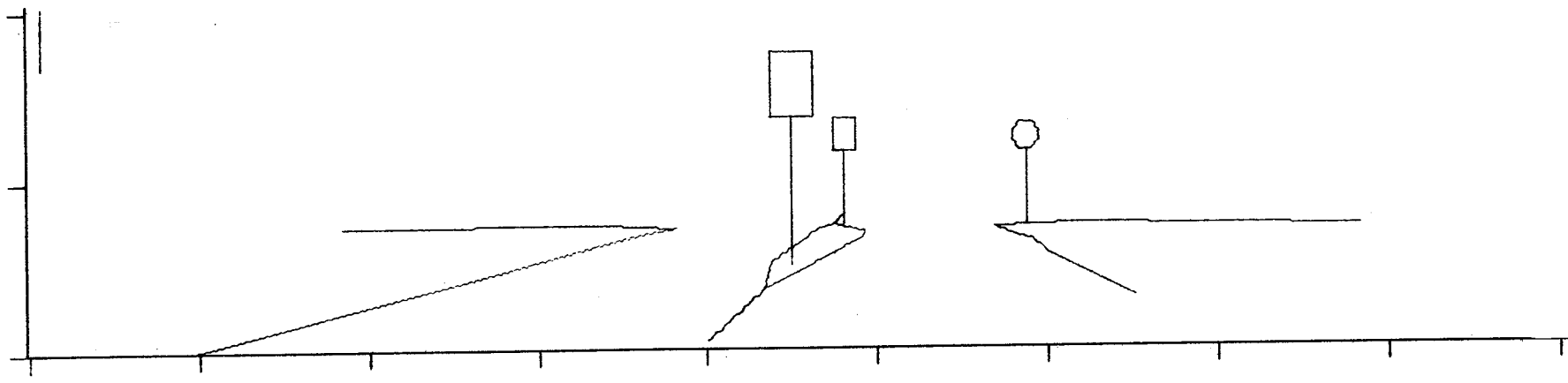

VIEW F 250 FEET INTERSECTION FM 60-FM 2513

FIGURE 23

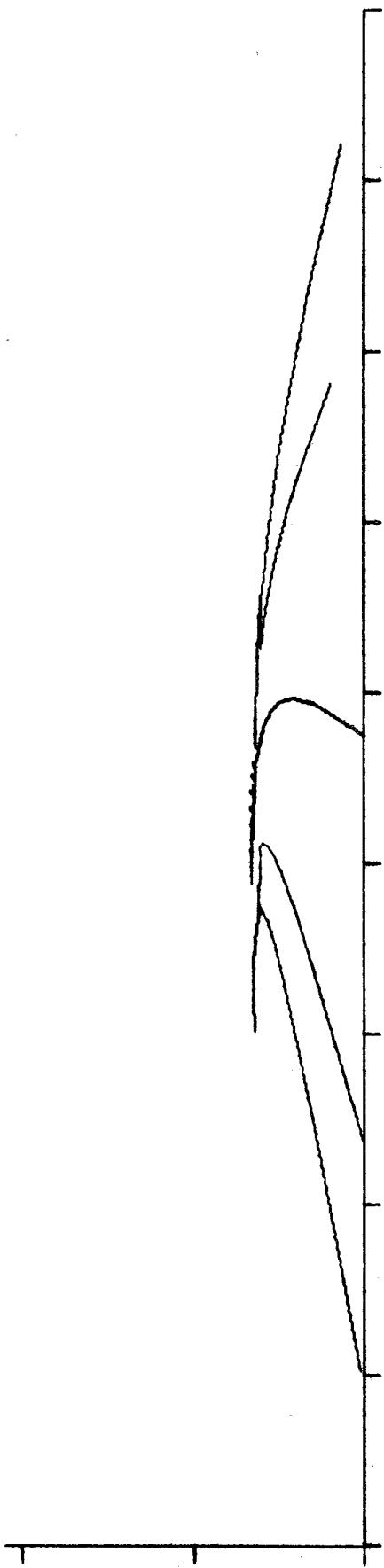

VIEW D 550 FEET CURVE 4.77° 6" x 6" DELINEATORS

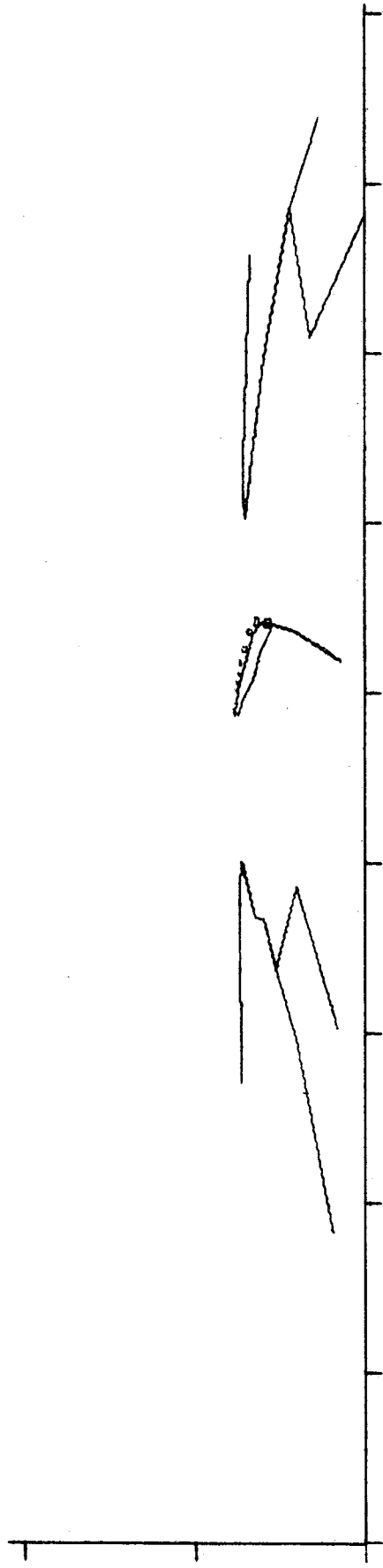

VIEW E 350 FEET CURVE 4.77° 6" x 6" DELINEATORS

FIGURE 24

## LIST OF REFERENCES

1. Manual on Uniform Traffic Control Devices for Streets and Highways. Bureau of Public Roads, U. S. Department of Commerce, Washington D. C., 1961.
2. Rowan, N. J., Approach-End Treatment of Channelization---Signing and Delineation, Highway Research Board Bulletin No. 341, 1962.
3. Rowan, N. J., Marking the Approach-Ends of Channelization. Bulletin No. 25, Texas Transportation Institute, 1963.
4. Kermit, M. L., and Hein, I. C., Effect of Rumble Strips on Traffic Control and Driver Behavior. Highway Research Board Proceedings, 1962.
5. Schmidt, Percival, and Hein. Pavement Overlays Using Polyester Resin and Asphalt Laminates. Highway Research Board Bulletin No. 300, 1961.
6. Park, R. A., Perspective Plotting of Roadway Using Design Data. Thesis, Texas A&M University, 1965.
7. A Policy on Geometric Design of Rural Highways. American Association of State Highway Officials, 1954.

