

TEXAS CRASH CUSHION TRAILER TO
PROTECT HIGHWAY MAINTENANCE VEHICLES

by

E. L. Marquis
Research Engineer

and

T. J. Hirsch
Research Engineer

Research Report 146-6
Studies of Field Adaptation of Impact
Attenuation Systems

Research Study Number 2-8-68-146

Sponsored by
The Texas Highway Department
in cooperation with
The United States Department of Transportation
Federal Highway Administration

August 1972

Texas Transportation Institute
Texas A&M University
College Station, Texas

ABSTRACT

The Texas Crash Cushion Trailer of 20 gage 55-gallon steel drums with 8 in. holes in the top and bottom with a set of wheels and a trailer hitch has been successfully tested in a head-on collision. When properly attached to a maintenance vehicle such as a dump truck it will provide protection to the maintenance vehicle, maintenance or construction personnel, and the driver and passengers of an errant vehicle. There is still a need for testing and evaluation for impacts at angles up to 10 degrees.

DISCLAIMER

The contents of this report reflect the views of the authors who are responsible for the facts and the accuracy of the data presented herein. The contents do not necessarily reflect the official views or policies of the Federal Highway Administration. This report does not constitute a standard, specification or regulation.

ACKNOWLEDGEMENTS

This study was conducted under a cooperative program between the Texas Transportation Institute and the Texas Highway Department. It was sponsored by the Texas Highway Department and the Federal Highway Administration. Liaison was maintained through Mr. John F. Nixon of the Texas Highway Department and Mr. Edward V. Kristoponis of the Federal Highway Administration.

The cooperation of Mr. Joe G. Hanover, District Engineer, and maintenance personnel, and use of equipment of District 17, Texas Highway Department, were invaluable for conducting this test. In addition, Mr. Leon Hawkins, Maintenance Engineer of the Texas Highway Department, contributed many helpful comments and suggestions. The crash test and evaluation was carried out by personnel of the Highway Safety Research Center of the Texas Transportation Institute.

SUMMARY REPORT

Wheels have been added to the Texas Crash Cushion. The resulting trailer is a workable and easily used implement for the protection of personnel and equipment, especially when performing maintenance on our nation's highways and streets. One crash test has been performed to verify the design theory. This test showed that the equations of mechanics predicted results which were very close to the test results.

The Texas Crash Cushion Trailer varies from the usual crash cushion in that the object supporting the crash cushion is itself movable rather than firmly fixed in space. This fact reduces the number of steel drums required but introduces a new variable in the form of the distance that the trailer and back up maintenance truck will travel if impacted by an errant vehicle. This variable of distance traveled after impact and the number of steel drums required are determined by introducing the equations of momentum and friction into the solution. Figure 2 in the text is a ready reference for the selection of the number of drums required for usual highway use. Figure 3 can be used to determine the minimum distance a maintenance truck-crash cushion trailer combination should trail or be parked behind personnel and equipment to afford protection. Drawings of a Texas Crash Cushion Trailer and the type of minor modifications necessary to a towing truck are included. There is a need for testing and evaluation for impacts at angles up to 10 degrees.

Key Words: Crash Cushion, Trailer, Steel Drums, Impact Attenuation, Highway Safety, 4-S Program, Structural Systems, Portable, Momentum, Kinetic Energy, Highway Maintenance Vehicles.

IMPLEMENTATION STATEMENT

The successful test conducted as described herein combined with the vast research previously accomplished and the field service record of the Texas crash cushion warrants the immediate implementation of the installation. In fact several districts of the Texas Highway Department either have built trailers or are in the process of building them. There is however a need for additional testing and evaluation for impacts at angles up to 10 degrees.

TABLE OF CONTENTS

	Page
ABSTRACT	ii
ACKNOWLEDGEMENTS	iii
SUMMARY REPORT	iv
IMPLEMENTATION STATEMENT	v
TABLE OF CONTENTS	vi
LIST OF FIGURES	vii
LIST OF TABLES	viii
INTRODUCTION	1
DESIGN OF TEXAS CRASH CUSHION TRAILER	2
Test Crash Cushion Trailer Design	8
VEHICLE CRASH TEST	12
DISCUSSION OF RESULTS	17
Test Data	17
Correlation of Test Data	25
SUMMARY AND CONCLUSIONS	27
REFERENCES	29
APPENDIX	

LIST OF TABLES

TABLE		Page
1	Test Data	21
2	Table of Events	24

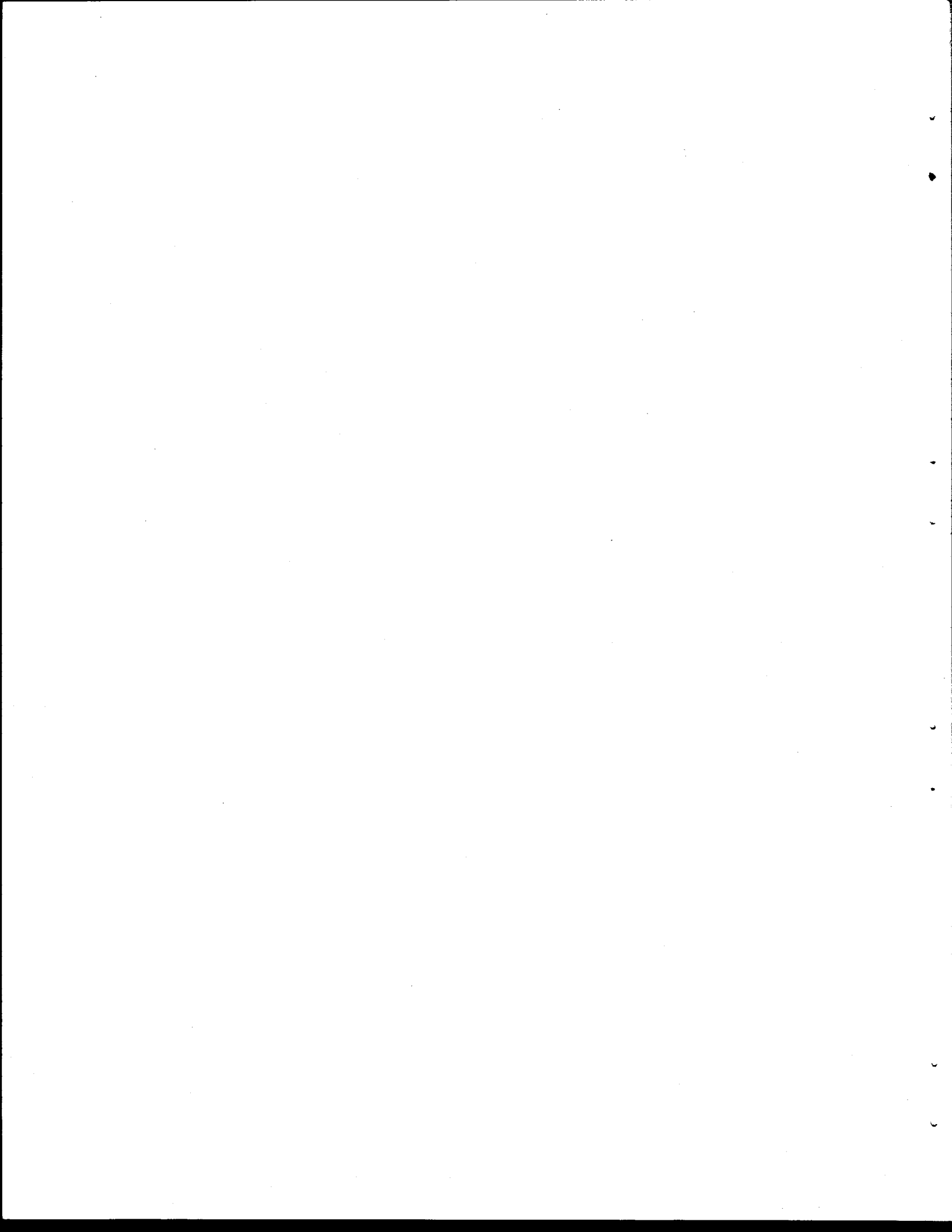

INTRODUCTION

The effectiveness of the Texas Crash Cushion in contributing to highway safety is well documented (5, 7, 8)*. Previous research and field experience with this device has been to protect an errant motorist from a high speed collision with a rigid obstacle. Common examples are elevated gores and bridge piers in median areas.

The purpose of this research was to expand the use of this energy absorbing device to a portable or mobile trailer system to protect slowly moving or stopped maintenance vehicles working on our highways. The Texas Crash Cushion Trailer (TCCT) is to be used to protect highway maintenance equipment and personnel as well as the motoring public. An important requirement of the TCCT is that it be portable or mobile and easily constructed by highway maintenance personnel and be adaptable to dump trucks and other highway department vehicles.

*Numbers in parenthesis refer to corresponding numbers in the References.

DESIGN OF TEXAS CRASH CUSHION TRAILER

The design of the crash cushion trailer is based on the law of conservation of momentum and on the dissipation of kinetic energy by plastic deformation of steel drums and through friction. This is somewhat different than the design of fixed Texas crash cushions which absorb energy by plastic deformation of steel drums only. The critical energy absorbing condition for the design of the crash cushion trailer will occur for an impact in which the automobile, crash cushion and restraining mechanism (usually a truck) are in line at the time of impact. See Figure 1.

For this condition the momentum of the automobile (or striking vehicle) before impact will be equal to the total momentum of the system immediately after impact. Assuming plastic impact

$$\frac{W_c}{g} V_c = \frac{W_c + W_b + W_t}{g} V.$$

Where

W_c = Total weight of automobile, lb.,

W_b = Total weight of the portable crash cushion, lb.,

W_t = Total weight of the truck, lb.,

V_c = Velocity of the automobile at impact, fps.,

V = Velocity of the entire system immediately after impact, fps.,

g = the acceleration due to gravity, ft./sec.²

Solving for the velocity of the entire system after impact yields

TEXAS CRASH CUSHION TRAILER

3

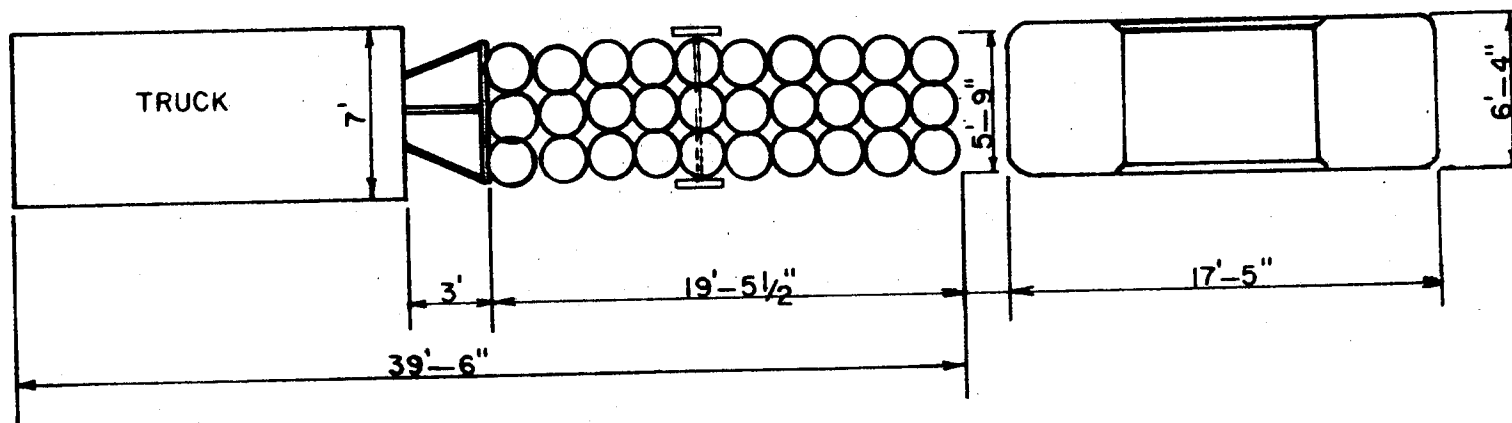

FIGURE 1 - CRASH CUSHION TRAILER BEFORE TEST

$$V = \frac{W_c}{W_c + W_b + W_t} V_c.$$

For a truck weighing 9500 lb. a portable crash cushion weighing 2000 lb. and an automobile weighing 4500 lb. and an impact speed of 60 mph (88 fps) we have

$$V = \frac{4500}{4500 + 2000 + 9500} 88 = 24.75 \text{ fps or } 16.88 \text{ mph.}$$

The kinetic energy (K.E.) of the automobile before impact is computed by the formula

$$K.E. = \frac{MV^2}{2}$$

$$K.E. = \frac{4500 \times (88)^2}{2 \times 32.2} = 541,000 \text{ ft-lb (before impact).}$$

The kinetic energy of the automobile, crash cushion and truck after impact is

$$K.E. = \frac{(4500 + 2000 + 9500) (24.75)^2}{2 \times 32.2} = 152,000 \text{ ft-lb (after impact)}$$

Consequently, 389,000 ft-lb of energy would be absorbed in the impact by plastic deformation of the steel drums in the crash cushion trailer.

According to White and Hirsch (1) a single 20 gage tight-head steel drum with 8 inch diameter holes in the top and bottom will absorb 9000 ft-lb of energy under slowly applied loads. The dynamic factor has been

shown to be 1.5 (7). Therefore each barrel will absorb 1.5×9000 or 13,500 ft-lb of dynamic energy. This would mean that the portable crash cushion would require 28.8 steel drums. The cushion would be designed with 30 barrels to achieve a rectangular configuration.

Figure 2 was developed as a design aid from the foregoing theory. The number of barrels required is plotted against the weight of the resisting truck for impacting vehicles of 2000 lb., 4000 lb., and 4500 lb. The design impact speed is 60 mph in each case. A crash cushion trailer would generally weigh within 15% of the values shown. The figure is the design vehicle weight range recommended by FHWA (2). It can serve as a tool for designing portable crash cushions as well as for a comparison of the limiting conditions.

After the barrels have deformed plastically and absorbed 389,000 ft-lb of energy there still remains 152,000 ft-lb of energy due to the entire system moving at 24.75 fps. If all of the wheels of the truck are locked, then the distance required to stop the vehicle is

$$d = \frac{\text{K.E. (after impact)}}{W_t \mu}$$

where μ is the coefficient of friction, say 0.7 for tires to concrete.

Then

$$d = \frac{152,000}{9500 \times 0.7} = 22.9 \text{ ft.}$$

Portable Crash Cushion in Motion

While the critical design for the energy absorption of the crash cushion itself will be for the stationary condition, the critical

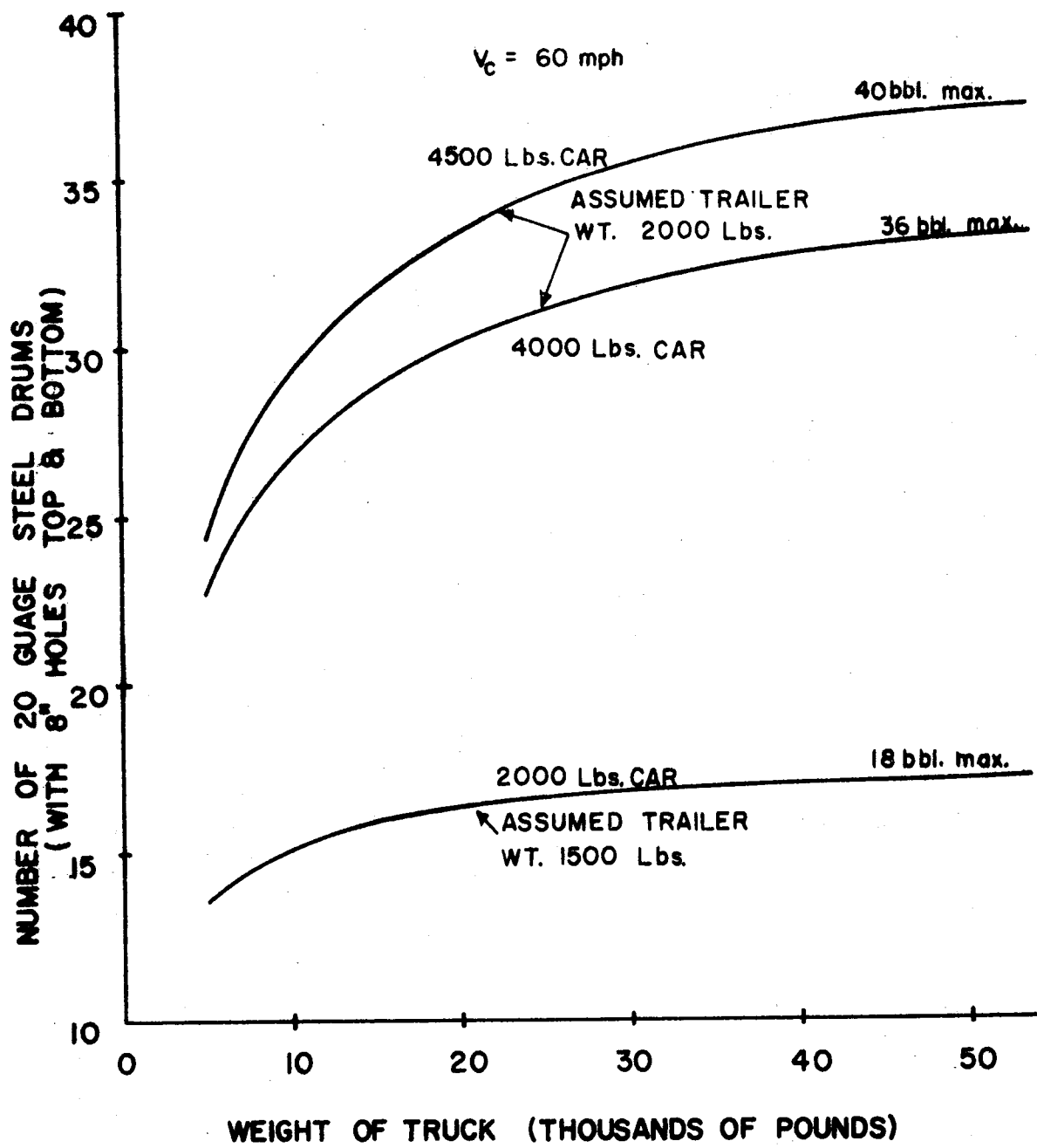

FIG. 2 - NO. OF BARRELS IN CRASH CUSHION TRAILER VS. TRUCK WEIGHT FOR SEVERAL AUTO WEIGHTS

condition for the distance traveled after impact will occur when the crash cushion and towing vehicle are in motion. Such a condition might occur in the protection of a paint stripping machine. In that instance both the impacting vehicle and the impacted assembly would have initial momentum and kinetic energy. Again assuming plastic impact and conservation of momentum

$$\frac{W_c}{g} V_c + \frac{W_b + W_t}{g} V_t = \frac{W_c + W_b + W_t}{g} V$$

or

$$V = \frac{W_c V_c + (W_b + W_t) V_t}{W_c + W_b + W_t}$$

again assuming that $V_c = 60$ mph, also that $V_t = 10$ mph for a 4500 lb vehicle and 9500 lb truck

$$V = \frac{4500 \times 60 + (2000 + 9500) 10}{4500 + 2000 + 9500} = 24.06 \text{ mph or } 35.29 \text{ fps}$$

The kinetic energy before impact

$$\text{K.E.} = \frac{4500 \times 88^2}{2 \times 32.2} + \frac{11500 \times 14.667^2}{2 \times 32.2} = 580,000 \text{ ft-lb}$$

The kinetic energy remaining after impact

$$\text{K.E.} = \frac{(4500 + 2000 + 9500) 35.29^2}{2 \times 32.2} = 309,000 \text{ ft-lb.}$$

The change in kinetic energy = 271,000 ft-lb.

Since 271,000 is less than 389,000, the stationary condition governs for plastic energy absorption. However, the stopping distance with all truck wheels locked

$$d = \frac{\text{K.E. (after impact)}}{W_t \mu} = \frac{271,000}{9500 \times 0.7} = 40.75 \text{ ft}$$

Figure 3 was developed using the above theory and a series of initial speeds of the truck-portable-crash-cushion unit.

Test Crash Cushion Trailer Design

The test design was based on an impacting vehicle weighing 4500 lb., a portable crash cushion weighing 2000 lb. and a truck weighing 9500 lb. This is the same as the sample calculated above and required 30 steel drums. The crash cushion trailer was designed to be attached to a standard maintenance dump truck of 5 cubic yard capacity. The actual truck used was Texas state equipment number 17-4664-A Dodge D-600 dump truck manufactured in 1963, the oldest truck in useable condition assigned to District 17 of the Texas Highway Department, Bryan, Texas. The actual weight of the truck at the time of the test was 9315 lb.

The design of the test portable crash cushion is shown in Figure 4. The drawbar on the truck required some minor modifications (Figure 5) to accommodate the five point hookup and the attachments were hand-fitted to the truck. These five points were considered necessary using the trailer hitch to tow the portable crash cushion to the point of use at highway speeds; and to use the remaining four points, BR, BL, CR and CL to stabilize the trailer and make it act more nearly as a unit with the towing truck when towing at low speeds or stationary. These additional

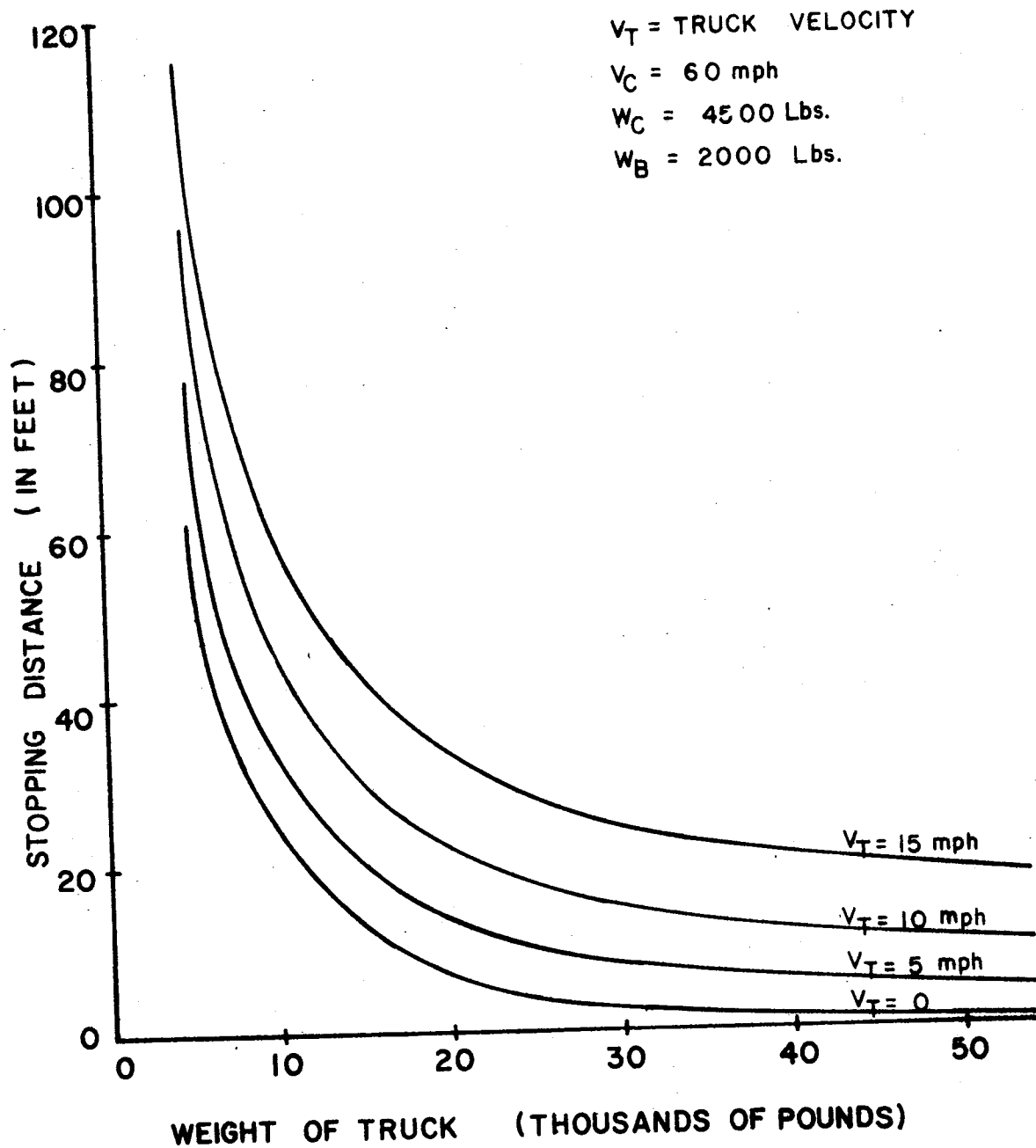

FIGURE 3 - STOPPING DISTANCE vs. TRUCK WEIGHT
 FOR VARIOUS INITIAL TRUCK SPEEDS

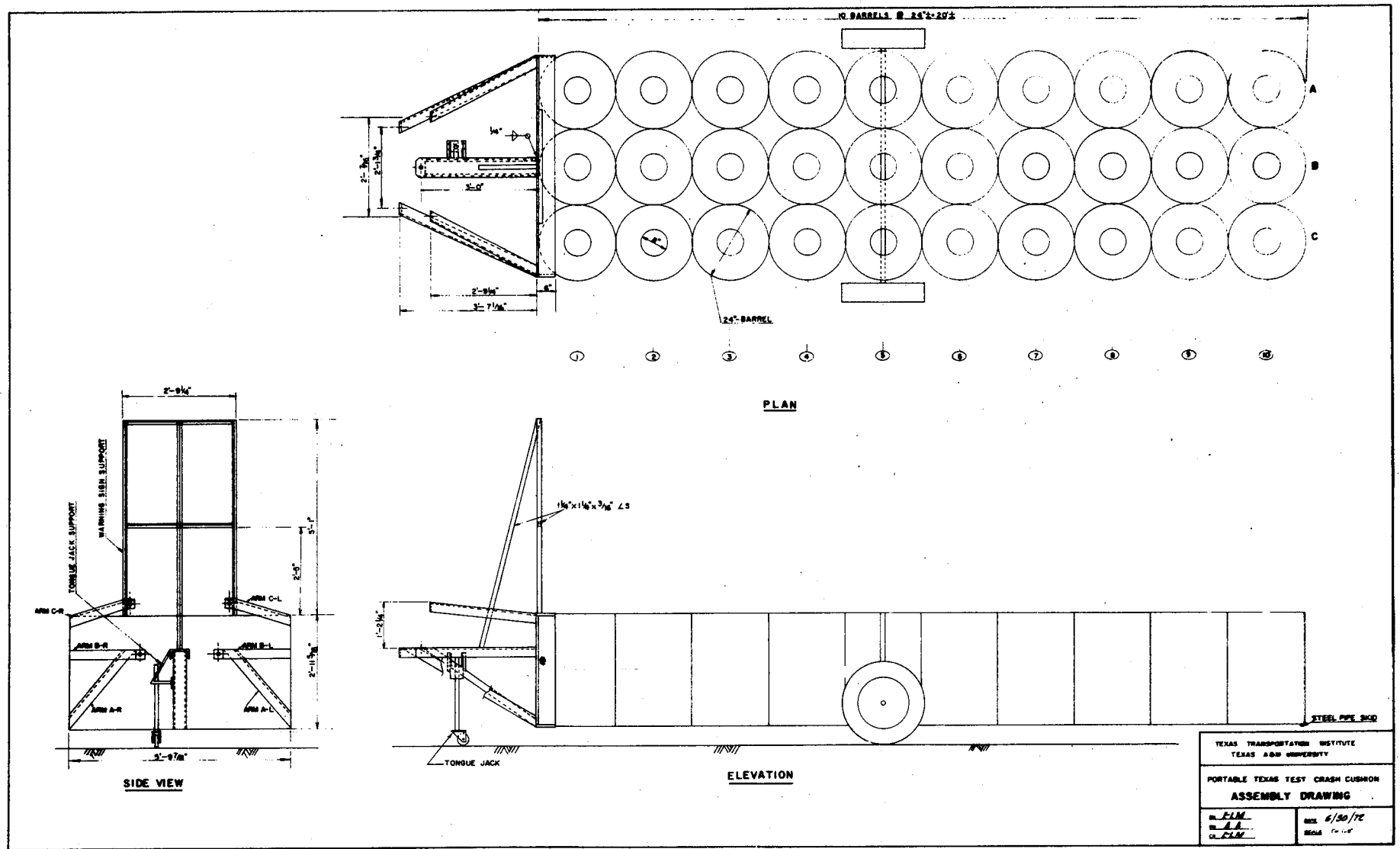

FIGURE 4 - TEST CRASH CUSHION TRAILER ASSEMBLY

TPC-1

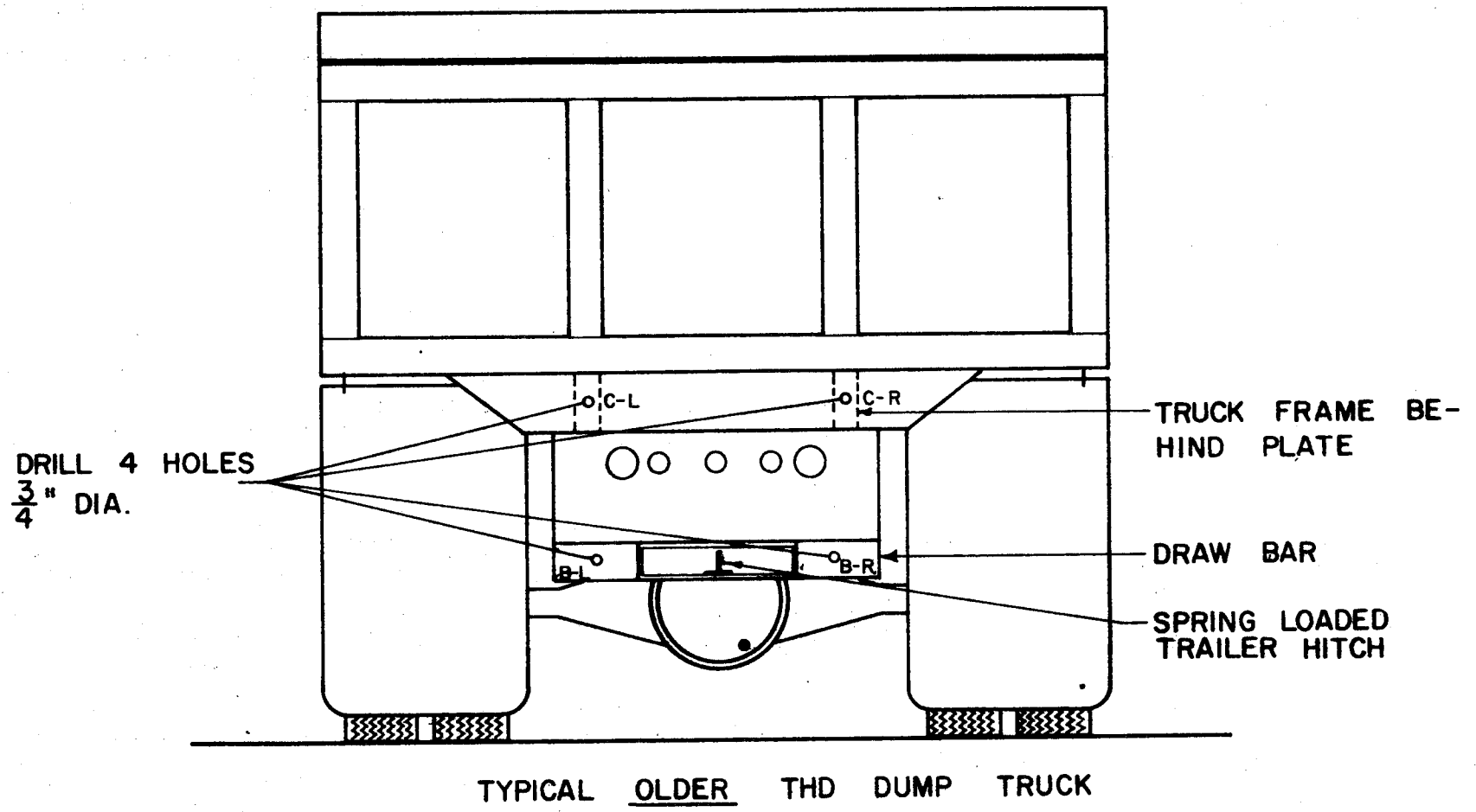

FIGURE 5 - CONNECTIONS TO TEST TRUCK

points were located to produce horizontal and vertical stability of the portable crash cushion. That is, they would not allow the trailer to jack-knife during impact and they would prevent the impacting vehicle from submarining. Pictures of the completed crash cushion trailer are shown in Figures 6 and 7.

With the exception of the removable arms all connections were welded. The four removable arms were bolted to the face of the portable crash cushion using six bolt-studs welded to the face of the crash cushion. Four bolts were used to connect the arms to the truck. Two TTI technicians pulled the portable crash cushion to the test site and made the complete hookup in less than five minutes. The addition of hinges on the side arms would decrease the time required to complete the hookup for use.

VEHICLE CRASH TEST

The crash cushion trailer was hooked to the truck, using the trailer hitch only, and towed around the TTI safety proving grounds at speeds up to 50 mph for qualitative observation. After this exercise it was noted that the steel drums connected to the trailer axle and the row directly behind the axle had slightly deformed tops. This indicated the desirability of moving the axle further to the rear of the trailer to reduce the cantilever effect of the rear steel drums. The auxillary connections were made and the trailer towed at speeds up to 25 mph around curves up to 20°. This operation was also observed qualitatively. The trailer tracked the truck to a remarkable degree considering the rigid attachment. There was, however, an abnormal amount of

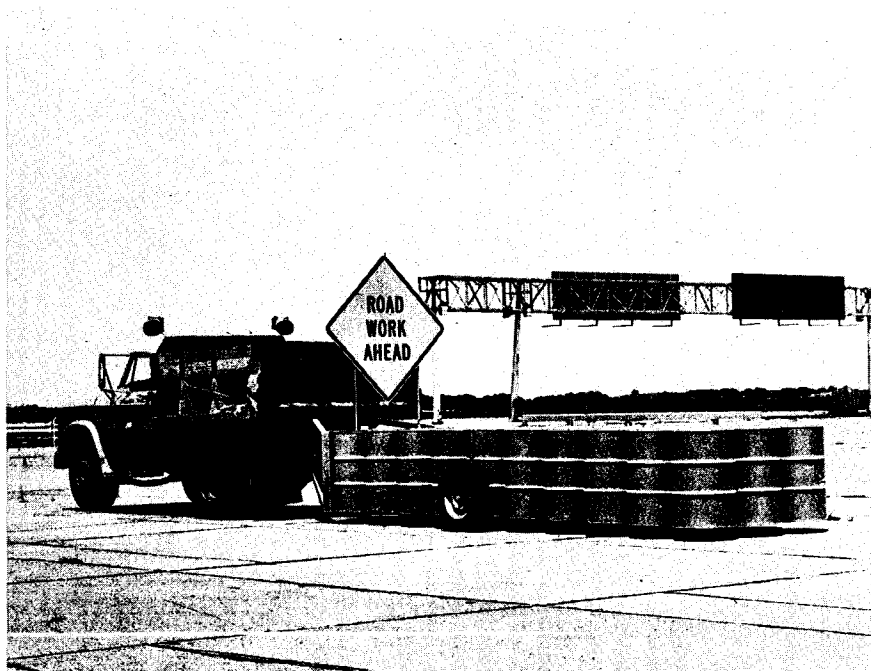

FIGURE 6 - TEST CRASH CUSHION TRAILER BEFORE

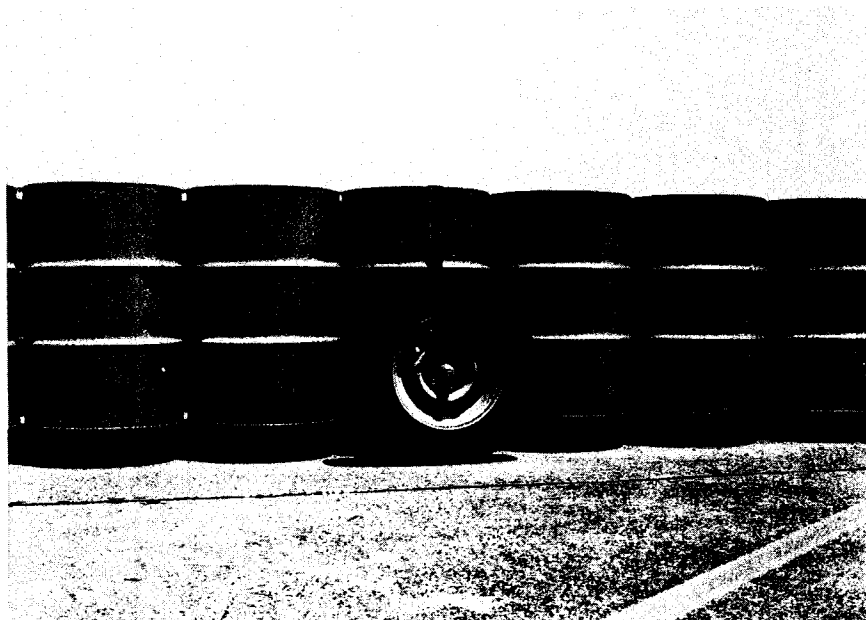
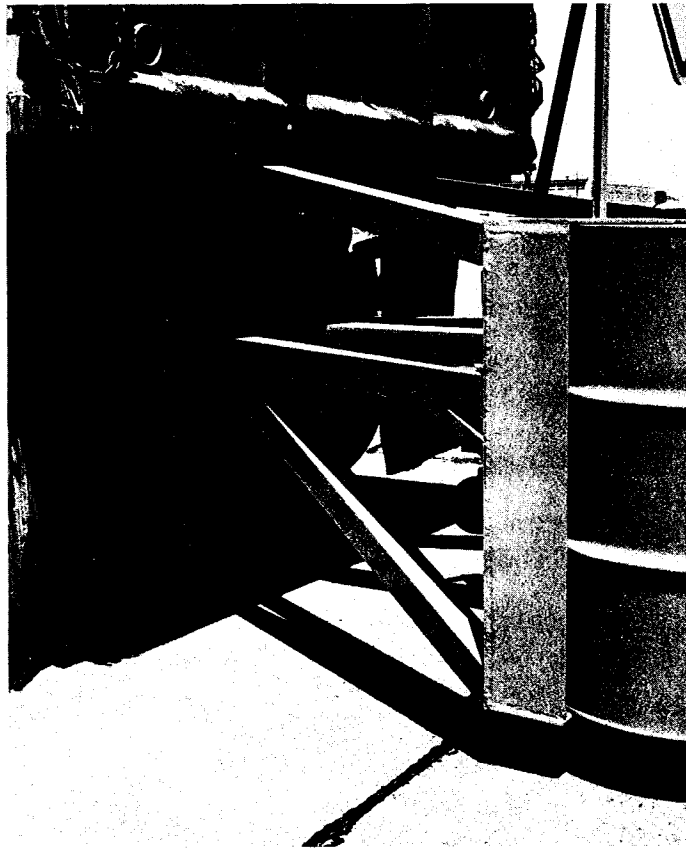
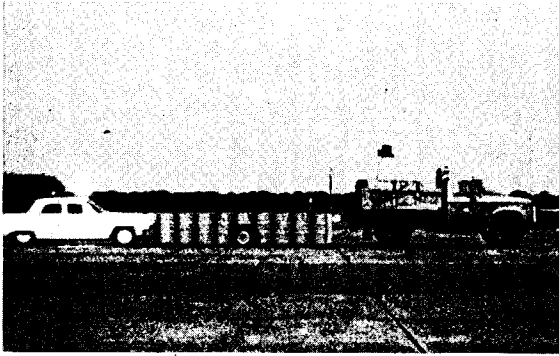

FIGURE 7 - TEST CRASH CUSHION TRAILER
TEST PCC - I CONSTRUCTION

wear to the tires due to side slippage. At lower speeds this wear was insignificant, especially when compared to the life saving potential

The primary test was the dynamic or crash test on the stationary truck-crash-cushion unit. For this test the unit was placed near the north end of the apron at the TTI safety proving grounds. Ample distance to the end of the pavement was allowed for the unit to slide after impact. The arms were bolted in place and the truck was placed in gear (ignition turned off) and the parking brake set.

The impacting vehicle was a 1964 Chevrolet weighing 4060 lb. Lateral and longitudinal accelerometers were located on the right and left frame members of the vehicle chassis. The vehicle was towed toward the target by a reverse tow-guidance system (3). The initial impact speed was 63.3 mph and the impact angle was 0° (head on) in the center of the rear end of the crash cushion trailer. Figure 8, a series of pictures from the moving picture cameras, shows the sequence of events of the test starting at impact. It is especially interesting to observe that the truck is virtually stationary until the barrels have been crushed to nearly the maximum which occurred during the test. This is important to the use of the system in the field since it shows that the majority of the energy is absorbed by the crash cushion before the energy wave reaches the truck. In turn this shows that the instantaneous peak g or jolt is at a minimum to anyone seated in the truck. It follows then that there would be little or no damage to the truck. In fact the truck was unhooked from the crash cushion trailer and given a brief examination by TTI personnel who could find no damage. The truck was then returned



a

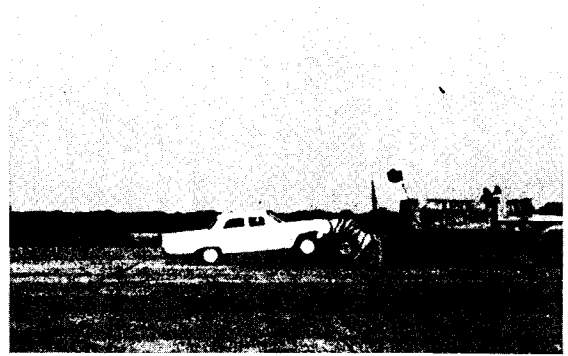

e

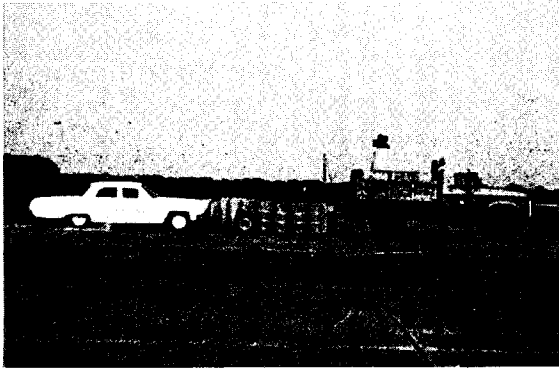

b

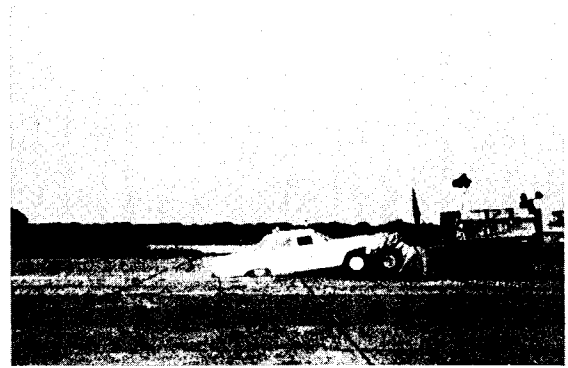

f

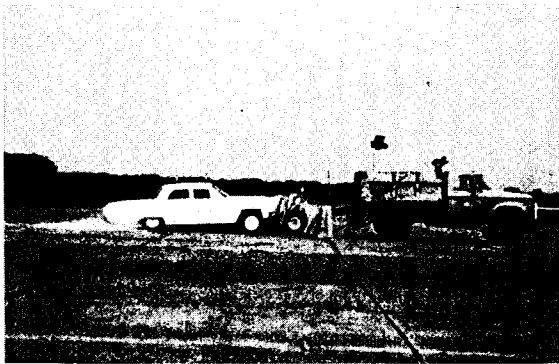

c



g

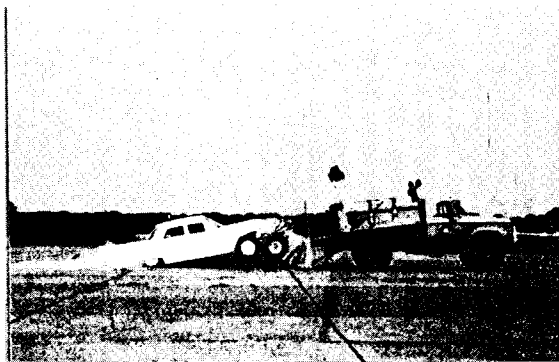

d

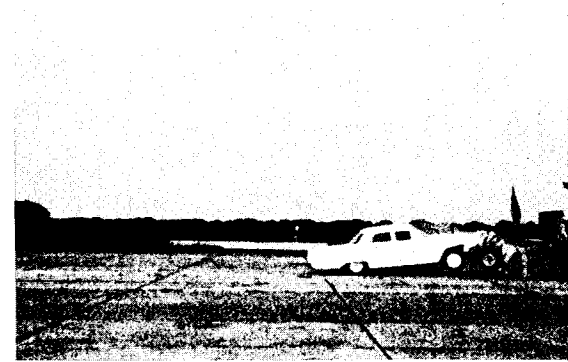

h

FIGURE 8 - TEST OF CRASH CUSHION TRAILER - PC-1

to District 17 of the Texas Highway Department. District personnel inspected the truck thoroughly. The District Engineer then wrote to the director of TTI confirming that they could find no damage to the truck (6).

Figure 9 shows the impacting automobile before and after the impact. A minimum amount of damage occurred to the vehicle. In fact only the two inside headlights were broken.

Figure 10 shows the crash cushion after the test and after the vehicle had been pried loose and driven away. Quite obviously the vast majority of the available energy of the steel drums had been used.

DISCUSSION OF RESULTS

Test Data

The data from the tests was collected from three different sources, field measurements, electronic instrumentation, and photographic instrumentation. The electronic instrumentation included an Inter-Range Instrumentation Group (IRIG) (3) with eight available channels. Two channels were used for longitudinal acceleration, two for lateral acceleration, two for speed and two spares. The data was transmitted to a central receiver where it was put on a magnetic tape and stored. The acceleration data was then filtered through an 80 hz filter and transferred with the speeds to paper tape in the visicorder. An Impact-O-Graph was used for back up data in the event of a malfunction of the IRIG.

Three high speed data cameras and two documentary cameras were used to record the test and to obtain additional data. A complete description of data reduction techniques using the Vanguard Motion Analyzer is found

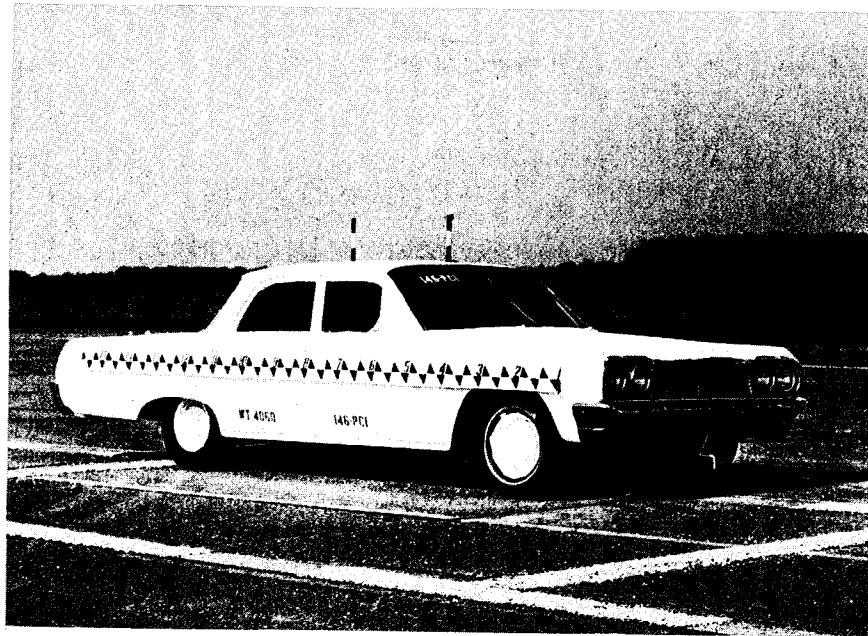

BEFORE

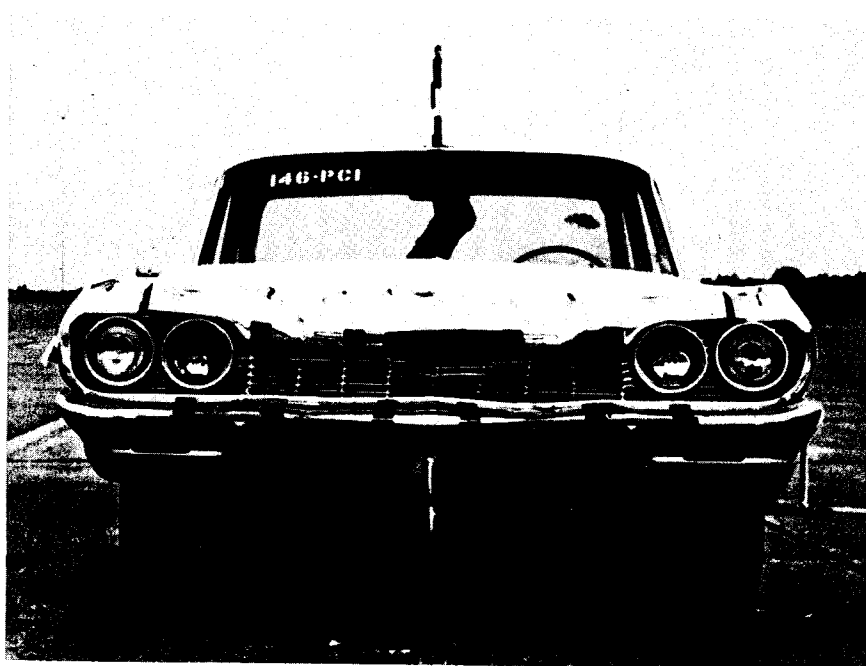

AFTER

FIGURE 9 - PC-I TEST VEHICLE BEFORE & AFTER



FIGURE 10 - CRASH CUSHION TRAILER AFTER TEST

in Appendix C to report Test and Evaluation of Vehicle Arresting, Energy Absorbing and Impact Attenuation Systems (3) published by the Texas Transportation Institute.

Table 1 presents a summary of the more important test data. There are several comparisons to the theory shown and described in detail below. There is a 1.7 ft. difference between the maximum forward motion of the vehicle and the final position of the vehicle. Of this, the truck rebounded approximately one foot, which was probably due to the movement of the truck acting against the compression of the engine. Also, the barrier and vehicle rebounded an additional 0.7 ft., indicating that there was some elasticity remaining in the barrier and the front end of the vehicle. Figure 11 graphically shows the relative final positions of the truck, barrier, and vehicle.

Table 2 presents the major events of the test with the time of occurrence for each. Figure 12 is the longitudinal and acceleration trace from the visicorder (IRIG system). The visicorder data and the table of events compare extremely well. The peak g occurs during the period when the first row of steel drums is crushed. The entire crash cushion trailer started moving forward at 211 msec. At this point the vehicle deceleration starts to increase and there is a secondary deceleration peak at approximately 275 msec., the point where the vehicle, cushion and truck move as a unit. The vehicle deceleration zeros out the first time at 366 msec., about the time the truck achieves maximum speed. After this time the acceleration trace (not shown) ranges from less than one to zero negative g's. Hence we see that the majority of the energy is absorbed in plastic deformation of the barrels and elastic

TABLE 1
TEST DATA

AUTOMOBILE

Year, Make	1964 Chevrolet
Weight	4060 lbs
Impact Angle	0 deg

TRUCK

Year, Make	1964 Dodge
Weight	9315 lbs
Crash Cushion Trailer (estimated) weight	2010 lbs

<u>EVENT DESCRIPTION</u>	<u>TEST DATA</u>	<u>COMPUTATION</u>
Initial Speed	92.8 fps or 63.3 mph	
Maximum Forward Motion of Vehicle	36.4 ft	36.8 ft
Time to End of Forward Motion	1.856 sec	
Maximum Forward Motion of Truck	21.0 ft	22.0 ft
Final Vehicle Forward Motion	34.7 ft	
Final Truck Forward Motion	20.0 ft	
Final Vehicle Deformation	0.2 ft	
Final Cushion Deformation	14.5 ft	14.8 ft
Average Deceleration, $V^2/2gS$	3.67 g's	3.64 g's
Maximum Longitudinal Acceleration	-15.2 g's	
Average Longitudinal Acceleration to End of Significant Peak	-6.6 g's	
$\frac{\Delta V}{\Delta t}$ (to 0.366 sec)		5.8 g's

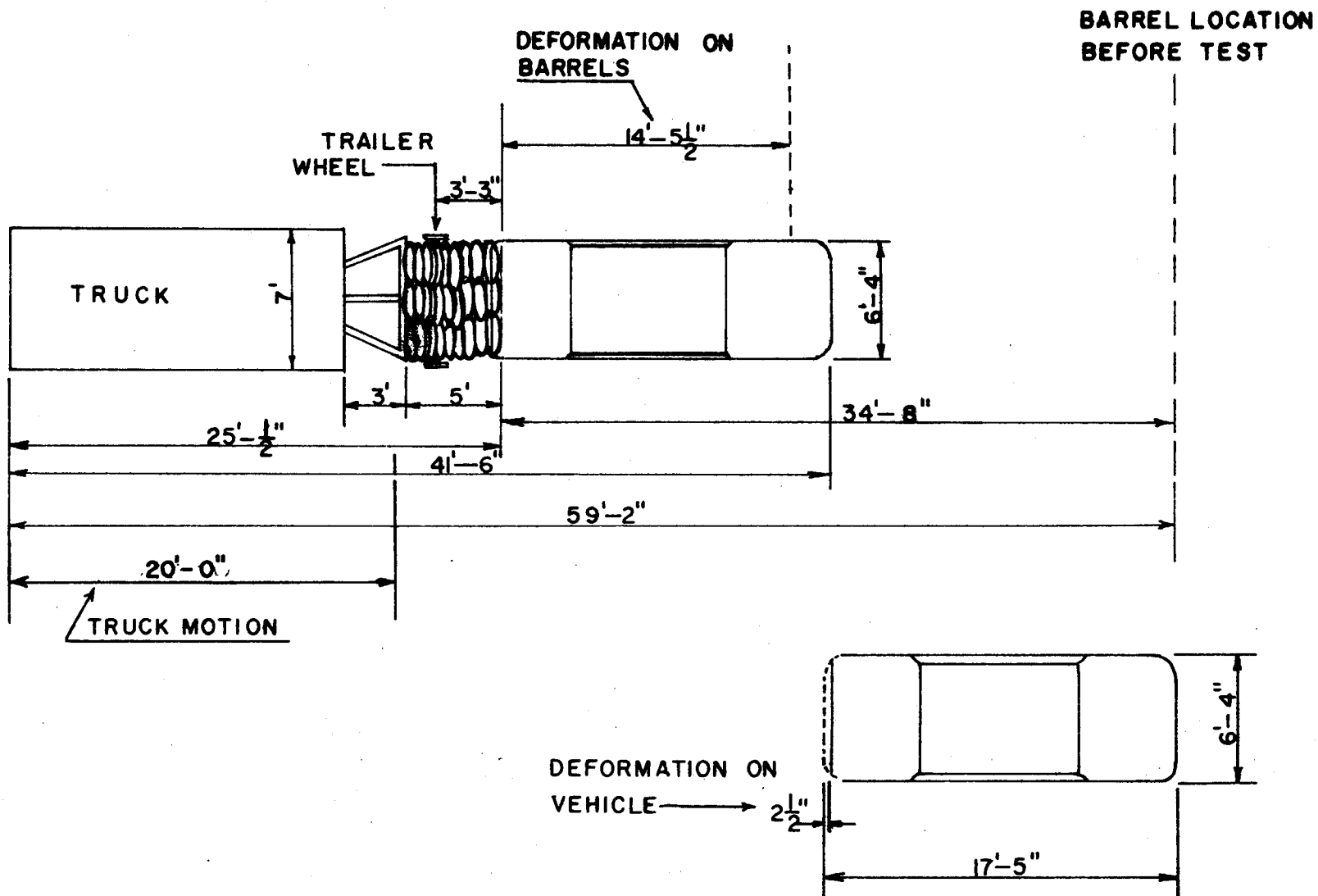

FIGURE 11 - DIAGRAM OF CRASH CUSHION TRAILER, TRUCK, AND VEHICLE AFTER TEST

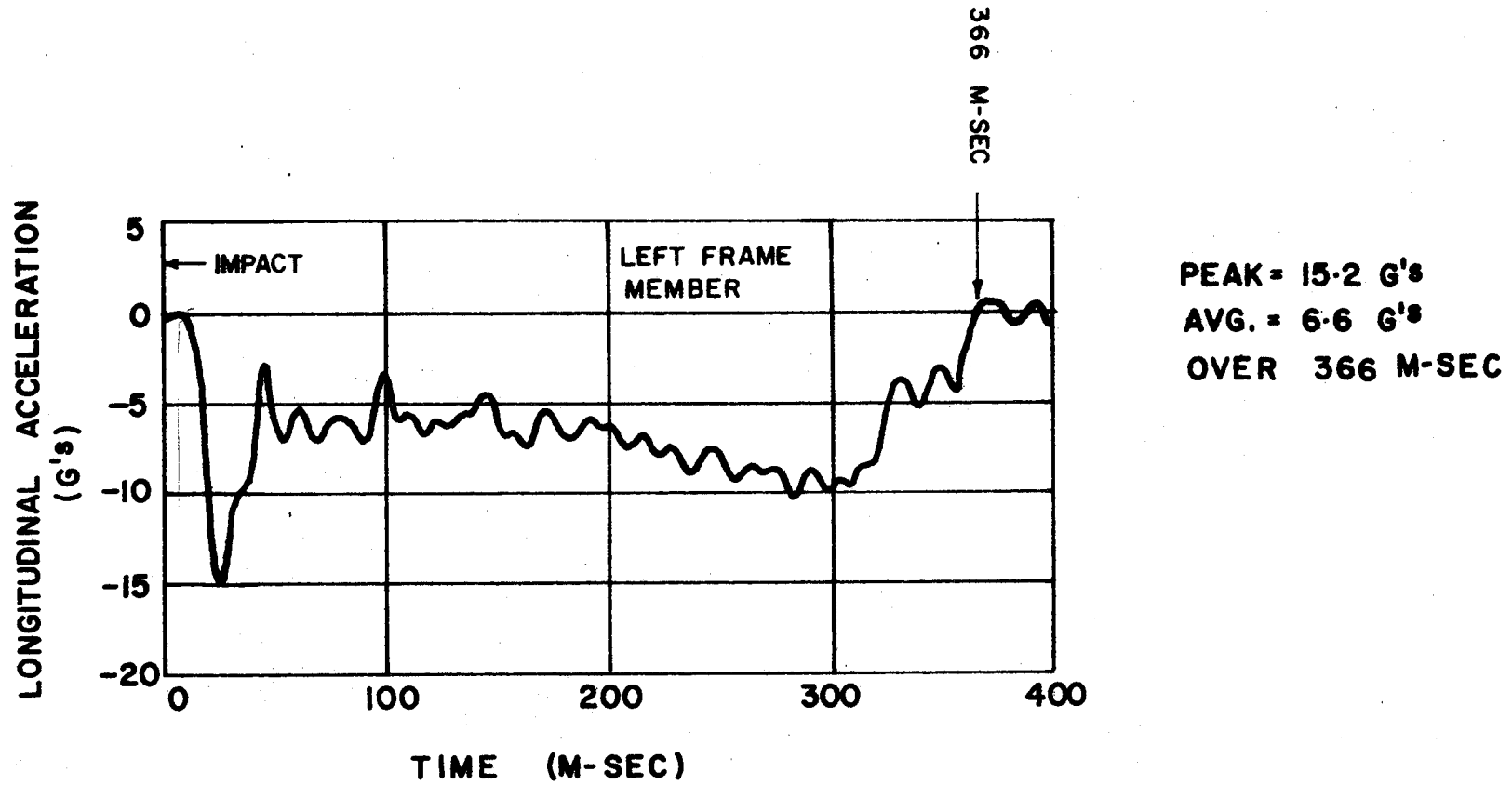

FIGURE 12 - LONGITUDINAL ACCELEROMETER DATA TEST 146 PC-1

TABLE 2
TABLE OF EVENTS

<u>EVENT</u>	<u>TIME(sec)</u>
Impact	0
1st row crushed; 2nd beginning.	.025
2nd row crushed; 3rd beginning; 2nd row squeezed downward between rows 1 and 3.	.039
4th row beginning to crush; 2nd and 3rd rows squeezed downward.	.069
Three rows nearest "wall" beginning to move in downward direction.	.096
Three rows nearest wall touching ground; dummy hits steering wheel.	.130
Truck begins moving noticeably.	.162
Crash Cushion Trailer begins to move noticeably forward, section nearest wall still in contact with ground. All barrels crushed. Front wheels of car almost off ground.	.211
Front wheels of car and wheels of Crash Cushion Trailer off ground.	.229
Dummy begins to move backward.	.261
All steel drums now moving as unit.	.275
Rear of car hits ground; front of vehicle and Crash Cushion Trailer up in air.	.312
Vehicle and Crash Cushion Trailer reach maximum height.	.615
Dummy leaning all the way back.	.757
Rear of vehicle hits ground second time.	.878
Dummy thrown forward again, probably hits steering wheel.	1.121
Maximum forward movement.	1.856
Vehicle comes to complete stop.	2.469

and plastic deformation of the vehicle which is as predicted by analysis.

Correlation of Theory and Test Data

The theory based on conservation of momentum and kinetic energy described earlier produced results which are in excellent agreement with the test data when the test values are used. That is, from the conservation of momentum and substituting values from Table 1 into equation No. 1 we get

$$V = \frac{4060}{4060 + 2010 + 9315} 92.8 = 24.5 \text{ fps.}$$

Now the vehicle kinetic energy just prior to impact

$$\text{K.E.}_{\text{before impact}} = \frac{4060 (92.8)^2}{64.4} = 542,920 \text{ ft-lb}$$

and after plastic impact the remaining kinetic energy is

$$\text{K.E.}_{\text{after impact}} = \frac{15,385 (24.5)^2}{64.4} = 143,280 \text{ ft-lb}$$

or energy lost during plastic impact = 399,640 ft-lb. The number of barrels required were

$$\frac{399640}{13500} = 29.60.$$

Each barrel is two feet in diameter and the available crush distance available for each barrel is 75 percent of the diameter (1). Then for three rows of barrels the crush distance is

$$\frac{29.60 \times 2 \times 0.75}{3} = 14.8 \text{ ft.}$$

The truck will travel after impact a distance

$$d = \frac{143,280}{9315 \times 0.7} = 22.0 \text{ ft.}$$

The maximum forward motion of the vehicle is 36.8 feet and the average deceleration for the event is 3.64 g's. (These values are compared with the data in Table 1. They vary less than 5% from the test data.) By using the relationship $\Delta V/\Delta t$ for the time of the main event (366 msec) the average deceleration is 5.8 g's. The relationship

$$\frac{V_i^2 - V_f^2}{2gs}$$

produces values which are high (8.4 g's) for the average deceleration to the end of the first significant peak. (Integration of the accelerometer trace gives 6.6 g's). This discrepancy is largely accounted for by noting that the value for s equals the crush distance of the crash cushion would be accurate only when the front of the barrier were totally stationary. Whereas, during the later part of the deformation period the barrels were crushing and moving forward simultaneously so that with an impacting speed of 92.8 fps then the distance required to slow the vehicle to 24.5 fps would be 18.8 feet rather than the 14.8 feet calculated as the crush distance of the portable crash cushion. From Table 2 we note that at time 0.211 sec the "crash cushion trailer begins to move noticeably forward,..." and at time 0.275 sec "all steel drums now moving as a unit." That is to say that during the 0.064 sec of this

time period the crash cushion trailer is both moving and crushing.

SUMMARY AND CONCLUSIONS

The crash cushion trailer is a workable easily used solution for protection against certain classes of accidents on our nation's highways and streets. The accidents would be the ones most likely to occur during maintenance operations where head-on or near head-on collisions would be likely to occur. Simple equations of mechanics are extremely accurate for the design and use of the crash cushion trailer. Further, the curve presented in Figure 2 can be used for the design of specific crash cushion trailers and the curves in Figure 3 will assist in the safe location of the crash cushion. The average deceleration predicted by the usual equations of mechanics will be very conservative, up to 25% high, and if used should be used with discretion.

The structural connections between the crash cushion trailer and the truck or other stabilizing vehicle should be adequate or even over-designed (see the appendix for a recommended design). The back up plate, also, should be stiff enough so that as uniform restraining force as possible will be applied to the barrels during an accident.

The crash cushion trailer can be used in three basic maintenance or construction operations. The first would be to protect both workers and errant motorists during and after working hours in detour situations where a missed detour would cause injury to errant vehicle occupants or workers or where combined damage to the errant vehicle and barrier would be less than what would be predicted to the construction as

machinery beyond the detour sign. In this situation the crash cushion trailer with its towing vehicle could be anchored on a temporary basis for the duration of the hazard and then moved to a new location as maintenance or construction progressed.

Another possible use would be as a temporary stationary crash cushion to be used to protect workers doing routine maintenance on driving lanes or shoulders. A few operations might be mowing, guardrail repair, chug-hole repair, or even collecting trash along heavily traveled highways. A driver could stay in the truck and move along with the task.

A third type of operation would be a moving operation in which the progress of the operation would proceed at a much slower speed than the traffic was moving. Such an operation might be striping of traffic lanes, placing traffic buttons or similar tasks.

It is significant to note that a crash cushion trailer for municipal streets could be much smaller than one used on high speed expressways. The distance a crash cushion trailer is placed from or follows an obstacle or worker to be protected should be governed by calculations for a safe distance or from Figure 3. An adequate margin of safety should be used for the final distance.

REFERENCES

1. White, Monroe Carlton and Hirsch, Teddy James, HIGHWAY CRASH CUSHIONS a special report, Texas Transportation Institute, November 1971.
2. Tamanini, F. J. and Viner, John G., "Energy Absorbing Roadside Crash Barriers," Civil Engineering, January 1970, pp. 63-67.
3. TEST AND EVALUATION OF VEHICLE ARRESTING, ENERGY ABSORBING, AND IMPACT ATTENUATION SYSTEMS, Texas Transportation Institute, November 30, 1971.
4. Nordlin, Eric F., Woodstrom, James H. and Doty, Robert N., DYNAMIC TESTS OF AN ENERGY ABSORBING BARRIER EMPLOYING STEEL DRUMS, California Division of Highways, January 1971.
5. Hirsch, T. J. and Ivey, Don L., VEHICLE IMPACT ATTENUATION BY MODULAR CRASH CUSHION, Texas Transportation Institute, June 1969.
6. Hanover, Joe G., letter to TTI Director, May 24, 1972.
7. White, Monroe C., Ivey, Don L., and Hirsch, T. J., IN-SERVICE EXPERIENCE ON INSTALLATIONS OF MODULAR CRASH CUSHIONS, Texas Transportation Institute, December 1969.
8. Hays, Gordon G., Ivey Don L., and Hirsch, T. J., FLEXBEAM REDIRECTIONAL SYSTEM FOR THE MODULAR CRASH CUSHION, Texas Transportation Institute, October 1970.

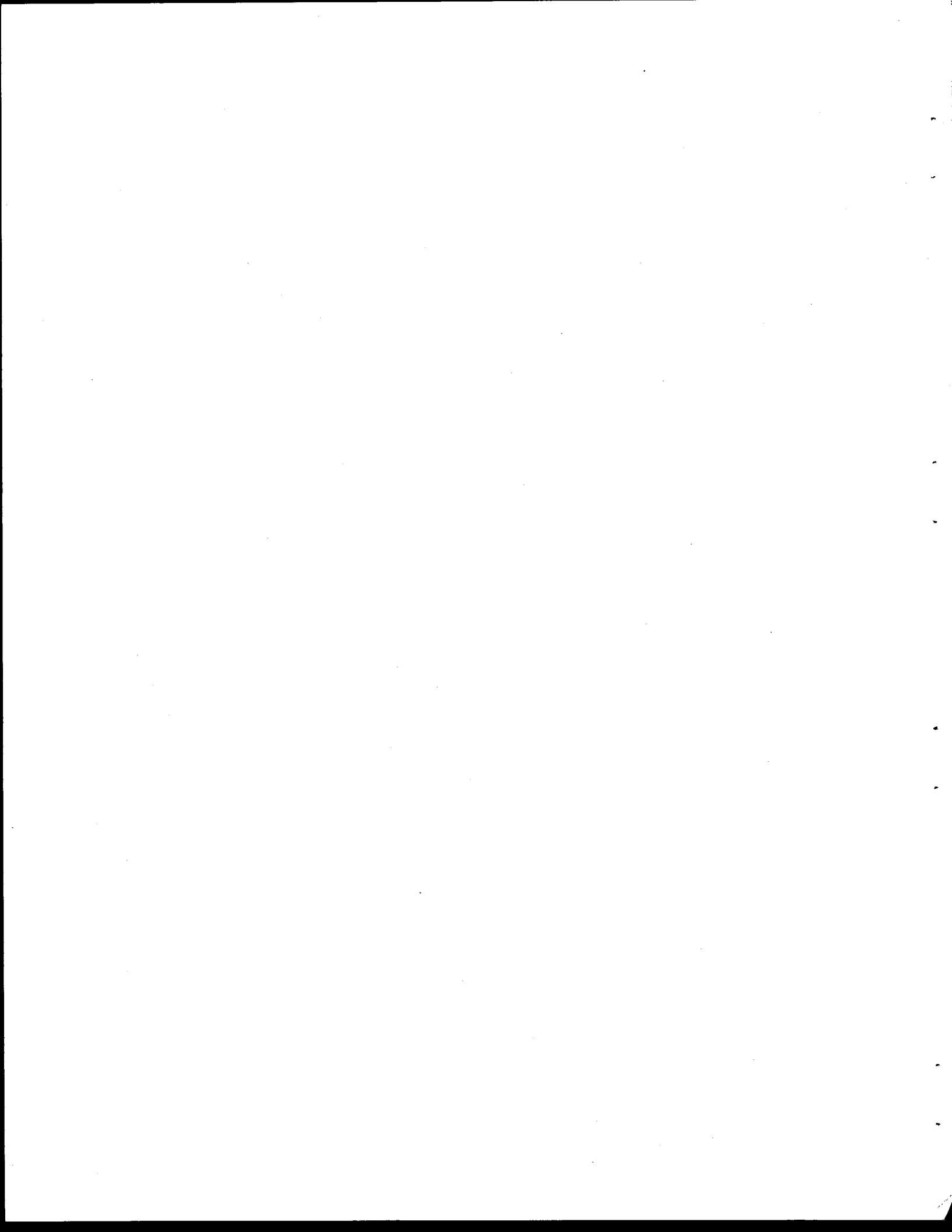

APPENDIX

DESIGN AND CONSTRUCTION OF A CRASH CUSHION TRAILER

The number of steel drums used in a crash cushion trailer can be determined by procedures outlined in the main body of the report. After this number has been determined a suitable arrangement must be decided on. A crash cushion too wide will intrude into adjacent driving lanes; and it will produce deceleration rates which are excessive. A crash cushion trailer too long will become unwieldy and will not adequately protect the towing vehicle or other obstacle. Generally a configuration of three wide will be a reasonable choice when passenger vehicles at usual highway speeds are being used as design criteria. The barrels will normally be arranged in a rectangular configuration except that a "soft nose" concept may be used for the rear two or three barrels. Figure A-1 shows a typical rectangular layout of a crash cushion trailer using 30 barrels. Figures A-2 and A-3 show additional details for a crash cushion trailer to be attached to a series of vehicles currently in use by the Texas Highway Department.

NOTE: The actual dimensions of the towing vehicle should be used to determine the various lengths and cuts of members.

Figure A-4 shows the minor required modifications to the truck to be able to successfully tow and stabilize the barrier.

There are several features which a designer should be aware of so that the assumptions used to determine the attenuation characteristics will not be violated. The first is that the back up plate should be stiff so that the various structural components attached to the plate

and truck are salvageable. This will save a considerable amount of effort in replacing the steel drums should a barrier be crushed. A 3/8 inch thick plate is sufficient for a three barrel wide crash cushion provided the edges are stiffened as shown in Figure A-1. Next, no more than four full rows of steel drums should be cantilevered over the trailer wheels, otherwise the tops and bottoms of the barrels tend to buckle under the dynamic loads imposed by high speed towing. However enough of the barrels must overhang in order to allow the nose to completely crush before coming in contact with the tires.

The side arms of the design shown are hinged at the barrier plate so that they may be readily connected or disconnected. A tongue jack is a practical necessity since the weight of the front end of the trailer is well in excess of what two men could be expected to lift.

Most states will require stop lights and direction lights. These may be attached to a plywood sheet (1/2 in) on the rear of the trailer or directly to the steel drums. Appendages as required or desired may be attached to the unit provided they do not materially change the crush characteristics of the system. Generally the preferred location for these attachments would be at the front of the trailer such as the warning sign support shown in Figure A-1. Objects such as flashing lights which are somewhat massive and could penetrate a windshield should be placed toward the front of the trailer where they will receive a smaller amount of impact energy.

These above details assume new 55 gallon drums specifically designed and manufactured for impact attenuation. However, used 55 gallon steel

A-3

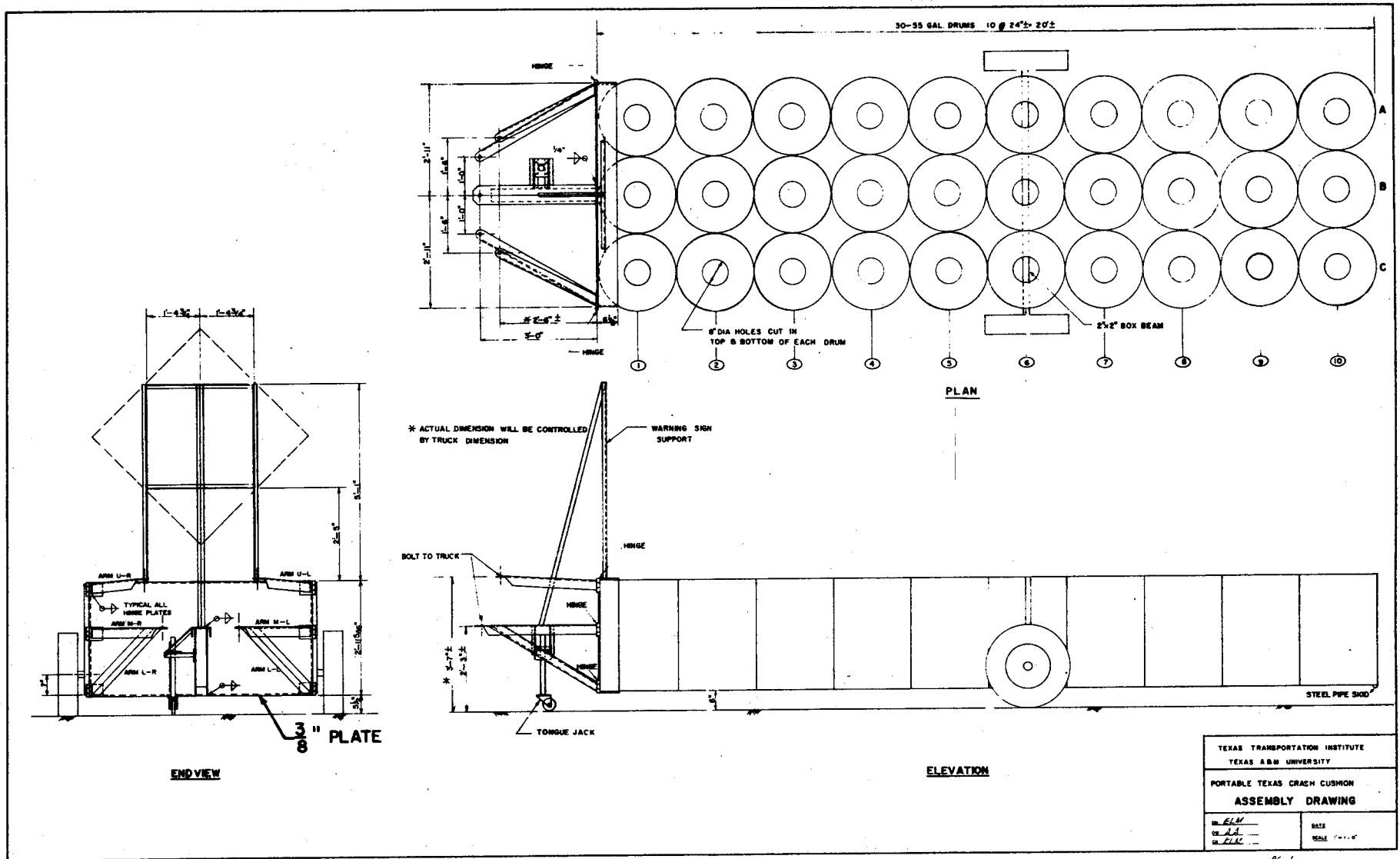

FIGURE A-1 - RECOMMENDED CRASH CUSHION TRAILER ASSEMBLY

A-4

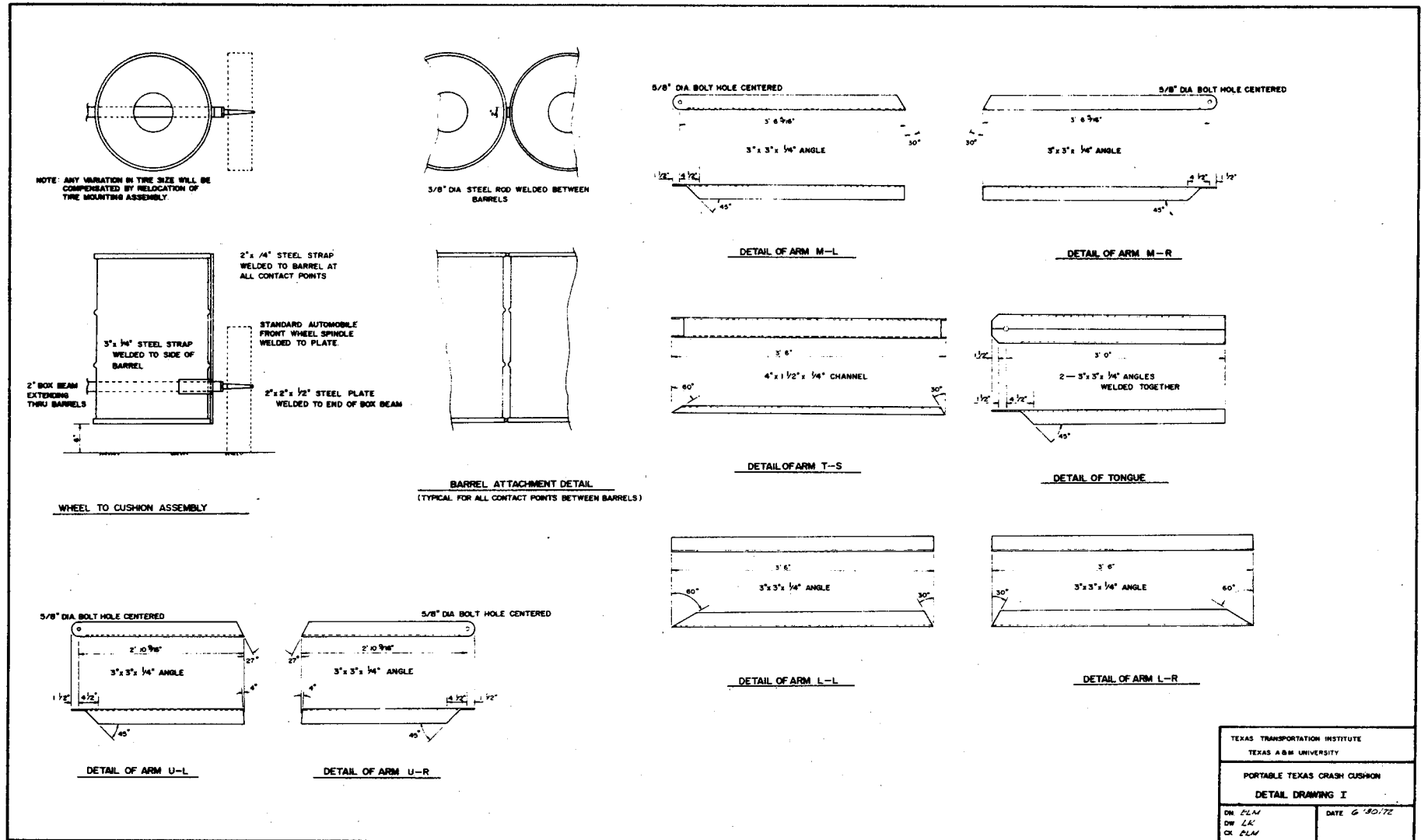
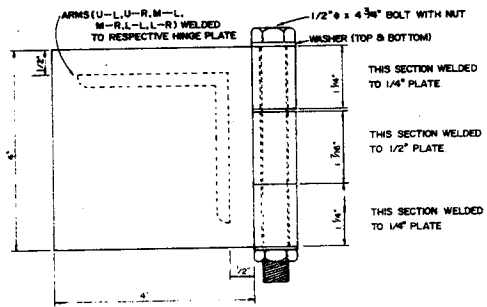
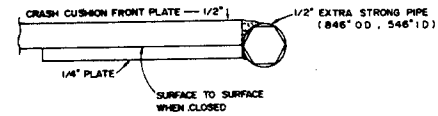
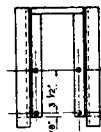

FIGURE A-2 - RECOMMENDED CRASH CUSHION TRAILER DETAILS I

A-5



DETAIL OF HINGE ASSEMBLY



NOTE THIS BRACKET IS CONSTRUCTED OF 1" ANGLE

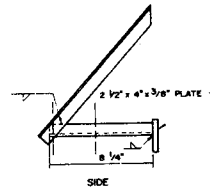
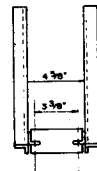

TONGUE JACK ASSEMBLY

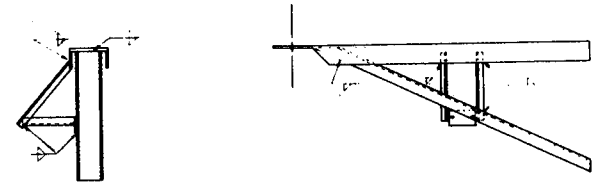

ASSEMBLY OF TONGUE, TONGUE SUPPORT, & TONGUE JACK

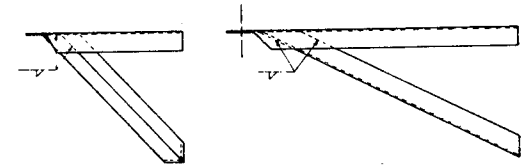

ASSEMBLY OF ARMS L-L, L-R, M-L, M-R
(THIS VIEW ILLUSTRATES ASSEMBLY OF ARMS M-L & L-L.
ARMS M-R & L-R ARE ON OPPOSITE SIDE OF TRAILER)

NOTE: ALL JOINTS & INTERSECTIONS TO BE WELDED ALL AROUND WITH FILLET WELDS. WELD SIZE TO BE EQUAL TO MINIMUM THICKNESS OF METAL AT JOINT.

TEXAS TRANSPORTATION INSTITUTE TEXAS A&M UNIVERSITY	
PORTABLE TEXAS TEST CRASH CUSHION DETAIL DRAWING II	
DN -CLM DW -LAC CK -CLM	DATE 6/30/72

PC 3

FIGURE A-3 - RECOMMENDED CRASH CUSHION TRAILER DETAILS II

WELD 4 LUGS ON PLATES AS SHOWN
(SEE DETAIL FOR LUG)

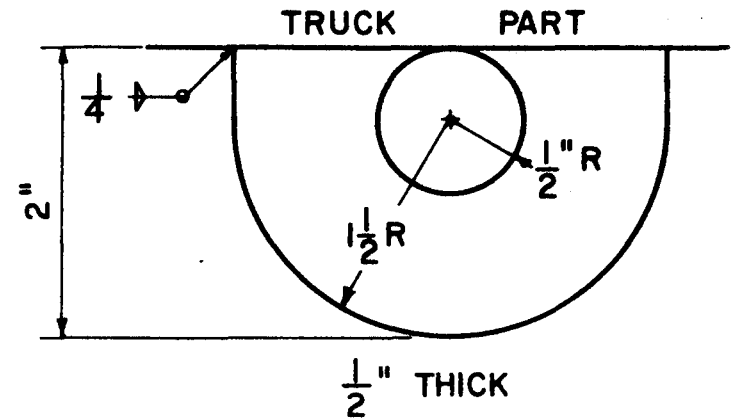
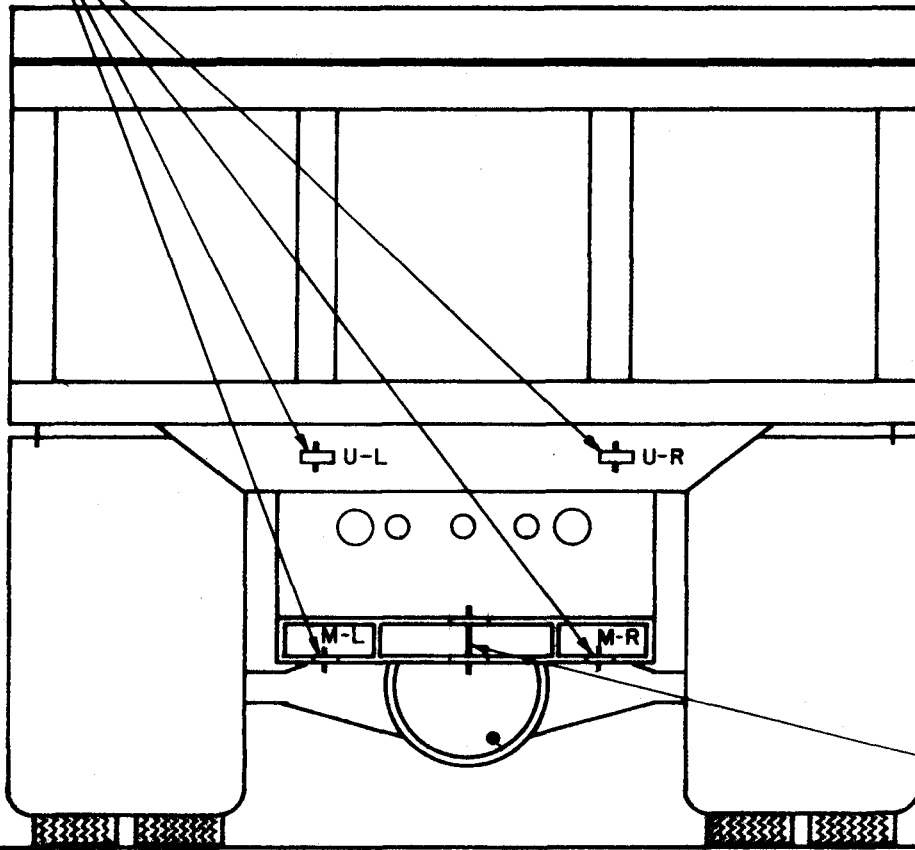

DETAIL OF LUG

BOLT TRAILER HITCH

TYPICAL THD DUMP TRUCK (NEWER MODEL)

FIGURE A-4 - RECOMMENDED CONNECTIONS TO TRUCK

drums such as empty paint containers may be used. Administrative circular No. 130-70 dated November 9, 1970 by the Texas Highway Department (White, M. C., CRUSH TESTS ON USED PAINT DRUMS, Texas Transportation Institute, a technical memorandum) outlines procedures for modifying certain of these drums so that they will have the same crush characteristics as the "standard" used in the analysis. A crash cushion trailer made of paint drums modified according to the recommendations of the above report and designed as described herein will produce a completely adequate unit. The use of these old drums is encouraged.

