

1. Report No. FHWA/TX-97/1454-1F		2. Government Accession No.		3. Recipient's Catalog No.	
4. Title and Subtitle ACCELERATED CONSTRUCTION METHODOLOGY FOR CONCRETE PAVEMENTS AT URBAN INTERSECTIONS				5. Report Date November 1996	
				6. Performing Organization Code	
7. Author(s) Serhan Secmen, James Schwarz, Stuart Anderson, and Dan Zollinger				8. Performing Organization Report No. Research Report 1454-1F	
9. Performing Organization Name and Address Texas Transportation Institute The Texas A&M University System College Station, Texas 77843-3135				10. Work Unit No. (TRAIS)	
				11. Contract or Grant No. Study No. 0-1454	
12. Sponsoring Agency Name and Address Texas Department of Transportation Research and Technology Transfer Office P. O. Box 5080 Austin, Texas 78763-5080				13. Type of Report and Period Covered Final: September 1994 - August 1996	
				14. Sponsoring Agency Code	
15. Supplementary Notes Research performed in cooperation with the Texas Department of Transportation and the U.S. Department of Transportation, Federal Highway Administration. Research Study Title: 72 Hour Urban Highway Intersection Replacement					
16. Abstract  Accelerated intersection reconstruction requires that all phases of the construction process be well-planned and included in the list of activities that must be completed prerequisite to reopening the intersection to the traveling public. Consequently, accelerated intersection - reconstruction includes an integrated effort to forge a team consisting of design, construction, and construction management expertise that can uniquely coordinate all construction-related activities in a timely and efficient manner. Concrete mixtures can be "qualified" relative to their capability to meet curing requirements stipulated by the construction schedule for the anticipated weather conditions at the time of construction. Proper planning and execution in the design stages will help minimize change orders during construction due to changes in the traffic phasing scheme and the impact of the construction upon the traveling public. Guidelines are provided to facilitate the overall planning and execution process.					
17. Key Words Concrete Hardening, Concrete Maturity, Accelerated Construction, Fast-Track Paving, Partnering, Accelerated Curing, Construction Guidelines			18. Distribution Statement No restrictions. This document is available to the public through NTIS: National Technical Information Service 5285 Port Royal Road Springfield, Virginia 22161		
19. Security Classif.(of this report) Unclassified		20. Security Classif.(of this page) Unclassified		21. No. of Pages 204	22. Price



**ACCELERATED CONSTRUCTION METHODOLOGY  
FOR  
CONCRETE PAVEMENTS AT URBAN INTERSECTIONS**

By

Serhan Secmen

James Schwarz

Stuart Anderson

Dan Zollinger

Research Report 1454-1F

Research Study Number 0-1454

Research Study Title: 72 Hour Urban Highway Intersection Replacement

Sponsored by the

Texas Department of Transportation

In Cooperation with

U.S. Department of Transportation

Federal Highway Administration

November 1996

TEXAS TRANSPORTATION INSTITUTE

The Texas A&M University System

College Station, TX 77843-3135





## **IMPLEMENTATION RECOMMENDATIONS**

The construction guidelines provided in this report will assist in the process of organizing, planning, and executing accelerated reconstruction of concrete pavement intersections.

This project explored four phases of the reconstruction process relative to planning, design, contractor interfacing, and construction. Each of these are key elements to the overall success of an accelerated construction effort. The guidelines provided in the appendix of this report are formatted to insure that the appropriate levels of effort are exercised in a timely and efficient manner. Following the guidelines will provide a step-by-step process to aid in achieving and meeting the opening requirements within the prescribed time frame.



## **DISCLAIMER**

The contents of this report reflect the views of the authors who are responsible for the facts and accuracy of the information presented herein. The contents do not necessarily reflect the official views or policies of the Federal Highway Administration or the Texas Department of Transportation. This report does not constitute a standard, specification, or regulation, nor is it intended for construction , bidding, or permit purposes.

## **ACKNOWLEDGEMENT**

Research findings presented in this report are a result of project efforts carried out at the Texas Transportation Institute, Texas A&M University, and Prairie View A&M University. The authors would like to thank the staff of the Texas Department of Transportation and the Houston District for their support throughout this study as well as the U.S. Department of Transportation, Federal Highway Administration.

# TABLE OF CONTENTS

LIST OF FIGURES .....	xiii
LIST OF TABLES.....	xiv
SUMMARY.....	xv
INTRODUCTION.....	1
BACKGROUND .....	1
RESEARCH OBJECTIVES.....	2
Construction.....	2
Materials .....	2
RESEARCH PROCESS .....	3
REPORT ORGANIZATION .....	5
CONSTRUCTION AND MATERIAL CONCEPTS FOR ACCELERATED INTERSECTION RECONSTRUCTION.....	7
INTRODUCTION .....	7
CONSTRUCTION MANAGEMENT TECHNIQUES .....	7
Schedule Reduction .....	7
Constructability.....	8
Design/Construction Integration.....	10
Team Building .....	10
Partnering.....	11
Contracting Methods .....	12
Incentive/Disincentive Contracts .....	12
Lane Rental.....	13
CONSTRUCTION METHODS.....	14
Demolition Methods .....	14
Concrete Placement .....	16
MATERIALS MANAGEMENT .....	17
Concrete Maturity: Definition and Purpose .....	17
Strength-Maturity Relationships.....	19

Curing .....	22
Methods of Curing .....	23
Hot-Weather Curing.....	24
PROCESS MODEL FRAMEWORK .....	24
DEVELOPMENT OF PLANNING AND DESIGN COMPONENTS.....	27
INTRODUCTION .....	27
West Columbia .....	28
Downtown .....	29
Outside the Downtown.....	29
CR 1301 and SH 36 Intersection.....	30
Red Bluff/Beltway 8 Intersection.....	31
Construction Phasing and Sequencing.....	31
Construction Method.....	32
Construction Schedule .....	32
Cost Estimate.....	33
CONCLUSION.....	33
DEVELOPMENT OF CONCRETE MATERIALS QUALIFICATION PROCESS.....	35
INTRODUCTION .....	35
DEVELOPMENT/EVALUATION OF LABORATORY STRENGTH RESULTS .....	37
Procedure for Laboratory Tests .....	38
Results .....	39
Evaluation of Strength-Maturity Relationship .....	40
Strength-Maturity Relationship .....	41
Regression Analysis and Results.....	41
DETERMINING LIMITING STRENGTH.....	43
Regression Method .....	43
Reciprocal Method.....	43
60 °F Chamber .....	45
85 °F Chamber .....	46

DEMONSTRATION OF TEMPERATURE INDEPENDENT STRENGTH	
MATURITY RELATIONSHIP .....	49
CONCLUSION.....	54
DEVELOPMENT OF CONTRACTOR INTERACTION AND CONSTRUCTION	
COMPONENTS .....	55
INTRODUCTION .....	55
CONSTRUCTION CONCEPTS.....	56
ALTERNATE CONSTRUCTION METHODS.....	56
PROPOSED INSTRUCTION METHOD.....	59
Revised Construction Method .....	59
ACTUAL CONSTRUCTION METHOD.....	60
Pre-Construction Planning.....	60
Schedule.....	61
Manpower .....	63
GENERAL COMPARISONS .....	63
CONCRETE STRENGTH QUALIFICATION.....	64
Field Work .....	65
Calibration of the Strength-Maturity Relationship.....	67
CONCRETE MATURITY-TIME SIMULATION .....	73
Opening Time Prediction.....	76
Validation.....	77
CONCLUSIONS.....	80
PROCESS MODEL FORMALIZATION.....	81
INTRODUCTION .....	81
MODELING APPROACH.....	81
72 Hour Intersection Reconstruction Process Model.....	84
72 HOUR INTERSECTION RECONSTRUCTION PROCESS GUIDELINES.....	88
CONCLUSIONS AND RECOMMENDATIONS.....	91
CONCLUSIONS.....	91
Planning and Methods .....	91

Intersection Reconstruction Implementation.....	92
RECOMMENDATIONS.....	93
REFERENCES .....	95
APPENDIX A: WEST COLUMBIA PROJECT .....	97
APPENDIX B: RED BLUFF/BELTWAY 8 PROJECT .....	113
APPENDIX C: TIME, TEMPERATURE, AND MATURITY DATA FOR LABORATORY TESTS .....	133
APPENDIX D: STATISTICAL ANALYSIS OF LABORATORY DATA.....	137
APPENDIX E: CHASEWOOD PARK DRIVE (SH 249) .....	141
APPENDIX F: TIME TEMPERATURE, AND MATURITY DATA AT THE FIELD.....	155
APPENDIX G: STATISTICAL ANALYSIS OF FIELD DATA .....	161
APPENDIX H: CONCRETE TEMPERATURE SIMULATION.....	165
APPENDIX I: 72 HOUR URBAN HIGHWAY INTERSECTION RECONSTRUCTION GUIDELINES.....	169



## LIST OF FIGURES

Figure 1. Flowchart of Research Process.....	3
Figure 2. Guillotine Breaker.....	15
Figure 3. Process Model Framework for 72 Hour Intersection Reconstruction.....	25
Figure 4. Reciprocal Method.....	45
Figure 5. Reciprocal Method for Specimens Cured at 60 °F.....	46
Figure 6. Reciprocal Method for Specimens Cured at 85 °F.....	47
Figure 7. Modified Reciprocal Method for Specimens Cured at 85 °F.....	48
Figure 8. Strength-Maturity Relationship for 60 °F Specimens.....	51
Figure 9. Strength-Maturity Relationship for 85 °F Specimens.....	52
Figure 10. Strength-Maturity Relationship for all Specimens.....	53
Figure 11. Time-Cost Analysis Results.....	58
Figure 12. Site Layout.....	65
Figure 13. Placement of Thermocouples.....	66
Figure 14. Model 5 versus Test Results.....	69
Figure 15. Strength-Maturity Relationship for Field Conditions.....	70
Figure 16. One Beam Method.....	73
Figure 17. Maturity, Strength, Time Relationship for Field Conditions.....	76
Figure 18. Comparison of the Model to March 16, 1996 Data.....	78
Figure 19. Comparison of the Model to March 17, 1996 Data.....	78
Figure 20. Cell Modeling Technique.....	82
Figure 21. IDEF0 Model Structure.....	83
Figure 22. Context Diagram for 72 Hours Intersection Reconstruction Process.....	85
Figure 23. First Decomposition of Context Diagram.....	86

## LIST OF TABLES

Table 1.	Comparison of Concrete Placement Techniques .....	16
Table 2.	Mixture Proportions .....	38
Table 3.	Test Results for 60 °F Chamber Specimens .....	40
Table 4.	Test Results for 85 °F Chamber Specimens .....	40
Table 5.	Results of Regression Analysis of Different Models.....	42
Table 6.	Calculations for 60 °F Data.....	50
Table 7.	Calculations for 85 °F Data.....	51
Table 8.	Intersection Reconstruction Alternatives .....	57
Table 9.	Field Data .....	67
Table 10.	Strength and Maturity of Field Cured Beams .....	68
Table 11.	Regression Results for Field Strength Data .....	68
Table 12.	Calculations for Field Data.....	69
Table 13.	Comparison of the Field and Laboratory Results .....	70
Table 14.	Opening Maturity Calculations .....	71
Table 15.	Opening Maturity Calculations for the 3rd Placement .....	72
Table 16.	Comparison.....	77
Table 17.	Comparison of IDEF0 and Guidelines Terminology.....	89

## SUMMARY

This research effort demonstrated that concrete pavement intersection and segments of concrete pavement intersection can be effectively reconstructed and opened in a 72 hour period. One of the primary objectives of this research project was to identify, develop, and refine techniques for accelerating urban highway intersection reconstruction. This required the formulation of a process model framework in which to guide the direction of the research effort and the application of different construction knowledge and expertise are integrated into the planning and design phases of a project.

The process framework consists of four components: planning, design, contractor interaction, and construction. The planning component is used to determine if a particular intersection can be a candidate for 72 hour reconstruction. The design component is used to confirm that the intersection can be completed within a 72 hour period or less, if possible. Confirmation is achieved by estimating the amount of time to complete various phases of the construction work to include the time of concrete curing and hardening. This is facilitated by the use of a computerized heat of hydration model. This model predicts the maturity and the temperature history of the concrete with time during the hardening process of the concrete, as a function of the concrete material properties and the weather conditions at the time of construction. The design phase is also used to develop design documents to address bidding requirements. The contractor interaction component addressed construction methodology and efficiency towards project accomplishment within the allotted time schedule. This component also addresses contingency planning to cover unexpected events that may delay or stop the work progress. Also, the mix design must be qualified to insure that the concrete will meet opening and strength requirements. Finally, during construction, production rates are monitored and proper quality assurance and quality control is performed. The maturity of concrete is measured so that opening time can be predicted.

The process framework was formulated into a set of guidelines to facilitate implementation by the Department and by the contracting agency. Both detailed steps and information required for each component were developed through the application of different construction, materials, and traffic control techniques on three demonstration projects. Through process modeling, specific steps, inputs, outputs, constraints, and resources necessary to perform each step are described.



## **INTRODUCTION**

### **BACKGROUND**

Due to the highly developed Texas highway system, very little construction is occurring on highways on new alignment. Instead, the majority of the construction efforts are focused on rebuilding existing facilities which have either reached the end of their design life, have inadequate lane capacity, or have debilitated due to excessive use. The reconstruction of an existing facility poses a number of challenges to transportation agencies, contractors, and motorists. The close proximity of vehicles, work areas, and workers greatly increases the potential for hazardous conditions. This is particularly true in urban work zones where the number of vehicles, traffic signals, intersections, and driveways is higher than that of non-urban areas. The situation is further compounded by the fact that reconstruction of existing facilities typically extends over a longer period of time due to the need to accommodate traffic flow during construction activities.

One of the difficulties of conducting urban highway intersection reconstruction is working under heavy traffic flows. In order to reduce the impact of construction on traffic congestion, intersection replacement must be done in a rapid and efficient manner. This type of construction is often referred to as “fast-track” construction because of the accelerated pace associated with it. Fast-track construction, as previously noted and as it applies to highways, is a special type of construction where construction methods and activities are planned to minimize the construction duration and the impact on the traveling public.

Any design, construction, or traffic control alternative that would reduce exposure to the potentially hazardous conditions in urban highway intersection reconstruction projects could be beneficial. One such alternative would be to accelerate the reconstruction of intersections on urban highways. The reconstruction of an urban intersection is a challenging task because traffic flow must be maintained over the duration of the project. However, if the reconstruction of these intersections could be completed in a short period of time, such as 72 hours, then it may be possible to close the

intersection during the accelerated reconstruction. A key factor in the development of the traffic control plan is the amount of time the intersection will be closed to traffic. The shorter the closure, the more feasible the traffic control plan.

Closure of all or part of an urban intersection allows a contractor complete access to the pavement section within the work zone and eliminates conflicts with vehicles. The elimination of traffic flow also minimizes the need for complex traffic control set-up and removal. If the concept of intensive work in a short period of time could be applied to urban intersections, the result may be a decrease in overall travel delay and a reduction in conflicts between construction activities and traffic flow. The decision on whether to utilize accelerated reconstruction of urban intersections is a function of many different factors such as: traffic volumes, site conditions, materials costs, construction phasing, impact on local businesses, and others. Research was performed to identify, assess, and quantify the various factors that could impact the decision to accelerate urban intersection reconstruction. A set of guidelines for performing this type of reconstruction were also developed for implementation by TxDOT.

## **RESEARCH OBJECTIVES**

### **Construction**

The primary objective of the research project was to identify, develop, and refine techniques for expediting urban highway intersection reconstruction. These techniques were to be developed to minimize traffic delays and accident potential, and minimize total construction time. The research focused primarily on intersections reconstructed using continuously reinforced concrete pavement.

### **Materials**

Use of concrete pavements at major intersections has become increasingly popular in recent years. However, it takes a certain amount of time for the concrete to harden and reach minimum strength requirement. The time period required for hardening and

strength gain of concrete, also referred to as the curing phase of concrete, depends on several factors such as mixture proportions, chemical admixtures, and curing temperature conditions. Since the duration of the hardening period of concrete is largely undefined at the time of placement, the scheduling of cure time for the concrete is not a trivial matter.

In order to plan and organize an accelerated or “fast-track” construction project, the construction schedule needs to be established prior to the beginning of the work. Therefore, an estimation of the duration of curing and concrete hardening needs to be made by the contractor. Therefore, one of the objectives of this study is to consider one aspect of this scheduling process relative to concrete hardening to develop a method that can be used to predict the time of curing and strength development of concrete under field conditions.

## RESEARCH PROCESS

In order to fully develop a methodology for 72 hour intersection reconstruction, a defined research process was established. This process provided the research team with fixed goals and a pathway in the completion of the project. Figure 1 depicts a flowchart of the research process.

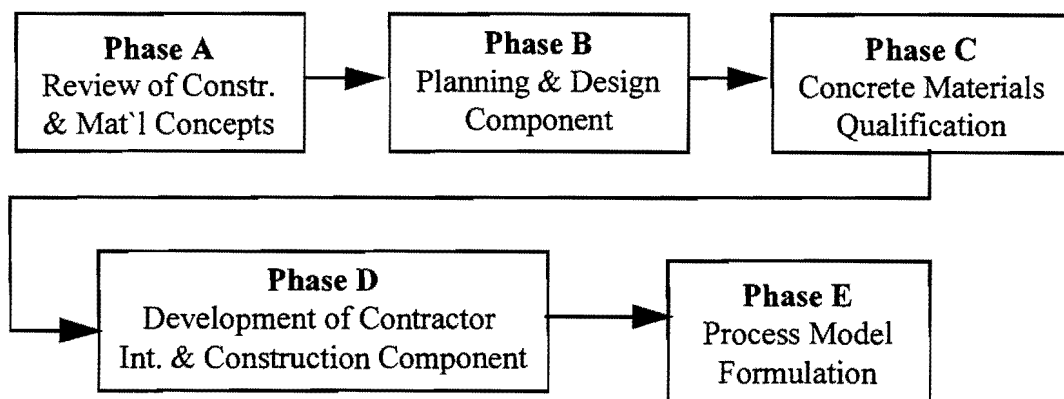

**Figure 1. Flowchart of Research Process**

The research process was composed of five major phases:

Phase A - Review of Construction and Materials Concepts

Phase A involved collecting relevant information with respect to different aspects of expediting urban intersection construction and qualifying concrete slab applications. Issues such as constructability and design/construction integration were analyzed so as to determine their benefit to expediting intersection reconstruction. Literature reviews focused on concepts related to the project. Personal interviews with TxDOT personnel, as well as outside construction expertise, were also completed as a part of this phase. Finally, a process modelling framework for 72 hour intersection reconstruction is presented as a basis for developing detailed process guidelines.

Phase B - Planning and Design Component

The main objective of this research phase was to develop the framework for the planning and design components of 72 hour urban intersection reconstruction. Two projects were selected. One project was in the programming phase and the other was in the design phase of project development. Once demonstration projects were identified, the application of the concepts reviewed in Phase A were applied to each of these projects in relation to accelerated intersection reconstruction. Each project posed different issues with respect to the development and refinement of key construction management, construction methods, and traffic control techniques.

Phase C - Concrete Materials Qualification

The objective of this research phase was to develop methods and tools that are used for the qualification of concrete applications relative to its compressive strength. Laboratory tests were performed to develop a non-destructive testing method for the qualification of concrete mixtures. The applicability of this method in the field was examined through various tests. Results of this phase of the study were incorporated into the intersection reconstruction process guidelines.

Phase D - Development of Contractor Interaction and Construction Component

A third demonstration project was used as a basis for developing Phase D. This was accomplished in March of 1996 when the material and construction management concepts developed during the research process were used to assist in the reconstruction



of the Chasewood Park Drive and SH 249 intersection in Houston, Texas. Knowledge gained through this demonstration project was used to develop details of the intersection reconstruction process framework for contractor interaction and construction.

#### Phase E - Process Model Formulation

Upon the completion and the analysis of all subsequent phases, the next phase formalizes the 72 hour intersection reconstruction process model. This model identified every step the research team accomplished during the entire study. The model evaluates an intersection from conception during project programming through completion of construction.

The final step in the development of the process model was to develop a set of guidelines for design and construction engineers to follow when implementing the 72 hour intersection reconstruction process for an intersection. The guidelines furnish the engineers with a defined set of steps and information needed to successfully implement the concepts developed throughout the research effort.

### **REPORT ORGANIZATION**

The following details the organization of the construction approach for 72 hour urban highway intersection replacement. The report is divided into seven chapters: introduction; construction and material concepts for accelerated intersection reconstruction; development of planning and design components; development of concrete materials qualification process; development of contractor interaction and construction components; process model formalization; and conclusions and recommendations.



# **CONSTRUCTION AND MATERIAL CONCEPTS FOR ACCELERATED INTERSECTION RECONSTRUCTION**

## **INTRODUCTION**

The first step in the research process was to review concepts in several subject areas that pertain to facilitating the 72 hour intersection reconstruction process. The goal of this review was to identify techniques that could benefit the reconstruction process as well as define how these techniques apply to the process. The research team identified a number of construction management techniques for possible utilization in the 72 hour intersection reconstruction process. These techniques included: schedule reduction, constructability, design / construction integration, team building, partnering, and contracting methods. As well as identifying construction management techniques, the research team consulted with construction expertises to identify construction methods that might also apply to the intersection reconstruction process.

## **CONSTRUCTION MANAGEMENT TECHNIQUES**

### **Schedule Reduction**

Schedule reduction was a key technique needed for a successful 72 hour reconstruction process. This technique is required primarily due to the short project duration, and therefore the need to save as much scheduling time as possible. Research by the Construction Industry Institute (CII) discussed five different techniques for schedule reduction (1). These techniques were: freeze the project scope, constructability, concurrent engineering, cycle time analysis, and the use of electronic media. Of these five techniques only two, constructability and concurrent engineering, were found to have applicability to the 72 hour intersection reconstruction process.

Constructability, as defined in the CII, is the optimum use of construction knowledge and experience in planning, design, procurement, and field operations to achieve overall project objectives. This particular topic is discussed in more detail in the

next section. Concurrent engineering is merely executing tasks in parallel instead of in series. Although the CII research described this process more in terms of design, the concept could be applied to the construction process, particularly the scheduling of construction operations.

A critical point made by the CII pertained to the difference between schedule reduction and schedule compression. Schedule reduction was defined as the use of techniques that shorten a project duration and do not result in an increase in project cost. Schedule compression, on the other hand, shortens a project duration, but it increases project cost. Although, ideally, the goal of the 72 hour intersection reconstruction process was to reduce the schedule, a schedule compression was unavoidable due to the weekend work, night work, and extra cost of admixtures in the concrete. The goal of the process was then refined to try to minimize the additional cost of reconstructing an intersection using the process developed.

### **Constructability**

Constructability is a technique that was of key importance to the development of the 72 hour intersection reconstruction process. As discussed, constructability was one of the two schedule reduction techniques on which the research team placed major significance. Constructability can optimize the following project elements: overall project plan; planning and design; construction-driven schedule; costs and estimates; and construction and major construction methods. A number of factors require consideration to achieve these goals. These include, but are not limited to, the following (2):

- Managing the project,
- Contracting strategy including contract clauses,
- Risk management,
- Labor requirements,
- Access to site: size of construction equipment, weather restraints; and urban restrictions,

- Site layout,
- Access to remove and replace pavement material,
- Sequence of construction,
- Availability of construction equipment and materials,
- Prefabrication,
- Pre-assembly,
- Construction management organization plan,
- Quality management,
- Materials management, and
- Safety.

The above list of constructability factors would be too difficult to implement without a set plan for execution. In order to implement constructability in the 72 hour intersection reconstruction process, total constructability management was studied. Total Constructability Management (TCM), according to Anderson, Fisher, and Gupta, is a framework to integrate constructability and quality into various phases of project development-planning, design, construction, and maintenance/operation (3). TCM helps remove the traditional barriers between design and construction teams by increasing lateral flow of information and ideas. Under total constructability management, construction teams become involved in communication and coordination with planning and design and procurement teams. The research team believes that the implementation of both constructability and total constructability management would enable TxDOT to determine if an intersection could realistically be reconstructed under the design constraints. By determining this early in the project life, TxDOT would avoid unnecessary work on intersections that are not suited for the 72 hour process. Further, constructability analysis would ensure that designs are constructible for those intersections that are candidates for 72 hour reconstruction.

## **Design / Construction Integration**

Perhaps the most important development concept addressed throughout the research process was the integration of design and construction. Currently, there is limited implementation of construction concepts throughout the design process by TxDOT. However, by using construction techniques such as constructability during planning and design, TxDOT can save both themselves and contractors numerous problems related to both time and money. Anderson and Fisher have developed a constructibility review process through the National Cooperative Highway Research Program that is a tool for integrating construction knowledge into the planning and design phases of a project (4, 5).

The construction issues that should be addressed during design deal with constructability and the phasing, scheduling, and estimating of construction. These minimal tasks allow TxDOT to address construction related problems early in the project life. Any problems identified during the design phase can be addressed and, therefore, eliminate troubles later in the project.

The majority of the construction related problems identified during the design phase are associated with design details. Some design details make it difficult for contractors to construct projects under the time and budget constraints set forth in the plans and specifications. However, if these details can be changed or eliminated in the preliminary stages of design, then the contractor can more easily build the intersection and, therefore, save both time and money for TxDOT. In most cases, a simple change in the project scope will allow for the majority of problems to be ameliorated. These issues played important roles in the development of the 72 hour reconstruction process and guidelines.

## **Team Building**

Team building, as defined by the CII, is a project-focused process that brings together key stakeholders of a project's outcome. These stakeholders are usually

representatives from the owner, designer, and/or contractor (6). Team building seeks to resolve differences, remove roadblocks, and build and develop trust and commitment among team members. Also, team building focuses on a common mission statement, shared goals, interdependence, accountability, and problem solving skills of team members.

By utilizing team building throughout the 72 hour reconstruction process, TxDOT could minimize the risks associated with this fast-track style of construction. This would be accomplished by bringing construction expertise early in the project life and therefore eliminating construction related design problems that otherwise might not have been noticed until the construction process began.

According to the CII publication, team building could also reduce adversarial relationships, lower project costs, improve project quality, and shorten project schedules. These again are a result of utilizing construction expertise early in the project life. With these goals in mind, the research team felt that implementing team building concepts into the 72 hour intersection reconstruction process would be essential in producing a quality reconstruction process.

### **Partnering**

Partnering is similar to team building. Partnering in the public sector is performed on a project-by-project basis. Typically, a state agency begins the partnering process with a contractor after the contract is awarded. The basic goal of partnering is to create an atmosphere that is conducive to enhancing communication, minimizing disputes, attaining mutually beneficial goals, and sharing risk. Both agency and contractor personnel participate in the process.

Several aspects of partnering that are possibly viewed as negative are difficulties encountered between state agency / contractor relationships when the low bidder wins the contract. This problem is currently being addressed by Iowa DOT through their initiation of new partnering concepts in concert with Iowa contracting authorities and associations (7).

Other departments such as the Arizona DOT are currently implementing partnering into their projects. Their projects are regularly finished under budget, ahead of schedule, and with very few filed claims. Ohio DOT also has documented that partnering has enhanced an existing positive atmosphere of cooperation between themselves and contractors (8).

TxDOT currently utilizes partnering in many projects. This partnering scheme is usually implemented once a contractor has been awarded a project. This form of partnering could be utilized by the 72 hour process, therefore, enabling TxDOT to use methods they have already developed and tested.

### **Contracting Methods**

In order to ensure the successful reconstruction of an intersection, the research team felt that specific contracting methods required study. These methods included Incentive/Disincentive (I/D) and Lane Rental contracts, as well as the planning that went along with them.

#### *Incentive/Disincentive Contracts*

According to Jaraiedi et al in “Incentive/Disincentive Guidelines for Highway Construction Contracts,” the use of I/D provisions in contracts is applicable to projects that need to be completed in the shortest possible time (9). Jaraiedi further stated that projects that utilized I/D contracts, in many cases, were completed up to 50 percent faster, and were of higher quality than normal projects. Jaraiedi attributed this increase in schedule reduction and quality to the amount of planning an I/D contract requires.

The following is an excerpt from a list of points that Jaraiedi recommended be considered in the preparation and execution of I/D contracts.

- Extra time and effort must be given to project development so as to avoid costly field changes once the project begins. Pre-design field reviews are



important at this stage as the actual construction at the site may be different from that indicated on old construction plans.

- It is important that the contract clearly specifies the procedures that will be in place should any changes in the scope of work take place. Additionally, the contract should state under what circumstances the I/D completion date will be extended and under what circumstances the contractor is responsible for delays.
- All parties that will be involved with the construction, including local officials and police, should participate in pre-construction meetings. This will help uncover any unusual features of the project, as well as any restrictions that may affect the construction such as a restriction on jack-hammering at night due to noise problems.
- Prior to awarding the contract, there should be a written agreement between the contracting agency and utility companies addressing what work needs to be done and when it will be done. This should minimize delays once the construction begins and reduce the potential for conflicts between the contracting agency and the contractor.
- Prior to construction, arrangements for the moving of right-of-ways must be confirmed and completed. Failure to do this could result in a lengthy delay in the construction process.

These points brought up by Jaraiedi provided the research team with vital information on the level of planning that this style of reconstruction needed. Although the ultimate decision on the contract style lies with TxDOT, the procedures pertaining to the front-end planning of I/D contracts was useful.

### *Lane Rental*

Incentive / Disincentive was not the only contracting method studied for application with the 72 hour reconstruction process. The research team also reviewed lane rental as a possible contract type to aid the process. Lane rental as described by

Herbsman et al in “Time is Money: Innovative Contracting Methods in Highway Construction,” is where the contractor is charged a fixed sum for the closure time during reconstruction (10). To use the lane rental method, TxDOT would require all bidding contractors to submit their cost estimate of the work to be performed as well as the time needed for lane closures related to reconstruction. The total cost of the project would then be the sum of the work estimate plus the cost of all essential lane closures. This method would require TxDOT to calculate the user costs of all effected lane closures. Herbsman describes this process in detail in “Time is Money.”

The major advantages with the lane rental contract method is that it allows the contractor to choose the best work patterns for construction. This method also motivates a contractor to reduce the construction time or pay out lane rental fees for delays. Although these advantages are in favor of TxDOT, lane rental contracts, in some cases, lead to poor quality and disputes over unavoidable construction delays, such as poor weather. It was for these reasons that the research team felt that the lane rental style of contract would not work well with the 72 hour reconstruction process. Although the team decided not to try to implement the lane rental contract, the issues Herbsman addressed were considered for development of the guidelines.

## **CONSTRUCTION METHODS**

Once the research team had identified the construction management techniques that would benefit the 72 hour intersection reconstruction process most, the focus then turned to identifying highly productive construction methods. Two main construction areas were studied: the demolition of existing materials and the placement of concrete. It was in these two operations the research team felt the most time could be saved.

### **Demolition Methods**

The demolition and removal of existing materials is probably the most time consuming of all operations that take place during an intersection reconstruction. This

activity requires the removal of concrete, asphalt concrete, soil, or any other materials the intersection contains. Intersection demolition requires the contractor to break the existing materials into moveable pieces and haul these pieces off site. Two main methods of breaking materials were identified as the most productive: utilizing a guillotine breaker, and pre-cutting slabs for later removal.



**Figure 2. Guillotine Breaker**

A guillotine breaker, shown in Figure 2, is a machine that drops an iron block continuously on the pavement as it moves through the intersection. This breaker turns about a four wide path of the intersection into small removable pieces. Once the breaker is finished breaking the concrete, the small pieces can then be removed using an ordinary excavator. This method is extremely efficient at demolishing concrete, but less efficient

at asphalt concrete. One major problem with utilizing this breaker is the possibility of damaging underground utilities through the continuous pounding put out on the concrete.

Pre-cutting an intersection into removable slabs is another method the research team found would be beneficial to the reconstruction process. This method entails pre-cutting the intersection into slabs 4' by 4' prior to the start of reconstruction. Once the intersection is closed, the slabs are then lifted out and hauled off site. Although this type of demolition and removal is effective and time saving, it can also be very expensive.

### **Concrete Placement**

Although there are numerous methods available for placing concrete, three main methods were focused on for the 72 hour intersection reconstruction process: Vibrating/Air Screeds, Bidwell Screeds, and Slipforming. Each method for placing concrete had both advantages and disadvantages to the 72 hour process. These three methods for placement could reach production rates dependent only on the amount of concrete available. In other words, every machine researched could go as fast as the contractor could get the concrete to it. However, each machine had different requirements for space and labor necessary. Table 1 shows the comparison of the three methods for placing concrete.

**Table 1. Comparison of Concrete Placement Techniques**

<b>Method</b>	<b>Labor Needed</b>	<b>Space Needed</b>	<b>Applicability to Process</b>	<b>Cost</b>
Vibrating / Air	High	Low	High	Low
Bidwell	Low	Medium	Medium	Med/High
Slip forming	Low	High	Low	High

The vibrating screed method for placing concrete is probably the best suited for the 72 hour reconstruction process. This is primarily because it is the most common

method used by contractors in urban highway applications. The vibrating screed requires minimal extra space because it rides on top of the formwork. This method, however, uses more labor than both the bidwell screed and slipformer. The extra labor is due to the fact that the vibrating screed does not have a mechanized means for spreading the concrete. The bidwell screed and slipformer are both highly automated machines that require minimal labor to operate. Both machines spread and finish the concrete with a process that merely needs operators. The major problem with these two methods is that they require expensive pieces of equipment. Since all three methods can produce the same production rate, then it stands to reason that the least expensive of the methods, the vibrating/air screed, be the suggested method for the reconstruction process.

Two methods for delivering the concrete were analyzed for possible use in the 72 hour intersection reconstruction process: pumping and direct pouring. These two methods are commonly used for the delivery of concrete. Pumping is predominantly used only when concrete can not be directly poured. This occurs when no direct access to the pour section is available for the mix truck. Poor soil conditions or immovable obstructions are the most common conditions when pumping is employed. Both methods for delivering concrete proved to be necessary for the reconstruction of most intersections. The method for delivering the concrete is dependent on each intersection, and therefore no distinct method can be specified in the 72 hour process.

## **MATERIALS MANAGEMENT**

### **Concrete Maturity: Definition and Purpose**

Concrete hardens and gains strength as chemical reactions take place. The chemical reactions associated with concrete hardening are exothermic reactions. As a consequence of these exothermic chemical reactions, the heat generated from the cement reacting with water increase the temperature of concrete.

As these chemical reactions takes place and concrete hardens, the strength of concrete increases. This strength development or gain continues at slower and slower

rates until it becomes asymptotic to a limiting level of strength which is a function of curing conditions. This limiting level of strength for concrete is the highest strength value that the concrete can reach.

Maturity is a parameter that has been used by several engineers to relate the combined effect of time and temperature to strength development of concrete. Various mathematical models of strength-maturity relationships have been proposed since the maturity concept was first introduced by McIntosh (11) 1949. Saul (12) defined maturity as an integral of time and temperature above the datum temperature. Saul explained that the concrete hardening occurs above a certain temperature which he referred to as the datum temperature. Datum temperature is the minimum temperature that the strength development could occur. Hence, only the temperatures above the datum temperature should be taken into account while calculating maturity.

Maturity functions represent the relationship between the actual temperature history of the concrete and the strength of the concrete. In 1949, McIntosh (11) studied the maturity functions for accelerated curing conditions and developed procedures to predict the strength development of concrete during the curing phase. He proposed the product of time and concrete temperature above a datum temperature that could be used to summarize the temperature history.

After McIntosh, Nurse (13) defined relative strength as the ratio of actual strength to limiting strength, and he showed that relative strength development can be expressed as a function of the product of time and temperature. Unlike McIntosh, Saul used the curing chamber temperatures instead of actual concrete temperatures while calculating the maturity values. However, unlike McIntosh, he did not propose the use of a datum temperature.

Summarizing McIntosh's and Nurse's studies, Saul suggested that the calculation of the combined parameter be done above datum temperature. Saul proposed a mathematical expression of maturity as follows:

$$M = \sum_{t=0}^t (T - T_o) \Delta t \quad (1)$$

where,

- M = maturity of the concrete at time t,
- $\Delta t$  = time interval of the hardening process,
- T = average temperature of the concrete during the time interval t, and
- $T_0$  = datum temperature.

This equation is known as the Nurse-Saul function. Saul (12) suggested that the datum temperature should be  $-10.5^\circ \text{C}$ . In 1956 Plowman (14) suggested a value of  $-12^\circ \text{C}$  for datum temperature. Also Bergstrom (15) suggested that the temperature of the concrete be counted from a datum value of  $-10^\circ \text{C}$ . Although datum temperature depends on the cement material properties, the  $-10^\circ \text{C}$  is the most widely accepted value for datum temperature.

In 1977, Freisleben Hansen and Pedersen (16) suggested maturity should be related to chemical characteristics of cement, such as activation energy. Activation energy is the threshold level of energy required for the chemical reaction to take place.

$$M_a = \sum_{t=0}^t k \Delta t = A \sum_{t=0}^t e^{\left(-\frac{E}{RT}\right)} \Delta t \quad (2)$$

where,

- k = rate constant (1/s for a first-order reaction),
- A = frequency factor constant (1/s for a first-order reaction),
- E = activation energy (J/mol),
- T = absolute temperature ( $^\circ\text{K}$ ), and
- R = gas constant, (J/mol  $^\circ\text{K}$ ).

Later, Carino (17) suggested that both functions can be used to calculate maturity. He mentioned that the activation energy should be calculated if the equation that is proposed by Freisleben Hansen and Pedersen is to be used.

### **Strength-Maturity Relationships**

Maturity is expressed as a function of time and temperature or time, temperature, and activation energy. However, the relationship between strength and maturity is not

defined with maturity functions. Maturity functions, as discussed earlier, only present a mathematical relationship that represent the combined effect of time and temperature. Several mathematical models have been discussed over time to explain the relationship between strength and maturity.

In 1956, Nykanen (18) proposed an exponential relationship between strength and maturity according to the Nurse-Saul equation:

$$S = S_{\infty}(1 - e^{-kM}) \quad (3)$$

where,

S = compressive strength,  
 $S_{\infty}$  = limiting compressive strength,  
M = maturity, and  
k = a constant.

Nykanen suggested that the value of constant k would depend on the water-cement ratio and the type of cement.

The same year, Plowman (14) observed that when strength was plotted as a function of logarithm of maturity (based on the Nurse-Saul function) the data fell very close to a line. Therefore, he suggested that there might be a logarithmic relationship between strength and maturity.

$$S = a + b \log(M) \quad (4)$$

Where parameters 'a' and 'b' depend on the water-cement ratio and the cement type. However, this relationship predicts an ever-increasing strength which is practically not true.

In 1971, Kee (19) proposed a hyperbolic function to express the relationship between strength and maturity:

$$S = \frac{M}{\frac{1}{A} + \frac{M}{S_{\infty}}} \quad (5)$$

This equation is more reasonable when compared with Equation 4, since it does not predict ever-increasing strength. However, this relationship does not take the influence of temperature into account in the early stages of curing which is very important for long-



term strength of concrete. Also, according to this relationship the strength development should start right after the placement of concrete and follow an asymptotical pattern to its limiting strength. However, the strength development starts after the final setting of the concrete.

Later, Carino (20) proposed a mathematical derivation for the equation representing the strength-maturity relation. He suggested that for an isothermally-cured concrete, the rate of increase of its relative strength (ratio of actual strength to its limiting strength) is proportional to the fraction or the square of fraction of remaining strength. Then he produced another parameter to account for the dormant period of cement hydration. This idea is first suggested by McIntosh, where he referred to this parameter as “offset” maturity. Carino proposed a strength-maturity relation as follows:

$$S = S_{\infty} \frac{K(M - M_o)}{1 + K(M - M_o)} \quad (6)$$

where,

- $S_{\infty}$  = limiting strength of concrete at infinite maturity,
- $M$  = maturity of concrete, expressed by any of the proposed maturity functions,
- $M_o$  = offset maturity, and
- $K$  = a constant.

According to this relationship, the strength development occurs after the maturity value reaches to  $M_o$ .

In 1978, Lew and Reichard (21) proposed another strength-maturity relationship. This equation was an improvement of Plowman’s equation (Equation 4). They proposed a logarithmic function based on their experimental studies:

$$S = \frac{S_{\infty}}{1 + D(\log(M - 16.7))^b} \quad (7)$$

where,

- $S_{\infty}$  = limiting strength of concrete at infinite maturity,
- $M$  = maturity of concrete, and
- $D, b$  = constant parameters.

In 1985, Freisleben Hansen and Pedersen (22) suggested that the relationship between strength and maturity should be similar to the relationship between heat of hydration and maturity. They proposed an exponential relationship:

$$S = S_{\infty} e^{-\left(\frac{\tau}{M}\right)^a} \quad (8)$$

where,

$S_{\infty}$  = limiting strength,  
 $M$  = maturity,  
 $\tau$  = characteristic time constant, and  
 $a$  = shape parameter.

Equation 8 is the most recently proposed strength-maturity relationship. The strength-maturity relationships give similar results at early maturities. The simplicity of the expression is as important as the accuracy of the relationship.

All the strength-maturity relationships, except the one proposed by Plowman, are accurate and meaningful. The relationship proposed by Plowman (Equation 4) predicts ever increasing strength. The strength-maturity relationship proposed by Freisleben Hansen and Pedersen (Equation 8) is very accurate and simple. It can be rewritten to simplify the relationship between maturity and strength and can be predicted by simple linear regression analysis. This relationship will be explained in detail in the “Evaluation of Strength-Maturity Relationship” section.

## **Curing**

The aim of curing is to ensure as much hydration as possible. Self-desiccation which prevents further hydration can occur in pastes with lower w/c ratios, unless water is supplied externally. In theory, there is enough water in concrete to ensure complete hydration if the w/c ratio is 0.42 or greater. However, in practice, water is lost from the paste by evaporation, or by absorption of water by aggregates, formwork, or the subgrade (23).

The rate of strength development is affected by the concrete temperature. Curing at low temperatures can result in a higher ultimate strength, in spite of the fact that the initial rate of strength development is lower.

### *Methods of Curing*

There are two main systems of maintaining a satisfactory moisture content:

1) *Water Curing*, where the continuous or frequent application of water through ponding, sprays, steam, or saturated cover materials such as burlap or cotton mats, rugs, earth, sand, sawdust, and straw or hay are used. Keeping the concrete moist by means of a fine spray is an efficient method when water is plentiful and runoff is no problem. (23)

The use of coverings that can hold quantities of water in addition to preventing evaporation is another means of water curing. Coverings of this type require periodic moistening, since they tend to dry out, so regular supervision is required. (24)

2) *Sealing*, where the prevention of excessive loss of water from the concrete by means of materials such as sheets of reinforced paper or plastic, or by the application of a membrane-forming curing compound to the freshly placed concrete. (23) Their convenience and lower labor requirements have led them to displace the more traditional water curing methods in many instances. Formwork can also act as an evaporation barrier, but wooden formwork will absorb moisture from the concrete if not kept damp during the curing period. (24)

Waterproofed paper or plastic sheeting should be applied as soon as the surface has hardened sufficiently to prevent surface damage and after the concrete has been thoroughly wetted. Plastic sheeting is more cumbersome in that it is more difficult to use and to maintain in place. Plastic films can be bonded to absorbent materials, which help to retain and redistribute moisture that evaporates from the concrete and condenses on the cover. In this way the moisture can be returned to the concrete and improve its curing. Both paper and plastic can be colored white to reflect sunlight and reduce absorption of heat in the summer, or can be colored black to increase absorption of heat in the winter or cool paving days. (24)

Membrane forming compounds are formulated from resins, waxes, or synthetic rubbers dissolved in a volatile solvent or emulsified in water. Upon removal of the solvent by evaporation, an almost impermeable membrane forms on the surface and seals the concrete against moisture loss. Pigments can be added to the formulation: a white pigment in hot weather to reduce absorption of heat, and gray or black for cold weather. The use of pigment is advisable so that one can tell whether a complete covering has been applied. A curing compound should not be used during construction of pavements in the fall which will be exposed to de-icing salts, since the membranes retard the air drying that is needed to improve the salt-scaling resistance of the surface. (24) Some contractors have a tendency to dilute the curing compound in order to facilitate placement via spraying.

#### *Hot-Weather Curing*

Providing proper temperature and moisture conditions for curing of concrete is much more critical and important in hot weather than under normal temperatures, since hot weather leads to more rapid drying of concrete. (23) Water curing, although not often used, should be continuous to avoid volume changes due to alternate wetting and drying. The need for adequate continuous curing is greatest during the first few days after placement of concrete in hot weather. During hot weather, provided favorable moisture conditions are continuously maintained, concrete may attain a high degree of maturity in a very short period of time. (23)

### **PROCESS MODEL FRAMEWORK**

The primary objective of the research project was to identify, develop, and refine techniques for expediting urban highway intersection reconstruction. To achieve this objective, a process model framework was conceptualized early in the research. This framework formed the basis for developing and applying different construction, materials, and traffic control techniques in accelerated intersection reconstruction. A

fundamental concept behind the framework is that the intersection reconstruction process must commence early in project development and continue throughout design and construction. This is only possible if construction knowledge and expertise is integrated into the planning and design stages of project development.

As delineated in Figure 3, the process framework has four main components. Planning screens the intersection to determine if the intersection is a candidate for 72 hour reconstruction. The design component confirms that the intersection can be completed within 72 hours, or preferably 60 hours. Further, this component develops design documents that contain sufficient information for contractors to effectively bid a 72 hour intersection construction project. The contractor interaction component of the framework is critical to planning the details of construction to ensure that the most efficient and cost effective construction effort is accomplished and completed with the contract time allowed. This component includes contingency planning to cover possible risks that may impact construction completion. Finally, during the construction component, construction operations are monitored to ensure that the intersection is opened as planned.

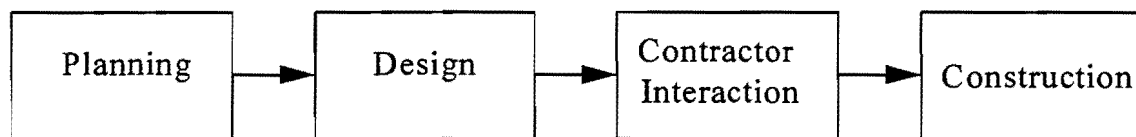

**Figure 3. Process Model Framework for 72 Hour Intersection Reconstruction**

Using this process framework as a guide, the research team developed detailed steps that describe each process component. Information required to perform each process step was also captured. Both the detailed steps and information required for each component were developed through the application of different construction, materials, and traffic control techniques on three demonstration projects. These three projects were in different stages of project development. Finally, to formalize the framework and its components, a process modeling technique was employed. This technique is a structured

and systematic approach that helped the research team describe the intersection reconstruction process in detail. Through process modeling, specific steps, inputs, outputs, constraints, and resources necessary to perform each step are identified. This formal process became the background for developing user-friendly guidelines. The next four chapters describe the development of the 72 hour intersection reconstruction process.

## **DEVELOPMENT OF PLANNING AND DESIGN COMPONENTS**

### **INTRODUCTION**

Several key concepts were considered important when developing the planning and design components of the process model framework for 72 hour intersection reconstruction. First, the process should commence early in the project life cycle and must be a focus area during design. This ensures that intersections not suitable for 72 hour reconstruction are eliminated early. Candidate intersections must be completed within 72 hours or, more realistically, within 60 hours. Achieving this requirement must be confirmed during design. Finally, design documents must reflect a design that can be constructed. Second, construction knowledge must be incorporated into the planning and design components. Third, the impact of traffic control must be assessed early to screen intersections where full or partial closure is not feasible. These three concepts are most appropriately addressed through the planning and design components of the process framework.

Two demonstration projects provided a vehicle to evaluate the application of these three key concepts. These projects assisted the research team in understanding how construction management techniques, construction methods, and traffic control procedures are applied in accelerated intersection reconstruction. Further, the first two demonstration projects provided a basis for developing specific steps in the model and identifying key information required to perform these steps. This latter assessment enabled the research team to develop details of the process model framework and then convert these details into usable guidelines.

The two demonstration projects analyzed were West Columbia and Red Bluff / Beltway 8. Each project posed different questions that helped the development of the first two components of the reconstruction process framework. These projects were, therefore, ideal for study purposes. Red Bluff was in the programming stage (planning) and West Columbia was in the design stage of project development.

The first demonstration project was a section of highway CR 1301 that passes through the city of West Columbia, Texas. This particular project not only included intersections, but also highway and driveway reconstruction. The second project was an intersection at Red Bluff / Beltway 8 in Houston, Texas. This intersection was the closest project to the original concept for an application of 72 hour intersection reconstruction process.

### **West Columbia**

The West Columbia demonstration project began in the formal design stage of a pending TxDOT project. The research team worked concurrently with an engineering firm located in Houston, Texas. In addition, the research team reviewed construction methods and sequences with a local highway contractor on an informal basis. Site visits were also made to better understand construction problems. This approach provided the research team with an opportunity to interact with both design engineers and construction experts during the preliminary phases of an actual project. This also allowed the research team to develop the design component of both the reconstruction process and guidelines.

The West Columbia project consisted of three separate sections titled: Downtown, Outside the Downtown, and CR 1301 / SH 36 Intersection. Although the original intent of the research project was to apply the construction and traffic control concepts to merely urban intersections, this particular project allowed the team to test these concepts with highway, intersection, and driveway construction. A number of issues including traffic control, drainage placement, significant profile changes, and construction methods were addressed with respect to each section of the project. In particular, construction methods focused on slipforming, use of bidwell screeds, and pumping concrete, all in the context of available space and traffic control requirements. In order to meet the design requirements, each separate section was addressed independently. One basic decision made early was that drainage construction needed to be completed prior to the start of any other construction. Appendix A contains the construction phasing plans for all three sections associated with the West Columbia project.



### *Downtown*

The downtown phasing plan for the West Columbia project is illustrated in Figures A-1 through A-3 in Appendix A. This section of CR 1301 required a separate phasing plan because its pavement width differed from that of “outside the downtown”. The downtown area in West Columbia contained a three lane highway with shoulders existing on both the north and south sides of the road. This extra space allowed for two-way traffic to be maintained on one side of the road while construction occurred on the other. By maintaining traffic flow completely on one side of CR 1301, only two primary phases of construction were needed. TxDOT procedures for traffic control dictated the traffic control plan.

The first primary phase of construction was planned for the north half of CR 1301. This phase began with the reconstruction of the north halves of the intersections of 14th and 17th streets with CR 1301. These two intersections were the boundaries of the length of the downtown area. It was then decided that while these intersections were being reconstructed, demolition and excavation would take place on the roadway between them. Once 14th and 17th streets were ready for traffic, reconstruction of the section of the roadway between them would follow. Three intersections lie between 14th and 17th street: 15th, Broad, and 16th. These intersections would be closed during the reconstruction of the roadway and poured straight through, with their tie-ins being performed after the main roadway was completed. The remaining driveways on the north half of the downtown area were the final work that would be completed during the first phase of the downtown construction. The second phase of the downtown area reconstruction was set up to mirror the first phase.

### *Outside the Downtown*

The “outside the downtown” area consisted of the roadway east of 14th street and west of 17th street. This section of roadway was primarily a two-lane road with shoulders of varying widths. Due to the length of this section of road, reconstruction could not possibly be completed within 72 hours. However, this section still needed to be

phased. Figure A-4 in Appendix A contains a sample of the phasing plan for outside the downtown area. This phasing plan utilizes the minimum width of the road so as to accommodate the entire section of CR 1301. Figure A-5 in Appendix A shows the cross-section of the phasing plan developed for the outside the downtown area. It was determined that this reconstruction be completed merely on an accelerated schedule.

### *CR 1301 and SH 36 Intersection*

The intersection between CR 1301 and SH 36 was the final sub-project in the West Columbia project. This intersection could not be fully closed and therefore, traffic flow in both directions had to be maintained. This posed a number of problems with phasing and sequencing the intersection. It was decided by the research team that if the intersection could not be completed in less than four construction phases, then normal intersection phasing (dividing the intersection into four sections, and reconstructing one quarter at a time) would be utilized for the intersection. However, after a number of attempts by the research team, a three phase plan for reconstructing the intersection was developed.

The phasing plan for the CR 1301 and SH 36 intersection is illustrated in Figures A-6 through A-8 in Appendix A. Although the intersection could not be completely closed to traffic, the south half of the intersection could be closed. This was accomplished by detouring the SH 36 northbound traffic on to SH 35. From SH 35, all traffic maneuvers could be accomplished. Further, all southbound SH 36 traffic was also detoured to SH 35, thus all traffic maneuvers for the CR 1301 and SH 36 intersection could be maintained regardless of the south half closure. Figure A-9 in Appendix A contains a city map of West Columbia outlining the proposed detour.

The final two phases of the intersection reconstruction consisted of splitting the remaining half of the intersection into two sections that would still allow all traffic maneuvers to take place. Phase 2 of the reconstruction (Figure A-7) involved rebuilding the northwest corner of the intersection. This phasing, however, created a sharp angle in the center of the intersection that could possibly hinder left turns onto SH 36 from

CR 1301 and right turns from SH 36 to CR 1301. This problem was alleviated by detouring affected traffic movements through the intersection and onto SH 35. From SH 35, all traffic movements could more easily be performed. Figure A-8 in Appendix A displays the final phase of the CR 1301 and SH 36 intersection.

### **Red Bluff / Beltway 8 Intersection**

The second demonstration project studied was the Red Bluff / Beltway 8 intersection in Houston, Texas. This intersection is shown in Figures B-1 and B-2 in Appendix B. The Red Bluff intersection was not part of any project currently underway by TxDOT. This intersection was presented to the research team with the instruction to determine whether or not the intersection could be reconstructed using the 72 hour process. This allowed the research team to develop the planning stage of the research process and guidelines. The Red Bluff intersection was a large intersection measuring approximately 5650 square yards. This intersection is typical of those intersections that lie under expressway overpasses. The intersection consisted of two one-way turnarounds and two, one-way frontage roads that intersected a four-lane, two-way road. Full closure of the intersection proved to be the only traffic control plan that would allow complete reconstruction of the intersection within the design constraints. The following sections will discuss the results developed for the Red Bluff intersection.

#### *Construction Phasing and Sequencing*

Phasing the Red Bluff intersection proved to be quite difficult due to the large size and number of intersecting roadways of the intersection. This intersection had a total of six intersecting roadways, unlike the Chasewood and West Columbia intersections which only had one roadway intersection. This greater number of intersecting roadways meant that the number of construction joints would be increased. As a result, phasing of adjacent construction joints had to be staggered, relative to time, to allow for concrete

curing times. The resulting construction phasing is illustrated in Figures B-3 through B-10 in Appendix B.

The first step in phasing the Red Bluff intersection was to divide the intersection into different pour sections. A total of sixteen different pour sections were needed in order to avoid placing adjacent construction joints. These sections ranged in size from 100 SY to 1240 SY. Table B-1 in Appendix B displays design data pertaining to the different pour sections. Each pour section is labeled beginning with A and ending with P. Figures B-3 through B-10 identify these phases.

Once the various pour phases were determined, the next step in the process was to begin sequencing the placement of these sections. The sequence of pours had to be carefully planned in order to avoid placing adjacent construction joints. The final sequence with crews for the construction of the Red Bluff intersection is displayed in Table B-2 in Appendix B.

### *Construction Method*

Although many different methods could have been employed to reconstruct the Red Bluff intersection, the research team decided to utilize the most common ones. Table B-3 shows the methods proposed for each phase of the reconstruction along with their respective estimated production rates. Due to the large size of the intersection, it was ascertained that two separate crews were necessary to reach the production rate needed to complete the intersection within 60 hours (see Table B-2). Only with two crews working simultaneously can the intersection be demolished, graded, formed, re-bared, and poured in time for a 60 hour project duration.

### *Construction Schedule*

The construction schedule for the reconstruction of the Red Bluff intersection is illustrated in Figure B-11. Utilizing the production rates determined from the construction methods in the previous section, durations for each phase of the project were

calculated. Table B-1 displays the size and duration of each pour section contained in the Red Bluff intersection. Once the durations for each section were determined, the construction sequence was utilized to schedule the reconstruction.

### *Cost Estimate*

The final step completed on the Red Bluff intersection was the cost estimate. It was necessary to compile an estimate in order to display the economic impact of the reconstruction. Table B-4 shows the estimate for the 72 hour reconstruction of the Red Bluff Intersection. As seen in the table, the total cost to TxDOT for the intersection reconstruction would be approximately \$ 309,600.

## **CONCLUSION**

Through the development of both the West Columbia and Red Bluff projects, the research team determined the steps that would be required during both the planning and design components of the process model framework. The planning component of the project required the formation of a design team and also the pre-evaluation of the intersection. Development of the West Columbia project highlighted the need for obtaining the right type of expertise. This expertise must include timely input of knowledgeable construction professionals. Traffic operations expertise is essential early because the ability to detour traffic away from the intersection is the key determinant as to whether or not the intersection is a candidate for accelerated construction. Red Bluff is an example where full closure can be achieved and, thus, provides an intersection that would pass an initial screening evaluation. If these inputs are assessed through a team approach, better decisions will result.

The design component of the project required the design team to develop preliminary design data, perform a constructability analysis, evaluate the intersection based on the constructability analysis and available design data, and to finalize the design documents for letting the project. West Columbia identified the need to have certain

project and design information available prior to performing a constructability analysis. Constructability analysis must focus on planning and sequencing, construction methods, and potential construction timing. Red Bluff emphasized the importance of construction scheduling techniques, cost analysis, and the application of historical information to develop an approach that can meet a 60 hour reconstruction schedule. Finally, incorporating specific construction related information into specifications and design documents provides a mechanism to convey the design intent to contractors who bid on an accelerated reconstruction project.

# **DEVELOPMENT OF CONCRETE MATERIALS**

## **QUALIFICATION PROCESS**

### **INTRODUCTION**

The time of curing for a newly placed concrete pavement extends until the minimum strength requirement is met. The capability to accurately predict the time of curing can be used as a valuable tool in construction scheduling, especially in fast-track construction. Typically, concrete strength testing is essential for accurately estimating the curing time. However, for standard testing and quality control procedures, destructive-type tests where the samples are broken under compressive or flexural load is not appropriate. The amount of time to prepare and manage several test specimens can sometimes present coordination difficulties for highway agencies. Therefore, non-destructive testing methods where a minimum of test specimens are involved should be considered to monitor the strength development of a concrete placement.

Concrete strength can be predicted non-destructively by measuring a quantitative material parameter relative to the behavior of concrete and relating this parameter to the strength of the concrete. This material parameter typically is related to the factors that affect the strength of concrete, such as concrete temperature and time of curing during strength gain.

Maturity, a parameter related to the temperature and time, can be used as a non-destructive testing parameter relative to concrete strength gain. Maturity is a parameter directly proportional to time and temperature of the concrete and can be calculated by measuring the temperature of concrete.

A mathematical model which correlates the strength of concrete to maturity is commonly used to estimate in-place strength of concrete. Maturity, that is calculated by measuring the temperature of concrete during hardening, can be used along with the mathematical relationship between concrete strength and maturity to estimate the concrete strength.

The strength-maturity relationship depends on the mixture proportions and concrete temperature during strength gain. In other words, the strength-maturity

relationship is unique for specific mixture proportions and curing conditions. A strength-maturity relationship developed under one certain condition can not be used for any other conditions.

If a temperature-independent model can be developed, then this model could be utilized at different curing conditions, as long as the same mixture proportions are used. Moreover, once a strength-maturity relationship is developed at the laboratory for a particular mixture design, this relationship can be utilized at the field where the curing conditions are different than that of the laboratory.

The temperature independent strength-maturity relationship can be utilized at the field to validate the strength of concrete by measuring the maturity at the field. Validating the concrete strength is very important for quality purposes. Usually, concrete strength is measured by casting field beams during the placement of concrete and testing these beams at some certain time intervals. However, by using this method, the opening time can not be predicted until the required strength limit is attained.

A series of laboratory tests was carried out as an example of how the strength-maturity relationship for a particular mixture proportion could be established. Various mathematical relationships between strength and maturity were also evaluated. Different curing conditions were used during the tests, so that the results could be used for the investigation of temperature effect on the strength-maturity relationship. Possible ways to implement this relationship in the field were investigated in order to monitor in-place concrete strength and accurately predict time of opening.

The approach of this research is to formulate a process to implement the maturity method in the field relative to a temperature independent strength-maturity relationship. If a temperature independent strength-maturity relationship could be developed under the laboratory conditions for a specific mixture design, then this relationship can be utilized in the field to evaluate the in-place concrete strength. The evaluation of a concrete mixture in terms of strength gain and time of curing can be used as a “qualification process.” Moreover, the opening time of the concrete application can be predicted by using the strength-maturity relationship.



A field study was carried out to evaluate the utility of a temperature-independent strength-maturity relationship model. The evaluation approach was based on laboratory strength test results as compared to strength results from the field. Statistical analysis was done to evaluate the comparability of the strength-maturity relationship.

## **DEVELOPMENT / EVALUATION OF LABORATORY STRENGTH RESULTS**

The purpose of this section is to present the procedures and results of the laboratory tests performed to evaluate the strength-maturity relationship. As mentioned earlier, several strength-maturity relationships have been proposed over time. A series of laboratory tests were performed. The results of these tests were statistically analyzed to find the mathematical form that represents the strength-maturity relationship best.

As explained earlier, the strength development depends on the curing conditions. The maturity-strength relationship can not be utilized at different curing conditions unless a temperature independent model is used. A temperature independent model needs to be incorporated in order to utilize the strength-maturity relationship under variable curing conditions as occurs in the field. Therefore, the effect of temperature on the strength-maturity relationship should be determined by conducting the laboratory tests at different curing conditions. However, as mentioned earlier, the strength development characteristics of the same mixture will change due to its early-age curing conditions.

Several strength-maturity equations were suggested as presented and discussed in the previous chapter. Also, it was mentioned that a series of laboratory tests should be carried out in order to establish the corresponding strength-maturity relationship for a given combination of concrete materials. Consequently, the strength-maturity relationship is unique for a given mixture design.

It was mentioned in the previous chapter that various strength-maturity models have been proposed, any of which will provide satisfactory results. As will be pointed out, the strength and maturity data obtained from laboratory tests can fit reasonably well with any of the models.

In order to demonstrate how a temperature independent strength-maturity model can be developed from laboratory test specimens, two different curing conditions were used during the laboratory tests in order to investigate the effect of temperature on concrete strength gain. Also, the laboratory test results will be used to evaluate different strength-maturity relationships.

The same mixture proportions and materials as the Chasewood Driveway Compaq Intersection (SH 249) reconstruction project were used for the laboratory tests. The proportions used for laboratory tests are shown in Table 2.

**Table 2. Mixture Proportions**

<b>Materials</b>	<b>Amount</b>	<b>Unit</b>
Cement (Type I)	665	lb.
Fine Aggregate	1255	lb.
Coarse Aggregate (Limestone)	1803	lb.
W/C Ratio	0.32	-
Paveair 90 (air entrainer)	3.3	oz.
Pozzolith 300 N (water reducer)	10	oz.
Reobilt 1000 (superplasticizer)	99.8	oz.

### **Procedure for Laboratory Tests**

Concrete test specimens were prepared and cured in environmental chambers at a constant temperature and humidity level until the time of testing. The environmental chambers were set at 60° F and 85° F degrees temperature and 70% relative humidity for each of the test samples. These temperature values were selected to investigate the effect of temperature on strength gain. (60° F and 85° F degrees were considered to be the minimum and maximum temperature values for a typical concrete placement project.) The materials and the water were placed in the chambers 24 hours prior to mixing in order to bring their temperature levels to a constant temperature.

The following list indicates how this program was carried out in the laboratory.

1. The materials were mixed by using a mechanical mixer.

2. The mixture was placed into the molds.
3. The thermocouples for thermometer and maturity-meter were placed three inches into the wet concrete at the ends.
4. The concrete specimens were placed in the environmental chambers.
5. The maturity and temperature values of the specimens were recorded. The maturity values were calculated by using the Nurse-Saul equation with a datum temperature value of  $-10^{\circ}\text{C}$ .
6. Single point loading test was performed with the cured specimens. The maturity and the strength values were recorded for further mathematical analysis.

Eight concrete specimens (2 sets) were cast in 6" x 6" x 20" beam molds. The specimens were cast and cured for 48 hours in these environmental chambers. Different curing temperatures were used to validate the effect of temperature on the relationship between maturity and strength. Beams were tested at various time intervals within the 48-hour curing period. The specimens were tested in four main time intervals:

1st interval	6-8 hours
2nd interval	12-13 hours
3rd interval	24-26 hours
4th interval	46-48 hours

The beam break tests were carried out by a hydraulic loading device. The tests were conducted according to TxDOT procedure Tex-420-A (single point loading test).

## Results

The results from these tests are displayed in Table 3 for  $60^{\circ}\text{F}$  chamber specimens and on Table 4 for  $85^{\circ}\text{F}$  chamber specimens. Detailed time, temperature, and maturity values recorded during the laboratory tests are displayed in Table C-1 for  $60^{\circ}\text{F}$  samples, and in Table C-2 for  $85^{\circ}\text{F}$  samples, in Appendix C.

**Table 3. Test Results for 60° F Chamber Specimens**

<b>Test No:</b>	<b>Time (hrs)</b>	<b>Maturity (°C-hrs)</b>	<b>Strength (psi)</b>
1	8:00	215	_*
2	12:00	319	259
3	25:13	658	433
4	47:35	1212	656

\* This specimen failed before a reasonable amount of load was exerted on it.

**Table 4. Test Results for 85° F Chamber Specimens**

<b>Test No:</b>	<b>Time (hrs)</b>	<b>Maturity (°C-hrs)</b>	<b>Strength (psi)</b>
1	7:35	271	120
2	12:30	466	319
3	25:43	984	490
4	48:05	1843	651

Time versus strength and maturity versus strength data were displayed in Figure C-1 and Figure C-2 for 60° F samples, and Figure C-3 and Figure C-4 for 85° F samples, in Appendix C. The test results show that the strength development rate was higher for samples that were cured in the 85° F chamber.

Next, it is of interest to analyze these test results and to find the best fitting mathematical model that would represent the strength-maturity relationship. As mentioned earlier, different mathematical models should be statistically tested to find the best fitting model. After finding the best fitting model, the parameters of this strength-maturity equation could be calculated.

### **Evaluation of Strength-Maturity Relationship**

Several different mathematical models are available to represent strength-maturity relationships as mentioned in the literature review. The laboratory test results were statistically analyzed in order to evaluate the adequacy of these models for representing

the strength-maturity relationship. In this section several models are analyzed and compared.

### Strength-Maturity Relationship

Regression analysis is a statistical method based upon minimum sum of squares errors which can be used to find the coefficients of a given model form. The coefficients of the equation are decreased or increased systematically to find the best fit equation which has minimum variation from the data. Kaleidagraph (25) is a computer program that can be used to perform this type of regression analysis and to find the coefficients of different forms. The regression statistics include the  $R^2$  value which is referred to as the coefficient of determination that indicates the goodness of fit ranging between '0' and '1'. The higher the coefficient of determination, the better the fit.

Mathematical models that are considered in this evaluation are those proposed by different scientists and engineers previously reviewed in chapter two. These models are listed below:

$$\text{Model 1: } S = S_{\infty}(1 - e^{-kM})$$

$$\text{Model 2: } S = a + b \log(M)$$

$$\text{Model 3: } S = S_{\infty} \frac{K(M - M_0)}{1 + K(M - M_0)}$$

$$\text{Model 4: } S = \frac{S_{\infty}}{1 + D[\log(M - 16.7)]^b}$$

$$\text{Model 5: } S = S_{\infty} e^{-\left[\frac{r}{M}\right]^p}$$

### Regression Analysis and Results

Regression analysis were separated for the different curing conditions. The limiting strength and the coefficient of determination values are shown in Table 5.

**Table 5. Results of Regression Analysis of Different Models**

<b>temperature</b>	<b>0°</b>	<b>F</b>	<b>5°</b>	<b>F</b>
<b>odel</b>	<b>imiting trength ∞ (psi)</b>	<b>oefficient of etermination R<sup>2</sup>)</b>	<b>imiting trength ∞ (psi)</b>	<b>oefficient of etermination R<sup>2</sup>)</b>
	61.48	.99666	99.14	.98406
		.99280		.99519
	045.2	.98118	37.54	.99486
	085.1	.97895	79.86	.99369
	55.25	.98128	16.83	.99544

The model that has the highest coefficient of determination fits to the data best, as previously mentioned, but it is evident that very little difference exists between them. Model 1, among all the other models, fit best to the data obtained from the samples cured at 60° F chamber. Likewise, model 5 fit best to the data obtained from the samples cured at 85° F chamber.

Carino (13) mentioned that for strength below about 50% of the limiting strength, all the models accurately describe the strength development. However, at higher strength levels the relationship proposed by Nykanen, model 1, and by Plowman, model 2, do not model strength gain as accurately as the others. Moreover, model 2 predicts ever increasing strength with increasing maturity, which is theoretically and practically not correct. Moreover, the relationship is not valid at very early maturities and only intermediate maturity values result in an approximately linear relationship between strength and the logarithm of maturity. Therefore model 1 and model 2 are not proper representations of the strength-maturity relationship.

Model 5 has the highest coefficient of determination among the remaining valid models. This model is the best fit model for the data obtained by testing the samples cured both at 60° F and 85° F chambers. Therefore, model 5 can be used to present the relationship between strength and maturity with a high level of confidence.

## **DETERMINING LIMITING STRENGTH**

Since the curing temperatures were different for each set of specimens, the limiting strength values were expected to be different as previously discussed. Although the strength-maturity relationship is unique for a specific mixture, the maturity-strength relationship remains the same regardless of the temperature. However, the limiting strength values should be different for the specimens that were cured in different environmental chambers. Therefore, the analysis of strength-maturity data to find the limiting strength was conducted separately for the samples that were cured in different environmental chambers.

### **Regression Method**

Almost all of the models, except model 2, include a limiting strength parameter. As mentioned earlier, the relationship in model 2 predicts ever increasing strength with increasing maturity. Therefore, according to this relationship there would be no limiting strength.

As a result of the regression analysis, the limiting strength values according to each model were also predicted. The limiting strength values predicted by regression analysis is presented in Table 5. As seen in the table, the limiting strength values of specimens cured at 60° F were higher than of those cured at 85° F. All of the limiting strength values were relatively close to each other. However, the results from regression analysis of model 5 was used to calculate the limiting strength for consistency purposes.

### **Reciprocal Method**

Another mathematical method that can be used for finding the limiting strength is the reciprocal method. The reciprocal method is method is based upon the hyperbolic equation proposed by Kee (19) in 1971.

$$S = \frac{M}{\frac{1}{A} + \frac{1}{S_{\infty}}} \quad (9)$$

This equation can be rewritten as follows:

$$S = \frac{1}{\frac{1}{AM} + \frac{1}{S_{\infty}}} \quad (9-a)$$

$$\frac{1}{S} = \frac{1}{AM} + \frac{1}{S_{\infty}} \quad (9-b)$$

$$\frac{1}{S} = \frac{1}{S_{\infty}} + \frac{1}{A} \cdot \frac{1}{M} \quad (9-c)$$

As seen from Equation (9-c), there is a linear relationship between the reciprocal of strength and the reciprocal of maturity. Also, this equation reveals that the intercept value is the reciprocal of the limiting strength.

The reciprocal method makes use of Equation (9-c) which proposes a linear relationship between the reciprocal of strength and the reciprocal of maturity. In this method, the reciprocals of strength values were plotted against the reciprocal of maturity values in a scatter chart. A trend line was plotted among the data points by using the least squares linear regression method. The intersection of the trend line and the strength axis corresponds to a point where the reciprocal of the strength value is zero. When the reciprocal of a mathematical figure is zero, this implies that this figure converges to infinity.

$$\lim_{x \rightarrow \infty} \frac{1}{x} = 0 \quad (10)$$

The graphical implementation of this method is presented in Figure 4.



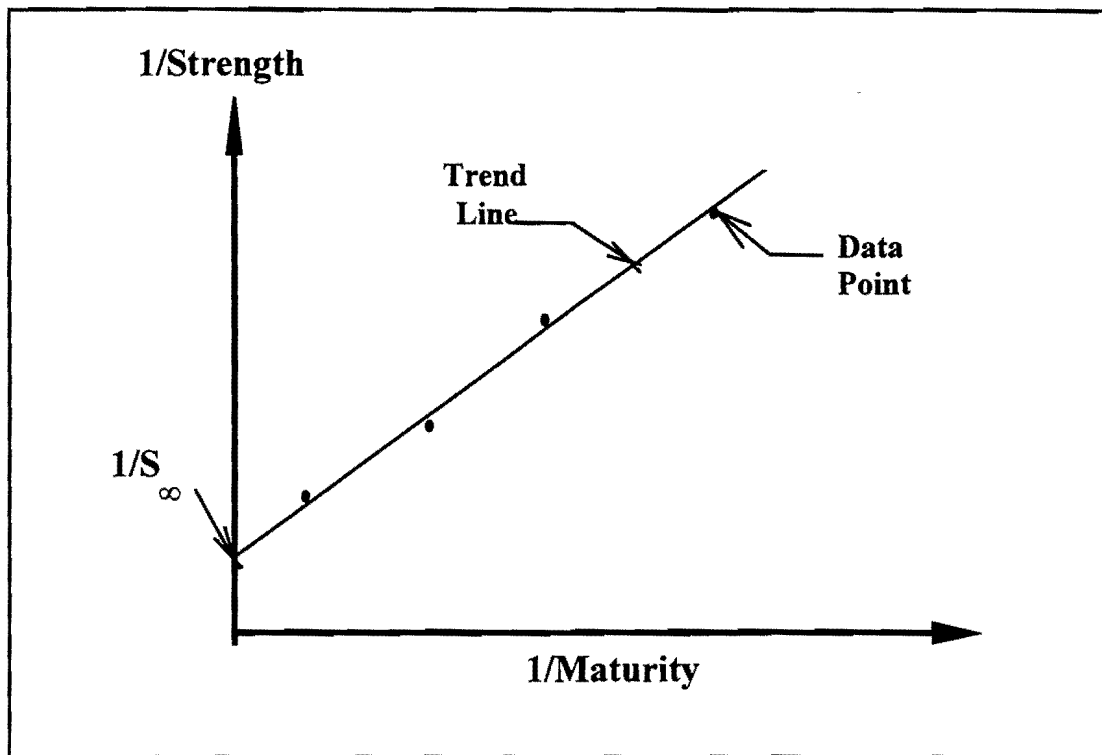
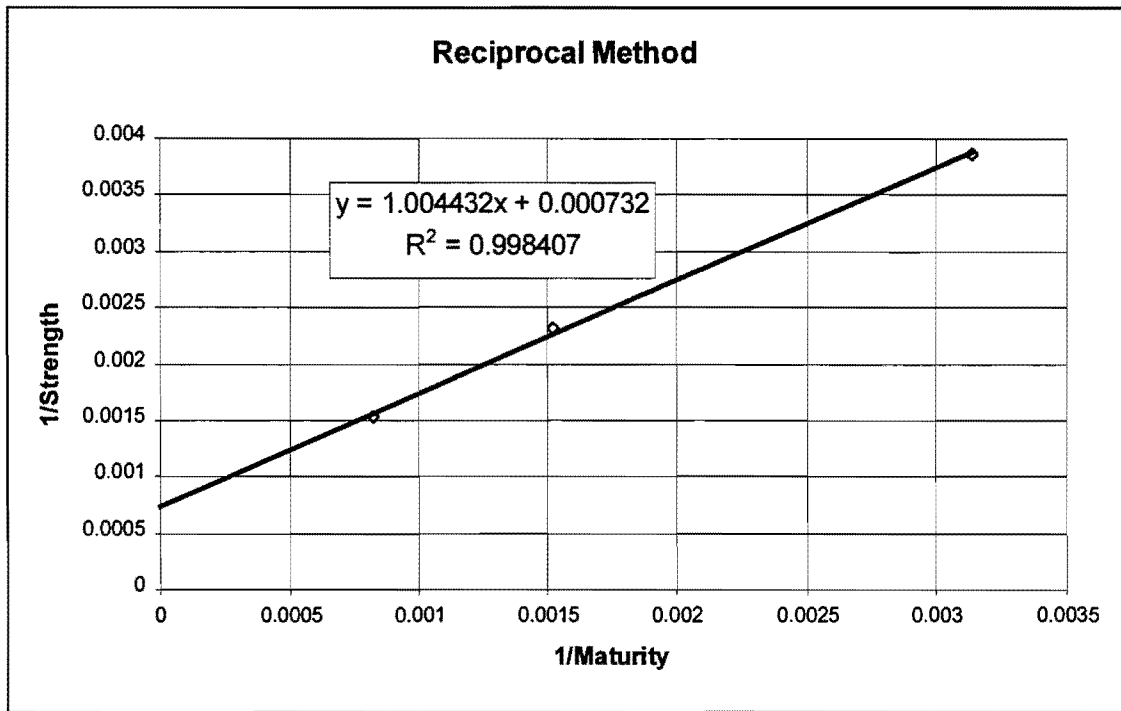

**Figure 4. Reciprocal Method**

The reciprocal method can be applied to the data which were obtained from the laboratory tests. As discussed in the literature review, the limiting strength values of concrete should be different for the specimens that were cured in different environmental conditions. Hence, the analysis for finding the limiting strength should be done separately for samples cured in different environmental conditions.

*60° F Chamber*

Limiting strength was predicted as 1366 psi for the concrete specimens that were cured in 60° F environmental chamber. The chart presenting reciprocal method analysis for specimens cure at 60° F is presented in Figure 5.



**Figure 5. Reciprocal Method for Specimens Cured at 60° F**

*85° F Chamber*

Then same method was applied to the data obtained from the specimens cured at 85° F chamber. However, the trend line intercepted the strength axis at a negative point. This result was not appropriate since the limiting strength value could not be negative. The chart representing the reciprocal method analysis for specimens cured at 85° F is presented in Figure 6.

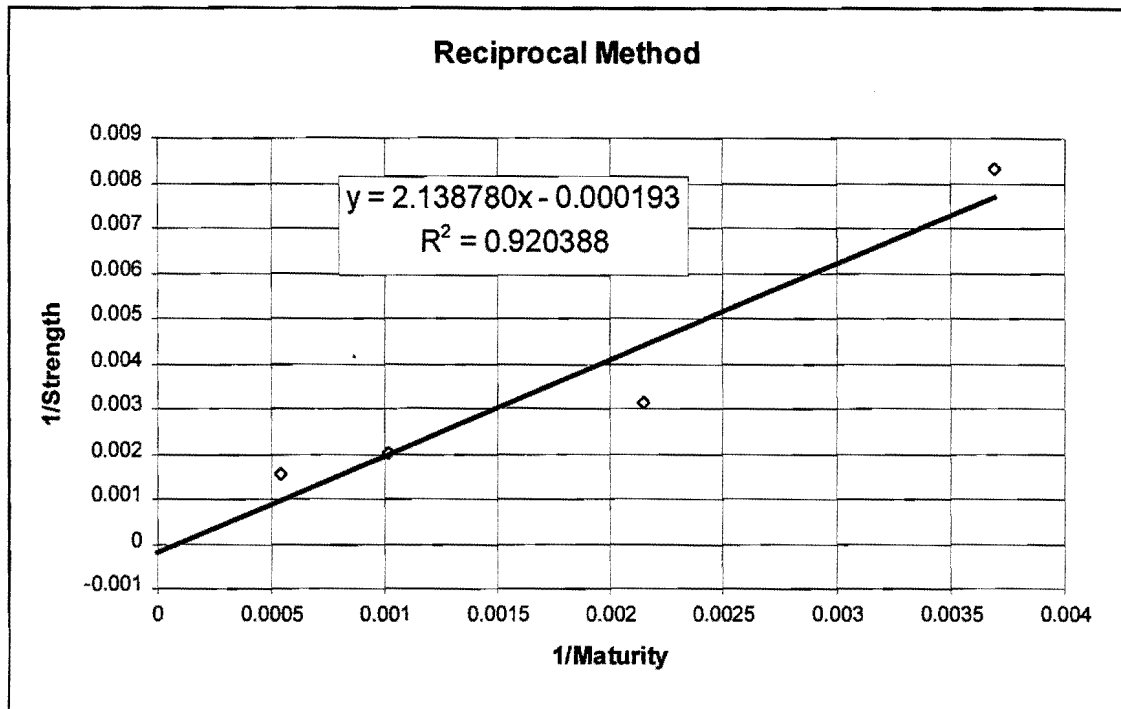
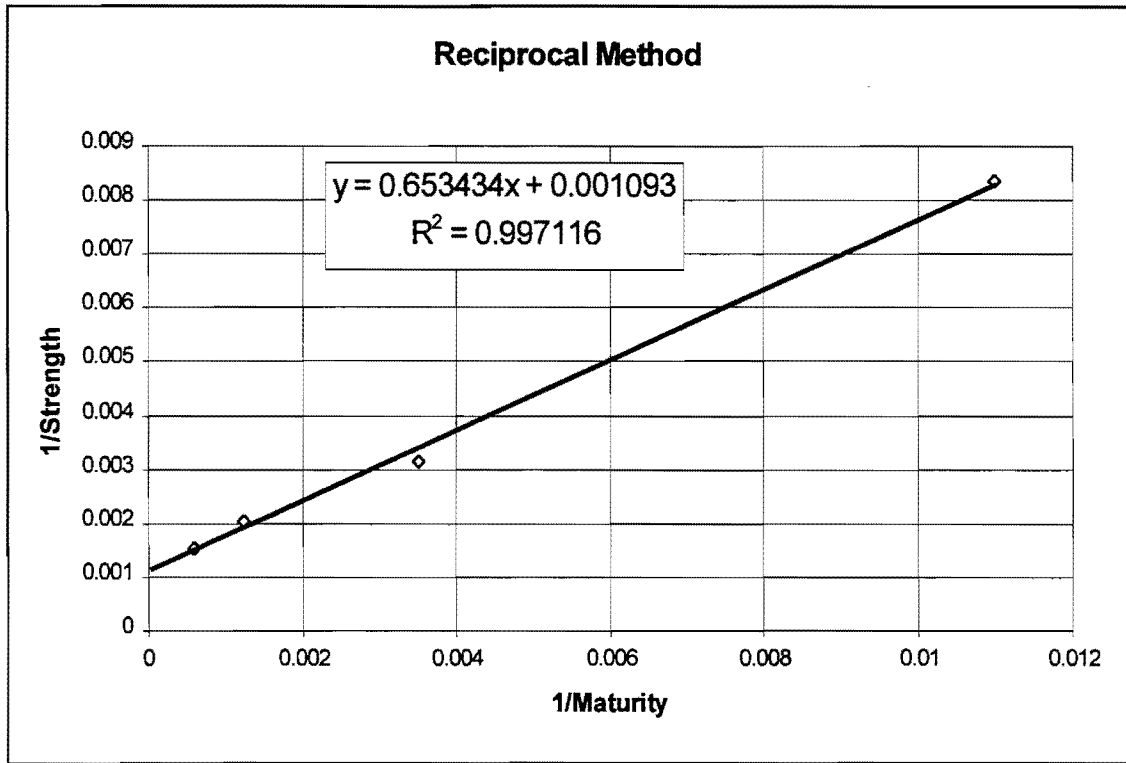

**Figure 6. Reciprocal Method for Specimens Cured at 85 °F**

McIntosh (11) suggested that the strength development does not start until a certain amount of maturity is reached. He introduced an “offset” maturity,  $M_0$ , to account for the fact that strength development does not begin until a finite value of maturity has been reached. The equation proposed by Bernhardt should be modified in such a way that the offset maturity values could be taken into account. Later, Carino (20) proposed a modified equation as follows:

$$\frac{1}{S} = \frac{1}{S_\infty} + \frac{1}{A} \cdot \frac{1}{(M - M_0)} \quad (11)$$

This equation is the same equation as Equation 15. The parameters have been calculated by doing a regression analysis of model 3. The value of  $M_0$  was calculated to be 180° C-hr. The reciprocal method can be applied to the data after the maturity values are modified by subtracting the  $M_0$  from the original values. The modified version is displayed in Figure 7.



**Figure 7. Modified Reciprocal Method for Specimens Cured at 85° F**

Limiting strength is predicted to be 915 psi for the concrete specimens that were cured in 85° F environmental chamber. The analysis yielded a reasonable result for the 60° F samples since the  $M_0$  value was already zero as calculated in model 2.

Although this model is convenient to use and does not require multi-variable regression analysis, the results are not accurate when the  $M_0$  value is not equal to zero.  $M_0$  could be calculated by using multi-variable regression analysis. However, the reciprocal model becomes difficult to implement without knowing the offset maturity values. Without calculating offset maturity, incorrect limiting strength values may be obtained by using the reciprocal method. However, from the results of the regression analysis the offset maturity value was predicted to be '0' for the specimens cured at 60° F chambers, where it was '180' for the specimens cured at the 85° F chambers. Further tests and analysis should be done to evaluate the relationship between curing temperature and offset maturity.

As a conclusion, the limiting strength values should be calculated by using a multi-variable regression analysis. Kaleidagraph (25) can be used to find the parameters of strength-maturity models (model 3, model 4, and model 5). The statistically best fit model should be used to represent the strength-maturity relationship. Also, the value of the parameter that corresponds to the limiting strength in the best fit model should be used as the limiting strength value.

In this study, model 5 was the best fit among all the valid models. Thus, the limiting strength should be predicted by using the regression analysis results of this model. The regression analysis yielded a limiting strength value of 955.25 psi for specimens cured at 60° F chamber and 816.83 psi for specimens cured at 85° F chamber.

## DEMONSTRATION OF TEMPERATURE INDEPENDENT STRENGTH-MATURITY RELATIONSHIP

The results of regression analysis showed that the mathematical model proposed by Freisleben Hansen and Pedersen can be used as a proper presentation of strength-maturity relationship (16). This relationship is simple and accurate and it can be rewritten to form a temperature independent model. Temperature independence, combined with its simplicity and accuracy makes it possible to be used in the field.

$$S = S_{\infty} e^{-\left[\frac{\tau}{M}\right]^a} \quad (12)$$

This equation can be modified into a much more form, as follows:

$$\frac{S}{S_{\infty}} = e^{-\left(\frac{\tau}{M}\right)^a} \quad (13-a)$$

$$\text{Ln}\left(\frac{S}{S_{\infty}}\right) = -\left(\frac{\tau}{M}\right)^a \quad (13-b)$$

$$\text{Ln}\left(-\text{Ln}\left(\frac{S}{S_{\infty}}\right)\right) = a\text{Ln}\left(\frac{\tau}{M}\right) \quad (13-c)$$

$$\text{Ln}\left(-\text{Ln}\left(\frac{S}{S_{\infty}}\right)\right) = a(\text{Ln}\tau - \text{Ln}M) \quad (13-d)$$

$$\text{Ln}\left(-\text{Ln}\left(\frac{S}{S_{\infty}}\right)\right) = a\text{Ln}\tau - a\text{Ln}M \quad (13-e)$$

Equation 13-e reveals that there is a linear relationship between natural logarithm of the maturity and double natural logarithm of the relative strength. When the limiting strength is calculated, this value can be used to calculate the relative strength values of specimens. The double logarithm of the relative strength values will yield values that correspond linearly to the logarithm of the concrete maturity as described in Equation 13-e.

Calculations for the specimens cured in 60° F chamber were displayed in Table 6. The limiting strength for the concrete cured at 60° F was predicted as 955.25 psi, as mentioned earlier. The data points and the corresponding trend line were plotted in Figure 8.

**Table 6. Calculations for 60° F Data**

<b>Maturity (°C-hr)</b>	<b>Strength (psi)</b>	<b>Relative Strength S/Sult</b>	<b>Ln (Maturity)</b>	<b>Ln (-Ln(S/Sult))</b>
319	259	0.2711	5.7652	0.2663
658	433	0.4533	6.4892	-0.2342
1212	656	0.6867	7.1000	-0.9787

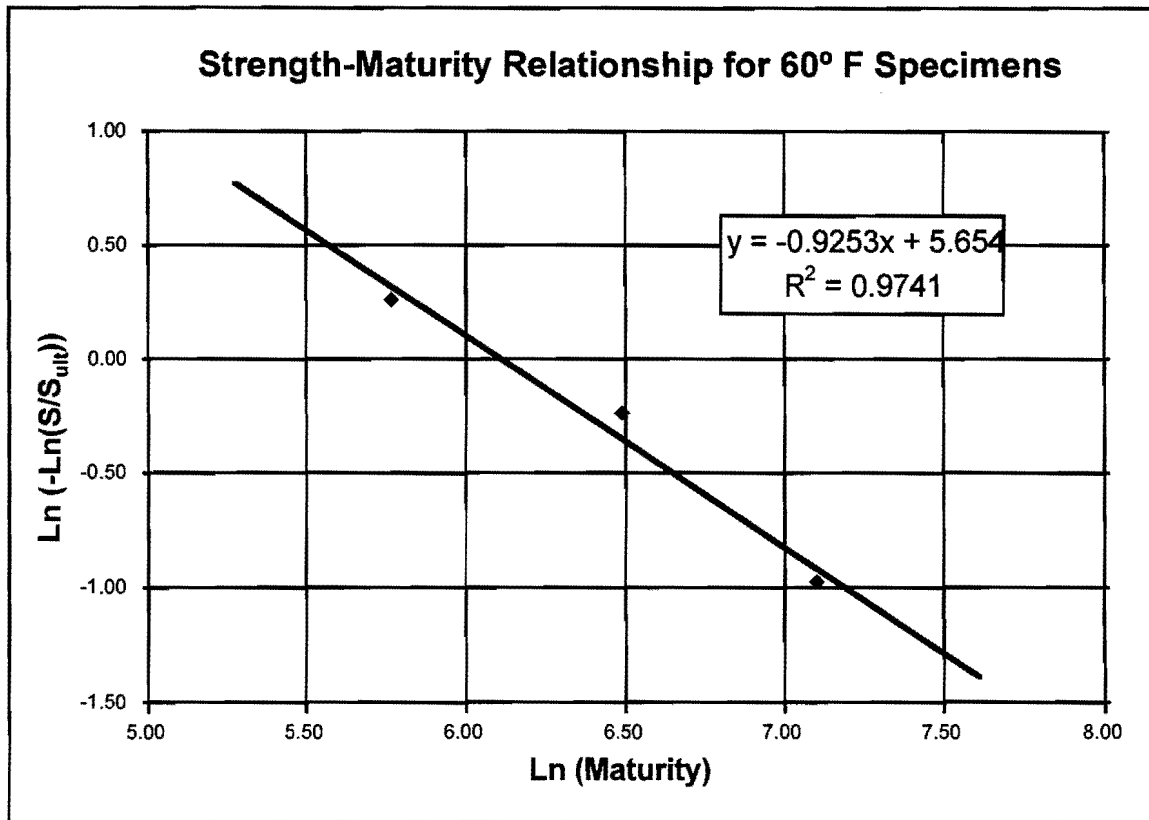
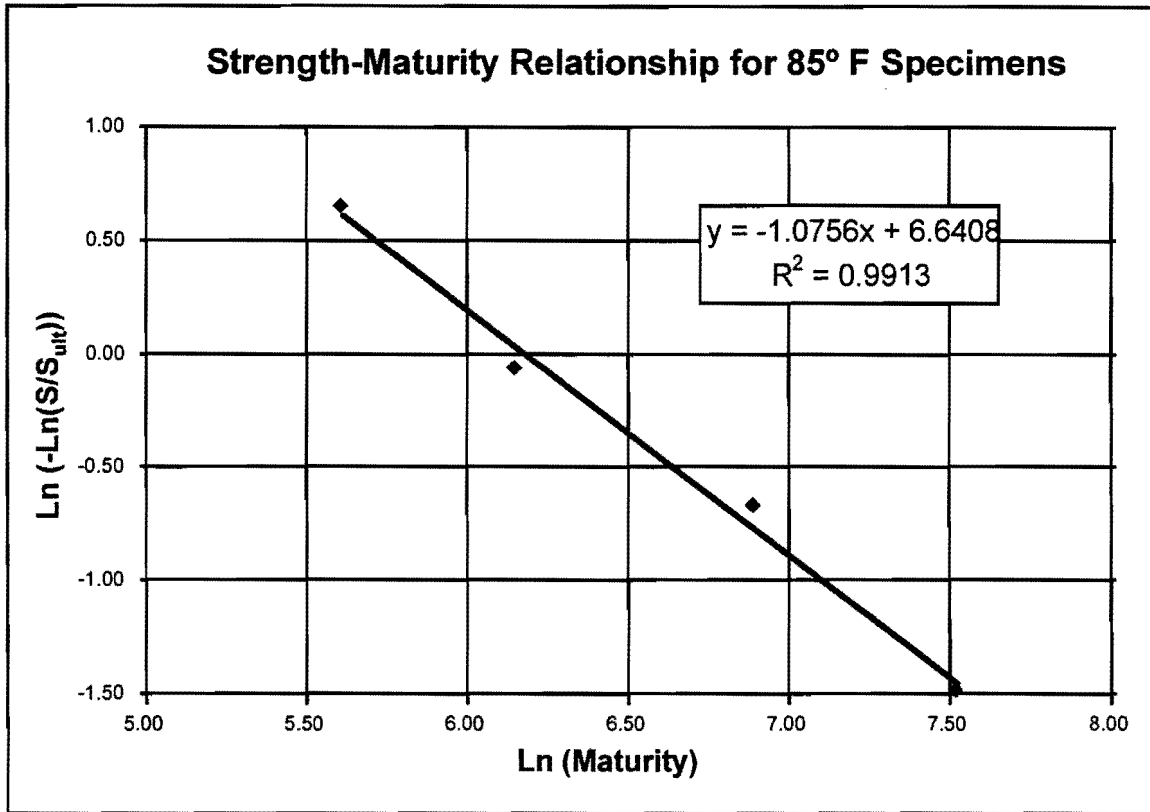

**Figure 8. Strength-Maturity Relationship for 60° F Specimens**

The same calculations are made for the data collected from the specimens cured in 85° F chamber. The calculations are shown in Table 7. The limiting strength for the concrete cured at 85° F was predicted as 816.25 psi, according to model 5. The data points and the corresponding trend line are plotted in Figure 9.

**Table 7. Calculations for 85° F Data**

<b>Maturity (°C-hr)</b>	<b>Strength (psi)</b>	<b>Relative Strength S/Sult</b>	<b>Ln (Maturity)</b>	<b>Ln (-Ln(S/Sult))</b>
271	120	0.1470	5.6021	0.6509
466	319	0.3908	6.1442	-0.0624
984	490	0.6003	6.8916	-0.6727
1843	651	0.7975	7.5191	-1.4863



**Figure 9. Strength-Maturity Relationship for 85° F Specimens**

The linear regression analysis yielded a relation of  $y = -0.9253x + 5.654$  for 60° F specimens and  $y = -1.0756x + 6.6408$  for 85° F specimens. The slopes and intercept values are very close to each other. This result is consistent with the hypothesis that the strength-maturity relationship is only mixture dependent.

In order to check whether the strength-maturity relationships are unique for a given mixture proportion or not, confidence interval tests were carried out. This statistical test evaluates whether it is reasonable to conclude that the strength-maturity equations obtained for different curing conditions are the same or not. The statistical tests for evaluating the variation of the intercept and slope values for different temperatures are shown in Appendix D.

In both of the statistical tests, the hypothesis that these two equations were the same equation with a 5% level of significance could not be rejected. Therefore, this means that these relationships are statistically the same. This conclusion also supports



the hypothesis that the relationship between the double logarithm of the relative strength and logarithm of the maturity is independent of curing temperature and unique for the same mixture proportion.

As a result of these analysis, it was found that the slope and intercept values obtained by analyzing the 60° F data were within the 90% confidence interval of the values obtained by analyzing 85° F data. Likewise, the slope and intercept values obtained by analyzing the 85° F data were within the 90% confidence interval of the values obtained by analyzing 60° F data.

Consequently, it was concluded that the strength-maturity relationships were the same at a significant level of 5%. Therefore, the data obtained from 60° F chamber and from 85° F chamber could be combined. All the data are plotted together in one graph on Figure 10.

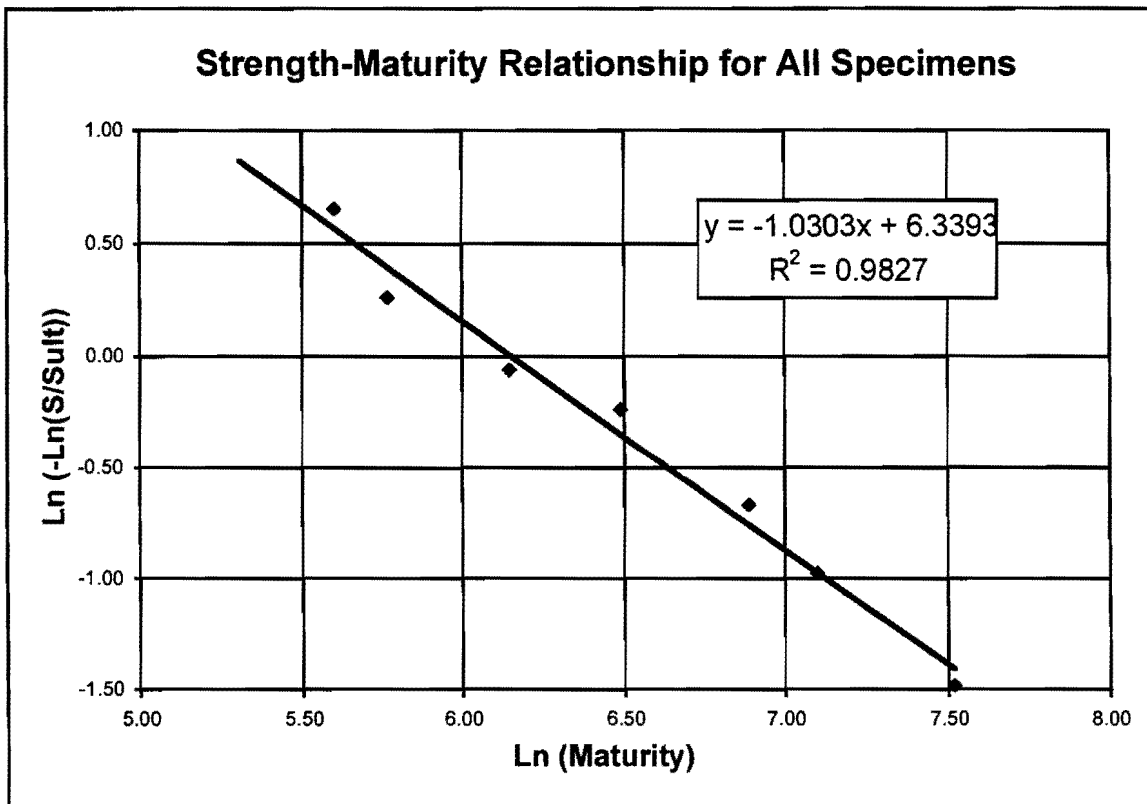

Figure 10. Strength-Maturity Relationship for all Specimens

The coefficient of determination for the combined relationship was rather high. This fact also supports the temperature independent strength-maturity relationship.

## **CONCLUSION**

As a result, it is reasonable to suggest that the linear relationship between the natural logarithm of the maturity and double natural logarithm of relative strength is independent of curing temperature. This is a very important conclusion, because once the strength-maturity relationship is obtained for a given mixture design, this relationship could be used for any curing condition whether constant or variable. When the limiting strength is obtained for a concrete specimen than the strength-maturity relationship can be utilized to find the opening maturity.

The strength-maturity relationships were developed by analyzing the laboratory test data. The laboratory specimens were cured at a temperature controlled environment. The next question is whether this strength-maturity relationship is applicable to field conditions where temperatures change during the curing period.

# **DEVELOPMENT OF CONTRACTOR INTERACTION AND CONSTRUCTION COMPONENTS**

## **INTRODUCTION**

Several key concepts were considered important to developing the construction component of the process model framework for 72 hour intersection reconstruction. First, close interaction with the contractor is required to successfully implement the design. Second, construction sequencing and methods must support completion of the intersection within a 60 hour time frame. Third, flexural strength of concrete pavement is a critical driver for opening and must be planned and managed during construction. These three concepts were addressed through the construction component of the process.

A third demonstration project provided a vehicle to evaluate the application of these three key concepts. This project assisted the research team in understanding how construction management techniques, construction methods, and materials management techniques are applied. Further, the demonstration project provided a basis for development of specific steps in the model and identifying key information required to perform these steps. This latter assessment enabled the research team to develop details of the process model framework and then convert these details into usable guidelines.

In order to develop the contractor interaction and construction components of the process model framework, both the research team and TxDOT agreed that one demonstration project should be reconstructed. Of the three demonstration projects studied, the Chasewood Park Drive intersection was the only candidate for reconstruction. The research team began work after the project had been let and the contractor had been chosen. Despite the small size of this intersection, it provided valuable insight into design and construction alternatives to be used in full-size intersections. This development also aided in the formulation of the contractor interaction and construction components of the 72 hour intersection reconstruction guidelines. The following sections discuss the results of the Chasewood Park Drive intersection reconstruction effort.

## **CONSTRUCTION CONCEPTS**

This section provides an analysis of the construction concepts applied and implemented with the Chasewood Park Drive / SH 249 intersection demonstration project. The section focuses on seven main topics: alternate construction methods, proposed construction method, revised construction method, actual construction method, general comparisons, summary, and recommendations.

The intersection selected for the demonstration project is located at Chasewood Park Drive and SH 249 in Houston, Texas. Reconstruction of this intersection is part of construction of a new pavement system for SH 249. Chasewood Park Drive is a “T” intersection and serves as an entrance to COMPAQ Computer Co. Although this intersection did not truly represent the type of intersection of real interest in this research, it posed challenges that provided valuable information.

The Chasewood intersection was selected by the Houston District of TxDOT for several reasons. Chasewood posed a unique opportunity to test accelerated intersection reconstruction concepts and techniques with limited construction restrictions. The intersection had a traffic pattern that enabled complete closure to traffic during construction. The size of the intersection also fit within the desired framework to ensure completion of construction within a weekend. The Chasewood intersection contained a number of different construction elements to consider such as: tie-ins to both existing and new pavement; removal of concrete and asphalt pavement; significant excavation due to a profile differential, and a construction area with limited room to operate. Figure E-1 shows a plan view of the new Chasewood Park Drive intersection.

## **ALTERNATE CONSTRUCTION METHODS**

Five alternatives for reconstructing the Chasewood intersection were originally proposed. These five options were:

1. 8” CRC pavement on lime and cement stabilized bases,
2. 11” CRC pavement on prepared subgrade,
3. 8” CRC pavement on asphalt base,

4. 11” CRC pavement on prepared subgrade - pumped and placed with a bidwell screed, and

5. 11” CRC pavement on prepared subgrade - pumped and placed with a vibrating screed.

Each of the five proposed options shared two main similarities: 1) a total scheduled duration of less than 72 hours; and 2) full closure of the intersection throughout construction. Each method was based on the criteria that construction would be completed over the weekend with the closing of the intersection beginning on Friday at 7:00 p.m. The intersection would then be reopened at a time determined by the scheduled duration for each option. Table 8 shows a summary of the five proposed alternatives.

**Table 8. Intersection Reconstruction Alternatives**

<b>Approach</b>	<b>Estimated Intersection Opening</b>	<b>Estimated Duration (hrs)</b>	<b>Estimated Total Cost (\$)</b>	<b>Cost/Time Ratio (\$/hr)</b>
Conventional	Mon, 3:00 pm	71	55,400	781
Fast-Track	Mon, 3:00 am	58	49,800	857
Asphalt Base	Mon, 12:00 pm	67	59,800	893
Pumping w/ Bidwell	Mon, 2:00 am	57	53,100	930
Pumping w/ Vibrating Screed	Sun, 8:00 pm	51	52,200	1,023

A cost and time comparative analysis was then completed with the purpose of selecting the best possible option. This analysis was then reviewed by TxDOT and the contractor that would perform the construction. After reviewing the options, a change was made to the research project scope. TxDOT wanted the construction completed by 6:00 AM Monday morning. Although the title of the research project implies a 72 hour construction duration, the actual time span for a 6:00 AM Monday opening is reduced to 60 hours. Using this as a limiting criteria, only three of the five options could meet the

opening requirements: 11” CRC pavement on prepared subgrade; 11” CRC pavement on prepared subgrade - pumped and placed with a bidwell screed; and 11” CRC pavement on prepared subgrade - pumped and placed with a vibrating screed. Figure 11 summarizes the five approaches with their respective costs represented by bars and their total duration represented by a line. Note that the conventional method and the asphalt alternatives have their time line above the critical 59 hour line.

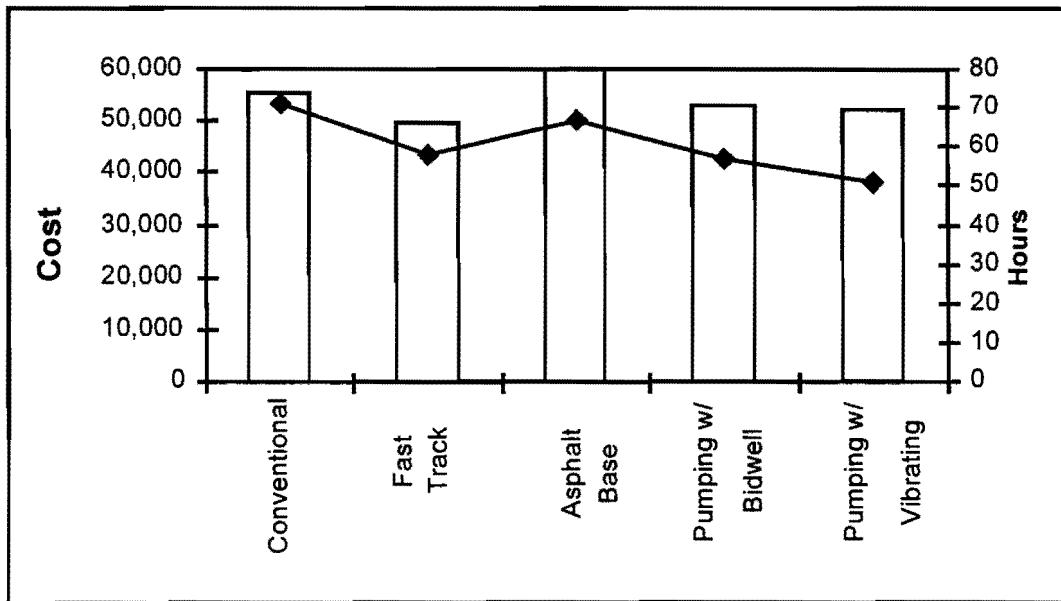

**Figure 11. Time-Cost Analysis Results**

The remaining three options all proved to be adequate methods to accomplish the intersection reconstruction in a 60 hour project duration. However, the contractor favored the two options that used the mechanized screeds, particularly the method that utilized the vibrating screed. Although all three available options could be used successfully to reconstruct the intersection, the method with the shortest construction duration would be most beneficial to the success of the project. The shortest duration would give the project much needed float, or time contingency, that would accommodate for any unseen problems that might arise. The option that had the shortest duration of the three remaining alternatives was the 11” CRC pavement on prepared subgrade - pumped and placed with a vibrating screed.

## **PROPOSED CONSTRUCTION METHOD**

After meeting with TxDOT and the contractor, two construction options were officially recommended: 11” CRC pavement on prepared subgrade - pumped and placed with a bidwell screed, and 11” CRC pavement on prepared subgrade - pumped and placed with a vibrating screed. The research team provided a mix design and curing method necessary to accelerate the curing process to meet estimated curing times stipulated in the schedules for these two options.

The vibrating screed alternative proved to be the closest option to what would actually be constructed. This method required closing the intersection at 7:00 PM on Friday and reopening the intersection at 8:00 PM, Sunday evening, with a total scheduled duration of 51 hours. All concrete pours were designed to be pumped and placed with a vibrating screed. Both the curbs and concrete island were also scheduled to be placed prior to opening.

Four different labor crafts were required with the vibrating screed method: demolition/excavation; formwork; reinforcing steel; and concrete placement. A total of 343 labor hours was estimated for construction. Sequencing of the project was phased in four sections, each of which were 25’ wide. The total estimated unit cost for the vibrating screed method was \$36.25/SY of pavement area placed. This estimate included the cost of materials, labor, equipment, contingency, overhead, and profit. Figure E-2 and Table E-1 in Appendix E show the schedule and cost estimate, respectively, for the proposed vibrating screed construction option.

### **Revised Construction Method**

A revised construction phasing and sequencing plan was proposed by the contractor. Their construction plan and estimate was based on a modified version of the vibrating screed method. The modification replaced the vibrating screed with an air screed. Moreover, the contractor’s construction plan omitted placing curbs and the

island. Instead, both would be placed after weekend reconstruction was completed. This change allowed more time for actual pavement construction. The last significant difference between the two plans occurred with the placement of the pavement radiuses (the pavement area that provides the motorist with a curved right turn). The proposed method incorporated the radiuses into the major pours where as the revised plan called for each radius to be poured separately. The revised construction phasing and sequencing is shown in Figure E-3 in Appendix E

Table E-2 displays the estimate submitted by the contractor for their revised construction approach. Their estimate included a 25% contract fee as a result of the Chasewood Park Drive intersection being constructed over a weekend. This represented a scope change from the construction method included in the contractor's bid for the work that covered this intersection. The change in method resulted in a unit price of \$76.18 per SY of pavement area. By eliminating the contract fee, a more realistic unit price is \$60.85 per SY. The contractor's estimate was significantly higher than the research team's estimate of \$36.25 per SY. Main differences between cost estimates are attributed to additional costs for concrete additives, higher cost of labor for weekend and night work, and increased cost of concrete for weekend batch plant operation. These costs were not adequately addressed in the original estimate. Due to the magnitude of these additional costs (approximately \$90,000 change from the equivalent bid pricing), approval by TxDOT for additional funds was required prior to proceeding with construction.

## **ACTUAL CONSTRUCTION METHOD**

### **Pre-Construction Planning**

Early in 1996, approval for the additional funds was received from TxDOT for the construction of the Chasewood Park Drive intersection. Upon receiving the approval, the weekend of March 8, 9, and 10 was scheduled for the construction of the intersection. As



a contingency plan, March 15, 16, and 17 was specified as the alternate weekend in case of inclement weather.

Site logistics required to support construction were analyzed before a final construction schedule was developed. Key logistics issues included analyzing the location of the existing utilities, methods of demolition, crew sizes and sequencing of crews, and materials required. Another important issue was to interface with COMPAQ Computer regarding full closure of the Chasewood Park Drive entrance. Based on analysis of these logistics issues, a detailed schedule of work activities was then completed. Figure E-4 displays the actual schedule that was developed by TxDOT and the contractor for the construction of the intersection.

The overall construction plan focused on completing Sections 1, 2, and 4 by late Saturday (see Figure E-3). The remaining Section (Section 3) would then be completed by Sunday afternoon, allowing for a 16-hour curing time before opening to traffic Monday morning at 6:00 AM. All demolition work would be completed by early Saturday morning. Formwork and reinforcing steel would be placed such that pouring of Sections 1, 2, and 4 could be accomplished in sequence. Work was not scheduled for Saturday night.

## **Schedule**

Reconstruction of the Chasewood intersection was completed on the alternate weekend, March 15, 16, and 17. This schedule change was due to cold weather conditions that occurred prior to and during the weekend of March 8, 9, and 10. Cold temperatures would increase curing time for the concrete mix design specified for construction, thus adversely affecting timely completion of construction.

Actual construction phasing followed the four sections depicted in Figure E-3 in Appendix E. Based on the detailed construction schedule given in Figure E-2 seven major divisions of activities occurred for each phase. The first activity was demolition of existing pavement. This was accomplished using a Hercules concrete breaker and a crane and ball assembly. Once the pavement was demolished, the rubble and cut soil was

removed with two excavators beginning with Sections 1 and 2. Excavated material was hauled off site using an average of six 20 CY dump trucks. Site grading and layout proceeded in a fashion that allowed the formwork crew to form Section 1, while grading was continued simultaneously on the other sections. Reinforcing steel placement began after forming was almost complete on Sections 1 and 2. The concrete mix was designed to provide a cure time of 16 hours per section to obtain the design strength required to open to traffic. Forms could be stripped in 4 hours based on the mix design. The total planned durations for each work activity in the project, as well as actual start and finish times, are summarized in Table E-3 in Appendix E.

Figure E-5 depicts the percent complete versus time for both the planned and actual activity durations. As shown in Figure E-5, construction was completed well ahead of schedule. The total planned duration of the project was 60 hours. The actual duration of the project was 47 hours. This represents a 22 % reduction in time. This time reduction is a direct result of increased production of the concrete crew, and accelerated concrete cure time for Section 3. Based on the planned schedule, it was expected that 113 SY of concrete would be placed per hour, however, 192 SY was placed per hour. Thus, the total duration of the concrete pours was reduced by 42 %. Table E-4 contains the planned and actual crew production rates for construction.

The concrete was placed faster than planned because the majority of all the concrete placed was direct poured instead of the original plan of pumping the concrete. Completing the concrete pours faster enabled the concrete to set ahead of schedule, therefore, all pours dependent on a previous pour could be started ahead of the planned schedule. The reduction in time can also be attributed to the concrete curing faster than the predicted 16 hours on Section 3 (see Figure E-3). This section cured in only 9 hours, 47 % faster than Section 1 that cured in 17 hours. Improvement in cure time was a result of warmer temperatures and direct sunlight during the curing period for Section 3.

## **Manpower**

Four different crews were utilized for the construction of the Chasewood intersection: demolition/excavation; formwork; reinforcement steel; and concrete. Of these four crews, only the reinforcement steel crew was subcontracted. All other work on the project was performed with direct hire labor provided by the contractor. Originally, only one crew was scheduled to perform each work activity because of concern with site congestion. However, due to the uncertainties associated with completing construction on time, two concrete crews were used. Table E-4 also shows the planned and actual crew sizes (number of craft) used for construction.

A total of 498 man-hours were used during the construction of the Chasewood intersection. Figure E-6 shows a manpower profile that represents the distribution of crafts over the complete duration of the project. Peak manpower occurred on the second day, with a total of 35 craft on site (a 23 man concrete crew and a 12 man steel placement crew). The manpower distribution used by the contractor followed the planned schedule (Figure E-4) and increased steadily throughout the construction of each section. This leveled manpower curve allowed for better production and eliminated problems with scheduling labor.

## **GENERAL COMPARISONS**

A comparison between the proposed construction method developed by the research team and the actual construction method used to reconstruct the intersection is presented next. This comparison provides insights useful for developing guidelines for accelerated intersection reconstruction. Significant differences between the proposed method and actual method are enumerated below.

- In the proposed method, the plan was to complete all demolition, excavation, and layout activities prior to start of formwork. Actual construction had these activities occurring concurrently.
- Overall duration for demolition and excavation was about the same.

- Forming, re-bar installation, and pouring were scheduled continuously and in sequence for each section with forming and re-bar installation occurring concurrently under the proposed method. Actual construction had forming and re-bar placement complete for three sections, then pouring occurred for these sections (1, 2, and 4). Forming, re-bar placement, and pouring occurred the next day for the final section.

- The proposed method included curbs and the island. Actual construction omitted these two activities.

- In the proposed method, opening was planned for 42 hours, if curbs and island were excluded. Actual time to opening was 47 hours including a gap between Saturday afternoon and Sunday morning when no construction took place.

- Estimated labor hours for the proposed method was 343. Actual hours used during construction was approximately 498. The proposed method used a mechanized approach to concrete pouring and finishing that required less labor. Also, only one concrete crew was used throughout construction under the proposed method. Two concrete crews were used during actual construction.

- Pumping was used for the proposed approach while actual construction used both pumping and direct pour methods to place concrete. Also, the actual method allowed concrete trucks to drive on proof rolled subgrade and newly poured concrete that had reached the required flexural strength.

- The cost of the proposed approach was \$36.25 per SY of pavement area placed versus \$76.18 per SY of pavement area placed (see earlier discussion of differences between these cost estimates).

## **CONCRETE STRENGTH QUALIFICATION**

A strength-maturity relationship was formulated based on laboratory data. Field work was carried out to investigate the applicability of this relationship to field conditions. The project chosen for the field work was a TxDOT project (Chasewood

Park construction). The mixture proportions that were used in the laboratory were the same as the ones used in the actual construction.

During the field work, concrete beams were cast and cured using the same concrete mixture that was used for the construction of the slabs. The temperature and maturity values of these beams and slabs were recorded with time. Then this data was analyzed statistically to test the applicability of the strength-maturity relationship obtained at the lab.

### Field Work

The Chasewood Park construction consisted of four placements of 11 inch thickness. Placements 1, 2, and were constructed on 16th March 1996, and placement 3 was constructed on 17th March 1996. The lay out of the construction site is illustrated in Figure 12.

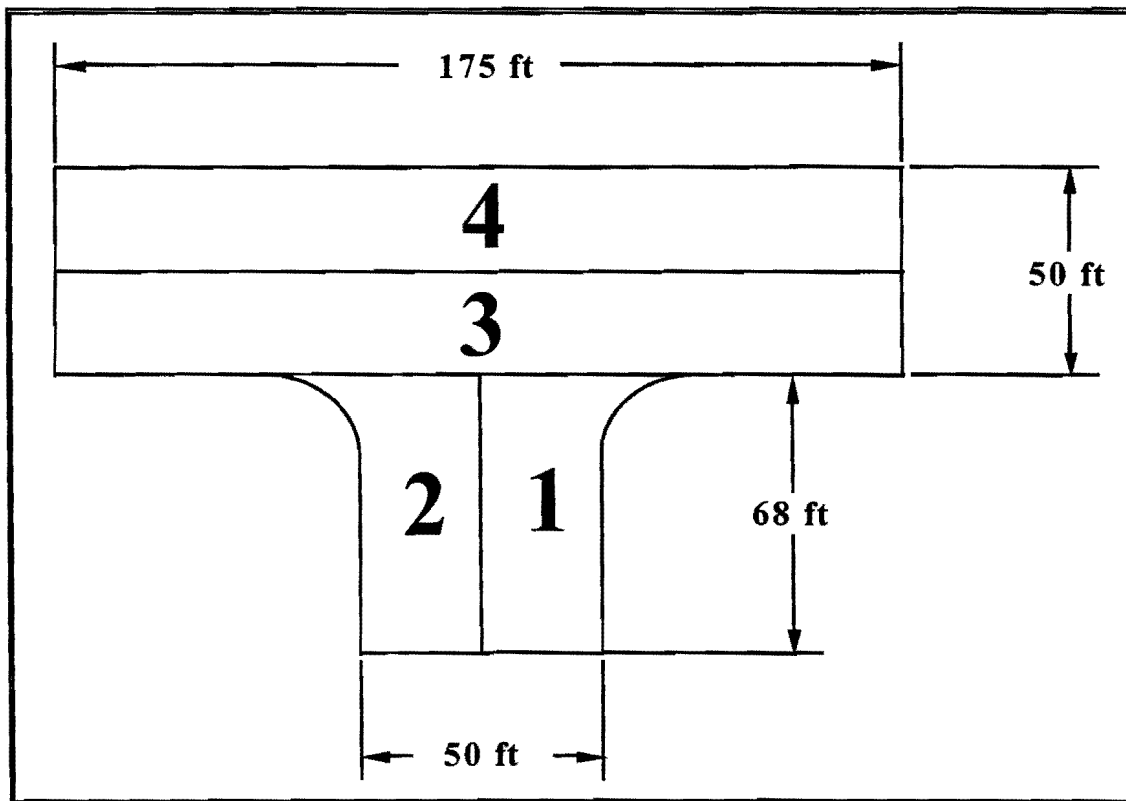
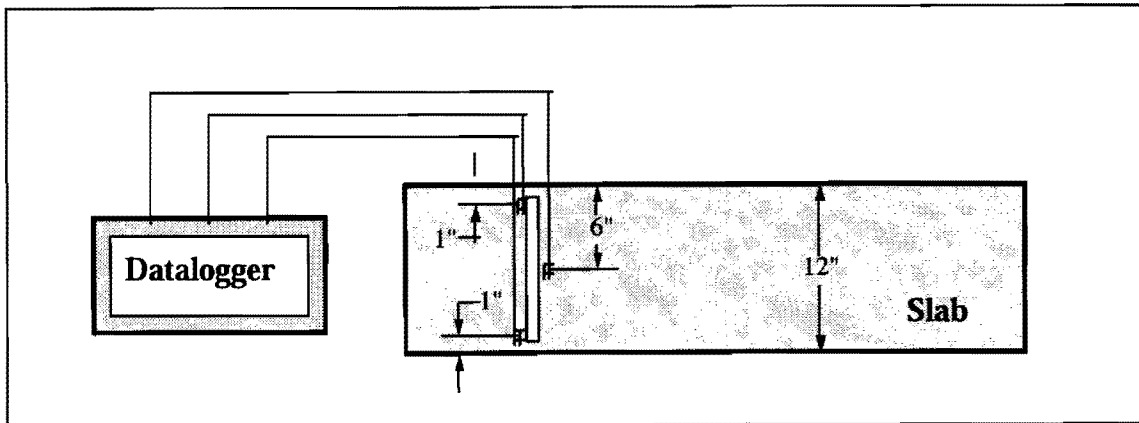

Figure 12. Site Layout

During placement 1, six beam specimens were cast by using the same concrete mixture used for slab 1. These beams were cured in the field by the same curing methods applied for the slabs. The beams were tested by using test method Tex-448-A (third point loading test). Temperature thermocouples were placed in each placement and in one of the beam specimens. Maturity was calculated by using the Nurse-Saul equation with a datum temperature of  $-10^{\circ}\text{C}$ . The temperature of the surface, center and the bottom were recorded by using thermocouples. Maturity was calculated based on the center temperature. Maturity was also obtained using commercially available maturity meters. Typical probe installation is shown in Figure 13.



**Figure 13. Placement of Thermocouples**

On March 17, 1996, slab 3 was poured. Six beams were also cast during the construction of slab 3. Temperature of the surface and the bottom were measured by using temperature thermocouples. Central temperature and maturity were monitored by using a maturity meter. Also, another maturity meter was used to monitor the temperature and maturity of the six beams. The placement of the temperature probes was exactly the same as they were on other placements as shown in Figure 13.

After finishing of the surface the slab, the placement was coated by spraying a curing compound. Then, a polyethylene sheet was used to cover the surface. Finally, cotton mats are were placed over the polyethylene sheet to minimize heat loss in the concrete slab. The beams were also cured by the same method.

The field data that were collected throughout the curing process of concrete placements 1, 2, and 4 and the beam are presented on Appendix F Table F-1, Table F-2, and Table F-3. The data that was collected throughout the curing of placement 3 and the beams are presented in Appendix F, Table F-4.

The beam specimens cast with the 1st, 2nd, and the 4th placements were broken at 9.3, 13, and 25 hours. The corresponding maturity values were also monitored. Each set of beam breaks was used to estimate the limiting strength. The strength and maturity values are presented in Table 9.

**Table 9. Field Data**

<b>Specimen</b>	<b>Maturity (°C-hr)</b>	<b>Strength (psi)</b>
03/16/96@ 9.3 hr Test	332	200
03/16/96@ 13 hr Test	457	370
03/16/96@ 25 hr Test	808	434
03/17/96@ 11.5 hr Test	539	610

The strength required to open the intersection to traffic was 425 psi based on test method Tex-448-A. Therefore, when the strength of the concrete met 425 psi, the intersection was ready for traffic.

### **Calibration of the Strength-Maturity Relationship**

Sets of beam strength tests were done on the 16th of March, 1996. The results from these tests were displayed on Table 10 and were used for statistical analysis of the data. It was previously noted that the strength-maturity relationship is independent of curing temperature and therefore should not vary depending on the varying field curing conditions. This hypothesis can be tested by using a statistical method.

The first step is finding the limiting strength by using model 5. It was concluded that model 5 is a valid mathematical representation of the strength-maturity relationship in previous chapters. The results from these tests were used to perform a regression

analysis. The maturity and strength values that were used for regression analysis are displayed in Table 10. The results from the regression analysis are summarized in Table 11. The graphic representation of the curve fit analysis for model 5 is displayed in Figure 14.

**Table 10. Strength and Maturity of Field Cured Beams**

<b>Beams</b>	<b>Maturity (°C-hr)</b>	<b>Strength (psi)</b>
<b>1</b>	332	200
<b>2</b>	457	370
<b>3</b>	808	434

**Table 11. Regression Results for Field Strength Data**

<b>Model</b>	$S = S_{\infty} e^{-\left[\frac{\tau}{M}\right]^a}$
<b>S<sub>∞</sub> (psi)</b>	870
<b>τ</b>	465.16
<b>a</b>	0.78648
<b>R</b>	0.91575



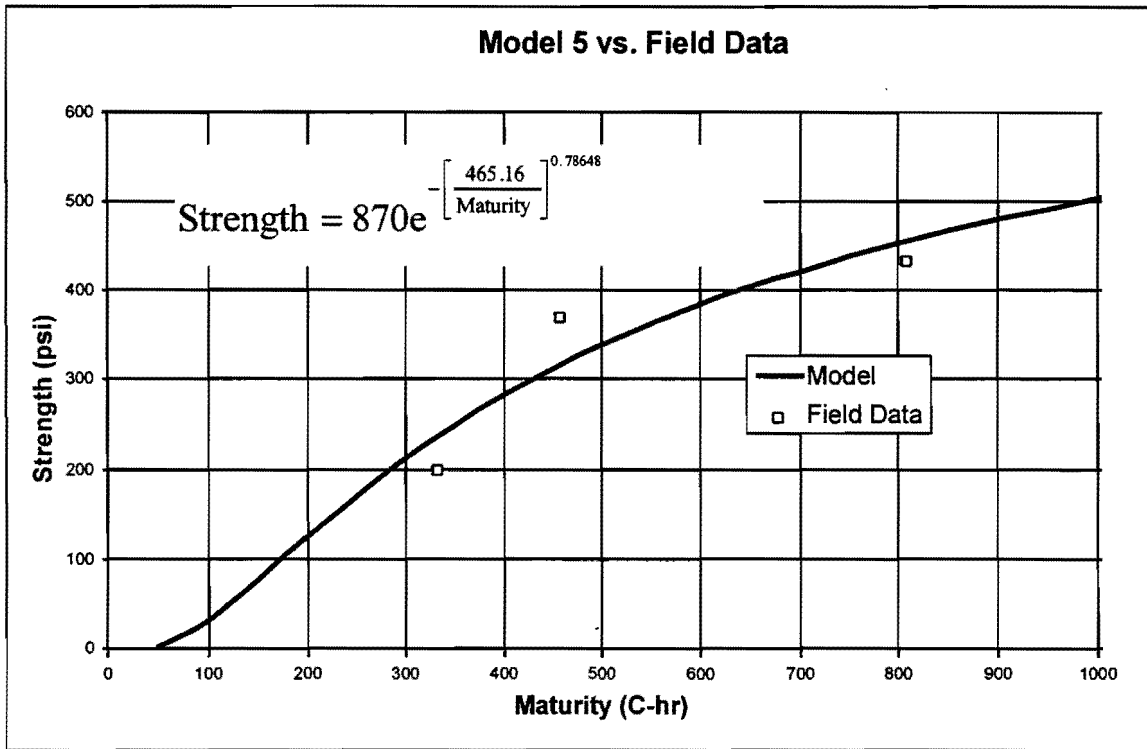

**Figure 14. Model 5 versus Test Results**

The regression analysis yielded a limiting strength of 870 psi. By using this value, the relative strength values were calculated. Then, the modified maturity strength equation (Equation 13-e) was utilized. Corresponding calculations are displayed in Table 12. The data points and the corresponding trend line were plotted in Figure 15.

**Table 12. Calculations for Field Data**

Maturity (°C-hr)	Strength (psi)	Relative Strength S/Sult	Ln (Maturity)	Ln (-Ln(S/Sult))
332	200	0.229885	5.805135	0.385382
457	370	0.425287	6.124683	-0.15667
808	434	0.498851	6.694562	-0.3632

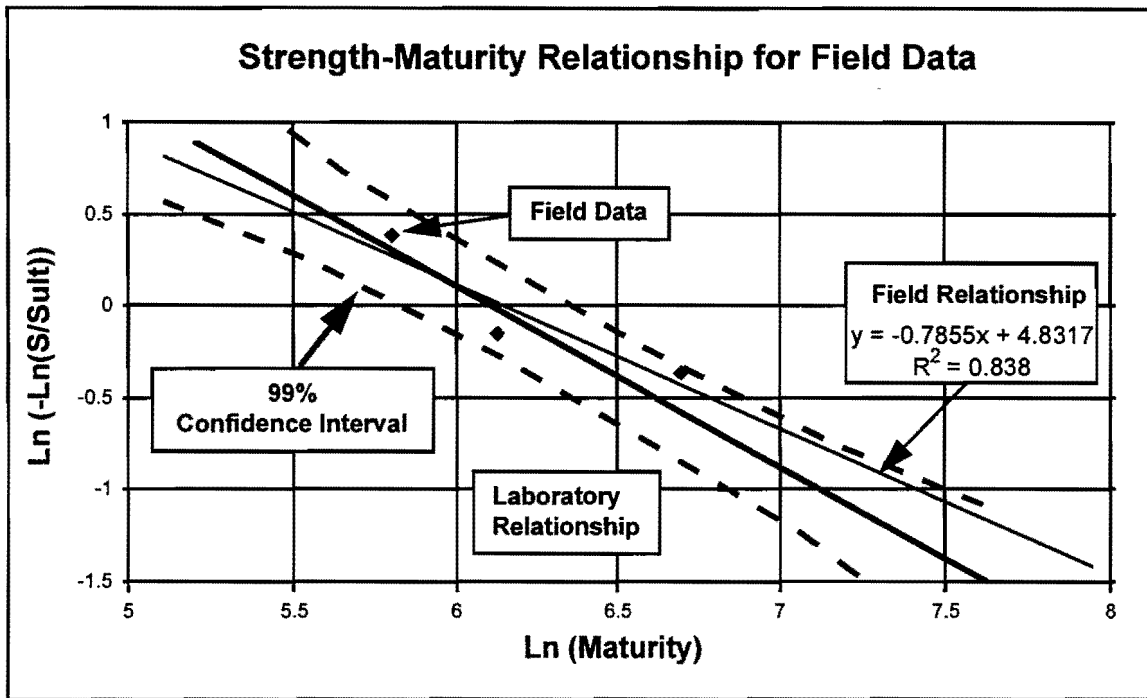

Figure 15. Strength-Maturity Relationship for Field Cured Beams

The linear regression analysis from the field beam breaks and from the laboratory tests are compared in Table 13.

Table 13. Comparison of the Field and Laboratory Results

Parameter	Laboratory	Field
$\beta_0$ : Intercept	-1.03034	-0.7855
$\beta_1$ : Slope	6.33932	4.8317
$R^2$ : Coefficient of Determination	0.9827	0.838

A statistical test was carried out in order to check whether the strength-maturity relationship is unique and independent of curing temperature for a given mixture proportions or not. This statistical test determines whether it is reasonable to conclude that the laboratory strength-maturity equation is different from the field strength-maturity equation. The statistical tests for evaluating the variation of the intercept and slope values for field and laboratory tests are shown in Appendix G.

As a result of these analysis, it was found that the slope and intercept values obtained by field data analysis were within the 99% confidence interval of the values obtained by laboratory analysis. Likewise, the slope and intercept values obtained by laboratory analysis were within the 99% confidence interval of the values obtained by field analysis.

In both results, the hypothesis that these two equations are the same equation with a 99% confidence limit could not be rejected. This conclusion again supports the hypothesis that the relationship between the double logarithm of the relative strength and logarithm of the maturity is independent of curing temperature and unique for the same mixture proportions. Moreover, this concludes that a laboratory strength-maturity relationship can be used at the field. The opening maturity value was calculated by using this relationship. Corresponding calculations are presented in Table 14.

**Table 14. Opening Maturity Calculations**

<b>Opening Str.</b> <b>S<sub>open</sub> (psi)</b>	<b>Relative Str.</b> <b>S<sub>open</sub>/S<sub>ult</sub></b>	<b>Ln (-Ln(S<sub>open</sub>/S<sub>ult</sub>))</b>	<b>Ln (Mat<sub>open</sub>)</b>	<b>Mat<sub>open</sub></b> <b>(°C-hr)</b>
425	0.4885	-0.33351	-6.47634	649

After validating the laboratory strength-maturity relationship, the opening maturity can also be calculated by using a simplified approach. Only one field beam break would be sufficient to calculate the opening maturity value. This method is referred as “one beam method”. The opening maturity is calculated for the 3rd placement of the Chasewood Parkway Construction Project. One beam method is explained in the following paragraphs.

The first step is to find the limiting strength by using the strength-maturity relationship. This procedure is called the calibration of the strength-maturity curve. The maturity and strength of a single beam break was used as a starting point. The natural logarithm of the maturity value was calculated. The strength-maturity relationship is a linear relationship between the natural logarithm of the maturity and the double log of the relative strength value. By using the natural logarithm of the maturity value and the

linear relationship, the double logarithm of the relative strength is calculated. Then, appropriate mathematical operations can be carried out to calculate the relative strength. Since, the strength of the beam at that maturity value is known, the limiting strength value is calculated by dividing this strength value by the relative strength.

The next step is to calculate the relative strength value for the opening strength. The calculation of the limiting strength is explained in the previous paragraph. This limiting value is used to calculate the relative strength for opening criteria by dividing the opening strength criteria by the limiting strength. Once the relative strength value for the opening criteria is calculated, the opening maturity is calculated by using the strength-maturity relationship.

The corresponding opening maturity of the 3rd placement calculations are displayed in Table 15. The method for the calculation of the opening maturity is graphically explained step by step in Figure 16.

**Table 15. Opening Maturity Calculations for the 3rd Placement**

<b>Maturity (°C-hr)</b>	539
<b>Ln (Maturity)</b>	6.2897
<b>Ln (-Ln(<math>S_{open}/S_{ult}</math>))</b>	-0.14123
<b><math>S/S_{ult}</math></b>	0.419667
<b>Strength (psi)</b>	610
<b><math>S_{ult}</math> (psi)</b>	1453.5
<b><math>S_{open}</math> (psi)</b>	425
<b><math>S_{open}/S_{ult}</math></b>	0.292391
<b>Ln (-Ln(<math>S_{open}/S_{ult}</math>))</b>	0.20674
<b>Ln (Mat<sub>open</sub>)</b>	5.951996
<b>Mat<sub>open</sub> (°C-hr)</b>	384.5201

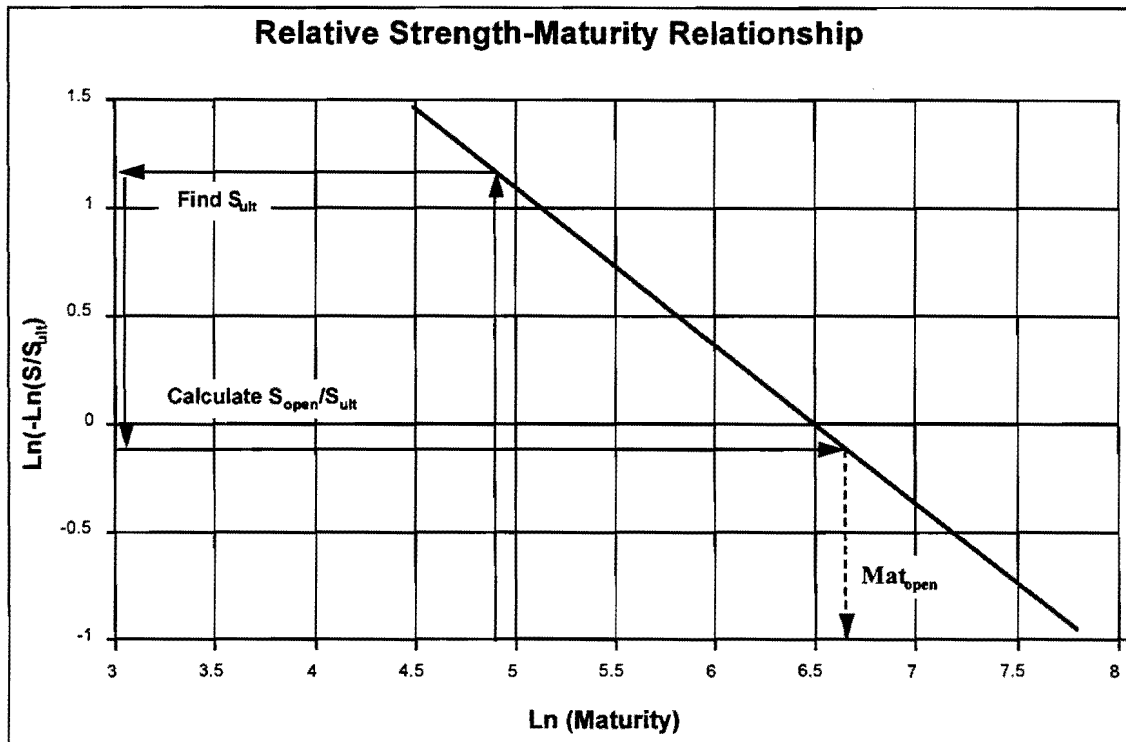

Figure 16. One Beam Method

## CONCRETE MATURITY-TIME SIMULATION

In previous sections, the relationship between strength and maturity was discussed. Different models were statistically tested and the best model to represent the laboratory data was chosen as a strength-maturity equation. Then it was shown that this equation can be used at the field as a strength-maturity relationship. Moreover, calculations were made to find the opening maturity. However, does predicting the opening maturity value solve the problem of not knowing how long curing period will be? The answer to this question is “no”. However, if it could be, a way would be provided where by a particular mixture could be qualified for a particular application.

The maturity method can be used to qualify the application of the concrete and it can be used to predict the strength of the concrete by monitoring its maturity if the ultimate strength is known. However, the maturity method can not be used to estimate how long the curing will take place. It is the “opening maturity” not the “opening time” that can be predicted by using the maturity method. In order to qualify a mixture, relative

to the opening time, the time when the maturity of the concrete will meet the opening maturity value needs to be estimated.

As explained earlier, maturity is a function of time and concrete temperature. The temperature history of the concrete is used to calculate the maturity. Likewise, in order to predict opening time, temperature-time relationship of concrete needs to be known.

The temperature of the concrete depends on several factors. First of all, as discussed earlier, the exothermic chemical reactions that take place during the hardening of concrete generate heat. The amount of heat generated during this phase depends on factors, such as the amount of cement in the concrete, cement type, water cement ratio, and activation energy of cement. Secondly, the temperature of the environment has an impact on the actual concrete temperature. Amount of solar radiation, wind speed, and air temperature affect the concrete temperature. Finally, the curing method influences the temperature of the concrete. Curing methods provide insulation for the concrete such that it will not lose the generated heat rapidly.

The process of heat development in a concrete pavement can be simulated by utilizing mathematical relationships among all the factors that affect the concrete temperature and finite element method. These factors and their effects on the temperature can be used to model the heat development process of a concrete slab. The physical rules of heat transmission and transfer can be utilized to calculate the concrete temperature.

In 1996, Yang (26) developed a concrete temperature simulation computer program. The program utilizes the factors that affect the concrete temperature as an input, and calculates the temperature of the concrete slab at certain time intervals. Basically, this program utilizes the mathematical relationships among the inputs and finite element method to simulate the heat development process of the concrete slab. Equation 14 shows the unsteady state energy balance equation used in this program.

$$\frac{\partial}{\partial x} \left( k_x \frac{\partial T}{\partial x} \right) + \frac{\partial}{\partial y} \left( k_y \frac{\partial T}{\partial y} \right) + Q_h(t, T) = \rho c_p \frac{\partial T}{\partial t} \quad (14)$$

Where,

- $k_x, k_y$  = thermal conductivities of concrete (W/m °C),
- $\rho$  = concrete density (kg/m<sup>3</sup>),
- $c_p$  = specific heat (J/kg °C), and
- $Q_h$  = generated heat from heat of hydration of cement and external sources (W/m<sup>3</sup>).

This computer program can be used to estimate concrete temperature at certain time intervals under given conditions. Thus, the maturity values can be calculated by using this temperature-time data. Moreover, when the opening maturity value is known, the simulation results can be used to calculate the opening time.

In order to calculate the estimated temperatures for the field, environmental and material related inputs should be entered into the simulation program. These input variables are:

- 1) Cement type (I, II, or III),
- 2) Cement content per cubic yard of concrete,
- 3) Water-cement ratio,
- 4) Maximum air temperature,
- 5) Minimum air temperature,
- 6) Overcast condition (sunny, partly cloudy, or cloudy),
- 7) Curing method (five options available),
- 8) Start time of paving,
- 9) Initial concrete temperature,
- 10) Opening criteria (time when the curing materials will be removed), and
- 11) Pavement thickness.

This program was used to simulate the concrete temperature. The appropriate input values were entered and the estimated temperature values were obtained from the computer output. The results of this simulation will be discussed in the following sections.

## Opening Time Prediction

The limiting strength and opening maturity values were calculated for the placements, as explained in the previous chapter. Also the input values for the placements were entered. The simulation program calculated the concrete temperature values of the placements at one hour time intervals. By using these temperature values, the maturity values were calculated. As a result, besides the strength-maturity relationship, the maturity-time relationship was also predicted. Calculation of the opening maturity was discussed in the previous chapter. By using the maturity-time relationship obtained from the computer simulation, the opening time can be estimated or predicted.

The maturity-time relationship is shown on the same chart as the strength - maturity relationship. The relationship between strength, maturity, and time are presented in Figure 17.

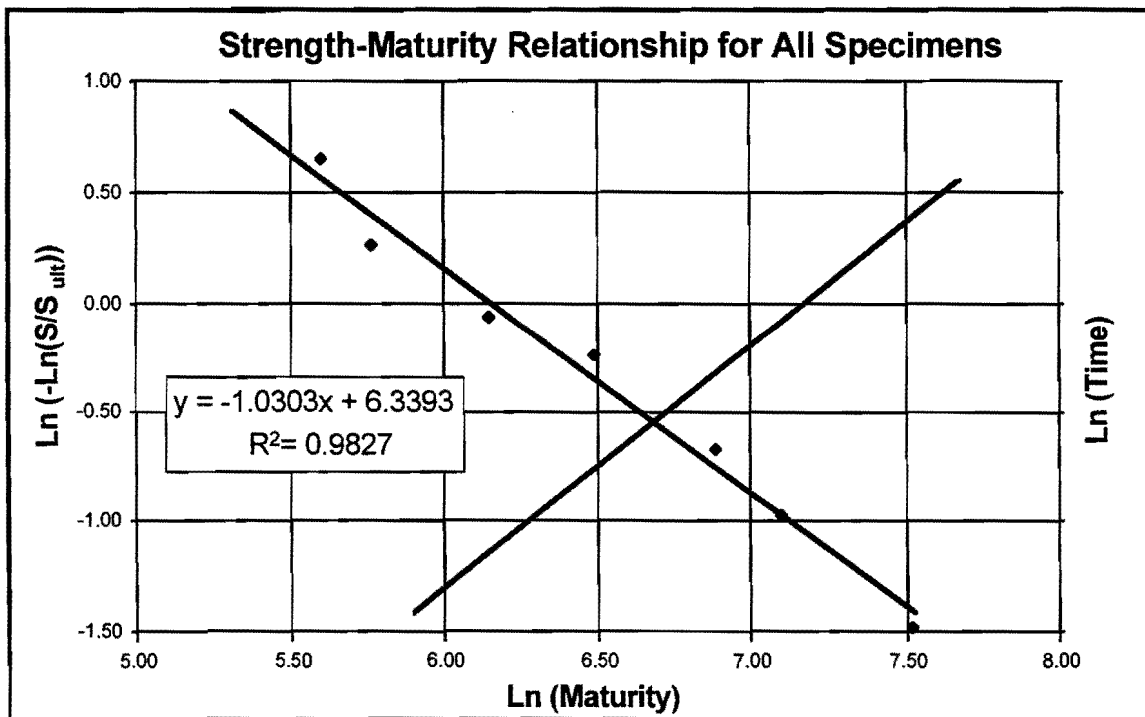

Figure 17. Maturity, Strength, Time Relationship for Field Conditions



## Validation

The actual field limiting strength, opening maturity and opening time data that was collected during the construction of Chasewood Park Intersection was compared to the values estimated by the program. The predicted values and actual values are presented in Table 16.

**Table 16. Comparison**

<b>Date</b>	<b>Actual Opening Time</b>	<b>Computer Predicted Opening Time</b>
<b>03/16/1996</b>	16:00	15:57
<b>03/17/1997</b>	8:30	9:16

Predicted and actual temperature-time graphs are compared to each other. The results are shown in Figure 18 for placements 1, 2, and 4, and in Figure 19 for placement 3. Corresponding temperature and time values are presented on Table H-1, in Appendix H for placements 1, 2, and 4, and on Table H-2 in Appendix H for placement 3.

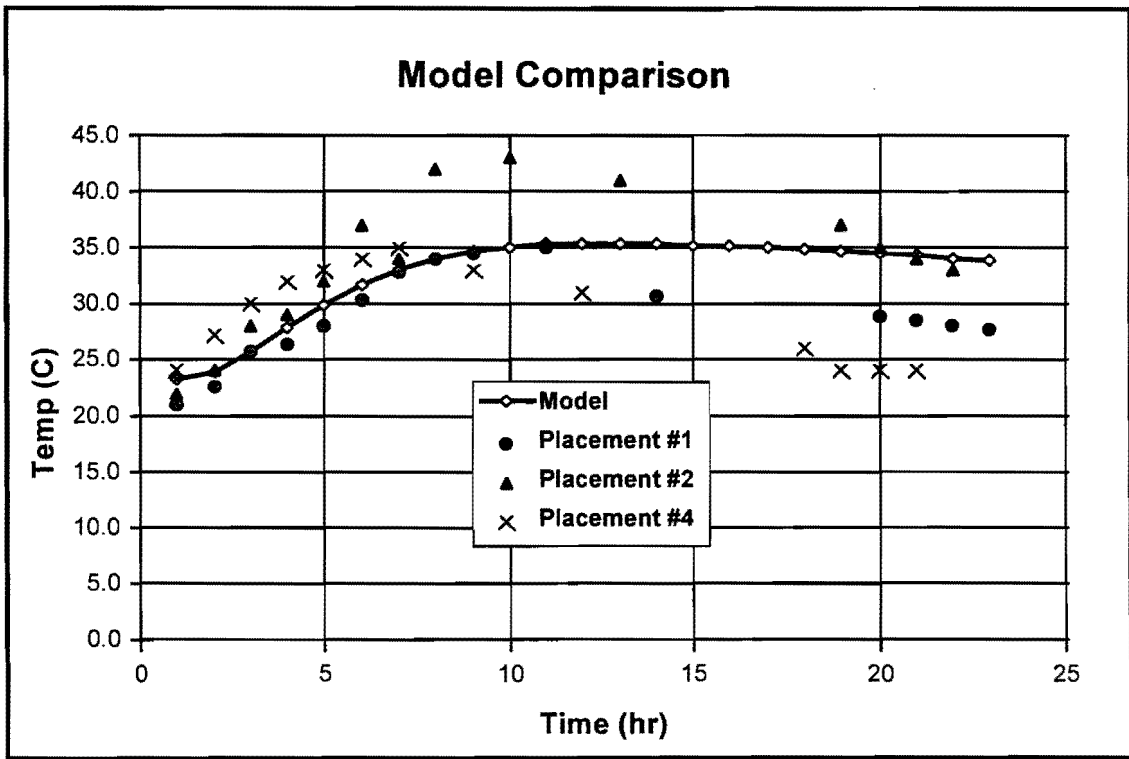

Figure 18. Comparison of the Model to March 16, 1996 Data

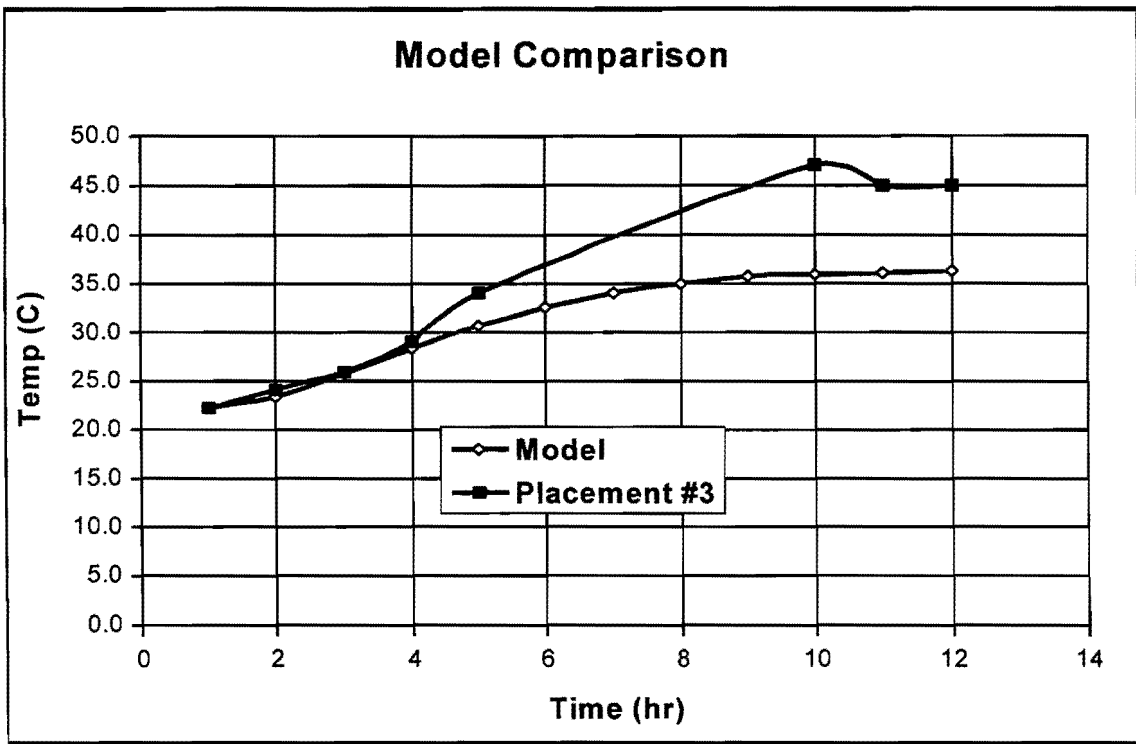

Figure 19. Comparison of the Model to March 17, 1996 Data

As seen from the table and the charts, the opening time values predicted by the computer program were reasonably close to the actual opening times. The actual field data may vary from the predicted values for several reasons:

1. For the heat flow calculations, the computer utilized an approximate value of activation energy instead of the actual activation energy value. The activation energy value was approximated by using the cement type and w/c ratio data. When the actual value of activation energy is used for the given mixture proportions, the heat flow process can be simulated more accurately.

2. Material Imperfections. Materials that were used for the laboratory tests and for the construction might differ in some manner. This might yield a slight difference between the calculated values and the actual values.

3. Weather conditions might vary. The simulation program assumes a smooth change of temperature throughout the day. However, the air temperature might change considerably faster especially during windy and cloudy days.

4. The data obtained from the field calibration beams may not be reliable. For example, there was a huge difference between the predicted and actual data on March 17 placement, when compared to March 16 placement. The variability decreases when more beam breaks are used to calibrate the maturity-strength curve.

In summary, computer simulation of concrete temperature development and its use on predicting the opening time were discussed. The simulation program was used to estimate the concrete temperature values for given mixture designs and weather conditions. Then, these temperature values were used to calculate the maturity of the concrete. The opening time was calculated by using the opening maturity value. The opening time estimated by using the simulation program was compared to the actual opening time. As a conclusion, it was shown that the simulation program calculated the opening time reasonable close to the actual value.

## CONCLUSIONS

Upon completing the work with the Chasewood intersection, the research team considered what efforts were essential to the contractor interaction phase and the construction phase of the project. Looking at what work was important, and what was not, the team formulated the steps that make up each of the final two phases of the 72 hour intersection reconstruction process. The main steps in the contractor interaction phase were to form the construction team, review the contractor plan, and qualify the mix design. These three steps proved to be the most important aspects of the contractor interaction phase. The Chasewood Park Drive project confirmed the need for a team approach because intensive planning was required to ensure all aspects of the reconstruction effort were considered. Also, the contractor's plan for reconstructing the intersection may be different than the design documents indicate. The contractor's plan must be fully understood and accepted by all participants in the process. The mix design must be understood so the contractor can achieve the flexural strength needed to open the intersection for traffic or to drive on completed segments of the intersection during construction.

The construction phase of the process was comprised of two main steps: monitor construction operations and materials management. These two steps provided TxDOT with activities to perform during the actual construction of an intersection. Monitoring construction operations through collecting data and information is vital when applying the 72 hour intersection reconstruction process on future projects. Construction related information from the Chasewood Park Drive project was used, for example, to evaluate the Red Bluff project for possible completion of that intersection in 60 hours. Monitoring the maturity of concrete during construction provides an effective means of evaluating actual flexural strength achieved for opening.

## **PROCESS MODEL FORMALIZATION**

### **INTRODUCTION**

Once the construction and material concepts have been successfully applied and validated, the next step in the research process was to formalize the process model that would describe the actions taken throughout the research project. This model would supply TxDOT with a framework of activities that could be followed when the 72 hour intersection reconstruction process was implemented.

### **MODELING APPROACH**

In order to formulate the 72 hour intersection reconstruction process effectively, a modeling technique was required that permitted the design and layout of the process. This technique had to have the ability to capture functions (activities or steps) and key information supporting the performance of these functions. Finally, modeling relationships between different functions, as well as project phases, was a key requirement of the technique.

Based on these criteria, IDEF0 function modeling was selected to develop and illustrate the 72 hour intersection reconstruction process. This technique formalizes a process by identifying primary functions and representing them in a structured procedural form. IDEF0 uses Cell Modeling Graphic Representation as shown in Figure 20 (27).

Figure 20 shows a function (the box) and the interfaces to or from the function as arrows entering or leaving the box. The input, information needed to perform the function, is transformed by the function to provide outputs, information produced by the function. Controls, arrows coming into the top of the function box, are information that governs the accomplishment of the function. Mechanisms, arrows entering the bottom of the function box, are people or tools that help perform the function. Functions are described by short verb phrases. Inputs, outputs, controls, and mechanisms are described by noun phrases. For example, perform constructability analysis, is a function. Input for

this function might be a construction method and traffic control plan. An output of this function would be a recommendation as to the constructability of an intersection. A mechanism for the function performance could be a construction engineer or a design team. Finally, a control could be the constructability procedures that determine the detail of the analysis.

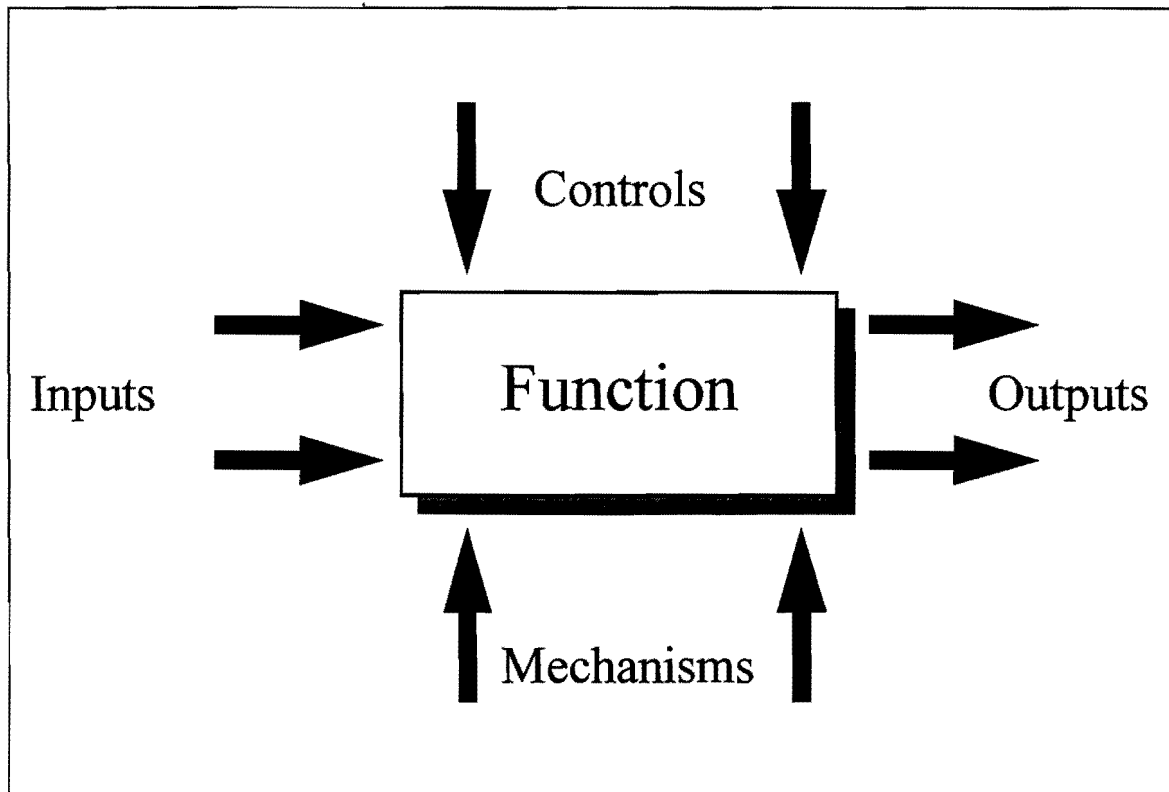

**Figure 20. Cell Modeling Technique**

In IDEF0 modeling, the process is represented at the first level by one general box called the context diagram. The context diagram represents the whole system as a simple unit-box with arrow interfaces to functions outside the system. Since the single box represents the system as a whole, the descriptive name written in the box is general. This general box is then decomposed (broken down) into subprocesses or functions with further details and more interface arrows between functions as illustrated in Figure 21. Each successive level of the diagram becomes increasingly specific.

IDEF0 modeling is hierarchical in nature, that is, lower level diagrams are decompositions of the upper level diagrams immediately preceding them (Figure 21). IDEF0 uses a specific numbering scheme to enable the viewer to see this hierarchy in the process model. A0 is the context or summary diagram. A0 is decomposed into sub-functions A1, A2, A3, etc. The decomposition continues until the desired level of detail is reached. For example, A0 is decomposed into A1, A2, and A3. A1 is then decomposed into A11 and A12, A2 into A21 and A22, etc.

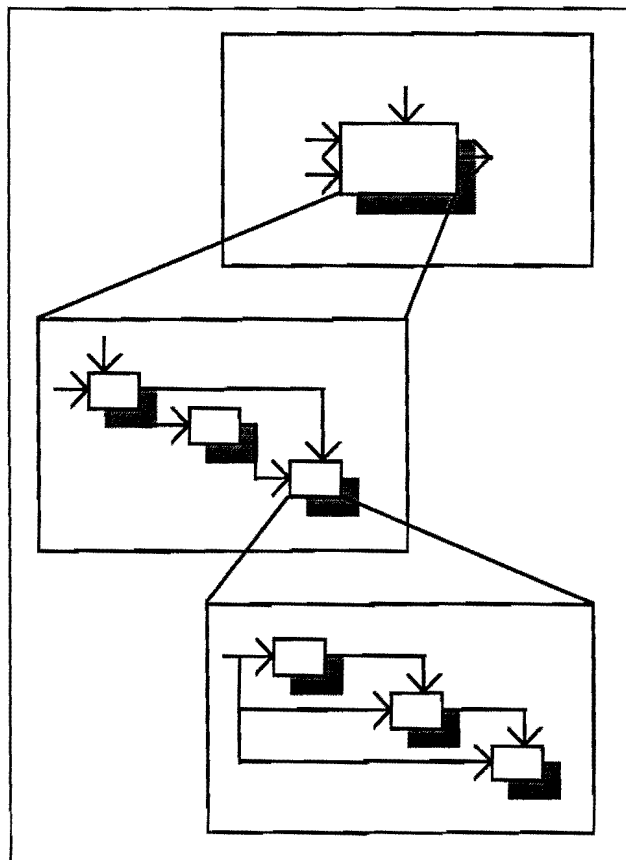

**Figure 21. IDEF0 Model Structure**

In the case of the 72 hour intersection reconstruction process, the first level, or context diagram is “Reconstruct Intersection Using 72 Hour Reconstruction Process.” The next level is more specific and is broken into four main functions: Perform Intersection Planning, Design Intersection, Interact with Contractor, and Construct

Intersection. The third level of the process further decomposes each of the 2nd level functions into specific sub-phases that occur during each of these major project development phases.

### **72 Hour Intersection Reconstruction Process Model**

The actual 72 Hour Intersection Reconstruction Process Model developed is shown in Figures 22 and 23. Figure 22 shows the general function described as “Reconstruct Intersection Using 72 Hour Reconstruction Process.” The function box at this level is the context diagram. The function box has inputs, outputs, controls, and mechanisms. The inputs (arrows entering the left side of the box) to the function box include traffic data, intersection characteristics, intersection type, resources, local businesses, and utility locations. These inputs are transformed into the outputs (arrows leaving the right side of the box) also displayed in Figure 22. These outputs are: plans and specifications, contract language, historical data, construction using the traditional approach, and the reconstructed intersection itself. Three main mechanisms (arrows entering the bottom of the box) are utilized to perform the transformation of the inputs into the outputs. These mechanisms are the design and construction teams, TxDOT decision-makers (management), and resources and tools. The final arrows, entering the function box from the top, are the controls that govern the 72 hour intersection reconstruction process. These controls are: the location of the intersection, project execution procedures, information, budget and time constraints, quality control and quality assurance guidelines, and resource availability.



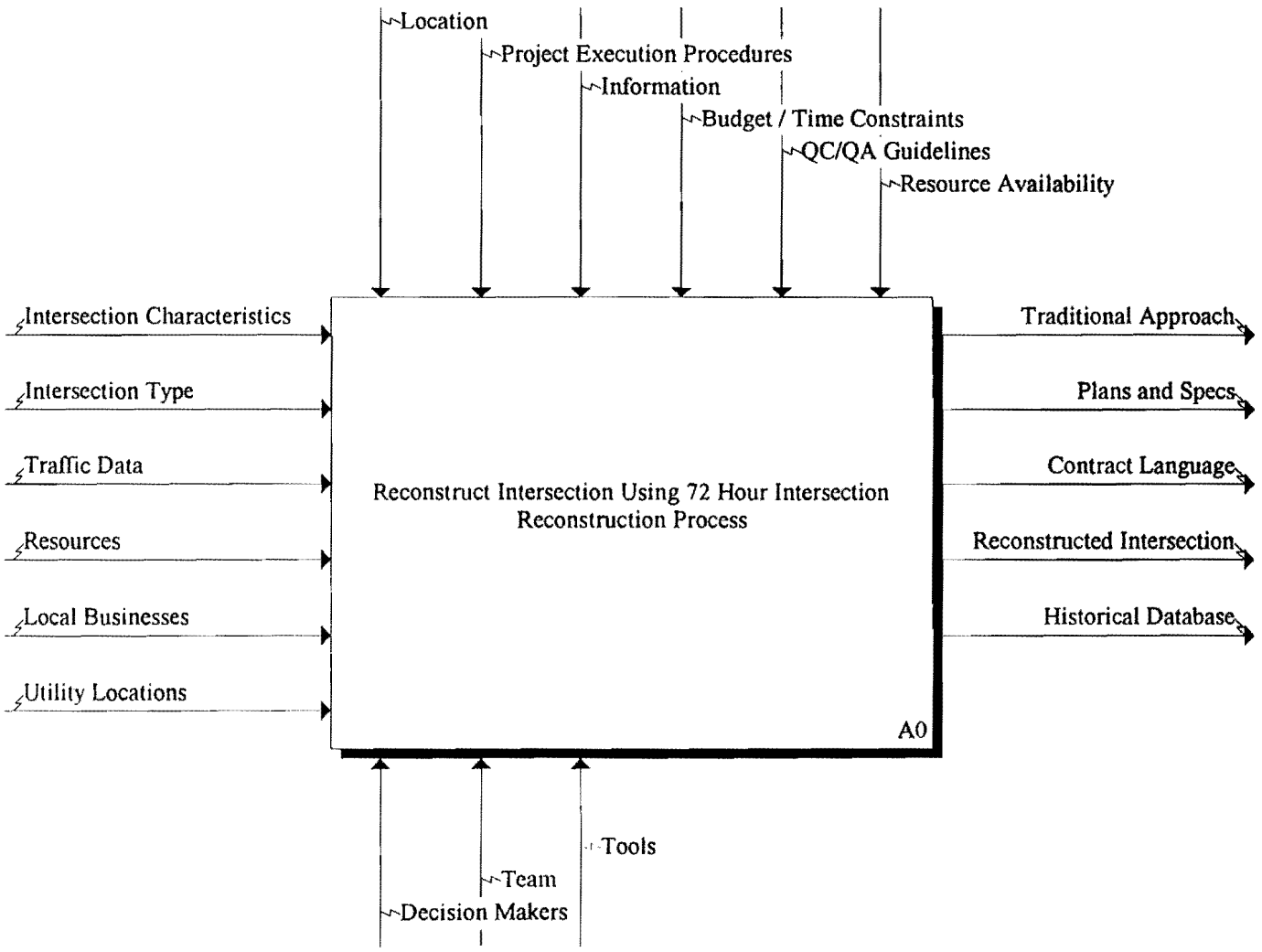

Figure 22. Context Diagram for 72 Hours Intersection Reconstruction Process

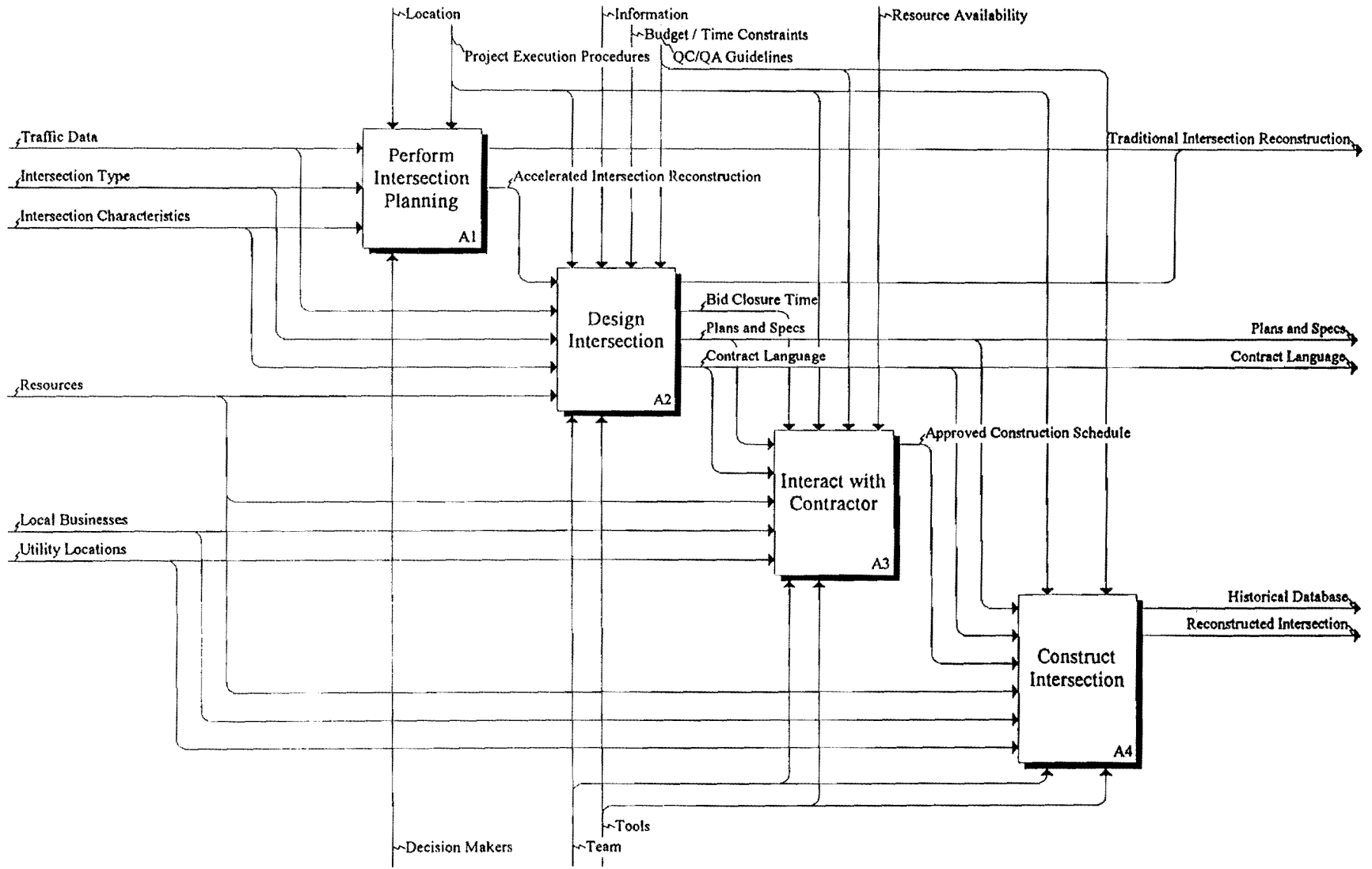

Figure 23. First Decomposition of Context Diagram

The first decomposition of the context diagram is displayed in Figure 23. This level of the 72 Hour Intersection Reconstruction Process is made up of four function boxes. These four boxes represent the four components of the reconstruction process: Perform Intersection Planning, Design Intersection, Interact with Contractor, and Reconstruct Intersection. Each function box has inputs, outputs, mechanisms, and controls. In many cases, functions share these inputs, outputs, mechanisms, and controls. In other situations, outputs from one function will be inputs for a succeeding function.

The first component of the 72 Hour Intersection Reconstruction Process is to perform the intersection planning (Box A1). The main purpose of the intersection planning component is to eliminate intersections that clearly are not suited for the 72 hour intersection reconstruction process. By eliminating the intersections early in the process, the design team avoids unnecessary work. This component of the process is further decomposed into two steps: Form Design Team and Pre-Evaluate Intersection.

The second component of the process, Design Intersection (A2), is displayed in Figure 23. During this component, the intersection is designed, contract documents are compiled and the project is let. This component of the project is further decomposed into four steps: Develop Preliminary Design Data, Perform Constructability Analysis, Evaluate Intersection, and Finalize Design Documents.

The third component of the process is to interact with the contractor (A3). During this component, work focuses on reviewing any changes to the design and methods established in the design component of the process. Mix design qualification also begins during this component. The decomposition of the Interact with the Contractor function is made up of three steps: Form Construction Team, Review Contractor Plan, and Qualify Mix Design.

The final component of the 72 hour intersection reconstruction process is Reconstruct Intersection (A4). During this component, the intersection is reconstructed. This component is primarily designed to allow TxDOT to monitor the construction operations and obtain data for future use in the 72 hour process. The decomposition of Reconstruct Intersection is comprised of two steps: Monitor Construction Operations and Manage Material.

## 72 HOUR INTERSECTION RECONSTRUCTION PROCESS GUIDELINES

The third level of the process model contains the steps that make up the four components of the 72 hour process. These steps are, in essence, the guidelines that TxDOT must follow when implementing the 72 hour process. Each step is a function box that has inputs, outputs, mechanisms, and controls. Appendix I contains the 72 hour intersection reconstruction guidelines. The guidelines are intended to describe the decomposition of the graphical representation of the process model shown in Figure 23. Each step in the guideline is set up with eight divisions. These divisions are: Who, Objective, Actions, Information Needed, Issues to Consider, Constraints, Resources and Tools, and Outputs. These divisions are basically the arrows that are attached to a function box (inputs, outputs, mechanisms, and controls).

The inputs are real objects or data needed to perform a step. These objects or data are then transformed by the function into the output. The inputs are described in the *Information Needed* division of each step in the guidelines. The outputs of each step are objects or data produced as a result of performing the step. These outputs are identified in the guidelines under the same title, *Outputs*. The mechanisms for each step describe the person or device, which carries out the step or the means by which the function is performed. Two divisions, *Who* and *Resources and Tools*, identify the mechanisms that are associated with each step. The controls for each step are those items that govern the accomplishment of the step, or factors that influence or determine the outputs. These are specified in the *Issues to Consider* and *Constraints* division of each step. The two remaining divisions that are addressed in each step of the guidelines are Objectives and Actions. The *Objective* section outlines the step and identifies the problems to solve. The *Actions* division is a itemized list of each task that must be performed in order to complete the step. Table 17 shows a comparison of IDEF0 modeling terminology and the 72 hour guideline terminology.

**Table 17. Comparison of IDEF0 and Guidelines Terminology**

<b>IDEF0</b>	<b>Guideline</b>	<b>Example</b>
Inputs	Information Needed	Traffic Data
Mechanisms	Who and Resources and Tools	Design Team / TxDOT Procedures
Controls	Issues to Consider and Constraints	Budget / Time
Functions	Actions	Evaluate Sequence of Construction
Outputs	Outputs	Construction Phasing Plan

The 72 hour intersection reconstruction guideline steps are set up to provide the person performing the task with the direction needed to successfully complete each step. Example outputs of each step are contained in different appendices to this report. The guidelines are by no means “all the information needed” to perform each step. These guidelines are merely a structure of events to follow and ideas that will allow an engineer to produce the desired results.



## CONCLUSIONS AND RECOMMENDATIONS

### CONCLUSIONS

The following two sections discuss the conclusions in relation to intersection planning and methods and the intersection reconstruction implementation.

#### Planning and Methods

- Extensive preplanning prior to construction is essential and should include:
  - Detailed schedule of activities on an hour-by-hour basis,
  - Check utility locations and make necessary adjustments prior to construction,
  - Work with local businesses to ensure coordination and cooperation in closing the intersection especially where entrances to businesses are impacted,
  - Ensure that material is ordered and available when ready to close the intersection,
  - Ensure construction equipment is available and ready to start as soon as the intersection is closed. Every hour is important. Also, backup equipment should be available in case of a breakdown, and
  - Ensure batch plant is available when needed. Plan pour times and quantities for each pour. Ensure proper mix design is used.
- Involve contractor management, crew supervisors, batch plant operator, and TxDOT field engineers and inspectors in preconstruction planning process.
- Overall construction sequencing requires concurrent activities. Stage crews so they work in sequence but concurrently in different areas of the intersection. Further, as much concrete as possibly should be poured at one time.
- Demolition, excavation, and removal of existing material is critical. Contractor must use the right equipment. The ball and crane operation was not as

effective as the Hercules Pavement Breaker. Equipment logistics for these operations should be planned to avoid congestion and permit formwork operations to start as early as possible.

- Direct pour concrete if feasible. Determine if concrete trucks can drive on subgrade and allow this to support direct pouring.
- Concrete was workable and easy to place with superplasticizer. TxDOT and contractor must monitor maturity to predict flexural strength of concrete.
- Construct curbs, gutters and other similar items either before or after weekend construction of main pavement areas.
- Collect actual construction related data for future planning and design purposes such as crew production rates, activity durations, curing times, sequencing approaches, construction methods and equipment used, and crew sizes.

### **Intersection Reconstruction Implementation**

- Very intense effort required by everyone involved in the project.
- Contingency plans are vital and should include:
  - Schedule with alternate weekends in case of inclement weather;
  - Backup equipment available in case of breakdowns;
  - Contact with utility company if emergency occurs;
  - Contact with local businesses if problems occur; and
  - Consider alternate batch plant arrangements in case of batch plant shutdown.
- Monitoring maturity of concrete critical to aid in predicting opening time to traffic, when construction equipment can drive on newly placed pavement, and when forms can be stripped, if construction joint is needed.
- Completed reconstruction of Chasewood Park Drive intersection in one weekend versus typical time of two to three months.
- Cost of intersection reconstruction is higher than standard construction practice for reconstructing an intersection.



- Accelerated intersection reconstruction has significant risks, however, detailed planning and risk management will help mitigate some of the risks.
- Chasewood Park Drive reconstruction went extremely well, with very satisfied project participants.
- COMPAQ Computer was very pleased with outcome of project.

## **RECOMMENDATIONS**

Based on the observations discussed above, major recommendations for 72 hour urban highway intersection replacement are as follows:

- The first recommendation is to begin the intersection reconstruction process during the design phase. This enables the design to compliment and facilitate construction instead of complicating it. Construction expertise and knowledge must be consulted as plans and specifications are developed.
- The second recommendation is to incorporate accelerated intersection reconstruction into the plans, specifications, and contract language. By writing the intersection process into plans, specifications, and contracts, fees associated with a change in method will be eliminated, and a more competitive cost for reconstruction will result.
- A contingency plan should be developed to help mitigate the risks associated with this type of reconstruction.
- Because of the high intensity effort that 72 hour intersection reconstruction requires, only high payoff intersections should be selected.
- In order to better understand the complete process, a final recommendation is to construct a larger more complex intersection using the complete process and techniques developed in this research as a whole and not in pieces as was done in the development of the process.

Accelerated intersection reconstruction provides TxDOT with a unique opportunity to improve this aspect of their facility delivery process. Results from

applying concepts and techniques of 72 hour urban intersection replacement to the Chasewood Park Drive provide some evidence that implementation leads to:

- Reduced construction time,
- Fewer delays for motorists,
- Reduced impact on a local business, and
- Safer environment for motorists and construction personnel.

## REFERENCES

1. The Construction Industry Institute. "Schedule Reduction." Publication 41-1, April 1995.
2. The Construction Management Committee of the ASCE Construction Division. "Constructability and Constructability Programs: White Paper." *Journal of Construction Engineering and Management*, March 1991, Vol. 117, No. 1.
3. Anderson, S., Fisher D.J., and Gupta, V.K., "Total Constructability Management: A Process-Oriented Framework." *Project Management Journal*, Sept. 1995, Vol. XXVI, No. 3.
4. Anderson, S., and Fisher, D., "Constructibility Review Process for Transportation Facilities," NCHRP Report 360, Transportation Research Board, To be Published in 1997.
5. Anderson, S., and Fisher, D., "Constructibility Review Process for Transportation Facilities: Workbook," NCHRP Report 361, Transportation Research Board, To be Published in 1997.
6. The Construction Industry Institute. "Team Building: Improving Project Performance." Publication 37-1, July 1993.
7. Smith, G.L. and McWaters, B.R., (1995). "Partnering for Performance-Iowa's Experience with Design and Construction Enhancements for Quality Improvement of Concrete Pavements," Transportation Research Board, *Transportation Research Record*, No. 1478.
8. Flynn, L., (1992) "Partnering Invites Traffic Control Subs Into Fold," *Scranton Gillette Communications, Roads and Bridges*, Vol. 30, No. 7.
9. Javaiedi, M., Plummer, R., and Aber, M., "Incentives/Disincentives for Highway Construction Contracts," *Journal of Construction Engineering and Management*, ASCE, Vol. 121, No. 1, March 1995.
10. Herbsman, Z., Chen, W., and Epstein, W., "Time Is Money: Innovative Contracting Methods in Highway Construction," *Journal of Construction Engineering and Management*, ASCE, Vol. 121, No. 3, September 1995.
11. McIntosh, J.D., Electrical Curing of Concrete, *Magazine of Concrete Research* London, V. 1, No. 1, 1949, pp. 21-28.
12. Saul, A.G.A., Principles Underlying the Steam Curing of Concrete at Atmospheric Pressure, *Magazine of Concrete Research*, London, V. 2, No. 6, 1951, pp. 127-140.

13. Nurse, R.W., Steam Curing of Concrete, Magazine of Concrete Research, London, V. 1, No. 2, 1949, pp. 79-88.
14. Plowman, S.G., Maturity and the Strength of Concrete, Magazine of Concrete Research, London, V. 8, No. 22, 1956, pp. 13-22.
15. Bergstrom, S.G., Curing Temperature, Age and Strength of Concrete, Magazine of Concrete Research, London, V. 6, No. 19, 1953, pp. 61-66.
16. Freisleben, Hansen, P., Pedersen, J., Maturity Computer for Controlled Curing and Hardening of Concrete, Nordisk Betong, Stockholm, 1977, pp. 464-470.
17. Carino, N.J., Temperature Effects on the Strength-Maturity Relation of Mortar, Report No. 81-2244, National Bureau of Standards, Washington, D. C., 1981, pp. 99-105.
18. Nykanen, A., Hardening of Concrete at Different Temperatures, Especially Below the Freezing Point, Proceedings, RILEM Symposium on Winter Concreting, Danish Institute for Building Research, Copenhagen, 1956.
19. Kee, C.F., Relation Between Strength and Maturity of Concrete, ACI Journal, Proceedings, V. 68, No. 3, 1971, pp. 196-203.
20. Carino, N.J., Maturity Functions for Concrete, Proceedings, RILEM International Conference on Concrete at Early Ages, Ecole Nationale des Ponts et Chaussées, Paris, 1982, pp. 111-115.
21. Lew, H.S., and Reichard, T.W., Mechanical Properties of Concrete at Early Ages, Journal of American Concrete Institute, V. 75, No. 10, 1978, pp. 533.
22. Freisleben Hansen, P., Pedersen, J., Curing of Concrete Structures, CEB Information Bulletin, 1985, pp. 166.
23. ACI Manual of Concrete Practice, (1990), *Standard Practice for Curing Concrete (ACI 308-81)* Part 2, Construction Practices and Inspection Pavements.
24. Mindess, S., Young, J.F., (1981), Concrete, Curing pp. 302.
25. Kaleidagraph, Version 3.06, Synergy Software, 1996.
26. Yang, S., A Temperature Prediction Model in New Concrete Pavement and a New Test Method for Concrete Fracture Parameters, 1996, pp. 35.
27. Mayer, R., "IDEF0 Function Modeling: A Reconstruction of the Original Air Force Wright Aeronautical Laboratory Technical Report AFWAL-TR-81-4023, Knowledge Based Systems, Inc., 1992.

**APPENDIX A:**  
**WEST COLUMBIA PROJECT**



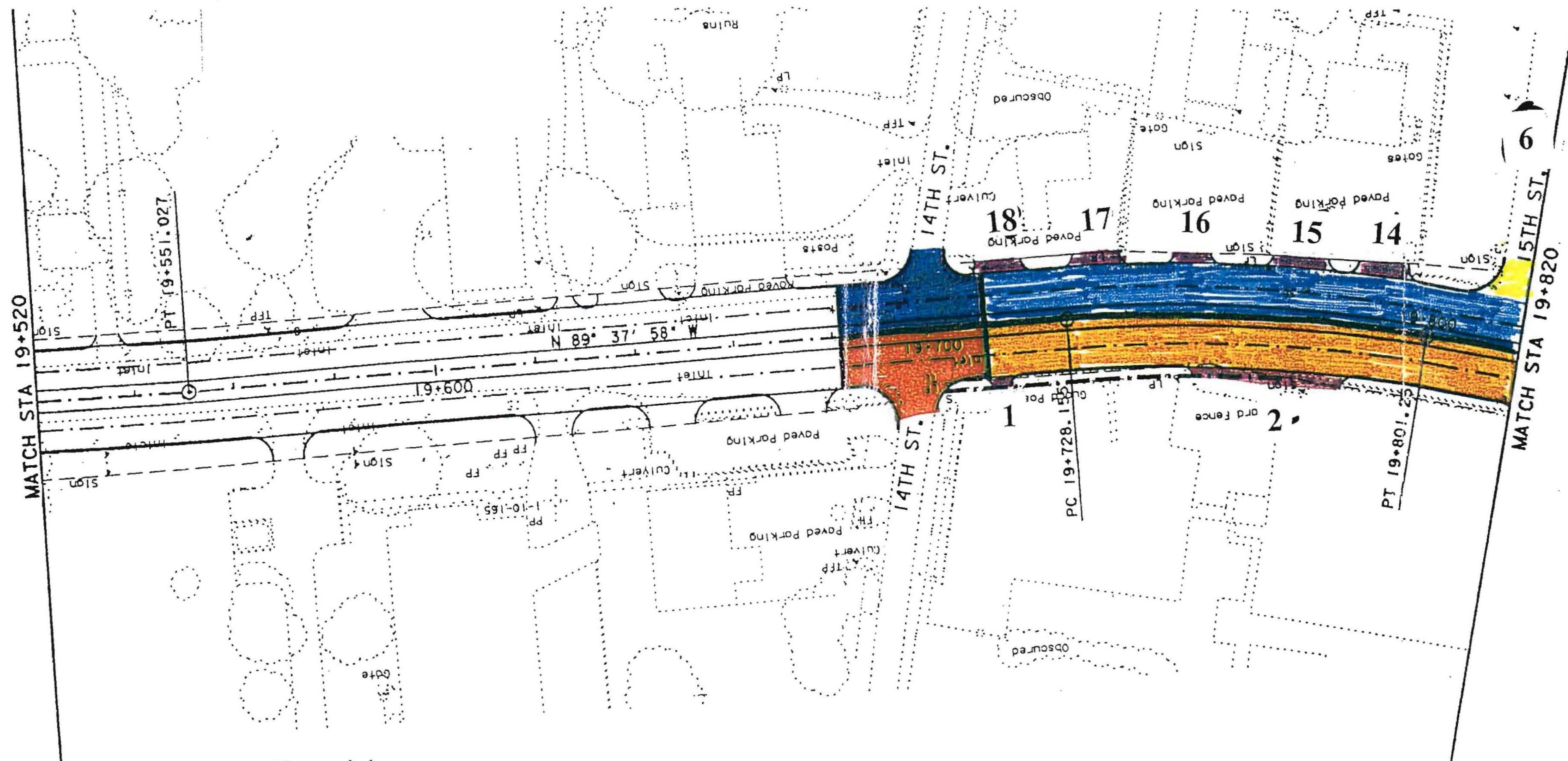







Figure A-1  
Downtown Phasing Plan for West  
Columbia (1 of 3)

- PI NUMBER     ▪ 46
- PI STATION    ▪ 19+764.895 (A)
- DELTA         ▪ 14° 23' 19.56" RT
- TANGENT      ▪ 36.741
- LENGTH      ▪ 73.095
- RADIUS       ▪ 291.063
- PC STATION   ▪ 19+728.155 (A)
- PT STATION   ▪ 19+801.25 (A)

SHEET TOTALS			
EST.	FINAL	UNIT	DESCRIPTION

	PHASE 1-A		PHASE 1+2 INTERSECTIONS
	PHASE 1-B		PHASE 1+2 DRIVEWAYS
	PHASE 2-A		
	PHASE 2-B		

**SH 35  
PLAN & PROFILE**

STA. 19+520 TO STA. 19+820

0 10 20 40 60

SCALE:  
PLAN 1:500  
PROFILE 1:50

SHEET 19 OF 45 SHEETS

 **TSC ENGINEERING COMPANY**  
ENGINEERS • SURVEYORS   HOUSTON, TEXAS

 Texas Department of Transportation

FED. NO.	FEDERAL AID PROJECT NO.	SHEET NO.	
6			
STATE	DIST.	COUNTY	
TEXAS	12	BRAZORIA	
CONT.	SECT.	JOB	HIGHWAY NO.
0179	02	068	SH 35

LEVELS DISPLAYED  
1 2 3 4 5 6 7 8 9 10 11 12 13 14 15 16  
ACC: 7/01/92 02:22:32 4/25/92 12:02:53 03/02  
5/30/93 05:30:04 04/24/94 44:24:34 44:54:14 48  
49:05:15 55:25:35 40:55:05 75:05:06 16:26:3



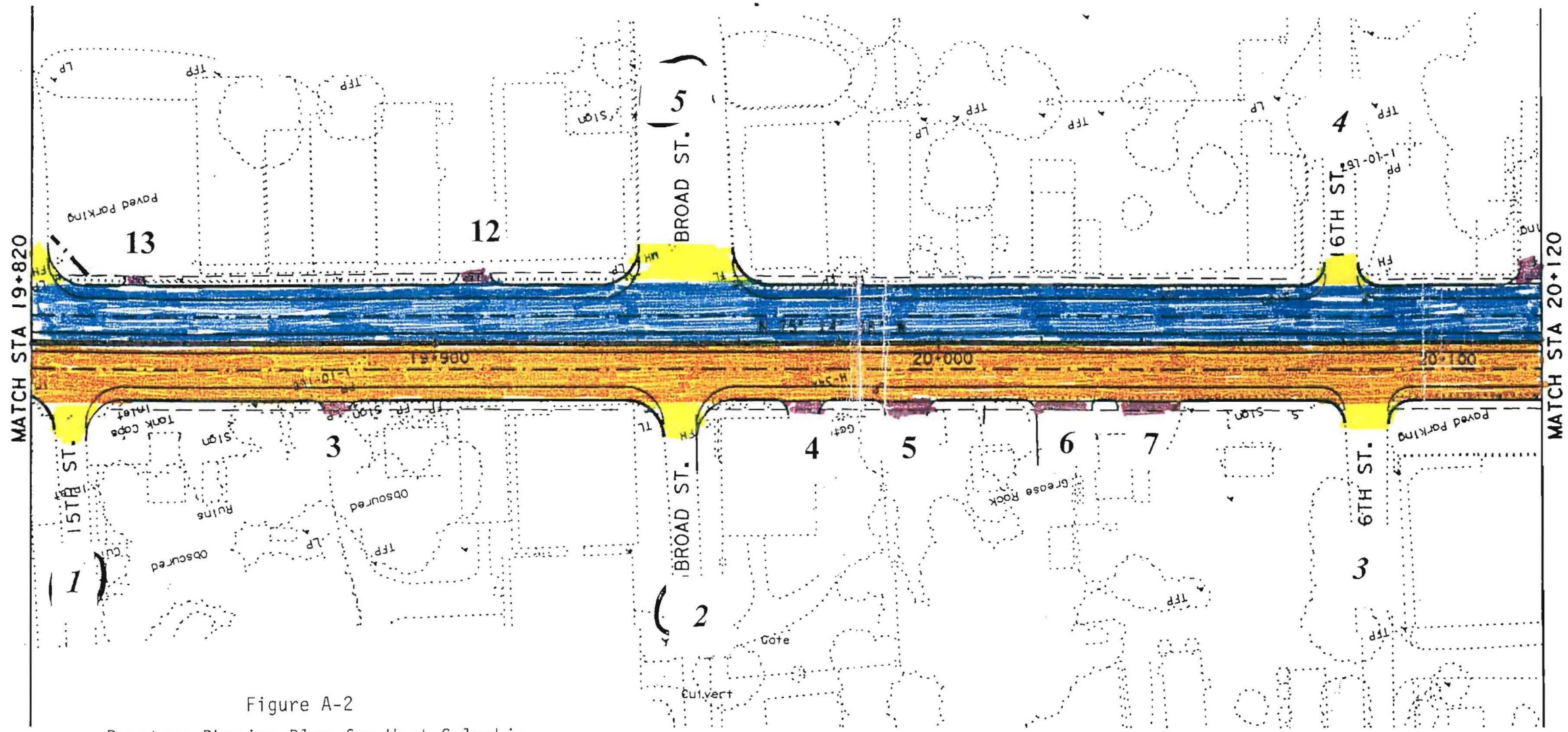

Figure A-2  
Downtown Phasing Plan for West Columbia  
(2 of 3)

LEVELS DISPLAYED  
1 2 3 4 5 6 7 8 9 10 11 12 13 14 15 16 17 18 19 20 21 22 23 24 25 26 27 28 29 30 31 32 33 34 35 36 37 38 39 40 41 42 43 44 45 46 47 48 49 50  
ACC\*  
FILE: S35RPP20.DGN

SHEET TOTALS			
EST.	FINAL	UNIT	DESCRIPTION

**SH 35  
PLAN & PROFILE**

STA. 19+820 TO STA. 20+120

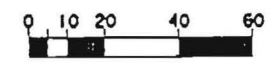

SCALE:  
PLAN 1:500  
PROFILE 1:50

SHEET 20 OF 45 SHEETS

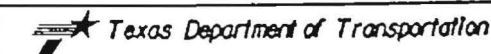
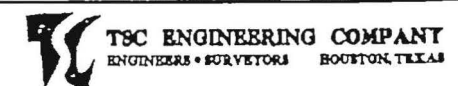

FED. RD. DIV. NO. 6	FEDERAL AID PROJECT NO.		SHEET NO.
STATE TEXAS	DIST. 12	COUNTY BRAZORIA	
CONT. 0179	SECT. 02	JOB 068	HIGHWAY NO. SH 35



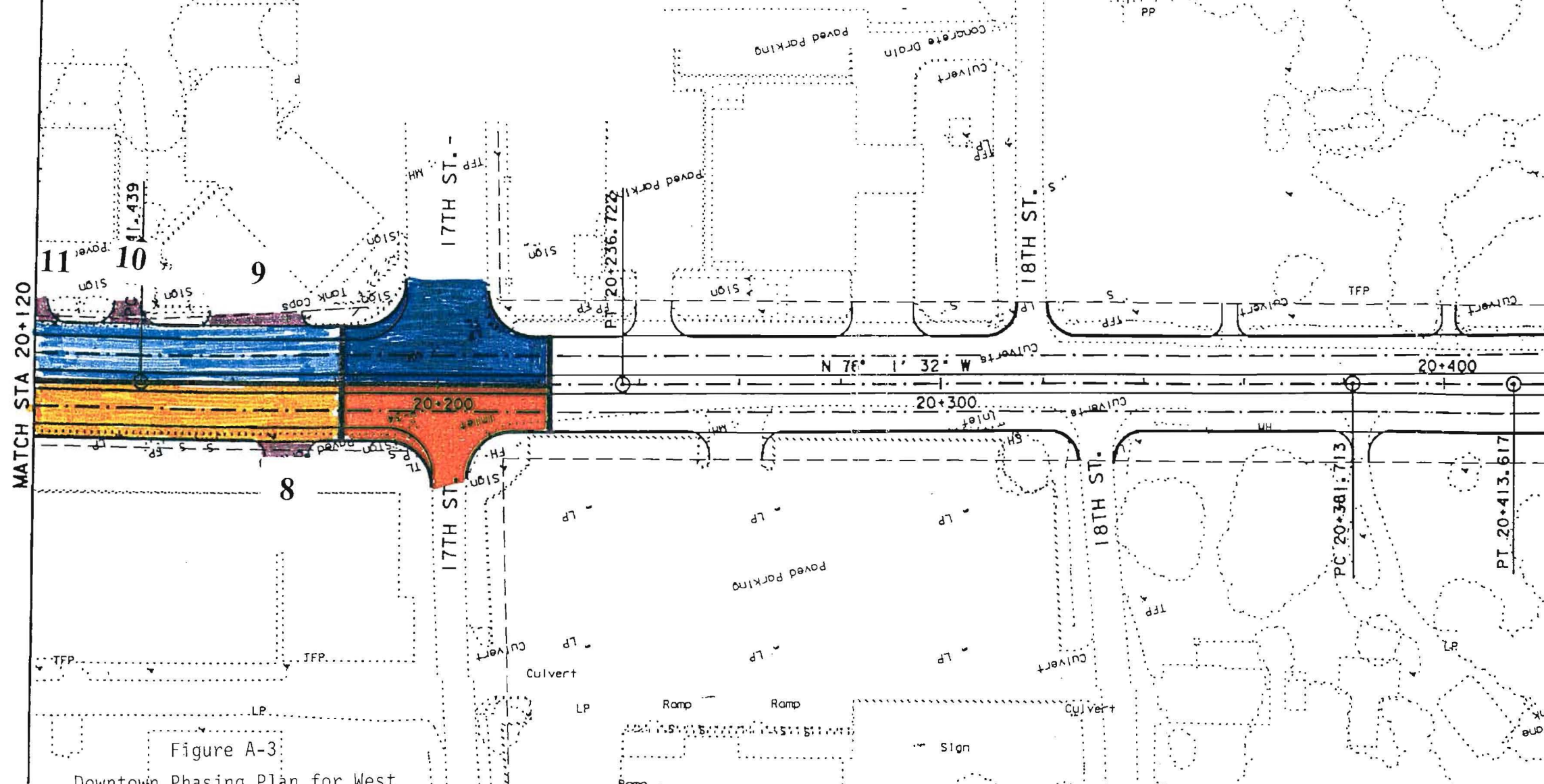

PI NUMBER	▪ 48
PI STATION	▪ 20+189.081 (A)
DELTA	▪ 0°46'53.46"LT
TANGENT	▪ 47.642
LENGTH	▪ 95.283
RADIUS	▪ 6985.516
PC STATION	▪ 20+141.439 (A)
PT STATION	▪ 20+236.722 (A)
PI NUMBER	▪ 50
PI STATION	▪ 20+397.665 (A)
DELTA	▪ 0°15'42.03"RT
TANGENT	▪ 15.952
LENGTH	▪ 31.904
RADIUS	▪ 6985.516
PC STATION	▪ 20+381.713 (A)
PT STATION	▪ 20+413.617 (A)

SHEET TOTALS			
EST.	FINAL	UNIT	DESCRIPTION

**SH 35  
PLAN & PROFILE**

STA. 20+120 TO STA. 20+420

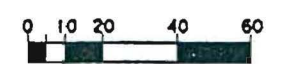

SCALE:  
PLAN 1:500  
PROFILE 1:50

SHEET 21 OF 45 SHEETS

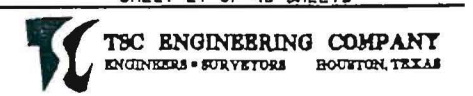

FED. RD. DIV. NO.	FEDERAL AID PROJECT NO.		SHEET NO.
6			
STATE	DIST.	COUNTY	
TEXAS	12	BRAZORIA	
COMT.	SECT.	JOB	HIGHWAY NO.
0179	02	068	SH 35

LEVELS DISPLAYED  
1 2 3 4 5 6 7 8 9 10 11 12 13 14 15 16  
ACC\*  
FILE: S35RPP21.DGN



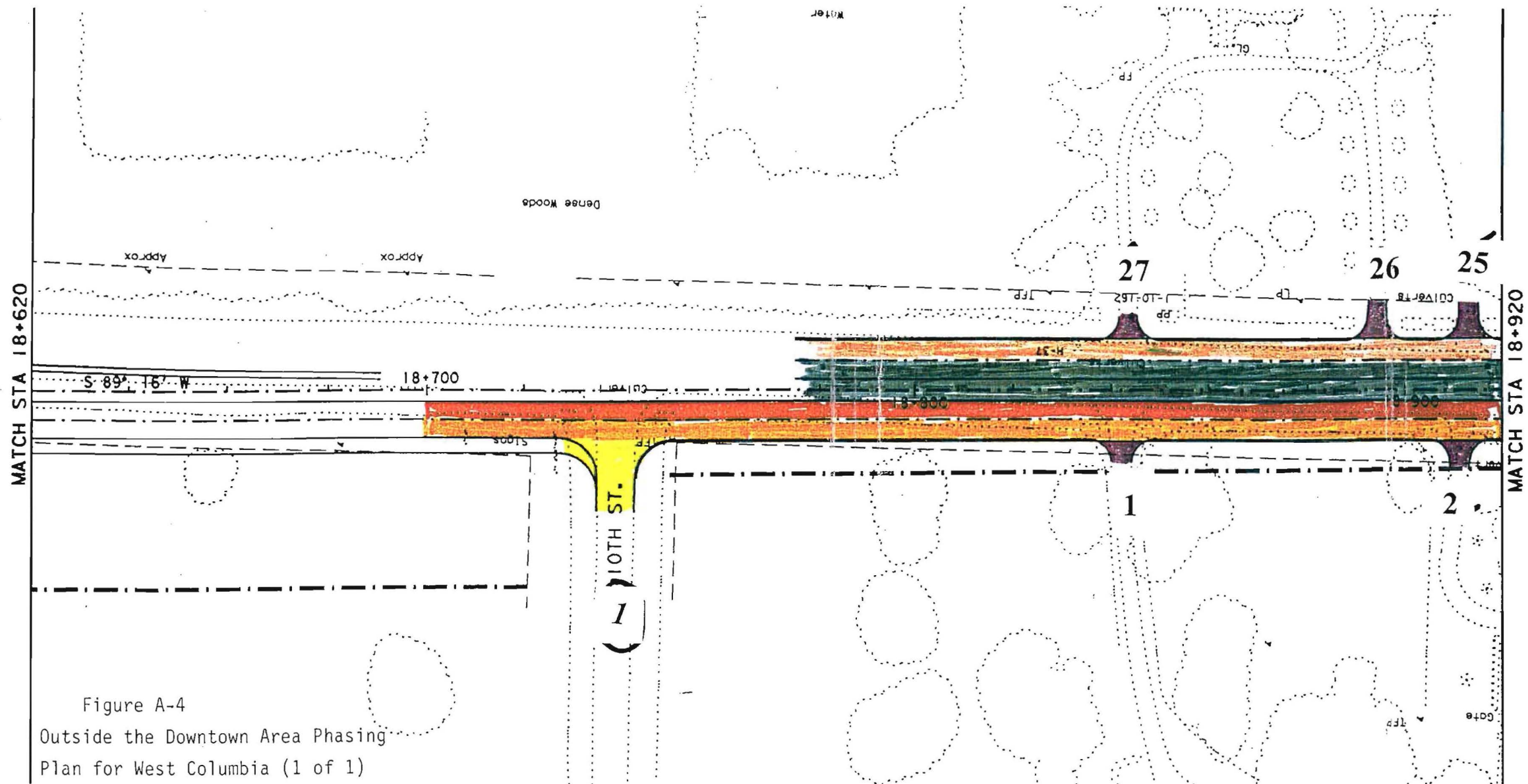





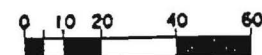



Figure A-4  
 Outside the Downtown Area Phasing  
 Plan for West Columbia (1 of 1)

SHEET TOTALS			
EST.	FINAL	UNIT	DESCRIPTION

	PHASE 1-A		PHASE 1+2 INTERSECTIONS
	PHASE 1-B		PHASE 1+2 DRIVEWAYS
	PHASE 2-B		
	PHASE 2-A		

SH 35  
 PLAN & PROFILE  
 STA. 18+620 TO STA. 18+920  
  
 SCALE:  
 PLAN 1:500  
 PROFILE 1:50  
 SHEET 16 OF 45 SHEETS

 **T&C ENGINEERING COMPANY**  
 ENGINEERS • SURVEYORS BOUSTON, TEXAS

 Texas Department of Transportation

FED. RD. DIV. NO.	FEDERAL AID PROJECT NO.		SHEET NO.
6			
STATE	DIST.	COUNTY	
TEXAS	12	BRAZORIA	
COMT. SECT.	JOB	HIGHWAY NO.	
0179	02	068	SH 35

LEVELS DISPLAYED  
 11 12 13 14 15 16 17 18 19 20 21 22 23 24 25 26 27 28 29 30 31 32 33 34 35 36 37 38 39 40 41 42 43 44 45 46 47 48 49 50 51 52 53 54 55 56 57 58 59 60 61 62 63 64 65 66 67 68 69 70 71 72 73 74 75 76 77 78 79 80 81 82 83 84 85 86 87 88 89 90 91 92 93 94 95 96 97 98 99 100  
 ACC\*  
 FILE: S35 RPP16.DGN

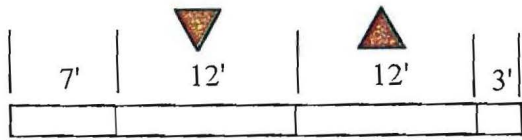

Existing Typical  
18+700 - 19+700  
and 20+200 - 22+250

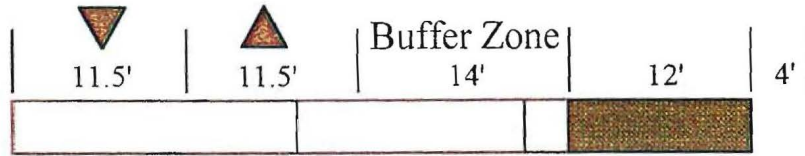

Phase 1A - Construction  
Traffic Controls

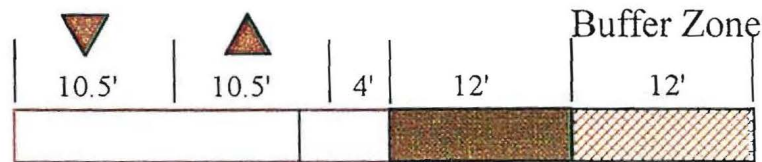

Phase 1B - Construction  
Traffic Controls

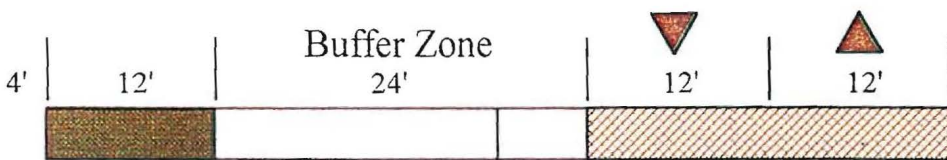

Phase 2A - Construction  
Traffic Controls



Phase 2B - Construction  
Traffic Controls

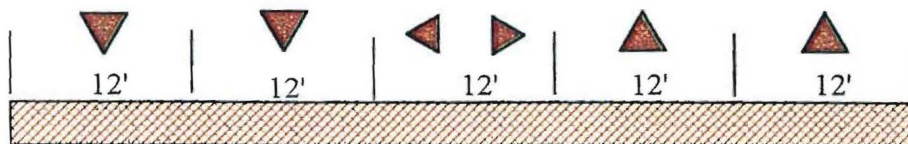

Proposed Typical

Figure A-5

Cross-section of Phasing Plan for  
Outside the Downtown Area



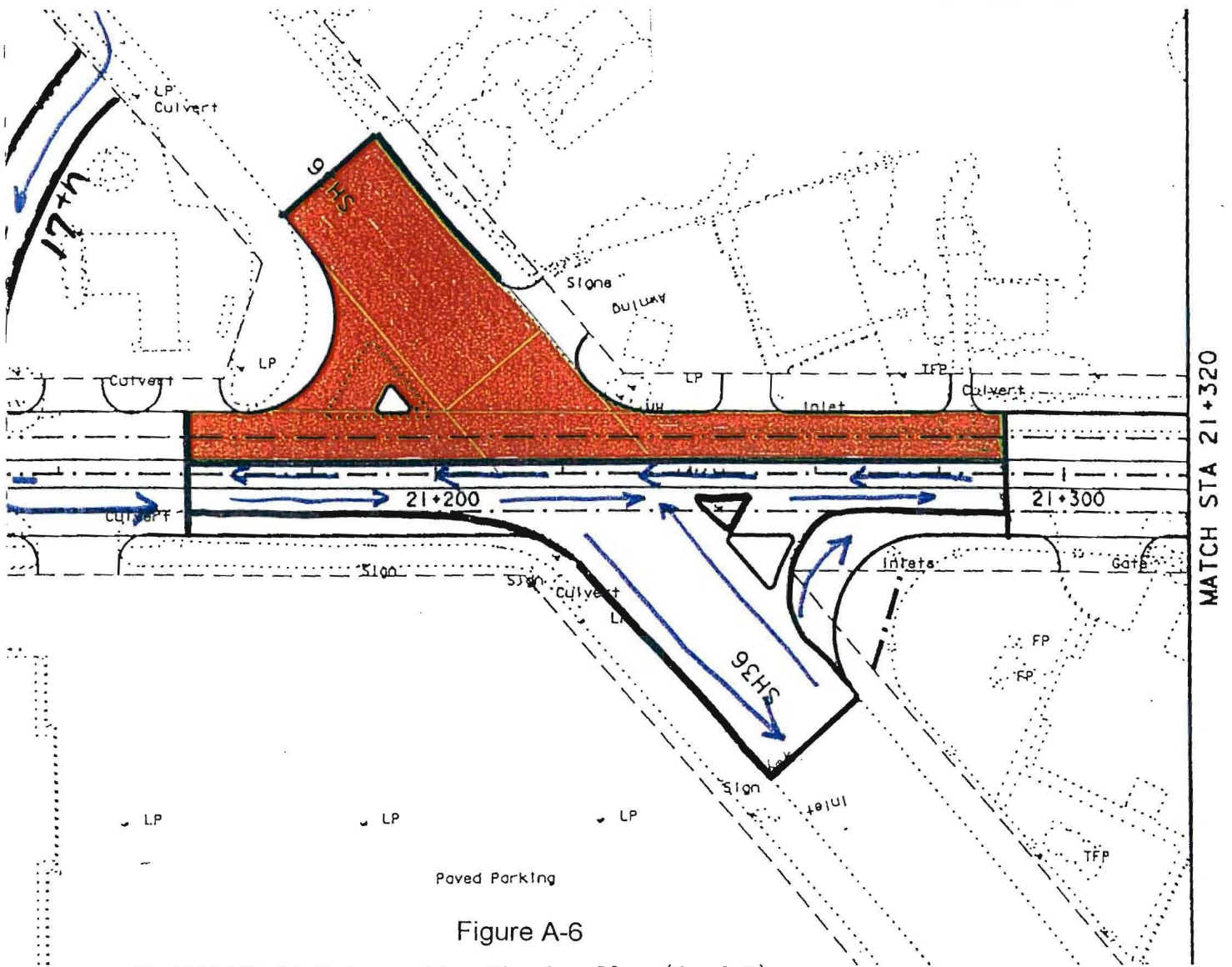

Figure A-6

CR 1301/SH 36 Intersection Phasing Plan (1 of 3)

\* ALL NORTHBOUND 36 TRAFFIC WILL BE DETOURED TO 35N. FROM THERE, ALL MANEUVERS ARE POSSIBLE.

\* ALL SOUTHBOUND TRAFFIC ON 36 + 1301 WILL BE DETOURED TO 35S.

\* 35N + 35S ARE 17th STREET







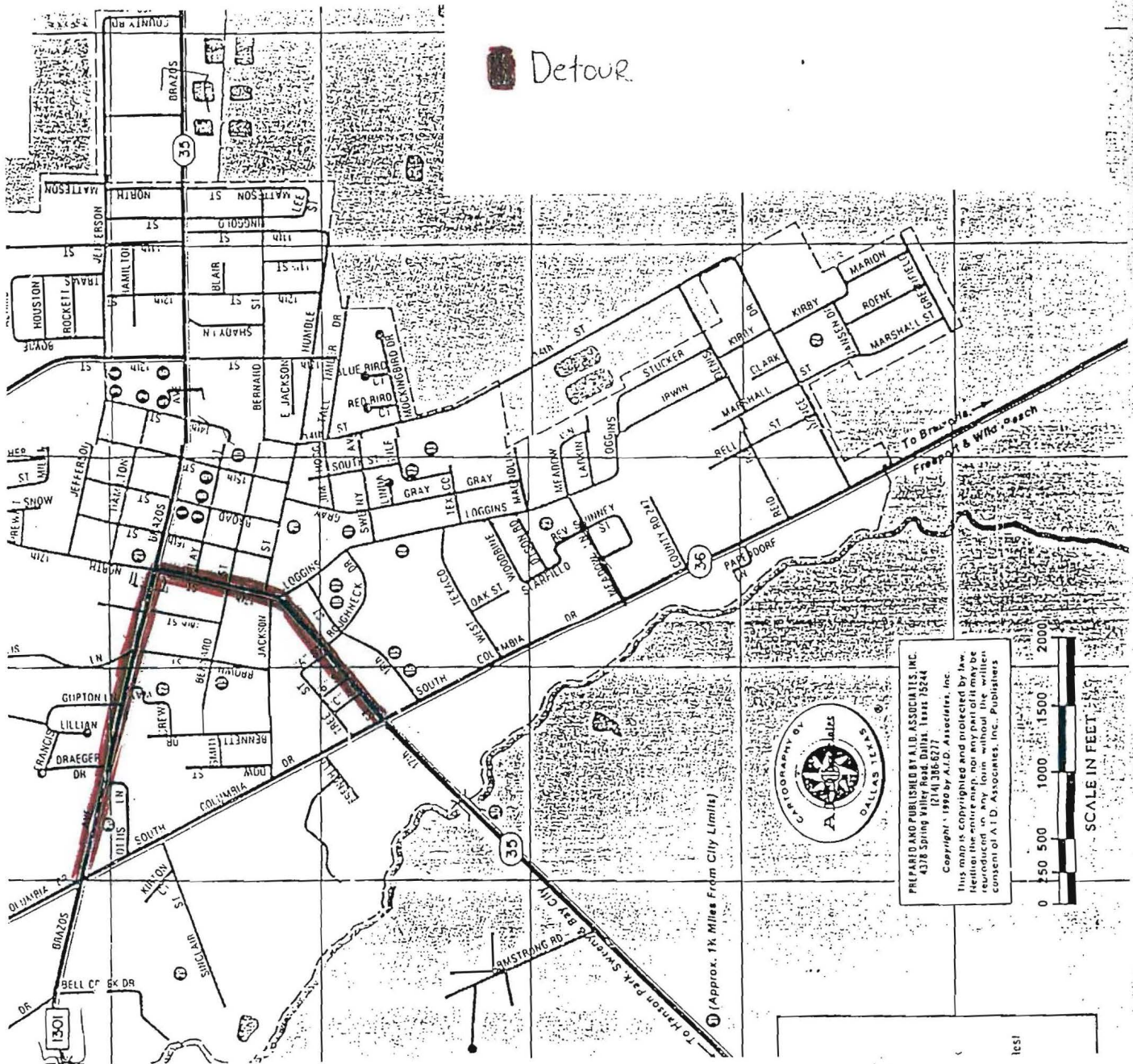

Figure A-9  
City Map of West Columbia

**APPENDIX B:**  
**RED BLUFF / BELTWAY 8 PROJECT**





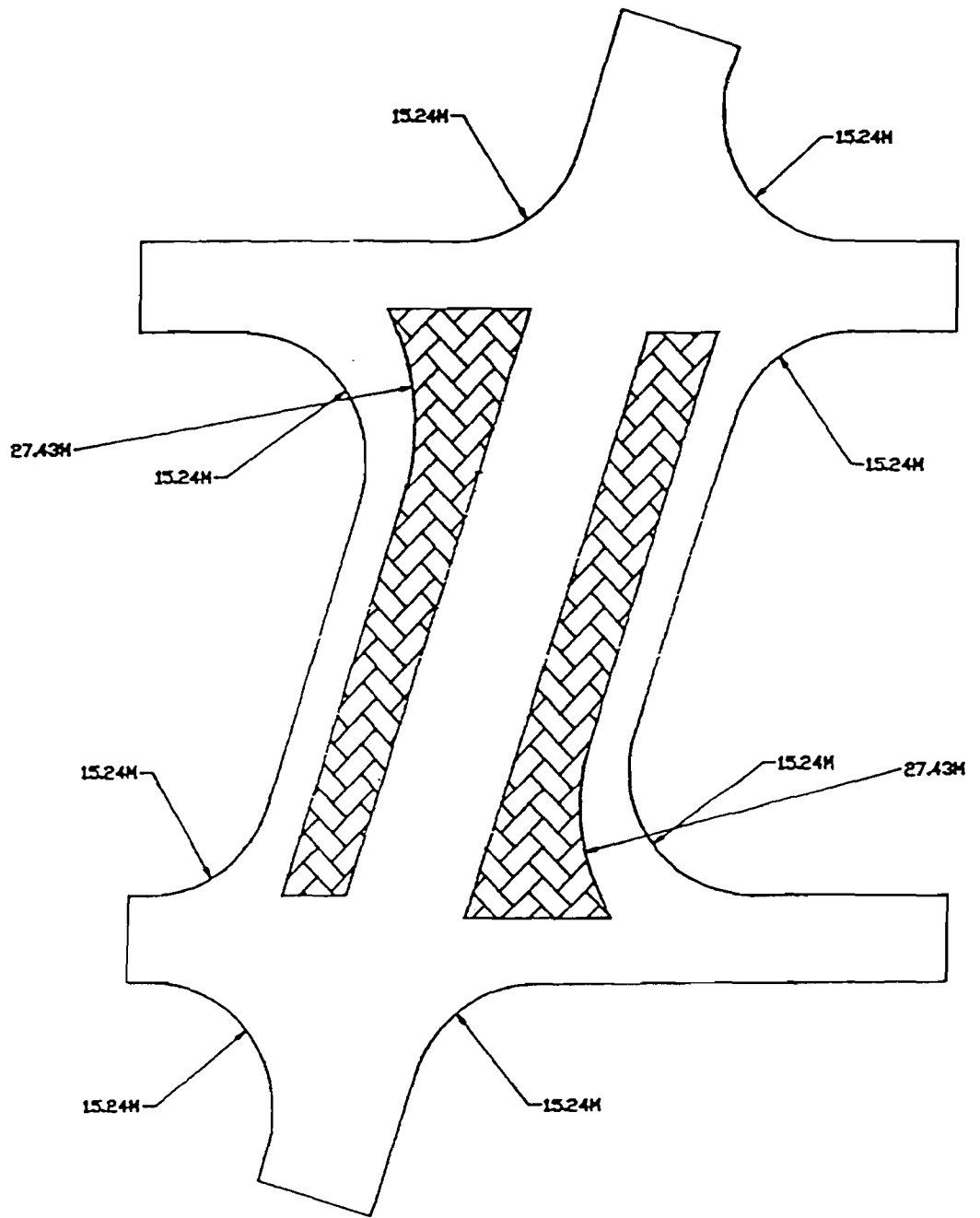

Figure B-1  
Red Bluff/Beltway 8 Intersection  
(1 of 2)

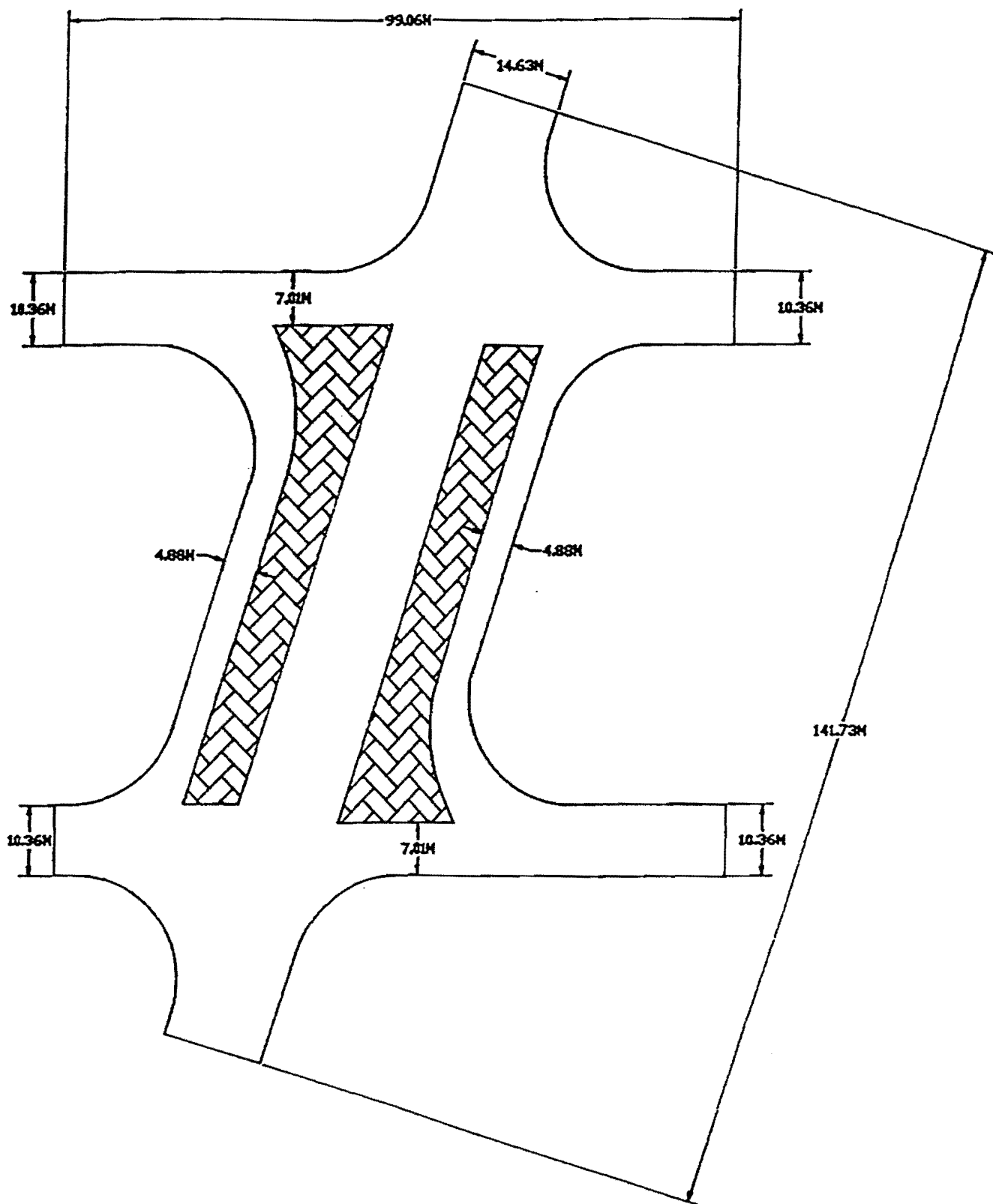

Figure B-2  
 Red Bluff/Beltway 8 Intersection  
 (2 of 2)

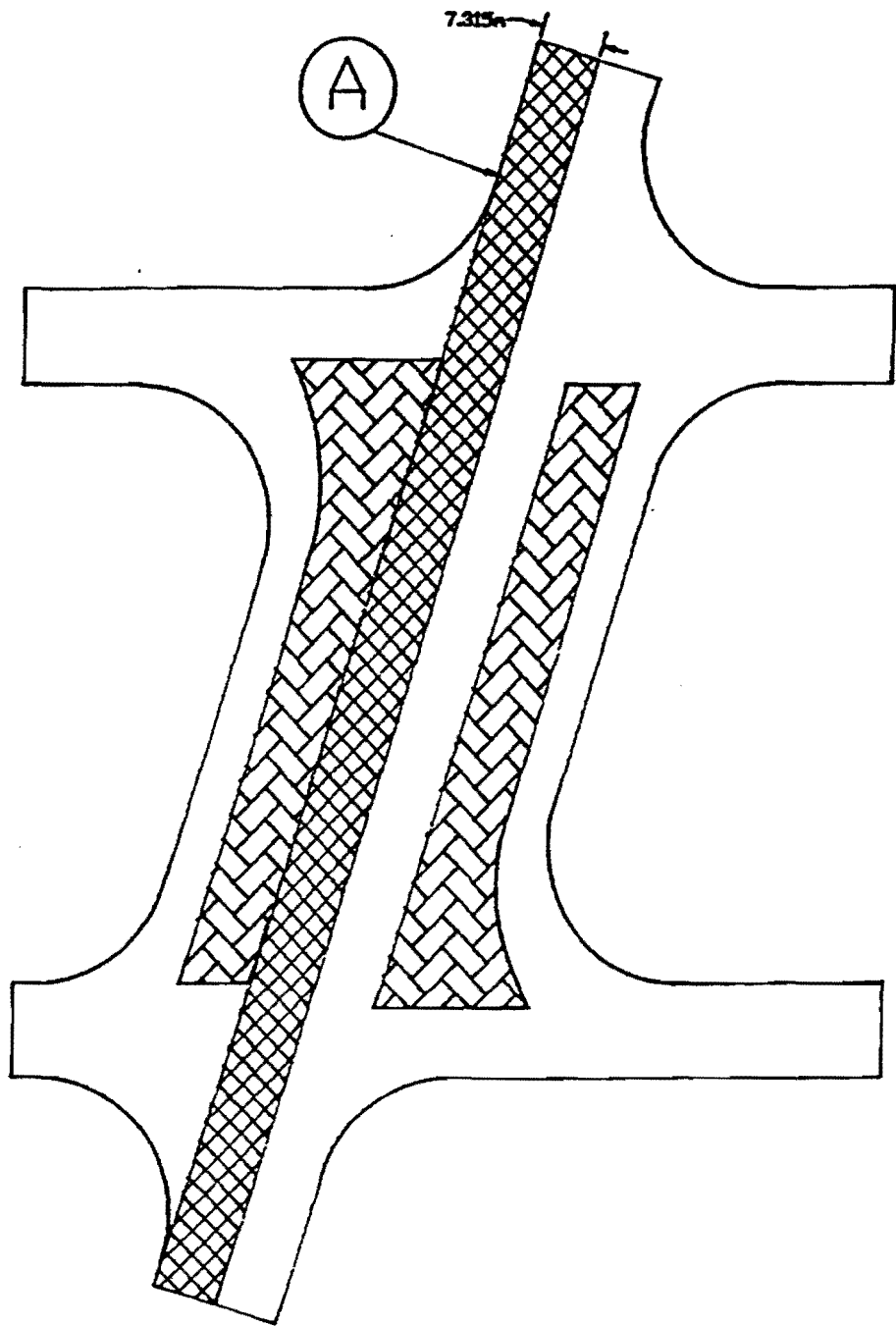

Figure B-3  
Construction Phases for  
Red Bluff/Beltway 8 Intersection (1 of 8)

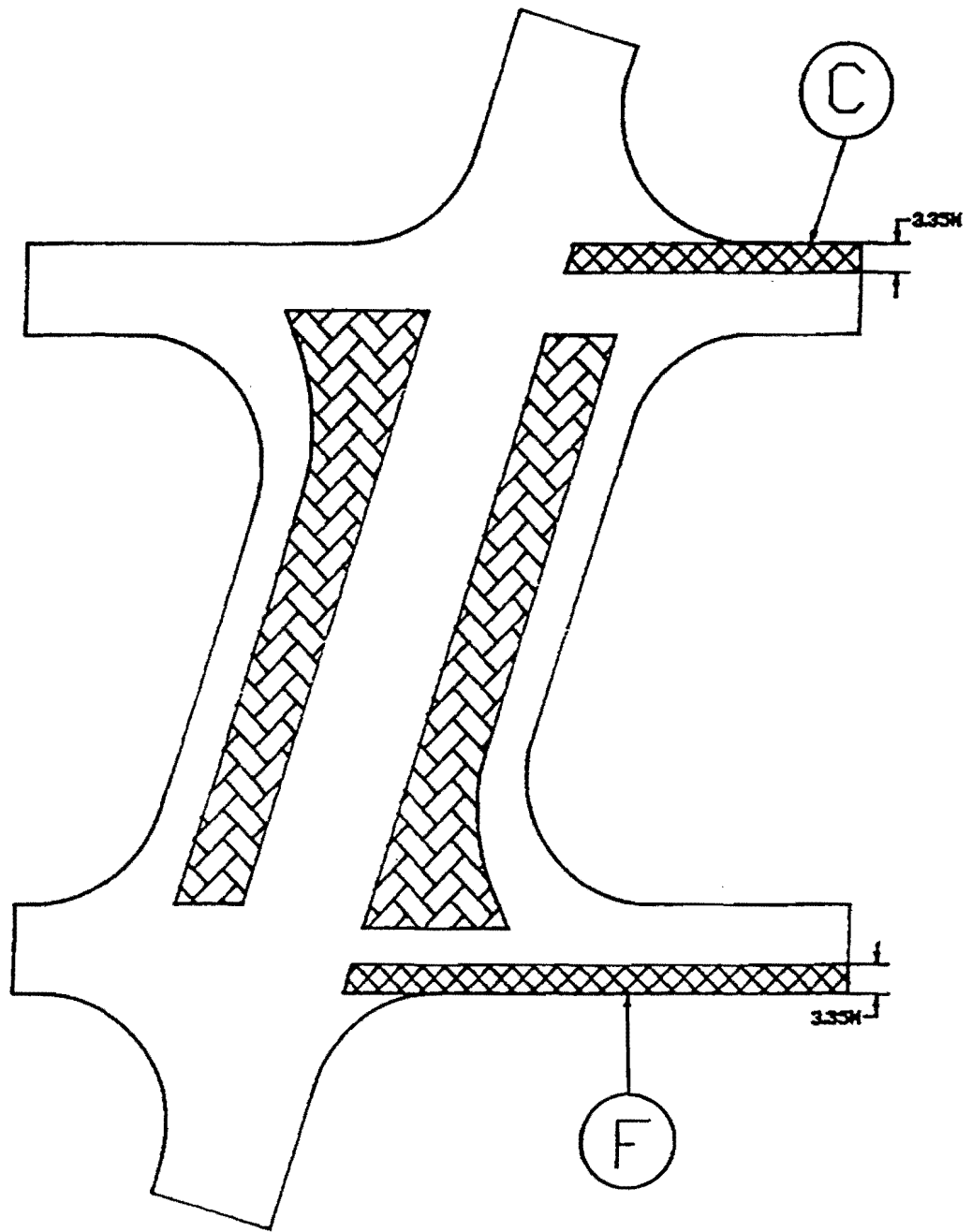

Figure B-4  
 Construction Phases for  
 Red Bluff/Beltway 8 Intersection (2 of 8)

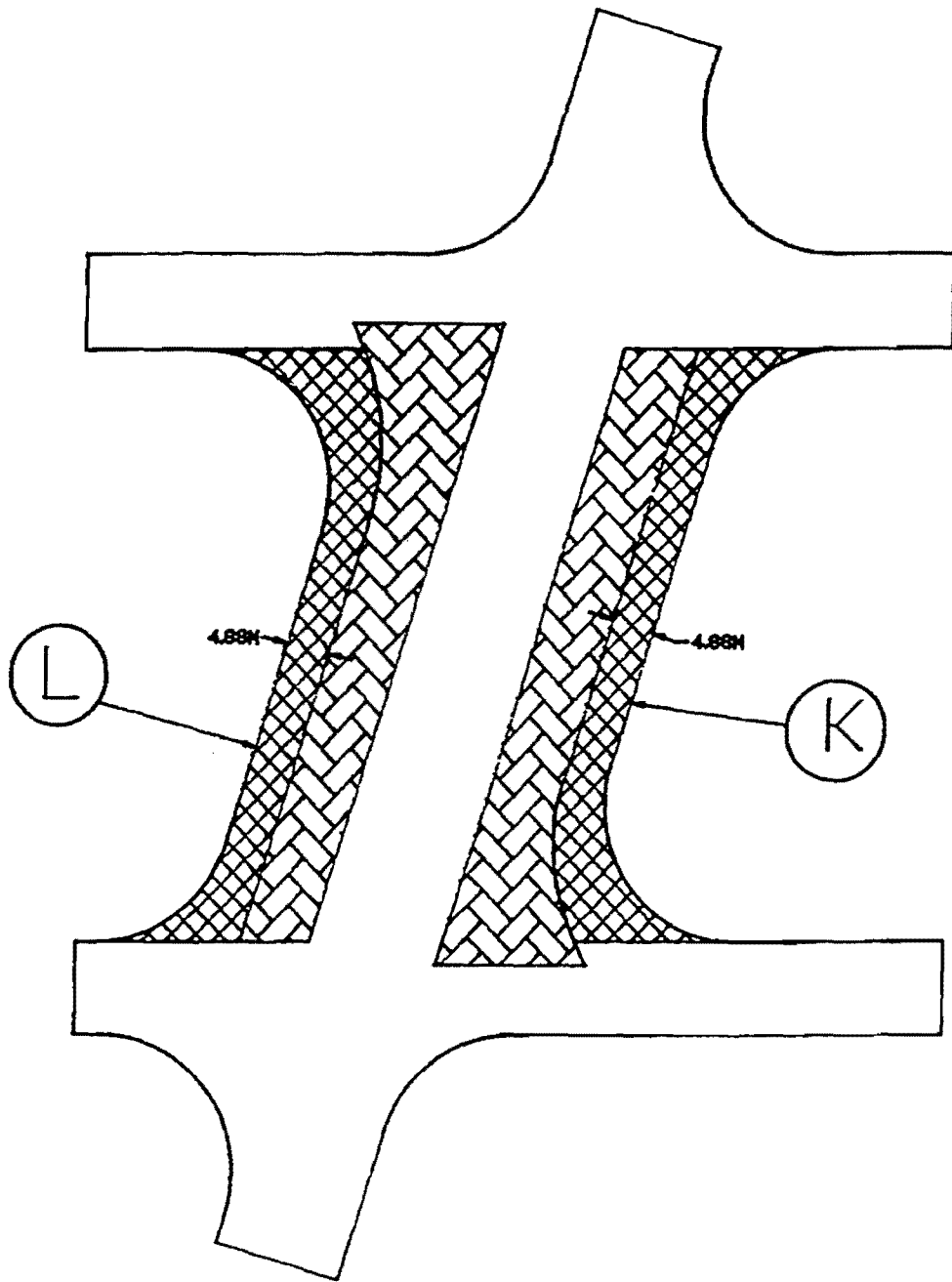

Figure B-5  
Construction Phases for  
Red Bluff/Beltway 8 Intersection (3 of 8)

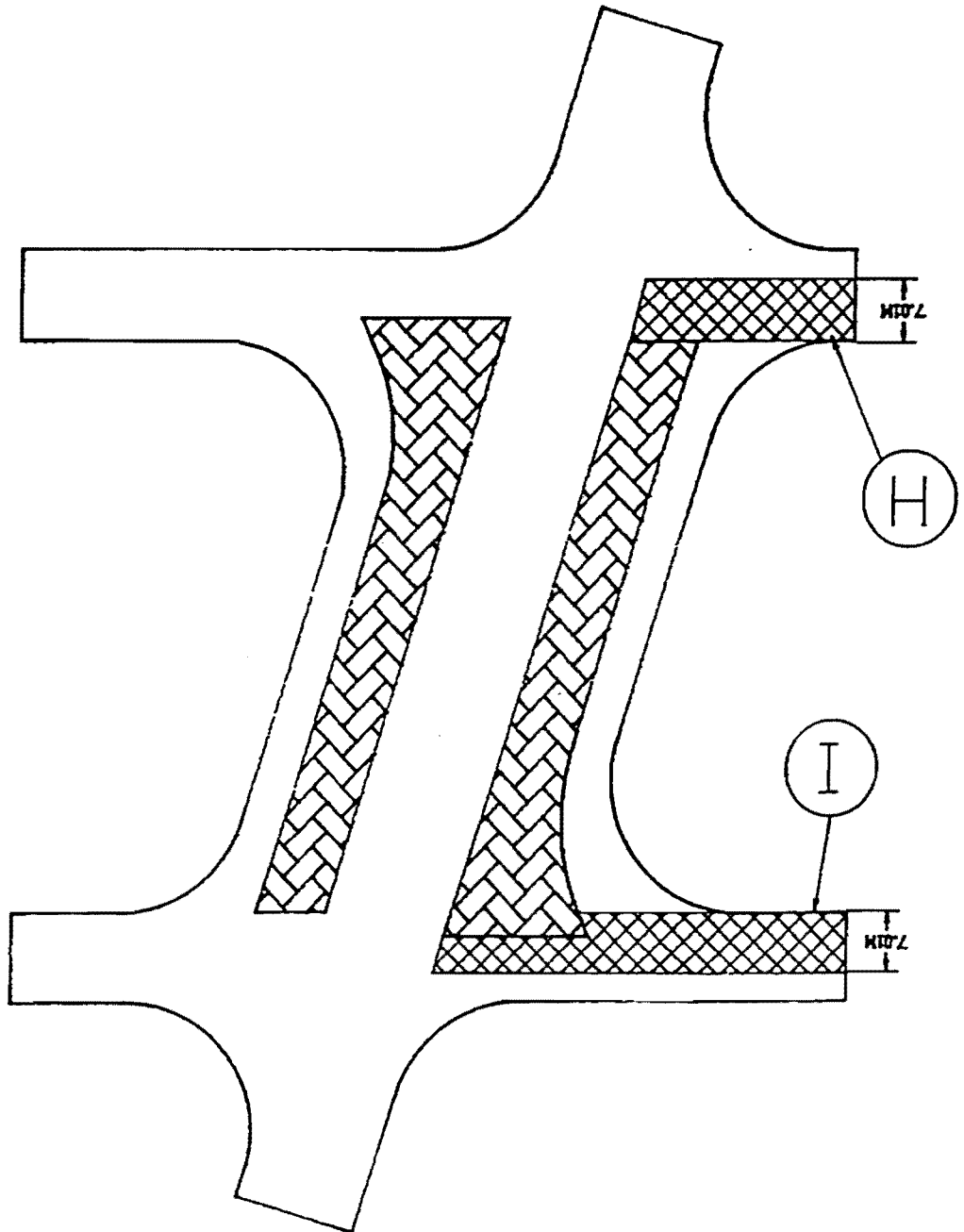

Figure B-6  
Construction Phases for  
Red Bluff/Beltway 8 Intersection (4 of 8)

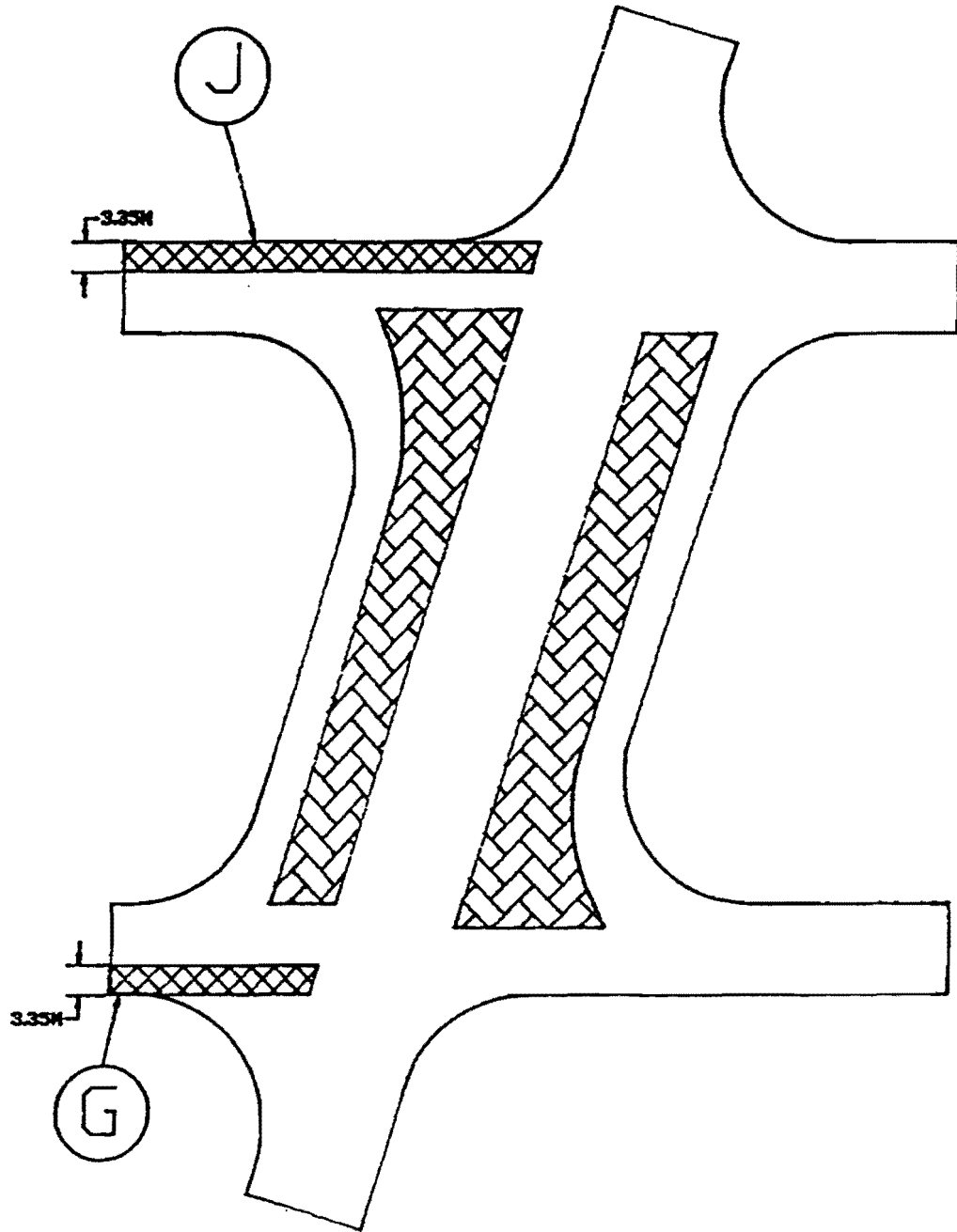

Figure B-7  
Construction Phases for  
Red Bluff/Beltway 8 Intersection (5 of 8)



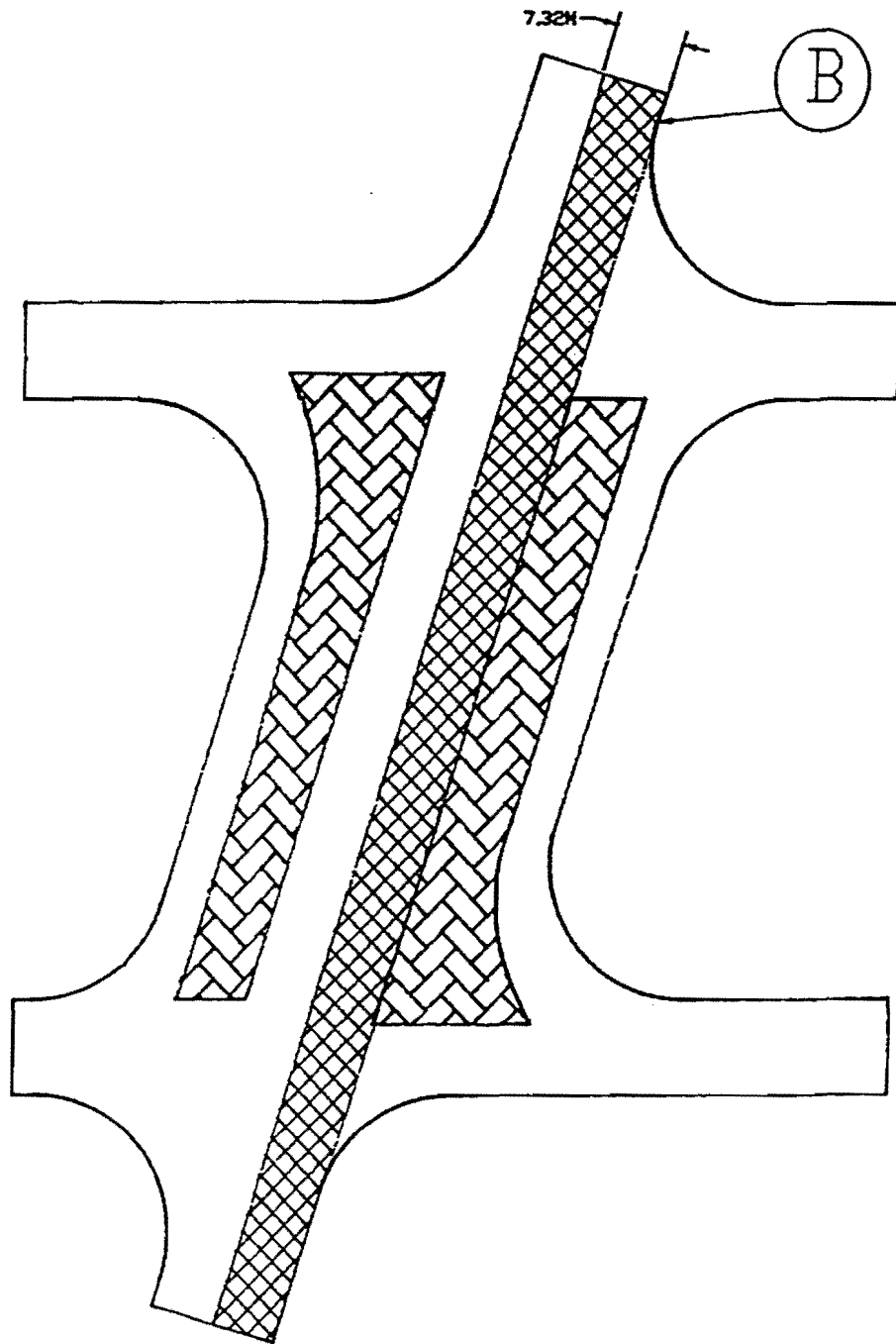

Figure B-8  
Construction Phases for  
Red Bluff/Beltway 8 Intersection (6 of 8)

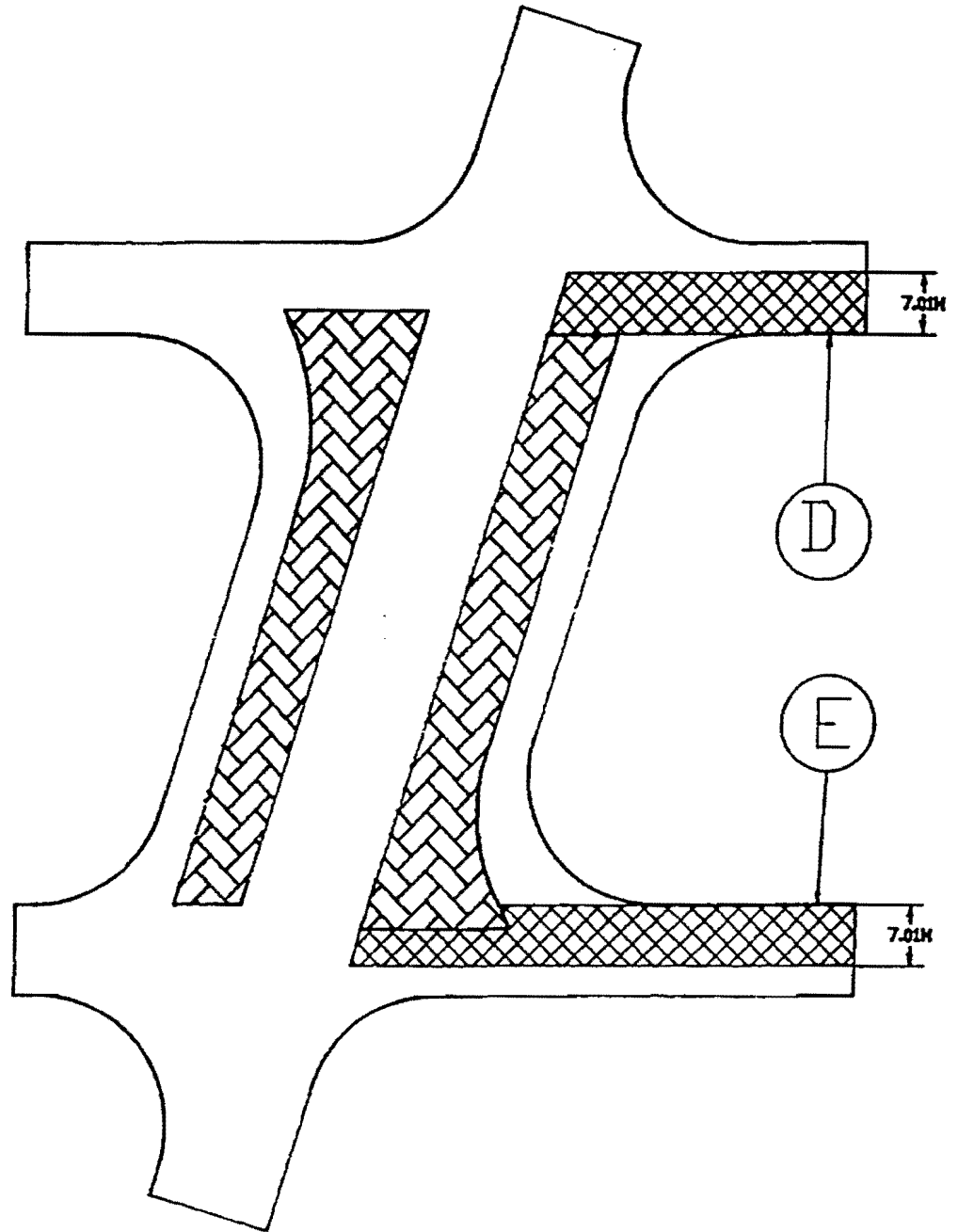

Figure B-9  
Construction Phases for  
Red Bluff/Beltway 8 Intersection (7 of 8)

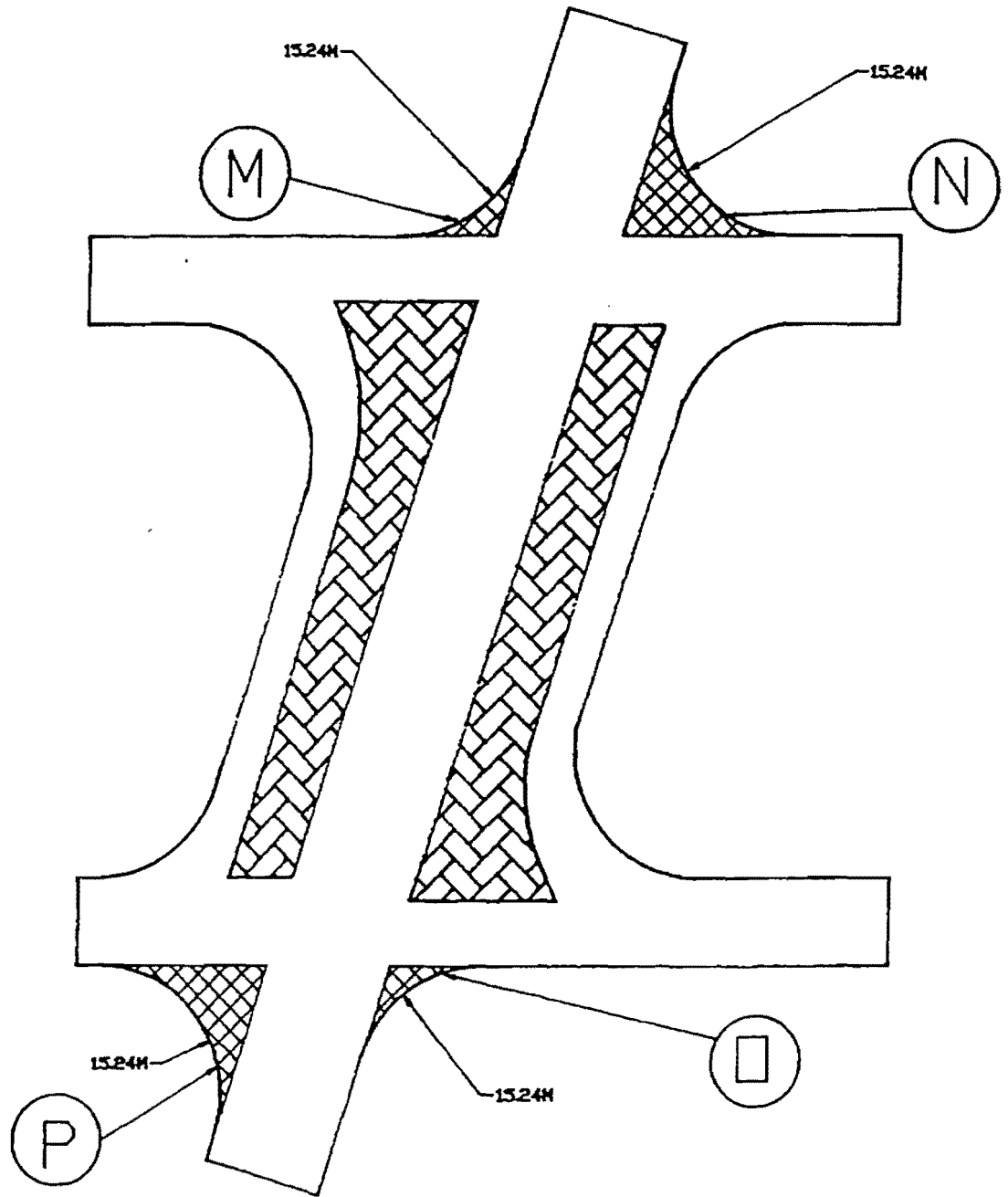

Figure B-10  
 Construction Phases for  
 Red Bluff/Beltway 8 Intersection (8 of 8)

Table B1 - Pour Section Data

Section	Area (SY)	Concrete Needed (CY)	Rebar Needed (Cwt)	Demo Time (Hours)	Form Time (Hours)	Rebar Time (Hours)	Concrete Time (Hours)
A	1240	379	438	2.86	4.89	4.46	5.10
B	1240	379	438	2.86	2.565	4.46	5.10
C	138	42	49	0.32	1.235	0.50	0.57
D	300	92	106	0.69	1.29	1.08	1.24
E	433	132	153	1.00	2.08	1.56	1.78
F	239	73	84	0.55	2.065	0.86	0.98
G	97	30	34	0.22	0.845	0.35	0.40
H	215	66	76	0.49	0.955	0.77	0.88
I	349	107	123	0.80	1.75	1.26	1.44
J	199	61	70	0.46	1.68	0.72	0.82
K	402	123	142	0.93	2.3	1.45	1.66
L	402	123	142	0.93	2.3	1.45	1.66
M	98	30	35	0.23	0.2	0.35	0.40
N	98	30	35	0.23	0.2	0.35	0.40
O	98	30	35	0.23	0.2	0.35	0.40
P	98	30	35	0.23	0.2	0.35	0.40

Table B2  
Construction Sequence

Construction Sequencing	Crew 1	Crew 2
Phase 1	A	F
Phase 2	L	C
Phase 3	J	K
Phase 4	G	I
Phase 5	B	H
Phase 6	O	M
Phase 7	D	P
Phase 8	N	E

Table B3  
 Construction Methods for  
 Red Bluff / Beltway 8  
 Intersection

Phase	Method	Production Rate
Demolition / Excavation	Breakers, Excavators, Bulldozers, Graders, Rollers	434 SY of Area / Hour
Formwork	Standard Labor	200 LF of Forms / Hour
Steel Placement	Standard Labor	278 SY of Area / Hour
Concrete Placement	Air Screed	75 CY of Concrete / Hour

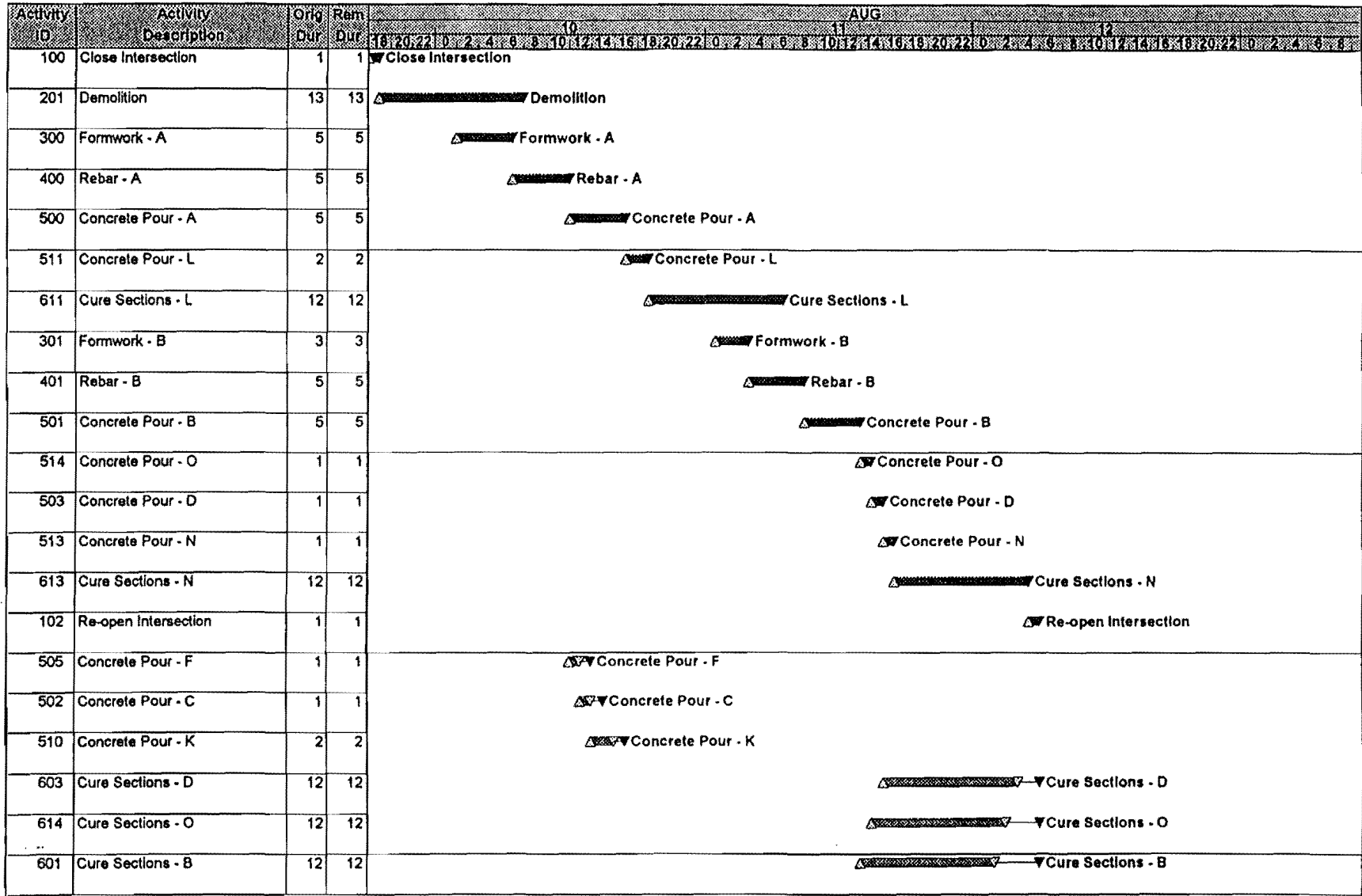

Project Start	08AUG08 16:00	▲ Early Bar
Project Finish	12AUG08 06:00	▼ Float Bar
Data Date	08AUG08 16:00	▲ Progress Bar
Plot Date	16NOV08 11:00	▲ Critical Activity

Figure B-11  
 Construction Schedule - Red Bluff Intersection  
 (1 of 3)

Activity ID	Activity Description	Orig Dur	Rem Dur	AUG																															
				10							11							12																	
				18	20	22	0	2	4	6	8	10	12	14	16	18	20	22	0	2	4	6	8	10	12	14	16	18	20	22	0	2	4	6	8
307	Formwork - H	1	1	▼ Formwork - H																															
308	Formwork - I	2	2	▼ Formwork - I																															
315	Formwork - P	1	1	▼ Formwork - P																															
312	Formwork - M	1	1	▼ Formwork - M																															
313	Formwork - N	1	1	▼ Formwork - N																															
314	Formwork - O	1	1	▼ Formwork - O																															
414	Rebar - O	1	1	▼ Rebar - O																															
302	Formwork - C	1	1	▼ Formwork - C																															
305	Formwork - F	2	2	▼ Formwork - F																															
310	Formwork K	2	2	▼ Formwork K																															
311	Formwork - L	2	2	▼ Formwork - L																															
410	Rebar - K	2	2	▼ Rebar - K																															
411	Rebar - L	2	2	▼ Rebar - L																															
408	Rebar - I	1	1	▼ Rebar - I																															
508	Concrete Pour - I	2	2	▼ Concrete Pour - I																															
507	Concrete Pour - H	1	1	▼ Concrete Pour - H																															
512	Concrete Pour - M	1	1	▼ Concrete Pour - M																															
515	Concrete Pour - P	1	1	▼ Concrete Pour - P																															
504	Concrete Pour - E	2	2	▼ Concrete Pour - E																															
604	Cure Sections - E	12	12	▼ Cure Sections - E																															
405	Rebar - F	1	1	▼ Rebar - F																															
304	Formwork - E	2	2	▼ Formwork - E																															
303	Formwork - D	1	1	▼ Formwork - D																															

Figure B-11

Construction Schedule - Red Bluff Intersection



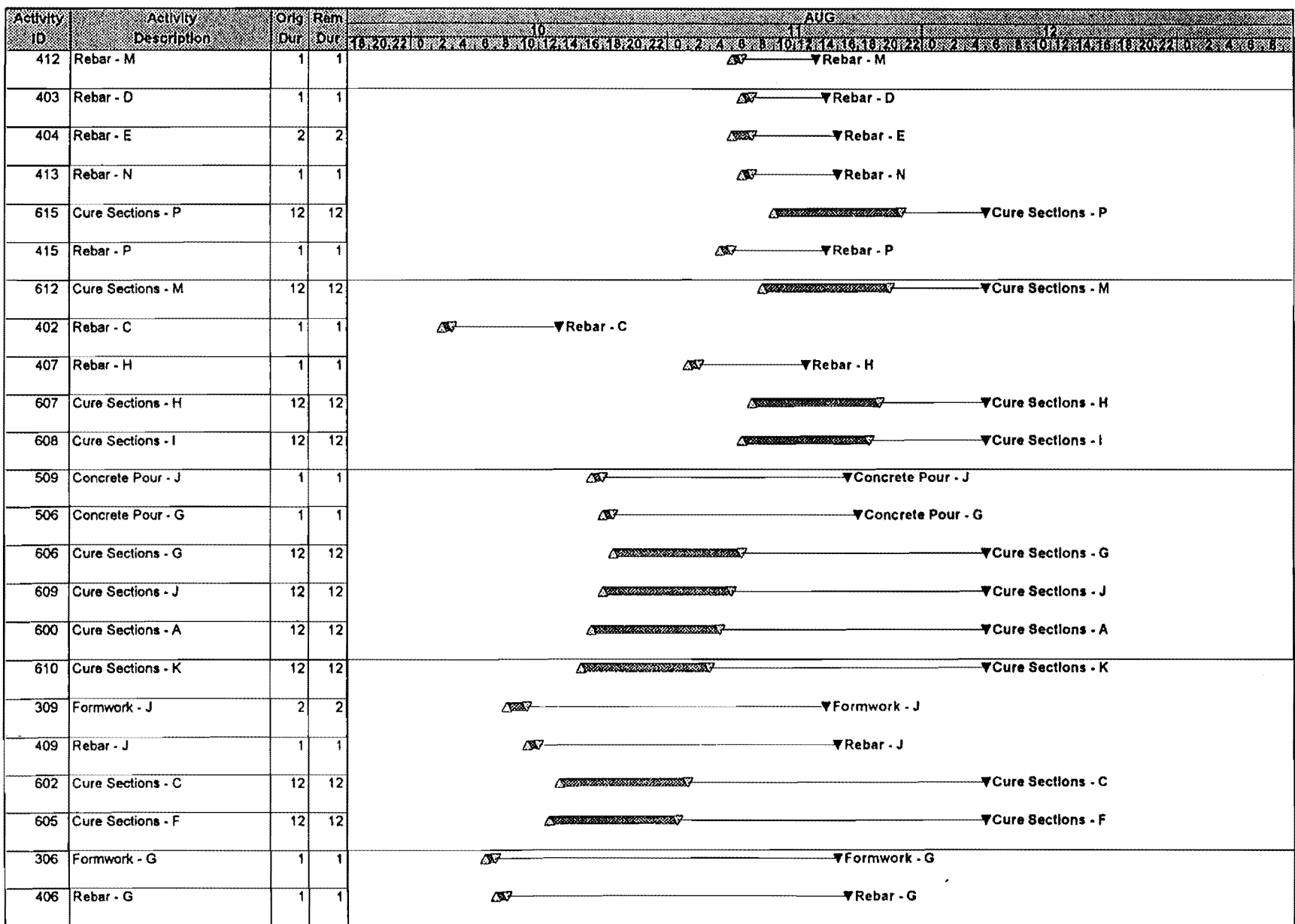

Figure B-11  
 Construction Schedule - Red Bluff Intersection  
 (3 of 3)

Table B4  
Cost Estimate for  
Red Bluff Intersection

Red Bluff - Beltway 8 Intersection					
Description	Quantity	Unit	Rate	Total	Total
<b>Materials</b>					
Concrete	1725	CY	\$ 75.00	\$ 129,375.00	
Steel	1993	CWt	\$ 17.75	\$ 35,375.75	
Embedded materials	5645	SY	\$ 0.35	\$ 1,975.75	
Screwbars, dowels, etc.	5645	SY	\$ 0.47	\$ 2,653.15	
Cotton Mats	300	Ea	\$ 23.00	\$ 6,900.00	
Poly	25	Ea	\$ 25.00	\$ 625.00	
<b>Total</b>					<b>\$ 176,904.65</b>
<b>Labor</b>					
Description	Quantity	Rate	Hours	Total	Total
<b>Demolition</b>					
Machine Operators	9	\$ 40.00	13	\$ 4,680.00	
Laborers	4	\$ 20.00	5	\$ 400.00	
Dump Truck Drivers	10	\$ 20.00	13	\$ 2,600.00	
<b>Survey</b>					
Crew-3men	2	\$ 775.00		\$ 1,550.00	
<b>Forms</b>					
Laborers	12	\$ 20.00	25	\$ 6,000.00	
<b>2crews - 12 men</b>					
<b>Steel</b>					
Laborers	10	\$ 20.00	21	\$ 4,200.00	
<b>2crews - 10 men</b>					
<b>Concrete</b>					
Laborers	20	\$ 20.00	24	\$ 9,600.00	
<b>2 crews - 20 men</b>					
Mix Truck Drivers	20	\$ 20.00	24	\$ 9,600.00	
<b>Total</b>					<b>\$ 38,630.00</b>
<b>Equipment</b>					
Description	Quantity	Rate	Total	Total	Total
Excavators	4	\$ 2,000.00	\$ 8,000.00		
Breakers	2	\$ 490.00	\$ 980.00		
Dozers	2	\$ 490.00	\$ 980.00		
Graders	2	\$ 1,200.00	\$ 2,400.00		
Rollers	1	\$ 260.00	\$ 260.00		
Dump Trucks	10	\$ 420.00	\$ 4,200.00		
Concrete Mix Trucks	20	\$ 1,000.00	\$ 20,000.00		
Air Screeds	2	\$ 1,000.00	\$ 2,000.00		
Forms	150	\$ 10.00	\$ 1,500.00		
<b>Total</b>					<b>\$ 40,320.00</b>
<b>Project Total</b>					<b>\$ 255,854.65</b>
<b>Bond - 1%</b>					<b>\$ 2,558.55</b>
<b>OH&amp;P - 20%</b>					<b>\$ 51,170.93</b>
<b>Total</b>					<b>\$ 309,584.13</b>



**APPENDIX C:**  
**TIME, TEMPERATURE, AND MATURITY DATA FOR**  
**LABORATORY TESTS**



**Table C-1 Time, Temperature, and Maturity Data for 60° F Samples**

<b>Time (hr)</b>	<b>Temperature (°C)</b>	<b>Maturity (°C-hr)</b>
0.00	18.3	0
1.50	18.2	43
2.08	17.4	60
2.75	16.9	77
3.58	16.5	98
4.25	16.4	115
5.00	16.2	136
5.50	16.2	147
6.00	16.4	160
7.08	16.5	189
8.08	16.9	215
10.17	17.6	271
10.67	17.4	284
12.00	17.1	319
19.08	16.4	493
21.75	16.1	572
23.75	15.9	621
24.75	15.8	648
25.22	15.7	658
25.97	15.7	676
27.50	15.6	715
28.92	15.4	749
30.83	15.4	798
32.42	15.3	837
33.42	15.2	862
35.50	15	914
44.75	15	1143
46.58	15	1189
47.58	15	1212

**Table C-2 Time, Temperature, and Maturity Data for 85° F Samples**

<b>Time (hr)</b>	<b>Temperature (°C)</b>	<b>Maturity (°C-hr)</b>
0.00	24.5	0
2.00	24.4	71
2.58	24.6	93
3.25	24.4	117
4.08	24.9	142
4.75	25.3	166
5.50	26	194
6.00	26.4	210
6.50	27	229
7.58	28	271
8.58	28.8	310
10.67	29.8	392
11.17	29.9	412
12.50	30.2	466
19.58	29.8	733
22.25	29.7	850
24.25	29.6	927
25.25	29.6	968
25.72	29.5	984
26.47	29.5	1013
28.00	29.4	1075
29.42	29.4	1129
31.33	29.2	1206
32.92	29.2	1266
33.92	29.1	1306
36.00	29.1	1386
45.25	28.9	1736
47.08	28.8	1808
48.08	28.7	1843

**APPENDIX D:**  
**STATISTICAL ANALYSIS OF LABORATORY DATA**





Statistical test for evaluating the variation of the intercept and slope values for different curing temperatures:

Intercept  $\beta_0$ :

$$H_0: \beta_{0,60} = \beta_{0,85}$$

$$H_a: \beta_{0,60} \neq \beta_{0,85}$$

$$T. S.: t = \frac{\beta_{0,60} - \beta_{0,85}}{s_\epsilon \sqrt{\frac{\sum x^2}{nS_{xx}}}}$$

where;

$\beta_{0,60}$  = Intercept of the linear trend line for 60 F Specimens

$\beta_{0,85}$  = Intercept of the linear trend line for 85 F Specimens

$\beta_{1,60}$  = Slope of the linear trend line for 60 F Specimens

$\beta_{1,85}$  = Slope of the linear trend line for 85 F Specimens

$$s_\epsilon = \sqrt{\frac{S_{yy} - \beta_{1,60}S_{xy}}{n-2}}$$

$$S_{xx} = \sum x^2 - \frac{(\sum x)^2}{n}$$

$$S_{xy} = \sum xy - \frac{\sum x \sum y}{n}$$

R. R.: For 90% confidence interval and  $df = n-2 = 1$ ;

Reject  $H_0$  if  $|t| > t_{0.05}$

$$t = -1.01028 \text{ and } t_{0.05} = 6.314$$

Conclusion: Fail to reject  $H_0$

and

$$H_0: \beta_{0,85} = \beta_{0,60}$$

$$H_a: \beta_{0,85} \neq \beta_{0,60}$$

$$T. S.: t = \frac{\beta_{0,85} - \beta_{0,60}}{s_\epsilon \sqrt{\frac{\sum x^2}{nS_{xx}}}}$$

where;

$$s_\epsilon = \sqrt{\frac{S_{yy} - \beta_{1,85}S_{xy}}{n-2}}$$

R. R.: For 90% confidence interval and  $df = n-2 = 2$ ;

Reject  $H_0$  if  $|t| > t_{0.05}$

$$t = -2.10115 \text{ and } t_{0.05} = 2.920$$

Conclusion: Fail to reject  $H_0$

Slope  $\beta_1$ :

$$H_0: \beta_{1,60} = \beta_{1,85}$$

$$H_a: \beta_{1,60} \neq \beta_{1,85}$$

$$T. S.: t = \frac{\beta_{1,60} - \beta_{1,85}}{\frac{s_\epsilon}{\sqrt{S_{xx}}}}$$

where;

$$s_e = \sqrt{\frac{S_{yy} - \beta_{1,60} S_{xy}}{n-2}}$$

R. R.: For 90% confidence interval and  $df = n-2 = 1$ ;

Reject  $H_0$  if  $|t| > t_{0,05}$

$$t = 1.11542 \text{ and } t_{0,05} = 6.314$$

Conclusion: Fail to reject  $H_0$

and

$$H_0: \beta_{1,85} = \beta_{1,60}$$

$$H_1: \beta_{1,85} \neq \beta_{1,60}$$

$$\text{T. S.: } t = \frac{\beta_{1,85} - \beta_{1,60}}{\frac{s_e}{\sqrt{S_{xx}}}}$$

where;

$$s_e = \sqrt{\frac{S_{yy} - \beta_{1,85} S_{xy}}{n-2}}$$

R. R.: For 90% confidence interval and  $df = n-2 = 2$ ;

Reject  $H_0$  if  $|t| > t_{0,05}$

$$t = 0.993698 \text{ and } t_{0,05} = 2.920$$

Conclusion: Fail to reject  $H_0$

**APPENDIX E:**  
**CHASEWOOD PARK DRIVE (SH 249) PROJECT**



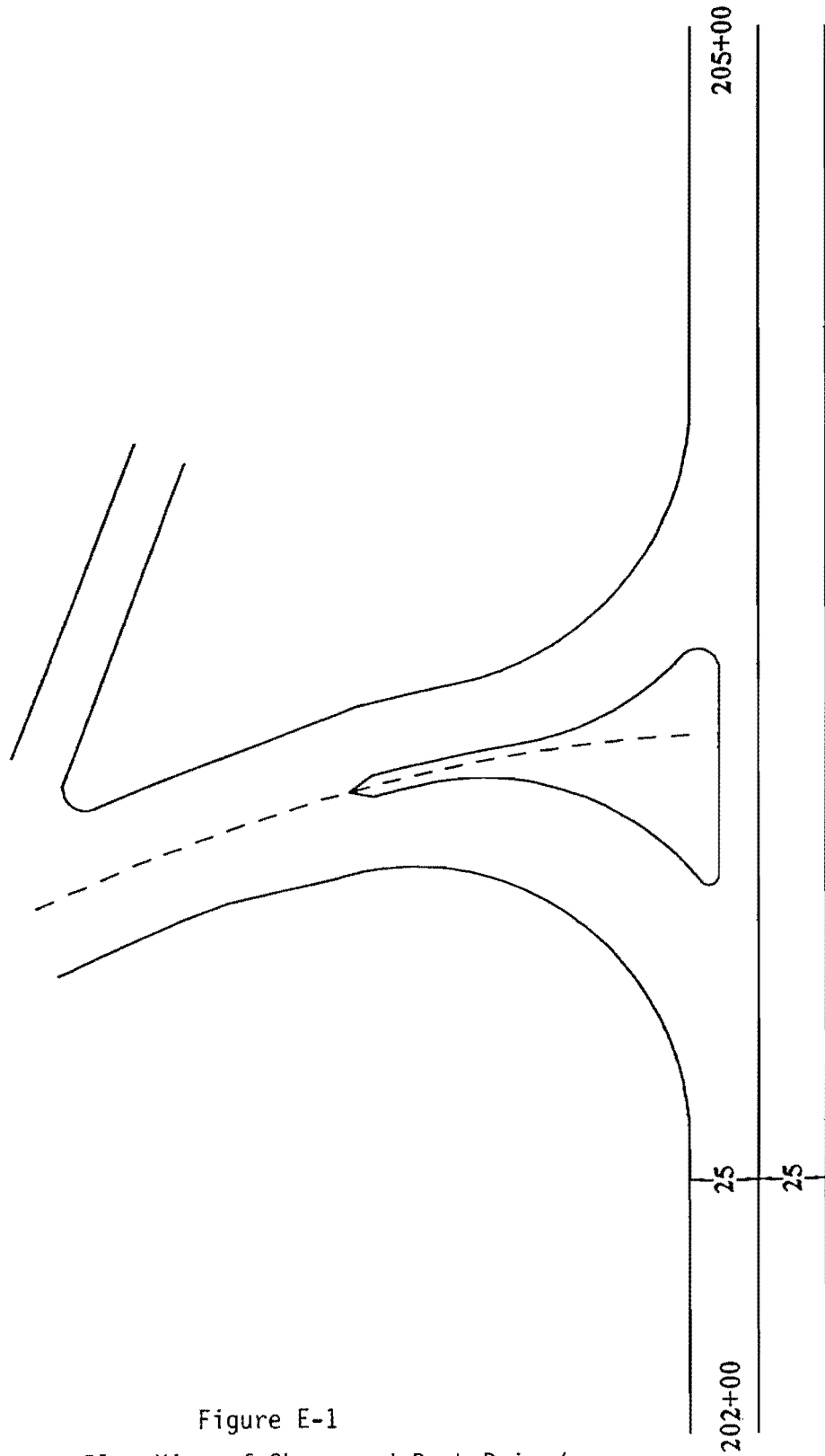

Figure E-1  
 Plan View of Chasewood Park Drive/  
 SH 249 Intersection

144

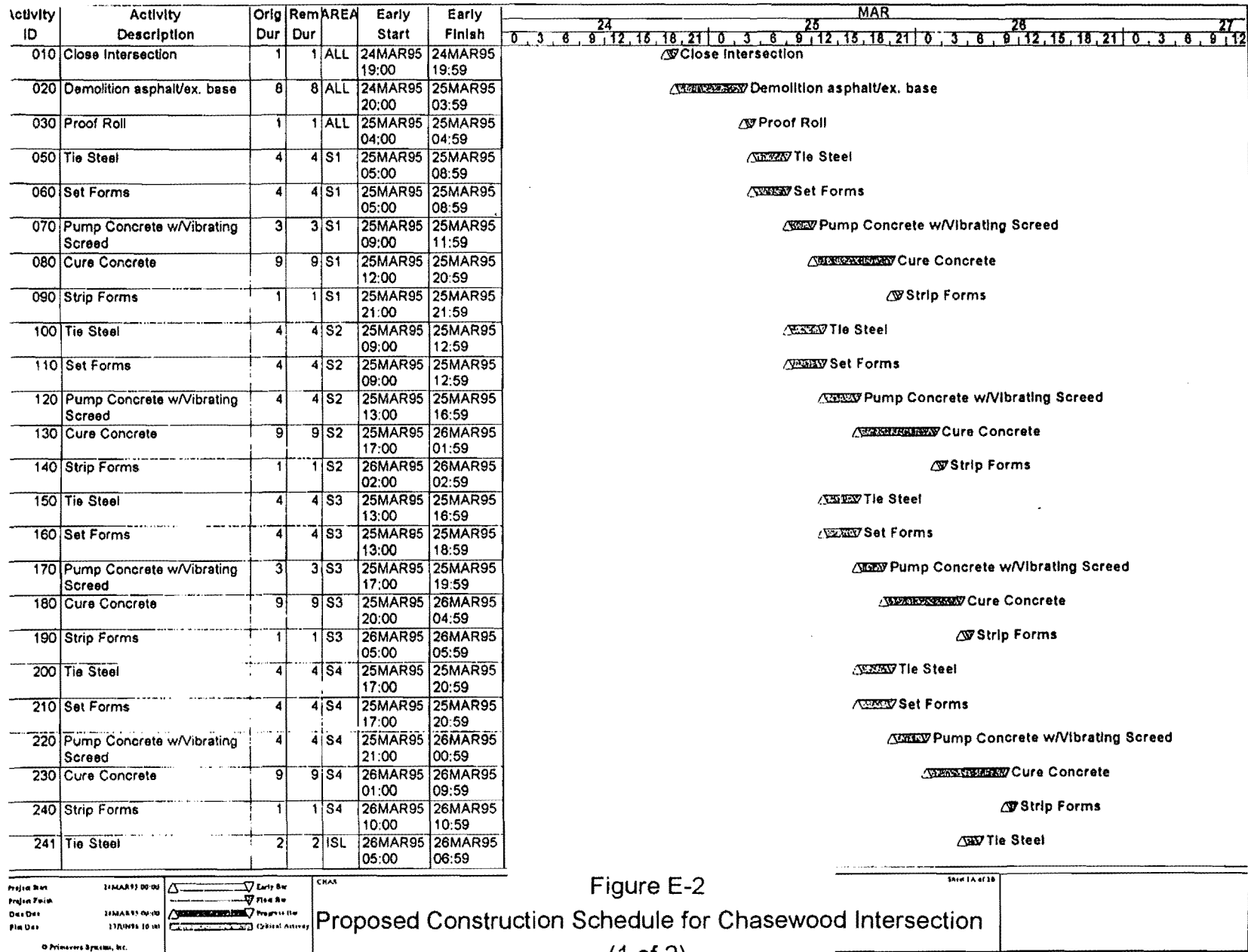

Figure E-2  
 Proposed Construction Schedule for Chasewood Intersection  
 (1 of 2)

Activity ID	Activity Description	Orig Dur	Rem Dur	AREA	Early Start	Early Finish	MAR																				
							24				25				26												
							0	3	6	9	12	15	18	21	0	3	6	9	12	15	18	21	0	3	6	9	12
242	Set Forms	2	2	ISL	26MAR95 05:00	26MAR95 08:59	Set Forms																				
243	Pump Concrete	1	1	ISL	26MAR95 07:00	26MAR95 07:59	Pump Concrete																				
244	Cure Concrete	9	9	ISL	26MAR95 09:00	26MAR95 17:59	Cure Concrete																				
245	Strip Forms	1	1	ISL	26MAR95 17:00	26MAR95 17:59	Strip Forms																				
250	Set Forms	1	1	CRB	26MAR95 05:00	26MAR95 05:59	Set Forms																				
251	Pump Concrete	2	2	CRB	26MAR95 08:00	26MAR95 09:59	Pump Concrete																				
252	Cure Concrete	9	9	CRB	26MAR95 10:00	26MAR95 18:59	Cure Concrete																				
253	Strip Forms	1	1	CRB	26MAR95 19:00	26MAR95 19:59	Strip Forms																				
260	Final Saw Cut 1"	3	3	ALL	26MAR95 06:00	26MAR95 08:59	Final Saw Cut 1"																				
270	Open Intersection	0	0	ALL	26MAR95 20:00	26MAR95 19:59	Open Intersection																				

Figure E-2  
Proposed Construction Schedule for Chasewood Intersection  
(2 of 2)



Table E-1  
Vibrating Screed Cost Estimate

Dur (hrs)	Description	Qt	\$/sy	\$H.lbs	Unit Cost \$/cy	\$/hr	\$/lf	Mat'l	Total Equip	Labor	Total
8	Demolition/Exc (cy)	440			\$ 10.00						\$ 4,397.00
	Dozer	1				\$ 60.00			\$ 480.00		
	Backhoe	1				\$ 60.00			\$ 480.00		
	Breaker	1				\$ 60.00			\$ 480.00		
	Dump Trucks	4				\$ 35.00			\$ 1,120.00		
	Crew	7				\$ 15.00			\$ 840.00		\$ 4,397.00
1	Proof Rolling	1439									
	Compactor	1				\$ 60.00			\$ 60.00		\$ 60.00
	Crew	3				\$ 15.00				\$ 45.00	\$ 45.00
											\$ 105.00
8	Tie Steel (100 Lbs)	504		\$18.00				\$ 9,065.00			\$ 9,065.00
	All Strips Crew	5				\$ 15.00				\$1,200.00	\$ 1,200.00
											\$10,265.00
10	Set Forms and Strip	1439	\$ 1.00					\$ 1,439.00			\$ 1,439.00
	All Strips Crew	2				\$ 15.00				\$1,500.00	\$ 1,500.00
											\$ 2,939.00
3	11" RC Pavement (cy)	440			\$ 50.00			\$21,983.00			\$ 21,983.00
	Strips 1&3 Crew	6				\$ 15.00				\$ 540.00	\$ 540.00
4	Strips 2&4 Crew	6				\$ 15.00				\$ 720.00	\$ 720.00
											\$23,243.00
2	Island (cy)	27			\$ 45.00			\$ 1,215.00			\$ 1,215.00
	Steel Crew	2				\$ 15.00				\$ 60.00	\$ 60.00
2	Form Crew	2				\$ 15.00				\$ 60.00	\$ 60.00
1	Pouring Crew	3				\$ 15.00				\$ 45.00	\$ 45.00
											\$ 1,380.00
3	Curbs (lf)	300					\$2.00	\$ 600.00			\$ 600.00
	Crew	4				\$ 15.00				\$ 180.00	\$ 180.00
											\$ 780.00

\*Include Material, Labor, and Equipment

	\$ 43,109.00
Contingency	\$ 4,311.00
OH&P	\$ 4,742.00
	\$ 52,161.00

Figure E-3

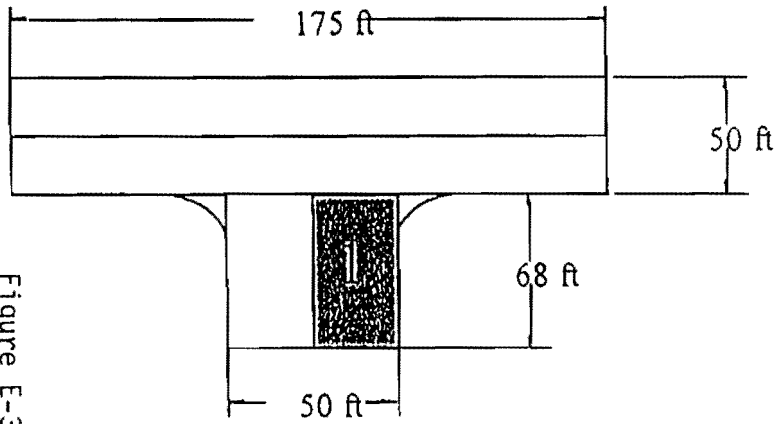

1st Pour Section

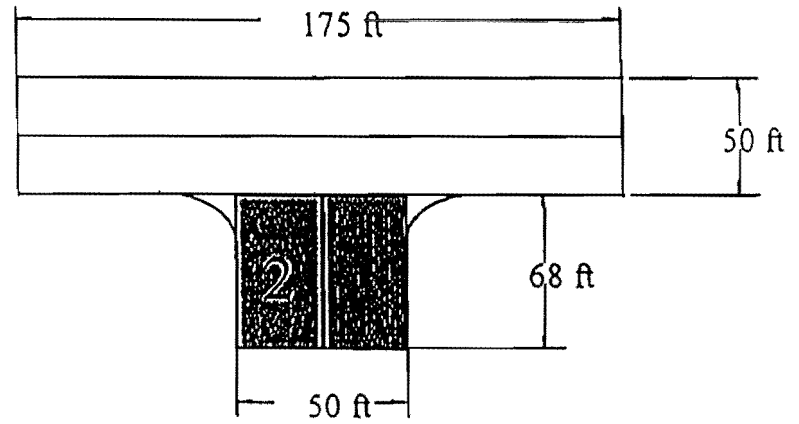

2nd Pour Section

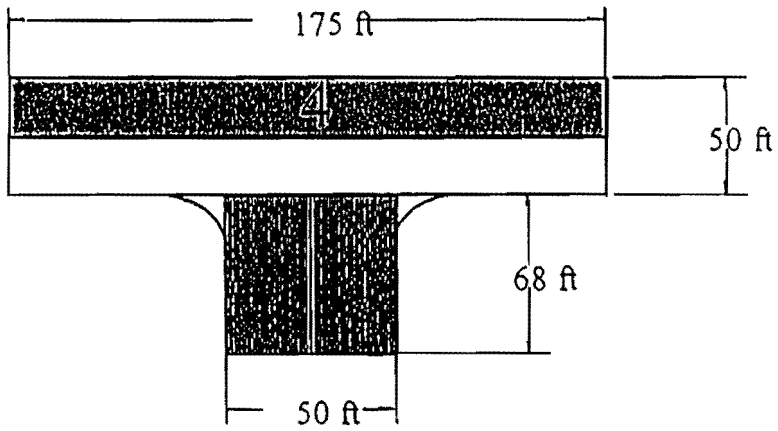

3rd Pour Section

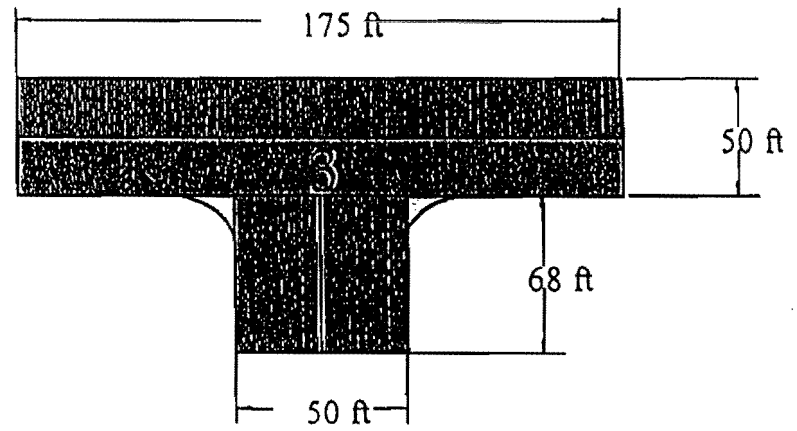

4th Pour Section

 Current Pour Section       Previously Poured Section

Table E-2  
Chasewood Cost Estimate -Contractor

<b>Labor</b>					<b>Total</b>
<b>Description</b>	<b>Quantity</b>	<b>Unit</b>	<b>Rate</b>	<b>Total</b>	
Straight Time Paving Labor	1697	SY	\$ 8.00	\$ 13,576.00	
Grade Subgrade	1697	SY	\$ 0.94	\$ 1,595.18	
Overtime	1697	SY	\$ 4.47	\$ 7,585.59	
Total Direct Labor				\$ 22,756.77	
Labor Burden			55%	\$ 12,516.22	
Contract Fee			25%	\$ 5,689.19	
<b>Total Labor</b>					
<b>Material</b>					
<b>Description</b>	<b>Quantity</b>	<b>Unit</b>	<b>Rate</b>	<b>Total</b>	
Concrete	602	CY	\$ 72.50	\$ 43,645.00	
Reinforcing Steel	595	CWt	\$ 17.75	\$ 10,561.25	
Embedded Materials	1697	SY	\$ 0.35	\$ 593.95	
Screwbars, Dowels, etc.	1697	SY	\$ 0.47	\$ 797.59	
Cotton Curing Mats	150	Ea	\$ 23.00	\$ 3,450.00	
Total Materials				\$ 59,047.79	
Contract Fee			25%	\$ 14,761.95	
<b>Total Materials</b>					<b>\$ 73,809.74</b>
<b>Equipment</b>					
<b>Description</b>	<b>Quantity</b>	<b>Unit</b>	<b>Rate</b>	<b>Total</b>	
Equipment Charge Off	1697	SY	\$ 1.50	\$ 2,545.50	
Equipment				\$ 2,545.50	
Contract Fee			15%	\$ 381.83	
<b>Total Equipment</b>					<b>\$ 2,927.33</b>
<b>Subcontracts</b>					
<b>Description</b>	<b>Quantity</b>	<b>Unit</b>	<b>Rate</b>	<b>Total</b>	
Tie Reinforcing Steel	595	CWt	\$ 6.00	\$ 3,570.00	
Extra Signs & Barricades	1	LS	\$500.00	\$ 500.00	
Pump Concrete	502	CY	\$ 5.00	\$ 2,510.00	
Saw and Seal Joints	1697	SY	\$ 0.47	\$ 797.59	
Police Officer	54	Hr	\$ 16.00	\$ 864.00	
Total Subs				\$ 8,241.59	
Contract Fee			25%	\$ 2,060.40	
<b>Total Subcontracts</b>					<b>\$ 10,301.99</b>
Bond			1%	\$ 1,280.01	\$ 1,280.01
<b>Total Project Cost</b>		LS			<b>\$129,281.25</b>
		SY			<b>\$ 76.18</b>

149

Activity ID	Activity Description	Orig Dur	Rem Dur	%	Early Start	Early Finish	MAR																														
							16	17	18	19	20	21	22	23	0	1	2	3	4	5	6	7	8	9	10	11	12	13	14	15	16	17	18	19	20	21	22
100	PLACE BARRICADES FOR CHWD CLOSURE	1	1	0	15MAR96 18:00	15MAR96 18:59	▶ PLACE BARRICADES FOR CHWD CLOSURE																														
200	DEMO CHWD CONC, ASPH & BASE	2	2	0	15MAR96 19:00	15MAR96 20:59	▶ DEMO CHWD CONC, ASPH & BASE																														
300	REMOVE CONC, ASPH & BASE AREA 1&2	2	2	0	15MAR96 21:00	15MAR96 22:59	▶ REMOVE CONC, ASPH & BASE AREA 1&2																														
500	FINE GRADE AREA 1&2	2	2	0	15MAR96 23:00	16MAR96 00:59	▶ FINE GRADE AREA 1&2																														
400	REMOVE ASPH & BASE AREA 3 & 4	2	2	0	15MAR96 23:00	16MAR96 00:59	▶ REMOVE ASPH & BASE AREA 3 & 4																														
600	SET FORMS FOR AREA 1	2	2	0	16MAR96 01:00	16MAR96 02:59	▶ SET FORMS FOR AREA 1																														
525	FINE GRADE AREA 3&4	2	2	0	16MAR96 01:00	16MAR96 02:59	▶ FINE GRADE AREA 3&4																														
700	SET FORMS FOR AREA 2	2	2	0	16MAR96 03:00	16MAR96 04:59	▶ SET FORMS FOR AREA 2																														
900	PLACE AND TIE REINF STEEL FOR AREA 1	2	2	0	16MAR96 03:00	16MAR96 04:59	▶ PLACE AND TIE REINF STEEL FOR AREA 1																														
800	SET FORMS FOR AREA 4	4	4	0	16MAR96 05:00	16MAR96 08:59	▶ SET FORMS FOR AREA 4																														
1000	PLACE AND TIE REINF STEEL FOR AREA 2	2	2	0	16MAR96 05:00	16MAR96 06:59	▶ PLACE AND TIE REINF STEEL FOR AREA 2																														
2000	PLACE CONCRETE AREA 1	2	2	0	16MAR96 07:00*	16MAR96 08:59	▶ PLACE CONCRETE AREA 1																														
2100	PLACE CONCRETE AREA 2	2	2	0	16MAR96 09:00	16MAR96 10:59	▶ PLACE CONCRETE AREA 2																														
1100	PLACE AND TIE REINF STEEL FOR AREA 4	3	3	0	16MAR96 09:00	16MAR96 11:59	▶ PLACE AND TIE REINF STEEL FOR AREA 4																														
2010	CURE CONCRETE FOR AREA 1	16	16	0	16MAR96 09:00	17MAR96 00:59	▶ CURE CONCRETE FOR AREA 1																														
2110	CURE CONCRETE FOR AREA 2	16	16	0	16MAR96 11:00	17MAR96 02:59	▶ CURE CONCRETE FOR AREA 2																														
2200	PLACE CONCRETE AREA 4	3	3	0	16MAR96 12:00	16MAR96 14:59	▶ PLACE CONCRETE AREA 4																														
2600	REMOVE FORMS AREA 1	1	1	0	16MAR96 13:00	16MAR96 13:59	▶ REMOVE FORMS AREA 1																														
810	SET FORMS FOR AREA 1-R	1	1	0	16MAR96 14:00	16MAR96 14:59	▶ SET FORMS FOR AREA 1-R																														
1200	PLACE AND TIE REINF STEEL FOR AREA 1-R	1	1	0	16MAR96 15:00	16MAR96 15:59	▶ PLACE AND TIE REINF STEEL FOR AREA 1-R																														
2610	REMOVE FORMS AREA 2	1	1	0	16MAR96 15:00	16MAR96 15:59	▶ REMOVE FORMS AREA 2																														

Project Start	16MAR96 18:00	▶ Early Bar
Project Finish	16MAR96 06:59	▶ Final Bar
Date Date	16MAR96 18:00	▶ Progress Bar
Plat Date	16MAR96 12:00	▶ Critical Activity

Figure E-4  
Actual Construction Schedule for Chasewood Intersection

150

Activity ID	Activity Description	Orig Dur	Rem Dur	%	Early Start	Early Finish	MAR									
							16	17	18	19	20	21	22	23	24	25
2210	CURE CONCRETE FOR AREA 4	16	16	0	16MAR96 15:00	17MAR96 06:59	▼CURE CONCRETE FOR AREA 4									
820	SET FORMS FOR AREA 2-R	1	1	0	16MAR96 16:00	16MAR96 16:59	▼SET FORMS FOR AREA 2-R									
2300	PLACE CONCRETE AREA 1-R	1	1	0	16MAR96 16:00	16MAR96 16:59	▼PLACE CONCRETE AREA 1-R									
1210	PLACE AND TIE REINF STEEL FOR AREA 2-R	1	1	0	16MAR96 17:00	16MAR96 17:59	▼PLACE AND TIE REINF STEEL FOR AREA 2-R									
2310	CURE CONCRETE FOR AREA 1-R	16	16	0	16MAR96 17:00	17MAR96 08:59	▼CURE CONCRETE FOR AREA 1-R									
2400	PLACE CONCRETE AREA 2-R	1	1	0	16MAR96 18:00	16MAR96 18:59	▼PLACE CONCRETE AREA 2-R									
2620	REMOVE FORMS AREA 4	2	2	0	16MAR96 19:00	17MAR96 04:59	▼REMOVE FORMS AREA 4									
3000	Saw Concrete Pav. area 1,2&4	1	1	0	16MAR96 19:00	16MAR96 19:59	▼Saw Concrete Pav. area 1,2&4									
2410	CURE CONCRETE AREA 2-R	16	16	0	16MAR96 19:00	17MAR96 10:59	▼CURE CONCRETE AREA 2-R									
2630	REMOVE FORMS AREA 1-R	1	1	0	17MAR96 05:00	17MAR96 05:59	▼REMOVE FORMS AREA 1-R									
2625	Construct Tie-in from Area 4 to SH249	2	2	0	17MAR96 05:00	17MAR96 06:59	▼Construct Tie-In from Area 4 to SH249									
2640	REMOVE FORMS AREA 2-R	1	1	0	17MAR96 07:00	17MAR96 07:59	▼REMOVE FORMS AREA 2-R									
530	REGRADE AREA 3 (IF NEEDED)	1	1	0	17MAR96 08:00	17MAR96 08:59	▼REGRADE AREA 3 (IF NEEDED)									
850	SET FORMS FOR AREA 3	0	0	0	17MAR96 09:00	17MAR96 08:59	▼SET FORMS FOR AREA 3									
1250	PLACE AND TIE REINF STEEL FOR AREA 3	2	2	0	17MAR96 09:00	17MAR96 10:59	▼PLACE AND TIE REINF STEEL FOR AREA 3									
2500	PLACE CONCRETE AREA 3	3	3	0	17MAR96 11:00	17MAR96 13:59	▼PLACE CONCRETE AREA 3									
2510	CURE CONCRETE AREA 3	16	16	0	17MAR96 14:00	18MAR96 05:59	▼CURE CONCRETE AREA 3									
5000	OPEN CHWD TO TRAFFIC	0	0	0	18MAR96 06:00	18MAR96 05:59	▼OPEN CHWD TO TRAFFIC									

Figure E-4  
 Actual Construction Schedule for Chasewood Intersection  
 (2 of 2)

Table E-3  
Actual Operations and Durations

Activity	Description	Start (hours)	Finish (hours)	Duration (hours)	Actual Start (hours)	Actual Finish (hours)	Actual Duration (hours)
100	place barr	0	1	1	0.0	0.1	0.1
200	demo conc	1	3	2	0.1	1.8	1.6
300	remove 1&2	3	5	2	0.8	2.0	1.2
400	remove 3&4	5	7	2	1.0	7.7	6.7
500	fine grade 1&2	5	7	2	5.3	7.9	2.6
525	fine grade 3&4	7	9	2	7.2	10.0	2.8
600	forms 1	7	9	2	7.1	9.3	2.2
700	forms 2	9	11	2	7.9	9.3	1.5
900	steel 1	9	11	2	10.2	11.0	0.8
800	forms 4	11	15	4	10.8	12.7	1.9
1000	steel 2	11	15	4	10.8	12.0	1.3
2000	pour 1	13	15	2	13.6	15.1	1.5
1100	steel 4	15	18	3	11.5	13.3	1.8
2010	cure 1	15	31	16	13.6	29.6	16.0
2100	pour 2	15	17	2	14.6	15.7	1.1
2110	cure 2	17	33	16	15.0	31.0	16.0
2200	pour 4	18	21	3	15.5	17.5	2.0
2600	strip forms 1	19	20	1	17.7	18.0	0.3
810	forms 1r	20	21	1	10.5	13.5	3.0
1200	steel 1r	21	22	1	18.1	19.1	1.0
2210	cure 4	21	37	16	15.5	31.5	16.0
2610	strip 2	21	22	1	17.9	18.4	0.5
820	forms 2r	22	23	1	15.2	16.4	1.2
2300	pour 1r	22	23	1	19.5	20.3	0.8
1210	steel 2r	23	24	1	18.3	19.1	0.8
2310	cure 1r	23	39	16	19.5	35.5	16.0
2400	pour 2r	24	25	1	20.0	21.0	1.0
2410	cure 2r	25	41	16	20.0	36.0	16.0
2620	strip forms 4	25	27	2	22.0	22.5	0.5
3000	saw area 4	25	26	1	36.8	37.8	1.0
2625	tle in	35	37	2	34.0	35.5	1.5
2630	strip 1r	35	36	1	34.0	34.2	0.2
2640	strip 2r	37	38	1	34.0	34.2	0.2
530	regrade 3	38	39	1	33.0	34.0	1.0
850	forms 3	39	39	0	34.6	35.4	0.8
1250	steel 3	39	41	2	35.5	37.5	2.0
2500	pour 3	41	44	3	37.0	39.3	2.3
2510	cure 3	44	60	16	37.0	47.0	10.0
5000	open	60	60	0	60.0	60.0	0.0

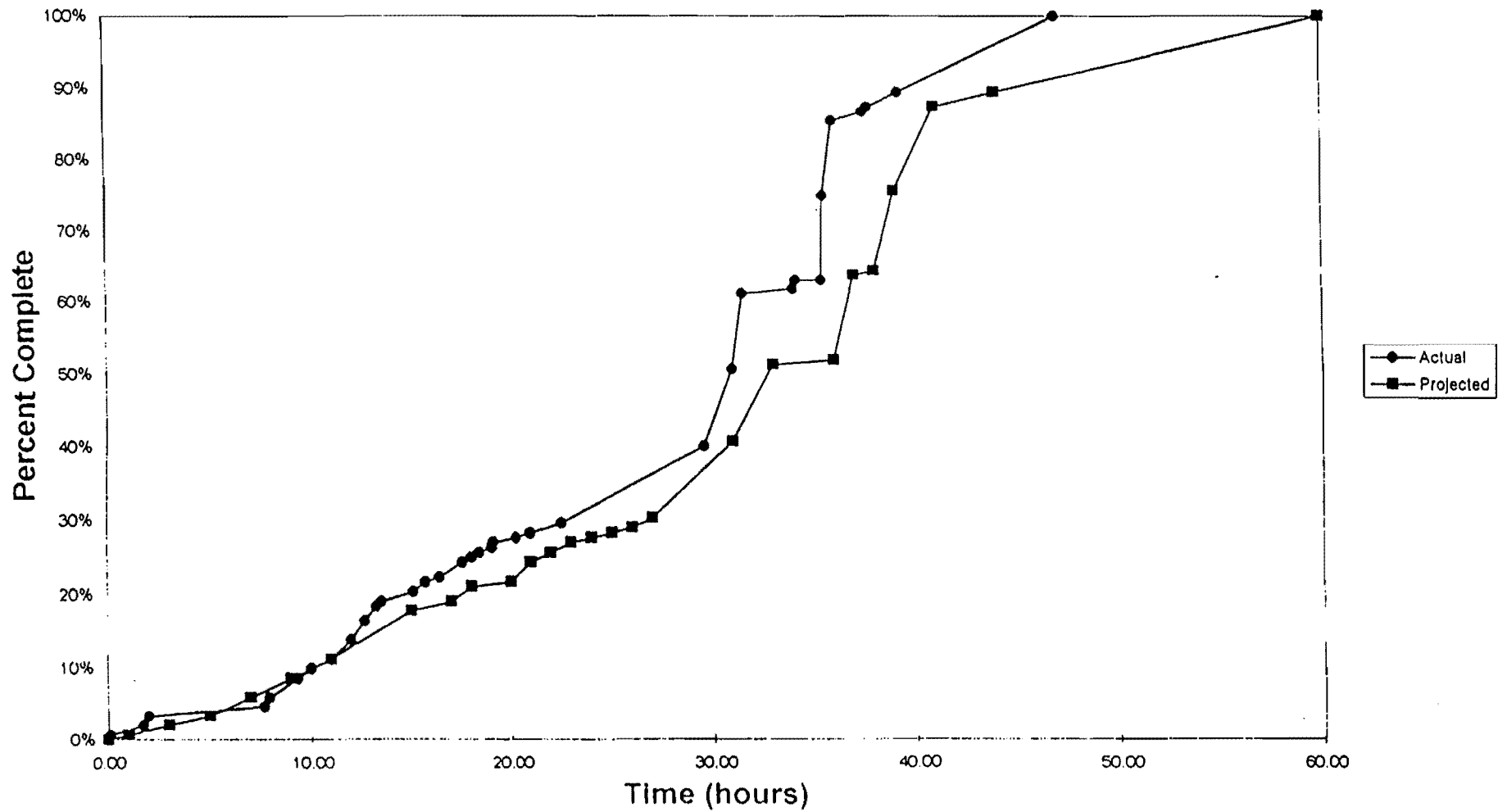

Figure E-5  
Time vs. Percent Complete for  
Actual and Planned Activities

Table E-4  
 Production and Productivity  
 Rates for Chasewood Construction

Crew	Crew Size (men)		Total Duration(min)		Quantity				Production (units/hour)		Productivity (units/manhour)	
	planned	actual	planned	actual	planned		actual		planned	actual	planned	actual
Demo	7	8	540	600	1697		SY 1548		189	155	26.9	19.4
Form	15	13	600	736	1697		SY 1548		170	126	11.3	9.7
Rebar	15	12	780	367	595		Cwt 543		46	89	3.1	7.4
Concrete	10	23	900	483	1697		SY 1548		113	192	11.3	8.4



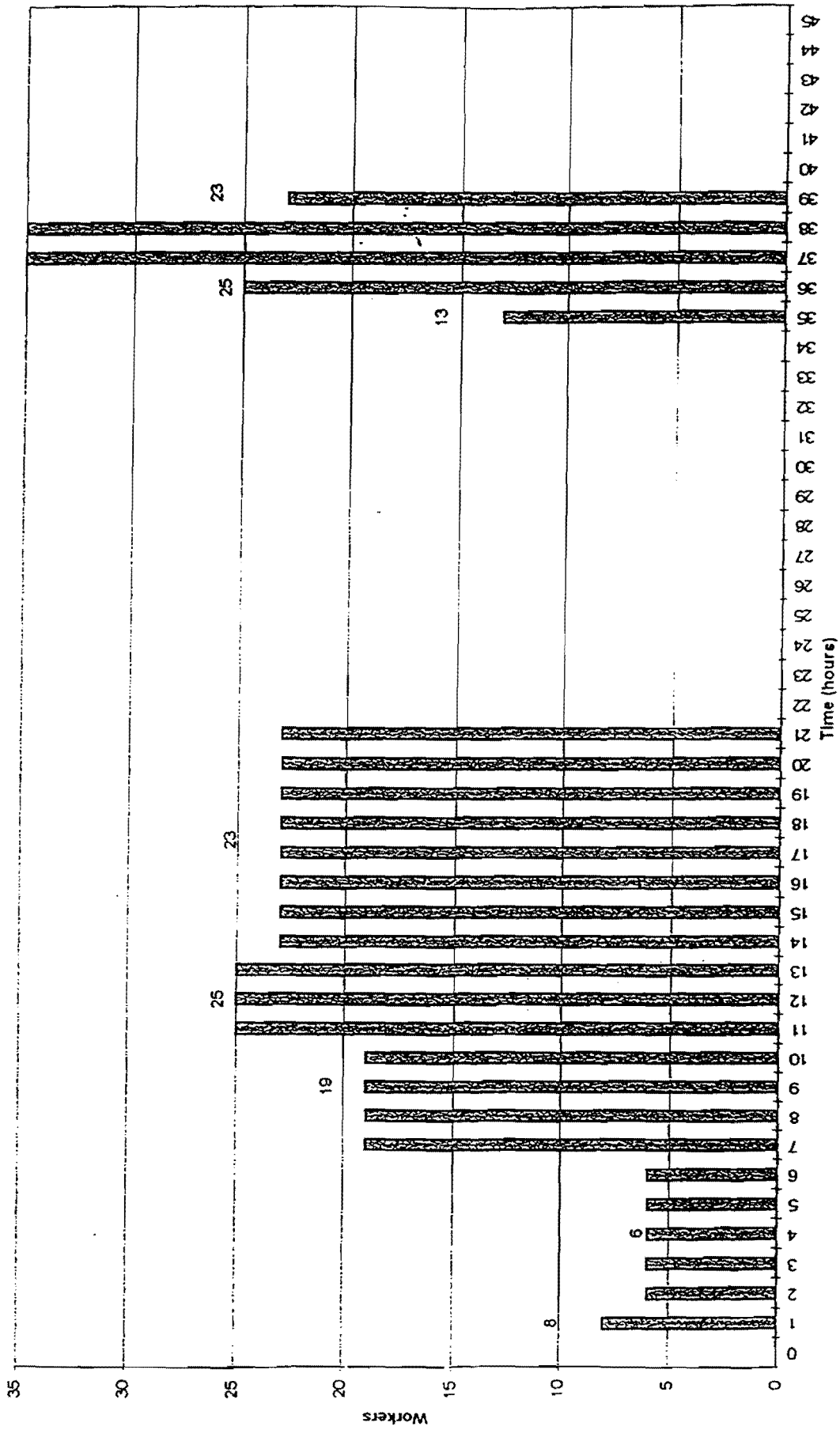

Figure E-6  
 Manpower Profile for  
 Chasewood Intersection

**APPENDIX F:**  
**TIME, TEMPERATURE, AND MATURITY DATA AT THE FIELD**



**Table F-1 Time, Temperature, and Maturity Data for Slab 1**

<b>Time</b>	<b>Temperature (°C)</b>	<b>Maturity (°C-hr)</b>
0:00	19	6
0:30	19.2	20.6
1:00	20.1	35.4
1:30	21.4	51
2:00	22.6	67
2:30	22.4	83
3:00	25.8	100
3:30	26.7	118.1
4:00	26.4	136.4
4:30	26.2	154.6
4:45	27.1	163.8
5:00	28.1	173.2
5:15	29.7	182
5:30	29.6	191.9
5:45	30.2	201.7
6:00	30.4	211.7
6:15	31.1	221.9
6:30	31.6	232.2
6:45	32.2	242.7
7:00	32.8	253.3
7:15	33.4	264.1
7:30	34	275
7:45	33.7	286
8:00	34	297
8:15	34.8	308.1
8:30	35	319.3
8:45	35.3	330.4
9:00	34.6	341.6
9:15	35.4	352.9
9:30	35.4	364.3
9:45	35.5	375.7
10:50	35.1	421
14:00	30.8	560.6
20:10	28.9	806.5
21:20	28.6	851.8
22:00	28	877.5
22:50	27.7	908.9

**Table F-2 Time, Temperature, and Maturity Data for Slab 2**

<b>Time</b>	<b>Temperature (°C)</b>	<b>Maturity (°C-hr)</b>
0:30	20	5
1:00	21	14
1:30	22	30
2:00	22	46
2:30	24	61
3:00	27	79
3:30	28	98
4:00	28	117
4:45	29	147
5:00	32	158
5:15	32	167
5:30	32	178
5:45	34	188
6:00	35	202
6:15	36	211
6:30	37	224
6:45	38	235
7:00	39	247
7:15	40	262
7:30	40	272
7:45	42	284
8:00	42	302
8:15	42	310
8:30	42	324
8:45	43	337
9:00	43	347
9:15	42	366
10:20	43	421
13:30	41	584
19:40	37	875
20:50	35	931
21:30	34	965
22:20	33	997

**Table F-3 Time, Temperature, and Maturity Data for Slab 4**

<b>Time</b>	<b>Temperature (°C)</b>	<b>Maturity (°C-hr)</b>
0:30	22.2	15
1:00	24	32
1:30	25.7	49
2:00	27.3	77
2:30	29	96
2:45	29	110
3:00	30	120
3:15	31	128
3:30	32	138
3:45	32	147
4:00	32	155
4:15	32	167
4:30	32	178
4:45	32	186
5:00	33	200
5:15	33	208
5:30	33	220
5:45	33	230
6:00	34	241
6:15	35	252
6:30	35	264
6:45	34	275
7:00	35	286
7:15	35	296
7:30	34	308
7:45	34	323
8:50	33	373
12:00	31	502
18:10	26	741
19:20	24	780
20:00	24	809
20:50	24	831

**Table F-4 Time, Temperature, and Maturity Data for Slab 3**

<b>Time</b>	<b>Temperature (°C)</b>	<b>Maturity (°C-hr)</b>
9:20	22	31
10:10	24	57
11:30	26	101
12:30	29	138
13:35	34	186
18:30	47	450
19:15	45	487
19:30	45	496
20:20	45	546

**APPENDIX G:**  
**STATISTICAL ANALYSIS OF FIELD DATA**





Statistical tests for evaluating the applicability of laboratory test results at the field:

Intercept  $\beta_0$ :

$$H_0: \beta_{0,lab} = \beta_{0,field}$$

$$H_a: \beta_{0,lab} \neq \beta_{0,field}$$

$$T. S.: t = \frac{\beta_{0,lab} - \beta_{0,field}}{s_\epsilon \sqrt{\frac{\sum x^2}{nS_{xx}}}}$$

where;

$\beta_{0,lab}$  = Intercept of the linear trend line for laboratory Specimens

$\beta_{0,field}$  = Intercept of the linear trend line for field Specimens

$\beta_{1,lab}$  = Slope of the linear trend line for laboratory Specimens

$\beta_{1,field}$  = Slope of the linear trend line for field Specimens

$$s_\epsilon = \sqrt{\frac{S_{yy} - \beta_{1,lab}S_{xy}}{n-2}}$$

$$S_{xx} = \sum x^2 - \frac{(\sum x)^2}{n}$$

$$S_{xy} = \sum xy - \frac{\sum x \sum y}{n}$$

R. R.: For 99% confidence interval and  $df = n-2 = 5$ ;

Reject  $H_0$  if  $|t| > t_{0.005}$

$$t = 3.77799 \text{ and } t_{0.005} = 4.032$$

Conclusion: Fail to reject  $H_0$

and

$$H_0: \beta_{0,field} = \beta_{0,lab}$$

$$H_a: \beta_{0,field} \neq \beta_{0,lab}$$

$$T. S.: t = \frac{\beta_{0,field} - \beta_{0,lab}}{s_\epsilon \sqrt{\frac{\sum x^2}{nS_{xx}}}}$$

where;

$$s_\epsilon = \sqrt{\frac{S_{yy} - \beta_{1,field}S_{xy}}{n-2}}$$

R. R.: For 99% confidence interval and  $df = n-2 = 1$ ;

Reject  $H_0$  if  $|t| > t_{0.005}$

$$t = -0.70177 \text{ and } t_{0.005} = 63.657$$

Conclusion: Fail to reject  $H_0$

Likewise the same test was done for slope values:

Slope  $\beta_1$ :

$$H_0: \beta_{1,lab} = \beta_{1,field}$$

$$H_a: \beta_{1,lab} \neq \beta_{1,field}$$

$$T. S.: t = \frac{\beta_{1,lab} - \beta_{1,field}}{\frac{s_\epsilon}{\sqrt{S_{xx}}}}$$

where;

$$s_{\varepsilon} = \sqrt{\frac{S_{yy} - \beta_{1,lab} S_{xy}}{n-2}}$$

R. R.: For 99% confidence interval and  $df = n-2 = 5$ ;

Reject  $H_0$  if  $|t| > t_{0.005}$

$$t = 4.009317 \text{ and } t_{0.005} = 4.032$$

Conclusion: Fail to reject  $H_0$

and

$$H_0: \beta_{1,field} = \beta_{1,lab}$$

$$H_a: \beta_{1,field} \neq \beta_{1,lab}$$

$$T. S.: t = \frac{\beta_{1,field} - \beta_{1,lab}}{\frac{s_{\varepsilon}}{\sqrt{S_{xx}}}}$$

where;

$$s_{\varepsilon} = \sqrt{\frac{S_{yy} - \beta_{field} S_{xy}}{n-2}}$$

R. R.: For 90% confidence interval and  $df = n-2 = 1$ ;

Reject  $H_0$  if  $|t| > t_{0.005}$

$$t = 0.708757 \text{ and } t_{0.005} = 63.657$$

Conclusion: Fail to reject  $H_0$

**APPENDIX H:**  
**CONCRETE TEMPERATURE SIMULATION**



**Table H-1 Temperature-Time Values Estimated by Simulation Program for Slabs 1,2, and 4**

<b>Time (hr)</b>	<b>Temperature(°C)</b>
0	21.9
1	21.9
2	24.6
3	28.0
4	31.5
5	33.6
6	34.6
7	35.0
8	34.8
9	34.2
10	33.5
11	33.2
12	33.0
13	32.8
14	32.8
15	32.7
16	32.6
17	32.5
18	32.4
19	32.4
20	32.3
21	32.1
22	32.0
23	31.9
24	31.8

**Table H-2 Temperature-Time Values Estimated by Simulation Program for Slab 3**

<b>Time (hr)</b>	<b>Temperature(°C)</b>
0	22.8
1	22.8
2	26.0
3	30.4
4	35.0
5	37.6
6	38.8
7	39.1
8	38.7
9	37.7
10	36.5
11	35.8
12	35.3
13	35.0
14	34.8
15	34.6
16	34.4
17	34.3
18	34.1
19	34.0
20	33.8
21	33.7
22	33.5
23	33.4
24	33.2

**APPENDIX I:**  
**72 HOUR URBAN INTERSECTION RECONSTRUCTION**  
**GUIDELINES**





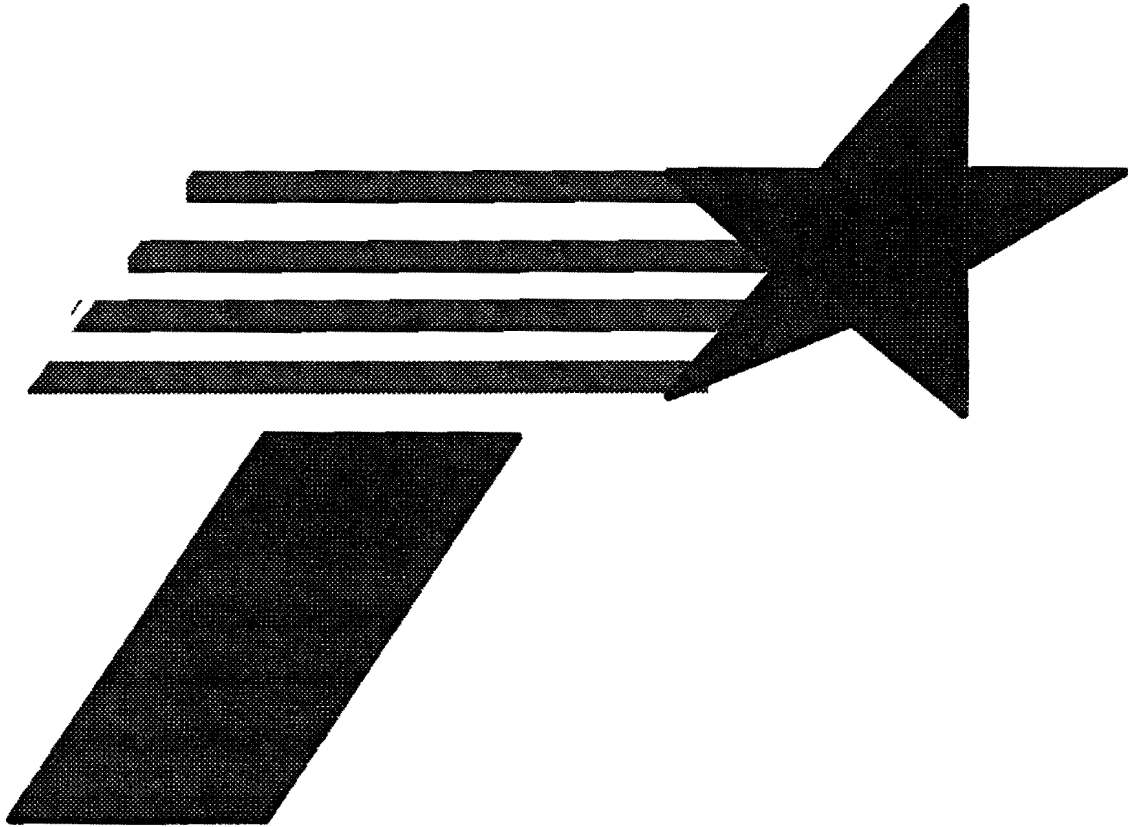

72 Hour Urban  
Highway Intersection  
Reconstruction  
Guidelines



# TABLE OF CONTENTS

<b>PREFACE</b> .....	<b>4</b>
<b>PLANNING</b> .....	<b>7</b>
STEP 1: FORM DESIGN TEAM .....	7
STEP 2: PRE-EVALUATE INTERSECTION .....	11
<b>DESIGN</b> .....	<b>15</b>
STEP 3: DEVELOP PRELIMINARY DESIGN DATA .....	15
STEP 4: PERFORM CONSTRUCTABILITY ANALYSIS .....	19
STEP 5: EVALUATE INTERSECTION .....	25
STEP 6: FINALIZE DESIGN DOCUMENTS .....	27
<b>CONTRACTOR INTERACTION</b> .....	<b>31</b>
STEP 7: FORM CONSTRUCTION TEAM.....	31
STEP 8: REVIEW CONTRACTOR PLAN .....	33
STEP 9: QUALIFY MIX DESIGN .....	35
<b>CONSTRUCTION</b> .....	<b>37</b>
STEP 10: MONITOR CONSTRUCTION OPERATIONS .....	37
STEP 11: PERFORM MATERIALS MANAGEMENT .....	41

## PREFACE

The 72 hour intersection reconstruction guidelines are a set of steps to assist TxDOT with the accelerated reconstruction of intersections. The guidelines provide TxDOT with a structured framework for proper implementation of the 72 hour intersection reconstruction process. The guidelines consist of 11 steps that describe four major phases of the intersection reconstruction project life. These four phases are: Planning, Design, Contractor Interaction, and Construction. Figure 1 displays the process model the guidelines describe.

Each guideline step is divided into eight major headings. These headings represent different aspects of each step. These headings are defined below.

**OBJECTIVE:** outlines the step and identifies the problem to solve

**WHO:** identifies the primary person who will be performing the operations; Identifies secondary personnel as well as outside help that can be utilized to complete the operation

**ACTIONS:** a itemized list of each task that must be performed in order to complete the step

**INFORMATION NEEDED:** identifies the data needed to be obtained in order to perform the step

**ISSUES TO CONSIDER:** identifies possible problems, risks and tips that could benefit the step

**CONSTRAINTS:** those items that restrict or limits the step

**RESOURCES AND TOOLS:** a source of supply, support, or aid - can be people, books, procedures or methods

**OUTPUTS:** objects or data produced as a result of performing the step.

The 72 hour intersection reconstruction guideline steps are set up to provide the engineer with the direction needed to successfully complete each step. The guidelines are by no means “all the information needed” to perform each step. These guidelines armerey a structure of events to follow and ideas that will allow an engineer to produce successful results.

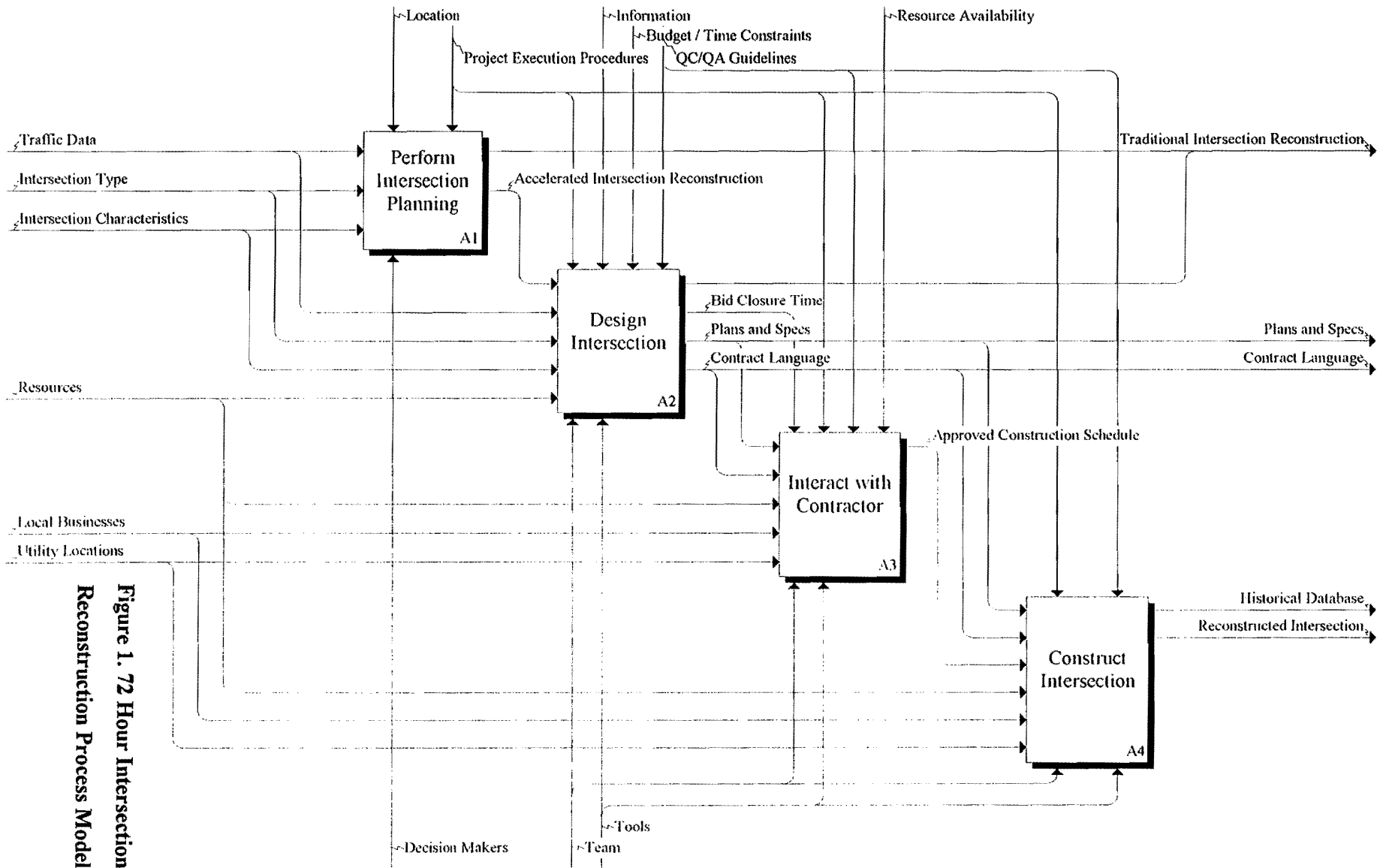

**Figure 1. 72 Hour Intersection Reconstruction Process Model**



# PLANNING

## Step 1: Form Design Team

### WHO:

- TxDOT district management
- Design team leader

### OBJECTIVE:

- To form a design team with the proper mix of expertise and skills to evaluate and design intersections using the 72 hour reconstruction process
- To determine expertise and skills required for each team member

### ACTIONS:

- Identify and assign design team leader
- Determine expertise and skills needed for each member
- Identify possible candidates
- Assign members
- Determine the duties and responsibilities of each member

### INFORMATION NEEDED:

- Location of intersection
  - ✓ Leader should come from nearest district or area office
  - ✓ Locations of possible design team members - district or area office
- Intersection characteristics
  - ✓ Type of skills and experience needed
  - ✓ Potential level of involvement required

### ISSUES TO CONSIDER:

- *Team Leader Expertise*
  - ✓ Project management background
  - ✓ Well developed leadership skills
  - ✓ Broad range of technical expertise
  - ✓ Experience with teamwork approach



- *Transportation Engineer Expertise*
  - ✓ May or may not be the same person who designs the geometrics. If it is not the same person, then the person who designs the geometrics should be available for consultation.
  - ✓ May include one or more of the following people:
    - District Traffic Engineer
    - Assistant District Traffic Engineer
    - District Traffic Safety Specialist
    - District Traffic Operations Manager
    - Representative from Traffic Operations Division (Central Office, Austin)
    - Area Engineer
  
- *Material Engineer Expertise*
  - ✓ Ability to select pavement type
  - ✓ Ability to determine cement type
  - ✓ Ability to determine workability requirements in terms of method of placement.
  - ✓ Ability to design geometrics of intersection
  
- *Construction Engineer Expertise*
  - ✓ Construction planning and scheduling
  - ✓ Construction phasing
  - ✓ Construction methods
  - ✓ Cost estimating
  - ✓ Construction simulation
  
- Other Issues
  - ✓ Type of contract - stand alone or part of a larger project
  - ✓ Multiple intersections in one project
  - ✓ Intersection size and complexity
  - ✓ Design in house or performed by consultant
  - ✓ Size of team required
  - ✓ Location of team members

## **CONSTRAINTS:**

- Availability of personnel
- Design performed in house or through consultant

**RESOURCES  
AND TOOLS:**

- TxDOT policies and procedures for assigning personnel to projects
- Past projects
- Team building
- Partnering

**OUTPUTS:**

- Team structure
  - ✓ Team Leader with the desired expertise
  - ✓ Team members with the desired expertise
  - ✓ Consultants that can provide input as necessary
  - ✓ Organizational chart
  - ✓ Roles and responsibilities of team members



# PLANNING

## Step 2: Pre-Evaluate Intersection

### WHO:

#### PRIMARY

- Design Team: Team Leader, Transportation Engineer and Construction Engineer
- TxDOT District Management

#### SECONDARY

- Area Engineers
- AGC
- Consultants
- Austin Central Office Management

### OBJECTIVE:

- To determine if intersection is suited for the 72 hour reconstruction process
- To develop a recommendation for the potential intersection reconstruction
- To determine whether or not to continue 72 hour intersection reconstruction process

### ACTIONS:

- Evaluate transportation related challenges that the intersection poses
- Evaluate construction related challenges that the intersection poses
- Determine suitability of the intersection for 72 hour reconstruction
- Determine whether or not to continue into the design phase of the 72 hour reconstruction process

### INFORMATION

#### NEEDED:

#### TRAFFIC CONTROL

- Traffic volumes for each turning movement
- Type of traffic on the intersecting roadways
  - local, neighborhood
  - collector
  - arterial
- Map of the intersection vicinity (to help in searching possible detour routes)

- Input from affected businesses and residences. This may be gathered informally, from:
  - comments received.
  - by mail-out surveys, or
  - by “door-to-door” surveying
- Input from emergency response personnel
  - fire department
  - police department
  - EMS
- Input from schools about effect on bus routes
- Input from municipal transportation authority, including effect on transit operations
- Input from U.S. Postal Service

CONSTRUCTION

- Dimensions of the intersection
- Location of the intersection
- Access to, from, and around intersection
- Location of major utilities and entrances / exits from businesses impacted

**ISSUES TO CONSIDER:**

TRAFFIC CONTROL

- Accelerated urban intersection replacement requires closing at least one, and possibly all, of the traffic movements through the intersection.
- Generally, the following conditions would eliminate the intersection as a candidate for accelerated construction:
  - ✓ Very high traffic volume
  - ✓ Extremely low traffic volume
  - ✓ Traffic typical of major arterials (i.e., very little neighborhood traffic)
  - ✓ Lack of an acceptable detour route that can be maintained at all times for emergency vehicles
  - ✓ large number of negative responses from affected businesses, residences, and organizations

CONSTRUCTION

- Intersection should be eliminated due to a combination of the following attributes:
  - ✓ Intersection is extremely large - i.e. it is not possible to achieve production rates necessary to support the schedule requirements
  - ✓ Intersection requires a substantial grade change
  - ✓ Access for construction equipment and materials is nonexistent
  - ✓ Immovable obstructions that will hinder proper construction

- ✓ Risk of not completing the reconstruction within the 72 hours is high
- Very few intersections should be eliminated due to construction criteria because there are numerous approaches to solve possible problems discussed above. However, a combination of these problems will probably make it unrealistic to finish construction within the 60 hour time span.

### **CONSTRAINTS:**

- Funds available
- Time of year for reconstruction
- Level of effort required

### **OUTPUTS:**

- Recommendation on the suitability of the intersection for construction using the 72 hour process
  - ✓ Allow the intersection to continue into the design process - This recommendation occurs when the team members agree that the intersection is suitable for the 72 hour process or when there are conflicting assessments on the suitability of the intersection. In the latter case, further development is necessary.
  - ✓ Reject the intersection for reconstruction using the 72 hour reconstruction process - This recommendation occurs when team members unanimously agree that the intersection is poorly suited for the 72 hour process or when there is a strong argument against accelerated intersection reconstruction based on traffic control and construction criteria analyzed.



## DESIGN

### Step 3: Develop Preliminary Design Data

#### WHO:

- Material engineer(s)
- District pavement design engineer(s)
- Transportation engineer(s)

#### OBJECTIVE:

- To develop preliminary pavement design
- To develop preliminary traffic control plan

#### ACTIONS:

##### PRELIMINARY PAVEMENT DESIGN

- Develop preliminary geometrics of intersection
- Determine pavement section
- Formulate initial mix design requirements (materials types and sources)

##### PRELIMINARY TRAFFIC CONTROL PLAN

- Determine the type of closure for traffic control
- Develop a recommendation for traffic control

#### INFORMATION

##### NEEDED:

- Location and size of the intersection
- Configuration of the intersection
- Traffic Volumes
- Traffic Movements
- Area Street Map - for use in determining detour routes
- Location of nearest schools, fire stations, hospitals, and post offices
- Location of existing wazzu utilities
- Location of existing business entrances
- Existing intersection materials
- Materials and pavement related information



## ISSUES TO CONSIDER:

### TRAFFIC CONTROL PLAN

#### Full Closure - Advantages

- Increased room to work
- Less effort required in shifting detour traffic during construction
- Safer for the construction personnel

#### Full Closure - Disadvantages

- Detour route is required
- Longer delays to motorists (compared to keeping traffic movements open)
- Longer response times for emergency vehicles, mail services, and others
- Possible impacts of increased traffic on detour route
- Detour route may not be suitable to handle increased traffic (structurally)

#### Partial Closure - Advantages

- Detour route is not required
- Less delay to motorists
- Faster response time for affected service vehicles
- No impact due to detouring traffic

#### Partial Closure - Disadvantages

- Less room to work
- Less safe for work crews
- Traffic must be shifted several times during the reconstruction

#### Detour Routes

- For a route to be acceptable as a detour route, it should be capable of handling, as a minimum, all emergency response vehicles (police, ambulance, and fire trucks). The detour route should preferably allow emergency vehicles to reach their destination with not more than a ten minute delay. This is not as critical if the destinations can be reached by emergency personnel coming from another location that can arrive in not more than ten minutes longer than would the normal emergency response personnel. The detour does not have to be able to handle automobile traffic, or bus route traffic, if the school and transit authorities have no overwhelming objections.
- Turning radii that will allow for turning movement of largest vehicle type of traffic using the facility
- Neighborhood (proximity of detour to residences, etc.)

- Pavement section (will it handle the traffic loads for the duration of the accelerated reconstruction, and what will it take to restore the detour road surface to its preexisting condition?)

## **CONSTRAINTS:**

- Material constraints
- Existing TxDOT policy on closing a road-

Presently, for a district to close a road as part of a planned construction project requires several things. First, the district must inform all local officials, such as the city, county, police department, fire department, U.S. Postmaster, schools, and so on, of the planned closure and gain their written approval. Such a closure may affect them in many ways including such things as emergency responses, long detours, detour that may need to move heavy traffic onto one of their local city or county streets or others. It is important that entities impacted know and approve of such actions. These approvals from local officials along with a detour map are to be sent to [the Design Division] for review and approval from the Texas Department of Transportation Deputy Executive Director. There is a possibility that this approval may be delegated to the District Engineer, with proper coordination and documentation, in the near future.

## **RESOURCES AND TOOLS:**

- TxDOT procedures on pavement design
- TxDOT procedures and policies for traffic control at intersections
- Former projects using similar closure methods

## **OUTPUTS:**

- Preliminary pavement design
  - ✓ Rough pavement dimensions and geometric data
  - ✓ Type of pavement construction
  - ✓ Type of base materials
  - ✓ Grade profiles
  - ✓ Type of cement
  - ✓ Location of utilities
  - ✓ Range for curing times of concrete mix
- Preliminary traffic control plan with at least the type of closure
- Preliminary signing needs
- List of agencies affected by traffic control



## Step 4: Perform Constructability Analysis

### WHO:

#### PRIMARY

- Construction Engineer

#### SECONDARY

- AGC
- Outside construction consultants

### OBJECTIVE:

- To determine if intersection can be reconstructed in 72 hours or less based on:
  - ✓ Feasible construction method
  - ✓ Preliminary phasing and sequencing plan
  - ✓ Construction schedule
  - ✓ Cost estimate for the proposed intersection
- To identify risks involved
- To provide recommended actions

### ACTIONS:

#### PHASING AND SEQUENCING

- Develop a general plan of how the proposed intersection can be phased and sequenced
- Determine phasing sections
- Evaluate sequence of construction
- Identify main construction activities by phase section
- Confirm sequencing consistent with traffic control plan

#### CONSTRUCTION METHOD

- Identify total amount of units for each phase of construction - demolition (SY), formwork (LF), rebar(Cwt), and concrete placement(SY)
- Determine possible construction methods to achieve desired production rates
- Identify equipment and labor requirements for each method developed
- Identify pros and cons for each method analyzed

### CONSTRUCTION SCHEDULE

- Review overall phasing scheme
- Identify main construction activities
- Determine logical sequence of activities
- Estimate construction durations for each activity
- Calculate construction schedule
- Identify which activities will be critical with regards to maintaining the schedule
- Compare schedule to expected closure time
- Review and revise schedule, as necessary

### COST ANALYSIS

- Determine materials required
- Determine equipment required
- Determine labor requirements
- Estimate durations for crews and equipment
- Estimate costs for labor, materials, equipment, labor burdens, overhead, and profit
- Summarize total estimated cost of construction including contingency

## **INFORMATION NEEDED:**

### PHASING AND SEQUENCING

- Intersection dimensions / configuration
- Preliminary traffic control plan
- Preliminary pavement design data

### CONSTRUCTION METHOD

- Dimensional data for each phase section
- Access for construction equipment
- Locations of nearest batch plants
- Production rates for major activities of each method
- Types of methods available

### CONSTRUCTION SCHEDULE

- Cure rates for concrete mix
- Production rates from historical data
- Production rates from manufacturers
- Construction method chosen
- Construction phasing plan
- Crew sizes
- Crew composition

- Traffic control plan
- Pavement design plan

### COST ANALYSIS

- Production rates
- Intersection dimensions
- Crew sizes
- Crew wage rates
- Equipment unit costs
- Task durations
- Material unit costs

## **ISSUES TO CONSIDER:**

### PHASING AND SEQUENCING

- Safety of workers
- Type of protective barriers required - (Low Profile Concrete Barriers)
- Work Space available
- Equipment storage space available
- Demolition occurring next to fresh concrete pours
- Total phasing of project as a whole
  
- Tips: Full Closure phasing
  - ✓ No constraints due to traffic flow.
  - ✓ Pour widths should fall in lane width intervals
  - ✓ Construction joints should be placed between intersection lanes
  - ✓ Construction joints should be kept to a minimum
  
- Risks with Full closure:
  - ✓ Too wide of a pour causes problems with cracking
  
- Tips: Partial Closure
  - ✓ Phasing must follow traffic flow
  - ✓ All construction operations must be performed on each phase before the next phase begins
  - ✓ Each phase must reach design strength before the next can be started
  
- Risks with partial closure phasing:
  - ✓ Safety of Workers
  - ✓ Placement of protective barriers
  - ✓ Problems with work space
  - ✓ Demolition occurs directly next to new concrete pours
  - ✓ Completing reconstruction within the 60 hour project duration

### CONSTRUCTION METHOD

- Equipment needed
- Crew sizes needed
- Equipment storage
- Locations of nearest batch plants
- Type of screed
- Type of demolition
- Locations of utilities
- Base compositions
- Site congestion
- Storage space for materials
- Grade differences and profile changes
- Location of site for materials removed
- Location of construction joints
- Time needed before forms can be stripped prior to the concrete gaining full strength

### CONSTRUCTION SCHEDULE

- Amount of work space available
- Work tasks can be run simultaneous
- Utilizing multiple crews and equipment
- Main areas of construction: Demolition/Excavation; Formwork, Rebar; Concrete; Cure

### COST ANALYSIS

- Whether or not to include overtime
- Additional cost of admixtures
- Additional cost of material due to after hour batch plant use
- Additional cost of curing mats and polyurethane sheeting
- Cost of imbedded materials

### **CONSTRAINTS:**

- Contractor resources available
  - ✓ Equipment
  - ✓ Batch Plant
  - ✓ Craft Labor
- Construction should begin at 6:00 PM Friday
- Intersection should be re-opened at 6:00 AM Monday
- 60 hours construction duration

## **RESOURCES AND TOOLS:**

### CONSTRUCTION METHOD

- Literature on construction methods
- Past projects
- Outside expertise (AGC, Consultants)

### PHASING AND SEQUENCING

- Literature
- TxDOT procedures/policies for phasing intersections

### CONSTRUCTION SCHEDULE

- Critical path method
  - ✓ Bar Charts
  - ✓ Logic Networks
- Literature on scheduling
- Past projects
- TxDOT procedures/policies for scheduling

### COST ANALYSIS

- Past estimates for material, labor and equipment
- Means manual and other cost database references
- Phone calls to material suppliers, contractors

### GENERAL

- Constructability process
- Meetings
- AGC or outside consultants

## **OUTPUTS:**

- Phasing plan for all proposed traffic control plans
- Best construction method identified
- Logic network base schedule
  - ✓ Bar chart with critical path identified
- Cost estimate for construction





## Step 5: Evaluate Intersection

### WHO:

- Design Team
- TxDOT district management
- Austin central office management

### OBJECTIVE:

- To determine if the intersection can be constructed to design constraints and within allowable time
- To develop a recommendation
- To determine whether or not the intersection can be constructed using the 72 hour reconstruction approach that is recommended

### ACTIONS:

- Design team should meet to evaluate intersection
- Each member of the team should present their evaluation of the intersection as well as a recommendation of whether or not the intersection should continue through the design process
- Team should discuss all aspects of the design phase
- Discuss pros and cons including risks involved
- Develop final recommendation
- Decide to proceed to finalize all design documents based on recommended 72 hour intersection reconstruction approach

### INFORMATION

#### NEEDED:

- Outputs from the preliminary design data
- Output from the constructability analysis
- Intersection characteristics

## ISSUES TO CONSIDER:

- Risks
  - ✓ numerous difficulties with the intersection
  - ✓ Manageable problems
  - ✓ Probability of success and / or failure

## CONSTRAINTS:

- Funds available
- Time of year
- Contractor expertise and availability

## OUTPUTS:

There are three possible recommendations that can be made by the design team:

- The intersection fails to continue through the proposed process - this would occur when the team decides that there are too many problems that would affect the success of the reconstruction ex. Cost, Constructability, Schedule
- The intersection continues through the proposed process - this would occur when the team decides that the majority of the risks associated with the 72 hour construction can be eliminated or managed throughout construction.
- Not enough information is available to make a sound decision - if this is the case, then further preliminary design and constructability analysis should continue until one of the above decisions can be made.
- There are two possible final outputs that should be made at this point in the process
  - ✓ The intersection will be reconstructed using the 72 hour process, and therefore continues into the next step.
  - ✓ The intersection will be reconstructed using a different process, which will terminate any further 72 hour design on the intersection.

## Step 6: Finalize Design Documents

### WHO:

#### PRIMARY

- Material Engineer
- Transportation Engineer
- Construction Engineer

#### SECONDARY

- District Pavement Design Engineer
- TxDOT Transportation Engineers
- Austin central office management
- Outside Construction Consultants
- AGC

### OBJECTIVE:

- To finalize intersection pavement design
- To finalize intersection traffic control plan
- To finalize intersection construction plan

### ACTIONS:

#### PAVEMENT DESIGN

- Finalize pavement thickness and jointing layout
- Finalize mix design for inclusion in bid documents (specifications)
- Finalize all design drawings for intersection

#### CONSTRUCTION PLAN

- Finalize all drawings that will accompany the construction plans in the bid documents (phasing and sequencing plan)
- Develop the final construction method to be included in the contract documents
- Develop the final construction schedule to be included in the contract documents
- Determine the cost range for the construction of the intersection
- Develop schedule of work items and their quantities
- Develop specifications and / or contract language needed to convey construction requirements

TRAFFIC CONTROL PLAN

- Identify any changes from original traffic control plan
- Determine if new traffic control plan meets with TxDOT regulations
- Finalize traffic control plan

**INFORMATION  
NEEDED:**

PAVEMENT DESIGN

- All pavement design inputs required by the AASHTO Guide
- All previous pavement design information
- Traffic levels
- Construction sequencing and traffic phasing plan

CONSTRUCTION PLAN

- Preliminary construction phasing and sequencing plan
- Preliminary construction schedule
- Preliminary construction method
- Preliminary traffic control plan
- Preliminary cost estimate

TRAFFIC CONTROL PLAN

- Contractor traffic control plan

**ISSUES TO  
CONSIDER:**

CONSTRUCTION PLAN

- All plans developed should be bid quality
- All plans need to be reviewed
- Plans should include all necessary information
- Use of incentives / disincentives

TRAFFIC CONTROL PLAN

- TxDOT policies and procedures on traffic control planning

**RESOURCES  
AND TOOLS:**

- TxDOT procedures / policies for pavement design and traffic control

## **OUTPUTS:**

### *PAVEMENT DESIGN*

- A jointing scheme
- A pavement thickness
- Joint details
- Project plans and specifications
- Finalized Mix design

### *CONSTRUCTION PLAN*

- Final construction phasing and sequencing
- Final construction schedule
- Schedule of work items
- Completion time frame
  - ✓ time of year
  - ✓ closure times
- Incentive / Disincentive contract clauses

### *TRAFFIC CONTROL PLAN*

- Revised traffic control plan



# CONTRACTOR INTERACTION

## Step 7: Form Construction Team

### WHO:

- Design Team
- Contractor personnel

### OBJECTIVE:

- To redefine the team that will continue performing the 72 hour intersection reconstruction process
- To determine the responsibilities of the team as well as the team members

### ACTIONS:

- Identify new team members
- Assign new members
- Determine responsibilities of the team and each team member

### INFORMATION

#### NEEDED:

- Contractor personnel
- TxDOT area office personnel
- Resources needed

### ISSUES TO

#### CONSIDER:

- Hierarchy of the team might have to be restructured
- Construction team must be an integrated blend - not merely a TxDOT team and a Contractor team
- Key members that should be added:
  - ✓ Contractor project manager
  - ✓ Contractor field superintendents
  - ✓ TxDOT area engineers
  - ✓ TxDOT inspectors
  - ✓ TxDOT material engineers



**CONSTRAINTS:**

- Availability of contractor personnel
- Availability of TxDOT personnel

**RESOURCES  
AND TOOLS:**

- TxDOT partnering procedure

**OUTPUTS:**

- Revised team structure to include both contractor and TxDOT area personnel
- A list of responsibilities of each team member

# CONTRACTOR INTERACTION

## Step 8: Review Contractor Plan

### WHO:

- Construction Engineer
- Transportation Engineer
- Material Engineer
- Contractor personnel

### OBJECTIVE:

- To determine whether or not changes requested to the original construction plan are acceptable
- To develop contingency plans to minimize the risks of fast-track construction

### ACTIONS:

#### REVIEW CONTRACTOR PLAN

- Identify potential changes to original construction plan
- Determine if the new method will work
- Determine if contract change is required
- Identify problems (if any) for discussion with contractor personnel
- Meet with contractor to review and agree on final construction plan

#### CONTINGENCY PLAN

- Identify areas where problems could arise
- Identify problems that might delay scheduled completion within contract time frame
- Determine the best possible alternative to each problem
- Compile a list of problems and alternative solutions to follow if problems arise during construction

### INFORMATION

#### NEEDED:

#### REVIEW CONTRACTOR PLAN

- Proposed contractor construction method
- Contractor construction phasing and sequencing plan
- Contractor schedule for construction
- Contractor estimate for construction (broken down into divisions)

### CONTINGENCY PLAN

- Weather report for the week of the reconstruction
- Cure rates for the concrete
- Production rates for the project
- Location of utilities
- Location of businesses
- Alternate sources for equipment and materials

## **ISSUES TO CONSIDER:**

### REVIEW CONTRACTOR PLAN

- Potential changes to original plan should be discussed
- Problems if contractor can not meet contract requirements

### CONTINGENCY PLAN

- Poor weather
- Poor Productivity
- Slow Cure Rates of the concrete
- Utility damage
- Equipment breakdown
- Material supply interruptions
- Business entrances blocked

## **RESOURCES AND TOOLS:**

- Previous projects
- Problems with previous projects
- Historical data
- Meetings

## **OUTPUTS:**

- Contractors construction plan
  - ✓ Schedule
  - ✓ Method
- Contingency plans that detail steps to be taken as a result of construction problems

# CONTRACTOR INTERACTION

## Step 9: Qualify Mix Design

### WHO:

- Materials Engineer
- District Pavement Design Engineer

### OBJECTIVE:

- To insure that the mix design will meet the opening and strength requirements

### ACTIONS:

- Conduct time of strength development analysis for various combinations of materials, mixture, and weather conditions.

### INFORMATION

#### NEEDED:

- Type of cement
- Maturity-strength relationships
- Proposed concrete mix proportions
- Type of course aggregate
- Anticipated weather conditions at the time of construction
- Construction methodology and method of curing
- Time limits associated with the placement and hardening of the concrete

### ISSUES TO

#### CONSIDER:

- Strength gain relationships
- Cement and admixture types
- Curing management

### CONSTRAINTS:

- Material availability
- Delivery methods
- Site access

**RESOURCES  
AND TOOLS:**

- Heat of hydration software
- Lab strength results
- Historical weather records

**OUTPUTS:**

- Modified mix proportions
- Method of curing
- Strength-maturity-time relationships
- Time to achieve opening strength

# CONSTRUCTION

## Step 10: Monitor Construction Operations

### WHO:

- Construction Engineer
- Contractor personnel
- Contractor Team
- TxDOT Inspectors

### OBJECTIVE:

- To successfully reconstruct intersection within contract time requirements
- To collect data for future planning and design of 72 hour intersection reconstruction

### ACTIONS:

#### GENERAL

- Establish an historical database for use in later projects
- Determine which operations can be performed prior to construction
- Manage operations that could be completed prior to actual construction
- Inspect the results of any pre-operations completed
- Oversee construction activities during construction
- Determine how well the project is going with respect to schedule
- Identify potential problems before they happen

#### CONSTRUCTION PRE-OPERATIONS

- Compile list of operations that should be completed prior to construction
- Collect data on each operations completed
- Insure contractor performs each operation according to specification

#### DATA COLLECTION

- Identify data needed
- Identify best methods to collect data
- Perform data collection
- Analyze data
- Provide database for future use

### CONSTRUCTION OPERATIONS

- Use data collection as primary means of monitoring operations
- Interpret results from data analysis as quickly as possible
- Use required rates as well as past rates to interpret the way the project is going

## **INFORMATION**

### **NEEDED:**

#### DATA COLLECTION

- Crew size
- Crew composition
- Methods for each activity
- Dimensions of each activity
- Actual quantities for each activity
- Schedule for construction (by operation)
- Cure rate for concrete
- Duration of each operation

#### CONSTRUCTION PRE-OPERATIONS

- Traffic control plan
- Construction phasing and sequencing plan
- Construction schedule
- Site layout with dimensions
- Location of Utilities
- Material Lists
- Equipment Lists
- Checklist with all operations that need to be completed prior to construction

#### CONSTRUCTION OPERATIONS

- Outputs from data collection
- Construction schedule
- Construction material and equipment needed
- Production rates
- Cure rates
- Weather forecast
- Contingency plans

## **ISSUES TO**

### **CONSIDER:**

#### DATA COLLECTION

- Concurrent operations hinder productivity studies
- Operations should be studied one at a time

- Tests should focus on operations that are on the critical path
- Demolition and concrete work are key to obtaining the desired schedule, these two activities should be given special attention

#### CONSTRUCTION PRE-OPERATIONS

- Activities should be limited to those that do not hinder traffic flow for extended periods
  - ✓ saw cutting
  - ✓ removal or replacement of utilities
  - ✓ notification of businesses
  - ✓ stockpiling of resources (materials and equipment)
  - ✓ placing of traffic signs

#### CONSTRUCTION OPERATIONS

- Necessary production rates for success
- Contingency plan initiation
- Required personnel
- Required equipment
- Required materials

### **CONSTRAINTS:**

#### DATA COLLECTION

- Number of observers
- Concurrent construction activities

#### CONSTRUCTION PRE-OPERATIONS

- Time
- Traffic control
- Extent of operation

#### CONSTRUCTION OPERATIONS

- Weather
- Availability of people
- Access to site

### **RESOURCES**

### **AND TOOLS:**

#### DATA COLLECTION

- Production analysis
- Time-start / stop
  - ✓ Efficiency
  - ✓ Quantities placed



- ✓ Hours
- ✓ Activities
- ✓ Sequences
- ✓ Crew sizes / mix
- Video filming
- Observations
- Literature on productivity analysis techniques

#### CONSTRUCTION PRE-OPERATIONS

- Contractor Expertise
- Results from prior projects

#### CONSTRUCTION OPERATIONS

- Past experiences
- Contractor expertise
- TxDOT procedures/policies for contract administration, testing, and inspection
- Database

#### **OUTPUTS:**

- A database with productivity rates
- A site where construction can begin without hindrance
- Completed punchlist with all operations completed
- Determination of how the project is proceeding with relation to the schedule

# CONSTRUCTION

## Step 11: Perform Materials Management

### **WHO:**

- District Construction Engineer
- Help from the materials engineer

### **OBJECTIVE:**

- To layout the QC/QA program for the project

### **ACTIONS:**

- Establish the mixture proportions
- Establish curing methodology, scheduling, and criteria
- Establish expected mixture proportions/curing condition combinations

### **INFORMATION**

#### **NEEDED:**

- Strength-maturity-time relationships
- Opening Strength
- Phasing plan
- Anticipated time of opening

### **ISSUES TO**

#### **CONSIDER:**

- Criteria to be selected relative to curing methodology for a given set of weather conditions
- Time of opening and time of sawcutting

### **CONSTRAINTS:**

- Available curing methods and equipment
- Size of the concrete placement
- Method of concrete placement
- Types of coarse aggregate

## **RESOURCES**

### **AND TOOLS:**

- Maturity/strength gain and temperature analysis software
- Literature on the maturity program

### **OUTPUTS:**

- Testing program
- Curing management plan and contingency plan in case of equipment break downs or unexpected changes in weather