

STUDY OF IN-SERVICE BRIDGES CONSTRUCTED  
WITH PRESTRESSED PANEL SUB-DECKS

by

Harry L. Jones  
Engineering Research Associate

and

Howard L. Furr, P.E.  
Research Engineer

Research Report 145-1

A Study of Prestressed Panels and Composite Action in  
Concrete Bridges Made of Prestressed Beams, Prestressed  
Sub-deck Panels, and Cast-in-place Deck

Research Project No. 2-5-70-145

Sponsored By

The Texas Highway Department  
in Cooperation with  
The U. S. Department of Transportation, Federal Highway Administration

July, 1970

TEXAS TRANSPORTATION INSTITUTE  
Texas A&M University  
College Station, Texas

## ABSTRACT

This report describes the results of a field inspection and load test of three prestressed concrete highway bridges which have a prestressed panel subdeck. The panels, which are precast and pretensioned, span from beam-to-beam and serve as the bottom form for a cast-in-place concrete deck. The bridges examined were located in Grayson County, Texas, and were opened to traffic in August of 1963.

Crack patterns in the surface of the cast-in-place deck of two of the bridges were mapped. With only a few exceptions, the cracks found coincided with a butt joint between prestressed panels. The cracks were judged to extend approximately halfway through the cast-in-place deck. No cracks were found in the prestressed panels. Soundings to detect delamination between prestressed panel and cast-in-place deck were taken in one traffic lane of one of the bridges. No significant delamination was found. Core samples were taken from one span of one bridge, and an examination of these cores revealed no bond failure between panel and cast-in-place deck.

Electrical resistance strain gages were placed on a span of one bridge to measure transverse and longitudinal strains in the prestressed panel and cast-in-place deck. The instrumented span was subjected to both static and dynamic forces from a loaded truck. The results of these tests indicated continuity of action between prestressed beam, panel and cast-in-place deck was present.

## SUMMARY

A recent innovation in prestressed concrete highway bridge construction utilizes prestressed concrete panels as bottom forms for the conventional cast-in-place deck. The precast, prestressed panels are placed on top of the prestressed beams, spanning the distance between adjacent beams. This type of construction is particularly attractive where placement and removal of conventional form work is difficult and costly.

In the design of these bridges, it is assumed that composite action between prestressed beams, prestressed panels and cast-in-place deck is present, causing these three separate elements to act as a unit.

The work reported herein is a field study of three existing highway bridges constructed in 1963 using prestressed concrete panels. The study was undertaken to determine the condition of these structures after seven years of service, and to see if any evidence of a lack of continuity of action between beams, panels and deck could be detected. The study included mapping of crack patterns in the cast-in-place deck, soundings to detect delamination between prestressed panel and cast-in-place deck, corings and load tests.

No evidence of distress or noncomposite action was found in the bridges studied. Some transverse cracking was found in the cast-in-place deck of two of the more heavily traveled structures. With only a few exceptions, the cracks coincided with transverse butt joints

between prestressed panels. Core samples showed these cracks to extend approximately halfway through the cast-in-place deck.

## IMPLEMENTATION STATEMENT

The research effort reported here is only the first phase of a more thorough study to be completed in August of 1971, and therefore, an unqualified statement concerning the implementation of this type of bridge construction would be premature. However, the results of this study indicate that the bridges investigated are performing satisfactorily, and their structural behavior agrees with that assumed in their design.

## TABLE OF CONTENTS

|   | Page |
|---|------|
| I. Introduction . . . . .                       | 1    |
| II. Description of Bridges . . . . .            | 1    |
| III. Inspection of Bridges . . . . .            | 6    |
| IV. Load Tests . . . . .                        | 16   |
| V. Discussion . . . . .                         | 28   |
| VI. Conclusions . . . . .                       | 34   |
| References . . . . .                            | 35   |
| Appendix A. Crack Patterns . . . . .            | 36   |
| Appendix B. Load Test Strain Readings . . . . . | 47   |

The opinions, findings, and conclusions expressed in this report are those of the authors and not necessarily those of the Federal Highway Administration.

LIST OF FIGURES

| Figure |  | Page |
|--------|--|------|
| 1      | St. Louis-San Francisco Railroad Overpasses . . . . .                                  | 3    |
| 2      | Span Layout of St. Louis-San Francisco Railroad<br>Overpasses . . . . .                | 4    |
| 3      | Arrangement of Prestressed Panel, Cast-in-place<br>Slab and Prestressed Beam . . . . . | 5    |
| 4      | Prestressed Panel Layout for 40 ft Span . . . . .                                      | 7    |
| 5      | Prestressed Panel Layout for 50 ft Span . . . . .                                      | 8    |
| 6      | Reinforcing in Cast-in-place Slab . . . . .  | 9    |
| 7      | Typical Prestressed Panel . . . . .  | 10   |
| 8      | Typical Transverse Cracks in Cast-in-place Deck . . . .                                | 12   |
| 9      | Core Sample No. 1 . . . . .  | 14   |
| 10     | Core Sample No. 2 . . . . .  | 14   |
| 11     | Core Sample No. 3 . . . . .  | 15   |
| 12     | Core Sample No. 4 . . . . .  | 15   |
| 13     | Discoloration of Concrete at Crack in<br>Cast-in-place deck . . . . .                  | 17   |
| 14     | Shear Test of Core Sample . . . . .  | 18   |
| 15     | Location of Strain Gage Patterns on Stran 2NB . . . . .                                | 20   |
| 16     | Location of Strain Gages in Pattern No. 1 . . . . .                                    | 21   |
| 17     | Location of Strain Gages in Pattern No. 2 . . . . .                                    | 21   |
| 18     | Typical Strain Gage Installation on Top of<br>Cast-in-place Deck . . . . .             | 22   |
| 19     | Typical Strain Gage Installation on Underside<br>of Prestressed Panels . . . . .       | 22   |

| Figure |  | Page |
|--------|--|------|
| 20     | Location of Strain Gages and Strain Readings<br>in Core Hole No. 1 . . . . .                                   | 23   |
| 21     | Dial Gage Installation to Detect Slippage<br>Between Prestressed Beam and Panel . . . . .                      | 23   |
| 22     | Dial Gage Installation to Detect Relative<br>Displacement Between Two Adjacent Prestressed<br>Panels . . . . . | 24   |
| 23     | Test Vehicle . . . . .   | 26   |
| 24     | Dimensions and Wheel Loads of Test Vehicle . . . . .   | 27   |
| 25     | Position of Test Vehicle for Static and<br>Dynamic Load Tests . . . . .  | 27   |
| 26     | Reference Positions of Test Vehicle Relative<br>to Strain Gage Being Recorded . . . . .                        | 29   |
| 27     | Arrangement of Load and Assumed Transverse Strip<br>for Strain Calculations . . . . .                          | 33   |
| 28     | Transverse Support and Loading Assumptions for<br>Strain Calculations . . . . .                                | 33   |
| A.1    | Cracks in Cast-in-place Deck, Span 1NB . . . . .   | 37   |
| A.2    | Cracks in Cast-in-place Deck, Span 2NB . . . . .   | 38   |
| A.3    | Cracks in Cast-in-place Deck, Span 3NB . . . . .   | 39   |
| A.4    | Cracks in Cast-in-place Deck, Span 4NB . . . . .   | 40   |
| A.5    | Cracks in Cast-in-place Deck, Span 5NB . . . . .   | 41   |
| A.6    | Cracks in Cast-in-place Deck, Span 1SB . . . . .   | 42   |
| A.7    | Cracks in Cast-in-place Deck, Span 2SB . . . . .   | 43   |
| A.8    | Cracks in Cast-in-place Deck, Span 3SB . . . . .   | 44   |
| A.9    | Cracks in Cast-in-place Deck, Span 4SB . . . . .   | 45   |
| A.10   | Cracks in Cast-in-place Deck, Span 5SB . . . . .   | 46   |



| Figure |   | Page |
|--------|---|------|
| B.1    | Strain Readings, Top and Bottom Transverse<br>Gages No. 1, Pattern No. 1 . . . . .    | 48   |
| B.2    | Strain Readings, Top and Bottom Transverse<br>Gages No. 2, Pattern No. 1 . . . . .    | 48   |
| B.3    | Strain Readings, Top and Bottom Transverse<br>Gages No. 3, Pattern No. 1 . . . . .    | 49   |
| B.4    | Strain Readings, Top and Bottom Transverse<br>Gages No. 4, Pattern No. 1 . . . . .    | 49   |
| B.5    | Strain Readings, Top and Bottom Transverse<br>Gages No. 5, Pattern No. 1 . . . . .    | 50   |
| B.6    | Strain Readings, Top and Bottom Longitudinal<br>Stages No. 6, Pattern No. 1 . . . . . | 50   |
| B.7    | Strain Readings, Top and Bottom Longitudinal<br>States No. 7, Pattern No. 1 . . . . . | 51   |
| B.8    | Strain Readings, Bottom Longitudinal Stage No. 8,<br>Pattern No. 1 . . . . .          | 51   |
| B.9    | Strain Readings, Top and Bottom Longitudinal<br>Gages No. 9, Pattern No. 1 . . . . .  | 52   |
| B.10   | Strain Readings, Top and Bottom Longitudinal<br>Gages No. 10, Pattern No. 1 . . . . . | 52   |
| B.11   | Strain Readings, Top and Bottom Transverse Gages<br>No. 1, Pattern No. 2 . . . . .    | 53   |
| B.12   | Strain Readings, Top and Bottom Transverse Gages<br>No. 2, Pattern No. 2 . . . . .    | 53   |
| B.13   | Strain Readings, Top and Bottom Transverse Gages<br>No. 3, Pattern No. 2 . . . . .    | 54   |
| B.14   | Strain Readings, Bottom Transverse Gages<br>No. 4, Pattern No. 2 . . . . .            | 54   |
| B.15   | Strain Readings, Top and Bottom Transverse<br>Gages No. 5, Pattern No. 2 . . . . .    | 55   |
| B.16   | Strain Readings, Top and Bottom Longitudinal<br>Gages No. 6, Pattern No. 2 . . . . .  | 55   |

| Figure |  | Page |
|--------|--|------|
| B.17   | Strain Readings, Top and Bottom Longitudinal<br>Gages No. 7, Pattern No. 2 . . . . . | 56   |
| B.18   | Strain Readings, Top and Bottom Longitudinal<br>Gages No. 8, Pattern No. 2 . . . . . | 56   |
| B.19   | Strain Readings, Top and Bottom Longitudinal<br>Gages No. 9, Pattern No. 2 . . . . . | 57   |

## I. INTRODUCTION

Some of the more recent prestressed concrete highway bridges have incorporated a prestressed panel subdeck into the design. This panel, which is precast and pretensioned, serves as the bottom form for the cast-in-place concrete deck. The elimination of conventional bottom forming for the cast-in-place slab is a major advantage where form placement and removal are difficult and costly.

In the design of these bridges it is assumed that composite action between prestressed beams, prestressed panel and cast-in-place deck is present, causing these three separate elements to act as a unit. This composite action is attained through the bond of the cast-in-place slab to the prestressed panels and beams.

A study is currently underway to determine the behavior of highway bridges constructed with prestressed panels. One phase of this study included a general visual inspection of three existing bridges and a load test of one to see if any evidence of distress or noncomposite action between panel, slab and beam could be detected. This report presents the results of that inspection and load test.

## II. DESCRIPTION OF BRIDGES

The three bridges examined were located in Grayson County, Texas. One is an overpass, carrying Farm Road 902 over U. S. Highway 75, and the other two are parallel structures carrying U. S. Highway 75 over

the St. Louis-San Francisco Railroad. The three overpasses were opened to traffic in August of 1963.

1. Farm Road 902 Overpass: This bridge consisted of four spans; two end spans 45 ft. long and two 60 ft. interior spans. Four Type B prestressed beams, spaced at 6 ft.-8 in. on center, were used in each span. The prestressed panels were 6 ft.-2 in. long, 4 ft.-0 in. wide and 3 in. thick. The panel details and the arrangement of reinforcing in the cast-in-place deck were similar to those used in the St. Louis-San Francisco Railroad overpasses.

2. St. Louis-San Francisco Railroad Overpasses: Figure 1 is a view of the two parallel structures, with the north-bound lane in the foreground. The north-bound and south-bound structures were identical, with each overpass consisting of two 40 ft. end spans and three 50 ft. interior spans as shown in Fig. 2. Six prestressed beams, spaced laterally at 7 ft.-3 in. on center were used in all spans. Type B beams were employed in the two 40 ft. spans, while Type C beams were used in the 50 ft. spans.

The arrangement of prestressed panel, cast-in-place slab and prestressed beam is shown in Fig. 3. Continuity between panels, slab and beams was provided by the bond of the cast-in-place slab to the panels and beams, and by mechanical shear connectors embedded in the upper face of the panels and the top flange of the beams. The prestressed panels rested on continuous fiberboard strips and therefore did not bear directly on the prestressed beams.



Figure 1. St. Louis-San Francisco Railroad Overpasses.

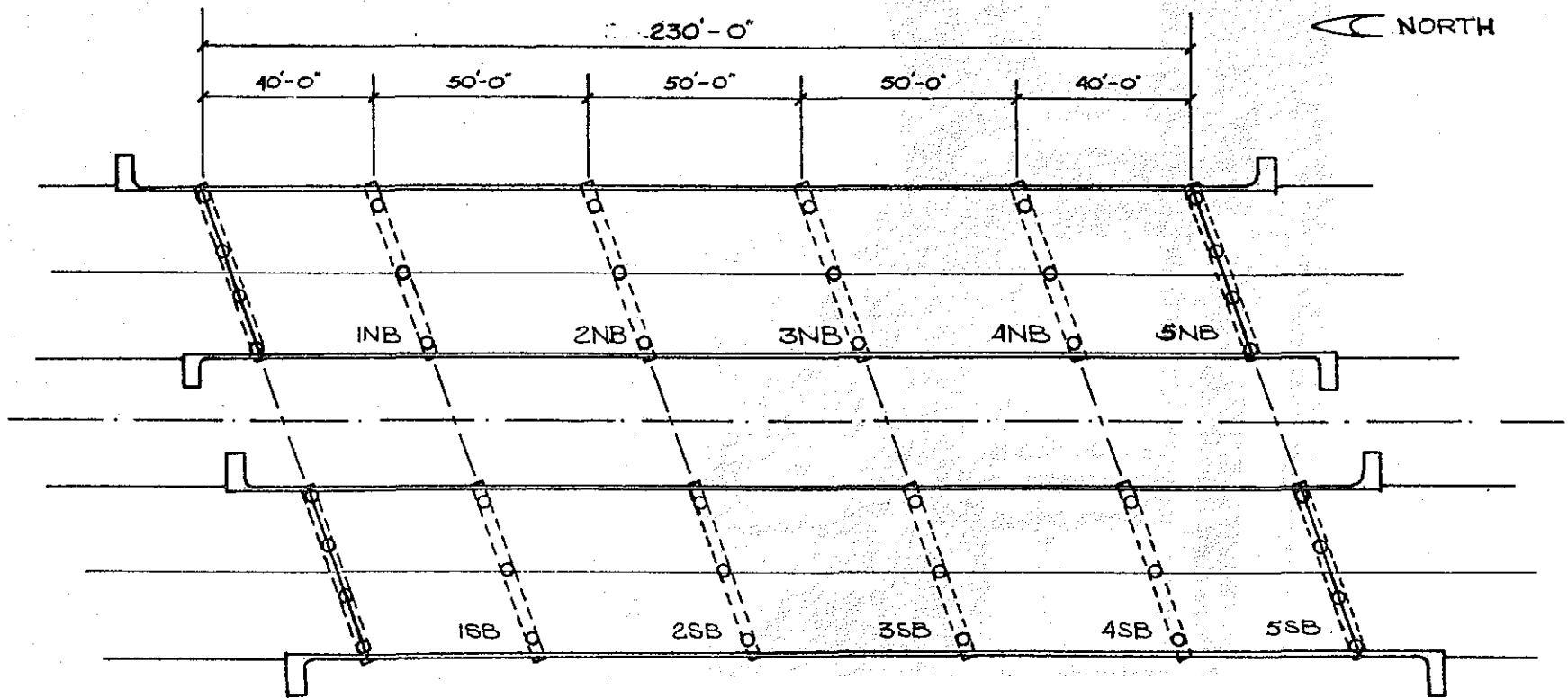

Figure 2. Span Layout of St. Louis-San Francisco Railroad Overpasses.

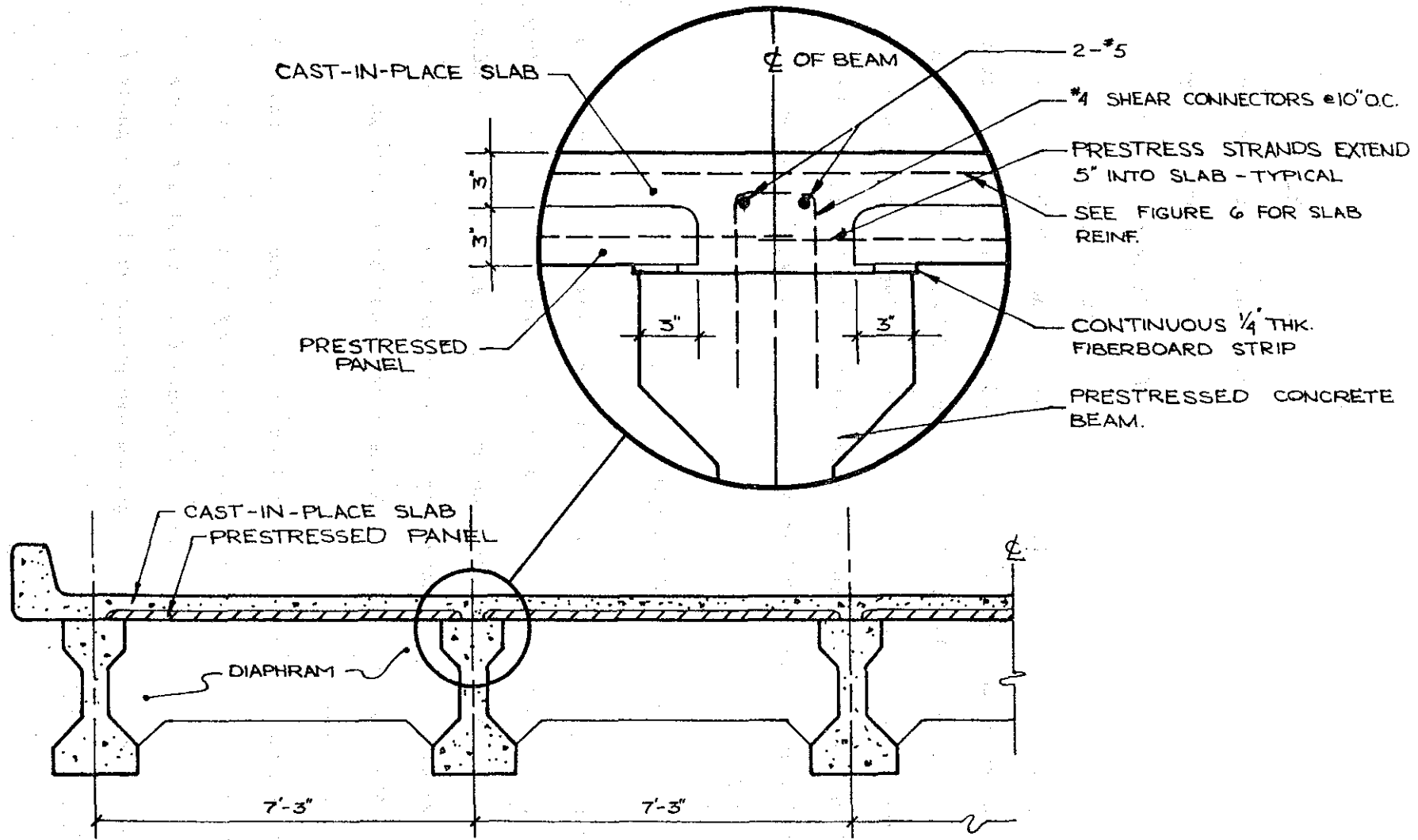

Figure 3. Arrangement of Prestressed Panel, Cast-in-place Slab and Prestressed Beam.

The prestressed panels were 6 ft.-9 in. long, 3 in. thick, and varied in width from 1 ft.-5 in. to 5 ft.-2 in. The arrangement and width of panels used in the 40 ft. and 50 ft. spans are shown in Figs. 4 and 5, respectively. All panels employed 3/8 in. diameter, 7-wire prestressing strands, spaced at 4-1/2 in. on center at mid-depth, with an initial prestress force of 14,000 lbs. per strand. Number 2 plain bars at 6 in. on center were layed on the strands to provide transverse reinforcing for the panels, while No. 5 deformed bars located as shown in Fig. 6 were used in the cast-in-place slab. A design strength of  $f'_c = 3,000$  psi was used for the concrete and  $F_y = 33,000$  psi for the conventional reinforcing. Additional prestressed panel details are contained in Fig. 7.

### III. INSPECTION OF BRIDGES

A visual inspection of the three structures was first conducted to determine their general condition. Based upon these preliminary findings, more detailed studies, which included mapping of crack patterns, soundings to detect delamination, and core samples were undertaken where deemed advisable. This portion of the work was carried out by Texas Highway Department personnel.

The Farm Road 902 overpass exhibited the least amount of wear. No significant cracks were found in the cast-in-place deck, nor in the prestressed panels. For this reason, the more detailed studies were limited to the two more heavily traveled overpasses on U. S. Highway 75.



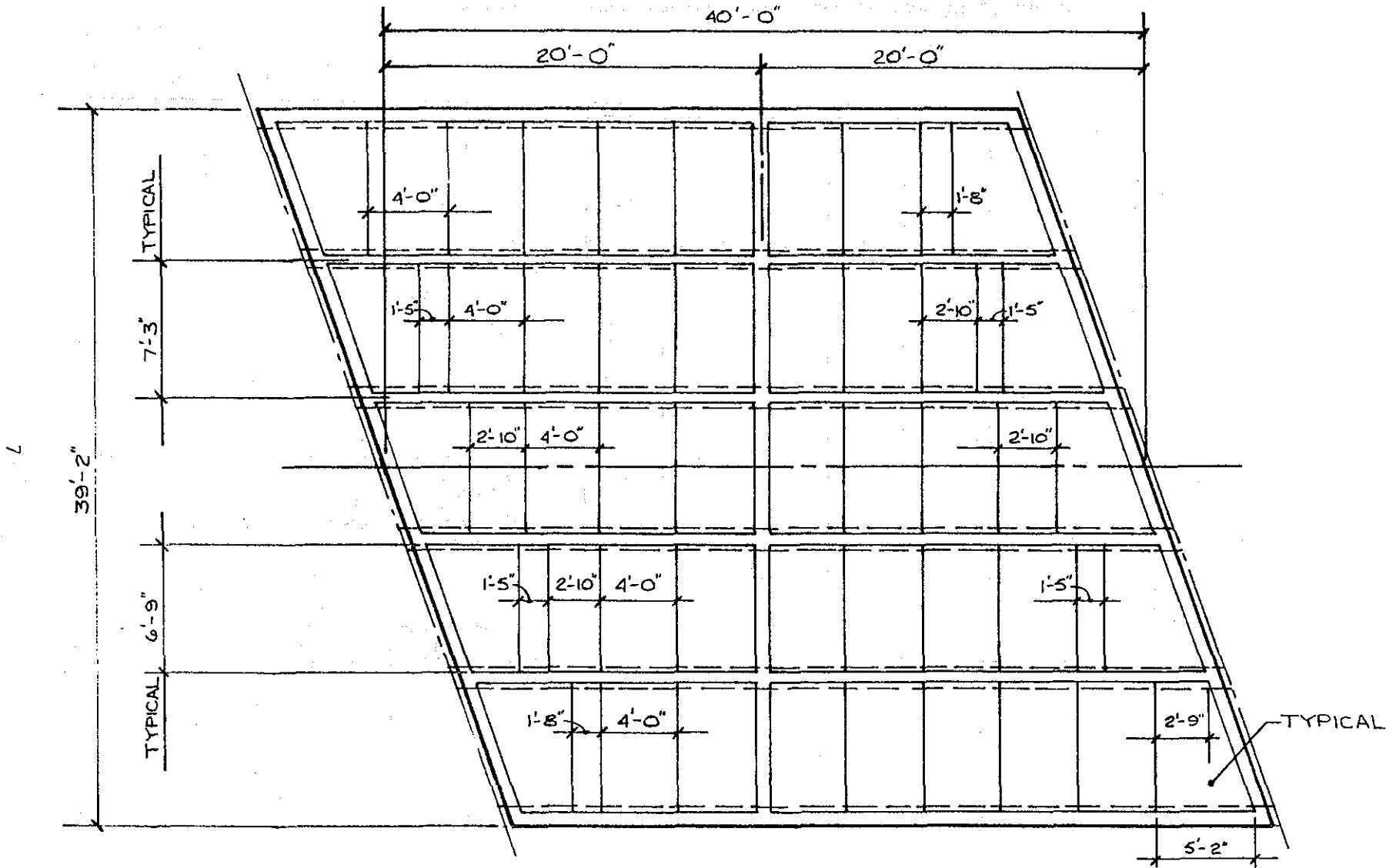

Figure 4. Prestressed Panel Layout for 40 ft Span.

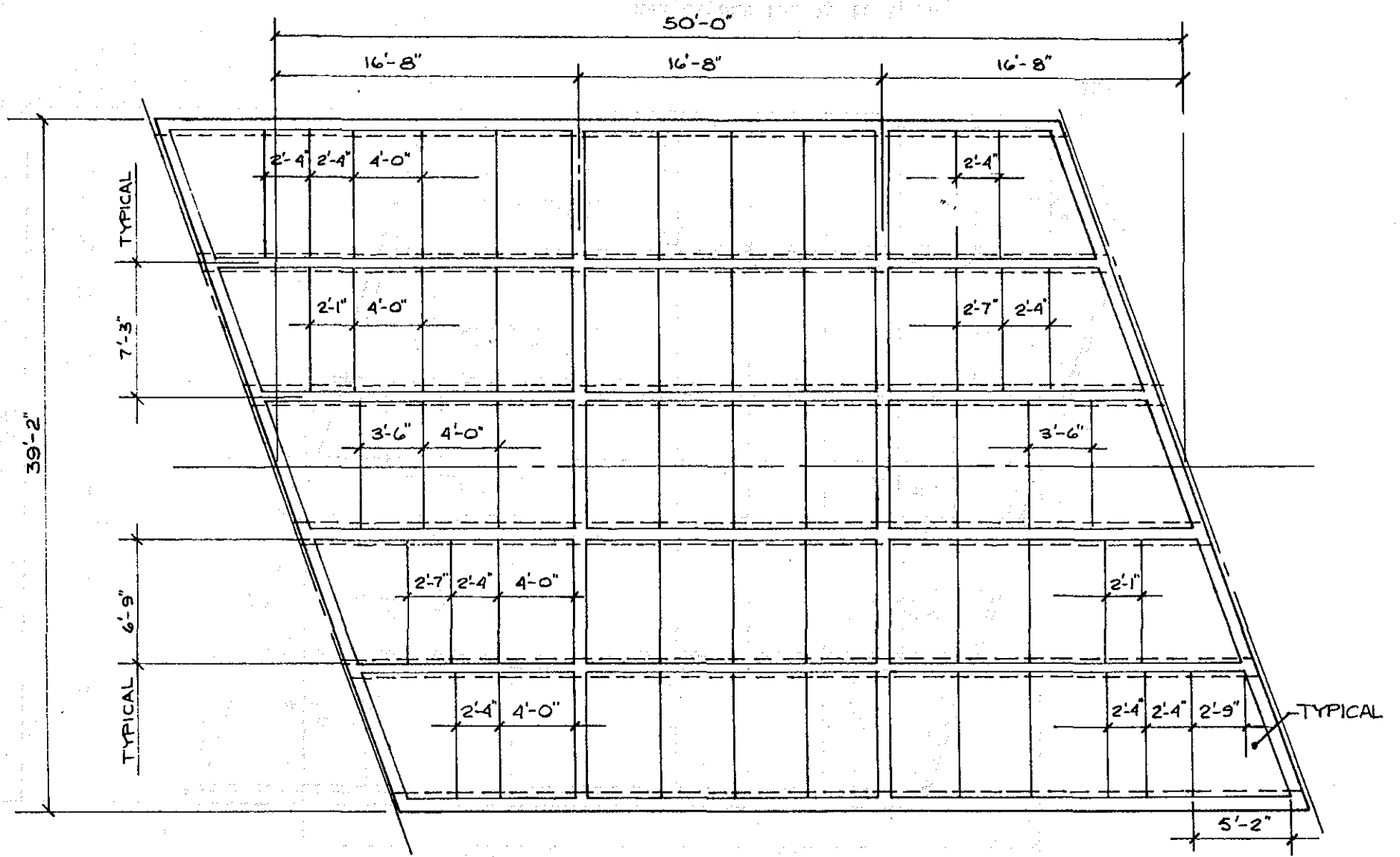

Figure 5. Prestressed Panel Layout for 50 ft Span.

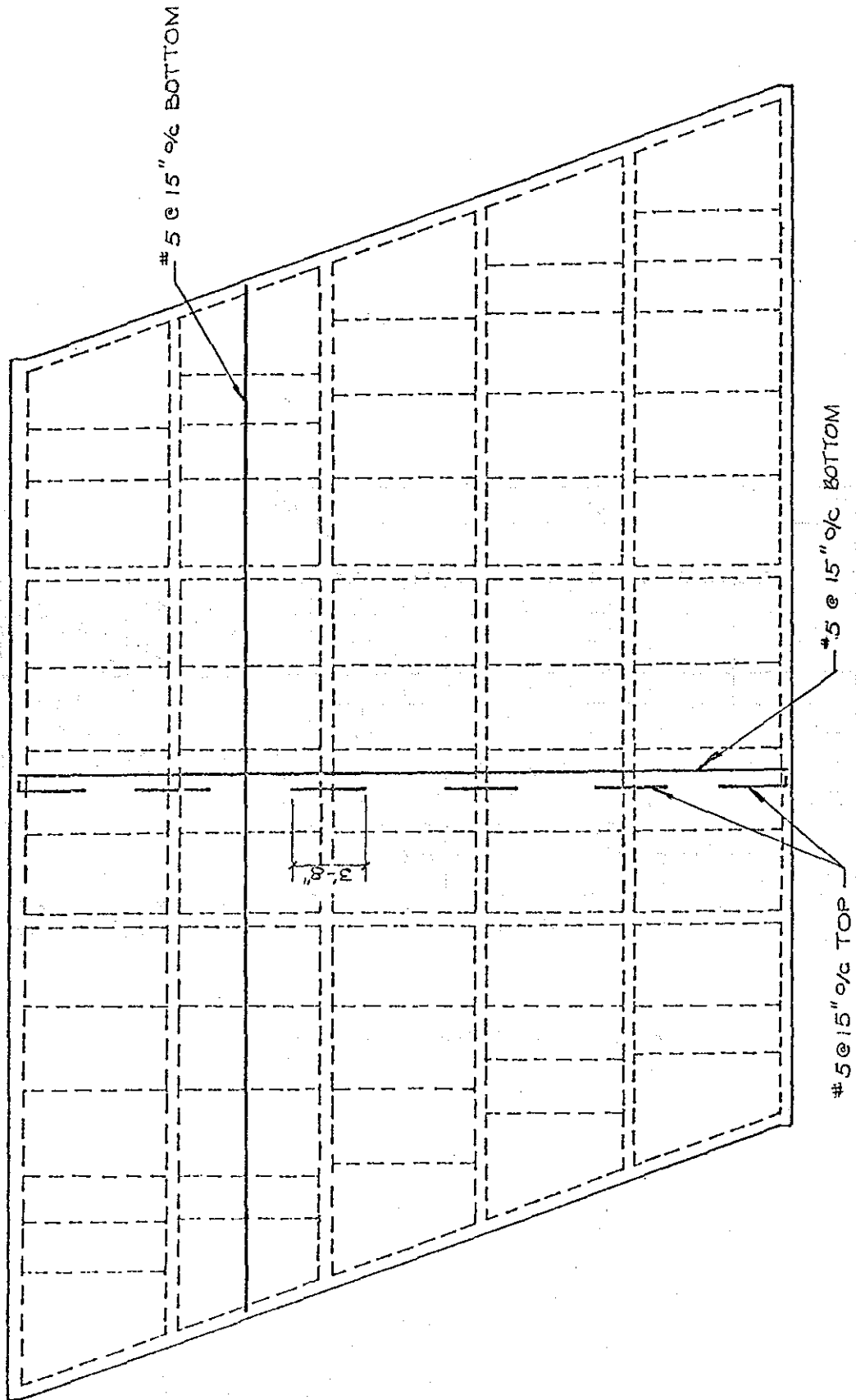

Figure 6. Reinforcing in Cast-in-place Deck.

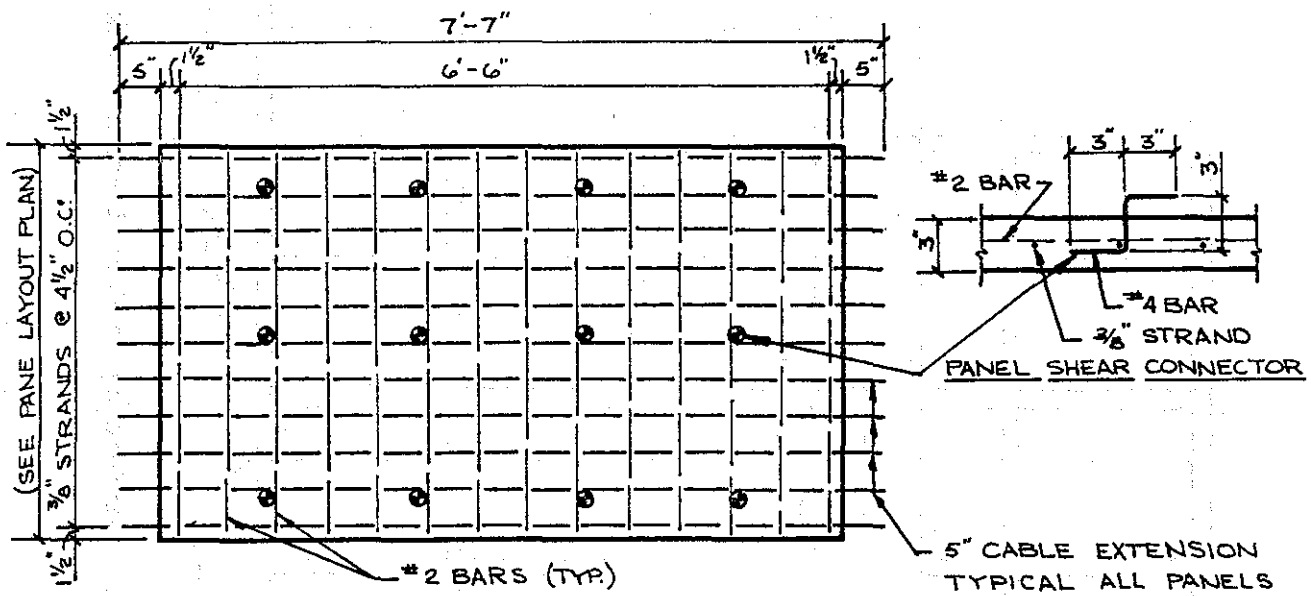

Figure 7. Typical Prestressed Panel.

1. Mapping of Crack Patterns: Some transverse cracking was visible on the cast-in-place decks of both the north-bound and south-bound overpasses. The position of those cracks which could be detected were determined by measuring their distance from one end of a span and by measuring their length. Each span of the two bridges has been assigned the identifying number shown in Fig. 2, and the crack patterns that were obtained are presented by span in Appendix A. Figure 8 shows cracks typical of those found in the decks of both structures.

2. Soundings to Detect Delamination: Serious deterioration and delamination in the interior portion of a monolithic concrete slab can usually be detected by tapping the surface of the slab. A sharp, solid sound is characteristic of sound concrete, while a hollow sound indicates the presence of delamination. For the prestressed panel and cast-in-place slab construction, a bond failure and delamination between panel and slab would be perceptible through soundings.

An electronic device<sup>(1)\*</sup> operating on the principle of differences in sound was used to inspect the right lane of the north-bound overpass. This device was rolled along the deck and gave a continuous inspection of a nine inch wide strip of slab.

The results of these soundings were almost completely negative. Only two small areas of delamination were found; the first occurred on the north approach to the bridge, a few inches from the end of span 1NB, and the second was located adjacent to the center traffic stripe in span 3NB. No delamination was found in the vicinity of any of the transverse cracks in the cast-in-place slab.

---

\*Superscripts refer to entries in the list of references.

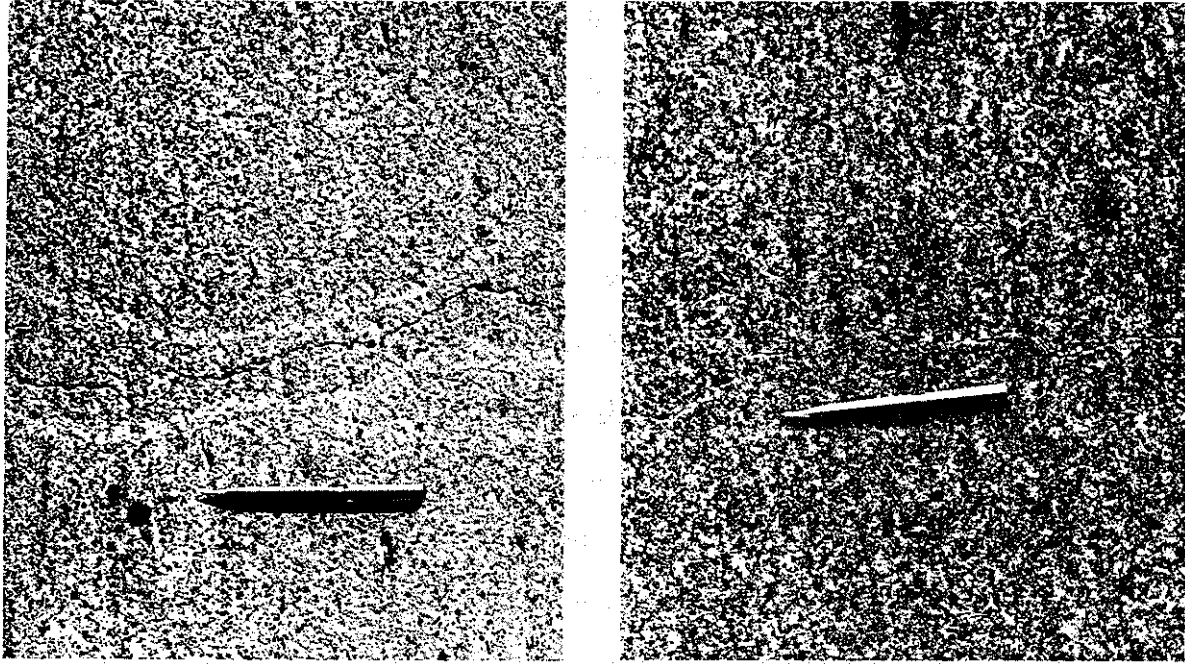

Figure 8. Typical Transverse Cracks in Cast-in-place Deck.

3. Core Samples: The north end span of the north-bound overpass was chosen for coring, and four, 4 in. diameter cores were taken at the locations indicated in Fig. A.1.

Core No. 1 was taken in an uncracked region at the center of a prestressed panel. The core dropped through the deck, fell approximately 5 ft. onto the sloping concrete abutment below and rolled to the bottom. The sample, which remained intact after the fall, is shown in Fig. 9. The visible face of the core is the top of the cast-in-place deck.

The second and third cores were taken over a joint between two prestressed panels, at a point where a crack occurred in the cast-in-place slab. The second core, like the first, fell through the deck. It broke into several pieces, which were reassembled for the photograph shown in Fig. 10. The sample split vertically through the crack in the cast-in-place slab and horizontally along part of the interface of the slab and prestressed panel. The bond between these two elements to the left of the vertical split remained secure.

The third sample, shown in Fig. 11, lodged in the coring bit and was broken at the interface of the precast and cast-in-place concrete when attempts were made to pry it from the coring tool. The concrete over the face of separation was clean, which indicated a new break, not an old one.

The fourth core was taken from an area slightly offset from a crack, and was drilled only through the cast-in-place portion of the deck. It was broken from the precast panel by a wedge driven into the cut. The break was clean at the interface of precast and cast-in-place

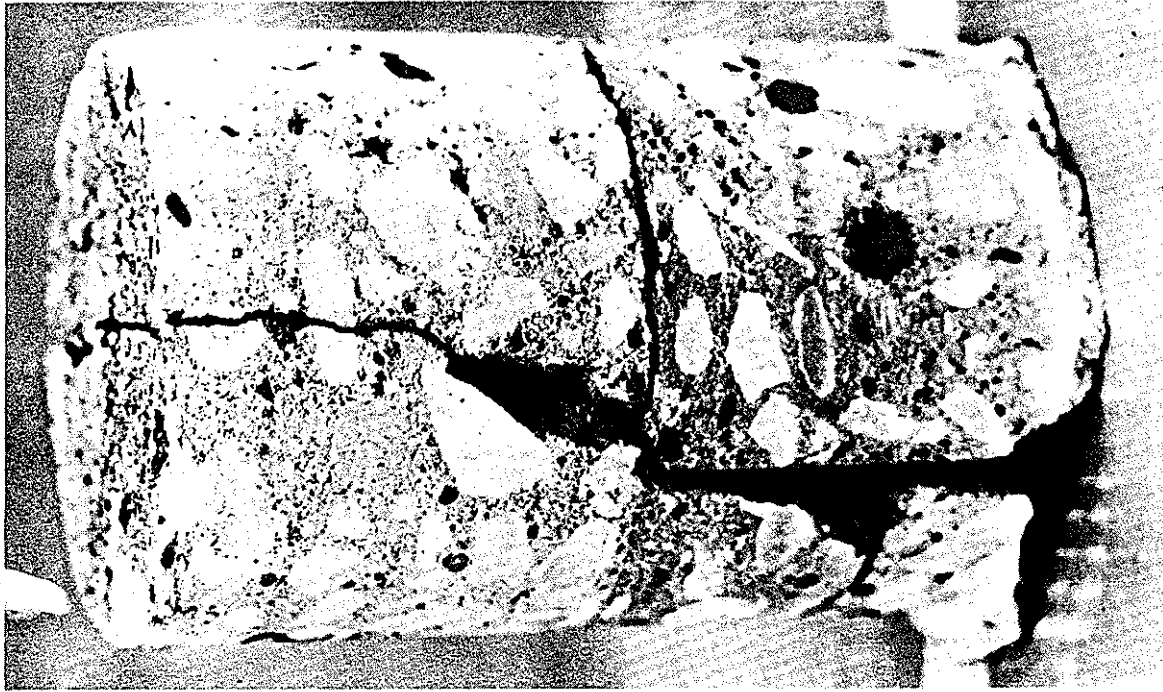

Figure 10. Core Sample No. 2.

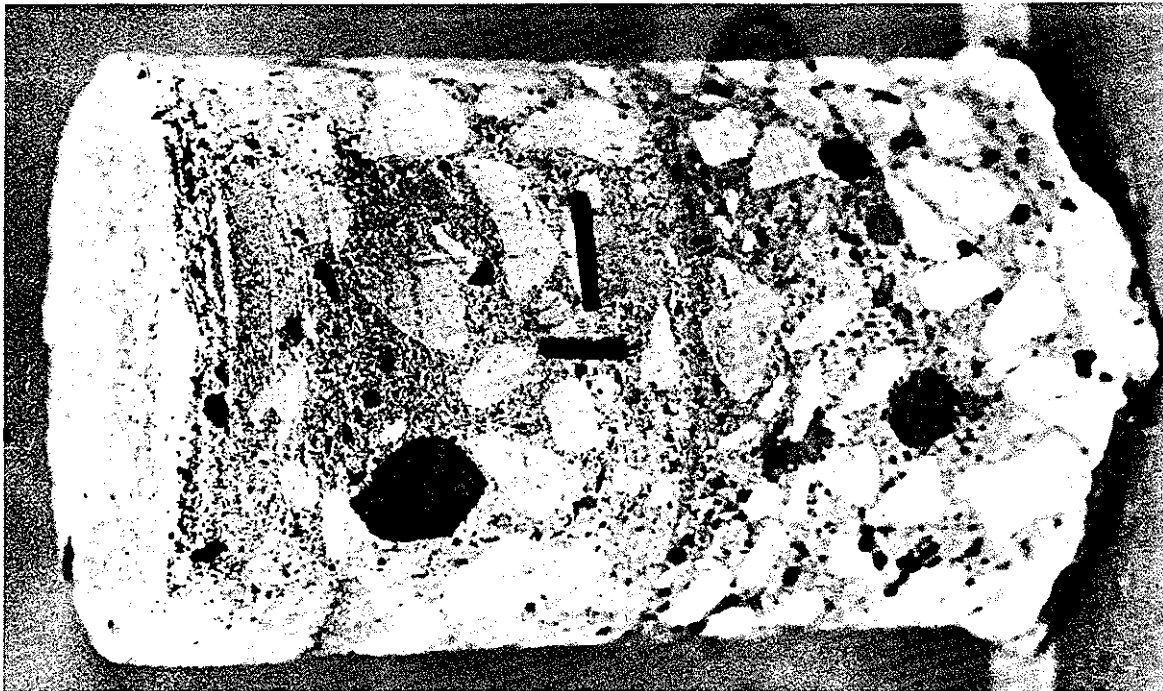

Figure 9. Core Sample No. 1.





Figure 12. Core Sample No. 4.



Figure 11. Core Sample No. 3.

concrete, and the drill operator estimated that it took about as much force to break it as was his experience to use in breaking out a core from a monolithic pour. An inspection of the exposed upper face of the prestressed panel gave no indication of an unbonding or delamination between slab and panel. The core sample is shown in Fig. 12.

The position of the second and third cores over a crack in the cast-in-place slab permitted an estimate of the depth of such cracks by observing the extent of the discoloration of the concrete. Figure 13 shows core sample No. 2, layed open along the vertical crack shown in Fig. 10. The top surface of the deck, visible in Fig. 10, is at the top of Fig. 13. It appears that the crack in the cast-in-place slab extended approximately half way through the slab, based on the depth of darkened concrete visible.

Core sample No. 1 was subjected to a direct shear test<sup>(2)</sup> to determine an average bond stress between prestressed panel and cast-in-place slab. Two forces, parallel to the interface between slab and panel (see Fig. 14) were applied until separation of these two elements occurred. A force of 3600 lbs. was required, which divided by the cross sectional area of the core gave an average bond stress of 285 psi.

#### IV. LOAD TESTS

A load test was performed on span 2NB of the U. S. Highway 75 overpass to further determine the extent of composite action between beams, panels, and cast-in-place slab. This span was chosen because it was more easily accessible for the installation of instrumentation and



Figure 13. Discoloration of Concrete at Crack in Cast-in-place Deck.

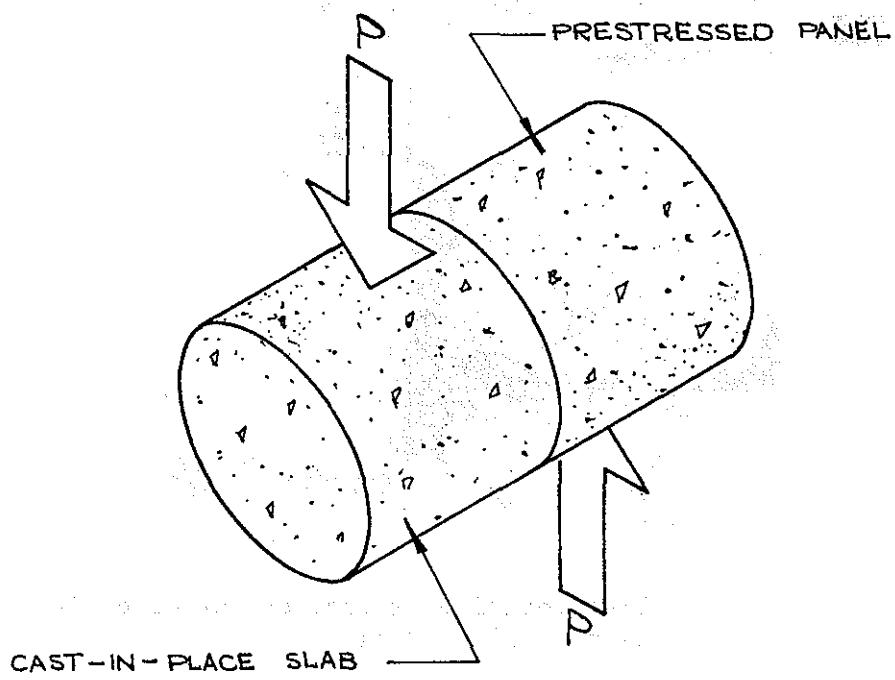

Figure 14. Shear Test of Core Sample.

the frequency of cracks in the cast-in-place deck was typical of the other 50 ft.-0 in. spans. The instrumentation consisted of electrical resistance strain gages and two dial gages. The strain gages were arranged in two similar patterns, as shown in Fig. 15. The locations of the gages within each pattern are shown in Figs. 16 and 17. Wherever possible, pairs of gages were used; one on the top of the cast-in-place deck and another directly below it on the underside of the prestressed panel.

The position of each gage was determined by measurements from the edge of the curb and from the expansion joint at the end of the span. The concrete surface beneath the gage was cleaned with acetone and a stiff bristle brush. A layer of polyester resin, just thick enough to provide a smooth surface for the gages, was then brushed onto the cleaned area and allowed to harden. The strain gages were attached to the resin surface using Eastman 910 contact cement, and a waterproofing compound was placed over the gages. Figure 18 and 19 show typical strain gage installations.

In addition to the gages used in patterns No. 1 and 2, strain gages were mounted on the walls of core hole No. 1, to measure strains through the depth of the slab, and dial gages were positioned on the underside of the bridge to detect differential movement between elements of the structure. Six strain gages were placed in the core hole at the locations shown in Fig. 20, to measure strains in both the longitudinal and transverse directions. The dial gages used were sensitive to 1/1000 in. and were placed near midspan of 2NB. The gage shown in Fig. 21 measured

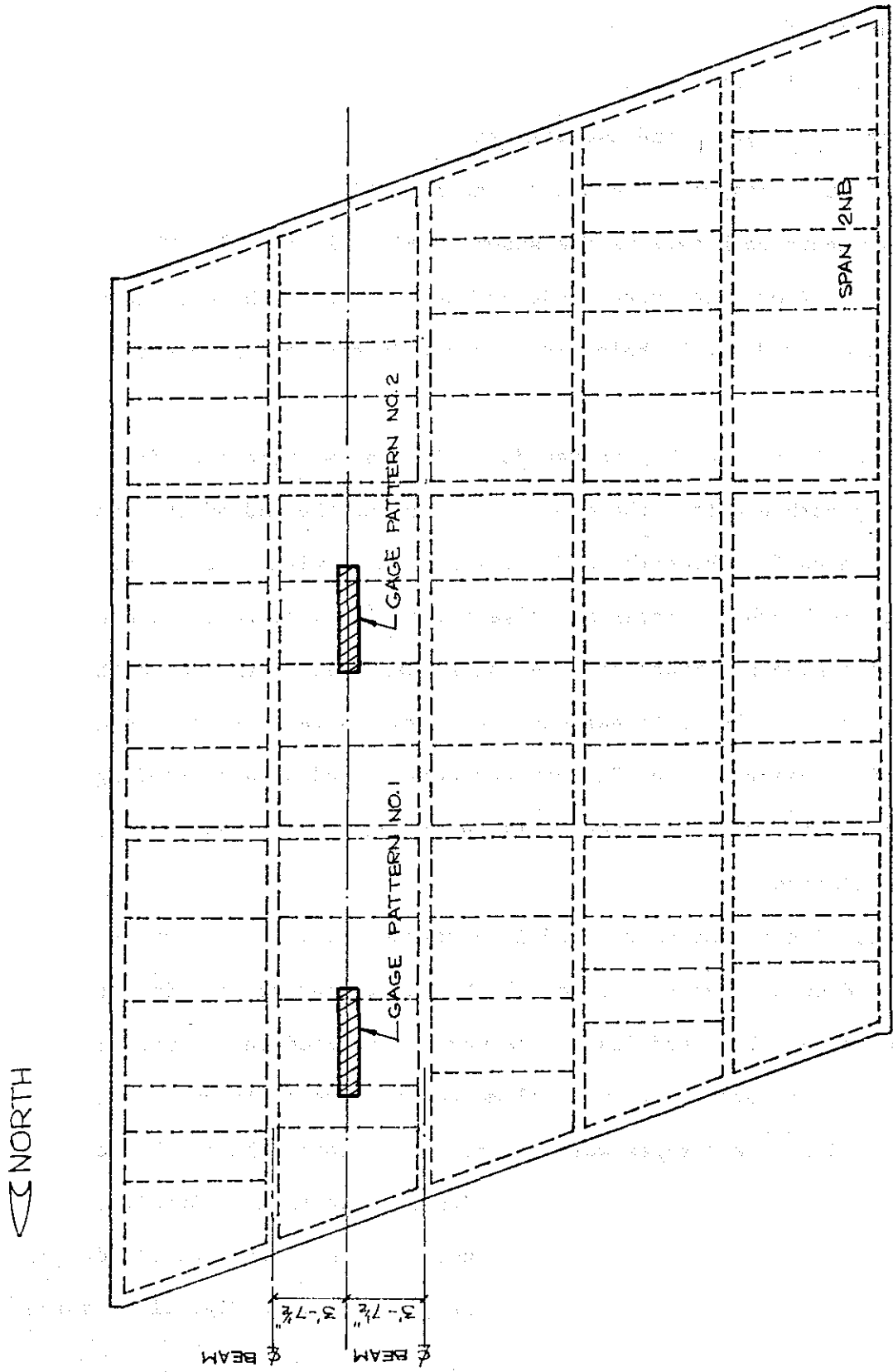

Figure 15. Location of Strain Gage Patterns on Span 2NB.

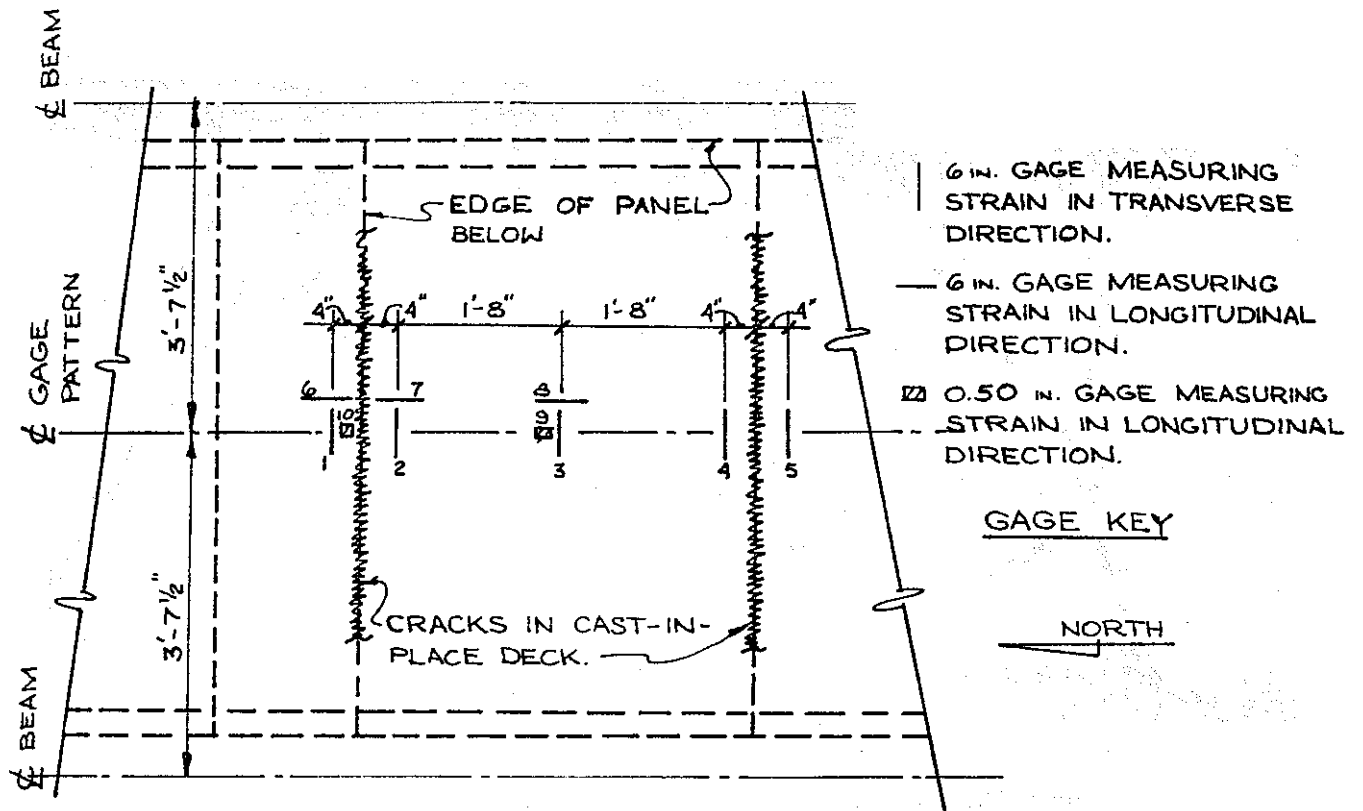

Figure 16. Location of Strain Gages in Pattern No. 1.

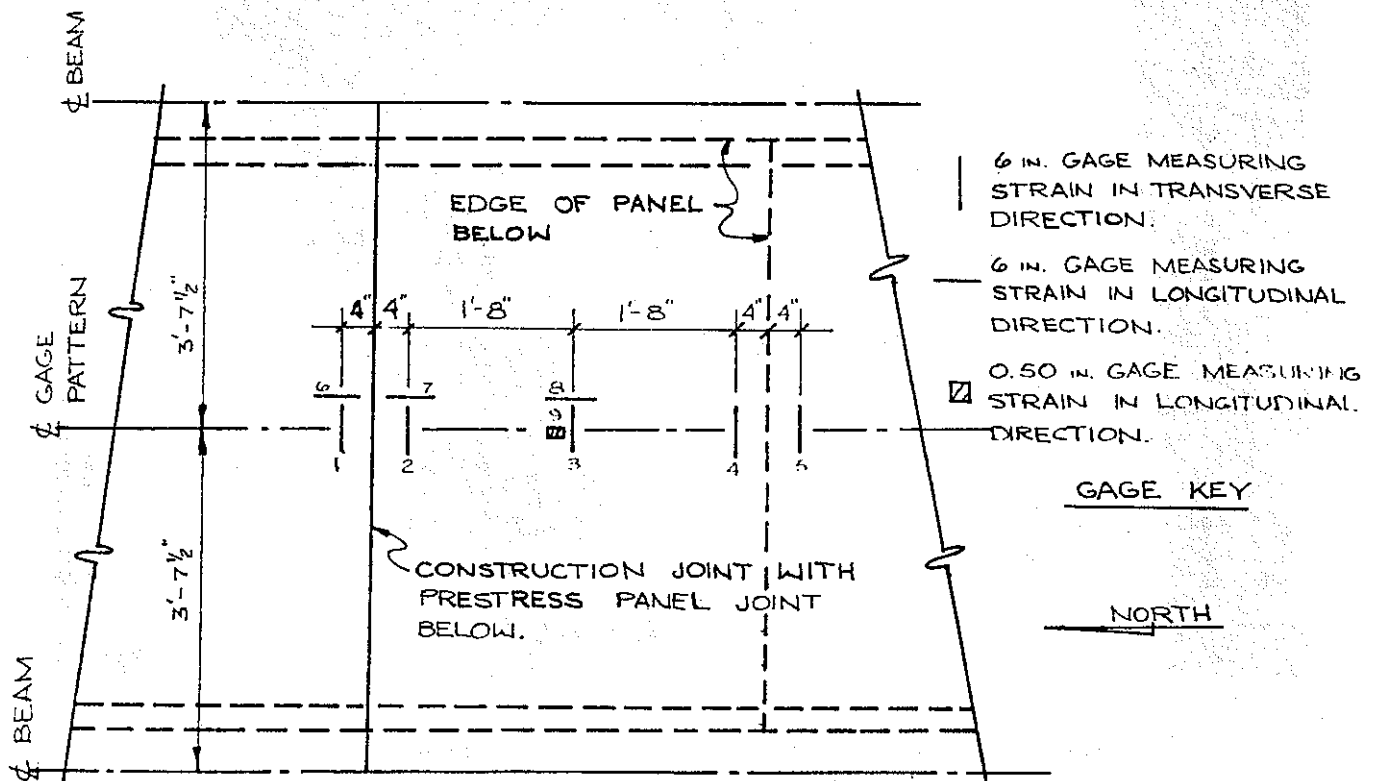

Figure 17. Location of Strain Gages in Pattern No. 2.

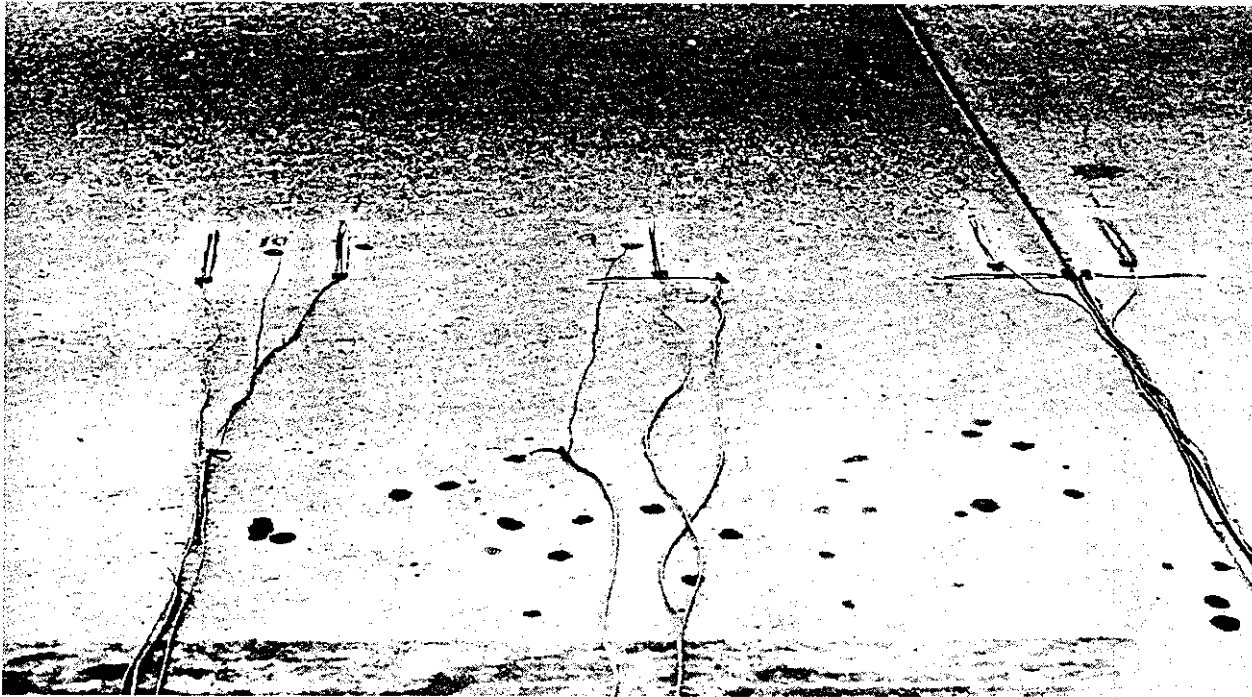

Figure 18. Typical Strain Gage Installation on Top of Cast-in-place Deck.

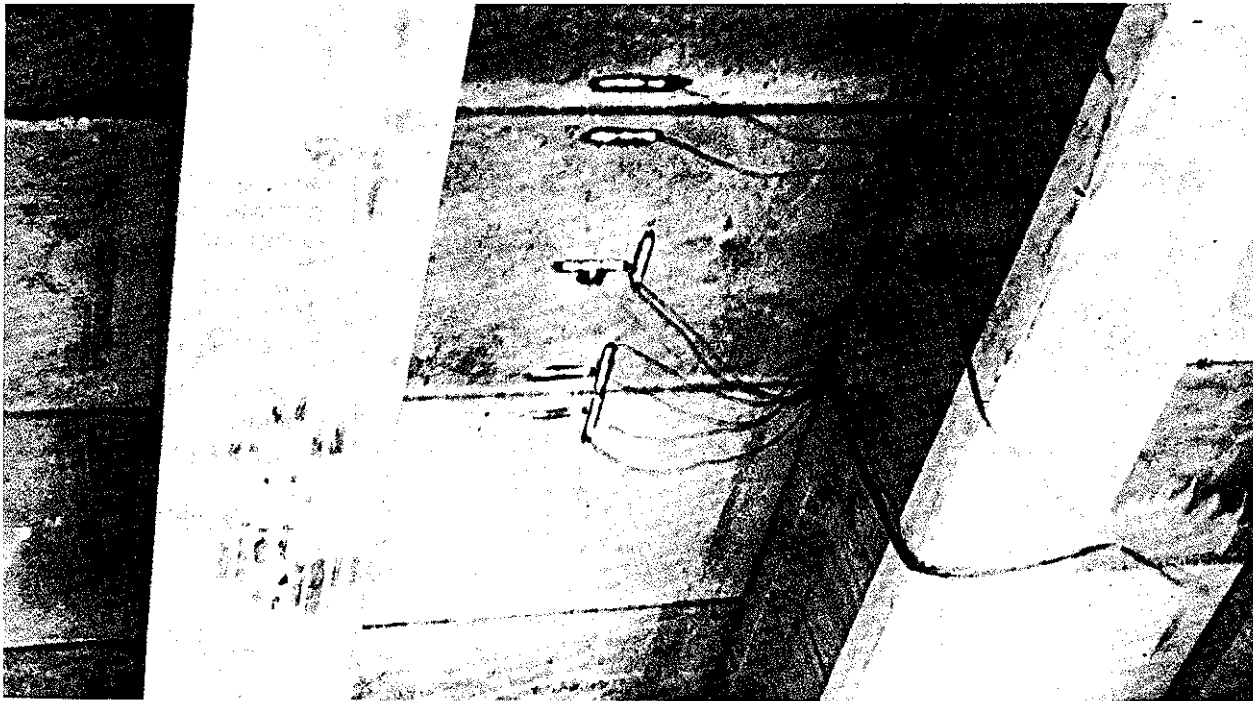

Figure 19. Typical Strain Gage Installation on Underside of Prestressed Panels.



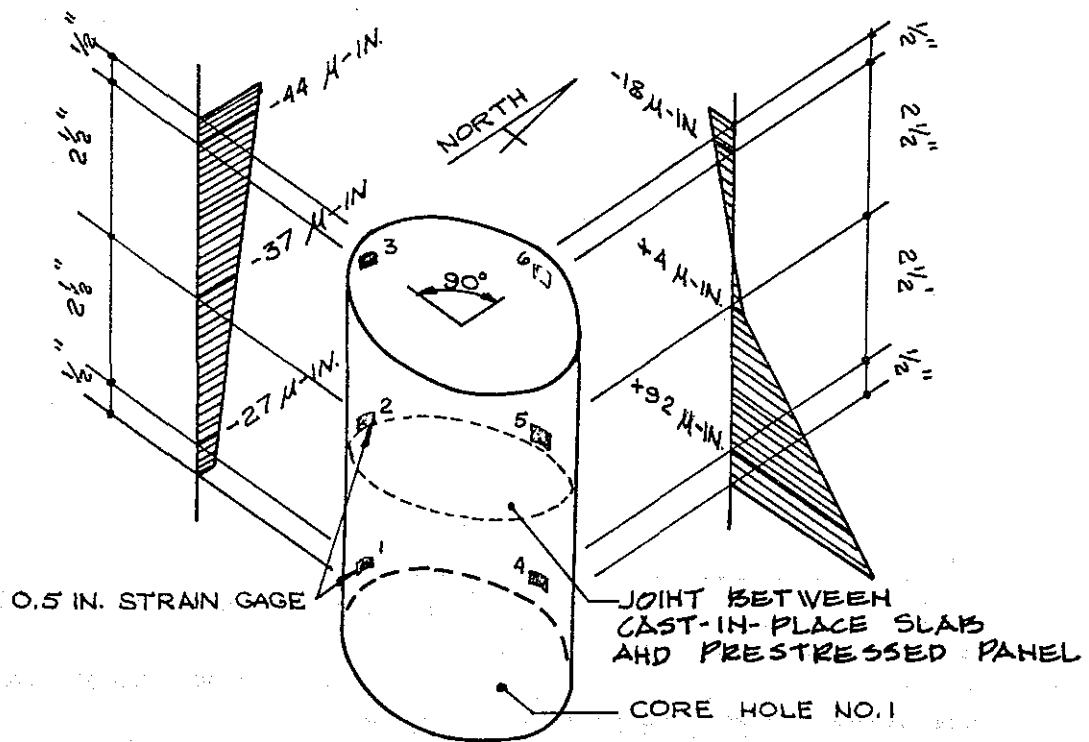

Figure 20. Location of Strain Gages and Strain Readings in Core Hole No. 1.

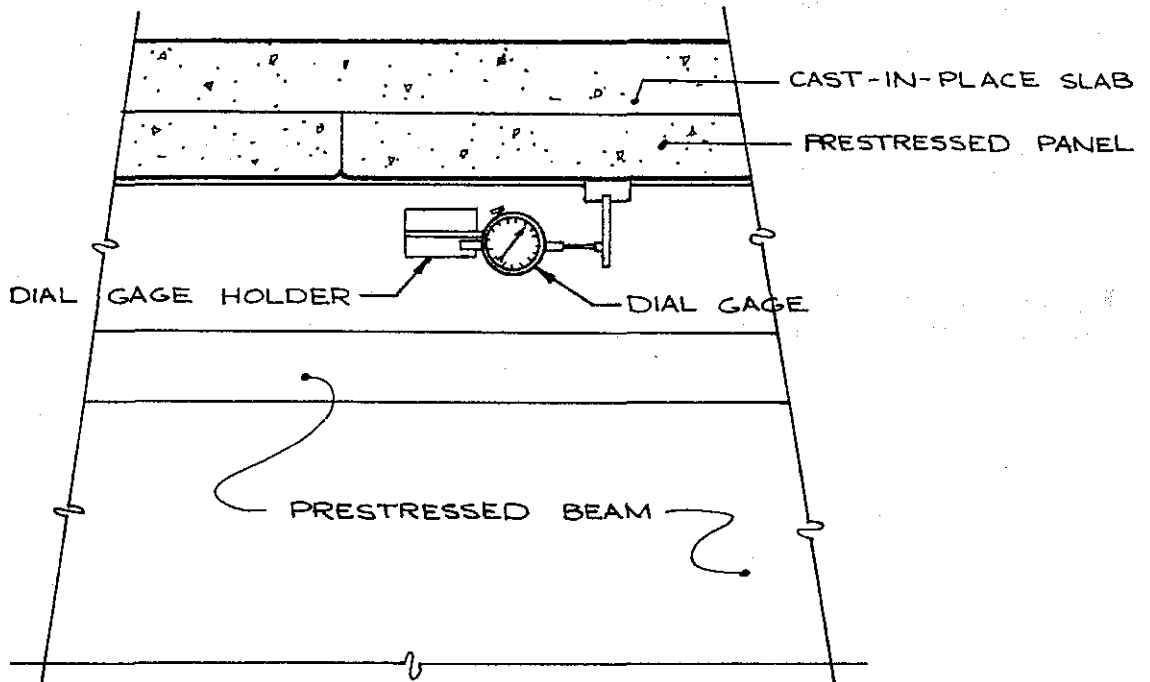

Figure 21. Dial Gage Installation to Detect Slippage Between Prestressed Beam and Panel.

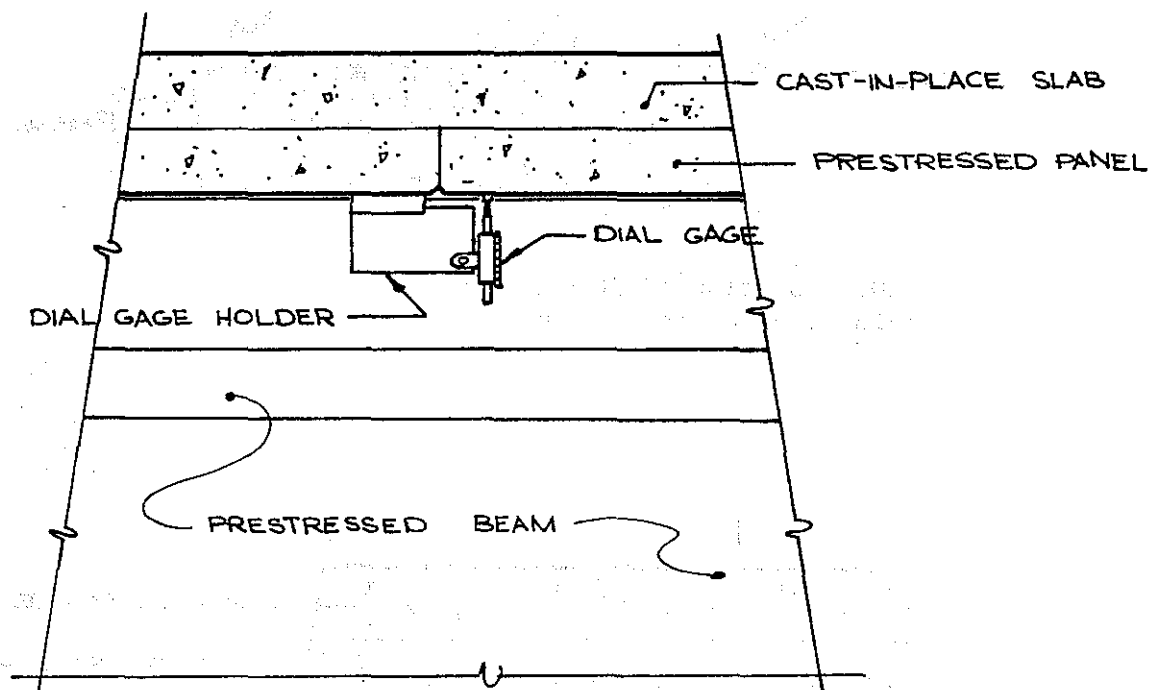

Figure 22. Dial Gage Installation to Detect Relative Displacement Between Two Adjacent Prestressed Panels.

slip between prestressed panel and beam, and that shown in Fig. 22 was used to measure relative vertical movement between two adjacent prestressed panels.

A set of static readings were taken from the strain gages in patterns No. 1 and 2, core hole No. 1, and from the dial gages mounted under span 2NB. The loaded dump truck shown in Fig. 23 was used as the test vehicle. The truck had a total weight of 71,800 lbs., and the wheel loads and axle spacings indicated in Fig. 24. The wheel loads were determined by weighing each wheel independently. Strain readings were taken from each gage pattern with the two rear wheels adjacent to the gages, as shown in Fig. 25. For readings from the gages in the core hole, the truck was positioned to the west of the hole, and with its rear-most axle even with it. The distance between the outside line of wheels and the edge of the hole was approximately 12 in. The two dial gages were monitored while the truck was aligned with gage pattern No. 2.

Dynamic strain readings were taken from the gages in patterns No. 1 and 2 with the test vehicle moving at approximately 20 mph., along the path indicated in Fig. 25. All strain traces were recorded by a Honeywell Visicorder oscillograph and amplifier system, capable of recording the output from 12 gages simultaneously. Thus, four passes with the test vehicle were needed to record the strains from all gages. On a single pass, all top or all bottom gages in one of the patterns were read. The left lane of the north-bound overpass remained open to traffic during the load test and on several occasions cars passed over

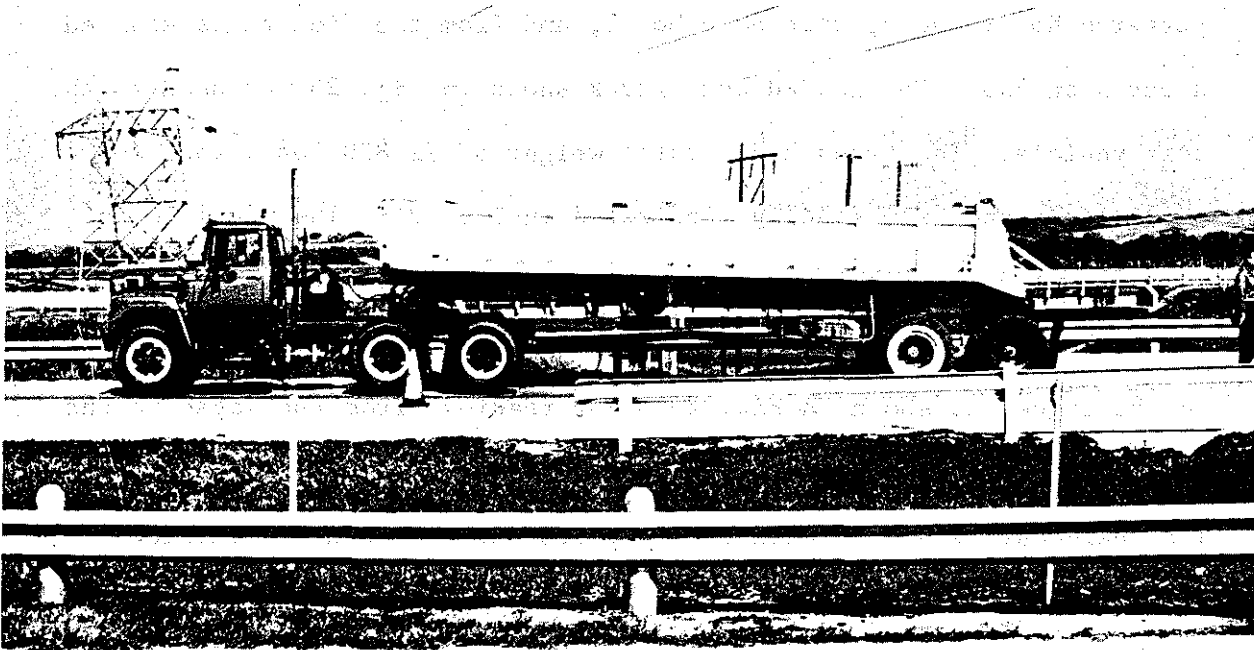

Figure 23. Test Vehicle.

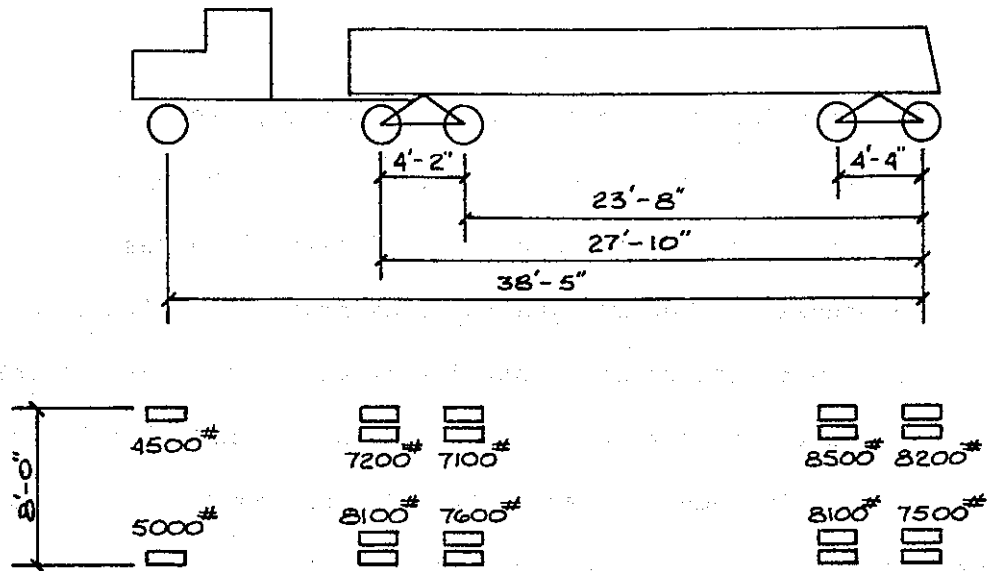

Figure 24. Dimensions and Wheel Loads of Test Vehicle.

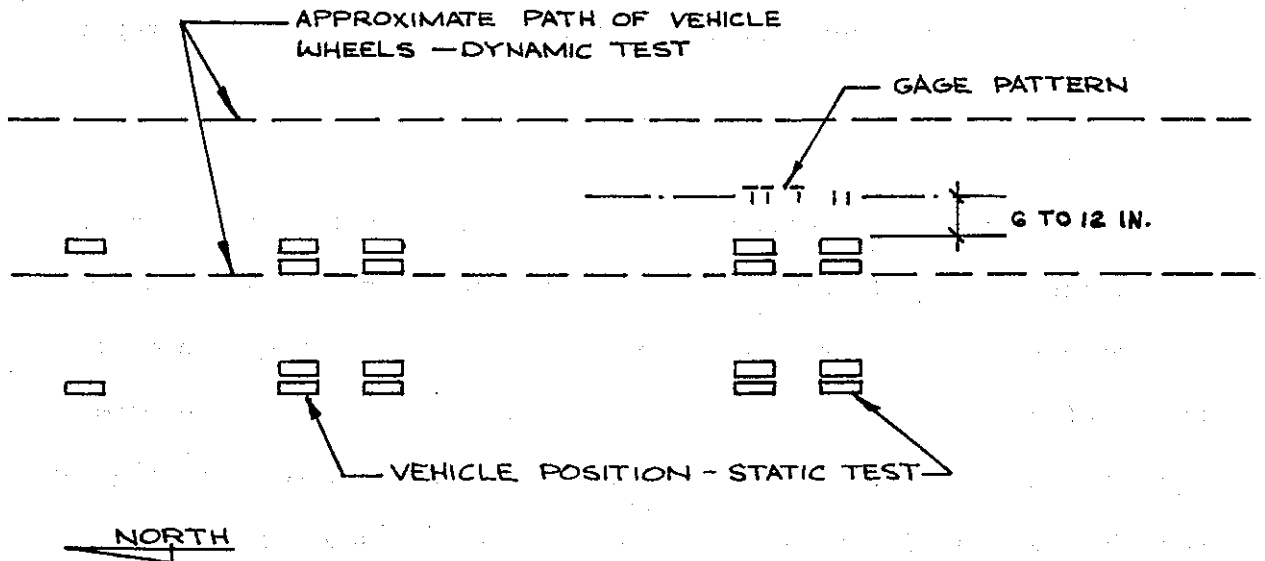

Figure 25. Position of Test Vehicle for Static and Dynamic Load Tests.

the bridge while readings were being taken. However, precautions were taken to see that no trucks crossed the bridge during these times.

The strain readings from the static and dynamic load tests are presented in Appendix B. The strains recorded from each pair of top and bottom gages in a pattern are plotted against the estimated truck position, relative to these gages. Three reference lines, labeled A, B, and C, have been included on each plot and correspond to the relative truck positions shown in Fig. 26. The horizontal dashed lines on each graph are the strains recorded during the static test.

One set of static readings was taken from the gages mounted in core hole No. 1. The test vehicle was positioned as shown in Fig. 26, truck position C. The resulting strains are shown in Fig. 20. No dynamic strain readings were taken from these gages.

There were no differential movements between prestressed panel and beam, or between adjacent panels recorded by either of the dial gages.

## V. DISCUSSION

With only a few exceptions, the cracks found in the cast-in-place deck coincided with transverse butt joints between prestressed panels. They occurred between prestressed beams, usually along the path of the wheels of a vehicle in the right traffic lane. The cracks were more numerous in the shorter, end spans, and in all spans were more frequent towards the ends of the span. Based upon the core samples taken, the cracks appeared to extend approximately halfway through the cast-in-place slab.

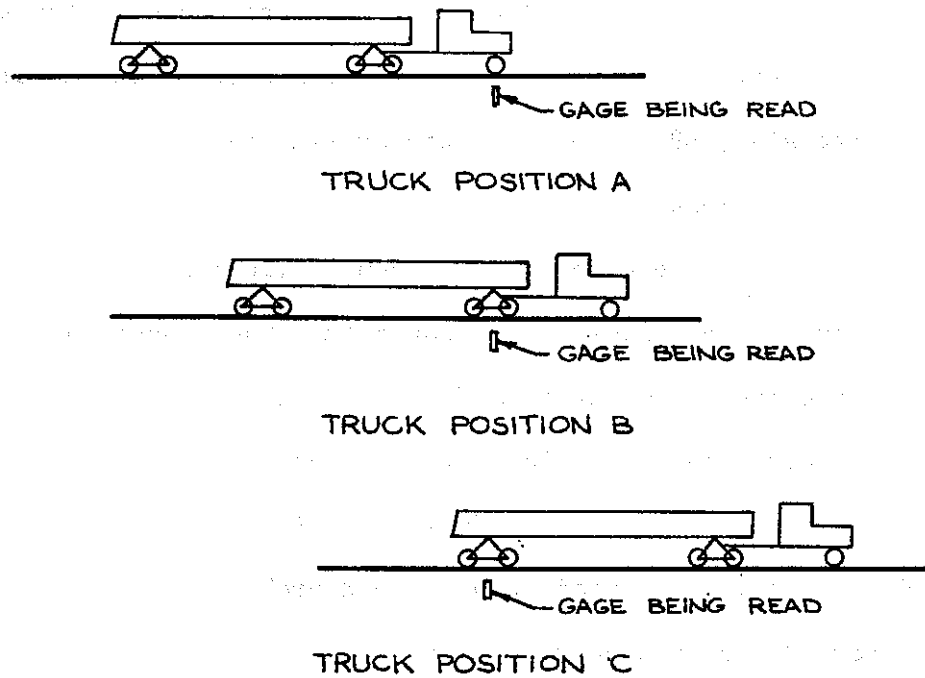

**Figure 26. Reference Positions of Test Vehicle Relative to Strain Gage Being Recorded.**

The prestressed subdeck panels had the effect of controlling the spacing of transverse cracks since these cracks occur almost exclusively over the joints between adjacent panels. The predominant panel width in the bridges under investigation was 4 ft.-0 in. It is of interest to compare this frequency of transverse cracking with that occurring in decks of comparable bridges constructed with monolithic slabs. A recent survey<sup>(3)</sup> of the general condition of all bridge decks in the state of Texas reports that for bridges with prestressed beams and monolithic cast-in-place slab, 69 percent had transverse cracks at average intervals of 4 ft.-0 in. or less.

There was no evidence of service bond failure at the interface of precast concrete and cast-in-place concrete. The breaks that occurred in the cores were due to impact from falling or from a hammer and wedge.

In each core, the finishing marks in the concrete at the interface between slab and panel were well defined. If slippage along this interface had occurred, these projections would probably have been ground smooth. Some discoloration was noted on the interface of core No. 3, possibly from oil or curing compound present on the top face of prestressed panel prior to pouring of the cast-in-place slab. This may have contributed to the partial separation of the core along this interface. The one core sample which was removed intact and subjected to a direct shear test exhibited substantial bond strength.

The strains recorded by the gages in patterns No. 1 and No. 2, and presented in Appendix B of this report, were taken to test the continuity of action between prestressed panels and cast-in-place slab. Only qualitative results were sought from these tests because of the



inherent inaccuracies involved in measuring small strains in concrete structures in the field under rapidly fluctuating temperature conditions. The rapid temperature fluctuations in this test resulted from intermittent clouds briefly shading the bridge surface from the sun, and from gusts of wind blowing over the deck. It was anticipated that a lack of continuity between prestressed panel and slab would be reflected by a sudden jump or discontinuity in the strain trace from one or more gages. A similar result was expected from those gages measuring transverse strains on either side of a panel joint if the transfer of wheel loads between adjacent panels was uneven. No such jumps or discontinuities were found in the strain traces recorded.

In general, those gages mounted on the top of the cast-in-place slab exhibited a greater sensitivity to changing wheel position, as evidenced by the five distinct peaks in the strain traces corresponding to the passage of each of the five axles of the test vehicle. The strain readings from those gages attached to the bottom of the prestressed panels tended to peak only at the two instances where the pairs of vehicle trailer axles passed by the gages. With the exception of gage 10 in pattern No. 1, only compressive strains were recorded by gages mounted on the top of the cast-in-place slab.

Among those gages reading strains in the transverse direction (gages 1 through 5 in both patterns), several trends were observed. The strain traces from gages located on either side of a panel joint (gages 1 and 2, and 4 and 5 in both patterns) show a smooth transfer of wheel loads from panel to panel. These gages recorded strains before

a vehicle wheel came in contact with the panel to which they were attached, and after all wheels had passed beyond the panel. The traces had similar shapes, as seen from comparing Figs. B.1 and B.2, B.4 and B.4, B.11 and B.12, and B.14 and B.15.

Gages 6 through 10 in patterns No. 1 and No. 2 measured longitudinal strains. With the exception of the top gage number 10 in pattern No. 1, all top gages recorded only compressive strains throughout the test. The longitudinal gages on the bottom of the panels, however, fluctuated between tension and compression, with approximately equal maximum values of each. The strain traces from the 6 in. gages (numbers 6, 7, and 8) appear to be more uniform than those from the 0.5 in. gages (numbers 9 and 10).

The six gages mounted in core hole No. 1 provided strain profiles through the slab and panel, in both the transverse and longitudinal directions. As expected, the strains in the longitudinal direction were all compressive, with the largest value occurring at the top of the cast-in-place slab and decreasing almost linearly with depth. The strains in the transverse direction varied from compressive in the top of the slab to tension at the bottom of the panel, with approximately zero at mid-depth.

A rough calculation was run to determine the expected static strains for transverse gages 1 through 5 in gage pattern 2. The calculations assumed that complete continuity of action between prestressed panel and cast-in-place slab was present so the two elements behaved as a monolithic slab of equal thickness. A transverse strip

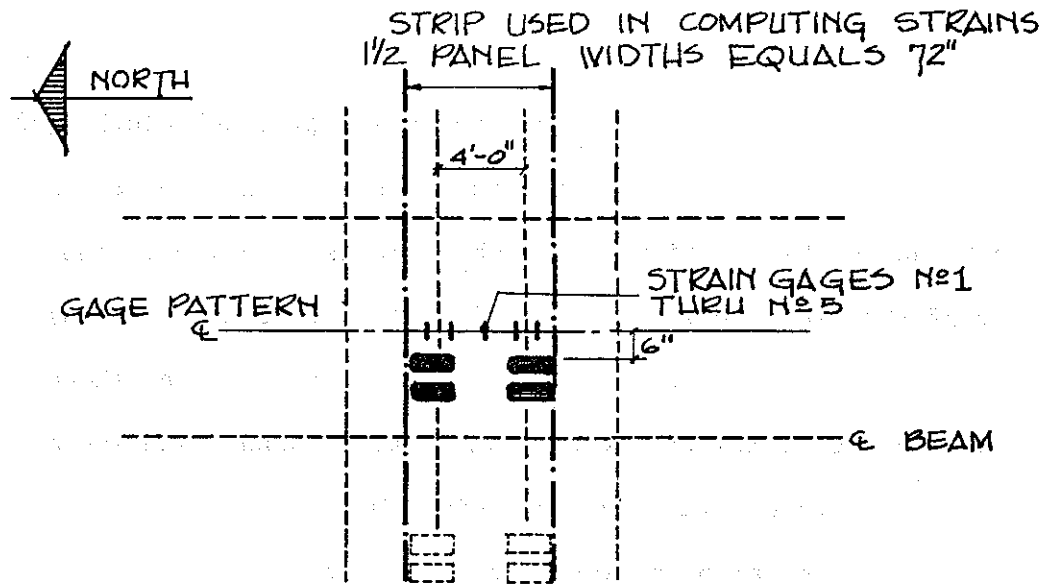

Figure 27. Arrangement of Load and Assumed Transverse Strip for Strain Calculations.

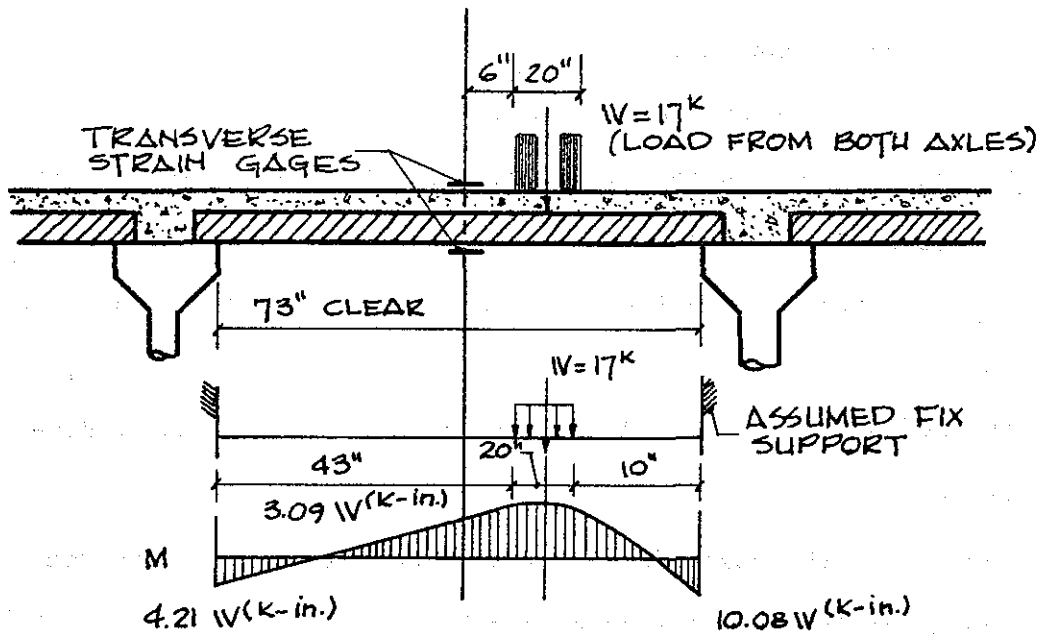

Figure 28. Transverse Support and Loading Assumptions for Strain Calculations.

of slab whose width was equal to one and one-half panel widths (72 in.) was assumed to carry the loads from the wheels of the two rear axles. Figure 27 shows the position of the wheel loads relative to the strip. The sum of the two axle loads (approximately 17,000 lbs.) was assumed to be distributed transversely over a 20 in. wide strip as shown in Fig. 28. The resulting transverse moment at midspan, assuming each end of the slab to be fixed, was 52 k-in. Using a slab strip width of 72 in., a thickness of 6 in. and a modulus of elasticity of 5 millions psi. for the concrete gives a computed midspan transverse strain of 24 micro-inches. This compares favorably with the value of 21 micro-inches obtained from averaging the top and bottom static strain readings from gages 1 through 5 in pattern No. 2.

## VI. CONCLUSIONS

Based upon the results of the inspection and load tests performed, the following conclusions have been drawn regarding the condition and performance of the three bridges studied:

1. No cracking or distress is present in the prestressed panels.
2. A secure bond between prestressed panel and cast-in-place slab is present, causing these two elements to act as a unit.
3. The bridges are in sound condition and show no signs of distress.
4. In view of the observed effect of panel width on transverse crack spacing, greater panel widths would be desirable.

#### REFERENCES

1. Moore, William, Swift, Gilbert, and Milberger, Lionel, "An Instrument for Detecting Delamination in Concrete Bridge Decks," Research Report 130-4, Texas Transportation Institute, Texas A&M University, College Station, Texas, August 1970.
2. Furr, Howard, Ingram, Leonard, and Winegar, Gary, "Freeze-Thaw and Skid Resistance Performance of Surface Coatings on Concrete," Research Report 130-3, Texas Transportation Institute, Texas A&M University, College Station, Texas, October 1969.
3. Darroch, J. G., and Furr, H. L., "Bridge Deck Condition Study - Part 2 - Relative Frequency Tables Displaying Associations Between Structural Characters and Deck Conditions," Research Report 106-1F, Part 2, Texas Transportation Institute, Texas A&M University, College Station, Texas, Submitted for approval April 1970.



APPENDIX A  
CRACK PATTERNS

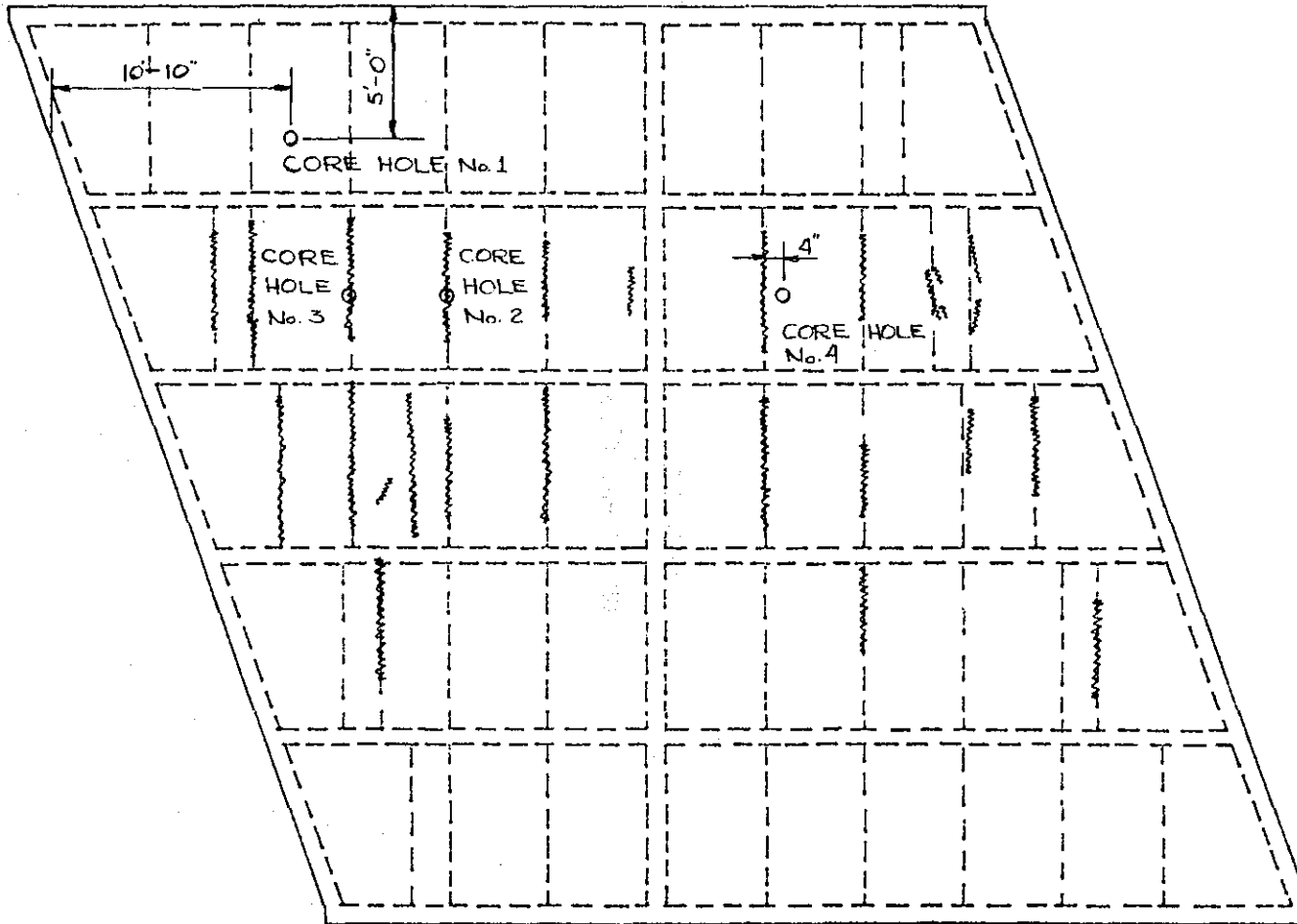

Figure A.1. Cracks in Cast-in-place Deck, Span 1NB.



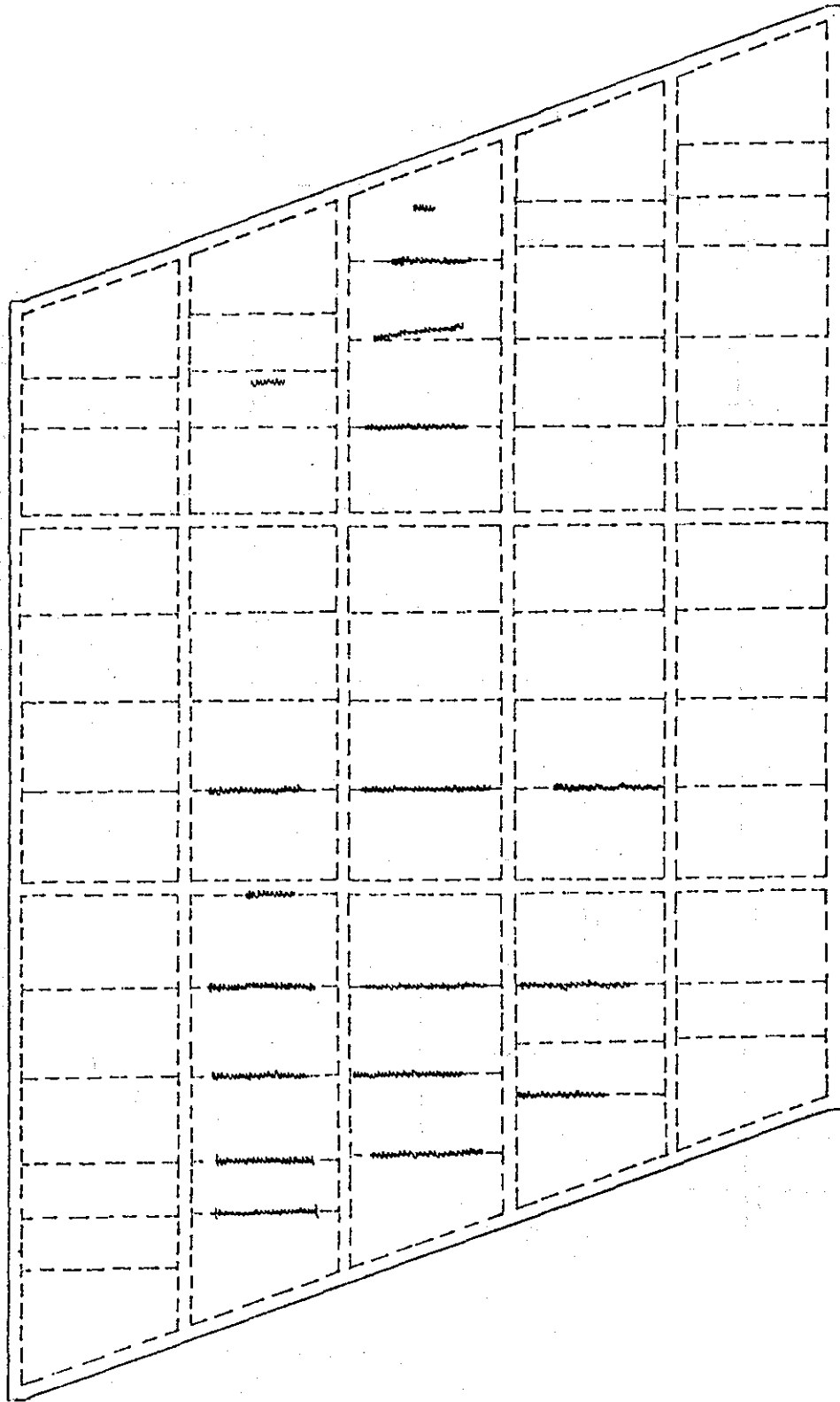

Figure A.2. Cracks in Cast-in-place Deck, Span 2NB.

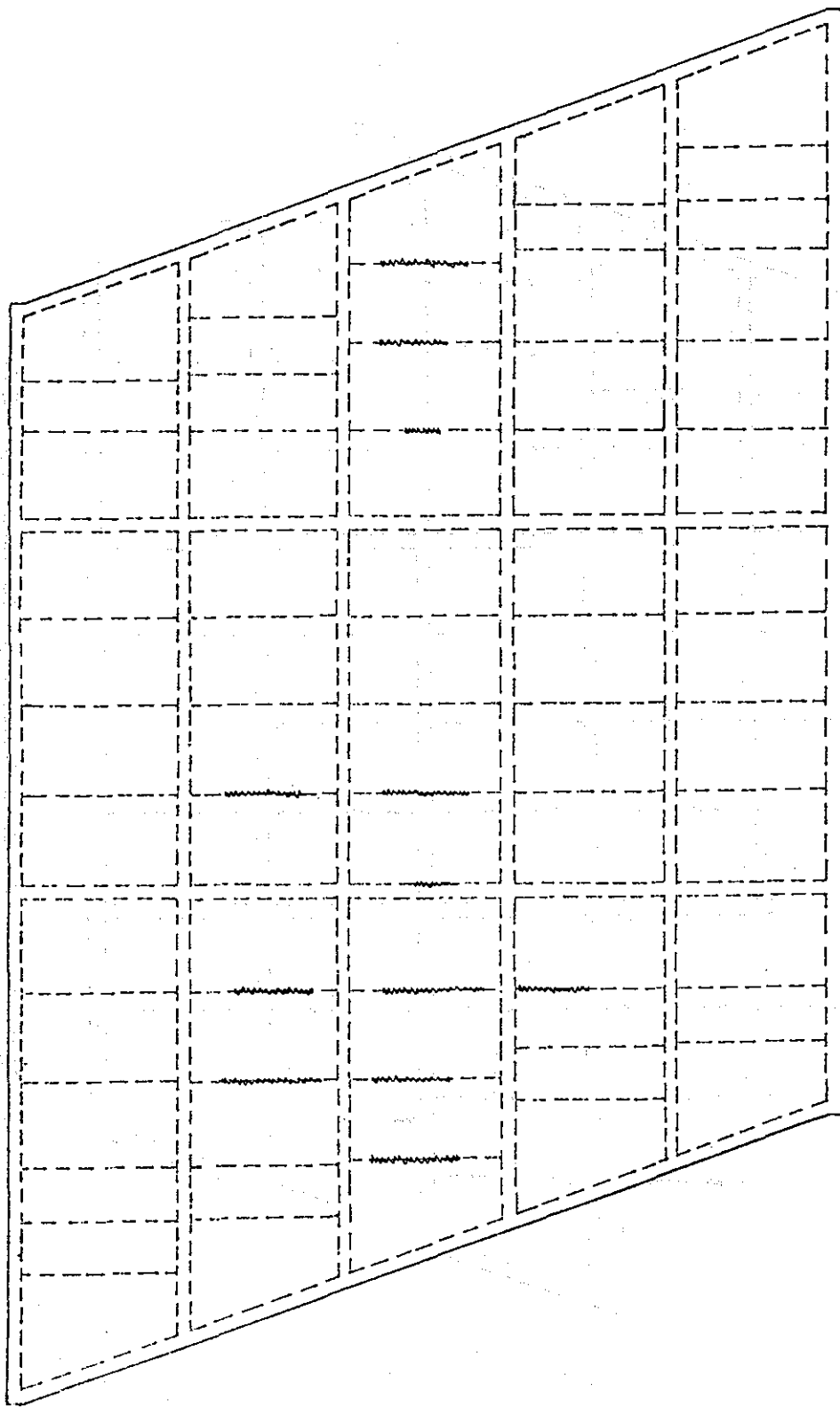

Figure A.3. Cracks in Cast-in-place Deck, Span 3NB.

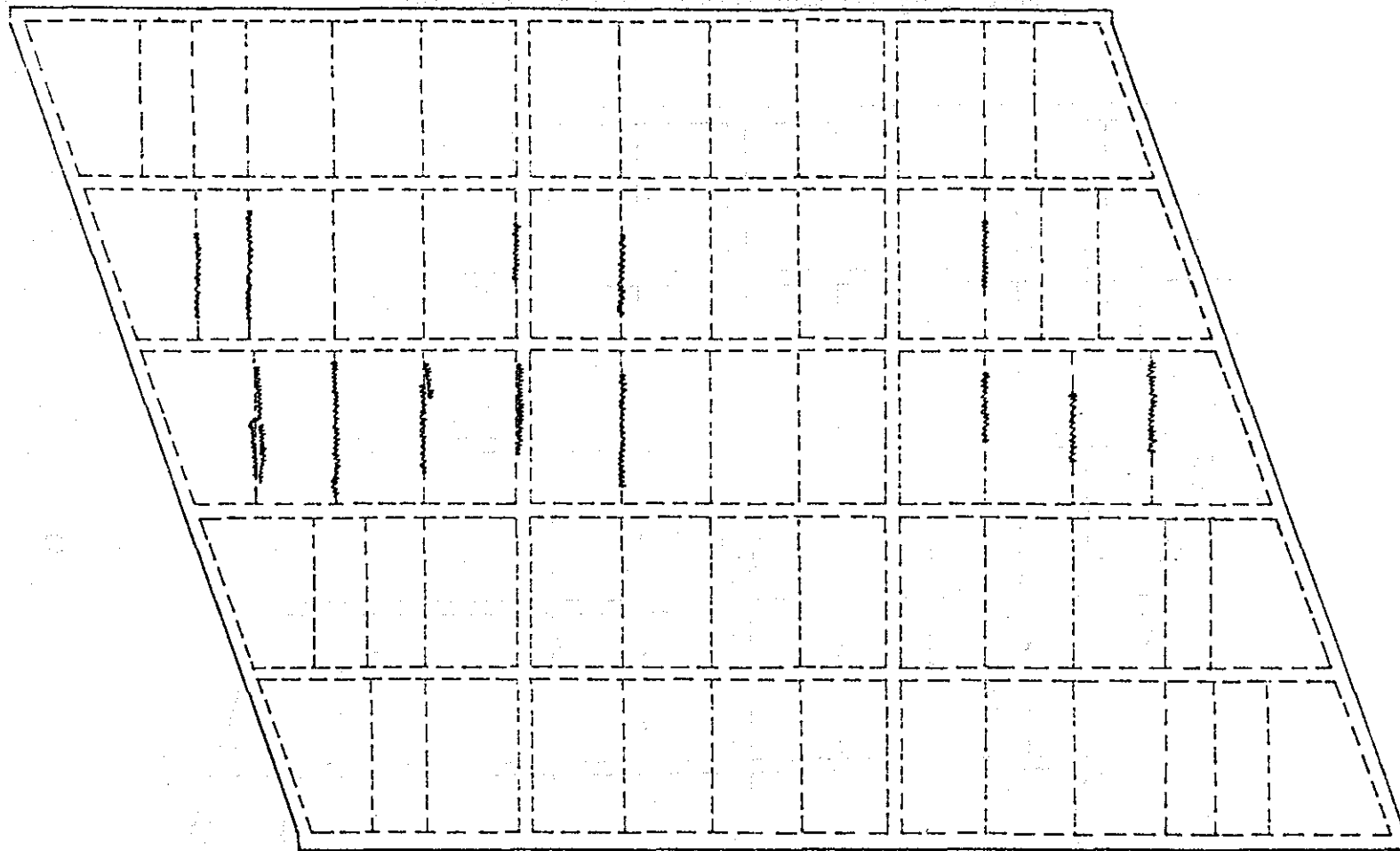

Figure A.4. Cracks in Cast-in-place Deck, Span 4NB.

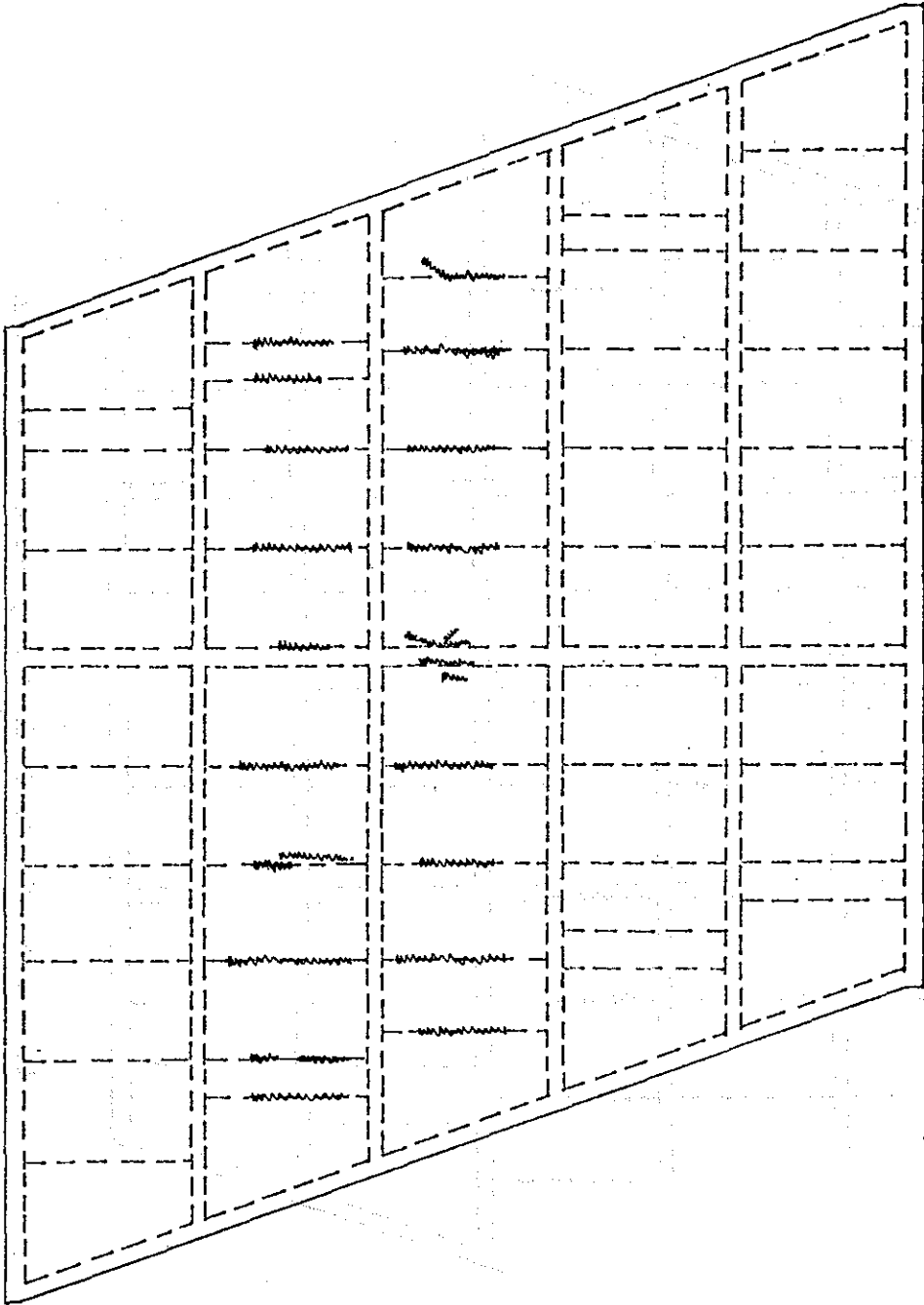

Figure A.5. Cracks in Cast-in-place Deck, Span 5NB.

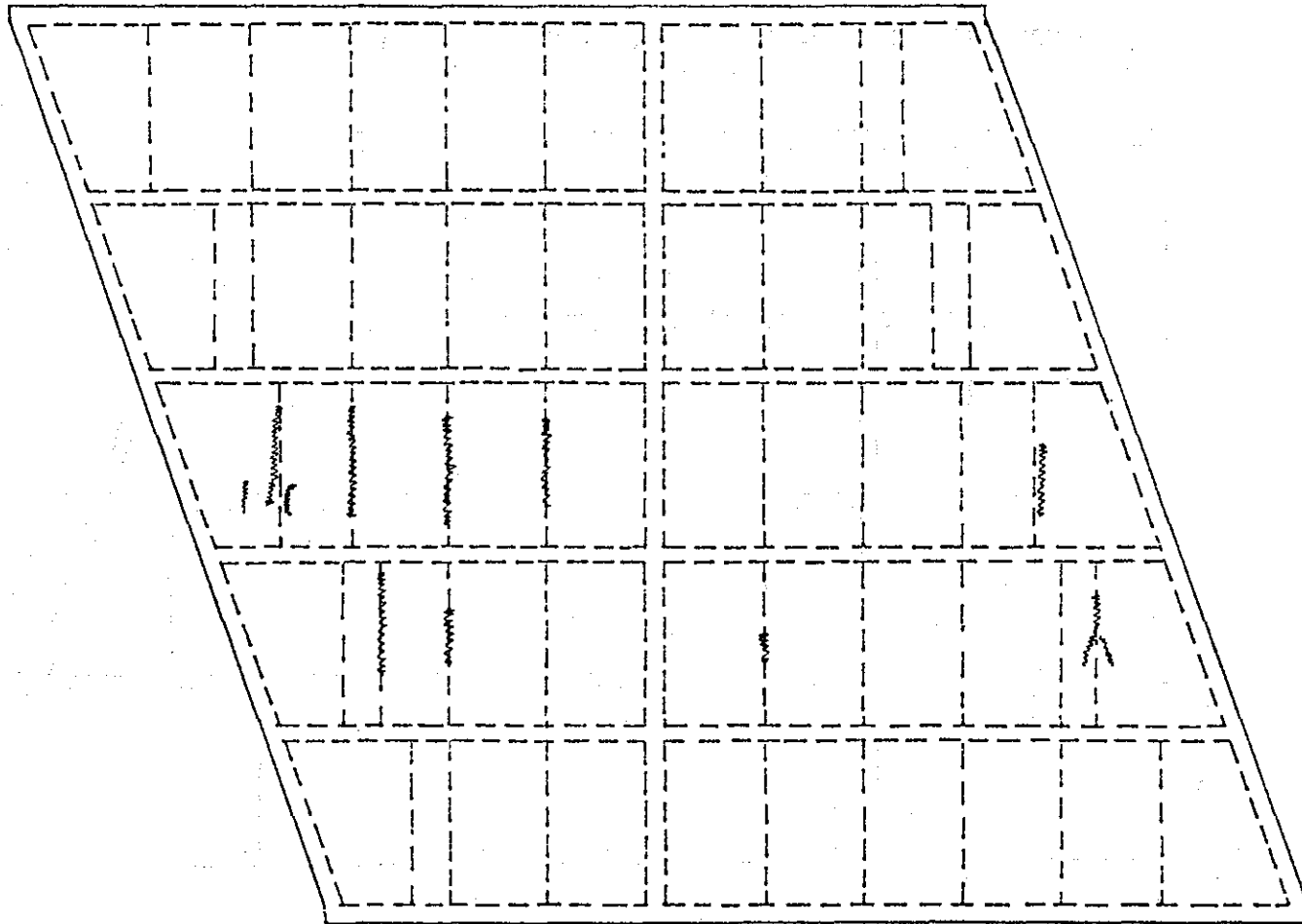

Figure A.6. Cracks in Cast-in-place Deck, Span 1SB.

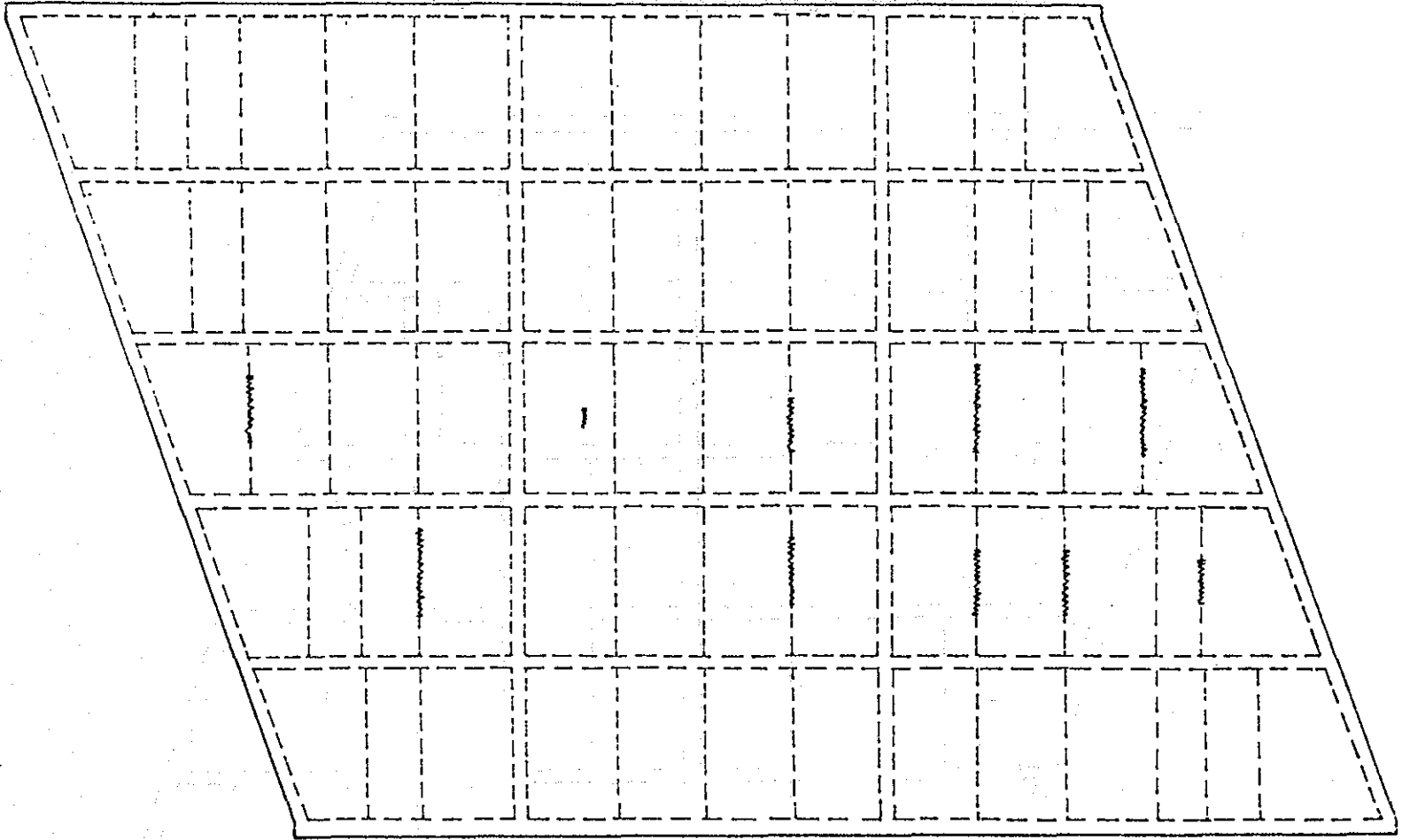

Figure A.7. Cracks in Cast-in-place Deck, Span 2SB .

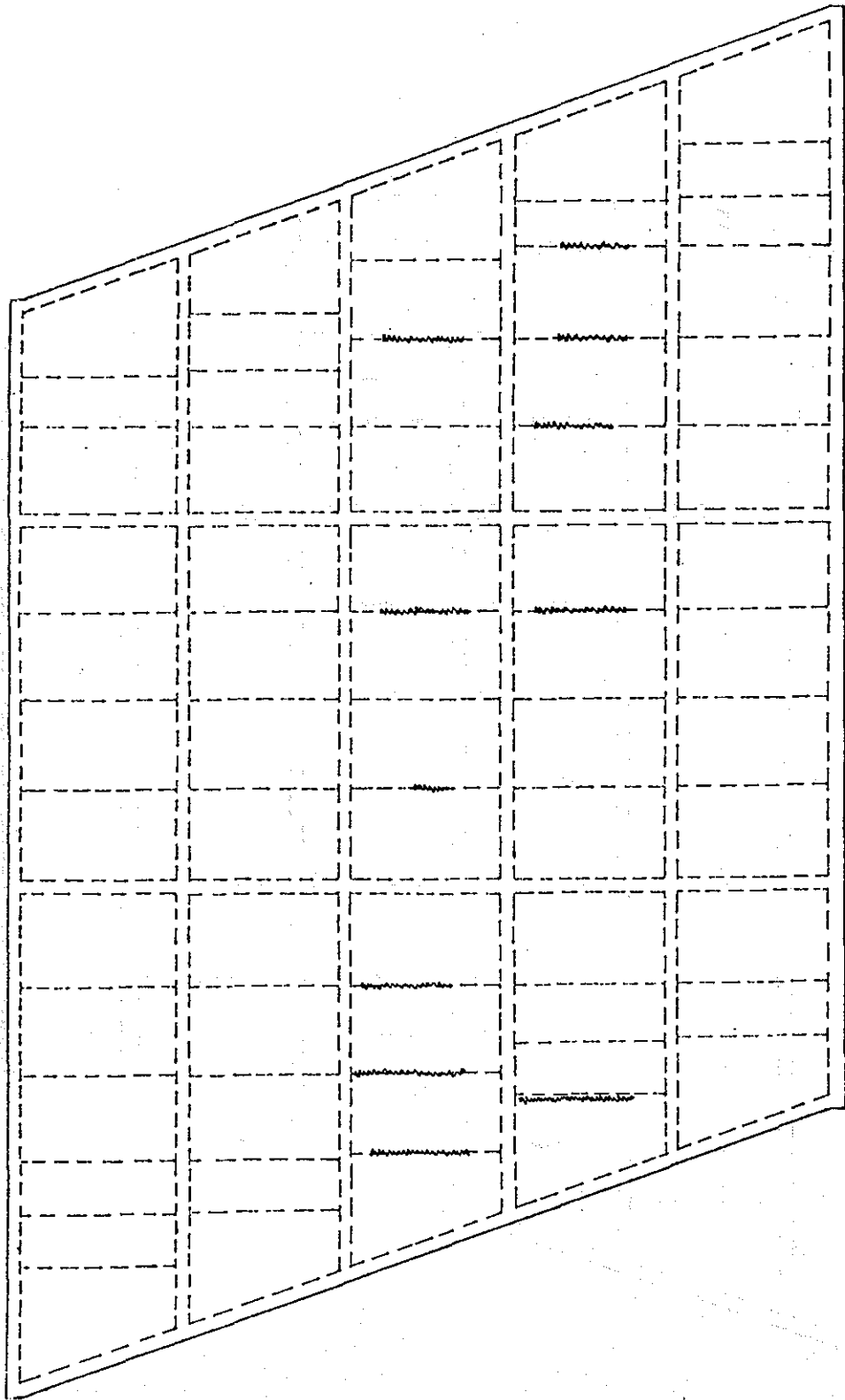

Figure A.8. Cracks in Cast-in-place Deck, Span 3SB.

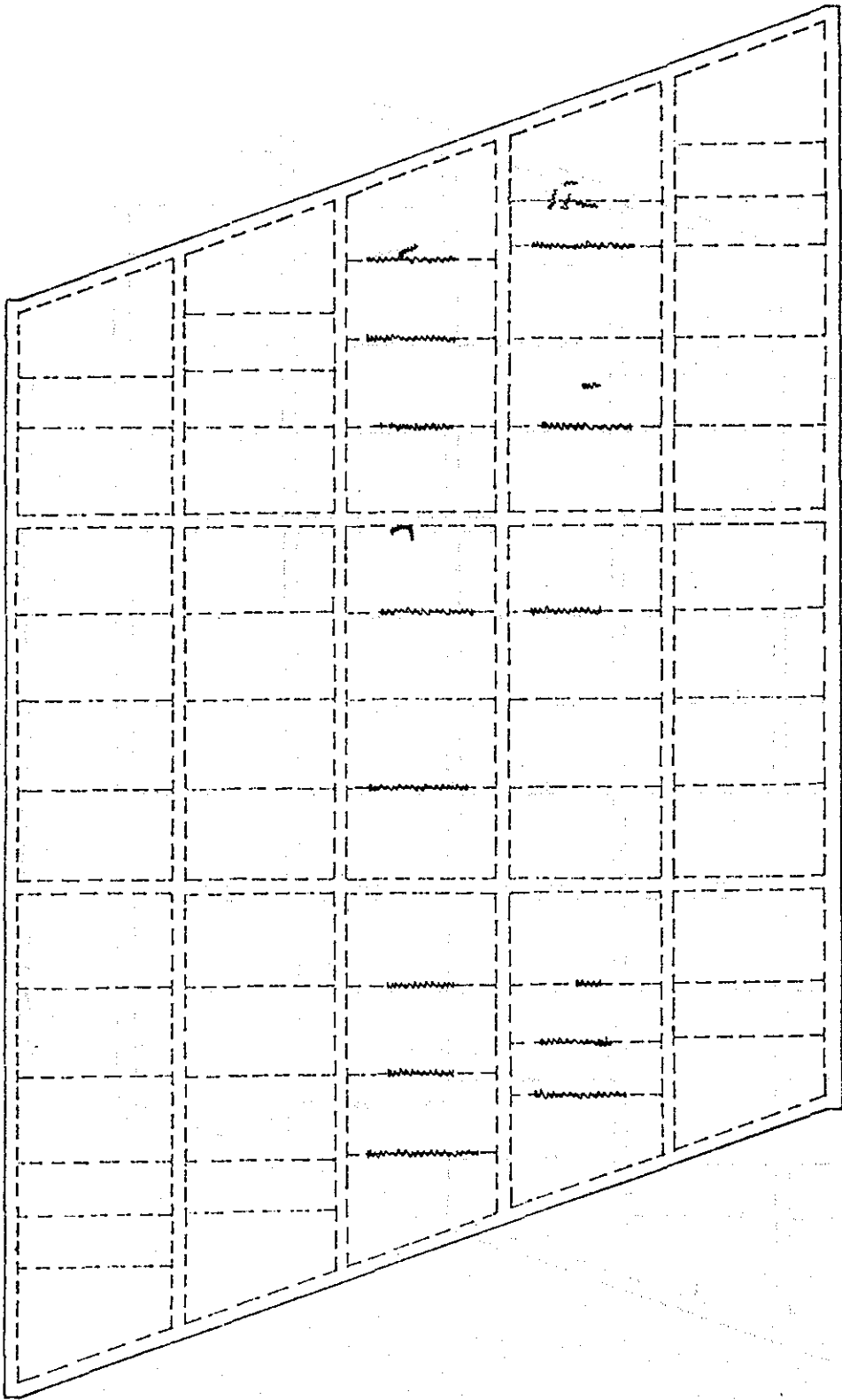

Figure A.9. Cracks in Cast-in-place Deck, Span 4SB.



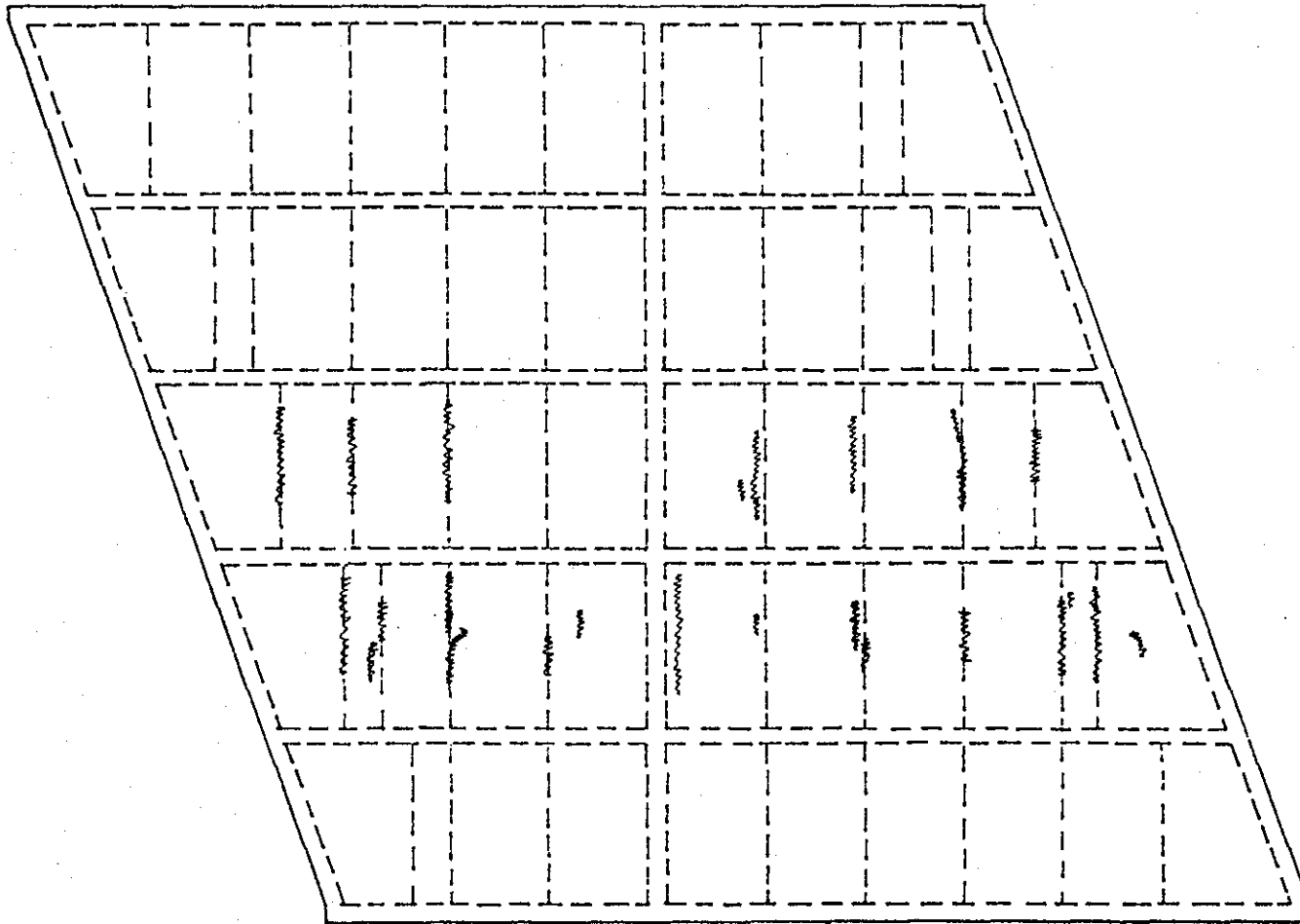

Figure A.10. Cracks in Cast-in-place Deck, Span 5SB.



APPENDIX B

LOAD TEST STRAIN READINGS

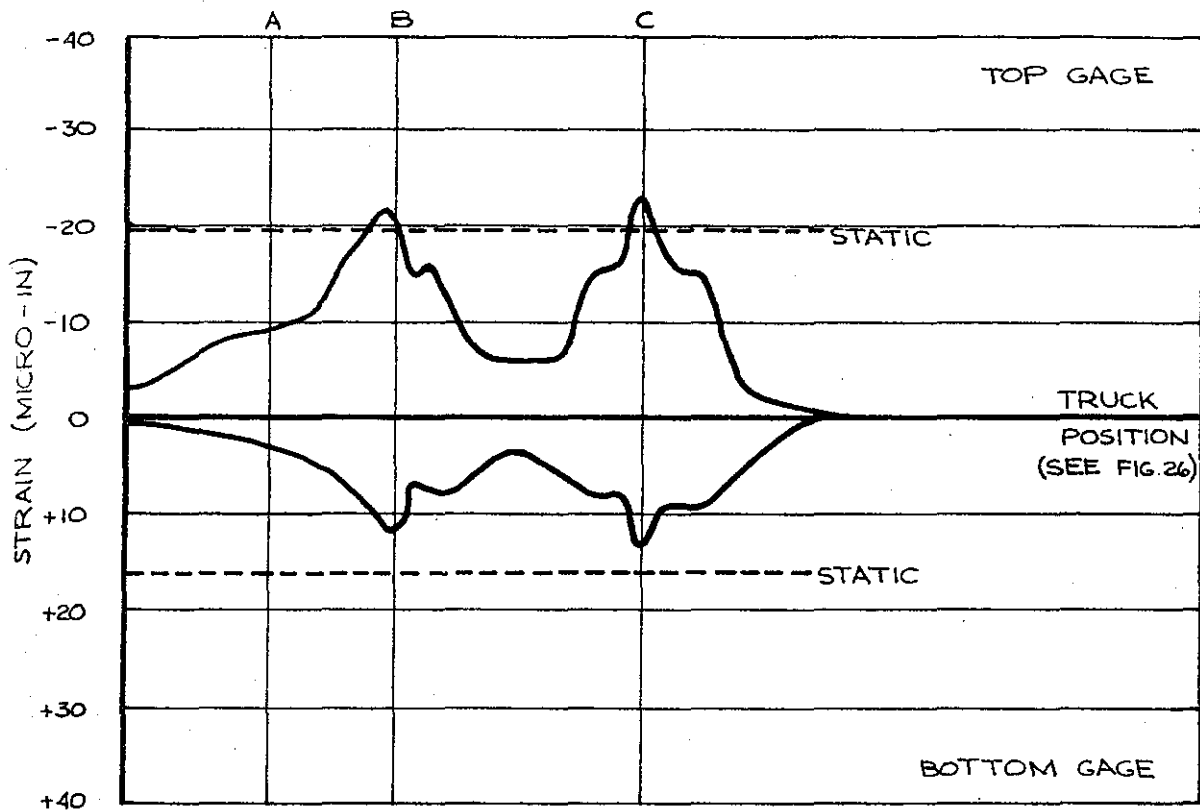

Figure B.1. Strain Readings, Top and Bottom Transverse Gages No. 1, Pattern No. 1.

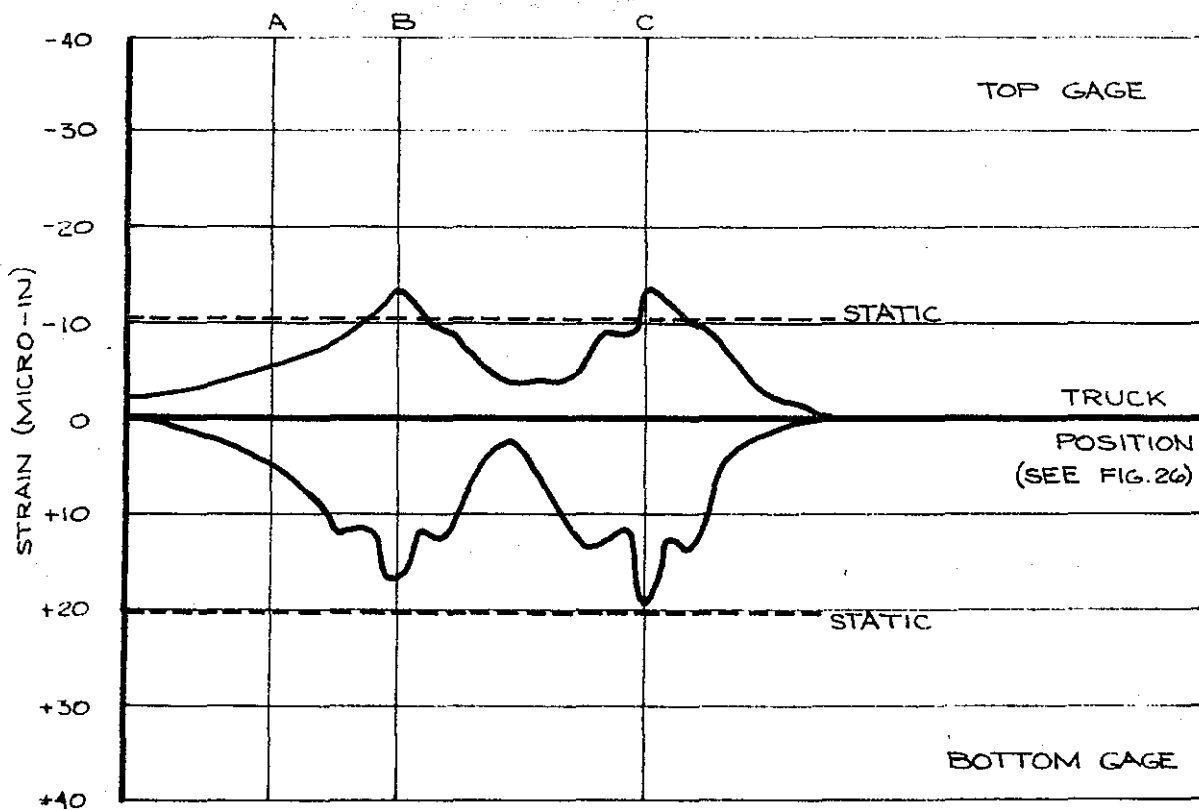

Figure B.2. Strain Readings, Top and Bottom Transverse Gages No. 2, Pattern No. 1.

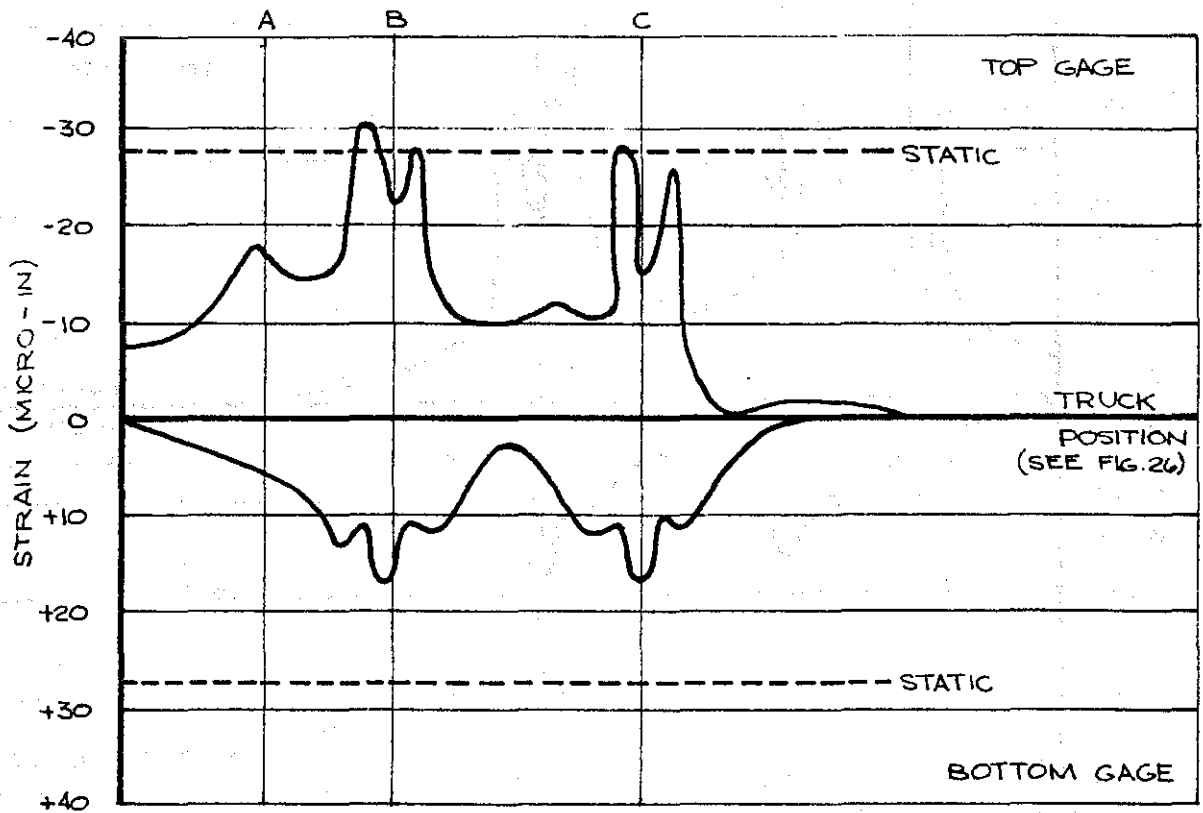

Figure B.3. Strain Readings, Top and Bottom Transverse Gages No. 3, Pattern No. 1.

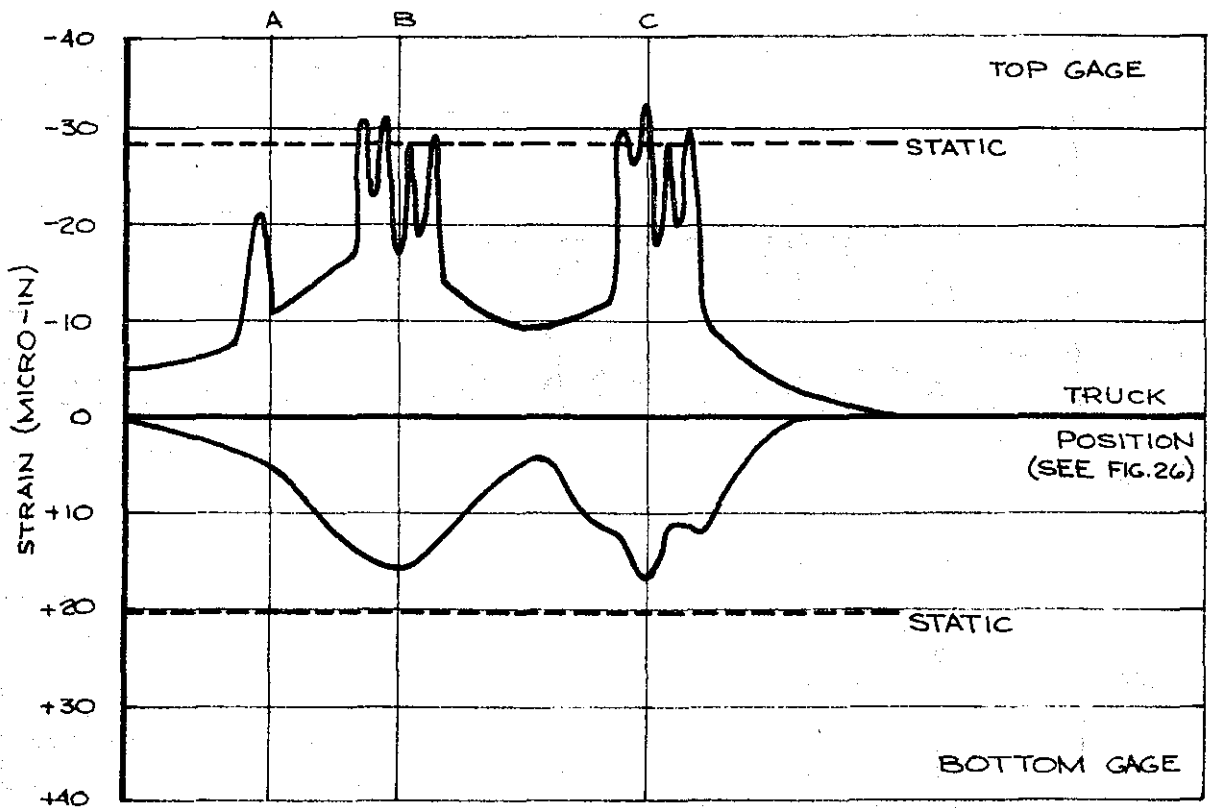

Figure B.4. Strain Readings, Top and Bottom Transverse Gages No. 4, Pattern No. 1.

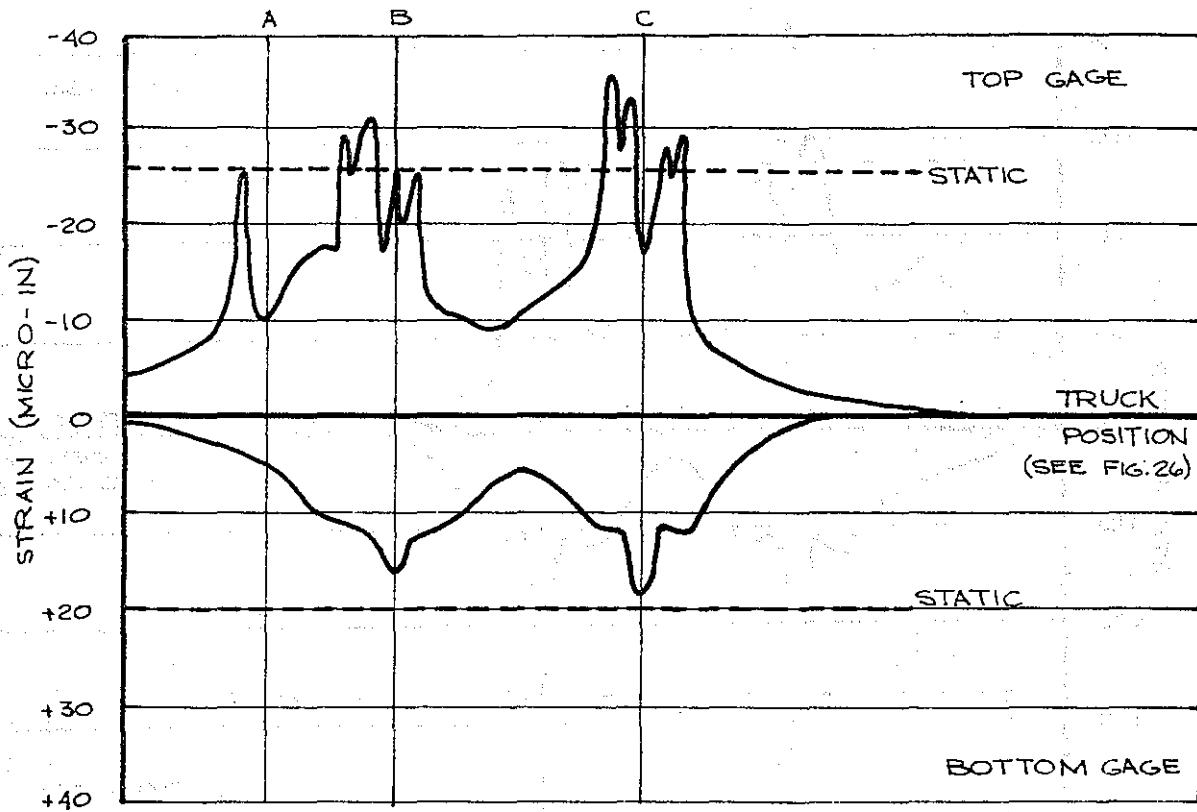

Figure B.5. Strain Readings, Top and Bottom Transverse Gages No. 5, Pattern No. 1.

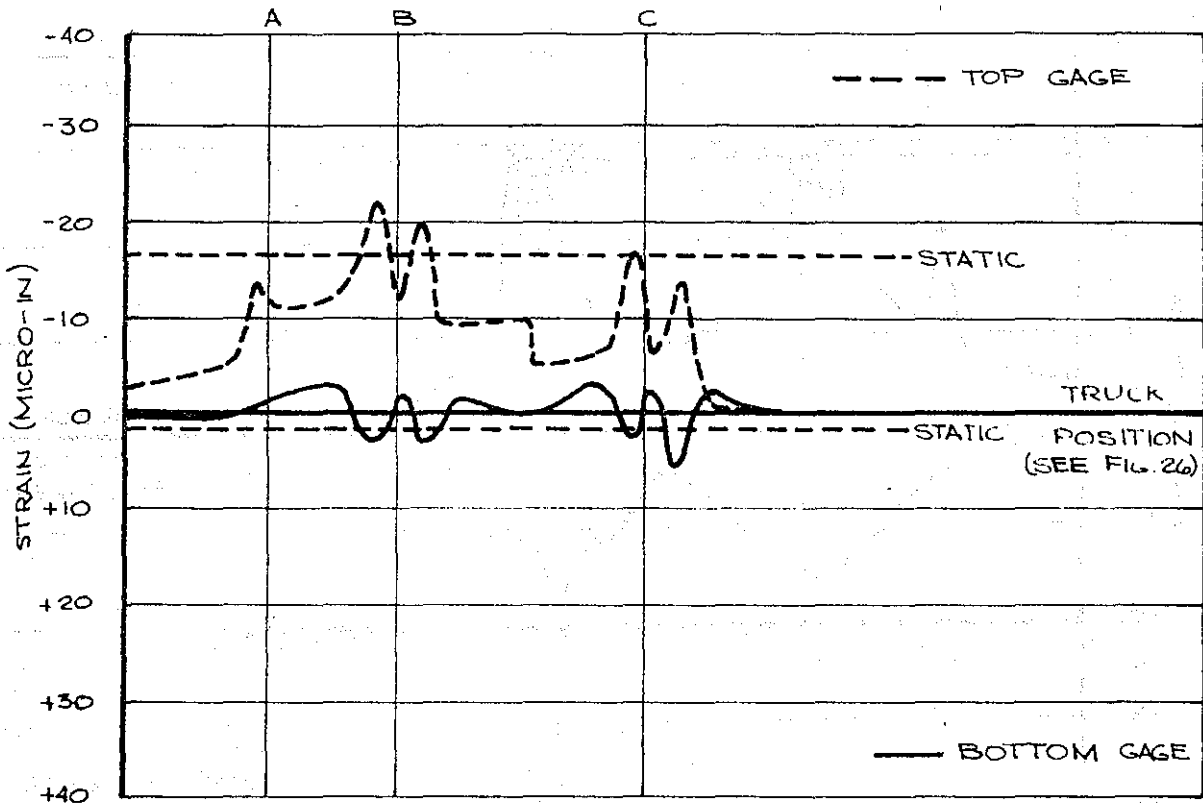

Figure B.6. Strain Readings, Top and Bottom Longitudinal Gages No. 6, Pattern No. 1.

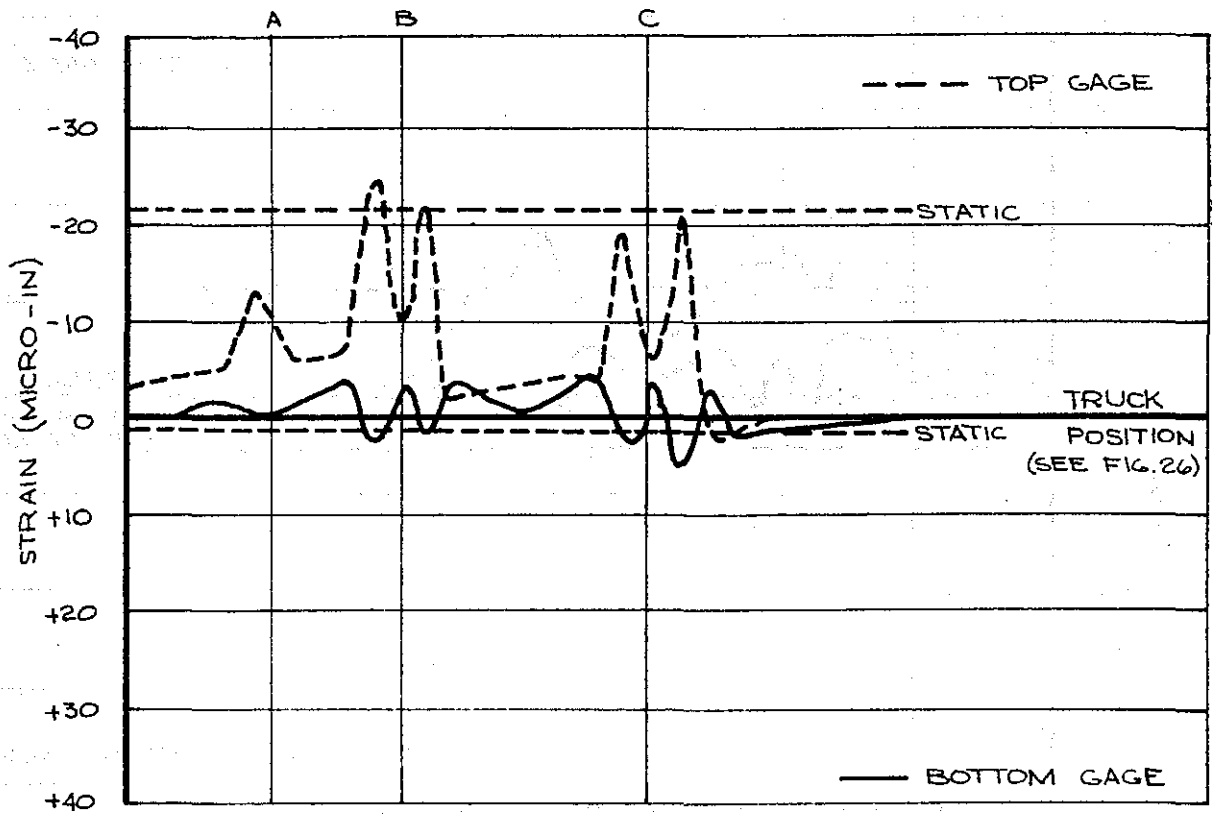

Figure B.7. Strain Readings, Top and Bottom Longitudinal Gages No. 7, Pattern No. 1.

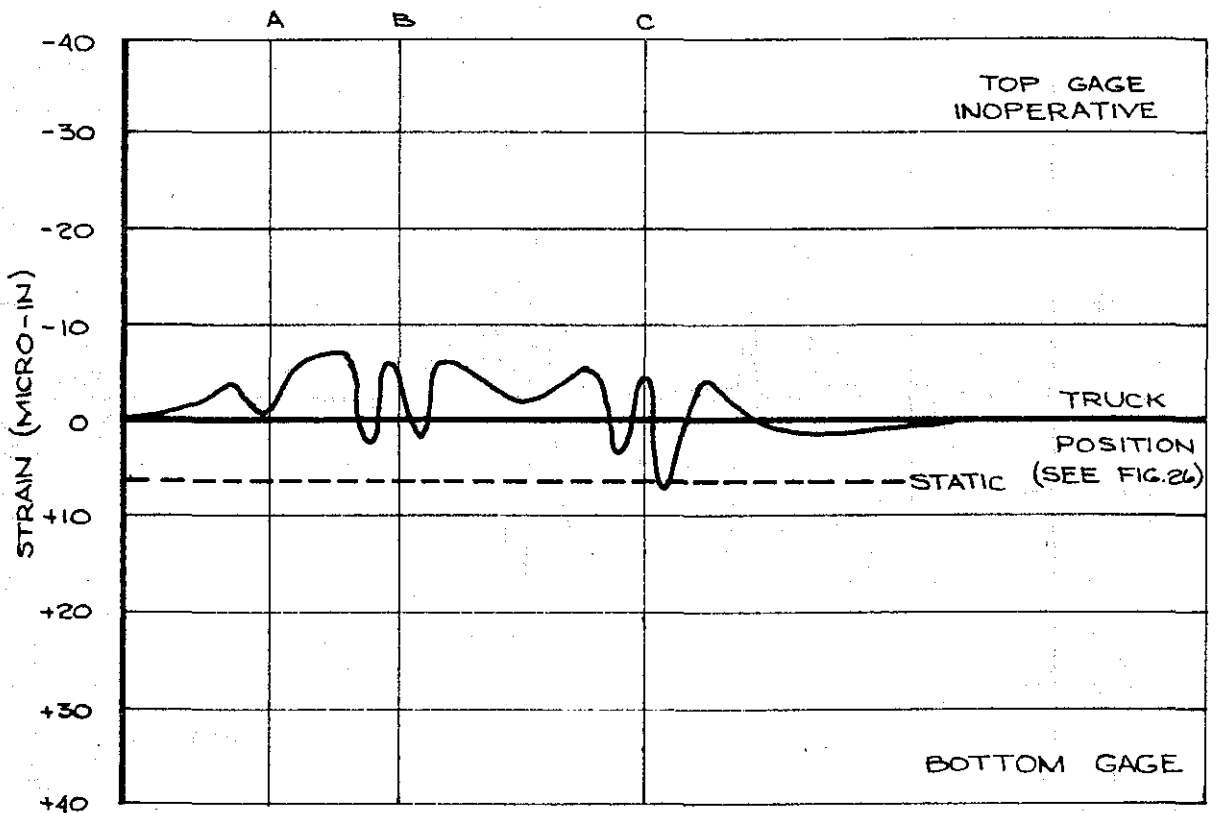

Figure B.8. Strain Readings, Bottom Longitudinal Gage No. 8 Pattern No. 1.

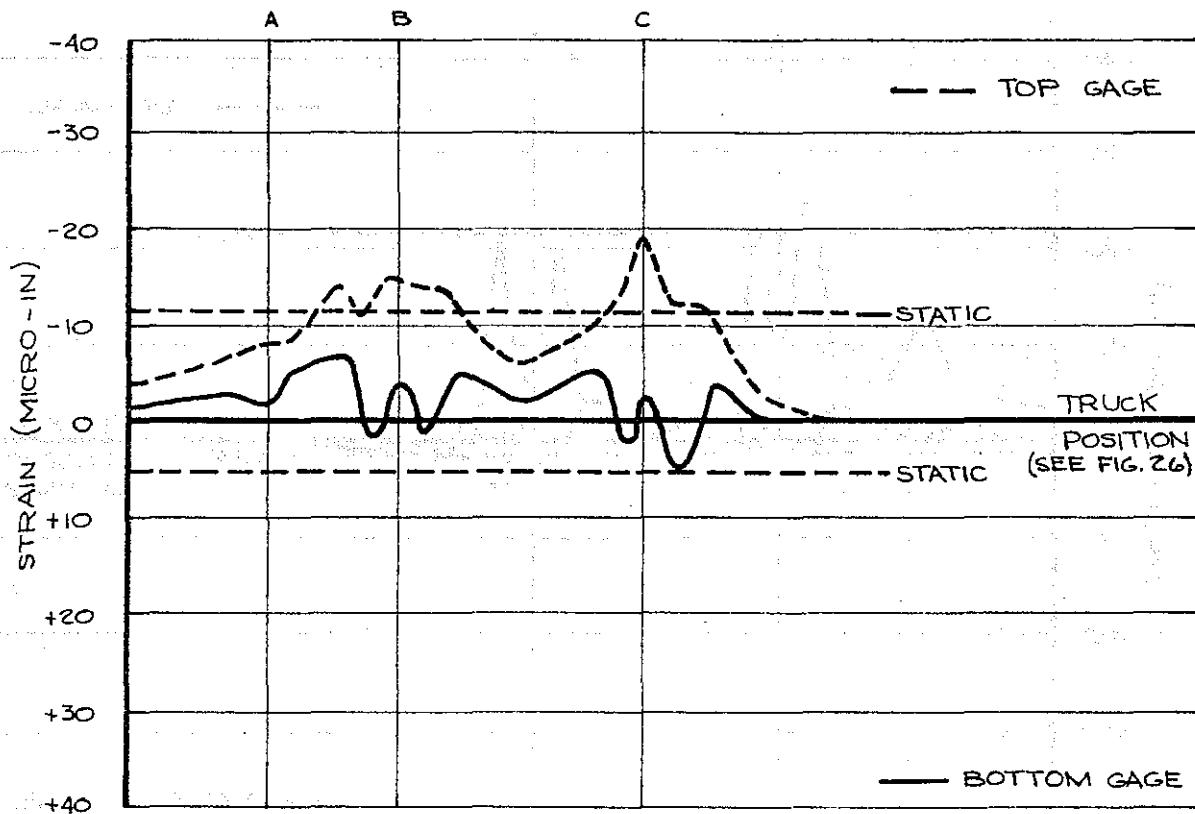

Figure B.9. Strain Readings, Top and Bottom Longitudinal Gages No. 9, Pattern No. 1.

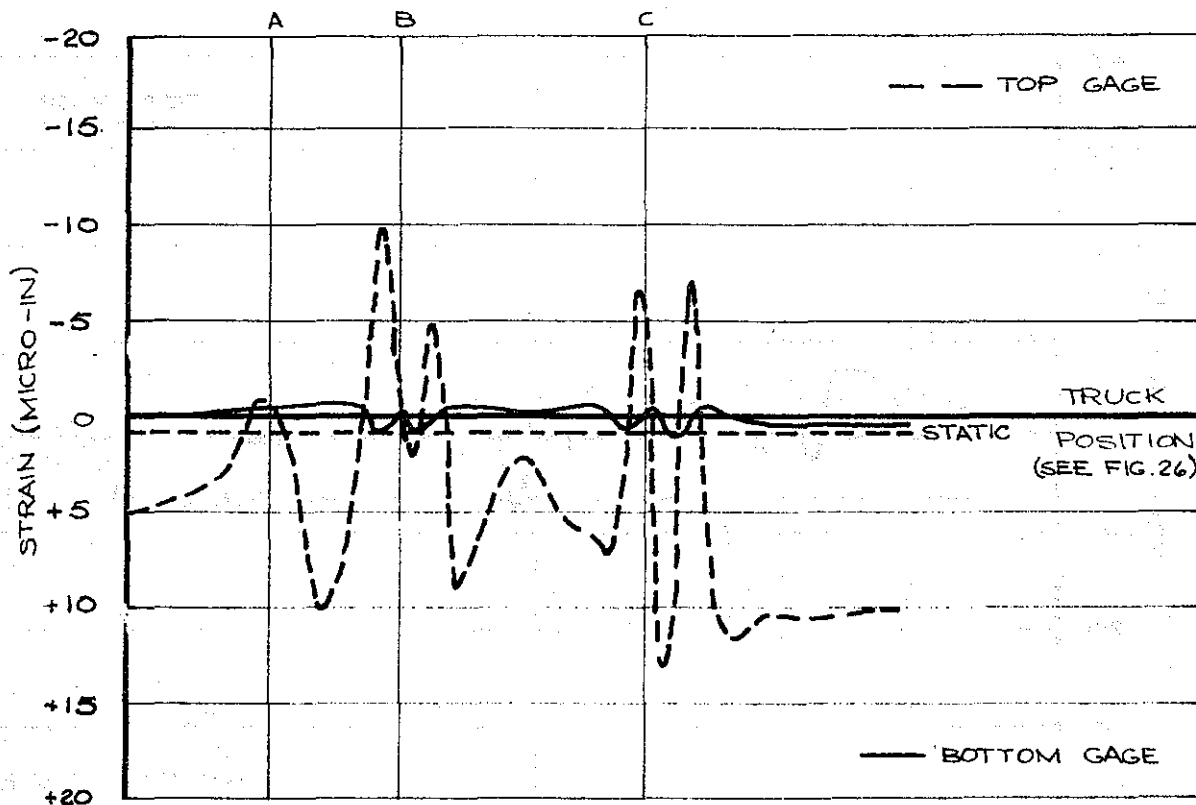

Figure B.10. Strain Readings, Top and Bottom Longitudinal Gages No. 10, Pattern No. 1.



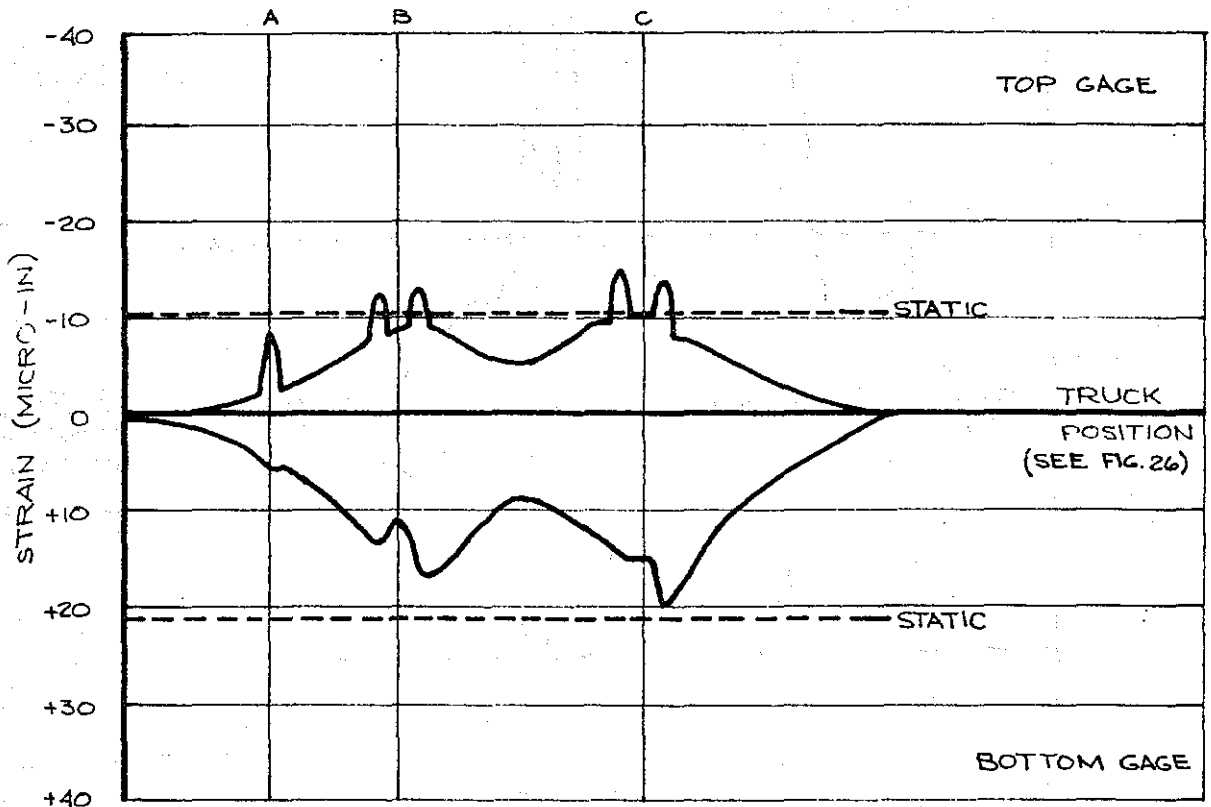

Figure B.11. Strain Readings, Top and Bottom Transverse Gages No. 1, Pattern No. 2.

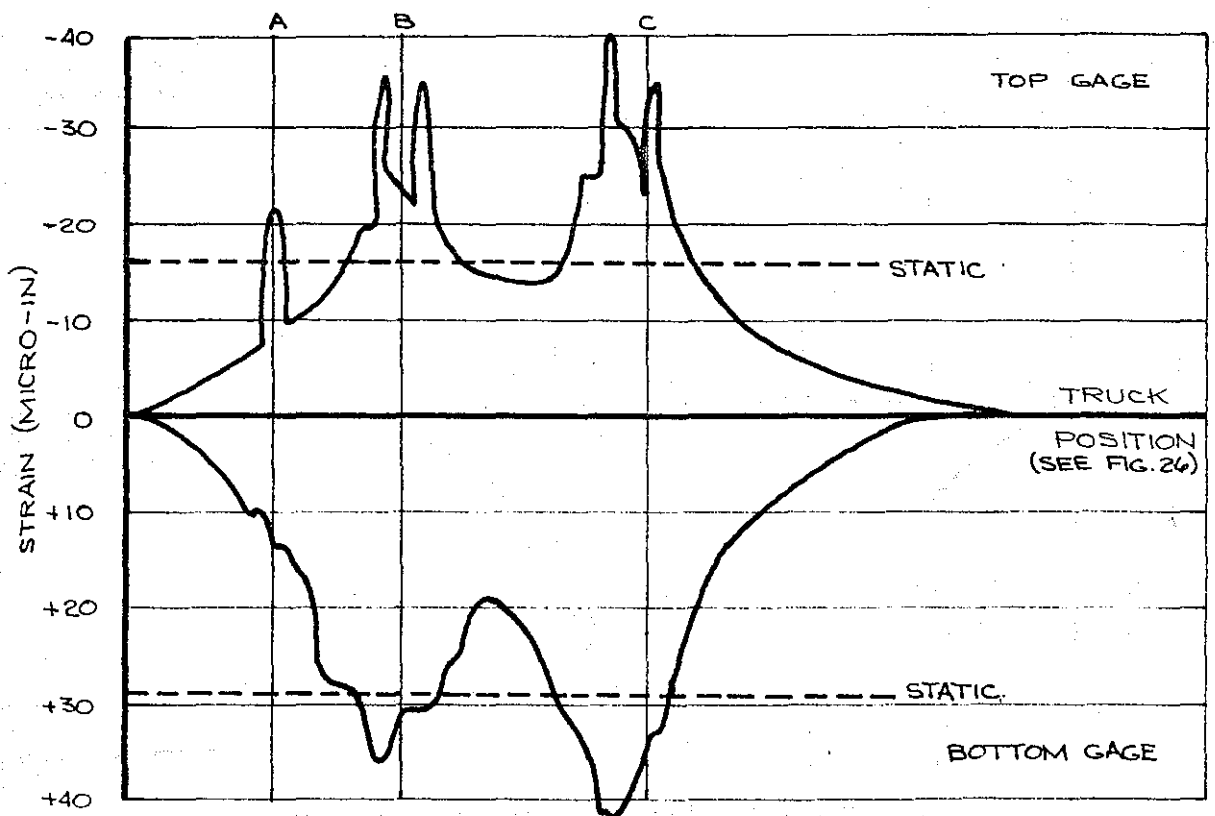

Figure B.12. Strain Readings, Top and Bottom Transverse Gages No. 2, Pattern No. 2.

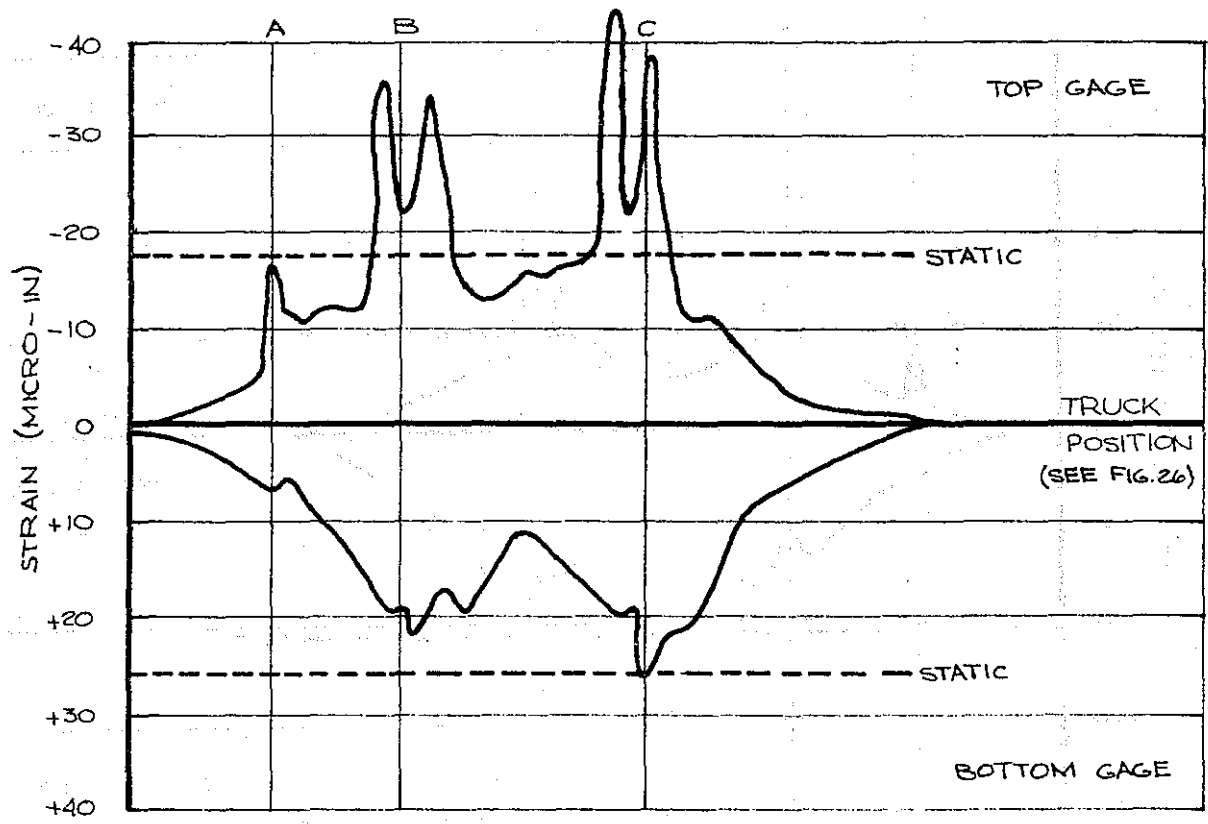

Figure B.13. Strain Readings, Top and Bottom Transverse Gages No. 3, Pattern No. 2.

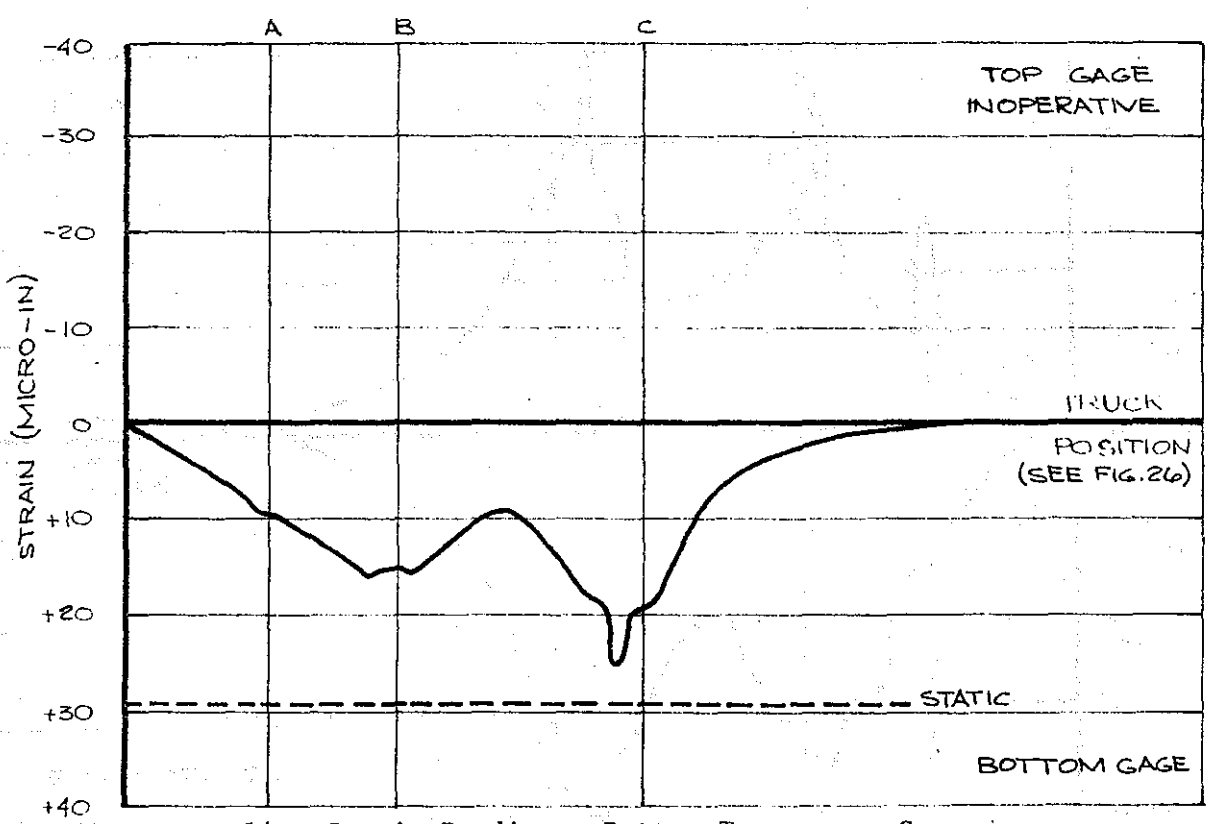

Figure B.14. Strain Readings, Bottom Transverse Gages No. 4, Pattern No. 2.

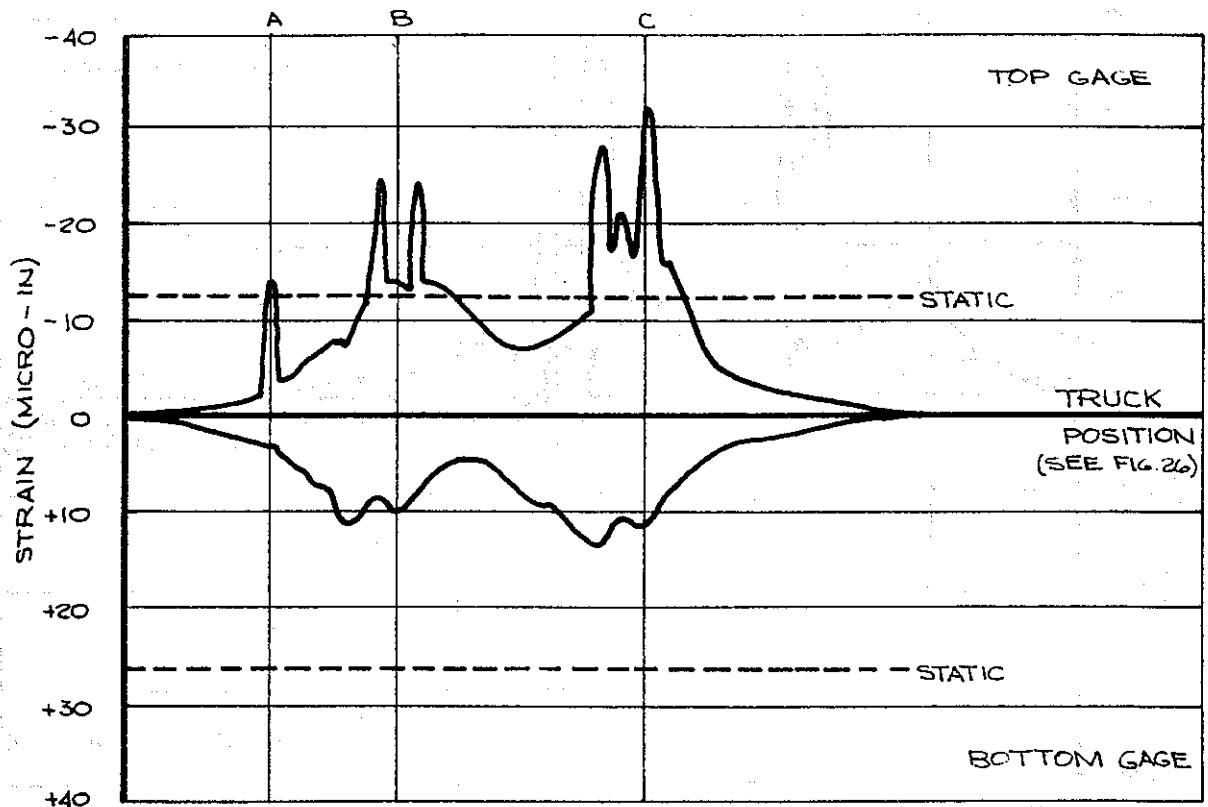

Figure B.15. Strain Readings, Top and Bottom Transverse Gages No. 5, Pattern No. 2.

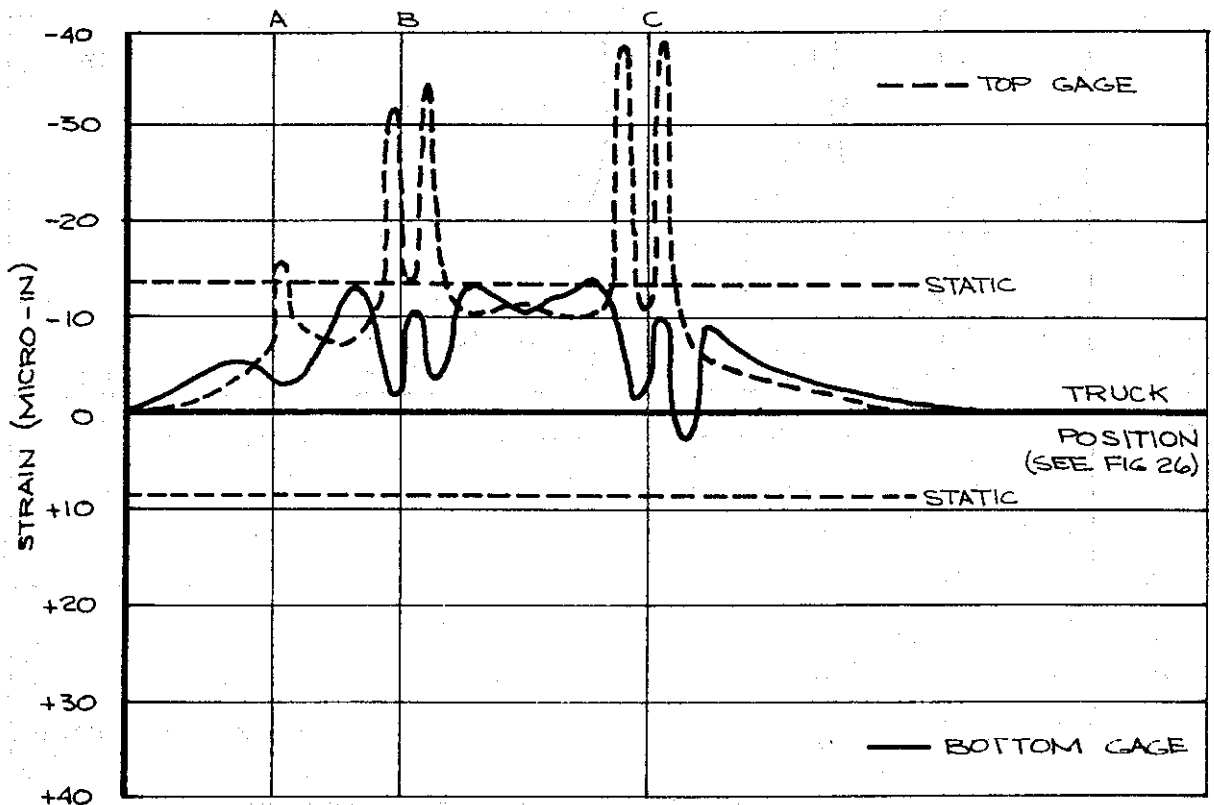

Figure B.16. Strain Readings, Top and Bottom Longitudinal Gages No. 6, Pattern No. 2.

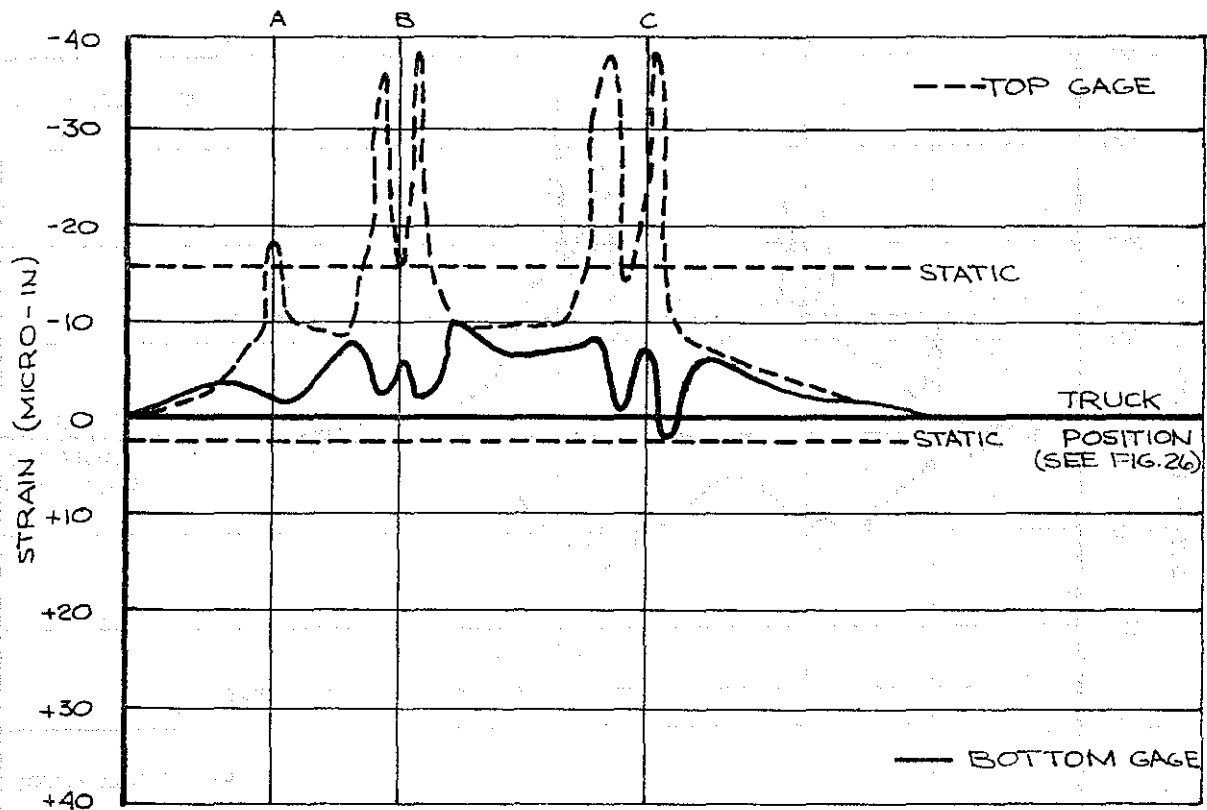

Figure B.17. Strain Readings, Top and Bottom Longitudinal Gages No. 7, Pattern No. 2.

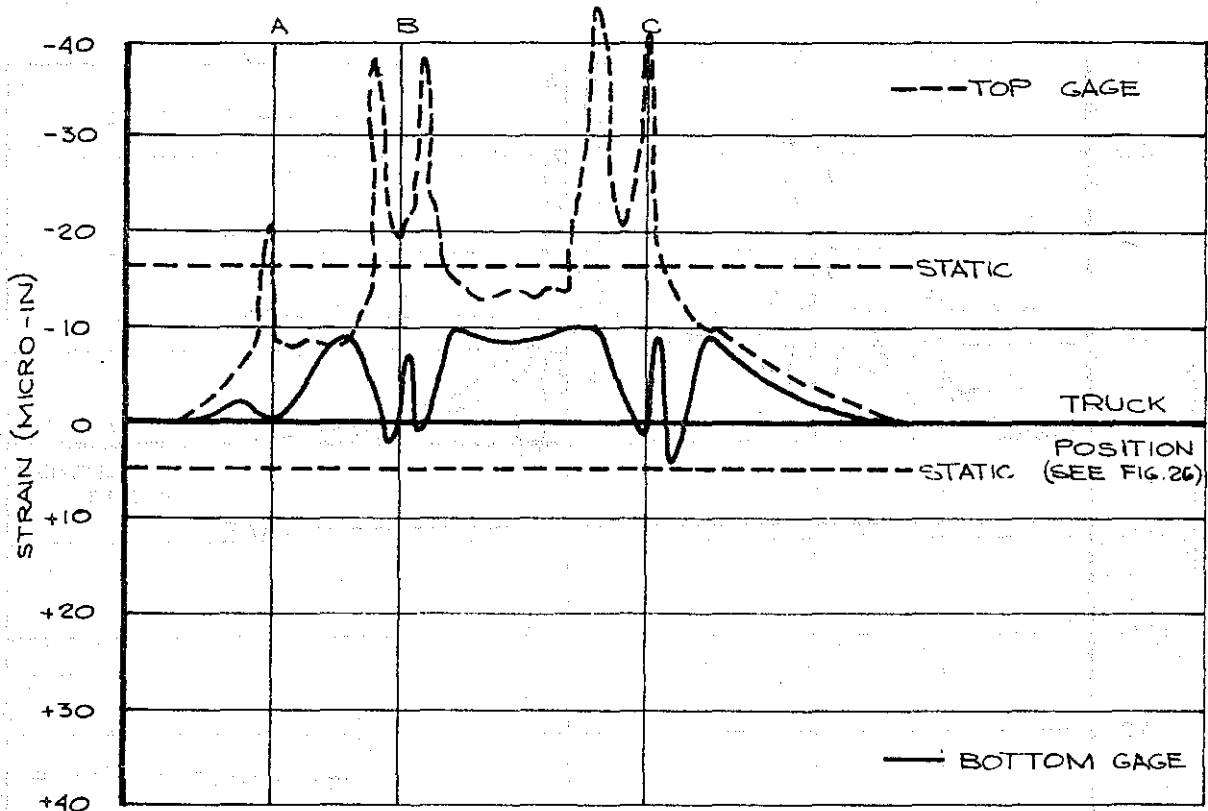

Figure B.18. Strain Readings, Top and Bottom Longitudinal Gages No. 8, Pattern No. 2.

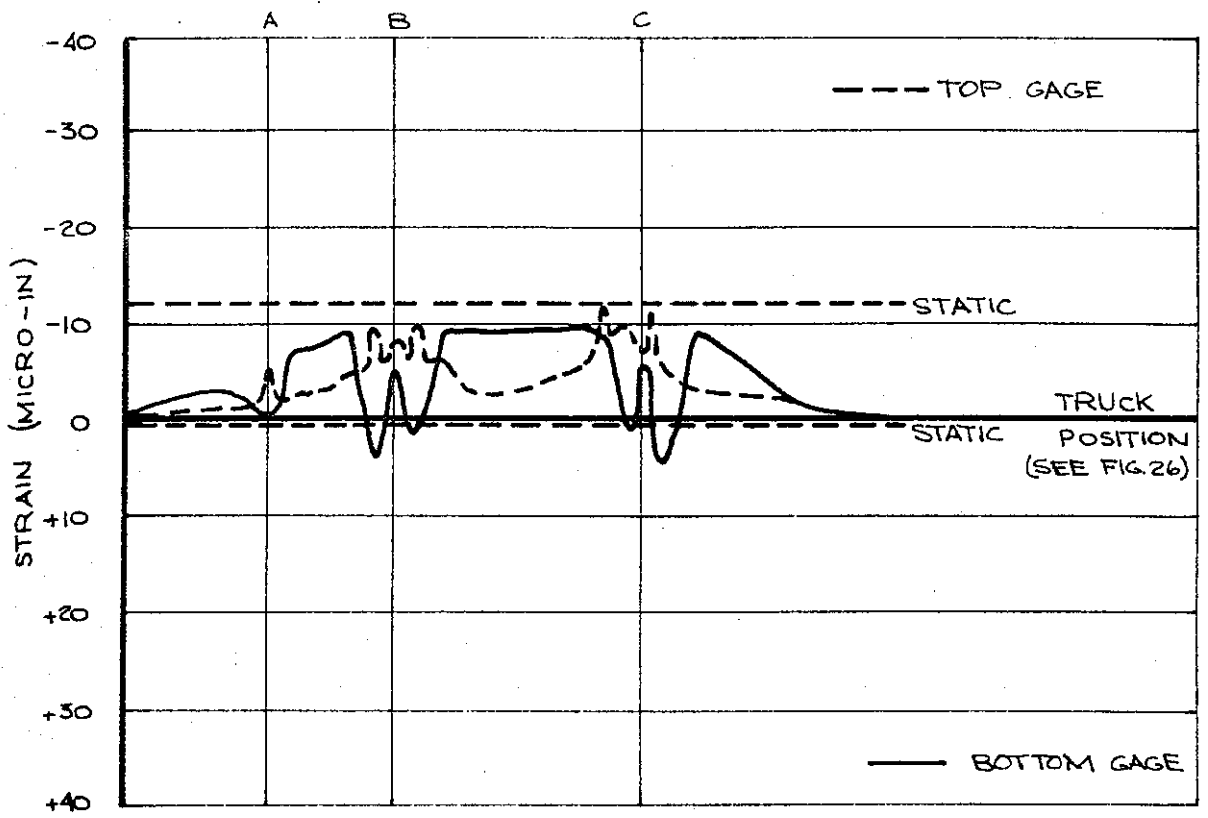

Figure B.19. Strain Readings, Top and Bottom Longitudinal Gages No. 9, Pattern No. 2 .

