

1. Report No. FHWA/TX-95/1379-1		2. Government Accession No.		3. Recipient's Catalog No.	
4. Title and Subtitle TEMPORARY EROSION CONTROL MEASURES DESIGN GUIDELINES FOR TXDOT				5. Report Date November 1994	
				6. Performing Organization Code	
7. Author(s) Sally H. Godfrey and Jana P. Long				8. Performing Organization Report No. Research Report 1379-1	
9. Performing Organization Name and Address Texas Transportation Institute The Texas A&M University System College Station, Texas 77843-3135				10. Work Unit No. (TRAIS)	
				11. Contract or Grant No. Study No. 0-1379	
12. Sponsoring Agency Name and Address Texas Department of Transportation Research and Technology Transfer Office P. O. Box 5080 Austin, Texas 78763-5080				13. Type of Report and Period Covered Interim: September 1993-August 1994	
				14. Sponsoring Agency Code	
15. Supplementary Notes Research performed in cooperation with the Texas Department of Transportation and the U.S. Department of Transportation, Federal Highway Administration. Research Study Title: Temporary Erosion Control Methods					
16. Abstract Achieving the maximum environmental benefits of an entire project's lifetime (planning and design phase, construction and maintenance) has become an important goal for the Texas Department of Transportation (TxDOT). With the implementation of the Environmental Protection Agency's National Pollutant Discharge Elimination System (NPDES) permitting requirements in 1992, an increased awareness and pro-active stormwater management program has been developed in TxDOT. During the past twenty years, there has been a proliferation of erosion and sediment control products and methods developed by the erosion industry. Industry standards have not kept up with the rapid changes; therefore, education, testing, and applications vary across the country. Designers need to have the appropriate guidance to be able to meet the demands placed on them today. The researchers evaluated the difficulties encountered during the design and selection process for developing stormwater pollution prevention plans (SW3P) and provided guidance in the following areas: erosion and sediment control functions, application areas, nomenclature, steps to select measures, erosion principles, and erosion prediction factors. Design aids developed include the following: PC-based computer program for SW3P reporting and selection procedures and a final report that includes a glossary for cross-referencing other publications and updated VM and K reference tables.					
17. Key Words Temporary Erosion and Sediment Control, Stormwater Management for Construction Sites, Erosion Control Selection Program			18. Distribution Statement No restrictions. This document is available to the public through NTIS: National Technical Information Service 5285 Port Royal Road Springfield, Virginia 22161		
19. Security Classif.(of this report) Unclassified		20. Security Classif.(of this page) Unclassified		21. No. of Pages 114	22. Price

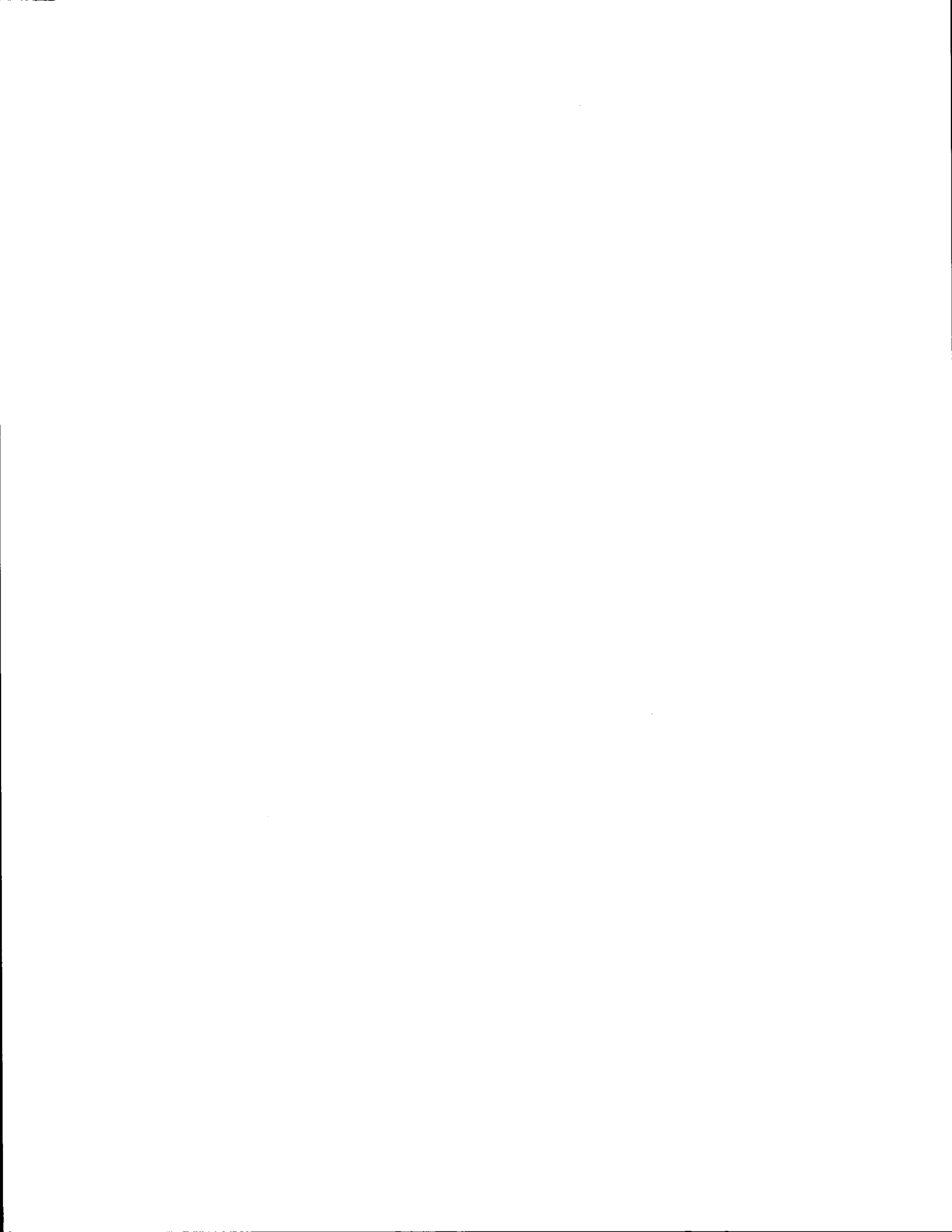

**TEMPORARY EROSION CONTROL MEASURES**  
**DESIGN GUIDELINES FOR TXDOT**

by

Sally H. Godfrey, Landscape Architect  
Assistant Research Scientist  
Texas Transportation Institute

and

Jana P. Long  
Research Associate  
Texas Transportation Institute

Research Report 1379-1  
Research Study Number 0-1379  
Research Study Title: Temporary Erosion Control Methods

Sponsored by the  
Texas Department of Transportation  
In Cooperation with  
U.S. Department of Transportation  
Federal Highway Administration

November 1994

TEXAS TRANSPORTATION INSTITUTE  
The Texas A&M University System  
College Station, Texas 77843-3135



## IMPLEMENTATION STATEMENT

The findings and products from this work will have immediate application in the planning and design of stormwater management for construction (and maintenance) sites. Methods to develop design aids that directly relate to current approved TxDOT best management practices ensure the deliverables used in the design process. Problems encountered in the field were addressed by developing guidance on the process of selecting temporary, temporary/permanent, and permanent erosion and sediment control measures.

The researchers accomplished these objectives by identifying problems in the field, evaluating current TxDOT design methodology, and reviewing literature and research data to produce useful design aids. A user-friendly PC-based computer program was developed for distribution to each district by TxDOT that should accompany this report and the TxDOT Stormwater Guidelines for Construction Activities. The benefits of the computer program is the level of quality control achievable in the process of selecting erosion and sediment control practices appropriate for each district in TxDOT based upon the function and application area. Information concerning nonstructural (vegetative) controls is specific for each district and guides the designer to selecting the most appropriate seeding mixtures. Soil erodibility indexes are available and reporting output for stormwater pollution prevention plans. Design flexibility is accomplished by the quick generation of information available to the designer. Together these documents and program will be a beneficial and cost effective method for simplifying the selection process.

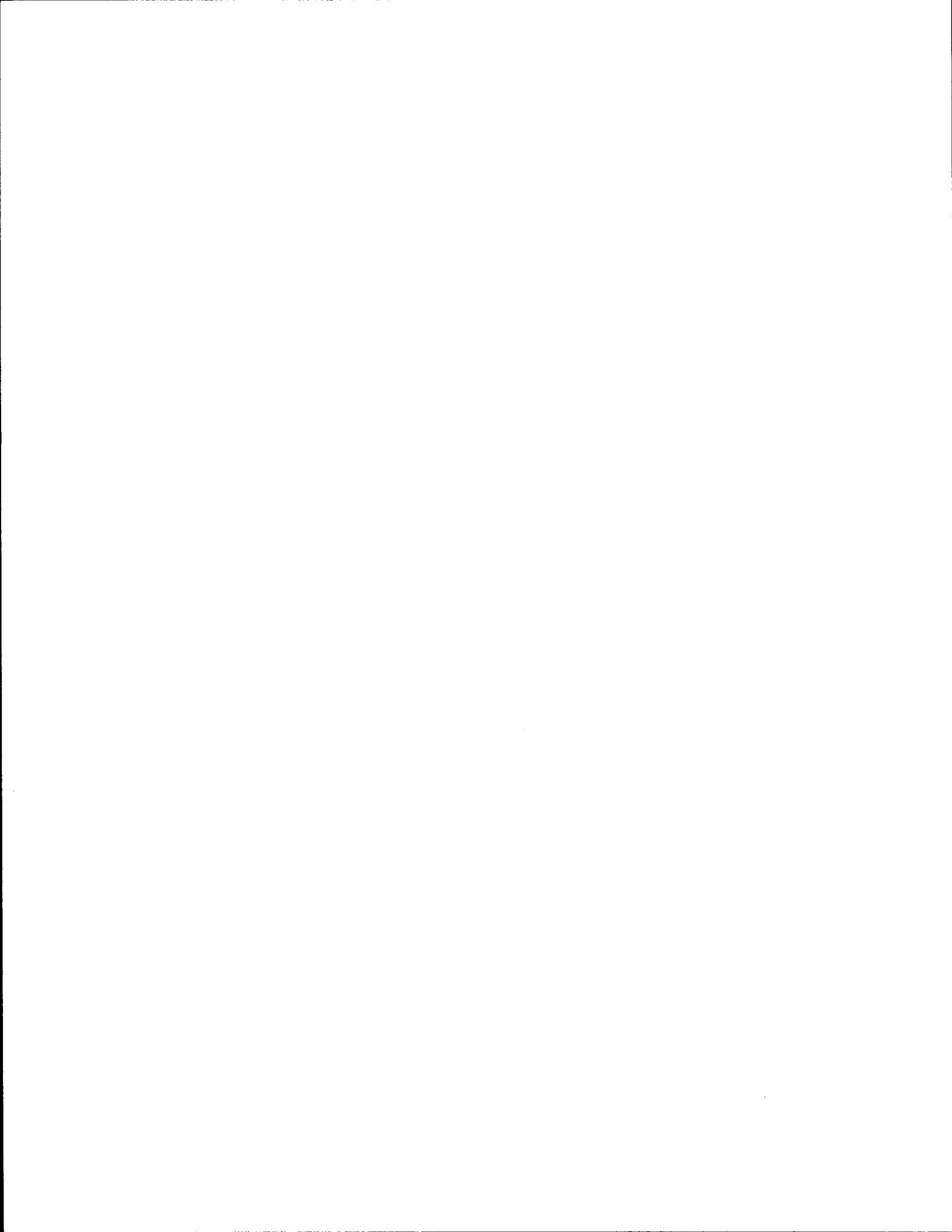

## **DISCLAIMER**

### **AUTHORS'S DISCLAIMER**

The contents of this report reflect the views of the authors who are responsible for the facts and the accuracy of the data presented herein. The contents do not necessarily reflect the official view or policies of the Texas Department of Transportation (TxDOT), or the Federal Highway Administration (FHWA). This report does not constitute a standard, specification, or regulation.

### **PATENT DISCLAIMER**

There was no invention or discovery conceived or first actually reduced to practice in the course of or under this contract, including any art, method, process, machine, manufacture, design or composition of matter, or any new useful improvement thereof, or any variety of plant, which is or may be patentable under the patent laws of the United States of American or any foreign country.

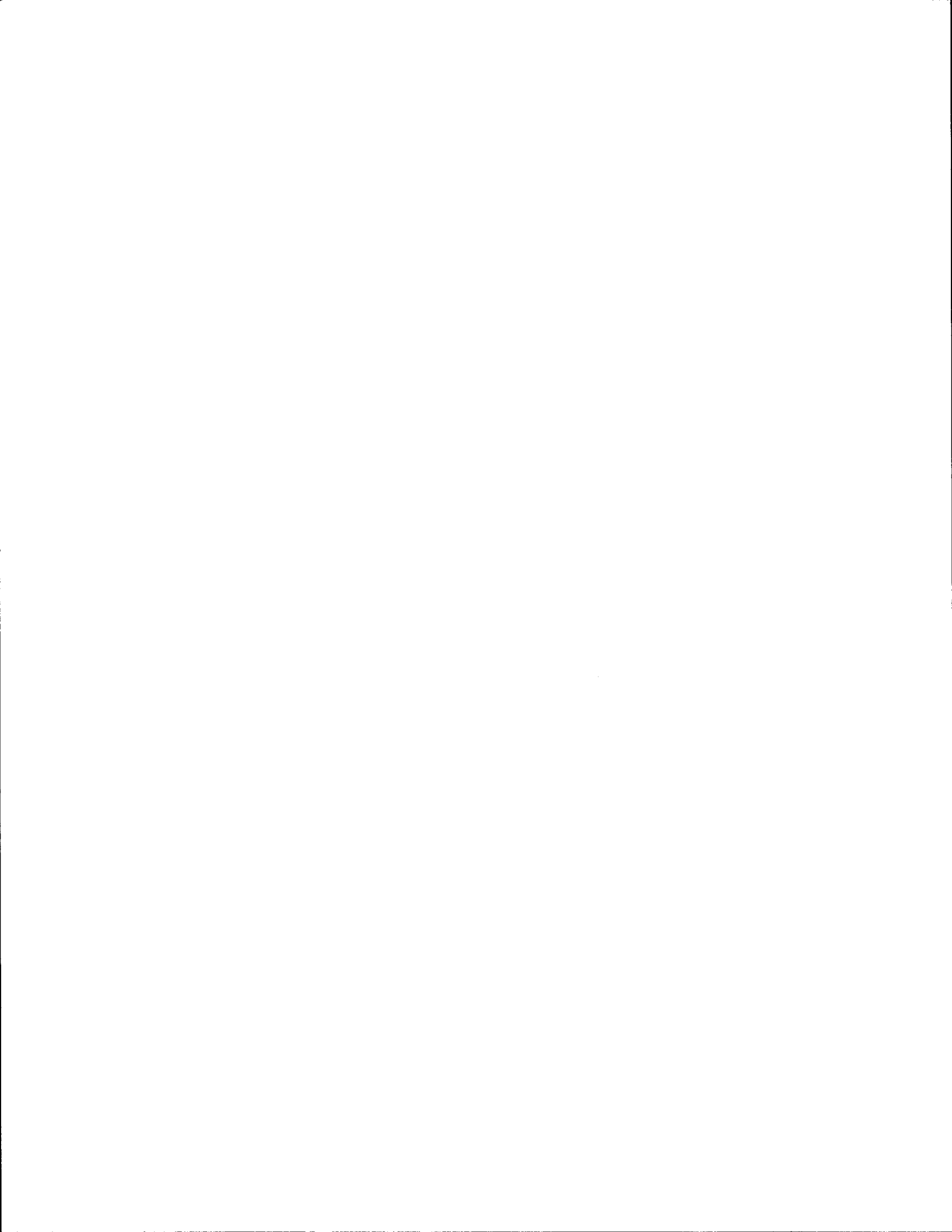



## TABLE OF CONTENTS

LIST OF FIGURES .....	x
LIST OF TABLES .....	x
SUMMARY .....	xi
INTRODUCTION .....	1
LITERATURE AND MANUAL REVIEW SUMMARY .....	3
FIELD PROBLEMS SURVEY SUMMARY .....	25
GROUP 1 PROBLEMS:.....	25
GROUP 2 PROBLEMS:.....	26
DESIGN RESOURCES .....	27
EROSION AND SEDIMENT CONTROL RESEARCH AGENDA .....	29
REFERENCES .....	31
APPENDIX A .....	39
APPENDIX B .....	49
APPENDIX C .....	57
APPENDIX D .....	61

## LIST OF FIGURES

Figure 1. Nomograph for Estimating "K" Values .....	19
Figure 2. Problem Survey Results .....	25
Figure 3. Temporary Erosion Control Computer Program .....	27-28

## LIST OF TABLES

Table A. Erosion and Sediment Control Functions and Application Areas .....	6-7
Table B. Erosion Control Blanket Effectiveness on Sandy Loam Soil .....	10
Table C. Erosion Control Blanket Effectiveness on Clay Soil .....	11
Table D. Hydraulic Mulches Effectiveness on Sandy Loam Soil .....	12
Table E. Hydraulic Mulches Effectiveness on Clay Soil .....	13
Table F. VM Factors for Stabilization Practices .....	14-15
Table G. VM Factors for Diversion Practices .....	16
Table H. VM Factors for Detention/Sedimentation Practices .....	17
Table I. VM Factors for Detention/Filtration Practices .....	17
Table J. VM Factors for Flow Spreading/Energy Dissipation Practices .....	18
Table K. Soil Erodibility Guide .....	20
Table L. Soil Erodibility Yield by Class .....	21
Table M. Wind Erodibility Groups and Soil Erodibility Index .....	23

## SUMMARY

Land disturbing activities such as construction and maintenance operations within the highway rights-of-way are necessary to meet the demands for the traveling public and continuing movement of goods. Unfortunately, these activities are a major cause of erosion and resultant receiving waters pollution. If not treated promptly and adequately, erosion-related impacts can include habitat changes, increased erosion and sediment losses, and increased pollutant loads

Achieving the maximum environmental benefits of an entire project's lifetime (planning and design phase, construction, and maintenance) has become an important goal for the Texas Department of Transportation (TxDOT). With the implementation of the Environmental Protection Agency's (EPA), National Pollutant Discharge Elimination System (NPDES) permitting requirements in 1992, an increased awareness and pro-active stormwater management program has been developing in TxDOT. The Department has developed guides to inform practitioners about recommended vegetation establishment and construction of temporary erosion and sediment control practices within the agency. An advisory team was formed to provide education and guidance on an "as-needed" basis. These actions have positively impacted the Department; however, problems encountered in the field and on the design board warranted further efforts.

During the past twenty years, there has been a proliferation of erosion and sediment control products and methods developed by the erosion industry. Industry standards have not kept up with the rapid changes. Education, testing, and application vary widely from one region to another. To meet the stringent environmental requirements placed on agencies today designers need appropriate guidance on planning, designing, and selecting best management practices for construction (and maintenance) sites. This research study was initiated to develop design guidelines that would complement TxDOT's existing efforts and provide guidance for further erosion and sediment control research.

Researchers evaluated the difficulties experienced during the design and selection process and provided guidance on several issues. Temporary erosion and sediment control planning is defined by the development of functional and application areas. A working glossary of terms has been created for cross-referencing other existing erosion manuals. Researcher developed strategies for selecting measures by understanding basic erosion principles. Researcher consolidate erosion predication factors VM (vegetative measures) and K (soil erodibility), from actual research data generate at the TxDOT/TTI Hydraulics and Erosion Control Laboratory as well as estimated values from existing literature. The most comprehensive tool developed is a PC-based computer program that helps the designer to select the appropriate best management practice, as recommended by TxDOT, and has report generation capability for the stormwater pollution prevention plans (SW3P).

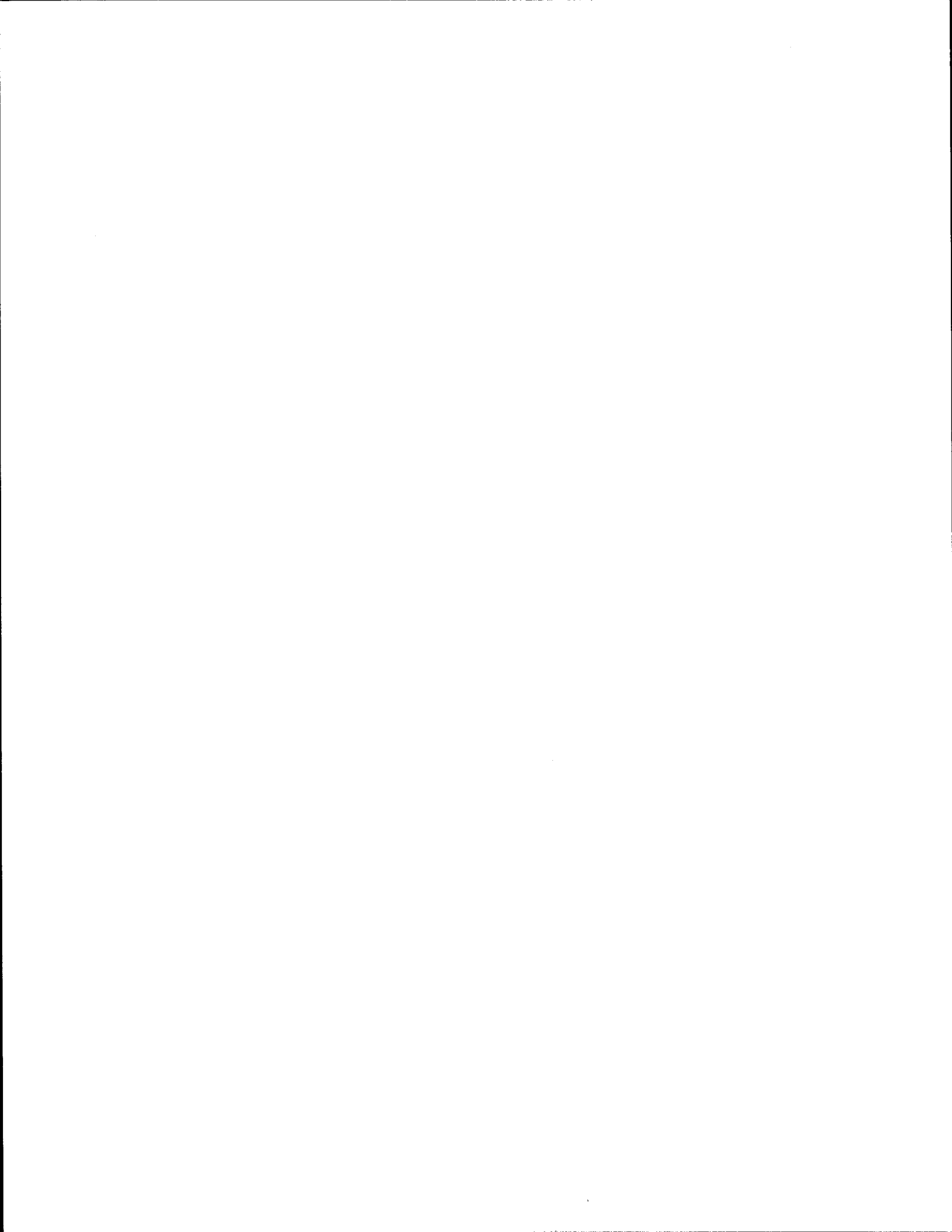

## INTRODUCTION

Erosion is the process by which the land surface is worn away by water, wind, ice, or other geological occurrences including gravitational creep. Natural erosion has been happening at a slow pace since the earth was formed and is a great factor in shaping the environment we know today. Several types of water erosion occur more rapidly such as accelerated, gully, rill, sheet, and splash erosion and are as follows:

- Accelerated erosion - Erosion that is more rapid than normal or natural and is usually a result of man's activities.
- Gully erosion - A form of water erosion created from a concentration of runoff that cuts the land into a narrow channel or miniature valley. Gullies usually begin as small rill formations.
- Rill erosion - An erosion process where many small shallow channels are formed. Rills typically occur on recently disturbed and exposed soils.
- Sheet erosion - Sheet erosion occurs from a fairly uniform, thin layer of surface runoff that detaches and removes soil in a uniform cut.
- Splash erosion - The displacement of small particles of soil caused by rainfall's initial impact.

Land disturbing activities such as construction and maintenance operations within the highway rights-of-way are necessary to meet the demands for the traveling public and continuing movement of goods. Unfortunately, construction-related activities are a major cause of water pollution. Accelerated erosion that increases the sediment load in runoff ultimately affects water quality in receiving waters during the construction process. Routine maintenance activities can cause rill formations that often turn into gullies. Without proper erosion and sediment controls, construction and maintenance operations, in the urban and rural corridor networks, have extensive environmental consequences. Erosion-related impacts can include habitat changes, increased erosion and sediment losses, and increased pollutant loads.

Achieving the maximum environmental benefits has become an important goal for today's highway engineers besides planning, designing, constructing, and maintaining a safe and cost-efficient system. The Texas Department of Transportation (TxDOT) has realized the opportunities for reaching these goals through their commitment to a comprehensive stormwater management program. In response to the National Environmental Policy Act of 1969 (NEPA) and the Clean Water Act, more attention has been focused on erosion and sediment control. For construction-related activities, the permitting requirements of the National Pollutant Discharge Elimination System (NPDES) of 1992 prompted transportation agencies increased concern for selecting, specifying, constructing, and maintaining erosion and sediment controls during the construction process.

Over the last twenty years there has been a rapid proliferation of erosion and sediment control materials and techniques for temporary, temporary/permanent, and permanent site controls that include the following products: erosion-control blankets and mats, turf reinforcement mats, hydraulic mulches, channel lining materials, silt dams and filters, bio-engineering techniques, and chemical soil stabilizers. Temporary erosion and sediment control measures are those products or methods used to stabilize soil and control sediment loss for short durations (< one year). These methods are typically used during highway construction projects. Temporary/permanent erosion and sediment control measures may be applicable for temporary or permanent erosion and sediment control depending upon the specific application and method of application. Permanent erosion and sediment controls, generally implemented to remain beyond the construction period, are divided into two categories: non-structural (vegetative) and structural. Non-structural permanent controls are those methods used to temporarily protect the seed bed until the perennial vegetation becomes established. Structural controls are constructed during the project when vegetative controls are not possible or to provide sediment control beyond the construction period.

The economical and environmental impact of erosion and sediment control measures used during the construction and maintenance activities of the Department is significant. A research study was begun to meet the designer's needs in selecting the appropriate erosion and sediment controls for construction projects that would complement the Department's existing efforts. TxDOT's pro-active efforts include the generation of the construction guide entitled, *TxDOT Storm Water Management Guidelines for Construction Activities*, 1993 and the development of a Stormwater Advisory Team (SWAT). The strengths of the guide included the descriptions of various *temporary* erosion and sediment controls as recommended by TxDOT. The SWAT team consisted of a group of individuals from different divisions within the department. They traveled and met with each district to review and provide help with problems and successes of controlling erosion and sediment on current construction sites. To fulfill the designer's needs for erosion and sediment control, two primary research objectives were developed as follows:

- To develop an erosion control research agenda that reflects the long-range needs of the TxDOT districts. The research priority agenda would include the needs for evaluating various erosion control technologies over the next five years.
- To prepare appropriate guidelines for the selection and application of erosion and sediment control measures.

To meet the research objectives, the research team conducted the following tasks: reviewed literature and manuals to assess the current available information on a national and state basis, conducted field interviews with selected districts to understand problems encountered, and developed design resources that would complement current department efforts. The purpose of this report is to document the research results and provide guidance to designers faced with controlling erosion and sediment during the construction process.

## LITERATURE AND MANUAL REVIEW SUMMARY

The research team reviewed literature on erosion control technology that dated from the 1930s Soil Conservation Service work to more recent manuals developed by governmental entities or agencies such as the *Puget Sound Manual* by the Department of Ecology for the State of Washington. Generally, the manuals provided good construction references for details and descriptions of erosion and sediment controls tailored for a specific region. Depending upon the focus of the guides (field construction guides or total project guides that include process guidelines from planning, design, construction, and maintenance), the level of detail varied. The comprehensive documents included technical information and detailed descriptions of the following: erosion processes, principles, laws and regulations, policy, erosion prediction, plan preparation, environmentally sensitive erosion techniques, and coordination issues.

The most common characteristics of these guides included the following observations: the selection recommendations seemed to rely upon local materials and their associated erosion and/or sediment control properties, the use of "regional" terminology, generous *VM* (vegetative and/or mechanical measure) factors for erosion estimation, and minimal maintenance information. When the selection process was weighted on the material's inherent erosion and sediment control traits, it was easy to overlook the basic issue of *what* is the function being performed and *how* does the designer select the appropriate measure. This information was not clear for the researchers.

From the research team's experience, the lack of a standard nomenclature could become a major disadvantage for a designer. Designers faced with the selection and plan preparation process for erosion and sediment control need a method for selecting the best management practice regardless if it is for temporary or permanent controls. Since designers often rely upon their own experiences and "library" of erosion-related books, articles, and product information, the variation in terminology and use of materials is confusing. For example, when the selection process is oriented to the material rather than its function, recommended measures (and materials) used in southwest Texas would not necessarily be the most economical materials for northeast Texas. To reduce water velocity in open channels, the current TxDOT guide recommends rock filter dams. Availability of rock in west Texas is not a problem, but for portions of east Texas it is a costly choice.

Using this example, rock filter dams, constructed of rock, stone, brush, hay, sand bags, and straw bales are referenced in other guides for use as a flow reducer and *filtering* measure (for sediment-laden flows). (The designer should select the appropriate material once the drainage area is figured and longevity of service is estimated.) Often it is not obvious to the TxDOT designer, that the function of a rock filter dam is twofold and may be accomplished with several different materials. Barriers and check dams made of locally available materials

should be selected so that the method meets the function required and is the most economical material to use.

Standard nomenclature has not been established by the erosion control industry but it is working to do so. The International Erosion Control Association (IECA) has a committee focused on the development of a standard nomenclature. Progress has been slow over the last two years and a completion date has not been set. The proliferation of erosion and sediment control products in recent years and published stormwater manuals directed toward meeting the NPDES requirements have not aided the committee's cause. Regional differences and industry marketing strategists do not seem to easily adopt current standardization efforts. In response to TxDOT's immediate needs, the research team developed a "working" glossary of definitions that includes terminology from the literature review (Appendix A). This glossary is a working document that will evolve as the industry becomes standardized. Other additions to be included will be from information exchanged on a national basis and new product research results.

The researchers felt that it was best to use the TxDOT terms as a basis for the glossary because of the existing work completed by the Environmental Affairs Division, Stormwater Advisory Task Force, and Northcutt's, *A Practical Guide to the Establishment of Vegetative Cover*. The TxDOT terms are listed along with synonymous terms, a brief description of the word, and a listing of common materials used to construct the measure. This approach attempts to accomplish the following: be a quick design reference that may be used with any existing stormwater manual, broaden the material selection from the TxDOT manual, and stress the functional aspect of the measure rather than its construction or material type.

TxDOT has given designers a goal of reducing sediment from disturbed areas by 70-80% (Godfrey, et al, 1993) through the use of erosion and sediment controls. This goal is an attainable one provided that the designer can predict and prevent erosion and sediment with effective controls. Specific erosion and sediment control objectives established by TxDOT that should be accomplished during the construction process include: preventing degradation of receiving waters, facilitating project construction and minimizing costs, and complying with Federal, State, and local regulations.

Planning and design decisions directly affect the success of preventing stormwater pollution, minimizing costs, and complying with applicable laws and regulations. Construction (and some maintenance) activities are land disturbing activities that counteract the stability of existing vegetated land. Minimal land disturbance is the key to "temporary" erosion control and is difficult to accomplish when constructing and maintaining large scale projects. Planning becomes a series of conflicting activities for the designer to juggle. Trying to balance and sequence activities to reduce disturbance is difficult to visualize and often cannot be developed into an absolute plan. A stormwater management plan should be interpreted as a working document used in the field as a conceptual guide.



When preparing Storm Water Pollution Prevention Plans (SW3P), the goals of the designer should be to minimize disturbance or limit it to a controllable level, buffer zones of activity from non-activity, and prevent erosion from occurring by non-structural or vegetative practices. The type of practice depends upon the duration of exposure. When it is not possible to prevent erosion, sediment controls will be necessary. From these goals, the researchers classified five functional areas of stormwater management that should be delineated on an SW3P for each significant construction phase. The five functional areas include the following:

- Stabilization - those measures placed to resist forces tending to cause erosion.
- Diversion - those measures placed to divert or intercept runoff and direct in a different course.
- Detention/Sedimentation - those measures placed to detain sediment-laden water or cause sediment to deposit from stormwater runoff.
- Detention/Filtration - those measures placed to intercept and reduce sediment-laden stormwater runoff, retain the sediment and release the water in sheet flow.
- Flow Spreading/Energy Dissipation - those measures placed to protect the (earth) surface from concentrated flows by reducing velocity and diffusing the flow into a sheet flow.

From these five functions that are achieved by erosion and sediment controls, the researchers defined application areas or control points that are common to construction project sites. The six primary application areas include the following:

- Slopes (flat, moderate, and steep),
- Channels,
- Site perimeter,
- Stream crossings,
- Construction roads, and
- Inlets.

The following tables show the erosion or sediment control functions and associated application areas. The erosion and sediment controls listed are referenced to the terminology used in the *TxDOT Stormwater Management Guidelines*. Specific information concerning the recommended design guidelines and details are shown in the existing TxDOT publication. The research team did not include other controls in these tables. As more practices, products, and methods are approved as best management practices by TxDOT, these recommendations may be added. The purpose of these tables is to coordinate the design process with the construction process that exists within the TxDOT structure.

Table A. Erosion and Sediment Control Functions and Application Areas

Function	Application Area					
	Slope	Channel	Perimeter Control	Stream Crossing	Road	Inlets
<b>Stabilization</b>						
Temporary Seeding	X		X			
Mulching	X					
Soil Retention Blankets	X					
Preservation of Natural Vegetation	X		X			
Buffer Zones (Vegetation)	X		X			
Transplanting Natural Vegetation	X					
Permanent Seeding/Sodding & Planting	X	X	X			
Surface Roughening	X					
Stabilized Construction Exit			X		X	
<b>Diversion</b>						
Diversion Dike	X		X			
Interceptor Dike	X		X			
Perimeter Dike	X		X			
Interceptor Swale			X			
Perimeter Swale			X			
Pipe Slope Drain	X					
Hay Bale Dikes	X					
Sediment Control Fence (Silt Fence)	X	X	X			X

Table A - continued.

Function	Application Area					
	Slope	Channel	Perimeter Control	Stream Crossing	Road	Inlets
<b>Flow Spreading/Energy Dissipating</b>						
Sediment Control Fence (Silt Fence)	X	X	X			X
Brush Berm	X	X	X			
Rock Filter Dam	X	X	X			X
Sand Bag Berm		X		X		
Stone Outlet Structure		X	X			
Function						
<b>Detention/Sedimentation</b>						
Hay Bale Dike	X					
Sand Bag Berm		X		X		
Sediment Trap		X	X			X
Sediment Basin		X	X			
Sediment Control Fence (Silt Fence)	X	X	X			X
Rock Filter Dam	X	X	X			X
Brush Berm	X	X	X			
<b>Detention/Filtration</b>						
Triangular Filter Dike	X		X			
Brush Berm	X	X	X			X
Sediment Control Fence (Silt Fence)	X	X	X			X
Stone Outlet Structure		X	X			
Rock Filter Dams	X	X	X			X

An effective and cost-efficient erosion and sediment control plan includes taking advantage of the basic principles that apply for most large scale projects. The research team interpreted the basic principles to generally include the following:

1. Plan the highway project to minimize topography and drainage pattern changes, keep existing vegetation and avoid highly erodible soils, as practical. Prevention of erosion is much more cost effective than sediment capture later.
2. Conduct a site drainage analysis to study where stormwater runoff will enter, cross, and exit the site. Plan for isolating disturbed areas within the construction site from surrounding properties by placing perimeter controls, when possible, that will prevent excessive sediment damage. Measures that will retain sediment within the construction site include controls that perform either detention/sedimentation or detention/filtration functions.
3. Provide guidelines that would limit and phase clearing or establish minimum areas of disturbed surface area to be included in the contract documents. Restrict construction traffic to those locations and place controls that will reduce the tracking of sediment off-site to provide additional benefits.
4. Plan to revegetate disturbed (graded) areas as they are completed with the appropriate vegetative practices. A vegetative cover is the most effective erosion control. As a minimum, the areas should receive a mulch application to provide the optimum growing conditions attainable for a construction site. Depending upon the steepness of slope and soil type, additional requirements for successful revegetation include erosion-control blankets (soil retention blankets).
5. Keep stormwater runoff velocities low. The result of removing existing surface cover and increasing impermeable surface area during construction increases both the volume and velocity of runoff. The designer must include these considerations when selecting the appropriate erosion or sediment control measures. Minimize slope length and steepness. Convey construction site runoff in stabilized outlets designed for peak discharge velocities.
6. Plan for maintenance and routine follow-up to check effectiveness. Select measures that meet the maintenance levels achievable and desirable for the duration of the project. Regular maintenance checks are essential to ensure that the controls are working properly. The designers should receive feedback from the construction project engineer to evaluate and observe the most efficient and maintenance-free controls for future projects.

A stormwater pollution prevention plan developed with these principles should result in fewer problems with soil erosion, uncontrolled runoff, and excessive sedimentation during the

construction process. The designer should understand the functions, application areas, and basic erosion control principles involved to successfully develop a stormwater pollution prevention plan. Besides these concepts, predicting soil erosion loss on construction sites is a critical factor in selecting the best management practice.

During the construction process, the site will be subjected to natural forces of erosion from rainfall, stormwater runoff, and wind. There are also many man-made causes of erosion such as clearing, grubbing, and grading activities. These losses are not always apparent to the construction supervisors since shallow sheet flow from runoff can potentially cause more sediment loss than concentrated flows during an intense storm. Construction sites are vulnerable to repeated losses during their exposure to the natural elements if not properly protected. Selecting and constructing the most appropriate measures depend, in part, on the designer's selection of erosion and sediment control measures that are capable of withstanding the magnitude of erosive forces.

As recommended by the Texas Department of Transportation, the Modified Universal Soil Loss Equation (MUSLE) (Israelson, 1980) can be used as a tool to estimate erosion from construction sites. The MUSLE equation is as follows:

$$A=R \times K \times L \times S \times V M$$

where:

A = rate of soil loss in tons per acre per year

R = rainfall erosion factor

K = soil erodibility factor

LS = length/slope factor

VM = erosion control factor (non-structural and structural measures)

The researchers evaluated each factor involved for using the MUSLE to search for variation that would cause the designers problems in predicting erosion. Two factors, "R" and "LS," are straightforward as provided by the existing *TxDOT Guide*. Appendix B shows the reproduction of these factors, for reference only. The researchers did feel that the "K" factor and the "VM" factor were two elements that should be addressed in further detail.

It is recognized that the MUSLE is an adequate prediction tool with limitations. The accuracy of predicting soil losses depends upon effectiveness factors for non-structural (vegetative) and structural measures that are not always proven or known values. Limited data exist for the effectiveness of available erosion and sediment controls under various conditions and combinations of soil, slope steepness and length, and rainfall and runoff severity. Usually, these values have been generalized down to one number that is supposed to meet all of the conditions. This is an unlikely probability.

Rather than assume that the VM factor is a constant, as described by Clyde et al. (1976), the research team developed VM value tables that reflect the variability of each measure depending

upon the soil and expected service life. These values are derived from the current level of knowledge on various measures. In other words, they are not all proven values. For non-structural practices, investigative work accomplished by Armstrong and Wall (1991) demonstrated the differences in performance for erosion-control blankets and mulches when subjected to an erosive force (simulated rainfall). Their field trials demonstrated that erosion-control blanket and mulch effectiveness decreases when subjected to erosive forces. They also showed that a mulch's effectiveness decreased at a faster rate than an erosion-control blanket when each was subjected to a simulated rainfall. Therefore, the VM factor for each of these measures was a variable value and not a constant one.

Table B. Erosion Control Blanket Effectiveness on Sandy Loam Soil

<b>Erosion-Control Blanket Effectiveness (VM) Factor</b>		
Generic Classification	VM Factor 90+ days Average	% Effectiveness vs. Control*
Excelsior Blankets	0.06	94
Straw/Coconut Blankets	0.09	91
Straw Blankets	0.09	91
Polypropylene/Cotton Blanket	0.13	87
PVC	0.15	85
Gypsum & Mulch "Blanket"	0.41	59

\*Control: Sandy Loam Soil (K=0.38), all treatments were seeded with permanent seed mixture.

Table C. Erosion Control Blanket Effectiveness on Clay Soil

<b>Erosion-Control Blanket Effectiveness (VM)</b>		
<b>Factor</b>		
Generic Classification	VM Factor 90+ days Average	% Effectiveness vs. Control*
Coir Fabric	0.05	95
Straw/Coconut Blankets	0.07	93
Jute Netting	0.08	92
Polypropylene/Cotton Blanket	0.08	92
Excelsior Blankets	0.09	91
Straw Blankets	0.09	91
PVC	0.10	90
Gypsum & Mulch "Blanket"	0.35	65

\*Control used was Clay Soil ( $K=0.20$ ), all treatments were seeded with permanent seed mixture.

Establishing a range of values for non-structural practices such as hydromulches was difficult to accomplish. Several references have noted hydraulic mulches to have an effectiveness index or VM factor between (0.10 and 0.01) which is a 90-99% effectiveness rating. However from field trial observations at the TxDOT/TTI Hydraulics and Erosion Control (HEC) Laboratory, mulches have shown significantly lower effectiveness values. When hydraulic mulches are placed on a steep gradient and subjected to normal rainfall distribution throughout the growing season, they have averaged 55% vegetative coverage in one growing season. Erosion-control blankets (soil retention blankets) placed under the same conditions have yielded an average of 87% vegetative coverage (Godfrey, et. al, 1993).

Investigative erosion control trials conducted at the HEC laboratory during 1993 showed the VM factor ranged between 0.05 - 0.33 for mulches. Each treatment plot was replicated on an erosive (sandy loam) soil and an erosion resistant (clay) soil and subjected to a series of 1-year design storms during the summer. No vegetation was seeded. On the erosive (sandy) soil, the mulches performed better than on the erosion resistant (clay) soil when compared to the controls. Results of these findings are shown in Tables D and E. When comparing these results to the vegetation establishment findings, it appears there must be a logical breakpoint in the mulches capability to withstand the erosive forces of natural rainfall during the first growing season. Once this point is surpassed the soil's susceptibility to erosion is diminished and the resultant vegetation density measurements achieved are lower.

Table D. Hydraulic Mulches Effectiveness on Sandy Loam Soil

<b>Hydraulic Mulches Effectiveness (VM) Factor</b>		
<b>Generic Classification</b>	<b>VM Factor 1-yr design storm Average</b>	<b>% Effectiveness vs. Control*</b>
Recycled Natural Fibers/Paper	0.03	97
Wood fiber	0.05	95
Straw with tackifier	0.06	94
Tackifier only	0.08	92
Hay with tackifier	0.09	91

\*Control used was Sandy loam Soil (K=0.38), no seeding was applied.



Table E. Hydraulic Mulches Effectiveness on Clay Soil

<b>Hydraulic Mulches Effectiveness (VM) Factor</b>		
Generic Classification	VM Factor 1-yr design storm Average	% Effectiveness vs. Control*
Recycled Natural Fibers/Paper	0.13	87
Wood fiber	0.22	78
Straw with tackifier	0.23	77
Hay with tackifier	0.33	67
Tackifier only	0.39	61

\*Control used was Clay Soil ( $K=0.20$ ), no seeding was applied.

The data generated by all of this research suggest that there are differences in performance of non-structural practices. Collecting data on the breakdown points in recommended measures for various application areas is necessary for further interpretation or estimation of VM factors. A better understanding of the relationship between the environmental factors influences on material performance is critical to accurately predict temporary erosion control measures effectiveness.

The following tables are provided to aid the designer in selecting the most appropriate VM factor based upon the function and application area, soil type (cohesive or non-cohesive), and expected service life rating. These tables should be updated as more information is made available.

Table F. VM Factors for Stabilization Practices

Stabilization Practices	VM Value	Expected Service Life				
		0-30	30-60	60-90	90-18	180+
<b>Preservation</b>	N/A	H	H	H	H	H
<b>Grading Management</b>						
Surface Roughening	0.9	L	-	-	-	-
Freshly disced, after one (1) light rain	0.89	L	-	-	-	-
Bare soil, unprotected, loose as disced by plow	1.00	L	-	-	-	-
<b>Compact &amp; smooth</b>						
Scraped up and down slope by bulldozer	1.30	L	-	-	-	-
Scraped across slope by bulldozer	1.30	L	-	-	-	-
Compacted fill, type 1 & 2 slope	0.60	L	-	-	-	-
Scraped soil, type 1 & 2 slope	1.30	L	-	-	-	-
Scraped soil, type 3 & 4 slope	0.61	L	-	-	-	-
Scarified only	.76-1.31	L	-	-	-	-
<b>Temporary Seeding</b>						
Small grain, type 1 & 2 slope, (90 % cover)	0.05	L	L	L-M	H	H-M
Millet grain, type 1 & 2 slope, (90 % cover)	0.05	L	L	L-M	H	H-M
Field Bromegrass, type 1 & 2 slope, (90 % cover)	0.03	L	L	L-M	H	H-M
<b>Temporary Seeding with Mulch (1 ton/acre), then permanent seeding</b>						
0-3 months	1.20	L	L	L	-	-
3-6 months	0.13	-	-	-	M	
6-18 months	0.05	-	-	-	-	H
<b>Permanent seeding, type 1&amp;2 slope (90% cover)</b>	0.01	L	L	L	M	M
<b>Sod (laid block solid)</b>	0.01	M	M	H	H	H
<b>Temporary Seeding with Mulch [2.24 kg/ha (1 ton/acre)]</b>	0.13	L	L	L	M	M
<b>Mulching</b>						
Hay [3.36 kg/ha (1.5 tons/acre)]	0.25	M	M	M-L	-	-
Hay [4.49 kg/ha (2.0 tons/acre)]	0.02	H	H-M	M-L	-	-
Small grain straw [4.49 kg/ha (2 tons/acre)]	0.02	H	H-M	M-L	-	-

Table F - continued.

Stabilization Practices	VM Value	Expected Service Life				
		0-30	30-60	60-90	90-18	180+
Wood chips [13.45 kg/ha (6 tons/acre)]	0.06	H	H-M	M-L	-	-
Wood cellulose [6.87 kg/ha (1.75 tons/acre)]	0.10	H	M	L	L	-
Recycled paper/natural fibers						
Type 3 slope, noncohesive soil	0.03	H	H-M	M-L	L	-
Type 3 slope, cohesive soil	0.13	M	M	M-L	L	-
Wood fiber mulch [2.80 kg/ha (1.25 tons/acre)]						
Type 3 slope, noncohesive soil	0.06	H	H-M	M-L	L	-
Type 3 slope, cohesive soil	0.23	M	L	L	L	-
Straw with tackifier [6.87 kg/ha (1.75 tons/acre)]						
Type 3 slope, noncohesive soil	0.06	H	H-M	M-L	L	-
Type 3 slope, cohesive soil	0.23	M	L	L	L	-
Hay with tackifier [6.87 kg/ha (1.75 tons/acre)]						
Type 3 slope, noncohesive soil	0.09	H	H-M	M-L	-	-
Type 3 slope, cohesive soil	0.33	L	L	L	-	-
Tackifier only, type 3 slope	0.66	L	-	-	-	-
Asphalt emulsion [812 L/ha (1250 gal/acre)]	0.02	H	M	L	-	-
Fiberglass mulch [3.36 kg ha (1.5 tons/acre)]	0.05	H	M	L	-	-
<b>Soil Retention Blankets (Erosion-Control Blankets)</b>						
Excelsior Blanket						
Type 3 slope, noncohesive soil	.06-.15	M-H	M-H	M-H	M-H	M-H
Type 3 slope, cohesive soil	.05-.10	H	H	H	H	H
Gypsum & Mulch "Blanket"						
Type 3 slope, noncohesive soil	0.14	L	L	L	L	L
Type 3 slope, cohesive soil	0.35	L	L	L	L	L
Fiberglass roving, 227 - 567 L (60-150 gal.) asphalt emulsion Type 1 & 2 Slope	.01-.05	H	H	M-H	M	-
Soil Retention Blanket with Temp Seeding	N/A	M-H	M-H	M-H	M	M-L
Dust Binder						
5 717 L/ha (605 gal/acre)	1.05	L	-	-	-	-
11 243 L/ha (1210 gal/acre)	.29-.78	L	-	-	-	-
Buffer Zone	N/A	H	H	H	H	H

Table G. VM Factors for Diversion Practices

<b>Diversion Practices</b>	VM Value	Expected Service Life				
		0-30	30-60	60-90	90-18	180+
<b>Dike (Diversion, Interceptor, or Perimeter)</b>						
Brush	0.35	L	L	L	-	-
Compacted Earth	N/A	L	L	-	-	-
Gravel/Rock	N/A	L	L	L	L	L
Hay/Straw	N/A	L	L	-	-	-
Sand Bags	0.30	L	L	-	-	-
<b>Swale (Interceptor or Perimeter)</b>						
With Stabilization Practices	0.30	L	L	L-M	M	M
Without Stabilization Practices	N/A	L	L	L	-	-
<b>Pipe Slope Drain</b>						
Type 3 or 4 Slope	N/A	L	L	L	L	L
<b>Sediment Control Fence (Silt Fence)</b>						
Biodegradable with routine Maintenance	N/A	L	L	L	L	-
Synthetic with routine Maintenance	N/A	L	L	L	L	L
Without Maintenance	N/A	L	L	L	-	-

Table H. VM Factors for Detention/Sedimentation Practices

<b>Detention/Sedimentation</b>	VM Value	Expected Service Life				
		0-30	30-60	60-90	90-18	180+
<b>Hay Bale Dike with maintenance</b>	N/A	L	L	-	-	-
<b>Hay Bale Dike without maintenance</b>	N/A	L	-	-	-	-
<b>Rock Filter Dam with maintenance</b>	N/A	L	L	L	L	L
<b>Sediment Control Fence (Silt Fence), with maintenance</b>	N/A	L	L	L	L	L
<b>Berm</b>						
Brush with maintenance	0.35	L	L	L	-	-
Sand Bag with maintenance	N/A	L	L	-	-	-
<b>Sediment Trap with maintenance</b>	N/A	L	L	L	L	L
<b>Sediment Trap with stabilization upstream &amp; maintenance</b>	N/A	L	L	L-M	M	M
<b>Sediment Basin with maintenance</b>	N/A	L	L	L	L	L

Table I. VM Factors for Detention/Filtration Practices

<b>Detention/Filtration</b>	VM Value	Expected Service Life				
		0-30	30-60	60-90	90-18	180+
<b>Triangular Filter Dike with maintenance</b>	N/A	L	L	L	-	-
<b>Rock Filter Dam with maintenance</b>	N/A	L	L	L	L	L
<b>Rock Filter Dam with stabilization upstream &amp; maintenance</b>	N/A	L	L	L-M	M	M
<b>Sediment Control Fence (Silt Fence), synthetic with maintenance</b>	N/A	L	L	L	L	L
<b>Berm</b>						
Brush	0.35	L	L	L	-	-
Brush with stabilization upstream	N/A	L	L	L-M	M	M
Sand Bag	N/A	L	L	-	-	-
Sand Bag with stabilization upstream	N/A	L	L	L-M	M	M
<b>Stone Outlet Structure with maintenance</b>	N/A	L	L	L	L	L
<b>Stone Outlet Structure with stabilization upstream</b>	N/A	L	L	L-M	M	M

Table J. VM Factors for Flow Spreading/Energy Dissipation Practices

Flow Spreading/Energy Dissipating	VM Value	Expected Service Life				
		0-30	30-60	60-90	90-18	180+
Sediment Control Fence (Silt Fence) with maintenance	N/A	L	L	L	L	L
<b>Berm</b>						
Brush	0.35	L	L	L	-	-
Brush with stabilization upstream	N/A	L	L	L-M	M	M
Rock with stabilization upstream	N/A	L	L	L-M	M	M
Sandbag with stabilization upstream	N/A	L	L	L-M	M	M
Compacted Earth with stabilization upstream	N/A	L	L	L-ML	M	M
<b>Stone Outlet Structure</b>	N/A	L	L	L	L	L

The soil erodibility factor, K, is a numeric representation of the soil's ability to resist the erosive forces of rainfall. A "K" value may be obtained from soil survey information or soil reports. As with the VM factors, a soil's erodibility factor may be altered by the disturbance from many construction activities. Various information exists on the importance or relevance of the soil erodibility factor in predicting erosion. In the study, *Highway Construction Site Erosion and Pollution Control Manual, 1990* (Horner et. al) the researchers developed a triangular nomograph for estimating K value. They used the soil texture triangle from the *National Soils Handbook*, Figure 603-1, and overlaid the K values. Adjustment tables were developed for factoring organic matter and rock content. The researchers noted that the adjustments for rock content were similar to that for organic matter, more rock (defined as the percent by volume of soil particles greater than 2 mm) in the soil yields less sediment. Figure 1 shows this triangle.

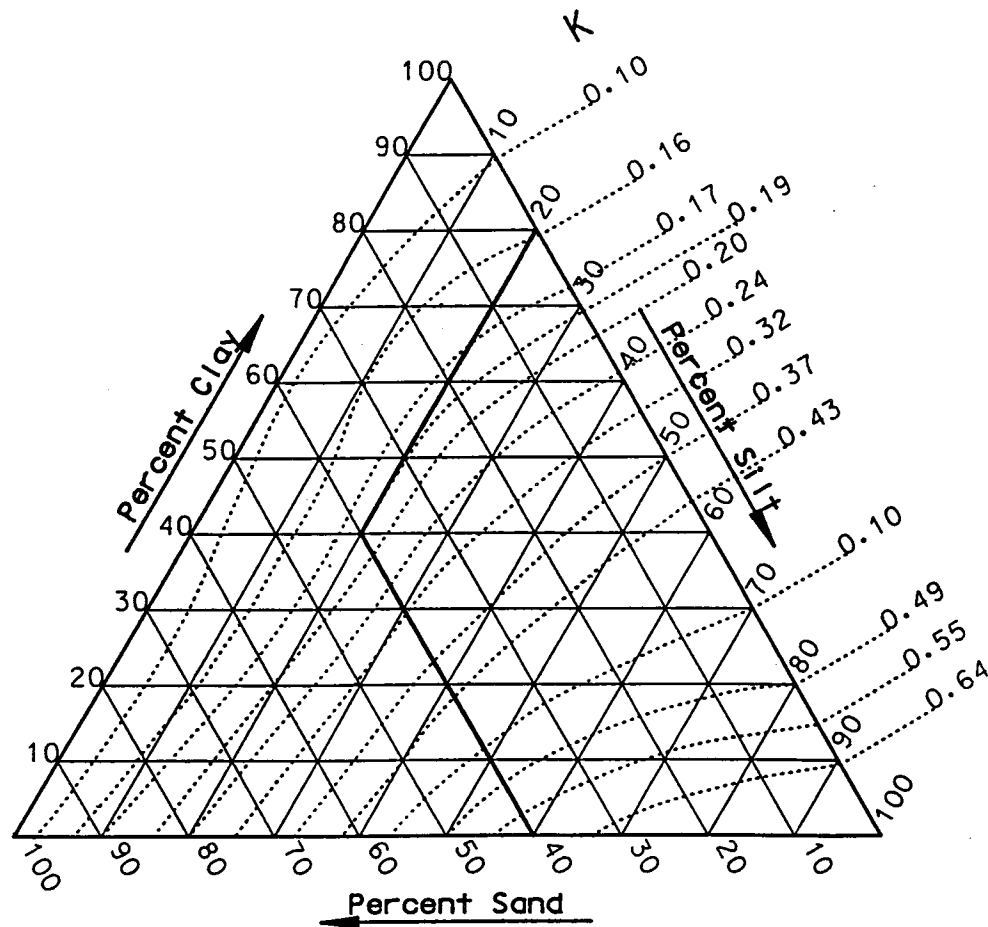

Figure 1. Nomograph for Estimating "K" Values

Much of Armstrong's and Wall's studies have shown the relationship between soil texture and erodibility, organic matter, and resultant sediment yield. Their studies have shown that K factors for topsoil and stockpiled topsoil are similar while the K factors for reconsolidated soil were higher due to yielding significantly greater quantities of sediment. Adjustments by the designer are necessary to compensate for the differences by raising the K factor up level when using reconsolidated soils.

The research team compiled this information into a tabular format as a tool for the designer to use. For the soil planned to be used as a growing medium (temporary or permanent seeding and planting), the K value is shown as a range that depends upon the amount of organic matter present. Since existing research data did not indicate similar categories for organic matter quantities, the researchers noted that the greater the amount of organic matter the less sediment was yielded. Table K shows the Soil Erodibility Guide.

Table K. Soil Erodibility Guide

<b>Soil Erodibility Guide</b>		
<b>Soil Texture</b>	<b>K value Range</b>	<b>Sediment Yield</b>
Sand	0.02 - 0.05	Low
Fine Sand	0.10 - 0.16	Low
Very Fine Sand	0.28 - 0.42*	Med. - High
Loamy Sand	0.08 - 0.12	Low
Loamy Fine Sand	0.16 - 0.24**	Low - Med.
Loamy Very Fine Sand	0.30 - 0.44*	Med. - High
Sandy Loam	0.19 - 0.27**	Low - Med.
Fine Sandy Loam	0.24 - 0.35	Medium
Very Fine Sandy Loam	0.33 - 0.47*	Med. - High
Loam	0.29 - 0.38	Medium
Silt Loam	0.33 - 0.48*	Med. - High
Silt	0.42 - 0.60	High
Sandy Clay Loam	0.21 - 0.27	Medium
Clay Loam	0.21 - 0.27	Medium
Silty Clay Loam	0.26 - 0.37	Medium
Sandy Clay	0.12 - 0.14	Low
Silty Clay	0.19 - 0.25**	Low - Med.
Clay	0.13 - 0.20**	Low - Med.

\* > 0.38 = High Yield    \*\* > 0.19 < 0.38 = Med. Yield



As it relates to a soil's "K" factor, several agencies have adopted the terminology *sandy* or *clay* that implies the soil's capability to resist the erosive forces of rainfall. The research team has used these terms similarly to coordinate with TxDOT's standard specifications. Interchanging these terms may simplify communication between designers, but they are not truly representative of a soil's susceptibility to erosion. All of the soil types consisting of clay have a low to medium sediment yield, but there are many soils classified as sandy that have a low to medium sediment yield as well. Generally, researchers and agencies have used the term "erosion-resistant" or "clay" soils when referring to these soils. Likewise, most of the soils with a medium to high sediment yield consist of sands and silts, but there are many clay soils with a medium sediment yield. Table L shows the soils listed by sediment yield to illustrate this point.

Table L. Soil Erodibility Yield by Class

Soil Erodibility Yield by Class		
Low Yield	Medium Yield	High Yield
Sand*	Very Fine Sand	Very Fine Sand
Fine Sand*	Loamy Fine Sand	Loamy Fine Sand
Loamy Sand*	Loamy Very Fine Sand	Loamy Very Fine Sand
Loamy Fine Sand	Sandy Loam	Very Fine Sandy Loam
Sandy Loam	Fine Sandy Loam*	Silt Loam
Sandy Clay*	Loam*	Silt*
Silty Clay	Silt Loam	
Clay	Sandy Clay Loam*	
	Clay Loam*	
	Silty Clay Loam*	
	Silty Clay	
	Clay	

\*Indicates the soil's erodibility rating is within one category as listed.

Predicting the soil erosion losses for each surface drainage area affected by the construction activities is an interactive process. Typical to the design process, a designer works through many scenarios before arriving at the most efficient and cost-effective design solution. This also applies to developing a thorough and well-planned stormwater pollution prevention plan. Changing first attempts at erosion control plans with more cost-efficient materials, subdividing the drainage areas into smaller units, sequencing construction activities differently, altering slope gradients and lengths, establishing vegetative cover quicker, and lowering maintenance demands are all examples of *where* to look for better solutions.

An obvious point that is usually overlooked is the need to consider wind erosion, especially for the western portion of Texas. The wind erosion equation was developed for use on agricultural lands but may be applied to construction sites for estimating soil erosion losses. Wind erosion may begin at a critical location such as an exposed highpoint and equipment paths. As the soil moves downwind, the number of soil particles increases and flow begins. The distance required to reach maximum flow is influenced by the soil's erodibility capability. The Soil Conservation Service's (SCS) wind erosion equation is as follows:

$$E = f(IKCLV)$$

where:

E = Potential average annual soil loss in kilograms (tons) per hectare (acre)

f = Function of

I = Soil erodibility index. It is expressed in kilograms (tons) of soil loss per hectare (acre) annually where the C value is 100%. The factor is determined by the percentage of dry, non-erodible soil aggregates greater than 0.84 mm in diameter.

K = Soil ridge roughness factor. Ridges and depressions formed by tillage alter windspeed by absorbing and deflecting part of the wind energy away from erodible soil. Rough surfaces also trap moving particles.

C = Climate factor. The general level of wind velocity, the quantity and frequency of rainfall, and the rate of drying of the soil surface differ from one region to another. The values in Texas range from about 5 % to 120% with the latter index indicating the most hazardous wind erosion conditions.

L = The unsheltered distance across a field or strip along the prevailing wind erosion direction. If a barrier is present on the windward side of the field, the distance protected by the barrier is subtracted from the total distance across the field along the prevailing direction. A distance equal to 10 times the effective height of the barrier is usually subtracted from the total distance along the prevailing wind when using the wind erosion equation to calculate the amount of soil loss.

V = The equivalent effects of vegetative cover or residue and includes the quantity of residue in pounds per acre and its orientation, such as standing or flat.

Along with this equation explanation, detailed examples of using the wind erosion equation are shown in the SCS's *Erosion and Sediment Control Guidelines for Developing Areas in Texas, 1976*. Table M was adapted from the SCS Guidelines, table 3-5, to highlight problem soils located in high wind areas of Texas. Suggested controls for non-structural (vegetative) practices are shown

to the right of the table as recommended by the research team. Limited information exists on cost-effective controls targeted at solving windy construction sites. However, the researchers see a need to explore erosion control solutions for those districts that do encounter wind erosion as a prevalent erosive force.

Table M. Wind Erodibility Groups and Soil Erodibility Index

WIND ERODIBILITY GROUPS (WEG) AND SOIL ERODIBILITY INDEX (I)		
Wind Erodibility Group	Definition and Predominant Soil Textural Classes	Wind Erodibility Index (I) kg/ha/yr (Tons/Ac/Yr)
1	All sands, coarse sands, fine sands, and very fine sands. (Extremely erosive; vegetation difficult to establish)	310
2	All loamy sands, loamy fine sands, and loamy very fine sands. (Very highly erosive)	134
3	All sandy loams, coarse sandy loams, fine sandy loams, and very fine sandy loams. (Highly erosive)	86
4L	All calcareous loamy soils with less than 35 percent clay and more than 5 percent finely divided calcium carbonate. (Erosive)	86
4	All clays and silty clays, and all clay loams, and silty clay loams with more than 35 percent clay. (Moderately erosive)	86
5	All loamy soils with less than 18 percent clay and less than 5 percent finely divided calcium carbonate, and all sandy clay loams and sandy clays with less than 5 percent finely divided calcium carbonate. (Slightly erosive)	56
6	All other loamy soils with 18 to 35 percent clay and less than 5 percent divided calcium carbonate, except silty clay loams. (Very slightly erosive)	48
7	All silty clay loams with less than 35 percent clay and less than 5 percent finely divided calcium carbonate. (Very slightly erosive)	38
8	All stoney or gravelly soils, or other soils not subject to soil blowing.	--

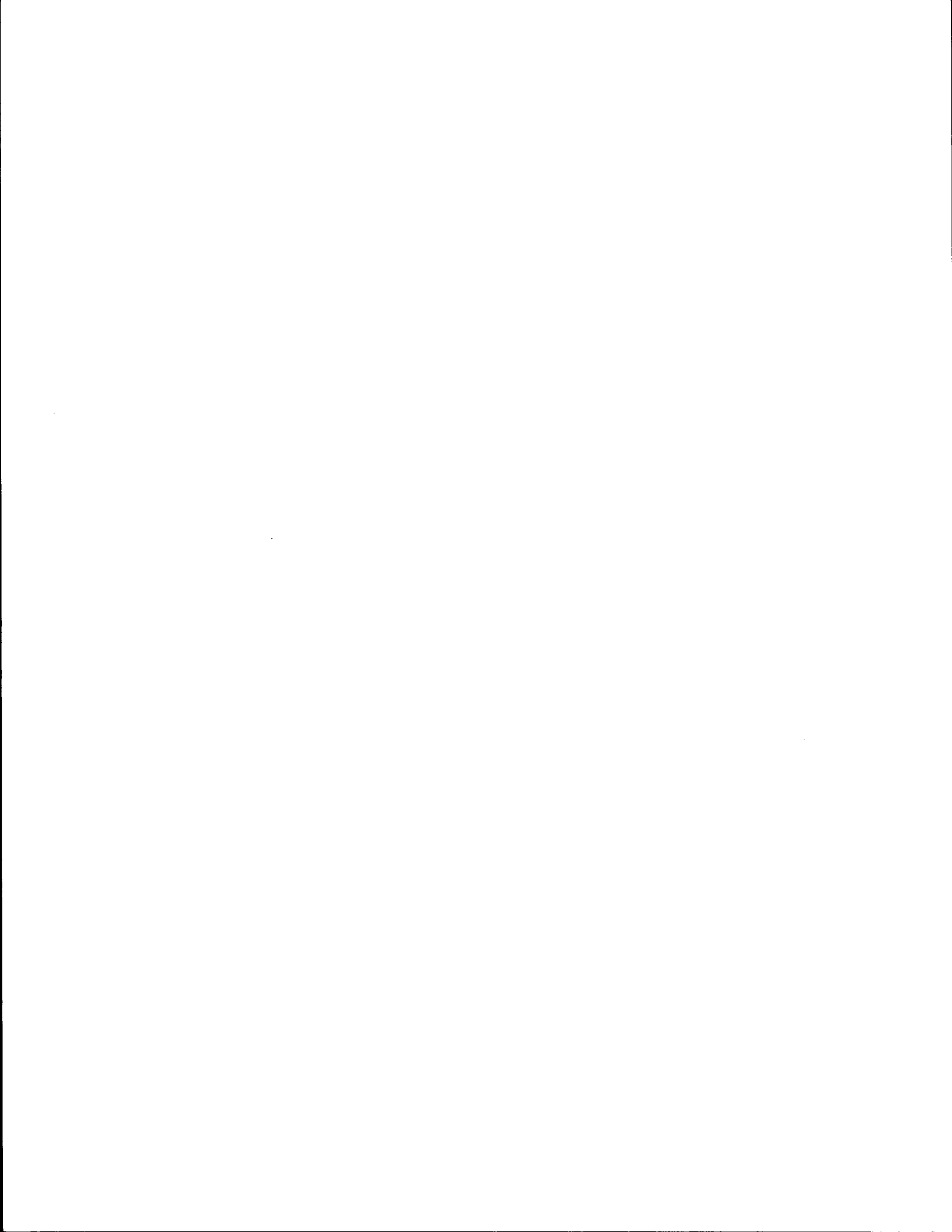

## FIELD PROBLEMS SURVEY SUMMARY

The research team visited representative districts around the state to find out what problems existed for the construction engineers and to assess the current temporary erosion and sediment controls being used. The researchers discovered a variety of problems encountered in the field. researchers grouped the problems into eleven problem areas and then categorized them as either major or minor in significance. The first four problems are the major problems that total approximately 80% of the difficulties. The remaining items, or 20% of the total problems, were considered to be minor problems that would work themselves out if the major problem areas were adequately addressed. Figure 2 shows the responses as a percentage of the total responses ranked according to their magnitude.

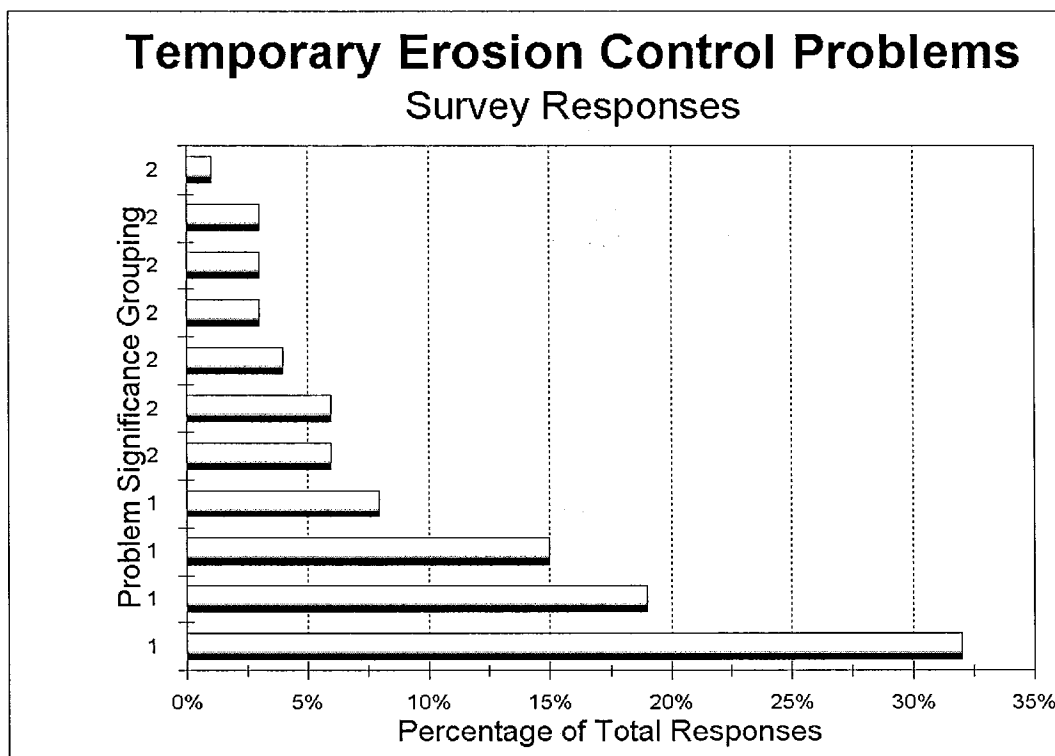

Figure 2. Problem Survey Results

### GROUP 1 PROBLEMS:

- Selection of measure was inadequate for the function required - 32%
- Seeding specification was not used correctly or misunderstood - 19%
- Under utilization of local materials - 15%
- Temporary erosion control measure was not maintained - 08%

## GROUP 2 PROBLEMS:

- Stream crossing protection was inadequate - 06%
- Did not alter slope steepness when possible - 06%
- Handling of waste materials was incorrect - 04%
- Construction exits were not properly stabilized - 03%
- Temporary erosion control measure was not implemented because area was flat - 03%
- Improper installation of measure - 03%
- Installation of material other than specified - 01%

The research team made recommendations for solutions during the spring meeting of this research project as follows. Continuing education will be the key to providing the designers and construction and maintenance engineers with a comprehensive view of how to manage stormwater for land disturbing activities such as construction or maintenance operations. The educational emphasis would cover the following issues: guidance of construction phasing techniques to reduce erosion, determining functions required during stormwater management for each significant construction phase, selection of measures from application charts and/or computer program, and providing sources of help during the project design and construction. The researchers encouraged the technical panel to consider continuing education that could be developed in a variety of communication modes. Deliverables such as 1-2 day courses on-site or at a central location, a video for distribution, a CD-rom interactive program, or a comprehensive or "intelligent" computer program would be beneficial in these efforts.

From the field survey, designers and engineers used the following temporary erosion and sediment control measures most often: sediment control fences, hay bale dikes, rock filter dams, temporary seeding (both with and without recommended seeding mixtures), earth windrows at the top of embankments, sand bags, roughened surfaces (both parallel and perpendicular to the slope), rock berms and sediment control fences, grading changes to flatten slopes, and gabions.

Most of the districts had achieved a satisfactory level of effort to comply with the NPDES requirements according to the findings provided by the Stormwater Advisory Team. The research team noted that there was not a wide range of temporary erosion and sediment controls being used and that sediment control fences were used extensively throughout the State.

## DESIGN RESOURCES

This document contains many design resources that should aid the designer in selecting erosion and sediment control measures. As a part of the research study, researchers developed a PC-based computer program for selecting Best Management Practices (BMP's). It was shown for review at the spring meeting. Generally, it processes information given by the designer to choose recommended temporary erosion and sediment controls as approved by TxDOT. Updates to the program will be necessary as more information is obtained. The diagram below (Figure 3) illustrates the sequence of information necessary to run the computer program. Once the data is entered, a report can be generated as output. This report, computer program, and TxDOT Stormwater Guide should be used together as a base for the decision-making process.

Figure 3. Temporary Erosion Control Computer Program

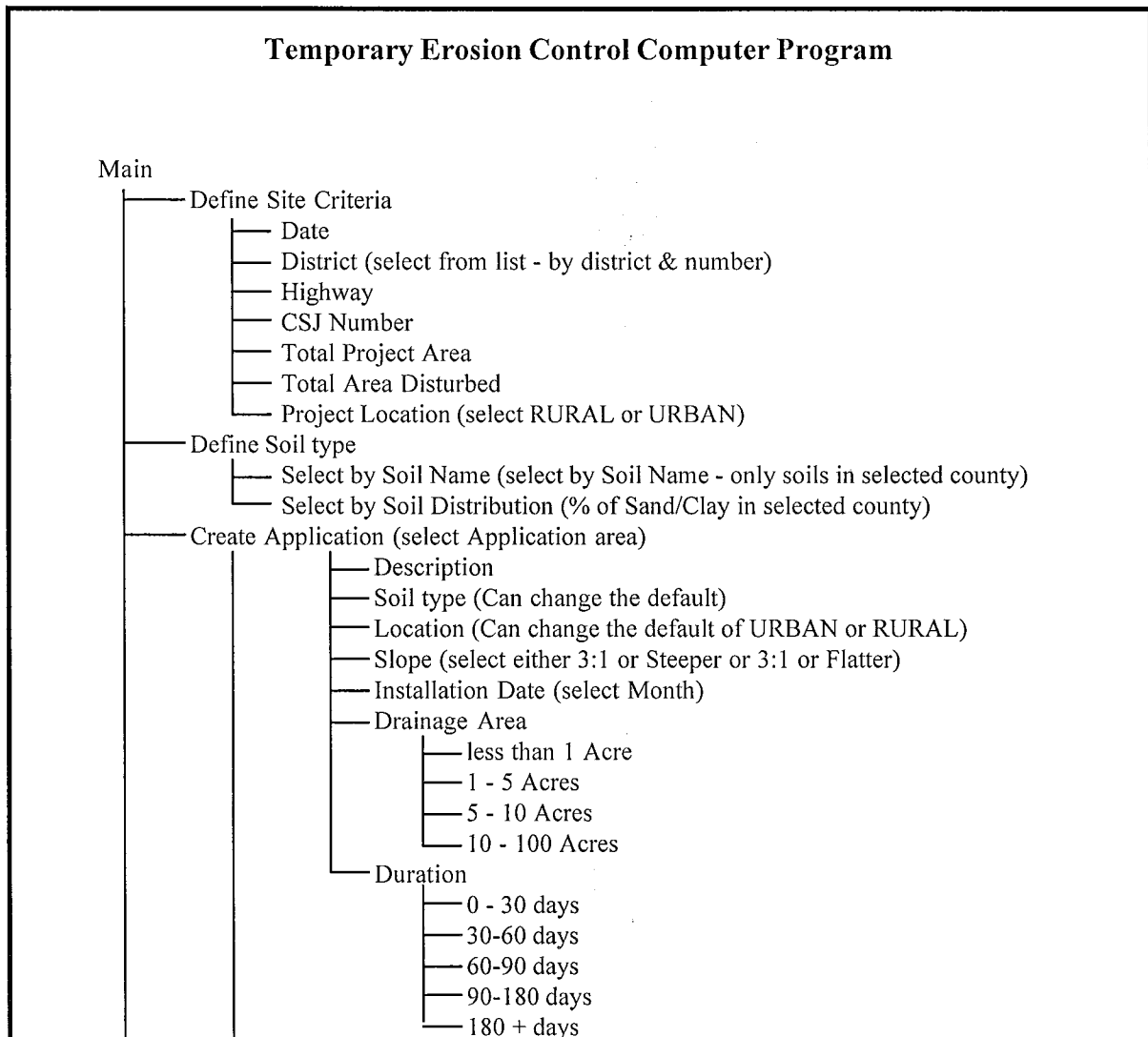
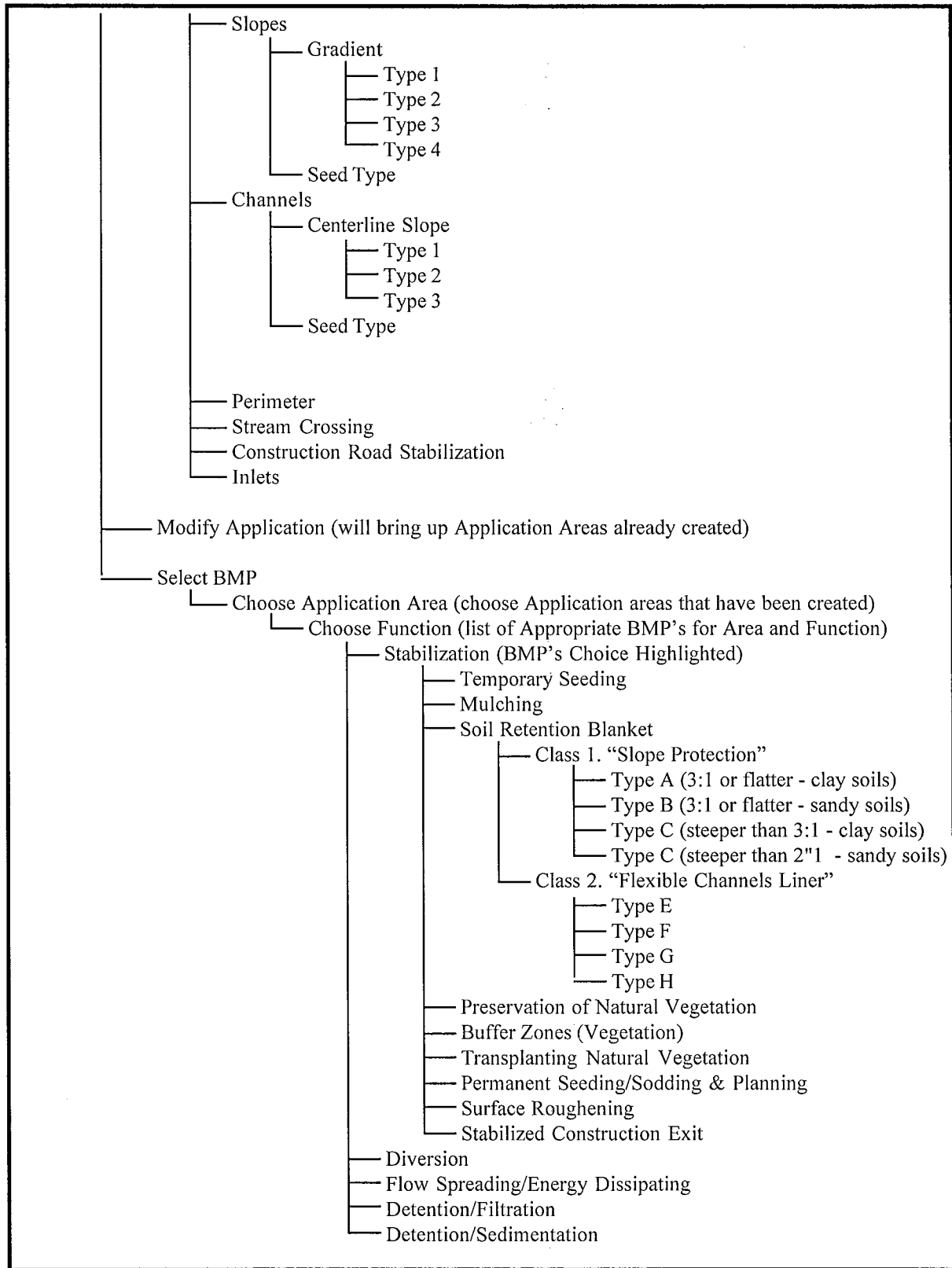

Figure 3 - continued.





## EROSION AND SEDIMENT CONTROL RESEARCH AGENDA

TxDOT is a leading transportation agency for their continuing efforts in erosion control research and facilities. The TxDOT/TTI Hydraulics and Erosion Control Laboratory is a unique facility dedicated to erosion control research for highway roadsides. Efforts by the Stormwater Advisory Task force showed TxDOT's pro-active involvement in meeting tougher environmental requirements. As a part of this research study, an objective necessary to maintain TxDOT's current leadership position is the development of a coordinated erosion and sediment control research agenda. This agenda should meet the long-range goals of the Department and the immediate needs of the districts by addressing the following issues:

- Incorporate the findings of this research study into TxDOT's Stormwater Guidance Program in 1994.
- Initiate research that would continue for a five year duration on the most cost effective practices known that include:

Mulches (breakdown points on varying slope gradients),  
Tackifiers,  
Recycled materials for different functions and application areas,  
Degradable materials,  
Bio-engineering for different functions and application areas, and  
Soil binders.

- Develop a program of continuing education and information exchange to begin as soon as possible. This may be accomplished by developing educational courses, videos, computer billboard, and interactive media for project designers, construction and maintenance engineers, and administration. These users would benefit from having current technical information, problem solving exchanges, and policy guidance to meet TxDOT's ever changing environmental requirements.

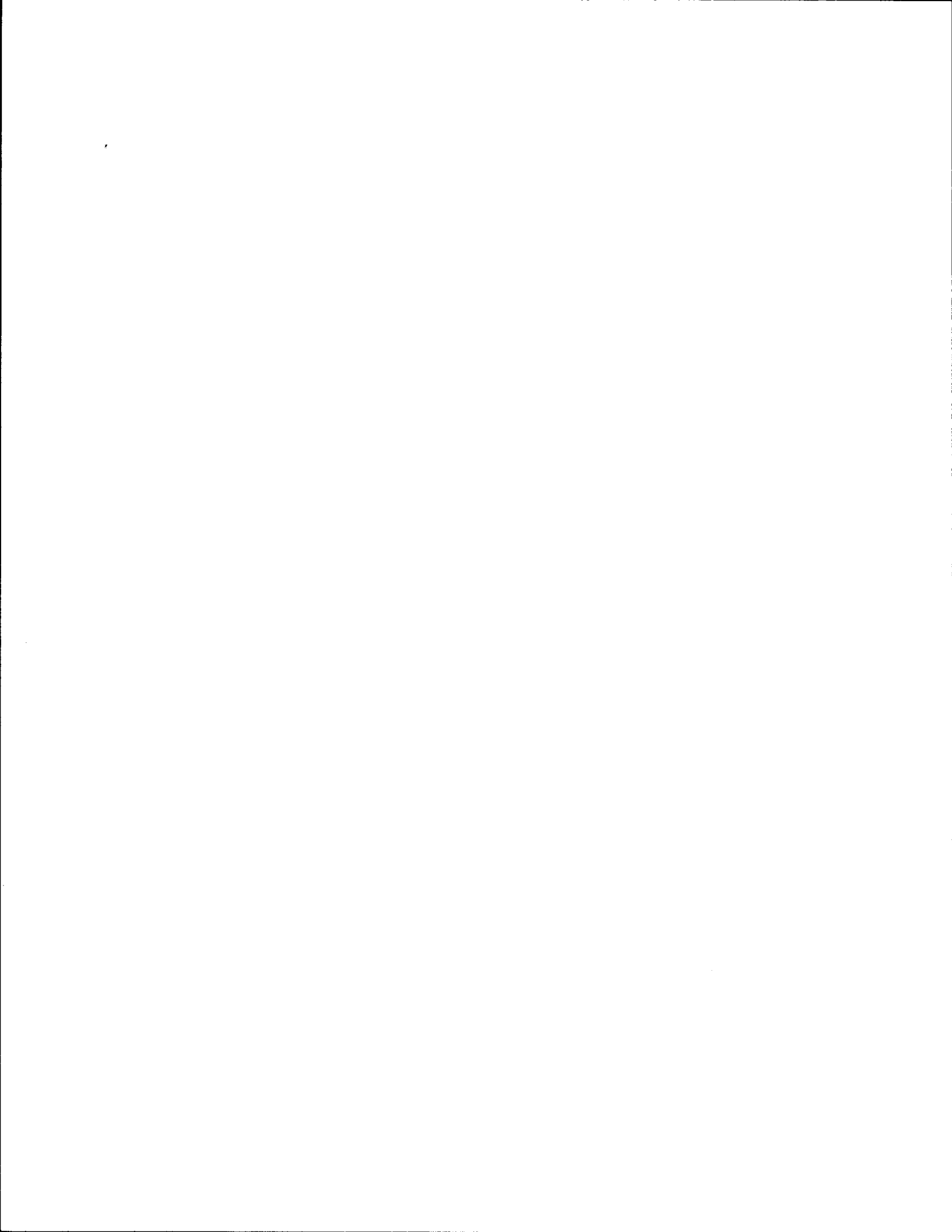

## REFERENCES

1. Anacostia Restoration Team, Department of Environmental Programs, Metropolitan Washington Council of Governments (1992). **A Current Assessment of Urban Best Management Practices: Techniques for Reducing Nonpoint Source Pollution in the Coastal Zone.** Metropolitan Washington Council of Governments.
2. Armstrong, J.J., Wall, G.J. (1993). **The Effective Use of Surficial Erosion Control Materials in the Planning and Design of Highways.** Ontario Ministry of Transportation, Research and Development Branch. MAT-92-06.
3. Armstrong, J.J. (1992). **Protocol for the Testing of Surficial Erosion Control Materials.** (Revised) Ontario Ministry of Transportation, Research and Development Branch. MAT-92-07.
4. Armstrong, J.J., Wall, G.J. (1990). **Quantitative Evaluation of the Effectiveness of Erosion Control Materials.** Ontario Ministry of Transportation, Research and Development Branch. MAT-90-10.
5. Armstrong, J.J., Wall, G.J. (1991). **Comparative Evaluation of the Effectiveness of Erosion Control Materials.** Ontario Ministry of Transportation, Research and Development Branch. MAT-91-05.
6. Armstrong, J.J., Wall, G.J. **Comparative Evaluation Of The Effectiveness Of Erosion Control Materials.** University of Guelph, Canada.
7. Barrett, Michael E., Zuber, Robert D., and Collins, E.R., III. (1993). **A Review And Evaluation Of Literature Pertaining To The Quantity And Control Of Pollution From Highway Runoff And Construction.** Center for Transportation Research, The University of Texas at Austin. CRWR 239.
8. Berthelsen, Gene. (1989). "Erosion Control," AASHTO Quarterly, Vol. 68. No. 2. American Association of State Highway and Transportation Officials. pp. 6-7.
9. Better Roads. (1988). "Geomatrix Aids Soils Erosion Problem," Vol. 58. No. 3. p. 38.
10. Birch, Peter B., Ph.D., Pressley, Helen E. and Hartigan, Patrick D. (1992). **Stormwater Management Manual for the Puget Sound Basin.** (The Technical Manual) Washington State Department of Ecology. 71-75.

11. Christopher, B.R., Holtz, R.D. (1992). **Current Research on Geosynthetics**. Bureau of Reclamation, Department of the Interior.
12. City of Austin, **Drainage Criteria Manual**, (1993), Austin, Texas.
13. City of Austin, **Environmental Criteria Manual**, (1991), Austin, Texas
14. Civil Engineering. (1988). "Ten Tip Projects For 1988," Civil Engineering, pp.68-71.
15. Clary, Raimond F. Jr., and Slayback, Robert D. (1984). "Plant Materials and Establishment Techniques for Revegetation of California Desert Highways," Transportation Research Board. No. 969. pp. 24-26.
16. Clyde, C.G., Israelsen, C.E., and Packer, P.E. (1976) **Erosion Control During Highway Construction**. National Cooperative Highway Research Program. Utah State University, Water Research Laboratory, NCHRP Project 16-3, Vol. 1,2,&3.
17. Colorado Department of Highways. (1978). **Erosion Control Manual**. Colorado Department of Highways.
18. Coppin, N., Richards, I.G. (1990). **Use of Vegetation In Civil Engineering**. Construction Industry Research and Information Association.
19. Donnelly, Denis E. (1986). **Evaluation of Plastic Erosion Control Mat-Project RS 0133(11)**, Final Report. Colorado Department of Highways. CDOH-DTP-R-86-17.
20. Driscoll, Eugene D., Shelley, Philip E. and Strecker, Eric W. (1990). **Pollutant Loadings And Impacts From Highway Stormwater Runoff-[Volume I: Design Procedure.]** Office of Engineering and Highway Operations R&D, Federal Highway Administration. FHWA-RD-88-006.
21. Driscoll, Eugene D., Shelley, Philip E. and Strecker, Eric W. (1990). **Pollutant Loadings And Impacts From Highway Stormwater Runoff-[Volume IV: Research Report Data Appendix.]** Office of Engineering and Highway Operations R&D, Federal Highway Administration. FHWA-RD-88-009.
22. Freer, R. (1991). "Bio-engineering: the use of vegetation in civil engineering," Construction & Building Materials, Vol. 5 No. 1, Butterworth-Heinemann Ltd. pp. 23-26

23. Godfrey, S.H., Landphair, H.C., Long, J.P., and McFalls, J.A. (1993). **The Performance of Flexible Erosion Control Materials.** Texas Department of Transportation Research Program, Texas Transportation Institute, Hydraulics and Erosion Control Laboratory, Study No. 2-18-90-1914. Research Report 1914-1.
24. Goldman, S.J., Jackson, K. (1986). **Erosion and Sediment Control Handbook.** McGraw-Hill Book Co. Inc.
25. Harding, Michael V., C.P.E.S.C. (1993). **Practical Approaches for Effective Erosion and Sediment Control.** International Erosion Control Association.
26. Haynes, John F. (1991). **Effectiveness of Legume Seeding For Erosion Control.** California Department of Transportation. FHWA/CA/TL-91-06.
27. Heine, Martha. (1990). "Blankets help control diminishing soil on slopes," Roads & Bridges. p. 55.
28. Horner, Richard R., Guedry, Juno., and Korten Hof, Michael H. (1990). **Improving the Cost Effectiveness of Highway Construction Site Erosion and Pollution Control,** Final Report. Washington State Department of Transportation. WA-RD 200.1.
29. Horner, Richard R., Guedry, Juno., and Korten Hof, Michael H. (1990). **Highway Construction Site Erosion And Pollution Control Manual.** Washington State Transportation Center. WA-RD 200.2.
30. International Erosion Control Association. (1994). **"Sustaining Environmental Quality: The Erosion Control Challenge."**
31. International Erosion Control Association. (1993). **"Preserving Our Environment-The Race Is On."**
32. International Erosion Control Association. (1990). **Erosion Control: Technology in Transition.**
33. Israelsen, C.E., Clyde, C.G., (1980). **Erosion Control During Highway Construction: Manual on Principles and Practices,** National Cooperative Highway Research Program. Utah State University, Water Research Laboratory, NCHRP Report 221.
34. Jagielski, Kevin. (1991). "Erosion-Control Market Takes Hold," Geotechnical Fabrics Report. Vol. 9. Industrial Fabrics Association International. pp. 14-15.

35. Karcz, Dean A., Holtz, Robert D. (1988). **Development Of The IDOH Classification System For Geotextiles**, Final Report. Purdue University, West Lafayette, Indiana. C-36-674, 9-11-25.
36. Kuennen, Tom. (1992). "Turnpike ditches lined with 3D nylon matting," Roads & Bridges. Vol. 30. No. 2. Scranton Gillette Communications, Inc. p. 40.
37. LaForce, Robert F. (1983). **Fill Slope Erosion Control, I-70 Straight Creek Corridor, Project I-70-3(99)**, Final Report. Colorado Department of Highways. CDH-DTP-R-82-2.
38. Litton, L.L. and Lohnes, R. A. (1982). "Soil-Cement for Use in Stream Channel Grade-Stabilization Structures," Transportation Research Board. No. 839. pp.33-38.
39. Lorant, Ivan F. (1992). **Highway Runoff Water Quality-Literature Review**. Ontario Ministry of Transportation, Research and Development Branch. MAT-92-13.
40. Lorant, Ivan F. (1992). **Effects of Piped Median vs. Open Ditch Drainage on Stormwater Quality**. Ontario Ministry of Transportation, Research and Development Branch. MAT-92-04.
41. Mandal, J.N., Murti, M.V.R. (1988). **The Geojute Edge. Reinforced Soil and Geotextiles**, Proceedings of the Geotextiles conference Held at the Indian Institute of Technology, Bombay, India. Balkema (AA).
42. Mason, John M., Rhomberg, Edward J. (1980). **Urban Stormwater Management - On-Site Detention**. Texas Engineering Extension Service, Texas A&M University. PWP: 0355-01.
43. Miles, Thomas R., Burt, J., Hale, K. and Lofton, J. (1989). "Emergency Watershed Protection Using Straw Bales," Public Works. Vol. 120. pp. 32-35.
44. Mitchell, G.F. (1993). **Assessment of Erosion/Sediment Control in Highway Construction Projects**, Final Report, Appendix C and D. Ohio University, Athens; Center for Geotechnical and Environmental Research. FHWA/OH-93/011.
45. Mitchell, G.F. (1992). **Assessment of Erosion/Sediment Control in Highway Construction Projects**, Final Report. Ohio University, Athens; Center for Geotechnical and Environmental Research. FHWA/OH-93/011.
46. North Carolina Department of Environment, Health and Natural Resources (1991). **Erosion and Sediment Control-Field Manual**.

47. North Carolina Sedimentation Control Commission (1988). **Erosion and Sediment Control- Planning and Design Manual.**
48. Northcutt, Paul E. (1988). **Field Performance, Testing And Comparison Of Mulching Materials.** Texas State Department of Highways and Public Transportation, Safety and Maintenance Operations Division.
49. Pitt, Robert E. (1991). **A Detention Pond Manual Of Practice - Design Guidelines and Background Information For Designing Wet Detention Ponds for Stormwater Quality Control.** Department of Civil Engineering, The University of Alabama at Birmingham.
50. Prokop, P. (1992). **Proceedings, Second Interagency Symposium on Stabilization of Soils and Other Materials.** United States Bureau of Reclamation.
51. Promise, John P.E. (1993). **Storm Water Quality Best Management Practices For Construction Activities,** First Edition. North Central Texas Council of Governments.
52. Public Works. (1988). "Erosion Control Blankets Help Eliminate Eyesore," Vol. 119. pp.82-88.
53. Richards, Dennis L., Middleton, Lloyd M. (1978). **Best Management Practices for Erosion and Sediment Control.** Federal Highway Administration, Region 15-Design Division. FHWA-HD-15-1.
54. Rickson, R.J. (1988). **Geotextiles for Soil Erosion Control--An Introduction to Biotechnical Engineering.** Plants as Engineering Structures in the Control of Soil Erosion and Stabilization of Slopes. Cambridge Bio-Soil Engineering LTD.
55. Rudolph, Raymond L. P.E., Dowell, James. (1988). "Erosion Control Fabric Saves \$90,000," Vol. 119, Public Works. pp. 68-77.
56. Sauli, G. (1989). **Biological Engineering Construction Methods for Vegetation.** Proceedings of the International Symposium: Road Development and Safety. Institut National de Recherche Routiere.
57. Stein, E.G. Jr. (1990). "Erosion and Sediment Control, The Maryland Way," Vol. 121. No. 13. Highway and Heavy Construction. Cahners Publishing Company. pp. 54-56.

58. Stockdale, Erik C. (1991). **Freshwater Wetlands, Urban Stormwater, And Nonpoint Pollution Control: A Literature Review And Annotated Bibliography**, Second Edition. Washington State Department of Ecology.
59. Sykes, Robert D., ASLA (1986). **Channels and Ponds**.
60. Technical Services Bureau of the Department of Conservation and Recreation's Division of Soil and Water Conservation (1992). **Virginia Erosion and Sediment Control Handbook**, Third Edition.
61. Tetra Tech, Inc. (1989). **National Symposium On Water Quality Assessment, Meeting Summary**. United States Environmental Protection Agency.
62. Tetteh-Wayoe, Helen. (1991). "Environment Friendly Solutions To Erosion Control In Alberta," Vol. 1. **Proceedings of the 1991 Annual Conference of the Transportation Association of Canada, Winnipeg, Manitoba**. Transportation Association of Canada. pp. A83-A99.
63. Texas State Department of Highways and Public Transportation (1977). **Thysys, Texas Hydraulic System**, User Manual.
64. Theisen, Marc S. (1992). "Geosynthetics in erosion and sediment control," Vol. 10. **Geotechnical Fabrics Report**. pp. 26-35.
65. Theisen, M.S. (1992). **The Expanding Role of Geosynthetics in Erosion and Sediment Control**. Bureau of Reclamation, Department of the Interior.
66. U. S. Department of Agriculture, Soil Conservation Service. (1976). **Erosion and Sediment Control Guidelines**: For Developing Areas of Texas. SCS Temple, Texas.
74. U.S. Department of Transportation, Federal Highway Administration. (1988). "Design Of Roadside Channels With Flexible Linings," **Research, Development, and Technology**.
67. Wall, G.J. (1991). **Erodibility of Reconsolidated Topsoil and Subsoil Materials used in Highway Construction**. Ontario Ministry of Transportation, Research and Development Branch. MAT-91-06.
68. Wall, G.J. (1991). **The Effectiveness of Surficial Erosion Control Products**. Ontario Ministry of Transportation, Research and Development Branch. MAT-91-07.



69. Watschke, Thomas L. **The Effect Of Nutrients And Pesticides Applied To Turf On The Quality Of Runoff And Percolated Water.** Environmental Resources Research Institute. ER 8904.
70. Wischmeier, W.H., Johnson, C.B., and Cross, B.V. (1971). **Soil Erodibility Nomograph for Farmland and Construction Sites.** Soil and Water Conservation Journal. Vol. 26. pp. 189-193.
71. Wyant, David C. (1993). **Developing VTM-51 into an ASTM Test Method.** Virginia Department of Transportation. FHWA/VA-94-R2.
72. Wyant, David C. "Evaluation of Filter Fabrics for Use in Silt Fences," **Transportation Research Board.** No. 832. pp.6-12.
- 73.. Wyant, David C., Sherwood, W.C. and Walker, Hollis N. **Erosion Prevention During Highway Construction By The Use of Sprayed On Chemicals.** Virginia Highway Research Council. PB 213 207.
74. Yu, Shaw L. (1993). **Stormwater Management For Transportation Facilities.** Transportation Research Board, National Research Council. 174.
75. Yu, S.L., Barnes, Gerde, V.W. (1993). **Testing of Best Management Practices for Controlling Highway Runoff.** Virginia Transportation Research Council. FHWA/VA-93-R16.
76. Zellner, Stanley D., Taylor, John D., Conte, Donald J., and Gaynor, Allen J. (1987). **Erosion Control On Steep Slopes Following Pipeline Construction.** National Technical Information Service. DE88 002882.
77. Zwoyer, Eugene, Rogg, Nathaniel and Stahl, David E. (1979) **Residential Storm Water Management, Objectives, Principles, & Design Considerations.** The Urban Land Institute (ULI), The American Society of Civil Engineers (ASCE) and The National Association of Home Builders (NAHB).
78. U.S. Department of Agriculture, Soil Conservation Service. (1976). **Erosion and Sediment Control Guidelines: For Developing Areas in Texas.** SCS Temple, Texas.

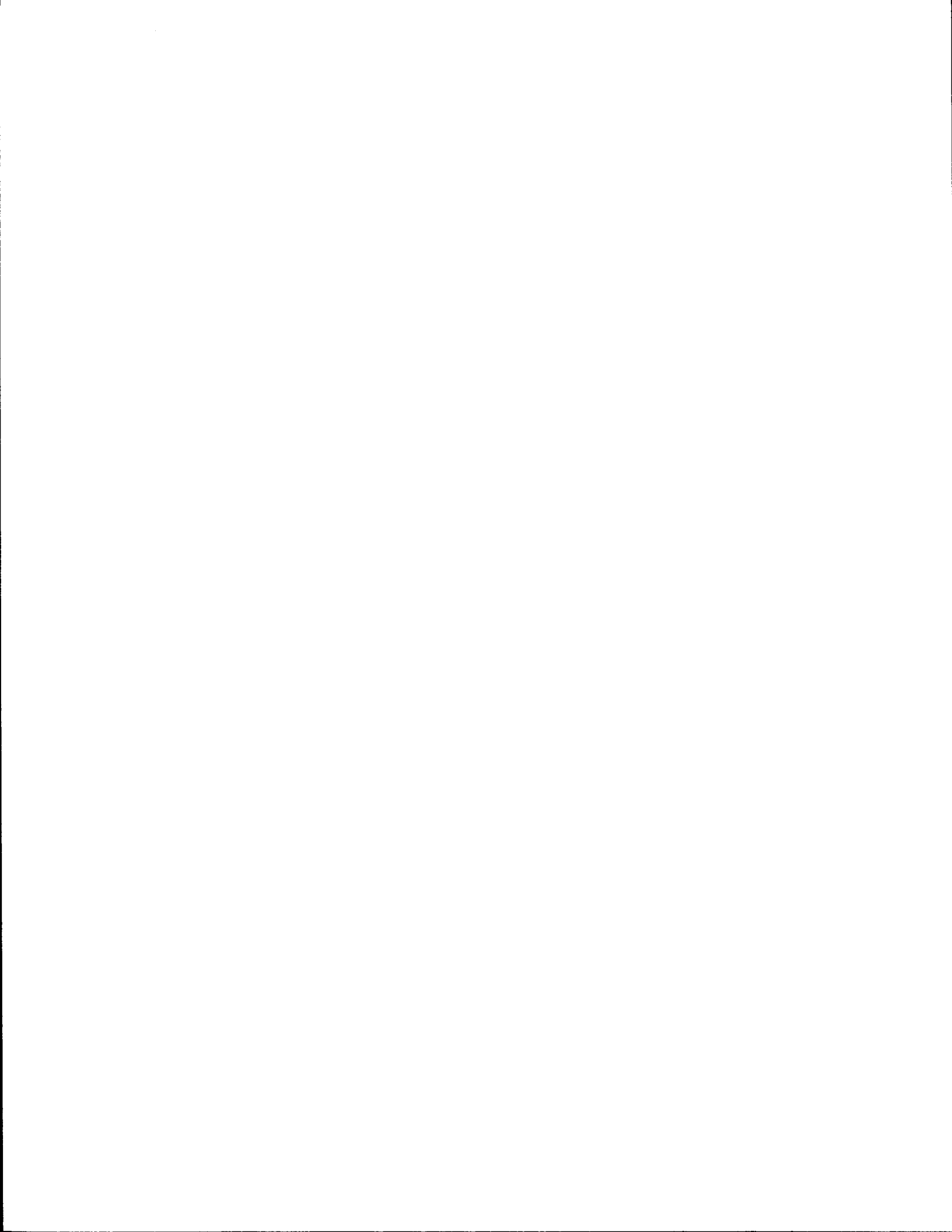

## APPENDIX A

### GLOSSARY OF EROSION AND SEDIMENT CONTROL TERMS

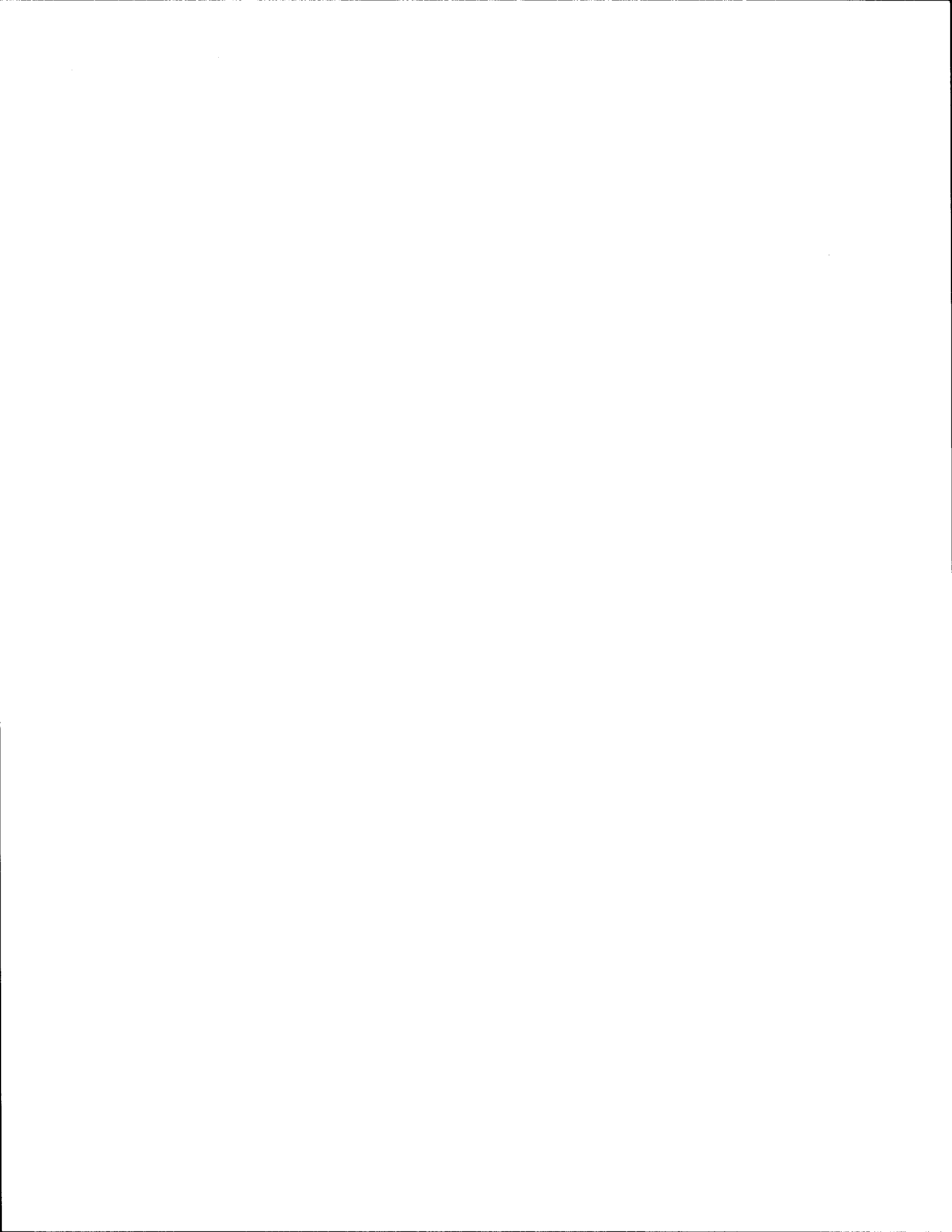

Glossary	Definition
<p><b>Barriers</b></p> <p>Other terms include berms, check dams, diversion dikes, erosion stops, windrows, interceptor dike, perimeter dike, hay bale dike, sediment control fence, triangular sediment filter dikes, sausages</p>	<p>An impediment to surface water that is placed on or near a contour along the surface to be protected (slopes or channels). Barriers may also be used to divert surface water flow to a stabilized outlet. Various materials may be utilized depending upon the quantity and depth of water and local availability of materials. Common barrier materials include brush, compacted earth, gravel, hay, rock, sand bags, silt fences and straw bales.</p>
<p><b>Benches</b></p> <p>Other terms include terracing</p>	<p>A method to reduce slope lengths by constructing level terraces 3-6 m (10-20 ft) wide at intervals 15-30 m (50-100 ft) down the slope. Benches will reduce water velocities and increase infiltration. Slopes should be stabilized with vegetation upon completion of the benches.</p>
<p><b>Berms (see Barriers)</b></p> <p>Other terms include brush berms, rock berms, sandbag berms, earth berms, sausages</p>	<p>Typically used in reference to slope barrier measures designed to break the continuity of slopes to reduce runoff velocities.</p>
<p><b>Brush Mats (see Revetments)</b></p>	<p>Streambank protection measure.</p>
<p><b>Buffer Zone</b></p> <p>Other terms include vegetative buffer strips, vegetative buffer zones</p>	<p>The zone contiguous with a sensitive area that is required for the continued maintenance, function, and structural stability of the sensitive area. Different types of buffers are required for riparian buffers associated with an aquatic system or terrestrial buffers.</p>
<p><b>Channel, constructed</b></p> <p>Other terms include interceptor swales, perimeter swales, ditches, flumes, chutes, diversion ditch</p>	<p>A method used to convey surface water from points of concentration across, through, along, and around highway rights-of-way or other areas to be protected.</p>

<b>Channel stabilization</b>	Materials used to stabilize the channel surface should be selected in relationship to the channel use (temporary or permanent) and calculated shear stresses. Typically, for non-structural cover use soil retention blankets with the appropriate seeding mixture. For structural cover use concrete or riprap (rock).
<b>Check dams (see barriers)</b>  Other terms include rock filter dam	Typically used in reference to channel barrier measures to temporarily detain sediment-laden water which allows suspended solids to settle. Common dam materials include rock, logs, logs and hay, rock and sediment control fence, staked bales, straw bales and sediment control fence, and sheet piling.
<b>Chutes (see Channel, constructed)</b>  Other terms include down drain	Used to convey water down slopes and are constructed with materials suited to the expected life of the chute (ie., concrete for permanent chutes).
<b>Cofferdam</b>	Used to divert water from structures or stream bank segments during construction to prevent sediment from entering adjacent streams. Materials used are concrete, earth, steel, supported plastic sheet, and wood.
<b>Concrete splash pads (see energy dissipators)</b>	
<b>Construction exit (see stabilized construction exit)</b>	
<b>Diversion dike (see barrier)</b>	Used to intercept runoff from small upland areas to protect the slope face.
<b>Diversion ditch (see channel, constructed)</b>	Typically constructed at the upper edges of cut slopes to collect water from adjacent properties and divert it around the cut.
<b>Drain (see channel or pipe)</b>  Other terms include down drains, drop structures - pipe drop and box drop	Used to conduct runoff down a slope. Methods used are open channel or closed conduit (pipe). See channel stabilization or pipe for materials.
<b>Drop Box (see Drain)</b>	Includes a culvert inlet-box with vertical sides. Used as an energy dissipator by reducing the velocity in the culvert. Usually is a permanent structure except when used with temporary sediment basins. Typical construction materials include steel, wood, or concrete.

<p><b>Energy dissipators</b></p> <p>Other terms include gabions, concrete splash pads, drop structures, stone outlet structures, and riprap</p>	<p>Any means to reduce the total energy of flowing water especially high-velocity flows. In stormwater design, they are usually mechanisms that reduce velocity prior to, or at, discharge from an outfall in order to prevent erosion. Materials used include gabions, concrete splash pads, drop structures, riprap, and boulders.</p>
<p><b>Erosion stops (see barriers or check dams)</b></p>	<p>Term may refer to check dams constructed in channels or to overland flow control on mild slopes (&lt; 3:1). Materials used include hay bales, brush, gravel, snow fence, and straw.</p>
<p><b>Filter fabric</b></p>	<p>A woven or nonwoven, water-permeable material generally made of synthetic products such as polypropylene and used in stormwater management and erosion and sediment control applications to trap sediment or prevent the clogging of aggregates by fine soil particles. Filter fabric must be cleaned often to perform the filtering function.</p>
<p><b>Filter fabric fence</b></p> <p>Other terms include sediment control fence, silt fence, silt barriers, sediment fence</p>	<p>A sediment barrier consisting of a filter fabric stretched across and attached to supporting posts and entrenched in the earth. Rigid wire is used as backing to provide additional support. Rock filter dams and filter fabric fences may be combined to decrease flow velocity, increase sediment settling, and allow a filtering process to occur.</p>
<p><b>Filter strip</b></p> <p>Other terms include vegetative buffer strip</p>	<p>Typically a long, relatively narrow area of undisturbed or planted vegetation used to retard or filter sediment for the protection of watercourses, drainage basins, diversions, reservoirs, or adjacent properties.</p>
<p><b>Floating sediment barrier</b></p>	<p>Used to retain suspended sediment within the disturbed area of a lake, pond, or stream. Typically the floating barrier is a plastic or other impermeable barrier suspended from floats tied together with a rope and anchored at each end to the shore. Vertically, the barrier extends from the water surface to within a few inches of the lake bed.</p>
<p><b>Flume (see channel, constructed and chutes)</b></p>	
<p><b>Gabions (see energy dissipator)</b></p> <p>Other terms include velocity control devices</p>	<p>Used as energy dissipators, channel liners, steep-slope protectors, and retaining walls. Gabions are rectangular or cylindrical wire mesh cage filled with rock and used as a protecting agent against erosion. Soft gabions (streambank stabilization) are made of geotextiles filled with soil, in between which cuttings (brush) are placed.</p>
<p><b>Hay Bale Dikes (see barriers)</b></p>	<p>Typically used as a slope barrier control measure for short durations of time (2 months or less).</p>
<p><b>Hydromulching (see mulching or seeding)</b></p>	<p>Mechanical method to apply seed, fertilizer, and mulch in a water slurry for soil stabilization.</p>

<b>Inlets</b>	A form of connection between surface of the ground and a drain or sewer for the admission of surface and stormwater runoff. Temporary inlets may be constructed of rock and earth, hay/straw bales, wood, and other available materials. Permanent inlets are usually constructed of concrete.
<b>Interceptor dike</b> (see barrier)  Other terms include diversion dike, triangular sediment filter dikes	Used to direct surface flow (from slopes) to a desired collection point. Constructed from materials that will withstand the flows.
<b>Interceptor ditches, swales, or drains</b> (see channel, constructed)	Used to divert the course of flow of surface runoff and direct it to a desirable collection or runoff point. Protection of the interceptor ditch surface is similar to that of most channels (ditches) to prevent erosion of the ditch.
<b>Jetties</b>	Used to deflect water currents away from selected sections of a stream bank or shore. Similar concept to a interceptor dike only applied to stream stabilization. Common materials used are brush, logs, pile, and riprap.
<b>Level spreader</b>	A temporary method to convert channel or pipe flow to sheet flow to prevent concentrated, erosive flows from occurring, and to enhance filtration. Filter strips are often used in conjunction with a level spreader.
<b>Mulching</b>  Other terms include hydromulching	Application of plant residues or other suitable materials to increase infiltration, decrease runoff, protect soil surface from erosive forces of rainfall and wind, and to foster vegetative growth. May be applied by machinery or by hand using either water or air as the carrying agent. Mulches may be combined with the seed (and fertilizer), after seeding operations, or alone for temporary use where vegetation establishment is not desired. Common materials used as mulches include cellulose fiber, gravel, hay, rice hulls, sawdust, shredded paper, straw, vegetative fodder, wood chips, and wood fibers.
<b>Mulch anchoring</b>  Other terms include tackifiers, asphalt tacking	Method used to increase the effectiveness of mulch against surface erosion by water and wind. Binding agents referred to as tackifiers are mixed with the mulch in a water slurry prior to application, sprayed on top of the mulch material by mechanical machinery after the mulch application, or are sold as an integral part of the mulch product.
<b>Perimeter dike</b> (see barrier)	The term implies the location of the dike (barrier) which is used to prevent off-site water from entering the site or vice versa.
<b>Perimeter swale</b> (see channel, constructed)	The term implies the location of the swale (channel) which is used to prevent off-site runoff from entering the site or sediment-laden runoff from leaving the site.
<b>Permanent seeding</b>	Refers to the establishment of perennial warm-season grasses for the stabilization of disturbed soils. Well defined and proven establishment guidelines must be followed for successful establishment of grasses. The use of mulches and soil retention blankets aid in the critical period in root development by retaining soil moisture, trapping soil particles, and protecting the seed bed from the erosive forces of wind and rain.



<b>Permanent sodding</b>	Refers to the establishment of perennial warm-season grasses for the stabilization of disturbed soils by placing a layer of sodding on the disturbed area. Proven establishment guidelines must be followed for successful establishment of grasses.
<b>Permanent planting</b>	Method used to establish permanent plants (trees, shrubs, and groundcovers) for the stabilization of disturbed soils. Consultation with a landscape architect should be done prior to planting.
<b>Pipe</b>	A closed conduit for conveyance of water. Materials may be flexible pipe or rigid pipe.
<b>Pipe outlet protection</b>	Outlets should be protected to complete the transition between open channel flow and pipe flow. Pipe outlet protection may be provided by energy dissipators, channel protection (non-structural and structural methods), or a combination of the two.
<b>Pipe slope drain (see pipe)</b>	The term implies the location of the pipe which is to drain surface water safely down slopes without causing erosion.
<b>Pollution</b>	Contamination or alteration of the physical, chemical, or biological properties, or waters of the state, including change in temperature, taste, color, turbidity, or odor of the waters, or such discharge of any liquid, gaseous, solid, radioactive or other substance into any waters or the state as will or is likely to create a nuisance or render such waters harmful, detrimental or injurious to the public health, safety, or welfare, or to domestic, commercial, industrial, agricultural, recreational, or other legitimate beneficial uses, or to livestock, wild animals, birds, fish or other aquatic life.
<b>Preservation of natural vegetation</b>  Other terms include buffer zones, vegetative buffer zones	Management activity to minimally disturb the natural vegetation during the construction project.
<b>Revetments</b>  Other terms include rock revetment, gabions	Used as bank protectors in streams. Revetments may be constructed from a variety of materials depending upon local availability and erosive force reduction required. Materials include brush mats, rock, concrete rubble, logs, and cellular concrete block.
<b>Riprap, rubble</b>	Used as an energy dissipator, or surface or channel protector which consists of a facing layer of stones or concrete rubble to prevent sloughing of a structure or embankment due to flow of surface and stormwater runoff. Used in this context, riprap does not refer to the concrete riprap used in highway structures around bridge abutments or as a channel liner in drainage structures.
<b>Rock filter dam (see check dam or barrier)</b>	Usually referring to channel barrier measure to temporarily detain sediment-laden water. May refer to slope protection measure to slow down sheet flow of sediment-laden runoff from disturbed areas.
<b>Rock revetment (see revetment)</b>	

<p>or <b>Sausage</b> (see barrier berms)</p>	<p>Generally sausages are used in stream stabilization much like a dam to dissipate the flow of the stream. They are also used on steep slopes as a barrier control to dissipate the sheet flow with high velocities. Sausages usually consist of rocks or sand bound together with a plastic, wire, or burlap mesh (gabion-like). The physical dimensions depend upon the application area and have been designed from a few inches to several feet.</p>
<p><b>Sediment basin</b></p>	<p>Sediment basins control or stop sediment after it has eroded. Basins consist of a barrier or dam with a controlled stormwater release structure, and water storage space. They are used to detain sediment-laden runoff from drainage areas 1.2 ha (3 ac) or greater for enough time to allow most of the suspended solids to settle out. Maximum effective life is approximately 18 months unless designed as a permanent pond.</p>
<p><b>Sediment control fence</b></p> <p>Other terms include silt fence, filter fabric fence</p>	<p>A sediment barrier consisting of a filter fabric stretched across and attached to supporting posts and entrenched in the earth. Rigid wire is used as backing to provide additional support. Rock filter dams and filter fabric fences may be combined to decrease flow velocity, increase sediment settling, and allow a filtering process to occur.</p>
<p><b>Sediment trap</b></p> <p>Other terms include catch basin, temporary sediment traps, traps</p>	<p>Generally, sediment traps are smaller versions of sediment basins. Construction should be as simple as possible utilizing locally available materials and machinery. They are made by digging holes in drainageways and constructing small dams of wood, stone, bales, etc. across channels, culvert inlets, and other low areas to allow most of the suspended solids to settle out.</p>
<p><b>Seeding</b></p>	<p>Method to establish primarily grasses and legumes as vegetative erosion control (non-structural). Seeding may be accomplished by broadcasting, drilling, hydroseeding and in conjunction with soil retention blankets or mulches. Seeding mixtures and rates have been established for temporary and permanent vegetative establishment based upon the optimal planting windows and type of roadside (urban or rural) for each district.</p>
<p><b>Soil Retention Blanket</b></p> <p>Other terms include erosion control blankets and mats, jute netting, excelsior blanket, straw blankets</p>	<p>Material utilized as a surface and channel protection in conjunction with seeding. Soil retention blankets are anchored in the ground to increase the soil/blanket contact. TxDOT/TTI conduct performance research to provide current information on various product performance in a field evaluation situation.</p>
<p><b>Stabilized Construction Exit</b></p> <p>Other terms include temporary structural construction entrance, construction exit</p>	<p>Stabilization of exposed soil at construction exits to reduce or eliminate sediment from leaving the construction site by tracking or flowing. Common materials used are aggregate cover and timber.</p>

<p><b>Stone outlet structure</b> (see energy dissipator)</p> <p>Other terms include filter berm, brush berm, baled hay or straw berms, rock or gravel dams, sediment basin outlet, sediment trap</p>	<p>Crushed stone <u>filter dam</u> used in conjunction with other controls such as diversion, interceptor, or perimeter dikes, pipe slope drains, or sediment traps and basins to provide a protected outlet for any measure that requires velocity dissipation and diffusion of concentrated flow. Filters can be constructed from any porous material that can be stabilized in rows, banks, or mounds. They must be maintained to be effective.</p>
<p><b>Stream bank protection</b></p>	<p>Measures used to protect the existing stream banks from eroding which include the use of large material masses or smaller anchored structures such as large boulders, brush mats, log jacks, concrete rubble, or special concrete and or steel structures.</p>
<p><b>Surface roughening</b></p> <p>Other terms include roughened surface, tracking</p>	<p>Grading method used to stair-step, groove, or leave slopes in a roughened condition by not fine-grading. This activity reduces runoff velocity, provides sediment trapping, and increases infiltration, all of which facilitate vegetation establishment on exposed slopes. Also referred to as roughened surface or tracking.</p>
<p><b>Temporary seeding</b> (see seeding)</p>	<p>Refers to the use of soil stabilization with grasses that will establish quickly and have a longevity of one year or less. Well defined and proven establishment guidelines must be followed for successful establishment of grasses.</p>
<p><b>Terracing</b> (see benches)</p>	<p>Grading technique to reduce slope length for slope stabilization.</p>
<p><b>Tubelings</b></p>	<p>A vegetation establishment technique which eliminates the need for irrigation during plant establishment. Plants are grown in paper tubes reinforced by plastic mesh sleeves. These "tubelings" are planted in holes drilled into the ground. Success rate is questionable.</p>
<p><b>Wattles</b></p> <p>Other terms include brush wattles, straw wattles</p>	<p>Bio-engineering technique used for stabilizing fill slopes that requires hand labor. Leafy brush, straw or both are packed into a "cable" usually 304.8 mm (12") wide and 254 mm (10") thick and laid in trenches dug into the slope face along the contours. Stakes are used as anchors for the wattles. Live cuttings are planted between the wattles rows and the entire area is seeded. Typically used to protect fill slopes along streams from rain and wind erosion. Generally intended to be left as a permanent control.</p>
<p><b>Windrows</b> (see barriers)</p>	<p>Typically used at the top or bottom of slopes as a barrier control measure. Common to construct windrows by compacted earth during the grading process.</p>
<p><b>Windbreak</b></p>	<p>Used to control wind velocity near the ground surface level. Common materials include logs, lath, plank, and boards. Trees and shrubs can be effective windbreaks as well.</p>



## **APPENDIX B**

### **EXCERPTS FROM TXDOT'S STORM WATER MANAGEMENT GUIDELINES FOR CONSTRUCTION ACTIVITIES**

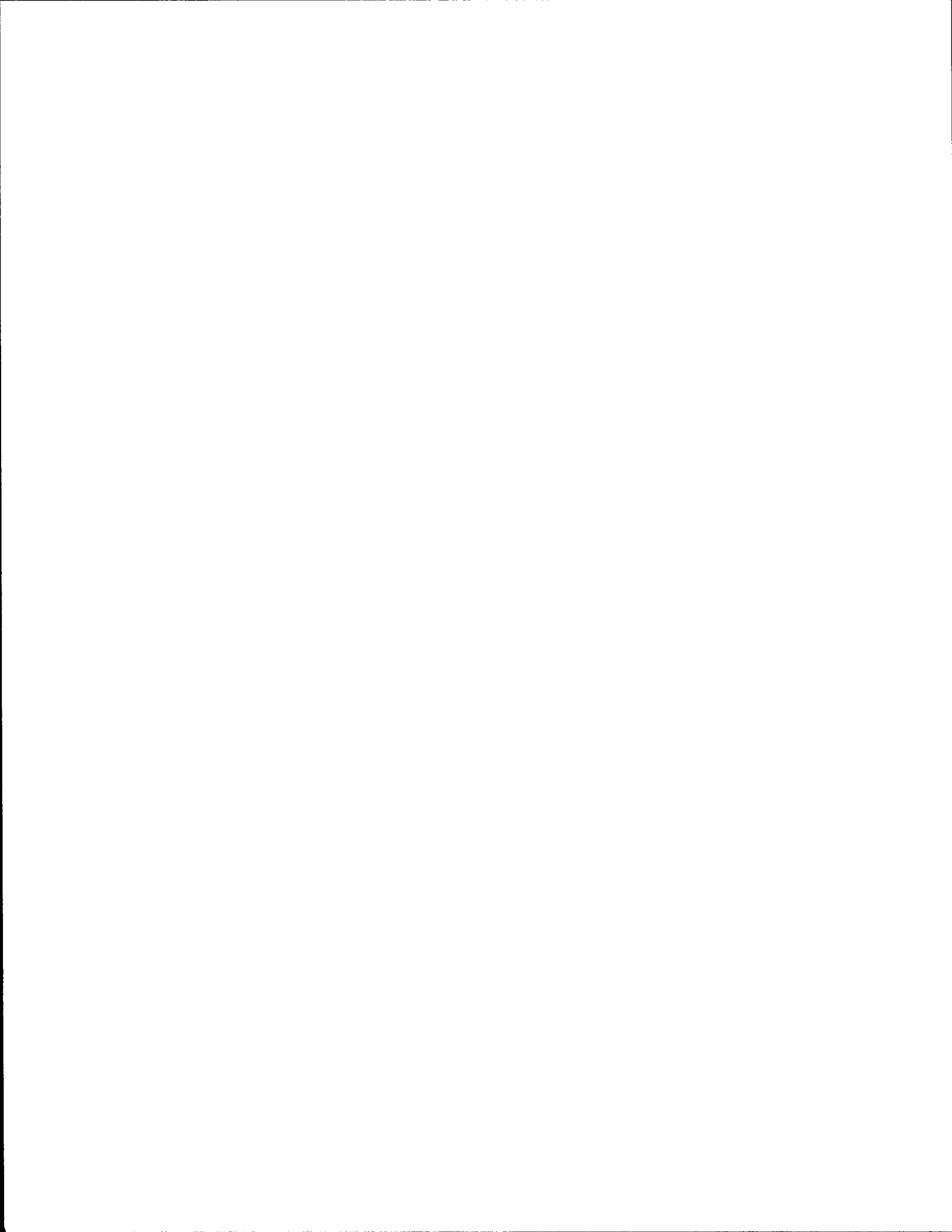

In adapting the USLE for use on highway projects the terms C and P are eliminated because they relate to agricultural lands and replaced with an erosion control factor VM. The L and S factors can be combined to form LS, the length-slope factor, which depends on the length and steepness of slope. Therefore a modified equation (Modified Universal Soil Loss Equation or MUSLE) is presented in this manual to predict soil loss due to erosion on highway construction sites and to determine the effectiveness of various erosion control devices.

$$A = R \times K \times LS \times VM \quad (2)$$

where:

A = rate of soil loss in tons per acre per year

R = rainfall erosion factor

K = soil erodibility factor

LS = length/slope factor

VM = erosion control factor (vegetative and mechanical measure)

#### Rainfall Erosion Factor (R)

The average annual rainfall erosion factor (R) (often referred to as the mean annual ISO erodent (R) value) varies dependent on region and time of year. It is a measurement of the erosive force of a specified rainfall event.

Appendix G contains a map indicating the mean annual ISO erodent (R) values for various regions of the country. These maps indicate the R value for the two year recurrence interval. R values for different storm frequencies may be adopted from Figure 3.1 and Appendix H (Erosion Index).

#### Soil Erodibility Factor (K)

The soil erodibility factor (K) is a numeric representation of the ability of the soil to resist the erosive forces of rain. Values of "K" range from 0.1 to 0.7 and may be found in most soil surveys. In the event the soil surveys do not contain values for K, use Appendix I which indicates more ranges of K based on location.

#### Topographic Factor (LS)

The only portions of the soil loss equation which can be affected by construction activities are LS and VM, the R and K values are fixed by nature and cannot be altered by man. The LS factor is a numerical representation of the length-steepness combination used to estimate the erosion potential

for a specific slope. Since the slope and length are determined during the design process, knowledge of the LS factor will assist in selection of erosion control devices. The equation for computing LS is as follows:

$$LS = \left(\frac{l}{72.6}\right)^m \times \left(\frac{65.41 \times s^2}{s^2 + 10,000} + \frac{4.56 \times s}{\sqrt{s^2 + 10,000}} + 0.065\right) \quad (3)$$

where:

- LS = length/slope factor
- l = slope length (Ft)
- s = slope in (ft/ft)
- m = exponent dependent on slope
  - = 0.2 for  $s \leq 1\%$
  - = 0.3 for  $1\% \leq s \leq 3.5\%$
  - = 0.4 for  $3.5\% \leq s \leq 4.5\%$
  - = 0.5 for  $s \geq 4.5\%$

The graph in Figure 3.2 was developed to solve Equation (3) and is used as follows:

1. Locate slope gradient on the bottom.
2. Follow vertically to the correct slope length curve.
3. The corresponding LS value can be read from the left side.

The amount of erosion is very sensitive to the length and slope factors (e.g. cutting the slope length in half will cut the erosion by approximately one-third).

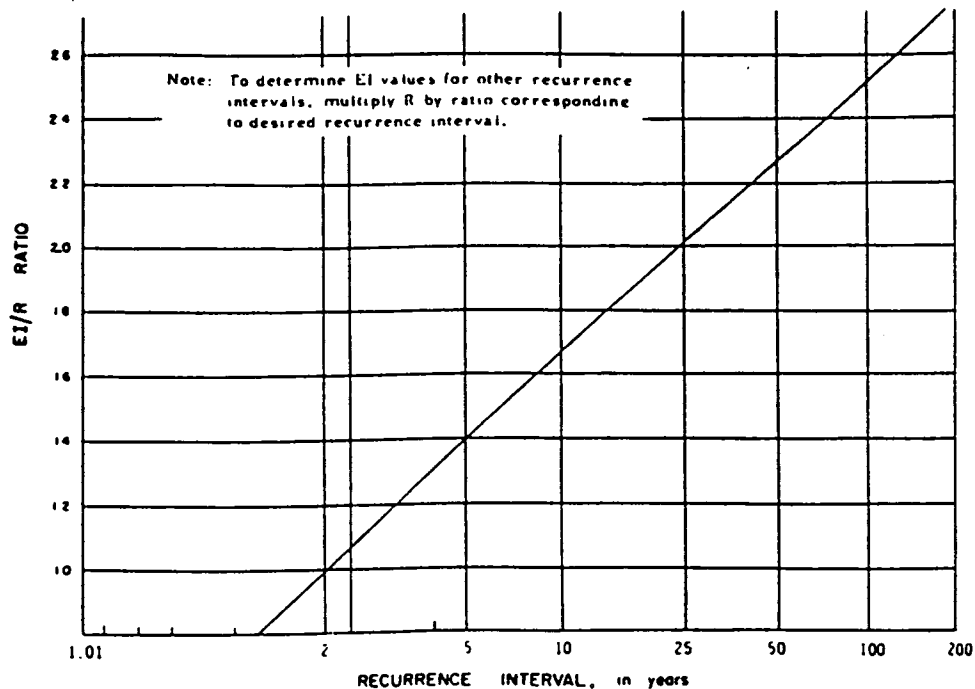
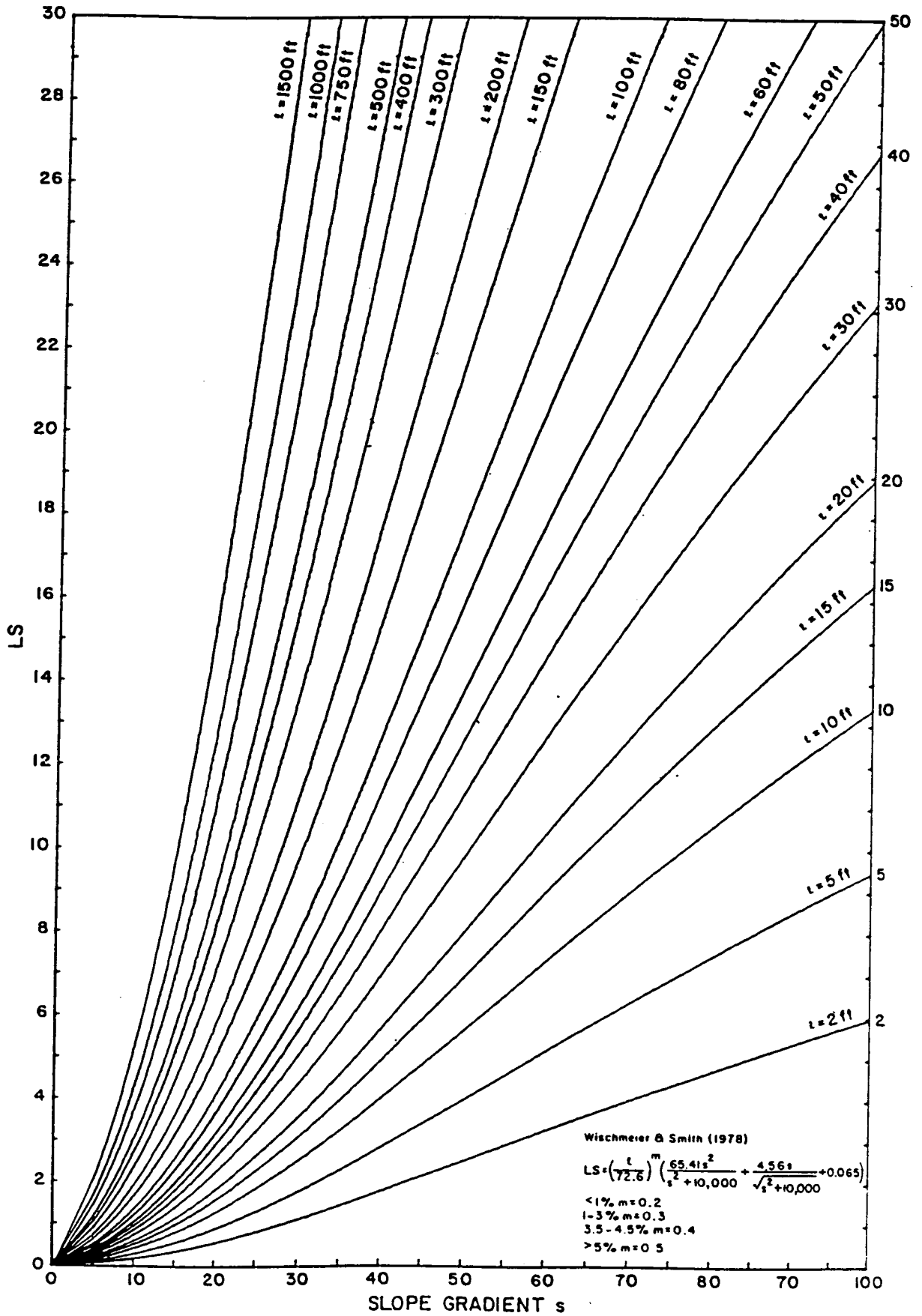

Figure 3.1 - Relationship between EI/R ratio and recurrence interval.



Figure 3.2 - Graphical Solution for Length Slope Factor



### Erosion Control Factor (VM)

The erosion control factor is applied to account for the effects of erosion control measures and devices used on a construction site. The lower the VM factor the more effective the device or control measure is in controlling erosion. Table 3.2 includes typical values based on the control device or measure utilized:

**Table 3.2 - Erosion Control Factors (VM) for various practices**

Vegetative Management Practice	VM Value
Bare Soil - freshly disked to 6-8 inches	1.00
Bare Soil - after one rain	0.89
Compacted Fill	1.24-1.71
Undisturbed soil - except for scraped	0.66-1.30
Soil Retention Blankets	0.015
Mulching (depends on application rate)	0.01-0.05
Hydromulch	0.05-0.10
Asphalt emulsion (depends on application rate)	0.01-0.57
Sediment Control Fence	0.25 *
Hay Bale	0.33 *
Triangular Sediment Dike	0.25 *
Inlet Protection	0.25-0.33 *
Sediment Trap - Stone Outlet	0.15-0.30 *
Sediment Basin	0.10 *
Sandbag Berm	0.30 *
Rock Filter Dam	0.30 *

\* The VM values for structural controls listed must be adjusted for the type of cover that lies within the watershed for which they are treating runoff. Table 3.3 indicates the correction factors to use depending on the percent grass and canopy cover.

$$VM = VM_{Practice} \times CoverFactor$$

(4)

## APPENDIX C

The cover factor considers the protection of natural ground cover in preventing soil erosion. The factor is dependent on the type of vegetation (grasses or trees) and the density of the vegetation. The canopy cover is the percent ground cover from the trees, brush or tall weeds. For construction sites stripped of natural vegetation, a cover factor of 1.0 should be used. Note: The table will produce a cover factor of 0.45 for an area with 0% canopy and 0% cover of grass. This value represents undisturbed bare soil. On construction sites the bare soils are typically disturbed and/or compacted or otherwise altered. A value of 1.0 is recommended in the areas for disturbed bare soil.

**Table 3.3 - Watershed Cover Factors**

Canopy Cover, %	Undisturbed Soil Percent Ground Cover of Grass				
	0	20	40	60	> 80
0	0.45	0.20	0.10	0.04	0.02
25	0.36	0.17	0.08	0.04	0.02
50	0.26	0.13	0.07	0.03	0.02
75	0.17	0.10	0.06	0.03	0.02

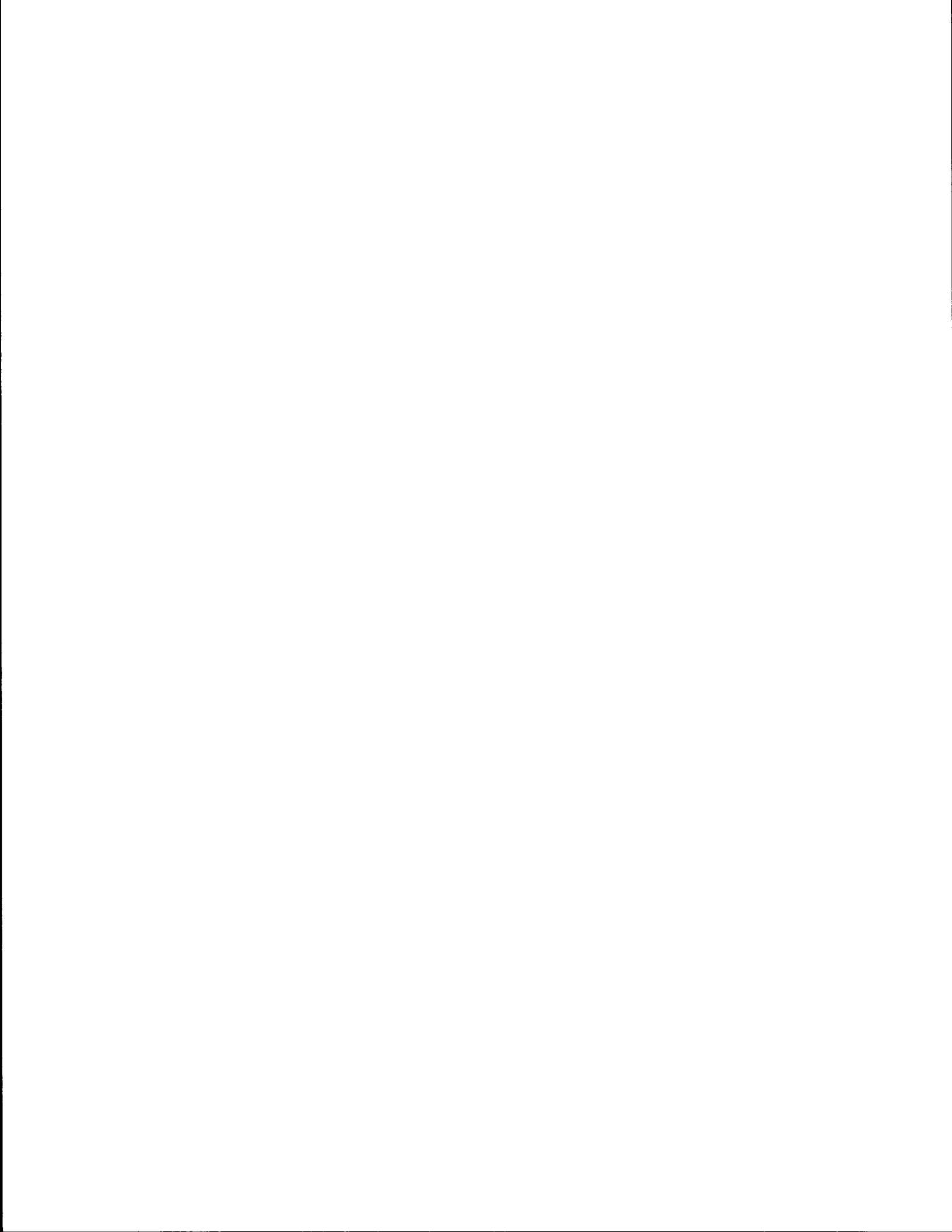

## **APPENDIX C**

### **SOIL CONSERVATION SERVICE TABLES**

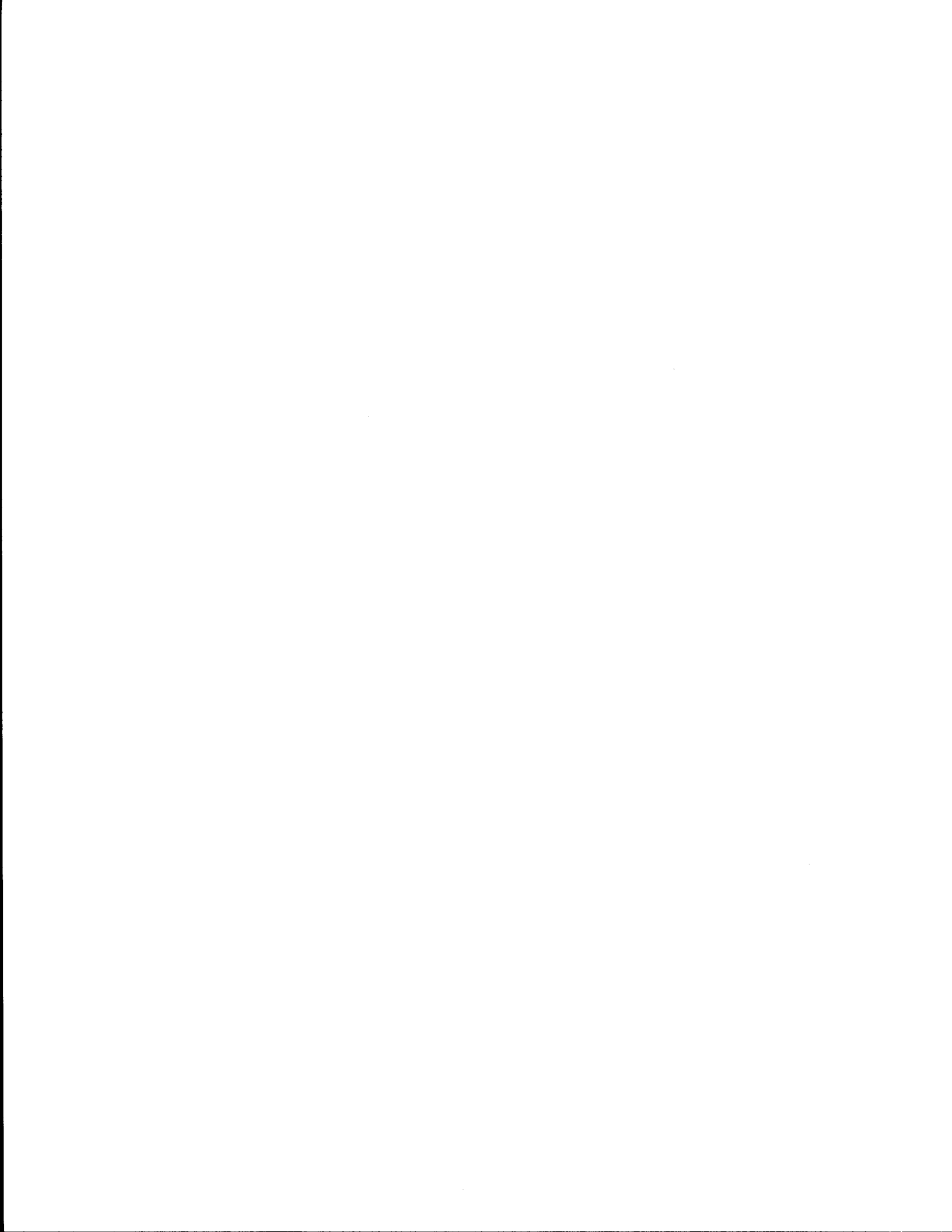
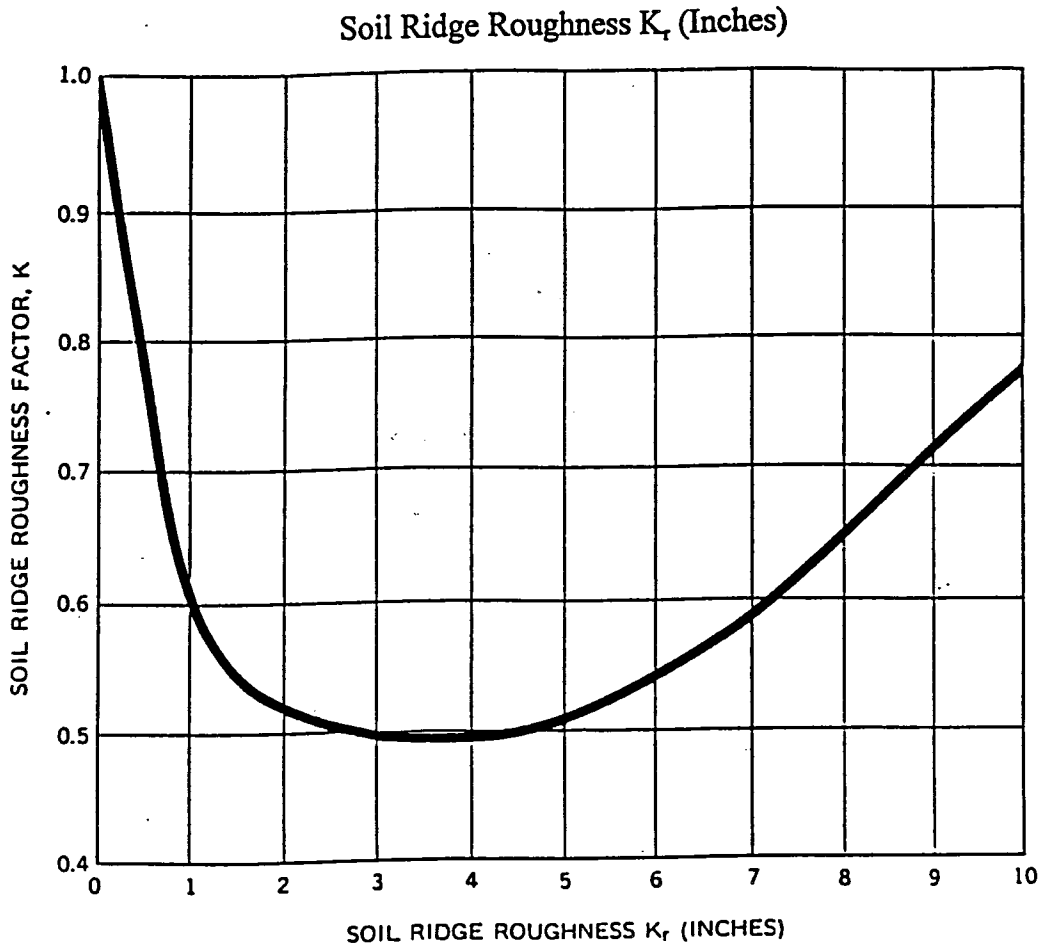

Table from the Soil Conservation Service, Erosion and Sediment Control Guidelines for Developing Areas in Texas, 1976. pp. 3-33.



$K_r$  is determined by the following equation:

$$K_r = \frac{\text{Standard ratio (1:4)}}{\text{Field measured ratio (1:X)}} \times \text{height of field ridges in inches}$$

Example: Ridge height = 3", distance between ridges = 18", then the ratio of ridge height to spacing is 3:18 or 1:6.

$$K_r = \frac{\text{Standard ratio (1:4)}}{\text{Field measured ratio (1:6)}} \times \text{height of field ridges (3")} = \frac{4}{6} \times 3" = 2 \text{ inches (ridged)}$$

FIGURE 3-8  
CHART TO DETERMINE SOIL RIDGE ROUGHNESS  
FACTOR (K) FROM SOIL RIDGE ROUGHNESS ( $K_r$ )





## APPENDIX D

### DETAILS OF EROSION AND SEDIMENT CONTROL MEASURES FROM LITERATURE REVIEW RESOURCES

- TxDOT Storm Water Guidelines for Construction Activities*, pp. 59-63
- Stormwater Management Manual for the Puget Sound Basin*, pp. 64-72
- Wisconsin DOT, Draft Manual*, pp. 73-75
- North Carolina Erosion and Sediment Control Planning and Design Manual*,  
pp. 76-86
- Erosion Draw CAD Software*, pp. 87-97



## 5.1 Diversion, Interceptor and Perimeter Dikes

### 1.0 Definition

A temporary ridge of compacted soil located either (1) immediately above cut or fill slopes, (2) across disturbed areas or rights-of-way or (3) along the perimeter of the site or disturbed areas.

### 2.0 Purpose

- A diversion dike intercepts runoff from small upland areas and diverts it away from exposed slopes to stabilized areas to prevent flow through disturbed areas.

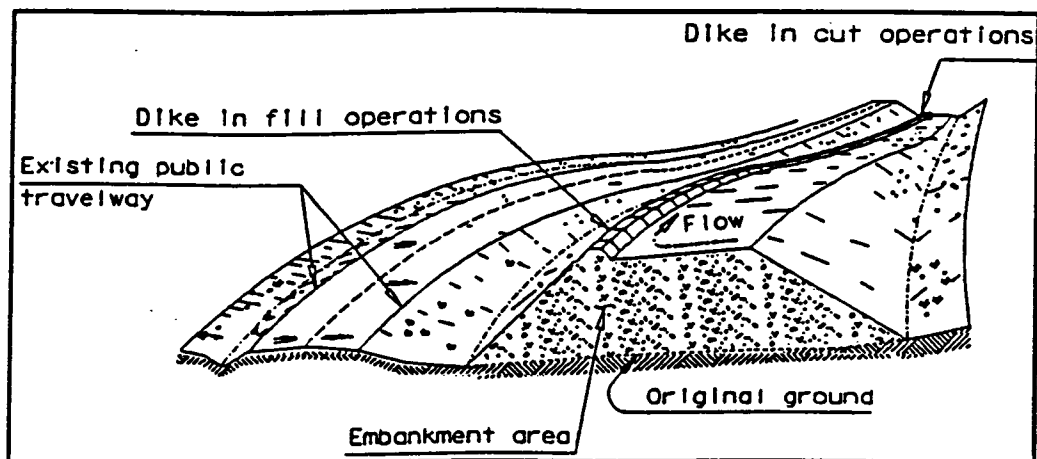
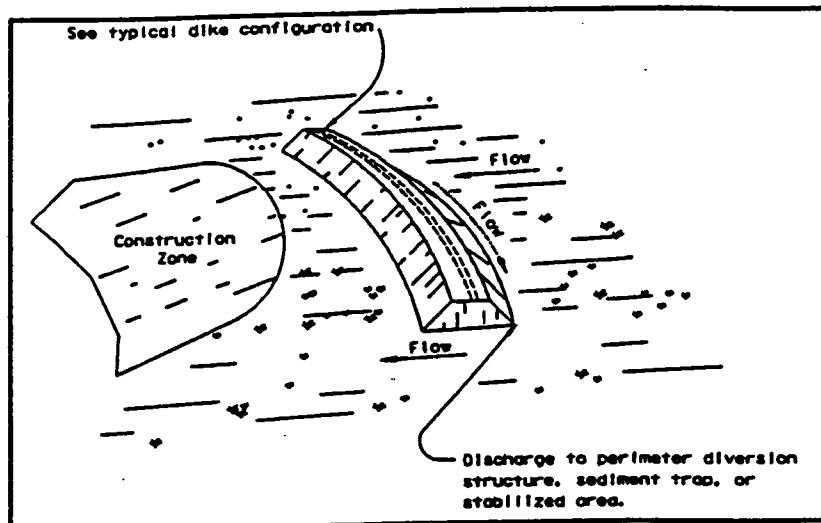

Figure 5.1 - Typical Diversion Dike installation

- An interceptor dike protects exposed slopes by intercepting runoff and diverting it to a stabilized outlet away from the exposed area.
- A perimeter dike prevents off-site runoff from entering the disturbed area and prevents sediment-laden storm runoff from leaving the construction site or disturbed area.
- A diversion or interceptor dike can be utilized to divert sediment-laden runoff to a stabilized outlet and minimize the need for other costly perimeter devices (e.g. silt fences).



**Figure 5.2 - Typical Interceptor Dike**

### 3.0 Conditions Where Practice Applies

Generally, dikes are used during the construction period to intercept and re-route runoff from disturbed areas to prevent excessive erosion until permanent drainage features are installed and/or slopes are stabilized. These devices can often result merely from the excavation and embankment construction activities. Therefore consideration to the earthwork requirements of a project may indicate the location for these devices.

### 4.0 Design Guidelines

The following guidelines should be considered:

- Drainage Area - Less than five (5) acres (recommended)
- Top Width - Two (2) feet minimum
- Height (compacted fill) - 18 inches minimum height measured from the top of the existing ground at the toe to top of the dike.
- Side Slopes - 2:1 or flatter. Dikes within the safety zone should have side slopes of 6:1 or flatter.
- Stabilization - Channel stabilization should be provided when erosive velocities are expected. The dikes themselves should be stabilized.
- Drainage diversions should not be directed to adjacent property.

## 5.4 Rock Filter Dam

### 1.0 Description

A temporary berm constructed of open-graded rock.

### 2.0 Purpose

The purpose of a rock filter dam is to intercept and slow down sediment-laden storm water runoff from disturbed areas, retain the sediment and release the water in sheet flow.

### 3.0 Conditions Where Practice Applies

- Where there is sheet flow or concentrated flow in a channel or other drainageway above the rock filter dam.

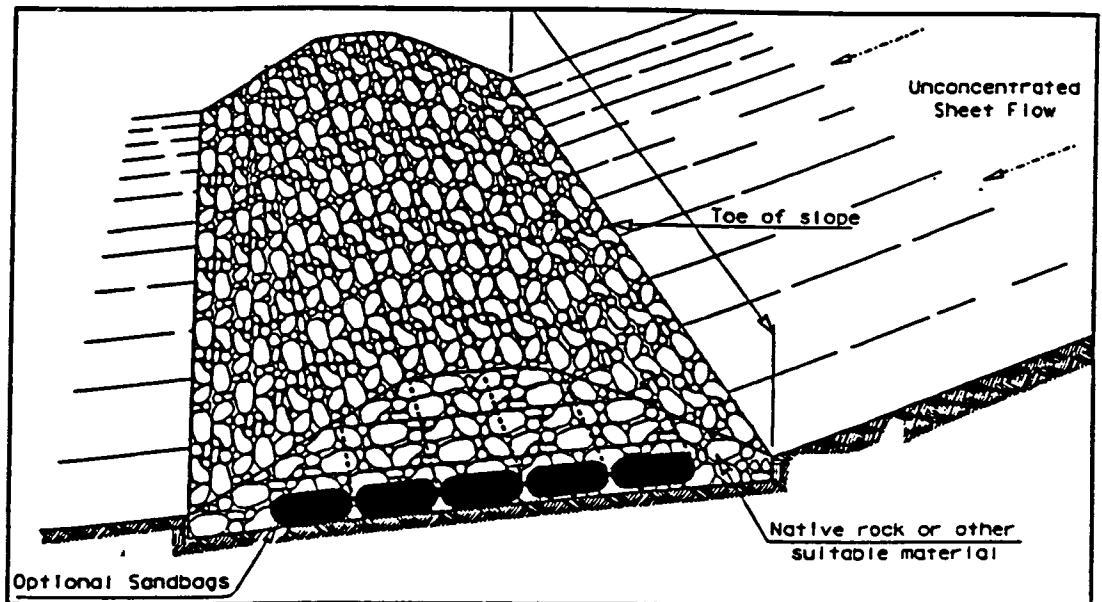

Figure 5.4 - Typical rock filter dam at toe of slope.

- Severe Service - For construction activities in stream beds where the contributing drainage area above the construction disturbance exceeds five (5) acres. In this case the rock filter dam is not to be used as a substitute for other measures further up in the watershed. It is to be used only where disturbance is occurring in the channel or where upslope measures are not feasible.
- Rock filter dams may also be used in conjunction with sediment control fences or sandbag berms to provide additional sediment removal.

Particular attention should be given to the locations of rock filter dams within the safety zone to avoid traffic hazards as well as to the sizing and placement to ensure that flooding will not occur.



**Figure 5.5 - Typical rock filter dam installed within channel - protected with wire cage.**

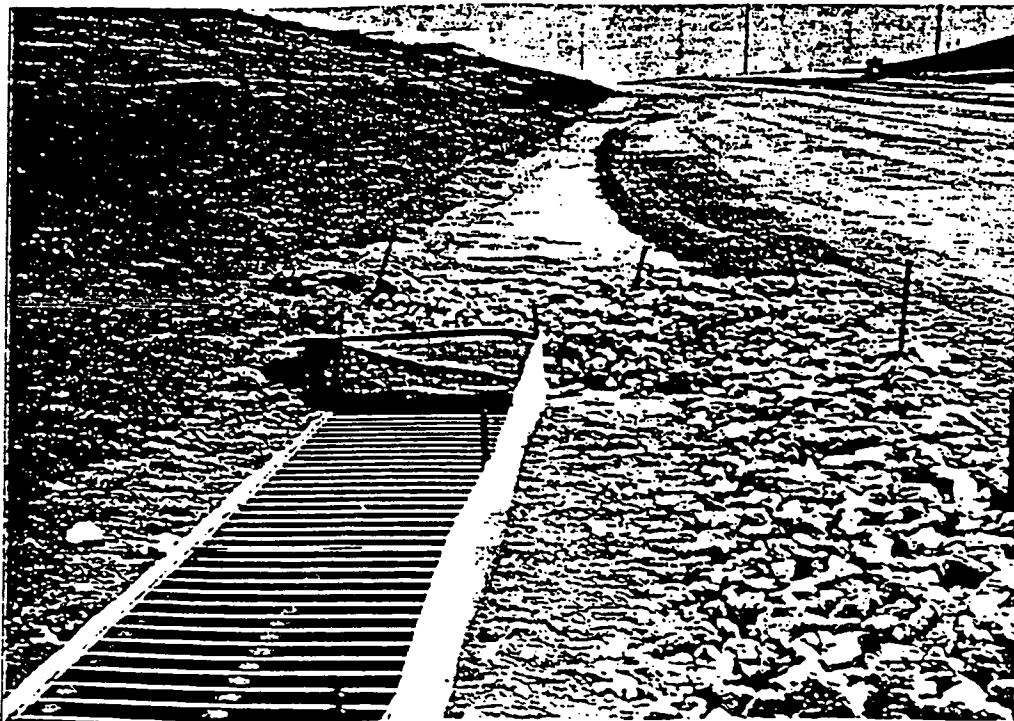

**Figure 5.6 - A rock filter dam used in conjunction with a sediment control fence as inlet protection.**

channelization. Care should be taken to avoid the incorporation of annual weeds and soil into the brush berm.

#### 5.0 Outlet

Runoff should outfall directly to an undisturbed or stabilized area.

#### 6.0 Maintenance

The area upstream of the brush berm should be maintained in a condition which will allow accumulated silt to be removed following the runoff of a rainfall event. Weekly, or after each rainfall event, inspections should be made by the responsible party and when silt reaches a depth equal to  $1/3$  the height of the berm or one (1) foot, whichever is less, the accumulated silt should be removed and disposed of at an approved site in a manner that will not contribute to additional siltation. The berm and its anchors should be repaired as needed to restore it to its original condition after each inspection. This may require additions or complete replacement as conditions warrant. The brush berm should be left in place until all upstream areas are stabilized and accumulated silt is removed.



Figure 5.8 - Typical brush berm constructed from material cleared on the site.

### 3.0 Conditions Where Practice Applies

A stabilized construction exit applies to all points of construction egress.

### 4.0 Design Guidelines

The following design guidelines should be considered:

- Stone Size - If stone is used as the material, the stone size should be four (4) to eight (8) inch open-graded rock.

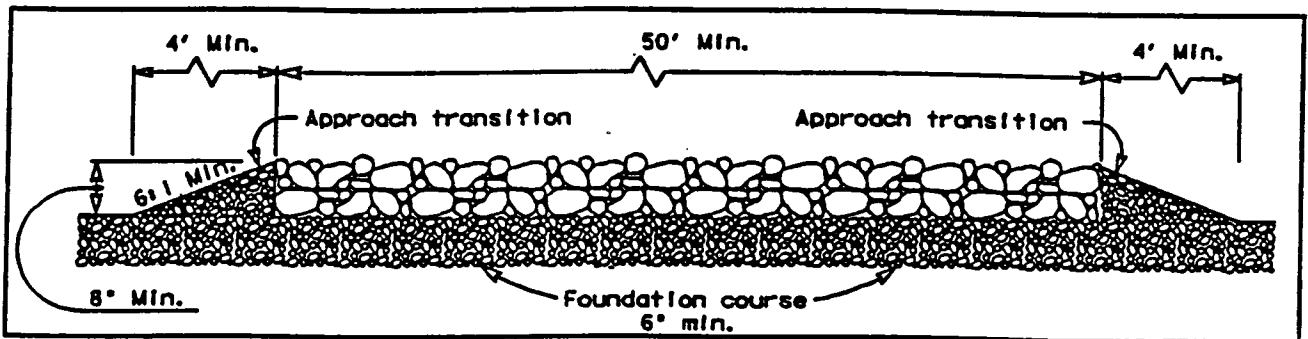

Figure 5.15 - Typical stone construction exit.

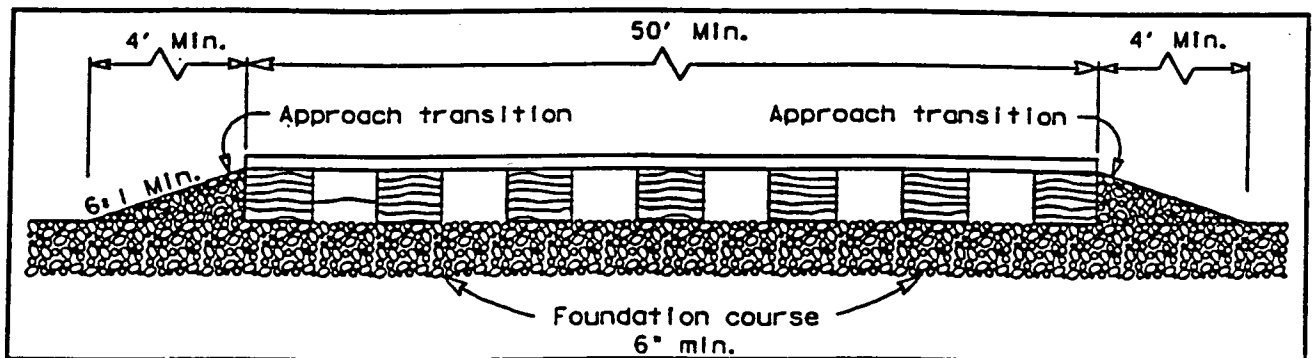

Figure 5.16 - Typical timber plank construction exit.

- Drainage - Exit must be properly graded or incorporate a drainage swale to prevent runoff from leaving the construction site.
- Thickness - Not less than eight (8) inches.
- Width - Not less than full width of all points of access.
- Length - As required, but not less than 50 feet.

A stabilized construction road should be installed in disturbed areas where there will be a high volume of construction traffic leaving the site. Preferably it should be maintained throughout the construction site, including parking areas. A stabilized construction road should not be located



Figure II-5.8(a) Heavy Equipment Can Be Used To Mechanically Scarify Slopes

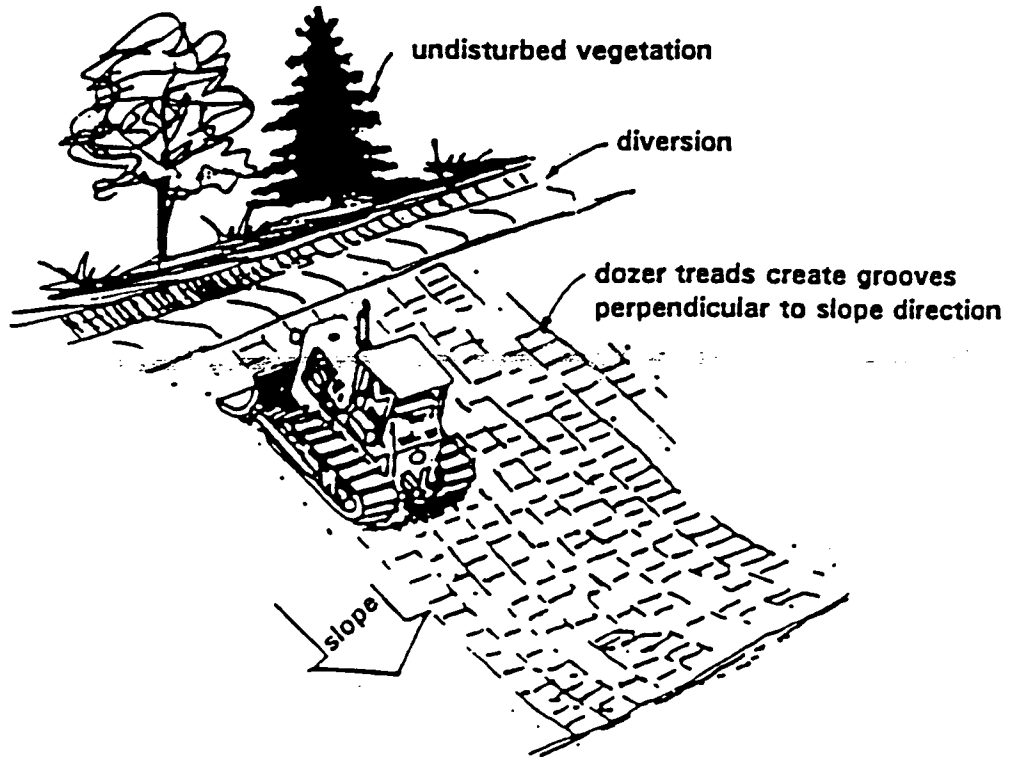
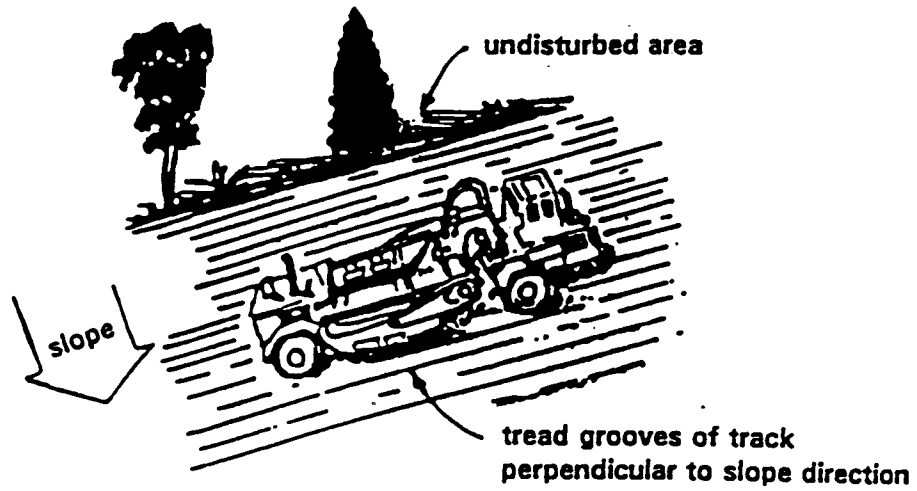

Figure II-5.8(b) Unvegetated Slopes Should be Temporarily Scarified to Minimize Runoff Velocities

Figure II-5.12 Level Spreader

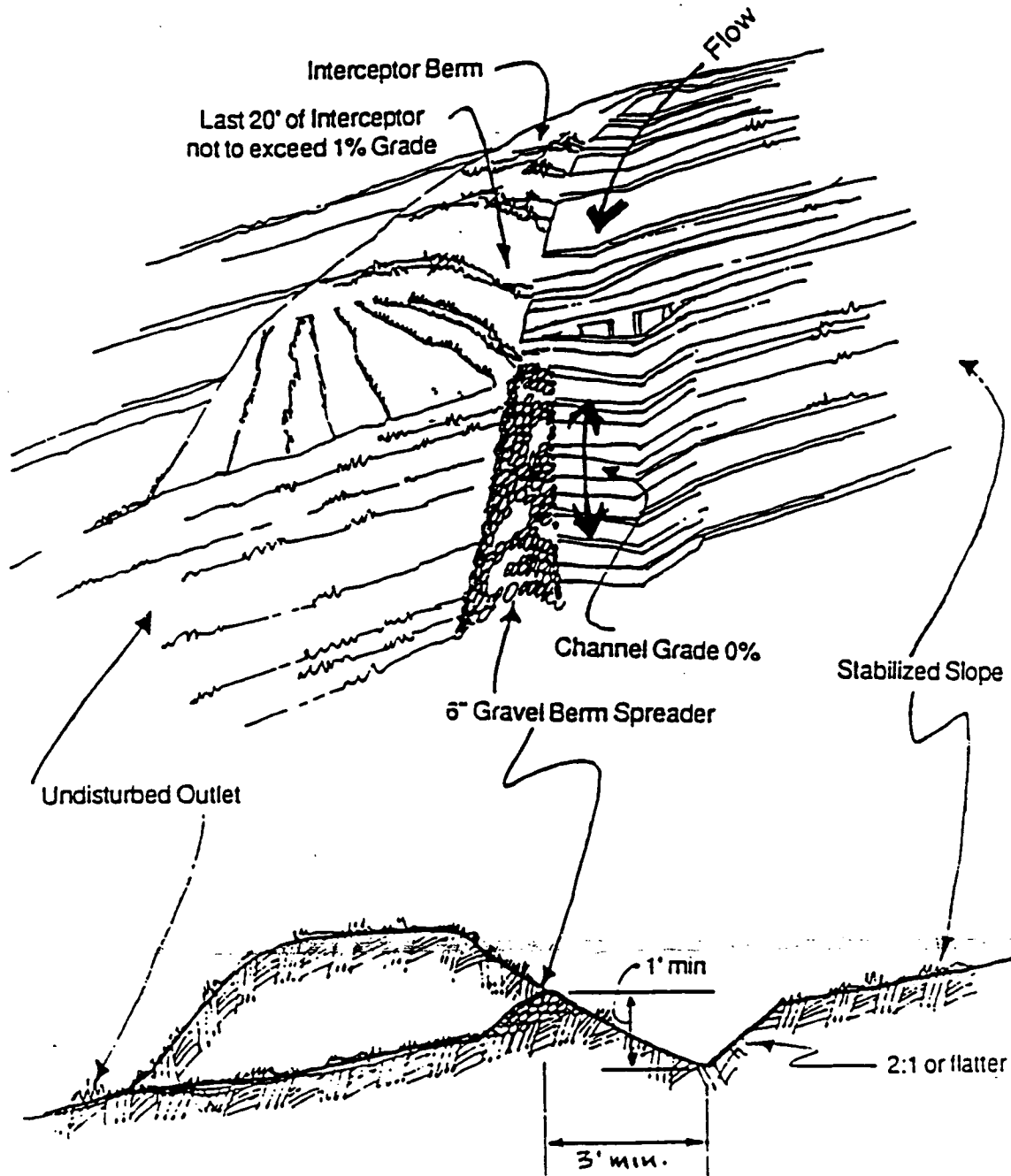

Figure II-5.4 Stabilized Construction Entrance

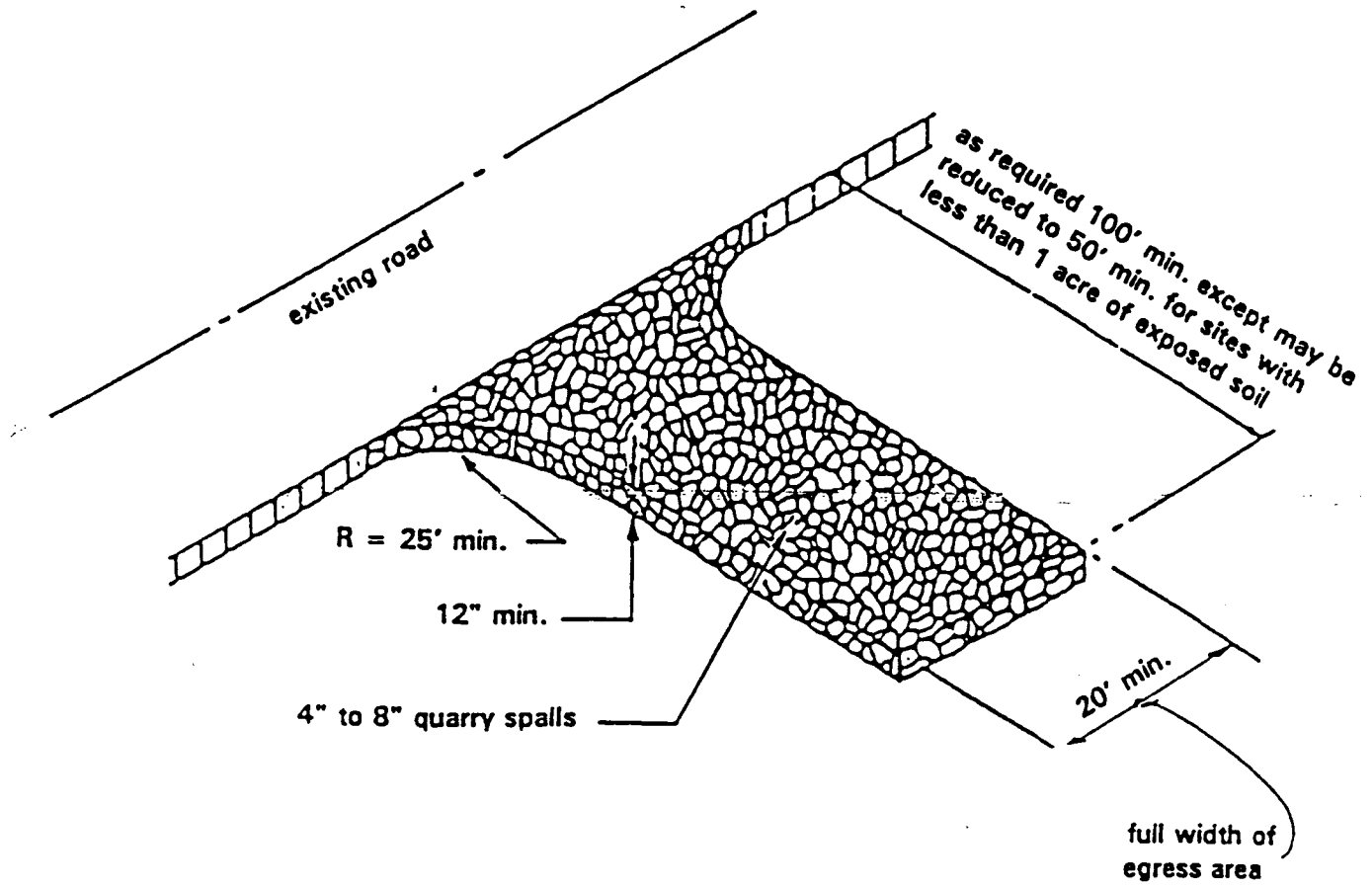

Figure II-5.5 Pipe Slope Drains

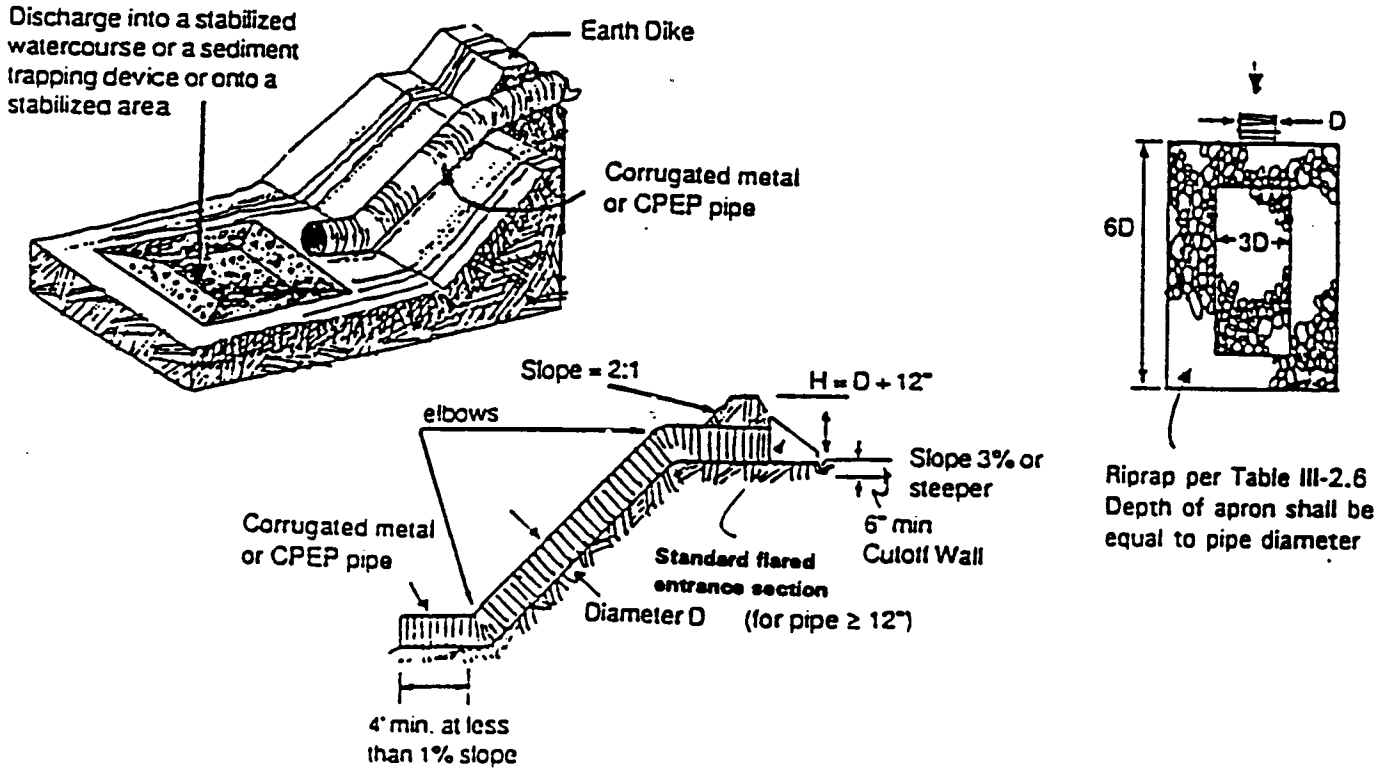
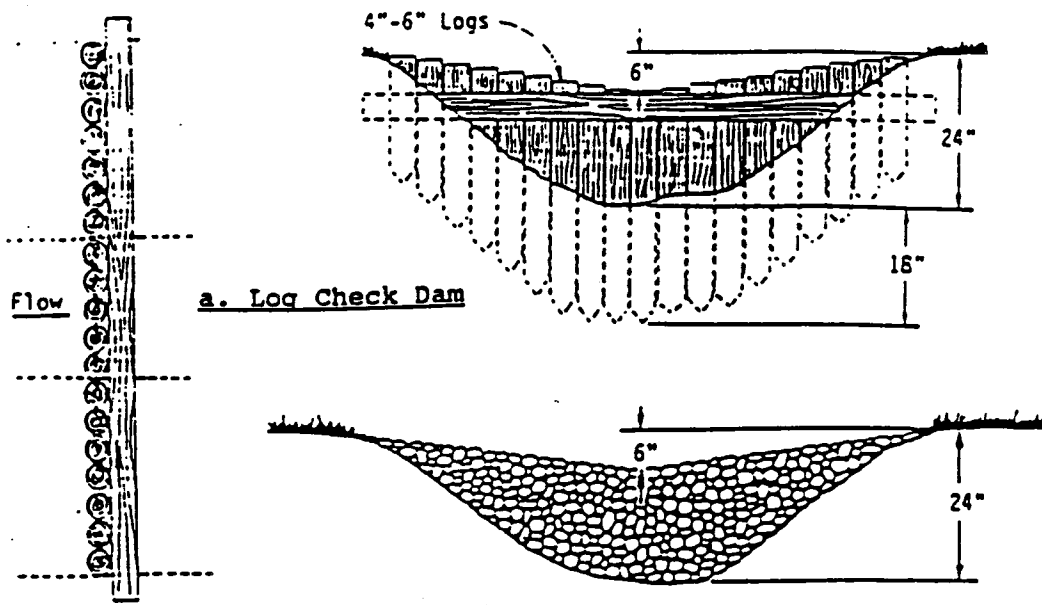
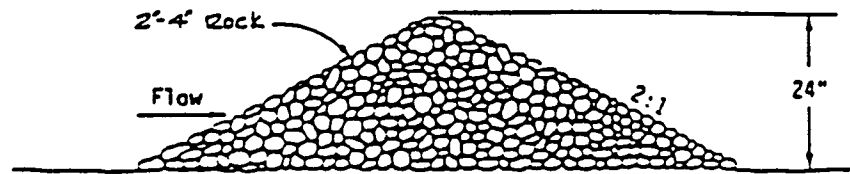

Figure II-5.14 Check Dams



NO SCALE



b. Rock Check Dam

NO SCALE

L = The distance such that points A & B are of equal elevation

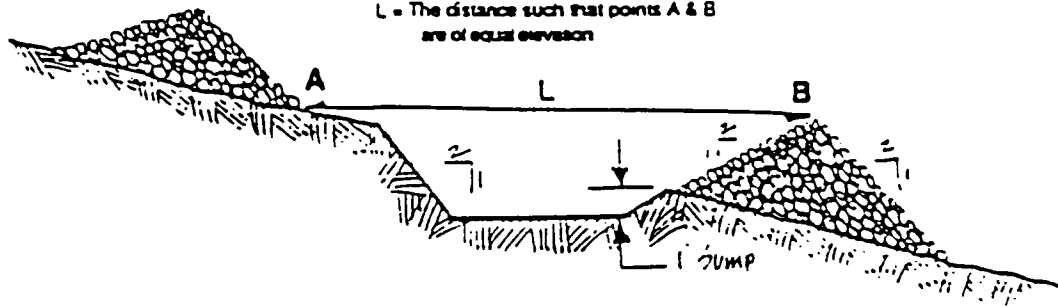

c. Spacing Between Check Dams

Figure II-5.20 Proper Installation of a Straw Bale Barrier

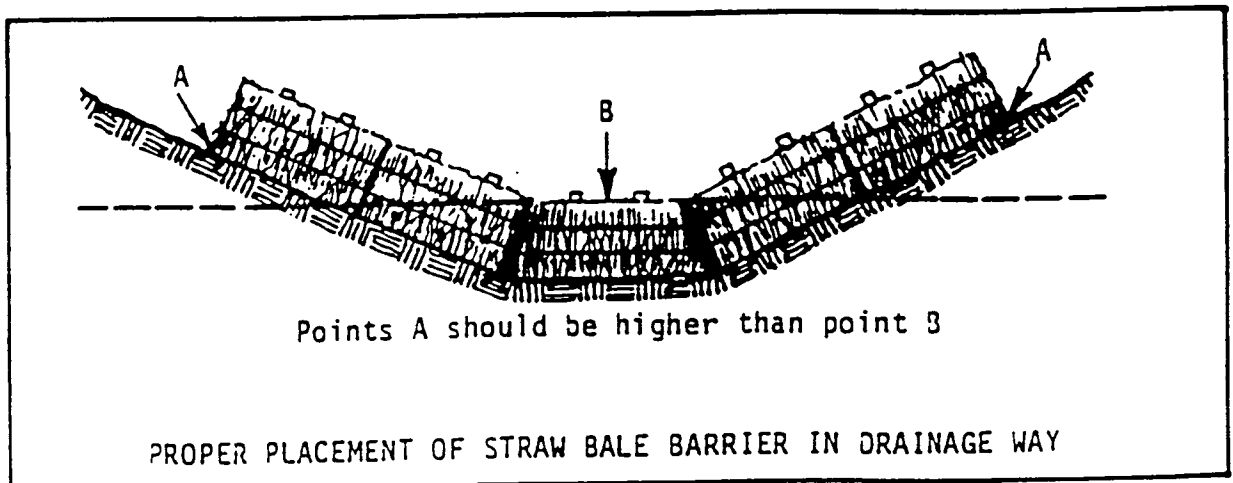
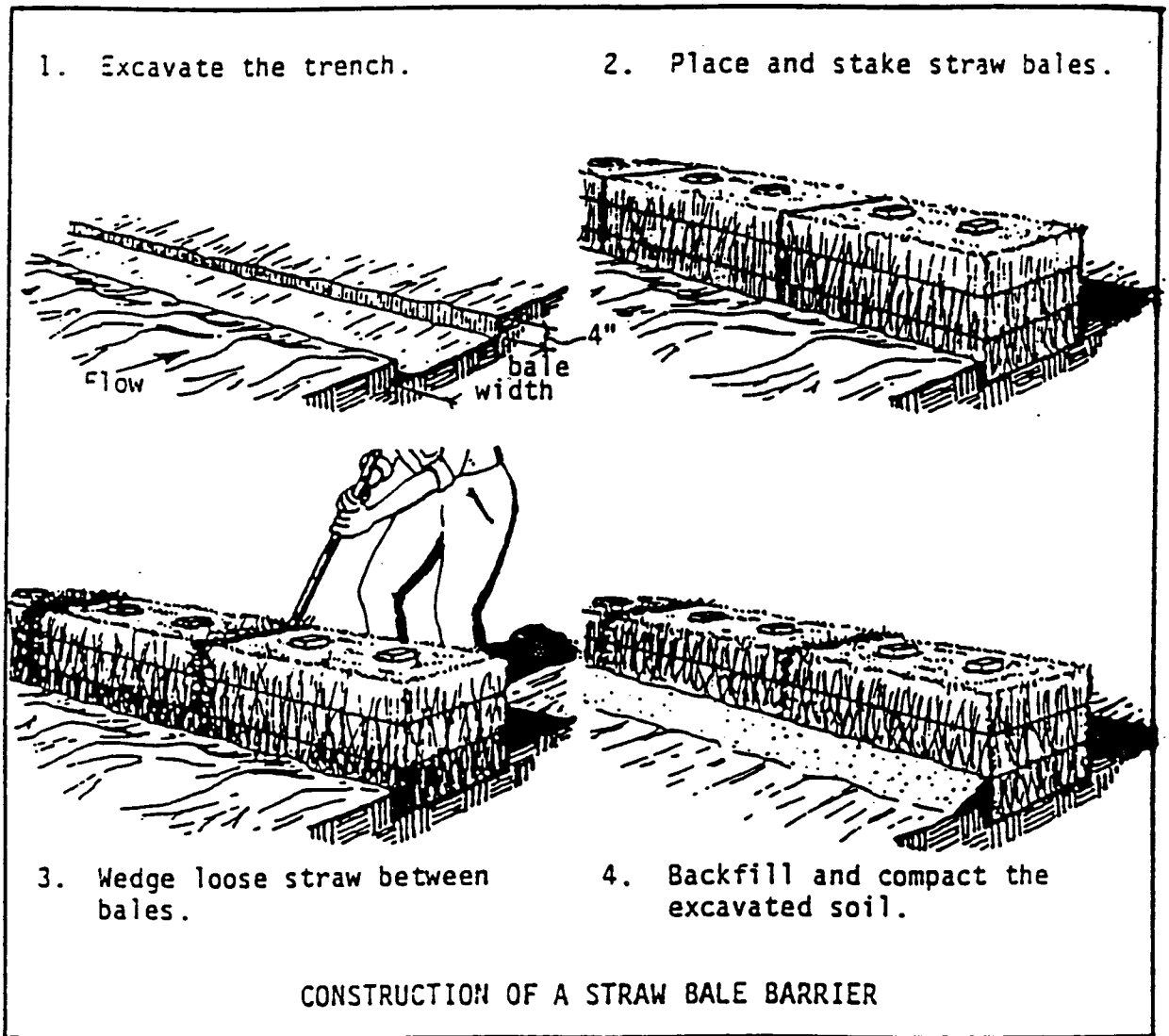

Figure II-5.21 Brush Barrier

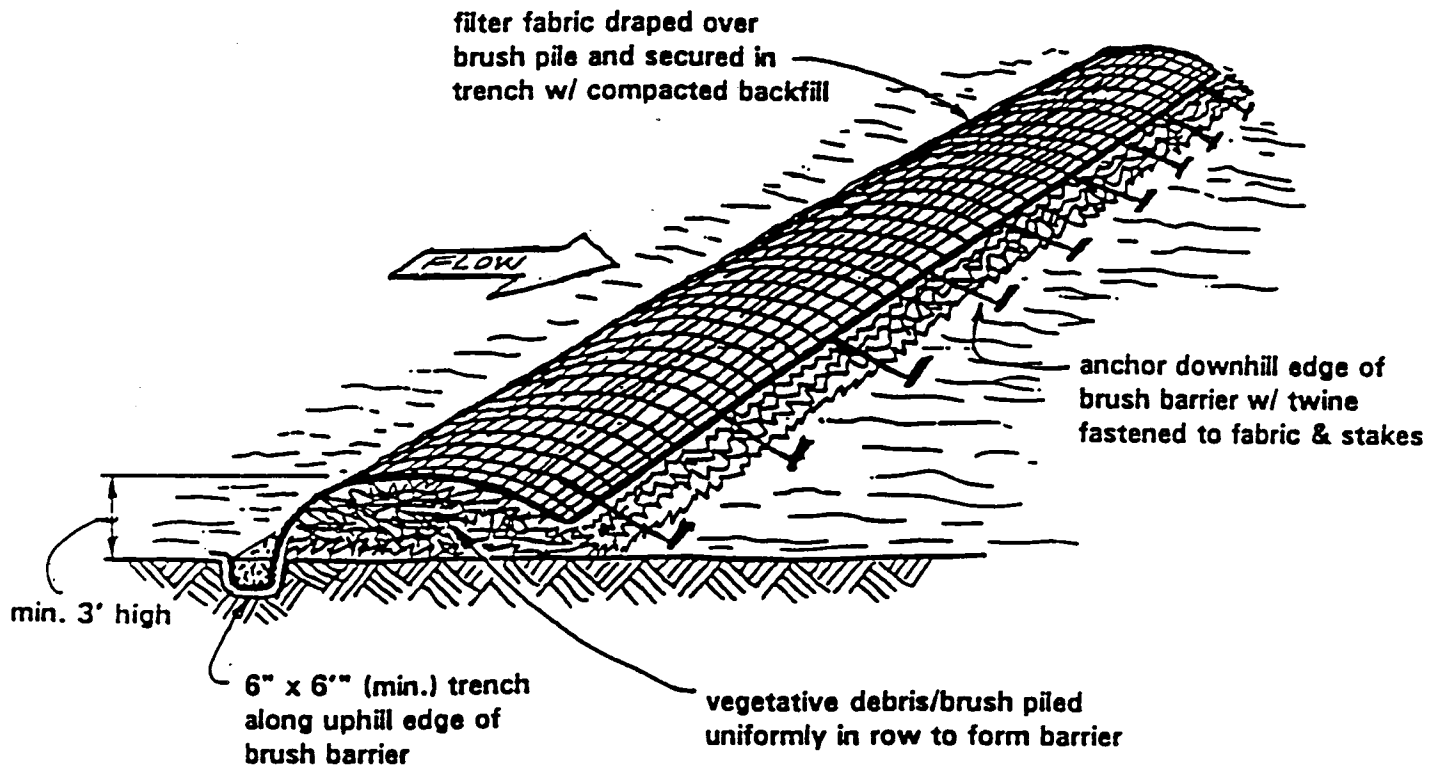

Figure II-5.28 Sediment Trap

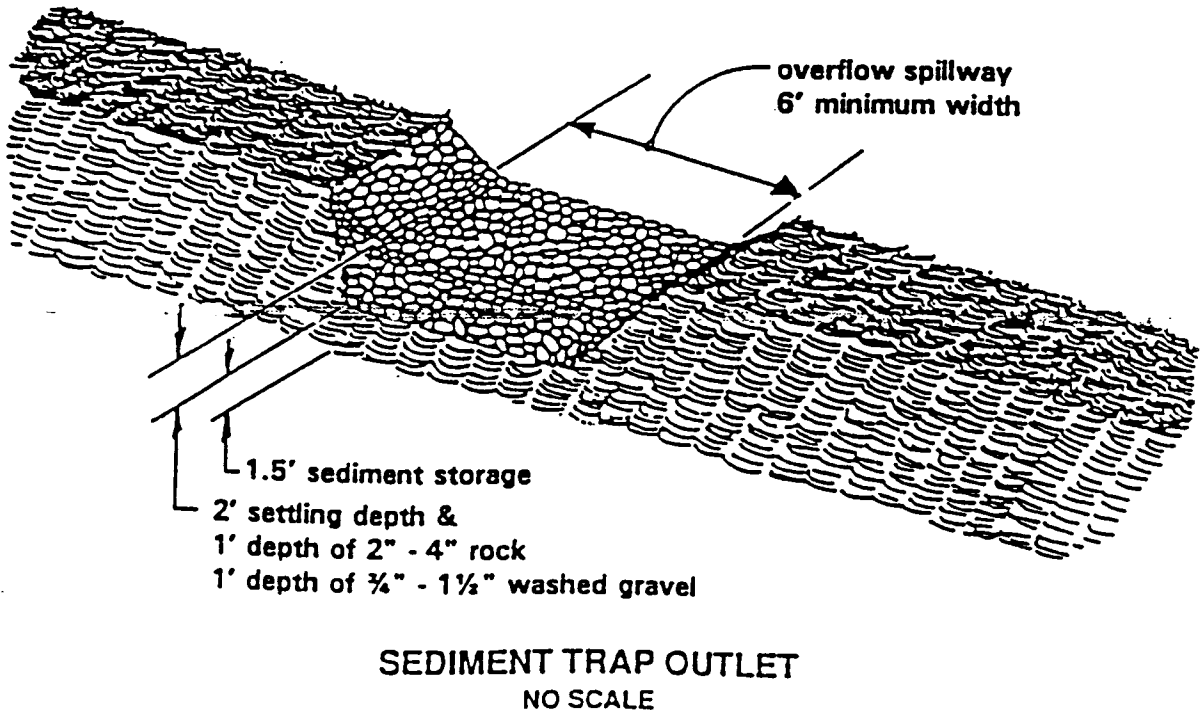
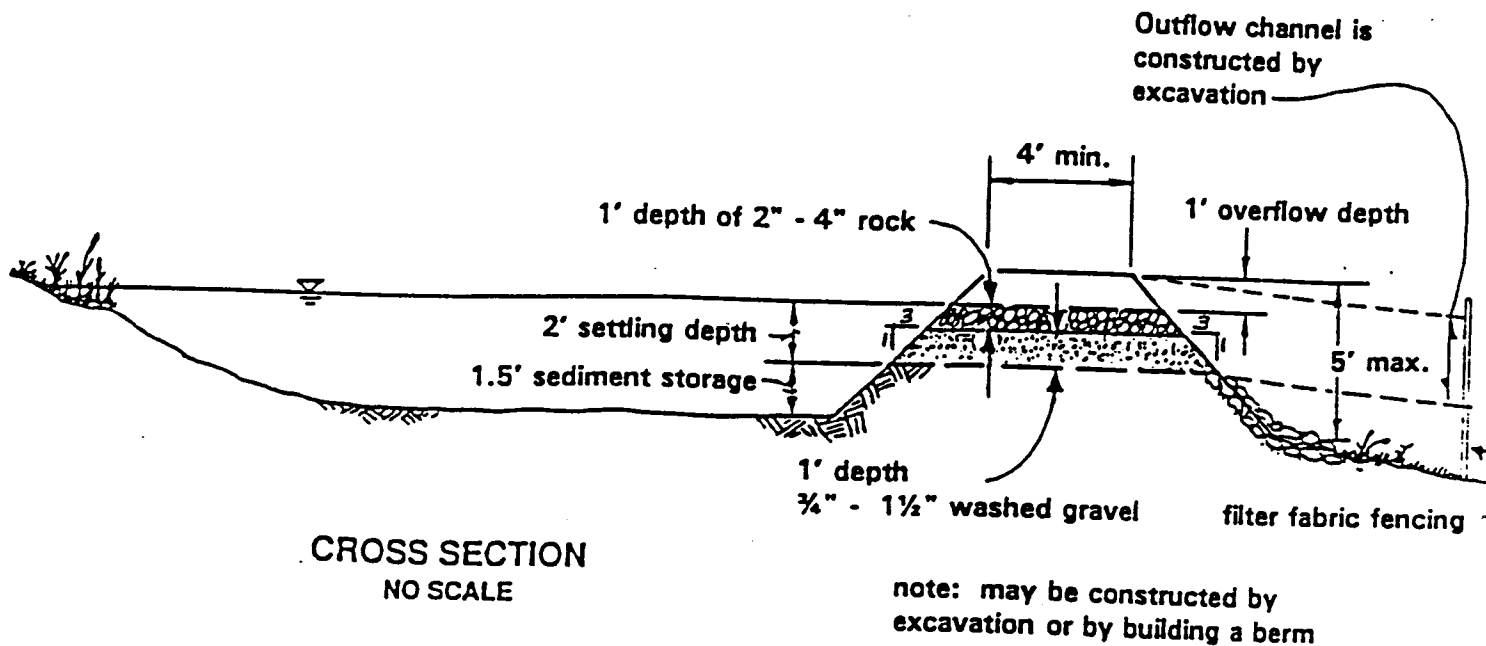
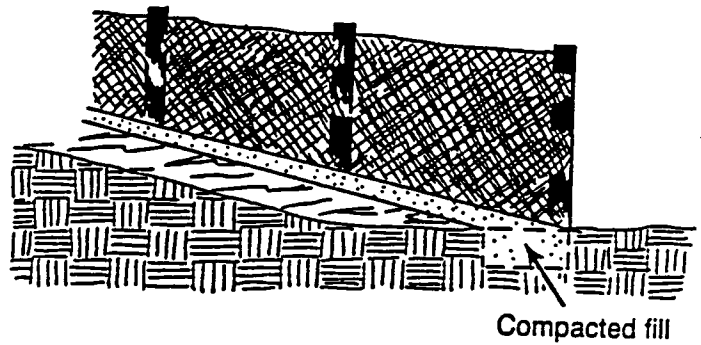
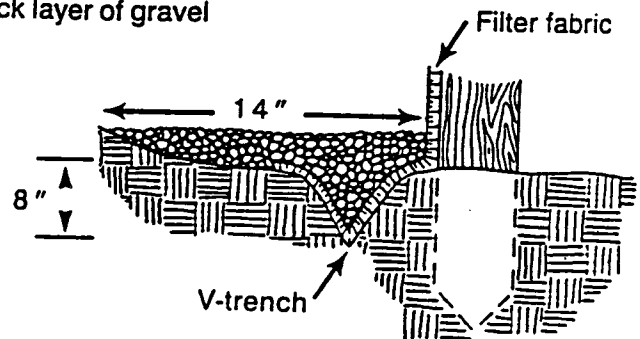



Figure 6.62a Installation detail of a sediment fence.



Backfill min 8" thick layer of gravel



Extension of fabric and wire into the trench

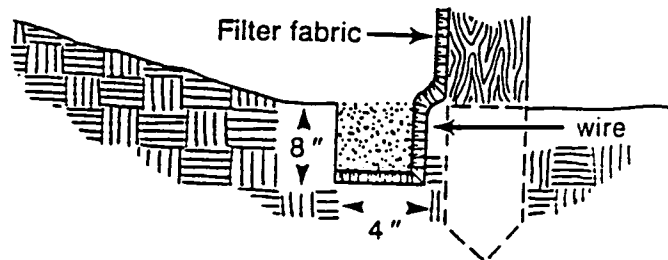

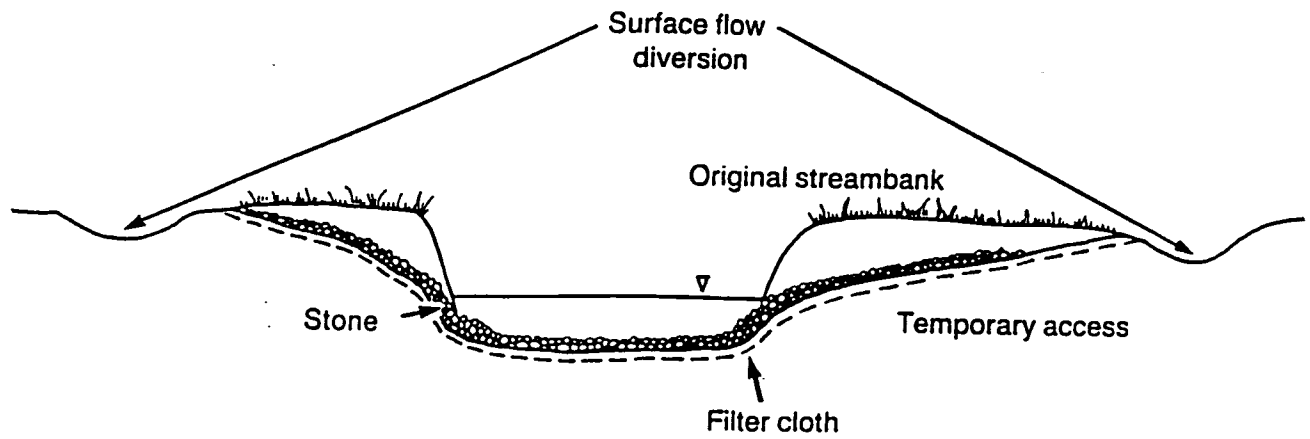
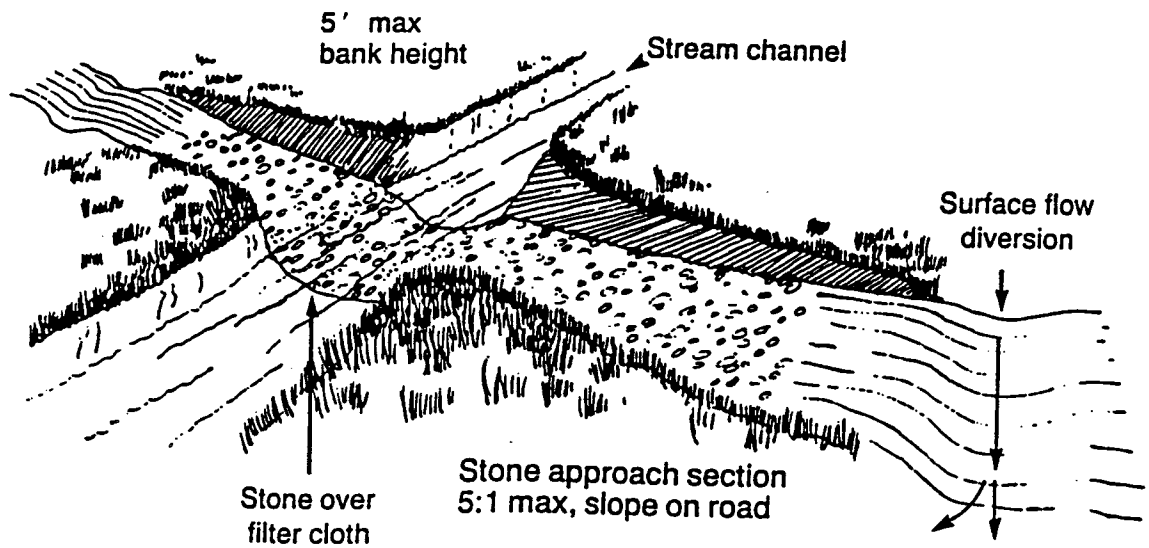

Figure 6.70a A well constructed ford offers little obstruction to flow while safely handling heavy loadings.

**Table 6.60a**  
**Design of Spillways**

Drainage Area (acres)	Weir Length <sup>1</sup> (ft)
1	4.0
2	6.0
3	8.0
4	10.0
5	12.0

<sup>1</sup>Dimensions shown are minimum

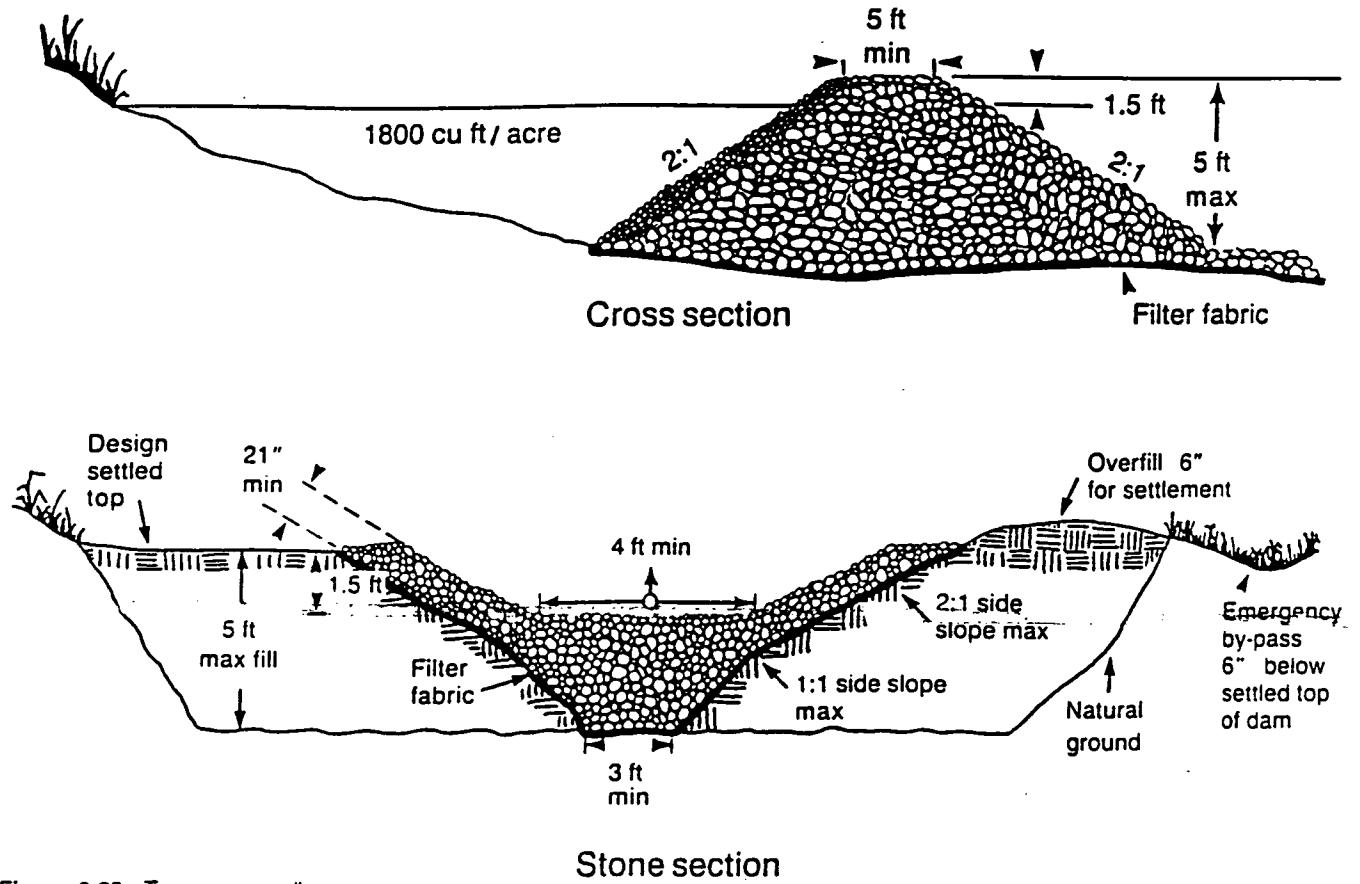
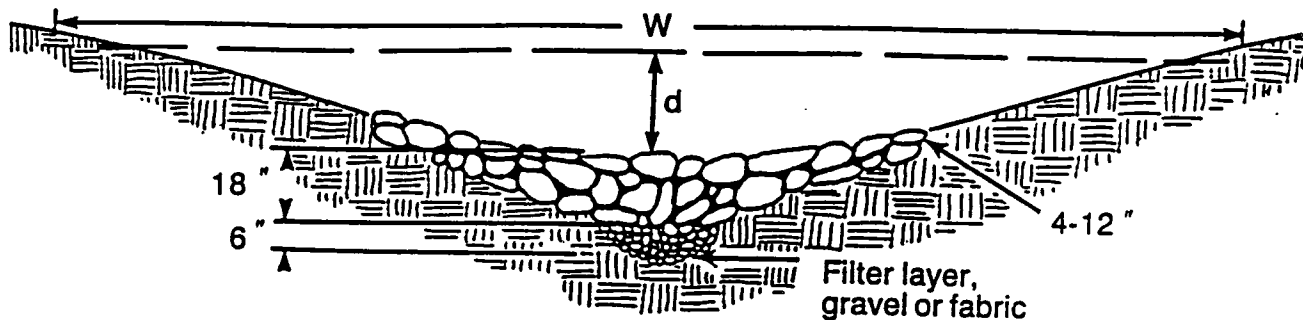
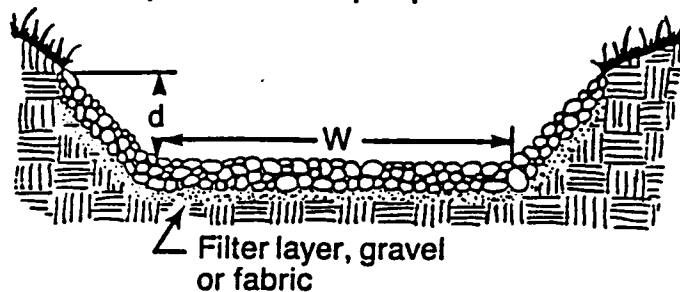

Figure 6.60a Temporary sediment trap.

### Vegetated V-shaped Waterway with Stone Center Drain



### Trapezoidal Riprap Channel



### Vegetated Parabolic-shaped Waterway with Stone Center Drain

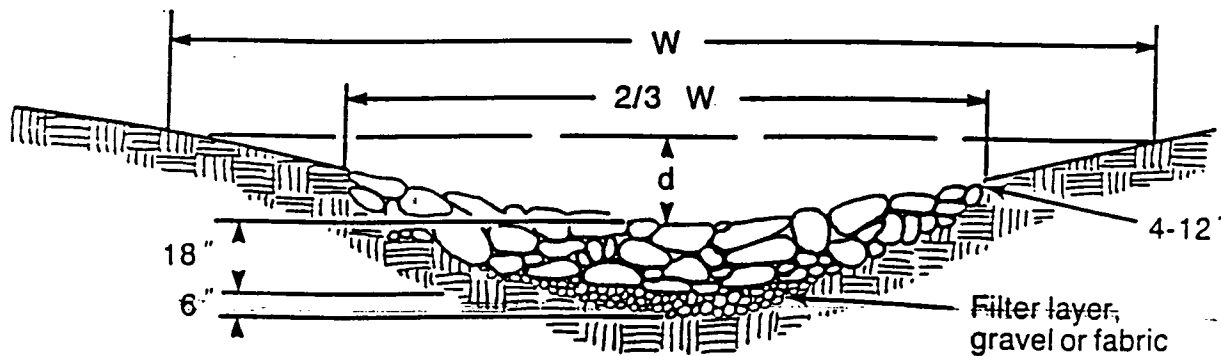
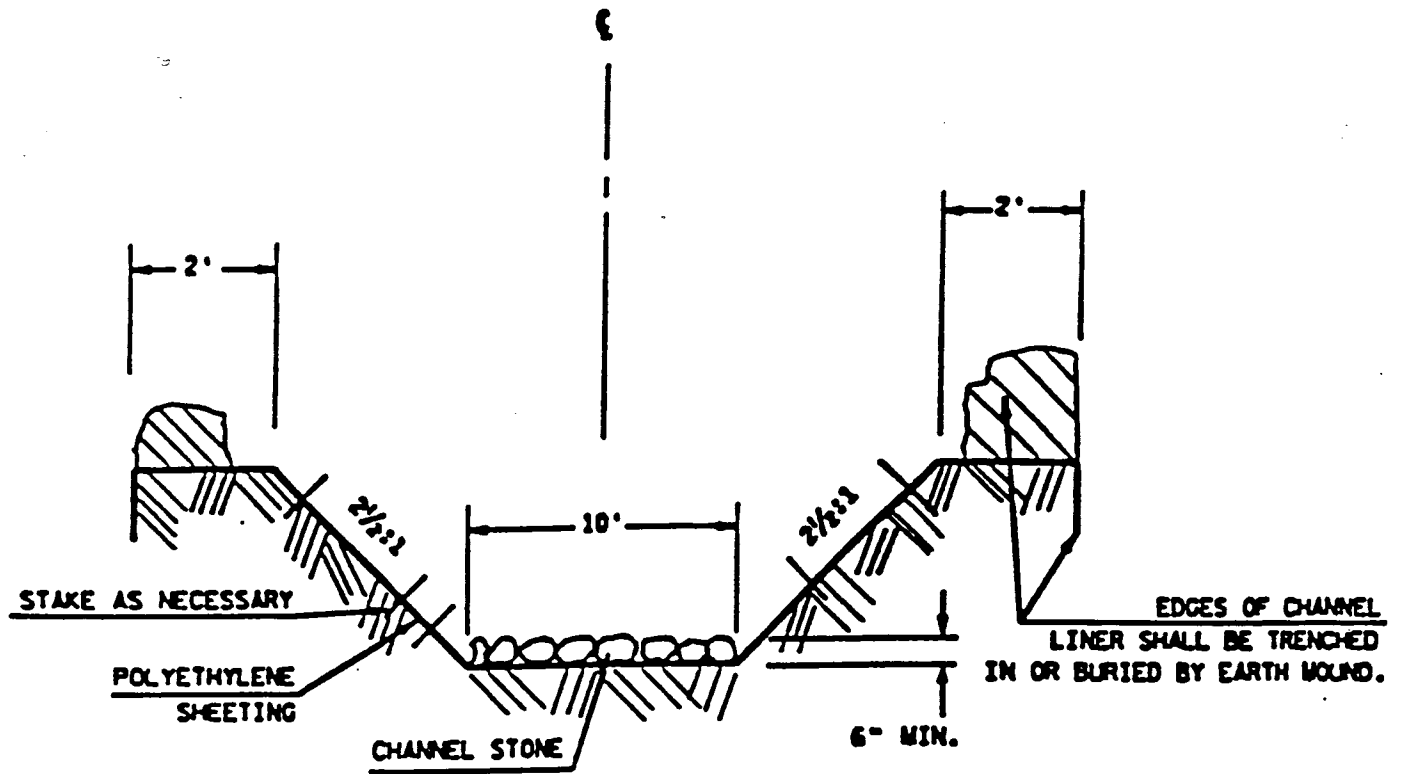
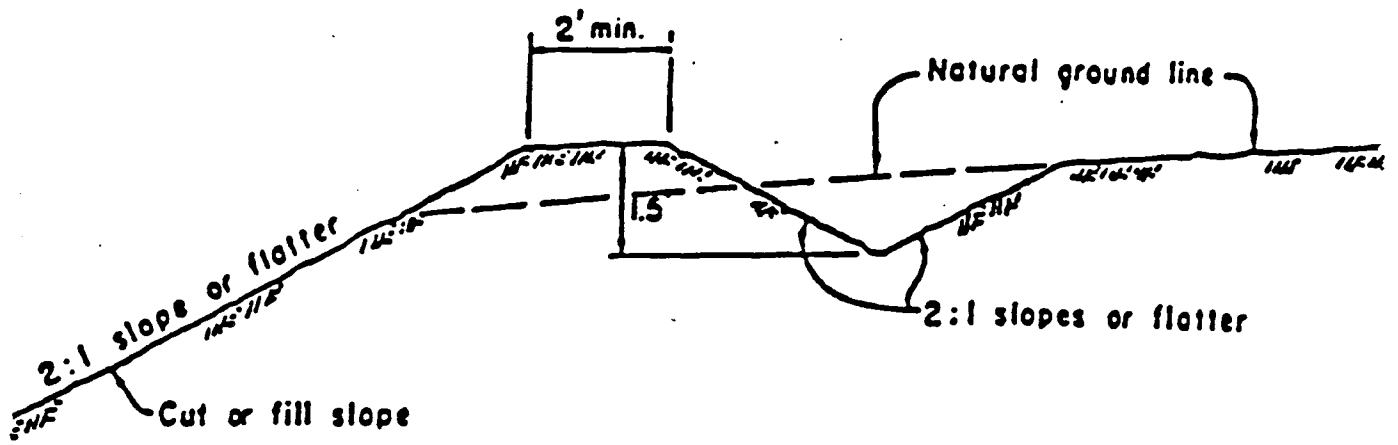

Figure 6.31a Construction detail of riprap channel cross sections.



**TYPICAL SECTION OF  
TEMPORARY CHANNEL CHANGE**



**SECTION**  
not to scale

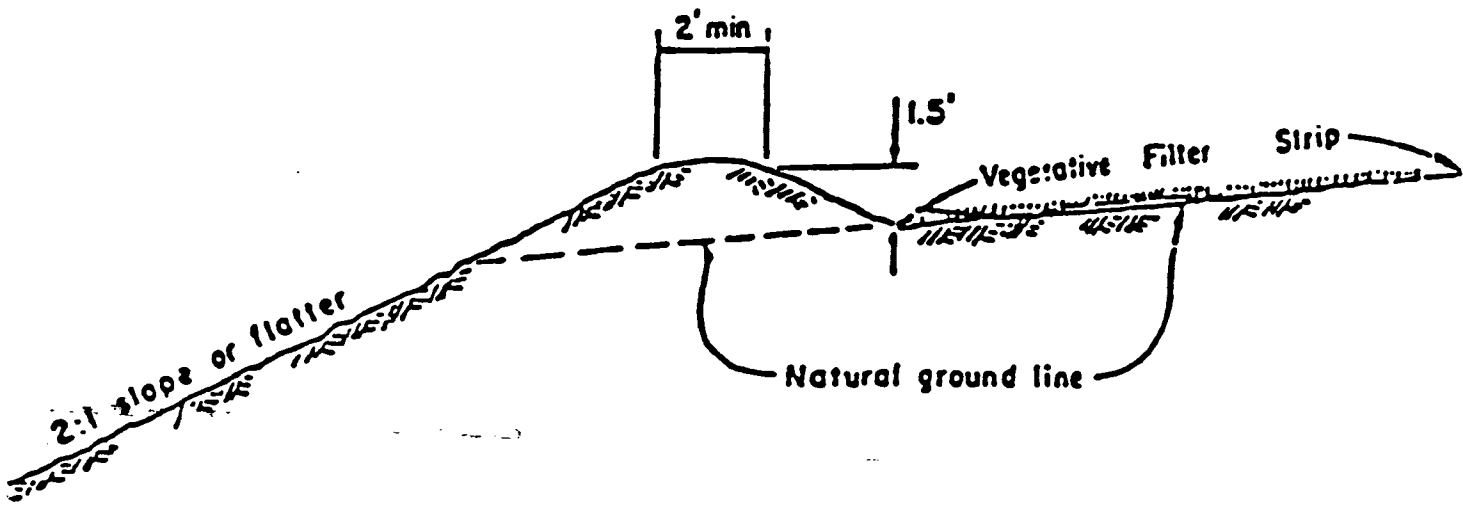

**SECTION**

Dike constructed by dozer moving soil upslope and dumping at top of slope.

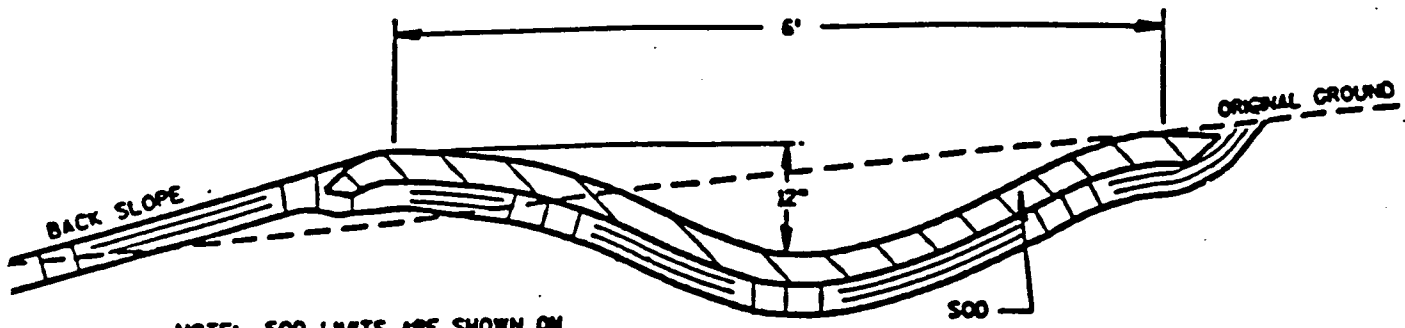

NOTE: SOD LIMITS ARE SHOWN ON MISCELLANEOUS QUANTITIES SHEET

**DETAIL OF SOD DITCH ON INTERCEPTING EMBANKMENT**

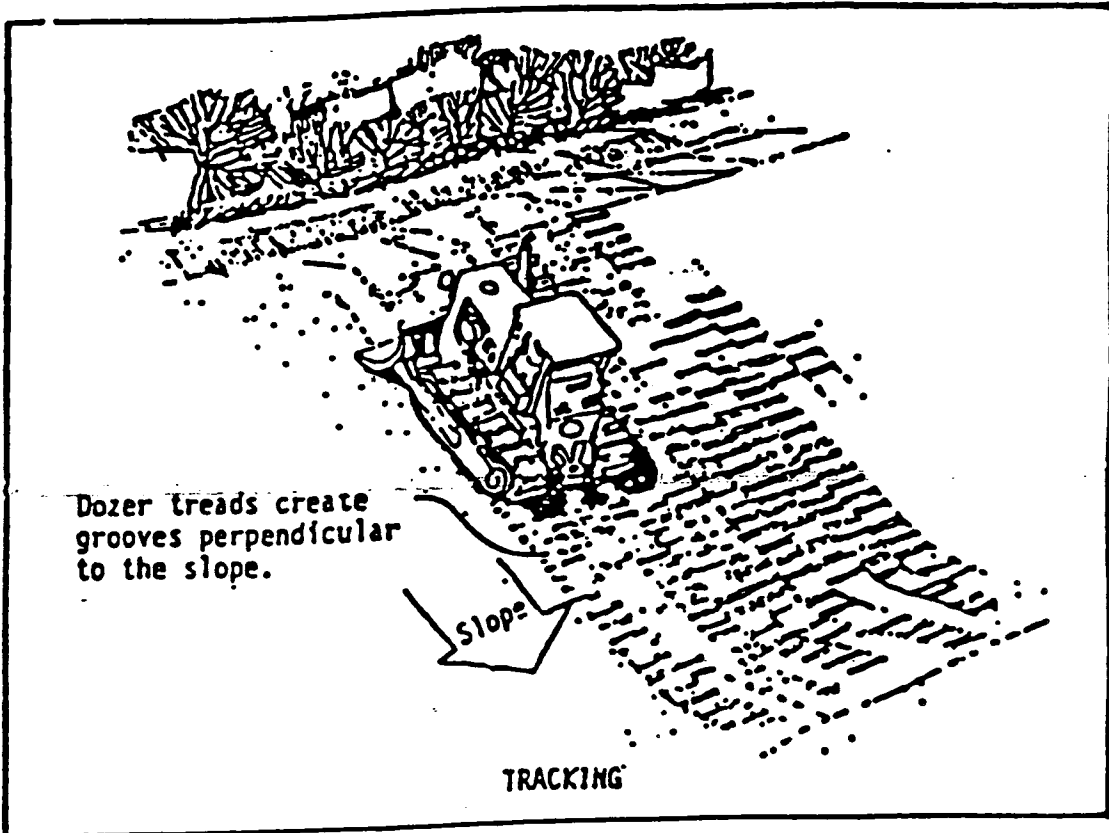
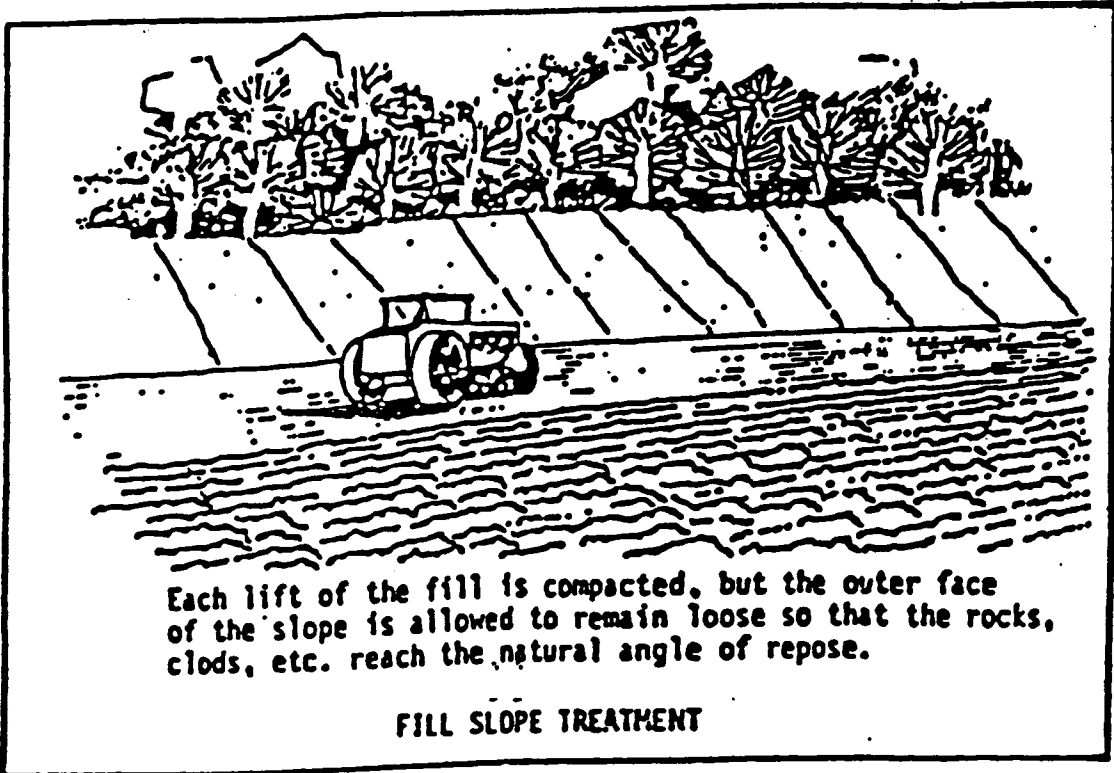





Consider structural measures for streambank stabilization where it is evident that vegetative stabilization will be inadequate. Channel reaches are often made stable by establishing vegetation where erosion potential is low and installing structural measures where the attack is more severe, such as the outside of channel bends and where the natural grade steepens.

Riprap is the most common structural method used, but other methods such as gabions, deflectors, reinforced concrete, log cribbing, and grid pavers should be considered, depending on site conditions.



Structural streambank stabilization such as gabions and riprap is necessary where stream velocities are high and side slopes are steep.

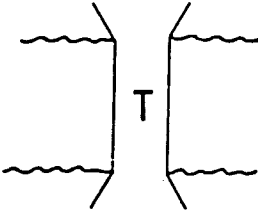

Stream crossings are direct sources of water pollution. They cause flooding and safety hazards and can be expensive to construct. If washed out or damaged, they can also cause costly construction delays. Plan the development to complete work on each side separately to minimize stream crossings.

Stream crossings are of three general types: bridges, culverts, and fords. In selecting a stream crossing practice consider: frequency and kind of use, stream channel conditions, overflow areas, potential flood damage, surface runoff control, safety requirements and installation and maintenance costs. Temporary crossings may overflow during peak storm periods, however, the structure and approaches must remain stable.



Temporary stream crossing may be a ford, culvert or bridge. Bridges allow full stream flow but must be designed and built to support expected loads.

→ TD →

**Definition** A temporary ridge or excavated channel or combination ridge and channel constructed across sloping land on a predetermined grade.

**Purpose** To protect work areas from upslope runoff and to divert sediment-laden water to appropriate traps or stable outlets.

**Conditions Where Practice Applies** This practice applies to construction areas where runoff can be diverted and disposed of properly to control erosion, sedimentation, or flood damage. Specific locations and conditions include:

- above disturbed existing slopes, and above cut or fill slopes to prevent runoff over the slope;
- across unprotected slopes, as slope breaks, to reduce slope length;
- below slopes to divert excess runoff to stabilized outlets;
- where needed to divert sediment-laden water to sediment traps;
- at or near the perimeter of the construction area to keep sediment from leaving the site;
- above disturbed areas before stabilization to prevent erosion and maintain acceptable working conditions.
- Temporary diversions may also serve as sediment traps when the site has been overexcavated on a flat grade; they may also be used in conjunction with a sediment fence.

### Planning Considerations

It is important that diversions are properly designed, constructed and maintained since they concentrate water flow and increase erosion potential (Figure 6.20a). Particular care must be taken in planning diversion grades. Too much slope can result in erosive velocity in the diversion channel or at the outlet. A change of slope from steeper grade to flatter may cause deposition to occur. The deposition reduces carrying capacity and may cause overtopping and failure. Frequent inspection and timely maintenance are essential to the proper functioning of diversions.

Sufficient area must be available to construct and properly maintain diversions. It is usually less costly to excavate a channel and form a ridge or dike on the

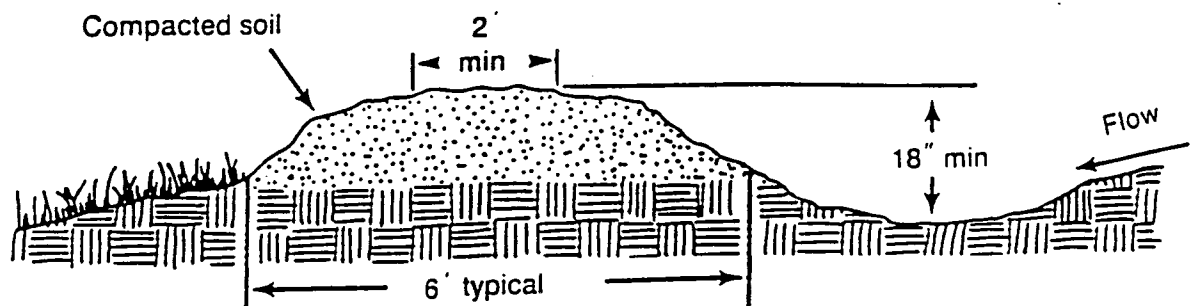

Figure 6.20a Temporary earthen diversion dike.  
Temporary Erosion Control Final Report

A synthetic filter fabric may be used with or in place of gravel filters. The following particle size relationships should exist:

- Filter fabric covering a base with granular particles containing 50% or less (by weight) of fine particles (less than U.S. Standard Sieve no. 200 (0.074mm)):

a.

$$\frac{d_{85} \text{ base (mm)}}{\text{EOS}^* \text{ filter fabric (mm)}} > 1$$

b. total open area of filter should not exceed 36%

- Filter fabric covering other soils:

a. EOS is no larger than U.S. Standard Sieve no. 70 (0.21mm)

b. total open area of filter should not exceed 10%.

\*EOS - Equivalent opening size compared to a U.S. standard sieve size.

No filter fabric should have less than 4% open area or an EOS less than U.S. Standard Sieve No. 100 (0.15 mm). The permeability of the fabric must be greater than that of the soil. The fabric may be made of woven or nonwoven monofilament yarns and should meet the following minimum requirements:

- thickness 20 - 60 mils,
- grab strength 90 - 120 lb,
- conform to ASTM D-1682 or ASTM D-177.

Filter blankets should always be provided where seepage is significant or where flow velocity and duration of flow or turbulence may cause the underlying soil particles to move through the riprap.

## Construction Specifications

**Subgrade preparation**—Prepare the subgrade for riprap and filter to the required lines and grades shown on the plans. Compact any fill required in the subgrade to a density approximating that of the surrounding undisturbed material or overfill depressions with riprap. Remove brush, trees, stumps, and other objectionable material. Cut the subgrade sufficiently deep that the finished grade of the riprap will be at the elevation of the surrounding area. Channels should be excavated sufficiently to allow placement of the riprap in a manner such that the finished inside dimensions and grade of the riprap meet design specifications.

**Sand and gravel filter blanket**—Place the filter blanket immediately after the ground foundation is prepared. For gravel, spread filter stone in a uniform layer to the specified depth. Where more than one layer of filter material is used, spread the layers with minimal mixing.

**Synthetic filter fabric**—Place the cloth filter directly on the prepared foundation. Overlap the edges by at least 12 inches, and space anchor pins every 3 ft along the overlap. Bury the upper and lower ends of the cloth a minimum of 12 inches below ground. Take care not to damage the cloth when placing riprap. If damage occurs remove the riprap and repair the sheet by adding another layer

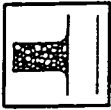

**Definition** A graveled area or pad located at points where vehicles enter and leave a construction site.

**Purpose** To provide a buffer area where vehicles can drop their mud and sediment to avoid transporting it onto public roads, to control erosion from surface runoff, and to help control dust.

**Conditions Where Practice Applies** Wherever traffic will be leaving a construction site and moving directly onto a public road or other paved off-site area. Construction plans should limit traffic to properly constructed entrances.

**Design Criteria** Aggregate Size—Use 2-3 inch washed stone.

**Dimensions of gravel pad—**

Thickness: 6 inches minimum

Width: 12-ft minimum or full width at all points of the vehicular entrance and exit area, whichever is greater

Length: 50-ft minimum

**Location—**Locate construction entrances and exists to limit sediment from leaving the site and to provide for maximum utility by all construction vehicles (Figure 6.06a). Avoid steep grades and entrances at curves in public roads.

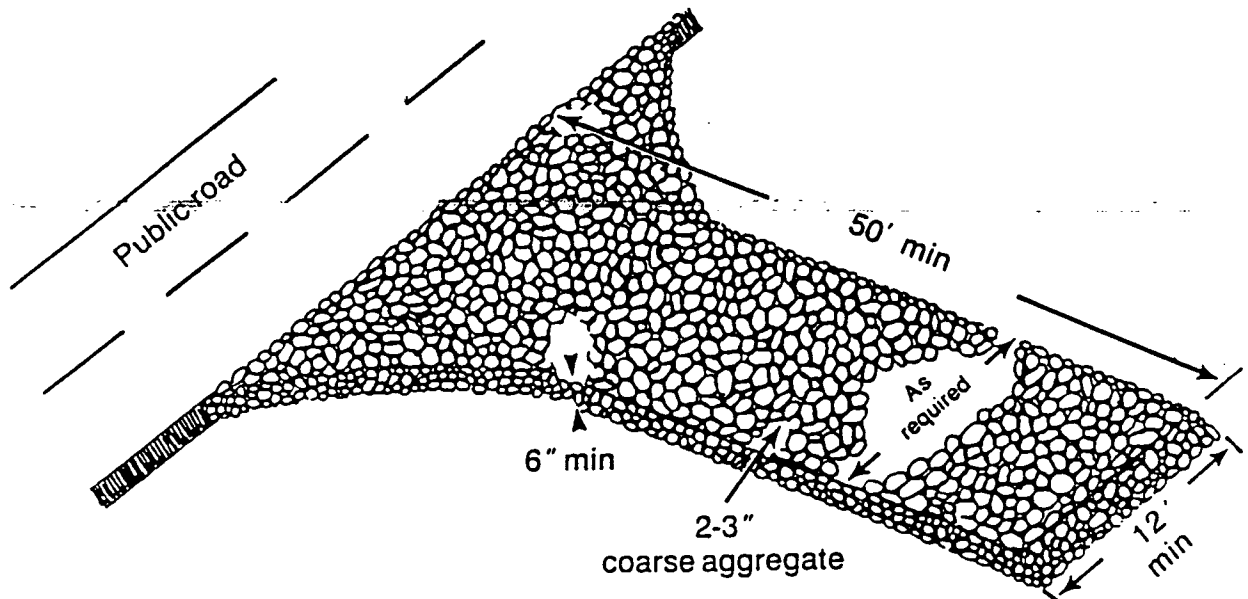

Figure 6.06a Gravel entrance/exit keeps sediment from leaving the construction site (modified from Va SWCC).

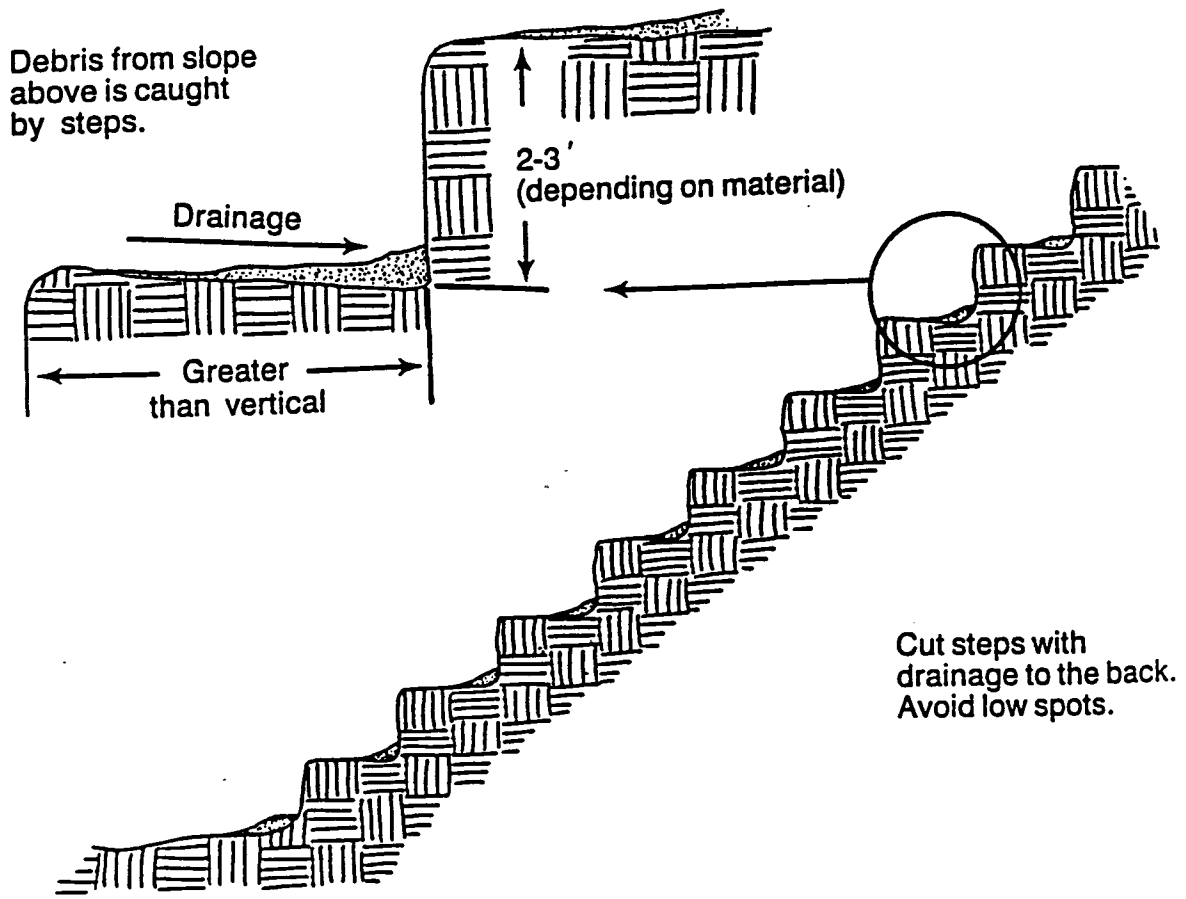

Figure 6.03b Stair stepping cut slopes (modified from Va SWCC).

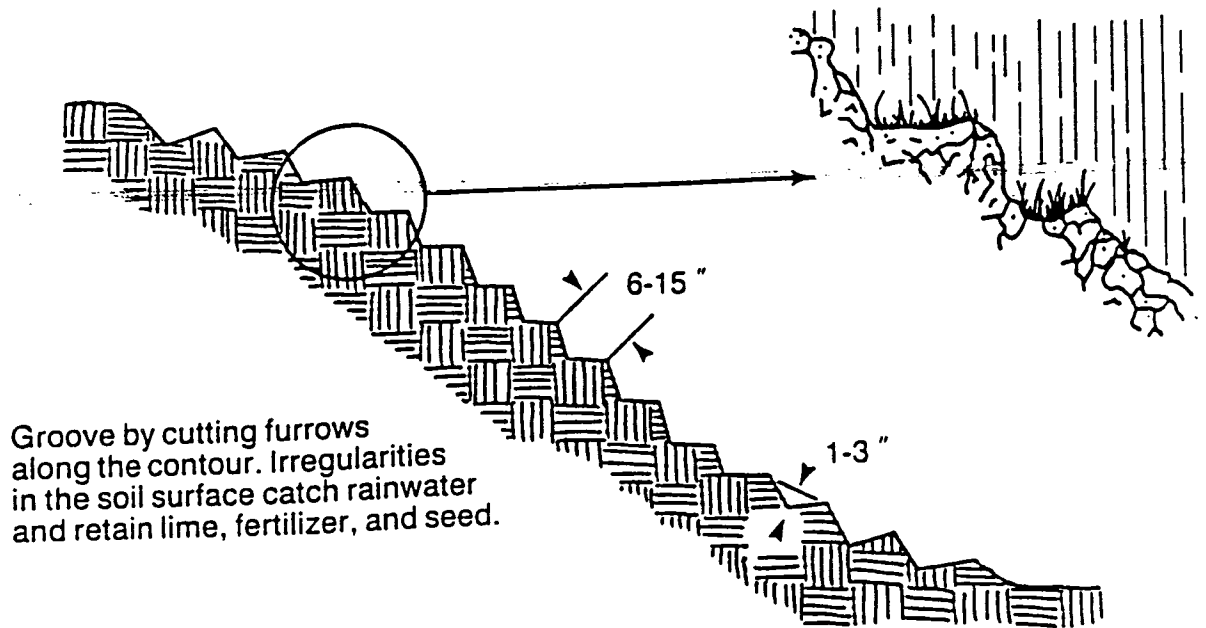
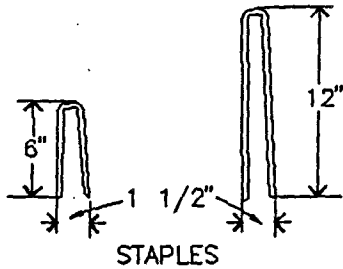
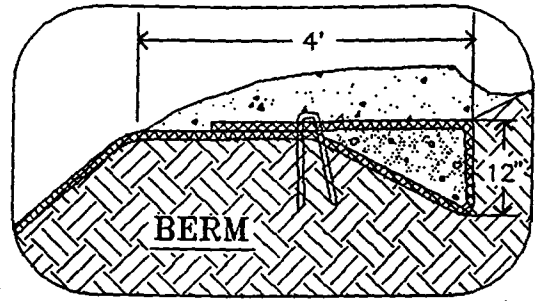

Figure 6.03c Grooving slopes (modified from Va SWCC).



STAPLES

MATS/BLANKETS SHOULD BE INSTALLED VERTICALLY DOWNSLOPE.



BERM

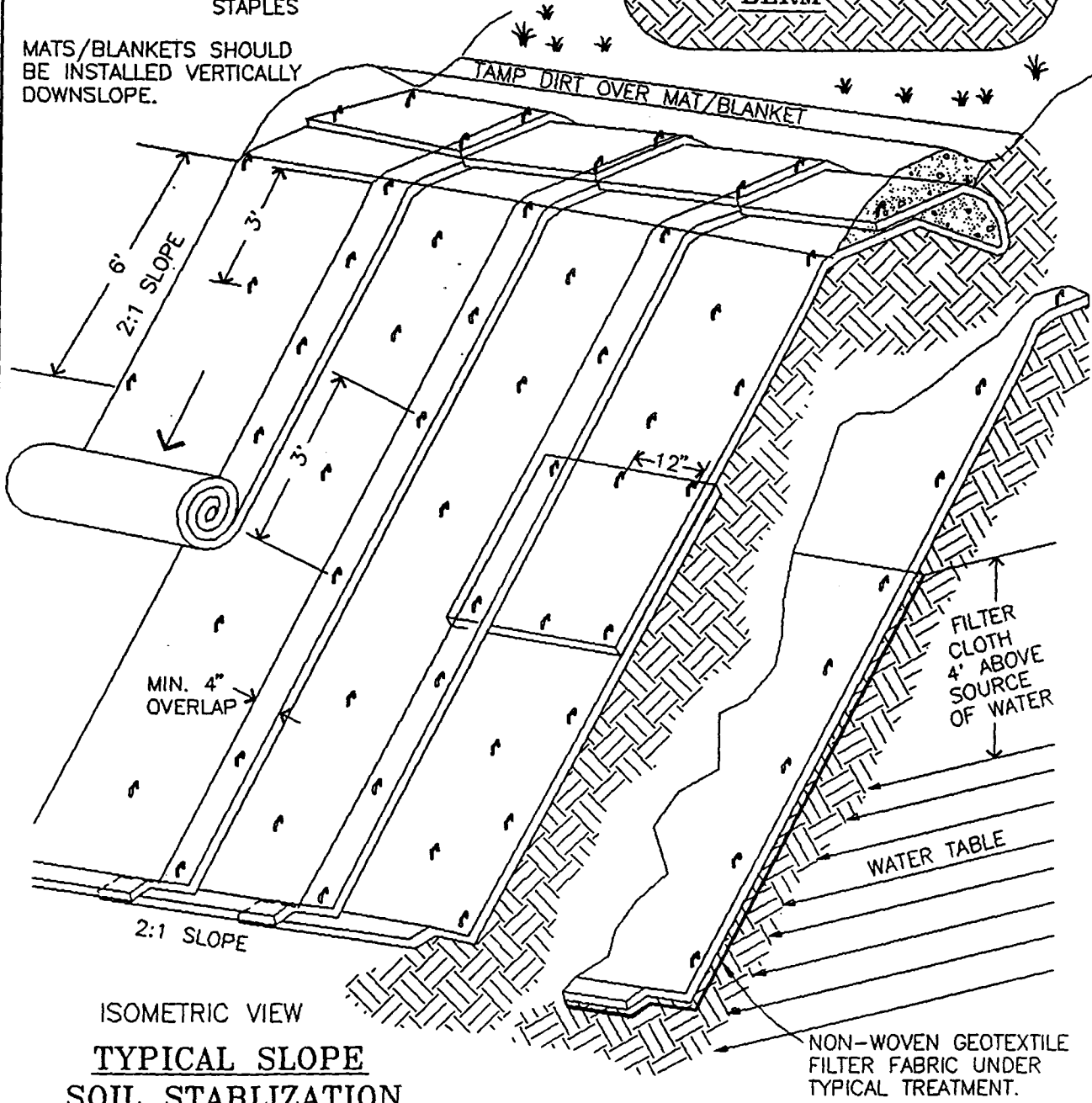

ISOMETRIC VIEW

**TYPICAL SLOPE  
SOIL STABILIZATION**

**WET SLOPE LINING**

NOTES:

1. SLOPE SURFACE SHALL BE FREE OF ROCKS, CLODS, STICKS AND GRASS. MATS/BLANKETS SHALL HAVE GOOD SOIL CONTACT.
2. LAY BLANKETS LOOSELY AND STAKE OR STAPLE TO MAINTAIN DIRECT CONTACT WITH THE SOIL. DO NOT STRETCH.

FILE: BLNKT02

**EROSION BLANKETS &  
TURF REINFORCEMENT MATS  
SLOPE INSTALLATION**

Debris from slope above is caught by steps.

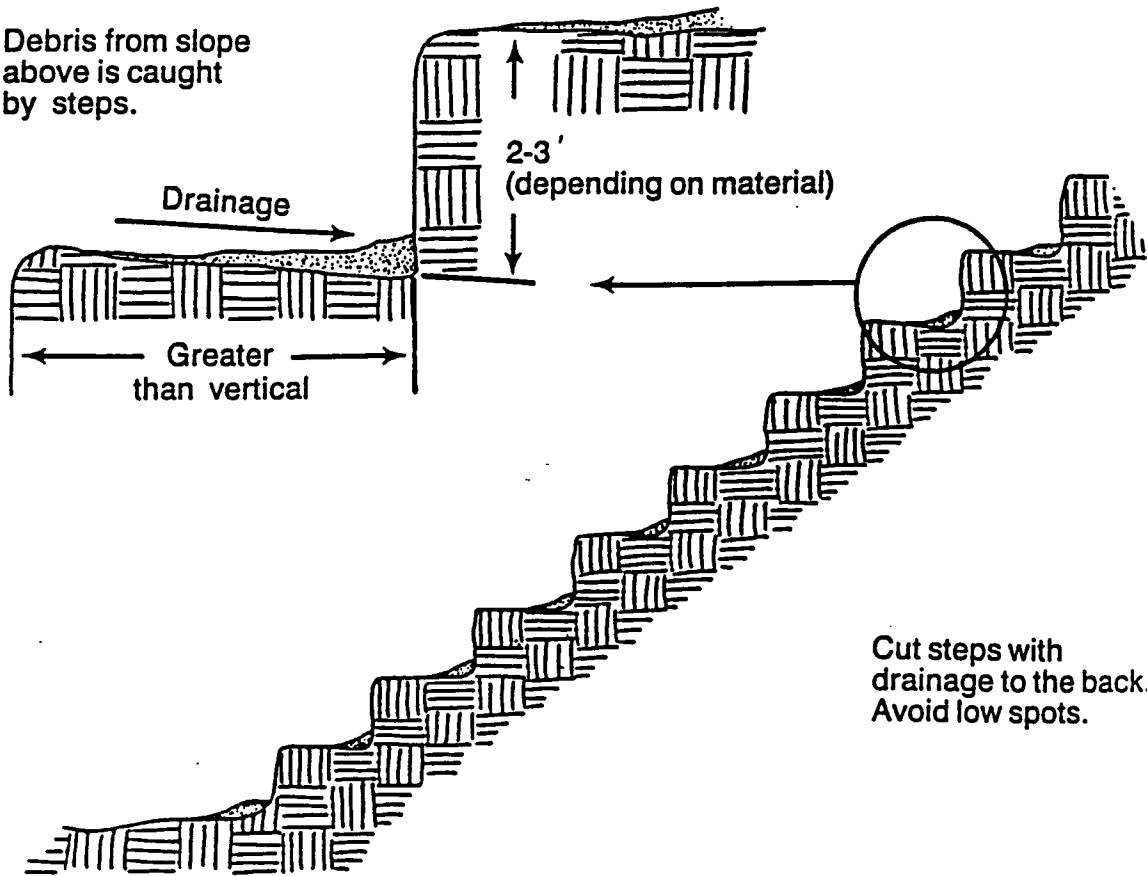

Cut steps with drainage to the back. Avoid low spots.

Figure 6.03b Stair stepping cut slopes (modified from Va SWCC).

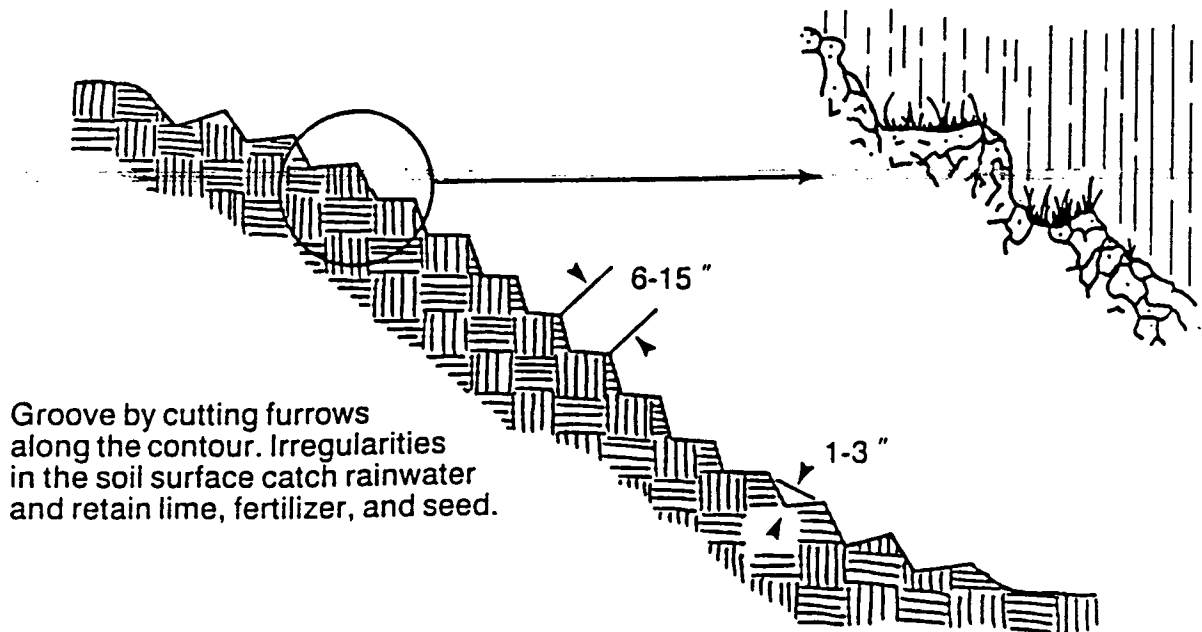

Groove by cutting furrows along the contour. Irregularities in the soil surface catch rainwater and retain lime, fertilizer, and seed.

Figure 6.03c Grooving slopes (modified from Va SWCC).



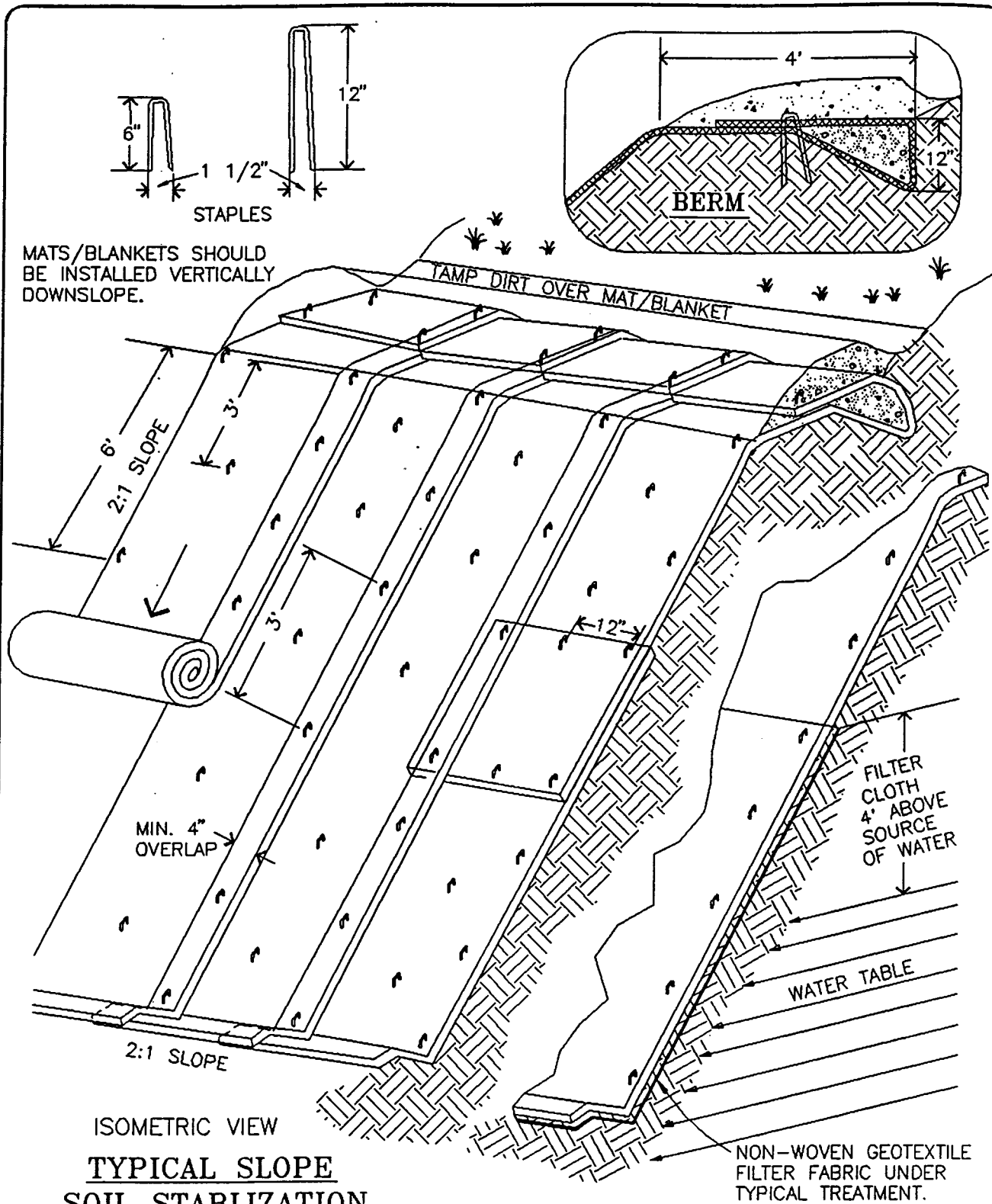

NOTES:

1. SLOPE SURFACE SHALL BE FREE OF ROCKS, CLODS, STICKS AND GRASS. MATS/BLANKETS SHALL HAVE GOOD SOIL CONTACT.
2. LAY BLANKETS LOOSELY AND STAKE OR STAPLE TO MAINTAIN DIRECT CONTACT WITH THE SOIL. DO NOT STRETCH.

FILE: BLNKT02

**EROSION BLANKETS & TURF REINFORCEMENT MATS SLOPE INSTALLATION**

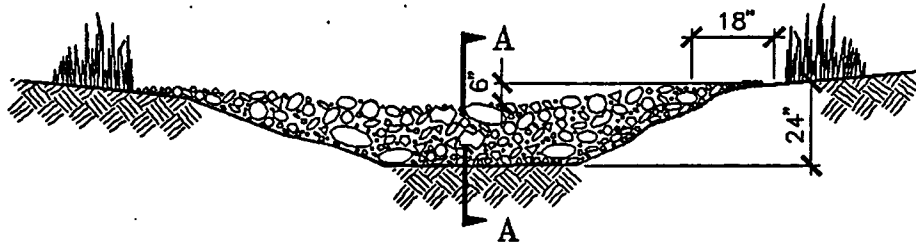

VIEW LOOKING UPSTREAM

NOTE:  
 KEY STONE INTO THE DITCH BANKS  
 AND EXTEND IT BEYOND THE ABUTMENTS  
 A MINIMUM OF 18" TO PREVENT OVER  
 FLOW AROUND DAM.

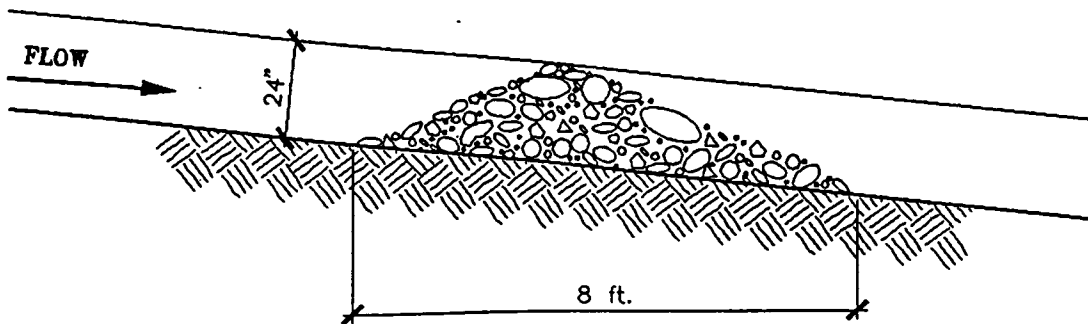

SECTION A - A

'L' = THE DISTANCE SUCH THAT POINTS 'A' AND  
 'B' ARE OF EQUAL ELEVATION.

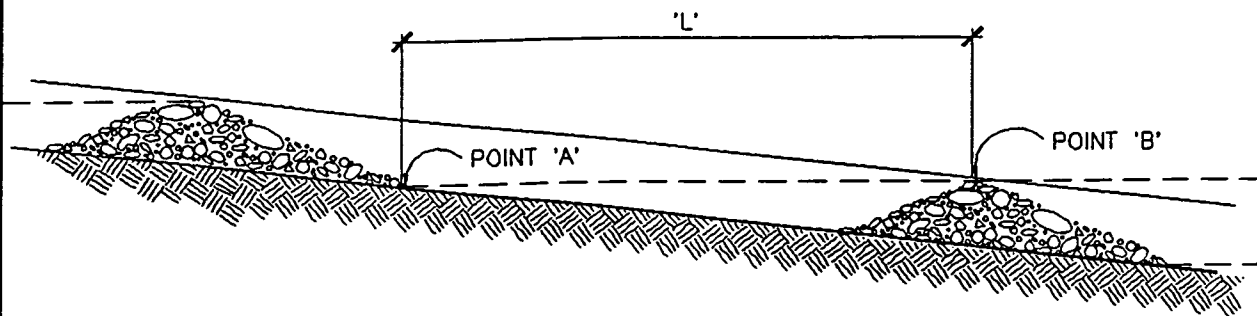

SPACING BETWEEN CHECK DAMS

**ROCK  
CHECK DAM**

WILLOW CUTTING AND PLANTING  
 SHOULD BE PERFORMED WHEN  
 PLANT MATERIAL IS DORMANT.  
 (NOVEMBER - APRIL)

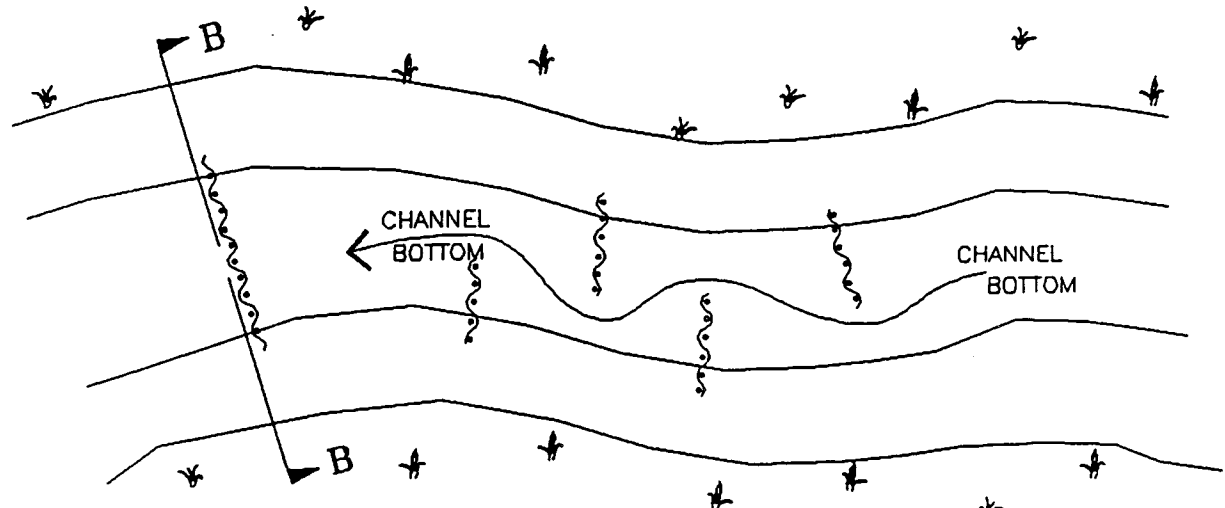
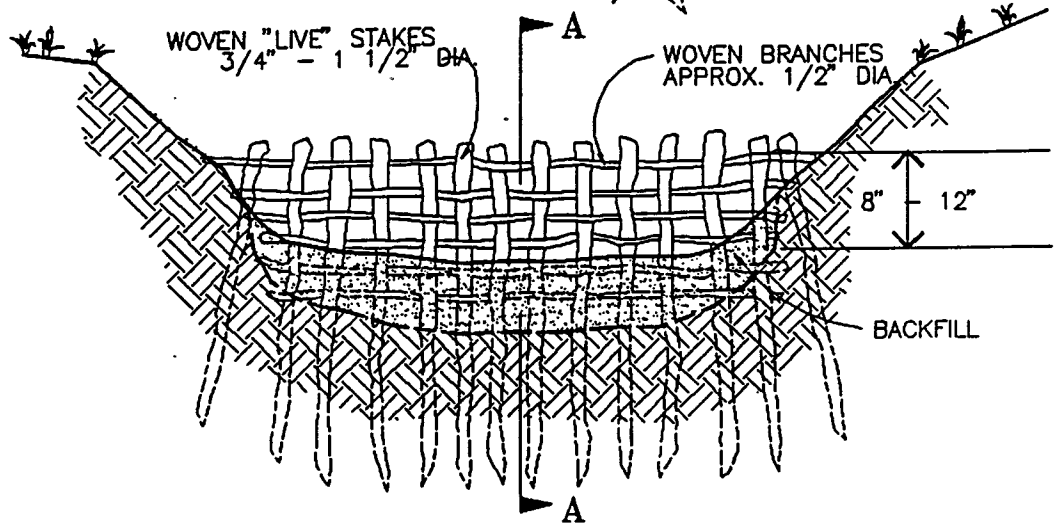
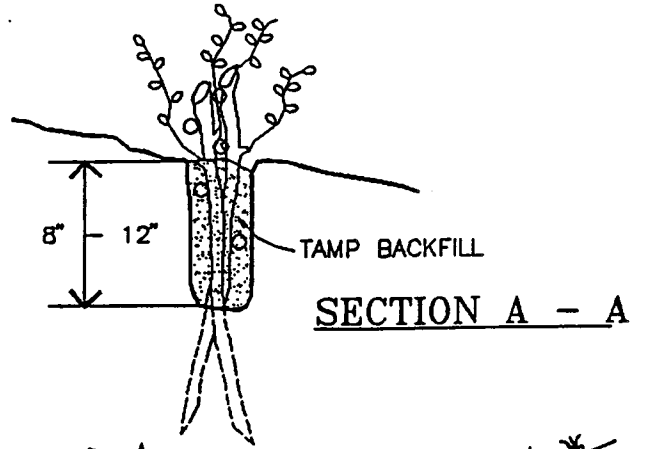

WOVEN WILLOW (LIVE) CHECKDAMS  
 ACT AS VELOCITY DISSIPATORS  
 TO REDUCE GULLY DOWNCUTTING

**WOVEN WILLOW  
 CHECK DAM**

© 1994 JOHN McCULLAH

FILE: GULLY04

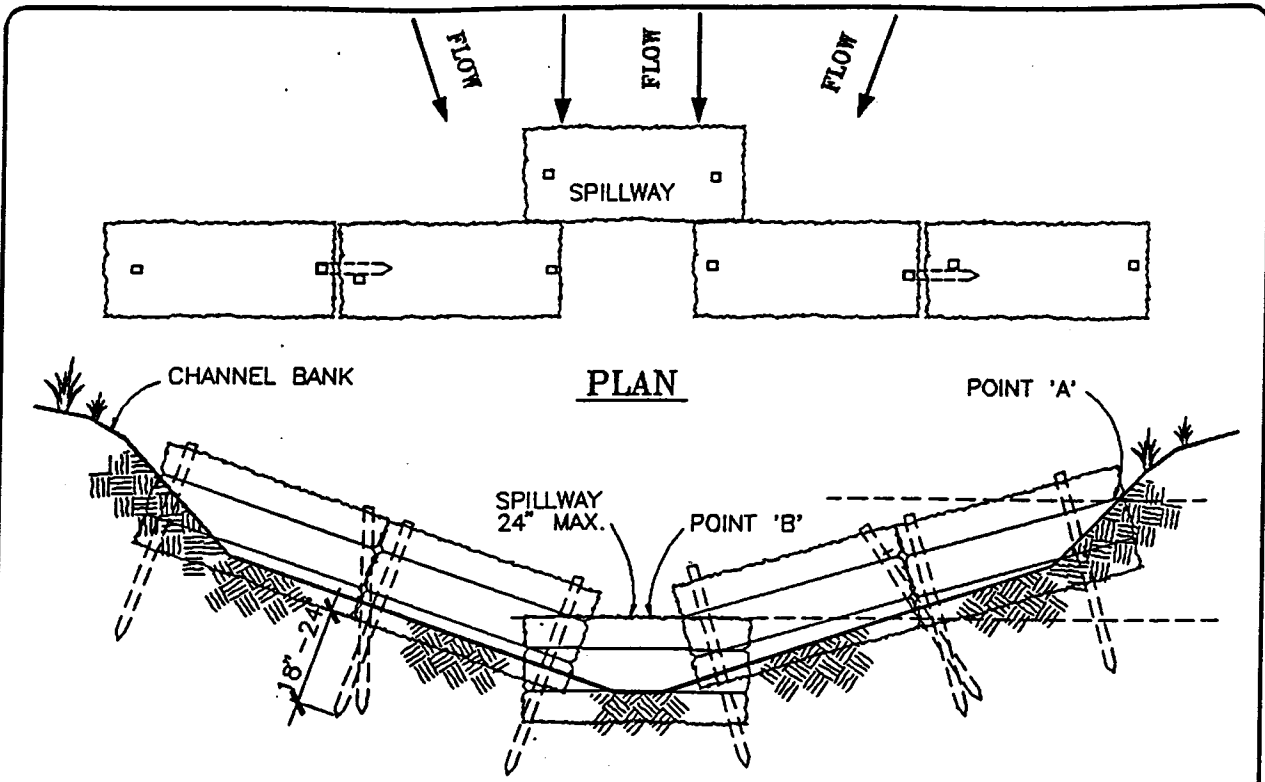

**VIEW LOOKING UPSTREAM**

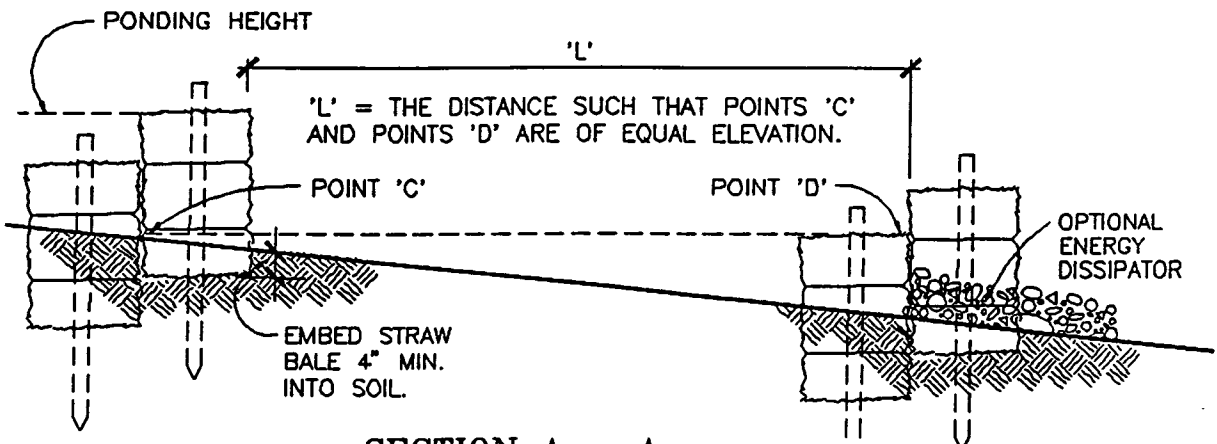

**SECTION A - A  
SPACING BETWEEN CHECK DAMS**

**NOTES:**

1. EMBED BALES 4" INTO THE SOIL AND 'KEY' BALES INTO THE CHANNEL BANKS.
2. POINT 'A' MUST BE HIGHER THAN POINT 'B'. (SPILLWAY HEIGHT)
3. PLACE BALES PERPENDICULAR TO THE FLOW WITH ENDS TIGHTLY ABUTTING. USE STRAW, ROCKS OR FILTER FABRIC TO FILL ANY GAPS AND TAMP BACKFILL MATERIAL TO PREVENT EROSION OR FLOW AROUND THE BALES.
4. SPILLWAY HEIGHT SHALL NOT EXCEED 24".
5. INSPECT AFTER EACH SIGNIFICANT STORM, MAINTAIN AND REPAIR PROMPTLY.

**STRAW BALE  
CHECK DAM**

© 1994 JOHN McCULLAH

FILE: GULLY05

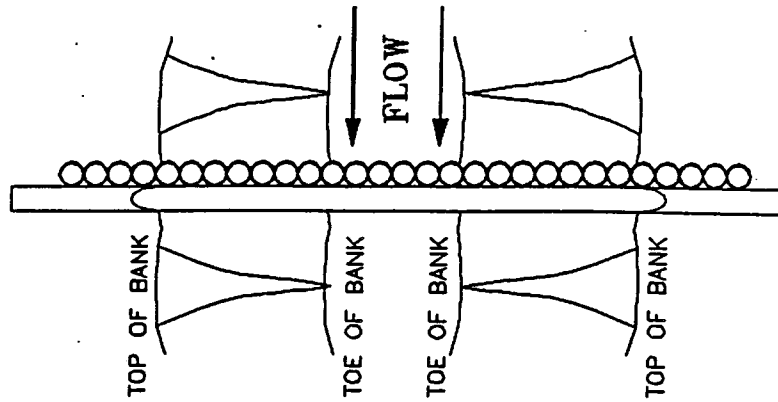

PLAN VIEW

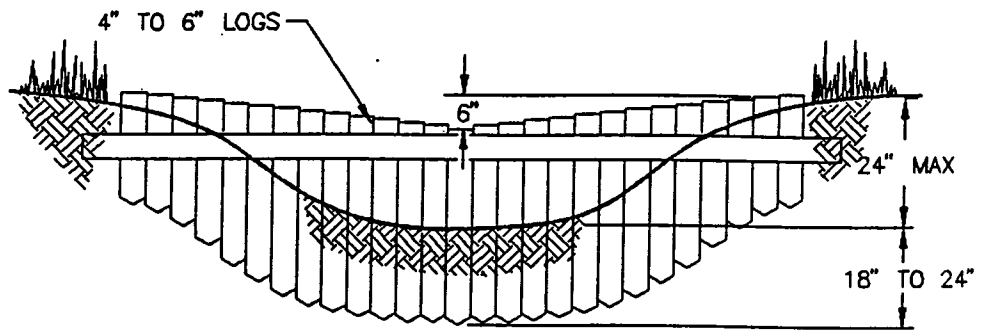

VIEW LOOKING UPSTREAM

'L' = THE DISTANCE SUCH THAT POINTS 'A' AND 'B' ARE OF EQUAL ELEVATION

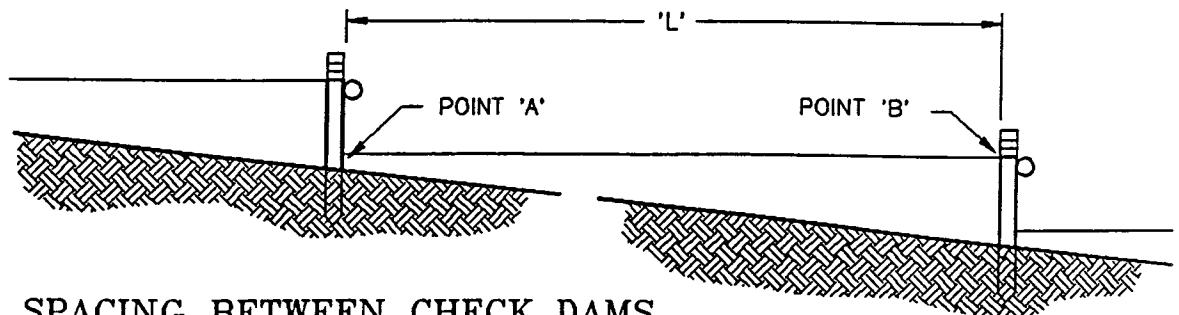

SPACING BETWEEN CHECK DAMS

NOTE:  
 KEY THE ENDS OF THE CHECK DAM INTO THE CHANNEL BANK.  
 LOGS SHALL BE PRESSURE TREATED IF GRADE STABILIZATION STRUCTURE IS INTENDED TO BE PERMANENT.

**LOG  
CHECK DAM**

© 1994 JOHN McCULLAH

FILE: GULLY02

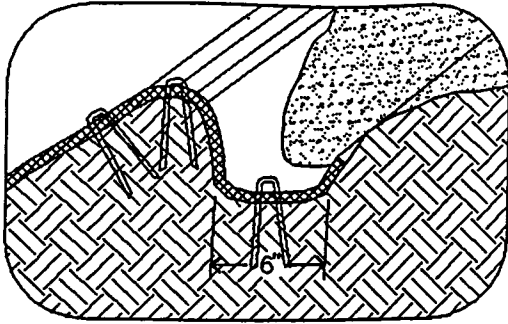

LONGITUDINAL ANCHOR TRENCH

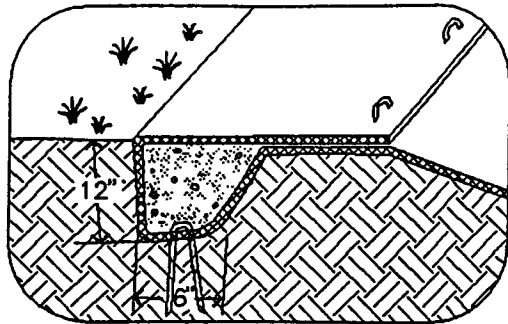

TERMINAL SLOPE AND CHANNEL ANCHOR TRENCH

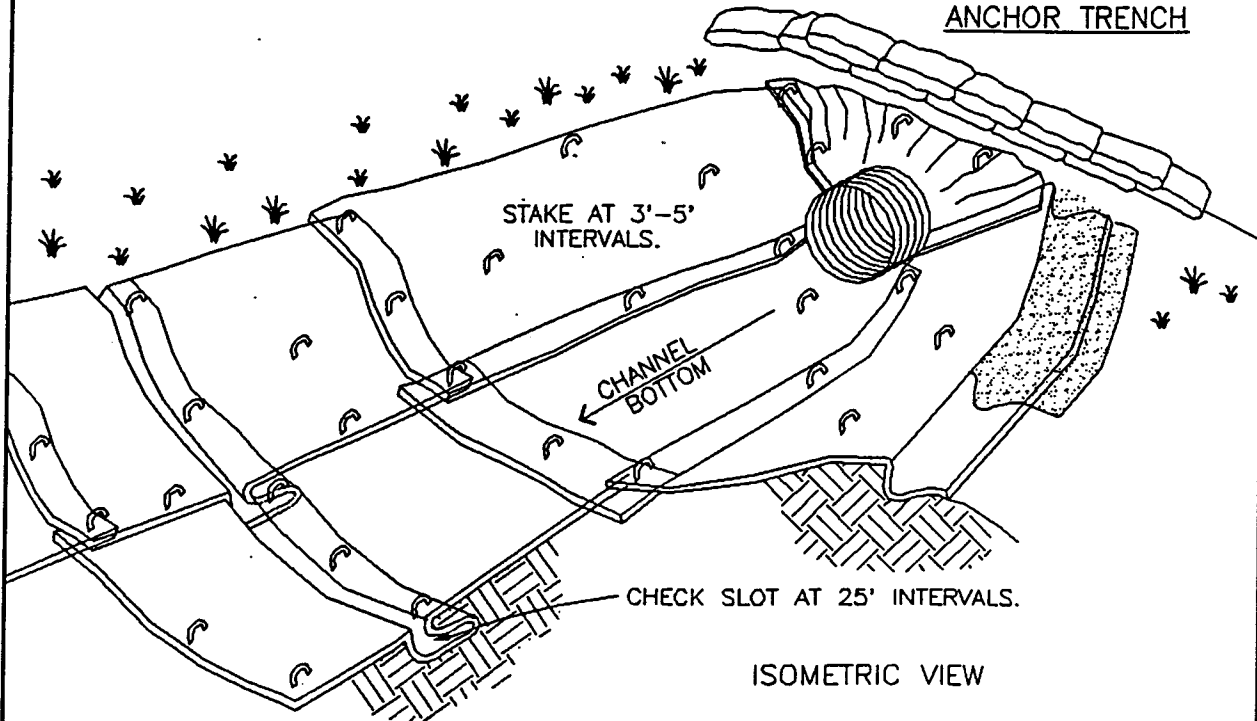

ISOMETRIC VIEW

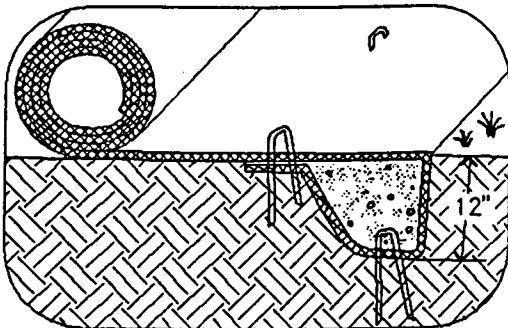

INITIAL CHANNEL ANCHOR TRENCH

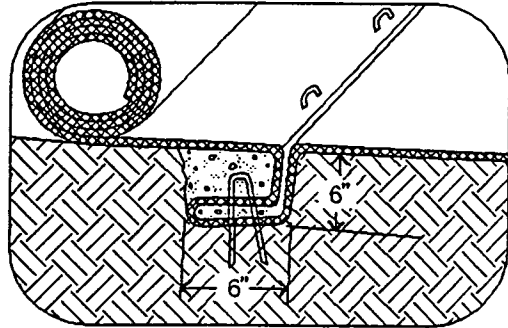

INTERMITTENT CHECK SLOT

NOTES:

1. CHECK SLOTS TO BE CONSTRUCTED PER MANUFACTURERS SPECIFICATIONS.
2. STAKING OR STAPLING LAYOUT PER MANUFACTURERS SPECIFICATIONS.

**EROSION BLANKETS &  
TURF REINFORCEMENT MATS  
CHANNEL INSTALLATION**

© 1994 JOHN McCULLAH

FILE: BLNKTO1

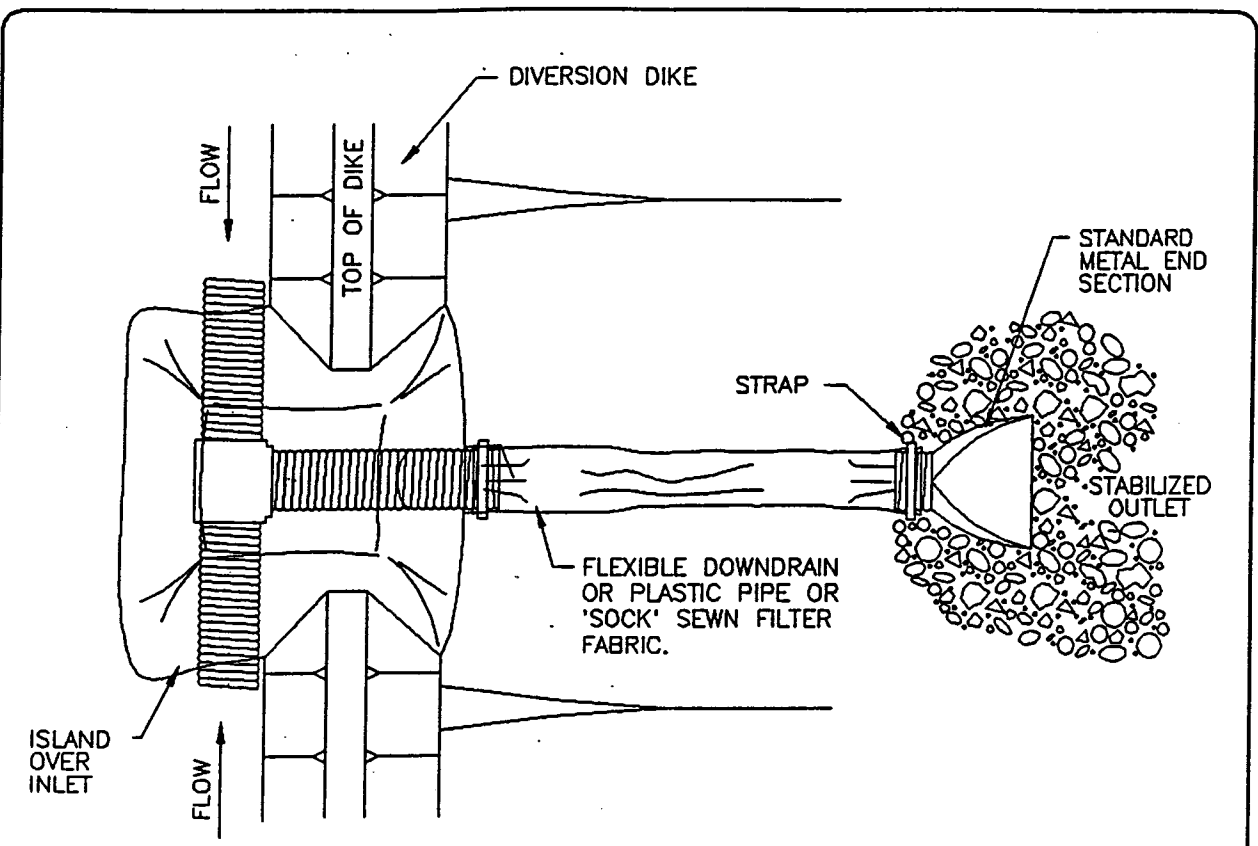

PLAN VIEW

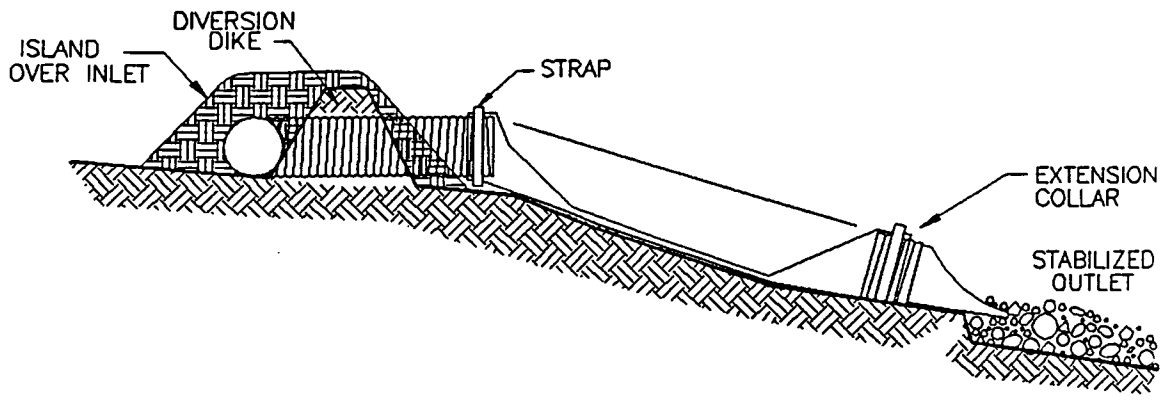

SECTION

SLOPE DRAIN

© 1994 JOHN McCULLAH

FILE: RNOFF03

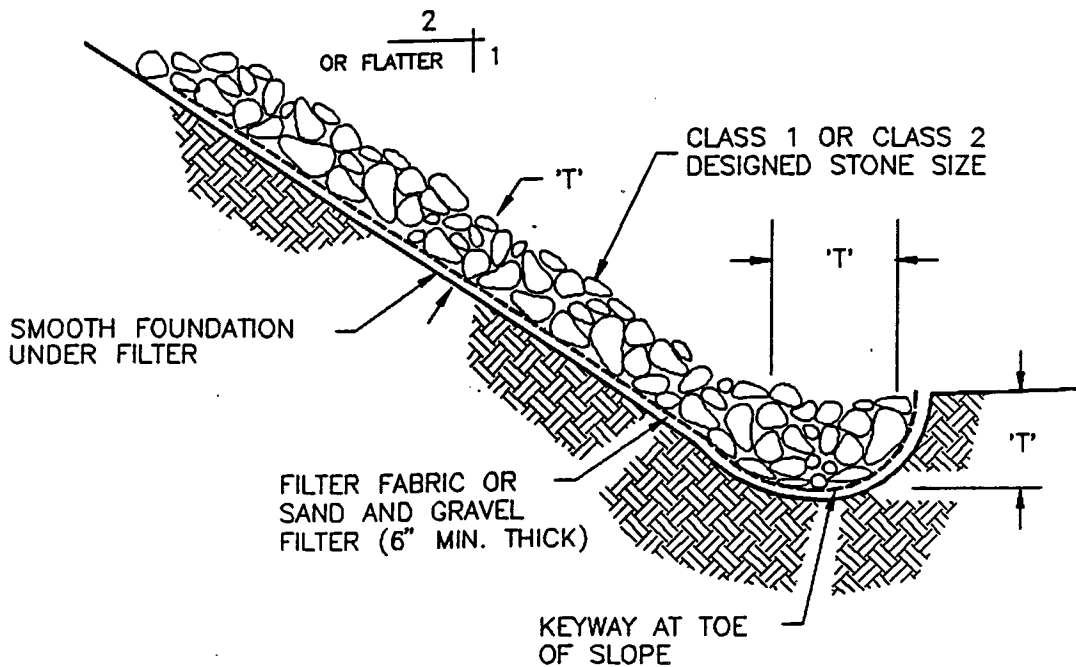

TYPICAL SECTION

NOTE:

'T' = THICKNESS : THICKNESS SHALL BE DETERMINED BY THE ENGINEER.

MINIMUM THICKNESS SHALL BE 1.5x THE MAXIMUM STONE DIAMETER, NEVER LESS THAN 6 INCHES.

**RIPRAP  
PROTECTION**

© 1994 JOHN McCULLAH

FILE: RNOFF02



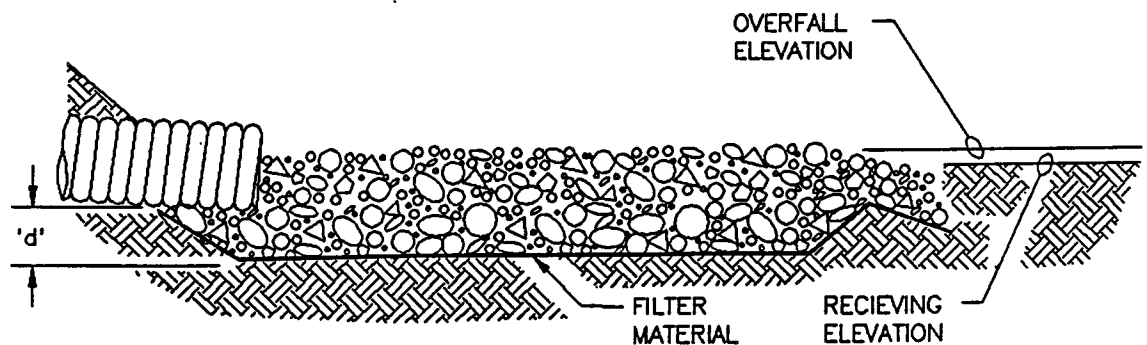

THICKNESS ('d') = 1.5 x MAX ROCK DIAMETER (6" MIN.)

SECTION

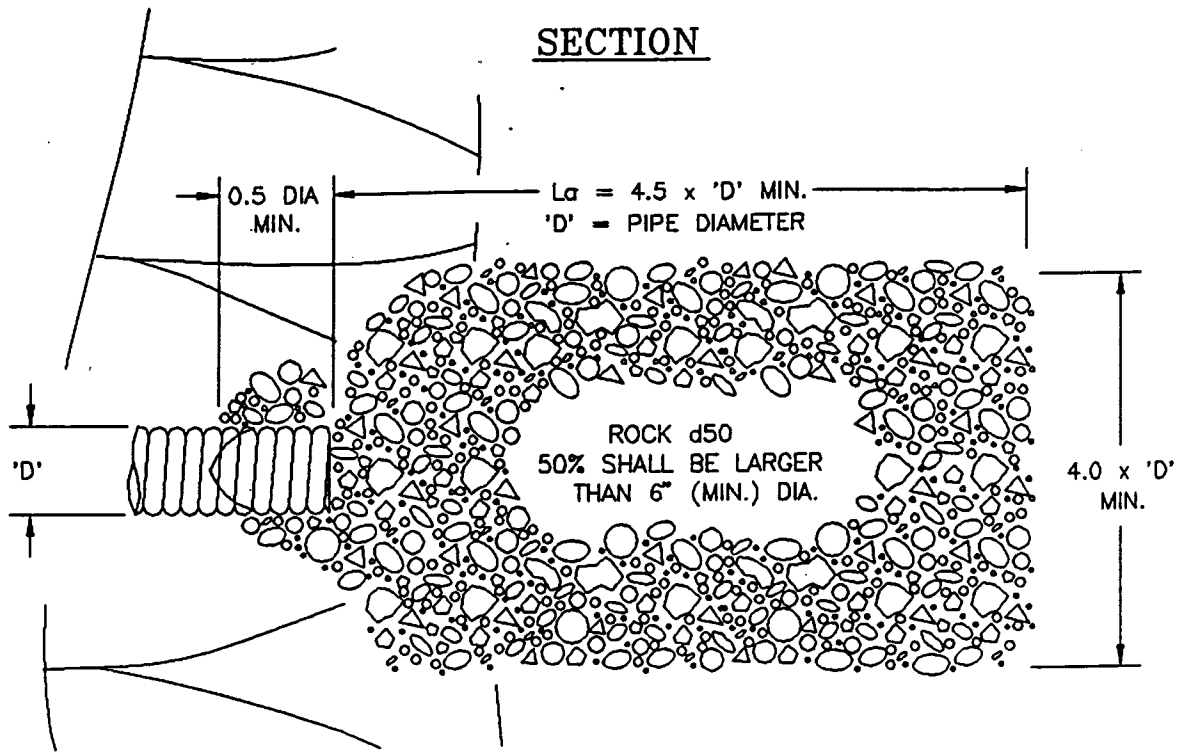

PLAN

NOTES:

1. 'La' = LENGTH OF APRON. DISTANCE 'La' SHALL BE OF SUFFICIENT LENGTH TO DISSIPATE ENERGY.
2. APRON SHALL BE SET AT A ZERO GRADE AND ALIGNED STRAIGHT.
3. FILTER MATERIAL SHALL BE FILTER FABRIC OR 6" THICK (MIN.) GRADED GRAVEL LAYER.

**ENERGY  
DISSIPATOR**

© 1994 JOHN McCULLAH

FILE: RNOFF06

DIVERSION RIDGE REQUIRED  
WHERE GRADE EXCEEDS 2%

2% OR GREATER

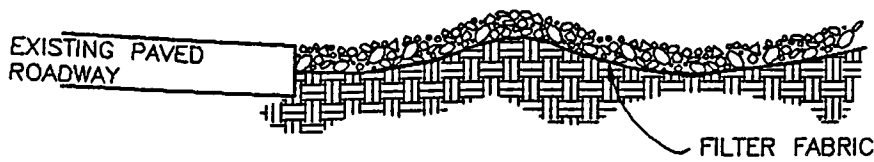

**SECTION A - A**

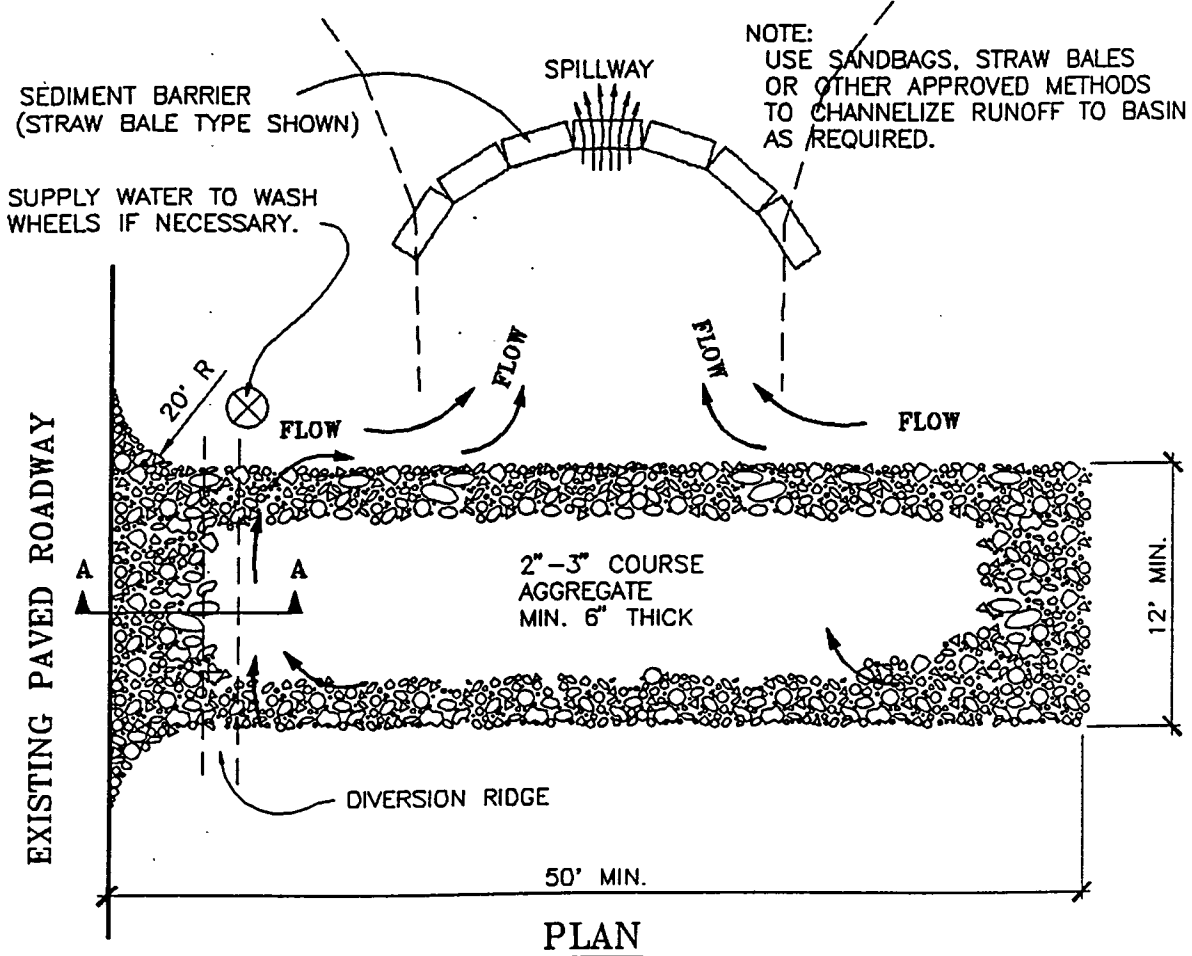

**NOTES:**

1. THE ENTRANCE SHALL BE MAINTAINED IN A CONDITION THAT WILL PREVENT TRACKING OR FLOWING OF SEDIMENT ONTO PUBLIC RIGHTS-OF-WAY. THIS MAY REQUIRE TOP DRESSING, REPAIR AND/OR CLEANOUT OF ANY MEASURES USED TO TRAP SEDIMENT.
2. WHEN NECESSARY, WHEELS SHALL BE CLEANED PRIOR TO ENTRANCE ONTO PUBLIC RIGHT-OF-WAY.
3. WHEN WASHING IS REQUIRED, IT SHALL BE DONE ON AN AREA STABILIZED WITH CRUSHED STONE THAT DRAINS INTO AN APPROVED SEDIMENT TRAP OR SEDIMENT BASIN.

**TEMPORARY  
GRAVEL  
CONSTRUCTION  
ENTRANCE/EXIT**

© 1994 JOHN McCULLAN

FILE: GRADE06

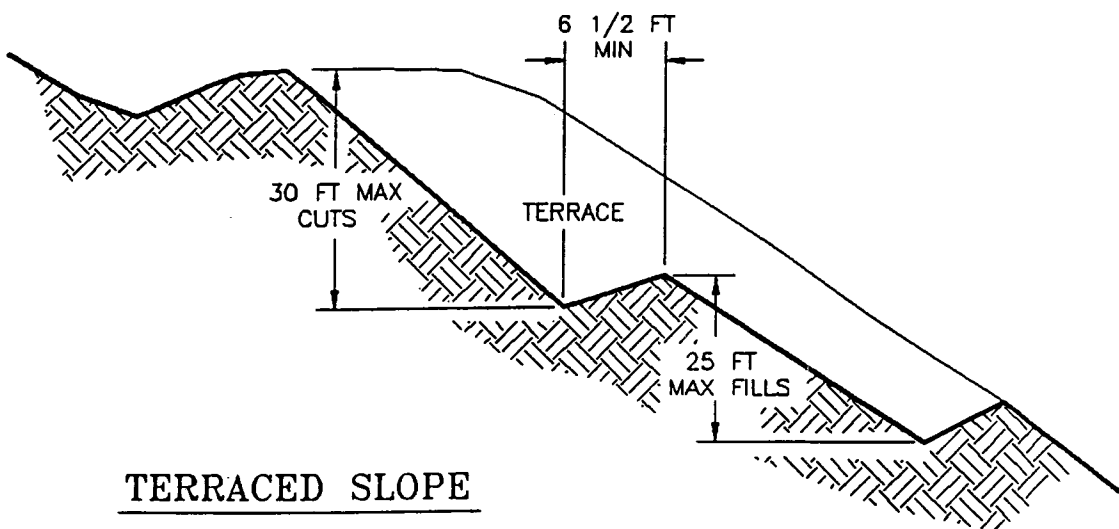
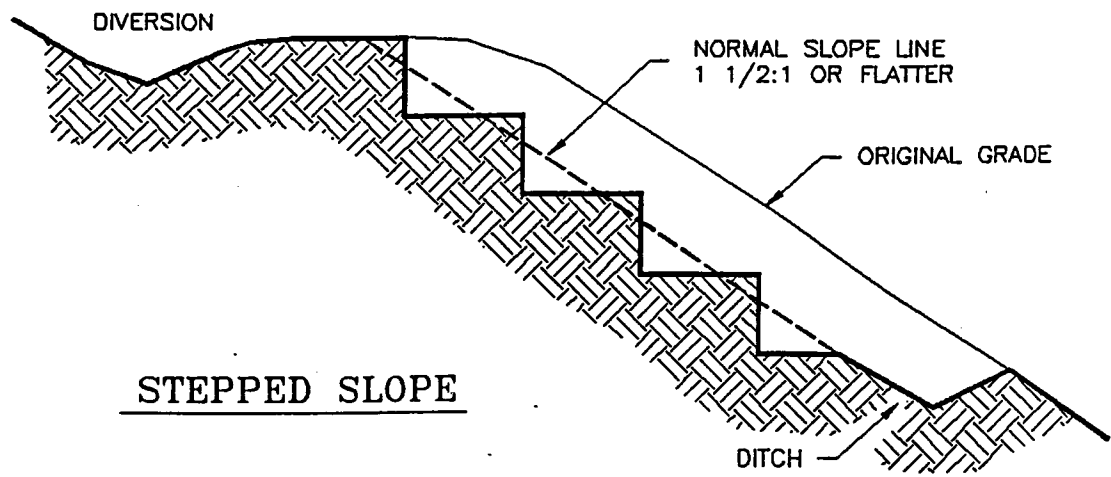

- NOTES:
1. VERTICAL CUT DISTANCE SHALL BE LESS THAN HORIZONTAL DISTANCE.
  2. VERTICAL CUT SHALL NOT EXCEED 2 FT. IN SOFT MATERIAL AND 3 FT. IN ROCKY MATERIAL.

**STEPPED OR  
TERRACED SLOPE**

© 1994 JOHN McCULLAH

FILE: GRADE02

