



Guidelines for Deploying Weather Responsive Operations in TxDOT Traffic Signals

Technical Report 0-6861-1

Cooperative Research Program

TEXAS A&M TRANSPORTATION INSTITUTE
COLLEGE STATION, TEXAS

in cooperation with the
Federal Highway Administration and the
Texas Department of Transportation
<http://tti.tamu.edu/documents/0-6861-1.pdf>

1. Report No. FHWA/TX-17/0-6861-1		2. Government Accession No.		3. Recipient's Catalog No.	
4. Title and Subtitle GUIDELINES FOR DEPLOYING WEATHER RESPONSIVE OPERATIONS IN TXDOT TRAFFIC SIGNALS				5. Report Date February 2017	
				6. Performing Organization Code	
7. Author(s) Kevin N. Balke, Nadeem Chaudhary, Srinivasa Sunkari, Hassan Charara, David Florence, Charles Stevens, Geza Pesti and Jonathan Tydlacka				8. Performing Organization Report No. Report 0-6861-1	
9. Performing Organization Name and Address Texas A&M Transportation Institute College Station, Texas 77843-3135				10. Work Unit No. (TRAIS)	
				11. Contract or Grant No. Project 0-6861	
12. Sponsoring Agency Name and Address Texas Department of Transportation Research and Technology Implementation Office 125 E. 11 th Street Austin, Texas 78701-2483				13. Type of Report and Period Covered Technical Report: February 2015–December 2016	
				14. Sponsoring Agency Code	
15. Supplementary Notes Project performed in cooperation with the Texas Department of Transportation and the Federal Highway Administration. Project Title: Improving Safety and Efficiency of Signalized Intersections During Inclement Weather URL: http://tti.tamu.edu/documents/0-6861-1.pdf					
16. Abstract Inclement weather, such as rain, snow, fog, and ice, create special operational challenges for traffic management agencies. This project provided Texas Department of Transportation with technical guidance for improving safety and efficiency of signalized intersections during inclement weather. As part of this project, the research team examined available technologies for detecting adverse weather at signalized intersections and provided technical guidance on strategies for modifying traffic signal operations during various types of weather events. A realistic and practical architectural framework for collecting and disseminating weather information to improve signalized intersection operations was developed by the research team. The research team deployed the architecture at intersections in Dumas, Burleson, and Nassau Bay and conducted simulation and field studies to explore the benefits of providing weather responsive traffic signal operations. The research team also provided guidance for operating traffic signals and developing traffic signal timing plans for large scale evacuations, such as hurricane evacuations in coastal regions.					
17. Key Words Traffic Signals, Operations, Weather, Weather Responsive, Traffic Signal Timing			18. Distribution Statement No restrictions. This document is available to the public through NTIS: National Technical Information Service Alexandria, Virginia http://www.ntis.gov		
19. Security Classif. (of this report) Unclassified		20. Security Classif. (of this page) Unclassified		21. No. of Pages 176	22. Price

GUIDELINES FOR DEPLOYING WEATHER RESPONSIVE OPERATIONS IN TXDOT TRAFFIC SIGNALS

by

Kevin N. Balke, Ph.D., P.E., PMP
Senior Research Engineer
Texas A&M Transportation Institute

David Florence
Graduate Research Assistant
Texas A&M Transportation Institute

Nadeem Chaudhary, Ph.D., P.E.
Senior Research Engineer
Texas A&M Transportation Institute

Charles Stevens, P.E.
Research Engineer
Texas A&M Transportation Institute

Srinivasa Sunkari, P.E.
Research Engineer
Texas A&M Transportation Institute

Geza Pesti, Ph.D., P.E.
Research Engineer
Texas A&M Transportation Institute

Hassan Charara
Research Scientist
Texas A&M Transportation Institute

Jonathan Tydlacka, P.E.,
Assistant Research Engineer
Texas A&M Transportation Institute

Report 0-6861-1

Project 0-6861

Project Title: Improving Safety and Efficiency of Signalized Intersections During Inclement
Weather

Performed in cooperation with the
Texas Department of Transportation
and the
Federal Highway Administration

February 2017

TEXAS A&M TRANSPORTATION INSTITUTE
College Station, Texas 77843-3135

DISCLAIMER

This research was performed in cooperation with the Texas Department of Transportation (TxDOT) and the Federal Highway Administration (FHWA). The contents of this report reflect the views of the authors, who are responsible for the facts and the accuracy of the data presented herein. The contents do not necessarily reflect the official view or policies of the FHWA or TxDOT. This report does not constitute a standard, specification, or regulation.

This report is not intended for construction, bidding, or permit purposes. The engineer in charge of this project was Kevin N. Balke, P.E. #66529.

The United States Government and the State of Texas do not endorse products or manufacturers. Trade or manufacturers' names appear herein solely because they are considered essential to the object of this report.

ACKNOWLEDGMENTS

This project was conducted in cooperation with TxDOT and FHWA. The authors thank the following TxDOT employees for their assistance with this project:

- Sonya Badgley, PMP, Project Director.
- Ben Mebarkia.
- Billy Manning.
- Derryl Skinnell.
- Henry Wickes.
- John Benes.
- Rebecca Wells.
- Steven Swindell.
- Ugonna Ughanze.

The research team would also like to thank the following individuals from TxDOT for their assistance with the deployment of equipment in the field:

- Steve Chiu.
- Mike Rooney.
- Robert McKee.
- Mike Fowler.

Authors would also like to thank Ali Mozdbar, City of Fort Worth, for his assistance.

TABLE OF CONTENTS

	Page
List of Figures	xi
List of Tables	xiii
Chapter 1. Introduction	1
Project Objectives	1
Organization of Report	2
Chapter 2. Weather Impacts in Select TxDOT Districts	3
Characterization of Weather Impacts in Select TxDOT Districts	3
Abilene District	3
Amarillo District	3
Atlanta District.....	3
Austin District.....	4
Beaumont District	4
Brownwood District.....	4
Bryan District.....	4
Childress District	4
Dallas District	5
El Paso District	5
Fort Worth District.....	5
Laredo District	6
Lubbock District	6
Lufkin District.....	6
Odessa District	6
Paris District.....	6
Pharr District.....	7
San Angelo District.....	7
Tyler District.....	7
Wichita Falls District	7
Waco District	7
Yoakum District.....	7
Assessment of Weather Events in Each District.....	8
Temperatures.....	9
Precipitation	13
Chapter 3. Weather Monitoring Equipment to Support Weather Responsive Traffic	
Signal Operations	21
Potential Impact of Adverse Weather on Signal Operations	21
Desired Controllers Features	23
Weather Monitoring Technologies	24
Wind Sensors	24
Precipitation Sensors.....	24
Radiation Sensors.....	25
Visibility Sensors	25
Temperature/Dewpoint Sensors.....	26

Barometric Pressure Sensors.....	26
Road Surface Sensors	27
Water Level and Snow Depth Sensors.....	27
Guidelines for Siting and Installing Weather Monitoring Technologies at Intersections	27
Road Weather Information Requirements	28
Application of the Guide to Deploy ESS at Signalized Intersections.....	31
User Needs Assessment.....	34
Potential Architectures.....	35
Weather Station Interface with the Traffic Signal System	36
Interface with the Traffic Signal Infrastructure	36
Interface with a Local Controller at an Isolated Signal	36
Interface with a Multiple Signal System in a Closed Loop Traffic Management System.....	36
Interface with a Signal System Using a Local Field Master.....	37
Interface with a Signal System with Peer-to-Peer Communications	37
Potential Road Weather Sensor Technology Procurement Specifications	37
Roadway Visibility Sensor	37
Specification for Road Condition Sensor.....	38
Chapter 4. System Architecture to support Weather Responsive Traffic Signal	
Operations	41
Description of Sites.....	41
US 287 in Dumas, TX.....	42
SH 174 in Burleson, TX.....	43
Nasa Road 1	45
System Components	47
Pavement Surface Sensor.....	47
Visibility Sensor.....	49
Weather Station.....	49
Weather Processing Unit.....	50
General System Architecture	51
System Development and In-Lab Testing	52
Weather Sensors.....	53
Development of Site Specific Weather Responsive Actions/Architecture.....	53
Custom Computer Software.....	57
In-lab Testing of System Subcomponents and Site Specific Architecture	58
Chapter 5. Evaluation of Signal Timing Deployment Strategies.....	59
Field Deployments.....	59
US 287/US 87 in Dumas, TX	59
SH 174, Burleson, TX.....	64
NASA Road 1, Nassau Bay, TX.....	72
Lessons Learned and Implementation Guidelines	82
Weather and Pavement Monitoring Equipment.....	82
Weather Responsive Traffic Signal Timings	82
System Deployment and Calibration	83
Evaluation of System Performance.....	84

Chapter 6. Signal Timing Strategies and Practices During Large-Scale Weather	
Evacuations.....	85
Background.....	85
Methodology.....	85
Case Studies.....	86
Recommending Strategies.....	86
State-of-Practice Literature Review.....	86
Human Behavior, Demand, and Simulation.....	87
Simulated Signal Timing Adjustments for Evacuation.....	88
Evacuation Signal Timing by Public Agencies.....	90
Signal Timing Strategies for Special Events and Incidents.....	91
Texas Case Studies.....	91
City of Pasadena, Texas.....	91
I-10 Freeway Responsive System.....	95
Recommended Signal Timing Strategies During Hurricane Evacuation.....	98
For Maximum Vehicle Evacuation.....	99
For High Efficiency and Acceptable Driver Compliance.....	99
If Evacuation Demand Is Known.....	99
For Quick Implementation.....	99
Equitable Operations.....	99
Elements for Further Study.....	100
Chapter 7. Weather Responsive Signal Timing Guidelines.....	101
Overview.....	101
Concepts.....	101
Increase Vehicular Red Clearance Intervals.....	101
Increase Minimum Green Times.....	102
Implement Phase Recalls.....	102
Weather-Responsive Coordination Plans.....	103
Procedures.....	103
Step 1. Identify Operational Objectives.....	103
Step 2. Establish Performance Measures.....	104
Step 3. Assess Weather Impacts on Traffic Operations.....	104
Step 4. Develop Timing Strategies and Timing Values.....	105
Step 5. Implement and Observe.....	105
Step 6. Monitor and Maintain.....	105
Guidelines.....	106
Weather-Related Operations Impacts.....	106
Signal Timing Strategies.....	108
Establishing Thresholds for Activating and Deactivating Weather Responsive Timing Plans.....	111
References.....	113
Appendix A. Weather Responsive Timing Plans for US 87 in Dumas, TX.....	115
Appendix B. Weather Responsive Timing Plans for SH 1747 in Burleson, TX.....	119
Appendix C. Weather Responsive Timing Plans for NASA Road 1 in Nassau Bay, TX.....	127
Appendix D. Weather Responsive Timing Training Materials.....	131

LIST OF FIGURES

	Page
Figure 1. Mechanical Anemometer – Wind Speed Only.....	24
Figure 2. Sonic Anemometer – Wind Speed and Wind Direction.....	24
Figure 3. Propeller Anemometer – Wind Speed and Wind Direction.....	24
Figure 4. Radar Precipitation Sensor.....	25
Figure 5. Capacitive Transducer Sensor.....	25
Figure 6. Optical Visibility Sensor.....	25
Figure 7. Combination Temperature and Humidity Sensor.....	26
Figure 8. Combination Barometric Pressure, Temperature, and Humidity Sensor.....	26
Figure 9. Typical Sensor Configuration of an Environmental Sensor Station (2).....	30
Figure 10. Steps of RWIS ESS Siting.....	31
Figure 11. Tower Location Relative to Roadway.....	32
Figure 12. Pavement Sensor Placement.....	34
Figure 13. Map of Dumas Test Site.....	43
Figure 14. Map of Burleson System.....	44
Figure 15. Map of NASA Road 1 System.....	46
Figure 16. Pavement Surface Condition Monitor – Model 5433 “IceSight” by High Sierra Electronics.....	48
Figure 17. Typical Installation of Pavement Surface Monitoring Sensor – Off Signal Mast Arm.....	48
Figure 18. High Sierra Visibility Sensor – Model 5434-00.....	49
Figure 19. Vantage Pro 2 Weather Station and Monitoring Console produced by Davis Electronics.....	50
Figure 20. Weather Processing Unit.....	51
Figure 21. General System Architecture.....	52
Figure 22. Mock of Dumas Deployment in TTI Laboratory.....	54
Figure 23. Mock of Burleson Deployment in TTI Laboratory.....	55
Figure 24. Mock of Nasa Road 1 Deployment in TTI Laboratory.....	57
Figure 25. Site Location – US 287/US 87 in Dumas, TX.....	60
Figure 26. Location of Signalized Intersections – US 287/US 87, Dumas, TX.....	61
Figure 27. Weather and Road Surface Condition Monitoring Systems Deployed in Dumas, TX.....	62
Figure 28. Corridor Travel Times on US 287/US 87 in Dumas, TX, with and without Weather Responsive Signal Timings.....	64
Figure 29. Site Location – Burleson, TX.....	65
Figure 30. Location of Signalized Intersections – Burleson, TX.....	66
Figure 31. Road Surface Condition Monitoring and Weather Monitoring Station Deployed on SH 174 in Burleson, TX.....	67
Figure 32. Average Travel Time – SH 174, Burleson, TX.....	69
Figure 33. Average Approach Delay – SH 174, Burleson, TX.....	70
Figure 34. Average Stop Delay – SH 174, Burleson, TX.....	71
Figure 35. Average Number of Stops – SH 174, Burleson, TX.....	72
Figure 36. Site Location – NASA Road 1, Nassau Bay, TX.....	73

Figure 37. Location of Signalized Intersections – NASA Road 1, Nassau Bay, TX.....	74
Figure 38. Average Travel Time – NASA Road 1 in Nassau Bay, TX.....	76
Figure 39. Average Approach Delay – NASA Road 1 in Nassau Bay, TX.	77
Figure 40. Average Stop Delay – NASA Road 1 in Nassau Bay, TX.....	78
Figure 41. Average Number of Stops – NASA Road 1 in Nassau Bay, TX.	79
Figure 42. Maximum Queue Lengths – NASA Road 1 in Nassau Bay, TX.	80
Figure 43. Queue Stops – NASA Road 1 in Nassau Bay, TX.	81
Figure 44. Image of Hurricane Evacuation prior to Hurricane Rita.	87
Figure 45. Washington, D.C., Proposed Evacuation Framework.	90
Figure 46. Pasadena Study Area.	92
Figure 47. I-10 Freeway Responsive System Map.	95
Figure 48. Freeway Responsive System Framework.....	96
Figure 49. Illustration of Freeway Travel Speed Deterioration.....	97
Figure 50. Image of Contact Closures and Radio.	97

LIST OF TABLES

	Page
Table 1. Number of Stations with Monthly Weather Summary Data in Texas (2010–2014).	8
Table 2. Monthly Average Minimum Temperature (Fahrenheit).	10
Table 3. Monthly Average Temperature (Fahrenheit).	11
Table 4. Average Maximum Temperature (Fahrenheit).	12
Table 5. Number Days in Month with Minimum Temperature Less or Equal to 32.0°F.	13
Table 6. Number of Days in Month with Greater or Equal to 0.1 Inch of Precipitation.	14
Table 7. Number of Days in Month with Greater or Equal to 0.5 Inch of Precipitation.	15
Table 8. Number of Days in Month with Greater or Equal to 1.0 Inch of Precipitation.	16
Table 9. Extreme Maximum Daily Precipitation Total within Month (Inches).	17
Table 10. Average Total Precipitation Amount by Month (Inches).	18
Table 11. Maximum and Total Snowfall Amount by Month.	19
Table 12. Potential Impacts of Severe Weather Events on Signal Operations.	23
Table 13. Typical ESS Sensors (2).	29
Table 14. Tower-Mounted Sensors.	33
Table 15. Components of WRTM System at the Selected Sites.	47
Table 16. Timing Plan Selection Scheme.	52
Table 17. Climatology Data for Dumas, TX.	59
Table 18. Climatology Data for Burleson, TX.	67
Table 19. Climatology Data for Dickinson, TX – Located near NASA Road 1.	74
Table 20. Weather-Related Roadway and Traffic Operations Impacts.	102
Table 21. Weather-Related Signal Timing Impacts.	105
Table 22. Weather-Related Reductions in Free Flow Speeds.	106
Table 23. Weather-Related Reductions in Saturation Flow Rates.	107
Table 24. Suggested Minimum Green Values to Satisfy Driver Expectancy.	109

CHAPTER 1. INTRODUCTION

Weather can have a significant impact on traffic safety and operations. Weather can affect driver behavior, vehicle performance, pavement friction, and roadway infrastructure. This, in turn, can lead to increased vehicular crashes, reduced roadway capacities, and lost productivity.

Nationally, approximately 22 percent of all crashes occur during adverse weather condition (i.e., rain, sleet, snow, fog, severe crosswinds). On average, nearly 6000 fatalities and 445,000 injuries nationally are due to weather-related crashes. The vast majority of weather-related crashes occur on wet pavement (73 percent of all weather-related crashes) and during rainfall events (46 percent). Winter weather conditions, such as snow, ice, and sleet, also rank high as contributing factors in many crashes (*1*).

Weather can also have a significant impact on both mobility and productivity. In particular, weather can impact travels speeds, stopping distances, startup lost times—all factors that contribute heavily in developing robust traffic signal timings. Past research has shown that speeds on arterial streets drop between 10 to 25 percent when the pavement is wet, and between 30 to 40 percent when snow and/or ice are present. Weather conditions can also impact arterial traffic volumes and saturation flow rate (*1*).

Most traffic management agencies develop timing plans assuming ideal weather conditions (i.e., good pavement frictions, travel speeds at or near the speed limit, ideal start-up lost times). Few agencies, even in northern climates, alter their signal timing plans to account for how weather impacts traffic performance and driver behavior. As a result, a mismatch exists between assumed conditions to develop signal timing strategies and what actually exist in the field. This can further exacerbate performance issues at traffic signals. Until recently, public agencies did not have reliable and affordable technologies for monitoring weather conditions (and their effect on traffic operations) on arterial streets. Another possible reason why agencies do not adjust their signal timing plans during adverse weather conditions could be a lack of good guidance on when, where, why, and how to deploy weather responsive traffic signal operations. This project attempted to provide insight into the types of technologies to deploy at signalized intersections for monitoring weather conditions at signalized intersection and how they can be used to implement weather responsive traffic signal timing strategies.

PROJECT OBJECTIVES

The goal of this research project was to provide the Texas Department of Transportation (TxDOT) with feasible, implementable guidelines for designing and deploying special traffic signal timing plans for inclement weather conditions. The specific objectives of this project were:

- Quantify the degree to which weather impacts traffic operations at signalized intersections.
- Identify appropriate strategies for modifying traffic signal operations during inclement weather events.
- Establish criteria for deploying weather responsive traffic signal operations.
- Develop architectural framework for deploying weather monitoring devices to support traffic signal operations.
- Provide guidelines for operating traffic signal systems for different types of weather events.
- Develop training materials to assist TxDOT personnel in developing and deploying weather responsive traffic signal timings for their districts.

ORGANIZATION OF REPORT

This report is divided into a total of eight chapters. The first chapter provides an introduction into the purpose of this research. The second chapter of this report provides a summary of the perception of how weather impacts traffic operations in select TxDOT districts. In Chapter 3, the research team provides a review and critique of weather monitoring equipment to support weather responsive traffic signal operations. Chapter 4 describes a system architecture for supporting weather responsive traffic signal operations. Chapter 5 provides a summary of field and simulation studies performed in three corridors in Texas. Chapter 6 provides a review of signal timing strategies and practices used by agencies during large-scale weather evacuations, such as hurricanes. Chapter 7 provides guidelines for assisting agencies in deploy weather responsive traffic signal timing strategies. This final chapter is intended to be incorporated into as an appendix in TxDOT's current *Traffic Signal Timing Handbook*.

CHAPTER 2. WEATHER IMPACTS IN SELECT TXDOT DISTRICTS

This chapter identifies the types of weather conditions and frequency of the weather events by TxDOT region. The goal was to identify various roadway and/or visibility conditions that these regions encounter and which of them can be mitigated using the results of this project.

CHARACTERIZATION OF WEATHER IMPACTS IN SELECT TXDOT DISTRICTS

The Texas A&M Transportation Institute (TTI) team contacted selected districts to discuss potential study sites. In discussing the project with each district, the TTI team asked each district to provide information on the following:

- The types and frequency of weather occurring at the location (site).
- The willingness of the district to participate in the study.
- The suitability of the location to install weather monitoring equipment.
- The volume and type of traffic at the location.
- The management objectives of the district to operate the signal during inclement weather.

This section provides a summary of those discussions.

Abilene District

The most severe weather events in the Abilene District are rain and ice. The district also experiences high wind events occasionally. These events generally do not have a severe impact on traffic signal operations in the district. The district primarily uses video detection systems at their signalized intersections; however, heavy rain and snow events affect the effectiveness of these systems. Most of the weather-related issues have been solved by changing the detection system to a radar-based system.

Amarillo District

In the Amarillo District, intersection operations are impacted by snow, ice, and high wind events. Usually, the district will have two to three severe snow storms that drop enough snow to cause minor accumulations (less than 2 inches or so). Usually, snow and ice accumulations occur in late December and early January. These accumulations are usually enough to impact traffic flow for up to a day or so. The district does have an aggressive snow removal policy with most major facilities receiving regular treatments and plowing.

Atlanta District

In the Atlanta District, the most severe weather events are rain and ice. One potential intersection in the district where weather responsive signal timing may be appropriate is the US-59/FM 980 intersection. This intersection is located just south of a flyover, which has a weather station

installed. During severe icy conditions, the flyover will be closed. It is possible that this weather station can also be used to trigger a weather responsive signal timing at this intersection.

Austin District

During the winter months, icing is the most significant weather event in the Austin District with approximately two to three icing events occurring each year. Most of the time, these events do not last for a long duration (usually less than a day), but can have significant impacts on traffic flow. Rain events can also be significant in the Austin District. The Austin District has several low water crossings that can flood during rain. Usually these events occur in late spring (April and May) and to a lesser extent in late fall (October and November).

Beaumont District

The Beaumont District is located in the southeast portion of Texas, adjacent to the Louisiana border and the Gulf of Mexico. Because of its proximity to the Gulf of Mexico, rain and fog are the most significant weather events that impact this district. Significant rainfall events occur during June and July. This district is also experiences hurricanes during late summer and early fall.

Brownwood District

The Brownwood District operates 63 traffic signals in the district. Over the last few years, ice events have been the most significant weather events occurring in the district. The district also experiences fog in the morning several days during the year. A significant number of intersections in the district use video detection. The video detection units have the capability to detect fog and can automatically place recalls on all phases at the intersection during these times.

Bryan District

The Bryan District does not have issues related to severe weather at their signalized intersections. Because the impacts of severe weather are relatively minor, the district does not implement any weather responsive traffic signal operations during adverse weather. The district expressed safety concern associated with the high speed approaches that become slippery when it rains after a long spell of dry weather.

Childress District

The Childress District is located in north central part of Texas, adjacent to the panhandle and the Oklahoma border. This district is impacted by winter weather events, receiving one to two snow events annually. Icing is also an issue in the district.

Dallas District

The Dallas District operates a significant number of traffic signals, and weather events can significantly disrupt traffic flow in the district. The district experiences snow and icing conditions at least several times each winter, which can impact operations up to a day during these events. The district also experiences several significant thunderstorm and tornado events annually. These thunderstorm events can lead to significant rainfalls, that cause localized flooding, and damage because of high winds and hail.

El Paso District

In the El Paso District, high winds and dust storm are the most severe weather events. These events primarily occur in the spring and cause the signal heads and video detection systems to go out of alignment. The district currently does not have any weather monitoring system deployed.

The district indicated that they were willing to participate in the study and suggested at least one possible study locations—I-10 at FM 1281 (Horizon Blvd.). This intersection is a high volume intersection with high truck traffic.

Fort Worth District

The Fort Worth District operates over 400 traffic signals and maintains communications to a subset of these locations. The district experiences snow and icing conditions at least several times each winter, which can impact operations up to a day during these events. Local flooding and tornados also occur in the district. These events are generally destructive to equipment, but generally do not effect operations during the event. One potential strategy to consider might include going to flashing operations during icy conditions. During such conditions, drivers may not want to slow down or stop unless they perceive a need to do so. Flashing operations may facilitate what they are already doing.

Currently, the district does not operate any weather stations, although they did report operating some fog-monitoring stations. The City of Fort Worth has deployed weather monitoring stations at select locations within the city.

The Fort Worth District provided field sites for testing weather-related traffic signal operations. The district's objectives were to maintain the appropriate balance between traffic operations and safety during inclement weather events. The district has a number of locations that can provide different amounts of traffic demand for the field studies. The district provided TTI with a list of potential study locations for consideration in the next few weeks.

Laredo District

The Laredo District indicated that severe weather events generally do not have an impact on traffic signal operations. The most severe weather events in the Laredo District are rain. But these events have not prompted the district to make any changes in traffic signal operations.

Lubbock District

In the Lubbock District, intersection operations are impacted by snow, ice, and high wind events. The district primarily uses video detection systems at their signalized intersections as stop bar detectors. During severe winter events, the lenses on the video camera are covered by snow or ice. When this occurs, the district will place phase recalls on those approaches impacted by snow and ice to avoid skipping some phases. Recently, the district has replaced many of their video detection systems with radar-based detection systems. The effects of most weather-related events have been alleviated by changing detection type to radar-based detection.

Lufkin District

The Lufkin District did not report any regular concerns or issues associated with operating traffic signals during inclement weather events. Fog associated with weather fronts is their most significant weather issue in the district. During these events, traffic signals may be placed in recall mode if conditions are severe enough or anticipated to last a significant duration. The Lufkin District also reported that no weather stations have been deployed in the district.

Odessa District

Heavy rains and thunderstorms with flash flooding are the most likely severe weather events that occur in the district. The district can also experience occasional ice storms during the winter, but the impacts of these events are generally not long lasting. Severe weather events are generally not an issue on traffic signal operations in the district.

Paris District

Between all agencies in the district, there are approximately 100 traffic signals in operation in the district. The most significant weather events in the district generally include rain during spring and fog, sleet, and snow during the winter months. Generally sleet and snow do not persist long enough to cause continuing operational problems. The general perception in the district is that they do not see enough significant or sustained weather events to justify using weather-response signal timing at this time. Currently, the district does not operate any weather sensing equipment.

Pharr District

The Pharr District is located in southern Texas, near the border with Mexico. Rain and hurricane events tend to be the events that impact traffic operations. Currently, the district does not operate any weather sensing equipment.

San Angelo District

Heavy rains and thunderstorms with flash flooding are the most likely severe weather events in the district. However, the district indicated that severe weather events are generally not an issue on traffic signal operations in the district. There does not appear to be any appropriate study locations in the district.

Tyler District

In the Tyler District, rain is the most frequent/regular weather event; however, occasional ice and fog conditions do exist. Rain events occur mostly in the spring. The district wanted the project will quantify the benefits of doing weather-responsive traffic signal operations.

Wichita Falls District

In the Wichita Falls District, snow and ice are the main weather events that impact traffic operations. Normally, the district receives only about 2–3 inches of snow per year and usually it does not remain on the ground for more than 2 days at a time, even if multiple events occur in a short period of time. Generally, when severe weather is possible, traffic demands and travel speeds drop substantially as people stay home to avoid traveling in severe weather.

Currently, the district uses mostly video detection at their traffic signals and has not had any specific problems during inclement weather conditions. The Wichita Falls District is primarily a rural district with several small (5–6-signal) signal systems, so the impact may not be as pronounced as that in larger districts or with other rural districts with more severe and prolonged bad weather events (such Amarillo).

Waco District

Most the district's weather-related events are rain. The district experiences one or two ice events per year; however, the duration of most of these events does not last very long. Most of the weather-related issues have been solved by changing detection type.

Yoakum District

Fog is the biggest weather-related issue in the Yoakum District. Fog events have created operational issues with video detection systems. Most of the weather-related issues experienced by the district have been solved by changing the video detection system to a radar-based system.

ASSESSMENT OF WEATHER EVENTS IN EACH DISTRICT

The research team obtained monthly summaries of the 2010–2014 Texas weather data from the Global Historical Climatology Network (GHCN) database. The GHCN database is the world’s largest collection of daily climatological data sets with a total of 1.4 billion data values. It combines records from over 40 million meteorological stations that are distributed across all continents. The GHCN Monthly Summaries used in this project contain historical monthly temperature, precipitation, and snow records data derived from the GHCN-Daily database. It includes 18 meteorological elements including temperature (monthly means and extremes), precipitation (monthly totals, extremes, and number of days when certain thresholds are met), snowfall, and maximum snow depth.

The Texas data set includes weather data for a total of 2918 weather stations. However, several of them do not have data for every month of the last five years that we studied. Table 1 shows the number of weather stations with useful weather data in each month during the period of January 2010 through December 2014.

Table 1. Number of Stations with Monthly Weather Summary Data in Texas (2010–2014).

Year	Jan	Feb	Mar	Apr	May	Jun	Jul	Aug	Sep	Oct	Nov	Dec
2010	1629	1632	1638	1664	1684	1718	1721	1649	1730	1614	1653	1622
2011	1706	1623	1610	1610	1735	1768	1713	1711	1780	1801	1818	1813
2012	1829	1840	1875	1839	1931	1902	1978	1965	1993	1953	1824	1871
2013	1967	1929	1954	2103	2142	2103	2110	2092	2148	2137	2080	2004
2014	1924	1941	1993	2027	2116	2081	2068	2035	2075	2030	2046	1967

From these weather stations, researchers considered only those that are located in the vicinity of selected major population centers with significant numbers of signalized intersections that may be affected by inclement weather. Researchers used all available data from 324 weather stations located nearby the following 24 cities: Abilene, Amarillo, Atlanta, Austin, Beaumont, Brownwood, Bryan, Childress, Corpus Christi, Dallas, El Paso, Fort Worth, Houston, Laredo, Lubbock, Lufkin, Odessa, Paris, Pharr, San Antonio, Tyler, Waco, Wichita Falls, and Yoakum.

To characterize climatic and weather conditions at each of these cities, researchers calculated the following monthly temperature and precipitation related weather statistics from all available data during the period of January 2010 through December 2014:

- Temperature-related weather characteristics.
 - Number of days with minimum temperature less than or equal to 32.0°F.
 - Monthly mean minimum temperature (Celsius).
 - Monthly mean temperature (Celsius).

- Precipitation-related weather characteristics.
 - Number of days with greater than or equal to 0.1, 0.5, and 1.0 inch of precipitation.
 - Extreme maximum daily precipitation (mm).
 - Total precipitation amount (mm).
 - Maximum snow depth (mm).
 - Total snow fall amount (mm).

Table 5 through Table 11 show the results. Each value in all tables is the average of all data available for the specific month (column) from all available stations within or nearby the specific city (row) during the period of 2010–2014. Temperature statistics are given in Table 2–Table 5, and precipitation statistics are given in Table 6 through Table 11.

These results and findings from the interviews of various TxDOT districts helped the research team identify potential sites where weather responsive signal timing strategies may provide measurable benefit

Temperatures

Table 2 through Table 4 show the average minimum, average, and maximum temperatures by month for select Texas cities. The tables show that January and February tend to be the coldest months in Texas with the average low temperature hovering close to the freezing mark (32° F), and the average high temperature during these months to be close to 58°F.

Table 5 show the average number of days in each month where the minimum temperature was less than or equal to 32°F. The table shows that the Panhandle districts (Amarillo, Lubbock, Childress, and Wichita Falls) experience the most number of days where the low temperature was less than 32°. During the evaluation period, Amarillo averaged over 100 days per year with temperatures at or below freezing. Both Childress and Lubbock experienced over 80 days per year with temperatures at or below freezing, while Wichita Falls and Brownwood experienced over 60 days per year with a low temperature at or below freezing. Laredo, Corpus Christi, Houston, and Yoakum all experienced less than 20 days per year where the low temperature was at or below freezing.

Table 2. Monthly Average Minimum Temperature (Fahrenheit).

City	Monthly Average Minimum Temperature (2010–2014)											
	Jan	Feb	Mar	Apr	May	Jun	Jul	Aug	Sep	Oct	Nov	Dec
Abilene	34	34	45	54	61	72	74	74	65	54	43	36
Amarillo	-	-	-	-	-	-	-	-	-	-	-	-
Atlanta	36	36	43	52	61	70	72	72	65	52	41	36
Austin	38	41	49	58	65	72	74	74	68	58	47	41
Beaumont	41	45	52	59	67	74	76	76	70	59	49	45
Brownwood	34	36	41	52	61	70	72	74	65	54	40	36
Bryan	-	-	-	-	-	-	-	-	-	-	-	-
Childress	-	-	-	-	-	-	-	-	-	-	-	-
Corpus Christi	49	50	58	67	72	77	77	77	76	67	56	50
Dallas	38	40	49	58	65	76	77	79	70	58	47	40
El Paso	34	36	43	52	58	72	72	70	61	54	40	34
Fort Worth	36	38	47	56	63	74	76	77	68	56	45	40
Houston	43	47	54	61	68	76	76	77	72	61	50	47
Laredo	47	50	58	67	70	77	77	79	74	67	56	49
Lubbock	-	-	-	-	-	-	-	-	-	-	-	-
Lufkin	38	40	47	56	63	72	74	74	67	54	43	40
Odessa	34	36	45	54	61	72	72	72	65	54	41	36
Paris	36	36	45	54	63	74	76	77	68	56	43	38
Pharr	-	-	-	-	-	-	-	-	-	-	-	-
San Antonio	40	41	49	58	65	74	74	76	68	58	47	41
Tyler	36	40	47	56	63	74	74	76	68	56	45	40
Waco	36	38	47	56	63	74	76	77	68	56	45	40
Wichita Falls	34	36	41	52	61	72	74	74	65	52	40	34
Yoakum	41	45	50	59	67	74	74	74	70	59	50	45

Table 3. Monthly Average Temperature (Fahrenheit).

City	Monthly Average Temperature (2010–2014)											
	Jan	Feb	Mar	Apr	May	Jun	Jul	Aug	Sep	Oct	Nov	Dec
Abilene	45	47	58	67	74	83	85	86	77	67	56	47
Amarillo	38	38	50	59	68	79	81	81	72	59	47	40
Atlanta	43	47	56	65	72	83	83	86	79	65	54	47
Austin	49	52	61	70	76	83	85	86	81	70	59	52
Beaumont	52	54	61	70	76	83	83	85	81	70	59	54
Brownwood	45	49	58	68	74	85	86	88	79	68	56	49
Bryan	-	-	-	-	-	-	-	-	-	-	-	-
Childress	41	41	54	63	72	83	85	85	76	65	52	43
Corpus Christi	58	59	67	76	79	85	86	86	83	76	67	61
Dallas	47	49	59	68	76	85	88	90	81	70	58	50
El Paso	45	47	59	68	74	86	83	85	76	68	54	47
Fort Worth	47	49	58	67	74	85	86	88	81	68	58	49
Houston	52	56	63	70	77	85	85	86	81	72	61	58
Laredo	58	61	70	79	83	88	88	92	85	77	67	59
Lubbock	41	43	54	63	72	81	81	81	74	63	50	43
Lufkin	49	50	59	68	74	83	83	86	79	68	58	50
Odessa	45	49	59	68	74	85	83	85	76	67	54	47
Paris	43	45	56	65	74	85	86	88	79	67	54	45
Pharr	-	-	-	-	-	-	-	-	-	-	-	-
San Antonio	50	52	63	70	77	85	86	88	81	70	59	52
Tyler	47	50	59	68	76	83	85	86	79	68	56	50
Waco	47	50	58	68	76	85	86	88	81	68	58	50
Wichita Falls	43	45	56	65	74	85	86	86	77	67	52	43
Yoakum	52	56	63	70	77	83	85	86	81	72	61	56

Table 4. Average Maximum Temperature (Fahrenheit).

City	Monthly Average Maximum Temperature (2010–2014)											
	Jan	Feb	Mar	Apr	May	Jun	Jul	Aug	Sep	Oct	Nov	Dec
Abilene	56	59	72	81	88	95	97	101	90	79	68	58
Amarillo	52	50	67	76	83	94	92	94	86	76	63	52
Atlanta	56	58	68	79	85	94	95	99	92	79	67	58
Austin	61	65	74	81	86	95	95	99	92	83	70	63
Beaumont	61	63	72	79	86	92	92	95	90	83	72	65
Brownwood	61	61	74	83	88	97	99	103	94	83	70	61
Bryan	-	-	-	-	-	-	-	-	-	-	-	-
Childress	54	54	68	77	86	95	95	99	88	79	65	54
Corpus Christi	67	68	76	83	86	94	94	95	92	86	76	70
Dallas	58	59	70	79	86	95	97	101	92	81	68	59
El Paso	59	61	74	81	88	101	95	97	88	83	68	59
Fort Worth	58	58	70	79	85	95	97	101	92	81	68	58
Houston	63	65	74	81	86	94	94	95	92	83	72	67
Laredo	68	72	83	90	94	101	99	103	95	90	77	70
Lubbock	56	58	70	79	86	94	92	94	85	77	65	56
Lufkin	61	61	72	79	86	94	94	97	92	81	68	61
Odessa	59	61	74	83	88	97	94	97	86	79	67	58
Paris	54	54	67	76	85	94	97	99	92	79	65	54
Pharr	-	-	-	-	-	-	-	-	-	-	-	-
San Antonio	63	65	76	85	88	95	97	101	92	83	72	65
Tyler	58	59	70	79	86	94	95	97	90	79	67	59
Waco	59	61	70	79	86	94	95	99	92	81	70	61
Wichita Falls	56	56	68	77	86	97	97	101	90	79	67	54
Yoakum	63	65	74	81	86	94	94	97	92	85	72	67

Table 5. Number Days in Month with Minimum Temperature Less or Equal to 32.0°F.

City	Monthly Average (2010–2014)											
	Jan	Feb	Mar	Apr	May	Jun	Jul	Aug	Sep	Oct	Nov	Dec
Abilene	16	12	5	1	0	0	0	0	0	1	8	14
Amarillo	28	23	12	4	0	0	0	0	0	2	15	24
Atlanta	18	13	5	0	0	0	0	0	0	0	8	13
Austin	9	7	2	0	0	0	0	0	0	0	3	8
Beaumont	6	4	1	0	0	0	0	0	0	0	1	4
Brownwood	20	14	6	0	0	0	0	0	0	1	9	15
Bryan	-	-	-	-	-	-	-	-	-	-	-	-
Childress	24	19	8	2	0	0	0	0	0	1	9	19
Corpus Christi	1	2	0	0	0	0	0	0	0	0	0	1
Dallas	11	8	2	0	0	0	0	0	0	0	2	8
El Paso	18	9	3	1	1	0	0	0	0	1	6	13
Fort Worth	14	9	3	0	0	0	0	0	0	0	5	10
Houston	5	3	1	0	0	0	0	0	0	0	1	3
Laredo	2	2	0	0	0	0	0	0	0	0	0	1
Lubbock	25	16	9	3	0	0	0	0	0	1	10	19
Lufkin	14	8	4	0	0	0	0	0	0	0	6	9
Odessa	17	10	3	1	0	0	0	0	0	0	6	13
Paris	16	12	4	0	0	0	0	0	0	0	5	13
Pharr	-	-	-	-	-	-	-	-	-	-	-	-
San Antonio	10	8	3	0	0	0	0	0	0	0	3	8
Tyler	13	8	3	0	0	0	0	0	0	0	3	8
Waco	14	9	3	0	0	0	0	0	0	0	4	10
Wichita Falls	20	16	6	1	0	0	0	0	0	0	8	16
Yoakum	7	4	2	0	0	0	0	0	0	0	1	5

Precipitation

Table 6 through Table 11 summarize the precipitation-related events occurring in each district. Table 6 shows that most districts (with the exception of El Paso) experience, on average, at least one day per month with 0.1 inches or more precipitation. In most situations, this is rain. Table 7 shows that those districts located closer to the Gulf of Mexico (Beaumont, Corpus Christi, Houston, and Yoakum) tend to have more days per month that experience 0.5 or more inches of precipitation. The Beaumont and Houston Districts can expect at least one day per month with 1 inch or more precipitation.

Table 6. Number of Days in Month with Greater or Equal to 0.1 Inch of Precipitation.

City	Number of Days \geq 0.1 inch of Precipitation (2010–2014)											
	Jan	Feb	Mar	Apr	May	Jun	Jul	Aug	Sep	Oct	Nov	Dec
Abilene	2	2	2	3	4	4	3	2	3	2	1	2
Amarillo	1	3	2	2	3	4	3	3	4	2	1	2
Atlanta	6	6	4	5	5	4	4	3	3	4	5	6
Austin	3	3	3	2	4	2	4	1	5	3	3	3
Beaumont	5	6	4	3	3	6	9	5	6	3	4	5
Brownwood	2	4	3	2	4	3	3	3	3	2	2	3
Bryan	3	4	3	3	4	2	3	3	4	5	5	3
Childress	1	3	2	2	4	4	4	3	5	2	2	2
Corpus Christi	3	3	2	2	2	3	3	2	7	2	3	2
Dallas	3	4	3	4	5	4	3	3	3	4	3	4
El Paso	0	0	1	0	0	0	4	4	4	1	0	1
Fort Worth	3	3	2	4	5	4	2	3	3	3	2	3
Houston	4	5	4	2	3	4	7	4	5	3	5	4
Laredo	2	2	1	1	2	1	3	1	4	1	1	2
Lubbock	1	2	1	2	3	4	3	2	4	2	1	2
Lufkin	5	6	5	3	5	4	6	3	4	3	5	5
Odessa	1	1	1	1	2	1	4	1	4	1	1	1
Paris	4	5	4	7	5	5	6	2	3	4	4	5
Pharr	-	-	-	-	-	-	-	-	-	-	-	-
San Antonio	2	2	2	2	4	3	3	1	4	2	2	2
Tyler	4	6	4	3	5	5	5	2	3	5	4	6
Waco	3	4	4	3	4	3	3	2	4	3	3	4
Wichita Falls	1	3	3	3	3	3	3	3	4	3	2	3
Yoakum	4	4	4	2	3	3	5	2	6	2	3	3

Table 7. Number of Days in Month with Greater or Equal to 0.5 Inch of Precipitation.

City	Number of Days \geq 0.5 inch of Precipitation (2010–2014)											
	Jan	Feb	Mar	Apr	May	Jun	Jul	Aug	Sep	Oct	Nov	Dec
Abilene	1	1	1	1	2	2	2	1	2	1	0	0
Amarillo	0	0	0	1	1	2	1	1	2	1	0	0
Atlanta	2	2	2	3	3	2	2	1	1	2	2	3
Austin	1	0	1	1	2	1	2	0	3	1	2	1
Beaumont	2	3	2	1	2	3	4	2	3	2	2	2
Brownwood	2	1	1	1	2	2	1	1	2	1	1	1
Bryan	2	1	1	2	3	1	2	1	2	2	3	1
Childress	0	0	0	1	1	2	1	2	1	1	1	0
Corpus Christi	1	1	0	1	1	1	1	1	4	1	1	0
Dallas	1	1	1	2	2	2	1	1	2	2	1	2
El Paso	0	0	0	0	0	0	1	1	2	0	0	0
Fort Worth	2	1	1	2	2	2	1	1	2	2	1	2
Houston	2	2	2	1	2	2	3	1	3	2	2	2
Laredo	1	0	1	1	1	1	1	0	2	0	0	1
Lubbock	1	0	0	1	1	2	1	1	2	1	0	0
Lufkin	3	2	2	2	2	2	3	1	2	2	3	2
Odessa	0	0	0	0	1	1	1	0	1	0	0	0
Paris	2	1	3	3	3	1	2	1	2	2	2	2
Pharr	-	-	-	-	-	-	-	-	-	-	-	-
San Antonio	1	1	1	1	3	1	1	0	2	1	1	0
Tyler	2	2	3	1	3	3	2	1	2	3	2	2
Waco	2	1	1	1	2	2	2	1	2	2	2	1
Wichita Falls	0	1	1	1	2	2	1	1	2	1	1	1
Yoakum	2	1	1	1	2	1	3	1	4	1	1	1

Table 8. Number of Days in Month with Greater or Equal to 1.0 Inch of Precipitation.

City	Number of Days \geq 1.0 inch of Precipitation (2010–2014)											
	Jan	Feb	Mar	Apr	May	Jun	Jul	Aug	Sep	Oct	Nov	Dec
Abilene	0	0	0	0	0	1	1	0	1	0	0	0
Amarillo	0	0	0	0	1	0	0	0	1	0	0	0
Atlanta	0	1	1	1	2	0	1	0	1	1	1	1
Austin	1	0	0	0	2	0	1	0	2	1	1	0
Beaumont	1	1	1	1	1	1	3	1	2	1	1	1
Brownwood	1	0	0	0	1	1	1	0	1	1	0	1
Bryan	1	0	0	0	3	1	1	0	1	2	1	0
Childress	0	0	0	1	1	1	0	1	0	0	0	0
Corpus Christi	1	0	0	0	1	1	1	0	2	1	0	0
Dallas	1	0	1	1	1	1	0	1	1	0	0	1
El Paso	0	0	0	0	0	0	0	0	1	0	0	0
Fort Worth	1	0	1	1	1	1	0	0	1	1	0	1
Houston	1	1	1	1	1	1	2	1	1	1	1	1
Laredo	0	0	0	0	1	0	1	0	1	0	0	0
Lubbock	0	0	0	0	1	0	0	0	1	0	0	0
Lufkin	2	1	1	1	1	1	2	0	1	1	1	1
Odessa	0	0	0	0	0	0	0	0	1	0	0	0
Paris	1	0	2	1	2	1	1	0	1	1	1	1
Pharr	-	-	-	-	-	-	-	-	-	-	-	-
San Antonio	1	0	0	0	2	0	0	0	1	1	0	0
Tyler	1	1	1	1	1	1	1	0	1	2	1	1
Waco	1	0	1	0	1	1	1	0	1	1	0	0
Wichita Falls	0	0	1	1	0	1	1	0	1	0	0	0
Yoakum	1	0	1	1	2	1	2	0	2	1	0	1

Table 9 and Table 10 show the maximum daily precipitation and total precipitation amounts for most of the TxDOT districts. These figures show that southeastern and eastern districts receive significant amount of precipitation with Beaumont, Lufkin, Houston, Paris, and Tyler Districts averaging approximately 40 inches of precipitation annually. Each of these five districts average over 3 inches of precipitation per month.

Table 9. Extreme Maximum Daily Precipitation Total within Month (Inches).

City	Extreme Maximum Daily Precipitation Total (2010–2014)											
	Jan	Feb	Mar	Apr	May	Jun	Jul	Aug	Sep	Oct	Nov	Dec
Abilene	0.79	0.83	0.52	0.91	0.95	1.34	1.30	0.67	1.46	1.34	0.52	0.48
Amarillo	0.44	0.56	0.28	0.40	1.15	0.91	1.11	0.87	1.23	0.40	0.56	0.36
Atlanta	0.91	0.99	1.19	1.54	1.50	1.46	1.34	0.99	2.41	1.50	1.19	1.46
Austin	1.54	0.56	1.03	1.03	2.37	0.83	1.86	0.48	2.76	1.93	1.19	0.52
Beaumont	1.89	1.42	1.54	1.11	2.33	1.50	2.72	1.15	1.78	0.99	1.86	1.38
Brownwood	1.70	0.63	0.60	0.75	1.62	1.26	2.17	0.91	1.50	2.41	0.79	1.03
Bryan	1.66	0.40	0.48	0.95	2.64	1.89	2.68	0.71	2.25	2.21	0.95	0.83
Childress	0.44	0.44	0.32	1.26	0.95	1.86	0.99	0.99	0.63	0.79	0.87	0.40
Corpus Christi	1.30	0.87	0.40	0.67	1.26	0.99	1.03	0.52	2.37	1.11	0.71	0.36
Dallas	1.30	0.63	1.15	1.11	1.97	1.62	0.67	1.15	2.01	1.07	0.87	1.30
El Paso	0.16	0.12	0.16	0.32	0.08	0.12	0.67	0.67	1.62	0.36	0.08	0.20
Fort Worth	1.86	0.71	1.26	1.11	1.30	1.58	0.71	0.79	1.97	1.50	0.71	0.99
Houston	1.50	1.03	0.91	1.30	2.21	1.23	2.05	1.15	2.01	1.58	1.38	1.74
Laredo	0.71	0.40	0.36	0.60	1.54	0.56	1.66	0.36	1.93	1.11	0.32	0.95
Lubbock	0.48	0.48	0.56	0.95	0.71	0.87	1.03	0.83	0.99	0.79	0.48	0.36
Lufkin	1.54	1.03	1.66	1.23	1.78	2.17	2.01	1.07	2.56	1.42	1.38	1.11
Odessa	0.48	0.24	0.08	0.20	0.79	0.56	0.63	0.40	1.23	0.52	0.36	0.44
Paris	1.07	0.71	1.86	1.23	3.04	1.50	1.74	0.60	1.66	1.74	1.11	1.62
Pharr	-	-	-	-	-	-	-	-	-	-	-	-
San Antonio	1.26	0.56	0.52	0.63	2.56	0.75	0.87	0.91	2.21	1.23	0.99	0.40
Tyler	1.26	1.11	1.38	1.66	1.30	2.21	1.42	0.95	2.64	2.01	1.11	1.03
Waco	2.21	1.03	2.09	1.03	1.50	1.97	1.46	0.56	2.52	2.25	0.75	0.75
Wichita Falls	0.52	0.56	0.83	1.15	1.34	1.15	0.99	0.91	1.70	1.34	0.63	0.56
Yoakum	1.82	0.67	1.82	1.23	2.45	1.54	1.62	0.83	2.72	1.34	0.91	0.99

Table 10. Average Total Precipitation Amount by Month (Inches).

City	Monthly Average Total Precipitation (2010–2014)											
	Jan	Feb	Mar	Apr	May	Jun	Jul	Aug	Sep	Oct	Nov	Dec
Abilene	1.23	1.30	0.91	1.50	2.41	2.64	2.72	0.99	2.96	1.74	0.71	0.87
Amarillo	0.52	1.07	0.52	0.91	2.17	2.17	2.01	1.74	2.49	0.67	0.75	0.60
Atlanta	2.92	2.76	3.08	3.63	4.06	2.64	2.72	1.58	4.30	3.27	3.15	4.14
Austin	2.37	1.15	1.82	1.50	4.57	1.62	3.43	0.52	5.32	3.67	2.45	1.38
Beaumont	4.14	4.45	3.12	2.41	3.71	4.10	7.68	2.76	4.69	2.37	3.59	3.39
Brownwood	3.00	1.38	1.50	1.26	3.59	2.41	2.76	1.58	2.64	3.15	1.19	1.70
Bryan	3.12	0.99	0.87	1.50	6.07	2.29	3.43	1.26	3.75	4.53	3.12	1.74
Childress	0.52	0.95	0.67	2.01	1.78	3.35	2.17	2.17	1.70	1.38	1.15	0.71
Corpus Christi	2.25	1.78	0.79	1.23	1.78	1.86	2.21	0.75	6.78	1.97	1.54	0.79
Dallas	2.60	1.38	2.25	2.45	3.94	3.08	1.58	2.09	3.55	2.56	1.58	2.64
El Paso	0.20	0.20	0.16	0.32	0.12	0.16	1.66	1.54	3.51	0.44	0.12	0.32
Fort Worth	2.96	1.42	2.25	2.37	3.04	3.12	1.34	1.50	3.31	2.72	1.46	2.13
Houston	3.04	2.68	2.33	2.09	4.14	2.84	6.11	2.29	4.22	2.80	3.08	3.31
Laredo	0.91	0.67	0.63	1.15	2.25	0.75	2.76	0.44	3.51	1.15	0.48	1.30
Lubbock	0.60	0.83	0.83	1.50	1.70	2.09	2.13	1.42	2.52	0.99	0.63	0.56
Lufkin	3.90	3.00	3.63	2.33	3.75	3.55	4.69	1.74	4.49	2.80	3.55	3.27
Odessa	0.56	0.32	0.12	0.36	1.03	0.79	1.38	0.60	2.60	0.60	0.44	0.63
Paris	2.29	2.01	3.71	3.51	5.32	2.64	4.38	0.91	3.00	3.47	2.52	3.15
Pharr	-	-	-	-	-	-	-	-	-	-	-	-
San Antonio	2.01	1.15	0.91	1.30	5.12	1.50	1.62	1.11	4.14	1.78	1.46	0.83
Tyler	2.92	2.96	3.55	2.60	3.27	4.41	3.31	1.46	3.98	4.65	2.64	3.12
Waco	3.51	2.05	3.43	1.93	3.15	3.51	2.60	0.83	4.49	3.47	1.74	1.86
Wichita Falls	0.79	1.26	1.34	2.01	2.09	2.29	2.13	1.78	3.67	2.05	1.19	0.99
Yoakum	3.31	1.78	2.76	1.97	3.82	2.25	4.61	1.23	6.23	1.89	1.62	1.54

Table 11 provides a summary of the maximum and total amount of snowfall for the winter months. Amarillo far exceeds the rest of the state in terms of the maximum and total amount of snowfall. Childress, Lubbock, and Wichita Fall also experience high snowfall amounts compared to the rest of the state.

Table 11. Maximum and Total Snowfall Amount by Month.

City	Maximum Snow Depth (inches)						Total Snowfall Amount (inches)					
	Jan	Feb	Mar	Oct	Nov	Dec	Jan	Feb	Mar	Oct	Nov	Dec
Abilene	0.24	1.58				0.48	0.08	2.60			0.04	0.40
Amarillo	2.29	10.75	0.79	0.32	0.71	1.74	1.50	9.22	0.91	0.91	0.83	2.49
Atlanta	0.40	1.78					0.40	1.82				
Austin		0.08						0.08				
Beaumont												
Brownwood	0.48	0.79			0.24	0.40	0.60	0.67			0.12	0.16
Bryan												
Childress	0.12	2.52	0.24		2.05	0.91	0.08	4.53	0.28		1.23	0.63
Corpus Christi												
Dallas		1.23	0.20			0.40	0.04	1.38	0.28			0.20
El Paso	0.12	0.20				0.12	0.28	0.04			0.04	0.12
Fort Worth		0.63				0.12	0.04	0.75				0.16
Houston												
Laredo												
Lubbock	0.52	1.89	0.08		0.75	0.63	0.52	2.37	0.20		0.67	0.79
Lufkin	0.16	0.36					0.44	0.32				
Odessa	0.99	0.36			0.08	0.79	0.71	0.40			0.08	1.03
Paris											0.04	
Pharr												
San Antonio	0.95	0.12				0.20	0.36	0.20				0.08
Tyler	0.12	0.52	0.12			0.12	0.08	0.95	0.24			0.24
Waco		0.60						0.52				
Wichita Falls		2.41				1.07		1.66	0.12		0.04	0.75
Yoakum												

CHAPTER 3. WEATHER MONITORING EQUIPMENT TO SUPPORT WEATHER RESPONSIVE TRAFFIC SIGNAL OPERATIONS

This chapter summarizes the findings of the state-of-the-practice review of weather monitoring technologies and provides draft specification for purchasing roadway weather monitoring equipment. In this section, the TTI research team summarizes the potential impacts adverse weather can have on traffic signal operations. Researchers provides an assessment of different types of weather monitoring technologies that might be suitable for implementing weather responsive traffic signal timing plans and provide a review of recommended criteria for siting and installing weather monitoring technologies. Researchers also examine how weather information systems can be interfaced with traffic signal control systems to implement weather responsive traffic signal timing plans. Researchers then list the specification that TxDOT can use to procure the weather monitoring equipment that will be deployed in the field.. The specifications are limited to those weather monitoring systems that are necessary to support decision making related to traffic signal operations at isolated traffic signals or closed-loop signal systems and are not intended for use with other traffic management or weather monitoring needs that TxDOT may have.

POTENTIAL IMPACT OF ADVERSE WEATHER ON SIGNAL OPERATIONS

Operation of a traffic signal is directly or indirectly influenced by roadway/intersection geometry and characteristics, vehicle characteristics, human factors, traffic regulations, and traffic characteristics. Examples of these include:

- Roadway geometry: Number of approaches and their intersection angles, number of lanes on each approach, presence/lengths of turn bays, intersection width, approach grade, sight distance, etc.
- Vehicle characteristics: Acceleration and deceleration characteristics, braking distance, turning radius, etc.
- Human factors: Perception/reaction time, expectancy, visual acuity, etc.
- Traffic regulation: Approach speed limit, U-turn permission, right turn on red permission, etc.
- Traffic characteristics: Composition of vehicle types, driver age distribution, traffic volumes, and pedestrian activity.

In addition, the operation of a typical traffic signal depends on detection design and type of detection technology at the intersection (i.e., video, loops, radar) and controller settings. Combined consideration of roadway geometry, vehicle characteristics, and human abilities translates into key traffic control parameters listed below:

- Minimum phase times, which primarily depend on driver expectancy and vehicle characteristics.
- Maximum times (or splits), which depend on traffic demand, ideal saturation flow rate of vehicles, and the objective of timing (i.e., minimizing delay or stops).
- Phase gap times, which depend on prevalent speed of vehicles after queue clearance and detector design (including dilemma-zone protection at high-speed intersections).
- Yellow clearance time, which depends on prevalent vehicle speeds, approach grade, and an assumed vehicle deceleration rate. Also, driver's ability to see a signal change and react to it (i.e., stopping sight distance) is implicitly taken into consideration in selecting the length of this clearance interval.
- All-red clearance times, which depend on prevalent speed and width of intersection that a vehicle needs to clear after entering the intersection, and design vehicle length.

The routine practice of traffic/transportation agencies is to determine controller settings by assuming values of underlying factors applicable under ideal conditions combined with agency's operational objective (minimizing delay, minimizing stops, minimizing number of vehicles in the dilemma zone, or maximizing progression).

Under adverse weather conditions, however, values of underlying human factors and vehicle characteristics may change drastically, requiring different controller settings and even a change in signal timing optimization objectives. Table 12 provides examples of how various weather events may affect factors determining signal timing parameters.

As identified in Table 12, various weather events may require values of signal timing parameters different from those used under normal conditions to maintain safe and efficient signal operation. These values will need to be determined based on the severity of weather impact and intersection geometry. For instance, a weather event causing reduced visibility and slippery roads will cause the following to occur:

- Vehicle speeds to drop.
- Gaps between vehicles to increase.
- Vehicle acceleration or deceleration times to increase.

These changes may require longer clearance intervals and gap settings to execute safe driving maneuvers, and may cause operational objectives to shift from minimizing delays to minimizing stops, which in turn can be accomplished by increasing minimum and maximum phase time.

Table 12. Potential Impacts of Severe Weather Events on Signal Operations.

Weather Event/Factors Affected	Snow	Ice/Sleet	Heavy Rain	Wind	Fog/Dust	Signal Timing Parameters/ Hardware Impacted
Sight/Decision Distance (Visibility)	✓	✓	✓		✓	Clearance Intervals, Video Detection Failure
Vehicle Acceleration		✓	✓			Clearance Intervals, Gap Settings, Phase Times
Vehicle Deceleration/Braking		✓	✓			Clearance Intervals, Gap Settings, Phase Times
Reduced Prevalent Speed	✓	✓	✓	✓	✓	Clearance Intervals, Phase Times
Increased Gaps in Vehicle Stream		✓	✓	✓	✓	Phase times, Gap Settings

Many modern traffic controllers provide for multiple timing and detector plans that can be used to pre-program alternate settings of signal control parameters, which could be selected as appropriate. Automating this selection could be achieved by deployment of weather and pavement sensors to detect the severity of various weather events and built-in controller features to trigger the selection of an appropriate timing and detector plan. In some cases, more drastic actions may be required to maintain safety. Such measures may include changing signal operations to flashing green for main traffic flow directions and flashing red for other movements or even strategic closure of minor cross streets.

DESIRED CONTROLLERS FEATURES

The previous section identified a range of actions, in terms of dynamic changes in signal timing parameters, which could be taken in the event of adverse weather conditions. However, the ability to do so would be limited by features of controllers in the field. Many existing controllers used by TxDOT are limited to the following:

- The selection of an alternate maximum (max) time.
- The selection of a different preprogrammed coordination plan (cycle length, offset, phase sequence, and split). The preprogrammed plan may also alter phase options for each phase (omit phase, min recall, and max recall).

However, several brands of newer controllers also provide for the programming of, and selection from, multiple timing and detector plans. These newer controllers can be used to implement the

full range of strategies to cope with adverse weather events, including selection of different minimum times, maximum times, all-red times, and detector gap settings.

WEATHER MONITORING TECHNOLOGIES

The following section briefly summarizes the different types of weather monitoring technologies that might be suitable for deployment of weather responsive traffic signal timings.

Wind Sensors

A wind sensor determines both the speed and direction of wind movement, including wind gusts. Wind speed is typically measured with an anemometer, while direction is measured with a wind vane or wind sock.

Anemometers are typically either conventional (i.e., mechanical) sensors or sonic sensors. The conventional spinning cup sensors measure horizontal wind speed mechanically or electrically from shaft spin speed. The sonic sensors use ultrasonic sound waves to measure wind velocity. Some of these have three or four sensor arms. Two-dimensional sonic anemometers can measure both wind speed and direction, and one of the main benefits of a sonic sensor is that they lack moving parts, making them excellent for long-term installations.

Many modern wind sensors use a combined anemometer and vane called an aerovane. These use a spinning propeller to measure speed and a vane on the tail to determine direction. These are typically called propeller anemometers, and the spinning shaft of the propeller creates an electrical signal, which corresponds to a specific wind speed that is recorded. Figure 1, Figure 2, and Figure 3 illustrate different types of wind sensors.



Figure 1. Mechanical Anemometer – Wind Speed Only.



Figure 2. Sonic Anemometer – Wind Speed and Wind Direction.



Figure 3. Propeller Anemometer – Wind Speed and Wind Direction.

Precipitation Sensors

As illustrated in Figure 4 and Figure 5, precipitation sensors are used to determine the occurrence, type, intensity, and accumulation of precipitation. Rain gauges can be used to determine the occurrence and accumulation of rain. These gauges can also determine rain

intensity if they take measurements at regular time intervals. Some sensors measure volume, while others measure weight. Another type is the tipping bucket style, which measures the number of times a mechanism with a small container fills with water and tips over. Many of these devices contain heaters so that they can operate in freezing temperatures. Also, some sensors are specifically designed just to detect the onset of rain and not necessarily detecting quantity of rain. They do this by activating when water contacts a gold-plated grid sensor.



Figure 4. Radar Precipitation Sensor. Figure 5. Capacitive Transducer Sensor.

Other sensors are all inclusive in that they record information related to occurrence, type, intensity, and accumulation. These include optical presence detectors, radar detectors, and those with capacitive transducers to detect precipitation. They typically have no moving parts, and the optical and radar types determine precipitation type by measuring the speed of the precipitation.

Radiation Sensors

Multiple types of radiation can be measured. Solar radiation (i.e., sunlight) can be measured by typical sunlight sensors. Others specifically detect and measure solar radiation in the UV spectrum. These all detect the light through specialized lenses.

Visibility Sensors

Visibility can be measured either by camera systems or by optical sensors (illustrated in Figure 6). Camera systems can be set up to be either monitored by staff or by automated systems with visibility detection software. Optical sensors use an optical light sensor that can detect visibility and varying levels of atmospheric obstruction, such as fog or dust. They can operate in large ranges of temperature and humidity, and accuracy varies but can be ± 10 percent for some products. Power requirements usually are around 12 V DC, but consumption is moderate (some can draw as much as 7 to 10 W).



Figure 6. Optical Visibility Sensor.

Temperature/Dewpoint Sensors

Air temperature is measured by a probe thermometer. Most of these tend to be very lightweight and extremely low power consumption (i.e., 12 V DC, <20 mA). Accuracy varies, but some can be accurate down to $\pm 0.2^{\circ}\text{C}$. Humidity sensors can measure dewpoint and relative humidity. These often are combined with a thermometer as part of a combined sensor. Output is a relative humidity or dewpoint measurement in analog or digital formats, and the sensors can be set to trigger an alarm when thresholds are met.



Figure 7. Combination Temperature and Humidity Sensor.

Barometric Pressure Sensors

Barometric pressure is measured by a barometer, which can be either digital or analog. Similar to temperature and humidity sensors, barometers tend to be small and lightweight with lower power consumption. Accuracy depends on whether it is digital or analog, but readings can be within 0.05 percent accurate. While some barometers are standalone, many use a temperature correction to increase accuracy of the pressure reading. Several barometric sensors include a temperature measurement as well. There are products that include a temperature probe, humidity sensor, and barometric pressure sensor. This style of sensor still has the capabilities of the individual sensors (low power, small, and lightweight), but most would be digital only. There is even a product that detects road surface temperature along with these other three readings.



Figure 8. Combination Barometric Pressure, Temperature, and Humidity Sensor.

Road Surface Sensors

Road surface sensors determine the presence of snow, ice, and water on the pavement. Some may also record temperature. These measurements can be accomplished by two methods. One is to install a sensor on the roadway surface, but this can be intrusive and difficult to install and maintain. The other method is detection from a pole-mounted installation. These pole-mounted sensors use laser detection and can detect dry, wet, snow covered, ice, and black ice conditions on Portland cement concrete or asphalt concrete. Some of these can also measure surface temperature, relative humidity, and air temperature. Accuracy and sensitivity are usually very good, but the measurement area and elevation angle must be chosen properly during installation. These units use relatively low power at around 12 V DC and approximately 4 W.

Water Level and Snow Depth Sensors

Ultrasonic or acoustic sensors work by measuring the time required for an ultrasonic pulse to travel to and from a target surface. Some ultrasonic sensors use air-temperature detection to improve the accuracy of depth detection. Another type of sensor in this category measures snow-water equivalent by passively detecting the change in naturally occurring electromagnetic energy from the ground as it passes through snow cover.

GUIDELINES FOR SITING AND INSTALLING WEATHER MONITORING TECHNOLOGIES AT INTERSECTIONS

This project recommends using siting guidelines for Road Weather Information System (RWIS) Environmental Sensor Stations (ESS) developed by the Federal Highway Administration (FHWA) in partnership with the Aurora RWIS Pooled Fund Program and the American Association of State Highway and Transportation Officials Snow and Ice Cooperative Program (1). The first version of the FHWA guide, released in 2004, documented best practices in RWIS ESS deployment. The main purposes of the guidelines were to (a) provide a set of recommendations for uniform siting of sensor stations to collect all necessary data for road weather information systems, and (b) facilitate the development of a nationwide, integrated road weather observation network. In 2007, FHWA initiated a study to review and evaluate the implementation of RWIS ESS Siting Guide (2). Nine departments of transportation (DOTs) with extensive RWIS were interviewed and three of them, Michigan, New Hampshire, and Idaho, were studied in more details. Based on the lessons learned from agencies using the guide for ESS deployments, a few minor revisions to the guide were recommended. The most significant change made to this version of the Guidelines was the inclusion of an expanded metadata table. Metadata includes types of sensors, sensor locations, types and frequencies of data collected, data formats, etc., about an ESS.

The revised RWIS ESS Siting Guidelines provide recommendations for:

- Road Weather Information Requirements.
- Site selection criteria for both regional and local sites.
- Sensor selection and placement.
- Partnership between agencies involved in environmental data collection.
- Metadata elements to be maintained for all ESSs.
- Other considerations (e.g., power and communication requirements, safety, and security).

Road Weather Information Requirements

The guidelines provide general recommendations for assessing road weather information requirements. Main considerations include:

- How will the road weather information be used?
- Will the ESS measure data for site-specific conditions or a larger area?
- What types of weather/environmental data are needed?
- In case of multiple ESSs, which sites and road weather elements have priority over other sites?
- What other potential sources of weather and operational data are available?

Site Selection

ESS can be installed for local applications (i.e., collecting specific weather and/or environmental data for a bridge, short segment of a roadway or an intersection) or as part of a regional weather information system, providing data on general weather conditions for a large area or roadway network. The objective is to locate the ESS where its observations will be the most representative of the roadway segment or area of interest. Due to the many constraints that often exist, the ideal ESS location can be rarely identified. The purpose of FHWA guidelines is to help DOT planners find the best trade-off that yields a near-optimal ESS location.

Sensor Selection and Placement

An ESS may consist of various combinations of sensors that measure atmospheric, pavement soil, and water-level conditions. Table 13 lists the most common ESS sensors, and Figure 9 illustrates their typical configuration.

Table 13. Typical ESS Sensors (2).

Roadway Element	Sensor
Air Temperature	Thermometer
Water Vapor (Dewpoint or Relative Humidity)	Hygrometer
Wind Speed and Direction	Conventional and Sonic Anemometer and Wind Vane or combined sensor (Aerovane)
Pavement Temperature, Pavement Freeze Point Temperature, Pavement Condition, Pavement Chemical Concentration	Pavement Sensor
Subsurface Temperature	Subsurface Temperature Probe
Subsurface Moisture	Subsurface Moisture Probe
Precipitation Occurrence	Rain Gauge, Optical Present Weather Detector
Precipitation Type	Rain Gauge, Optical Present Weather Detector
Precipitation Intensity	Rain Gauge, Optical Present Weather Detector
Precipitation Accumulation	Rain Gauge, Optical Present Weather Detector, Hot-plate Type Precipitation Sensor
Snow Depth	Ultrasonic or Infrared Snow Depth Sensor
Visibility	Optical Visibility Sensor, Closed Circuit Television Camera
Atmospheric Pressure	Barometer
Solar Radiation	Solar Radiation Sensor
Terrestrial Radiation	Total Radiation Sensor
Water Level	Pressure Transducer, Ultrasonic Sensor, Float Gauge, or Conductance Sensor

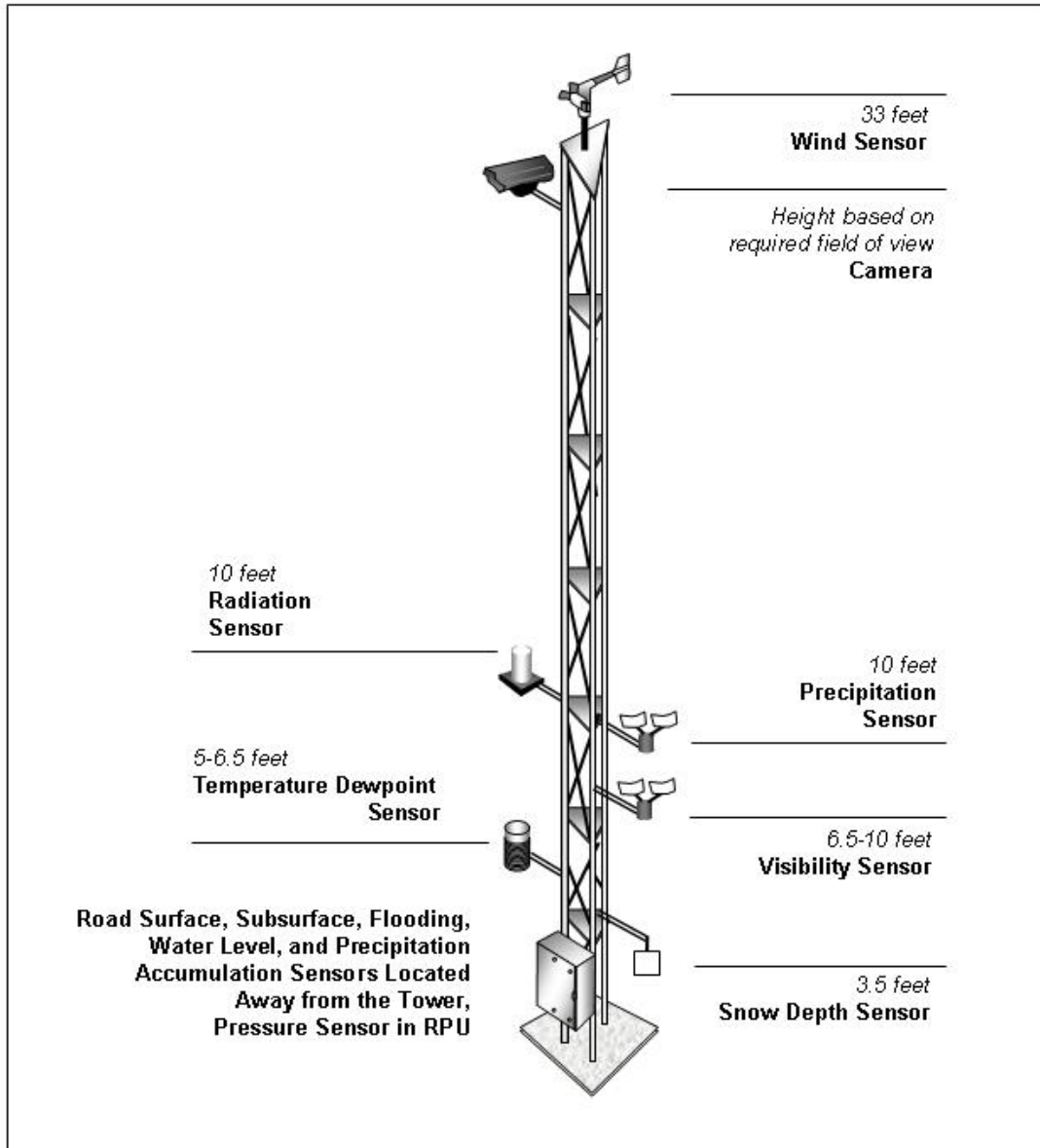

Figure 9. Typical Sensor Configuration of an Environmental Sensor Station (2).

The guidelines provide specific recommendations on the mounting locations (heights) of different sensors on the observation tower. Specifications and instructions for the deployment sensors measuring pavement temperature, and moisture and water-level are also provided.

Additional Considerations

The guidelines also list a number of criteria related to power and communication requirements, maintenance, safety, and security. It also makes recommendations on periodic siting re-evaluation and the type of metadata that needs to be maintained for each sensor.

Application of the Guide to Deploy ESS at Signalized Intersections

This section describes how the ESS Siting Guide will be used for deploying ESS for weather responsive signal operations at intersections that are selected as case study locations for the project. The steps summarized in Figure 10, and described below, will be followed in this project.

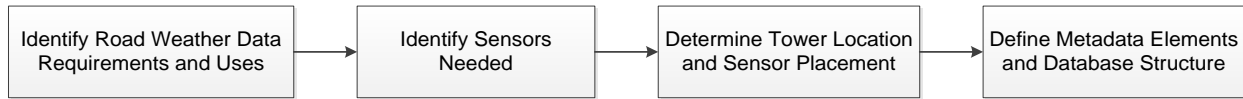

Figure 10. Steps of RWIS ESS Siting.

Identify Road Weather Data Requirements and Uses

The main purposes of deploying ESS at the intersections were monitor roadway conditions and help manage traffic during inclement weather. Site visits to the candidate study sites (signalized intersections) revealed that the typical weather-related operational and safety concerns are slippery pavement and reduced visibility conditions. Slippery pavement is caused by snow and ice (study site in Dumas/Amarillo) and/or rain (study site in Nassau Bay). Low visibility may be caused by occasional fog, heavy rain, or blowing snow.

Therefore, data on air and pavement temperature, precipitation (rain and/or snow), wind (speed and direction), and visibility are required.

Identify Sensors Needed

The sensors that may be required for collecting the road weather data identified include:

- Air temperature/dew point sensor.
- Optically based precipitation sensors (rate, type, and amount).
- Snow depth sensors.
- Visibility sensors.
- Wind speed and direction sensor (anemometer).
- Pavement temperature and pavement condition sensors.

Determine Tower Location and Sensor Placement

There are no specifications for the minimum distance the tower should be placed from the roadway to avoid the effects of traffic (e.g., heat, wind, and splash) on the accuracy of the data measured by the sensors. It is also uncertain and depends on the type of sensors and how close the tower must be to adequately represent the environment over the roadway. Towers are typically installed within a range of 30–50 ft from the edge of the paved surface, as illustrated by Figure 11.

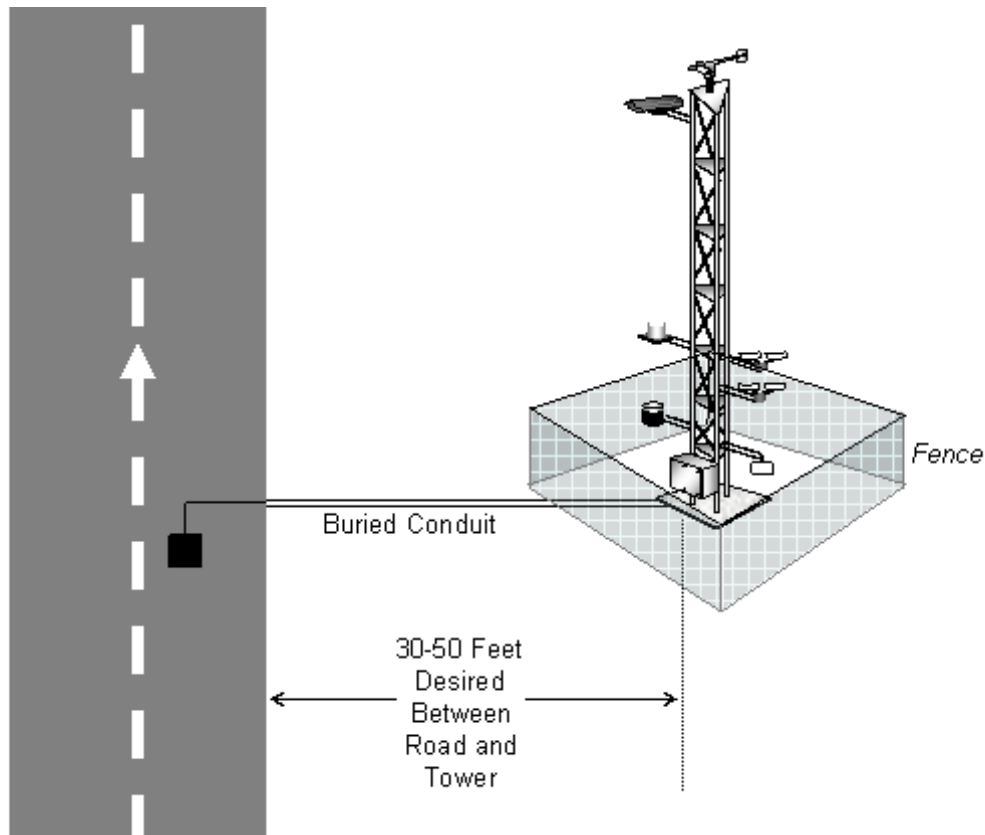

Figure 11. Tower Location Relative to Roadway.

Towers should be installed on relatively flat terrain. Their height depends on the type of sensors mounted on them. If a wind sensor is used, the tower should be tall enough to install it at a height of 33 ft (3).

Additional considerations for locating the tower:

- Verify the availability of rights-of-way.
- Identify power source options and challenges (type, access, cost).
- Identify communications options and challenges (type, capacity, frequency of access, cost).
- Other constraints and restrictions (e.g., environmental, archeological, aesthetic).

Tower position and height of the sensors on the tower should be included in the metadata file. Table 14 lists the sensors that may be required and their typical position on the ESS tower.

Table 14. Tower-Mounted Sensors.

Sensor	Mounting Recommendations
Air Temperature/Dew Point Sensor	5–6.5 ft above ground level. Where road frost is a concern, a second dew point sensor mounted closer to the pavement may help identify frost formation potential.
Optically based Precipitation Sensors (Rate, Type, and Amount)	10 ft above ground level to avoid contamination from debris.
Snow Depth Sensors	Install perpendicular to the surface at a height of approximately 3.5 ft. Sensor is based on ultrasonic or infrared emissions and sensitive to vibrations.
Visibility Sensors	6.5–10 ft above ground level to represent the eye level of drivers.
Wind Speed and Direction Sensor (anemometer)	33 ft above ground level. Obstructions to the wind flow should be avoided.

Source: (1)

Pavement Temperature and Pavement Condition Sensors

On multilane roadways, it is recommended to install several sensors in different lanes. For single sensor installation, typically the rightmost lane is selected. Ice most often forms on the road surface during the predawn and morning hours. Researchers recommend installing the pavement sensors in the rightmost lane of the approach with heaviest morning traffic.

In general, pavement sensors should be installed near the edge of the inside wheel track, as shown in Figure 12. Pavement temperatures in lane centers can be as much as 2°F higher. Therefore, placing pavement sensors in the center of a lane is not recommended.

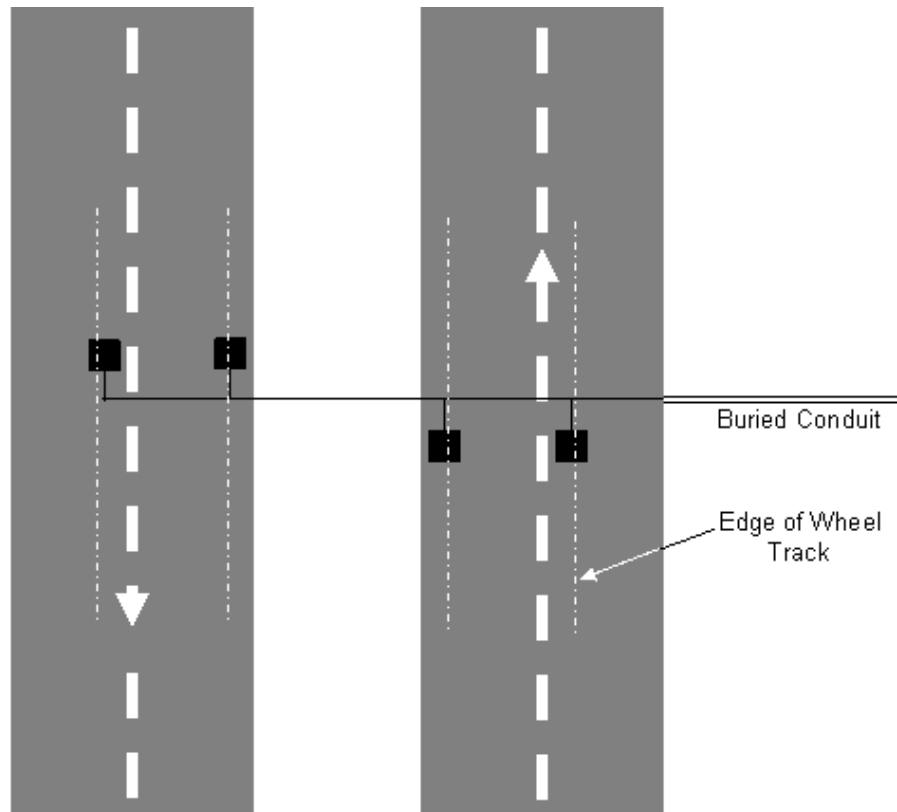

Figure 12. Pavement Sensor Placement.

USER NEEDS ASSESSMENT

This section defines the user needs and system requirements of the proposed weather monitoring system. The objective is to measure weather events that can adversely impact traffic operations at traffic signals. Based on the weather events identified by the districts, the researchers identified the following types of weather sensors to acquire the data necessary to identify adverse weather conditions that might affect traffic signal operations:

- **Visibility Sensors:** The sensors to detect any deterioration in visibility should be able to detect if visibility has decreased to a user defined threshold. Visibility can decrease due to fog, dust, rain, snow, or haze.
- **Pavement Condition Sensors:** Pavement condition sensors are intended to detect water, ice, or snow accumulations on the pavement. Snow and ice could be detected by infrared sensors. Wet pavement could be detected by resistivity.
- **Heavy rain:** Rain sensors need to detect the intensity of rain, which can impact not only pavement condition, but also visibility.

All these sensors should be able to function with a low voltage solar panel to facilitate installation at locations where 110 V AC is not available. These sensors should also be able to generate a trigger in an analog or digital format when a user defined threshold has been reached.

They should also be light weight and easy for installation on existing poles or other commonly present infrastructure. The preference is for non-intrusive sensors that do not affect traffic or require closure of lanes for installation.

POTENTIAL ARCHITECTURES

There are several factors that can affect the potential architecture for installing weather monitoring sensors for the management of adverse weather conditions at signalized intersections. These factors include:

- Sensor capabilities, including:
 - Type of weather measurements provided by the sensor. Some of the weather measurements can apply to a whole group of intersections that are part of a closed loop system and are affected by the same weather phenomena like ice, snow, and sleet. Other weather measurements might apply only to a certain small locality like visibility.
 - Ability of the user to define thresholds that can trigger weather alarms.
 - Ability of the sensor to communicate the output alarms through relays that can be used by an external system to initiate a response or communicate the weather measurements through a predefined protocol to an external system.
- The goal and purpose of the adverse weather response system including:
 - Management of a single isolated intersection.
 - Manage a series of interconnected intersections.
- Presence of a field master or a central traffic management system.

Based on the above mentioned factors, there are two potential architectures for installing weather sensors at intersections:

- Regional weather station that includes the necessary sensors to monitor the possible adverse weather conditions that can affect a certain region (visibility, road surface conditions, rain, wind, etc.).
- Local weather station at an isolated intersection to measure the adverse weather conditions that affect a specific intersection only.

Also, depending on the communication capabilities of the weather sensors used, a simple system can be designed to generate relay outputs that can trigger weather responsive actions at a local or regional level. However, if the sensors' communications capabilities can only provide messages that need to be interpreted by an external device, an intermediary intelligent device might have to be used to interpret the sensors output and trigger an alarm that can be used to initiate a response.

WEATHER STATION INTERFACE WITH THE TRAFFIC SIGNAL SYSTEM

Researchers decided to use a single weather monitoring system (consisting of all needed sensors) at each field deployment site. This section addresses decisions made about its interface with the traffic signal infrastructure at the site, which may have one of the following configurations:

- An isolated signalized intersection.
- A system of signals connected to a field master.
- A system of signal connected to a hardware (i.e., field) or central software master located at the traffic management center.

Interface with the Traffic Signal Infrastructure

Weather monitoring equipment should have the capability to generate event-specific triggers (e.g., visibility dropping below 100 ft, ice on road) to identify situations warranting specific actions. An interface device (i.e., a computer, a microcontroller) will receive this information and communicate as described below to cause any warranted changes in the traffic signal operations.

Interface with a Local Controller at an Isolated Signal

In the case of a TS-1 cabinet, the interface device needs to communicate with the controller via the special function pins on the cabinet back panel of the isolated cabinet. Inputs to the special function pins can trigger an appropriate set of preprogrammed special timings at the local intersection. Similarly, upon expiration of adverse weather conditions, these pins can be used to trigger the resumption of normal traffic signal operation. Depending on the cabinet type and controller capabilities, communication from the interface device to the controller can occur via serial communications to enhanced Bus Interface Unit (BIU) or directly to the controller via National Transportation Communications for ITS Protocol (NTCIP) messages.

Interface with a Multiple Signal System in a Closed Loop Traffic Management System

In this case, the triggers/messages from the interface device need to be communicated to the closed loop system (or central master), which will be responsible for activating an appropriate (preprogrammed) timing plan at all signals in the system. This objective can be accomplished as follows:

- Interface device connected to one selected signal controller and communicating weather event triggers as described above to activate special events.
- Special events in the controllers programmed to trigger appropriate alarms to central system.
- The central system implements an appropriate timing in all controllers in the system.

A similar set of events can be used to resume normal operation when adverse weather condition ceases to exist.

Interface with a Signal System Using a Local Field Master

In this case, the interface device needs to interface with the local master. This can be accomplished by interfacing with the special function pins on the cabinet back panel of any cabinet in the system. These special function pin can then generate an alarm, which would be transferred to the local master in the form of an alarm. The alarm can be used by the local master to initiate a series of special timing plans either to one intersection or a set of intersections for the duration of the weather event. Upon completion of the weather event, another alarm can be sent to return to normal operations.

Interface with a Signal System with Peer-to-Peer Communications

In this case, the interface device will connect to one of the local controllers via detector inputs to traffic signal cabinet to trigger desired events. Peer-to-peer communication and built-in controller capability will be used to activate the desired events in other controllers in the system.

POTENTIAL ROAD WEATHER SENSOR TECHNOLOGY PROCUREMENT SPECIFICATIONS

This section provides potential specifications for procuring the roadway visibility and roadway surface sensors that will be deployed as part of this project.

Roadway Visibility Sensor

For use in the project, roadway visibility sensors should satisfy the following requirements and specifications:

- The device must use non-intrusive into the roadway technology, and no cabling cut into the roadway or lane closures will be required for installation/testing.
- The technology must be safe for the passing motorists. Lasers, if used, must be safe for exposure to the unprotected eye.
- The sensor must provide an indication of the current visibility conditions at the site using a standard definition of visibility (e.g., visibility range).
- The sensor must provide a reading of the visibility conditions at least once per 5-minute interval.
- The sensor must provide a real-time output that is capable of sending data to a remote location via a collocated cellular data system. A simple ASCII or Hex output frame is expected. Documentation must be available to decode all data the sensor measures including definitions of units used and data ranges per data element.
- The sensor must provide one of the following physical communication interfaces:
 - RS-232.
 - RS-422.

- RS-485.
- Ethernet.
- The sensor must provide a software user interface to allow for remote monitoring, configuration, and diagnostics.
- The sensor must operate and provide expected quality of readings when mounted on roadside equipment such as overhead sign bridges, closed circuit television (CCTV) camera poles, and dynamic message sign structures. The sensor must be able to operate from at least 20 ft from the roadway.
- The sensor must fully operate with expected accuracy in all normal outdoor environmental conditions (i.e., hot, cold, heavy rain, fog, dust, smoke).

Specification for Road Condition Sensor

For use in the project, roadway condition sensors should satisfy the following requirements and specification:

- The device must use non-intrusive into the roadway technology. No cabling cut into the roadway.
- The technology must be safe for the passing motorists. Lasers, if used, must be safe for exposure to the unprotected eye.
- The sensor must provide an indication of the general conditions on the roadway. The sensor must detect at least the following conditions:
 - Dry roadway.
 - Wet/damp roadway.
 - Ice/frost on roadway.
 - Snow on roadway.
- The sensor must provide a coefficient of friction value for the monitored roadway.
- The sensor must provide a reading of the roadway conditions at least once per 5 minute interval.
- The sensor must provide a real-time output that is capable of sending data to a remote location via a collocated cellular data system. A simple ASCII or Hex output frame is expected. Documentation must be available to decode all data the sensor measures and sends including definition of units used and data ranges per data element.
- The sensor must provide one of the following physical communication interfaces:
 - RS-232.
 - RS-422.
 - RS 485.
 - Ethernet.
- The sensor must provide a software user interface to allow for remote monitoring, configuration, and diagnostics.

- The sensor must operate and provide expected quality of readings when mounted on roadside equipment such as overhead sign bridges, CCTV camera poles, and dynamic message sign structures. The sensor must be able to operate from at least 20 ft from the roadway.
- The sensor must fully operate with expected accuracy in all normal outdoor environmental conditions (i.e., hot, cold, heavy rain, fog, dust, smoke).

CHAPTER 4. SYSTEM ARCHITECTURE TO SUPPORT WEATHER RESPONSIVE TRAFFIC SIGNAL OPERATIONS

This chapter provides of the summary of the system architecture used to install weather-responsive traffic management (WRTM) systems at three coordinated arterials. The selected arterials are located in Dumas, Burluson, and Nassau Bay. Researchers also considered one single-intersection site in the Pharr District, but determined that a weather-responsive system was not justified there. Researchers decided that the weather-responsive system at each site will consist of:

- A set of sensors for detecting adverse weather conditions. For each site, all weather sensors will be installed at a selected intersection. This selection is based on the following factors:
 - Intersection geometry.
 - Existing infrastructure that can be used for sensor installation.
 - Availability of conduit space for providing power and communications capability to/from each weather sensor.
 - Availability of space in the cabinet for associated hardware.
 - Availability of video cameras at the intersection to allow visual verification of weather event, preferably from the traffic management center (TMC) or central locations.
- A small industrial computer will be installed in the same cabinet/intersection selected for installing weather sensors. Traffic signal cabinet must have adequate additional space for the computer. The computer will run custom software developed by the team. This software will perform the following functions:
 - Monitor real-time data obtained from weather sensors installed at the site.
 - Identify that a severe weather event has occurred and request the field hardware to implement an alternate timing plan suitable for handling the detected event.
 - Identify that a previously detected sever weather event has cleared and request the field hardware to resume normal operation.

DESCRIPTION OF SITES

The objective of system testing was to ensure that various components of the weather-responsive system installed at each site work as designed. At each site all required weather sensors were installed at a single location that best suited the project needs. However, because of site-specific differences, the testing plan described below was customized for each site.

US 287 in Dumas, TX

As shown in Figure 13, this site has seven intersections located along US 87. The following list summarizes characteristics of this site:

- Master controller is located at the intersection of 1st Street, which runs as isolated.
- The group of five signals from 4th to 8th St. runs as a coordinated system using a single time-of-day (TOD) plan at all times.
- Signal control is provided using old Eagle controllers installed in TS-1 cabinets.
- 14th St. Intersection runs in isolated mode.
 - Vehicle detection is provided using video cameras.
 - Communication to the master is via wireless connection.
- The site experiences significant north-south truck traffic.
- Snow/ice is the primary adverse-weather condition experienced at this location.

Weather-responsive system at this site includes the following components, all of which are installed at the 14th street intersection:

- One pavement sensor.
- One weather station (Davis).
- One industrial computer.

The weather-responsive system at this site includes:

- A new normal timing plan with 1st Street intersection included in the set of coordinated system.
- One new weather-responsive coordination plan developed by the research team for the coordinated system.
- One new weather-responsive plan developed for the isolated intersection located at the 14th street. Researchers investigated the possibility of installing a Wavetronix Extended-Range-Advance sensor to provide dilemma-zone protection to southbound trucks at the 14th street intersection, but did not install one due to lack of funds.
- An industrial PC identifies the presence or absence of adverse weather and triggers a call to a system detector to the 14th Street local controller via cabinet back panel. Through wireless communication, this system call passes to the master controller (located at the 1st Street), which responds by activating alternate timings in all local controllers. Lack of a system call deactivates master override and local controllers revert back to the normal timing plan for the coordinated system.

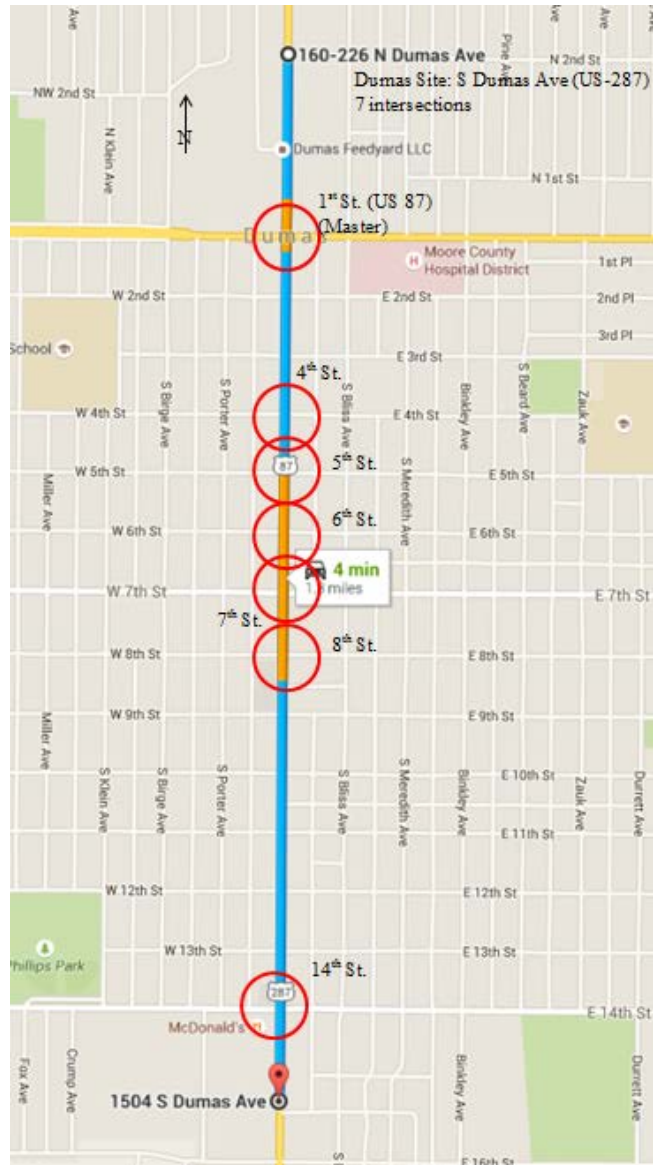

Figure 13. Map of Dumas Test Site.

SH 174 in Burleson, TX

This system consists of 10 intersections (Figure 14) located along SH 174. The system uses:

- Eagle/Siemens M50 controllers in TS-2 cabinets.
- Master controller is located at Summercrest Blvd/Garden Blvd. As opposed to the Dumas system, this location has a single box containing the master and a local controller.
- Four coordinated TOD timing plans plus free operation.
- Radar sensors for vehicle detection at most intersections and video detection at some intersections.

- Wavetronix Advance radar sensors to provide dilemma zone protection at some intersections during free operation.
- Two intersections in the system have video cameras with communications to the TMC. These cameras can be used to remotely verify the presence of adverse weather conditions and include:
 - Pan-tilt-zoom camera at one location.
 - Video cameras left when intersection detection was upgraded from video-based to radar-based.

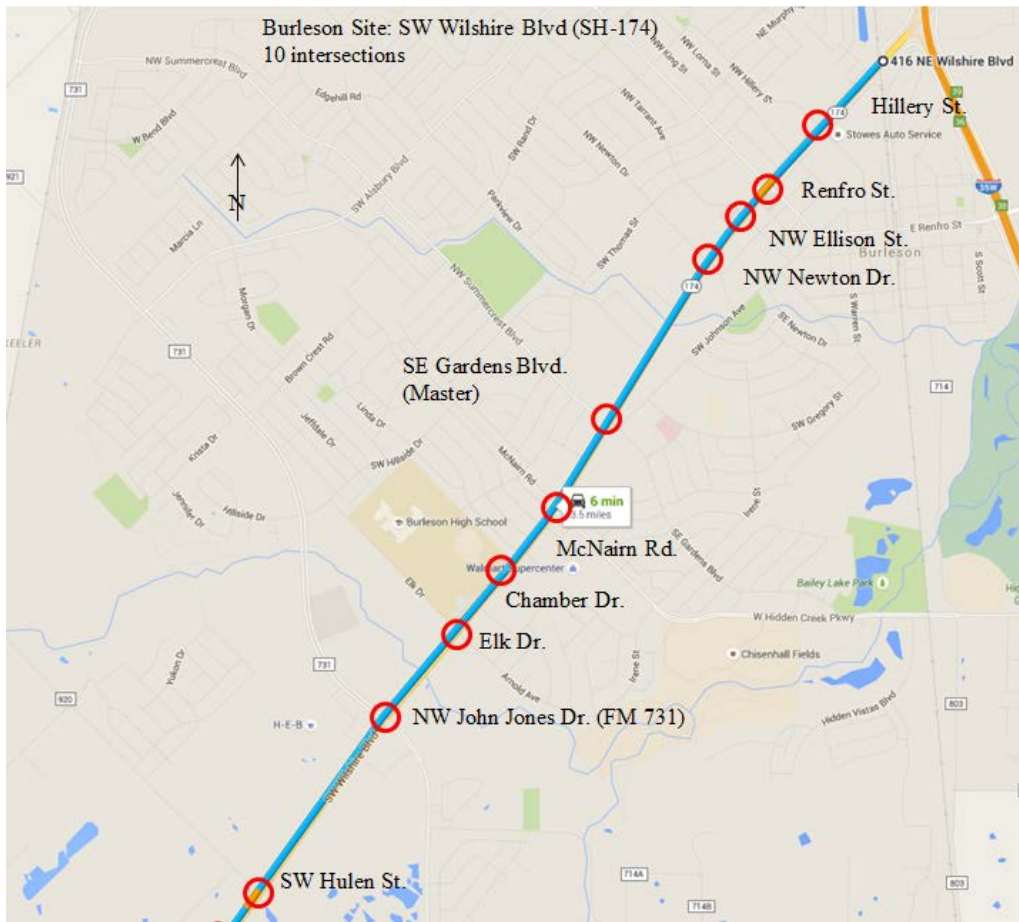

Figure 14. Map of Burleson System.

As shown in Figure 14, the system has a cluster of four closely-space signals (Hilary St. to NW Newton Dr.) on the northeast side, and an adjacent cluster of five closely-spaced signals (SE Garden Blvd to NW Jones Dr.). The last signal at Hulen St. is a T-intersection located at the southwest end of the system a significant distance (3,500 ft) away from the rest. At this intersection, cross-street traffic is extremely low and the intersection operates in a coordinated mode only during the AM- and PM-peak periods. TTI researchers have explored the possibility of improving traffic flow in the corridor by operating the two clusters of signals as separate

coordinated systems and leaving Hulen signal as isolated. Burleson WRTM system components are installed at Elk Drive, and include:

- A computer (processing unit).
- A pavement sensor.
- A weather station.

In addition, the system was programmed to have an alternate TOD weather-responsive plan corresponding to each normal TOD plan and free operations. The system at this site is designed to operate as follows:

- In real-time, the computer receives data from weather sensors and identifies if an adverse weather condition exists or (ceases to exist) and activates (deactivates) call to one of four detectors in the local controller by communicating to it through the signal cabinet. Each of these four detectors are configured as system detectors.
- The local controller passes system detector calls to the master controller, which uses traffic responsive features to issue a command to all local controllers to run an appropriate TOD action, which may be to:
 - Switching normal operation to an alternate weather-responsive timing plan for current time.
 - Switching from one alternate weather-responsive timing plan to another alternate weather responsive timing plan (i.e., from AM-peak to noon-peak).
 - Switching from an alternate weather responsive timing plan to an appropriate normal plan.

Researchers programmed the master to use Occ1, Occ2, Que1, and Que2 channels to activate one of four alternate timing plans.

Nasa Road 1

As illustrated in Figure 15, this system has six traffic signals, five of which are closely spaced. The signal system is operated using four TOD coordinated plans plus a free mode. The signals are connected to a central system, which does not exercise any control other than synchronizing controller clocks. Prior to system installation, the Houston District replaced all existing Econolite controllers with the latest Econolite Cobalt controllers capable of peer-to-peer communications, which the research team used to implement weather responsive actions.

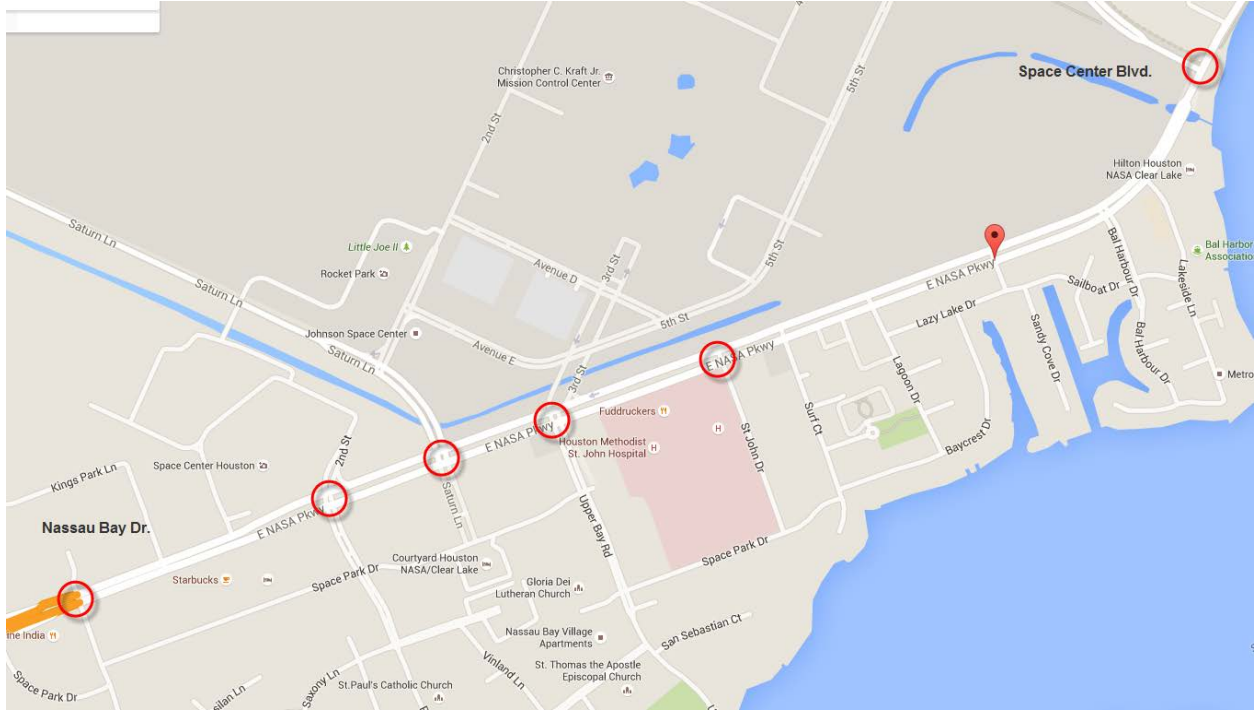

Figure 15. Map of NASA Road 1 System.

At this location, the weather-responsive system consists of the following components, all of which are located at Nassau Bay intersection (at the west end of the corridor):

- An industrial PC.
- A weather station.
- A visibility sensor.
- A pavement sensor.

In the proposed system, the following conditions apply:

- The system currently uses four coordinated TOD plans. For each coordinated TOD plan, researchers developed a corresponding alternate (weather-responsive) plan.
- The PC, located at Nassau Bay intersection, is programmed to use a local TOD schedule matching that of the system TOD schedule. When it detects a weather condition, it sends a signal to one of four preconfigured detector inputs to the controller via the signal cabinet. The inputs correspond to the TOD plan that is supposed to be active at that specific time and implicitly identifies the alternate weather-responsive TOD plan that needs to be activated.
- The local controller at Nassau Bay receives one of four inputs from the PC and activates the desired alternate timing plan via controller’s programmable logic capability, which researchers used to implement the desired actions.

- Researchers programmed similar programming logics in other local controllers. The only difference in these cases is that each of these local controllers uses peer-to-peer communication to monitor detectors activated by the PC at Nassau Bay controller to determine when an alternate plan is to be activated or deactivated.

SYSTEM COMPONENTS

Table 15 provides a summary of WRTM system components installed at each selected site. All equipment has already been ordered, some of which (i.e., weather sensors, and processing units) has also been received by the research team. The following section describes in more detail the sensors that are deployed at each of the test corridors.

Table 15. Components of WRTM System at the Selected Sites.

Location	Weather Station	Pavement Sensor	Visibility Sensor	Processing Unit
US 287, Dumas, TX	X	X		X
NASA Road 1, Nassau Bay TX	X	X	X	X
SH 174, Burleson, TX	X	X		X

Pavement Surface Sensor

The pavement surface monitoring sensor that was selected for deployment in this project was the IceSight Remote Surface Condition Sensor (Model 5433) produced by High Sierra Electronics. This sensor is a non-intrusive surface condition sensor. It uses laser and infrared eletro-optical technologies to assess surface condition, temperature, and reduction is surface grip due water, snow, and ice. The sensor can also report the following categories of road surface conditions:

- Dry.
- Damp.
- Wet.
- Standing water.
- Snow.
- Uncompacted snow.
- Ice.
- Black ice.

In addition to reporting the state of the road surface, the sensor also has the ability to provide a measure of the surface grip. Surface grip is a measure that indicates the relative grip of the roadway surface ranging from 1 (best) to 0 (worst). This grip factor is also used to classify surface conditions as good, fair, or poor. Figure 16 provides a photograph of the pavement surface condition sensor.



Figure 16. Pavement Surface Condition Monitor – Model 5433 “IceSight” by High Sierra Electronics.

The pavement sensor is installed at the intersection according to the vendor specifications. For this project, the pavement monitoring sensor is mounted on the mast arm of the traffic signal looking down in the outside lane of the main street departure approach. Figure 17 shows an example of a typical deployment.



Figure 17. Typical Installation of Pavement Surface Monitoring Sensor – Off Signal Mast Arm.

The research installed pavement surface condition sensors at all three sites (Nassau Bay, Burleson, and Dumas).

Visibility Sensor

A visibility sensor is installed at the NASA Road 1 (Nassau Bay) site. For this deployment, the research team selected the RWIS Road Visibility Sensor – Model 5434-00, also developed by High Sierra Electronic. The sensor is an optical sensor that measures the amount of scatter caused by particle in the air. The sensor has the capability of measuring visibility from 30 ft to over 10 miles. Figure 18 provides a picture of the visibility sensor used in this project.



Figure 18. High Sierra Visibility Sensor – Model 5434-00.

In this project, researchers chose to install the visibility sensor on the signal pole nearest to the traffic signal cabinet. Installation and maintenance is minimal for the Model 5434. A flange located on the bottom of the sensor signal processing box mates with a user supplied 1-1/2 inch IPS pipe. Power and signal connections are made through waterproof cable glands to terminal boards in the signal processing box.

Weather Station

In addition to the pavement and visibility sensors, the research team also installed Vantage Pro 2 weather stations produced by Davis Electronics at each of the deployment sites. The Vantage Pro 2 is a wireless weather station that contains a rain collector, temperature and humidity sensors, and anemometer (for measure wind speed and direction). The sensors themselves are solar powered and require not direct AV power source. Data collected by the station are transmitted wirelessly to a console installed in the cabinet. The console is used to display the collected weather data. The console is also connected to the PC so that weather condition data (temperature, humidity, precipitation rate, precipitation type, wind speed, and wind direction) can be logged for each location. These data are used to correlate weather conditions information

to the pavement surface condition and the visibility sensor. Figure 19 shows a picture of the weather station and the display console.



Figure 19. Vantage Pro 2 Weather Station and Monitoring Console produced by Davis Electronics.

The weather station was mounted to the traffic signal pole nearest the traffic signal cabinet.

Weather Processing Unit

The last piece of hardware installed at each location was a weather processing unit (WPU). The WPU is an industrial computer that is responsible for collecting the data from the various sensors, logging the weather data, and recommending plan changes to the traffic signal controllers. The WPU is also responsible for storing the evaluation data and issues weather alerts to the research team through a cellular data connection. Figure 20 shows an example of the WPU. The WPU is housed in the traffic signal controller cabinet. The dimensions on the WPU are 10 inches \times 6.0 inches \times 2.7 inches.



Figure 20. Weather Processing Unit.

GENERAL SYSTEM ARCHITECTURE

Figure 21 shows the general system architecture deployed at each of the test corridors. Whether pavement surface condition and visibility sensors are installed within a corridor depends on weather conditions experienced within the corridor. This intersection where weather sensors are installed does not necessarily have to be the intersection where the traffic signal master controller is located, but can be any intersection that has spare system or pedestrian detectors available. The WPU receives data about current conditions from site-specific weather sensors, determines if activation of a weather-responsive TOD timing plan is warranted, and activates preprogrammed alternate timing plans when appropriate. This scheme requires one weather-responsive TOD timing plan for each normal timing plan used in each controller at the selected site.

It also requires configuration of one unique detector input to trigger each alternate timing plan. Table 16 provides an example to illustrate this concept. The first and second columns in this table represent replication of the TOD schedule programmed in the on-site controllers, the second column shows alternate weather responsive timing plans, and the last column identifies spare detectors configured to activate alternate plans via controller and/or master programming options. In reality, WPU only uses a table with Columns 1 and 2. If WPU detects a weather event, it looks up the table to identify which detector to activate at the present time and then activates that detector. For instance, if a weather event is detected at 11:15, WPU will call Ped 1 detector to activate weather-responsive plan 5. If the weather event ends prior to 15:30, removal of Ped 1 will result in the system going back to Plan 1. However, if the weather event continues at 15:30 hours, WPU will continue remove call from Ped 1 and place a call on Ped 3, causing the controllers to switch from Alternate timing plan 5 to Alternate Timing Plan 6.

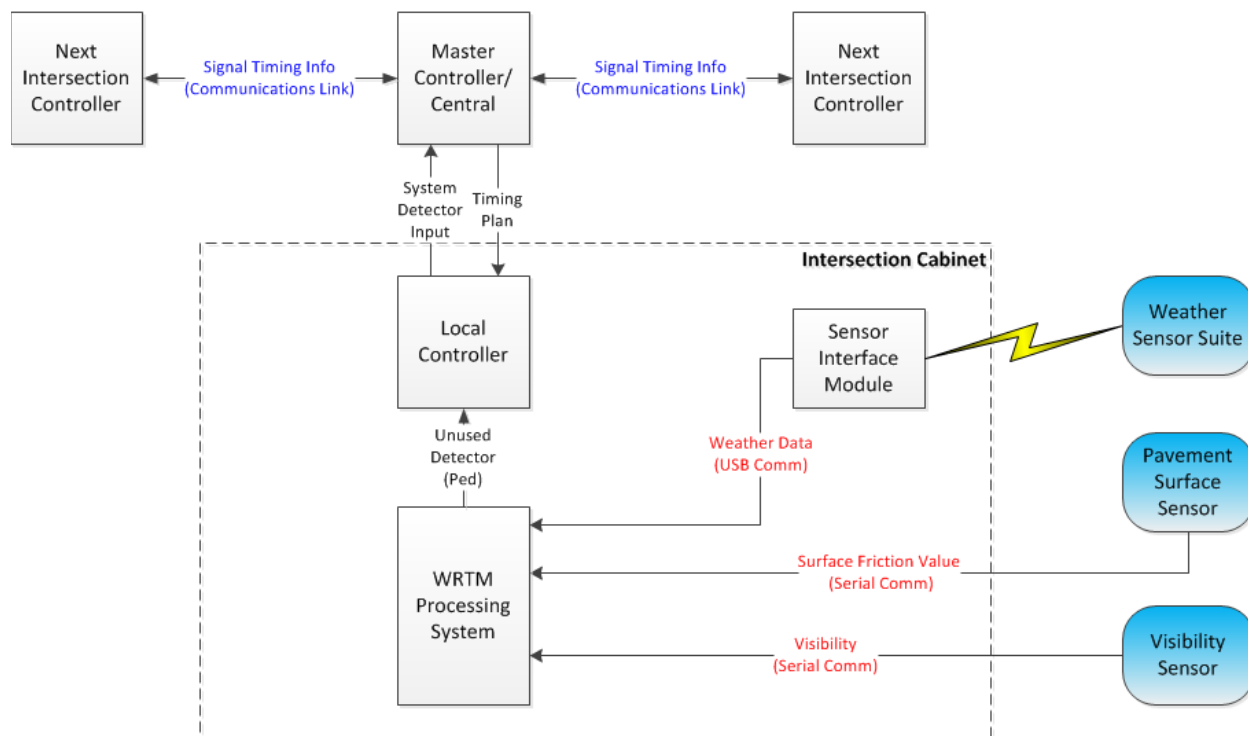

Figure 21. General System Architecture.

Table 16. Timing Plan Selection Scheme.

Time	Normal TOD Plan	Weather-Responsive Plan	Detector to Activate
7:00	1	5	Ped 1
15:30	2	6	Ped 3
20:00	3	7	Ped 5

In this scheme, some detectors (in this example Ped 1, Ped 2, and Ped 3) are configured as system detectors and information from them is used by the master controller to activate desired timing plans using preconfigured thresholds.

SYSTEM DEVELOPMENT AND IN-LAB TESTING

The following describes processes and procedures for deploying and testing the system components prior to installation at the selected field sites.

Weather Sensors

Upon the receipt of all three types of weather sensors, the research team assembled the units as necessary and conducted preliminary in-lab testing. The objectives of this testing were to:

1. Familiarize with the configuration and operations of each type of sensor, including input/output and interfacing requirements with TTI software.
2. To the extent possible, test/calibrate the sensors for different weather conditions. It was not possible to test all desired weather conditions, but some testing prior to field deployment is better than none.

Development of Site Specific Weather Responsive Actions/Architecture

As described in the previous section, the number and nature of weather-responsive actions for each selected site has certain unique aspects. Furthermore, differences in in-field hardware types and firmware capabilities (TS-1 vs. TS-2 cabinets, presence or absence of field master, etc.) between the selected sites also dictated the need to develop site-specific mechanisms for implementing proposed weather responsive systems. In other words, each site has slightly different implementation architecture, which needed to be tested in the lab prior to field deployment. Researchers created the following test beds to replicate and test weather-responsive system architecture at each site.

Dumas System

As illustrated in Figure 22, the test bed for Dumas consisted of the following components:

- One on-street master to represent the master located in the field at 1st Street.
- One local controller to replicate the operation at 1st Street.
- One local controller to replicate to replicate the operation at 4th Street.
- One local controller to replicate the operation at 14th Street.

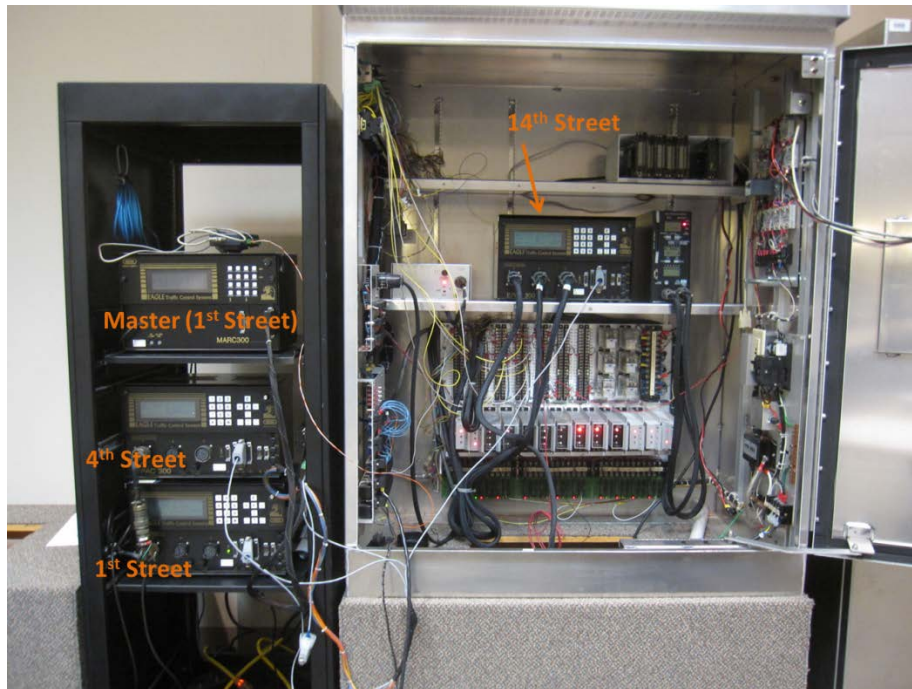

Figure 22. Mock of Dumas Deployment in TTI Laboratory.

Researchers used a special D-connector cable to provide communications between the master and local controllers.

The Dumas system was configured to run only one coordinated pattern. Therefore, researchers decided to create a single corresponding weather-responsive pattern and programmed it in the local controllers. Only one input is required to activate this alternate pattern when warranted. In the test bed, researchers decided to use Ped detector 1 for this purpose. However, any available detector can be in the field implementation.

In Figure 22, the controller in the cabinet emulates the controller at 14th Street. This is the location where researchers installed weather sensors. Consequently, the WPU is also supposed to be located here. At this location, controller runs free during normal conditions and will continue to run free during weather events. In the field, a PC located in this cabinet will activate the system detector. Because weather conditions could not be replicated in the lab, Ped detector 1 was connected to a digital card and enabled to allow an external process (manual or computer program) to generate a call emulating a weather event.

System master, located at 1st Street, receives system detector data from the local controller at the same location and activates desired weather-responsive plan. Because master is to be in control at all times, researchers replicated the local time-base schedule (same as in local controllers) in it and enabled it to take control at all times. Under normal (existing) conditions, 1st Street is not part of the coordinated system. Researchers decided to keep it the same during normal

conditions, but to make it a part of the coordinated system under weather-responsive timing plan. Researchers implemented this action by not programming a normal pattern in this controller. Furthermore, they programmed one of the two queue select routines to implement weather-responsive action.

Burleson System

Burleson system is similar to the Dumas system in that it also uses a field master controller. However, this system uses newer hardware, which consists of a single unit containing both the master and a local controller. As shown in Figure 23, lab testing of the Burleson system was accomplished using a single master/controller. The Burleson system uses four coordinated TOD timing plans plus free operation. Researchers developed an alternate weather-responsive plan for each normal plan. Four unique inputs are needed to activate the appropriate alternate timing plan. Because of their availability, researchers decided to use Ped detector inputs 1, 3, 5, and 7 for this purpose and mapped these detectors as system detectors in the local controller. Researchers also wired four outputs from a digital input/output device (seen on the bottom left corner in Figure 23) to these detectors via cabinet back panel. The master programming was similar to that described for the Dumas system, except that the researchers used four channels (Occ1, Occ2, Que1, and Que2) in the master to activate each one of the desired weather-responsive plan.

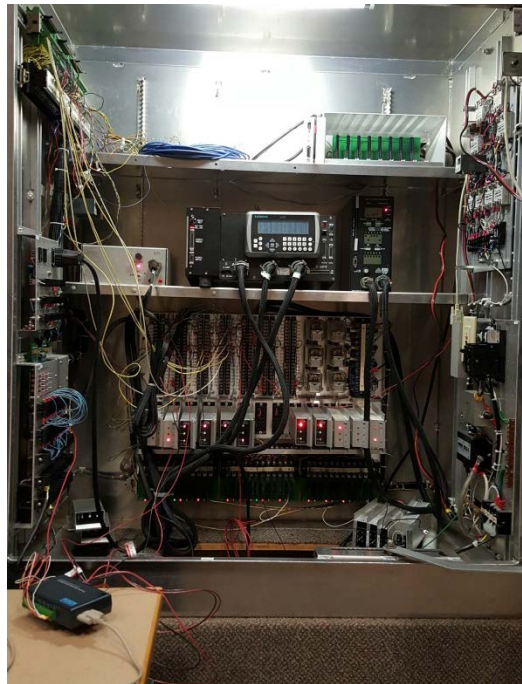

Figure 23. Mock of Burleson Deployment in TTI Laboratory.

Nassau Bay System

Nassau Bay system, located on NASA Road 1 Site is different from the other two systems in that it has no field master. Although there is center-to-field communications with the controllers, the system operates using four local TOD coordination plans. This system uses Econolite Cobalt controllers with peer-to-peer communication capabilities over an existing Ethernet network. These controllers also have built-in logic user-enabled programming capability. In the implementation architecture for this system, researchers decided to make use of these features.

Researchers created an in-lab replication of a subset of the signal system using three Econolite Cobalt controllers borrowed from the Houston District and connected them to an Ethernet router to create a local network. Researchers obtained in-field controller data from the district and downloaded it to the three controllers. Then, researchers programmed four additional alternate timing plans in each controller, established peer-to-peer communication between the controllers using the same IP addresses used in the field, and added logic programming code to activate and deactivate weather-responsive plans. Like the Burleson system, this system also uses four TOD plans. Therefore, researchers used four detector inputs to activate an appropriate plan as warranted by weather conditions and TOD schedule as explained earlier.

Figure 24 shows a picture of the test bed. In this figure, the controller on the left represents the controller in the field where weather sensors are installed. The test bed connected this controller to a TS-2 controller interface device, which was used by researchers to trigger weather events via a computer running TTI's hardware in the loop tool. This controller (referred to as Peer 1) was programmed to take action when any one of its four designated detectors received a call. The other two controllers represent two of the peers. They were programmed using the same logic. The only exception was that they monitored designated detectors for Peer 1 to make corresponding decisions.



Figure 24. Mock of Nasa Road 1 Deployment in TTI Laboratory.

Custom Computer Software

The TTI team developed custom software that will act as the brain of the WRTM system. It performed the following functions:

- Receive real-time data from the selected (configurable) subset of weather sensors available at the site and classify received data into categories, such as:
 - Rain: low, moderate, heavy.
 - Visibility: good, low.
 - Pavement condition: dry, wet, ice, snow.
 - Wind: calm/gentle, strong gale, storm, hurricane.
- Combine a weather-condition decision matrix together with TOD information to determine desired action (appropriate weather-responsive signal timing plan or parameters).
- User/activate appropriate mechanism for communicating desired actions to the selected controller(s). These mechanisms will include Ethernet-based communications with a controller or communications through the signal controller cabinet via a 24-volt digital I/O card. In the latter case, the input from the PC may activate an alarm through the back panel (TS-1 cabinet) or via Ped Inputs (TS-2 cabinet).

In-lab Testing of System Subcomponents and Site Specific Architecture

Using lab test beds described above, researchers tested the functionality of all subsystems for each selected site. As stated above, it was not possible to test weather sensors for this testing. Rather, researchers manually triggered designated sensors to emulate adverse weather conditions and TOD pattern selections. Specifically, this stage of testing verified the following for each site as appropriate:

- Communication of TOD triggers from the PC to the cabinet.
- Communication of triggers from the cabinet to the local controller.
- Communication of triggers from the local controller to the master.
- Communication of actions from the master to local controllers in the system and their response.
- Communication of triggers from the PC directly to one or more controllers, peer-to-peer-communications, and controller response in Ethernet based system.

Because of fast-approaching winter season and its potential impact on the selected sites, Dumas WRTM system was the first field deployment, followed by Burleson, and NASA Road 1. There was an overlap in the in-lab testing and field deployment activities.

CHAPTER 5. EVALUATION OF SIGNAL TIMING DEPLOYMENT STRATEGIES

This chapter highlights the deployment and evaluation of weather responsive signal operations at three locations in the Texas. Lessons learned and implementation guidance developed as a result of these field deployments are provided at the end of this technical memorandum.

FIELD DEPLOYMENTS

The TTI research team deployed and evaluated weather responsive traffic signal timing plans at three locations: US 287/US87 in Dumas, TX; SH 174 in Burseson, TX; and NASA Road 1 in Nassau Bay, TX. The following sections provide summaries of those deployments and the results of the evaluation studies conducted at those locations.

US 287/US 87 in Dumas, TX

The first site where the weather responsive traffic signal system was deployed in Dumas, TX, on US 287/US 87. Located north of Amarillo in the Texas Panhandle, Dumas is a relatively small rural city (population approximately 1500 people). The system was deployed on US 287/US 87, one of the major thoroughfare through Dumas. US 287/US 87 has a significant volume of commercial vehicles moving through the town. Figure 25 provides an overview of where Dumas is located while Figure 26 provides an overview of the intersections included in the weather responsive system.

In this part of Texas, ice is the predominant weather feature that impacts traffic operations. Dumas receives an average annual snowfall of approximately 13 inches. Because of the likelihood for snowfall in the region, the system was deployed to monitor pavement and ice conditions on US 287. Table 17 provides a summary of the climatology data for Dumas, TX.

Table 17. Climatology Data for Dumas, TX.

	Jan	Feb	Mar	Apr	May	Jun
Average High in °F	49	52	61	69	78	87
Average Low in °F	22	24	31	40	50	60
Average Precipitation in Inches	0.63	0.51	1.26	1.3	2.17	2.4
Average Snowfall in Inches	3	2	3	1	0	0
	Jul	Aug	Sept	Oct	Nov	Dec
Average High in °F	92	90	82	71	59	48
Average Low in °F	65	64	56	43	31	23
Average Precipitation in Inches	2.44	2.87	1.85	1.38	0.75	0.83
Average Snowfall in Inches	0	0	0	0	1	3

Source: U.S. Climate Data. Available at <http://www.usclimatedata.com/climate/dumas/texas/united-states/ustx0388>



Figure 25. Site Location – US 287/US 87 in Dumas, TX.

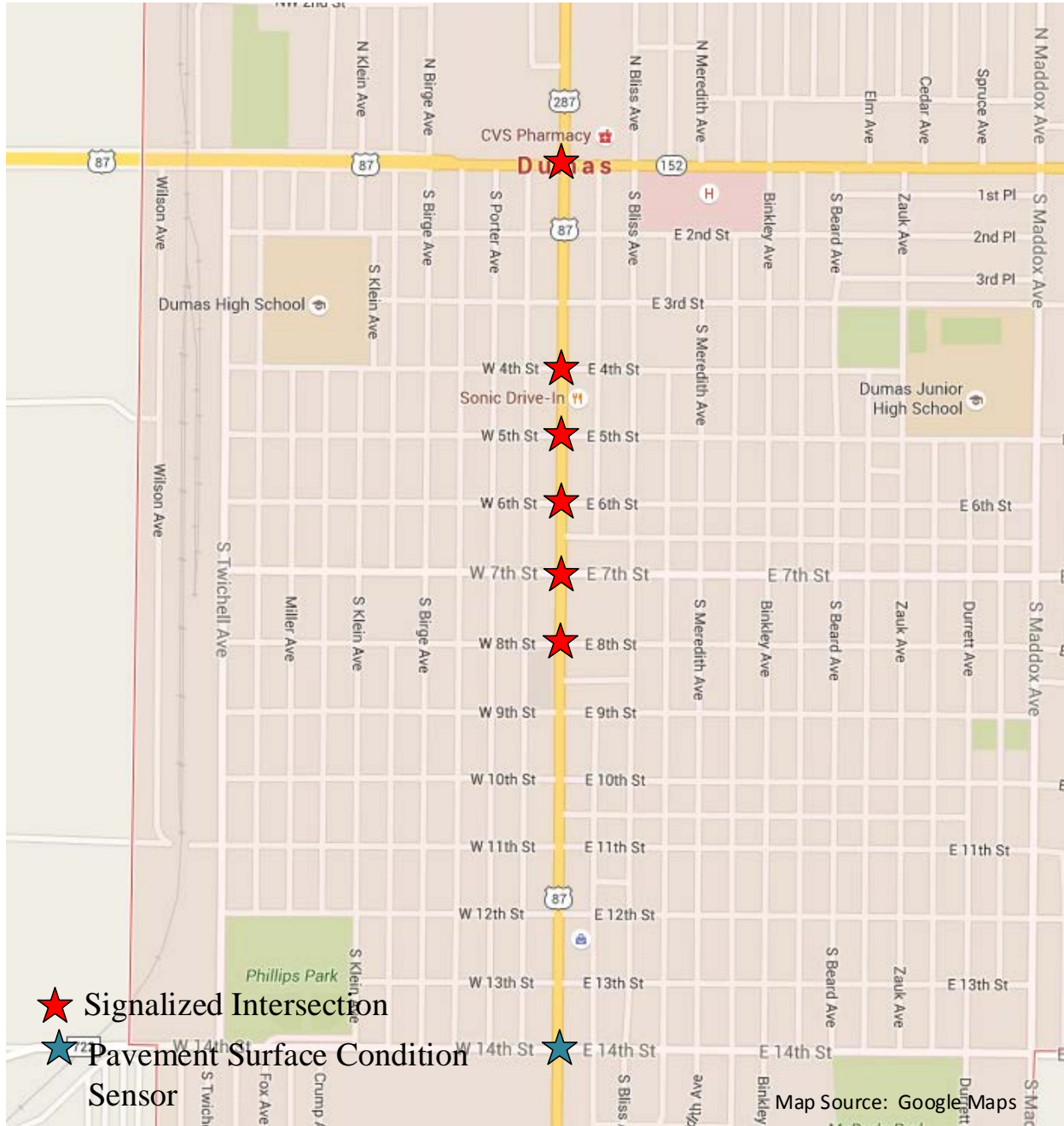

Figure 26. Location of Signalized Intersections – US 287/US 87, Dumas, TX.

Weather Responsive Signal Timing Strategies

At this site, the weather responsive system was deployed to handle wet weather and icing events. A pavement surface condition sensor was deployed at the W. 14th St. intersection and connected to the master traffic signal controller located at the W. US 87/W. 1st St. Figure 27 provides photographs of the deployed pavement surface condition sensor and the weather station at the W. US 87/W. 1st St. intersection.



Figure 27. Weather and Road Surface Condition Monitoring Systems Deployed in Dumas, TX.

The system was programmed to activate the weather responsive timing plans when the pavement sensors detected a pavement friction factor below 0.3 and to return to normal operations when the pavement conditions improved above 0.4. Appendix A provides the weather responsive timing plans deployed at the site.

Evaluation Results

Manual observations and data collection were performed at this site during a minor snow event that occurred in January 2016. Data collection consisted of manual collection of travel time information using a floating car technique. Two vehicles were used to collect the travel time data.

The data collection was divided into two periods: one without the weather responsive system active (referred to as the “without” period) and one with the weather responsive system active (referred to as the “with” period). During the without period, the weather responsive timing plans were not active even though snow was falling. Data were collected for approximately 1 hour in the without period, beginning at around 5:30 a.m. and continuing until approximately 6:30 a.m. During the “with” period, travel time data were collected with the system running the weather

responsive traffic signal timings. Snow continued to fall throughout the entire with data collection period. Travel time data were collected for a total of approximately 2½ hours with the system actively running the weather responsive timing plans, beginning around 8:30 a.m. and lasting until approximately 11:00 a.m. The rate of snowfall was relatively light and the entire weather event resulted in only a slight accumulation of snow (less than a ¼ inch in total accumulations).

Figure 28 compares the average travel time of the floating cars in both directions of travel, with and without the weather responsive timing plans active. The figure shows that travel times increased by approximately 20 seconds in both directions of travel with the weather responsive timing plans active than without. This was expected because one objective of using weather responsive timings is to force vehicles to travel at lower speeds; however, other factors may have also contributed to the increase in travel times. The without travel time data were collected very early in the morning (before 6:30 a.m.) and traffic conditions were considerably light during this time period. Also, weather conditions were slightly worse during the with time period than the without period with more accumulation of snow occurring during the with period.

The research team was unable to study the safety aspects of implementing weather responsive timings in this project due to the limited duration of this study. Future projects should examine the impacts of using weather responsive traffic signal operations on safety.

Because of the manner in which the data were collected (manually versus automatically), the research team was also unable to evaluate the effects of the weather responsive signal timings on delays and queues in the network.

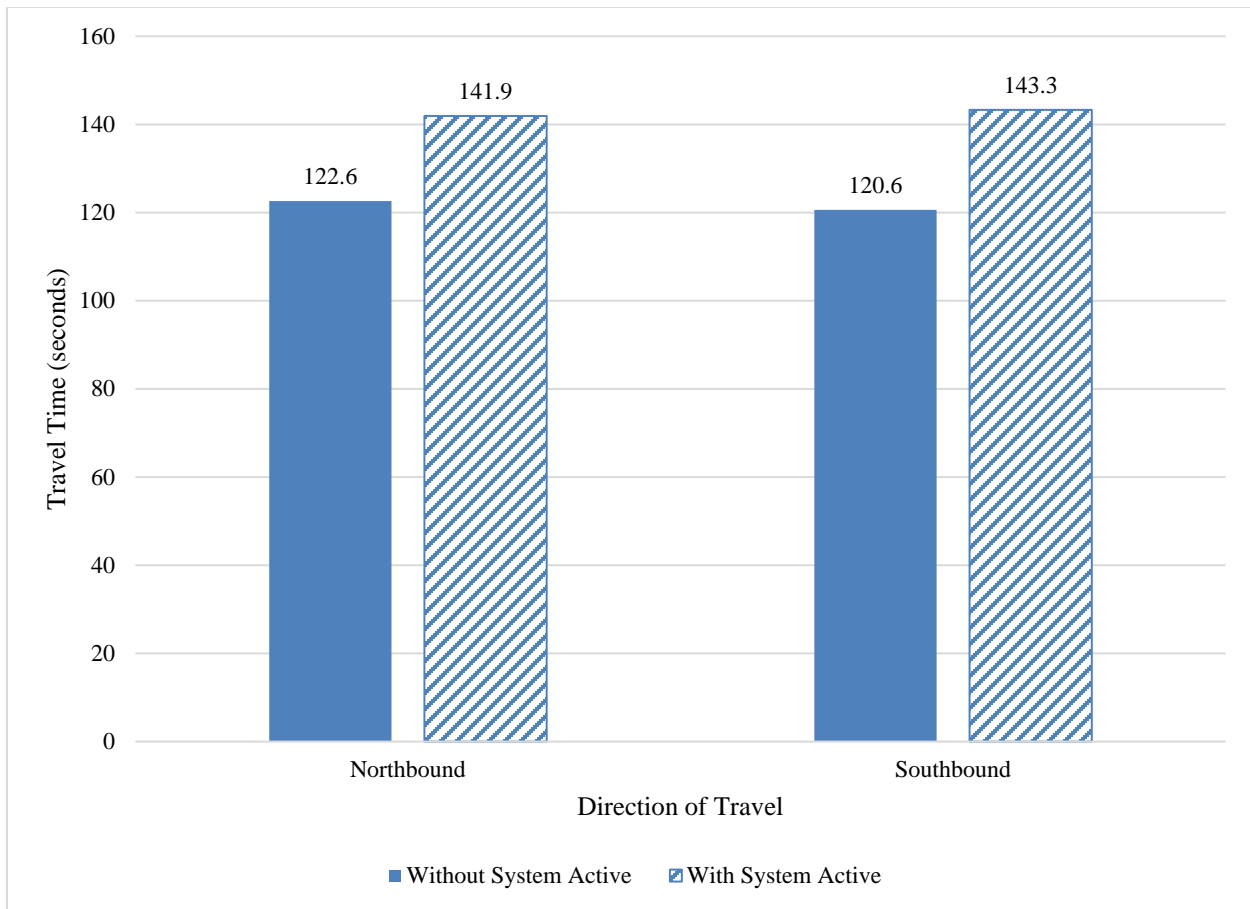

Figure 28. Corridor Travel Times on US 287/US 87 in Dumas, TX, with and without Weather Responsive Signal Timings.

SH 174, Burleson, TX

The second site was located on SH 174 in Burleson, TX. Burleson is a small community located south of Fort Worth. The test corridor includes a total of 11 signalized intersections and is approximately 15 miles in length. Figure 29 provides an overview of the location of Burleson, relative to Fort Worth. Figure 30 shows the locations of the signalized intersections located in the corridor. **Error! Reference source not found.** Table 18 provides the climatology data for Burleson, TX.

Weather Responsive Signal Timing Strategies

At this site, weather responsive traffic signal timing plans were developed for wet weather and icing events. A pavement monitoring sensor was deployed at the Elk Dr. intersection. Figure 31 show the weather equipment deployed at the intersection. The system was programmed to activate the weather responsive timing plans when the pavement sensors detected a pavement friction factor below 0.4. Appendix B shows the weather responsive timing plans deployed at the site.

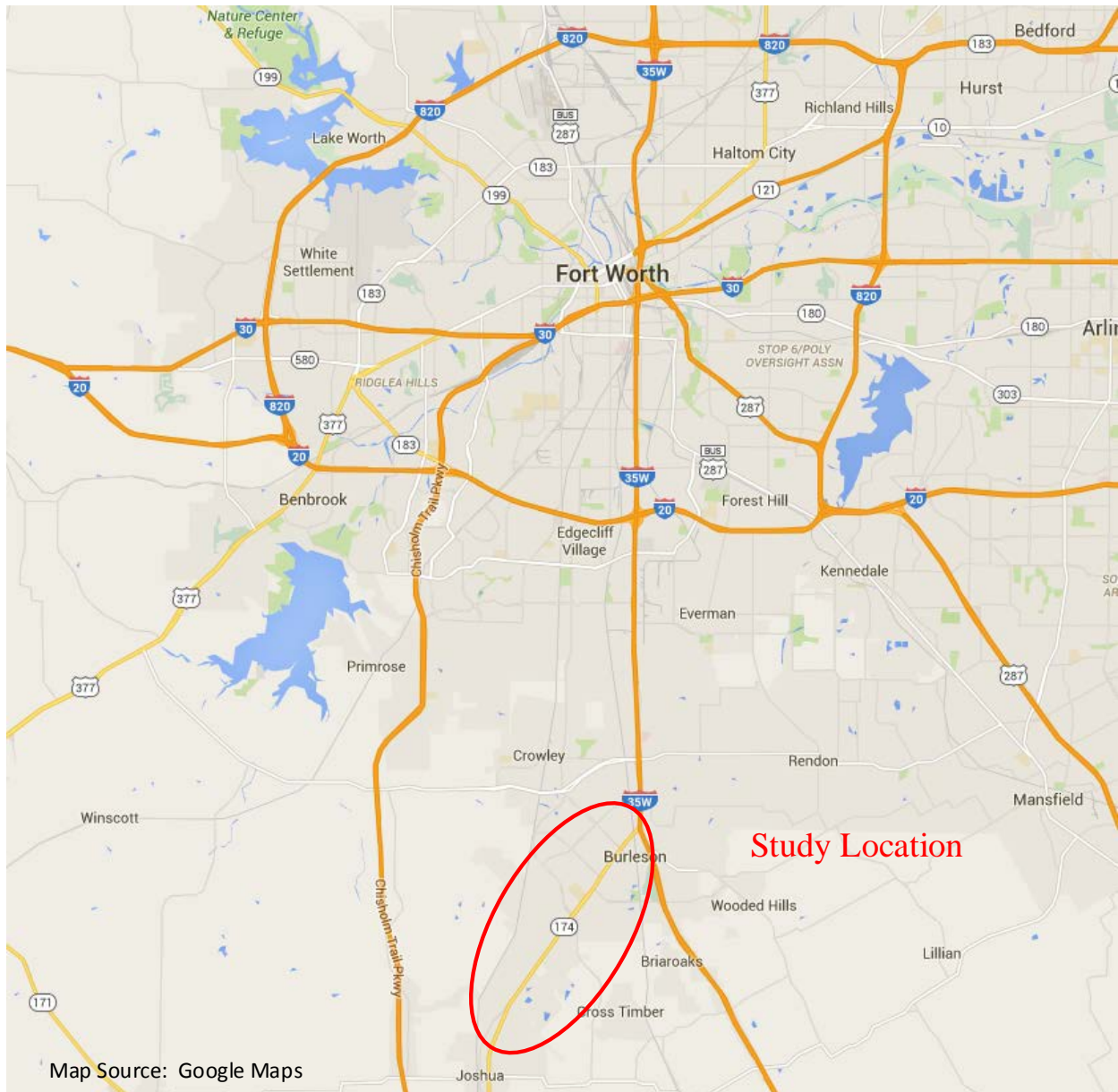

Map Source: Google Maps

Figure 29. Site Location – Burleson, TX.



Pavement Surface Condition Monitoring System



Weather Monitoring Station

Figure 31. Road Surface Condition Monitoring and Weather Monitoring Station Deployed on SH 174 in Burleson, TX.

Table 18. Climatology Data for Burleson, TX.

	Jan	Feb	Mar	Apr	May	Jun
Average High in °F	56	59	67	76	82	89
Average Low in °F	33	37	44	52	61	69
Average Precipitation in Inches	2.09	2.64	3.62	2.8	4.53	4.02
Average Snowfall in Inches	-	-	-	-	-	-
	Jul	Aug	Sept	Oct	Nov	Dec
Average High in °F	94	95	87	77	66	56
Average Low in °F	72	72	68	54	44	35
Average Precipitation in Inches	2.4	2.28	3.23	4.29	2.6	2.52
Average Snowfall in Inches	-	-	-	-	-	-

Source: U.S. Climate Data. Available at <http://www.usclimatedata.com/climate/burleson/texas/united-states/ustx0184>

Evaluation Results

TTI performed a simulation analysis of the proposed weather responsive timing plans. The simulation study examined the impacts of implementing the proposed weather responsive timing

plans assuming different levels of speed reduction due to weather impacts. The research used the following four performance measures to evaluate the effectiveness of the weather responsive timing plans:

- Average corridor travel time.
- Average approach delay.
- Average stop delay.
- Average number of stops.

Average Corridor Travel Time. Average corridor travel time is the average time required by vehicles to travel from one end of the corridor to the other. It is intended to be a measure of the quality of flow for those vehicles that are traveling through the corridor. The research team examined average corridor travel time in both directions of travel on SH 174.

Figure 32 shows the effects of implementing the weather responsive timing plans during significant weather events during the AM and PM peak periods on SH 174 in Burleson. The analysis shows that for both the AM and PM peaks, the weather responsive timing plan resulted in slight improvements in average travel times in westbound direction during these peak periods. The analysis also showed that average corridor travel time increased by 33 seconds in the eastbound direction and decreased by approximately 30 seconds in the westbound direction during the PM peak. This analysis assumes that the weather event is significant enough to cause travel speeds in the corridor to drop from 55 mph to 30 mph, a 25 mph reduction in speed. This suggests that the PM peak weather responsive timing plans should be adjusted to achieve a better balance in corridor travel time during significant weather events.

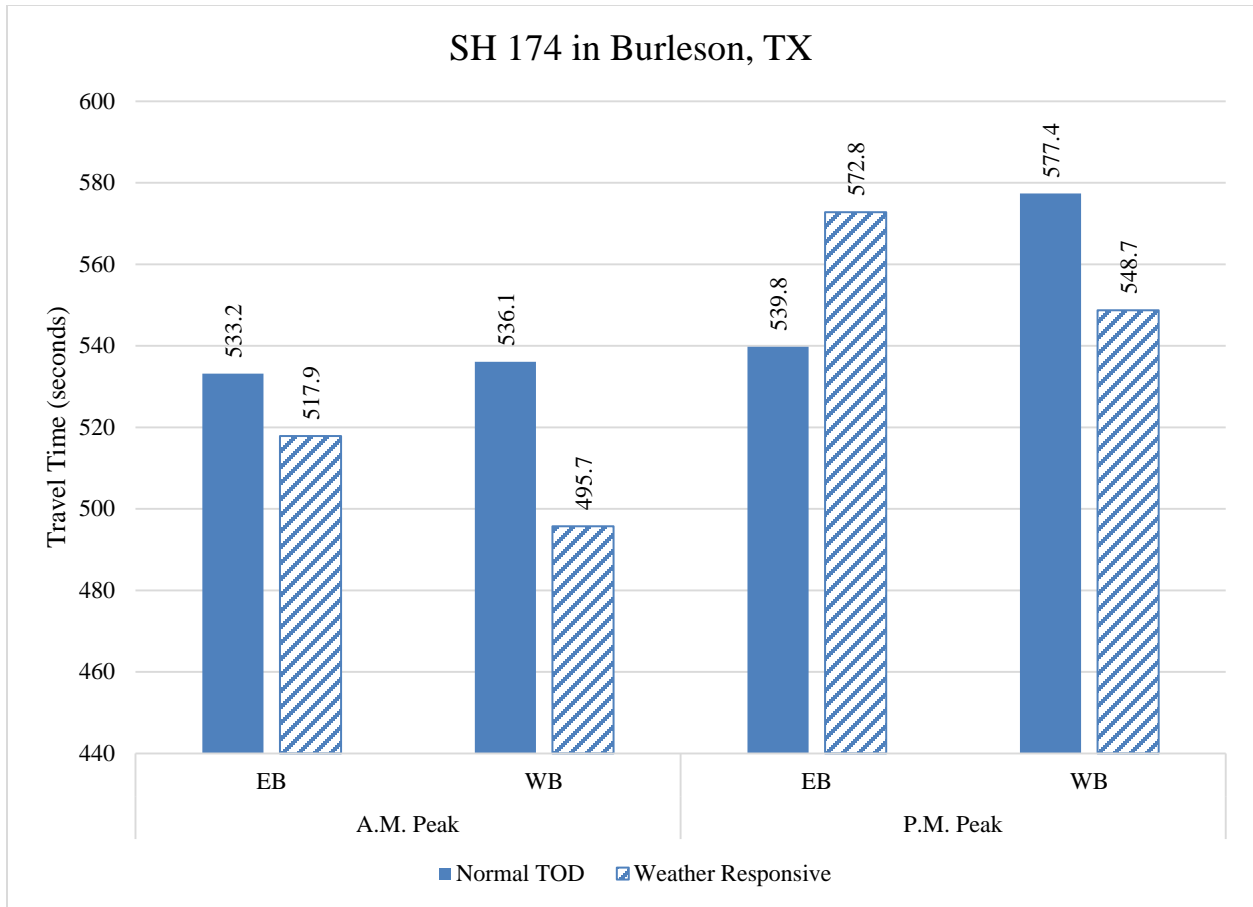

Figure 32. Average Travel Time – SH 174, Burleson, TX.

Average Approach Delay. Figure 33 shows the impact of implementing the weather responsive timing plans on the average approach delay compared to using the normal TOD timing plans during a significant weather event. The figure shows that the weather responsive timing plans produced a 20 and 37 second reduction in average approach delay in eastbound and westbound directions of travel compared to the normal TOD signal timing plans during the AM peak. For the PM peak, the weather responsive timing plans produced mixed results, causing the average approach delay to increase by approximately 35 seconds in the eastbound direction while at the same time producing a 26 second reduction in average approach delay in the westbound direction.

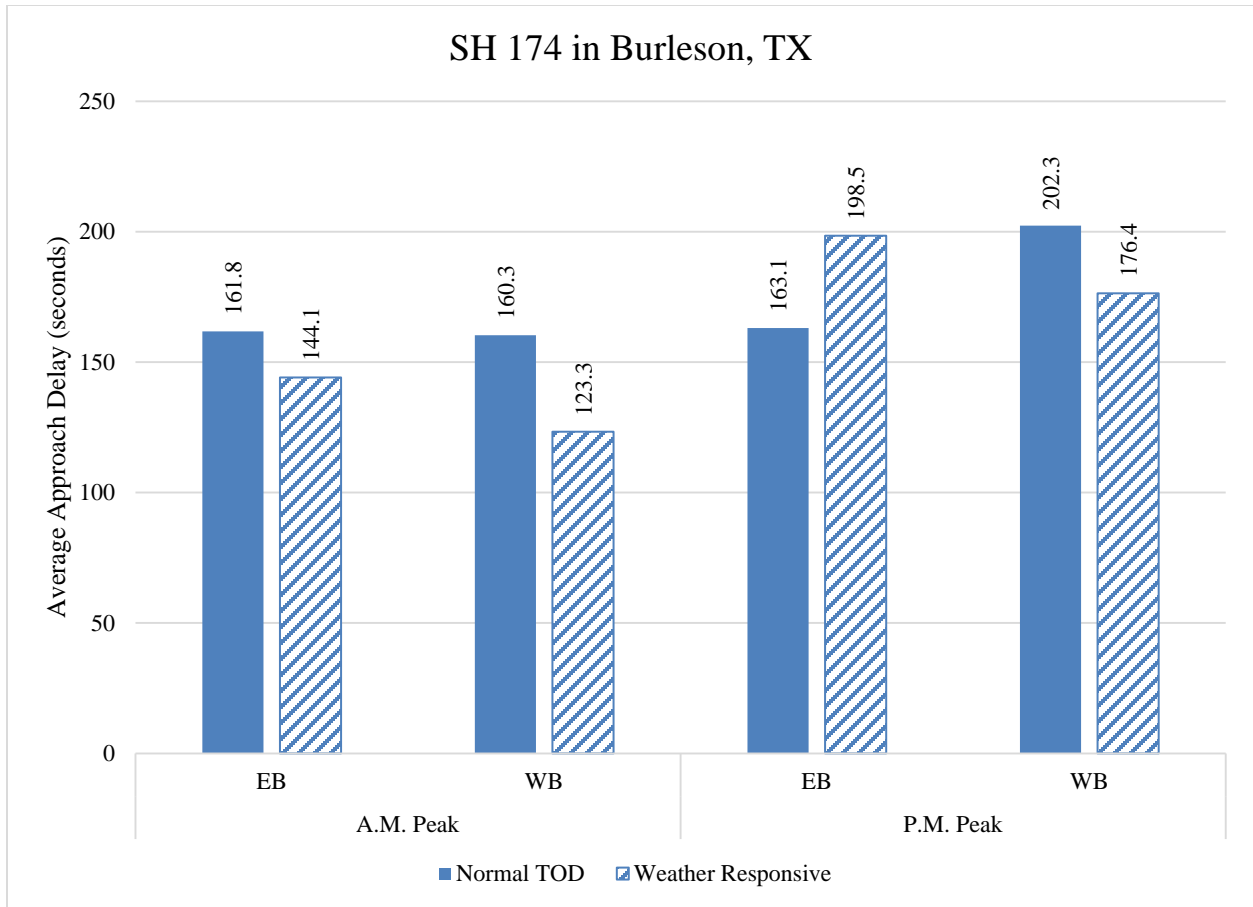

Figure 33. Average Approach Delay – SH 174, Burleson, TX.

Average Stop Delay. Average stop delay is the average amount of time that vehicles are stopped on the approaches to signalized intersections throughout the corridor. A vehicle is defined as being stopped when its travel speed is less than 3 mph. For this analysis, the researchers examined stop delay for eastbound and westbound approaches only, the primary directions of travel in SH 174.

Figure 34 shows the impacts of implementing the weather responsive timing plans on the average stop delay. The figure shows that the weather responsive traffic signal timing plans reduced average stop delay in both directions in the AM peak. During the AM peak, the weather responsive timing plans produced a 14 and 43 second reduction in stop delay for the eastbound and westbound directions, respectively. In the PM peak period, average stop delay increased slightly (approximately 19 seconds) for traffic traveling in the eastbound direction, but decreased by 16 seconds in the westbound direction. Again, fine-tuning the weather responsive timing plans may help balance the changes in stop delay during the PM peak.

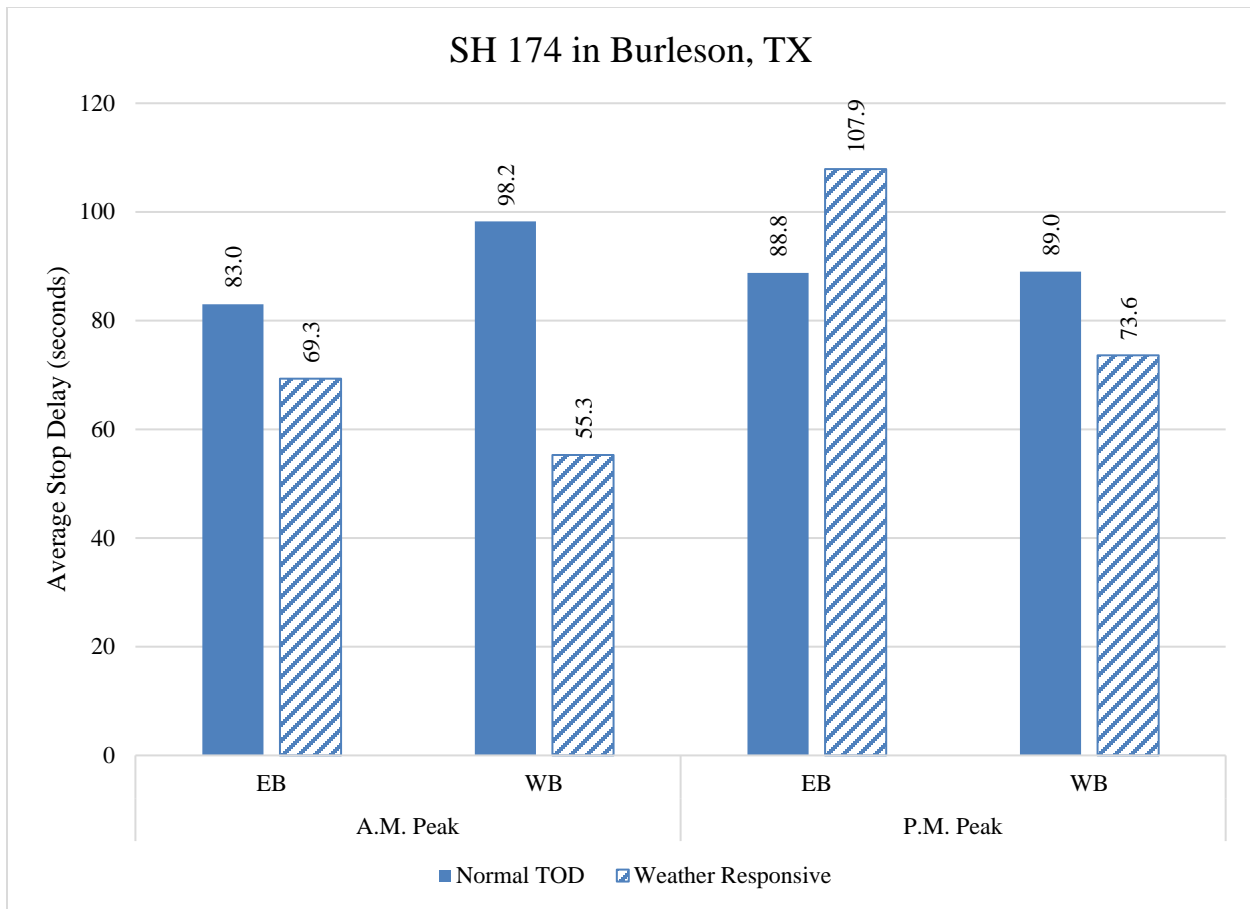

Figure 34. Average Stop Delay – SH 174, Burleson, TX.

Average Number of Stops. Figure 35 shows the impact of weather responsive timing plans on the average number of stops a vehicle had to make during a trip through the corridor. The figure compares the average number of stops produced by the weather responsive timing plans against the average number of stops produced if the normal TOD timing plans were used during a significant weather event.

The analysis shows that the average number of stops decreased slightly in both directions of travel during the AM peak compared to the normal TOD timing plan. For the AM peak, the average number of stops per vehicle decreased from 3.2 to 2.7 in the eastbound direction and from 3.2 to 2.9 in the westbound direction when the weather responsive timing plan was used. For the PM peak, the average number of stops decreased from 3.3 stops per vehicle to 2.1 stops per vehicle in the westbound direction when the weather responsive timing plan was deployed; however, in the eastbound direction, the average number of stops increased from 2.7 stops per vehicle to 3.8 stops per vehicle when the weather responsive timing plan was deployed. Again, this suggests that fine-tuning is needed for the weather responsive timing plan for the PM peak to achieve a better balance between the two directions for flow.

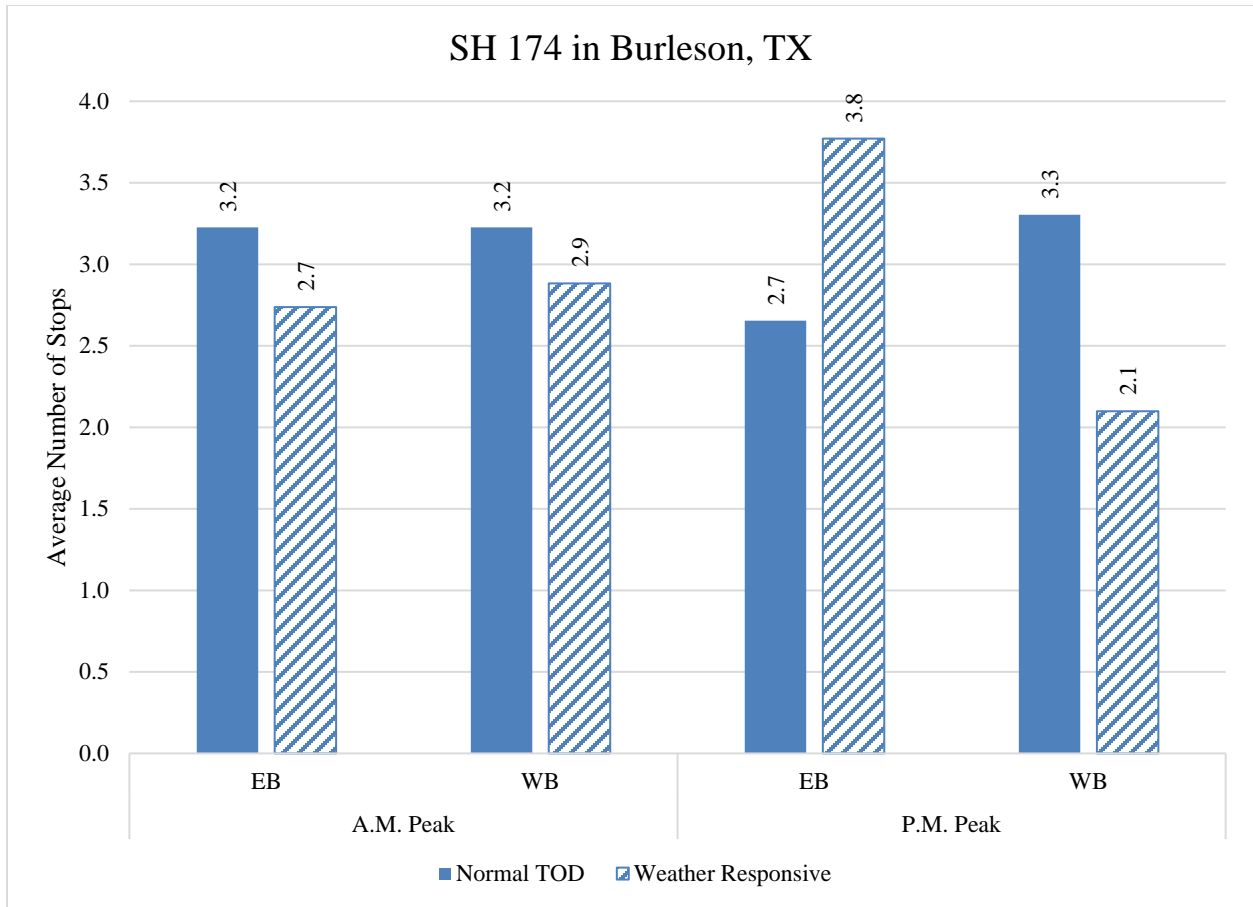

Figure 35. Average Number of Stops – SH 174, Burleson, TX

NASA Road 1, Nassau Bay, TX

The final site where the weather responsive traffic signal system was deployed was on NASA Road 1 in Nassau Bay, TX. NASA Road 1 is a major commuting corridor in Nassau Bay, serving the Johnson Space Center and other major commercial establishments. In addition to commuter traffic, the corridor is heavily used by tourist traffic heading to the Johnson Space Center, Nassau Bay, and the Kemah Board Walk. Figure 36 provides an overview of the location of the deployment site while Figure 37 shows the locations of the signalized intersection included in the system.

The system that was deployed in this corridor was primarily for rain events that impact pavement surface conditions and visibility events caused by fog situations. Table 19 provides the climatology data for Dickinson, TX, which is located near Nassau Bay.

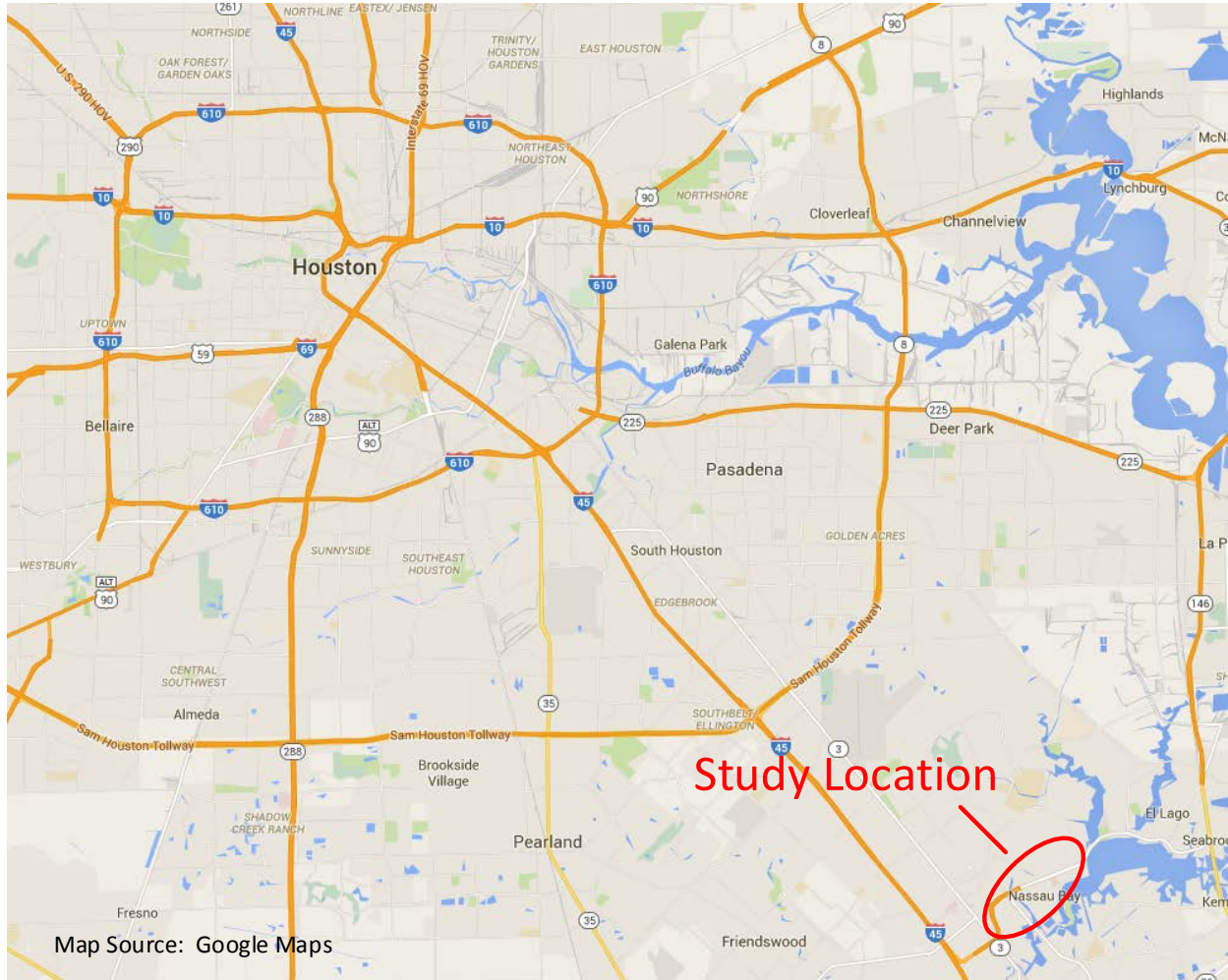

Figure 36. Site Location – NASA Road 1, Nassau Bay, TX.

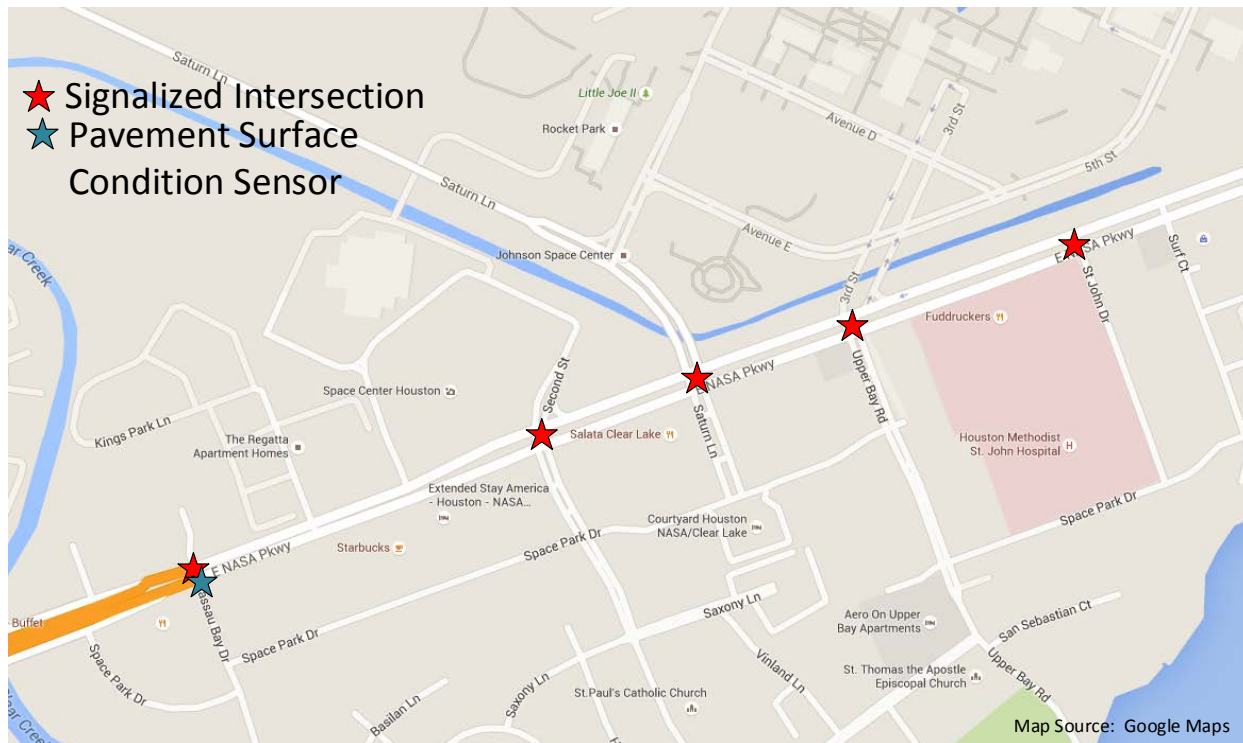

Figure 37. Location of Signalized Intersections – NASA Road 1, Nassau Bay, TX.

Table 19. Climatology Data for Dickinson, TX – Located near NASA Road 1.

	Jan	Feb	Mar	Apr	May	Jun
Average High in °F	62	65	71	77	83	88
Average Low in °F	43	47	53	59	67	72
Average Precipitation in Inches	4.49	2.91	3.23	3.31	4.65	6.42
Average Snowfall in Inches	-	-	-	-	-	-
	Jul	Aug	Sept	Oct	Nov	Dec
Average High in °F	91	91	87	80	72	64
Average Low in °F	73	73	69	60	52	45
Average Precipitation in Inches	4.57	5.16	7.17	5.94	4.92	4.06
Average Snowfall in Inches	-	-	-	-	-	-

Source: U.S. Climate Data. Available at <http://www.usclimatedata.com/climate/dickinson/texas/united-states/ustx2181>

Weather Responsive Signal Timing Strategies

At this site, two types of weather sensors have been integrated into the system: a pavement monitoring sensor and the visibility sensor. The system has been programmed to activate weather responsive timing plans when visibility becomes poor (less than 700 foot) or if friction factor, as measured by the pavement sensor, drops below 0.4. The weather responsive timing plans that are implemented are contained in Appendix C.

Evaluation Results

TTI performed a simulation study for NASA Road 1 in Nassau Bay, TX, similar to the one for SH 174 in Burlison, TX. The corridor was simulated in VISSIM 7 with the normal TOD (existing) timings and the proposed weather responsive timings. Performance measures were evaluated for varying speeds of traffic for each model.

The NASA Road 1 study had a few differences to the SH 174 simulation study. Since the maximum speed of the NASA Road 1 study was lower than SH 174, the simulation speeds varied from 5 mph above the posted speed limit to 5 mph below the design speed for the weather responsive timing plans. This alteration was to expose the behavior of the timing plans when the traffic is going faster and slower than design. This report focuses on the results of 30 mph case, which is meant to represent a significant weather event.

Another difference between the NASA Road 1 and SH 174 simulation studies is that the timing plans that were considered normal TOD were altered. The research team identified signal timing problems at the Space Center Blvd and Saturn Lane intersections with the existing timings. The signal timings for Space Center Blvd could not service the northbound left-turning traffic in either the AM or PM peak timings. Green time was taken for the southbound through movement, which did not have any queueing issues, to service the left turning traffic. Space Center also could not clear the queues for the eastbound approach during the PM peak, so green time was taken from the westbound through approach on NASA 1 to address the excessive queueing. The intersection at Saturn Lane posed significant queueing issues for the southbound traffic in the PM peak period. This queueing problem was handled by taking green time from the northbound phase. These changes addressed the queueing issues identified by the research team so that the timing plans could be evaluated on their best ability to handle traffic. The weather responsive timing had the same treatments for excessive queueing.

For the sake of modeling the traffic accurately, the southbound link of Saturn Lane needed to be extended beyond its real world dimensions for the PM peak model. This was done in order to give the simulated vehicles enough space to change lanes for their desired turning movements. The traffic going southbound on Saturn Lane was assumed to know which lane they need to be in better in the real world than in the simulation, so the simulation needed more space in order to complete the lane changes than the vehicles would in the real world. The AM peak model for Saturn Lane remained the same as the true dimensions of the roadway.

The same performance measures were used to evaluate timing plan effectiveness. The maximum queue length and number of queue stops were used to evaluate the effectiveness of eastbound and westbound traffic on the inner intersections along NASA Road 1.

Average Corridor Travel Time. The impacts of the weather responsive timing plans are compared to the normal TOD timing plans during a significant weather event in Figure 38. The

two timing plans showed about the same performance. The weather responsive timing was consistently lower than the normal TOD. The maximum improvement was observed for the westbound traffic in the PM peak, where the normal TOD travel time was 391.7 seconds and the weather responsive travel time was 366.8, saving a total of 24.9 seconds. Some additional calibration of the weather responsive timings may result in a better travel time improvement.

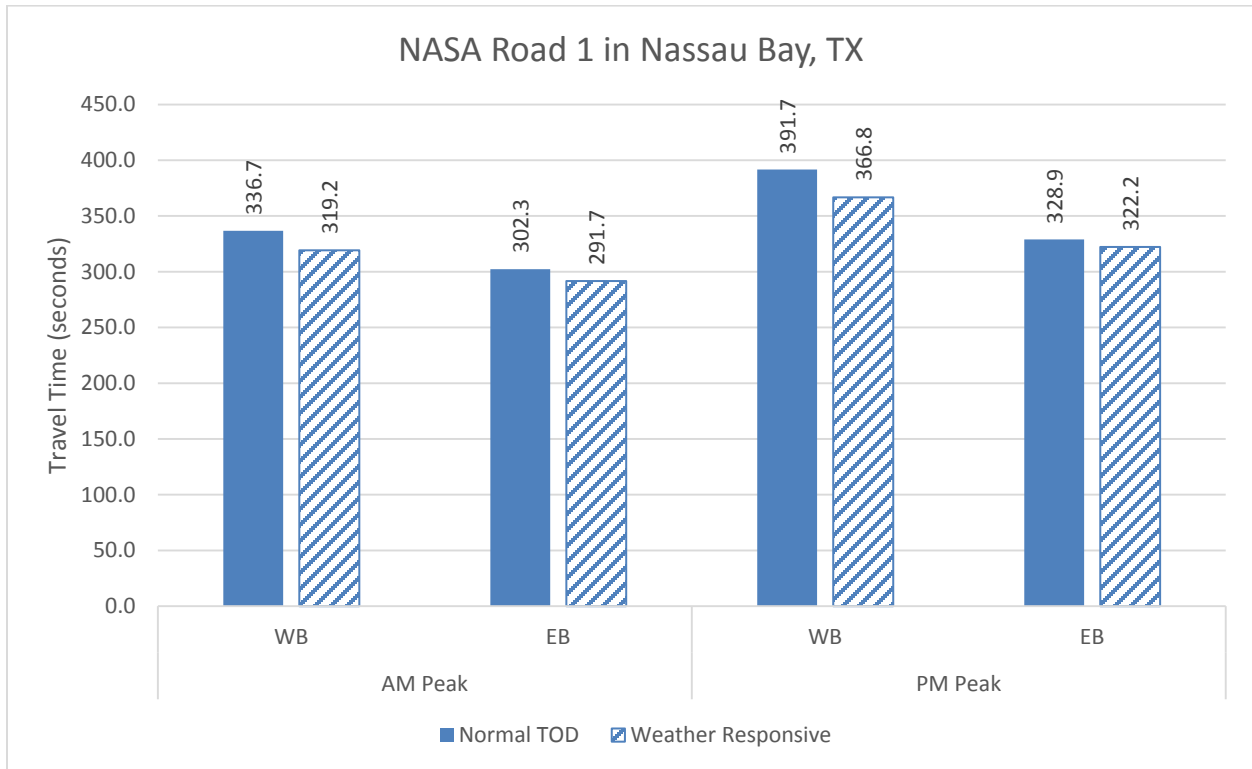

Figure 38. Average Travel Time – NASA Road 1 in Nassau Bay, TX.

Average Approach Delay. The average approach delay measures the average amount of travel time increase as a result of a traffic control device, in this case, the traffic signals. This value is the average amount of time that the timing plans added to a traveler’s trip. The results, presented in Figure 39, showed a consistent decrease in delay for the weather responsive timings. The AM peak timing plans experienced a 17 and 10 second reduction in delay for westbound and eastbound traffic, respectively. The best improvement was observed for westbound traffic in the PM peak simulation, with a 23 second reduction in delay for the weather responsive timing. The eastbound traffic in the PM peak experienced about an 8 second decrease in delay.

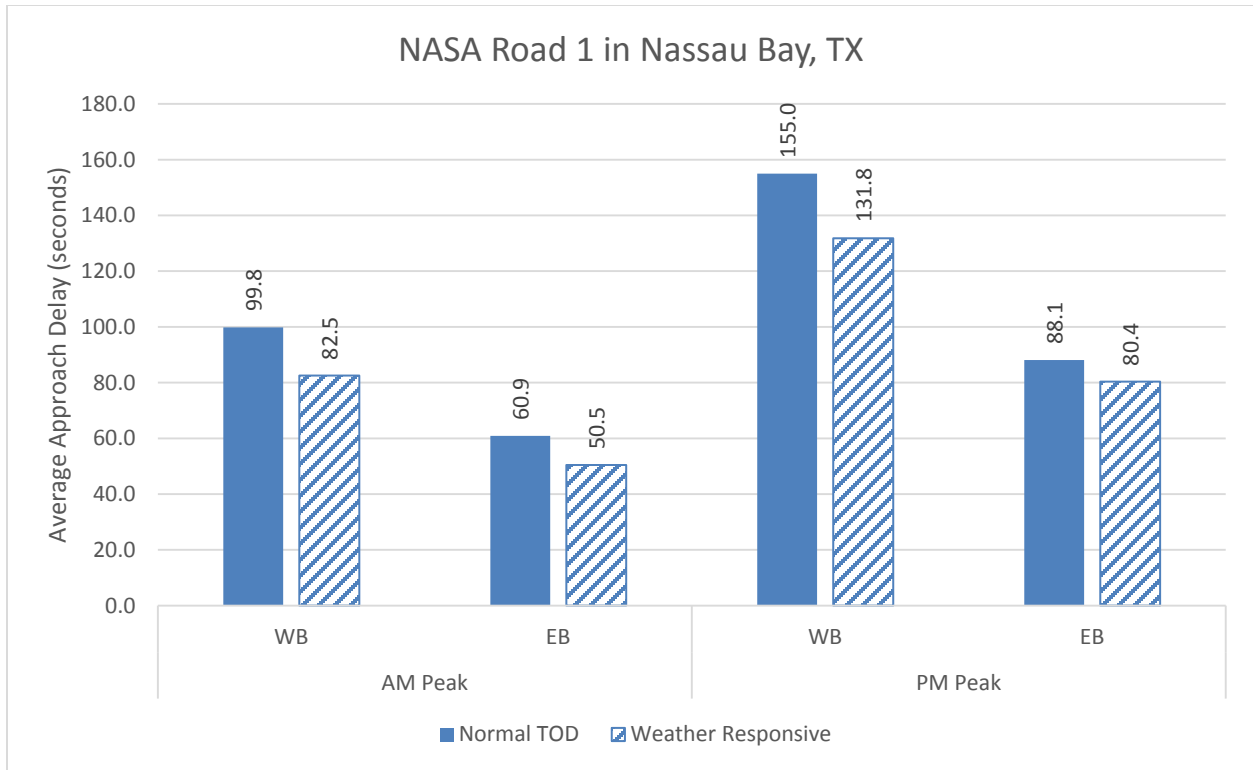

Figure 39. Average Approach Delay – NASA Road 1 in Nassau Bay, TX.

Average Stop Delay. Researchers observed the average stop delay for the eastbound and westbound directions of travel along NASA Road 1. The stop delay is the amount of time the vehicle spends stopped on the corridor, defined by traveling less than 3 mph. Figure 40 shows the average stop delay.

The weather responsive timings displayed consistent improvement over the normal TOD timings for average stop delay. The westbound direction showed more improvement than the eastbound direction in both AM and PM peak periods, with a 9 second and a 16 second reduction in delay, respectively. The eastbound direction did not show as much improvement between the two timing plans. The weather responsive timings showed a 5.7 second improvement for the AM peak period and a 2 second improvement for the PM peak period.

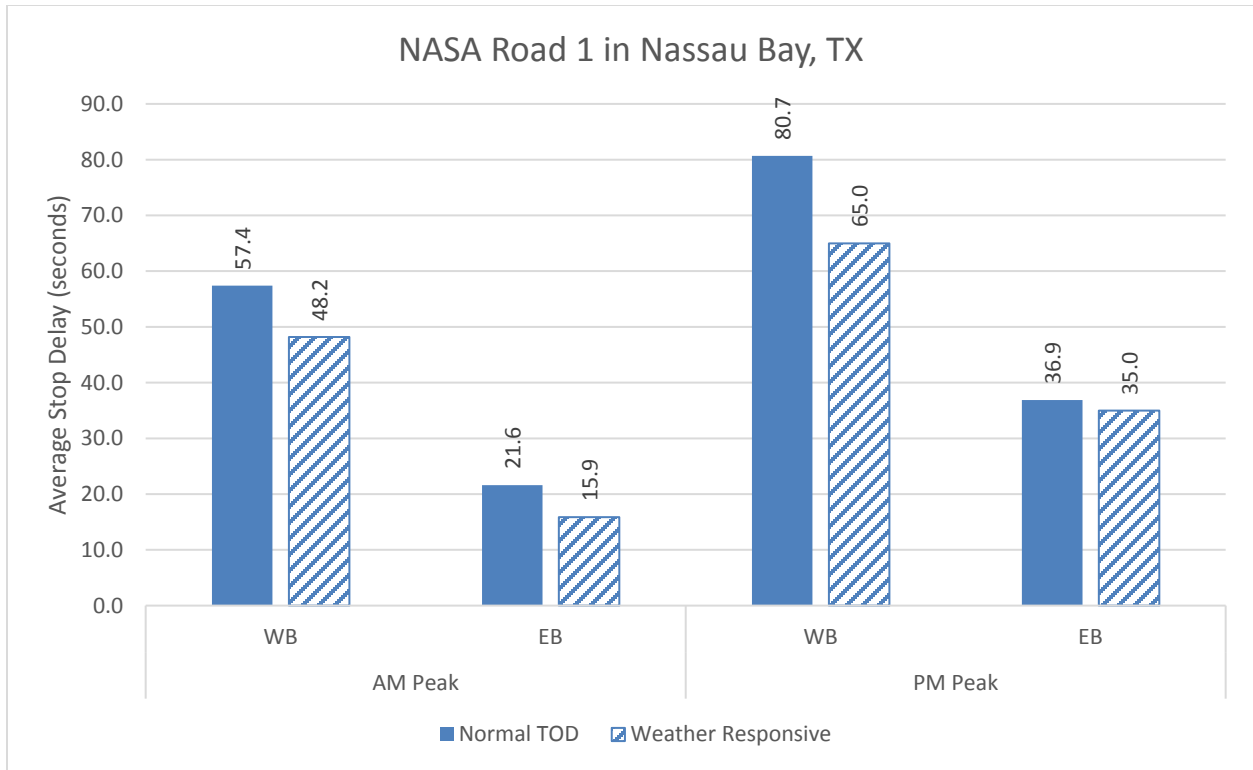

Figure 40. Average Stop Delay – NASA Road 1 in Nassau Bay, TX.

Average Number of Stops. The average number of stops for each vehicle traveling through the corridor presented some of the best improvement, shown in Figure 41. The westbound direction of travel showed the best improvement for the weather responsive timings over the normal TOD timings in both AM and PM peak periods. Westbound traffic experienced 0.5 and 1.1 fewer stops in the AM and PM peak periods, respectively. Eastbound traffic also experienced fewer stops with the weather responsive timings with 0.4 and 0.2 fewer stops for AM and PM peak periods, respectively.

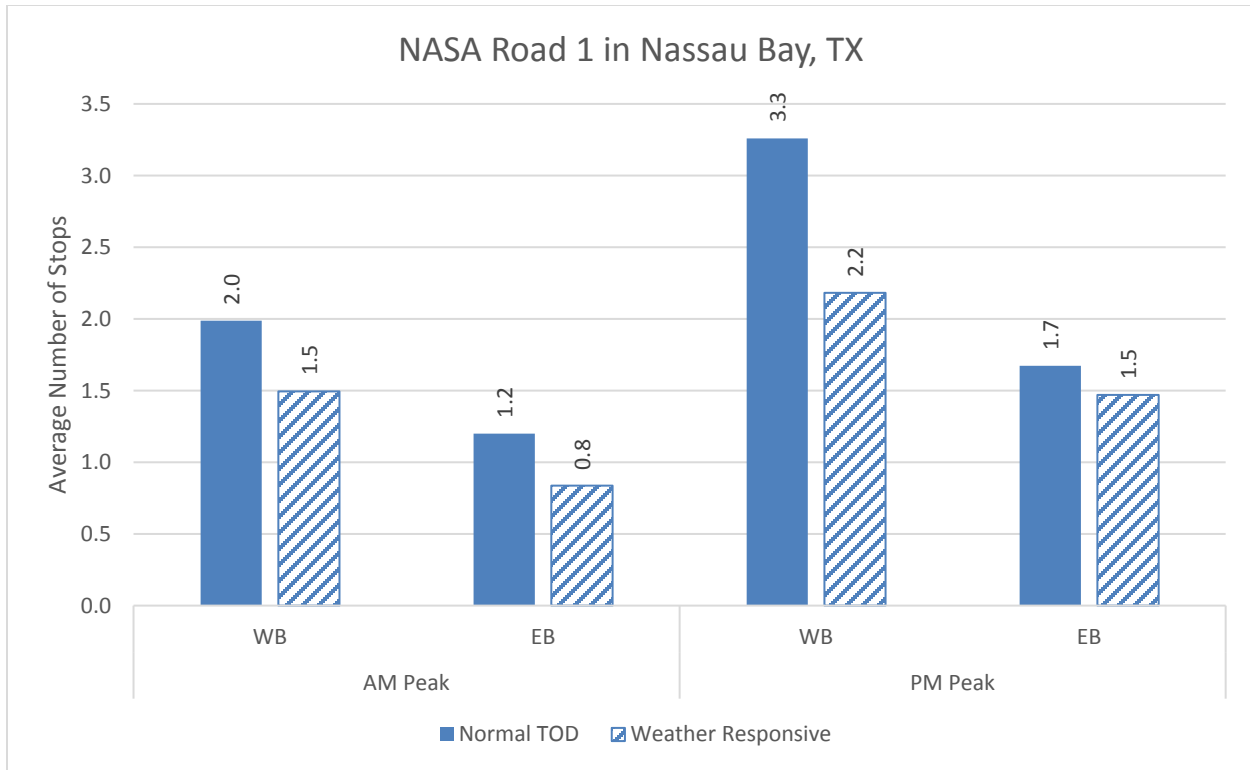

Figure 41. Average Number of Stops – NASA Road 1 in Nassau Bay, TX.

Intersection Analysis

This analysis involved looking at the intersections individually to see what improvements each intersection might experience from the weather responsive timings. The measures of effectiveness for this part of the analysis were the maximum queue length and the number of queue stops at each intersection. The inner intersections were targeted in order to remove the random arrivals from the vehicles entering the network, so this analysis focused on St. John Drive, Upper Bay Road, Saturn Lane, and Point Lookout Drive.

Maximum Queue Length. The maximum queue length is the largest queue observed during the simulation for each intersection. Figure 42 presents the maximum queue lengths for a significant weather event during the AM and PM peak periods. The largest queue lengths for the AM peak period are consistently smaller for the weather responsive timings than normal TOD, often on the order of 50 or more feet. However, the PM peak period yields mixed results. The westbound traffic for St. John and the eastbound traffic for Point Lookout experienced a smaller maximum queue but all of the other intersections experienced an increase in maximum queue. Further calibration of the weather responsive timing plan could reduce the maximum queues.

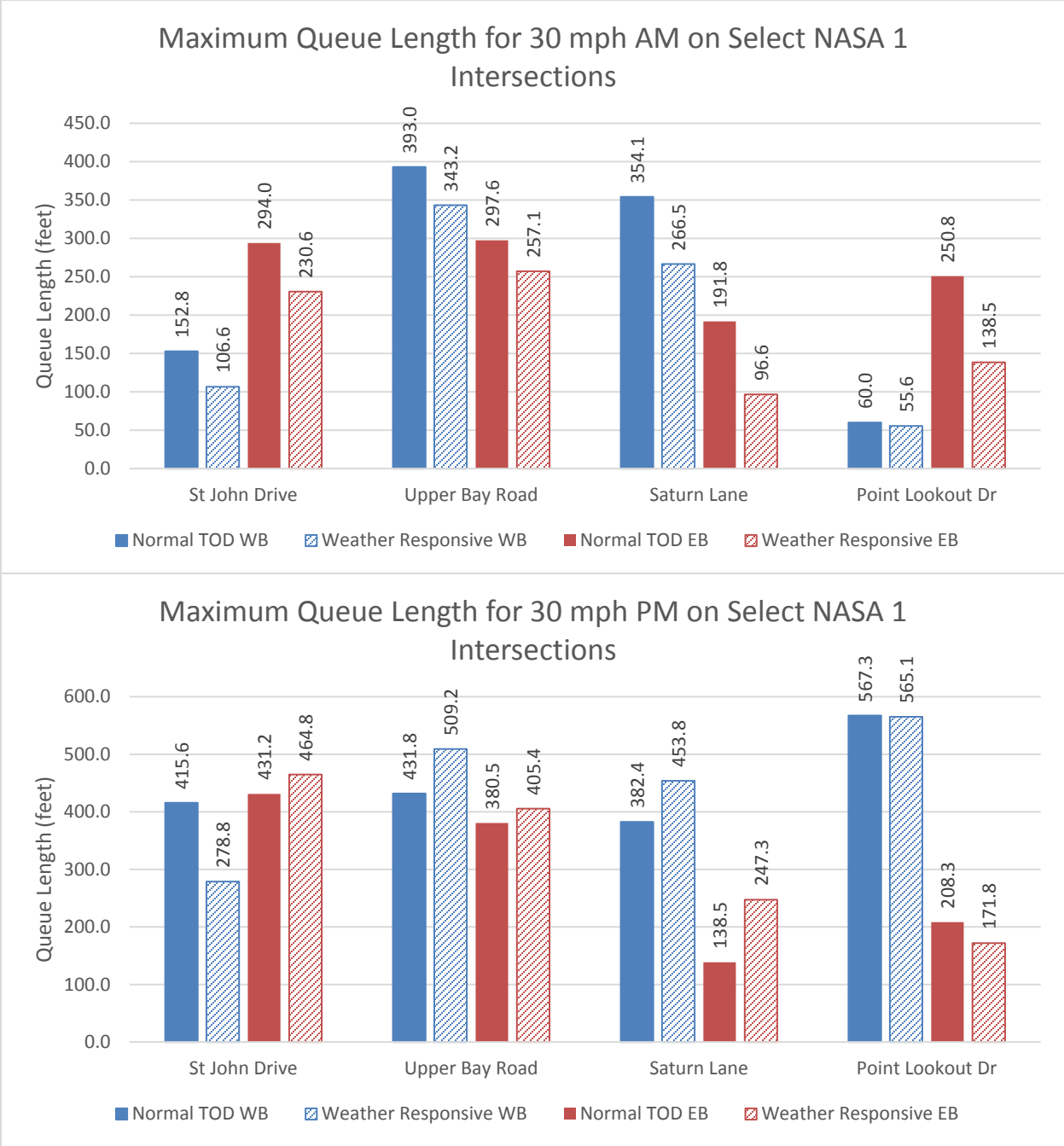

Figure 42. Maximum Queue Lengths – NASA Road 1 in Nassau Bay, TX.

Queue Stops. The queue stops are the total number of times any vehicle stops while waiting to get through the queue. For example, if a vehicle stops in the queue for the respective intersection three times before clearing the intersection, it would add three queue stops to the total number of stops for that simulation. A stop is defined by a vehicle traveling at 3 mph or less. Figure 43 presents the number of queue stops for each intersection in the two periods simulated. With the exception of Saturn Lane in the PM peak period, the queue stops for the weather responsive

timing are approximately less than or equal to the normal TOD timings across all directions and periods.

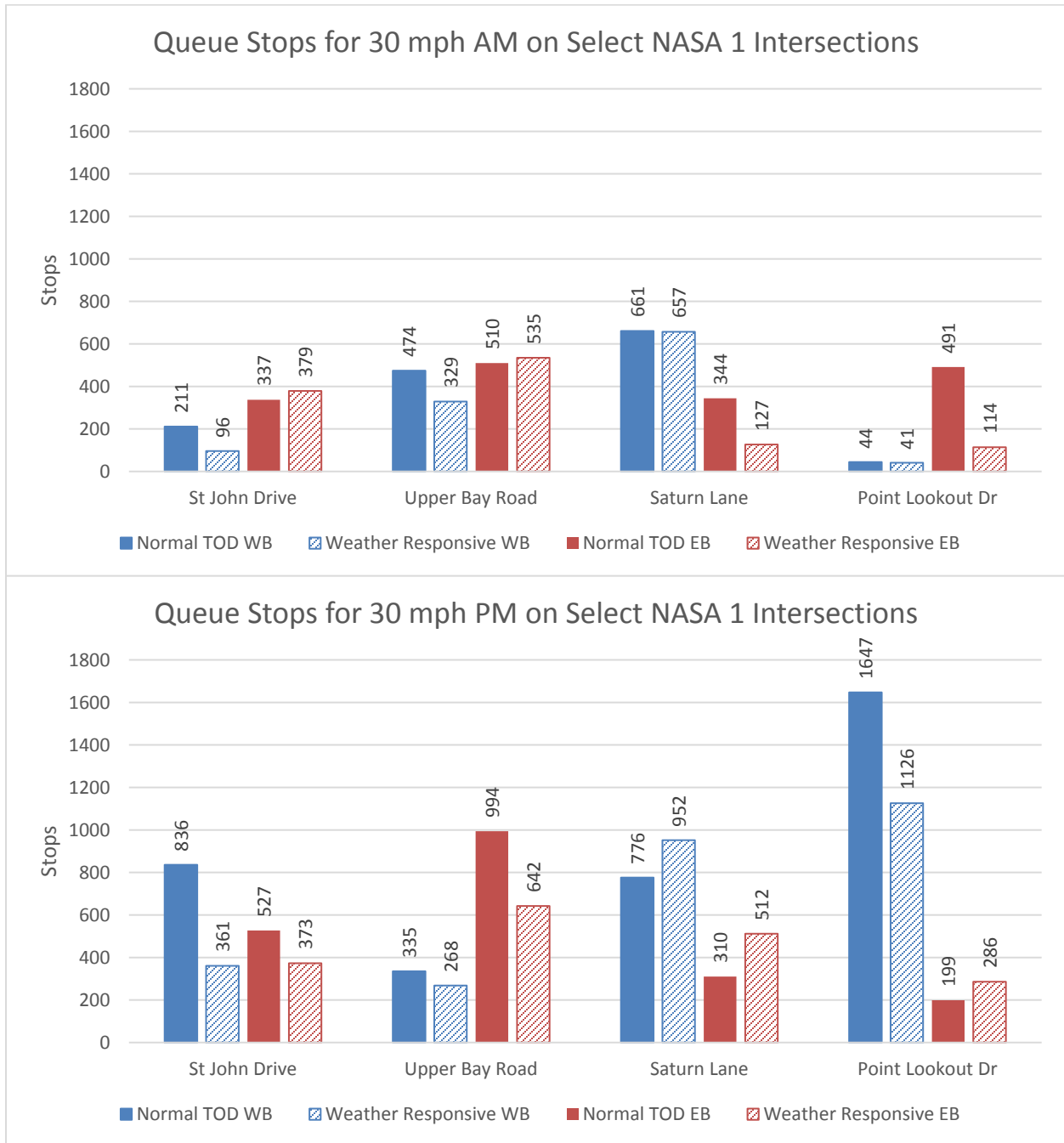

Figure 43. Queue Stops – NASA Road 1 in Nassau Bay, TX.

LESSONS LEARNED AND IMPLEMENTATION GUIDELINES

The following contains a summary of the lesson learned based on the field deployments and guidelines for implementing weather responsive traffic signal timing in Texas.

Weather and Pavement Monitoring Equipment

This section highlights lessons learned and implementation guidance related to the selection and deployment of the weather and pavement monitoring equipment:

- Pavement monitoring systems need to be deployed in such a way so as to measure actual travel conditions on the roadway. Ideally, these sensors should detect conditions in the wheel path of the primary travel lane. If deployed at an intersection, the sensor should be pointed at the departure side of the intersection, if possible, and outside of the crosswalk. It is not uncommon for pavement area outside of the wheel path to remain damp while the wheel path is generally dry.
- Weather stations are not a necessary part of a weather responsive traffic signal system deployment. While a weather station can provide supplemental information that can allow a signal operator to better understand the prevailing travel conditions, it does not provide any direct input into the decision-making process. Many pavement monitoring systems can also provide an indication of the air temperature. One exception to this recommendation is if a district would install a weather responsive system where wind speeds and gusts measurements are a direct input to the decision-making process.
- At the NASA Road 1 site, it was assumed that a weather responsive timing plan would be needed for low visibility conditions; however, the in-field visibility did not drop to the threshold that might impact traffic operations. The visibility sensors are costly and, in this case, never caused the system to implement new timing plans. Before deploying the sensors, a benefit-cost and risk analysis should be performed to determine whether installation of these sensors justifiable.

Weather Responsive Traffic Signal Timings

This section highlights lessons learned and implementation guidance related to the selection and deployment of signal timing strategies for weather responsive signal operations:

- Weather responsive traffic signal timing plans should be implemented only at critical intersections or systems where traffic operations are severely impacted by weather events. These intersections typically are high volume, high speed intersections whose operations are severely impacted due to reduced speeds. From an operational point of view, low volume/low speed intersections generally will not benefit from a weather responsive signal timing plan.

- Weather responsive traffic signal timing plans generally need to be robust (meaning applicable for a wide range of conditions). The impacts of weather on traffic operations can vary widely from intersection to intersection, from season to season, and from event to event. An ideal weather responsive timing plan is one that is applicable for a wide range of conditions.
- Weather responsive timing plans should not vary significantly from the existing timings plans. The splits for the timing plans should be close to the existing timing plans since traffic patterns may still continue to be similar to a normal day especially during the peak periods. Second, the operating agencies are hesitant to implement timing plans that significantly differ from normal TOD timing plans without adequate data to support it. Hence, modification should generally be limited to changes in offsets and phasing sequences to account for variation in travel speeds.
- Generally, districts are hesitant to change vehicle change (yellow) and vehicle clearance (all-red) intervals during weather conditions; the reason most often cited is a limitation of the technologies (it is not possible to change these intervals on the fly). Some traffic signal technology vendors now have a feature that allows variation in vehicle change and clearance intervals by selecting another plan. This feature could be used to make changes to (i.e., lengthen) the vehicle change and clearance intervals to accommodate slow travel speed during adverse weather conditions. Further research is needed to determine what, if any, human factor issues could occur as a result of changing these intervals for different types of weather responsive traffic signal timing plans.
- Agencies interested in deploying weather-responsive traffic signal control should conduct pilot studies to assess the impacts of various levels of adverse weather conditions on traffic flow characteristics in their jurisdictions. The objective of such a study would be to determine if any routine adverse weather events result in significant impacts (in terms of severity and extended duration) on traffic flow characteristics. If justified, these data could be used to develop alternate weather responsive timing plans.

System Deployment and Calibration

This section highlights lessons learned and implementation guidance related to deployment and calibration of weather responsive signal operations:

- Because no two weather events are exactly alike, it is difficult to develop firm activation thresholds for the pavement monitoring systems. An extensive set of data is needed to correlate traffic operations, traffic signal performance, and weather conditions together to develop good thresholds for determining when to activate the system.
- Generally, the research team recommends that two factors—pavement surface status and friction factor—be used to activate weather responsive signal operations. Pavement surface status (an indication of the general status of the condition of the pavement surface

[dry, icy, wet, etc.]) provides additional information that is useful in determining when to activate the weather responsive signal operations.

- When such systems are deployed, the thresholds for activating/deactivating weather responsive timing plans should be calibrated in the field.

Evaluation of System Performance

This section highlights lessons learned and implementation guidance related to the evaluating the performance of weather responsive signal operations:

- Evaluating the effectiveness of a weather responsive system can be difficult. It is difficult to assess the degree to which modifying signal operations provides a benefit during weather conditions.
- Weather conditions and driver behavior can vary widely across the state. A strategy that works in one location may not always work in other parts of the state. TxDOT districts will need to deploy these systems on an individual district by district basis.
- This project has demonstrated that weather-responsive signal systems can be deployed using existing off-the-shelf technology. However, further field-study based research is needed to determine how to determine when and where such systems should be deployed and how to properly evaluate their performance.
- Finally, evaluation cannot only be based on conventional measures of effectiveness such as reduction in travel time and reduction in delay. These parameters are expected to increase during adverse weather conditions. Performance measures should focus on measuring improvements in safety and minimize disruptions in travel such as minimizing unexpected stops.

CHAPTER 6. SIGNAL TIMING STRATEGIES AND PRACTICES DURING LARGE-SCALE WEATHER EVACUATIONS

The research team completed a literature review on signal operations and signal timing during hurricanes. In addition to reviewing literature, the research team also reached out to TxDOT and other cities, counties and municipalities to document current signal operations and timing practices during a hurricane.

BACKGROUND

Following the aftermath of Hurricanes Katrina and Rita in 2005, the Texas Governor (at the time Governor Rick Perry) oversaw the Task Force on Evacuation, Transportation and Logistics. The task force provided a final report to the Governor in February 2006 detailing 20 recommendations on various subjects related to hurricane evacuation and its logistics (4).

In almost parallel with the Governor's Task Force, TTI conducted research and prepared a report titled *Recommended Practices for Hurricane Evacuation Traffic Operations* (5). This research was conducted under the supervision of a TxDOT panel consisting of staff from the hurricane prone districts: Houston, Beaumont, Yoakum, and Corpus Christi. In this report, TTI discusses pre-hurricane and post-hurricane operations, operating signals in flash, stop time switches with officer control, and with evacuation signal timing plans.

There may be some benefit in developing evacuation signal timing plans, as it has the potential to reduce the demand for law enforcement officers at signalized intersections. The report suggests that with successful evacuation signal timing plans in place, law enforcement could be deployed to more critical evacuation routes, while lower priority routes could be operated with evacuation signal timing plans.

However, the study's resulting recommendations concerning traffic signals from the report are not only void of recommending establishing pre-hurricane evacuation signal timing strategies, but only provide recommendations for successful flash and stop time switches with officer operation.

Building on this TxDOT research and the potential benefits of hurricane evacuation signal timing plans, the research team investigated and determined recommended strategies for signal operations and timing during hurricane evacuations.

METHODOLOGY

To investigate and determine recommended strategies for signal operations and timing during hurricane evacuations, the research team performed the following:

- Conducted a state-of-practice literature review on signal operations and timing during hurricanes evacuations.
- Developed case studies of hurricane evacuation signal operations and timing in hurricane prone areas.

Case Studies

Based on the findings from the state-of-practice literature review, researchers selected several case studies to present in this technical memorandum. The case studies were developed using three sources of information:

- Literature.
- Literature and follow-up agency interview.
- Agency interview.

In addition to focusing on specific agency implementation of hurricane evacuation signal operations and timing, researchers also developed case studies for specific roadway characteristics (urban corridor vs. frontage road) and for evacuation patterns (unidirectional vs. multidirectional).

Case studies were developed with a specific set of elements including:

- Study/implementation area.
- Evacuation scenario.
- Origin-destination considerations.
- Signal timing methodology.
- Expected outcomes/actual results.
- Interagency considerations.
- Other considerations.

Recommending Strategies

The research team used the literature review and case studies to develop hurricane evacuation signal timing recommendations.

STATE-OF-PRACTICE LITERATURE REVIEW

Evacuations are dynamic in nature and to be successful, generally require significant planning, well-trained personnel, and a cooperative evacuee. There are generally two types of evacuations: short-notice (hurricanes) and no-notice evacuations. Both evacuation types create increased demand on the existing transportation network (6). This cannot be illustrated better than reviewing the images of evacuation during Hurricane Rita, when an estimated 2.5 million people attempted to leave the Houston region in 2005 (7) (see Figure 44).



Figure 44. Image of Hurricane Evacuation prior to Hurricane Rita.

It has been established that the different evacuation types produce different behavioral responses and corresponding evacuation demand (8). Optimizing signal timing, especially for hurricane evacuations, is a by-level problem. The sublevel is the prediction of traffic distribution and assignment, so signal timing, the main problem, can be optimized (9). Under non-evacuation operations, data can be collected to solve the sublevel problem of distribution and assignment. For hurricanes, planners must rely on two sources of traffic data: those from evacuation demand models and perhaps, if collected, past data from previous evacuation events.

Human Behavior, Demand, and Simulation

It is safe to state that no two hurricane evacuations are alike. The size of the storm, length of notice, and storm path all impact the evacuation demand. As discussed earlier, the by-level problem of optimizing traffic signal timing during hurricanes depends on the accuracy of traffic distribution and assignment data. For the purposes of this report, the researchers assumed that there are many tools and models that can be used to assist in developing evacuation demand data for simulation. However, the primary focus of the effort was the successful use of signal operations and timing for improved evacuation and these were not studied in detail.

Much research has been conducted on human behavior, evacuation travel demand, and evacuation routing. In addition to this research, there has been numerous simulation models created for evacuation including NETVAC, DYNEV, MASSVAC, TEDSS, REMS, OREMS, TEVACS, and CEMPS. There have also been several instances where off the shelf simulation software has been used including CORSIM, Paramics, NETSIM, MITSIM, Dynasmart-P, and VISSIM. The first work of this type to consider signal timing in an evacuation came in April 2004 by Sisiopiku (8). However a thesis by Gu in January 2004 discussed the potential benefits of modifying signal timing green time for evacuation (10).

Simulated Signal Timing Adjustments for Evacuation

Gu simulated the evacuation of the Blacksburg, Virginia, campus of Virginia Tech using TRANSIMS (10). TRANSIMS is unique in that it models activity of persons versus vehicles. The study evaluated five evacuation scenarios, including two scenarios where intersection operations and signal timing were implemented. The study only briefly gives an example of increasing the green time at the intersection of Roanoke Street and South Main from 15 to 25 seconds. The study later concludes that there was a 25 percent improvement in clearing time. No direct evaluation of the signal timing was completed.

Sisiopiku et al. (8) took existing evacuation and response plans for a medical center in Birmingham, Alabama, and completed a microscopic simulation in CORSIM. Researchers developed optimized signal timing plans for intersections near the medical center in Synchro and placed them in the CORSIM model. Performance measures such as travel time and delay time were compared under four different operation cases. Results showed that there were significant savings in travel time, delay, and speed with the optimization of the traffic signals (in case 3) based on the expected demand from the evacuation. However, there were no details provided on changes to operations, cycle length, green time etc., requiring the reader to assume all timing parameters were optimized in the study.

One of the most robust studies on signal timing during evacuation was completed in 2005 by Chen (6), presumably building off of a master's thesis of the same title (11). This study investigated the impacts of signal operations and timing along two Washington, D.C., evacuation routes using simulation. A CORSIM model was created using demand from two potential master scenarios: no notice evacuation involving a terrorist incident and a shutdown of federal offices forcing federal employees to return home. Three operation modes were evaluated including regular operations, Yellow-Red (YR) flash, and All Red (4R). The researchers also varied timing plans for normal operations by deploying the PM peak, an evacuation specific timing plan with 240s cycle and four other plans increasing the green (as a percentage) for all approaches and increasing (as a percentage) the green time on the major street but keeping the minor green time the same.

The results of the simulation showed that YR operation was the most efficient operation for evacuating from Washington, D.C. This operation simply permits more vehicles to evacuate from the area. However, this efficiency is created at the expense of side street delay and the potential for instances of non-compliance. Comparing this operation to 4R, an operation that provides equality to all approaches, 4R was found to be the least efficient of all operations studied. It was also discovered that the 240s evacuation timing plan performed better than the PM peak. In general, researchers concluded that increasing the cycle length of the peak hour plan would improve throughput. However, the most significant gain would come from not just increasing all green times (as a percentage) but specifically the main street green times while

leaving side street times static. Another suggested, but not an evaluated approach, was a combination of YR at minor intersection and increased cycle lengths at major intersections.

In a step toward the intersection of the by-level problems, Liu et al. (12) developed a corridor-based emergency evacuation system for Washington, D.C. This system, similar to the Decision Support Systems (DSS) (see Figure 45) one would see attached to an Integrated Corridor, includes five principle components:

- Input Module – for users to define evacuation scenarios, attributes, parameters, incidents, and adjustments.
- Database Module – Storage of data including scenarios, geometric features, intersection control, and outputs.
- Optimization Module – Generates optimized route choice, turning percentages, demand, and signal timing plans.
- Online Simulator – For the projection and visualization of traffic conditions.
- Output Module – For displaying outputs from simulation results.

The authors then developed a case study for Union Station (Washington, D.C.) including a detailed evacuation scenario, a step-by-step action plan, and analysis of effectiveness. No comparison of pre-event to event signal timing was made. It is assumed that all timing parameters were optimized in the system.

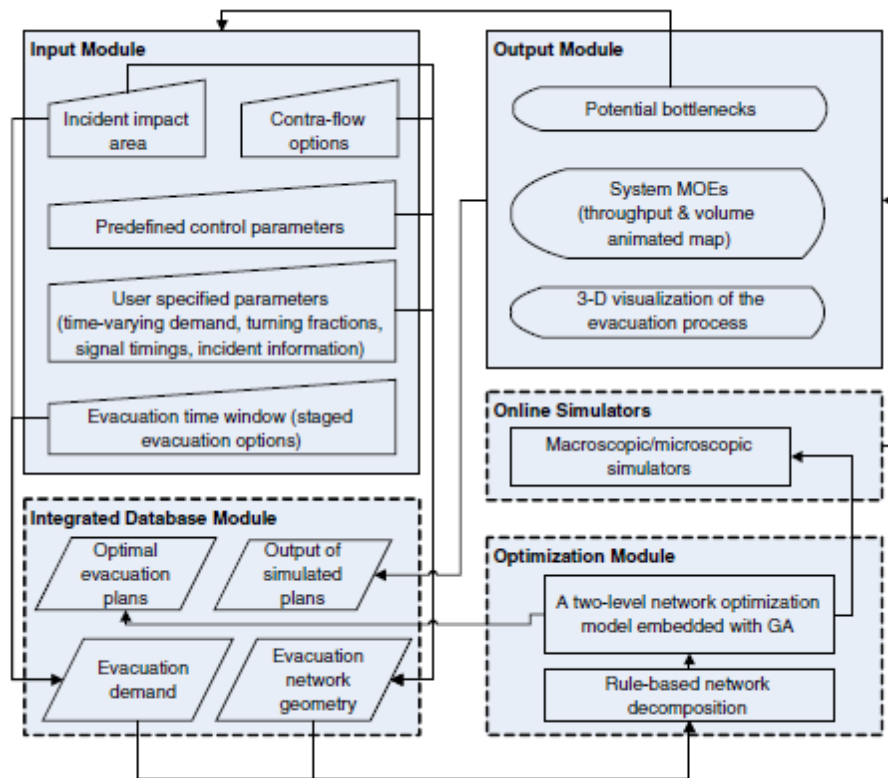

Figure 45. Washington, D.C., Proposed Evacuation Framework.

Dynamic programming was used to optimize critical intersections in a 2011 study of Washington, D.C., evacuation routes (13). Dynamic programming methodology locates the phase timings, through simulation, that optimizes the number of vehicles throughput at an intersection. This process is completed without the concept of predefined cycle lengths including maximum cycle lengths. A case study was prepared using actual data from the intersection of NW 7th Street and NW Pennsylvania Avenue in Washington, D.C. The evacuation scenario included a dirty bomb at the L'enfant Plaza Metro station. The important take-away from this study is that without a maximum cycle length setting, a 440 second cycle length was not superior to a 240 second cycle length.

Evacuation Signal Timing by Public Agencies

Conversations held in 2005 with the Virginia DOT and City of Norfolk both revealed that evacuation signal timing plans had been developed by those agencies (5). No details about the specific operations and/or timing were given. In 2005, as part of an FHWA study, nationwide interviews were conducted by Miller-Hooks (6) to determine the state-of-the-practice on evacuation signal timing. From the interviews, researchers determined that there are generally four practices:

- Police directing traffic at critical intersections.
- Setting the signals on flash.
- Setting the signals on the PM peak timing plan.
- Setting the signals to maximum cycle length (short duration on minor streets).

A list of agencies interviewed for this document was not available.

Signal Timing Strategies for Special Events and Incidents

Several other operational situations can be studied to gain insight to effective signal operations and timing including special events and incidents. The FHWA signal timing manual, particularly Chapter 9, suggests that green time be increased for preferred or diverted movements while other movements remain the same (14). Two example implementations discussed in the signal timing manual include Coordinated Highways Action Response Team (CHART) and the City of Portland.

Coordinated Highways Action Response Team – State of Maryland

CHART is a cooperative group between the Maryland Department of Transportation, Maryland Transportation Authority, and Maryland State Police with several other federal and local agencies. The CHART system is monitored by detectors and video cameras. Once an incident is detected, information is reported back to the stakeholders. This incident detection is integrated into the signal system software. Similar to a DSS, a message about pre-set timing plans is triggered for stakeholders to implement if necessary.

City of Portland

The City of Portland, along with the Oregon Department of Transportation, has pre-defined diversion plans for incidents. Once a diversion plan is triggered, signal timing along the adjacent arterials are modified to handle the additional traffic.

TEXAS CASE STUDIES

The research team investigated several Texas based evacuation signal timing implementations and developed case studies for inclusion in this technical memorandum. The only two case studies developed at this time are for the City of Pasadena and TxDOT Incident Response System on I-10 in Houston. There may be several more developed as public agencies are identified and contacted in the future.

City of Pasadena, Texas

In 2013, the City of Pasadena completed a City-Wide Hurricane Signal Timing Study using Texas General Land Office funding to enhance its ability to respond to hurricanes.

Study/Implementation Area

The City of Pasadena is bound by I-45 and I-10 on its west and north, respectively. Within the city, there are 141 traffic signals (2013), with 38 of them communicating through wireless radio, all owned by the City of Pasadena (see Figure 46).

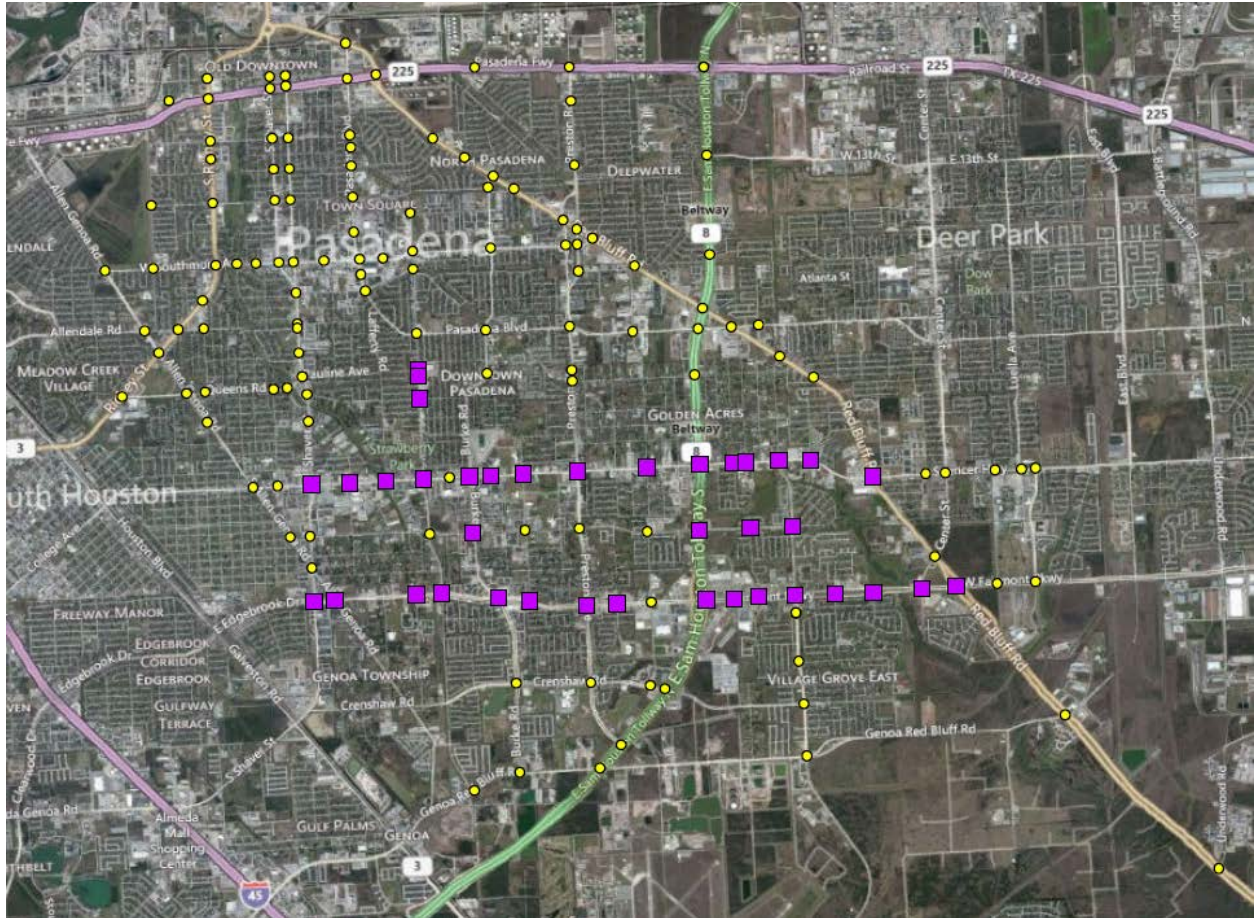

Figure 46. Pasadena Study Area.

The City of Pasadena’s Emergency Management Department has a siren system with announcement capability to guide the public directionally during emergencies. In addition, citizens can subscribe to the City’s Nixle Short Message Service text message service to stay informed on emergency events, weather warnings, and community updates.

Evacuation Scenario

Pasadena study timings were developed under the assumption that a hurricane would be approaching from the Gulf and residents would have 24 to 72 hours to evacuate. Due to the multiple freeways that bound the city, no directional evacuation routes were established. However, five routes for timing were selected:

- **SH 225** intersects with South Shaver Street, Red Bluff Road, Allen Genoa Road, and the East Sam Houston Parkway (Frontage Roads), which provides essential access during an evacuation. As an urban principal freeway and frontage road system, SH 225 mainlanes has a capacity between 60,000 to 200,000 vehicles per day (vpd) while its frontage road system has a capacity of 1,000 to 8,000 vpd, as an urban collector.
- **The East Sam Houston Parkway (Frontage Roads)**, a six-lane urban principal arterial freeway and expressway with frontage roads classified as urban principal arterial, with capacity between 60,000 to 200,000 vpd and between 30,000 to 45,000 vpd, respectively.
- **Spencer Highway** is a six-lane urban principal arterial with capacity between 30,000 to 45,000 vehicles per day. Spencer Highway provides access to the East Sam Houston Parkway (Frontage Roads) and Allen Genoa Road on the east side and west side of City of Pasadena, respectively.
- **Fairmont Parkway** is an urban minor arterial with capacity between 4,000 to 24,000 vehicles per day. The numbers of lanes change from four-lane between Allen-Genoa Road and Preston Road to six-lane between Preston Road and the East Sam Houston Parkway (Frontage Roads).
- **South Shaver Street** is an urban principal arterial with a capacity between 30,000 to 45,000 vehicles per day. Shaver Street starts north of SH 225, with the Washburn Tunnel on the most northern side, then continues south through the traffic circle before going under SH 225 into the city.

Origin-Destination Considerations

In general, from a review of land use for the City of Pasadena, there were no clear origin-destination patterns other than trips originating at one's home and traveling to the nearest regional evacuation corridor such as BW 8, SH 3, SH 225, and I-45. However, it was assumed that there would be preparation type trips from home to retail or from work to home prior to evacuation.

Signal Timing Methodology

The recommended best practice for the development of evacuation signal timing was identified as being the extension of the green time on the PM peak timing plan, enabling a longer cycle length with a majority of green time given to the evacuation approaches. This was expected to have minimal impact on the minor street, while moving evacuees out of the area.

Based on the research the city's consultant adopted, the following methodology for development of evacuation traffic signal timing plans:

- The existing roadway system was created in Synchro 8 based on the available aerial maps and field data. To limit confusion, it was anticipated that the speed limits would not vary

during evacuation, so the posted speed limits were used for traffic progression along the evacuation corridors.

- The existing PM peak hour timing plan from the city was used as the base for proposed evacuation signal timing plan. It was expected that the existing signal timing plan provided good traffic progression along the selected corridors under current conditions. Therefore, the longer cycle length would also result in a reasonable traffic progression under evacuation conditions where higher traffic volumes along the evacuation corridors were anticipated.
- To create an evacuation timing plan, 30 seconds were added to the existing PM cycle length of each signal to provide additional green time for the through movements along the evacuation corridors. The additional 30 second cycle length was expected to maintain an acceptable level of delay for minor street movements as decided by the city.
- The evacuation timing plan did not attempt to send vehicles in any particular direction but attempted to make it easier to travel in any direction along the evacuation corridor.
- The existing traffic volumes were not representative of operations during an evacuation, so reasonable dummy traffic volumes were used to aid in timing automation for finding bandwidth and creating new timings.

Expected Outcomes/Actual Results

Adding 30 seconds to the cycle lengths of the existing signal timings of evacuation corridor intersections provided extra green time to the major directional movements associated with each evacuation corridor. The additional 30 seconds added to the cycle lengths created an effective bandwidth along the evacuation corridors enabling an efficient and improved traffic progression. The goal of assisting the vehicles to travel reasonably unhindered in order to exit the City of Pasadena during an emergency evacuation situation is expected to be achieved by adopting the evacuation corridor signal timing plans.

Interagency Considerations

Along the borders of the city limits, there are 17 traffic signals owned by other agencies namely South Houston, Deer Park/La Porte, Harris County, and City of Houston. Therefore, it was determined important for the City of Pasadena to communicate and coordinate with these agencies on the development of the evacuation signal timing plan to avoid bottlenecks at those intersections during evacuation. It is not clear whether this has been accomplished.

Other Considerations

Many of the selected corridors did not have wireless communication, which would force the agency to manually implement the hurricane signal timings prior to evacuations.

I-10 Freeway Responsive System

In 2014, the TxDOT Houston District developed the I-10 Freeway Responsive System to help alleviate freeway traffic through the signalized intersections on frontage roads when the freeway traffic level of service deteriorates. Essentially, there are sensors that detect deteriorating level of service on the I-10 corridors, which then automatically deploy adjusted signal timing plans on the adjacent frontage road.

Study/Implementation Area

The implementation area is along I-10 between SH 6 and SH 99 (Grand Parkway) in Houston, Texas (see Figure 47). The diamond interchanges that see modified signal timings plans include I-10 at the following locations:

- Barker Cypress Road.
- Greenhouse Road.
- Fry Road.
- Westgreens Boulevard.
- Mason Road.

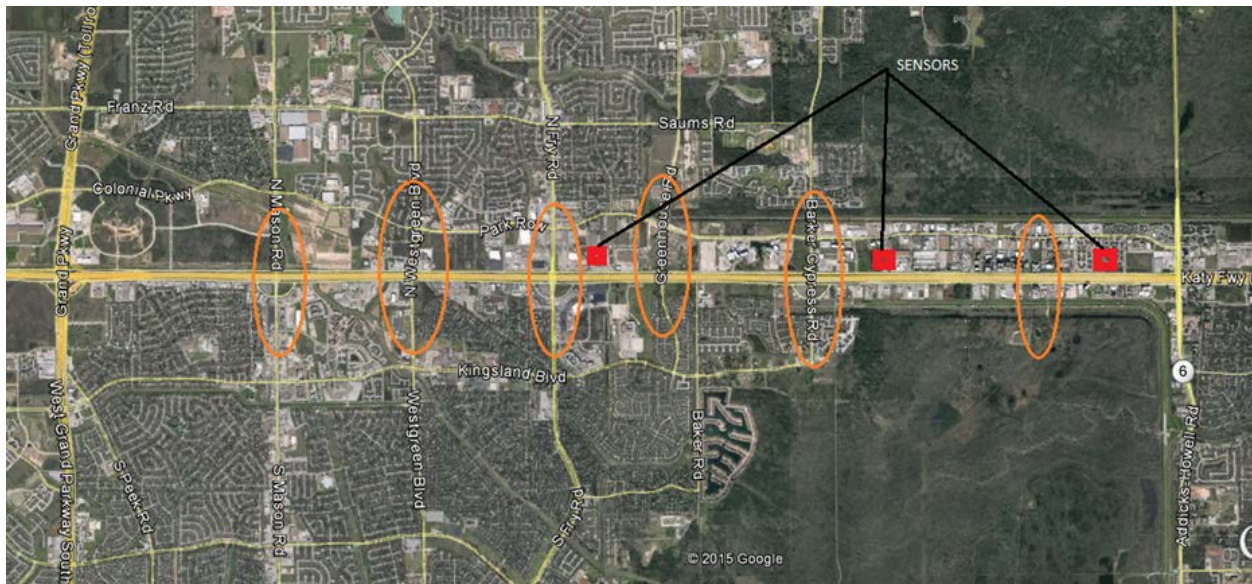

Figure 47. I-10 Freeway Responsive System Map.

Evacuation Scenario

In this case, the applicability during a hurricane is the system's ability to detect freeway deterioration and implement modified signal timing plans along the frontage road (see Figure 48).

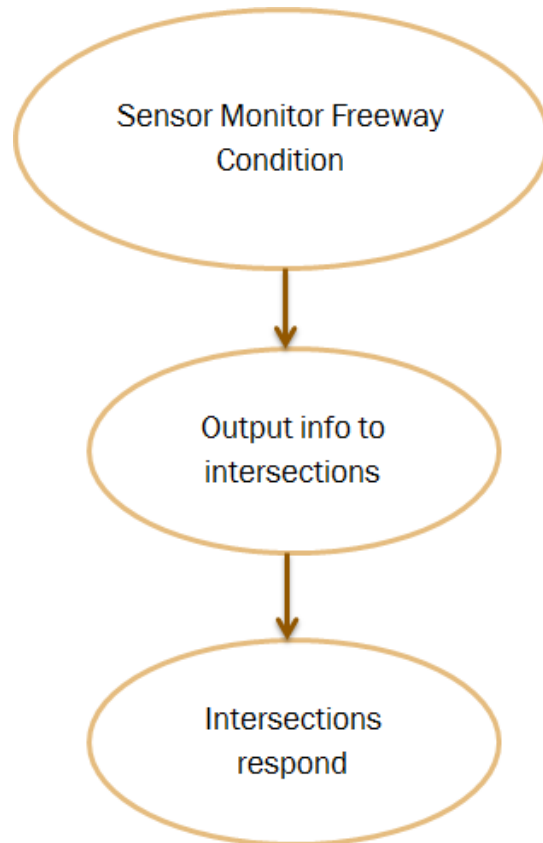

Figure 48. Freeway Responsive System Framework.

Origin-Destination Considerations

The origin-destination considerations are limited to the direction of travel but would primarily activate in the east-to-west direction during a hurricane evacuation. I-10 is an established evacuation route.

Signal Timing Methodology

TxDOT is using Wavetronix Radar Sensors to monitor freeway vehicle speed, volume/occupancy in both direction of freeway, to determine periods when the freeway operation breaks down (see Figure 49). This breakdown results in an increase in the number of vehicles using the adjacent frontage roads and traveling through signalized intersection timed for normal operation. Using a contact closure radio system to send contact signals to frontage road signal cabinets, timing plans can be implemented automatically.

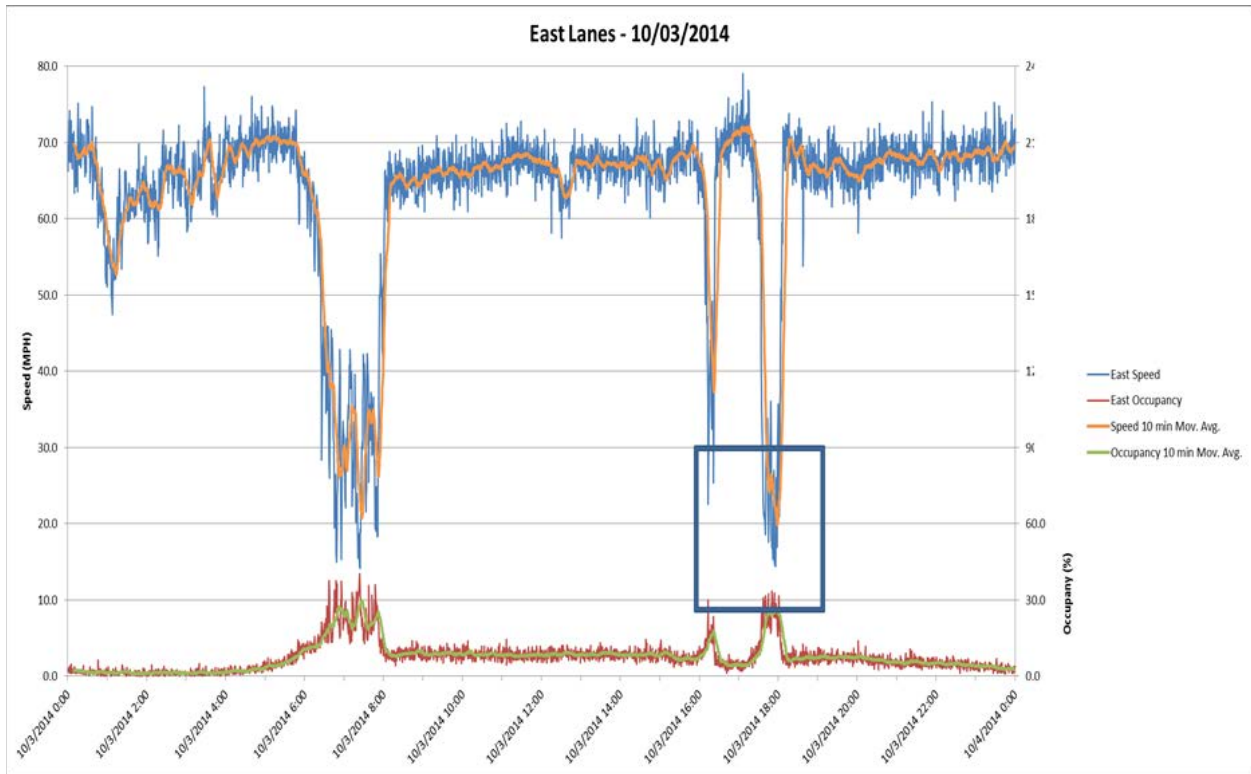

Figure 49. Illustration of Freeway Travel Speed Deterioration.

Equipment used to accomplish this includes a Wavetronix HD Sensor with Criteria Signaling Feature, Click! 513 Contact Closure, a Intuicom 900 MHz radio with I/O Contact Closure, and the existing Econolite ASC 3 Traffic Signal Controller (see Figure 50).



Figure 50. Image of Contact Closures and Radio.

The Wavetronix sensors are setup for number of lanes and directions while the contact closure interval criteria setup includes speed, volume, and/or occupancy. These work with the radio that must be programmed for contact closure inputs and outputs at sensor location and traffic signal cabinet.

The equipment works together to implement pre-defined traffic signal timing plans. The adjustment to signal timing plans include a simple 20 second increase in green time for the frontage road through movement, increasing the cycle length by the same amount. Three timing plans can be generated by using two contact inputs:

- On-off plan 1 (inbound condition).
- Off-on plan 2 (outbound condition).
- On-on plan 3 (both).

Expected Outcomes/Actual Results

TTI researchers assisted TxDOT with simulating the potential benefits of implementing modified timings during threshold periods of freeway congestion. A VISSIM model was developed with a focus on the Barker-Cypress intersection and frontage road approaches, as well as the main lanes between SH 6 and Mason Road in the westbound direction and between SH 6 and Greenhouse Road for the eastbound direction. Barker Cypress is the first TxDOT maintained signal west of SH 6.

Performance measures included PM peak hour throughput (freeway, frontage, and side streets), delay of approaches, freeway delay, and intersection delay.

Results from the simulation of the PM peak show a throughput increase of 500 vph on the freeway, 380 vph on the effected frontage road, and a 115 vph decrease on the unaffected frontage road and cross street. Delay decreased by 64 veh-hour on the freeway, 130 s/veh in the effected direction. Side street delay increased by 62 s/veh but overall the system reduced intersection delay by 68 veh-hrs.

One interagency concern could be with the adjacent signals, if those maintaining agencies wish to participate in the system. TxDOT is planning on completing a sensitivity analysis for the system soon.

RECOMMENDED SIGNAL TIMING STRATEGIES DURING HURRICANE EVACUATION

In summary, multiple methodologies have been discovered as potential signal timing strategies for hurricane evacuations (without officer) including:

- YR flash.
- Increase Cycle Length/Increase Green Time for All Approaches (CL/AA).
- Increased Cycle Length/Side Street Green Time Remains the Same (CL/SS).
- Signal timing plans using estimated evacuation demand.
- All red flash (4R).

For Maximum Vehicle Evacuation

It was clearly demonstrated that deploying a YR signal operations is the most efficient for moving vehicles through a network of signals (6). However, it is unknown how compliant side street vehicles will be during an evacuation event. It has been suggested that in high stress situations drivers will be even less patient, potentially creating an unstable situation at major intersections. One suggested solution was to develop a YR-CL/SS hybrid where minor intersections are put on YR operations while major intersections are placed under CL/SS operation.

For High Efficiency and Acceptable Driver Compliance

The majority of literature (6, 10, 11) and case studies (Pasadena and TxDOT I-10) points to the implementation of CL/SS as a highly efficient signal timing strategy. This implementation provides increased green time for the evacuating approaches but still provides for side street ingress and is expected to reduce non-compliant drivers.

If Evacuation Demand Is Known

Developing optimized signal timing plans based on a prediction of evacuation demand has been shown to improve operations during evacuation (8). However as demonstrated in the Chen (6) study, it would be recommended to have additional timing plans to account for additional demand, including taking optimized plans and developing additional CL/SS timings.

For Quick Implementation

If there is a need to quickly implement signal timing plans for improved operation, simply increasing the cycle length CL/AA can provide some benefit (5, 10). This benefit will not match or exceed CL/SS but can be implemented quickly.

Equitable Operations

Flashing Red on all approaches is the most equitable signal timing operation but is not recommended for efficient evacuation purposes.

ELEMENTS FOR FURTHER STUDY

It is clear that individual signal timing parameters were not investigated heavily in the literature. Parameters such as offset optimization, left-turn phasing, yellow and red clearance, and detection were not discussed. In addition to these elements, the need to establish an understanding of when drivers become uncompliant is needed to determine if YR operation can be successful in real-world situations.

CHAPTER 7. WEATHER RESPONSIVE SIGNAL TIMING GUIDELINES

This chapter provides guideless for developing and implementing weather responsive traffic signal timing plans. These guidelines focus on how to improve traffic signal operations during inclement weather events. These changes have the potential to reduce weather-related crashes and maintain efficiency at intersections and corridors during weather events. This guidelines were developed to be integrated into TxDOT *Traffic Signal Timing Handbook*.

This chapter consists of four parts. The first part provides an overview of the factors that may require weather responsive traffic signal timings. The second part of this appendix presents the concepts that can be considered for implementing the weather responsive traffic signal timings. The third part summarizes the procedures used to develop weather responsive traffic signal timing plans at intersections and corridors. The last part provides guidelines for determining the appropriate advanced weather signal timing settings for the subject intersection or corridor.

OVERVIEW

Driver behavior is directly influenced by external conditions. When weather events occur, drivers' behavioral responses are reflected in traffic operations. In the presence of fog, for example, drivers may increase following distances or reduce travel speeds to compensate for reduced visibility. In wet conditions, drivers may reduce speeds to compensate for reduced pavement friction, or they may adjust their acceleration and deceleration rates to avoid a loss of traction. Table 20 provides a summary of the potential impacts of key weather-related events on roadway and traffic operations. These impacts may be severe enough, and of sufficiently prolonged durations, to require the implementation of alternate timing parameters or coordination plans to maintain safety and operational efficiency of isolated and closely spaced traffic signal systems.

CONCEPTS

This part of the appendix explains the basic concepts for implementing weather responsive traffic signal timings. Topics addressed include increasing vehicular red clearance intervals, increasing minimum green intervals, implementing phase recalls, and developing weather-responsive coordination plans.

Increase Vehicular Red Clearance Intervals

One strategy to reduce right-angle crash potential at signalized intersections is to increase the red clearance interval between conflicting movements. Extended red clearance intervals provide additional buffer time between conflicting movements. The extension allows errant vehicles (subject to reduced pavement friction) to clear the intersection before the transfer of right-of-way to another movement. The increase in red clearance time also provides additional time for pedestrians to clear crosswalks, which may be blocked due to snow accumulation.

Increase Minimum Green Times

As previously discussed, weather can affect start-up lost time and saturation flow rates on some intersection approaches, particularly those that experience substantial snow and ice accumulation. To account for increases in start-up lost time caused by weather, some agencies increase the duration of their minimum green times on the affected approaches. Through the provision of additional green time during weather events, practitioners increase the likelihood of queue clearance under degraded conditions. This strategy is commonly deployed on intersection approaches that are situated on upgrade slopes.

Table 20. Weather-Related Roadway and Traffic Operations Impacts.

Weather Events	Potential Roadway Impacts	Potential Traffic Operations Impacts
Rain, Snow, Ice, Sleet, Hail, and Flooding	<ul style="list-style-type: none"> • Reduced pavement friction • Lane obstruction and submersion • Reduced visibility • Infrastructure damage • Reduced detection capabilities • Road restrictions and closures 	<ul style="list-style-type: none"> • Reduced speeds • Increased speed variability • Reduced roadway capacity • Increased delay • Increased crash risk
Strong Winds	<ul style="list-style-type: none"> • Reduced visibility due to blowing snow/dust • Lane obstruction due to wind-blown debris and drifting snow • Reduced vehicle performance • Reduced detection capabilities • Bridge restrictions and closures 	<ul style="list-style-type: none"> • Reduced traffic speeds • Increased delay • Increased crash risk
Fog, Smog, and Smoke	<ul style="list-style-type: none"> • Reduced visibility • Reduced detection capabilities 	<ul style="list-style-type: none"> • Reduced speeds • Increased speed variability • Increased delay • Increased crash risk
Lightning and Extreme Temperatures	<ul style="list-style-type: none"> • Infrastructure damage 	<ul style="list-style-type: none"> • Traffic control device failure • Loss of power/communications

Source: (15)

Implement Phase Recalls

Weather can reduce the effectiveness of some vehicle detection systems, which can cause phases to be skipped even when demand is present. Ice cover on video detection cameras, for example, renders detectors inoperable, and fog conditions can limit the effectiveness of video detection systems. Similarly, snow accumulation can obstruct pavement markings and prompt detector error.

To mitigate this issue, some agencies place recalls on particular phases at known problem intersections prior to weather events. In the event that the detection system is rendered ineffective by weather, recalls ensure that phases continue to be served. Generally, this is done manually through remote access to the individual intersection controllers, although some video

detection systems have logic processes that place constant calls to phases when fog is detected. This strategy effectively places the intersection in fixed-timed operations. This strategy can limit the efficiency of operations, but will ensure that all movements are served throughout the weather event.

Weather-Responsive Coordination Plans

Many agencies activate special coordination timing plans during adverse weather conditions. The Utah Department of Transportation, for example, developed timing plans for use during considerable snow events. The timing plans were created primarily to help with snow plowing operations and to facilitate traffic flow on routes of major significance. Generally, the plans were designed to accommodate a 30 percent reduction in free-flow speed.

During snow events, on-staff meteorologists and traffic control center operators examine current weather and roadway conditions. They recommend locations and time periods for the implementation of weather-related timing plans based on the presence of one or more of the following conditions:

- A weather-related timing plan has been requested by a maintenance supervisor.
- The delay-causing portion of the weather event is expected to last more than 20 minutes.
- A significant reduction in travel speeds is detected due to weather conditions.
- A corridor is congested because of the weather event.

Because weather conditions can vary widely across a region, and even along different segments of the same roadway, weather-responsive coordination plans are implemented on a corridor-by-corridor basis. Different coordination plans may be implemented on particular corridors based on the TOD and on the intensity of the snowfall (e.g., moderate, heavy). Once a weather-related timing plan is implemented, the subject corridors are monitored via CCTV by operators. When special operations are no longer needed or effective, the operators disable the timing plans.

The Connecticut Department of Transportation has also developed weather-related timing plans that are implemented with major snow events. These timing plans adjust offsets and increase cycle lengths to accommodate slower travel speeds along corridors. Control center operators implement the timing plans based on visual observation of snowfall rates and traffic conditions.

PROCEDURES

The following outlines the general steps for developing weather-responsive traffic signal timings.

Step 1. Identify Operational Objectives

The first step in the process of developing weather-responsive traffic signal timing plans is to identify operational objectives. The objectives for signal timing will be different depending on if

a signal system is located in a rural, suburban, or urban environment. Objectives may be chosen based on known problems in the study area, as a result of public comments, staff observations, or known discrepancies with established policies. The identification of problems during timing analysis may be an iterative exercise done in conjunction with determining objectives. In other words, previous problems may help shape the operational objectives and/or, by clearly defining operational objectives, deficiencies may be more apparent and easily addressed. Objectives may also change by TOD or by traffic volume. Common weather-related signal timing objectives are as follows:

- Minimize potential stops on slick roadways.
- Maintain quality progression under reduced operating speeds.
- Minimize queue lengths and guarantee access from cross-streets.
- Minimize pedestrian exposure to inclement weather.

Step 2. Establish Performance Measures

Performance measures (also known as measures of effectiveness) should be selected for each operational objective to evaluate the success of the timing plan(s). Some objectives (such as pedestrian priority) may need to be assessed qualitatively, as the performance measures may be difficult to measure in the field or through most analysis tools. However, objectives should not be overlooked simply because they are not available through software applications. Some signal timing decisions may require a qualitative assessment.

Step 3. Assess Weather Impacts on Traffic Operations

It is important for district personnel to understand the impacts that weather conditions have on intersection operations. Table 21 summarizes more specific weather-related impacts that can directly affect signal timing. All of these factors, and more, should be considered when adjusting traffic signal timing.

Table 21. Weather-Related Signal Timing Impacts.

Impact Category	Weather-Related Impacts
Speeds	<ul style="list-style-type: none"> • Reduced vehicular travel speeds • Reduced bicycle speeds • Increased headways
Acceleration and Deceleration Rates	<ul style="list-style-type: none"> • Reduced vehicular acceleration rates • Reduced bicycle acceleration/deceleration rates • Increased start-up lost times
Flow and Capacity	<ul style="list-style-type: none"> • Reduced saturation flow rates • Reduced capacity
Safety-Related	<ul style="list-style-type: none"> • Increased potential for right-angle crashes
Detection	<ul style="list-style-type: none"> • Reduced detection capabilities

Source: (1)

Step 4. Develop Timing Strategies and Timing Values

Once operational objectives and their associated performance measures have been determined, the process continues with the development of signal timing strategies (i.e., minimizing cycle length or favoring arterial through traffic) and selection of appropriate timing values. Agencies may develop alternative timing plans or outline specific signal timing parameter changes to manage such weather-related impacts.

Step 5. Implement and Observe

The next step is implementing the signal timing values and making final adjustments to the timing parameters. This process can be difficult because weather events are often very unpredictable both in terms of their occurrence and impacts. Furthermore, when severe weather events occur, operations personnel are too often busy addressing troubleshooting issues and situations to observe special timing plans. Therefore, it is highly recommended that TxDOT use automated data collect tools to assist with post-hoc evaluations of weather-related signal timing plans.

Step 6. Monitor and Maintain

After implementation, weather-responsive timing plans may require ongoing monitoring and maintenance. Districts may alter timing plans in response to normal change in travel conditions. Weather-responsive timing plans may also need to be modified based on these new travel demands. Collecting periodic (at least annual) volume data at a mid-block location on each arterial or subsystem is essential when determining if shifts in traffic characteristics occurred or if further investigation is necessary. A good maintenance management system can help an agency identify issues beyond the signal controller, including communication and detection issues, which are often significant contributors to poor operations.

GUIDELINES

This part of the guidelines provides guidelines for determining (1) impacts of weather on intersection-related traffic operations, and (2) potential signal timing strategies to be used at signalized intersections during inclement weather. The information provided is based on established practices and techniques that have been shown to provide safe and efficient signal operation.

Weather-Related Operations Impacts

The following provides general guidance related to using different signal timing strategies during inclement weather events.

Vehicular Travel Speeds

Freeway and arterial travel speeds can be significantly impacted by weather events, particularly events that yield precipitation (16). Table 22 summarizes the effects that various weather conditions can have on vehicular travel speeds.

Table 22. Weather-Related Reductions in Free Flow Speeds.

Roadway Surface Condition	Reduction in Free-Flow Speed (%)	
	Arterial (2)	Freeway (17)
Dry	0%	0%
Wet	6%	0%
Wet and Snowing	11%	13%
Wet and Slushy	18%	22%
Slushy in Wheel Path	18%	30%
Snowy and Sticking	20%	35%
Snowing and Packed	No Data Available	42%

Saturation Flow Rates

Studies have shown that saturation flow rates are inversely proportional to the severity of weather events. Two studies in Alaska reported significantly reduced saturation flow rates (19 percent and 12 percent reductions) during winter weather conditions (18, 19). Similarly, another study with data from Minnesota reported that saturation flow rates decreased from 1800 vehicles per lane to 1600 vehicles per lane (an 11 percent reduction) during severe snowfall events with resultant accumulation (20).

While rain events can affect saturation flow rate, the magnitude of reduction is lower than for winter weather events. In Alabama, researchers reported that saturation flow rates dropped an average of 4.7 percent in rainy conditions (21). Researchers in Poland found that saturation flow rates decreased between 8.5 percent and 12.3 percent during long, all-day rainfall events;

3.6 percent during short rainfall events; 10 percent during snowfall events; and 11.4 percent with the presence of fog (22). Table 23 provides a summary of reduced saturation flow rates for various weather events in Utah (2) and New England (23).

Table 23. Weather-Related Reductions in Saturation Flow Rates.

Roadway Surface Condition	Reduction in Saturation Flow Rate (%)	
	Utah (16)	New England (23)
Dry	0%	0%
Wet	6%	2%–3%
Wet and Snowing	11%	4%–7%
Wet and Slushy	18%	7%–15%
Slushy in Wheel Path	18%	21%
Snowy and Sticking	20%	16%

Start-Up Lost Times

While weather is often perceived to impact start-up lost time, research has found that, except for the most severe conditions, weather does not appear to have a significant effect on start-up lost time at signalized intersections. For severe weather conditions, reductions in start-up lost time were found to be most significant during wet snow conditions where accumulations on pavement surfaces occurred. The following list provides an indication of the varying degree to which wet snow conditions affect start-up lost time:

- In Burlington, Vermont, researchers studied the effects of five different weather conditions on start-up lost time. No significant differences in start-up lost time were observed during any weather conditions studied, except for when the pavement surface conditions were classified as snowy and sticky. Under these conditions, start-up lost time increased from 2.20 seconds to 3.04 seconds (9).
- In Salt Lake City, Utah, only minimal increases in start-up lost time were observed during rain events (i.e., from 2.0 seconds to 2.1 seconds); however, start-up lost times increased from 2.0 seconds to 2.5 seconds when accumulations of snow were present (16).
- In Minnesota, start-up lost time increased from 2 seconds to 3 seconds during severe snow events. However, the roadway where the study was performed was well-maintained and that traction was not an issue, as was first anticipated. On less well-maintained roadways in the area, traction was more problematic, and start-up lost times were greater (20).

Pedestrian Walking Speeds

Research shows that pedestrian walking speeds increase during inclement weather (24). In one study, the average walking speed of younger pedestrians (under 65 years) increased from

4.82 feet per second to 5.24 feet per second (a 9 percent increase). The average speed of older pedestrians (over 65 years) in the study also increased, from 4.03 feet per second to 4.37 feet per second (an 8 percent increase) (10). These rates are well above the design walking speed of 3.5 feet per second specified in the *Manual on Uniform Traffic Control Devices* (25).

Signal Timing Strategies

The following provides general guidelines for using different signal timing strategies during inclement weather events.

Vehicular Red Clearance Intervals

During weather events, the amount of additional time needed for individual clearance intervals depends on a number of factors, including the intersection geometry, approach grades, and approach speeds. Generally, no more than 1 to 2 seconds of additional red clearance time should be added for weather incidents. Practitioners should consider additional red clearance time at the following locations:

- Intersection approaches that have a documented increase in right-angle and red-light-running collisions during inclement weather.
- Intersection approaches located at the bottom of a severe downgrade.
- Minor street approaches where plowing operations are considered to be a low priority.
- Remote or isolated intersections that are difficult to reach during inclement weather.

Some controller features allow practitioners to extend the red interval dynamically until the intersection is clear. Specific logic available in some controller firmware is used to extend the red interval as long as a vehicle is located within a designated detection zone.

Increase Minimum Green Times

The minimum green parameter represents the least amount of time that a green signal indication will be displayed for a phase. Minimum green should be set to meet driver expectations, but its duration may also be based on considerations of queue length or pedestrian timing. High-speed rural locations, especially those with high truck volumes, may benefit from longer times than those at typical urban intersections. During inclement weather, vehicle may require longer start-up times due to loss of friction, and/or increased driver caution.

Table 24 shows suggested minimum green values that may be used during severe weather conditions.

Table 24. Suggested Minimum Green Values to Satisfy Driver Expectancy.

Phase Type	Facility Type	Minimum Green (Seconds)	
		Normal Condition	Severe Weather Conditions
Through	Major Arterial (>40 mph)	10 to 15	15 to 20
	Major Arterial (\leq 40 mph)	7 to 15	10 to 15
	Minor Arterial	4 to 10	6 to 10
	Collectors	2 to 10	5 to 10
Left Turn	Any	2 to 5	5 to 10

Caution should be used when increasing the minimum green times due to severe weather conditions. Minimum greens that are too long may result in increased delay and excessive queues at an intersection. This strategy is recommended only for those locations where loss of pavement friction can be expected for long durations.

Phase Recalls

The recall parameter is one that can be used to guarantee that cross-street or minor phases receive service during inclement weather conditions. Recalls are used to automatically call specified phases regardless of the presence of any detector-actuated calls. Four types of recalls are common with most traffic signal controllers—minimum recall (also known as vehicle recall), maximum recall, soft recall, and pedestrian recall—although minimum recall and maximum recall are the two used most commonly with weather responsive traffic operations. Descriptions are recalls are as follows:

- *Minimum Recall:* The minimum recall parameter causes the controller to place a call for vehicle service on a phase in order to serve at least its minimum green duration.
- *Maximum Recall:* The maximum recall parameter causes the controller to place a continuous call for vehicle service on a phase in order to run its maximum green duration every cycle.
- *Soft Recall:* The soft recall parameter causes the controller to place a call for vehicle service on a phase in the absence of a serviceable conflicting call.
- *Pedestrian Recall:* The pedestrian recall parameter causes the controller to place a continuous call for pedestrian service on a phase, resulting in the controller timing its walk and FDW intervals every cycle.

For weather responsive operations, this strategy is used most often when weather conditions affect detection. For example, in some locations where video detection has been used, ice and fog can impede operations of the detectors. Using the recall functions during these conditions forces the controller to service selected phases every cycle. Generally, agencies will use a minimum recall on cross-street phases guaranteeing that these approaches will receive service

and maximum recall of main-street minor phases (such as protected left turns) to ensure the maximum degree of safety for these movements.

Weather-Responsive Coordination Plans

Four controller parameters are usually used to define a coordination timing plan: cycle length, phase split durations, offsets, and phase sequences. Cycle lengths, in combination with splits and offsets, establish relationships between intersections. The cycle length is generally selected to address operations at the most critical (or highest volume) intersection. Phase splits allocate the cycle length between the main street (or coordinated phases) and the cross-streets, while offsets are chosen based on the actual or desired travel speed between intersections. When taken together (along with pedestrian considerations), these three parameters define how intersections should operate to progress traffic through the corridor. The percent arrival on green, the ratio of arrivals on green to arrival on reds, the number of stops per mile, and the travel time (or average speed) define the quality of progression that a timing plan provides.

With weather responsive timing plans, the design objectives change from maximizing travel speeds to matching the travel speeds that drivers feel are safe for the prevailing conditions. If the weather conditions do not have a significant impact on travel speeds, then implementing a weather responsive timing plan may only make travel conditions worse in the corridor; however, if the weather is severe enough to impact travel speed, then the corridor may benefit from having a special timing plan designed to accommodate slower travel speeds. The following guidance is provided for developing weather responsive timing plans to implement in a corridor:

- To the extent possible, maintain the same cycle lengths and phase splits as used in normal conditions. Unless the weather event is unusually severe (like a hurricane or major icy storm or blizzard), traffic demands do not change significantly during most weather events; the same TOD cycle lengths and split plans can be used as the bases for developing new weather responsive timing plans.
- Compute new offsets for each timing plan to accommodate reductions in speeds observed (or anticipated) during the weather event. Observed (or predicted) travel speeds during the weather events should be 10 to 15 mph slower than the normal travel speeds observed in the corridor. If travel speeds are not 10 to 15 mph slower during severe weather conditions, then it may not be worthwhile (beneficial) to implement weather responsive timing plans.
- Once the new offsets have been implemented and they do not produce good progression, consider adjusting the phase sequencing at each intersection so as to maximize the progression band and throughput through the corridor.
- During weather events, monitor queues and delays at each intersection to ensure that above changes do not result in spillbacks from turn bays into the main lanes and excessive delays on cross-street approaches.

Establishing Thresholds for Activating and Deactivating Weather Responsive Timing Plans

In selecting thresholds for activating and deactivating weather responsive timing planes, the engineer should consider the time required to transition to and from the weather responsive timing plan. Studies have shown that, depending on the transition methodology used by the controller and how much the offset reference point needs to shift, transitioning to a new timing plan can take between one and five cycles before coordination can be reestablished. During this transition, the split durations (and the cycle lengths) during the transition period will be different from those programmed in either the normal timing plan or the weather responsive timing plan. This can be very disruptive to traffic operations on the roadway. Because of this, the *Traffic Signal Timing Manual (15)* provides the following recommendations related to changing timing plans patterns:

- Use robust timing plans that can cover a wide range of operating conditions and avoid trying to match timing patterns too closely, as this may prevent the controller from ever achieving coordination.
- Remain in a coordination plan for at least 30 minutes before transitioning into another plan.
- Avoid changing patterns during congested conditions with the signals need to operate at their maximum efficiency, unless weather conditions are severe enough to cause major disruption in travel speeds in the corridor.

With this guidance in mind, the following recommendations are provided for establishing thresholds for activating and deactivating weather responsive timing plans:

- To activate a weather responsive timing plan, the thresholds need to be set to represent the worse conditions for which you want the system to activate. The research team recommends the following pavement condition values for activating weather responsive timing plans:
 - Consider activating the weather responsive timing plans only when the pavement surface state or grip value is assessed to be POOR, ICE, SNOW, or STANDING WATER.
 - Do not activate timing plans when the service conditions are classified as WET. The WET status indication can represent wide range of surface conditions—from moderate rain showers to heavy storms. Previous research has shown that travel speeds are not significantly impacted by slight to moderate rain conditions. The engineer may want to use an additional indicator (such as numeric values for friction, a water depth indicator, or pavement surface temperature) to ensure that the weather responsive timing plans are only used during significant weather conditions.
- Consider implementing a persistency check with the threshold to ensure that the pavement conditions have truly deteriorated to a level where a weather responsive traffic

signal timing plan would be beneficial. For example, require that the measured condition persist for at least 5 minutes before making the decision to implement the weather responsive timing plan.

- Once the weather responsive timing plan has been implemented, do not let the system implement another control strategy, including deactivation, for at least 30 minutes.
- When deactivating, use a parameter that represents a condition at least one level higher than the activation threshold. For example, if the system is set to activate when the friction code is 0.3, use a deactivation threshold of at least 0.5 or FAIR, WET, or DAMP to deactivate the system.
- Consider implementing a persistency change to ensure that weather conditions last for a specified duration before activating or deactivating a weather responsive timing plan.
- Use smoothed or displayed condition parameters instead of instantaneous or measured conditions. This will help prevent the system from activating and deactivating too quickly based on minor fluctuations in weather conditions.

REFERENCES

1. *Road Weather Management Program*. US Department of Transportation, Federal Highway Administration. <http://www.ops.fhwa.dot.gov/weather/>. Accessed November 2016.
2. Federal Highway Administration Road Weather Management: *Siting Guidelines for Road Weather Information System (RWIS) Environmental Sensor Stations (ESS)*. Publication No. FHWA-HOP-05-025, EDL No. 14109.
3. J. K. Garrett, B. Boyce, D. Krechmer and W. Perez: *Implementation and Evaluation of RWIS ESS Siting Guide*. Mixon/Hill, Inc. and Cambridge Systematics. Report No. FHWA-JPO9-013. November, 2008.
4. Task Force on Evacuation, Transportation and Logistics. Final Report to the Governor, Texas. February 14, 2006. Available at <http://gov.texas.gov/files/press-office/EvacuationTaskForceReport.pdf>.
5. Ballard, Andrew J. and Borchardt, Darrel W. 2006. *Recommended Practices for Hurricane Evacuation Traffic Operations*. FHWA/TX-06/0-4962-P2. Austin, Texas: Texas Department of Transportation, Research and Technology Implementation Office.
6. Chen, Ming, Chen L., Miller-Hooks, E. *Traffic Signal Timing for Urban Evacuations*. *Journal of Urban Planning and Development*, March 2007. American Society of Civil Engineers.
7. *Hurricane Rita: Lessons Learned from Houston Great Evacuation*. Website Accessed 10/24/2015. http://www.terraily.com/reports/Lessons_From_Hurricane_Rita_Not_Practiced_During_Ike_999.html.
8. Sisiopiku, Virginia P. *Regional Traffic Simulation for Emergency Preparedness*. University Transportation Center for Alabama. April 30, 2004.
9. Jahangiri, Arash, Afandizadeh, S., Kalantari N. “The Optimization of Traffic Signal Timing for Emergency Evacuation using Simulated Annealing Algorithm.” *Transport* Volume 26(2), Pages 133–140, 2011.
10. Gu, Yahong. *Integrating a Regional Planning Model (TRANSIMS) With an Operational Model (CORSIM)*. Master’s Thesis Virginia Polytechnic Institute and State University, January 2004.
11. Chen, Ming. *Traffic Signal Timing for Urban Evacuations*. Thesis, University of Maryland, College Park, 2005.
12. Liu, Yue, Chang, G., Liu, Y., and Lai, X. “Corridor-Based Emergency Evacuation System for Washington, D.C.” TRR No. 2041, *Transportation Research Board of the National Academy of Sciences*, Washington, D.C. 2008, pp 58–67.
13. Parr, Scott and Kaiser, Evangelos. 2010. *Critical Intersection Signal Optimization during Urban Evacuation Utilizing Dynamic Programming*. Paper presented at National Evacuation Conference, New Orleans, LA.

14. U.S. Department of Transportation. 2009. *Traffic Signal Timing Manual-Chapter 9: Advanced Signal Timing Topics* Washington, D.C. Federal Highway Administration: Office of Operations, U.S. Department of Transportation.
<http://ops.fhwa.dot.gov/publications/fhwahop08024/chapter9.htm>.
15. Urbanik, T., A. Tanaka, B. Lozner, E. Linstrom, K. Lee, S. Quayle, S. Beard, S. Tsoi, P. Ryus, D. Gettman, S. Sunkari, K. Balke, and D. Bullock. *Signal Timing Manual. Second Edition*. NCHRP Report 812. Transportation Research Board, National Cooperative Highway Research Program. Washington, D.C. 2015. pp 11-2–11-6.
16. Perrin, H. J., P. T. Martin, and B. G. Hansen. “Modifying Signal Timing during Inclement Weather.” In *Transportation Research Record: Journal of the Transportation Research Board*, No. 1748, Transportation Research Board, National Research Council, Washington, D.C., 2001, pp. 66–71.
17. McBride, J. C., W. J. Kennedy, J. H. Thuet, M. C. Belangie, R. M. Stewart, C. C. Sy, and F. R. McConkie. *Economic Impact of Highway Snow and Ice Control*. Report FHWA-RD- 77-95, Federal Highway Administration, United States Department of Transportation, 1977.
18. *Anchorage Signal System Upgrade—Final Report*. Bernardin Lochmueller & Associates, Inc., Anchorage, Alaska, 1995.
19. Botha, J., and T. Kruse. “Flow Rates at Signalized Intersections under Cold Winter Conditions.” *Journal of Transportation Engineering*, Vol. 118, No. 3, 1992, pp. 439–450.
20. Maki, P. J. *Adverse Weather Traffic Signal Timing*. Proc., 69th Annual Meeting of the Institute of Transportation Engineers, Las Vegas, Nevada, 1999.
21. Sullivan, A. J., V. P. Sisiopiku, and S. Reddy-Surhabi. *Impacts of Signal System Timings on Rain Related Congestion*. Report FHWA/CA/OR, University Transportation Center for Alabama, 2010.
22. Chodur, J., K. Ostrowski, and M. Tracz. *Impact of Saturation Flow Changes on Performance of Traffic Lanes at Signalised Intersections*. Presented at the 6th International Symposium on Highway Capacity, Stockholm, Sweden, 2011.
23. Agbolosu-Amison, S. J., A. W. Sadek, and W. El Dessouki. “Inclement Weather and Traffic Flow at Signalized Intersections: Case Study from Northern New England.” In *Transportation Research Record: Journal of the Transportation Research Board*, No. 1867. Transportation Research Board of the National Academies, Washington, D.C., 2004, pp. 163–171.
24. Knoblauch, R., M. Pietrucha, and M. Nitzburg. “Field Studies of Pedestrian Walking Speed and Start-Up Time.” In *Transportation Research Record 1538*. Transportation Research Board, National Research Council, Washington, D.C., 1996, pp. 27–38.
25. *Manual on Uniform Traffic Control Devices for Streets and Highways*, 2009 Edition. United States Department of Transportation, Federal Highway Administration, Washington, D.C., 2009.

**APPENDIX A. WEATHER RESPONSIVE TIMING PLANS FOR US 87 IN
DUMAS, TX**

US 87/1st Street

	Phase								Cycle Length	Offset	Phasing
	1	2	3	4	5	6	7	8			
Min Gr.	7	7	7	7	7	7	7	7	82	0	
Yellow	4	4	4	4	4	4	4	4			
All Red	1.5	1.5	1.5	1.5	1.5	1.5	1.5	1.5			
Walk											
FDW											
30 mph	13	30	13	26	14	29	13	26	82	0	1 Leading
25 mph	13	30	13	26	14	29	13	26	82	0	1 Leading
20 mph	13	30	13	26	14	29	13	26	82	0	1 Leading

US 87/4th Street

	Phase								Cycle Length	Offset	Phasing
	1	2	3	4	5	6	7	8			
Min Gr.		7		7		7			82	72	
Yellow		3		3		3					
All Red		1		2		2					
Walk											
FDW											
30 mph		60		22		60			82	72	
25 mph		60		22		60			82	32	
20 mph		60		22		60			82	34	

US 87/5th Street

	Phase								Cycle Length	Offset	Phasing
	1	2	3	4	5	6	7	8			
Min Gr.		7		7		7			82	34	
Yellow		3		3		3					
All Red		1		2		2					
Walk											
FDW											
30 mph		60		22		60			82	34	
25 mph		60		22		60			82	32	
20 mph		60		22		60			82	34	

US 87/6th Street

	Phase								Cycle Length	Offset	Phasing
	1	2	3	4	5	6	7	8			
Min Gr.		7		7		7					
Yellow		3		3		3					
All Red		1		2		2					
Walk											
FDW											
30 mph		60		22		60			82	35	
25 mph		60		22		60			82	32	
20 mph		60		22		60			82	73	

US 87/7th Street

	Phase								Cycle Length	Offset	Phasing
	1	2	3	4	5	6	7	8			
Min Gr.		7		7		7					
Yellow		3		3		3					
All Red		1		2		2					
Walk											
FDW											
30 mph		60		22		60			82	35	
25 mph		60		22		60			82	32	
20 mph		60		22		60			82	73	

US 87/8th Street

	Phase								Cycle Length	Offset	Phasing
	1	2	3	4	5	6	7	8			
Min Gr.		7		7		7					
Yellow		3		3		3					
All Red		1		2		2					
Walk											
FDW											
30 mph		60		22		60			82	34	
25 mph		60		22		60			82	75	
20 mph		60		22		60			82	77	

**APPENDIX B. WEATHER RESPONSIVE TIMING PLANS FOR SH 1747
IN BURLESON, TX**

SH 174/Hillery

	Weather Responsive Plan	Phase								Cycle Length	Offset	Phasing	Existing Alternate Sequence
		1	2	3	4	5	6	7	8				
Min Gr.		5	10	5	5	5	10						
Yellow		4	4	4	4	4	4						
All Red		2	2	3	3	2	2						
Walk				7			7						
FDW				21			12						
AM Peak	3/1/1	16	62	22	20	16	62			120	51	1 & 4 Leading	6
Midday	3/2/1	16	64	20	20	16	64			120	114	5 & 3 Leading	4
PM Peak	3/3/1	16	68	18	18	16	68			120	9	1, 5, & 3 Leading	4
Sat. Peak	4/1/1	18	60	22	20	18	60			120	0	5 & 3 Leading	4

SH 174/Renfro

	Weather Responsive Plan	Phase								Cycle Length	Offset	Phasing	Existing Alternate Sequence
		1	2	3	4	5	6	7	8				
Min Gr.		5	10	5	5	5	10	5	5				
Yellow		4	4	4	4	4	4	4	4				
All Red		2	2	3	3	2	2	3	3				
Walk			7		7		7		7				
FDW			10		22		12		19				
AM Peak	3/1/1	16	50	20	34	16	50	20	34	120	119	5, 3, & 7 Leading	1
Midday	3/2/1	24	40	20	36	16	48	30	26	120	66	5, 3, & 7 Leading	1
PM Peak	3/3/1	20	56	14	30	18	58	20	24	120	67	5, 3, & 7 Leading	1
Sat. Peak	4/1/1	24	40	18	38	16	48	28	28	120	90	1, 5, 3, & 7 Leading	1

SH 174/Tarrant/Elison

	Weather Responsive Plan	Phase								Cycle Length	Offset	Phasing	Existing Alternate Sequence
		1	2	3	4	5	6	7	8				
Min Gr.		5	10		5	5	10		5				
Yellow		4	4		4	4	4		4				
All Red		2	2		3	2	2		3				
Walk			7				7		7				
FDW			12				12		15				
AM Peak	3/1/1	16	72		32	16	72		32	120	6	1 Leading	0
Midday	3/2/1	20	66		34	20	66		34	120	73	1 & 5 Leading	0
PM Peak	3/3/1	16	74		30	16	74		30	120	71	5 Leading	1
Sat. Peak	4/1/1	18	72		30	18	72		30	120	41	1 Leading	0

SH 174/Newton

	Weather Responsive Plan	Phase								Cycle Length	Offset	Phasing	Existing Alternate Sequence
		1	2	3	4	5	6	7	8				
Min Gr.		5	10	5	5	5	10						
Yellow		4.5	5	4	4	4.5	4.5						
All Red		2	2	3	3	2	2						
Walk			7	7			7						
FDW			12	24			12						
AM Peak	3/1/1	16	54	25	25	16	54			120	114	1 & 4 Leading	6
Midday	3/2/1	20	50	25	25	16	54			120	69	5 & 3 Leading	4
PM Peak	3/3/1	16	64	20	20	16	64			120	70	1 & 3 Leading	4
Sat. Peak	4/1/1	18	54	24	24	16	56			120	44	5 & 3 Leading	4

SH 174/Summercrest/Gardens

	Weather Responsive Plan	Phase								Cycle Length	Offset	Phasing	Existing Alternate Sequence
		1	2	3	4	5	6	7	8				
Min Gr.		5	10	5	5	5	10						
Yellow		4.5	5	4	4	4.5	4.5						
All Red		2	2	3	3	2	2						
Walk			7		7		7						
FDW			10		26		10						
AM Peak	3/1/1	18	50	26	26	16	52			120	60	5 & 3 Leading	1
Midday	3/2/1	20	54	22	24	18	56			120	1	5 & 3 Leading	1
PM Peak	3/3/1	18	58	22	22	18	58			120	119	1 & 3 Leading	4
Sat. Peak	4/1/1	22	52	22	24	18	56			120	98	5 & 3 Leading	1

SH 174/McNairn/Hidden Creek

	Weather Responsive Plan	Phase								Cycle Length	Offset	Phasing	Existing Alternate Sequence
		1	2	3	4	5	6	7	8				
Min Gr.		5	10	5	5	5	10						
Yellow		5	5	4	4	5	5						
All Red		2	2	3	3	2	2						
Walk			7	7	7		7						
FDW			14	30	30		14						
AM Peak	3/1/1	16	58	18	28	20	54			120	53	1 & 3 Leading	4
Midday	3/2/1	16	58	16	30	30	44			120	119	1 & 3 Leading	4
PM Peak	3/3/1	14	64	16	26	32	46			120	55	1, 5, & 3 Leading	1
Sat. Peak	4/1/1	16	58	16	30	30	44			120	88	1 & 3 Leading	4

SH 174/Chamber

	Weather Responsive Plan	Phase								Cycle Length	Offset	Phasing	Existing Alternate Sequence
		1	2	3	4	5	6	7	8				
Min Gr.		5	10		5	5	10		5				
Yellow		5	5		4	5	5		4				
All Red		2	2		2	2	2		2				
Walk					7								
FDW					27								
AM Peak	3/1/1	16	74		30	16	74		30	120	119	1 & 5 Leading	1
Midday	3/2/1	18	72		30	18	72		30	120	58	5 Leading	1
PM Peak	3/3/1	16	74		30	18	72		30	120	66	5 Leading	0
Sat. Peak	4/1/1	18	70		32	18	70		32	120	41	1 & 5 Leading	1

SH 174/Elk/Arnold

	Weather Responsive Plan	Phase								Cycle Length	Offset	Phasing	Existing Alternate Sequence
		1	2	3	4	5	6	7	8				
Min Gr.		5	10	5	5	5	10						
Yellow		5	5	4	4	5	5						
All Red		2	2	3	3	2	2						
Walk					7		7						
FDW					28		11						
AM Peak	3/1/1	20	52	28	20	16	56			120	114	1 & 4 Leading	1
Midday	3/2/1	18	58	26	18	16	60			120	62	1 & 4 Leading	6
PM Peak	3/3/1	16	62	24	18	16	62			120	60	1, 5, & 4 Leading	6
Sat. Peak	4/1/1	16	60	24	20	16	60			120	43	1 & 4 Leading	6

SH 174/John Jones (FM 731)

	Weather Responsive Plan	Phase								Cycle Length	Offset	Phasing	Existing Alternate Sequence
		1	2	3	4	5	6	7	8				
Min Gr.		5	10	5	5	5	10	5	5				
Yellow		5	5	5	5	5	5	5	5				
All Red		2	2	2	2	2	2	2	2				
Walk			7				7		7				
FDW			30				30		35				
AM Peak	3/1/1	24	46	30	20	20	50	20	30	120	106	5 & 7 Leading	0
Midday	3/2/1	22	50	26	22	26	46	22	26	120	117	1 & 7 Leading	5
PM Peak	3/3/1	22	50	28	20	22	50	20	28	120	2	5 & 7 Leading	5
Sat. Peak	4/1/1	24	48	28	20	24	48	20	28	120	92	1 & 7 Leading	15

SH 174/Hulen

	Weather Responsive Plan	Phase								Cycle Length	Offset	Phasing	Existing Alternate Sequence
		1	2	3	4	5	6	7	8				
Min Gr.		5	10		5	5	10						
Yellow		5	5		5	5	5						
All Red		2	2		2	2	2						
Walk													
FDW													
AM Peak	3/1/1	27	57		37	27	57			121	Actuated	5 Leading	1
Midday	3/2/1	27	57		36	27	57			120	Actuated	5 Leading	1
PM Peak	3/3/1	14	76		30	16	74			120	Actuated	1 Leading	4
Sat. Peak	4/1/1	27	57		37	27	57			121	Actuated	1 & 5 Leading	0

**APPENDIX C. WEATHER RESPONSIVE TIMING PLANS FOR NASA
ROAD 1 IN NASSAU BAY, TX**

NASA Road 1/Nassau Bay Drive

	Phase								Cycle Length	Offset	Phasing
	1	2	3	4	5	6	7	8			
AM Peak	14	76	14	16	16	74	14	16	120	36	5, 3 leading
Midday	13	61	13	18	16	58	18	13	105	11	1, 3 leading
PM Peak	14	79	14	28	19	74	28	14	135	12	1, 3 leading
Sat. Peak	14	45	13	18	14	45	13	18	90	41	1, 5, 3 leading

NASA Road 1/Point Lookout Drive

	Phase								Cycle Length	Offset	Phasing
	1	2	3	4	5	6	7	8			
AM Peak	15	74	16	15	18	71			120	90	1, 4 leading
Midday	15	54	23	13	17	52			105	61	1, 4 leading
PM Peak	16	81	13	25	18	79			135	18	5, 4 leading
Sat. Peak	14	45	18	13	17	42			90	80	5, 4 leading

NASA Road 1/Saturn Lane

	Phase								Cycle Length	Offset	Phasing
	1	2	3	4	5	6	7	8			
AM Peak	30	50	17	15	15	73			120	103	5, 4 leading
Midday	25	44	18	18	15	54			105	62	5 leading
PM Peak	18	71	14	32	18	71			135	82	1 leading
Sat. Peak	16	40	16	18	15	41			90	30	1 leading

NASA Road 1/Upper Bay Road

	Phase								Cycle Length	Offset	Phasing
	1	2	3	4	5	6	7	8			
AM Peak	26	64	18	12	18	72			120	98	5, 4 Leading
Midday	14	59	18	14	18	55			105	3	1, 4 Leading
PM Peak	14	78	29	14	22	70			135	80	5, 4 Leading
Sat. Peak	14	45	18	13	17	42			90	30	5, 4 Leading

NASA Road 1/St. Johns Drive

	Phase								Cycle Length	Offset	Phasing
	1	2	3	4	5	6	7	8			
AM Peak		88			18	70		32	120	45	5 lagging
Midday		77			13	59		28	100	1	5 leading
PM Peak		103			18	85		32	135	81	5 leading
Sat. Peak		62			14	48		28	90	76	5 lagging

NASA Road 1/Space Center Boulevard

	Phase								Cycle Length	Offset	Phasing
	1	2	3	4	5	6	7	8			
AM Peak	38	40			14	64	28	14	120	37	1, 8 leading
Midday	28	39			14	53	24	14	105	9	5, 8 leading
PM Peak	38	51			14	75	32	14	135	93	5, 8 leading
Sat. Peak	22	34			15	42	20	24	90	85	5, 8 leading

**APPENDIX D. WEATHER RESPONSIVE TIMING TRAINING
MATERIALS**



GUIDELINES FOR DEPLOYING WEATHER RESPONSIVE OPERATIONS IN TXDOT TRAFFIC SIGNALS

TxDOT 0-6861: Improving Safety and Efficiency of
Signalized Intersections During Inclement Weather
by

Texas A&M Transportation Institute
Kevin N. Balke, Ph.D., PE., PMP



Weather as Contributing Factor

Fatalities on Rural Texas Roads

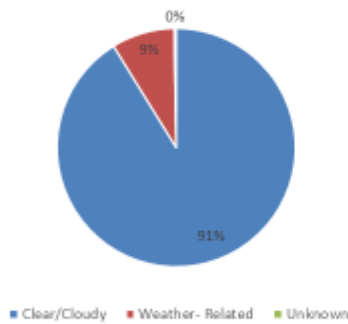

Crashes on Rural Texas Roads

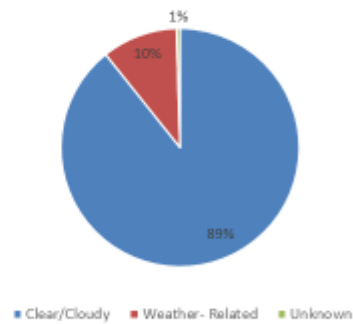

Source: Texas Motor Vehicle Crash Statistics - 2014





Poor Road Surface Conditions

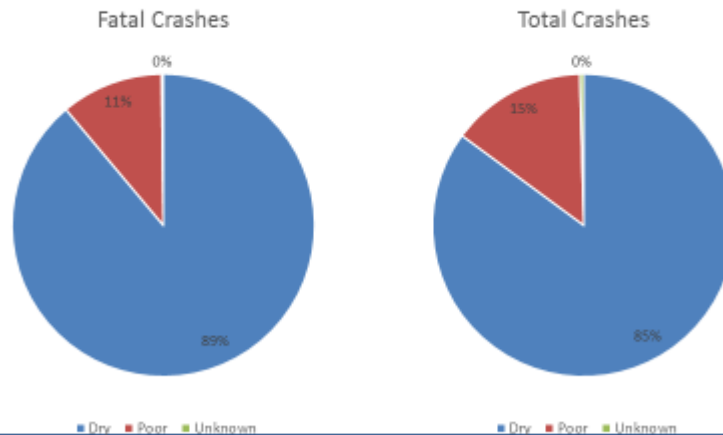

Project Goals and Objectives

- Quantify impacts of weather on traffic signal operations
- Identify appropriate weather responsive traffic management (WRTM) strategies for signals
- Establish criteria and architecture for deploying WRTM
- Update *Traffic Signal Operations Handbook*
- Develop and pilot test training course

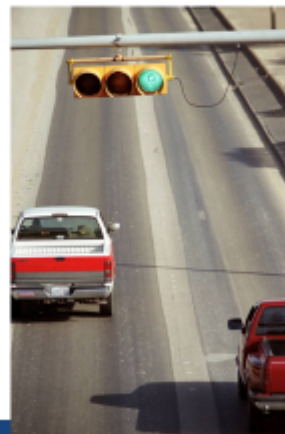



TxDOT 0-6861: Improving Safety and Efficiency of Signalized Intersections During Inclement Weather

WEATHER IN TEXAS



Regions in Texas

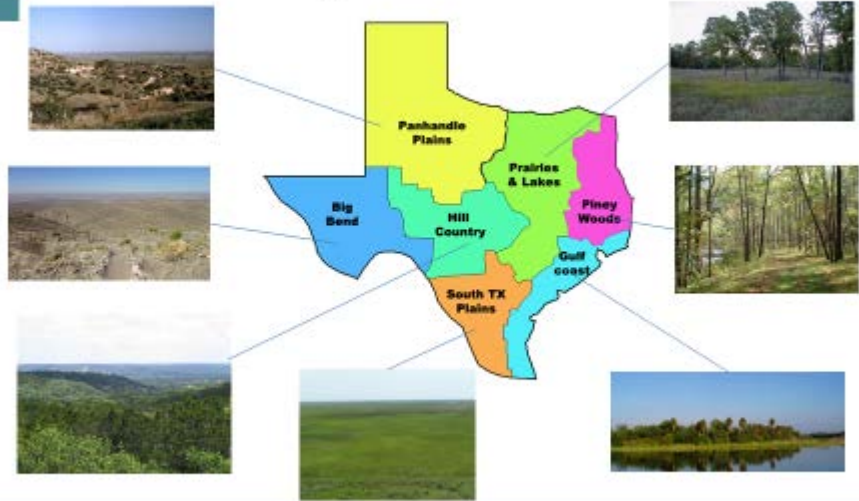



“If you don’t like the weather in Texas, wait a few hours – it’ll change!”

Average Annual Precipitation

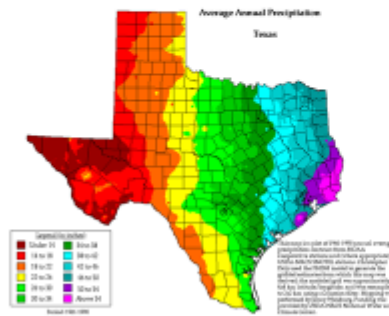

Mean Annual Temperature

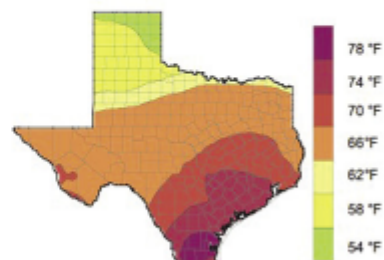

Recent Texas Weather Events





Monthly Avg. Temperature (°F)

City	Monthly Average Temperature (2010-2014)											
	Jan	Feb	Mar	Apr	May	Jun	Jul	Aug	Sep	Oct	Nov	Dec
Abilene	45	47	58	67	74	83	85	86	77	67	56	47
Amarillo	38	38	50	59	68	79	81	81	72	59	47	40
Atlanta	43	47	56	65	72	83	83	86	79	65	54	47
Austin	49	52	61	70	76	83	85	86	81	70	59	52
Beaumont	52	54	61	70	76	83	83	85	81	70	59	54
Brownwood	45	49	58	68	74	85	86	88	79	68	56	49
Bryan	-	-	-	-	-	-	-	-	-	-	-	-
Childress	41	41	54	63	72	83	85	85	76	65	52	43
Corpus Christi	58	59	67	76	79	85	86	86	83	76	67	61
Dallas	47	49	59	68	76	85	88	90	81	70	58	50
El Paso	45	47	59	68	74	86	83	85	76	68	54	47
Fort Worth	47	49	58	67	74	85	86	88	81	68	58	49
Houston	52	56	63	70	77	85	85	86	81	72	61	58
Laredo	58	61	70	79	83	88	88	92	85	77	67	59
Lubbock	41	43	54	63	72	81	81	81	74	63	50	43
Lufkin	49	50	59	68	74	83	83	86	79	68	58	50
Odessa	45	49	59	68	74	85	83	85	76	67	54	47
Paris	43	45	56	65	74	85	86	88	79	67	54	45
Pharr	-	-	-	-	-	-	-	-	-	-	-	-
San Antonio	50	52	63	70	77	85	86	88	81	70	59	52
Tyler	47	50	59	68	76	83	85	86	79	68	56	50
Waco	47	50	58	68	76	85	86	88	81	68	58	50
Wichita Falls	43	45	56	65	74	85	86	86	77	67	52	43
Yoakum	52	56	63	70	77	83	85	86	81	72	61	56



Avg. Min Temperature (°F)

City	Monthly Average Minimum Temperature (2010-2014)											
	Jan	Feb	Mar	Apr	May	Jun	Jul	Aug	Sep	Oct	Nov	Dec
Abilene	34	34	45	54	61	72	74	74	65	54	43	36
Amarillo	-	-	-	-	-	-	-	-	-	-	-	-
Atlanta	36	36	43	52	61	70	72	72	65	52	41	36
Austin	38	41	49	58	65	72	74	74	68	58	47	41
Beaumont	41	45	52	59	67	74	76	76	70	59	49	45
Brownwood	34	36	41	52	61	70	72	74	65	54	40	36
Bryan	-	-	-	-	-	-	-	-	-	-	-	-
Childress	-	-	-	-	-	-	-	-	-	-	-	-
Corpus Christi	49	50	58	67	72	77	77	77	76	67	56	50
Dallas	38	40	49	58	65	76	77	79	70	58	47	40
El Paso	34	36	43	52	58	72	72	70	61	54	40	34
Fort Worth	36	38	47	56	63	74	76	77	68	56	45	40
Houston	43	47	54	61	68	76	76	77	72	61	50	47
Laredo	47	50	58	67	70	77	77	79	74	67	56	49
Lubbock	-	-	-	-	-	-	-	-	-	-	-	-
Lufkin	38	40	47	56	63	72	74	74	67	54	43	40
Odessa	34	36	45	54	61	72	72	72	65	54	41	36
Paris	36	36	45	54	63	74	76	77	68	56	43	38
Pharr	-	-	-	-	-	-	-	-	-	-	-	-
San Antonio	40	41	49	58	65	74	74	76	68	58	47	41
Tyler	36	40	47	56	63	74	74	76	68	56	45	40
Waco	36	38	47	56	63	74	76	77	68	56	45	40
Wichita Falls	34	36	41	52	61	72	74	74	65	52	40	34
Yoakum	41	45	50	59	67	74	74	74	70	59	50	45





Avg. Max Temperature (°F)

City	Monthly Average Maximum Temperature (2010-2014)											
	Jan	Feb	Mar	Apr	May	Jun	Jul	Aug	Sep	Oct	Nov	Dec
Abilene	56	59	72	81	88	95	97	101	90	79	68	58
Amarillo	52	50	67	76	83	94	92	94	86	76	63	52
Atlanta	56	58	68	79	85	94	95	99	92	79	67	58
Austin	61	65	74	81	86	95	95	99	92	83	70	63
Beaumont	61	63	72	79	86	92	92	95	90	83	72	65
Brownwood	61	61	74	83	88	97	99	103	94	83	70	61
Bryan	-	-	-	-	-	-	-	-	-	-	-	-
Childress	54	54	68	77	86	95	95	99	88	79	65	54
Corpus Christi	67	68	76	83	86	94	94	95	92	86	76	70
Dallas	58	59	70	79	86	95	97	101	92	81	68	59
El Paso	59	61	74	81	88	101	95	97	88	83	68	59
Fort Worth	58	58	70	79	85	95	97	101	92	81	68	58
Houston	63	65	74	81	86	94	94	95	92	83	72	67
Laredo	68	72	83	90	94	101	99	103	95	90	77	70
Lubbock	56	58	70	79	86	94	92	94	85	77	65	56
Lufkin	61	61	72	79	86	94	94	97	92	81	68	61
Odessa	59	61	74	83	88	97	94	97	86	79	67	58
Paris	54	54	67	76	85	94	97	99	92	79	65	54
Pharr	-	-	-	-	-	-	-	-	-	-	-	-
San Antonio	63	65	76	85	88	95	97	101	92	83	72	65
Tyler	58	59	70	79	86	94	95	97	90	79	67	59
Waco	59	61	70	79	86	94	95	99	92	81	70	61
Wichita Falls	56	56	68	77	86	97	97	101	90	79	67	54
Yoakum	63	65	74	81	86	94	94	97	92	85	72	67



Avg. Total Precipitation (in.)

City	Monthly Average Total Precipitation (2010-2014)											
	Jan	Feb	Mar	Apr	May	Jun	Jul	Aug	Sep	Oct	Nov	Dec
Abilene	1.23	1.30	0.91	1.50	2.41	2.64	2.72	0.99	2.96	1.74	0.71	0.87
Amarillo	0.52	1.07	0.52	0.91	2.17	2.17	2.01	1.74	2.49	0.67	0.75	0.60
Atlanta	2.92	2.76	3.08	3.63	4.06	2.64	2.72	1.58	4.30	3.27	3.15	4.14
Austin	2.37	1.15	1.82	1.50	4.57	1.62	3.43	0.52	5.32	3.67	2.45	1.38
Beaumont	4.14	4.45	3.12	2.41	3.71	4.10	7.68	2.76	4.69	2.37	3.59	3.39
Brownwood	3.00	1.38	1.50	1.26	3.59	2.41	2.76	1.58	2.64	3.15	1.19	1.70
Bryan	3.12	0.99	0.87	1.50	6.07	2.29	3.43	1.26	3.75	4.53	3.12	1.74
Childress	0.52	0.95	0.67	2.01	1.78	3.35	2.17	2.17	1.70	1.38	1.15	0.71
Corpus Christi	2.25	1.78	0.79	1.23	1.78	1.86	2.21	0.75	6.78	1.97	1.54	0.79
Dallas	2.60	1.38	2.25	2.45	3.94	3.08	1.58	2.09	3.55	2.56	1.58	2.64
El Paso	0.20	0.20	0.16	0.32	0.12	0.16	1.66	1.54	3.51	0.44	0.12	0.32
Fort Worth	2.96	1.42	2.25	2.37	3.04	3.12	1.34	1.50	3.31	2.72	1.46	2.13
Houston	3.04	2.68	2.33	2.09	4.14	2.84	6.11	2.29	4.22	2.80	3.08	3.31
Laredo	0.91	0.67	0.63	1.15	2.25	0.75	2.76	0.44	3.51	1.15	0.48	1.30
Lubbock	0.60	0.83	0.83	1.50	1.70	2.09	2.13	1.42	2.52	0.99	0.63	0.56
Lufkin	3.90	3.00	3.63	2.33	3.75	3.55	4.69	1.74	4.49	2.80	3.55	3.27
Odessa	0.56	0.32	0.12	0.36	1.03	0.79	1.38	0.60	2.60	0.60	0.44	0.63
Paris	2.29	2.01	3.71	3.51	5.32	2.64	4.38	0.91	3.00	3.47	2.52	3.15
Pharr	-	-	-	-	-	-	-	-	-	-	-	-
San Antonio	2.01	1.15	0.91	1.30	5.12	1.50	1.62	1.11	4.14	1.78	1.46	0.83
Tyler	2.92	2.96	3.55	2.60	3.27	4.41	3.31	1.46	3.98	4.65	2.64	3.12
Waco	3.51	2.05	3.43	1.93	3.15	3.51	2.60	0.83	4.49	3.47	1.74	1.86
Wichita Falls	0.79	1.26	1.34	2.01	2.09	2.29	2.13	1.78	3.67	2.05	1.19	0.99
Yoakum	3.31	1.78	2.76	1.97	3.82	2.25	4.61	1.23	6.23	1.89	1.62	1.54





Max Precipitation in Day (in.)

City	Extreme Maximum Daily Precipitation Total (2010-2014)											
	Jan	Feb	Mar	Apr	May	Jun	Jul	Aug	Sep	Oct	Nov	Dec
Abilene	0.79	0.83	0.52	0.91	0.95	1.34	1.30	0.67	1.46	1.34	0.52	0.48
Amarillo	0.44	0.56	0.28	0.40	1.15	0.91	1.11	0.87	1.23	0.40	0.56	0.36
Atlanta	0.91	0.99	1.19	1.54	1.50	1.46	1.34	0.99	2.41	1.50	1.19	1.46
Austin	1.54	0.56	1.03	1.03	2.37	0.83	1.86	0.48	2.76	1.93	1.19	0.52
Beaumont	1.89	1.42	1.54	1.11	2.33	1.50	2.72	1.15	1.78	0.99	1.86	1.38
Brownwood	1.70	0.63	0.60	0.75	1.62	1.26	2.17	0.91	1.50	2.41	0.79	1.03
Bryan	1.66	0.40	0.48	0.95	2.64	1.89	2.68	0.71	2.25	2.21	0.95	0.83
Childress	0.44	0.44	0.32	1.26	0.95	1.86	0.99	0.99	0.63	0.79	0.87	0.40
Corpus Christi	1.30	0.87	0.40	0.67	1.26	0.99	1.03	0.52	2.37	1.11	0.71	0.36
Dallas	1.30	0.63	1.15	1.11	1.97	1.62	0.67	1.15	2.01	1.07	0.87	1.30
El Paso	0.16	0.12	0.16	0.32	0.08	0.12	0.67	0.67	1.62	0.36	0.08	0.20
Fort Worth	1.86	0.71	1.26	1.11	1.30	1.58	0.71	0.79	1.97	1.50	0.71	0.99
Houston	1.50	1.03	0.91	1.30	2.21	1.23	2.05	1.15	2.01	1.58	1.38	1.74
Laredo	0.71	0.40	0.36	0.60	1.54	0.56	1.66	0.36	1.93	1.11	0.32	0.95
Lubbock	0.48	0.48	0.56	0.95	0.71	0.87	1.03	0.83	0.99	0.79	0.48	0.36
Lufkin	1.54	1.03	1.66	1.23	1.78	2.17	2.01	1.07	2.56	1.42	1.38	1.11
Odessa	0.48	0.24	0.08	0.20	0.79	0.56	0.63	0.40	1.23	0.52	0.36	0.44
Paris	1.07	0.71	1.86	1.23	3.04	1.50	1.74	0.60	1.66	1.74	1.11	1.62
Pharr	-	-	-	-	-	-	-	-	-	-	-	-
San Antonio	1.26	0.56	0.52	0.63	2.56	0.75	0.87	0.91	2.21	1.23	0.99	0.40
Tyler	1.26	1.11	1.38	1.66	1.30	2.21	1.42	0.95	2.64	2.01	1.11	1.03
Waco	2.21	1.03	2.09	1.03	1.50	1.97	1.46	0.56	2.52	2.25	0.75	0.75
Wichita Falls	0.52	0.56	0.83	1.15	1.34	1.15	0.99	0.91	1.70	1.34	0.63	0.56
Yoakum	1.82	0.67	1.82	1.23	2.45	1.54	1.62	0.83	2.72	1.34	0.91	0.99



Max. and Total Snowfall (in.)

City	Maximum Snow Depth (inches)						Total Snowfall Amount (inches)					
	Jan	Feb	Mar	Oct	Nov	Dec	Jan	Feb	Mar	Oct	Nov	Dec
Abilene	0.24	1.58				0.48	0.08	2.60			0.04	0.40
Amarillo	2.29	10.75	0.79	0.32	0.71	1.74	1.50	9.22	0.91	0.91	0.83	2.49
Atlanta	0.40	1.78					0.40	1.82				
Austin		0.08						0.08				
Beaumont												
Brownwood	0.48	0.79			0.24	0.40	0.60	0.67		0.12	0.16	
Bryan												
Childress	0.12	2.52	0.24		2.05	0.91	0.08	4.53	0.28		1.23	0.63
Corpus Christi												
Dallas		1.23	0.20			0.40	0.04	1.38	0.28			0.20
El Paso	0.12	0.20				0.12	0.28	0.04			0.04	0.12
Fort Worth		0.63				0.12	0.04	0.75				0.16
Houston												
Laredo												
Lubbock	0.52	1.89	0.08		0.75	0.63	0.52	2.37	0.20		0.67	0.79
Lufkin	0.16	0.36					0.44	0.32				
Odessa	0.99	0.36			0.08	0.79	0.71	0.40			0.08	1.03
Paris											0.04	
Pharr												
San Antonio	0.95	0.12				0.20	0.36	0.20				0.08
Tyler	0.12	0.52	0.12			0.12	0.08	0.95	0.24			0.24
Waco		0.60						0.52				
Wichita Falls		2.41				1.07		1.66	0.12		0.04	0.75
Yoakum												





TxDOT 0-6861: Improving Safety and Efficiency of Signalized Intersections During Inclement Weather

WEATHER MONITORING TECHNOLOGIES



Impacts of Severe Weather Events on Signal Operations

Weather Event/ Factors Affected	Snow	Ice/ Sleet	Heavy Rain	Wind	Fog/ Dust	Signal Timing Parameters/ Hardware Impacted
Sight/Decision Distance (Visibility)	✓	✓	✓		✓	Clearance Intervals, Video Detection Failure
Vehicle Acceleration		✓	✓			Clearance Intervals, Gap Settings, Phase Times
Vehicle Deceleration/ Braking		✓	✓			Clearance Intervals, Gap Settings, Phase Times
Reduced Prevalent Speed	✓	✓	✓	✓	✓	Clearance Intervals, Phase Times
Increased Gaps in Vehicle Stream		✓	✓	✓	✓	Phase times, Gap Settings





Weather Detection Needs

- Visibility
 - Decreased to a user defined threshold.
 - Due to fog, dust, rain, snow, or haze.
- Pavement Conditions
 - Detect water, ice, or snow accumulations on the pavement.
 - Snow and ice could be detected by infrared sensors.
 - Wet pavement could be detected by resistivity.
- Precipitation Intensity
 - Detect the intensity of rain



Wind Sensors (Anemometer)



Mechanical Anemometer
(Wind Speed Only)



Sonic Anemometer
(Wind Speed and
Wind Direction)



Propeller Anemometer
(Wind Speed and
Wind Direction)





Visibility Sensor – Camera-based

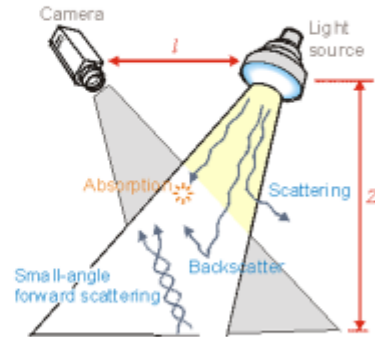

Visibility Sensor – Infrared

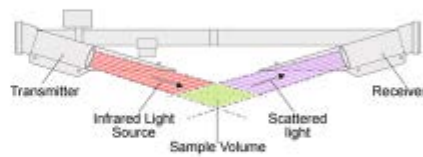

Forward Scatter Visiometer

High Sierra Visibility Sensor – Model 5434-00





Pavement Monitoring Systems

In-Pavement



Vaisala SSI Passive Pavement Sensor EP2000

Non-Intrusive



High Sierra Electronics Model 5433 "IceSight"



Environmental Sensor Station (ESS)

Roadway Element	Sensor
Air Temperature	Thermometer
Water Vapor (Dewpoint or Relative Humidity)	Hygrometer
Wind Speed and Direction	Conventional and Sonic Anemometer and Wind Vane or combined sensor (AeroSense)
Pavement Temperature, Pavement Freeze Point Temperature, Pavement Condition, Pavement Chemical Composition	Pavement Sensor
Subsurface Temperature	Subsurface Temperature Probe
Subsurface Moisture	Subsurface Moisture Probe
Precipitation Occurrence	Rain Gauge, Optical Present Weather Detector
Precipitation Type	Rain Gauge, Optical Present Weather Detector
Precipitation Intensity	Rain Gauge, Optical Present Weather Detector
Precipitation Accumulation	Rain Gauge, Optical Present Weather Detector, Hot-plate Type Precipitation Sensor
Snow Depth	Ultrasonic or Infrared Snow Depth Sensor
Visibility	Optical Visibility Sensor, Closed Circuit Television Camera
Atmospheric Pressure	Barometer
Solar Radiation	Solar Radiation Sensor
Terrestrial Radiation	Total Radiation Sensor
Water Level	Pressure Transducer, Ultrasonic Sensor, Float Gauge, or Conductance Sensor



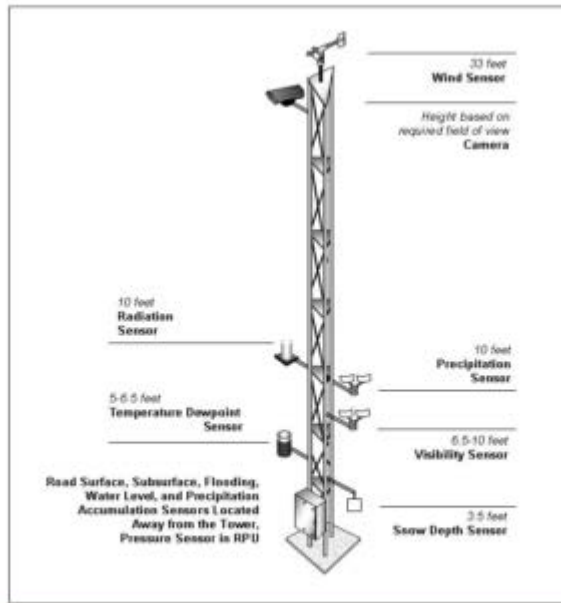

Tower-Mounted Sensors

Sensor	Mounting Recommendations
Air Temperature/Dew Point Sensor	5–6.5 ft above ground level. Where road frost is a concern, a second dew point sensor mounted closer to the pavement may help identify frost formation potential.
Optically based Precipitation Sensors (Rate, Type, and Amount)	10 ft above ground level to avoid contamination from debris.
Snow Depth Sensors	Install perpendicular to the surface at a height of approximately 3.5 ft. Sensor is based on ultrasonic or infrared emissions and sensitive to vibrations.
Visibility Sensors	6.5–10 ft above ground level to represent the eye level of drivers.
Wind Speed and Direction Sensor (anemometer)	33 ft above ground level. Obstructions to the wind flow should be avoided.





Steps for RWIS Needs

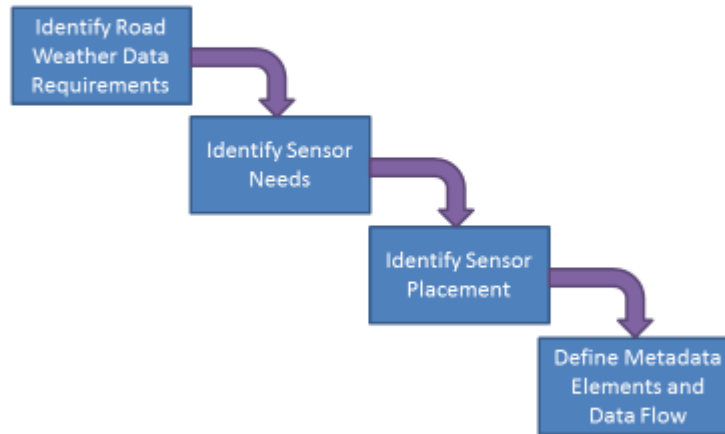

Weather Station Interface with the Traffic Signal System Requirements

- An isolated signalized intersection.
- A system of signals connected to a field master.
- A system of signal connected to a hardware (i.e., field) or central software master located at the traffic management center.





TxDOT 0-6861: Improving Safety and Efficiency of Signalized Intersections During Inclement Weather

SYSTEM ARCHITECTURE



General Physical Architecture

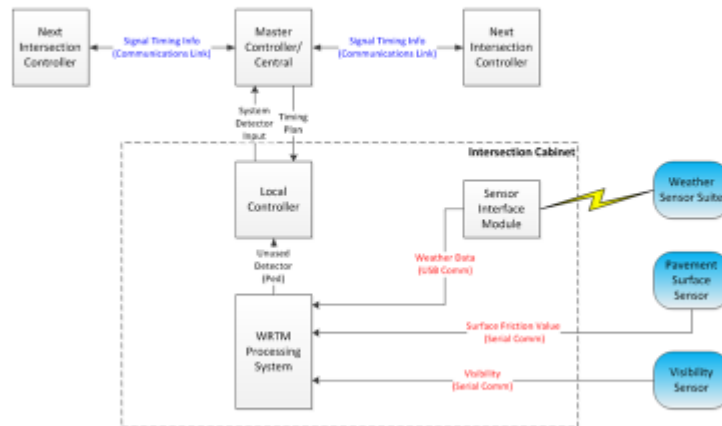



Visibility Sensor

- Non-intrusive technology
- Safe for the passing motorists.
- Measure current visibility conditions at least once per 5 minute interval.
- Real-time output to a remote location via a collocated cellular data system.
- Different types of physical communication interfaces: RS-232, RS-422, RS-485 and/or Ethernet.
- Software user interface for remote monitoring, configuration, and diagnostics.
- Mounted at least 20 ft. off ground



Pavement Condition Sensor

- Non-intrusive technology
- Indication of the general conditions:
 - Dry;
 - Wet/damp;
 - Ice/frost; and
 - Snow.
- Coefficient of friction.
- At least once per 5 minute interval.
- Communicate via a collocated cellular data system.
- Physical communication interfaces: RS-232; RS-422; RS 485; Ethernet.
- Software user interface for remote monitoring, configuration, and diagnostics.





Weather Station

- Vantage Pro 2 by Davis Electronics
- Wireless weather station
 - Rain Collector
 - Temperature and humidity sensors
 - Anemometer
- Solar powered
- Connected to computer



Weather Processing Unit

- Industrial computer
 - Collected data from various sensors
 - Select timing plans
 - Log actions
- Housed in traffic signal cabinet

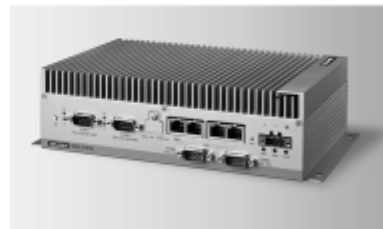



Timing Plan Selection Scheme

Time	Normal TOD Plan	Weather-Responsive Plan	Detector to Activate
7:00	1	5	Ped 1
15:30	2	6	Ped 3
20:00	3	7	Ped 5

- Special weather responsive plan corresponds to Time-of-Day plan
- Weather computer places call to unused detector
- Special detector activates weather responsive plan



TxDOT 0-6861: Improving Safety and Efficiency of Signalized Intersections During Inclement Weather

CASE STUDIES





US 287, Dumas, TX

- 7 intersection, TS-1 corridor
 - Master controller @ 1st St.
 - Coordinated through 8th St.
 - 14th St. operates isolated
 - Communications to master vis wireless
- Significant trucks volumes
- Snow/ice

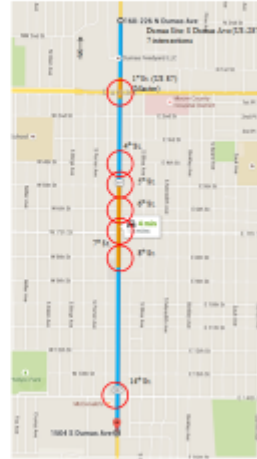

Climatology -- Dumas

	Jan	Feb	Mar	Apr	May	Jun
Average High in °F	49	52	61	69	78	87
Average Low in °F	22	24	31	40	50	60
Average Precipitation in Inches	0.63	0.51	1.26	1.3	2.17	2.4
Average Snowfall in Inches	3	2	3	1	0	0
	Jul	Aug	Sept	Oct	Nov	Dec
Average High in °F	92	90	82	71	59	48
Average Low in °F	65	64	56	43	31	23
Average Precipitation in Inches	2.44	2.87	1.85	1.38	0.75	0.83
Average Snowfall in Inches	0	0	0	0	1	3

Source: U.S. Climate Data. Available at <http://www.usclimatedata.com/climate/dumas/texas/united-states/ustx0388>





Weather Monitoring System - Dumas



Weather Responsive Timing Plan Selection Logic -- Dumas

- New TOD timing plan with 1st Street intersection included in the set of coordinated system.
- One new weather-responsive coordination plan.
- One new weather-responsive plan developed for the isolated intersection located at the 14th street.
- Industrial PC identifies the presence or absence of adverse weather
 - Triggers a call to a system detector at the 14th Street local controller via cabinet back panel.
 - System call passes to the master
 - Activate alternate timings plans in all local controllers.
 - Lack of a system call deactivates master override
 - Local controllers revert back to the normal timing plan for the coordinated system.





Evaluation Results - Dumas

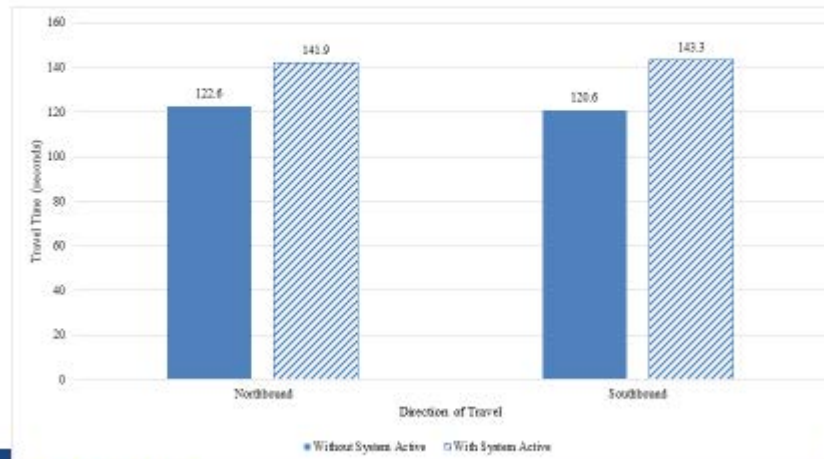

Texas A&M
Transportation
Institute



US 287, Burleson

- 10 intersections -- Eagle/Siemens M50 controllers in TS-2 cabinets
- Four coordinated TOD timing plans plus free operation
- WRTM system components are installed at Elk Drive

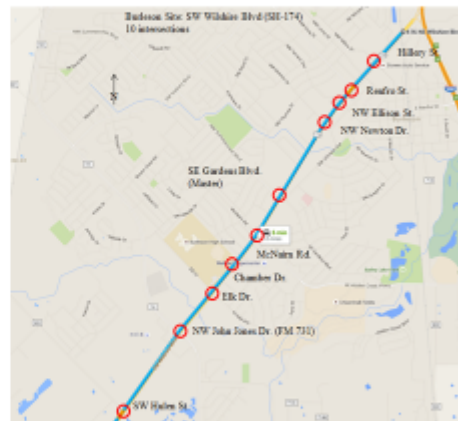

Texas A&M
Transportation
Institute



Climatology -- Burleson

	Jan	Feb	Mar	Apr	May	Jun
Average High in °F	56	59	67	76	82	89
Average Low in °F	33	37	44	52	61	69
Average Precipitation in Inches	2.09	2.64	3.62	2.8	4.53	4.02
Average Snowfall in Inches	-	-	-	-	-	-
	Jul	Aug	Sept	Oct	Nov	Dec
Average High in °F	94	95	87	77	66	56
Average Low in °F	72	72	68	54	44	35
Average Precipitation in Inches	2.4	2.28	3.23	4.29	2.6	2.52
Average Snowfall in Inches	-	-	-	-	-	-

Source: U.S. Climate Data. Available at

<http://www.usclimatedata.com/climate/burleson/texas/united-states/ustx0184>



Weather Monitoring System - Burleson



Pavement Surface Condition Monitoring System



Weather Monitoring Station





Weather Responsive Timing Plan Selection Logic -- Burleson

- Computer receives data from weather sensors
- Places call to one of four detectors. Each of these four detectors are configured as system detectors.
- The local controller passes system detector calls to the master controller
 - Switching normal operation to an alternate weather-responsive timing plan for current time.
 - Switching from one alternate weather-responsive timing plan to another alternate weather responsive timing plan (i.e., from AM-peak to noon-peak).
 - Switching from an alternate weather responsive timing plan to an appropriate normal plan.
- Researchers programmed the master to use Occ1, Occ2, Que1, and Que2 channels to activate one of four alternate timing plans.



Evaluation Results -- Corridor Travel Times

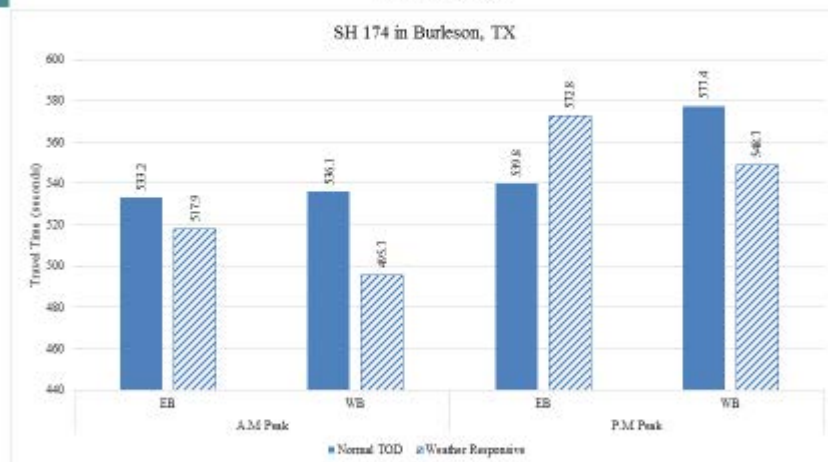



Evaluation Results – Approach Delay

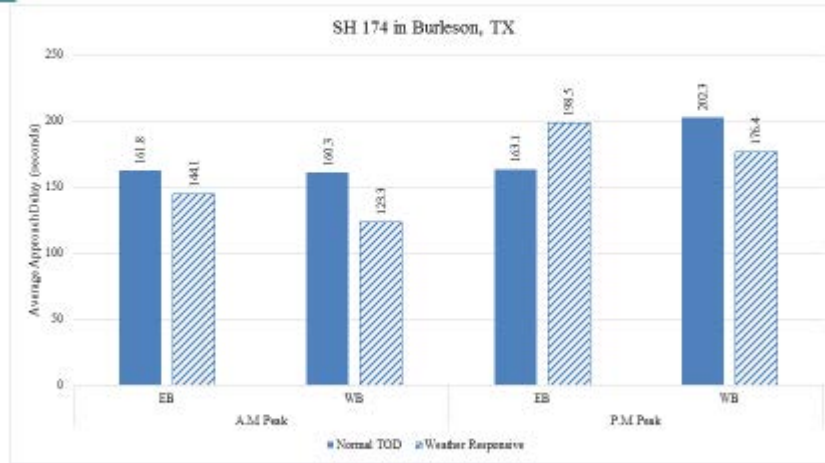

Evaluation Results – Stop Delay

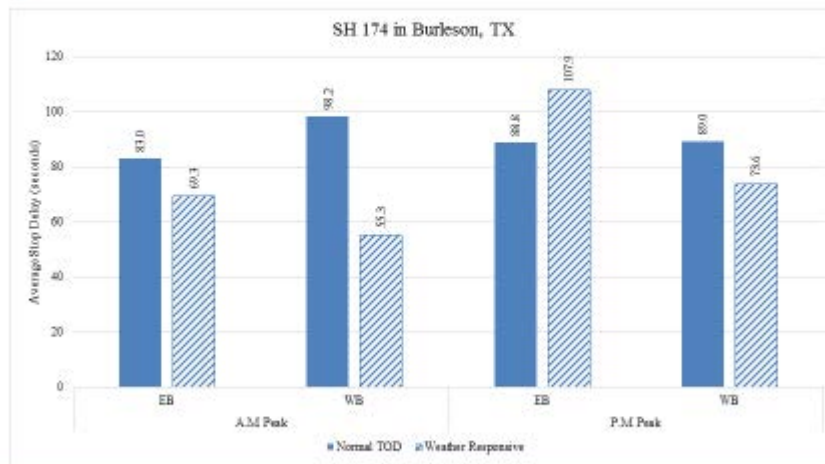



Evaluation Results – Number of Stops

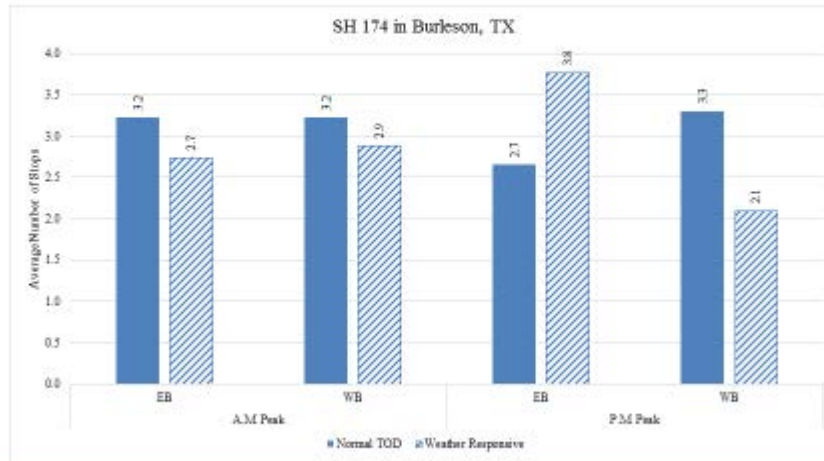

Texas A&M
Transportation
Institute



NASA Road 1, Nassau Bay

- Four TOD timing plans plus “Free” operations
- Connected to central system
- Peer-to-peer communications between signals



Texas A&M
Transportation
Institute



Climatology – Nassau Bay

	Jan	Feb	Mar	Apr	May	Jun
Average High in °F	62	65	71	77	83	88
Average Low in °F	43	47	53	59	67	72
Average Precipitation in Inches	4.49	2.91	3.23	3.31	4.65	6.42
Average Snowfall in Inches	-	-	-	-	-	-
	Jul	Aug	Sept	Oct	Nov	Dec
Average High in °F	91	91	87	80	72	64
Average Low in °F	73	73	69	60	52	45
Average Precipitation in Inches	4.57	5.16	7.17	5.94	4.92	4.06
Average Snowfall in Inches	-	-	-	-	-	-

Source: U.S. Climate Data. Available at

<http://www.usclimatedata.com/climate/dickinson/texas/united-states/ustx2181>



Weather Responsive Timing Plan Selection Logic – Nassau Bay

- For each of four coordinated TOD plan, developed corresponding alternate(weather-responsive) plan.
- Weather responsive computer located at Nassau Bay intersection
 - Matching timing plans to TOD schedule.
 - When it detects a weather condition, computer sends a signal to one of four preconfigured detector inputs
 - The inputs correspond to the TOD
- Controller activates the desire alternate timing plan via controller’s programmable logic capability.





Evaluation Results – Corridor Travel Time

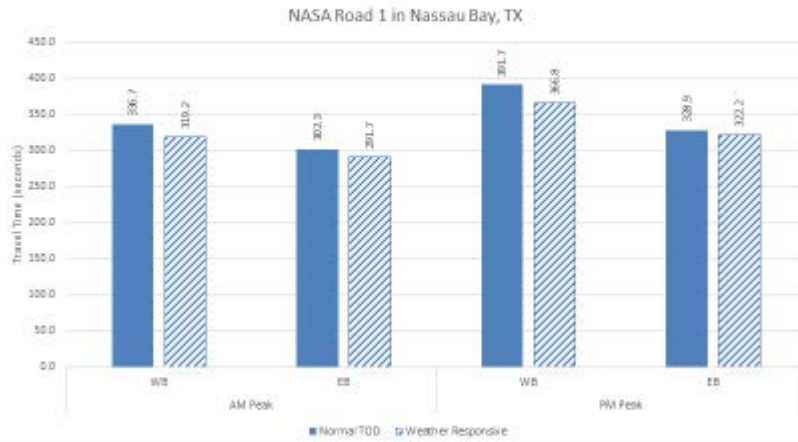

Evaluation Results – Approach Delay

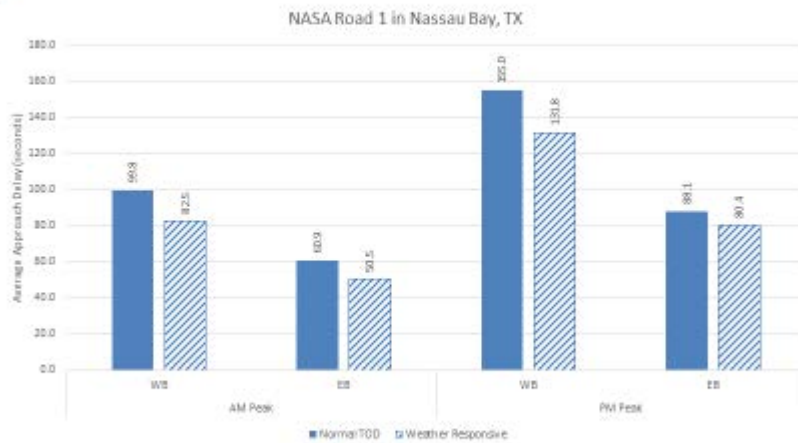



Evaluation Results – Stop Delay

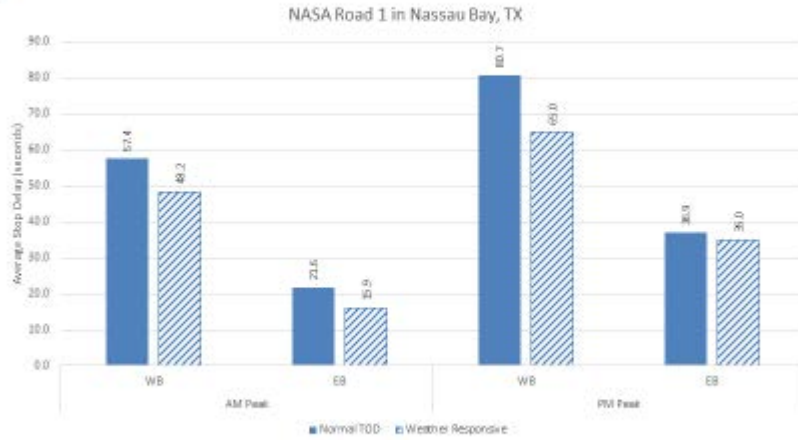

Evaluation Results – Number of Stops

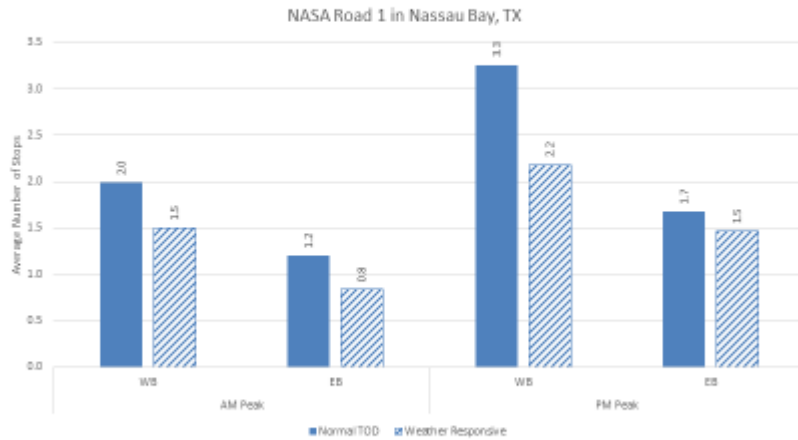



TxDOT 0-6861: Improving Safety and Efficiency of Signalized Intersections During Inclement Weather

LESSON LEARNED



Weather and Pavement Monitoring Equipment

- Pavement monitoring systems need to measure actual travel conditions
 - Detect conditions in the wheel path
 - Pointed at the departure side of the intersection, if possible, and outside of the crosswalk.
 - Pavement area outside of the wheel path to remain damp while the wheel path is generally dry.
- Weather stations are not a necessary part of a weather responsive traffic signal system deployment.
 - Provide supplemental information
 - Does not provide any direct input into the decision-making process.
- Visibility sensors are costly -- conduct benefit-cost and risk analysis to determine if sensors justifiable.





Weather Responsive Timing Plan

- Implement only at critical intersection or systems where operations severely impacted
- Applicable for wide range of conditions
- Should not vary significantly for existing plans
 - Use similar splits
 - Limited changes to offsets and phase sequence
- May want to consider lengthening vehicle change and clearance intervals during weather conditions
- Conduct pilot to assess impacts prior to full implementation.



System Deployment and Calibration

- Requires extensive data sets
 - No two weather events the same
 - Correlate traffic operations, signal performance, and weather conditions.
- Used two factors
 - Pavement sensor status
 - Friction factor
- Thresholds for activating/deactivating weather responsive timing plans should be calibrated in the field





Evaluating System Performance

- Difficult to assess the degree to which modifying signal operations provides a benefit during weather conditions
- A strategy that works in one location may not always work in other parts of the state
- Further field-study based research is needed to determine how to determine when and where such systems should be deployed



Questions

