

# **INTERSECTION VIDEO DETECTION FIELD HANDBOOK: AN UPDATE**

by

Dan Middleton, P.E.  
Program Manager  
Texas Transportation Institute

Jim Bonneson, P.E.  
Program Manager  
Texas Transportation Institute

Ryan Longmire  
Engineering Research Associate  
Texas Transportation Institute

and

Hassan Charara  
Research Scientist  
Texas Transportation Institute

Report 0-6030-P3  
Project 0-6030

Project Title: Guidelines for Best Use of Video Detection for Stop Bar Presence Detection

Performed in cooperation with the  
Texas Department of Transportation  
and the  
Federal Highway Administration

August 2009  
Published: December 2010

TEXAS TRANSPORTATION INSTITUTE  
The Texas A&M University System  
College Station, Texas 77843-3135



## **DISCLAIMER**

The contents of this report reflect the views of the authors, who are solely responsible for the facts and accuracy of the data, the opinions, and the conclusions presented herein. The contents do not necessarily reflect the official view or policies of the Texas Department of Transportation (TxDOT) or the Federal Highway Administration (FHWA). This report does not constitute a standard or regulation, and its contents are not intended for construction, bidding, or permit purposes. The use of names or specific products or manufacturers listed herein does not imply endorsement of those products or manufacturers. The engineer in charge of the project was Dan Middleton, P.E. #60764.

## **NOTICE**

The United States Government and the State of Texas do not endorse products or manufacturers. Trade or manufacturers' names appear herein solely because they are considered essential to the object of this document.

## **ACKNOWLEDGMENTS**

This project was conducted in cooperation with the Texas Department of Transportation and the Federal Highway Administration. The authors wish to gratefully acknowledge the contributions of several persons who made the successful completion of this research possible. This especially includes the project director, Mr. Henry Wickes. Special thanks are also extended to the following members of the Project Monitoring Committee: Mr. Al Kosik, Mr. Carlos Ibarra, Mr. Dan Maupin, Mr. David Danz, Mr. Derryl Skinnell, Mr. Adam Chodkiewicz, and Mr. Wade Odell of the Texas Department of Transportation. Finally, personnel who were especially helpful in field data collection activities were Mr. Mark Schoeneman of the Bryan District and Mr. Pat Walker of the City of College Station.

# TABLE OF CONTENTS

	<b>Page</b>
<b>LIST OF FIGURES</b> .....	vi
<b>LIST OF TABLES</b> .....	vii
<b>CHAPTER 1. INTRODUCTION</b> .....	1
OBJECTIVE .....	1
SCOPE .....	1
<b>CHAPTER 2. DESIGN GUIDELINES</b> .....	3
OVERVIEW .....	3
OPTIMAL CAMERA LOCATION AND FIELD OF VIEW .....	3
GUIDELINES.....	4
<b>CHAPTER 3. OPERATIONS GUIDELINES</b> .....	13
OVERVIEW .....	13
OPTIMAL DETECTION ZONE LAYOUT .....	13
GUIDELINES.....	14
<b>REFERENCES</b> .....	21

## LIST OF FIGURES

<b>Figure</b>		<b>Page</b>
1	Variables Defining a Camera's Location and Field of View .....	3
2	Illustrative Optimal Camera Location and Field of View .....	4
3	Common Camera Mounts .....	5
4	Alternative Camera Locations .....	5
5	Schematic Showing Cameras and Detection Zone Placement .....	8
6	Illustrative Optimal Detection Zone Layout .....	13
7	Alternative Detection Modes .....	17

## LIST OF TABLES

<b>Table</b>		<b>Page</b>
1	Minimum Camera Height to Reduce Adjacent Lane Occlusion .....	6
2	Selection of Upstream Detection Zone Distances for VIVDS Detectors .....	7
3	Upstream Camera and Detection Zone Locations .....	8
4	Guidance for Locating Detection Zones and Individual Detectors .....	14
5	Stop-Line Detection Zone Length for VIVDS Applications .....	15
6	Advance Detection Zone Layout for VIVDS Applications .....	16





# CHAPTER 1. INTRODUCTION

## OBJECTIVE

This handbook is intended to assist engineers and technicians with the design, layout, and operation of a video imaging vehicle detection system (VIVDS). This assistance is provided in three ways. First, the handbook identifies the optimal detection design and layout. Second, it provides guidelines for achieving an optimal or near-optimal camera location and field of view. Third, it provides guidelines for laying out the VIVDS detectors such that they will provide safe and efficient operation. Finally, guidance is provided on the need for and schedule of VIVDS maintenance activities.

Some of the guidance provided in this document was obtained from a review of the literature and from interviews with TxDOT staff. Some guidance was also developed using the geometric relationships of camera optics and the principles of detection design. The report by Bonneson and Abbas (*1*) documents these development activities. In particular, it describes the rationale underlying the guidance and the validation of some guidelines based on simulation or field data.

## SCOPE

The guidelines provided in this handbook address the use of a VIVDS to provide vehicle presence detection at a signalized intersection or interchange in Texas. The facility can be new or existing. It can be in an urban or rural environment and on a collector or arterial roadway. To the extent practical, the guidelines are applicable to all VIVDS products. They are applicable to detection designs that use one camera (for each intersection approach monitored) to provide detection at the stop line and, if needed, detection in advance of the stop line.

The guidelines apply to intersections and interchanges that use one signal controller. The research does not explicitly address the use of a VIVDS to facilitate coordinated signal operation, beyond that needed to affect stop-line detection in support of such operation. The research does not address the use of a VIVDS for measuring vehicle count, speed, headway, occupancy, or other traffic characteristics beyond that needed for basic intersection (or interchange) control using presence-mode detection.

The terms “detection design,” “detection layout,” and “detection zone” are used frequently in this handbook. *Detection design* refers to the selection of camera location and the calibration of its field of view. *Detection layout* refers to the location of detection zones, the number of detection zones, and the settings or detection features used with each zone. A *detection zone* is defined to be one or more VIVDS detectors that are configured (or linked) to act as one detector and that are separated from upstream and downstream detection zones by at least the effective length of a vehicle.



## CHAPTER 2. DESIGN GUIDELINES

### OVERVIEW

This chapter addresses several important VIVDS design elements. These elements include camera mounting location and field-of-view calibration. Design considerations include the camera's height, offset, distance from the stop line, pitch angle (relative to horizontal plane), and lens focal length. The first three considerations refer to "camera location" and the last two considerations refer to the "field-of-view" calibration. [Figure 1](#) illustrates the variables associated with these considerations. This chapter also addresses intersection lighting, which is an important design consideration as it relates to VIVDS performance.

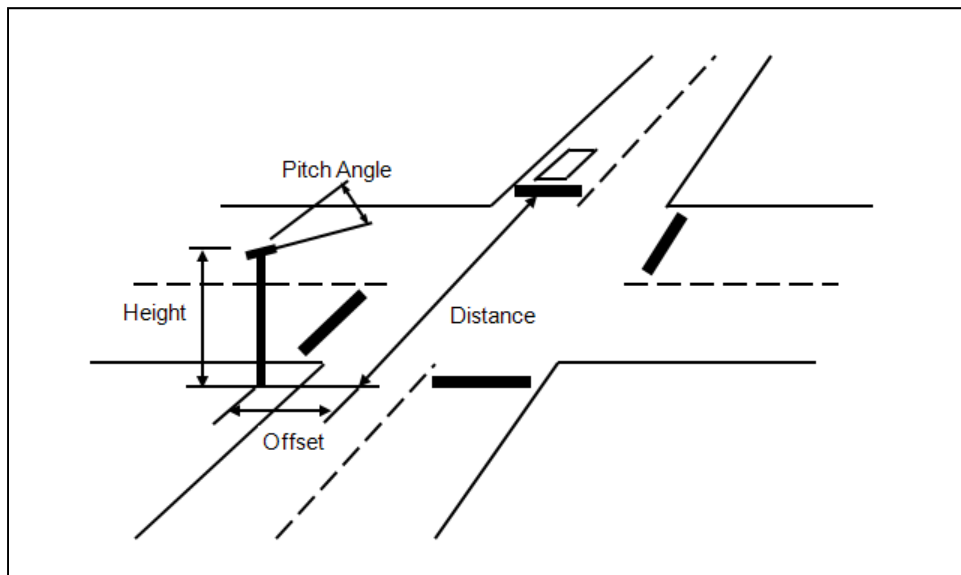
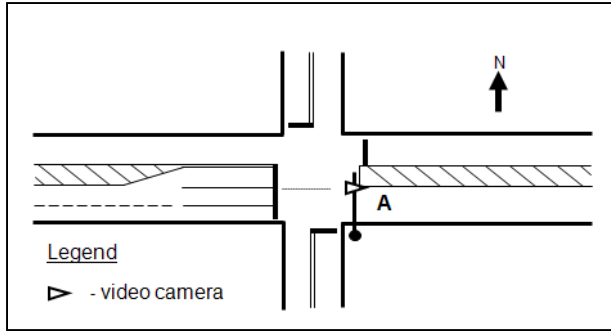

**Figure 1. Variables Defining a Camera's Location and Field of View.**

### OPTIMAL CAMERA LOCATION AND FIELD OF VIEW

#### Camera Location

An optimal camera location is one that maximizes detection accuracy. As such, an optimal location is one that provides a stable, unobstructed view of each traffic lane on the intersection approach. The view must include the stop line and extend back along the approach for a distance equal to that needed for the desired detection layout. [Figure 2a](#) shows an example of an optimal camera location identified by the letter "A." [Figure 2b](#) shows its associated field of view.



**a. Illustrative Optimal Camera Location.      b. Illustrative Optimal Field of View.**

**Figure 2. Illustrative Optimal Camera Location and Field of View.**

### Field-of-View Calibration

Calibration of the camera field of view is based on a one-time adjustment to the camera pitch angle and the lens focal length. An optimal field of view is one that has the stop line parallel to the bottom edge of the view and in the bottom one-half of this view. The optimal view includes all approach traffic lanes. The focal length would be adjusted such that the approach width, as measured at the stop line, equates to 90 to 100 percent of the horizontal width of the view. Finally, the view must exclude the horizon. An optimal field of view is shown in [Figure 2b](#).

### GUIDELINES

This section describes VIVDS design guidelines for daytime applications. These guidelines can be used to define a camera location and field of view that maximize detection accuracy. The following topics are addressed in this section: camera location and field-of-view calibration. There is information pertaining to night applications of video later in this document.

### Camera Location

Desirable camera heights and offsets are often limited by the availability of structures that can provide a stable camera mount. Considerations of height, offset, and stability often require a compromise location that is subjectively determined to provide the best performance. Camera mounting locations vary widely with each intersection. Typical locations include luminaire arms, signal head mast arms, and signal poles. [Figure 3](#) shows two commonly used camera mounts. [Figure 3a](#) shows a camera mounted on a mast arm. [Figure 3b](#) shows a camera mounted on a luminaire arm on a mast arm pole.



a. Mast Arm Camera Mount.

b. Luminaire Arm Camera Mount.

**Figure 3. Common Camera Mounts.**

*Camera Offset*

As shown in [Figure 2](#), the optimal camera offset is approximately in the center of the approach being monitored. However, this location can vary slightly, depending on whether the approach being monitored has a left-turn bay. If it has a left-turn bay, the preferred camera location is over the lane line separating the left-turn bay and the adjacent (oncoming) through lane. [Figure 4](#) shows this location as point “A” as applied to the eastbound approach. If the approach does not have a left-turn bay, the preferred location is centered on the approach lanes, as shown by location “B” for the westbound approach. Installers can use other camera locations such as locations “C” and “D” when locations “A” or “B” are not available or when they do not provide the desired camera height.

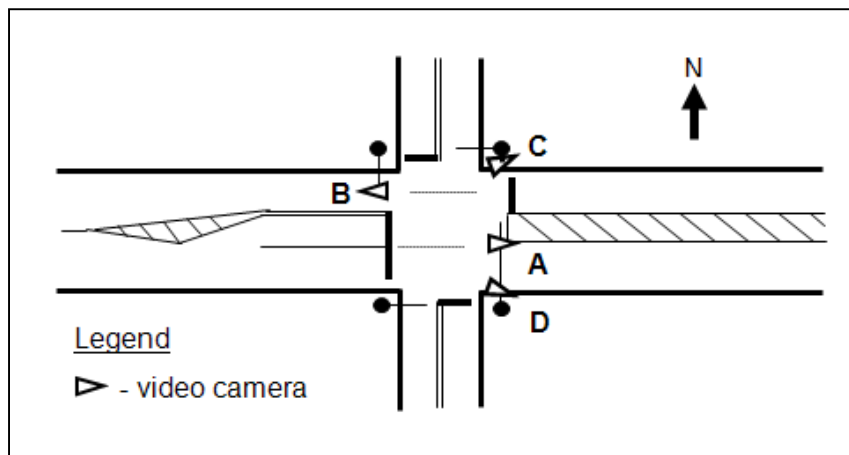

**Figure 4. Alternative Camera Locations.**

## Camera Height

This section describes guidelines for determining the minimum camera height for a specified camera offset and distance to the stop line by defining two minimum height controls. The first minimum height control is intended to minimize the effect of adjacent-lane occlusion. The second control is intended to provide acceptable detection accuracy. The first control applies to all VIVDS installations. Both controls are applicable to high-speed approaches where advance detection is needed. In this situation, the larger of the two minimum values would define the applicable minimum height criterion.

**Minimum Height to Reduce Adjacent Lane Occlusion.** Table 1 indicates the minimum height needed to reduce adjacent-lane occlusion using a passenger car as the design vehicle. Interpolation between cell values is appropriate for offsets intermediate to the values listed. A recommended minimum height of 24 ft gets the camera above some of the dirt, spray, and mist that can collect on the camera lens at lower heights and is available by mounting on the mast arm with a 5-ft riser. Camera locations that require camera heights in excess of about 35 ft should be avoided unless a stiffer than normal pole is available to minimize camera movement. A camera mounted in the center of the approach is associated with the lowest minimum height, and this minimum increases with offset.

**Table 1. Minimum Camera Height to Reduce Adjacent Lane Occlusion.**

Camera Location	Lateral Offset, ft <sup>a</sup>	No Left-Turn Lanes				One Left-Turn Lane				Two Left-Turn Lanes			
		Through+Right Lanes <sup>b</sup>				Through+Right Lanes <sup>b</sup>				Through+Right Lanes <sup>b</sup>			
		1	2	3	4	1	2	3	4	1	2	3	4
Left Side of Approach		Minimum Camera Height (H <sub>0</sub> ) <sup>c</sup> ft											
	-55		44	48	53	44	48	53	57	48	53	57	62
	-45		36	41	45	36	41	45	50	41	45	50	54
	-35		29	33	38	29	33	38	42	33	38	42	47
	-25		24	26	30	24	26	30	35	26	30	35	39
	-15		24	24	24	24	24	24	27	24	24	27	32
Center	0		24	24	24	24	24	24	24	24	24	24	24
Right Side of Approach	5		24	24	24	24	24	24	24	24	24	24	24
	15		24	24	24	24	24	24	27	24	24	27	32
	25		24	26	30	24	26	30	35	26	30	35	39
	35		29	33	38	29	33	38	42	33	38	42	47
	45		36	41	45	36	41	45	50	41	45	50	54
	55		44	48	53	44	48	53	57	48	53	57	62

<sup>a</sup> Lateral offset of camera measured from the center of the approach lanes (including turn lanes).

<sup>b</sup> Total number of through and right-turn lanes on the approach.

<sup>c</sup> Based on a vehicle height  $h_v$  of 4.5 ft and vehicle width  $w_v$  of 6.0 ft.

Source: Adapted from Reference (1).

**Minimum Height for Advance Detection.** Research Project 0-5774 (2) found that TxDOT should adopt a maximum *aspect ratio* (ratio of horizontal distance to farthest upstream detector divided by camera mounting height) of 10:1. However, using a single camera on the back side of the intersection would result in camera heights ranging from 42 ft to 66 ft. This entire range is beyond the height of poles normally found in the field and that would be sufficiently stable. Therefore, TxDOT should install a second camera pole upstream of the intersection on high-speed approaches. Besides, the use of two cameras reduces the role of the stop line camera and allows improved aim and focus, which would facilitate optimum use. One camera might be adequate for speeds slower than 50 mph.

Table 2 indicates the selected distances for each design speed to identify the beginning of the dilemma zone (defined as 5.5 sec travel time) compared to the current TxDOT point detector distances from the stop line. This document generally uses the more conservative (larger) values for each design speed. For this range of speeds, TxDOT currently uses three detection points when point detectors are used. However, VIVDS performance improves with only two detection points due to the camera angle and its elongation of detection zones. This document addresses the location of  $x_2$  later. Table 3 provides the camera heights needed for advance detection and requiring an upstream pole where mounting cameras within the intersection results in aspect ratios greater than 10:1. Minimum camera heights range from 25 to 45 ft, depending on the distance between the camera and stop line and on the approach speed limit.

**Table 2. Selection of Upstream Detection Zone Distances for VIVDS Detectors.**

Speed Limit ( $V_{85}$ )	$x_1$ (ft) <sup>a</sup>	5.5 sec TT <sup>b</sup>	Selected $x_1$ (ft)
50 mph	350	404	400
55 mph	410	445	445
60 mph	475	485	485
65 mph	540	526	540
70 mph	600	566	600

<sup>a</sup> Based on current TxDOT specification for dilemma zone detectors (omit center detectors where used for inductive loops).

<sup>b</sup> TT: Travel time.

Figure 5 shows the dimensions that are pertinent to this discussion. The installation crew should measure distances  $x_1$  and  $x_2$  (shown below) from the stop line location. Table 3 uses a maximum aspect ratio of 10:1 and indicates the placement of poles, cameras, and detection zones. Column 2 provides camera heights from 25 ft to 45 ft. Poles taller than about 35 ft would require added stiffness to minimize camera movement, so TxDOT should generally consider using pole heights of 25 ft to 40 ft. Pole locations in these tables ( $x_{pole}$ ) are measured from the stop line, so a value of zero would be at the stop line (at some appropriate offset) and a value of 140 ft would be located at the prescribed distance measured parallel with the roadway. The values provided use a passenger car as the design vehicle, and all distances are measured in feet.

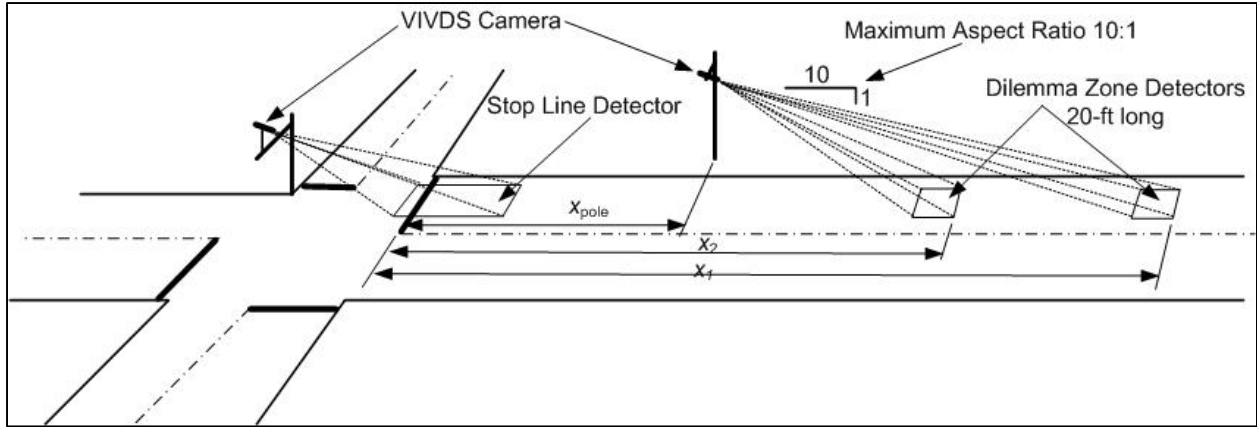

**Figure 5. Schematic Showing Cameras and Detection Zone Placement.**

For example, a camera height ( $H_c$ ) at the stop line of 40 ft on a 50-mph approach (see Table 3 shading) would have the entry detector (farthest from the stop line,  $x_1$ ) at 400 ft (10:1 ratio), and the second detector ( $x_2$ ) would be at 260 ft from the stop line. These values assume a controller passage time of 1.0 sec and detection zone length of 20 ft in all cases. This design provides dilemma zone protection for a 10 mph range of speeds with the high end being the 85<sup>th</sup> percentile speed and the low end being 10 mph less than the 85<sup>th</sup> percentile speed. Vehicles traveling slower than this range will theoretically gap-out. Additional information in Chapter 3 provides controller extension settings to provide safe gap-out for slower vehicles. These settings are not based on actual field monitoring, so the installer should monitor the intersection following setup to ensure safe operation.

**Table 3. Upstream Camera and Detection Zone Locations.**

Design Speed ( $V_{85}$ )	Upstream Detector Distance $x_1$	Second Detector Distance $x_2$	Camera Height, $H_c$ (ft)				
			25	30	35	40	45
			Pole Distance from Stop Line, $x_{pole}$ (ft)				
50 mph	400	260	150	100	50	0	0
55 mph	445	300	180	130	80	30	0
60 mph	485	330	220	170	120	70	20
65 mph	540	380	290	240	190	140	90
70 mph	600	430	350	300	250	200	150

**Height and Stability.** Research indicates that increasing camera height tends to improve accuracy, provided that there is minimal camera motion. However, there is a “point of diminishing returns” with respect to camera height when the camera support structure is susceptible to instability. Specifically, data indicate that camera heights of 35 ft or more may be associated with above-average errors *unless* the camera is mounted on a stable pole.



**Alternative Technology.** The design process should consider at least one other non-intrusive detection technology for dilemma zone protection on high-speed approaches. Findings through field tests and experience from Utah DOT (2) indicate that a relatively new radar detector is a viable option for replacing VIVDS for dilemma zone detection. In TTI field tests under sub-optimal conditions, it out-performed VIVDS much of the time even during daylight hours and in perfect weather conditions when VIVDS is known to perform at its best. Three critical factors related to radar detection rank it even higher when compared to VIVDS:

- inclement weather and poor light conditions do not affect its performance,
- changes in approach speeds do not require changes in the detector, and
- most lane shifts do not require changes in its orientation.

Either option (VIVDS or radar) requires a separate detector for the stop line if such detection is deemed necessary.

The initial cost is also an important consideration in the decision regarding which technology to use. The comparison in reference (2) evaluated the cost of VIVDS against the radar detector. For intersection approaches with up to three lanes upstream (before introduction of turning lanes), the cost of detection was about the same for each design speed in the range of 50 to 70 mph (including upstream pole and camera where needed). The referenced study did not evaluate life-cycle cost due to lack of historical cost data on the radar detector, but it should hold the advantage over VIVDS.

#### *Combined Offset and Height Considerations*

A common TxDOT practice is to install cameras on a 5-ft riser on the signal head mast arm as indicated in Figure 3a. This placement can achieve the desired height and offset. Unfortunately, the minimum camera height for some approaches typically requires a right-side or left-side mount (as denoted by the letters “C” and “D” in Figure 4). Both locations have the camera mounted on the signal pole at the necessary height or on a luminaire arm extending from the pole as illustrated in Figure 3b.

The choice between a right-side or a left-side mount is dependent on the phase sequence used to control the subject approach. For approaches without a left-turn phase, installers should mount the camera on the right side, far corner of the intersection (i.e., “D” in Figure 4).

For approaches with a left-turn phase and bay, location “D” is problematic because the projected outline of a tall through vehicle can extend into the left-turn bay and unnecessarily call the left-turn phase. To avoid this problem, install the camera on the left-side, far corner of the intersection (i.e., “C” in Figure 4). This location minimizes false calls for service to the left-turn phase; any false calls for the through phase by a tall left-turn vehicle would have limited impact because through vehicles are present during most cycles. Installers should use a directional detector for the left-turn detectors to prevent unnecessary calls by departing vehicles. If the directional detector is not effective, the installer could set a delay for this detector.

## Field-of-View Calibration

Calibration of the camera field of view is based on a one-time adjustment to the camera pitch angle and the lens focal length. An optimal field of view is one that has the stop line parallel to the bottom edge of the view and in the bottom one-half of this view. The optimal view also includes all approach traffic lanes. The focal length would be adjusted such that the approach width, as measured at the stop line, equates to 90 to 100 percent of the horizontal width of the view. Finally, the view must exclude the horizon. [Figure 2b](#) shows an example of an optimal field of view.

The optimal field of view is not achievable for some right-side and most left-side camera offsets. In these situations, the approach width may not be parallel to the bottom of the view and it may not equate to 90 percent of the horizontal width of the view. A 90-percent width for the approach may be particularly difficult to achieve when advance detection is used. Nevertheless, the field of view should always be adjusted to maximize the approach width (as a percent of the view) at the stop line. Practical minimum widths are 40 and 60 percent for left-side and right-side camera offsets, respectively.

Two camera adjustments are available to minimize the deleterious effects of sun glare (or reflection) on detection accuracy. The most important is to eliminate the horizon from the camera view through adjusting the pitch angle of the camera. The minimum pitch angle is about 3.0 degrees (from horizontal). Adjusting the visor on the camera housing will also help in many cases. VIVDS processors have the ability to minimize the effect of occasional glare by automatically invoking a maximum recall on the troubled approach when it detects glare.

The camera field of view should avoid objects that are brightly lit in the evening hours, especially those that flash or vary in intensity. These sources can include luminaires, signal heads, billboard lights, and commercial signs. The light from these sources can cause the camera to reduce its sensitivity (by closing its iris), which results in reduced detection accuracy. If these light sources are located near a detection zone, they can trigger unnecessary calls.

If the pitch angle or focal length cannot be adjusted to avoid glare and brightly lit objects, then the installer should consider alternative camera locations. If such locations cannot be found, then careful detection zone layout can minimize the effect of light sources or power lines on detection accuracy.

## Intersection Lighting

Intersections that have a minimal level of area lighting may experience a higher level of unneeded calls and will experience premature detection with video. In other words, detection of the headlights will occur well ahead of the actual leading edge of the vehicle. Video detectors switch to detection of headlights at night, so their night activation characteristics are significantly different from daytime. Vehicle headlights in crossing lanes can trigger detections as well, possibly resulting in increased intersection delay. Adding street lighting or increasing street lighting can reduce this problem, partly by reducing vehicle shadows.

## **Communications**

Significant signal degradation can occur when using coaxial cable lengths of 1000 ft or more. When a length of 1000 ft or more is anticipated, installers should avoid splices in the cable and should use separate conduits for coaxial cable and power cable. The concept of using wireless communication between VIVDS cameras and processors has not been successful. A more common trend is integrating the processor in the camera housing.



## CHAPTER 3. OPERATIONS GUIDELINES

### OVERVIEW

This chapter describes guidelines for VIVDS operation and maintenance. VIVDS operation is defined by its detection zone layout, which includes consideration of zone location, detection mode, detector settings, and controller settings. VIVDS maintenance is defined by the on-site performance checks conducted after the initial installation and the routine maintenance activities that follow installation.

### OPTIMAL DETECTION ZONE LAYOUT

Detection zone layout is an important factor influencing the performance of the intersection. There are several factors to consider when laying out each zone. These factors include: zone location relative to the stop line, the number of VIVDS detectors used to constitute the zone, whether the detectors are linked using Boolean logic functions, whether the zone monitors travel in a specified direction, and whether the zone's call is delayed or extended. [Figure 6](#) illustrates an optimal detection zone layout.

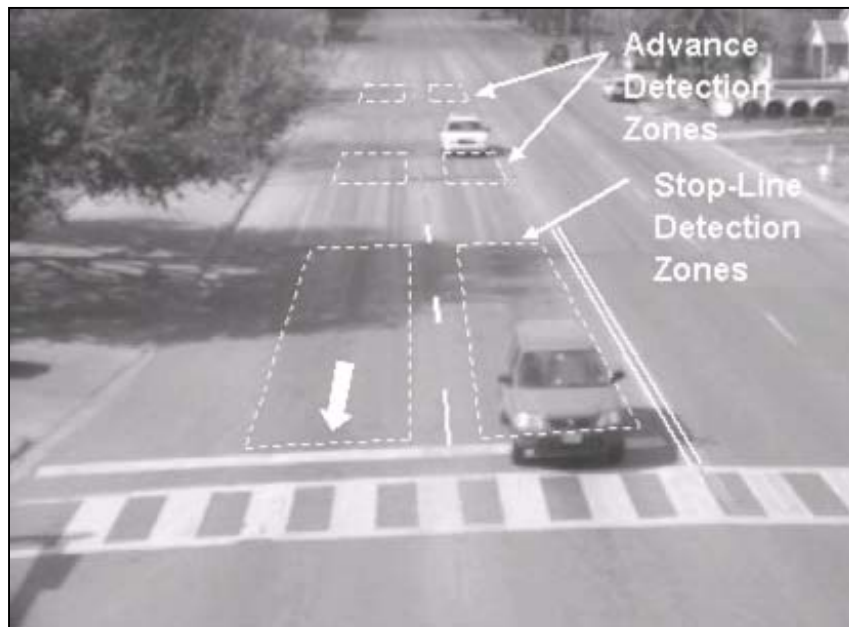

**Figure 6. Illustrative Optimal Detection Zone Layout.**

## GUIDELINES

This section describes guidelines for detection zone layout and operation. Detection zone layout guidelines include zone location, detection mode, detector settings, and controller settings. VIVDS operation guidelines describe activities needed to verify the adequacy of the initial installation and the checks needed during a routine maintenance visit. These guidelines are for daylight operation of video since nighttime detections by video are different due to premature detections of the leading edge of the headlight “bloom” instead of the front of the vehicle. This document provides additional information on night detections later.

### Detection Zone Layout

#### *Detection Zone Location*

Like inductive loops, VIVDS detectors can be placed within a lane or across several lanes. They can be placed at the stop line or several hundred feet in advance of it. The VIVDS product manuals offer some guidance for locating a VIVDS detection zone and the detectors that comprise it. [Table 4](#) summarizes and describes these guidelines.

**Table 4. Guidance for Locating Detection Zones and Individual Detectors.**

Application	Guideline	Rationale
Stop-Line Detection	Stop-line detection zone typically consists of several detectors extending back from the stop line.	For reliable queue service, stop-line detection typically requires monitoring a length of pavement 80 ft or more in advance of the stop line.
	Put one detection zone downstream of the stop line if drivers tend to stop beyond the stop line.	Avoid having one long detector straddle a pavement marking.
	Use specific techniques to heighten detector sensitivity (e.g., overlap individual detectors slightly).	Vehicle coloration and reflected light may combine to make some vehicles hard to detect.
Advance Detection	Advance detection typically consists of two detectors strategically located on the approach.	Advance detection uses passage time to extend the green for vehicles in the dilemma zone.
	Advance detectors can reliably monitor vehicles at a distance (from the camera) of up to 350 ft, provided the field of view is optimal and aspect ratio $\leq 10:1$ .	Detection accuracy degrades and detector setup difficulty increases as the location being monitored by the VIVDS becomes more distant from the camera.
Individual Detector	Avoid having pavement markings cross or straddle the boundaries of the detection zone.	Camera movement combined with high-contrast images may trigger an unneeded call.
	The individual detector length should approximately equal that of the average passenger car.	Maximize sensitivity by correlating the number of image pixels monitored with the size of the typical vehicle being detected.

**Stop-Line Detection.** This section describes guidelines for determining an efficient detection zone layout for stop-line detection. Typical applications of stop line detection are low-speed intersection approaches and in left-turn bays. The next section provides guidelines for determining the layout for advance detection zones.

Table 5 lists the recommended stop line detection zone lengths. Interpolation between cell values is appropriate for distances or heights intermediate to the values listed. The recommended lengths require a 0.0-s controller passage time. These recommended values should result in lower delay than that realized by longer passage times or shorter detection zone lengths.

**Table 5. Stop-Line Detection Zone Length for VIVDS Applications.**

Distance between Camera and Stop Line, <sup>a</sup> ft	Camera Height, ft				
	24	28	32	36	40
	Stop-Line Detection Zone Length, <sup>b</sup> ft				
50	100	100	100	100	100
100	90	90	95	95	95
150	80	85	85	90	90

<sup>a</sup> Distance between the camera and the stop line, as measured parallel to the direction of travel.

<sup>b</sup> Lengths shown are based on a 0.0-s passage time setting.

During the initial VIVDS setup, the installer should measure the detection zone length along the roadway with a distance wheel. Mark the most distant upstream edge with a traffic cone placed on the outside edge of the traveled way. Draw one or more VIVDS detectors on the VIVDS monitor such that the entire length of the resulting detection zone is available to the VIVDS processor.

**Stop-Line Plus Advance Detection.** This section describes guidelines for determining an efficient detection zone layout when advance detection is needed. This type of detection is typically used to provide a safe phase termination for the high-speed through movements on an intersection approach. Stop-line detection is also included with the advance detection to provide efficient service to the queue during the initial portion of the phase.

Table 6 provides the recommended advance detection zone locations and extension settings for VIVDS applications for daylight conditions. Extensions on the two detection zones provide dilemma zone protection for a range of speeds from the design speed (85<sup>th</sup> percentile) at the high end as well as slower speeds including speed values likely to cause gap out. Interpolation between cell values is appropriate for distances or heights intermediate to the values listed. The recommended advance detection design requires a controller passage time of 1.0 s. These advance detection zone values have not been field-tested, so installers should carefully monitor the intersection following installation and setup to ensure safe operations.

**Table 6. Advance Detection Zone Layout for VIVDS Applications.**

Approach Speed Limit, mph	Distance to 1 <sup>st</sup> Det. Zone, ft <sup>a</sup>	Distance To 2 <sup>nd</sup> Det. Zone, ft <sup>a</sup>	Camera Height, ft									
			25	30	35	40	45	25	30	35	40	45
			Distance from SL to Pole, ft					Detector Extension, sec <sup>b</sup>				
50	400	260	150	100	50	0	0	0.0	0.0	0.0	0.0	0.0
								<b>0.0</b>	<b>0.0</b>	<b>0.0</b>	<b>0.0</b>	<b>0.0</b>
55	445	300	195	145	95	45	0	0.0	0.0	0.0	0.0	0.0
								<b>0.2</b>	<b>0.1</b>	<b>0.1</b>	<b>0.1</b>	<b>0.1</b>
60	485	330	235	185	135	85	35	0.1	0.1	0.1	0.1	0.1
								<b>0.3</b>	<b>0.2</b>	<b>0.2</b>	<b>0.2</b>	<b>0.1</b>
65	540	380	290	240	190	140	90	0.3	0.3	0.3	0.3	0.3
								<b>0.6</b>	<b>0.5</b>	<b>0.5</b>	<b>0.4</b>	<b>0.4</b>
70	600	430	350	300	250	200	150	0.5	0.5	0.5	0.5	0.5
								<b>1.0</b>	<b>1.0</b>	<b>1.0</b>	<b>1.0</b>	<b>1.0</b>

<sup>a</sup> Distances measured from the stop line (SL).

<sup>b</sup> Detector extensions in bold apply to downstream detector.

When used with advance detection, the stop-line detection zone layout should follow the guidelines described in the previous section, “Stop-Line Detection.” Specifically, [Table 5](#) provides the length of this zone.

One difference exists between the layout of the stop-line detection zone *with* advance detection and the layout of the stop-line zone *without* advance detection. When used with advance detection, the controller has a 1.0-s passage time that is required by the advance detection zones. When used without advance detection, a 0.0-s passage time is required. Because the 1.0-s passage time is required when the stop-line detection zone is used with advance detection, it is necessary to make a slight modification to the stop-line detection zone’s operation. Specifically, the detector channel serving the stop-line detection zone should have the “inhibit” feature (e.g., Special Detector Mode 4 in Eagle controllers) invoked. It is also appropriate to have 0.0 s set in the controller delay and extend timers in the stop-line detector channel. The inhibit feature disables the stop-line detection zone after the queue, waiting at the start of the phase, has been served. The advance detection zones should have a detector channel that is separate from that of the stop-line detection zone.

During the initial VIVDS setup, installers should measure the beginning and end of each advance detection zone with a distance wheel. [Table 10](#) provides the location of the beginning of the zones, and the end of each zone is 20 ft closer to the stop line. Installers should mark each edge with a traffic cone placed on the outside edge of the traveled way. They should then draw VIVDS detectors on the VIVDS monitor such that the entire length of the resulting detection zone is available to the VIVDS processor.

As a last step in the setup, installers should set the extension value on the second advance detection zone according to the value listed in [Table 5](#). This setting is part of the VIVDS programming and applies to all detectors that comprise the second detection zone. The delay and extend timers provided in the controller for each detector channel should be set at 0.0 s.



## *Detection at Night*

As noted earlier in this document, night detection by video occurs prematurely due to detection of the leading edge of the headlight “bloom” instead of the actual vehicle. TTI research findings indicate that detector activations precede the actual vehicle by as much as 400 ft at a 10:1 aspect ratio. The discrepancy improved somewhat by using a 4:1 aspect ratio, resulting in almost all detection activations occurring within 200 ft of the vehicle. The detection termination at night was also different with the most pronounced effect being greater dispersion of termination points compared to daytime. One possible solution that might reduce the nighttime detection activation error, if available as an option in the controller, would be a variable “Delay” setting. If available, the delay setting would be zero during daylight hours and non-zero during the night, but changing the setting by season would be a complicating factor. The TTI research did not investigate the impact of this change.

## *Detection Mode*

One benefit of a VIVDS is the large number of detection zones that can be used and the limitless ways in which they can be combined and configured to control the intersection. Both pulse mode and presence mode detectors are available, where the latter can have any desired length. In addition, VIVDS can detect by direction (i.e., directional detectors) so that they only detect vehicles traveling in the desired direction. Linking of detectors is also available through the use of Boolean functions (i.e., AND, OR). [Figure 7](#) illustrates the use of these features. The next section describes the detector labeled “delay” in this figure.

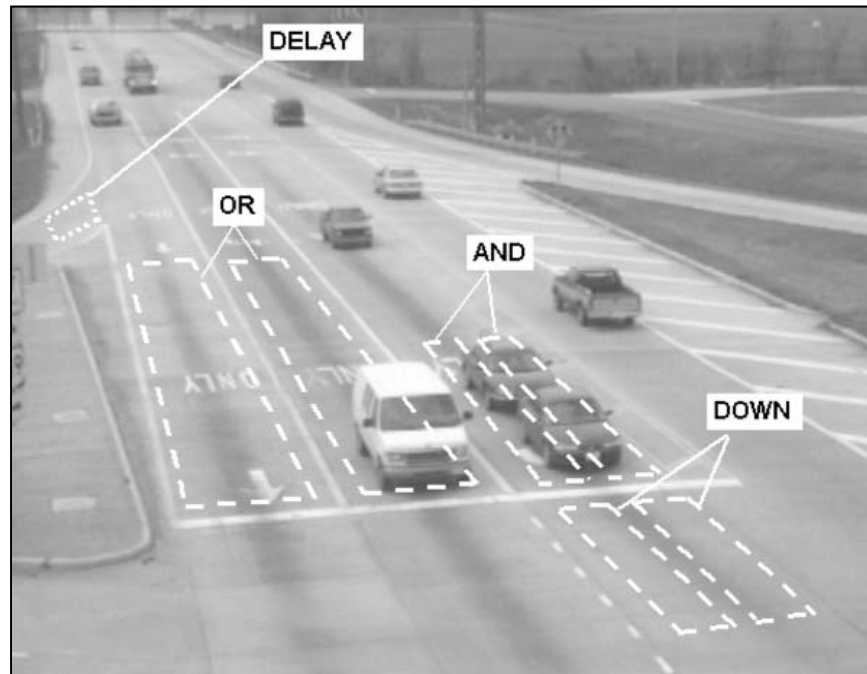

**Figure 7. Alternative Detection Modes.**

Figure 7 is an idealized illustration of alternative detection modes. The approach shown has presence-mode stop-line detection in each of the through and left-turn lanes. The zones in the two through lanes use an OR logic function, so detection of a vehicle in either lane will trigger a call to the through phase. This operation is identical to that achieved when both detectors are assigned to the same channel. However, the linkage allows for the specification of a common delay or extension time for both detectors.

The left-turn bay in Figure 7 uses two parallel detection zones for improved selectivity and sensitivity. Specifically, the right-side camera offset raises the possibility of an unneeded call from a tall vehicle in the adjacent through lane. The AND linkage for the two left-turn detection zones minimizes this problem. Also, for some VIVDS products, the use of two detectors in the same lane improves detection sensitivity.

Last, the Figure 7 intersection approach is skewed from 90 degrees, which results in a large distance between the stop line and the cross street. This setback distance is especially significant for the left-turn movements. In anticipation that left-turn drivers may creep past the stop line while waiting for a green indication, the setup uses additional detectors located beyond the stop line. However, they are directional detectors (as denoted by the word DOWN), such that they prevent crossing vehicles from triggering an unneeded call.

#### *Detector Settings*

Video detectors have delay and extend settings that can be used to screen calls or add time to their duration, as may be needed by the detection design. These settings are identical in performance and purpose to those available with inductive loop amplifiers. Figure 7 shows an application of delay setting. The detector in the right-turn lane serves as a queue detector to trigger a call to the through movement in the event that right-turning drivers cannot find adequate gaps in traffic. The delay is set to about 2 s, such that a turning vehicle does not trigger a call unless it is stopped in queue.

The delay setting is also available to reduce the frequency of unneeded calls. Specifically, agencies often set a few seconds of delay on the detectors in the stop-line detection zone of each minor-road approach. This setting offers two benefits. First, it eliminates false calls to the minor-road phases by major-road vehicle headlights (such as when a major-road vehicle makes a right turn and its headlights sweep across the minor-road stop-line detection zone). Second, it eliminates false calls to the minor-road phases by tall major-road vehicles (i.e., when tall vehicles cross the view of the minor-road camera and momentarily project their image onto the minor-road stop-line detection zones).

The delay setting is also available as an alternative to directional detectors. However, directional detectors, if available in the VIVDS being used, should be the solution of choice. If directional detectors function as intended, there should be no need to use a delay. This delay setting would screen unneeded calls for the left-turn phase caused by a tall through vehicle traveling away from the intersection.

## **On-Site Performance Checks**

### *Return Visit to Verify Operation*

In the days following the VIVDS installation, the engineer or technician should return to the intersection on one or more occasions and reevaluate the VIVDS performance. The purpose of each visit is to verify that the intersection is operating in an acceptable manner and that the VIVDS detectors are detecting vehicles with reasonable accuracy. In general, technicians should check operation and accuracy at midday, during the late afternoon, at night, and during early morning hours. If sun glare or reflection is a problem during the late afternoon or early morning, adjusting the visor on the camera housing might correct the problem. If this adjustment does not eliminate the problem, then increase the camera pitch angle.

### *Maintenance*

Field personnel should conduct a periodic check (approximately every six months) of the camera field-of-view and detection layout. During this check, the engineer or technician should:

- verify that the detection zones are still in the proper location relative to the traffic lanes,
- assess the impact of seasonal changes in the sun's position on detection accuracy,
- verify that the VIVDS is using the latest software version and upgrade it if needed, and
- check the camera lens for moisture or dirt buildup and clean if needed.

In areas with high humidity and extended concentrations of smoke, dust, or other airborne particles, the camera lens may need to be cleaned as frequently as every six weeks.



## REFERENCES

1. Bonneson, J., and M. Abbas. *Video Detection for Intersection and Interchange Control*. FHWA/TX-03/4285-1. Texas Transportation Institute, Texas A&M University System, College Station, Texas, September 2002.
2. Middleton, D., E.S. Park, R. Longmire, and H. Charara. *Improvements to Video Imaging Detection for Dilemma Zone Protection*. FHWA/TX-09/0-5774-1. Texas Transportation Institute, Texas A&M University System, College Station, Texas, February 2009.

