

Technical Report Documentation Page

1. Report No. FHWA/TX-09/0-5656-1		2. Government Accession No.		3. Recipient's Catalog No.	
4. Title and Subtitle SERVICEABLE PAVEMENT MARKING RETROREFLECTIVITY LEVELS: TECHNICAL REPORT				5. Report Date September 2008 Published: March 2009	
				6. Performing Organization Code	
7. Author(s) Robert J. Benz, Adam M. Pike, Shamanth P. Kuchangi and Quinn Brackett				8. Performing Organization Report No. Report 0-5656-1	
9. Performing Organization Name and Address Texas Transportation Institute The Texas A&M University System College Station, Texas 77843-3135				10. Work Unit No. (TRAIS)	
				11. Contract or Grant No. Project 0-5656	
12. Sponsoring Agency Name and Address Texas Department of Transportation Research and Technology Implementation Office P.O. Box 5080 Austin, Texas 78763-5080				13. Type of Report and Period Covered Technical Report: September 2006 - August 2008	
				14. Sponsoring Agency Code	
15. Supplementary Notes Project performed in cooperation with the Texas Department of Transportation and the Federal Highway Administration. Project Title: Serviceable Pavement Marking Retroreflectivity Levels URL: http://tti.tamu.edu/documents/0-5656-1.pdf					
16. Abstract This research addressed an array of issues related to measuring pavement markings retroreflectivity, factors related to pavement marking performance, subjective evaluation process, best practices for using mobile retroreflectometers, sampling pavement markings, and best practices for a Pavement Marking Management system. Tests conducted to assess subjective evaluation showed inconsistency in subjective retroreflectivity evaluation when compared between different evaluations, marking color, and retroreflectivity levels. Sensitivity testing on several factors that could potentially affect mobile retroreflectometer readings showed that distance from which the measurements are taken and position across the measurement window seemed to have the most significant impact on the mobile retroreflectivity measurements. The evaluation factors of data acquisition, vehicle speed, and small changes in measurement geometry made no practical difference to the measurement. However, constant speed provided best results. Based on the sensitivity testing this report enlists some best practices for mobile retroreflectometer measurements. A methodology for combining mobile retroreflectivity data with pavement information and plotting a map, color coded based on pavement marking retroreflectivity level using GIS, are demonstrated in this project. This report also provides discussion on other best practices for sampling and Pavement Marking Management system.					
17. Key Words Serviceable Pavement Marking, Pavement Marking Performance, Retroreflectivity, Pavement Marking Evaluation, Visual Inspection, Mobile Retroreflectometer, Sensitivity Testing, Calibration Best Practices, Pavement Marking Management System, Pavement Marking Information System, GIS, Sampling Methods			18. Distribution Statement No restrictions. This document is available to the public through NTIS: National Technical Information Service Springfield, Virginia 22161 http://www.ntis.gov		
19. Security Classif.(of this report) Unclassified		20. Security Classification (of this page) Unclassified		21. No. of Pages 150	22. Price

SERVICEABLE PAVEMENT MARKING RETROREFLECTIVITY LEVELS: TECHNICAL REPORT

by

Robert J. Benz, P.E.
Research Engineer
Texas Transportation Institute

Adam M. Pike
Associate Transportation Researcher
Texas Transportation Institute

Shamanth P. Kuchangi
Assistant Transportation Researcher
Texas Transportation Institute

and

Quinn Brackett
Senior Research Scientist
Texas Transportation Institute

Report 0-5656-1

Project 0-5656

Project Title: Serviceable Pavement Marking Retroreflectivity Levels

Performed in cooperation with the
Texas Department of Transportation
and the
Federal Highway Administration

September 2008

Published: March 2009

TEXAS TRANSPORTATION INSTITUTE
The Texas A&M University System
College Station, Texas 77843-3135

DISCLAIMER

This research was performed in cooperation with the Texas Department of Transportation (TxDOT) and the Federal Highway Administration (FHWA). The contents of this report reflect the views of the authors, who are responsible for the facts and the accuracy of the data presented herein. The contents do not necessarily reflect the official view or policies of the FHWA or TxDOT. This report does not constitute a standard, specification, or regulation. This report is not intended for construction, bidding, or permit purposes. The engineer in charge of the project was Robert J. Benz, P.E, #85382.

The United States Government and the State of Texas do not endorse products or manufacturers. Trade or manufacturers' names appear herein solely because they are considered essential to the object of this report.

ACKNOWLEDGMENTS

This project was conducted in cooperation with the Texas Department of Transportation and the U.S. Department of Transportation, Federal Highway Administration. The authors wish to acknowledge the following individuals, without whose insight and assistance the successful completion of the first portion of this research project would not have been possible:

- Mr. Richard Kirby, P.E., Texas Department of Transportation, Construction Division, Project Director;
- Mr. Carlos Ibarra, P.E., Texas Department of Transportation, Atlanta District, Project Advisor;
- Mr. Wally Shaw, Texas Department of Transportation, Houston District, Project Advisor;
- Mr. Wade Odell, P.E., Texas Department of Transportation, Research and Technology Implementation Office, Austin, Research Engineer;
- Mr. Roy Wright, P.E., Texas Department of Transportation, Abilene District, Director of Transportation Operations;
- Mr. James Keener, Texas Department of Transportation, Houston District, Traffic Engineering Division, Special Events Coordinator;
- Mr. John Bassett, P.E., Texas Department of Transportation, Austin, Construction Division; and
- Mr. Richardo Castaneda, P.E., Texas Department of Transportation, San Antonio District.

The authors would also like to acknowledge the assistance of Paul Carlson, Greg Davis, Gene Hawkins, Dillon Funkhouser, Eun Sug Park, and Derek Ladd of the Texas Transportation Institute (TTI) at various stages of the project.

TABLE OF CONTENTS

	Page
LIST OF FIGURES	ix
LIST OF TABLES	xi
CHAPTER 1. INTRODUCTION.....	1
1.0 BACKGROUND.....	1
1.0.1 Factors and Issues with Measurement.....	1
1.1 OVERVIEW.....	2
CHAPTER 2. METHODOLOGY	5
2.0 Task 1. State-of-Practice Review.....	5
2.1 Task 2. Subjective Retroreflectivity Rating Evaluation.....	5
2.2 Task 3. Mobile Measurements and Best Practices.....	6
2.3 Task 4. Pavement Marking Management System Best Practices.....	7
2.4 Task 5. Summary of Findings and Recommendations.....	7
CHAPTER 3. LITERATURE REVIEW.....	9
3.0 Pavement Marking Materials.....	9
3.0.1 Paints.....	10
3.0.2 Thermoplastic.....	11
3.0.3 Preformed Tape.....	11
3.0.4 Epoxy.....	12
3.0.5 Other Materials.....	12
3.0.6 Usage and Costs.....	12
3.1 Pavement Marking Usage.....	14
3.2 Pavement Marking Evaluation Techniques.....	14
3.2.1 Visual Inspections.....	14
3.2.2 Handheld Retroreflectometers.....	15
3.2.3 Mobile Retroreflectometers.....	16
3.3 Aspects of Pavement Marking Visibility.....	17
3.3.1 Retroreflectivity.....	17
3.3.2 Contrast Ratio.....	17
3.3.3 Measurement Geometry.....	18
3.4 Factors Affecting Retroreflectivity and Marking Visibility.....	19
3.4.1 Driver Age.....	20
3.4.2 Pavement Marking Contrast.....	21
3.4.3 Pavement Marking Beads.....	21
3.4.4 Retroreflective Raised Pavement Markers.....	22
3.4.5 Headlamp Illumination.....	22
3.4.6 Width of Marking.....	23
3.5 Pavement Marking Management Systems.....	23
3.6 Minimum Retroreflectivity of Traffic Signs.....	25
3.7 Minimum Retroreflectivity of Pavement Markings.....	26
3.8 Mobile Retroreflectometers.....	30
3.8.1 Technical Details of Mobile Retroreflectometers.....	31
3.8.2 Operational Details Reported on Mobile Retroreflectometers.....	32
3.8.3 Comparison Between Mobile and Handheld Retroreflectometers.....	32
3.8.4 Issues Reported with Mobile Retroreflectometers.....	34
CHAPTER 4. SUBJECTIVE RETROREFLECTIVITY RATING EVALUATION.....	37
4.0 Current Practices in Retroreflectivity Assessment.....	37

4.1 First Study on Subjective Retroreflectivity Rating Assessment	39
4.1.1 Subjective Retroreflectivity Test Procedure	40
4.1.2 Comparison of Subjective Ratings to Measured Mobile Readings	41
4.1.3 Comparison of Retroreflectivity Ratings by Pavement and Marking Characteristics	44
4.1.4 Individual Retro-Rating Analysis	45
4.1.5 Comparison of Rating Factors Used for the Test	48
4.2 Second Night Subjective Retroreflectivity Test.....	49
4.2.1 Test Procedure	49
4.2.2 Individual Retroreflectivity Assessment: Before-After Analysis	50
4.2.3 Before-After Analysis of Average Subjective Retroreflectivity	52
4.2.4 Subjective Retroreflectivity Assessment Trend by Pavement Marking Color	52
4.2.5 Discussion	56
4.3 Comparison of Handheld and Mobile Retroreflectometer Readings.....	56
CHAPTER 5. MOBILE MEASUREMENTS AND BEST PRACTICES	59
5.0 Sensitivity Analysis of Major Variables.....	59
5.0.1 Static Testing.....	60
5.0.2 Dynamic Testing	66
5.0.3 Combined Static and Dynamic Testing	72
5.0.4 Limitations to the Sensitivity Analysis of the Major Variables.....	80
5.1 Operational Best Practices.....	82
5.2 Developing a Decision Model for Managing Pavement Marking Replacement.....	83
5.2.1 Introduction	83
5.2.2 Objective	84
5.2.3 Method.....	85
5.2.4 Suggested Sampling Plan Methodology	86
5.2.5 Procedure.....	87
5.2.6 Analysis and Results.....	87
CHAPTER 6. PAVEMENT MARKING MANAGEMENT SYSTEM BEST PRACTICES	89
6.0 Introduction	89
6.1 Retroreflectivity Data File Headers	90
6.2 Prototype in Automation.....	91
6.3 GIS Procedures	92
6.3.1 Overview	93
6.3.2 What Is Needed	94
6.3.3 Retroreflectivity Data File Preparation.....	94
6.3.4 Adding Retroreflectivity Points to GIS	95
6.3.5 Locate Features Along a Route.....	99
CHAPTER 7. SUMMARY OF FINDINGS AND RECOMMENDATIONS.....	103
7.0 Findings	103
7.1 Recommendations.....	106
REFERENCES.....	109
APPENDIX A: NIGHT RETROREFLECTIVITY RATING FORM	A-1
APPENDIX B: DETAILED ANALYSIS OUTPUT	B-1
APPENDIX C: INDIVIDUAL RETRO-RATING GRAPHS	C-1
APPENDIX D: INDIVIDUAL RETROREFLECTIVITY ASSESSMENT BEFORE AND AFTER TRAINING	D-1

LIST OF FIGURES

	Page
Figure 1. Pavement Marking Retroreflection.	17
Figure 2. Standard 30-Meter Geometry for Retro Measurement (10).	18
Figure 3. Diagrammatic Representation of Laserlux Unit (10).	31
Figure 4. Correlation between Measured Retro Values and Subjective Retro-ratings.	42
Figure 5. Retroreflectivity Rating Trend.	43
Figure 6. Retro Rating by Pavement Color.	44
Figure 7. Contrast Rating by Pavement and Marking Color.	45
Figure 8. Individual Retro-ratings for Subject 1.	47
Figure 9. Individual Retro-ratings for Subject 7.	48
Figure 10. Average Rating of Different Factors Used in the Study.	49
Figure 11. Retroreflectivity Assessment Graph for Participant #5.	51
Figure 12. Retroreflectivity Assessment Graph for Participant #6.	51
Figure 13. Retroreflectivity Assessment Trend for Yellow Markings.	55
Figure 14. Retroreflectivity Assessment Trend for White Markings.	55
Figure 15. Comparison of Mobile and Handheld Retroreflectivity Measurements from Night Study 1.	58
Figure 16. Measurement Distance Testing.	62
Figure 17. Temperature Characterization Testing.	63
Figure 18. Temperature Compensation Testing.	64
Figure 19. Linearity Testing.	66
Figure 20. Right Side Static Position Testing.	74
Figure 21. Left Side Static Position Testing.	74
Figure 22. Visual of the Laser Pattern.	75
Figure 23. Dynamic Position Testing.	77
Figure 24. Nighttime Oncoming Vehicle Testing.	79
Figure 25. Predictive Retroreflectivity Model Based on Marking Age and Traffic Volume.	84
Figure 26. Prototype Menu Driven Retroreflectivity Data File Header Input Screen.	90
Figure 27. Flowchart Showing High Level of Automation.	92
Figure 28. Coordinate System Import Screen.	97
Figure 29. ArcView XY Data Screen.	98
Figure 30. Saving Layer Dialog Box.	99
Figure 31. Export of the Point File as a Layer.	99
Figure 32. Locate Features Along Routes Tool.	100
Figure 33. Importing Retro Route File.	101
Figure B-1. Comparison of Mobile Measurements with Human Judgment by Color Ratings.	B-3
Figure B-2. Comparison of Mobile Measurements with Human Judgment by Contrast Ratings.	B-3
Figure B-3. Comparison of Mobile Measurements with Human Judgment by Overall Quality Ratings.	B-4
Figure B-4. Pavement Marking Rating Trend Analysis by Average Color Ratings.	B-4
Figure B-5. Pavement Marking Rating Trend Analysis by Average Contrast Ratings.	B-5

LIST OF FIGURES (cont.)

	Page
Figure B-6. Pavement Marking Rating Trend Analysis by Overall Quality Ratings	B-5
Figure C-1. Individual Retro-Ratings for Subject 1.....	C-3
Figure C-2. Individual Retro-Ratings for Subject 2.....	C-3
Figure C-3. Individual Retro-Ratings for Subject 3.....	C-4
Figure C-4. Individual Retro-Ratings for Subject 4.....	C-4
Figure C-5. Individual Retro-Ratings for Subject 5.....	C-5
Figure C-6. Individual Retro-Ratings for Subject 6.....	C-5
Figure C-7. Individual Retro-Ratings for Subject 7.....	C-6
Figure C-8. Individual Retro-Ratings for Subject 8.....	C-6
Figure D-1. Retroreflectivity Assessment Graph for Participant 1.....	D-3
Figure D-2. Retroreflectivity Assessment Graph for Participant 2.....	D-3
Figure D-3. Retroreflectivity Assessment Graph for Participant 3.....	D-4
Figure D-4. Retroreflectivity Assessment Graph for Participant 4.....	D-4
Figure D-5. Retroreflectivity Assessment Graph for Participant 5.....	D-5
Figure D-6. Retroreflectivity Assessment Graph for Participant 6.....	D-5
Figure D-7. Retroreflectivity Assessment Graph for Participant 7.....	D-6
Figure D-8. Retroreflectivity Assessment Graph for Participant 8.....	D-6
Figure D-9. Retroreflectivity Assessment Graph for Participant 9.....	D-7
Figure D-10. Retroreflectivity Assessment Graph for Participant 10.....	D-7
Figure D-11. Retroreflectivity Assessment Graph for Participant 11.....	D-8

LIST OF TABLES

	Page
Table 1. Factors Affecting Pavement Marking Performance.	2
Table 2. Pavement Marking Material Types Used by Transportation Agencies (4).	10
Table 3. Pavement Marking Materials and Overall Usage (6).	13
Table 4. Pavement Marking Cost and Service Life (7).	13
Table 5. Factors Affecting Retroreflectivity in Pavement Markings (10).	20
Table 6. Illuminance on Pavement Marking by Headlight Type (13).	23
Table 7. Factors and Criteria Used in TARVIP Model.	29
Table 8. Minimum Retroreflectivity Values (in mcd/m ² /lux) Derived from TARVIP (38).	30
Table 9. Recommended Minimum Retroreflectivity Values (in mcd/m ² /lux) (38).	30
Table 10. Summary of TxDOT Districts' Pavement Marking Evaluation	39
Table 11. Test Pavement Marking Segments.	41
Table 12. Summary of Retroreflectivity Rating and Mobile Retroreflectivity Values for Each Segment.	42
Table 13. Difference between Individual Ratings and Average Retroreflectivity Rating.	46
Table 14. Difference between Individual Ratings and Mobile Retroreflectivity Values.	47
Table 15. Before-After Retroreflectivity Assessment Statistics for All Participants.	53
Table 16. Before-After Retroreflectivity Assessment Statistics for Experienced Participants. ..	53
Table 17. Before-After Retroreflectivity Assessment Statistics for Inexperienced Participants.	54
Table 18. Height Setup Testing.	61
Table 19. Acquisition Frequency Testing.	67
Table 20. Speed of Data Collection Testing.	68
Table 21. Individual Trials on Several Lines.	69
Table 22. Multiple Trials on Same Double Line.	70
Table 23. All Signal to Noise Ratio Trials.	72
Table 24. Signal to Noise Ratio Average Values.	72
Table 25. Dynamic Overhead Lighting Testing.	78
Table 26. Static Night Testing.	80
Table 27. Static/Dynamic Simulated Traffic Testing.	80
Table A-1. 0-5656 Project Demo and Night-Time Pavement Marking Evaluation	A-3

CHAPTER 1. INTRODUCTION

1.0 BACKGROUND

Crash statistics from the National Highway Traffic Safety Administration (NHTSA) have shown that fatal crashes are three to four times more likely to occur during nighttime than during daytime (*1*). The crash statistics show that about half of the almost 40,000 motor vehicle fatalities each year occur at night. Many preventable causes contribute to nighttime traffic crashes such as driving under the influence of drugs or alcohol, distracted driving, run off the road crashes, etc. Limited nighttime visibility is one cause of nighttime crashes. Improving the visibility of the roadway or the roadway path is a vital aspect that could possibly reduce the number of nighttime crashes. Overhead lighting, retroreflective signing, and retroreflective markings are ways that roadway delineation can be improved.

Major highways and city streets in urban areas commonly have overhead lighting. Using luminary poles and high-mast lighting can be very effective in lighting the road and the right of way in urban areas. Retroreflective signing and markings are common traffic control devices on all roads. Both overhead lighting and retroreflective pavement markings have been proven to improve the overall safety of the roadway.

In 1993, Congress issued a mandate to define minimum levels of retroreflectivity for signs and markings. While the minimum retroreflectivity rulemaking for signing has been established, pavement marking retroreflectivity rulemaking has yet to be established. Management of signs and pavement markings is essential as they are an important part of the roadway infrastructure. The useful life of a pavement markings ranges from less than 1 year up to 8 years and in some cases even longer. The lifespan of a marking is influenced by a variety of variables related to marking type and environmental conditions. Many new pavement marking materials are being developed for use on all pavement surfaces. The cost and performance of pavement markings and their relationship with driver safety and comfort make the research into their management vital.

1.0.1 Factors and Issues with Measurement

Several states have researched and developed Pavement Marking Management systems to improve the management of this vital asset. TxDOT has two programs for assessing pavement

marking condition on a statewide basis: Texas Maintenance Assessment Program (TxMAP) and Texas Traffic Assessment Program (TxTAP). Each program uses subjective judgments of a sample of markings in each district to represent the condition of markings throughout the district. Because pavement markings are only a small part of these assessment programs, the subjective ratings may not be entirely accurate in identifying roadways with poor markings. The subjective nature of these measurements can lead to varying or even contradictory results. Estimated retroreflectivity levels and the general marking condition are the measurers used to indicate pavement marking performance during these subjective assessments.

Actual quantitative measures of pavement marking performance variables are more desirable than qualitative assessments. Pavement marking width and lane line length are variables that can easily be measured. Color, contrast, and presence of the marking are also important variables but currently these variables are not quantitatively measured on a routine basis. Retroreflectivity is the major variable of a markings nighttime performance, but is not quantitatively measured as a standard practice. The costs and time associated with quantitative measurements has led many states to rely solely on subjective measures of pavement marking performance.

Pavement marking performance can be broken into two main categories: visibility factors and durability factors. [Table 1](#) lists some of the major factors for each category.

Table 1. Factors Affecting Pavement Marking Performance.

Visibility Factors	Durability Factors
Contrast	Marking Material
Retroreflectivity	Marking Thickness
Presence	Pavement Type
Pavement Texture	Pavement Texture
Pavement Color	Traffic Volume
Marking Color	Weather
Marking Type	Maintenance Activities
Marking Size	Marking Location (Edgeline, Centerline, Lane line)
Headlamp Type	Roadway Geometry (Horizontal Curves, Weaving Areas, etc.)
Viewing Geometry	
Ambient Lighting Conditions	

1.1 OVERVIEW

Good pavement markings are necessary for the traveling public’s safety. Effectively managing pavement markings is a difficult process. There are few quantitative procedures and requirements to determine adequacy or serviceability of pavement marking. Retroreflectivity is

the main measurement to determine adequate or serviceable pavement markings. Current qualitative evaluation procedures such as visual inspection are subjective in nature and may produce varying results. Current quantitative measurements using handheld retroreflectometers can be slow and costly. Mobile retroreflectometers have been developed in recent years to safely collect large amounts of retroreflective data quickly. Mobile retroreflectometers without proper calibration practices and improper measurement techniques can result in erroneous and inconsistent data, leading to distrust in a very useful tool among State DOTs.

In an effort to improve accuracy and confidence in the mobile data, TxDOT worked with TTI to establish the Mobile Retroreflectivity Certification Program. TxDOT then required certification for any contractor using a mobile retroreflectometer for retroreflectivity data collection. All TxDOT contractors must also meet all requirements in Special Specification 8094, which covers mobile retroreflectivity data collection for pavement markings (2). The basic concept of the certification program is to provide a quantitative basis for evaluating the ability of a contractor to accurately measure the retroreflectivity of long-line pavement markings. A contractor who desires to be certified sends the personnel and equipment to the TTI certification course. The closed course consists of numerous pavement markings of various colors, patterns, and retroreflectivity levels. The contractor is required to measure a selection of lines on the certification course and a selection of lines on open roads surrounding the facility. All the markings measured by the contractor with the mobile retroreflectometer are then measured by TTI using a handheld retroreflectometer to determine the official values of the markings. TTI compares the handheld measurements to the mobile measurement values and determines whether the mobile readings are within ± 15 percent, which is the maximum allowable difference for certification.

The certification program tests the ability of contractor's initial setup and calibration and their ability to properly use the mobile retroreflectometer to take measurements. However, the certification program is not able to take into consideration several variables that may change over the course of a day of measurements (e.g., change in temperature, ambient light conditions). Also most contractors getting the certification adopt their own unscientific and non-uniform methods to setup the mobile unit. Currently there is little "scientific" guidance or "uniform/best" procedures with TxDOT and/or contractors using mobile retroreflectometers such as:

- properly setting up and operating the mobile retroreflectometer,

- sampling the data, and
- interpreting the large quantity of data obtained from a mobile retroreflector.

Handheld retroreflectometers are simple to use on small pavement marking samples, easy to calibrate, and external factors have less influence on measurements taken with handled devices. As such, handheld retroreflectometers are fairly accurate and have been considered as a benchmark for retroreflectivity measurements. However, there has been no correlation with the data collected from handheld and mobile retroreflectometers and how the mobile retroreflector readings relate to visual evaluations. This has been a concern or inhibiting factor for TxDOT and other state DOTs to use mobile retroreflectometers.

This research focused on some of the above mentioned concerns with practical use of mobile retroreflectometers and pavement marking evaluation methods. The primary goals of this project were to address the following issues:

- adequacy of pavement marking performance characteristics;
- accuracy of existing pavement marking retroreflectivity measurement evaluation criteria (visual inspection);
- correlation between data from handheld and mobile retroreflectometers;
- best practices for calibrating and using mobile retroreflectivity devices, including a recommended sampling methodology; and
- best practices to handle a large amount of pavement marking data and manage pavement markings as a system.

CHAPTER 2. METHODOLOGY

This project focused on developing recommendations and best practices for mobile measurements, sampling methodology, and Pavement Marking Management systems. The project work was divided into five major tasks, within which there were several subtasks. This chapter provides a brief description of each of these major tasks.

2.0 TASK 1. STATE-OF-PRACTICE REVIEW

The researchers conducted a comprehensive literature search to identify publications on previous studies and existing practices related to pavement marking types, pavement marking retroreflectivity, retroreflectivity measurement techniques, minimum retroreflectivity values for pavement markings, and Pavement Marking Management. This search used all available bibliographic resources including the internet and various catalogs and databases such as Texas A&M University's Sterling C. Evans Library local library database, Online Computer Library Center database, National Technical Information System, and Transportation Research Information Service.

The researchers selected key words and word combinations to conduct a systematic search of these databases. After identifying potential literature sources, researchers acquired and reviewed those abstracts for applicability to the project. Those documents identified as being of interest were obtained for incorporation into the literature review. Some of the major factors affecting the pavement marking performance were identified from literature, and a brief discussion on those factors is provided. Background information on retroreflectivity and current available techniques for retroreflectivity assessment are briefed. Significant differences between handheld and mobile retroreflectometers as listed in various literature were compiled. Also minimum retroreflectivity research conducted throughout the nation and elsewhere identifies the range of minimum retroreflectivity value to lie between 80 to 150 mcd/m²/lux. Factors affecting minimum retroreflectivity values, such as driver age, pavement marking color, etc. were identified from literature. [Chapter 3](#) of this report provides more details on this effort.

2.1 TASK 2. SUBJECTIVE RETROREFLECTIVITY RATING EVALUATION

In this task researchers compared subjective retroreflectivity assessment with measured retroreflectivity values. The purpose of this task was to find how well the subjective evaluation

correlated with the actual measurements. This task involved two subtasks. First, researchers compiled the existing pavement marking retroreflectivity evaluation practices adopted by various districts in TxDOT. Almost all the districts primarily relied on subjective visual inspection for evaluating retroreflectivity, and some districts did indicate a concern over the consistency of visual evaluations. Only a couple of districts used quantitative measurements in addition to visual evaluation. A few of the districts were considering using mobile retroreflectometers for evaluation and wanted to see how it worked for districts that were currently using mobile retroreflectometers.

The second subtask involved comparing the subjective evaluation and measured retroreflectivity. This was achieved by conducting two night tests with participants from TxDOT and TTI. The first test was conducted entirely on open roads whereas the second test was conducted entirely on a closed experimental course set up. Researchers correlated the subjective rating with the actual retroreflectivity values. Also several trend analyses were conducted to see how well the subjective ratings followed the actual retroreflectivity trend. Researchers carried out trend analysis for different pavement marking colors, pavement type, etc. Retroreflectivity data were collected using both handheld and mobile retroreflectometers, which enabled researchers to compare measurements taken from handheld and mobile retroreflectometers. In the second night test, researchers tried to capture the effect of minimal training on subjective evaluation.

[Chapter 4](#) of this report presents the compilation of the current practices in pavement marking retroreflectivity assessment adopted by all 25 TxDOT districts. This chapter also provides details of the two night tests where subjective evaluation was compared with actual measured retroreflectivity values.

2.2 TASK 3. MOBILE MEASUREMENTS AND BEST PRACTICES

In this task researchers conducted a sensitivity testing of a mobile retroreflectometer. This sensitivity testing sought to quantify the effect of several factors on retroreflectivity measurements taken using mobile retroreflectometers. Some variables used to test the sensitivity of mobile retroreflectometers are:

- internal temperature,
- measurement geometry,

- lateral position,
- speed,
- ambient light, and
- signal to noise ratio.

This task involved controlled dynamic and static experiments using a Laserlux™ van-mounted mobile retroreflectometer. Discussion on major variables that affect mobile retroreflectivity measurements and the resulting calibration requirements, data collection methods, and data output requirements are documented as best practices.

This task also provides a proof of concept for sampling methodology to select roadways for retroreflectivity evaluation. [Chapter 5](#) of this report provides more details on the mobile measurement best practices and sampling methodology.

2.3 TASK 4. PAVEMENT MARKING MANAGEMENT SYSTEM BEST PRACTICES

TxDOT has many different databases that track a host of variables. These databases use a variety of referencing systems that can potentially be used to track, relate and manage different types of markings on different types of pavements, under different environmental and traffic conditions. Using these databases as one system provides TxDOT with the information to make informed decisions on past marking performance to predict future results. New technologies may also provide a means to improve pavement marking retroreflectivity measurement, along with a series of best measurement practices.

This task investigated the ability to link existing databases with pavement and markings information. Researchers also developed recommendations and prototypes on elements to include, data file setup, format, etc., that will be useful to automate the data aggregation and display. Processing techniques and methodology to display the retroreflectivity data on GIS maps and provide drill down detail allowing the user the ability to glance at a map to determine the conditions over an entire district to the detailed readings of a specific segment of roadway. [Chapter 6](#) of this report provides more detail on this task.

2.4 TASK 5. SUMMARY OF FINDINGS AND RECOMMENDATIONS

A comparison of handheld and mobile retroreflectometer readings showed a close correlation between the two sets of data. This indicates that mobile retroreflectometers, when

properly calibrated and used, can record accurate measurements. The subjective retroreflectivity analysis indicated that there was some correlation between visual evaluation and actual measurements, but the trend was not consistent. Minimal training provided to participants did not show any consistent improvement in their visual evaluations based on the small sample of test subjects.

The sensitivity analysis conducted on various factors influencing mobile retroreflectometers showed that some factors had greater influence on mobile retroreflector readings than others. Distance from which the measurements are taken and position across the measurement window seemed to have the most significant impact on the mobile retroreflectivity measurements. Of the evaluating factors data acquisition frequency, vehicle speed, and small changes in measurement geometry made no practical difference to the mobile measurements. Ambient lighting too did not have any significant impact on the mobile measurements. However, constant speed (without much acceleration/deceleration) was found to provide best results.

A fairly simple and useful approach to Pavement Marking Management System (PMMS) is described in this project. There were numerous benefits to linking the Pavement Management Information System (PMIS) database to the retroreflectivity readings such as deriving pavement marking degradation curve, visual Geographic Information Systems (GIS) maps of state of pavement markings, and reducing the processing time by automating these procedures.

[Chapter 7](#) provides a summary of the tasks completed and provides a detailed list on the major findings from each of the tasks. The chapter also provides recommendations for implementation and areas of further study.

CHAPTER 3. LITERATURE REVIEW

Nighttime visibility of traffic signs and pavement markings are necessary to delineate the roadway to provide guidance for drivers and safe operation of traffic. Signs and markings are valuable devices intended to improve motorists' safety and need to be maintained for maximum benefits where installed. Retroreflectivity, an important property of signs and pavement markings, allows motorists to more easily see these devices at night. In the early 1990s, Congress mandated that the Secretary of Transportation revise the Manual on Uniform Traffic Control Devices (MUTCD), published by the Federal Highway Administration (FHWA), to include minimum retroreflectivity standards that need to be maintained for all pavement marking and signs on public roads (3).

This chapter presents a brief review of some of the related topics concerned with retroreflectivity of pavement markings and minimum retroreflectivity standards for traffic control devices. This chapter starts with a brief introduction to various aspects related to pavement markings and their retroreflectivity, followed by a time-line presentation of the minimum retroreflectivity implementation efforts that traffic signs have undergone. The next section discusses some of the research efforts undertaken in establishing the minimum retroreflectivity for pavement markings. The final section reviews the effectiveness of mobile retroreflectometers in measuring the retroreflectivity of pavement markings and highlights some of the practical issues in the use of mobile retroreflectometers.

3.0 PAVEMENT MARKING MATERIALS

Many pavement marking materials are used around the country for various reasons. Table 2 provides a comprehensive list of pavement marking materials (4). The table also provides the total number of agencies that at the time were using a particular marking material and the percentage of agencies by category. Some of the commonly used pavement marking materials like waterborne paints, solvent paints, thermoplastic, tapes, and others are discussed in this section. Advantages and disadvantages of these pavement marking materials will also be discussed.

Table 2. Pavement Marking Material Types Used by Transportation Agencies (4).

Type of Markings	Transportation Agencies Reporting Using the Marking Material									
	Total		State		Canadian		Country		City	
	(51) ^a	% ^b	(37) ^a	% ^b	(5) ^a	% ^b	(5) ^a	% ^b	(4) ^a	% ^b
Longitudinal Markings										
Waterborne paints	40	78		89			5	100	2	50
Thermoplastic	35	69	33	81			3	60	2	50
Performed tape – flat	22	43	30	51			2	40	1	25
Performed tape – profiled	21	41	19	54					1	25
Epoxy	20	39	20	51			1	20		
Conventional solvent paint	20	39	19	35	5		1	20	1	25
Methyl methacrylate	10	20	13	24		100	1	20		
Thermoplastic – profiled	9	18	9	24						
Polyester	5	10	9	14						
Polyurea	2	4	5	5						
Cold applied plastic	1	2	2	3						
Experimental	1	2	1	3						
Green lite powder	1	2	1	3						
Polyester – profiled	1	2	1	3						
Tape (removable)	1	2	1	3						
HD-21	1	2	1				1	20		
Pavement Markers										
Raised retroreflective	16	31	14	38					2	50
Recessed retroreflective	4	8	4	11						
Snowplowable retroreflective	16	31	14	38			2	40		
Non-retroreflective	5	10	4	11					1	25

^aNumber of transportation agencies that responded to survey.

^bPercentage of the responding agencies reporting using the marking material.

3.0.1 Paints

One of the most widely used pavement marking materials is waterborne paint. Waterborne paints are the least expensive pavement marking material available and are environmental friendly, with less Volatile Organic Compound (less than the permissible limit of 150 g/L of VOC) and easily disposable. Conventional solvent paints, though more durable than waterborne paints, have high VOC content and have seen diminishing use after the introduction of new regulations by the Environmental Protection Agency (EPA). Another advantage of waterborne paints is that they can be applied with greater thickness when compared to solvent based paints. Waterborne paints are usually sprayed using a striping truck and the thickness of paint application can be varied using truck speed or outflow rate (5). Higher thickness of waterborne paints can hold larger glass beads which can be more efficient in terms of visibility (retroreflectivity) during wet-night conditions.

Waterborne paints perform similarly on asphalt and concrete pavements, but the durability of waterborne paints has been a common complaint of many state agencies. Waterborne paints wear off quickly and lose their retroreflectivity sooner than other pavement

marking materials when exposed to high traffic conditions. For the above reason, waterborne paints are typically used for temporary pavement markings or in areas with low traffic volumes, unless restriped at least annually. Also, due to the short service life of waterborne markings, several state agencies prefer to repaint the waterborne markings on a fixed schedule rather than restriping based on quantitative measures (4).

3.0.2 Thermoplastic

Thermoplastic is also another widely used pavement marking material due to its moderate cost and long durability. Glass beads form one of the components of thermoplastics along with binder, pigment, and other fillers. Thermoplastics are environmental friendly with low VOC content. Thermoplastics are applied using various methods like box or ribbon extrusion, or spray. TxDOT most commonly uses the spray applied thermoplastic (5). The majority of pavement markings in Texas are thermoplastic. Reapplication of thermoplastics over older thermoplastic pavement markings does not require the removal of the old marking.

Thermoplastics perform well on asphalt pavements, but not as well on concrete pavements. It is reported that many state agencies have discontinued the use of thermoplastic pavement markings on concrete pavements. Thermoplastics tend to crack away from concrete resulting in reduced retroreflectivity and durability of the marking.

3.0.3 Preformed Tape

Tape based pavement markings are factory manufactured with glass beads built into the tape. New tapes typically have a higher initial retroreflectivity than standard markings. Tapes are used in limited conditions due to their high cost, but many tapes come with a warranty on their performance. Tapes are typically used on concrete surfaces and in high traffic areas. There are two application methods for preformed tape, the inlaid and overlaid methods. The inlaid method is used on new roadway surfaces and is usually the preferred application. The overlaid method is used on preexisting road surfaces. In the case of overlaid tape, surface preparation and primers may be recommended for proper bonding (5). Tapes generally have a life span of four to eight years, and the life span differs based on the type of tape and roadway conditions. Proper application of tapes seems to have stringent requirements such as proper pavement and air temperature, curing time, use of quality adhesives, etc. However, many state

agencies feel that advantages of using tape in certain situations outweighs the application and cost requirements.

3.0.4 Epoxy

Epoxy paint is a durable pavement marking material that has good adhesion to both asphalt and concrete pavements. Epoxies are comprised of two components that are mixed on site during application. The first component of epoxy contains resin, pigment, extenders, and fillers, while the second component contains a catalyst to accelerate the setting and reduce drying time. Glass beads are sometimes premixed in the first component and are applied on top of the pavement marking stripes while still wet. Epoxy markings have moderate cost and an expected service life of two to four years. Though it is also noted in some studies that epoxy paints discolor with age when exposed to intense ultraviolet rays, many agencies prefer epoxy paints on concrete pavements with high traffic volumes due to its durability and cost. Epoxies are applied using special equipment, mounted on a truck where both components are mixed at a certain temperature, and sprayed onto the pavement (4).

3.0.5 Other Materials

Methyl methacrylate is another durable pavement marking, but its use has been very limited in United States except for Alaska. Methyl methacrylate has less stringent requirements for application compared to previously discussed materials, i.e., it can be applied in very cool conditions. This material bonds well with asphalt and concrete.

Polyurea is a newer pavement marking material claimed to be durable and effective on both asphalt and concrete pavements. This material has not been popular among most state agencies surveyed due to the need for special equipment required for application and higher cost compared to other materials.

3.0.6 Usage and Costs

The South Carolina Department of Transportation conducted a survey, where transportation agencies in all 50 states, including Puerto Rico and District of Columbia were asked their overall preferences for pavement marking materials, and their preference of interstate pavement marking materials. [Table 3](#) presents a summary of the responses from 29 participating agencies for the usage of various marking materials (6). The results from the survey concur with

the discussion provided on various pavement marking materials earlier in this section. Table 4 presents the cost and service life comparison of each of the above discussed pavement marking materials (7). The table provides the installation cost, service life, and life cycle cost of each marking type for white and yellow markings. It can be seen that waterborne paint has the least installation and life-cycle cost, but also lowest average service life. This lower service life will require more frequent restriping of the markings and should be considered for safety and logistical purposes. It should also be noted that though installation costs are the same for a marking material when compared between white and yellow markings, the life-cycle costs are different for white and yellow markings for the same marking material.

Table 3. Pavement Marking Materials and Overall Usage (6).

Marking Material	Overall	Interstate
Water-based paint	90%	38%
Solvent-based pain	38%	3%
Tape	66%	21%
Thermoplastic	76%	34%
Epoxy	55%	28%
Other	10%	10%

Table 4. Pavement Marking Cost and Service Life (7).

Material	Pavement Marking Installation Cost (\$/ft)		Pavement Marking Service Life (months)		Life-Cycle Cost to Provide Pavement Marking (\$/ft/yr)	
	Typical	Range	Typical	Range	Typical	Range
White						
Waterborne paint	0.06	0.02 – 0.20	10.4	3.1 – 17.7	0.07	0.01 – 0.76
Epoxy	0.26	0.08 – 0.65	23.0	5.9 – 40.1	0.14	0.02 – 1.33
Methyl methacrylate	1.22	0.70 – 1.53	14.4	6.8 – 22.0	1.02	0.38 – 2.70
Methyl methacrylate - profiled	1.44	1.12 – 1.75	21.0	7.6 – 34.3	0.82	0.39 – 2.76
Polyester	0.13	0.05 – 0.30	24.7	16.9 – 32.6	0.06	0.02 – 0.21
Preformed tape – profiled	2.33	1.50 – 3.10	27.4	13.8 – 41.0	1.02	0.44 – 2.70
Thermoplastic	0.32	0.08 – 0.85	26.2	12.1 – 40.3	0.14	0.02 – 0.84
Thermoplastic – profiled	0.87	0.35 – 1.30	23.8	11.1 – 36.6	0.44	0.11 – 1.41
Yellow						
Epoxy	0.26	0.08 – 0.65	34.3	19.8 – 48.9	0.09	0.02 – 0.39
Methyl methacrylate	1.22	0.70 – 1.53	16.8	12.6 – 21.0	0.87	0.40 – 1.46
Methyl methacrylate - profiled	1.44	1.12 – 1.75	25.0	19.1 – 31.0	0.69	0.43 – 1.10
Polyester	0.13	0.05 – 0.30	43.8	38.0 – 49.6	0.04	0.01 – 0.09
Preformed tape – profiled	2.33	1.50 – 3.10	30.6	18.7 – 42.5	0.91	0.42 – 1.99
Thermoplastic	0.32	0.08 – 0.85	27.5	15.4 – 39.5	0.14	0.02 – 0.66
Thermoplastic – profiled	0.87	0.35 – 1.30	26.7	16.4 – 37.0	0.39	0.11 – 0.95

3.1 PAVEMENT MARKING USAGE

Pavement marking usage can be broadly classified as how the markings are used (laid out) on the road. Possible marking uses would be longitudinal, transverse, symbols, words, and special markings. One major concern with degrading retroreflectivity of pavement markings arises in the case of longitudinal markings that are used for delineating the traffic in different directions or along the same direction. Poor visibility of longitudinal pavement markings can be a contributing factor in vehicular crashes.

Longitudinal pavement markings can be further classified as centerline markings, edgeline markings, and lane line markings. Centerline markings are used to separate traffic flowing in opposing directions and are always yellow in color. Centerline markings can be either a lane line (also called skip or broken lines) or a double line with a combination of broken and solid lines. Edgelines are solid yellow or solid white line and are used to mark the edge of the travel lane. Lane lines are used to mark lanes along a single direction when multiple lanes exist. Lane lines are always white in color and are typically a broken line unless passing is not permitted. Also white dotted lane lines are sometimes used in merging areas to delineate merging lanes (8).

3.2 PAVEMENT MARKING EVALUATION TECHNIQUES

The following discussion provides the pros and cons on various pavement marking evaluation techniques.

3.2.1 Visual Inspections

Visual inspection is a subjective technique used to evaluate the quality of a marking. The goal of the inspection is to make sure that the marking is providing adequate retroreflectivity and presence. Pavement Marking Management systems typically involve both daytime and nighttime visual inspections. Pavement markings are more adequately evaluated with a visual inspection at night versus the day because the ability of the marking to retroreflect light can be seen by how much of the headlamp light is reflected back toward the vehicle. Even at night though, the evaluation is still subjective and the quality of the marking will differ depending on the opinion of the observer. Visual inspections are usually recommended on a yearly basis (5).

Visual inspections have several advantages such as:

- simple and fast,
- low cost,
- no special equipment, and
- very little impact on traffic while conducting the inspection.

The downside of visual inspection is that it is subjective in nature, and results may vary widely from one evaluator to another. Also visual inspection results may vary depending on the contrast between pavement marking and the pavement. For example, two white-colored pavement markings having the same retroreflectivity values, one on a concrete pavement and the other on an asphalt pavement, could be perceived differently by the evaluator. The pavement marking on darker pavement could be perceived as *brighter* than the pavement marking on the lighter pavement. Thus, visual inspections are prone to human error, are hard to verify for correctness, and therefore are not the most reliable technique to produce consistent results.

3.2.2 Handheld Retroreflectometers

Handheld retroreflectometers provide one means of obtaining a quantitative measure of pavement marking retroreflectivity. A handheld retroreflectometer is a small unit that is manually placed and moved along a line while collecting retroreflectivity readings. Handheld retroreflectometers can normally be operated by a single person, but additional crew would be required if a lane closure is necessary or for watching for traffic if a lane closure is not provided (6).

Advantages of handheld retroreflectometers are:

- simple calibration process,
- operation requires little training,
- consistent and reliable data collection, and
- less expensive to purchase and maintain compared to mobile retroreflectometers.

Disadvantages of handheld retroreflectometers are:

- may require lane closures to take measurements (especially for lane lines,
- may lead to unsafe situations as the operator is exposed to traffic,
- fewer samples can be collected in a given time, and
- measuring long lengths of pavement markings can be time consuming and costly.

3.2.3 Mobile Retroreflectometers

Mobile retroreflectometer provide another means of obtaining a quantitative measure of pavement marking retroreflectivity. Mobile retroreflectometers are mounted to the side of a vehicle and collect retroreflectivity as the vehicle drives down the road. An operator inside the vehicle controls the retroreflectometer and monitors the data collection via the connected computer software. Mobile retroreflectometers themselves are about four times as expensive as a handheld retroreflectometer, but this does not include the cost of the necessary computer system or vehicle to use. Mobile retroreflectometers also require more training and maintenance than handheld retroreflectometers. Mobile retroreflectivity training is necessary if high quality data are to be collected.

Mobile retroreflectometers do have several advantages over handheld retroreflectometers. Mobile retroreflectometers can measure much larger samples over a much longer length of road in a quicker amount of time than by just using a handheld retroreflectometer. The large quantity of data that mobile units can capture make them an effective tool in developing programs like a Pavement Marking Management system. Because the mobile retroreflectometer can be mounted on a vehicle, mobile retroreflectivity data collection does very little to disrupt traffic while taking measurements, and lane closures are not required. Mobile retroreflectometers typically require a two person team to collect data, one for driving the instrumented vehicle and the other for operating the software. Since the data collection team will be inside the vehicle for the most part, there are fewer safety concerns in operating mobile retroreflectometers as compared to handheld retroreflectometers. Mobile retroreflectometers are sensitive to several factors that have much less impact on handheld retroreflectometers thus the need for proper training. Factors such as environmental conditions, measurement geometry, calibration procedures, software operation, and driving precision all can effect the quality of the data.

3.3 ASPECTS OF PAVEMENT MARKING VISIBILITY

Retroreflectivity, contrast between pavement marking and the road surface, and viewing angle (measurement geometry) are some of the important aspects for good visibility of pavement marking. This section provides a brief description of each of the above aspects.

3.3.1 Retroreflectivity

Retroreflectivity is a property of a material where incident light is reflected back towards its source. Retroreflectivity makes a material appear bright when light illuminates it. The higher the retroreflectivity of a material, the higher the percentage of light reflected back to the source and the brighter the material appears.

Coefficient of retroreflected luminance (R_L) is the most common measure used to describe the retroreflectivity of pavement markings. Coefficient of retroreflected luminance is typically expressed in units of $\text{mcd}/\text{m}^2/\text{lux}$. Retroreflectometers are able to measure retroreflectivity by illuminating a marking with a known amount of light and measuring how much of that light is returned to the unit. [Figure 1](#) shows how glass beads embedded in a pavement marking material retroreflect light.

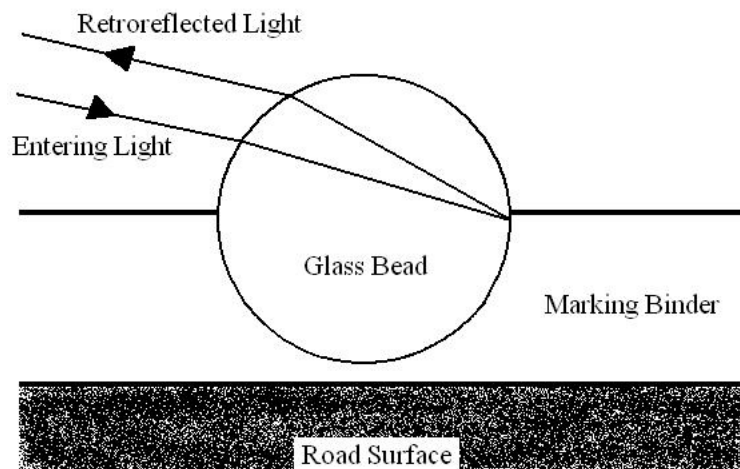

Figure 1. Pavement Marking Retroreflection.

3.3.2 Contrast Ratio

Contrast between the pavement marking and the road surface is an important factor for visibility of pavement markings. Daytime contrast is a comparison of the color contrast between the marking and the road surface. The nighttime contrast ratio (CR) is relationship between the

retroreflectivity of the pavement marking as compared to that of the surrounding road surface (see the following equation) (6).

$$CR = \frac{(R_{L(\text{Marking})} - R_{L(\text{Pavement Surface})})}{R_{L(\text{Pavement Surface})}}$$

3.3.3 Measurement Geometry

The currently accepted geometry for measuring pavement marking retroreflectivity is a 30-meter geometry. As shown in Figure 2, the 30-meter geometry has an observation angle of 1.05 degrees and an entrance angle of 88.76 degrees (co-entrance angle of 1.24 degrees). European Committee for Normalization (CEN) initially set the standard 30-meter geometry, and it is described in ASTM E 1710 (9). Prior to the early 90s, studies measuring retroreflectivity have been found to use various geometries, such as 12 or 15-meter. Since a change in geometry results in significant change in the readings, measurements made using different geometries are not precisely comparable. However with the establishment of the 30-meter geometry standard, a more consistent comparison of measurements will be possible. Such a standard is also necessary in order to establish minimum retroreflectivity values for pavement markings.

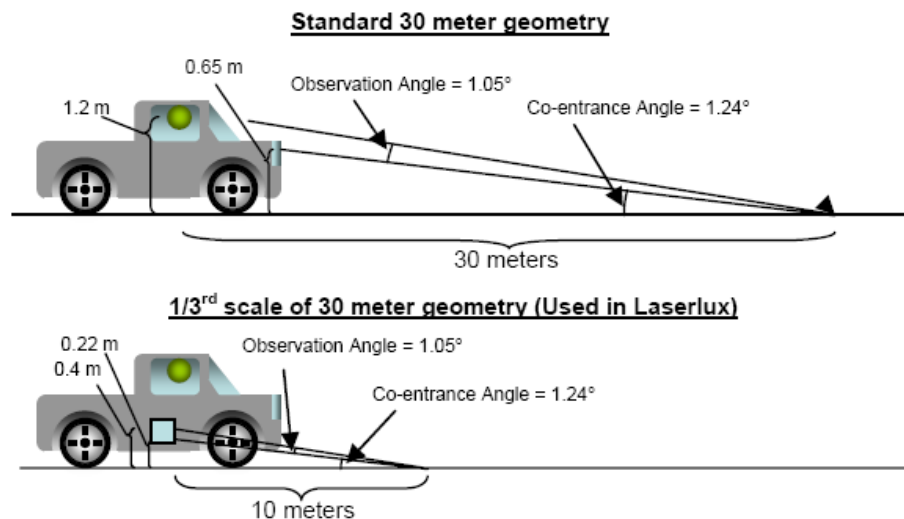

Figure 2. Standard 30-Meter Geometry for Retro Measurement (10).

Retroreflectometers, both handheld and mobile, use a scaled version of the 30-meter geometry. The reduced scale is compliant with the 30-meter standards, in terms of maintaining all the required angles, but typically performs measurements at a distance much shorter than

30-meters. Mobile units for instance measure at a distance of 10 meters, and handheld units generally measure within one meter. Retroreflectometer manufacturers adopted a reduced scale for practical reasons and for the fact that there would be less interference to the incident and reflected light when taking field measurements with the reduced scale (10).

3.4 FACTORS AFFECTING RETROREFLECTIVITY AND MARKING VISIBILITY

This section provided discussion on some factors that affect pavement marking visibility. These factors need to be accounted for when assessing the retroreflectivity and retroreflectivity requirements of pavement markings. Some of the other factors that have been reported to influence pavement marking visibility but are not discussed are:

- pavement wear,
- pavement marking presence,
- centerline configuration,
- lateral separation between double lines,
- retroreflective area in the pavement marking,
- windshield transmission,
- driver workload,
- weather conditions, and
- traffic volume.

For a given marking, retroreflectivity depends on the number of beads present, composition of the beads, surface condition of the beads, embedment depth of the beads, and binder material used. Pavement markings typically have their highest retroreflectivity shortly after they are applied and excess beads have been removed by traffic, assuming proper marking application. In some cases markings degrade extremely fast if beads were not embedded enough, because traffic quickly dislodges the beads. In other cases the beads may be over embedded causing a low initial retroreflectivity that may increase as the beads become more exposed. Typically retroreflectivity decreases over time for several reasons; the following are several examples:

- glass beads get dislodged due to traffic,
- degradation of binder due to oxidation and ultraviolet sunlight resulting in bead loss,

- changes in pavement marking color due to fading pigments,
- brittleness of binders can result in detachment of binders along with glass beads from the pavement surface,
- snowplowing can also result in significant loss or scraping of glass beads and can also result in binder detachment, and
- markings become dirty and rain is not sufficient to clean them.

Not all pavement marking retroreflectivity decreases at the same rate or even in the same manner. Some markings may exhibit a linear degradation in retroreflectivity, while others may exhibit more of an exponentially decreasing retroreflectivity. [Table 5](#) presents the components of pavement markings, the factors of these components that influence retroreflectivity, and the resulting effect of those characteristics ([10](#)).

Table 5. Factors Affecting Retroreflectivity in Pavement Markings ([10](#)).

Factor	Characteristic of Factor	Factor Effects
Glass Beads	Amount and Dispersion	Amount: bead surface area for retroreflectance Dispersion: scattering of reflection between beads
	Embedment Depth	Surface area available for retroreflectance, adhesion to binder material
	Refractive Index	Amount of light directed to reflecting binder surface
	Size	Surface area for retroreflection, wet weather performance
	Clarity	Diffusion of light within the bead
	Roundness	Direction of retroreflection
Binding Material	Color	White typically reflects more than yellow
	Type	Some materials are more durable and reflective than others
	Thickness	Marking longevity
Other Factors	Wet Markings	Refractive index is changed and specula reflection is increased, reducing retroreflectivity
	Pavement Surface Roughness	Material adhesion and shadowing of beads in the valleys
	Dirt or Other Obscuring Material	Any object obscuring the light hitting the marking will reduce retroreflectivity
	Type of Retroreflectometer Used for Measurement	Ability to reproduce measurements varies between instruments

3.4.1 Driver Age

With an increase in age, the human eye needs more illumination to view an object due to a thickening and yellowing of the cornea. Therefore older drivers need a more retroreflective

marking in order to see a pavement marking from the same distance as a younger driver. Consequently, the age of a driver influences marking visibility and minimum retroreflectivity requirements to provide an adequate pavement marking.

Several studies have considered driver age in arriving at minimum retroreflectivity values; many are described in [Section 3.7](#). A study by the Virginia Transportation Research Center (VTRC) distinguished age groups above 65 and below 65 years. The VTRC report concludes that subjects above 65 years were generally unsatisfied with pavement marking brightness that was acceptable to subjects below 65 years ([11](#)).

3.4.2 Pavement Marking Contrast

A pavement marking evaluation study for the Minnesota Department of Transportation reported that there was not a good correlation between the public perception of pavement markings and measured retroreflectivity. One of the missing components cited in the study for not obtaining a good correlation was contrast. Contrast between the roadway surface and the pavement marking plays a significant role in the visibility of pavement markings. The study found that pavement markings on a dark bituminous pavement surface were rated consistently as very good or excellent by the subjects even though the retroreflectivity of the lines did not justify this high rating ([12](#)).

3.4.3 Pavement Marking Beads

Glass beads are an important component that provides retroreflective properties to pavement markings. Several factors related to glass beads influence the retroreflectivity of pavement markings and the longevity of the retroreflectivity. Some of these include bead size, bead properties, mixture of beads, quantity of beads, bead coatings, and embedment depth.

In pavement marking applications smaller beads tend to be easier to install and are less likely to encounter bead loss than larger bead applications. Larger beads are often recommended though because they are more likely to perform well in wet conditions and can provide higher retroreflectivity levels when properly installed. A double drop system of a mixture of large and small beads provides benefits of both bead types. Optimal bead embedment depth ranges from 55 to 60 percent of bead diameter ([13](#)). Bead properties like refraction index (RI), bead shape (roundness), and surface characteristics influence the retroreflective ability of beads embedded in

the pavement markings. Usually round beads with smooth surface are found to have a better retroreflective property than of other bead shape and surface characteristics. The optimal RI in dry conditions is approximately 1.9 and higher than that for wet conditions. Some wet reflective beads are in the 2.4 to 2.5 RI range.

3.4.4 Retroreflective Raised Pavement Markers

Retroreflective raised pavement markers (RRPMs) are highly retroreflective markers that are used to supplement normal pavement markings. Studies conducted to determine minimum retroreflectivity of pavement markings have found that with use of adequate RRPMs (at least three in view), the necessary pavement marking retroreflectivity is less than if no RRPMs are present (*14, 15, 16*). TTI research also found that new RRPMs have an average end detection distance of over 200 ft more than the next best pavement marking material studied under rainy conditions (*17*).

3.4.5 Headlamp Illumination

The position of the driver and headlamps influences the viewing geometry of pavement markings. Height of the headlamps above the pavement surface affects the entrance angle. Vertical separation between the headlamp and the driver's eye position affects the observation angle. The height of the driver's eye above the pavement surface determines the projected marking area visible to the driver. In a study conducted by the Virginia Tech Transportation Institute, pavement marking detection distances were increased by as much as 50 percent when viewed from semi truck verses a sedan (*18*). A study by the University of Michigan also reported a 19 percent increase in the pavement marking detection distance when the distance between the headlamp and drivers height was increased from 0.6 m to 1.2 m (*19*). Taken together, these studies show that truck drivers should have better visibility than car drivers.

A study using Exact Road Geometry Output software has reported the differences in illumination with use of different headlamps. [Table 6](#) presents the reported results (*13*). From the table it can be seen that newer headlamps have higher illuminance compared to the older headlamps. Drivers using newer headlamps would most likely have better visibility of pavement markings compared to those using older headlights with lower illuminance. This is due to a higher illuminance of the newer headlamps, resulting in a more light being reflected back.

Table 6. Illuminance on Pavement Marking by Headlight Type (13).

Headlamp	Illuminance on Pavement Marking (lux)							
	Edgeline				Centerline			
	30 m	60 m	100 m	150 m	30 m	60 m	100 m	150 m
2A1	43.47	5.87	1.427	0.507	5.867	1.148	0.512	0.265
CARTS50	33.74	6.6	1.488	0.481	6.199	1.185	0.434	0.198
UMTRI 1997	40.15	9.447	2.333	0.741	11.3	1.989	0.614	0.278
UMTRI 2004	33.49	10.36	3.391	1.324	16.3	3.884	1.493	0.703

*Lane width = 12ft

3.4.6 Width of Marking

The width of the pavement marking has been found to be a factor that may influence the visibility distance and minimum required retroreflectivity. Research is somewhat inconclusive but studies have found that with wider pavement markings, preview time is reduced, and the minimum required retroreflectivity is decreased. A study conducted by Lundkvist et al. showed that there is a consistent increase in visibility distance when a 6-inch wide marking is used instead of a 4-inch wide markings for speeds ranging from 40 to 70 mph (20). Another study reported by Gibbons indicates that wider pavement markings results in increased visibility distance, however the report also claims that at some critical width, that has yet to be determined, the benefits of increased visibility is limited (21). A review by Debaillon et al. pointed to several studies that experimented with wider pavement markings, indicating inconclusive results on the benefits of wider pavement markings (14).

3.5 PAVEMENT MARKING MANAGEMENT SYSTEMS

A Pavement Marking Management system is an advanced method of maintaining and monitoring pavement markings. A PMMS can take many forms from a basic system that only monitors a few aspects of the markings to a comprehensive system that monitors everything possible. Several states have begun using a PMMS in an attempt to improve their marking systems and reduce expenditures on pavement markings (7, 22, 23, 24, 25, 26, 27, 28). A PMMS may be necessary when minimum maintained retroreflectivity levels of pavement markings are implemented.

The main goal of a PMMS is to improve decision making with regards to pavement markings. Using the PMMS, decision makers can prioritize the restriping of roads, the best

products to put on certain roadway classifications, and anticipate future marking expenditures. These decisions are aided by the data input into the PMMS. Typical inputs into the systems are as follows (7, 22, 25):

- installation information,
 - location and quantity,
 - date,
 - marking binder type,
 - marking bead type,
 - contractor,
 - cost,
- traffic volumes,
- retroreflectivity data, and
- visual assessment (presence).

The installation information and periodic updates to the retroreflectivity data are the main components of the PMMS. Using this information, degradation curves can be created to determine an expected life of the marking and to determine when a marking is no longer adequate. Retroreflectivity data can be gathered either by handheld or mobile measurements. Handheld measurements will not provide as much data as mobile measurements but can be used if mobile data are not available. When large quantities of data are needed or data are needed on high volume roads, a mobile system will likely be the most effective means of retroreflectivity data collection. A nighttime visual assessment of the markings may also be used if actual measurements of retroreflectivity are not available. A nighttime visual assessment would be considered the minimum information needed to determine the markings nighttime effectiveness.

Missouri has already seen positive effects from their PMMS (22, 26). They have been able to monitor different products and track the retroreflectivity degradation and life span. This has led to improved striping policy and the reduction in the amount of times certain roads are striped, saving money. The safety implication of maintaining all markings to an acceptable level has not been documented, but ensures that all markings meet a minimum maintained retroreflectivity level will be necessary when the final rule is implemented.

3.6 MINIMUM RETROREFLECTIVITY OF TRAFFIC SIGNS

Following the congressional mandate to implement minimum retroreflectivity levels, there has been considerable progress in research as well as implementation of minimum retroreflectivity standards for traffic signs. This section documents the timeline of progress in the path to implementation of minimum retroreflectivity for traffic signs. Carlson and Hawkins have documented more details on the significant research results that were carried out regarding minimum retroreflectivity for traffic signs prior to the Congressional mandate and post mandate (29). A summary of the timeline for the implementation of minimum retroreflectivity for signs is as follows (30).

1984	Center for Auto Safety petition FHWA to established reflectivity standards for traffic signs and pavement markings.
1993	Congressional mandate to revise MUTCD to include minimum retroreflectivity standards for signs and markings.
1993-1998	Initial research on minimum retroreflectivity for traffic signs.
1998-2000	AASHTO task force review issues on presenting minimum retroreflectivity values in MUTCD and agency liability issues.
2001-2003	Updated research on overhead and street name signs. New headlamps accommodated in research. More workshops conducted.
2004	Rule proposed (NPA) to include in MUTCD, methods to maintain minimum retroreflectivity for traffic signs.
2004-2005	Comments solicited for the proposed rule (about 350 comments received from state agencies, transportation organizations, and individuals).
2006	Supplemental rule proposed (SNPA) based on the comments to include in MUTCD, minimum retroreflectivity values and the methods to maintain retroreflectivity above the minimum values.
2006	Comments solicited for SNPA till November 2006 (received 121 letters containing approximately 550 individual comments).
2008	January 22, 2008, final rule effective.

A glimpse at the above timeline shows the length of time that passed for the rule on minimum retroreflectivity for traffic signs. This gives an estimate of the possible time the pavement marking minimum retroreflectivity might take to be implemented.

3.7 MINIMUM RETROREFLECTIVITY OF PAVEMENT MARKINGS

Traffic signs have now complied with Congress's mandate on minimum retroreflectivity levels, but pavement markings are just now in the initial stages of addressing this mandate. The slower progress for pavement markings is likely due to the inherent difficulty in designing appropriate experiments to determine minimum retroreflectivity and the variables that influence marking visibility. Many of the early research studies that were carried out regarding retroreflectivity of pavement markings were difficult to adopt due to varied geometry that was used in measuring retroreflectivity. However, standardization in measurement geometry by ASTM has provided a standard platform to assess pavement marking retroreflectivity. Several studies over the last couple decades have looked at minimum retroreflectivity levels ([12](#), [21](#), [29](#), [31](#), [32](#), [33](#), [34](#), [35](#), [36](#), [37](#), [38](#)), and several of these studies are discussed below.

Zwahlen and Schnell conducted some of the early research to determine the minimum retroreflectivity with standard 30-meter geometry ([33](#)). The FHWA funded development of a computer model, Computer-Aided Road-Marking Visibility Evaluator (CARVE), to determine visibility requirements. In 2000, a study was reported to determine the minimum in-service retroreflectivity using an improvised CARVE model ([34](#)). The CARVE model in this study uses 30-meter geometry, with an observation angle of 1.05 and entrance angle of 88.7. The study focused on determining the minimum retroreflectivity of pavement markings with and without RRPMs. This study was conducted for two headlight types with two representative age groups: 22 years and 62 years old. The improvised CARVE model used in this study used a preview distance of 3.65 seconds for sections without RRPMs and 2.0 seconds for sections with RRPMs. Minimum retroreflectivity values for all scenarios of different headlight types, age groups, and presence of RRPMs were presented as a function of speed, ranging from 25 mph to 75 mph. The study by Zwahlen and Schnell recommends a minimum retroreflectivity of 340 mcd/m²/lux for white edgelines and about 260 mcd/m²/lux for yellow lines ([34](#)).

A 2002 study sponsored by the New Jersey Department of Transportation evaluated the state's 3-year fixed time restriping strategy to see if it was consistent with the actual service life

of the pavement markings (35). Two kinds of data were collected for this study. Retroreflective data for pavement markings were collected on approximately 600 line miles on south New Jersey highways using a mobile Laserlux retroreflectometer. The New Jersey driving public collected the second, subjective visibility data by driving on a 32 mile road circuit at night. An interviewer who drove along with the subject asked questions on the brightness and visibility of the pavement markings. There were 72 subjects involved in this study with equal proportion of male and females. The study indicated that there was no significant variation on the rating between genders.

The study also looked into the ratings by age group. The study found a significant difference in visual rating for the three different age groups, less than 35 years, 35-55 years, and greater than 55 years. Older groups had a lower average rating when compared to younger groups. A strong correlation was found between measured retroreflectivity and night time visibility ratings. The study concluded that a minimum retroreflectivity threshold for restriping was found to be between 80-125 mcd/m²/lux. Anything below 70 mcd/m²/lux was unacceptable by all age groups for all types of pavement markings. However, yellow pavement markings had the highest minimum retroreflectivity rated value. Raters above 55 years required retroreflectivity of at least 165 mcd/m²/lux for yellow centerlines and 160 mcd/m²/lux for lane lines.

An experimental study conducted on an expressway in Korea published in 2006 evaluated driver satisfaction with markings of various retroreflectivity levels (36). Road marking tapes 15 centimeters (5.9 inches) wide of white and yellow colors were installed on a 7.7 kilometer (4.8 miles) long section of test bed, which consisted of both concrete and asphalt surfaces. The retroreflectivity of the installed tapes ranged from 40-200 mcd/m²/lux. There were 49 participants in the study with twice as many males as females, and one third of the participants were above the age of 50. Dynamic tests were conducted to see how well the pavement markings were detected. Static tests were conducted to grade the brightness of the road marking tapes. Based on the test results, retroreflectivity values greater than 134 mcd/m²/lux for white markings and 104 mcd/m²/lux for yellow markings were found to be satisfactory by 90 percent of the participants (36).

Because older drivers have diminished visual acuity, they are critical in determining the minimum retroreflectivity for night driving. There has been an increase in the percentage of

older drivers in United States. Studies have reported that a 62 year old represents the 85th percentile licensed drivers and about 95th percentile of night time driver population (34, 35). With the increasing age of the driving population there is an emphasis on research results with minimum retroreflectivity values where older drivers are involved.

The University of North Carolina reported a study to determine the minimum retroreflectivity specifically for older drivers (37). Data were collected from 65 subjects, of which 30 were males and 35 females. Average age of the drivers was 62.2 years. This study reports that 85 percent of the drivers felt that 100 mcd/m²/lux or more was adequate. In this study an adjustment factor of 1.21 was derived to compensate for reduced retroreflectivity due to unclean headlight and windshield conditions. Considering the adjustment factor, 121 mcd/m²/lux was suggested as the minimum retroreflectivity value for any roadway marking (37). However, in this study there was no distinction made based on marking color or type (broken or continuous). Also this study did not consider weather conditions, such as dry or wet weather in determining the minimum retroreflectivity.

Most of the research on minimum retroreflectivity of pavement markings seems to range from 70-150 mcd/m²/lux. Factors, such as traffic speed, lighting, and age of driver, influence the minimum retroreflectivity values that drivers require for adequate visibility. Also to be considered is the pavement marking color, the presence of RRPMS, and wet weather conditions.

Updates to the earlier recommended minimum levels for pavement marking retroreflectivity were reported in 2007 (38). Earlier recommended values were based on the CARVE computer model, while the updated recommendation of minimum pavement marking retroreflectivity is based on the Target Visibility Predictor (TARVIP) model. The Operator Performance Laboratory group at The University of Ohio developed the TARVIP model. TARVIP has several advancements compared to the CARVE model. Some of the new factors included in the TARVIP model that were of importance to the updated minimum retroreflectivity recommendations were: (38)

- pavement marking configuration,
- pavement surface type,
- vehicle speed,
- vehicle type (headlights), and
- presence of RRPMS.

The TARVIP model was calibrated with updated and latest available datasets of the above mentioned factors to ensure the most accurate minimum retroreflectivity values were derived. For establishing the minimum pavement marking retroreflectivity, specific criteria were used in the TARVIP model. [Table 7](#) summarizes these criteria.

Table 7. Factors and Criteria Used in TARVIP Model.

Factor	Criteria
Pavement surface type	Old concrete and old asphalt were used
Pavement marking configurations	Following three configurations were used: * Single white dashed line to left of vehicle * Single yellow dashed line to left of vehicle * Single yellow dashed line to left of vehicle with a solid white edgeline to right
Vehicle types	Two vehicle types with dimension of: * 1998 Chevrolet Lumina * 1986 Freightliner
Operating speeds	* 40 MPH * 55 MPH * 70 MPH
Roadway lighting	Dark roadway used
Pavement marking materials	Alkyd paint and beads
Vehicle headlamp	2004 UMTRI 50 th percentile market weighted
Preview time	2.2 seconds
Driver age	62 years
RRPMs	Absent and present, both scenarios considered

[Table 8](#) presents the minimum pavement marking retroreflectivity values derived for all combinations of the above mentioned criteria. The study showed that fully marked roads had much lower requirements in terms of minimum retroreflectivity. Vehicles with higher eye position of the driver from the ground level, and lower speeds required lower values of required minimum retroreflectivity. As a recommendation for minimum levels of pavement marking retroreflectivity, the study put forth a table of minimum retroreflectivity values based on roadway marking configuration, travel speed, and presence of RRPMs. [Table 9](#) presents the recommended values.

Table 8. Minimum Retroreflectivity Values (in mcd/m²/lux) Derived from TARVIP (38).

RRPM Scenario	Marking Configuration	Pavement Surface	Vehicle Speed [km/h] ([mi/h])	Vehicle Type	
				Sedan	Freightliner
None (2.20s Preview Time)	YCL-WEL	Asphalt	64.4 (40)	32	37
			88.5 (55)	52	56
			112.7 (70)	92	86
		Concrete	64.4 (40)	26	30
			88.5 (55)	47	47
			112.7 (70)	88	79
	WLL	Asphalt	64.4 (40)	88	86
			88.5 (55)	223	188
			112.7 (70)	492	379
		Concrete	64.4 (40)	81	77
			88.5 (55)	215	176
			112.7 (70)	491	363
	YCL	Asphalt	64.4 (40)	94	83
			88.5 (55)	249	189
			112.7 (70)	577	391
Concrete		64.4 (40)	87	75	
		88.5 (55)	241	176	
		112.7 (70)	575	374	
Present and in good working order (at least 3 in view)	YCL-WEL	Asphalt	N/A	25	35
		Concrete	N/A	19	29
	WLL	Asphalt	N/A	40	55
		Concrete	N/A	33	48
	YCL	Asphalt	N/A	39	49
		Concrete	N/A	32	43

Table 9. Recommended Minimum Retroreflectivity Values (in mcd/m²/lux) (38).

Roadway Marking Configuration	Without RRPMs			With RRPMs
	≤ 50 mi/h	55-65 mi/h	≥ 70 mi/h	
Fully marked roadways (with centerline, lane lines and/or edgeline, as needed)	40	60	90	40
Roadways with centerlines only	90	250	575	50

*Applies to both yellow and white pavement markings.

3.8 MOBILE RETROREFLECTOMETERS

Mobile retroreflectometers are of practical importance for implementation of minimum retroreflectivity standards for pavement markings and for effective Pavement Marking Management systems. Mobile retroreflectometers take constant retroreflective readings while driving down the road, and thus are able to obtain a greater sample size of the pavement markings measured than can be obtained using a handheld retroreflectometer in a given span of

time. The mobile retroreflectometer as compared to a handheld retroreflectometer allows for more readings on more roads in a safer mobile environment.

3.8.1 Technical Details of Mobile Retroreflectometers

The Laserlux™ is the most common form of mobile retroreflectometer. The Laserlux uses a scanning laser unit, and the retroreflected laser light is received by optical sensors and processed to obtain information on the retroreflectivity value (39). Figure 3 shows a diagrammatic representation of the internals of a Laserlux mobile retroreflectometer. Another mobile unit is the Ecodyn mobile retroreflectometer. The Ecodyn uses a metallic iodide lamp and a set of lenses to emit light beams, and an electronic system with amplifiers and filters are used to detect retroreflected light (40). An evaluation study claims Ecodyn can acquire data at every 0.4 meter intervals irrespective of speed. It is also claimed that Ecodyn requires less calibration as it not necessary to calibrate differently for white and yellow markings, an advantage over the Laserlux (40). However, since Ecodyn machines are rarely used in the United States, no significant studies report on its performance characteristics or usage. Therefore, all the references of mobile retroreflectometers later in this report will refer to the Laserlux device, unless specifically mentioned otherwise.

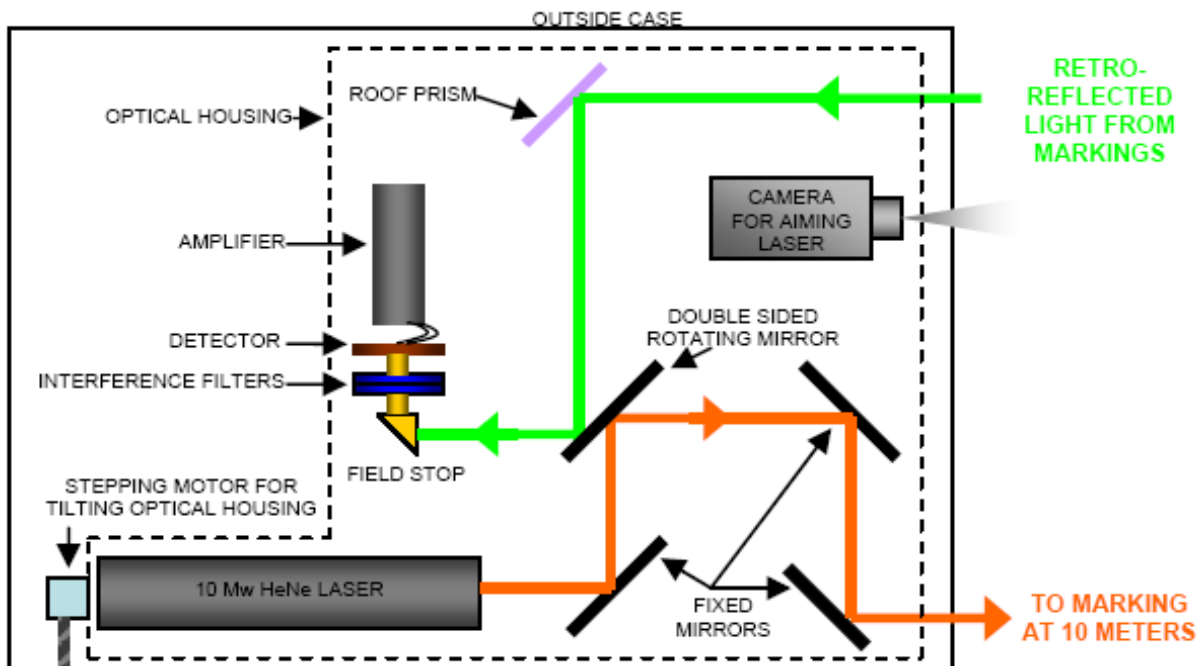

Figure 3. Diagrammatic Representation of Laserlux Unit (10).

3.8.2 Operational Details Reported on Mobile Retroreflectometers

Studies using the Laserlux have found several advantages over visual evaluation or handheld systems. A study conducted by Florida Department of Transportation (10, 41) on Mobile Retroreflectivity Testing for a Pavement Marking Management System reported that the Laserlux can collect more than 1000 data points per mile in less than a minute with 18-20 scans per second. In each scan the laser has capability of scanning a width of 1.1 m, and in each scan 200 discrete measurements can be obtained with about 25 of those measurements on the pavement marking itself (assuming a 4-inch wide marking). The scan width of the Laserlux can accommodate some wandering in vehicle movement. Operationally, use of mobile retroreflectometers can provide a safer environment for operating staff when compared to handheld retroreflectometers, since mobile retroreflectometers do not require personnel outside the vehicle during data collection. Also, the use of mobile units does not induce delay to motorists at the surveying site, and can avoid lane closures, especially when measuring center and lane lines (41).

3.8.3 Comparison Between Mobile and Handheld Retroreflectometers

Many agencies currently only conduct minimal handheld retroreflectivity data collection if they collect any at all. With the increasing need to monitor retroreflectivity, plans to use mobile retroreflectometers have been increasing. In this section, comparisons between mobile retroreflectometers and handheld retroreflectometers have been provided.

Handheld retroreflectometers had exclusively been used to measure pavement marking retroreflectivity prior to the introduction of the mobile device. As a result of longer and more frequent use, handheld retroreflectometers have standards for measurement and are inherently easier to calibrate and conduct measurements, resulting in more accurate readings than mobile retroreflectometers. In testing, good comparisons between handheld and mobile retroreflectivity data have been found. Several studies have compared retroreflectivity data gathered by handheld and mobile retroreflectometers (35, 42, 43, 44). The findings from these studies indicate that retroreflectivity values within 20 percent can be expected when comparing handheld and mobile values assuming both retroreflectometers are properly calibrated. With a better understanding of variables that may affect the mobile readings, the difference between handheld and mobile values can consistently be less than 20 percent. In practice though, users often find it difficult to

obtain consistent and accurate results using mobile retroreflectometers (35, 45). This is because there is very little guidance on standard practices for calibration and the operation of mobile retroreflectometers.

Handheld retroreflectometers are relatively easy to operate and need very little training prior to use. Mobile retroreflectometers are sensitive to various factors and need skillful technicians to accurately calibrate and operate the instrument for accurate measurements. On the downside, due to lack of sufficient guidance on calibration of mobile units, many agencies and personnel feel that mobile retroreflectometers are less accurate when compared to handheld retroreflectometers. Experience, proper calibration, and following proper techniques can result in data that are accurate and consistent. Actual comparisons between handheld and mobile data are documented as part of this study in [Section 4.3](#).

In terms of safety, mobile retroreflectometers are found to be safer to operate than handheld retroreflectometers. As mentioned previously, since mobile retroreflectometers do not require any personnel to be on the road during measurement, there is much less of a safety threat to the staff collecting the data. Depending on the calibration protocol and accuracy checks, mobile values may be compared to handheld measurements on similar lines which would require the data collectors to be on the road for a short time. These checks though can be conducted on lower volume roads reducing the threat of interaction with traffic. Also, since mobile data collection does not require stopping to take measurements along the road way, it is unlikely that vehicular collisions would occur due to retroreflectivity measurement in progress. This is especially an advantage when taking retroreflectivity measurements on high speed or high volume roadways.

Handheld retroreflectometers need very little time to setup the instrument for taking readings, compared to the calibration requirements for mobile retroreflectometers. On the other hand, operationally, mobile retroreflectometers are much more time efficient and can cover longer stretches of pavement markings than handheld retroreflectometers. While handheld retroreflectometers need to be stationary to take measurements, mobile retroreflectometers are able to take measurements traveling at highway speeds.

The cost of a handheld retroreflectometer is less initially and over time when compared to a mobile retroreflectometer. Handheld retroreflectometers are approximately in the range of \$12,000 to \$25,000 per unit depending on the model, while mobile retroreflectometers can

roughly cost \$80,000 for the retroreflectometer itself and up to \$200,000 for the entire package necessary to conduct mobile retroreflectivity data collection (mobile retroreflectometer, van, computer system, and other accessories). Mobile retroreflectometers require more maintenance than handheld retroreflectometers to make sure that everything is working properly due to the additional moving parts and being in the harsh environment of measuring off the side of a vehicle throwing things out of alignment. Though owning and operating mobile retroreflectometers is more expensive, the increased productivity and safety will likely offset these costs (43).

3.8.4 Issues Reported with Mobile Retroreflectometers

Although mobile retroreflectometers have many advantages, there have been some calibration related concerns with the use of mobile retroreflectometers (46). These concerns are a major issue because if the data provided by mobile retroreflectometers are not accurate then any advantage they have will not matter. A study conducted by Washington State Transportation Research Center reported variability in measurements across the lanes sections with similar AADT and variation in measurements when repeated over the same section of pavement marking on the same day (45). Some studies have also made effort to quantify the variation in measurements.

Repeatability and reproducibility are two measures of variation in retroreflectivity measurements. Repeatability refers to the ability of a mobile retroreflectometer to produce consistent reading when conditions of measurement are not changed. Reproducibility is the ability of different mobile retroreflectometers to produce consistent readings when measuring the same markings. A manufacturer at a Canadian facility conducted a repeatability testing using a Laserlux found a 5 percent variance over three runs (47). Tests conducted by the FHWA with three Laserlux instruments found repeatability to be within a 10 percent variation (48). Another evaluation study conducted by Highway Innovative Technology Evaluation Center (HITEC) reported variations due to specific conditions in temperature and humidity. Tests conducted by HITEC in an environmental chamber have shown to have reproducibility with a variation of about 25 percent. In the repeatability tests, maximum variation of about 8 percent was reported under high temperature and high humidity conditions for mobile retroreflectometers (39).

The variation in measurement with mobile retroreflectometers can to some extent be attributed to the inherent variation of the pavement marking material and sample size. It should also be noted that a significant amount of variation in mobile retroreflectivity reading can be attributed to the sensitivity of mobile retroreflectometers to various conditions. Some possible reasons for variation in mobile retroreflectivity data are listed below (10, 41, 44, 45, 46, 49):

- conditions at time of calibration may not reflect true field conditions,
- poor calibration standards and procedures,
- misalignment of mobile retroreflectometers internal parts,
- oscillation of the laser scan,
- improperly set thresholds during calibration and operation,
- sensitivity of the mobile retroreflectometer to internal temperature,
- background measurement noise,
- number of samples collected for averaging,
- ambient lighting at night and clouds or sun during the day,
- speed of data collection,
- difficulty measuring low retroreflectivity markings,
- measurement position across the laser scan,
- vehicle dynamics, and
- roadway geometry affecting measurement geometry.

Although some of the studies that have used mobile retroreflectometers have put forth possible reasons for the variations observed in the measurements, little effort has been made in quantifying the effect of some of the stated reasons for variation. The University of North Florida and the Florida Department of Transportation have conducted extensive research into the temperature sensitivity of the Laserlux retroreflectometer (49). Testing determined that the likely cause of the temperature sensitivity was in the optical filters that the Laserlux uses to filter out ambient light. Two sets of filters were tested, and each set experienced a different effect from the temperature increase. When one set was heated from 20°C to 40°C, the retroreflectivity continuously increased as the temperature increase, resulting in a 30 percent increase in retroreflectivity. The second set showed an increase and then a decrease in retroreflectivity as the temperature increased. The results of this testing prompted the manufacturer to include a

user adjustable algorithm in the software to help compensate for the effects of temperature change. When using the algorithm, the temperature sensitivity was reduced to ± 5 percent over the 20°C range. Another way to compensate for temperature changes is to install a thermostat controlled thermoelectric cooler on the mobile retroreflectometer to keep it at a relatively constant temperature. Continued testing of variables that may impact mobile retroreflectivity is needed to improve the accuracy and repeatability of mobile retroreflectivity data collection. This research will attempt to address many of the possible sources of variation to see their effects and possible ways to avoid any impact that they may have.

CHAPTER 4. SUBJECTIVE RETROREFLECTIVITY RATING EVALUATION

Traditionally, most districts within TxDOT subjectively evaluate pavement markings to recommend if the pavement marking retroreflectivity level is adequate or if it needs to be restriped. These subjective evaluations of pavement markings have several short comings; some of them are:

- bias based on the evaluators experience, training, and visual capabilities;
- less than systematic management of pavement markings;
- inconsistent and unrepeatable results; and
- potentially, inefficient allocation of funds for restriping.

However, the bias introduced in the subjective rating of pavement markings has not been quantified for TxDOT to get an estimate of the extent of induced bias in subjective evaluation. Quantifying any potential biases caused by using subjective ratings could be useful in improving the subjective evaluation through training, which would lead to more effective fund allocation.

This chapter provides some insights on the accuracy of subjective retroreflectivity evaluation. The first section summarizes the current practice of pavement marking retroreflectivity evaluation adopted by all the 25 TxDOT districts. The second section provides a quantitative assessment of subjective evaluation as obtained from the first night retroreflectivity testing. The third section provides further insights on subjective evaluation as obtained from a second night study, specifically the effect of minimal training on subjective evaluations. A final section provides a quantitative comparison of handheld and mobile retroreflectometer readings taken at several pavement marking sections.

4.0 CURRENT PRACTICES IN RETROREFLECTIVITY ASSESSMENT

Researchers conducted a phone survey to identify the current practices in pavement marking retroreflectivity assessment in all the 25 TxDOT districts. Operations and/or maintenance staff in each TxDOT district were contacted and the following information was sought:

- assessment methods used for pavement marking retroreflectivity,
- frequency of assessment,

- if they possess a handheld or mobile retroreflector, and
- pavement marking restriping practices.

Table 10 summarizes information obtained from all the districts. Almost all the districts primarily relied on visual inspection for pavement marking retroreflectivity assessment. The frequency of assessment was typically one to two assessments per year. Eleven out of 25 districts indicated that they had a bi-annual visual inspection program in place, while three districts indicated that they had yearly assessment program. The rest of the districts visually inspected the pavement markings on an as-needed basis or whenever they received public complaints. Some of the districts that had yearly or bi-yearly assessment program indicated that in addition to their scheduled assessment, they also performed visual assessments on an as-needed basis.

Two districts indicated the recent use of a mobile retroreflector to assess the pavement markings in conjunction with visual inspection. Both the Abilene and Atlanta districts indicated that they had a contract for collection of the mobile retroreflectivity data on their roads. The Beaumont district indicated that they were considering a contract for mobile retroreflectivity assessment, but were waiting to see the results of mobile retroreflectivity assessments from other districts. Two districts have had contracts with mobile retroreflectivity contractors for warranty pavement markings (Houston and San Antonio). Only the Abilene district indicated a regular use of a handheld retroreflector in conjunction with visual inspections.

Several districts are using warranty pavement markings, and provisions are made in those warranties to measure the retroreflectivity on a periodic basis. Some districts use mobile retroreflectometers to measure warranty markings, initial retroreflectivity readings, and after visual inspection and/or public complaint. The use of mobile retroreflectivity readings is expected to increase as initial retroreflectivity readings are being required.

Austin was the only district that indicated use of TxTAP information to assess their pavement markings in conjunction with visual inspections. Table 10 also indicates the information obtained on pavement marking restriping practices adopted by some districts.

Table 10. Summary of TxDOT Districts' Pavement Marking Evaluation and Restriping Practices.

TxDOT Districts	Pavement Marking Evaluation Methods			Pavement Marking Re-Striping Practice
	Visual Inspection	Handheld Retroreflectometer	Mobile Retroreflectometer	
Abilene	Yearly and as needed	Yes	Recent contract	
Amarillo	6 months			
Atlanta	6 months		Recent contract	
Austin	6 months			
Beaumont	As Needed		Considering a contract	
Brownwood	6 months			
Bryan	Yearly			Maintenance contract
Childress	Cyclic basis			
Corpus Christie	6 months			Maintenance contract
Dallas	6 months			Maintenance contract
El Paso	Yes	Yes		
Ft Worth	6 months			
Houston	As Needed		Contract in the past	Thermoplastic changed every 6 months and Tape changed every 3 years
Laredo	6 months (day & night inspection)			Maintenance contract
Lubbock	Yearly on thermo and polyurea			
Lufkin	As Needed			
Odessa	6 months			Maintenance contract
Paris	Yearly and as needed			Restriping job done each year
Pharr				Maintenance contract
San Angelo	Yearly (day & night inspection)			Markings replaced on cyclic basis
San Antonio				Performance based contract
Tyler	6 months			
Waco	As Needed			Maintenance contract
Wichita Falls	Along with sign inspection			Markings replaced on cyclic basis
Yoakum	6 months and as needed			

4.1 FIRST STUDY ON SUBJECTIVE RETROREFLECTIVITY RATING ASSESSMENT

This section provides the results of a study that was conducted to evaluate the subjective ratings against measured retroreflectivity at several test segments. The following are the objectives of the analysis:

- compare handheld and mobile retroreflectometer readings,

- compare subjective ratings and measured retroreflectivity readings,
- conduct a trend analysis of subjective ratings by pavement and marking characteristics, and
- check for consistency in subjective rating and determine factors that could affect subjective ratings.

4.1.1 Subjective Retroreflectivity Test Procedure

Researchers conducted a subjective retroreflectivity assessment test to determine how the members of this research project subjectively rate pavement marking lines as compared to the measured retroreflectivity. The group that participated in this study consisted of eight people with different experience levels in assessing pavement marking retroreflectivity.

The test was conducted between 9:00 PM and 10:30 PM on a pre-selected route in the Bryan/College Station area. Before the start of the test, the group was briefed about the test procedure and the test questionnaire was explained. A sample test questionnaire is attached in [Appendix A](#) of this memorandum. The evaluating group was driven in three separate cars along the test course, with each car following at a long enough distance to ensure that the headlights of one car do not influence the visibility of the evaluators in the car ahead.

The course consisted of 16 sample locations ranging from a tenth of a mile to half of a mile in length. The sample pavement markings for the test consisted of edgelines, centerlines, and lane lines with a mix of white and yellow color markings on several pavement types such as concrete, asphalt, and seal coat. Researchers had measured all the test sites with handheld and mobile retroreflectometers prior to the subjective evaluations, but the measured values were not informed to the evaluators. [Table 11](#) lists all the sites evaluated in this test.

The groups were informed of the upcoming test segment as they were driven along the test course and were asked rate the pavement marking segment for the following characteristics:

- marking color,
- marking contrast with the surrounding pavement,
- marking retroreflectivity, and
- overall condition of the marking.

The test pavement marking segments were rated for the four factors listed above on a scale from 1 to 5, with 1 being poor and 5 being excellent. The raters were also asked to provide additional comments on the test segments.

Table 11. Test Pavement Marking Segments.

Segment #	Road Segment	Line Type	Marking Color	Pavement Type
1	SH 47 N	Edgeline	White	Light Asphalt
2	SH 21 W	Edgeline	White	Light Seal Coat
3	SH 21 W Bridge	Edgeline	White	Concrete
4	FM 50 S	Edgeline	White	Dark Seal Coat
5	FM 50 S	Center	Yellow	Dark Seal Coat
6	FM 50 S	Edgeline	White	Dark Seal Coat
7	SH 60 E	Edgeline	White	Light Seal Coat
8	Victoria	Center	Yellow	Concrete
9	Graham	Edgeline	White	Concrete
10	Victoria	Edgeline	White	Concrete
11	SH 40 SE	Edgeline	White	Asphalt
12	SH 40 SE	Center	Yellow	Asphalt
13	SH 40 SE	Center	Yellow	Asphalt
14	WD Fitch E	Lane Lines	White	Concrete
15	WD Fitch E	Edgeline	White	Concrete
16	SH 6 West	Edgeline	White	Dark Seal Coat

4.1.2 Comparison of Subjective Ratings to Measured Mobile Readings

Researchers conducted an analysis to assess how closely human judgment correlates with the quantitative retroreflectivity measurements. Researchers compared the mobile retroreflectivity measurements with the subjective ratings of the evaluated characteristics.

Table 12 provides a summary of the mobile retroreflectivity values and the average retroreflectivity ratings for each segment. Figure 4 shows the correlation with an R^2 value of 0.74 between mobile retroreflectivity measurements and subjective retroreflectivity ratings. A linear relationship explains about 74 percent of the variation in the mobile measurements between measured retroreflectivity values and subjective retroreflectivity ratings. As it can be seen from Figure 4, there is less scattering around the retro trend line for retroreflectivity values below $300 \text{ mcd/m}^2/\text{lux}$. However, the scattering is greater for retro values above $300 \text{ mcd/m}^2/\text{lux}$. Correlation analysis of measured retroreflectivity values with color, contrast, and overall quality resulted in similar correlations, 0.77, 0.71, and 0.68, respectively.

Appendix B presents the graphs of the correlation analysis for color, contrast and overall quality.

Table 12. Summary of Retroreflectivity Rating and Mobile Retroreflectivity Values for Each Segment.

Segment #	Pavement type	Line Location	Average: Retro Rating	Std Dev: Retro Rating	Mobile Retro Values(mcd/m ² /lux)
1	Light asphalt	Edgeline	3.50	1.844	298
2	Light Seal Coat	Edgeline	3.38	1.867	357
3	Concrete	Edgeline	3.25	1.803	366
4	Dark Seal Coat	Edgeline	3.00	1.633	230
5	Dark Seal Coat	Center	2.13	1.144	125
6	Dark Seal Coat	Edgeline	2.88	1.625	169
7	Light Seal Coat	Edgeline	1.63	1.312	121
8	Concrete	Center	1.94	1.183	93
9	Concrete	Edgeline	1.25	0.776	88
10	Concrete	Edgeline	3.63	1.966	282
11	Asphalt	Edgeline	3.75	1.998	235
12	Asphalt	Center	3.88	2.041	419
13	Asphalt	Center (sect 2)	2.38	1.495	119
14	Concrete	Lane Lines	3.13	1.714	332
15	Concrete	Edgeline	2.50	1.335	202
16	Dark Seal Coat	Edgeline	3.50	1.844	315

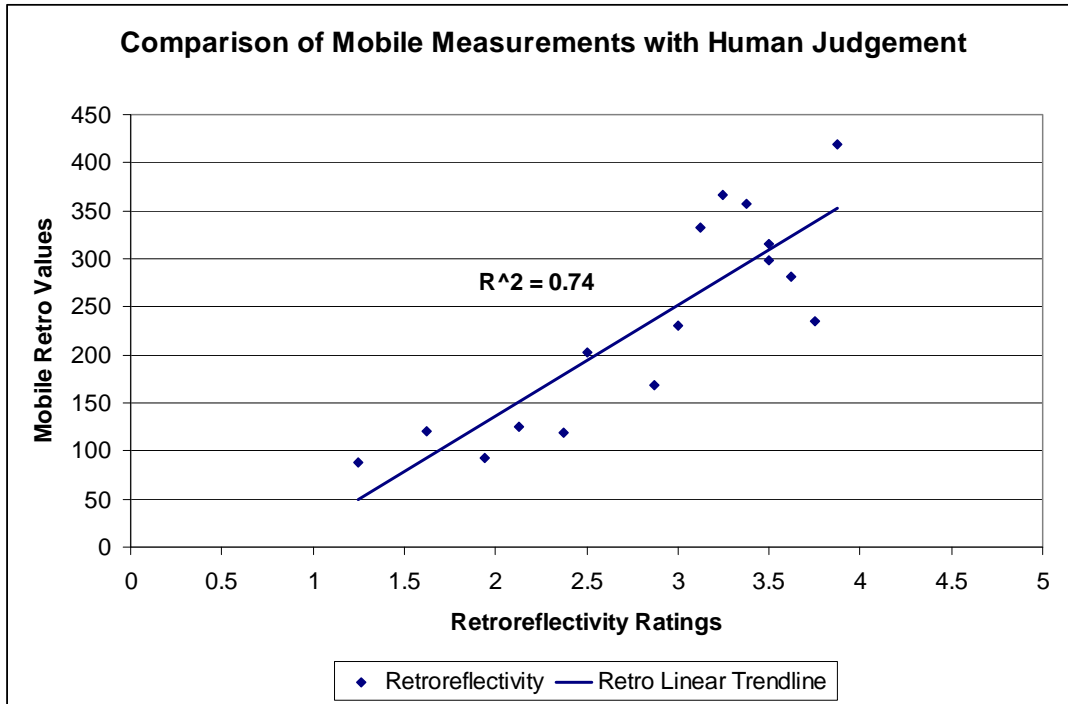

Figure 4. Correlation between Measured Retro Values and Subjective Retro-ratings.

In addition to the correlation analysis, researchers also looked for any trends in the retroreflectivity rating data. In this analysis, the researchers compared the average retroreflectivity rating trend with the actual measured retroreflectivity trend at each test segment. Figure 5 shows the trend analysis of the subjective retroreflectivity rating against measured retroreflectivity. The horizontal axis in Figure 5 shows the segment numbers arranged in ascending order of measured retroreflectivity values as obtained from a mobile unit (note that mobile values are factored by 100 to get to the same scale as ratings), and the vertical axis shows the average retroreflectivity ratings (average of individual ratings). The trend lines for measured values and retroreflectivity ratings are obtained by taking the moving average of consecutive readings.

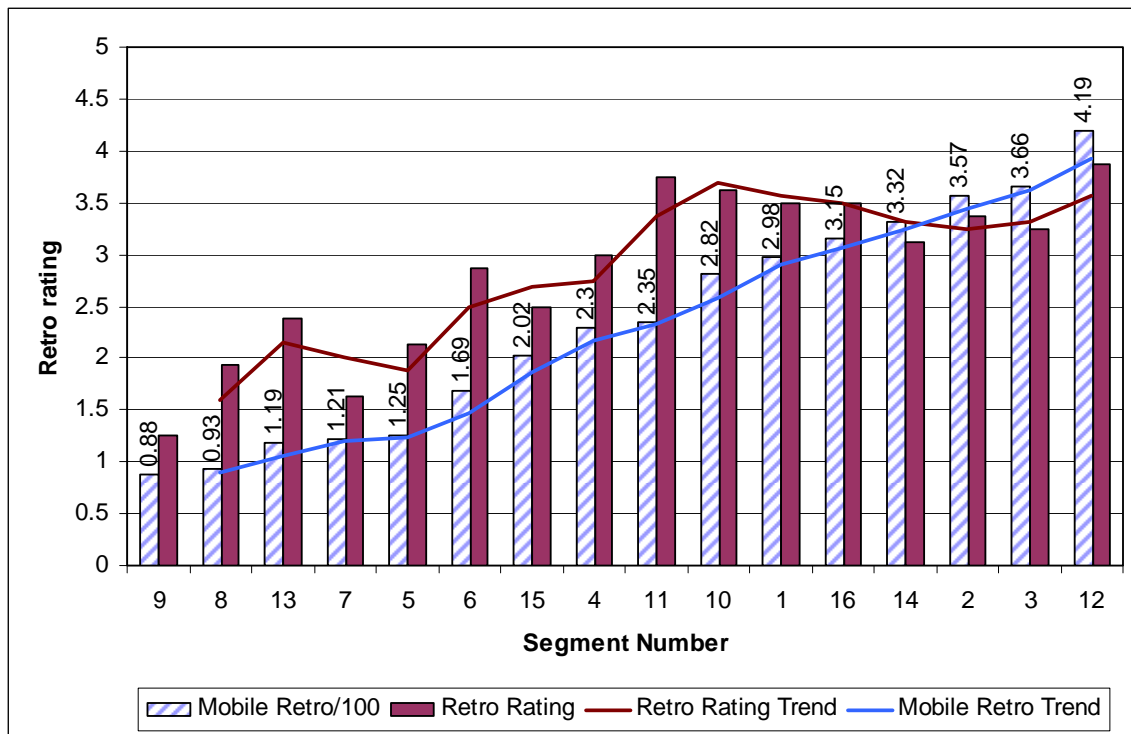

Figure 5. Retroreflectivity Rating Trend.

The trend analysis shows some trends in the ratings when compared to the retroreflectivity levels. For all retroreflectivity levels above 235 mcd/m²/lux, the rating is always between 3 and 4, whereas for retroreflectivity levels below 235 the ratings are always 3 or less. Also for retroreflectivity levels above 235 mcd/m²/lux, the rating is inconsistent in trend. Three of the four segments measuring less than 121 mcd/m²/lux received ratings of less than 2. There

were a few segments such as segment numbers 6, 11, and 13 where it seems like the difference between mobile retroreflectivity values and retroreflectivity rating values are higher than at other segments. The analysis (described in the next section) will explore any influence of marking and pavement type on the retroreflectivity rating.

4.1.3 Comparison of Retroreflectivity Ratings by Pavement and Marking Characteristics

Researchers were interested to determine if the pavement and marking characteristics had any influence in the subjective rating. Figure 6 shows a plot of retroreflectivity ratings for each test segment by pavement color, and Figure 7 shows the contrast rating for different combinations of pavement and marking color. The results indicate that dark pavements had a higher contrast rating than light pavements for markings with similar retroreflectivity levels. This typically resulted in retroreflectivity ratings that were higher for markings on dark colored pavements as compared to light colored pavements with similar retroreflectivity levels. This indicates that the contrast of the marking with the surrounding pavement can influence the subjective retroreflectivity rating of markings.

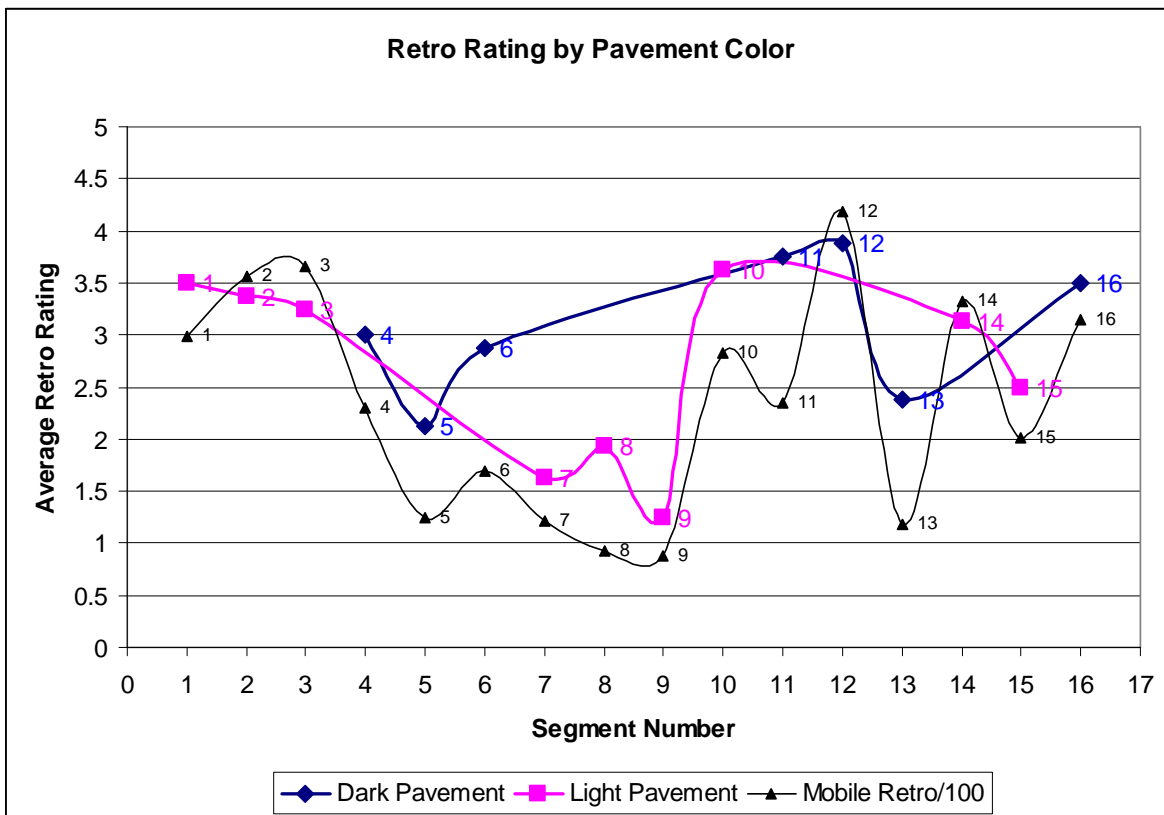

Figure 6. Retro Rating by Pavement Color.

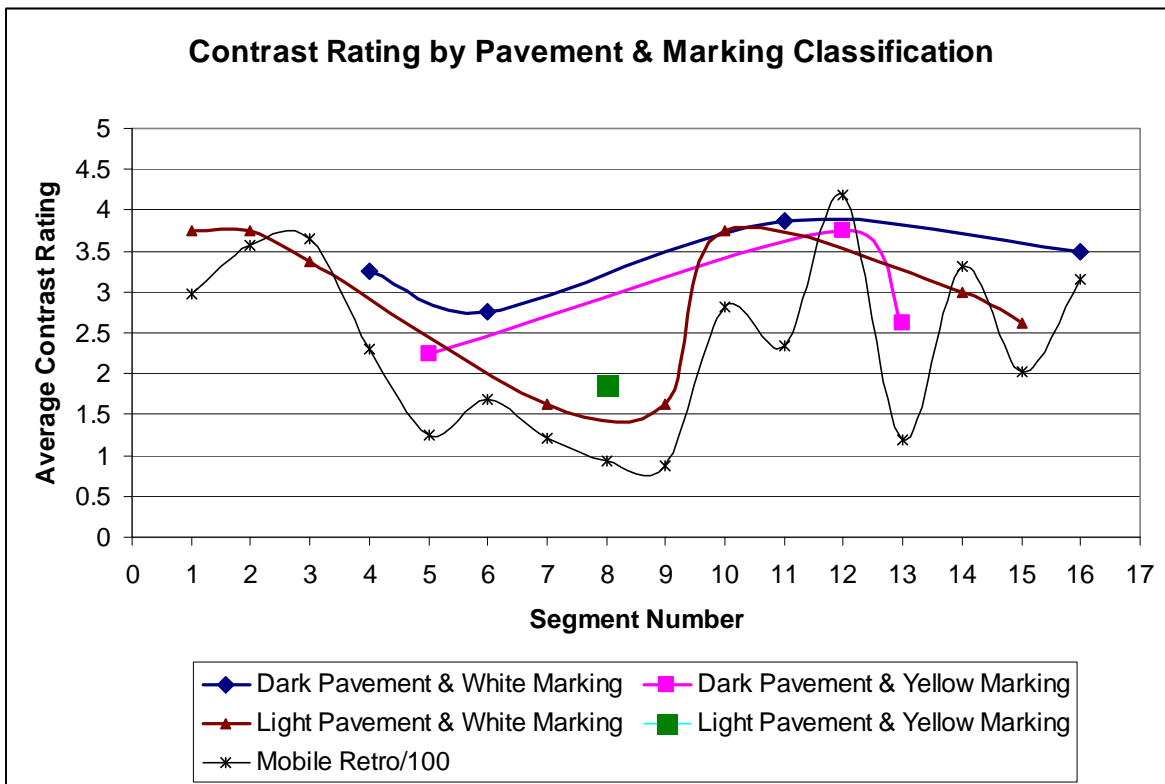

Figure 7. Contrast Rating by Pavement and Marking Color.

4.1.4 Individual Retro-Rating Analysis

Researchers analyzed the retro-ratings provided by each test participant individually. This analysis was done to find the difference:

- between individual ratings and the average retroreflectivity ratings, and
- between individual retroreflectivity ratings and mobile retroreflectivity values.

Table 13 shows the difference between individual ratings and average retroreflectivity ratings for all test segments. A negative value for the difference in ratings indicates that the subject underrated the marking retroreflectivity in comparison with the average rating for a given segment, while a positive value indicated that the subject over rated the marking retroreflectivity when compared to the average rating. The deviation for each participant was added up to compare the total deviation between all participants.

Table 13. Difference between Individual Ratings and Average Retroreflectivity Rating.

Segment #	Difference between Individual and Average Retroreflectivity Rating							
	Subject1 Delta	Subject2 Delta	Subject3 Delta	Subject4 Delta	Subject5 Delta	Subject6 Delta	Subject7 Delta	Subject8 Delta
1	-0.50	0.50	0.50	-0.50	0.50	0.50	-0.50	-0.50
2	-0.38	0.63	0.63	-1.38	0.63	0.63	-0.38	-0.38
3	-0.25	0.75	-0.25	0.75	-1.25	-0.25	0.75	-0.25
4	0.00	1.00	0.00	0.00	-1.00	0.00	1.00	-1.00
5	-0.13	-0.13	0.88	-0.13	-0.13	-0.13	-0.13	-0.13
6	0.13	0.13	0.13	0.13	-0.88	-0.88	1.13	0.13
7	0.38	0.38	-0.63	-0.63	-0.63	-0.63	2.38	-0.63
8	0.06	1.06	0.06	-0.94	0.06	1.06	-0.44	-0.94
9	0.75	0.75	-0.25	-0.25	-0.25	-0.25	-0.25	-0.25
10	-0.63	0.38	0.38	0.38	-0.63	-0.63	0.38	0.38
11	0.25	-0.75	1.25	-0.75	0.25	0.25	0.25	-0.75
12	-0.88	0.13	0.13	0.13	0.13	0.13	0.13	0.13
13	0.63	1.63	0.63	-1.38	0.63	-0.38	-0.38	-1.38
14	-0.13	-0.13	-1.13	0.88	0.88	0.88	-0.13	-1.13
15	0.50	0.50	0.50	0.50	-0.50	0.50	-0.50	-1.50
16	-0.50	-0.50	0.50	0.50	-0.50	0.50	0.50	-0.50
Absolute Total	6.06	9.31	7.81	9.19	8.81	7.56	9.19	9.94

Table 14 shows the difference between individual ratings and the measured retroreflectivity values for all test segments. A negative value for the difference in ratings indicates that the subject underrated the marking retroreflectivity in comparison with the measured mobile retroreflectivity value for a given segment, while a positive value indicated that the subject over rated the marking retroreflectivity when compared to the mobile retroreflectivity values. The absolute value of deviations from the mobile retroreflectivity values for each participant was added up.

Figures 8 and 9 show the comparison of individual ratings with average ratings and mobile retroreflectivity values for two of the test participants. The individual retroreflectivity rating graphs and the above two tables show that subjective ratings can significantly vary from individual to individual. The data also indicate that some evaluators were more consistent with the group and more consistent with the measured retroreflectivity than others. It is unknown if training the participants would improve the variation found in the subjective rating. Appendix C presents the rest of the individual rating graphs.

Table 14. Difference between Individual Ratings and Mobile Retroreflectivity Values.

Segment #	Difference between Individual Rating and Mobile Retroreflectivity/100							
	Subject1 Delta	Subject2 Delta	Subject3 Delta	Subject4 Delta	Subject5 Delta	Subject6 Delta	Subject7 Delta	Subject8 Delta
1	-0.57	0.43	0.43	-0.57	0.43	0.43	-0.57	-0.57
2	-0.57	0.43	0.43	-1.57	0.43	0.43	-0.57	-0.57
3	-0.66	0.34	-0.66	0.34	-1.66	-0.66	0.34	-0.66
4	0.70	1.70	0.70	0.70	-0.30	0.70	1.70	-0.30
5	0.75	0.75	1.75	0.75	0.75	0.75	0.75	0.75
6	1.31	1.31	1.31	1.31	0.31	0.31	2.31	1.31
7	0.79	0.79	-0.21	-0.21	-0.21	-0.21	2.79	-0.21
8	1.07	2.07	1.07	0.07	1.07	2.07	0.57	0.07
9	1.12	1.12	0.12	0.12	0.12	0.12	0.12	0.12
10	0.18	1.18	1.18	1.18	0.18	0.18	1.18	1.18
11	1.65	0.65	2.65	0.65	1.65	1.65	1.65	0.65
12	-1.19	-0.19	-0.19	-0.19	-0.19	-0.19	-0.19	-0.19
13	1.81	2.81	1.81	-0.19	1.81	0.81	0.81	-0.19
14	-1.30	-1.30	-2.30	-0.30	-0.30	-0.30	-1.30	-2.30
15	0.03	0.03	0.03	0.03	-0.97	0.03	-0.97	-1.97
16	-0.15	-0.15	0.85	0.85	-0.15	0.85	0.85	-0.15
Absolute Total	13.85	15.25	15.69	9.03	10.53	9.69	16.67	11.19

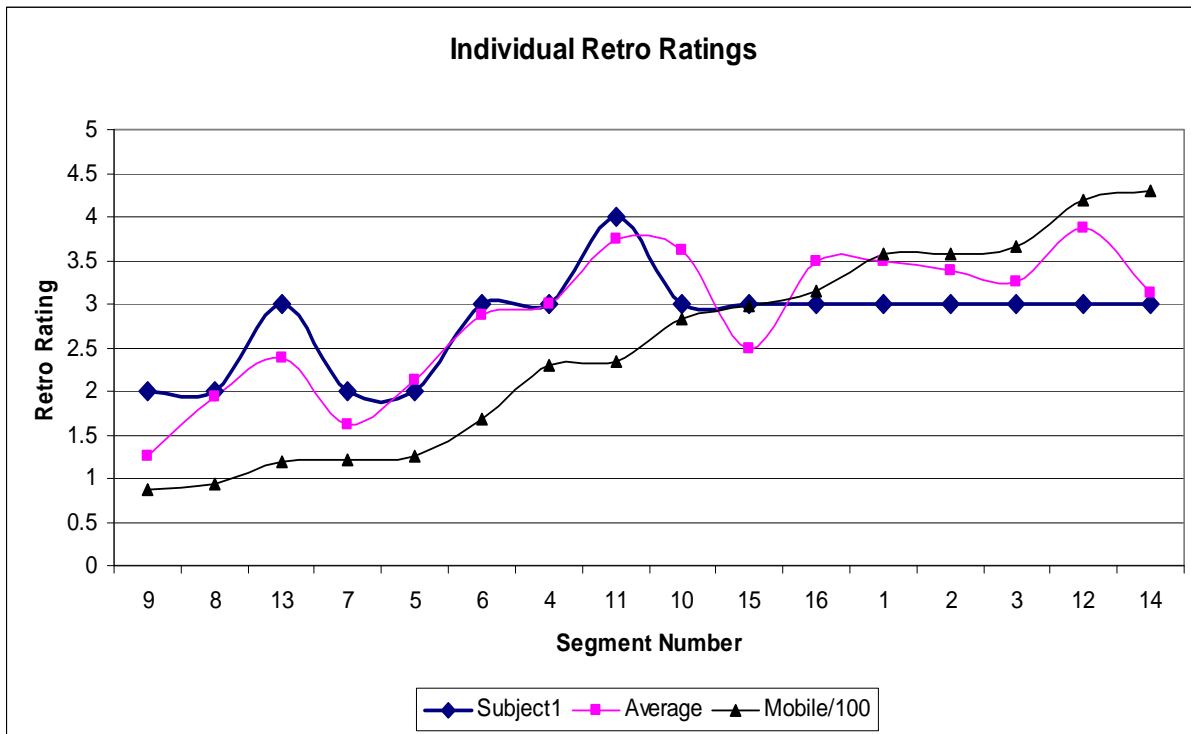

Figure 8. Individual Retro-ratings for Subject 1.

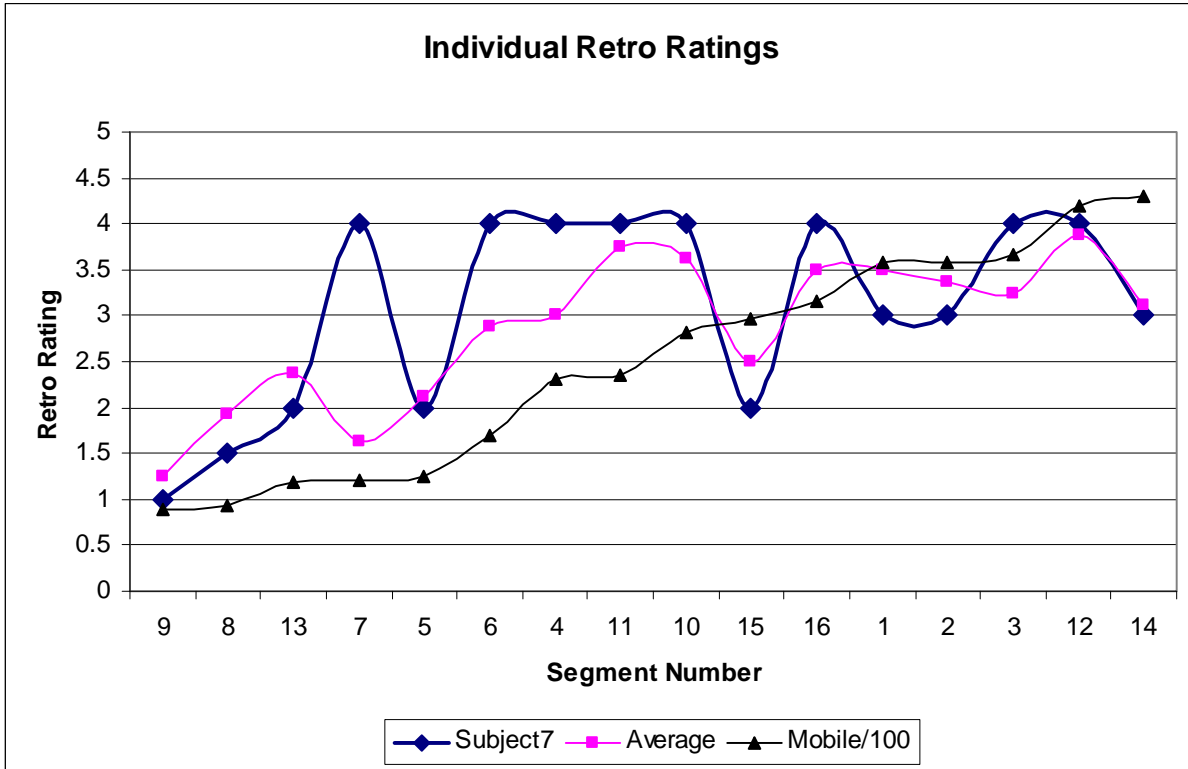

Figure 9. Individual Retro-ratings for Subject 7.

4.1.5 Comparison of Rating Factors Used for the Test

Although most of the results presented in this report are of retroreflectivity ratings, other factors such as color, contrast, and overall appearance were hypothesized to closely follow the trends shown by retroreflectivity ratings. Figure 10 shows average rating of different factors for each site. The ratings were found to be acceptably consistent between all factors.

Subjective rating can be biased by the individual evaluating the pavement markings. However if handheld or mobile retroreflectometers are not available for use, subjective rating could be used provided the evaluator is well trained or if multiple evaluators view each location and average ratings are reported.

Although this study provided some insights on subjective rating accuracy, a limited amount of data prohibited researchers from analyzing some trends that were expected to be observed. Also the participants in this study were not specifically trained to assess the retroreflectivity of pavement markings, but were familiar with retroreflectivity of pavement markings. The lack of training could have resulted in some inconsistent rating trends.

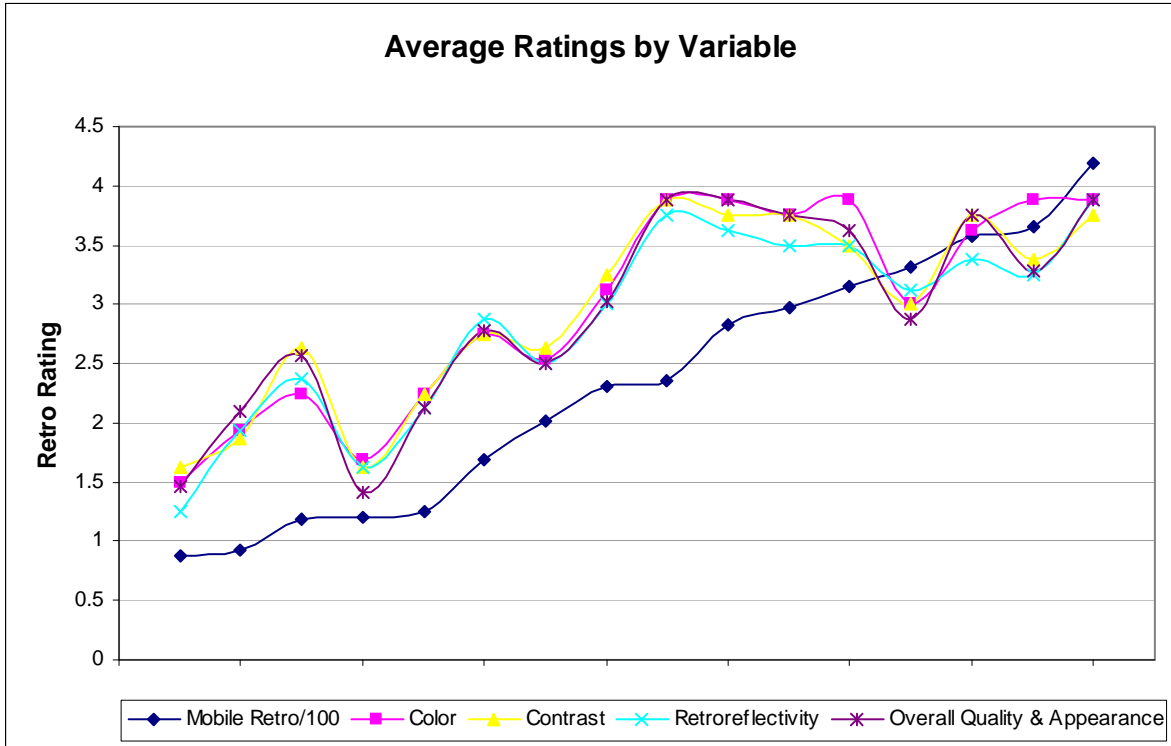

Figure 10. Average Rating of Different Factors Used in the Study.

4.2 SECOND NIGHT SUBJECTIVE RETROREFLECTIVITY TEST

The second subjective retroreflectivity assessment test intended to assess the rating ability of the participants and to see if minimal training improved the participant’s assessment abilities. This section provides details on the test procedure and the analyses that were carried out to identify trends and reliability of subjective evaluations.

4.2.1 Test Procedure

In this night test there were 11 participants of varied level of experience with respect to retroreflectivity assessment. All the participants in this study rode as passengers in a group of three or four participants in a TTI car and viewed a series of markings around the runways at the Texas A&M Riverside Campus. The study course had 12 different sections of test markings, each section being about 100 feet in length. The markings included yellow and white markings of varying retroreflectivity levels. The retroreflectivity of the test markings varied from 88 to 684 mcd/m²/lux. The participants were not informed of the retroreflectivity values until after the test was complete.

As the participants passed through the test markings along the route, the test vehicles stopped at two locations prior to the markings so that the markings could be viewed from a stationary location and at slow a speed when traveling between the locations. The test vehicle stopped at a distance of 210 feet and at 30-meters (98.4 feet). The 30-meter location was to represent a similar geometry to that at which the pavement marking retroreflectivity is measured. The 210-foot location was the distance at which a driver would have a 2.2 second preview time of the marking when traveling at 65mph. The participants were asked to rate the markings that they see on a scale of 1 to 5, with 1 implying immediate replacement required and 5 implying like new. Participants were also asked to estimate the retroreflectivity levels of the markings. Once a group of participants had finished assessing all the test markings, they were taken to a different location for a brief training session on pavement marking retroreflectivity levels.

The training area consisted of a two sets of markings. The first set had eight yellow lines of varying retroreflectivity levels and the second set had eight white lines of varying retroreflectivity levels. A car with a group of participants was parked in line with the markings at a distance of 30-meters from the markings. Initially the participants were asked to rank order the markings in order of highest to lowest retroreflectivity. Later the participants were handed a sheet with the actual measured retroreflectivity values of the training sets and were asked to get familiar with the test set and their corresponding retroreflectivity values. After completing the training, participants were again driven along the test course to re-assess the 12 test markings, which they had earlier rated.

4.2.2 Individual Retroreflectivity Assessment: Before-After Analysis

Retroreflectivity assessment of the test markings for each individual before training and after training was compared. [Figures 11](#) and [12](#) show typical retroreflectivity estimate results of an experienced assessor and an inexperienced assessor respectively. In [Figures 11](#) and [12](#), the black line indicates the actual measured retroreflectivity, the blue line indicated the assessed subjective retroreflectivity before the training, and the pink line indicated the assessed subjective retroreflectivity after the training. Individual retroreflectivity assessment data showed a lot of inconsistency in terms of if training helped test participants to assess the markings better. Some individuals did better overall after training, some got worse, and others had no change overall. However a majority of the participants did get closer to the actual retroreflectivity after training

in the case of the test marking which had the highest retroreflectivity (684 mcd/m²/lux). Individual retroreflectivity assessment of other participants is provided in [Appendix D](#) of this report. The estimated pavement marking retroreflectivity levels and the rating of the markings followed a similar trend.

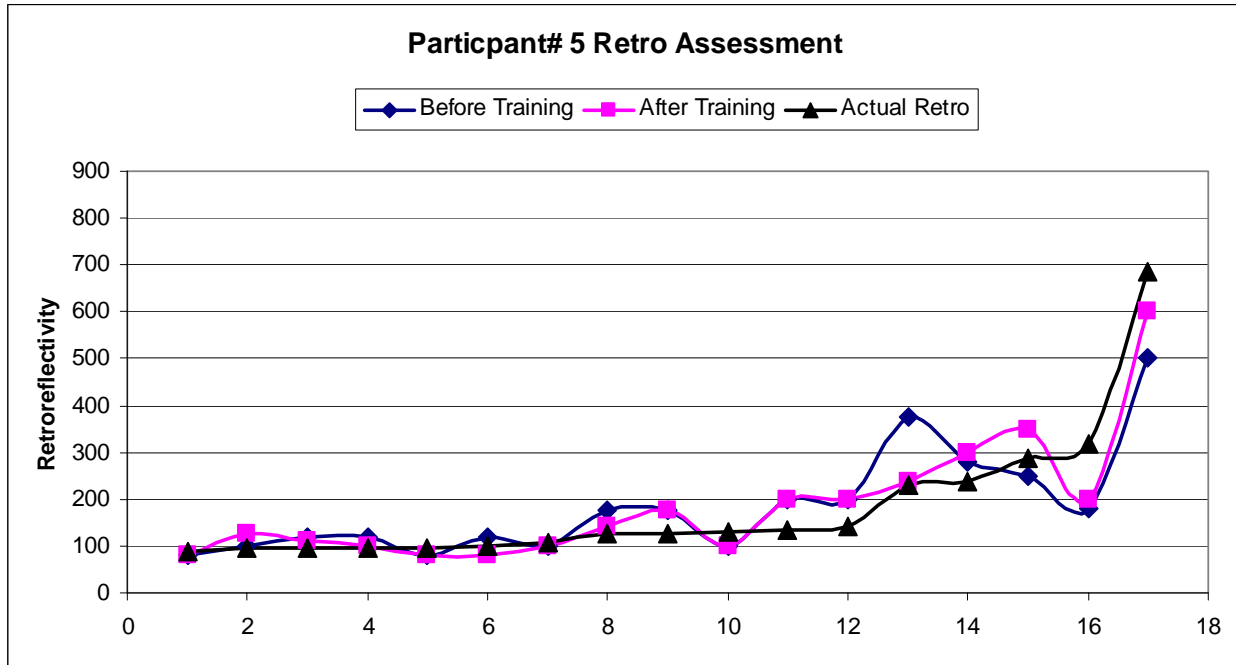

Figure 11. Retroreflectivity Assessment Graph for Participant #5.

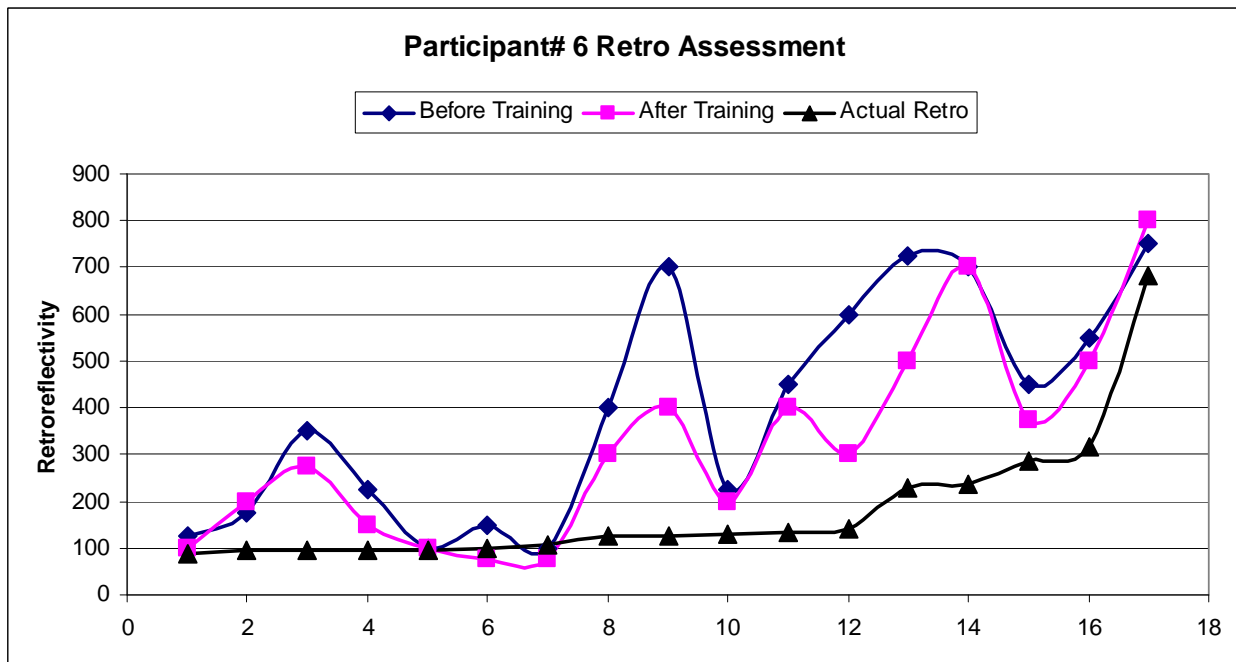

Figure 12. Retroreflectivity Assessment Graph for Participant #6.

4.2.3 Before-After Analysis of Average Subjective Retroreflectivity

A before-after comparison was also conducted on the average retroreflectivity assessment. [Table 15](#) shows the percentage difference from the actual retroreflectivity for before training and after training assessment period. [Tables 16](#) and [17](#) show similar statistics with participants segregated as experienced and inexperienced, respectively. Participants who had previous experience dealing with pavement marking retroreflectivity were classified as experience and others as inexperienced. Comparison of standard deviations before and after training did not show improvement as a result of training at many test sections for the experienced participants, on the other hand the training seemed to positively affect the inexperienced participants by lowering the standard deviation between their estimates. Also, the comparison of average subjective retroreflectivity with the actual retroreflectivity did not show any consistent improvement after training.

4.2.4 Subjective Retroreflectivity Assessment Trend by Pavement Marking Color

In this analysis a trend chart was developed depicting the actual retroreflectivity trend and subjective retroreflectivity trends before and after training. These trend charts were developed separately for yellow markings and white markings as shown in [Figures 13](#) and [14](#).

For yellow markings, the subjective retroreflectivity trend was consistently higher than the actual retroreflectivity. Comparing the subjective retroreflectivity trend before and after training, it can be seen that the after training trend closely follows the before training trend at least for sections less than $150 \text{ mcd/m}^2/\text{lux}$. The difference being that the retroreflectivity was assessed much higher after training than before training. This indicates that the minimal training provided did not influence the relative assessment capabilities of the participants.

In the case of white markings, subjective retroreflectivity assessment before training showed to underestimate marking with retroreflectivity less than $120 \text{ mcd/m}^2/\text{lux}$ and greater than $250 \text{ mcd/m}^2/\text{lux}$, and anything between 120 to $250 \text{ mcd/m}^2/\text{lux}$ was overestimated. With white markings too, the training provided did not influence the relative assessment of retroreflectivity and only resulted in participants assessing the markings at a higher retroreflectivity value than they had assessed before training.

Table 15. Before-After Retroreflectivity Assessment Statistics for All Participants.

Section#	Marking Type	Actual Retro	Average Retro		Std Deviation for Subj Retro		Difference in Retro		% Difference	
			Before training	After Training	Before training	After Training	Before - Actual	After - Actual	Before - Actual	After - Actual
9	Yellow	88	63	84	13.964	53.549	-25	-4	-28%	-5%
6	White	94	96	125	19.812	39.528	2	31	2%	33%
4	Double Yellow	95	91	107	23.921	57.488	-4	12	-4%	13%
7	Yellow	95	116	135	20.736	48.734	21	40	22%	42%
5	White	96	63	79	13.964	24.597	-33	-17	-34%	-18%
12	Yellow	98	87	109	36.332	73.689	-11	11	-11%	11%
9	White	108	76	97	25.100	60.581	-32	-11	-30%	-10%
3	Yellow	125	130	152	32.596	84.380	5	27	4%	22%
1	Yellow	127	139	199	34.169	96.203	12	72	9%	57%
7	White	131	128	145	43.818	77.862	-3	14	-2%	11%
11	White	133	200	242	61.237	65.727	67	109	50%	82%
1	White	141	159	230	30.083	105.178	18	89	13%	63%
10	Double Yellow	230	301	291	111.379	90.545	71	61	31%	26%
2	White	238	256	322	62.690	167.093	18	84	8%	35%
12	White	286	245	345	57.009	141.863	-41	59	-14%	21%
5	Yellow	317	235	336	116.512	138.672	-82	19	-26%	6%
8	White	684	421	630	117.068	148.324	-263	-54	-38%	-8%

Table 16. Before-After Retroreflectivity Assessment Statistics for Experienced Participants.

Section#	Marking Type	Actual Retro	Average Retro		Std Deviation for Subj Retro		Difference in Retro		% Difference	
			Before training	After Training	Before training	After Training	Before - Actual	After - Actual	Before - Actual	After - Actual
9	Yellow	88	65	96	23.238	40.855	-23	8	-26%	9%
6	White	94	106	140	29.588	42.863	12	46	13%	49%
4	Double Yellow	95	117	141	85.971	72.670	22	46	23%	48%
7	Yellow	95	118	145	50.610	41.653	23	50	24%	53%
5	White	96	82	110	33.043	56.190	-14	14	-14%	15%
12	Yellow	98	100	116	48.911	60.004	2	18	2%	19%
9	White	108	72	101	21.373	47.160	-36	-7	-33%	-7%
3	Yellow	125	145	188	91.104	74.809	20	63	16%	51%
1	Yellow	127	181	225	176.434	96.203	54	98	42%	77%
7	White	131	128	164	47.868	67.373	-3	33	-2%	25%
11	White	133	225	298	95.743	102.085	92	165	69%	124%
1	White	141	184	222	143.946	91.986	43	81	30%	57%
10	Double Yellow	230	324	374	157.518	140.692	94	144	41%	63%
2	White	238	254	353	162.831	171.877	16	115	7%	48%
12	White	286	242	328	94.508	126.617	-44	42	-15%	15%
5	Yellow	317	265	373	130.316	112.966	-52	56	-16%	18%
8	White	684	404	641	150.811	149.697	-280	-43	-41%	-6%

Table 17. Before-After Retroreflectivity Assessment Statistics for Inexperienced Participants.

Section#	Marking Type	Actual Retro	Average Retro		Std Deviation for Subj Retro		Difference in Retro		% Difference	
			Before training	After Training	Before training	After Training	Before - Actual	After - Actual	Before - Actual	After - Actual
9	Yellow	88	67	106	30.277	28.003	-21	18	-24%	20%
6	White	94	115	153	35.214	44.572	21	59	22%	63%
4	Double Yellow	95	139	169	114.198	74.056	44	74	46%	78%
7	Yellow	95	120	153	69.065	37.238	25	58	26%	61%
5	White	96	98	137	36.697	63.377	2	41	2%	42%
12	Yellow	98	110	123	58.652	52.512	12	25	12%	25%
9	White	108	69	104	19.600	38.525	-39	-4	-36%	-4%
3	Yellow	125	158	218	123.845	55.648	33	93	26%	75%
1	Yellow	127	216	247	241.048	99.331	89	120	70%	94%
7	White	131	128	180	55.197	59.666	-3	49	-2%	37%
11	White	133	250	345	123.744	107.703	117	212	88%	159%
1	White	141	204	215	199.008	89.163	63	74	45%	52%
10	Double Yellow	230	344	443	196.490	142.586	114	213	50%	93%
2	White	238	253	378	223.333	187.127	15	140	6%	59%
12	White	286	240	313	123.491	124.164	-46	27	-16%	10%
5	Yellow	317	291	404	146.302	87.202	-26	87	-8%	27%
8	White	684	390	650	184.391	164.317	-294	-34	-43%	-5%

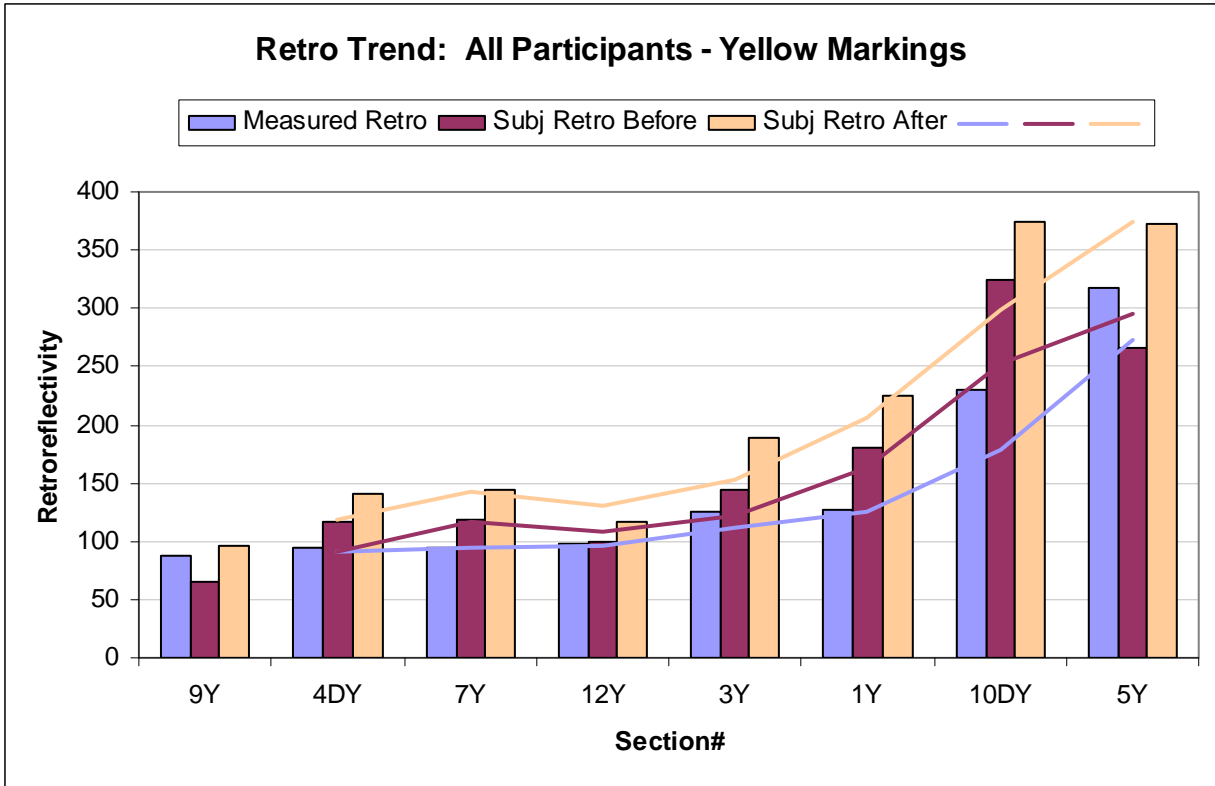

Figure 13. Retroreflectivity Assessment Trend for Yellow Markings.

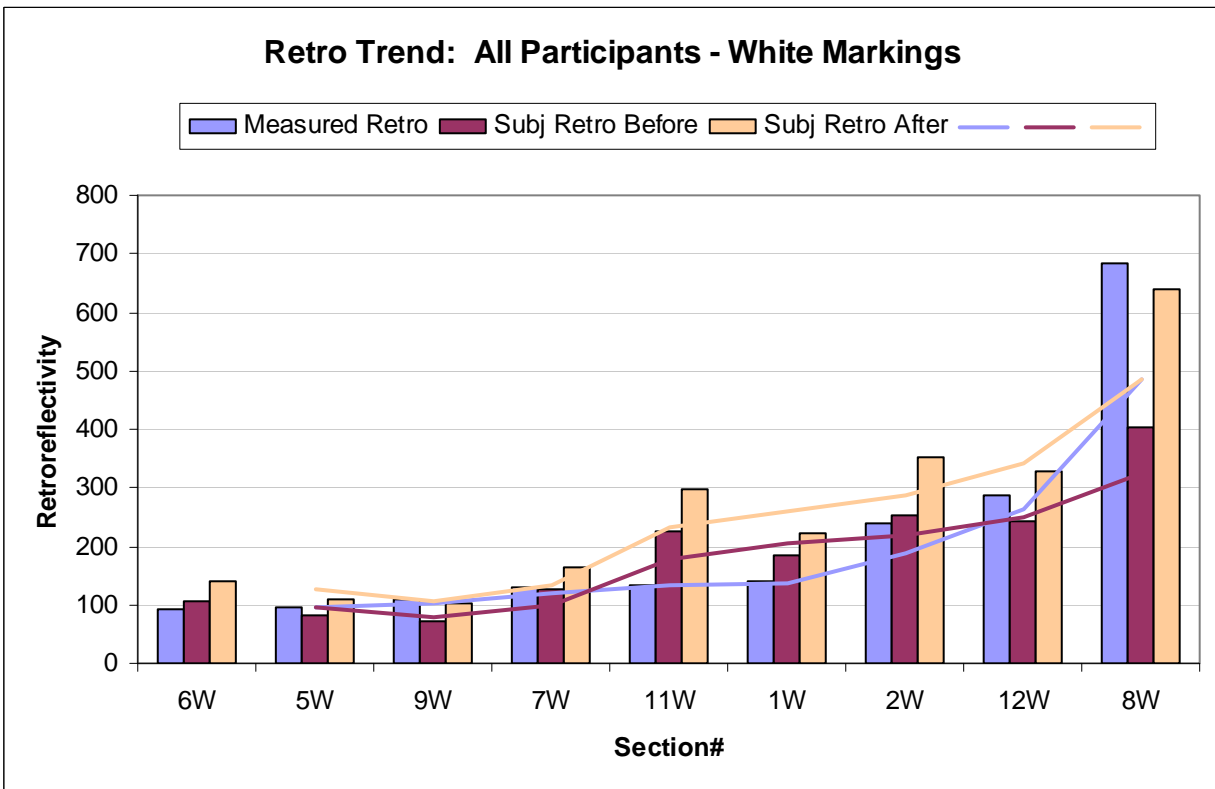

Figure 14. Retroreflectivity Assessment Trend for White Markings.

4.2.5 Discussion

Data analyzed from the second night retroreflectivity test indicate that minimal training provided to the participants did not seem to improve the participants' evaluation of pavement marking retroreflectivity. On contrary to what was expected, the participants actually overestimated the retroreflectivity values of the test sections by a larger amount after the training. Some of the possible reasons for such unexpected results could be due to:

- inadequate training (not enough time and too many training lines),
- training cautioned the participants rather than educating them, and
- training and actual assessment not done under same environment.

The rank order of the training markings provided consistent and accurate results from all participants. This indicates that when markings of varying retroreflectivity levels are placed side by side that subjects can accurately rank order them from best to worst. In evaluation of the other test markings and evaluating markings on actual roads, there is only a single marking of a given color so comparisons cannot be made. The lack of other markings and standards to indicate what a good marking should look like can lead to inconsistent results.

As such from this test no conclusion can be drawn on the impact of the training on accuracy of subjective evaluations. Subjective rating can be biased by the individual evaluating the pavement markings. However if handheld or mobile retroreflectometers are not available for use, subjective rating could be used provided the evaluator is well trained or if multiple evaluators view each location and average ratings are reported.

4.3 COMPARISON OF HANDHELD AND MOBILE RETROREFLECTOMETER READINGS

Utilizing information learned from the mobile retroreflectometer testing (Report [Section 5](#)), the researchers conducted a comparison of mobile retroreflectivity data collection to handheld retroreflectivity data collection. The pavement marking retroreflectivity data collection was conducted on 14 different sections of road. The length of each road section varied between 0.05 and 0.48 miles long. The average section length was 0.31 miles. These sections represented the typical road surface types in Texas (i.e., asphalt, Portland cement concrete, and seal coat) and the typical range of pavement marking retroreflectivities. The road sections used for the mobile

versus handheld retroreflectivity comparison are the same sections used for the first night study described in Report [Section 4.1](#).

The researchers collected all mobile and handheld retroreflectivity data on the same day so that environmental factors and traffic conditions would not be a factor. The researchers collected the mobile retroreflectivity data at the posted speed (30-70 mph) along the entire length of the test sections. The researchers calibrated the mobile retroreflectometer once for each color prior to going out and collecting data at all the sites of that color. The researchers conducted handheld data collection along the second half of each section, except for the shorter sections where it was conducted along the whole length. The researchers collected a minimum of 16 handheld measurements for each section. The researchers compared the data from the handheld readings to the mobile readings along the same part of each section, i.e., if the whole section was measured with a handheld retroreflectometer the mobile value for the whole section was used, or if handheld data were only collected on the second half of a section then only the second half of the mobile values were used.

[Figure 15](#) displays the average retroreflectivity values from the mobile and handheld data collection. Two linear regression lines are also on the figure indicating two best fit scenarios. If the two devices matched each other perfectly a linear regression would have a slope of one, a y-intercept of zero, and R^2 value of one. The dashed line represents a best fit linear regression that has the highest coefficient of determination. The 0.9794 R^2 value indicates a very high correlation between the two values, meaning that the two values follow a similar trend. The slope of 0.9355 and the y-intercept of 14.081 indicate that there is a slight bias between the two devices. Even with this bias the percent difference is less than 4 percent for value ranging from 135 to 550. The solid line represents a best fit linear regression that has the y-intercept set at zero. The 0.9766 R^2 value though slightly lower than the best fit regression line still indicates a very high correlation between the two values. The slope of 0.9799 indicates that the two devices are very similar in their results. Since the y-intercept was forced through the zero point, the percent difference anywhere on the line is constant at about 2 percent.

The results from this evaluation indicate a very strong correlation between the handheld and mobile measurements. Not only is the correlation strong, but the magnitude of the values are also very close as indicated by the less than 4 percent difference. With proper equipment setup,

calibration, and testing procedures, accurate mobile retroreflectivity data can be collected across a variety of retroreflectivity and road surface types.

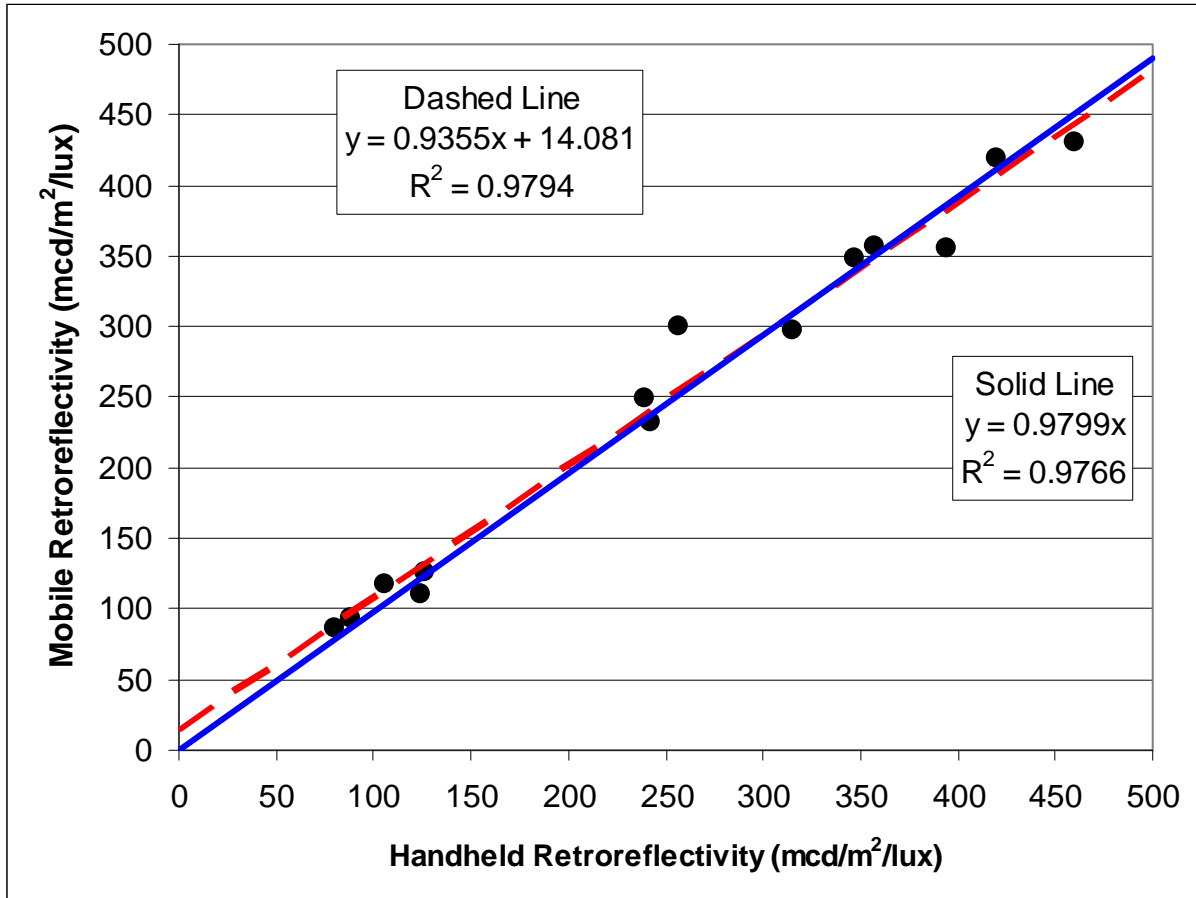

Figure 15. Comparison of Mobile and Handheld Retroreflectivity Measurements from Night Study 1.

CHAPTER 5. MOBILE MEASUREMENTS AND BEST PRACTICES

The future of mobile retroreflectivity data collection will rely on the ability of the users to collect accurate and reliable data. The ability of TxDOT to plan and monitor mobile retroreflectivity data collection will impact the results and the ability of the data to meet TxDOT's needs. An understanding of the mobile retroreflectivity equipment, data collection process, and resulting data are imperative for both planning and monitoring data collection to ensure that the appropriate measures are taken to provide the best data possible. This chapter will evaluate the impact that several variables have on mobile retroreflectivity data collection and will also recommend the best methods to limit the impact of the influencing variables. This chapter will also evaluate different sampling methods for collection of retroreflectivity data.

5.0 SENSITIVITY ANALYSIS OF MAJOR VARIABLES

The objective of this section is to evaluate the ability of the Laserlux mobile retroreflectometer to accurately measure the retroreflectivity of pavement markings by conducting a series of tests evaluating several variables that may affect the accuracy of the data collected by the retroreflectometer. The literature review and experiences using the mobile retroreflectometer provided the researchers with numerous variables to evaluate. The magnitude of the impact of the variables can be found through testing, so isolation of the variables as best as possible is critical to determine the true impact. The initial data collection towards this effort was conducted in a controlled environment to isolate the variables that impact the quality and accuracy of the data collection process. Measurements were taken while only varying a single variable and holding the other variables as constant as possible. Variables that cannot be isolated were evaluated in a manner that limits the impact of the other variables.

Quantification and verification of the effects of these factors are necessary for two reasons. The first is to develop best practices for calibration and operation of mobile retroreflectometers. The second is to scientifically arrive at correction factors that can be applied to the measurements when any deviation from the standard calibration is noticed while measuring retroreflectivity with mobile retroreflectometers. Measurements made on pavement markings are inherently variable due to variability along the pavement marking. Small movements of a retroreflectometer along a marking will yield differing retroreflectivity results. The researchers attempted to measure the marking in similar locations and to select markings

that had a small variation along their length to minimize the natural marking variability as much as possible.

5.0.1 Static Testing

Static testing of the mobile retroreflector was carried out inside a large garage to reduce any effects of changing sunlight conditions and to minimize temperature changes due to the sun. This environment provided the best setup for minimizing variables other than those being evaluated. The mobile retroreflector was mounted to the vehicle as it would normally be for data collection. All data were collected without anyone inside the vehicle so that the platform would not move at all during the data collection. Pavement marking panels measuring 4 ft in length were used as the test markings.

5.0.1.1 Measurement Geometry

The researchers conducted testing of improperly setting up the retroreflector to the 30-meter geometry to evaluate two different variables. The first variable the researchers tested was the effect of not properly setting the height on the retroreflector when setting up. The second variable the researchers evaluated was the effect of varying the measurement distance from the mobile retroreflector.

To test the effect of not properly setting the height, the researchers set up the mobile retroreflector in the standard position and then made minor adjustment to test varying conditions. The conditions that were tested as follows: correct setup, 0.25 inches high, 0.5 inches high, 0.25 inches low, 0.5 inches low, front 0.25 inches low, front 0.25 inches high, back 0.25 inches low, and back 0.25 inches high. After setting up the retroreflector to the given condition, the laser was positioned on the test panel at the 10-meter mark by using the computer controlled adjustable tilt motor. The retroreflectivity of the panel at the geometry being evaluated was then measured. [Table 18](#) shows the results of the testing.

Comparing the eight setups to the standard setup with the correct geometry yielded some significant results. In several cases the difference was found to be statistically significant at a 0.05 level of confidence. Though there were significant differences, the magnitude of the differences ranged from 0 to 6.2 percent. These differences are not really practical though since measuring the marking in a slightly different position could account for the change. The

differences were not always consistent (note the differences measuring at the correct geometry), which also indicates that the measurement location on the stripe may have changed slightly between each of the different setups.

Table 18. Height Setup Testing.

Setup Conditions	Retroreflectivity
correct geometry	497
0.25 inch high front and back	525
0.5 inch high front and back	528
0.25 inch low front and back	510
0.5 inch low front and back	499
correct geometry	520
Front .25 low, back correct	525
Front .25 high, back correct	504
Front correct, back .25 low	520
Front correct, back .25 high	515

To test the effect of measurement distance, the researchers set up the mobile retroreflectometer in the standard position and then made adjustments to the distance at which the retroreflectometer was measuring the marking. The marking was measured at 7.5, 8, 9, 10 (standard distance), 11, 12, and 13 meters. At each measurement distance, the pavement marking sample was moved, and the laser was repositioned at the center of the marking.

Figure 16 displays the results of the measurement distance testing. There is a consistent relationship between measurement distance and retroreflectivity level, which is that as measurement distance increases retroreflectivity decreases. This effect shows a significant difference between measurement distances.

The researchers believe that the internal user adjustable tilt motor that positions the laser is able to compensate for the small differences in the setup geometry that were tested. When the geometry was changed either up or down, the laser was then adjusted in the opposite direction to keep the reading at the 10-meter mark. The results of this testing did not result in practical differences when considering the inherent variability of the marking. In contrast, when measuring the marking at the incorrect distance, significant differences were found. This means that when setting up the retroreflectometer it is imperative to setup on a level area and to ensure that the laser is positioned on the marking at exactly 10 meters.

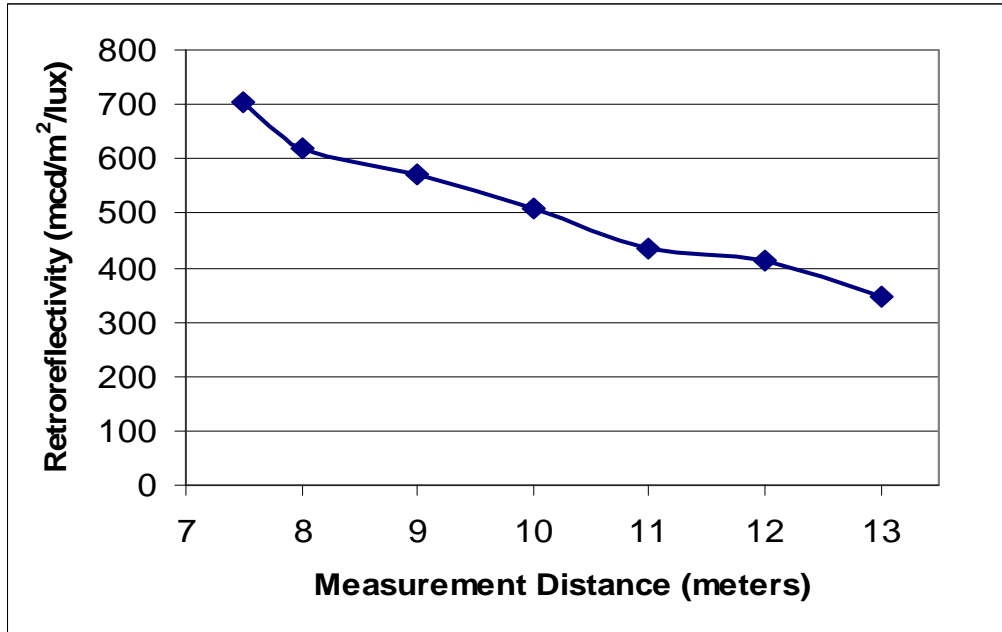

Figure 16. Measurement Distance Testing.

5.0.1.2 Temperature

The researchers conducted an evaluation of the impact of internal retroreflectometer temperature. The retroreflectometer itself will heat up if the laser is continuously on, but the impact of the sun and external temperature are the major sources of internal heating. Since the retroreflectometer is attached to the outside of the vehicle, on sunny days the exterior of the retroreflectometer box will heat up causing the internal components to heat up as well. The effect of this internal heating is a major cause of concern in Texas where large temperature differences and a hot summer sun can cause large internal temperature changes.

The researchers conducted this study in two steps. The first step was to determine the impact of the temperature change on the retroreflectometer. The second was to use the temperature compensation algorithm that is built into the retroreflectometer software and the results of our temperature testing to try and compensate for the temperature effect.

The first step was carried out in multiple phases to see how consistent the effects of temperature change were. [Figure 17](#) displays the results of the temperature testing. Initially the retroreflectometer was set up at the correct geometry in the garage location to reduce the effects of other variables. The retroreflectometer exterior was then heated with a kerosene space heater so that the internal temperature would increase. Tests 1 and 2 were both conducted in this

manner. Tests 6 and 5 were the cooling of the retroreflectometer back to the ambient room temperature after heating the unit from Tests 1 and 2. For Tests 3 and 4 conducted outside during the hottest part of the day, the sun heated the retroreflectometer while it collected data.

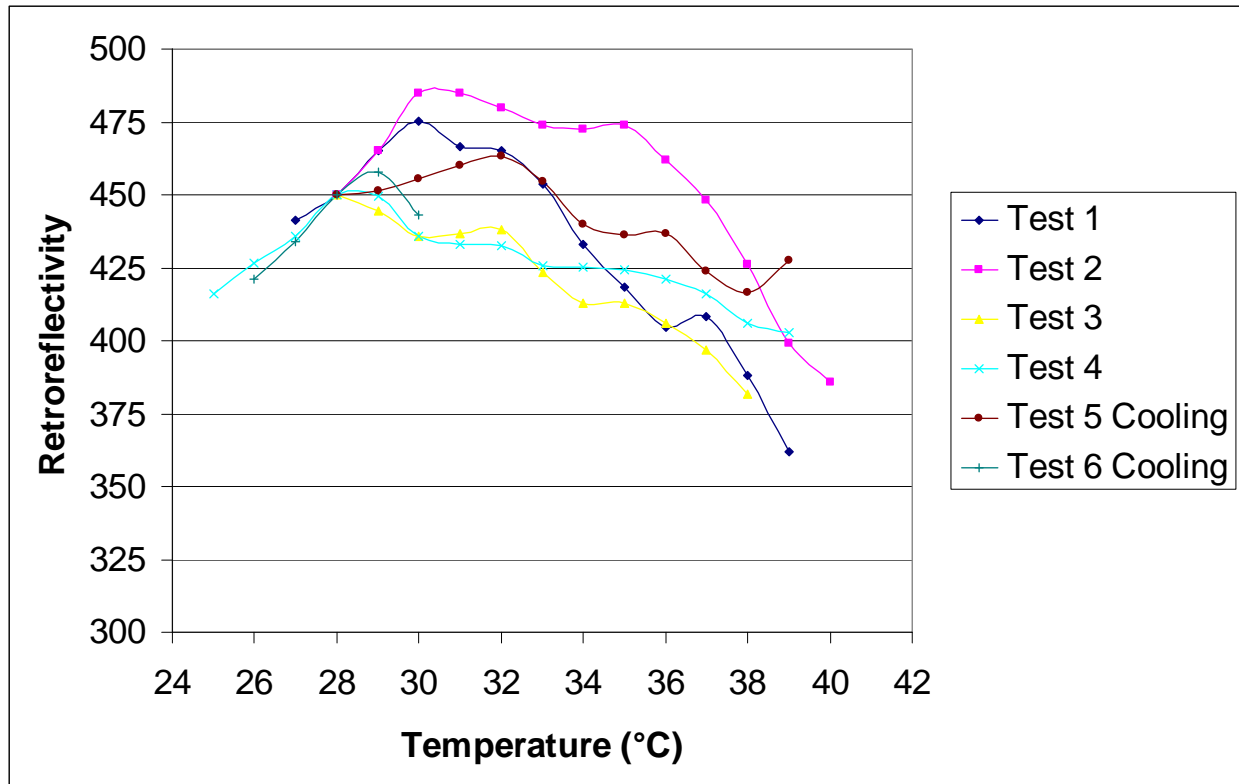

Figure 17. Temperature Characterization Testing.

The results from the characterizing of the retroreflectometer were averaged to determine the difference as the temperature changes. The red line in [Figure 18](#) displays this average. These differences were input into the temperature compensation algorithm that is in the software for the retroreflectometer. The compensation requires the input of temperature differences at 5 degree intervals, where all temperatures are in degrees Celsius. The temperature range in the compensation is between 5°C and 50°C. The data from the characterization allowed for accurate inputs of correction values between 25°C and 40°C. The values outside of our testing were extrapolated based on an assumption that the data would follow a similar pattern. The researchers then tested the temperature sensitivity of the retroreflectometer with the temperature compensation turned on. The retroreflectometer was placed outside and allowed to heat by the sun. The results of the data collected with the compensation can be seen in

Figure 18. The red line represents the average retroreflectivity values across the temperatures tested without the compensation. The blue line represents the data with the compensation on. The purple line represents the data from one of the individual trials without the compensation when the retroreflectometer was heated outside. The retroreflectivity level of the marking measured was $450 \text{ mcd/m}^2/\text{lux}$. Figure 18 clearly indicates that the compensation greatly improved the ability of the mobile retroreflectometer to accurately measure the pavement marking as the temperature increased.

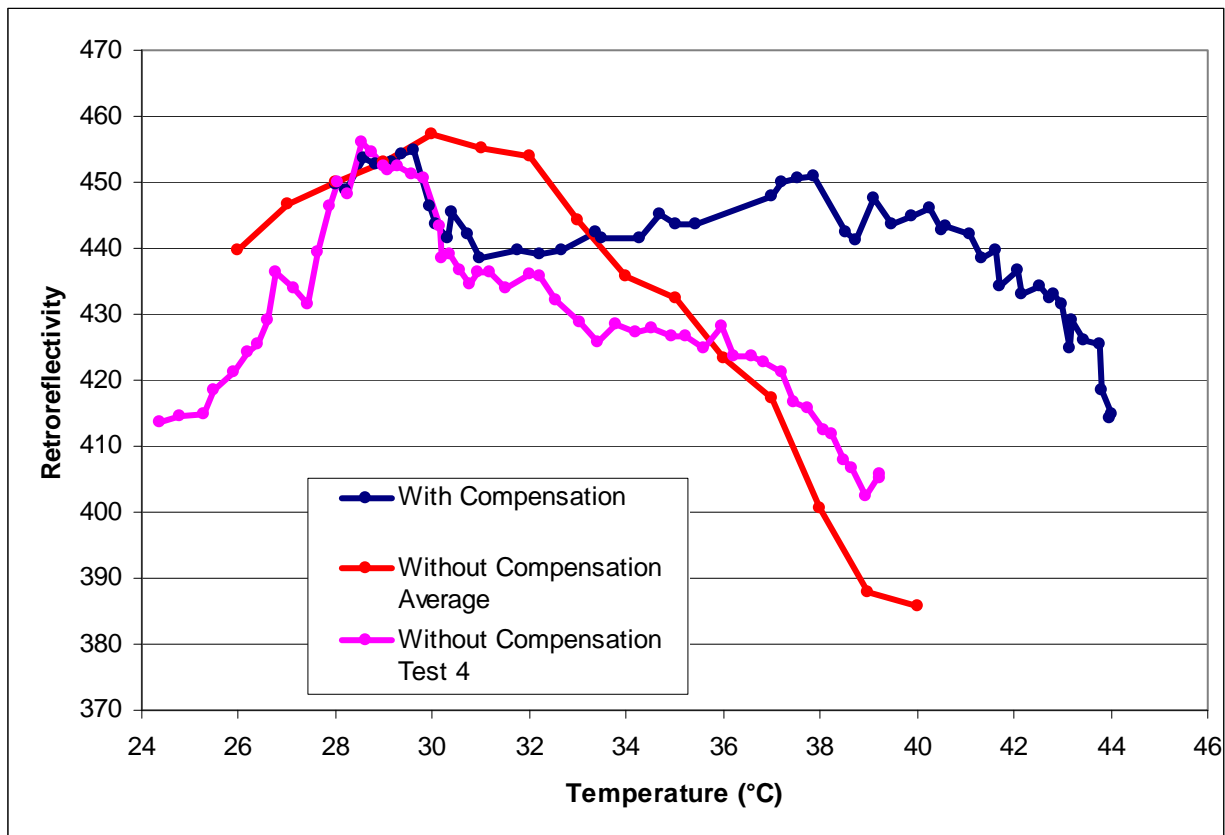

Figure 18. Temperature Compensation Testing.

Over the temperature range tested without compensation, the temperature lowered the average retroreflectivity by over 14 percent. With the compensation over the range that had accurate compensation values, the maximum difference was less than 3 percent. For the temperature values outside of those during the temperature characterization without the compensation, the results of the compensation were not as good. The difference at the maximum temperature tested was 8 percent with the compensation on. The researchers feel that

modifications to the compensation values that were outside of those originally tested will be able to correct for this difference if tested again.

The researchers found that the temperature compensation that is built into the software is able to greatly reduce the effect of temperature change on the accuracy of the retroreflectivity data. A large range of temperatures needs to be tested to ensure that the compensation values input are correct. Also, an external thermoelectric cooler with a thermostat control that is built onto the retroreflectometer is a viable means to control the temperature of the retroreflectometer and thus account for changing temperatures.

5.0.1.3 Linearity

The researchers conducted linearity testing of the mobile retroreflectometer to evaluate the effect of calibrating on a marking of a certain value and then measuring markings of differing values. The researchers tested three different scenarios in which the mobile retroreflectometer was calibrated at a low (145 mcd/m²/lux), medium (346 mcd/m²/lux), and high (761 mcd/m²/lux) retroreflectivity level. The mobile retroreflectometer was calibrated on a panel that was measured with the handheld retroreflectometer at the previously listed values. After each calibration of the retroreflectometer, eight pavement markings of varying retroreflectivity levels were measured. The retroreflectivity output from the mobile retroreflectometer was compared to the value measured with a handheld retroreflectometer. [Figure 19](#) displays the results of the testing.

Examining the data indicates that there is an effect from calibrating on a marking that has a different retroreflectivity level than the markings that are being measured. The data from the high retroreflectivity markings were skewing the regression lines and were not included, only the markings with more typical retroreflectivity levels were included. [Figure 18](#) displays that the correlation between the handheld measurements of the panels and the mobile measurements was very good in all three conditions. The slope of the regression lines indicates the effect of the varying calibration levels. The closer the slope is to 1, the closer to linear the retroreflectometer measures markings of differing retroreflectivity levels.

When calibrated with a low retroreflectivity marking and then measuring a range of typical retroreflectivity markings, the mobile retroreflectometer is approximately 6 percent high. When calibrated with a medium retroreflectivity marking and then measuring a range of typical

retroreflectivity markings, the mobile retroreflectometer is approximately 2 percent low. When calibrated with a high retroreflectivity marking and then measuring a range of typical retroreflectivity markings, the mobile retroreflectometer is approximately 17 percent low. The results from this evaluation indicate that to achieve the best data, calibration should be conducted on a marking that has a relatively similar retroreflectivity value as those that are being measured.

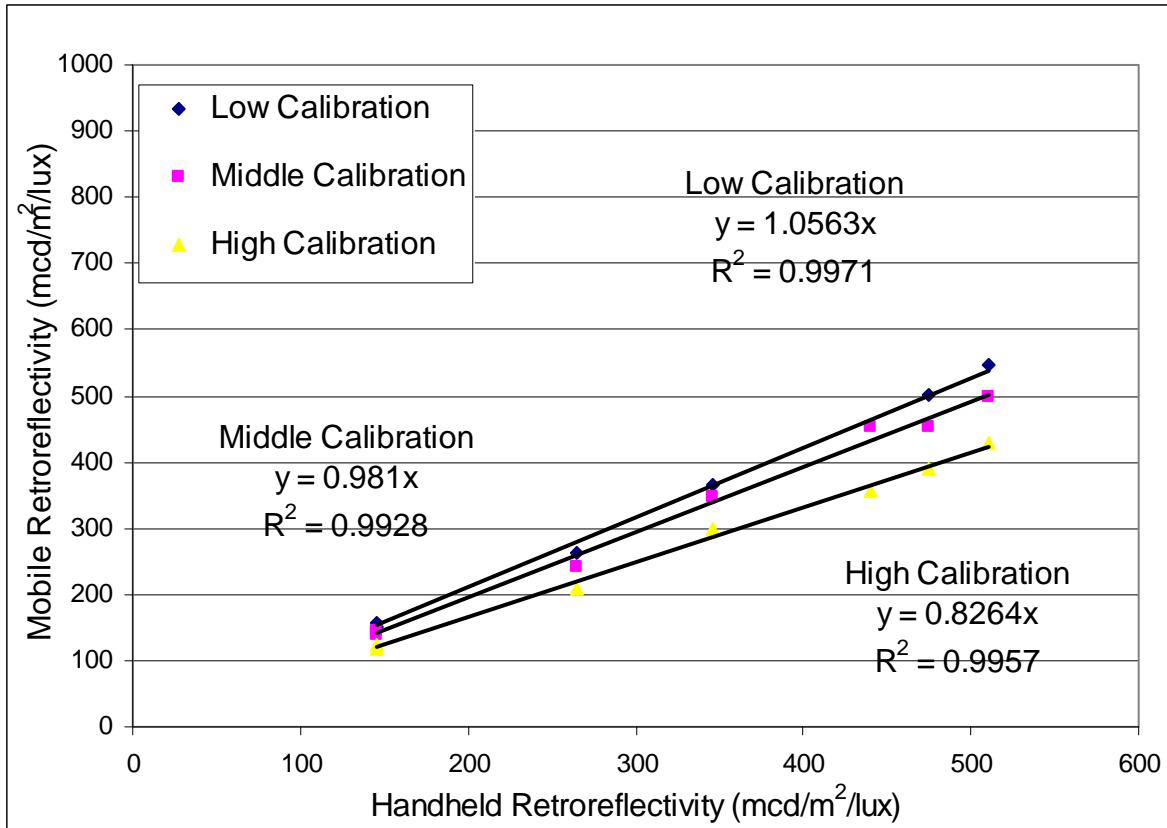

Figure 19. Linearity Testing.

5.0.2 Dynamic Testing

The researchers conducted dynamic testing of the mobile retroreflectometer on State Highway 21 (SH21) and State Highway 47 (SH47) in Bryan, TX. The mobile retroreflectometer was mounted to the vehicle as it would normally be for data collection. Dynamic testing was conducted at highway speeds unless otherwise noted. Though not ideal for isolating variables, dynamic testing was the only means to evaluate some of the sources of possible variation.

5.0.2.1 Acquisition Rate

The researchers conducted evaluation of acquisition rate, the distance over which the mobile retroreflectivity data are averaged in the software. The software has the ability to average data over a distance as short as 0.005 miles up to any length entered. The acquisition rate data were collected on 2-mile long section of SH21. This road was selected because it had a 2-mile long section of straight roadway with a continuous edgeline to collect data on. The acquisition rate data were collected in a loop on each side of the road. There are two values for each acquisition rate, one corresponding to the average of all readings in each direction. Prior to each run, the acquisition rate was set to the desired level and then the entire 4-mile loop was measured with the data collection vehicle traveling at approximately 65 miles per hour. Table 19 displays the results from the acquisition rate testing.

Table 19. Acquisition Frequency Testing.

Acquire Frequency	Westbound			Eastbound		
	N	Avg	StDev	N	Avg	StDev
0.01 mi	1698	325	26.8	1750	321	32.1
0.025 mi	1759	350	37.8	1614	309	32.8
0.05 mi	1546	323	39.7	1554	298	32.2
0.1 mi	1498	323	47.7	1519	303	36.5
0.25 mi	1458	338	33.8	1440	307	38.2
0.5 mi	1406	344	38.9	1351	318	43.3
1.0 mi	1245	338	37.1	1275	313	36.1

The values indicated are the average value for all the readings in the section. The shorter acquisition rates had more segments within the 2-mile long section whereas the 1-mile acquisition rate only had two segments along each 2-mile long stretch of road. The results from the seven different acquisition rates did not produce a consistent trend or any average values that could be considered practically different. The standard measurement acquisition rate is 0.1 miles, and none of the readings varied greatly from this value indicating that acquisition rate has little impact on the overall results. The average standard deviation was not consistently impacted by the acquisition rate either. It should also be noted that it seems that fewer readings are collected when the acquire frequency is longer. The researchers were unable to determine why fewer data points were collected, as data collection speeds were similar. The major impact of using a longer acquire frequency is that the data are not as detailed, because they are averaged

over a longer length. The use of a shorter acquisition length allows for a more detailed look at the retroreflectivity along the marking for a given length. The results of this testing indicate that a shorter acquisition rate will yield a very similar average retroreflectivity to a longer acquisition rate.

5.0.2.2 Data Collection Speed

The researchers conducted evaluation of measurement speed (vehicle speed) to evaluate the effect of changing speeds. The researchers conducted the speed testing on a 1-mile long section of SH47. This road was selected because it had a continuous solid edgeline to measure along the 1-mile section. This section also has a relatively low traffic volume; therefore our data collection would be less likely to impede traffic (70 mph posted speed limit) causing a safety concern.

The measurement speed data were collected in a loop on each side of the road so there are two values for each speed. Two loops were made for each speed and the values were averaged. Prior to each run, the cruise control was set to the desired speed and it was maintained through the test section. [Table 20](#) displays the results from the measurement speed testing. There were no practical differences in the average retroreflectivity values at the different speeds. The difference between the different speeds was that at higher speeds less data are collected. Since the mobile retroreflectometer collects so much data, the reduced number of data points had little impact on the average readings or the standard deviation.

Table 20. Speed of Data Collection Testing.

Speed (mph)	Southbound			Northbound		
	N	Avg	StDev	N	Avg	StDev
35	730	263	28.6	523	263	31.6
50	494	269	28.1	378	264	34.3
65	389	270	30.3	300	257	31.5
All	538	267	29	400	261	32

Since two runs were made at each speed, the repeatability of the data was also evaluated. The maximum difference between two runs at the same speed and in the same direction was less than 6 percent and the average difference for the six speed/section combinations was just over 3 percent. This indicates a good repeatability of the mobile retroreflectometer over our test sections.

5.0.2.3 Double Line Data Collection

The researchers conducted an evaluation of the comparison between the data collected on double yellow centerlines. The goal of this evaluation was to determine if the retroreflectometer was able to measure both markings the same number of times. Questions have been brought up in the past that the number of right data points were much less than the number of left data points. To determine the impact on the number of data points when measuring a double yellow centerline, the researchers measured seven sets of double yellow lines that were straight. The straight markings allowed the researcher to make sure that they were evenly measuring both markings the entire length of the line. The lines measured were each approximately half a mile long.

Table 21 displays the results of the double line evaluation. The data indicate that the number of right data points is always less than the number of left data points. One of the reasons for this is that the retroreflectometer software defaults readings to the left unless it sees two lines. There are times when measuring a double line that the retroreflectometer only picks up one of the lines with its scan and thus it gets read as a left point. The percent right point's column indicates the percent ratio of right points compared to left points. Most of the percentages are around 90 percent or higher. Line 4 had 77 percent the number of right points as it did left. The researchers think that the higher standard deviation of the right line, along with the retroreflectivity not being high, may have contributed to the lower number of right readings because the retroreflectometer may not have picked up both lines on every scan of the laser.

Table 21. Individual Trials on Several Lines.

Line	Left Points	Left Avg	Left StDev	Right Points	Right Avg	Right StDev	Percent Right Points
1	712	286	61	625	309	49	88
2	481	273	53	466	351	65	97
3	824	141	47	756	151	49	92
4	734	174	43	567	182	58	77
5	518	173	30	504	163	34	97
6	612	198	43	547	189	40	89
7	547	182	38	496	186	30	91

Based on the results of the individual line trial, the researchers attempted to further understand how the retroreflectometer reads double lines. The researchers measured a double

line that had good retroreflectivity on the left line and lower retroreflectivity on the right line. This line was measured three times to test the repeatability of the readings. Table 22 provides the results of the three runs. All three trials had a similar number of points and similar retroreflectivities of both lines. Comparing the number of left points to right points, there are approximately 70 percent the number of right points as compared to the left. This result was similar to Line 4 from Table 21. The researchers attribute this difference to the high retroreflectivity of the left line and the lower retroreflectivity of the right line. The high retroreflectivity will almost always get read as a left point, whereas the lower retroreflectivity line will have more times when the line is not read, resulting in fewer points.

Table 22. Multiple Trials on Same Double Line.

Trial	Left Points	Left Avg	Left StDev	Right Points	Right Avg	Right StDev
1	733	283	40	535	148	15
2	737	277	37	493	143	14
3	732	277	37	508	146	14
Avg	734	279	38	512	146	14

In addition to retroreflectivity and standard deviation differences between the lines accounting for a difference in the number of data points, there are two other factors not associated with the retroreflectometer that will contribute to a difference. These factors are vehicle wander and roadway geometry. The retroreflectometer has a scan width of approximately 1.1 meters that can help compensate for vehicle wander, but often times the vehicle will wander far enough away that it will not read both line at the same time. When the data collection vehicle wanders and only one of the lines are read, it is defaulted to the left position. The horizontal roadway geometry also plays a factor in that left and right curves make it more difficult to stay on the marking, especially since the retroreflectometer measures 10 meters out in front of the vehicle. The number of right data points is affected by the ability of the driver to keep both lines in the measurement window and the ability of the retroreflectometer to pickup both lines with each of its measurement scans. Data showing only 75 percent as many right points as left are not unrealistic, and depending on road conditions as few as 50 percent right points are not totally unreasonable for some segments.

5.0.2.4 Signal to Noise Ratio

The researchers conducted an evaluation of the signal to noise ratio to determine its effect and what may be an appropriate level to set it at. The signal to noise ratio (SNR) is a user-entered value in the retroreflectometer software that determines what the software measures as the minimum acceptable retroreflectivity value. The software considers the SNR value and the background noise the retroreflectometer is reading to determine the minimum values it will accept. An SNR value that is too low will allow too many low false retroreflectivity readings that can be attributed to road noise. An SNR value that is too high can possibly throw out actual retroreflectivity values of the marking being measured.

The SNR testing was conducted on a mile-long section of SH47 southbound edgeline. Three passes were conducted on the mile long section at each of the five SNR values. [Table 23](#) provides the results of each pass. [Table 24](#) provides the average value at each SNR. [Table 23](#) indicates that the repeatability of the retroreflectometer is good. [Table 24](#) provides an indication of the impact of the SNR value on the average data. As the SNR value is raised, the average retroreflectivity value increases and the standard deviation decreases. This is due to the software not accepting as many low data points from the background road noise. As the SNR increase, it will get to a point where it is only accepting valid retroreflectivity readings that are from the pavement marking. For the marking that was measured, an SNR value of 3 to 3.5 was acceptable. For lower retroreflectivity pavement markings, a lower SNR value may be needed to ensure that all the pavement marking retroreflectivity values are accepted.

Table 23. All Signal to Noise Ratio Trials.

Trial	SNR Value	Average Retroreflectivity	Average StDev
1	1.5	141	55
2	1.5	143	55
3	1.5	145	56
1	2	149	50
2	2	153	45
3	2	149	44
1	2.5	163	39
2	2.5	157	34
3	2.5	156	36
1	3	167	43
2	3	163	39
3	3	162	38
1	3.5	166	35
2	3.5	164	38
3	3.5	168	34

Table 24. Signal to Noise Ratio Average Values.

SNR	Average Retroreflectivity	Average StDev
1.5	143	55
2	150	46
2.5	159	36
3	164	40
3.5	166	35

5.0.3 Combined Static and Dynamic Testing

The combined static and dynamic testing was performed on variables that were best evaluated in both conditions. The data were collected in the same manner as the individual static and dynamic data collections.

5.0.3.1 Measurement Position

The researchers evaluated the effect that the measurement position has on the retroreflectivity value. This testing was conducted in two phases; phase 1 was without compensation, and phase 2 was with the compensation. The mobile retroreflectometers software has a user adjustable compensation to correct for retroreflectivity differences across the measurement window. After the first phase of testing, the compensation was adjusted to best fit the retroreflectometers profile. The static measurement position testing was conducted with the

mobile retroreflector mounted on both sides of the vehicle since the alignment of the system was found to be slightly different on each side. The researchers conducted the dynamic testing with the retroreflector mounted only on the right side of the vehicle.

When the retroreflector is mounted on the left side of the vehicle, the center of the measurement is at position 80, whereas on the right side it is at position 100. This is a situation that is unique to the research team's data collection vehicle due to the mounting brackets that connect to the vehicle being slightly different. Static measurements on the left side were taken at positions 20, 50, 80, 110, and 140. Static measurements off the right side were taken at positions 20, 60, 100, 140, and 180. To take the measurements at each location, the pavement marking sample was moved to the position and centered on the laser. The laser was not moved during the testing. [Figure 20](#) (right side data) and [Figure 21](#) (left side data) provide the results of both phases of testing. [Figure 22](#) provides an indication as to the difference in alignment and a reason for the sharper drop off in the right half of the measurement when positioned on the left side. The arc of the laser scan is symmetric when mounted on the right side (figure inset), but when mounted on the left it is more of a check mark shape. This check mark shape is the result of the base plate that the retroreflector mounts to not being perfectly level. The outside portion of the plate sits slightly lower than the inside portion causing the left part of the laser to hit the ground earlier than the right side. This check mark causes a greater drop off on the right hand side of the measurement since the laser is further away than it would be if it were symmetric. Overall on both sides as the measurement location moves away from the center the retroreflectivity decreases. This is caused in part due to the laser being further away producing a lower retroreflectivity level (see measurement geometry section), and the measurement being more offset reducing the signal. With this knowledge of the retroreflectivity levels across the measurement window, the compensation was set to try and adjust the values.

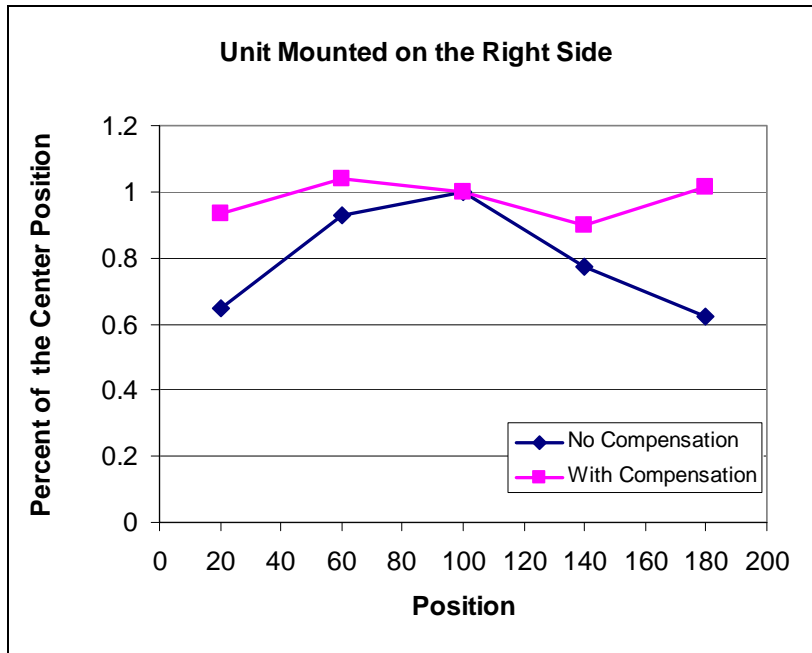

Figure 20. Right Side Static Position Testing.

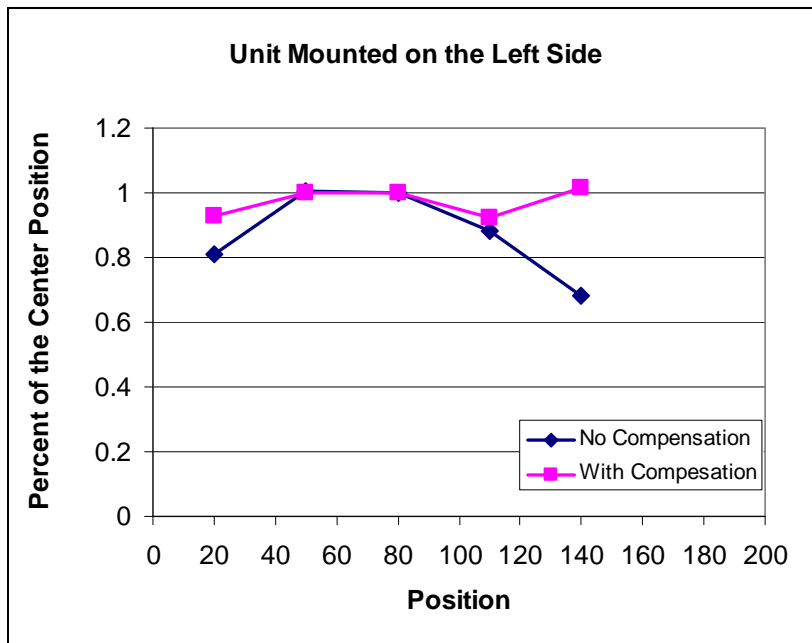

Figure 21. Left Side Static Position Testing.

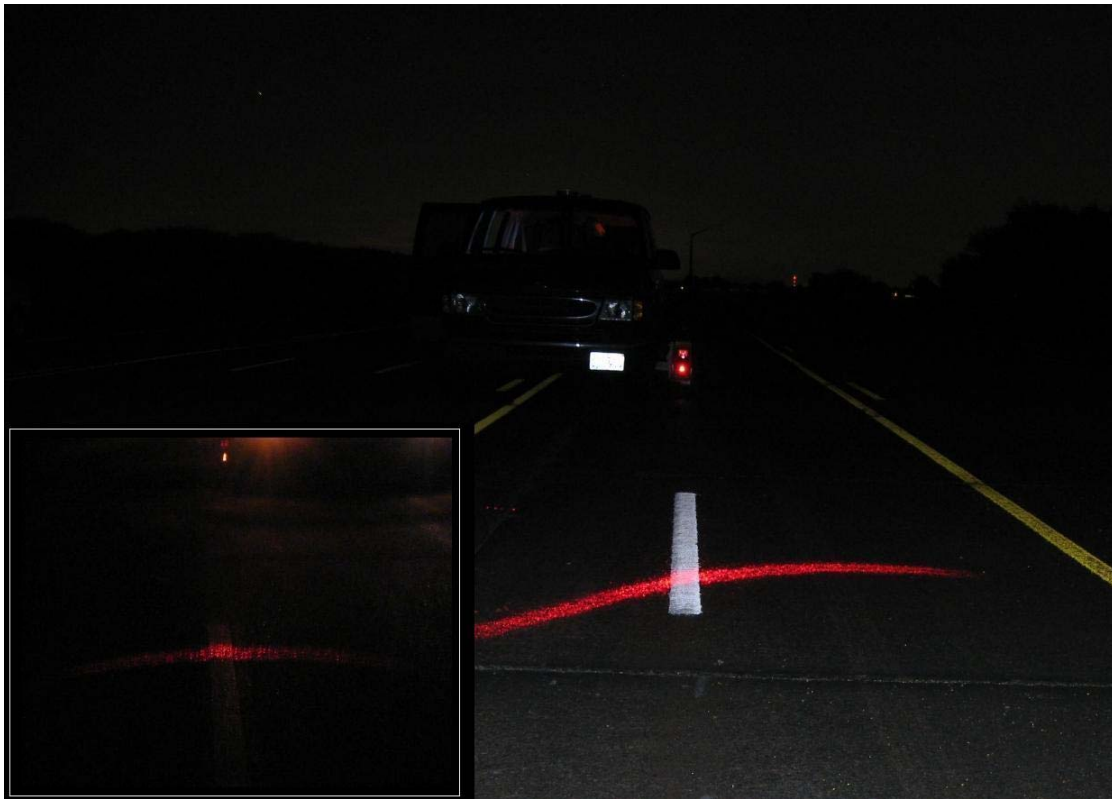

Figure 22. Visual of the Laser Pattern.

With no compensation correction and the retroreflectometer mounted on the right side, the outside measurements were 65 percent and 62 percent of the center measurement. With compensation they were 94 percent and 101 percent of the center measurement. With no compensation correction and the retroreflectometer mounted on the left side, the outside measurements were 81 percent and 68 percent of the center measurement. With compensation they were 93 percent and 101 percent of the center measurement. The evaluation clearly shows a significant impact on the retroreflectivity reading as the location moves away from the center. The compensation provided by the software provides much more accurate data across the measurement window.

A second evaluation of the static measurement position testing was conducted approximately nine months after the initial evaluation. The second evaluation tested to see if there were any changes to the alignment of the system. The second evaluation results were nearly identical to the first evaluation with and without the compensation.

In addition to the static testing, a dynamic test was also conducted to see how the retroreflector data differ across the measurement window when collecting data. The researchers collected data on a mile-long segment of SH47 edgeline. The data were collected while driving down the road so the measurement position was not always at the exact location that is indicated, but the data were collected as close to the indicated position as possible. Data were collected near the center position, near measurement position 150, and near measurement position 50.

The researchers summarized the dynamic data like the static data, comparing the outside measurements to the center position. [Figure 23](#) indicates the results of the testing with and without compensation. The retroreflector behaved differently in the dynamic test from the static test. The dynamic measurements made near position 50 were approximately 8 percent higher than the center position without compensation, whereas during the static testing they were around 10 percent lower. The dynamic measurements made near position 150 were approximately 55 percent lower than the center position without compensation, whereas during the static testing they were approximately 25 percent lower. The change in percent difference required the adjustment of the compensation to properly account for the changes. Even with the changes, like the static testing the compensation greatly increases the accuracy of the retroreflector. The researchers believe that the difference between the static and dynamic tests is due to the weight distribution in the vehicle during the dynamic testing. The static testing did not have any people in the vehicle whereas the dynamic test did. This could influence the pattern of the laser as was seen when comparing the right and left side during the static testing. Either way though with proper testing the measurement position compensation provides for much more accurate data across the measurement window. Even with the assistance of the position compensation the goal should be to maintain a consistent position on the line near the center of the measurement window.

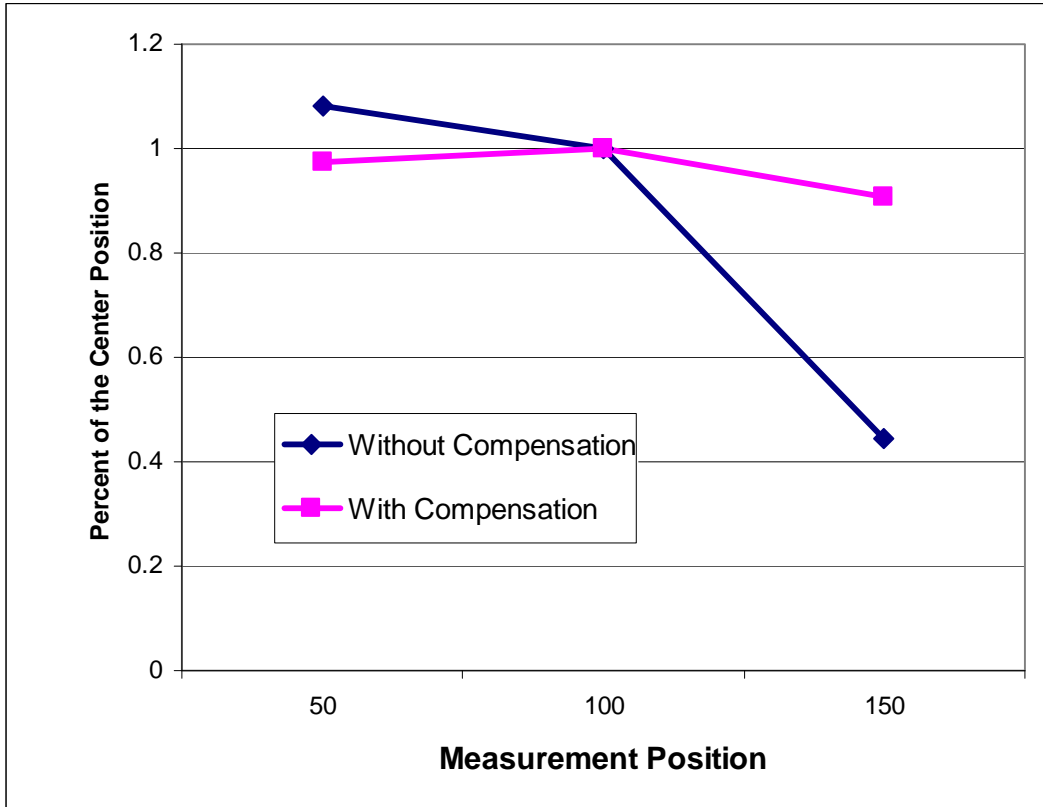

Figure 23. Dynamic Position Testing.

5.0.3.2 Nighttime Data Collection

The researchers conducted several night tests of the mobile retroreflectometer to evaluate the effect of external light sources on the accuracy of the mobile retroreflectivity data. Both static and dynamic tests were performed to determine the effects of opposing vehicles, vehicles going the same direction, and overhead lighting. The dynamic overhead lighting test was conducted on SH47 along a mile-long stretch that had continuous overhead lighting along the last half. The static testing was conducted outdoors at the TTI/TxDOT mobile retroreflectivity certification course.

Overhead lighting was evaluated by measuring the section of road with handheld retroreflectometers during the day to determine the retroreflectivity of the marking along both the lit and unlit sections. That night mobile retroreflectivity readings of the marking were collected by driving through the lit and unlit sections five times each. [Table 25](#) provides the results of the overhead lighting testing. The retroreflectivity in the two sections was slightly different so the handheld and mobile data were adjusted in the second section so that the

handheld values would be the same. This makes for an easier comparison between the mobile values in the two sections. The handheld and mobile values were within 10 percent in each section, but more importantly for this testing is that the mobile values in the unlit area and in the lit area differed by less than 1 percent. This would indicate a minimal impact from the overhead lighting.

Table 25. Dynamic Overhead Lighting Testing.

Overhead Lighting Test		
Measurement Condition	Average Retroreflectivity	
	No Lighting	With Overhead Lighting
Handheld	260	260
Mobile Trial 1	236	237
Mobile Trial 2	232	237
Mobile Trial 3	243	239
Mobile Trial 4	236	238
Mobile Trial 5	231	236
Average Mobile Trial	235	237

To evaluate the effect of oncoming vehicles at night when measuring yellow centerline markings, the mobile retroreflectometer was mounted on the left side of the vehicle. The mobile retroreflectometer was aimed at a marking, and a vehicle was positioned in the opposite lane and left stationary facing the mobile retroreflectometer. [Figure 24](#) shows the setup for the left side testing. The first test was to evaluate the effect of calibrating with the measurement vehicle lights on or off. The second and third tests were conducted with the measurement vehicle lights on low and with the opposing vehicles lights on. The vehicles placed in the opposing lane had differing headlights. One vehicle had halogen headlights whereas the other had xenon headlights. [Table 26](#) shows the results of the left side testing. There is a more noticeable effect between measurement vehicle lights off and measurement vehicle lights on than there is with adding opposing vehicle lights. This would indicate that calibrating with the measurement vehicle lights on is the best way to get an accurate calibration when calibrating at night. The effect of the opposing vehicle headlights was about 1 percent, which is not a significant or practical difference.

The mobile retroreflectometer was also mounted on the right side of the vehicle to evaluate the effect of oncoming vehicles and same direction vehicles at night when measuring

white pavement markings. The mobile retroreflector was aimed at a marking, and a vehicle was positioned in the opposite lane facing the retroreflector or adjacent to the mobile retroreflector facing the same direction and left stationary. The first tests were to evaluate the effect of calibrating with the measurement vehicle lights on or off. The second and third tests were conducted with the measurement vehicle lights on low and with the other vehicles lights on. [Table 26](#) shows the results of the right side testing. Again it can be seen that there is a noticeable effect between no measurement vehicle lights and measurement vehicle lights on. This would indicate that calibrating with the measurement vehicle lights on is the best way to get an accurate calibration when calibrating at night. The effect of the opposing vehicles headlights was about 5 percent and the adjacent vehicles headlights was about 2 percent. Neither difference was considered to be a practical difference.

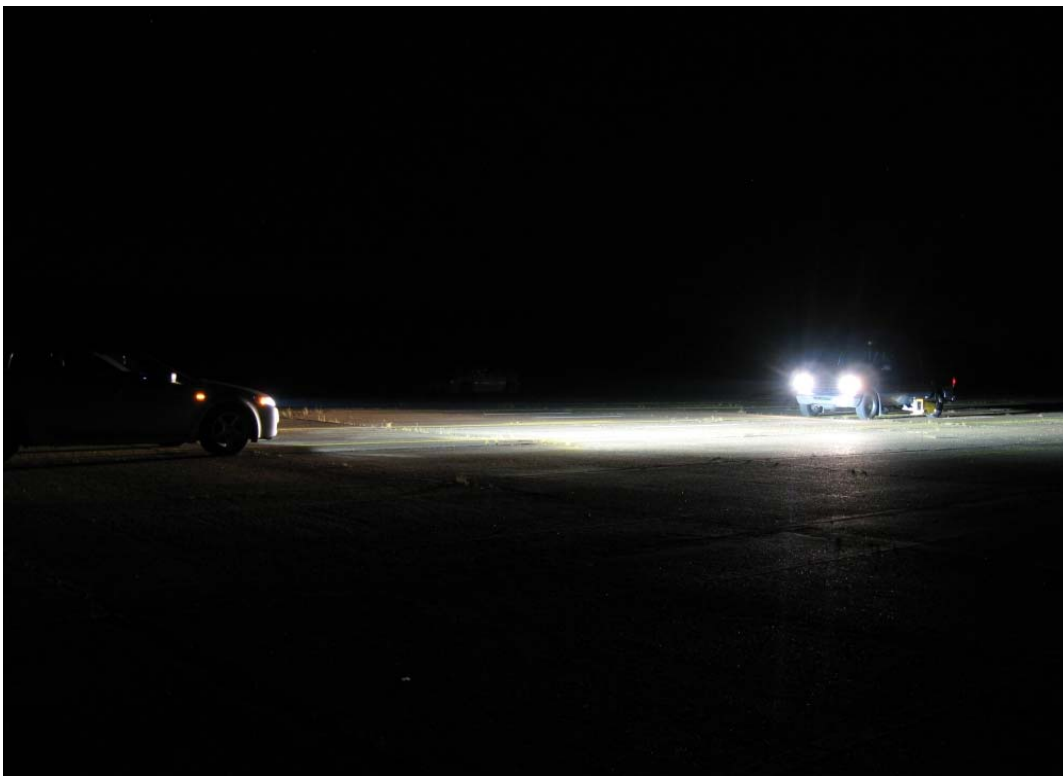

Figure 24. Nighttime Oncoming Vehicle Testing.

Table 26. Static Night Testing.

Mounted on Left Side of Van (Positioned for Measuring Yellow Marking)	
Measurement Condition	Average Retroreflectivity
No Van Lights	485
Just Van Lights (Low)	468
Car 1 Oncoming (Xenon headlamps)	470
Car 2 Oncoming (Halogen headlamps)	473
Mounted on Right Side of Van (Positioned for Measuring White Marking)	
Measurement Condition	Average Retroreflectivity
No Van Lights	503
Just Van Lights (High)	517
Just Van Lights (Low)	521
Car 1 Beside (Xenon headlamps)	509
Car 1 Oncoming (Xenon headlamps)	494

To further simulate measuring markings on the road at night when there is opposing traffic, the researchers left the measurement vehicle and mobile retroreflectometer in a stationary position and drove the two vehicles that were used in the static testing past the mobile retroreflectometer as if they were oncoming traffic. The test was conducted for 15 minutes with no traffic and then 15 minutes with the two vehicles continuously driving past the stationary retroreflectometer and marking that was being measured. Over the 15 minutes each vehicle made 30 passes at varying speeds. This resulted in a simulated traffic volume of approximately 11,000 vehicles per day. [Table 27](#) shows the results from the “simulated” oncoming traffic test. The results were similar to the left side testing, where opposing lights had a very little impact on the retroreflectivity level. The effect of the opposing lights was not practically different and for most roads, the nighttime traffic volumes will be less than what was simulated resulting in even less of an effect.

Table 27. Static/Dynamic Simulated Traffic Testing.

“Simulated” Traffic Testing	
Measurement Condition	Average Retroreflectivity
Without Traffic	354
With Traffic	350

5.0.4 Limitations to the Sensitivity Analysis of the Major Variables

This research attempted to evaluate the impact of several major variables on the accuracy of mobile retroreflectometer data. Even with the steps taken and the variables evaluated, there

are still limitations within the evaluation. Limitations of the evaluations and unexplored variables are described in this section.

The researchers conducted the evaluation of the variables in as controlled of an environment as possible to reduce the influence of other variables, so that the variable being evaluated was the only one influencing the retroreflectometer. Though every attempt was made to reduce variables other than those being tested at the time, other variables may have affected the results. Due to the researcher's inability to perfectly isolate the variable being evaluated, the impact of other variables is a limiting factor in the evaluations.

As previously mentioned, pavement markings are inherently variable due to variability along the pavement marking. Small movements of a retroreflectometer along a marking will yield differing retroreflectivity results. The researchers attempted to measure the marking in similar locations and to select markings that had a small variation along their length to minimize the natural marking variability as much as possible. Even minimizing the variability, it still exists and can influence the results.

The temperature evaluation was limited in respect to the range of temperatures evaluated. The temperatures evaluated ranged from 25 to 45 degrees Celsius. Operating temperatures during the winter in Texas will often be as low as 15-20 degrees Celsius, and summer operating temperatures may get close to 50 degree Celsius. Further analysis of the temperature effects and compensation effects at the ends of the temperature range should be conducted. The researchers expect that the compensation algorithm will provide good correction to the retroreflectivity values as long as the correction factors are the proper value.

The double line evaluation compared readings on straight lines. Many double yellow situations occur on roadway segments with horizontal curvature. An evaluation of the true impact on measurements around curves is necessary to determine the impact on the number of data points on both the right and left line and to evaluate the impact of the vehicle body roll on the retroreflectivity readings. The impact of body roll and the number of right and left points will be vehicle and driver specific.

The signal to noise ratio was tested for a low retroreflectivity marking, but the marking still had an adequate level of retroreflectivity. SNR testing on very low retroreflectivity lines and on various surface types may be necessary to determine the best SNR values to use on low retroreflectivity markings with varying background noise conditions. Also the evaluation of

SNR on lane lines may provide some additional insight into the effect of SNR on the retroreflectivity data collection.

The measurement position evaluation appears to be different when measuring in a static and dynamic condition. The measurement position evaluation also appears to be different on each side of the vehicle. Dynamic testing on both sides of the vehicle is necessary to ensure that the correct compensation values are used when the retroreflectometer is positioned on each side of the vehicle. The measurement position evaluations will be unique to each vehicle setup.

The night testing evaluation was limited to simulated traffic to reduce the impact of other variables that were difficult to measure. A night evaluation in actual traffic on a representative roadway and daytime collection in the same area could provide a better idea of the impact of collecting retroreflectivity data at night. Along the same lines as the night testing, the impact of measurements made in sunny versus measurements made in cloudy conditions is an area where evaluation is necessary. The ability to quantify and control sunlight conditions makes this evaluation difficult and may limit the repeatability of the evaluation.

The reproducibility of the variable evaluations and collected data were impossible to evaluate as only one retroreflectometer was available for testing. Many variables are retroreflectometer and/or vehicle specific, therefore specific testing should be conducted on each mobile retroreflectometer and vehicle setup. Testing of all vehicles and their retroreflectometers is the only way to ensure that the impact of the variables is properly accounted for either by compensation or data collection techniques.

5.1 OPERATIONAL BEST PRACTICES

The researcher's second effort under the mobile retroreflectometer evaluation is documenting the best practices with regards to the operation of the mobile retroreflectometer. The lessons learned while collecting data during the variable evaluations and data collection under real world conditions provide the basis for the best practice recommendations. This documentation of best practices will be most useful to TxDOT staff and contractors using mobile retroreflectometers and could potentially be used to develop specifications for retroreflectivity data collection contracts. A separate deliverable 0-5656-P1 (50) will document all the best practices with regards to mobile retroreflectometers; this section will only outline the operational

best practices. The operational best practices are described in separate deliverable in the following order:

- Equipment,
 - Mobile Vehicle,
 - Mobile Retroreflectometer,
 - Handheld Retroreflectometer,
- Setup and Calibration,
 - Measurement Geometry,
 - Calibration Panel,
 - Measurement Linearity,
 - Calibration,
 - Calibration/Dynamic Check,
- Accounting for Measurement Variables,
 - General Software Setup,
 - Data Collection Speed,
 - Data Collection Acquire Frequency,
 - Signal to Noise Ratio and RRPM Level,
 - Unit Operating Temperature,
 - Measurement Position,
 - Double Line Data Collection,
 - Nighttime Data Collection,
- Equipment Testing, and
 - Compensation Testing.

5.2 DEVELOPING A DECISION MODEL FOR MANAGING PAVEMENT MARKING REPLACEMENT

5.2.1 Introduction

Logic and experience suggest that degradation in retroreflectivity of pavement markings is a result of the age of the marking and wear caused by vehicle tires. There are other factors that potentially influence the variability of the degradation process such as initial marking quality, application techniques, bead systems used, road surface type, marking location, and climate. In

order to develop a model that would allow maintenance personnel to predict the point at which a length of pavement marking should be replaced, it is necessary to examine the relationship between age and tire wear and to examine the influence of other factors.

In the stylized depiction of the predictive model presented in Figure 25, as age and volume increase, retroreflectivity decreases. The red line represents a threshold of acceptable retroreflectivity, thought to be about 100 mcd/m²/lux. Retroreflectivity values above this line would be less than 100 mcd/m²/lux and those below the threshold line would be greater. The actual location of the red line is dependent on all the variables that impact the retroreflectivity of the pavement markings. Until collection of large volumes of data on roads in a given area, the location of the red line should be based on experience and expectations.

Figure 25 also shows a dashed orange line that parallels the red threshold line. This line represents a subjective value that might be used to trigger planning for measurements and/or to schedule restriping jobs before the threshold of degradation is reached. Such a model would allow a means of deciding when retroreflectivity measurements would need to be taken to confirm the need to replace a section of pavement marking, and/or an approximation of when markings should be restriped.

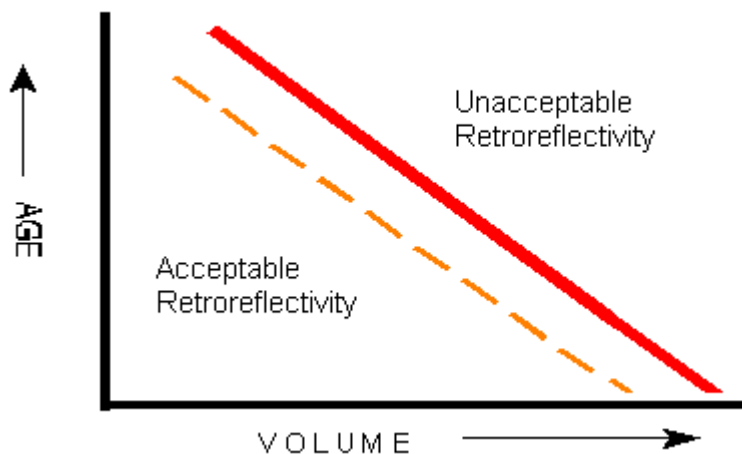

Figure 25. Predictive Retroreflectivity Model Based on Marking Age and Traffic Volume.

5.2.2 Objective

The objective of this process is to develop regression models of the influence of age and tire wear on the retroreflectivity of pavement markings. Should data for other independent

variables be conveniently available, these factors will be considered for inclusion in the regression models developed.

5.2.3 Method

District information files will be used to develop a list of potential segments of pavement markings to be measured for the development of regression models. At a minimum, the information required for potential selection of a segment will be age of the pavement marking and per lane volume for the roadway on which the marking is installed. If information concerning marking type, function, and roadway type are available, these data will be collected as well (see the discussion below).

5.2.3.1 Independent Variables.

The primary variables of interest include:

1. Age – four bins of ages will be used.
 - a. 1 to <3 years,
 - b. 3 to <5 years,
 - c. 5 to <7 years, and
 - d. greater than 7 years.
2. Volume – five bins of volumes will be used.
 - a. less than 2 thousand vehicles per lane,
 - b. 2 to <4 thousand vehicles per lane,
 - c. 4 to <6 thousand vehicles per lane,
 - d. 6 to <8 thousand vehicles per lane, and
 - e. greater than 10 thousand vehicles per lane.

If available, the following will be collected:

3. Type of Marking – four types will be considered.
 - a. thermoplastic,
 - b. paint,
 - c. tape, and
 - d. epoxy/polyurea.
4. Marking Function – three types of functions will be considered.
 - a. edge marking,

- b. centerline, and
 - c. lane line marking.
5. Pavement Type – three types of pavement will be considered.
- a. concrete,
 - b. asphalt, and
 - c. seal coat.
6. Pavement Area Function – three types of areas will be considered.
- a. tangent sections,
 - b. horizontal curve sections, and
 - c. weaving sections.

5.2.3.2 Dependent Variable

The dependent variable will be the retroreflectivity of 0.1-mile segments of pavement markings as measured by a mobile retroreflectometer. The average of multiple retroreflectivity readings will be used to represent the retroreflectivity of the entire segment.

5.3.3.3 Sample Size

The levels of the age and volume independent variables form a 4x5 matrix of twenty cells. A sample of average retroreflectivity measurements for five, 0.1-mile segments of pavement marking will be taken for each of these cells. This sample of 100 measurements would be taken for one level of each of the other independent variables. Thus, the 100 measurements of 0.1-mile segments would need to be replicated for each level of marking type, marking function, pavement type, and pavement area function.

5.2.4 Suggested Sampling Plan Methodology

Due to limited resources it may be necessary to only collect retroreflectivity data on a limited number of roadways. Several steps to reduce the quantity of the data collection are available. It is the general premise to reduce the quantity of roads to be measured based upon expectations of the quality of the markings and planned use of the resulting retroreflectivity data. Additional factors to reduce the data collection in a given district are based on roadways that meet the following criteria. Data on these roadways do not need to be collected for replacement of the marking purposes, but should be collected if degradation modeling is an objective:

- newly striped roadways (less than 12 months old, or longer for low ADT roads),
- roads that are to be resurfaced within the next year,
- roads where the markings receive a visual score of good or excellent, and
- roads where the modeled retroreflectivity fall well within the acceptable levels.

5.2.5 Procedure

In order to assess the feasibility of obtaining the necessary data and to test the significance of the regression model methodology, the initial data collection effort should be concentrated on obtaining retroreflectivity measurements for a single type of pavement marking, performing one function on a single type of pavement. For example, the 4x5 age/volume cells should be populated with retroreflectivity measurements taken for 100, 0.1-mile segments of thermoplastic centerline marking on asphalt pavement.

5.2.6 Analysis and Results

Once the initial data are collected, a multiple regression model can be developed that describes the relationship between age and volume for a particular type of pavement marking, performing a specific function on one type of pavement. If the age and volume independent variables account for a significant portion of the variation in the retroreflectivity values of the dependent variable, then the process can be replicated for the other levels of the independent variable.

While it is possible to combine all levels of all independent variables into a single multiple regression model, it might be difficult to obtain data to fill all of the cells required. Further, it is preferable to validate the procedure and the methodology with a smaller, more manageable study before proceeding.

CHAPTER 6. PAVEMENT MARKING MANAGEMENT SYSTEM BEST PRACTICES

6.0 INTRODUCTION

Retroreflectivity data can be used to determine if the markings are meeting minimum installed retroreflectivity levels or minimum maintained retroreflectivity levels. The retroreflectivity data can also be used to prioritize roads for restriping based on measured retroreflectivity levels. Based on input from TxDOT staff, a variety of display mechanisms would be useful for displaying the resulting data from mobile retroreflectivity data collection. Mapping and graphing the data can be useful tools for visualizing the markings' retroreflectivity level. Mapping data from numerous roads can provide a view of the overall quality of the pavement markings. The data can also simply be viewed in spreadsheet format and analyzed as described in the previous section. Roadways could then be rank-ordered based on retroreflectivity averages and any other criteria, such as roadway classification or ADT, and striping plans could then be prioritized based on the retroreflectivity summary list. The retroreflectivity data can also be used with previous data to create degradation curves for the markings in an effort to better estimate the expected life of the markings in various conditions.

Color-coded sections on a map can display retroreflectivity data based on retroreflectivity level. Color coding could be as follows: adequate (above 150 mcd/m²/lux), needing attention in the near future (100 mcd/m²/lux to 150 mcd/m²/lux), and needing replacement (below 100 mcd/m²/lux). These maps would provide a quick, clear view of what areas need the most attention and overall pavement marking conditions. The color coding and retroreflectivity levels can be adjusted to include different and/or more/fewer levels.

A common problem with mobile retroreflectivity data is the quantity of data that can be captured and the number of associated data files. Increasing the acquire frequency to a longer length will decrease the number of individual data points on a road but will not reduce the number of files, and the increased length decreases the ability to look at small segments. Tools are needed for processing, viewing, analyzing, and displaying the retroreflectivity information. Tools to manage the data and extract the desired results from the data are the key to creating useful information from large amounts of data. The following sections outline processes and prototype tools to aid in these efforts. More sophisticated analyses and linkages to other TxDOT

databases will be beneficial to provide decision makers with the ability to make informed decisions and better manage the states' pavement marking assets.

6.1 RETROREFLECTIVITY DATA FILE HEADERS

The current version of the Laserlux® software does not contain any fixed fields that will enable ease of automation. Nor does the software contain a menu system to allow the user to enter various preloaded roadway and marking information. To automate the processing of data files, some information is needed about the file on the road segment on which the data are being collected. [Figure 26](#) shows a prototype menu-driven application that will enable the labeling of data files. This prototype allows users to put data files in a directory and then systematically label those files. Ideally, the user would complete this process at the end of the day when routes and details are fresh in their memory.

A TxDOT district office will typically select a sample of roads to be measured with most of the roadway, section, and marking information available. In addition to the roadway descriptive elements, the TxDOT control section milepost, Texas Reference Marker number, and other terminology will typically be with these data. A standard spreadsheet format that would feed the menu system is assumed and/or could be easily developed. Pull-down menus provide consistent spelling, naming, etc. Once the file has consistent header information, the ability to batch process an unlimited number of files is possible.

Retro File Name <input type="text"/>		
Retro ID <input type="text"/>	Key Map <input type="text"/>	
Road Name <input type="text"/>	Road Type <input type="text"/>	Lane Number <input type="text"/>
Limits <input type="text"/>	Direction of Travel <input type="text"/>	Section Length <input type="text"/>
Marking Type <input type="text"/>	Marking Color <input type="text"/>	Material Type <input type="text"/>
Pavement Type <input type="text"/>	Pavement Conditon <input type="text"/>	Weather <input type="text"/>

Figure 26. Prototype Menu Driven Retroreflectivity Data File Header Input Screen.

The attributes that are labeled are as follows with examples given:

- Roadway Name (Katy Freeway, TxDOT Name- IH0010);
- Roadway Type (Main Lanes, Frontage Road, Arterial, etc.);
- Roadway Lane Number (what lane is being measured);
- Travel Direction (NB, SB, EB, WB);
- Section Limits (IH 610 to BW8);
- Section Length (6.21 miles);
- Marking Type (Edgeline, Centerline, Lane Line);
- Marking Color (Yellow or White);
- Type of Material if known (Thermoplastic, Tape, etc.);
- Pavement Type (Concrete, Asphalt, Seal Coat, etc.);
- Pavement Condition (wet, dry, dirty, etc.);
- Weather (sunny, overcast, night, etc.); and
- Other (other informational fields and or comments fields).

The envisioned automation process is outlined in [Figure 27](#). These steps consist of documenting the retroreflectivity data file, batching the retroreflectivity files together, and mapping the data using GIS. Once the retroreflectivity data is linked to the TxDOT roadway network, a vast array of analysis can be performed by linking to TxDOT databases such as the Pavement Management Information System. These procedures could also be developed for the handheld data files.

6.2 PROTOTYPE IN AUTOMATION

Once the header information is consistent, a number of quality assurance and quality control steps can be completed. In addition the files can be aggregated into a single file and or database that will allow more efficient access to the information. The process of gathering the files involves opening each file and pulling the data into a single file or database, associating the retroreflectivity data to the roadway link, marker type, color, etc. This process could also be done by linking tables in a relational database.

In addition to providing ease of access to the retroreflectivity data, using one file simplifies the GIS process that is described below. The process to pull the retroreflectivity files into GIS is fairly involved. However, batching or grouping the files limits the number times the

process is required to be performed. There are steps that could be run to automate the process further and as the process evolves these procedures and techniques will be refined.

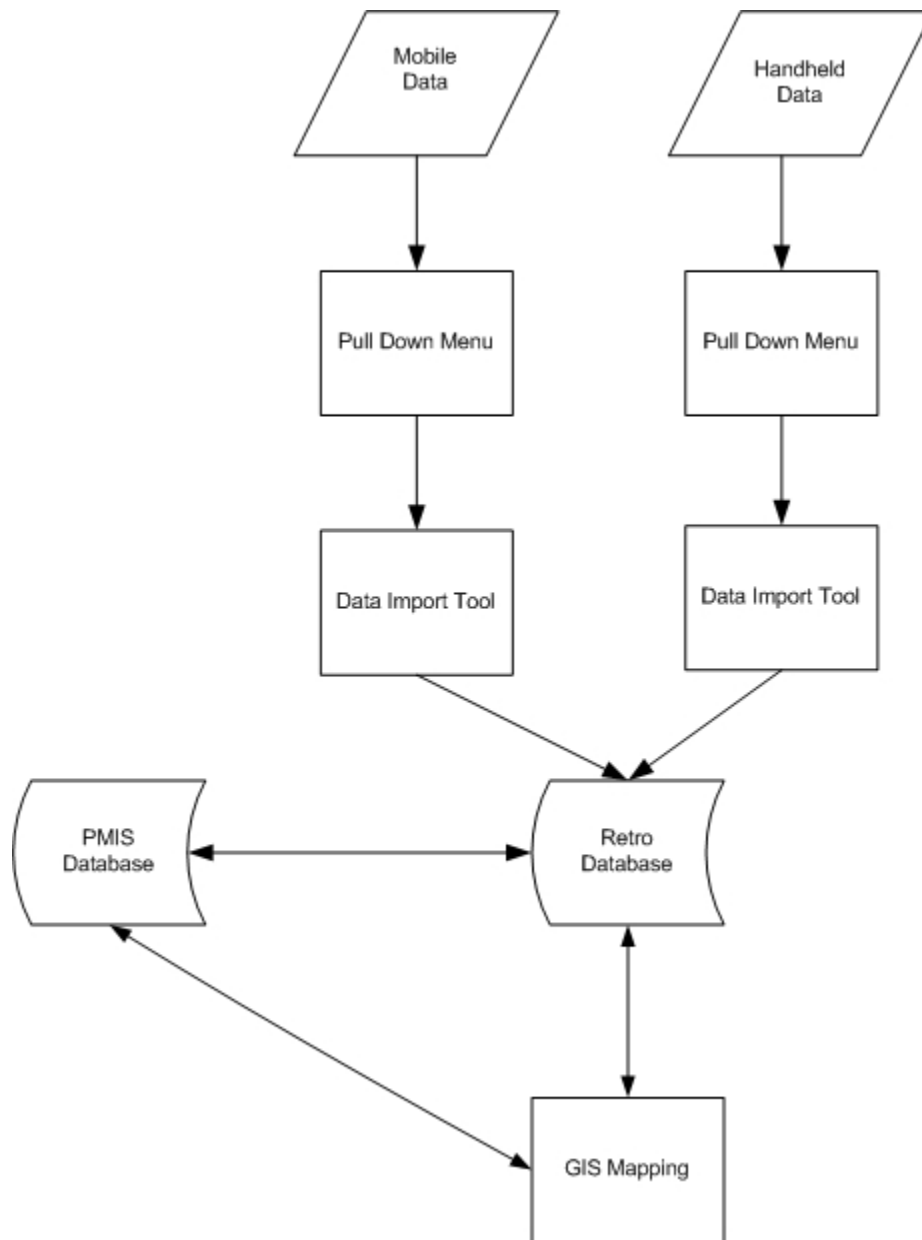

Figure 27. Flowchart Showing High Level of Automation.

6.3 GIS PROCEDURES

The following subsections provide procedures to import the retroreflectivity data files, plot the points on a GIS map, and link the data to the corresponding roadway sections.

6.3.1 Overview

Mapping of the retroreflectivity data is relatively straight forward but fairly involved. Moderate GIS and Spreadsheet experience is desirable. The process involves several steps in both GIS and Spreadsheet programs. These steps are listed below and described in detail later in the following section.

- Retroreflectivity Data File Preparation,
 - Adding columns,
 - Defining roadway name,
 - Removing degree symbol,
 - Adding offset distance,
 - Adding snap distance,
 - Format columns,
- Adding Retroreflectivity Points to GIS,
 - Set frame properties (select a coordinate system),
 - Add retroreflectivity points using XY data,
 - Assign a coordinate system,
 - Save points as a layer,
- Add the District DFO (Distance From Origin),
 - Add the features to your map,
 - Set the coordinate system,
- Locate Features Along a Route,
 - Use the ArcToolbox\Linier Referencing Tools\Locate Features Along a Routes,
- Add Column in Excel,
 - Add column for From DFO,
 - Rename column To DFO,
 - Copy data from ToDFO to column FromDFO and down one row,
 - Develop a latitude and longitude for the first segment,
- Make a Route Event Layer,
 - Use the ArcToolbox\Linier Referencing Tools\Make a Route Event Layer, and
 - Create or import symbology for layer.

6.3.2 What Is Needed

The following files and program add-ons are needed to perform the following procedures:

- District route map DFO (GIS data files),
- ArcView with the Linier Referencing features (add-ons loaded), and
- Retroreflectivity data files.

If data from more than one roadway type of a named road are being collected, these sections may need to be processed separately. For instance if you are collecting retroreflectivity data on the main lanes and on the frontage roads the data may need to be run separately or offsets on the display will need to be large enough otherwise the points or lines will plot on top of each other.

Quality Assurance Quality Control

A quick check to compare the number of retroreflectivity points (from the retroreflectivity data file) match the number of points obtained and plotted by ArcView. The number of points should match. An alternative check would be to look at the points versus the line segments to determine why these points are not being read. Questions to ask are:

- Is the snap tolerance too small or too large?
- Are the data points on concurrent named routes?
- Document other checks when looking at the data.

6.3.3 Retroreflectivity Data File Preparation

This procedure prepares the retroreflectivity data file to be pulled into ArcGIS. Several items will be done at this point to simplify steps later.

- Open the retroreflectivity data file in Excel.
- Remove the degree symbols from the Latitude and Longitude columns using search and replace (potential for automation).
- Format both these columns as a number and use six or more decimal places.
- Insert a column called RTE_NM (Route Name) this corresponds to the field in the DFO layer.

- Name the route on each row in the RTE_NM column just created. Ensure route name is consistent with the GIS DFO layer (route name is a two letter designation and four numbers, i.e., FM0529).
- You may also want to add a column called SNAP. This is the distance used by the Route Event Layer Tool to determine the radius from the point which a route will be selected, typically 100 ft. This is a snap tolerance distance. If some points do not show up this distance may need to be set to 200 ft.
- It is also helpful to add a column called OFFSET which is the distance from the centerline the data will be plotted. These values may be negative for westbound and southbound, positive for eastbound and northbound.
- Format the time to a 24-hour clock time.
- Name Range: Highlight the data area (exclude header) then name the section something descriptive such as (route name_travel direction_type of marking_marking color (FM0529_EB_SK_WT) (this process works for Excel 2007).

For Excel 2003:

- Delete the header data.
- Enter a logical file name for the exported data such as FM0529_EB_SK_WT.dbf.
- Save as a DBF IV (FM0529_EB_SK_WT) file and close.

6.3.4 Adding Retroreflectivity Points to GIS

The first step will be to open ArcGIS and set the frame properties, primarily setting the coordinate system to state plane NAD 83. The retroreflectivity data points will need to be added and saved as a layer so they will be plotted on the map. The points are then associated or linked to a line segment or route. The procedures are outlined below illustrated with figures.

- Open ArcGIS.
- Set Frame properties (define the coordinate system).
 - Right click the layers on the far left frame and scroll down to properties.
 - In the data frame properties window, select the Coordinate System tab as shown in [Figure 28](#).
 - Select Geographic Coordinate System\North America\North American Datum 1983. This will set the coordinate system for the map.

- Add Retroreflectivity Points to the GIS map (file that was made in previous section).
 - Select the Tools\Add XY data and the dialog box shown in [Figure 29](#) will show up.
 - Use the Browse button to select the file created in Excel.
 - The X and Y field should be filled in with Longitude and Latitude; if not select them.
 - Set coordinate system by pressing the Edit button at the bottom and filling in the appropriate fields (see [Figure 29](#)). It is typically easiest to Import the coordinate system by clicking Import and then select a file with a known coordinate system such as the District DFO file, or you can use the same procedures used to define the coordinate system for the layers.
 - Click Apply then OK you will need to click OK on the original box as well. The points should then be added to your map.
 - You will then need to save these points as a layer. Simply click on the layer then right click and Data / Export. [Figures 30](#) and [31](#) shows the dialog box and naming convention used. A detailed name with the route name, direction of travel, marking type, marking color, and that these are events or points. The events label is important because several files with the same type of name will be created and will be distinguished by points, events, and line.
 - The layer will automatically be added to the map.
- Add District DFO Layer (get the TxDOT name and location).
- Click the plus sign or add feature, locate the file, and add the layer (Ensure that the layer is in NAD 83).
- In the left window click on layers\ right click Properties\Coordinate System\Predefined\ Geographic Coordinate System\North America\North American Datum 1983. Click Apply and OK.

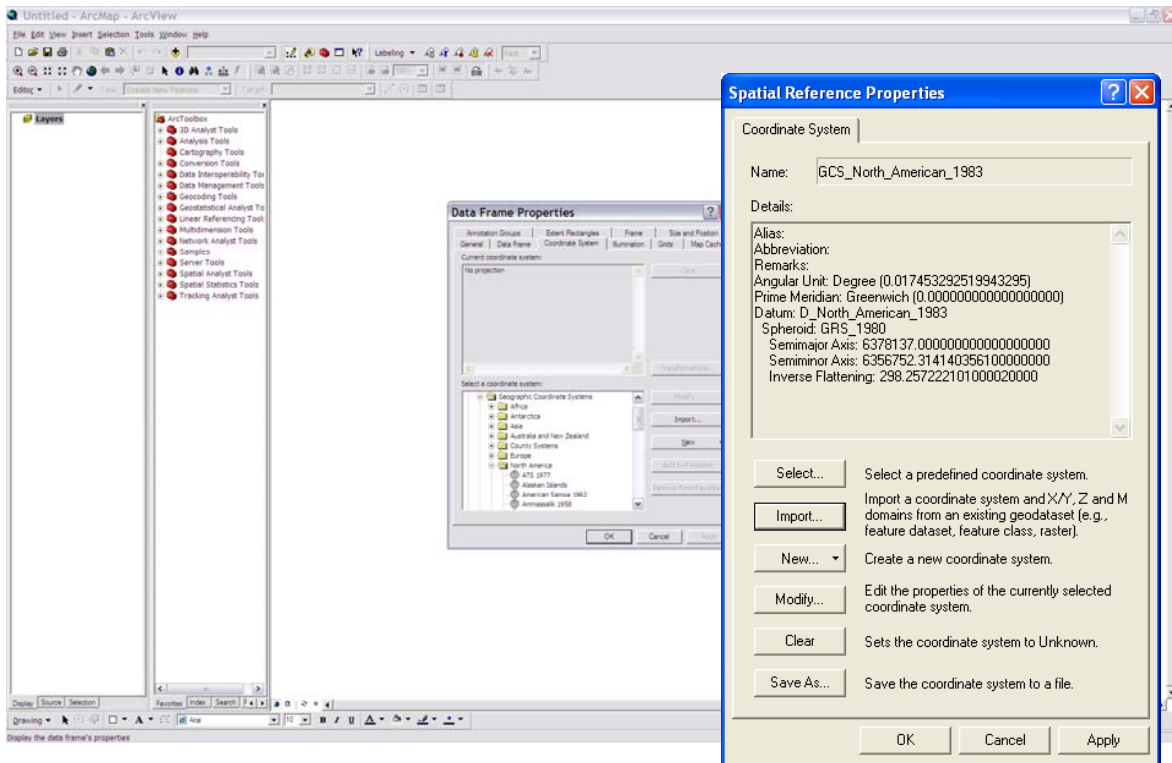

Figure 28. Coordinate System Import Screen.

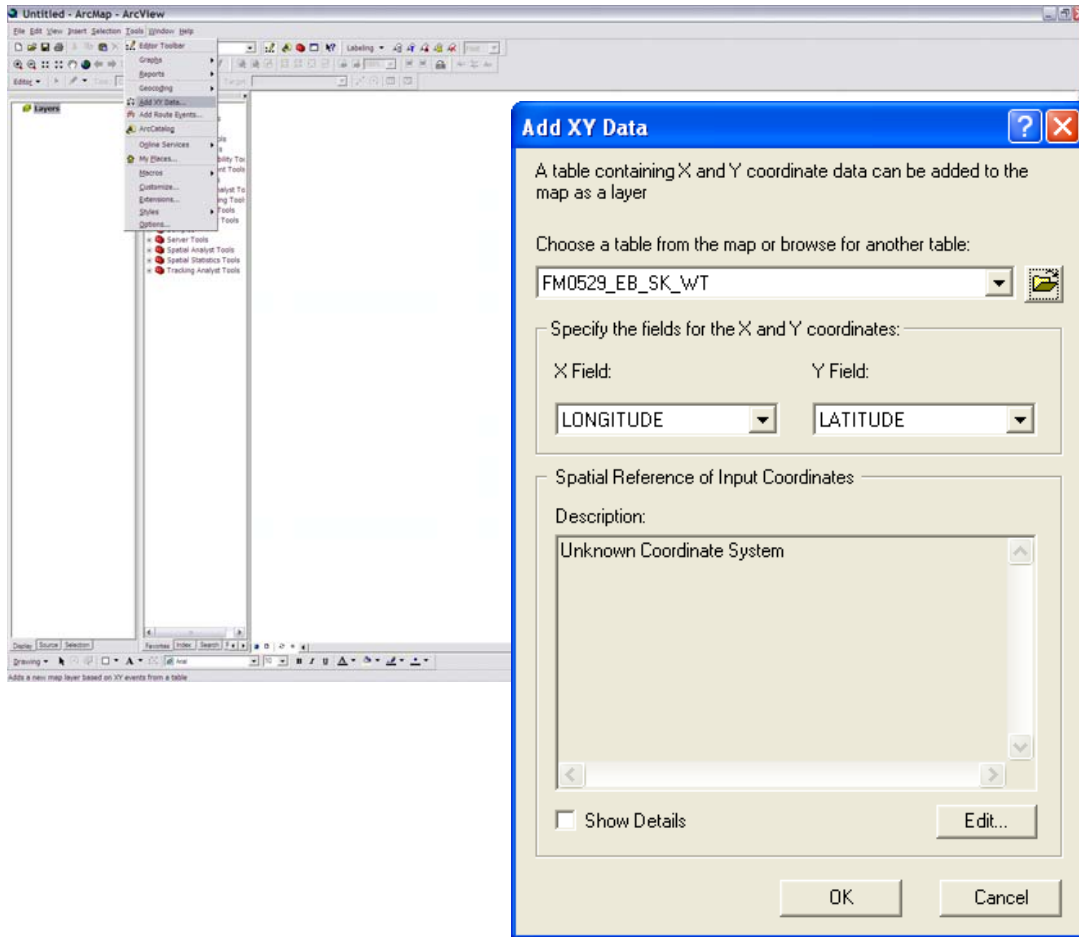

Figure 29. ArcView XY Data Screen.

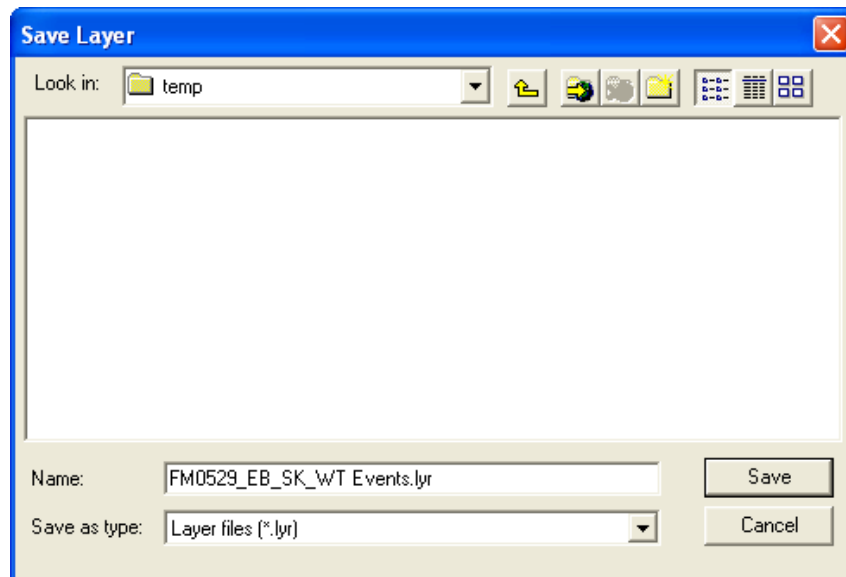

Figure 30. Saving Layer Dialog Box.

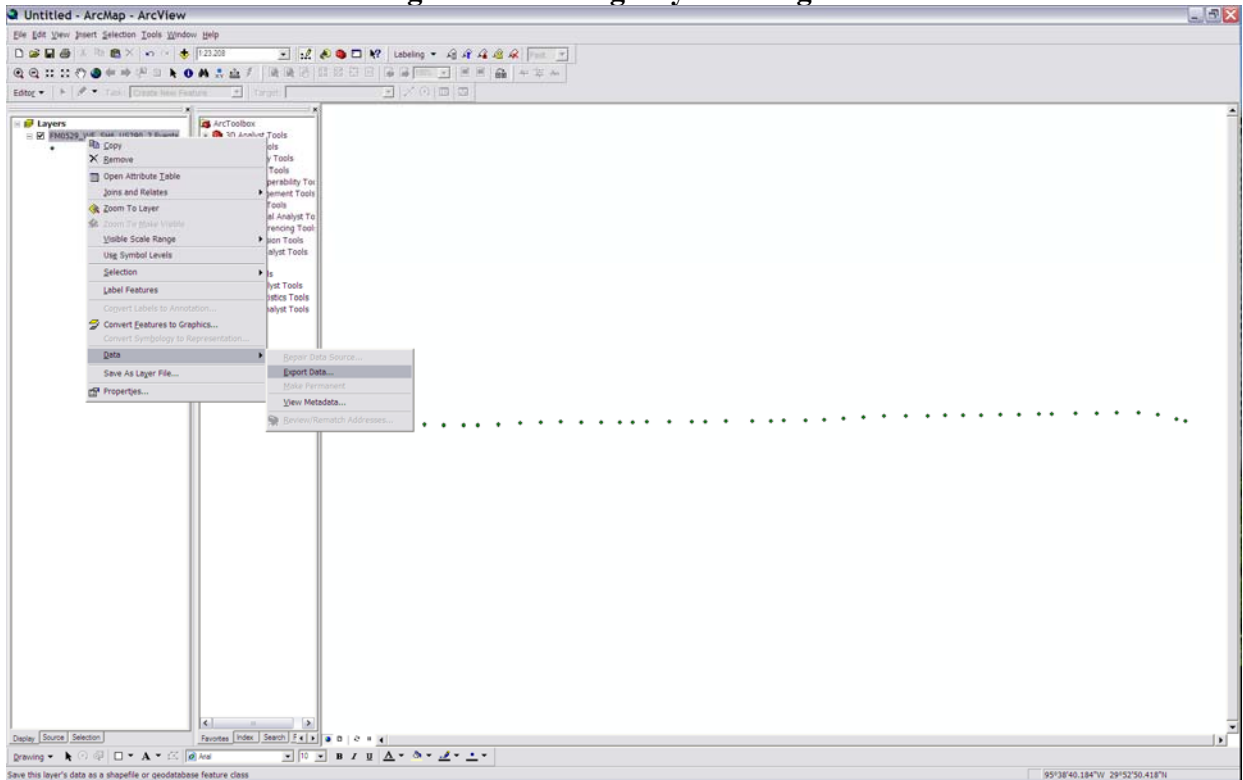

Figure 31. Export of the Point File as a Layer.

6.3.5 Locate Features Along a Route

Next you will want to associate the two files (the point layer and the District DFO layer). This process creates an Event Table that shows the distances along routes where the point data are located.

- Click ArcTool box (little red toolbox)\Linier Referencing Tools\Locate Features Along Routes as shown in [Figure 32](#). This will create an output file that can be DBF XLS or other.

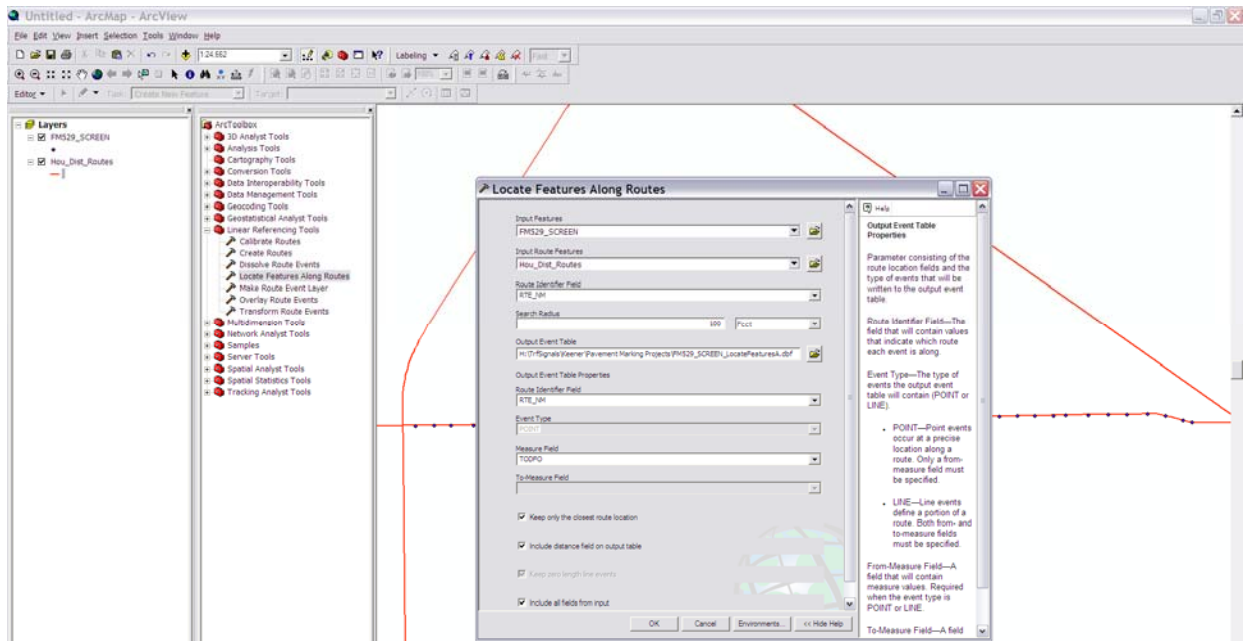

Figure 32. Locate Features Along Routes Tool.

Once you have the dbf or xls file you will need to create a TO and FROM set of latitude longitudes. This creates a TO FROM link. This is done by opening this dbf file (in Excel or Access) and inserting a column called FromDFO. Then copy the data from the TODFO, move to the FromDFO and down one cell and paste the numbers. Save the file which will then be pulled back into ArcView. To obtain the first number in the column, subtract the change rate 1/10 mile and paste it in the DFO column. The steps are outlined below.

- Open the file just created.
- Inset a column and name it From DFO.
- Copy the ToDFO to the new column and down one row.
- Calculate the distance for the first segment (use the 1/10 mile).
- Save the file as a dbf.

Back in ArcView, the dbf file just created will be pulled in using the ArcToolbox\ Linear Referencing Tools\ Make Route Event Layer. The Routes feature is the District DFO layer and use the Route Identifier Field RTE_NM. The dbf file you just created is inserted in the Input Event Table location as shown in [Figure 33](#). Be sure to select the offset field which will allow ArcView to use the field to offset the lines from the centerline.

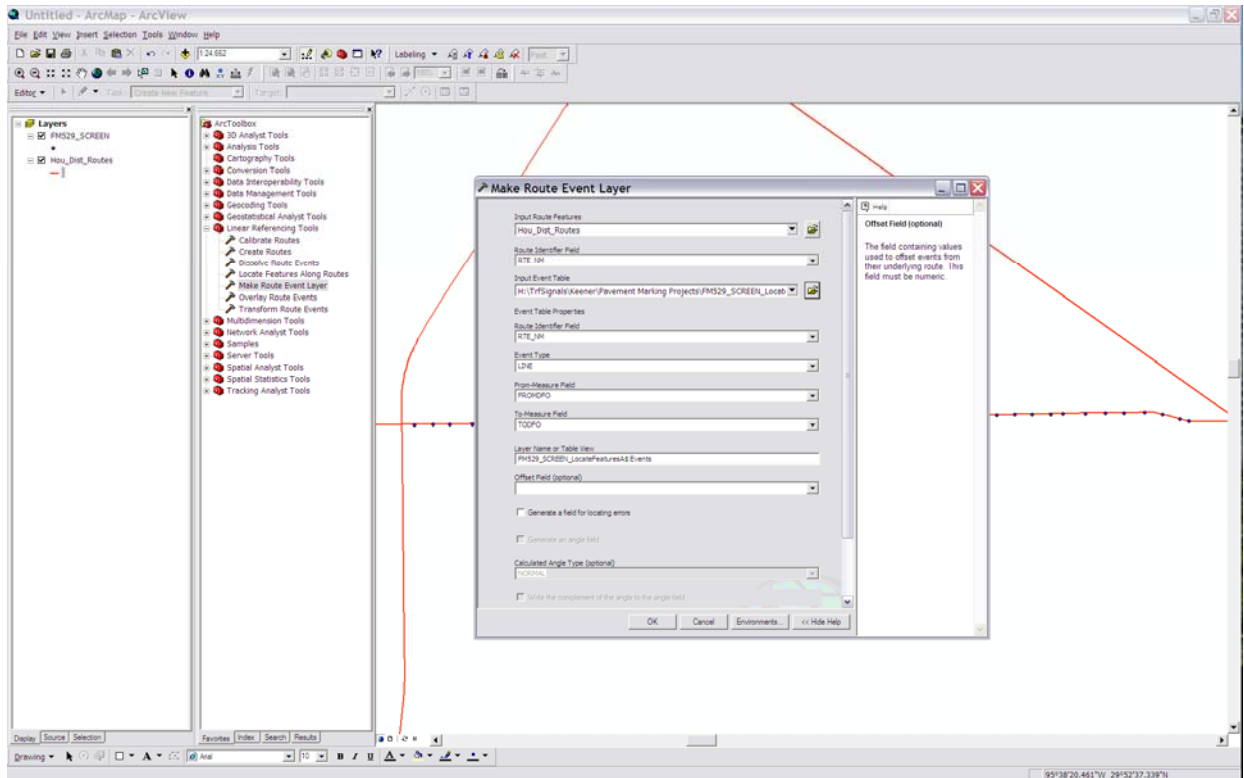

Figure 33. Importing Retro Route File.

It is useful to display this new linier feature using colors. This can be done by right clicking the layer, then select Properties\Symbology\Import Symbology.

You can import the symbology from a previous legend or you can create one using the quantities/graduated colors and define the values you desire. It is suggested that you use below 100 for red 101 to 150 as yellow and above 150 as green.

Note: Older versions of ArcView will only use dbf; however, newer versions can pull in Excel Files.

CHAPTER 7. SUMMARY OF FINDINGS AND RECOMMENDATIONS

7.0 FINDINGS

A good pavement marking has to have good nighttime visibility and presence. The ability of a marking to stay on the roadway and maintain retroreflectivity are what determines the durability of a marking. Some of the factors identified from the literature that contribute toward visibility of pavement markings are color, width, retroreflectivity, presence, contrast, marking type, etc. The influence of the width of pavement markings on visibility has been inconclusive from past literature. One previous study concluded that only up to a critical width, which is undetermined so far, could benefit visibility, and beyond the critical width, wider pavement markings have no influence on visibility (21). Some of the factors identified that impact the presence of a marking are marking material, thickness, marking placement, traffic and environmental conditions, etc.

Retroreflectivity is one of the most important factors for nighttime visibility of pavement markings. There have been several research results reported to identify the minimum acceptable retroreflectivity values for pavement markings. In addition there has been analytical research, where computer models have been developed to estimate minimum retroreflectivity values, as well as many field tests to arrive at minimum retroreflectivity values. The range for minimum retroreflectivity seems to fall between 80 to 130 mcd/m²/lux. Various factors have been found to influence the minimum retroreflectivity values required by a driver, most influencing among those were driver age, marking color, weather condition, marking configuration, and the presence of RRPMS.

A qualitative comparison of handheld and mobile retroreflectometers was done using the information obtained from literature. Handheld retroreflectometers are relatively easy to calibrate and use. ASTM standards have been made available to ensure proper use of handheld retroreflectometers to get accurate readings. Mobile retroreflectometers, being a relatively new option for retroreflectivity assessment, have little guidance on proper calibration and use. However, mobile retroreflectometers, once properly calibrated, can collect data much faster (traveling up to highway speeds) and at more frequent intervals on a given segment of pavement markings when compared to handheld retroreflectometers. Mobile retroreflectometers do not require the user to make stops or lane closures to measure retroreflectivity of pavement

markings, which means less exposure to traffic for the data collection crew. Reducing the exposure makes mobile retroreflectometers a safer means of data collection than handheld.

Quantitative comparisons of handheld and mobile retroreflectometers in the literature have shown that readings taken from both instruments can be within ± 20 percent of each other. However, without proper calibration and operation the values may differ by much more than 20 percent. In the current study measurements were made with handheld and mobile retroreflectometers at several locations utilizing the best practices developed through this research. Markings of both colors and various retroreflectivity levels were measured to cover a wide range of typical markings. Correlation graphs generated with these data showed that mobile readings very closely correlated with handheld readings, with an R^2 of 0.9766. The resulting regression line of the data means that there was only about 2 percent variation between the handheld and mobile readings. When comparing mobile retroreflectivity readings with handheld readings, there are several factors that might influence their correlation. Some of the factors are improper initial calibration of either retroreflectometer, improper data collection procedures, not accounting for measurement variables that may influence the data, and comparing measurements that are not taken in the same location or at a high enough frequency to account for the inherent variability of pavement marking retroreflectivity.

Data collected from the subjective night test evaluations were analyzed in various ways to find any significant trends and correlations especially regarding the actual measured retroreflectivity values. Some significant findings from the analysis are:

- average subjective ratings do show acceptable correlation with actual retroreflectivity measurements;
- average subjective ratings show that the contrast between the marking and the pavement can influence retroreflectivity ratings;
- individual ratings can show large variations from individual to individual;
- some probable factors that influence individual rating could be:
 - experience – evaluator’s familiarity in assessing retroreflectivity;
 - visual acuity of raters;
 - ambient light, etc.; and
- minimal training given to evaluators did not show much improvement in retroreflectivity assessment. It is possible that more in-depth training could be

beneficial in getting slightly more reliable pavement marking retroreflectivity assessment.

The evaluation of the variables that affect the accuracy of mobile retroreflectivity data collection yielded many useful findings. Tests in both static and dynamic conditions were used to isolate variables and determine their effect on the accuracy of the retroreflectometer. Researchers tested user adjustable values, equipment setup, data collection techniques, and compensation for variables.

Researchers found that the effects of data collection speed, data collection acquire frequency, and nighttime data collection had little practical impact on the retroreflectivity readings. Data collection speed did impact the number of readings over a given length of marking, because fewer readings can be taken when traveling at higher speeds. Data collection acquire frequency only impacted how detailed the data would be over a given length, because the longer the distance the data are averaged over, the less detailed the data will be. Nighttime data collection had little impact on the retroreflectivity readings. Researchers found that to collect the best data, calibration should take place at night with the vehicles low beams on.

The signal to noise ratio (SNR), RRPM level, and collecting data on double lines all influenced the data collected. The SNR needs to be set to an appropriate level to factor out the background noise yet allow the software to capture all of the retroreflectivity readings. The SNR value needs to be adjusted as pavement marking retroreflectivity levels, pavement surface, and data collection conditions change. The RRPM level needs to be set at a high enough level so that the pavement marking retroreflectivity levels are not filtered out, but low enough to filter out all of the retroreflectivity values from the RRPMs. Researchers found that data collection on double lines did not always result in an equal number of readings for the right and left line. Due to vehicle wander, and the method in which the software assigns the data it is not unrealistic to have the number of right points be 3/4 the number of left points when measuring a double solid line.

The two major variables influencing the mobile retroreflectivity data collection are the operating temperature changes of the retroreflectometer and the measurement position across the measurement window. Researcher found that both of these variables had a significant impact on the results of the retroreflectivity data collection. Researchers also determined that the impact of both of these variables will be unique to each individual mobile retroreflectometer and the vehicle that it is setup on. The good news is that both of these variables have compensation

algorithms built into the software to account for them. Testing of the mobile retroreflectometer to determine the impact of the variable and implementation of the correction factors greatly reduces the impact of the variable.

Procedures for a data collection plan were developed and utilize performance curves based on marking age, ADT per lane, and marking type. Knowing the roads that have been or will be resurfaced or seal coated in the past year or upcoming year will rule out many roadways that need to be measured. Roadways that receive a low subjective test rating or customer complaint are roadways that need to have a retro readings measured. These initial criteria should limit a lot of the data collection; however, data will still need to be collected on a reduced sample of roadways the size of which will be dependent on budget. The same procedure can be used for the subset of warranty pavement markings also.

The ability to attach retroreflectivity files to the TxDOT DFO maps and thus to the TxDOT referencing systems is a great benefit. Making these linkages allows the user to tap other TxDOT databases, which in time can help lead to a Pavement Marking Management system (PMMS). A PMMS will allow TxDOT staff to more efficiently sample the retro data, develop performance curves, predict, and plan efficient marking replacement.

In addition to linking to different databases, linking the data to the DFO maps allows staff to develop useful, user-friendly maps to aid in decision making. The GIS procedures laid out in the document are detailed to allow staff with some GIS experience to make the linkages and maps. These procedures have the first level of prototype automation. These procedures, when used over time, will become more efficient and user-friendly. The ability to create the maps and automate some of the procedures fulfills the need of district staff. The request to reduce the amount of data really equates to a request for better tools to analyze and display the retroreflectivity data. Mapping the retro data allows a quick glimpse of a district or region to determine where problem areas are located.

7.1 RECOMMENDATIONS

This study showed subjective retroreflectivity ratings can be biased by the individual evaluating the pavement markings, and subjective evaluation does not always follow the trends obtained with quantitative measurements. It is recommended that subjective rating methods only be used when handheld or mobile retroreflectometers are not available. Subjective evaluators

need to be well trained or multiple evaluators can be utilized, averaging the reported ratings. However when possible, subjective evaluation should be complemented with quantitative measurements with mobile or handheld retroreflectometers to ensure proper evaluation and efficient allocation of funds for prioritizing pavement marking restriping projects.

Handheld retroreflectometers provide a simple and easy means of getting quantitative retroreflectivity data. ASTM standards should be used when collecting handheld retroreflectivity data. The disadvantage of handheld retroreflectivity readings is the speed of data collection and the potential risk to the data collectors by being exposed to traffic. Using handheld retroreflectometers to verify and/or quantify visual inspection or user complaints is very beneficial.

The best practices for mobile retroreflectivity are fully documented in deliverable 0-5656-P1 (50). The best practices include the following with regards to the operation of the mobile retroreflectometer:

- proper setup of the equipment and software,
- sensitivity testing for compensation of variables,
- proper calibration techniques with methods to check the accuracy of the system, and
- methods to reduce the impact of variables that could negatively impact the retroreflectivity data results.

Cost prohibits measuring all markings on all roadways on a cyclical basis. A means of sampling sections of roadways to reduce the number of segments that need to be collected will save time, money, and effort. Several steps can be followed to reduce the number of segments required to be sampled:

- take out roadway segments that have been restriped, resurfaced, seal coated, or some other surface treatment in the past year;
- take out roadway segments that will be restriped, resurfaced, seal coated, or some other surface treatment in the coming year;
- road segments that fall below the unacceptable line or close to the line of the regression model of time and ADT should be measured;
- regression curves will need to be developed based on location:
 - weaving sections;

- horizontal curves;
- tangent sections;
- regression curves will need to be developed for material types:
 - thermoplastic;
 - tape;
 - paint;
 - multi-polymers;
- regression curves will need to be developed for for pavement types:
 - concrete;
 - asphalt; and
 - seal coats.

One of the largest areas of need is in the analysis, display, and automation of the data. The data can be overwhelming but with good tools the data can quickly and efficiently be reduced and analyzed. Using GIS to link the retroreflectivity data to PMIS database will allow a robust analysis linking the retroreflectivity data to pavement types, paving installation dates, etc. The answers to many questions should be possible by making those connections. As patterns and types of analysis become common place, further automation of time consuming steps will be useful in reducing the effort required to reduce the retroreflectivity data. Mapping and graphing procedures have been document and automated as part of this project.

Additional investigations into other measurable characteristics have potential using machine vision, lasers, and other emerging technologies. Research conducted in TxDOT project 0-5882-1, which used a scanning laser to determine the thickness of a pavement marker, is one area that holds promise. Combining the thickness measuring software and equipment with the retroreflectivity software enables the same staff to gather data on the marking thickness. This additional data can be used to better evaluate the life expectancy of the markings. Modification to the software to measure the width of each line might also be a useful tool to determine the consistency of markings and ensuring the cost effectiveness of the pavement marking system.

REFERENCES

1. National Highway Traffic Safety Administration (NHTSA). Traffic Safety Facts. U.S. Department of Transportation, Washington, D.C. 2008.
2. TxDOT Special Specification 8094. *Mobile Retroreflectivity Data Collection for Pavement Markings*. 2004 Specifications, Last update May 2008.
<ftp://ftp.dot.state.tx.us/pub/txdot-info/cmd/cserve/specs/2004/spec/ss8094.pdf>.
3. Carlson P.J. and H.G. Hawkins. *Updated Minimum Retroreflectivity Levels for Traffic Signs*, Federal Highway Administration Report FHWA-RD-03-081, July 2003.
4. Bahar G., M. Masliah, T. Erwin, E. Tan, and E. Hauer. Pavement Marking Materials and Markers: Real-World Relationship Between Retroreflectivity and Safety Over Time, NCHRP Web Only Document 92, Transportation Research Board, April 2006.
5. TxDOT. *Pavement Marking Handbook*, Texas Department of Transportation, August 2004.
6. Sarasua W.A., D.B. Clarke, and W.J. Davis. *Evaluation of Interstate Pavement Marking Retroreflectivity*, Clemson University, Report number FHWA-SC-03-01, April 2003.
7. Migletz, J. and J.L. Graham. Long-Term Pavement Marking Practices, NCHRP Synthesis 306, Transportation Research Board, Washington D.C., 2002.
8. MUTCD 2003 Edition. <http://mutcd.fhwa.dot.gov>. Accessed on March 10, 2007.
9. ASTM International. *Standard Test Method for Measurement of Retroreflective Pavement Marking Materials with CEN-Prescribed Geometry Using a Portable Retroreflectometer*. Designation E1710-05. West Conshohocken, PA, 2005.
10. Holzschuher, C. and T. Simmons. *Mobile Retroreflectivity Characteristics for Pavement Markings at Highway Speeds*. Research Report FL/DOT/SMO/05-486. Florida Department of Transportation, May, 2005.
11. Cottrell B.H. and R.A. Hanson. *Determining the Effectiveness of Pavement Marking Materials*, Virginia Transportation Research Council Report number VTRC 01- R9, February 2001.
12. Loetterle F.E., R.A. Beck, and J. Carlson. *Public Perception of Pavement Marking Brightness*, Transportation Research Record 1715, Transportation Research Board, Washington D.C., 2000, pp. 51-59.
13. McGinnis R.G. *Pavement Marking Benchmarking*. Report FHWA-PA-2001-027-97-04, Pennsylvania Transportation Institute, Pennsylvania State University, PA, October 2001.

14. Debaillon, C., P.J. Carlson, G. Hawkins, Y. He, T. Schnell, and F. Aktan. *Recommendations for Minimum Pavement Marking Retroreflectivity Values Based on TARVIP Analyses*. Submitted for Presentation at 18th Biennial TRB Visibility Symposium, College Station, TX, April 2007.
15. Molino, J.A., K.S. Opiela, C.K. Andersen, and M.J. Moyer. Relative Luminance of Retroreflective Raised Pavement Markers and Pavement Marking Stripes on Simulated Rural Two-Lane Roads. *Transportation Research Record 1844*. Transportation Research Board, National Research Council, Washington D.C., pp. 45-51, 2003.
16. Molino, J.A., B.J. Katz, D.E. Duke, K.S. Opiela, C.K. Andersen, and M.J. Moyer. Field Validation for the Relative Effectiveness of Combinations of Pavement Markings and Retroreflective Raised Pavement Markers in Recognizing Curves at Night. *TRB 2004 Annual Meeting CD-ROM*. Transportation Research Board, National Research Council, Washington D.C., 2004.
17. P.J. Carlson, J.D. Miles, M.P. Pratt, A.M. Pike. *Evaluation of Wet-Weather Pavement Markings: First Year Report*. Technical Report. 0-5008-1. Texas Transportation Institute, College Station, TX. September 2005.
18. Gibbons, R. B., J. M. Hankey, and I. Pashaj. *Wet Night Visibility of Pavement Markings*. VTRC 05-CR4. Virginia Transportation Research Council, Charlottesville, Oct. 2004.
19. Rumar, K., M. Sivak, E.C. Traube, and T. Miyokawa. *Nighttime Visibility of Retroreflective Pavement markings from Trucks versus Cars*. Report UMTRI-99-34, University of Michigan Transportation Research Institute, Ann Arbor, Michigan, 1999.
20. Lundkvist S. and S. Astrom. The Performance of Wet Visibility Road Markings- final report on Provvag 1998-2000, Report 465A Swedish National Road and Transport Research Institute, 2000.
21. Gibbons R.B., M.J. McElheny, and C. Edwards. The Impact of Pavement Marking Width on Visibility Distance, Presented at 2006 TRB Annual Meeting, Transportation Research Board, January 2006.
22. "Pavement Marking Management System." *Reference Manual*, Minnesota Department of Transportation, St. Paul, MN, May 1998.
http://safety.fhwa.dot.gov/roadway_dept/retro/pavement/pave_tech.htm. Accessed June 2008.
23. Hawkins, N., O. Smadi, and Z. Hans. Iowa Pavement Marking Management System: Initial Phases. Proceedings of the 2005 Mid-Continent Transportation Research Symposium, Ames, Iowa, August 2005.

24. Hawkins, N., O. Smadi, Z. Hans, and T. Maze. Pavement Marking Management: An Integrated Approach. Submitted for consideration at the *2006 TRB Annual Meeting*. Transportation Research Board, National Research Council, Washington D.C., 2005.
25. McDiarmid, M. *NCDOT Pavement Marking Asset Management Program*. Presented at the Traffic Engineering Conference for Operations and Safety. September 2004.
26. Carney, J. MoDOT's Inventory Systems and Measures for Pavement Marking and Roadway Signing. Presented at the Midwest Regional University Transportation Center, Maintenance Quality Assurance Peer Exchange, Madison, Wisconsin, October 2004.
27. B.C. Traffic Engineering, Inc. *Pavement Marking Management System: Phase I*. Missouri Department of Transportation, Report Number RDT 00-008, August 2000.
28. Weinkein, D., R. Branham, and V. Ginder. *District 7 Report on Phase 1 and 2 on the Pavement Marking Management System Research Projects*. Missouri Department of Transportation, Report Number RDT 02-010, November 2002.
29. Carlson P.J. and H.G. Hawkins. *Development of Minimum Traffic Sign Retroreflectivity Levels in The U.S. and Implementation Strategies*. ITE 2005 Annual Meeting and Exhibit Compendium of Technical Papers. Institute of Transportation Engineers, 2005.
30. Federal Docket Management System. *National Standards for Traffic Control Devices; the Manual on Uniform Traffic Control Devices for Streets and Highways; Minimum Retroreflectivity Guidelines for Traffic Signs*. <http://www.regulations.gov/fdmspublic/component/main?main=DocumentDetail&o=090000648037d57b> Docket FHWA-2003-15149. Accessed on August 8, 2008.
31. Ethen, J.L. and H.L. Woltman. Minimum Retroreflectance for Nighttime Visibility of Pavement Markings. In *Transportation Research Record: Journal of the Transportation Research Board, No. 1093*, Transportation Research Board of the National Academies, Washington, D.C., 1986, pp. 43-47.
32. Graham, J.R. and L.E. King. Retroreflectivity Requirements for Pavement Markings. In *Transportation Research Record: Journal of the Transportation Research Board, No. 1316*. Transportation Research Board of the National Academies, Washington, D.C., 1991, pp. 18-23.
33. Zwahlen H.T. and T. Schnell. Pavement Marking Visibility Research and Proposed Values for Minimum Required Pavement Marking Retroreflectivity, Draft Report for Federal Highway Administration, August 1998.
34. Zwahlen H.T. and T. Schnell. *Minimum In-Service Retroreflectivity of Pavement Markings*. In *Transportation Research Record 1715*, TRB, Washington D.C., 2000, pp. 60-70

35. Parker, N.A. *Evaluation of the Performance of Permanent Pavement Markings and Retroreflectors in Snowplowable Raised Pavement Markers*. Report 55657-01-13. New Jersey Department of Transportation, Trenton, New Jersey, 2002.
36. Oh, U.H. and H.S. Lee. Minimum Retroreflectivity for Pavement Markings from Static and Dynamic Tests. TRB Annual Meeting CD ROM, 2006.
37. Graham, J.R., J.K. Harrold, and L.E. King. Pavement Marking Retroreflectivity Requirements for Older Drivers. In *Transportation Research Record: Journal of the Transportation Research Board, No. 1529*. Transportation Research Board of the National Academies, Washington, D.C., 1996, pp. 65-70.
38. Debaillon C., P.J. Carlson, Y. He, T. Schnell, and F. Aktan. Updates to Research on Recommended Minimum Levels for Pavement Marking Retroreflectivity to Meet Driver Night Visibility Needs. Federal Highway Authority Report, FHWA-HRT-07-059, October 2007.
39. *Evaluation Findings of the Laserlux Mobile Pavement Marking Retroreflectometer*. Highway Innovative Technology Evaluation Center Report # 40466, January 2000.
40. *Evaluation Findings of the Ecodyn Mobile Pavement Marking Retroreflectometer*. Highway Innovative Technology Evaluation Center report # 40470, January 2000.
41. Holzschuher, C. Presentation on “Mobile Retroreflectivity Testing for a PMMS.” <http://www.dot.state.fl.us/structures/DesignConf2006/Presentations/session52/Final-52Holzschuher.pdf> Accessed on 12/1/2006.
42. *Summary of Evaluation Findings for 30-meter Handheld and Mobile Pavement Marking Retroreflectometers*. Highway Innovative Technology Evaluation Center Report # 40525, March 2001.
43. Lindley, J.K., K. Yellapu, and S. Thitipat. *Evaluation of Retroreflectometers*. UTCA Report 02402. University Transportation Center for Alabama, The University of Alabama, August, 2002.
44. Hawkins, H.G., M.A. Sneed, and C.L. Williams. *Evaluation of Traffic Control Devices: Third-Year Activities*. Research Report. 0-4701-3. Texas Transportation Institute, College Station, TX. January 2007.
45. Kopf, J. *Reflectivity of Pavement Markings: Analysis of Retroreflectivity Degradation Curves*. Research Report WA-RD 592.1. Washington State Transportation Center Report, Seattle, WA. September 2004.

46. Fletcher, J., J. Gonos, B. Choubane, and C. Holzschuher. *Calibration Standards for Mobile Retroreflector Units (MRU)*. Paper Number 08-2779. Presented at the 87th Annual Meeting of the Transportation Research Board, Washington D.C., 2008.
47. Maerz, N.H., B. Swindall, and C. Davies. LASERLUX: Automated Real Time Pavement Marking Retroreflectivity Measurements. <http://web.mst.edu/~norbert/pdf/00075.PDF>
48. Pardillo, J.M. and P.J. Hatzi. *Laserlux Mobile Retroreflector Operational Testing Results*. Report FHWA-SA-97-016. Federal Highway Administration, Washington, D.C., 1996
49. Fletcher, J., A. Philpott, B. Choubane, and C. Holzschuher. *Characterization and Mitigation of Temperature Sensitivity within Mobile Retroreflectivity Unit*. In Transportation Research Record 2015. Transportation Research Board, National Research Council, Washington, D.C., 2007.
50. Benz, R.J., A.M. Pike, S.P. Kuchangi, and Q. Bracket. *Mobile Retroreflectivity Best Practices Handbook*. Research Report 0-5656-P1. Texas Transportation Institute, College Station, TX. October 2008.

APPENDIX A:
NIGHT RETROREFLECTIVITY RATING FORM

Table A-1. 5656 Project Demo and Night-Time Pavement Marking Evaluation (Thursday 6-28-07).

Participant Name _____ Age _____ Position in vehicle _____

Segment	Line Location	Poor		Excellent		Overall Quality & Appearance	Traffic	Lighting	Comments
		1	2	3	4				
47 N (1)	Edge						Y / N	Y / N	
21W (2)	Edge						Y / N	Y / N	
21 W Bridge (3)	Edge						Y / N	Y / N	
50 S (4)	Edge						Y / N	Y / N	
50 S (5)	Center						Y / N	Y / N	
50 S (6)	Edge						Y / N	Y / N	
60 E (7)	Edge						Y / N	Y / N	
Victoria (8)	Center						Y / N	Y / N	
Graham (9)	Edge						Y / N	Y / N	
Victoria (10)	Edge						Y / N	Y / N	
40 SE (11)	Edge						Y / N	Y / N	
40 SE (12)	Center						Y / N	Y / N	
40 SE (13)	Center (sect 2)						Y / N	Y / N	
WD Fitch(14)	Skip						Y / N	Y / N	
WD Fitch(15)	Edge						Y / N	Y / N	
6 West (16)	Edge						Y / N	Y / N	

APPENDIX B:
DETAILED ANALYSIS OUTPUT

Figure B-1. Comparison of Mobile Measurements with Human Judgment by Color Ratings.

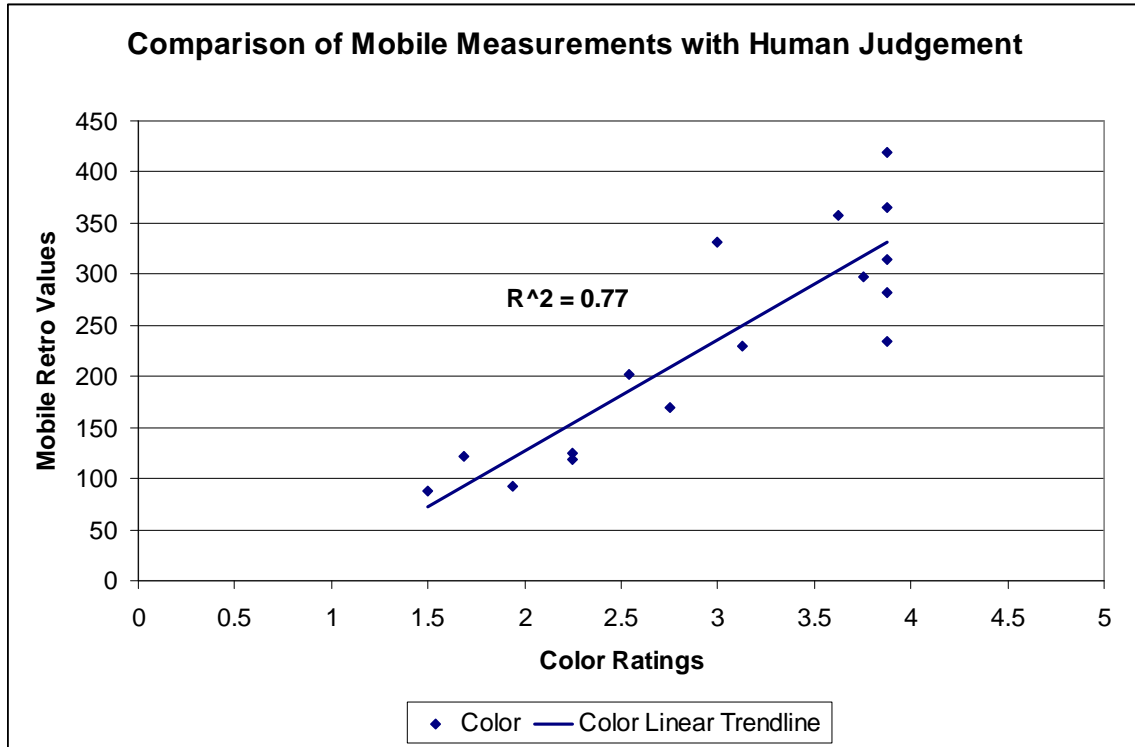

Figure B-2. Comparison of Mobile Measurements with Human Judgment by Contrast Ratings.

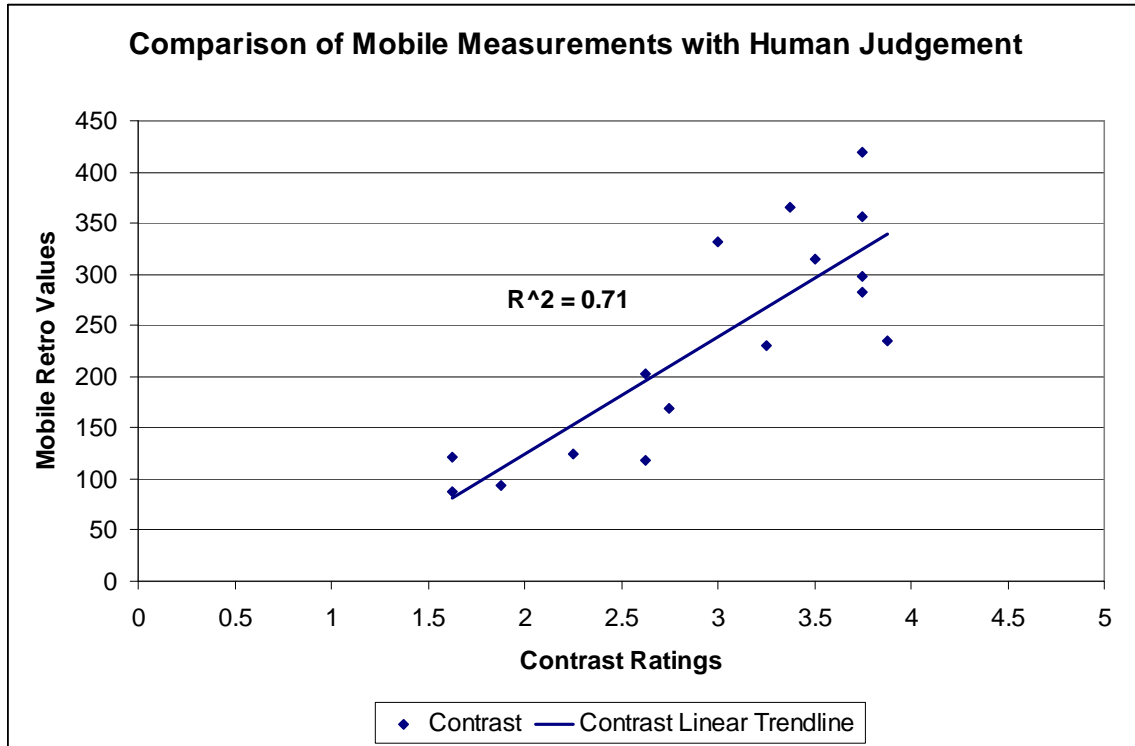

Figure B-3. Comparison of Mobile Measurements with Human Judgment by Overall Quality Ratings.

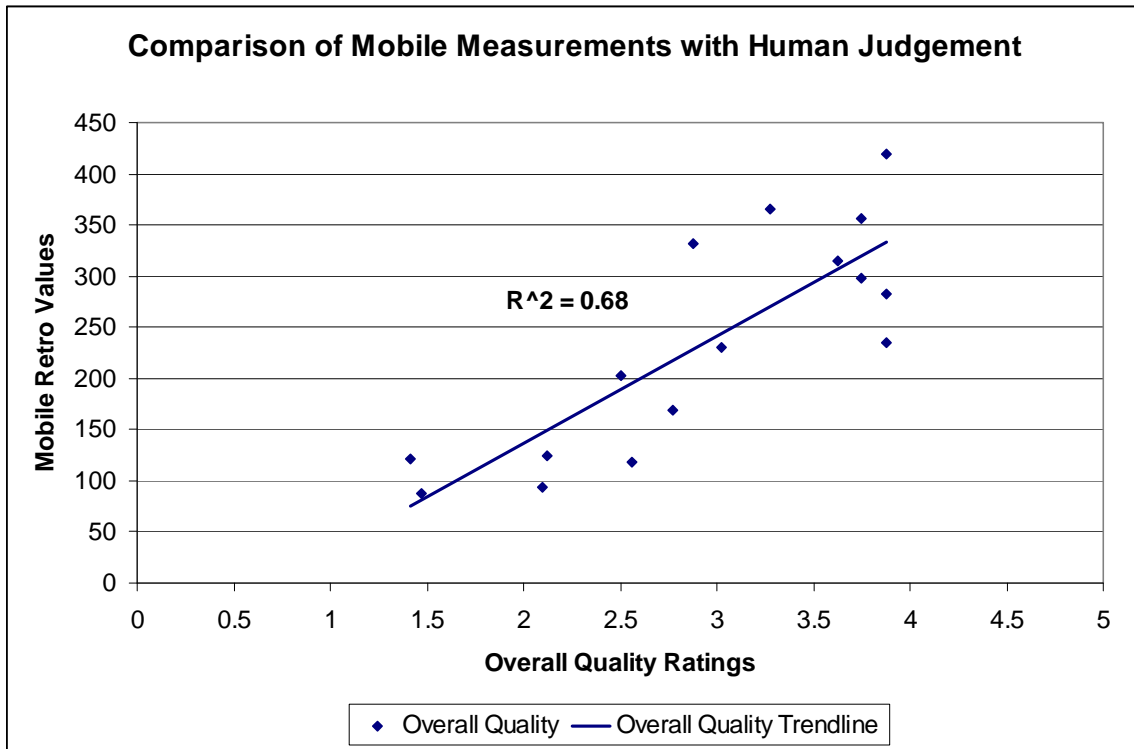

Figure B-4. Pavement Marking Rating Trend Analysis by Average Color Ratings.

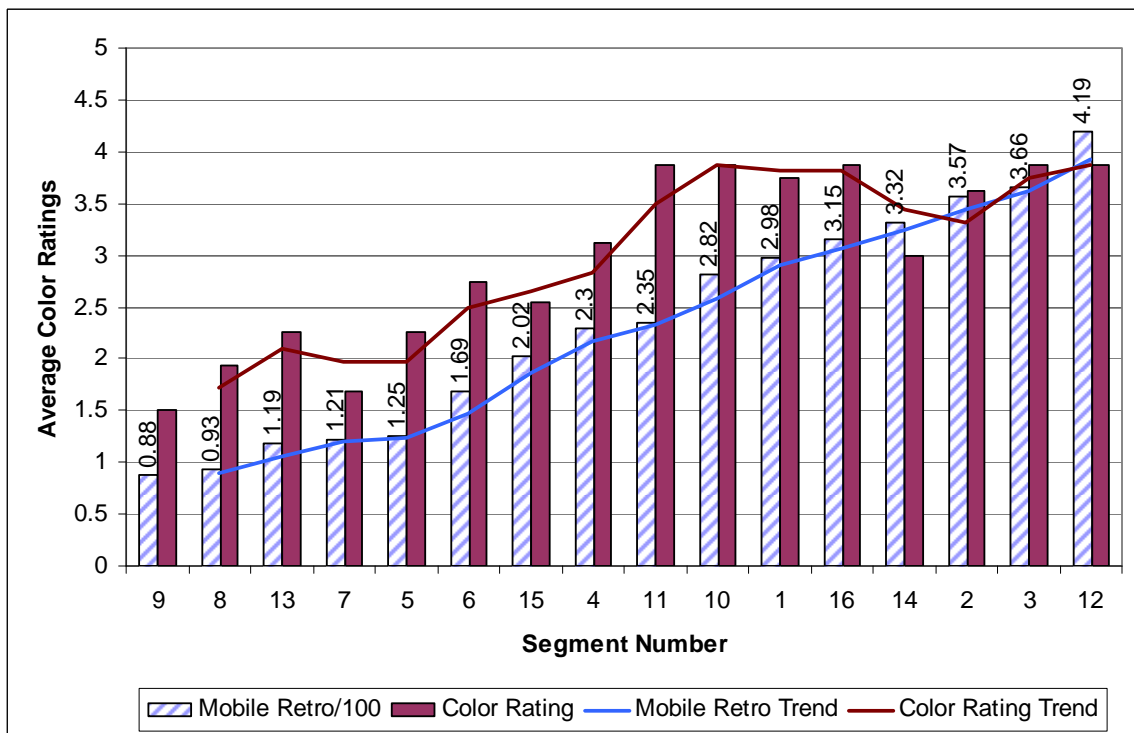

Figure B-5. Pavement Marking Rating Trend Analysis by Contrast Ratings.

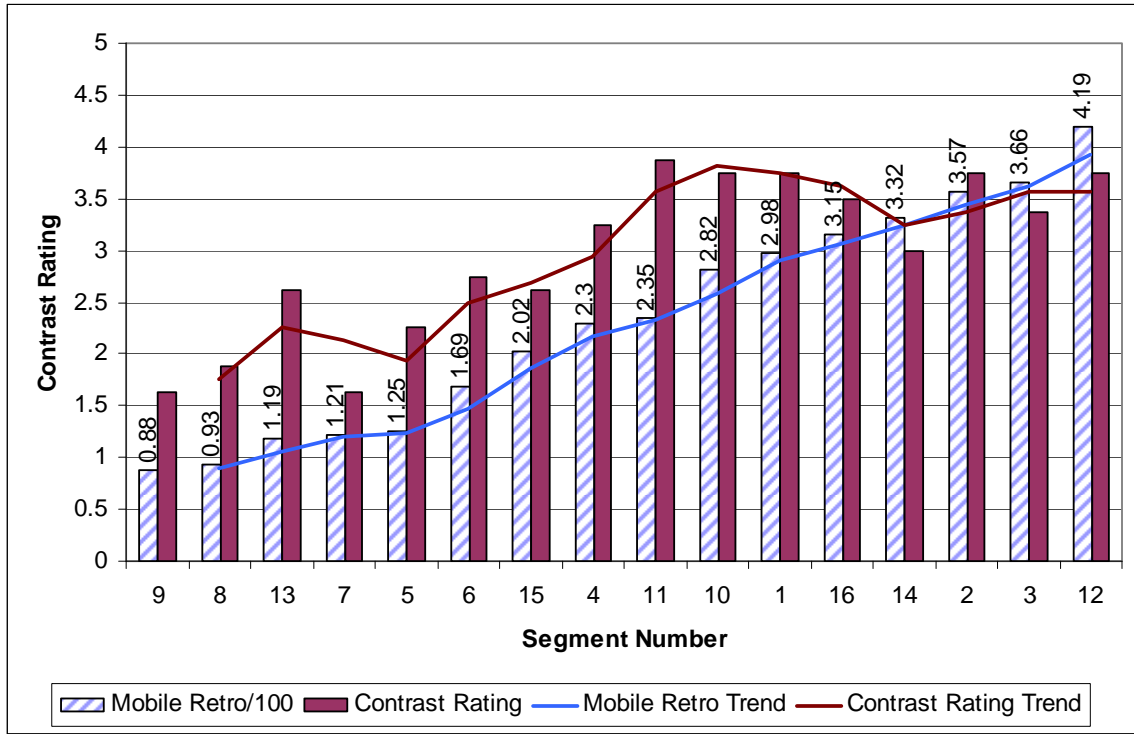
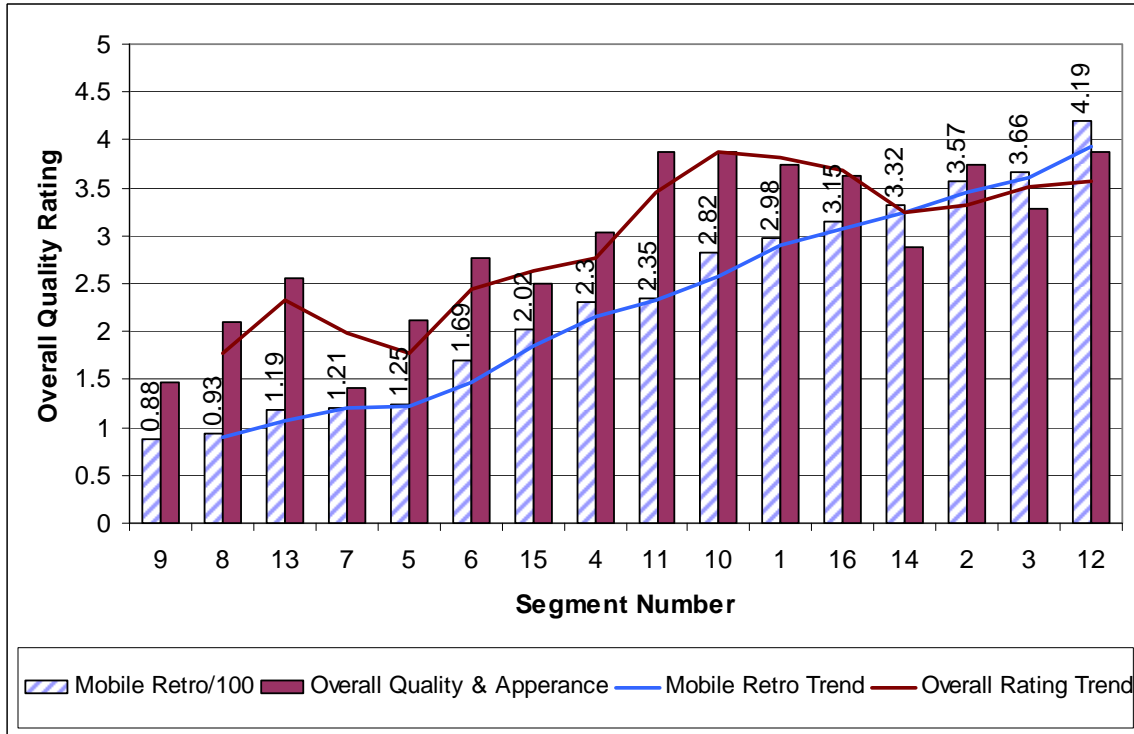

Figure B-6. Pavement Marking Rating Trend Analysis by Overall Quality Ratings.



APPENDIX C:
INDIVIDUAL RETRO-RATING GRAPHS

Figure C-1. Individual Retro-Ratings for Subject 1.

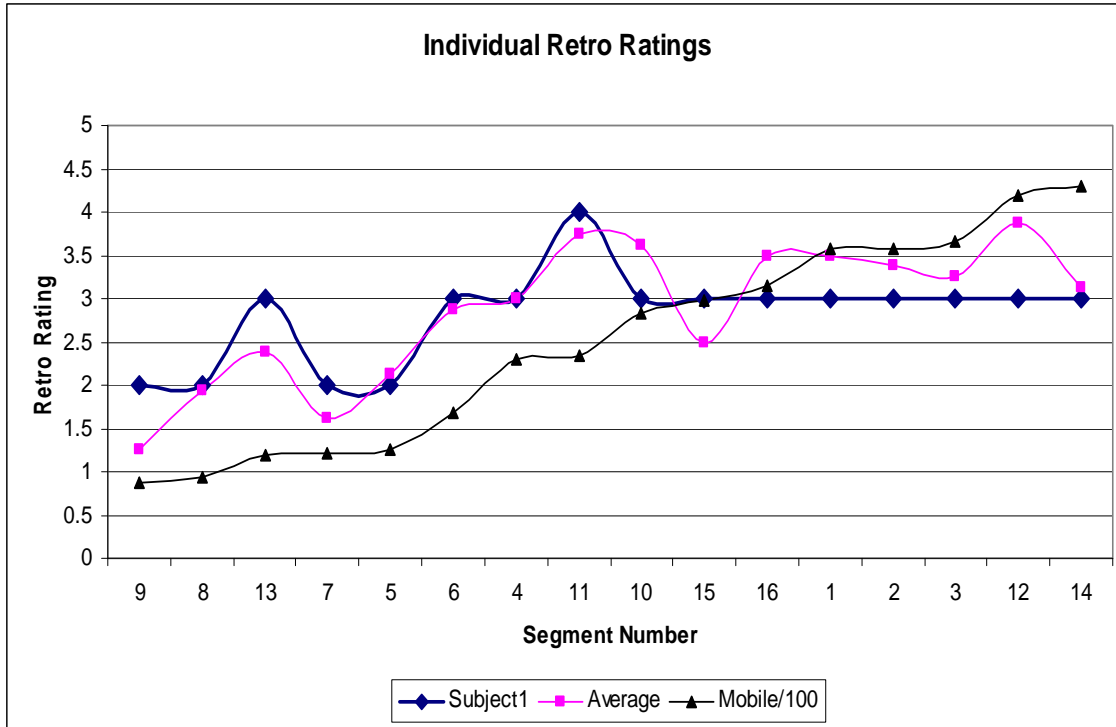

Figure C-2. Individual Retro-Ratings for Subject 2.

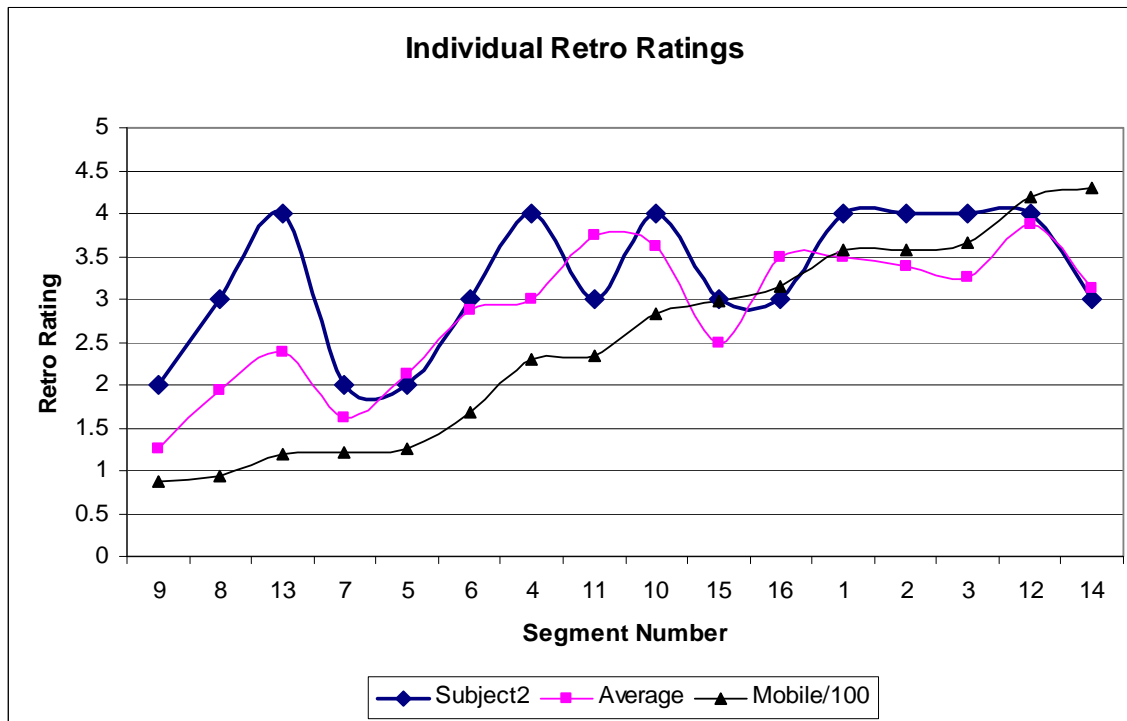

Figure C-3. Individual Retro-Ratings for Subject 3.

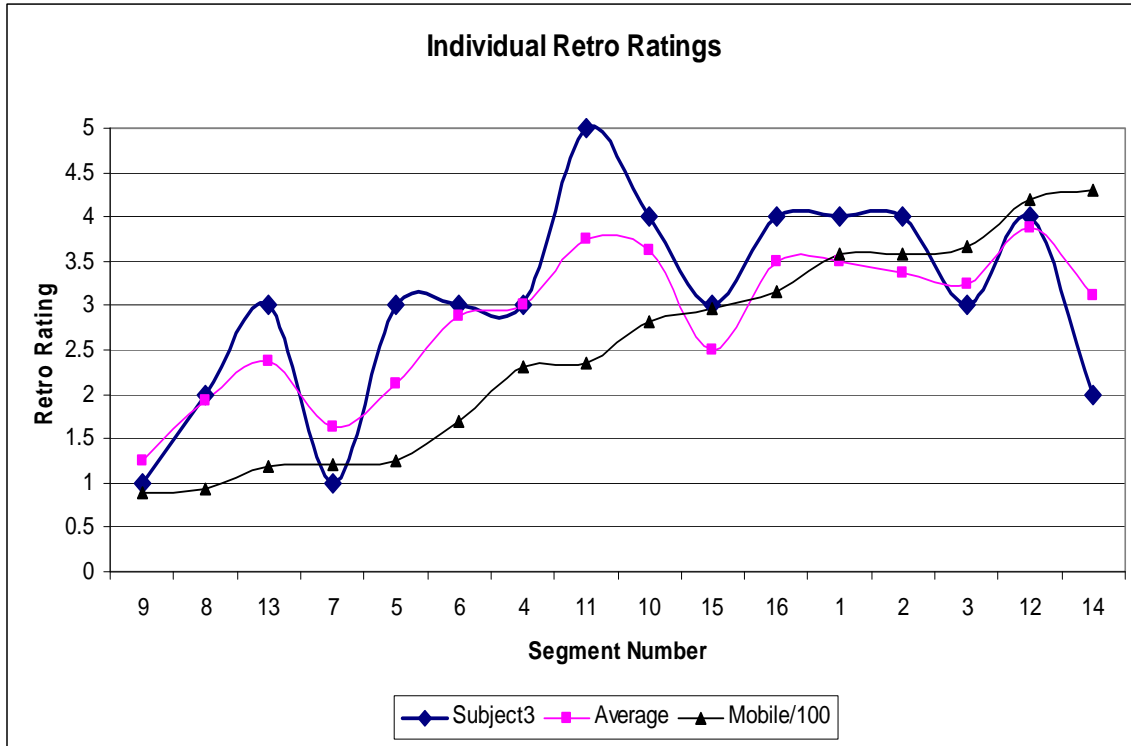

Figure C-4. Individual Retro-Ratings for Subject 4.

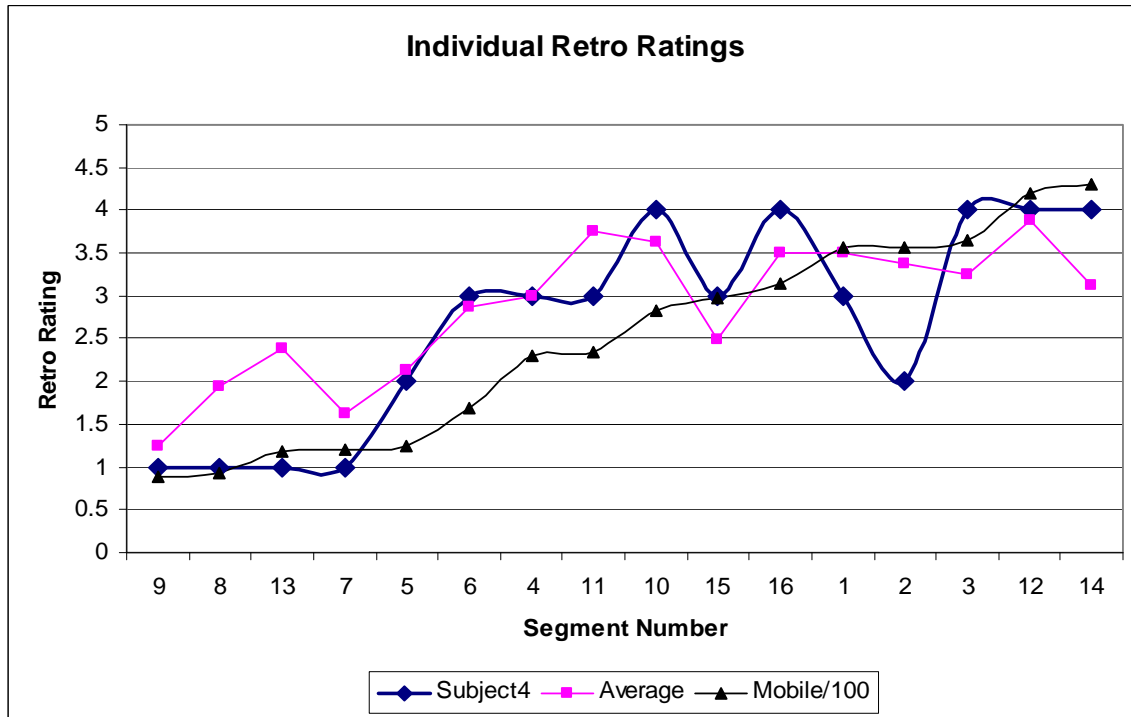

Figure C-5. Individual Retro-Ratings for Subject 5.

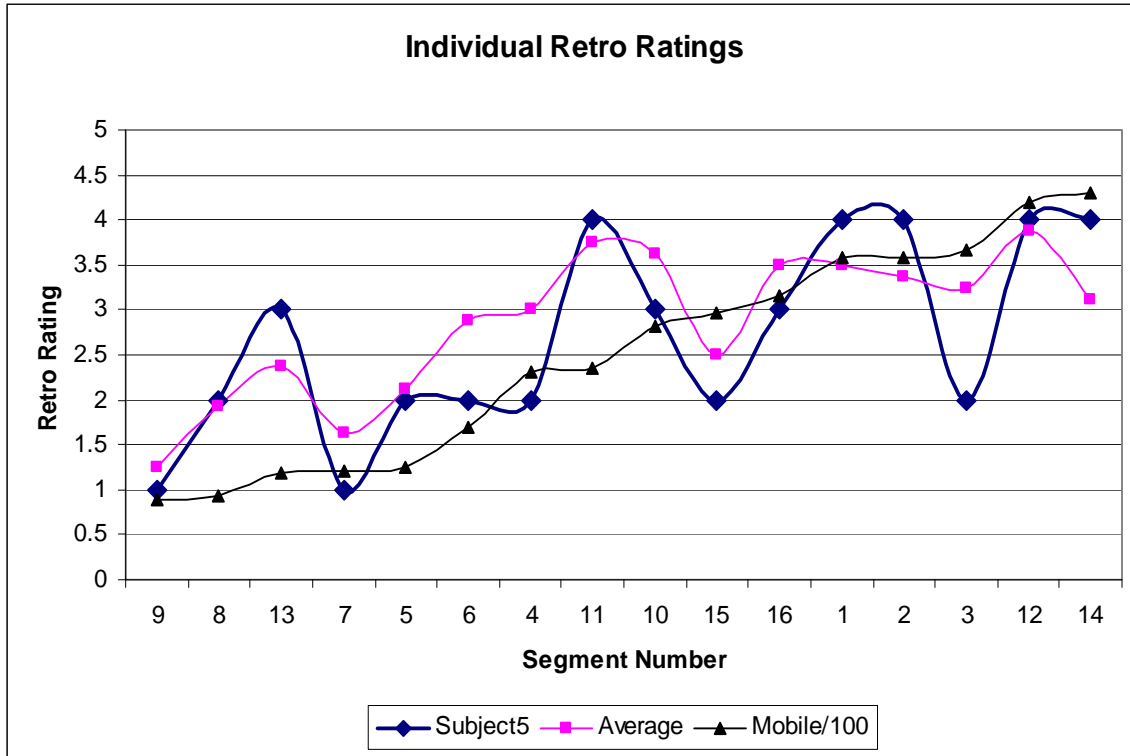

Figure C-6. Individual Retro-Ratings for Subject 6.

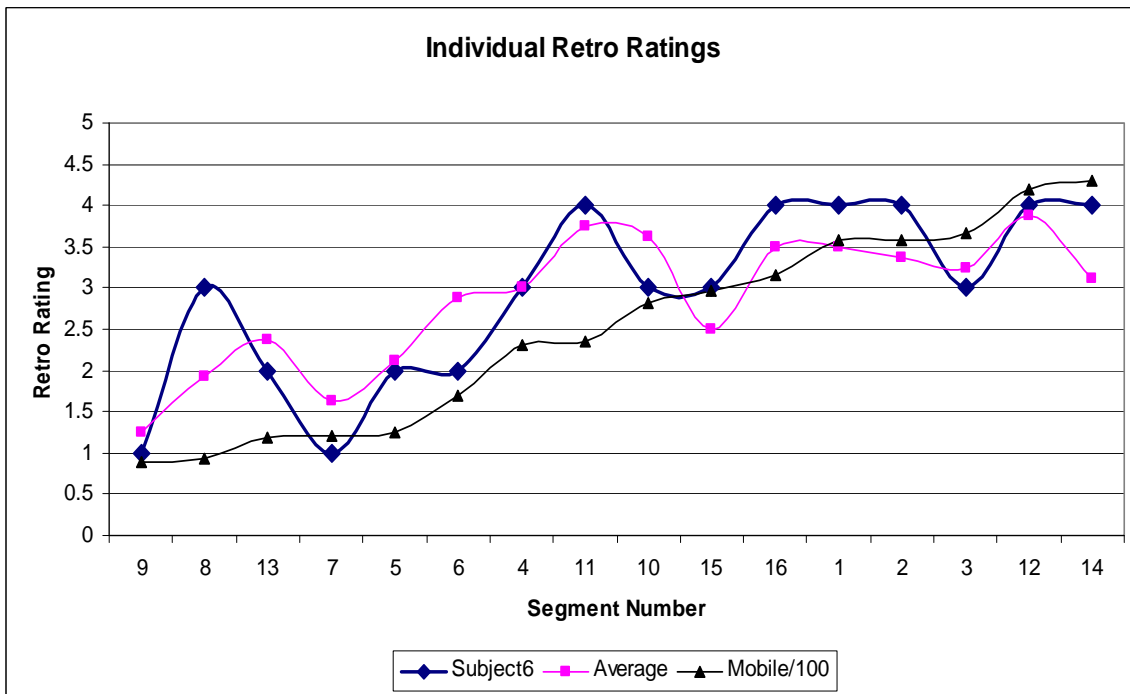

Figure C-7. Individual Retro-Ratings for Subject 7.

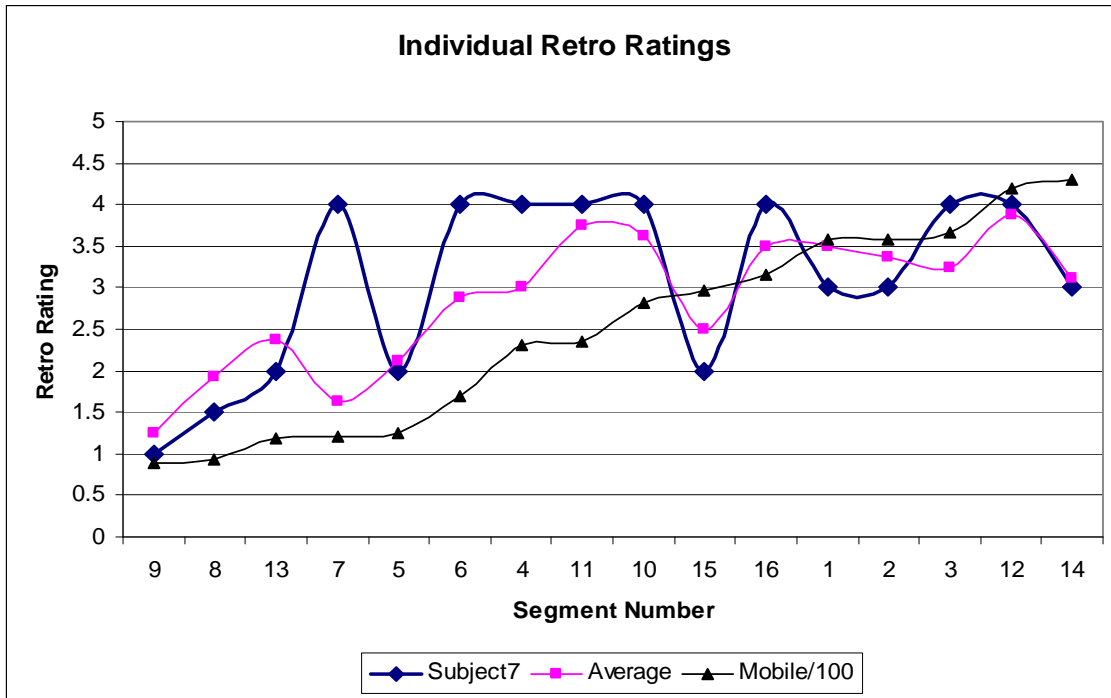
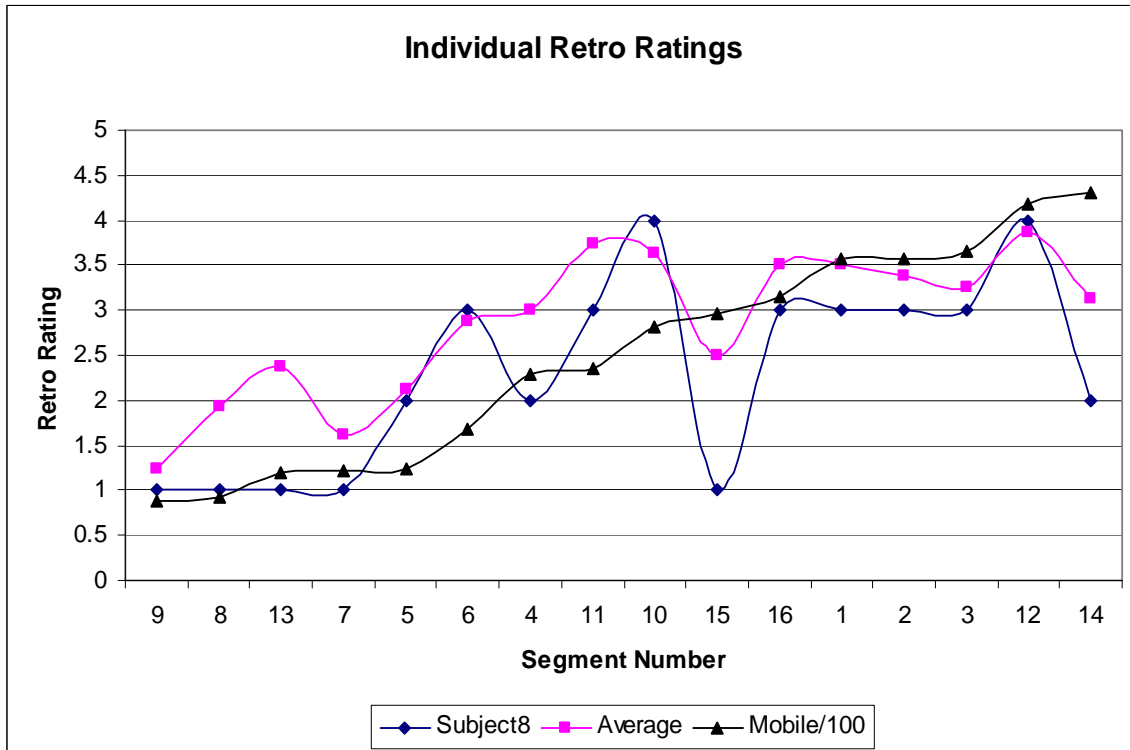

Figure C-8. Individual Retro-Ratings for Subject 8.



APPENDIX D:
**INDIVIDUAL RETROREFLECTIVITY ASSESSMENT BEFORE AND
AFTER TRAINING**

Figure D-1. Retroreflectivity Assessment Graph for Participant 1.

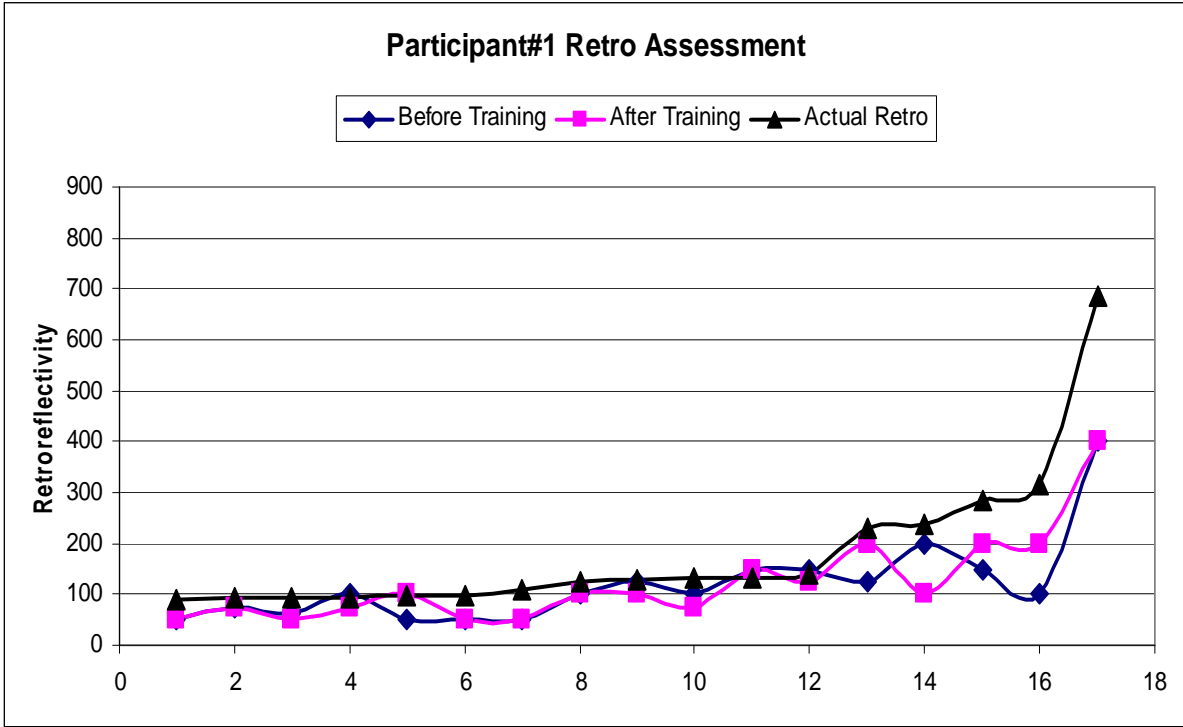

Figure D-2. Retroreflectivity Assessment Graph for Participant 2.

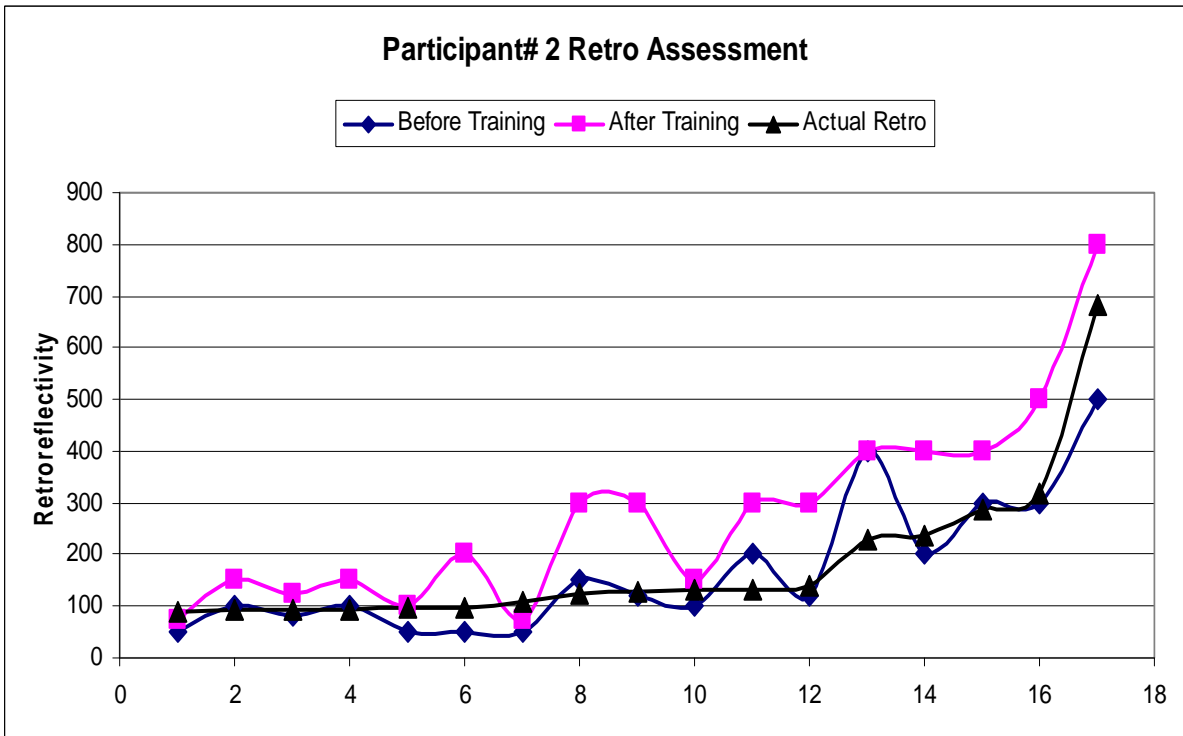

Figure D-3. Retroreflectivity Assessment Graph for Participant 3.

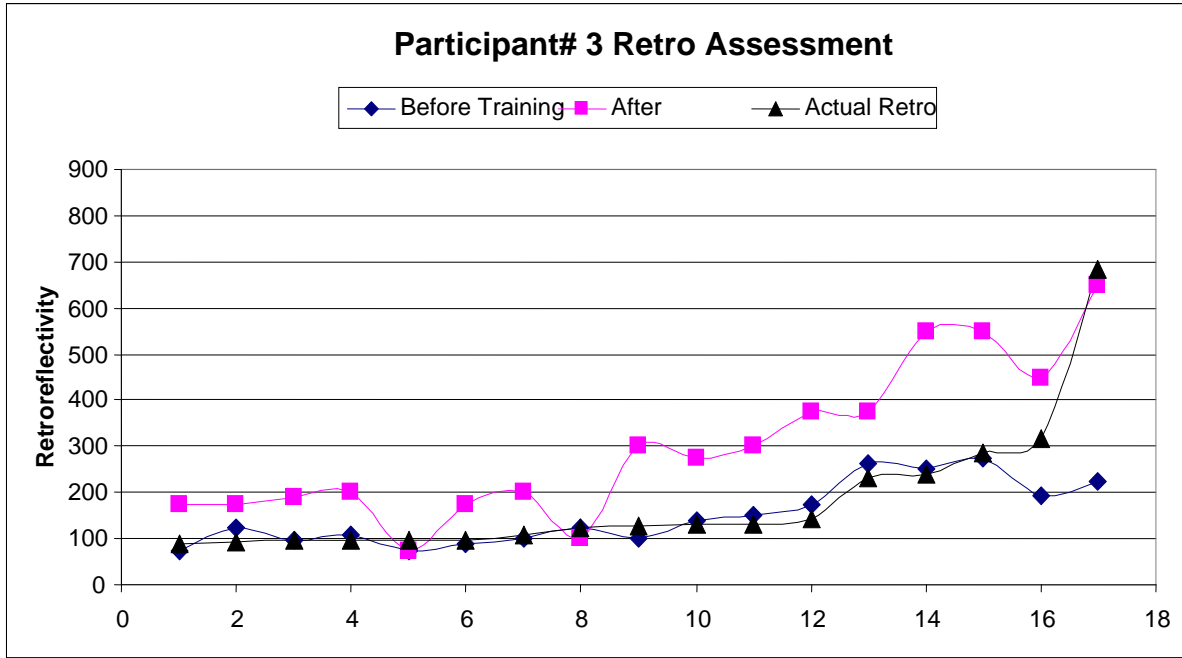

Figure D-4. Retroreflectivity Assessment Graph for Participant 4.

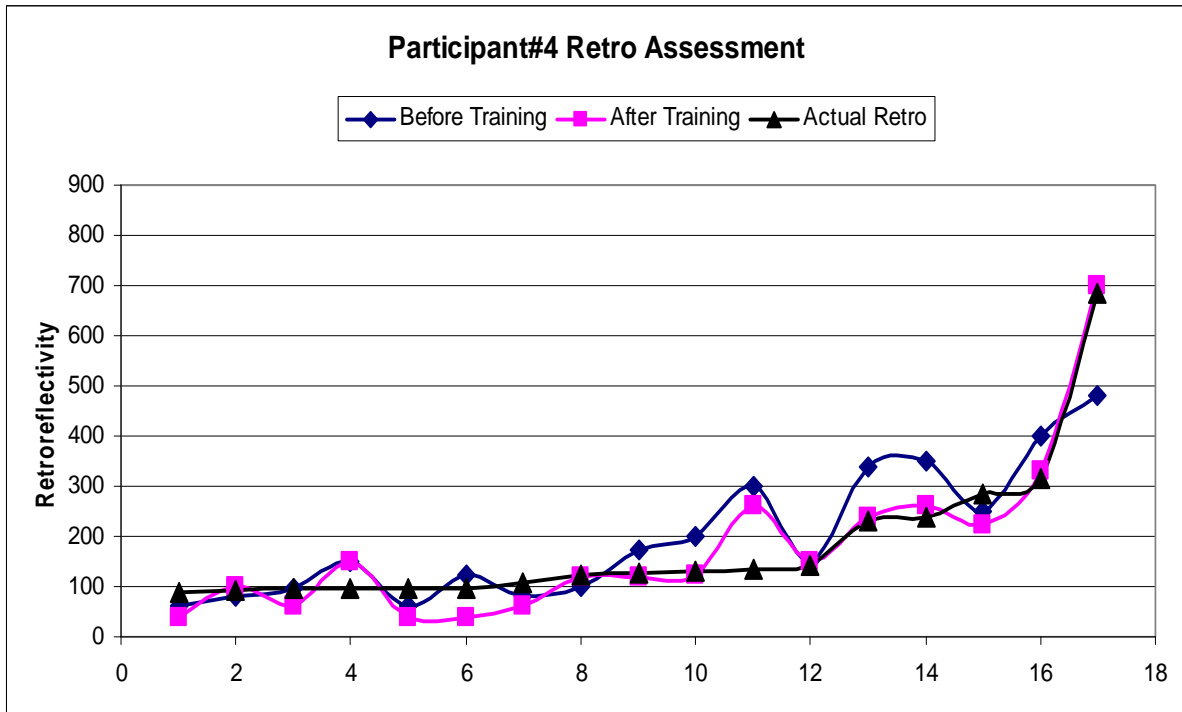

Figure D-5. Retroreflectivity Assessment Graph for Participant 5.

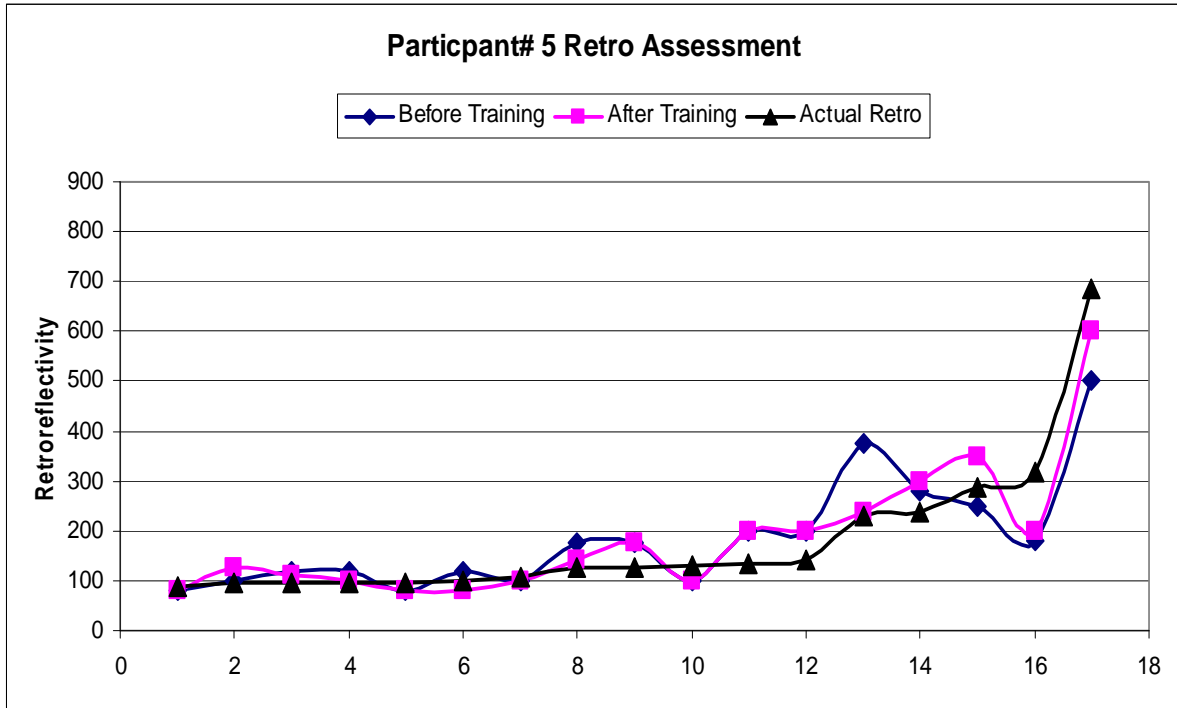

Figure D-6. Retroreflectivity Assessment Graph for Participant 6.

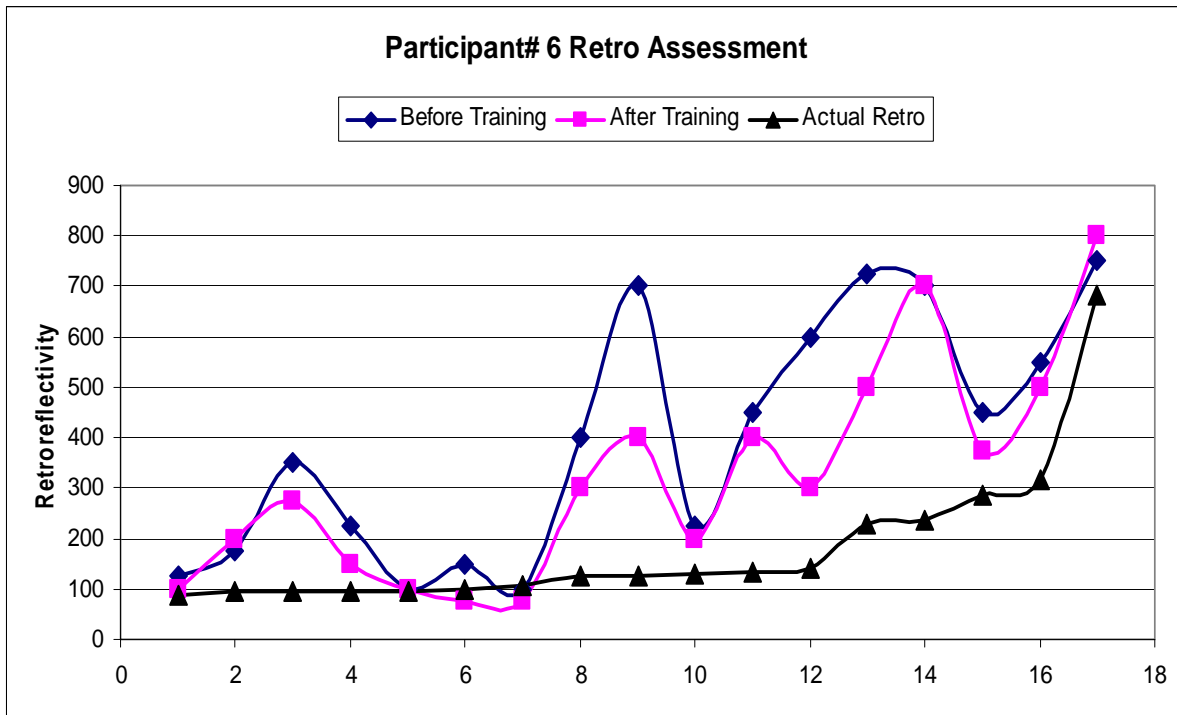

Figure D-7. Retroreflectivity Assessment Graph for Participant 7.

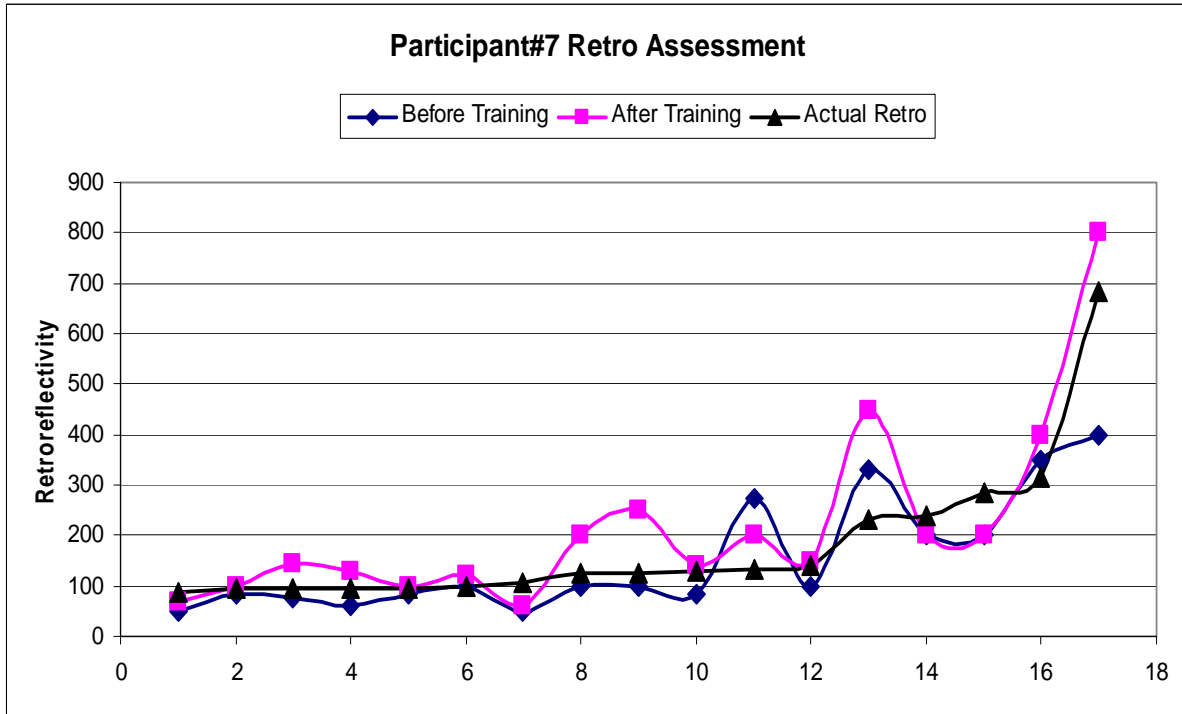

Figure D-8. Retroreflectivity Assessment Graph for Participant 8.

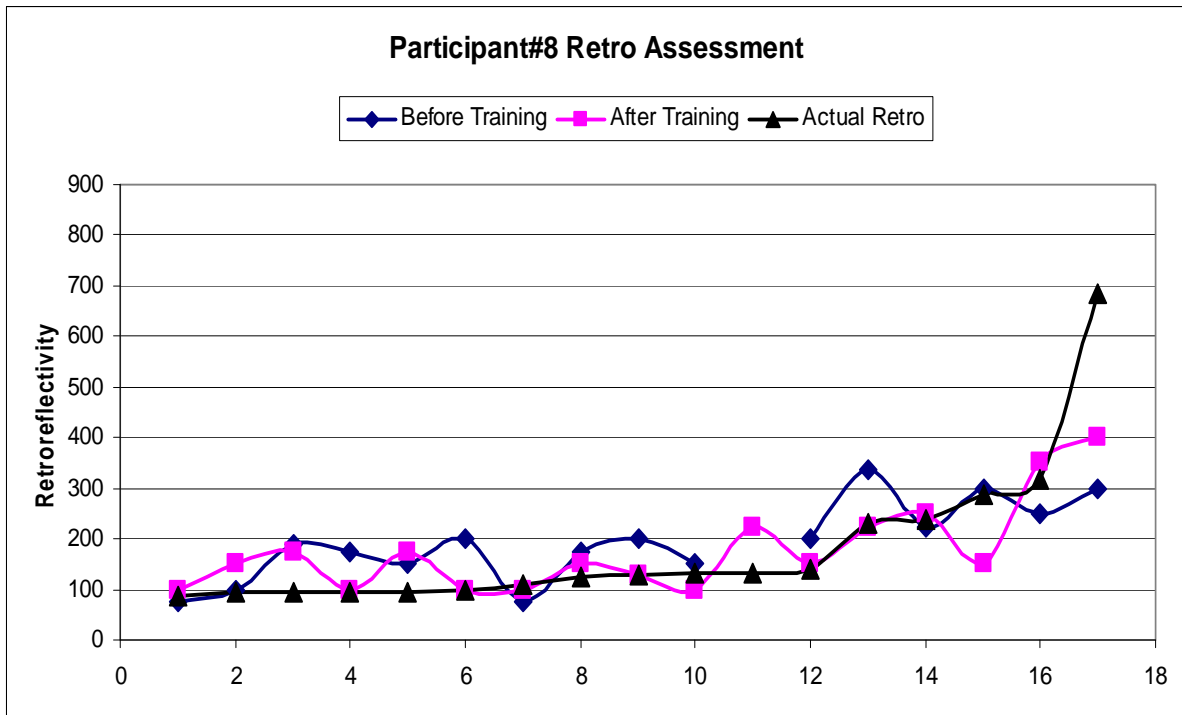

Figure D-9. Retroreflectivity Assessment Graph for Participant 9.

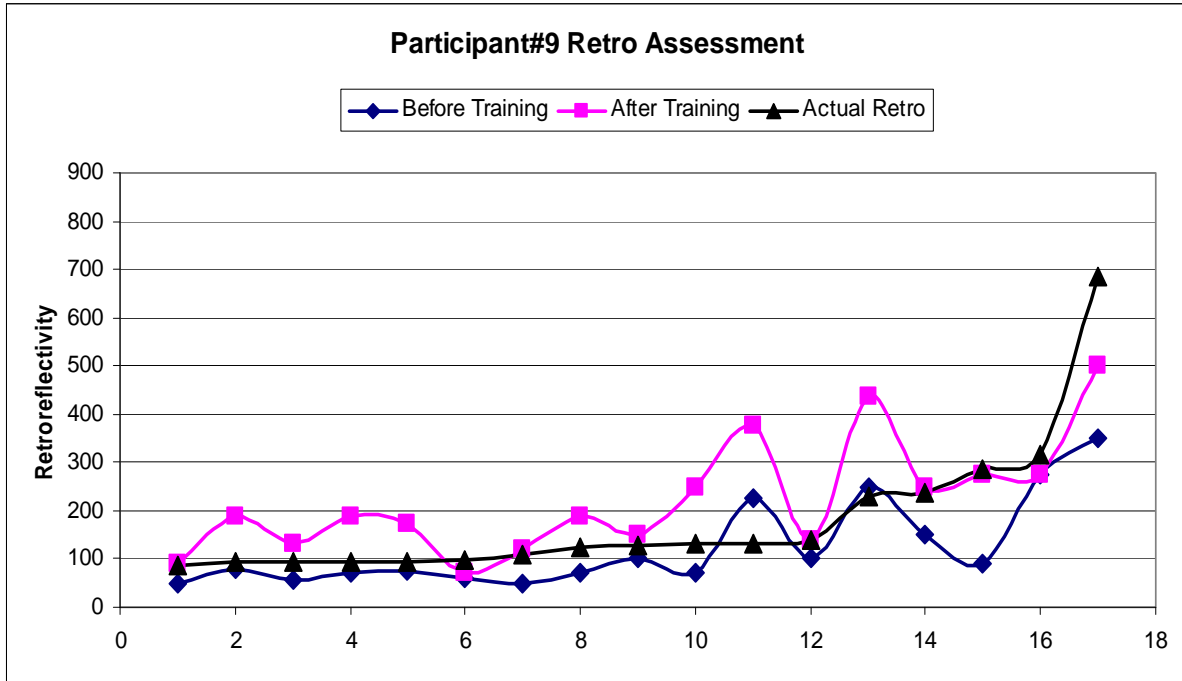

Figure D-10. Retroreflectivity Assessment Graph for Participant 10.

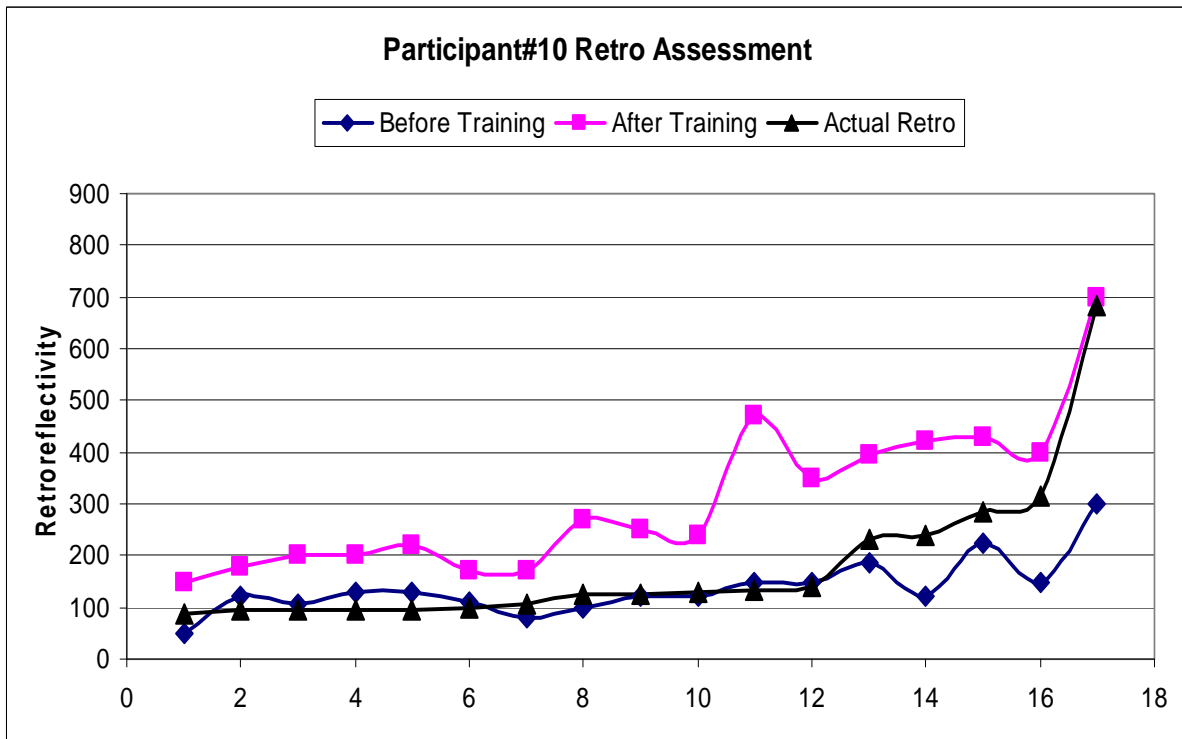

Figure D-11. Retroreflectivity Assessment Graph for Participant 11.

