

1. Report No. FHWA/TX-07/0-5429-1		2. Government Accession No.		3. Recipient's Catalog No.	
4. Title and Subtitle DESIGN CONSIDERATIONS FOR FLEXIBLE PAVEMENT WIDENING				5. Report Date March 2007 Published: April 2007	
				6. Performing Organization Code	
7. Author(s) Stacy Hilbrich and Tom Scullion				8. Performing Organization Report No. Report 0-5429-1	
9. Performing Organization Name and Address Texas Transportation Institute The Texas A&M University System College Station, Texas 77843-3135				10. Work Unit No. (TRAIS)	
				11. Contract or Grant No. Project 0-5429	
12. Sponsoring Agency Name and Address Texas Department of Transportation Research and Technology Implementation Office P. O. Box 5080 Austin, Texas 78763-5080				13. Type of Report and Period Covered Technical Report: September 2005-August 2006	
				14. Sponsoring Agency Code	
15. Supplementary Notes Project performed in cooperation with the Texas Department of Transportation and the Federal Highway Administration. Project Title: Considerations for Flexible Pavement Widening Projects URL: <a href="http://tti.tamu.edu/documents/0-5429-1.pdf">http://tti.tamu.edu/documents/0-5429-1.pdf</a>					
16. Abstract The Texas Department of Transportation, TxDOT, prepared Safety Bond Projects that were to undertake the letting of construction projects for flexible pavement widening on current pavement widths less than 24'. Typically, these projects were approximately 20 foot widths, where widening will extend the pavement width to approximately 27 to 28 feet.  Few guidelines exist statewide for assisting designers in selecting the appropriate widening technique. Current specifications provide a basic framework for construction performance and compaction; however, there are major pavement related issues that are not addressed. Some of these issues include: meeting density requirements on narrow sections, placing the joint in the wheel path, and not matching pavement sections, which can cause moisture to be trapped in the original structure.  To address these considerations and others, this project focused on an extensive literature review and a survey of various district personnel regarding project selection and issues faced during construction of widening projects. This study concluded with a site-specific approach to selection of proper material use and/or re-use, construction technique and traffic control to warrant rapid construction and long-term stability of the widened pavement, which is summarized into a flexible pavement widening guideline.					
17. Key Words Flexible Pavements, Widening, Full-Depth Recycling, Granular Bases, Specifications, GPR, FWD			18. Distribution Statement No restrictions. This document is available to the public through NTIS: National Technical Information Service Springfield, Virginia 22161 <a href="http://www.ntis.gov">http://www.ntis.gov</a>		
19. Security Classif.(of this report) Unclassified		20. Security Classif.(of this page) Unclassified		21. No. of Pages 68	22. Price



# DESIGN CONSIDERATIONS FOR FLEXIBLE PAVEMENT WIDENING

by

Stacy Hilbrich, P.E.  
Assistant Research Engineer  
Texas Transportation Institute

and

Tom Scullion, P.E.  
Senior Research Engineer  
Texas Transportation Institute

Report 0-5429-1

Project 0-5429

Project Title: Considerations for Flexible Pavement Widening Projects

Performed in cooperation with the  
Texas Department of Transportation  
and the  
Federal Highway Administration

March 2007

Published: April 2007

TEXAS TRANSPORTATION INSTITUTE  
The Texas A&M University System  
College Station, Texas 77843-3135



## **DISCLAIMER**

The contents of this report reflect the views of the authors, who are responsible for the facts and the accuracy of the data presented herein. The contents do not necessarily reflect the official views or policies of the Texas Department of Transportation (TxDOT) or the Federal Highway Administration (FHWA). The United States Government and the State of Texas do not endorse products or manufacturers. Trade or manufacturers' names appear herein solely because they are considered essential to the object of this report. This report does not constitute a standard, specification, or regulation. The engineer in charge was Stacy Hilbrich, P.E. (Texas, #94858).

## **ACKNOWLEDGMENTS**

This project was made possible by funding from the Texas Department of Transportation and the Federal Highway Administration. The guidance and technical assistance provided by David Gieber, P.E., the project director, and by John Rantz, P.E., the program coordinator, are greatly appreciated. Additionally, the following people deserve much appreciation for volunteering their time to serve as project advisors:

- Glen Dvorak, P.E.;
- Ralph Condra, P.E.;
- Darlene Goehl, P.E.;
- Bradley Martin, P.E.; and
- Tammy Sims, P.E.

Also, the assistance and guidance provided by Andrew Wimsatt, P.E.; Stacey Young, P.E.; Joe Leidy, P.E.; Mark McDaniel, P.E.; Ricky Boles, P.E.; Darryl Dincans, P.E.; Mykol Woodruff, P.E.; Phil Murphy; Allan Donaldson; and Parker Stewart are gratefully acknowledged.

# TABLE OF CONTENTS

	<b>Page</b>
List of Figures .....	viii
List of Tables .....	x
Chapter One. Introduction .....	1
Chapter Two. Literature Review.....	3
Summary .....	3
Stabilization .....	3
Pavement Edgedrains and Subsurface Drainage.....	11
Longitudinal Construction Joints.....	22
Pavement Edge Drop-Off .....	29
Construction Equipment .....	31
Embankment Widening .....	34
Chapter Three. TxDOT District Survey.....	35
Summary .....	35
Discussion of Survey Results .....	36
Flexible Pavement in Good Condition.....	36
Flexible Pavement in Poor Condition.....	37
Jointed Concrete Pavement.....	40
Chapter Four. Conclusions.....	43
References.....	45
Appendix. Survey District .....	47

## LIST OF FIGURES

Figure	Page
1. Additive Selection for Subgrade Soils (TxDOT 2005a).....	4
2. Additive Selection for Base and Salvaged Existing Material (TxDOT 2005a).....	4
3. Thompson’s Mix Design Flow Chart (Little 1995a) .....	9
4. Map of Texas Counties with Problematic Sulfate Concentrations (Harris, et al. 2004)....	11
5. Typical Edgedrain Configuration (Birgisson, et al. 2000).....	12
6. Painted Arrow Reference Marker (Baumgardner 2002).....	13
7. Outlet Pipe Headwall (Baumgardner 2002).....	14
8. Test Section Configurations for I-94 Project (Hagen & Cochran 1996) .....	16
9. Typical Pavement Sections for I-94 Project (Hagen & Cochran 1996).....	17
10. Typical Cross Section for Pavement with Vertical Moisture Barriers (Ranasinghege, et al. 1992).....	20
11. Density Gradient across Cold-Joint Construction (Foster 1964).....	23
12. Proper Location of the Steel Wheel Roller over the Unsupported Edge of the First Paved Lane (Scherocman 2004).....	24
13. Crack Development in the Mix at the Unsupported Edge of Pavement (Scherocman 2004) .....	24
14. Proper Amount of Overlap from Lane 2 to Lane 1 (Scherocman 2004) .....	25
15. Improper Raking of the Longitudinal Joint (Scherocman 2004) .....	25
16. Proper Placement of Pneumatic Tire Roller on the Hot Side (Scherocman 2004).....	26
17. Proper Placement of Steel Wheel Roller on the Hot Side (Scherocman 2004).....	26
18. Challenge in Longitudinal Joint Construction (NAPA 2002).....	27
19. Taped Joint Technique (NAPA 2002) .....	27
20. Mean Density Profile for Loop 323 in Tyler, Texas (Estakhri, et al. 2001).....	28
21. California’s 1974 Maintenance Standards for Edge Drop-Off (Stoughton, et al. 1979) ...	30
22. Hamm® Model 2220 D ( <a href="http://www.hammcompactors.com">http://www.hammcompactors.com</a> ).....	32
23. Hamm® Model 2222 DS ( <a href="http://www.hammcompactors.com">http://www.hammcompactors.com</a> ).....	32
24. Dynapac CC-122 Tandem Roller ( <a href="http://www.constructionscomplete.com">http://www.constructionscomplete.com</a> ).....	33



## LIST OF FIGURES (Continued)

Figure		Page
25.	Caterpillar CP-323C ( <a href="http://www.cat.com.cda">http://www.cat.com.cda</a> ).....	34
26.	Flexible Pavement Section in Good Condition.....	36
27.	Typical Section for Widening Flexible Pavements in Good Condition .....	37
28.	Flexible Pavement Section in Poor Condition .....	38
29.	Typical Section for Widening Flexible Pavements in Poor Condition Using Full Depth Recycling.....	39
30.	Typical Section for Widening Flexible Pavements in Poor Condition on Highly Plastic Subgrades .....	39
31.	Typical Section for Widening Flexible Pavements in Poor Condition by Reworking the Existing Base.....	40
32.	Jointed Concrete Pavement.....	40
33.	Typical Section for Widening Jointed Concrete Pavements.....	41

## LIST OF TABLES

Table	Page
1. Design Criteria for Selecting Optimal Cement Content .....	6
2. Atterberg Limits after Stabilization with Cement and Lime (Scullion, et al. 2000b).....	6
3. Thompson’s Minimum Strength Requirements for Lime Stabilization (Little 1995a) .....	8
4. MnDOT Requirements for Class 5 Base (Hagen & Cochran 1996).....	17
5. Traffic Control Needs in Construction Zones for Edge Drop-Off Conditions (Lawson and Hossain 2004).....	31
6. Hamm® Model 2220 D Specifications ( <a href="http://www.hammcompactors.com">http://www.hammcompactors.com</a> ) .....	32
7. Hamm® Model 2222 DS Specifications ( <a href="http://www.hammcompactors.com">http://www.hammcompactors.com</a> ) .....	33
8. Dynapac CC-122 Tandem Roller Specifications ( <a href="http://www.constructioncomplete.com">http://www.constructioncomplete.com</a> ) .....	33

# CHAPTER ONE

## INTRODUCTION

The Texas Department of Transportation (TxDOT) prepared safety bond projects that were to be let no later than December 2005. As part of this program, TxDOT undertook the letting of construction projects for flexible pavement widening on current pavement widths less than 24 feet with Average Daily Traffic (ADT) greater than 400. Typically, these projects were to be Farm to Market (FM) roads of approximately 20 foot widths, where widening will extend the pavement width to approximately 27 to 28 feet.

Few guidelines exist statewide for assisting designers in selecting the appropriate widening technique. Currently this work is often specified under, Item 112, “Subgrade Widening,” which governs the construction of the subgrade work, and Item 251, “Reworking Base Courses,” which governs construction of the flexible base widening. These items provide a basic framework for construction performance and compaction. However, the major pavement related issues with widening are as follows:

- Widening can be fairly narrow, say 2 to 4 feet on either side of an existing highway. It is often difficult to get normal compaction equipment to compact this narrow of a strip. Guidelines are required on what equipment is required to adequately complete compaction.
- How can the quality of widened sections be inspected?
- The widened section often becomes the place where trucks’ outer wheels run; any variations in density/quality will be quickly exposed. The widened area should have equal or better structural strength than the existing pavement
- The widening often leaves a vertical construction face between the old and new structure, which trucks run directly over.
- Some districts have experienced problems with widening sections with different base materials. This method can cause a situation where moisture can be trapped in the original structure. Some districts have adopted a “matching cross-section” philosophy; others have not.
- Where and when should stabilization of the existing subgrade be performed? Which stabilizer and what percentage should be used?
- When full-depth reclamation of the existing roadway is used as the first step in the widening process some districts have reported problems with severe longitudinal cracking. These problems have been studied, and some districts have adopted practices to minimize these problems.

Several other design and safety issues exist, such as: tying into existing structures and widening steep side slopes. Again, many districts have developed construction details and special notes to handle these situations.

To address these considerations and others, this project focuses on an extensive literature review, which is discussed in [Chapter Two](#). In addition, researchers conducted a survey of various district personnel regarding project selection and issues faced during construction of widening

projects, and these results are discussed in [Chapter Three](#). This project concluded with a site-specific approach to selection of proper material use and/or re-use, construction technique and traffic control to warrant rapid construction and long-term stability of the widened pavement. As part of Project 0-5429, researchers visited Districts to document what is working and what is not. These findings are summarized into a flexible pavement widening guideline, which is provided in TxDOT Product 0-5429-P2.

## CHAPTER TWO

### LITERATURE REVIEW

#### SUMMARY

A large portion of this project involved an extensive literature review, in which researchers obtained information regarding the various design and construction issues in pavement widening. This chapter provides a detailed summary of the literature review. The review is organized according to the following key areas:

- Stabilization,
- Pavement Edgedrains and Subsurface Drainage,
- Longitudinal Construction Joints,
- Pavement Edge Drop-Offs,
- Construction Equipment, and
- Embankment Widening.

It should be noted that for the purposes of this literature review the units of measure reflect the units used in the referenced reports and are not consistent throughout the chapter.

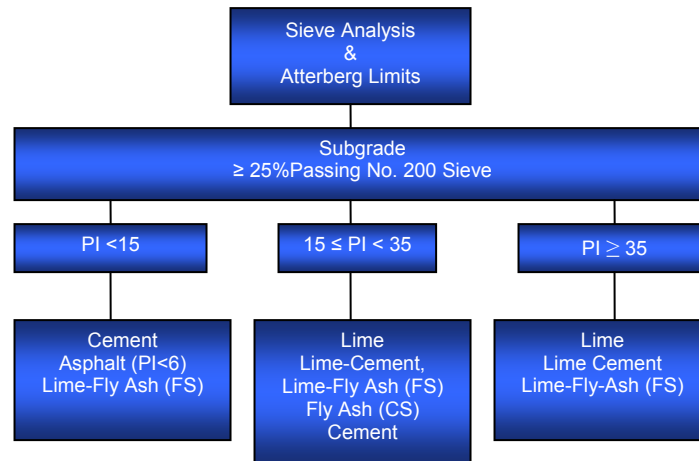
#### Stabilization

*TxDOT (2005a)*

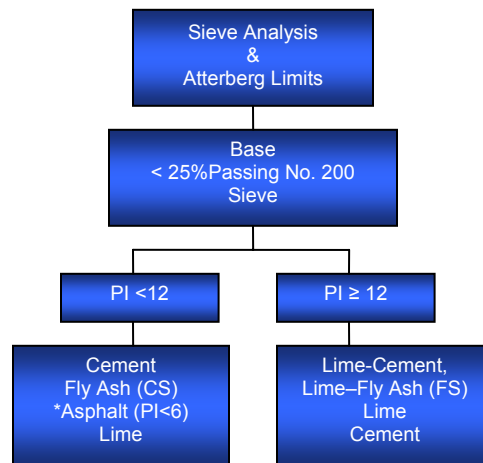
TxDOT's *Guidelines for Modification and Stabilization of Soils and Bases for Use in Pavement Structures* offers a more uniform approach to selecting both the type and amount of stabilizer for subgrades, bases, and salvaged existing materials. A laboratory mix design is a critical step in obtaining the desired improvements to shear strength, modulus, moisture resistance, stability, and durability.

According to the guidelines, the selection of the appropriate stabilizer for subgrades, bases, and salvaged existing materials is dependent on factors, such as: soil mineralogy, soil classification, goals of treatment, mechanisms of additives, desired engineering and material properties, design life, environmental conditions, and engineering economics.

The decision tree shown in [Figure 1](#) offers assistance in selecting a stabilizer for subgrades, given certain soil properties. [Figure 2](#) offers assistance in selecting a stabilizer type for base and salvaged existing materials.



**Figure 1. Additive Selection for Subgrade Soils (TxDOT 2005a).**



**Figure 2. Additive Selection for Base and Salvaged Existing Material (TxDOT 2005a).**

Once the stabilizer type is selected the mix design is the next step to select the appropriate amount of stabilizer. The goals of the mix design are to:

- optimize the percentage of additive used;
- optimize the engineering and materials properties;
- to measure the effectiveness of these materials using moisture conditioning;
- observe the effectiveness of the additive with a specific soil and its mineralogy;
- provide density and moisture control parameters for construction;
- and mitigate cracking and other distresses associated with material behavior.

The mix design process should include:

1. sulfate and organic testing. The presence of either or both of these can be detrimental when stabilizing with certain additives. Sulfate contents should be determined in accordance with Tex-145-E, and organic testing should be conducted in accordance with ASTM D-2974.

2. moisture density curves. The moisture/density relationship for field density control is determined by this. This testing should be conducted in accordance with the governing specification.
3. pH. A high pH environment is required for the soil-lime reaction to occur. Following the procedure of Tex-121-E will aid in determining the minimum amount of lime required to achieve the necessary pH.
4. PI. The plasticity index is commonly used as an indication of a soil's shrink/swell potential.
5. strength testing. This testing should be conducted in accordance with the governing specification.
6. modifier percentage selection. The lowest amount of additive needed to meet the project requirements should be selected.

*Scullion, et al. (2000a)*

Scullion's research for the Portland Cement Association (PCA) details the laboratory test protocol that was developed to allow for the selection of the optimum cement content for soil-cement (S-C) bases that satisfies both strength and shrinkage cracking criteria. Additionally, this study sought to develop a set of selection criterion that would also reduce moisture susceptibility and increase durability.

Six test methods were used to conduct this study. First, samples were prepared and cured for 21 days before being tested for unconfined compressive strength (UCS), which was to serve as a comparison for the UCS after completion of the tube suction test (TST). Samples were prepared and cured for 7 days, dried for 4 days in a 40°C room, and tested for 10 days in TST, for which the surface dielectric was monitored. Samples were prepared and cured for 7 days before being subjected to capillary rise for 10 days to check for moisture-induced deterioration in the stabilized material. Samples were prepared and cured for 7 days, were tested in UCS to failure, and put back in the wet room to cure for 14 more days to check for rehealing of the material. TST was performed on samples that had cured for 28 days, and then were tested in UCS. Shrinkage data were collected on beam specimens for a 20-day period. Finally, the South African Wheel Tracking test was conducted to determine the erosion index.

Researchers conducted testing on three marginal materials that would be stabilized in normal TxDOT usage. The materials selected for this study were a recycled concrete from the Houston District, a caliche from the Pharr District, and a river gravel available in the Yoakum District. The levels of cement that were used in this series of testing were 1.5 percent, 3 percent, and 4.5 percent of Portland type I cement. Untreated samples were also tested to serve as a comparison.

The results of this study produced recommendations for cement stabilizing the three materials tested, and provided a selection criterion by which the optimal amount of cement can be found for base stabilization. For the recycled concrete available in Houston, researchers recommended that no more than 3 percent Portland type I cement be used. The recommendation for the caliche in the Pharr District was to use 3.5 percent cement. Also, at 3 percent cement, the river gravel from the Yoakum District performed acceptably.

UCS was noted to be an important criterion for designing a soil-cement mix, as it provides an indication of load resistance and can be, to a certain extent, correlated to the durability. The TST was found to be a good companion test to UCS because it provides insight to the moisture resistance of the material. The minimal amount of cement that achieves the recommendations shown in [Table 1](#) was suggested as the optimal cement content for a given material.

**Table 1. Design Criteria for Selecting Optimal Cement Content.**

<b>7-Day, Dry UCS (psi)</b>	<b>Final Surface Dielectric (<math>\epsilon</math>) in TST</b>	<b>Retained Strength (TST/Dry Strength Ratio)</b>
$\geq 300$	$\leq 10$	$\geq 100$

*Scullion, et al (2000b)*

This research report was the second of two reports for the PCA, in which the laboratory performance of plastic clay soils stabilized with varying levels of cement and lime were evaluated. Engineering properties, such as Atterburg limits and unconfined compressive strength, were measured. Also, the moisture susceptibility of the samples was determined through the use of the tube suction test. This test was done because field performance studies in Texas indicate that one of the major factors influencing the permanency of subgrade stabilization appears to be the availability of subsurface moisture.

Researchers collected two plastic clay soils from the San Antonio area. Samples were then prepared with each of these soils and were stabilized with 3 percent, 6 percent, and 9 percent cement and 3 percent and 6 percent lime. Samples were also prepared without any stabilization, so that improvements to the soil could be determined.

The Atterberg limits of the soils without any stabilizer were determined, followed by the Atterberg limits for the soils at each level of stabilizer. Both the cement and the lime were shown to effectively reduce the plasticity index of both soils. These results are shown in [Table 2](#).

**Table 2. Atterberg Limits after Stabilization with Cement and Lime (Scullion, et al. 2000b).**

<b>Soil</b>	<b>% Cement</b>	<b>% Lime</b>	<b>Plasticity Index</b>
<b>1</b>	0	0	28
<b>1</b>	3	0	13
<b>1</b>	6	0	10
<b>1</b>	9	0	10
<b>1</b>	0	3	12
<b>1</b>	0	6	9
<b>2</b>	0	0	37
<b>2</b>	3	0	17
<b>2</b>	6	0	12
<b>2</b>	9	0	12
<b>2</b>	0	3	10
<b>2</b>	0	6	13



Samples were also prepared and cured for 21 days before being tested for UCS. Samples were prepared and cured for 7 days, dried for 4 days in a 40°C room, and tested for 10 days in TST, for which the surface dielectric was monitored. These samples were also tested in UCS to check for retained strength. Samples were prepared and cured for 7 days and then were tested in UCS to failure and put back in the wet room to cure for 14 more days to check for rehealing of the material.

There were three criteria used to evaluate the effectiveness of the stabilizer. First, the strengths of the treated soil after a seven-day cure were compared to the strength of the untreated soil. A minimum strength gain of 50 psi was desired. The moisture susceptibility of the samples was monitored using the TST, and a final surface dielectric of 16 was suggested. This value, however, has not been validated for subgrade soils. Also, the retained strength at the end of TST was determined, and a target of 80 percent retained strength was set.

*Guthrie, et al. (2002)*

Guthrie sought to develop a laboratory testing program that could identify the optimum amount of Portland type I cement for stabilizing aggregate base materials. He noted that shrinkage cracking and faulting, which are known to accelerate deterioration of the stabilized material and result in early failure and are common in cement stabilized materials, have led to a decline in the use of cement for stabilization. While unconfined compressive strength (UCS) is the most widely used test method to evaluate cement-stabilized material, this research project with TTI was conducted to evaluate various test procedures to determine the effect of varying cement levels on performance-related engineering properties of aggregate material. These tests evaluated the UCS, shrinkage, durability, and moisture susceptibility of the aggregates stabilized with varying amounts of cement.

During the 1960s, TxDOT specified a minimum strength criterion of 700 psi at seven days for cement-stabilized base material, and thousands of highway miles were constructed that met this criterion. TxDOT experienced severe problems with shrinkage cracking, which caused many districts to abandon cement stabilization in favor of lime or fly-ash. In recent years, lower cement contents have improved long-term performance of stabilized layers, but there is little agreement on the minimum strength requirement.

For the purpose of this research, a minimum threshold of 300 psi was set for the seven-day cure samples to be tested in UCS, and 28-day strengths were also obtained. Durability was measured using the South African Wheel Tracking Test (SAWTET), which simulates stress conditions that are induced by heavy traffic loading. Moisture susceptibility was measured using the TST, for which the dielectric constant is monitored over a 10 day period and is based on an empirical relationship between the dielectric value and the expected aggregate performance. These samples were also completely submerged in water at the end of the TST until a constant weight was obtained and were tested in UCS as well. A retained value of 80 percent of the 28-day UCS was specified as the minimum criterion. Linear shrinkage tests were also conducted.

The result of this research was a testing program that could identify the optimum cement content in a stabilized aggregate that would meet strength requirements, minimize shrinkage, improve

durability, and reduce moisture susceptibility. The criterion that were recommended for cement treated base stabilization design at the conclusion of this study were a minimum of 300 psi for the seven-day UCS, and a maximum average surface dielectrics of less than 10. Also, pre-cracking of cement-treated materials was suggested to occur within one to three days after placement, which should eliminate large shrinkage cracks within the base layer.

*Little (1995a)*

In Little's Handbook for Stabilization of Pavement Subgrades and Base Courses with Lime, three mix design methods for selecting the optimum lime content are discussed. These are the Thompson Procedure, Eades and Grim, and the Texas procedure. Each of these is discussed below.

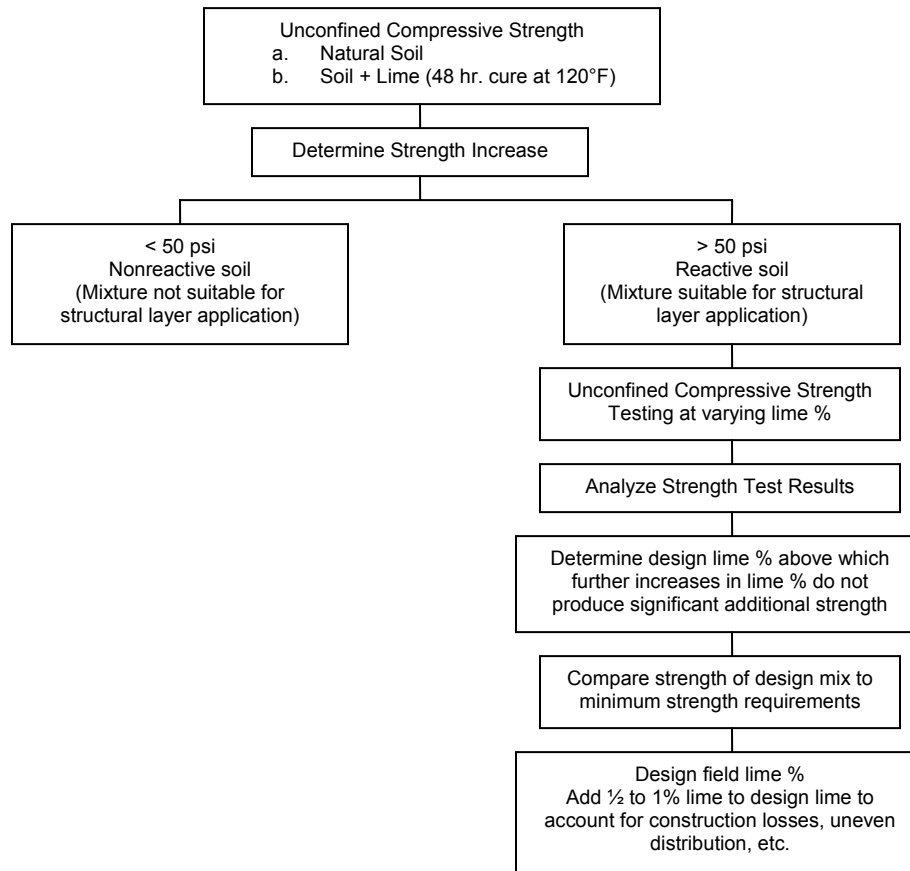
### **Thompson Procedure**

The criteria for the Thompson Procedure depend on the objectives of the stabilization and anticipated field service conditions; however, minimum strength requirements were specified and are shown in [Table 3](#).

**Table 3. Thompson's Minimum Strength Requirements for Lime Stabilization (Little 1995a).**

<b>Layer Type</b>	<b>No Freeze-Thaw Activity</b>	<b>Freeze-Thaw Activity</b>
<b>Base</b>	150 psi	200 psi
<b>Subbase</b>	100 psi	150 psi

Thompson's mix design procedure is shown in [Figure 3](#).



**Figure 3. Thompson's Mix Design Flow Chart (Little 1995a).**

### **Eades & Grim Procedure**

The Eades & Grim Procedure is defined in ASTM D6276. In this procedure, the minimum amount of lime required to produce a pH of 12.4 in the soil-lime mixture is found. This is based on the philosophy that the addition of sufficient lime will satisfy the cation exchange capacity and all initial short term reactions and provide a high enough pH to sustain the strength-producing lime-soil pozzolanic reactions.

### **Texas Procedure**

The Texas method for selecting the optimum lime content for stabilization is defined in Tex-121-E. This procedure uses the chart based on the plasticity index and percent soil binder as well as the pH method described above to find the target lime content. Samples are then prepared and tested for UCS. A minimum UCS of 150 psi for a stabilized base and 50 psi for a stabilized subgrade are suggested.

Little also points out that organic carbon can inhibit the soil-lime reaction and that organic contents greater than 1 percent are cause for concern.

*Little, et al. (1995b)*

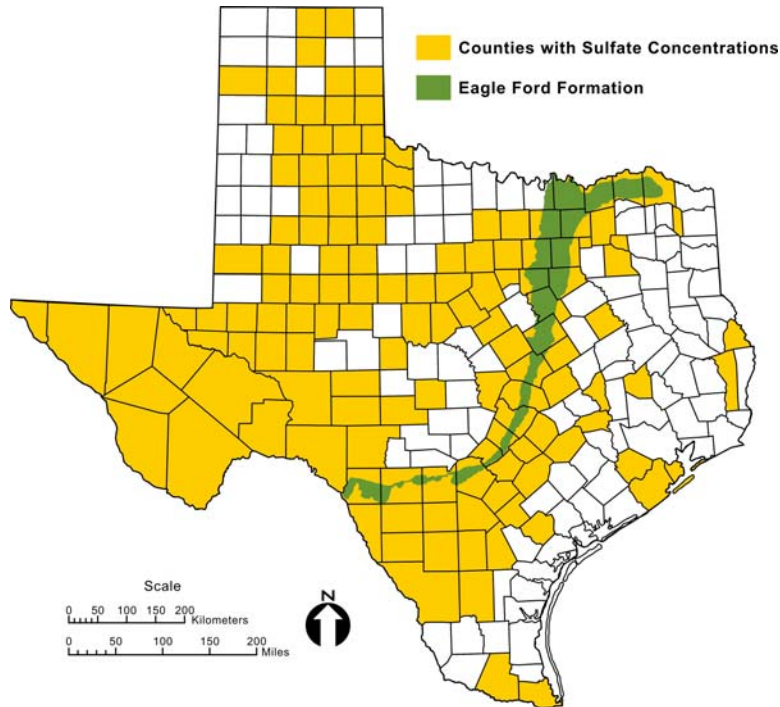
The objective of Little's research was to characterize and evaluate the performance of base and subgrade stabilization of base and subgrade materials in Texas. More specifically, this study sought to: determine realistic levels of strength and in situ moduli as a function of time, determine realistic strength and in situ stiffness or moduli values that could be used for thickness design of lime-treated subgrades, and identify typical failure mechanism of stabilized pavement layers.

Of particular interest is the validation of the stabilization approach employed in the Fort Worth District. For years, the Fort Worth District has lime-stabilized all soils with a plasticity index above 10 with an application of 6 percent lime. The standard practice has been to stabilize 8 inches of subgrade with 6 percent lime, if the plasticity index is less than 30. For PIs greater than 30, the depth was increased to 16 inches.

Researchers tested these pavements with the falling weight deflectometer (FWD) and the dynamic cone penetrometer (DCP), and the moduli and California Bearing Ratios (CBR) were found. The results showed that the stabilized layers in each section were still present and performing, in some cases, after 20 years of service.

*Harris, et al. (2004)*

Soils treated with calcium-based stabilizers will often experience heaving as a result of the chemical reactions with the sulfate and/or sulfide minerals. As such, there were three objectives to Harris' research on lime-stabilization of sulfate-bearing soils in Texas. They were to: assess the 3-D swell potential of lime-stabilized, sulfate-bearing, subgrade soils; determine the sulfate level safe for lime stabilization; and assess the effectiveness of mellowing, double lime application, and increased moisture content in reducing swell in high-sulfate soils. He also identified the counties in Texas known to have problematic sulfate concentrations, which are shown in [Figure 4](#).



**Figure 4. Map of Texas Counties with Problematic Sulfate Concentrations (Harris, et al. 2004).**

For this project varying concentrations of sodium sulfate and gypsum were added to lime-stabilized soil samples, and three-dimensional swell tests were conducted. Also, swell potential was measured for lime/soil mixtures that were mellowed for one to three days before compaction and for lime soil mixtures where the lime was added in both a single and double application.

For the soils tested, researchers made several conclusions and recommendations. These include:

- The use of lime is safe in stabilizing high-PI soils with a sulfate content of less than 3000 ppm.
- For sulfate concentrations between 3000 to 7000 ppm, a mellowing period for up to 3 days should be allowed.
- A single application of the optimum lime content is recommended at 2% above the optimum moisture content.
- An alternate stabilizer should be considered when sulfate concentrations exceed 7000 ppm.

### **Pavement Edge-Drains and Subsurface Drainage**

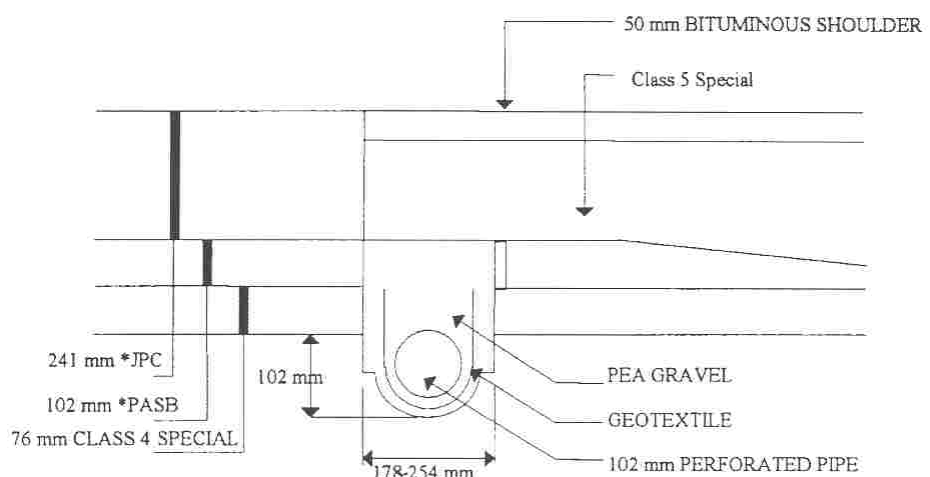
*Birgisson and Roberson (2000)*

Birgisson and Roberson address some design and construction issues in the drainage of pavement base material. The objective of this study was to evaluate the effectiveness of two typical edgedrain configurations. The first configuration was intended to simulate the effects of retrofitting a jointed concrete pavement built over a dense-graded base with edgedrains. The

second was intended to evaluate the actual field performance of a typical edgedrain design that consisted of a blanket of asphalt-stabilized base material, which was connected to the edgedrain.

Data were collected on two sections of pavement at the Minnesota Road Research Project (MnROAD). Each of the two pavement sections studied were 152.4 m in length with 3.66 m lane widths. Pavement 1 consisted of 240 mm of jointed concrete pavement (JCP) over 102 mm of a drained permeable asphalt-stabilized base. Pavement 2 was 240 mm of JCP over 130 mm of dense-graded Class 5 aggregate base. Each section had a 2 percent cross slope.

Longitudinal edgedrains were constructed along the entire length of the test sections using a 100 mm diameter, corrugated and slotted polyethylene pipe that was wrapped in a geotextile fabric. These edgedrains were connected to tipping buckets, which collect water that infiltrates the base material as a result of a precipitation event. The lane-shoulder joint was trenched; the pipe was placed so that the top of the pipe was at the bottom of the base layer, and the trench was backfilled with pea gravel. Base material was then placed over the trench; and the shoulders were graded, sloped, and paved with hot-mix asphalt. A typical edgedrain configuration is shown in Figure 5. Time Domain Reflectometry (TDR) was also used to monitor the volumetric moisture contents of the base and subgrades.



**Figure 5. Typical Edgedrain Configuration (Birgisson, et al. 2000).**

Results for Pavement 1 indicated that the shoulder and centerline locations do not seem to be affected by individual rain events. The shoulder did not show significant signs of wetting up during rain events, but the average moisture content of the shoulder was high at approximately 30 percent. The volumetric moisture content in the outer wheelpath, however, was greatly impacted by even a minor rain event, as it would wet up during the rain event and dry slowly after. From this, researchers conceived that water infiltrated from the surface into the open-graded base material and stayed there rather than entering into the edgedrain system. Thus, inadequate compaction of the material above the edgedrain during construction may adversely influence the performance of the drain.

Results for Pavement 2 indicated that the moisture content at the centerline varied similarly to that of the outer wheelpath with each measured rain event. However, it was noted that the outer

wheelpath stayed wetter than the centerline throughout the test period, which indicated that either the pavement was wetting from the shoulder or the edgedrain system was negatively affecting the flow of water in the outer wheelpath. Only the shoulder seemed to benefit from the edgedrain system because of its proximity to the drain. This situation indicated that retrofitting existing pavements with edgedrains requires careful evaluation and may be used to their full advantage in drainable materials. It was also found that flow through pavement layers must be unimpeded for the drainage system to be effective.

*Baumgardner (2002)*

Baumgardner summarizes the findings of National Cooperative Highway Research Program (NCHRP) Synthesis 285 concerning the importance of continual maintenance and inspection of highway edgedrains. It was stated that “inadequate maintenance is a universal problem” and that “maintenance is critical to the continued success of any longitudinal edgedrain.” The cost to state highway agencies in terms of poor pavement performance is significant for those who do not properly maintain edgedrains. There is indication that plugged subsurface drainage may be worse than no drainage system because the pavement system becomes permanently saturated.

Baumgardner suggested that these drains be inspected at least once a year, and he recommended the use of video equipment to better determine the condition of the drain. Also, vegetation should be mowed from around outlet pipes at least twice a year, and all ditches should be mowed and kept clean of debris. Painted arrows on the shoulders, such as is shown in [Figure 6](#), offer an easier means of locating edgedrain outlets that may be overgrown with vegetation.



**Figure 6. Painted Arrow Reference Marker (Baumgardner 2002).**

The advantages of having larger headwalls for outlet pipes, such as the one shown in [Figure 7](#), was also discussed. The advantages of such a headwall include:

- easier for maintenance personnel to locate,
- vegetation is located farther away from the outlet pipe,
- reduced erosion, and
- prevents cutting/crushing of the outlet pipe.



**Figure 7. Outlet Pipe Headwall (Baumgardner 2002).**

*Fleckenstein and Allen (1996)*

Fleckenstein's 1996 paper documents a study that was initiated in 1991 in Kentucky to determine the effectiveness of various pavement edgedrains on pavement performance. These edgedrains were evaluated based on construction, maintenance, performance of the backfill and geotextile membranes, and the lateral effectiveness across the pavement structure.

Construction was evaluated using site excavations, borescopes, and push-type mini-cameras. Researchers found that 20 percent to 30 percent of the edgedrain outlet pipes that were inspected had been crushed during installation. Many of the drain pipes had sags or had been installed at the wrong grade, which allowed for the accumulation of debris in the pipes. Also, a significant amount of crushing was observed when the sand backfill had not been properly compacted and traffic had been allowed to travel over the trench during construction.

Maintenance was evaluated through the inspection of 239 edgedrain outlets. Researchers found that 55 percent of the outlets were clean, while the remaining 45 percent were either partially or completely plugged by grass, rock, and other debris.

Evaluation of the backfill and geotextile membranes was accomplished through excavation, gradation analysis, permeability testing, and microscopic analysis. Results indicated that the sand backfill material appeared to effectively filter out the minus #200 material and kept it from flushing into the geotextile filter fabric. It was also determined through the use of a microscopic analysis that using a sand backfill caused only a minimal amount of clogging of the fabric.

The lateral effectiveness of edgedrain systems across the pavement structure was evaluated using subgrade moisture contents, which were used as an index of effectiveness of lateral drainage. Samples were obtained on sections of pavement with and without edgedrains and were taken at the outside shoulder interface, at the right wheel path, between the wheel paths, at the left wheel path, and at the centerline. The moisture data were then normalized to the highest moisture content at each location. The comparison between the pavements with and without edge drains showed that the subgrade moisture at the shoulder was approximately 28 percent lower for sites with edgedrains than without.



To answer the question of whether or not edgedrains actually increase the performance life of a pavement, FWD testing was conducted to determine the subgrade strength. Also used to analyze pavement performance was the ride index (RI), which was obtained from the Pavement Management Branch of the Kentucky Department of Highways.

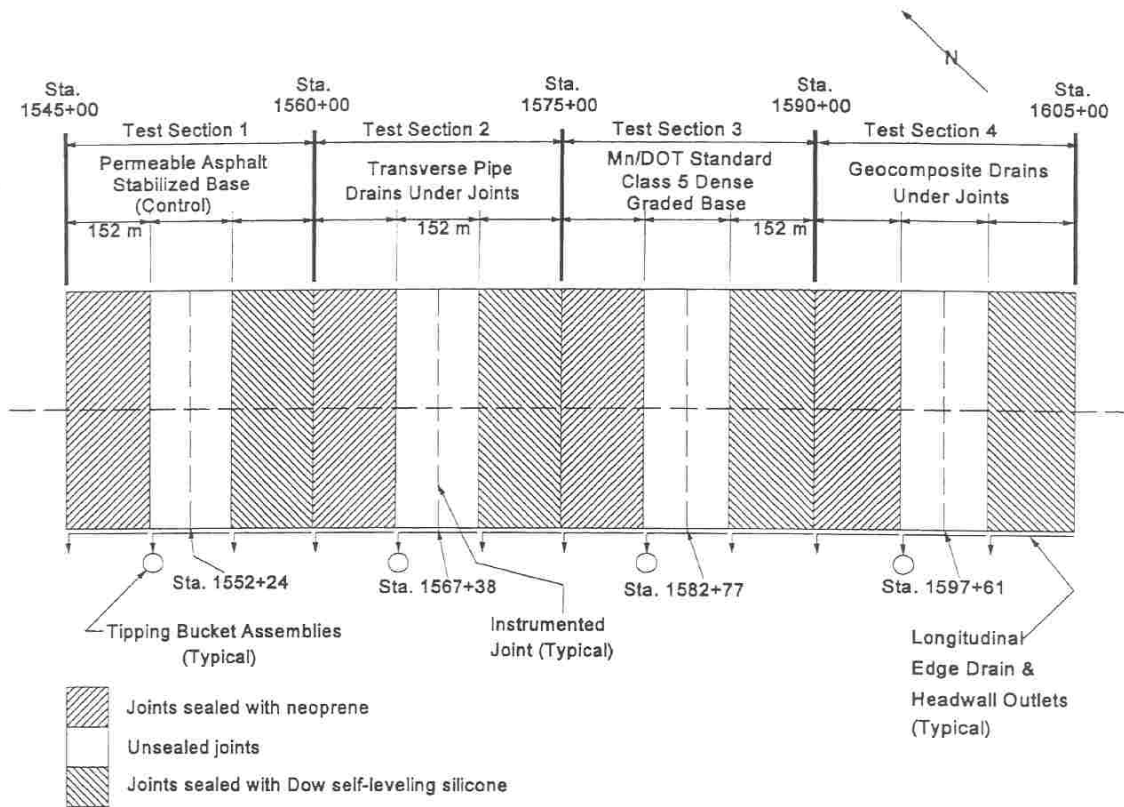
FWD tests were performed on pavement sections both before and 2 years after installation of edgedrains and on some sections that had recently had drains installed and others that had none. For the sections that were tested before and 2 years after installation of edgedrains, an increase in the average subgrade moduli was found after the installation. This increase in subgrade strength was attributed to the edgedrains. Also, the sections of pavement with recent (2 weeks prior) installation of drains showed an 18.5 percent higher subgrade modulus than those sections that had no edgedrains, which was also attributed to drainage provided by the edgedrains.

Plots of the RI were normalized for years before installation of edgedrains and years after installation. Although there was some scatter in the data, it was clear that there was a sharp diversion between the two lines after the edgedrains were installed, which is an indicator of improved pavement performance. The results of this part of the analysis showed that the earlier edgedrains were installed, the better the pavement performance would be.

Several recommendations were made at the conclusion of this study. First, researchers suggested that the edgedrains and the outlet pipe be inspected after installation using a borescope or miniature pipeline camera and that if problems like sagging or coupling occur, then consideration should be given to the use of a more rigid pipe, like 40 PVC. Also, 8 to 10 inches of dense-graded aggregate should be placed under the outlet headwalls to increase foundation strength. Lastly, it was recommended that the headwall trough, screen, and ditch lines be inspected and cleaned at least twice a year.

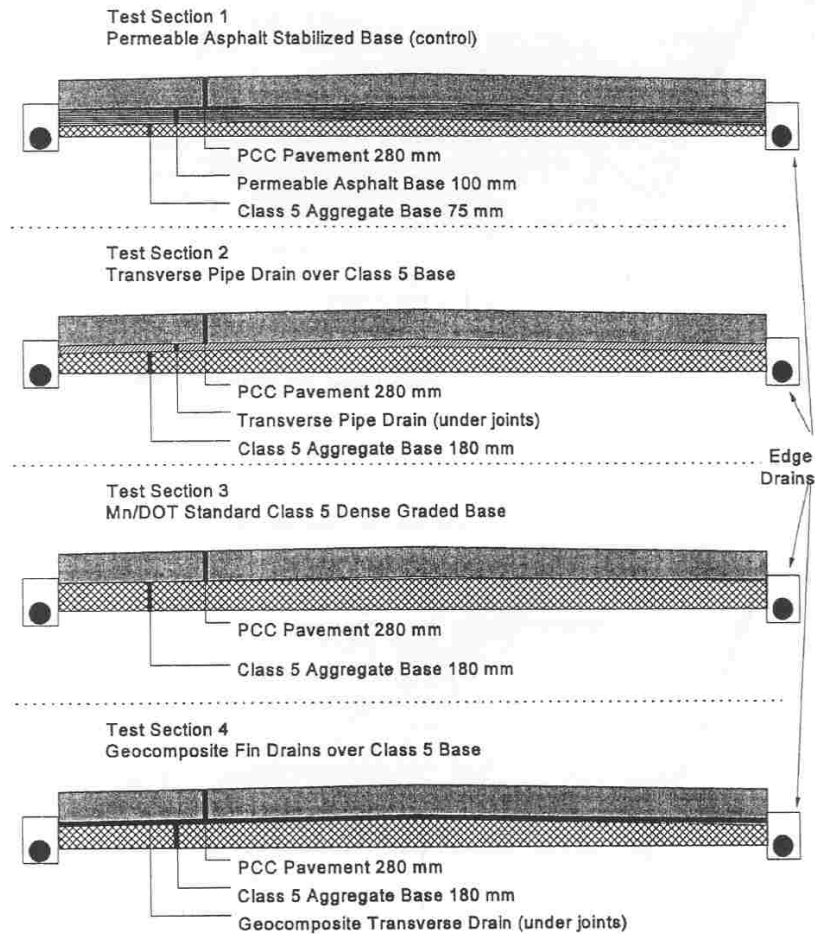
#### *Hagen and Cochran (1996)*

The objective of Hagen's report was to evaluate the relative performance of various drains and their effect on pavement performance. The project included the construction of four drainage test sections along I-94 in two counties in Minnesota. Each section was 457 m long and joints were spaced at 8.2 m, which were further divided into three subsections that were 152 m in length as is shown in [Figure 8](#).



**Figure 8. Test Section Configurations for I-94 Project (Hagen & Cochran 1996).**

Each test section constructed consisted of 280 mm of Portland cement concrete (PCC) over a permeable base. Typical pavement sections for this project are shown in Figure 9.



**Figure 9. Typical Pavement Sections for I-94 Project (Hagen & Cochran 1996).**

Section 1 was used as a control section and consisted of 280 mm of PCC over 100 mm of permeable asphalt stabilized base over 75 mm of Class 5 dense-graded base, which served as a filter layer. This section was built in accordance with typical Minnesota Department of Transportation (MnDOT) standards for pavement subsurface drainage. The gradation requirements for Class 5 base are listed in Table 4.

**Table 4. MnDOT Requirements for Class 5 Base (Hagen & Cochran 1996).**

Sieve Size	Percent Passing
25.0 mm (1 in.)	100
19.0 mm (3/4 in.)	90-100
9.5 mm (3/8 in.)	50-90
4.75 mm (#4)	35-80
2.0 mm (#10)	20-65
425 μm (#40)	10-35
75 μm (#200)	3-10

For Section 2, the 100 mm of PASB was replaced with 100 mm of Class 5 material with transverse interflow channels being placed below each transverse joint. The channels consisted

of 38 mm diameter perforated plastic pipe with 98 perforations per meter. The top of the pipe was 25 to 50 mm below the top of the dense grade material and was backfilled with seal coat aggregate. Section 3 was 280 mm of PCC over 180 mm of Class 5 base with no transverse drains or permeable base material. Section 4 included a geocomposite fin drain, which was made of an inert-plastic permeable core that was 150mm wide by 13 mm thick encapsulated in a geotextile sleeve. These drains were placed flat below the transverse joints. Tipping buckets were connected to the drainage pipe at the headwalls and were used to measure the amount of water that flowed through the drainage system.

From 1990 to 1994, the amount of drainage through the tipping buckets was recorded, as well as the amount of rainfall. Although there was some variability in the data, drainage through the geocomposite fin drain was the greatest, followed by the PASB, then the MnDOT Class 5 base, and finally, the transverse pipe drains.

TDRs were also used to monitor the base and subgrade moisture contents. The TDRs were placed 0.3 m from the centerline and 0.3 m from the shoulder. Readings at the centerline were constant at 4.2 percent and were supported by a laboratory analysis. The moisture content tended to be much higher in the Class 5 base and subgrade, but the base was somewhat drier in the sections with the transverse drains. Although the open-graded and geocomposite fin drains drained the water most rapidly, the PASB seemed to drain the most water and provided the driest pavement foundation.

#### *Wells and Nokes (1993)*

Wells paper details the evaluation of 26 projects in California in which edge drains were retrofitted. This evaluation was spurred by the fact that accelerated cracking was observed on many of these projects, which required an earlier than expected need for further rehabilitation.

The pavements investigated were 203 mm or 229 mm thick jointed plain concrete pavements (JPCP) that were non-reinforced and non-dowelled. These pavements had random joint spacings and were built on cement treated bases that were 101.6 mm to 152.4 mm thick. A database was developed to establish the structural condition of all 26 pavements at the time of edge drain construction. The data base included other relevant information, such as: project location, service life prior to drain installation, mean percentage of first and third stage cracking, accumulated equivalent single axle loads (ESAL) between construction and rehabilitation, average annual rainfall, and average annual heating and cooling degree days. (First stage cracking was defined as having no intersecting cracks, and third degree cracking was defined as a fragmented slab. A heating degree is given for each degree that the average daily mean temperature falls below 65°F, and a cooling degree is given for each degree that the average daily mean temperature is above 65°F.)

A statistically significant correlation was found when third stage cracking was modeled as a function of first stage cracking. On 11 of the 26 projects that failed, it was found that a higher amount of both first and third stage cracking were present prior to installation of the edgedrains. Environmental conditions were found to significantly affect the performance of the JPCP, with

higher annual rainfall present in the failed sections. Also, higher heating degree days were higher at failed projects.

Researchers concluded that the amount of third stage cracking prior to retrofitting edge drains is a critical factor in subsequent pavement performance. It was also concluded that the rate and variation of heating may be more important than thermal gradients within the pavement and should be considered in addition to the amount of rainfall.

### *NCHRP (2002)*

The NCHRP report from the Research Results Digest presents key findings from NCHRP Project 1-34, “Performance of Subsurface Pavement Drainage,” in which the effects of subsurface pavement drainage on the performance of asphalt concrete (AC) and Portland cement concrete are summarized. The key questions addressed in Project 1-34 were:

- Do the various subsurface drainage design features contribute to improved performance of flexible (AC) and rigid (PCC) pavements?
- Are the features cost-effective, and under what conditions?

There is a long history of the problems associated with the design and construction of drainage features, like permeable bases, longitudinal edgedrains, transverse drains, daylighted permeable bases, and retrofitted edgedrains of pavements. Some of these problems include: permeable bases may become infiltrated with fines from underlying layers, as well as construction difficulties and early cracking of permeable bases, lack of proper functioning of edgedrains, and settling of retrofitted drains.

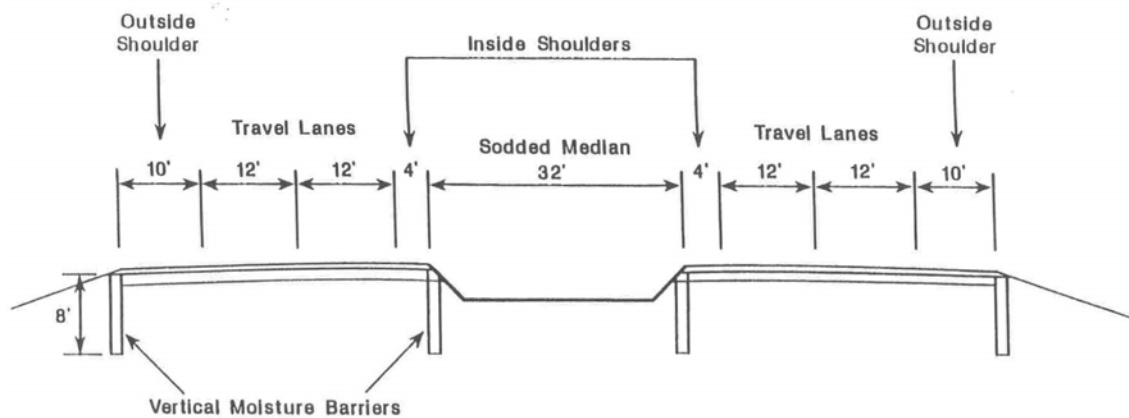
To address some of these issues, Project 1-34 analyzed data that were collected from 91 flexible pavement sections at 22 project sites in 10 states and the province of Ontario, Canada as well as 46 rigid pavement sections at 16 project sites in seven states and in the province of Ontario. Additionally, data were gathered for more than 300 flexible and rigid pavements from the Federal Highway Administration (FHWA), Rigid Pavement Performance/Rehabilitation (RPPR), and Long-Term Pavement Performance (LTPP) databases. The analysis included: comparing the performance of drained and undrained sections, developing a mechanistic-empirical model for fatigue cracking and rutting of flexible pavements and joint faulting of rigid pavements, and performing a life cycle cost analysis.

Results for this study indicate that permeable bases have the potential to increase pavement life, but this is very dependent upon the design conditions and site conditions. For the flexible pavements, researchers concluded that thicker layers of asphalt-treated bases and full-width paving is more effective at preventing moisture infiltration. Also, it was highly recommended that a granular layer be placed below the dense AC layer to avoid a bathtub effect. For the rigid pavements, a widened lane with a permeable base was cost-effective and had the potential to reduce joint faulting as well as improve the durability of the concrete slab. It is critical, however, that construction and maintenance issues be considered when designing subsurface drainage because neglecting to maintain the drainage system could lead to more rapid failure of the pavement.

Ranesinghege, et al. (1992)

Ranesinghege's paper summarizes the results of a five-year study, in which vertical moisture barriers were installed at 11 pavement test sections located at six sites in three different climatic zones in Texas to determine the effectiveness of the moisture barriers in controlling roughness of pavements built over expansive clay subgrades. Other objectives for this study included recommending suitable moisture control installations for various drainage, soil, and climatic conditions and suitable site investigation practices for the design of vertical moisture barriers.

To accomplish the first objective, vertical moisture barriers were installed along both edges of the pavement at eight test sections, and either calibrated thermal moisture sensors or thermocouple psychrometers were installed at different depths in the subgrades both inside and outside of the moisture barriers. A typical cross section for a pavement with vertical moisture barriers is shown in Figure 10. Laboratory testing was conducted on disturbed soil samples from all the test sites to characterize the subgrades. Also, profilometer readings were taken bi-annually to monitor the development of pavement roughness.



**Figure 10. Typical Cross Section for Pavement with Vertical Moisture Barriers (Ranesinghege, et al. 1992).**

Profilometer measurements were taken on both the sections with moisture barriers and on control sections located adjacent to these without moisture barriers. The Serviceability Index, International Roughness Index, and the maximum expected bump height were estimated for each day that measurements were taken.

Results from the laboratory characterization of most of the soils in this study had more than 90 percent passing the No. 200 sieve, with a majority of the soils being classified as either marginally or highly active soils in terms of swell potential.

Site conditions that were considered for this study included: soil type and how permeable it was, drainage type, root depth, and whether medians were paved or sodded. The maximum vertical movement that could be expected from these soils was estimated for pavements with and without moisture barriers and was plotted against the Thornthwaite moisture index (TMI) for

comparison. The TMI is a number that indicates the moisture condition at a particular location and is calculated on an annual basis of precipitation, potential evapotranspiration, and depth of available moisture using [equation 1](#):

$$TMI = \frac{100R - 60DEF}{E_p} \quad (1)$$

where:

R = Runoff moisture depth

DEF = Deficit moisture depth

Ep = total potential evapotranspiration for the year

These results showed that the maximum movement occurred in sites where the TMI is approximately -10 and that vertical movement decreases when the TMI deviates from this value. The results showed the vertical movement increased with increasing unsaturated permeability. In general a decrease in vertical movement was to be expected with increasing moisture barrier depth, and pavement roughness was significantly reduced when a vertical moisture barrier was present.

Vertical moisture barriers are not ideal for all conditions, however. Researchers suggested that vertical moisture barriers are effective in expansive soils only when medium cracked soil are present and are ineffective in cracked soils under any drainage condition. Also, moisture barriers are ineffective in semi-arid climates under ponded drainage conditions and in tight subgrade soils in any drainage condition. The depth of the barrier should be greater than the depth of the root zone, which is typically about 8 feet deep.

Proper placement of vertical moisture barriers is critical for effective performance. The fabric should be placed at the inside edge of the excavated trench. The trench should then be backfilled with a graded material, which is ideally a lightweight aggregate. Sand has been found to be a poor backfill material as it tends to settle. An impermeable asphalt concrete layer should be placed over the pavement and extended beyond the barrier. All joints should be properly sealed to prevent water infiltration, and cracks in the pavement should be sealed immediately.

*Bredenkamp, et al. (1999)*

In 1998, Bredenkamp et al. evaluated the performance of vertical moisture barriers placed along IH 45 near Palmer, Texas. These barriers were installed by cutting a 10 inch wide trench 8.2 feet deep. The moisture barrier, which was a thick polypropylene fabric, was placed against the inside edge of the trench and backfilled with sand and sealed at the surface.

To monitor the moisture variations both inside and outside the moisture barriers, moisture measurements were taken from 1996 to 1998 using the Troxler Sentry 200-AP moisture measurement device. This device measures the soil dielectric constant, which is related to the volumetric moisture content. To be effective, the moisture inside the barrier should vary less than the moisture outside the barrier.

Three methods of analysis were used to evaluate the volumetric moisture content data collected at various depths throughout the soil profile. These methods included: a graphical analysis in which the moisture data were graphed for each site, a statistical analysis for which the standard deviation at each site was determined, and a laboratory analysis for which the field results for each site were verified.

As a result of these three methods of analysis, researchers determined that the vertical moisture barriers were effective at reducing the soil moisture variability inside the barrier for three of the four test sites. For the one site in which the barriers did not effectively control moisture variability, a sand seam was noted to have been encountered during construction. It was, therefore, recommended that the barrier be removed.

Several conclusions were drawn at the end of this study. Some of these include:

- Soil moisture variability is significantly less inside the barrier.
- Utilization of select materials in construction also reduces soil moisture variability.
- Soil moisture generally decreases with depth.
- Soil moisture levels inside the barrier are less influenced by rainfall.
- Abnormal weather conditions, such as drought, can cause increased moisture variability.

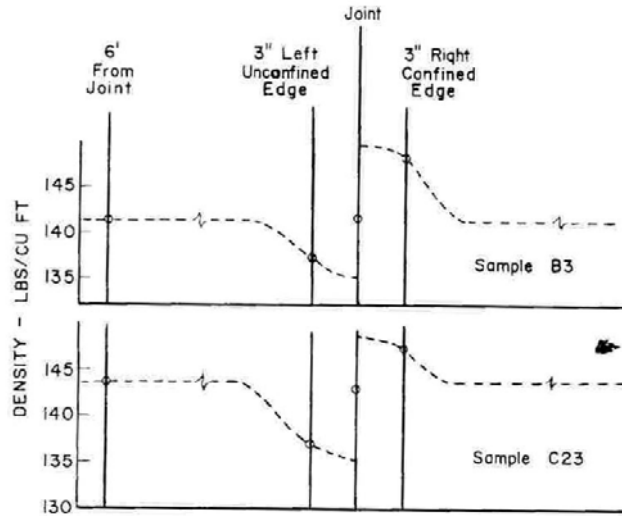
## **Longitudinal Construction Joints**

### *Foster (1964)*

Foster's 1964 paper reports the results of density and tensile strength tests on samples cut from longitudinal joints in hot-mix asphaltic pavements that were constructed using various techniques, including: hot joints, semi-hot joints, and cold joints. Samples were taken along the joints in 12-inch square sections from pavements laid under normal conditions in Maryland and North Carolina. Each 12-inch square sample was then cut into six 3-inch square coupons and one 3 inch x 9 inch coupon for testing. Samples were also taken 6 feet on either side of the joint for comparison.

Foster used the 3 inch square coupons to determine densities, and the 3 x 9 inch coupons were used to find the tensile strength. Results for this investigation showed that a low density zone at the edge of the initial lane and a high density zone at the edge of the subsequent lane were not present in the hot joints constructed with pavers operating in echelon, but were present in cold-joint construction. This density gradient is shown in [Figure 11](#).





**Figure 11. Density Gradient across Cold-Joint Construction (Foster 1964).**

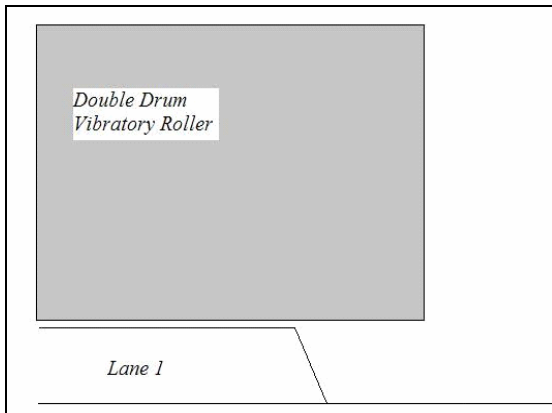
The density gradient also showed that overlapped rolling produced the highest densities in semi-hot joint construction. There was no superior procedure used in cold-joint construction, although infrared heating did improve density slightly in the initial lane. This method did not improve tensile strength. Tacking the edge of the joint did not improve tensile strength, either.

Foster concluded that rolling a bituminous surface in a plastic state without edge confinement cannot produce the required density. An area of low density and tensile strength is left in an area extending from the joint to an unknown distance when the pavement in the initial lane cool before the adjoining lane is placed. It was suggested that some form of confinement, edge compaction, infrared heating, or a combination of these may be the solution.

*Scherocman (2004)*

Scherocman details the steps necessary to successfully construct a longitudinal joint, and he also notes some common causes for failure at the joints. He stated that there are four tasks that must be accomplished in order to properly construct a longitudinal joint. These are: compacting the unsupported edge of the first paved lane, overlapping the mix of the second lane over the top of the first, raking the mix off of the first lane, and compacting the joint between the two lanes.

For successful compaction of the unsupported edge of the first paved lane, the type and position of the roller is critical. Scherocman states that a pneumatic tire roller normally cannot be used within about 6 inches of the unsupported edge of the lane without pushing the material sideways. He suggests that a steel wheel roller, either in vibratory or static mode, is more effective at achieving proper compaction for the required density, and the proper location for the edge of the steel drum is extended over the edge of the first lane by about 6 inches, as shown in [Figure 12](#). By placing the roller at this location, there will be no transverse movement of the mix.



**Figure 12. Proper Location of the Steel Wheel Roller over the Unsupported Edge of the First Paved Lane (Scherozman 2004).**

He also states that placing the roller either inside of or directly over the edge of the unsupported edge will result in transverse movement of the mix, and a crack typically forms at the edge of the drum, as is shown in Figure 13. The amount of movement will depend on the properties of the asphalt. Also, the transverse movement of the mix creates a dip, which makes matching the joint with the second lane difficult.



**Figure 13. Crack Development in the Mix at the Unsupported Edge of Pavement (Scherozman 2004).**

The second critical factor in successfully constructing a longitudinal joint, according to Scherozman, is overlapping the mix of the second lane over the top of the first. If an excessive amount of mix is placed over the edge of the first lane, it will have to be removed by raking the joint. If too little mix is placed over the edge of the first lane, then a depression will occur on the lane 2 side of the joint. The amount of overlap needed is about 1 to 1-½ inches for proper joint construction. Also, since a dense-graded asphalt concrete mix compacts at a rate of ¼ inch per foot, to achieve a compacted thickness of 1 inch the mix must be placed from the back of the paver screed at an uncompacted thickness of about 1-¼ inches. An example of the proper amount of lane overlap is shown in Figure 14, for which no mix will have to be raked off of lane 1.



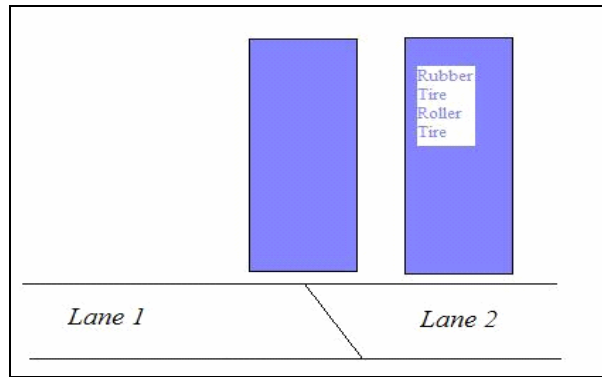
**Figure 14. Proper Amount of Overlap from Lane 2 to Lane 1 (Scherozman 2004).**

Consequently, the third key to proper joint construction is not to have to rake the joint during construction. When raking the joint, the amount of mix that is needed at the joint is usually pushed into the hot mix on lane 2 by setting the rake down on the compacted mix of lane 1 and shoving the mix on top of the hot mix on lane 2. This procedure will result in a low density on the lane 2 side of the joint. Improper raking of the longitudinal joint is shown in Figure 15.

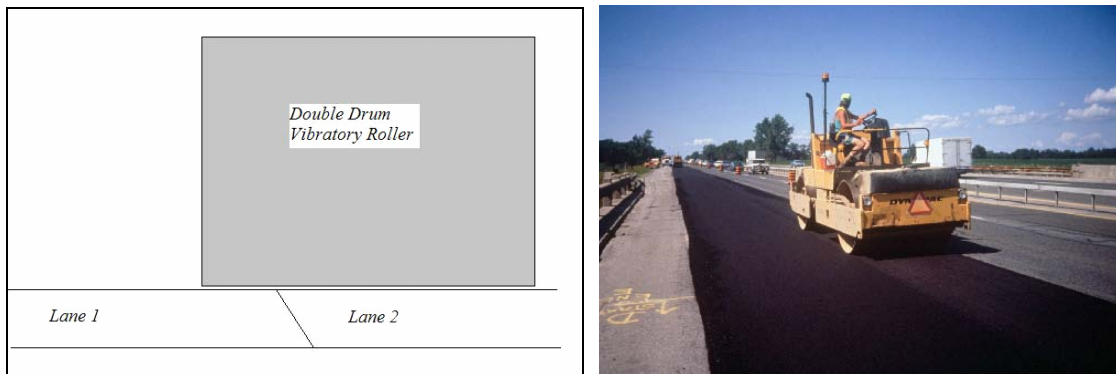


**Figure 15. Improper Raking of the Longitudinal Joint (Scherozman 2004).**

The final key to successful longitudinal joint construction is compaction of the joint, which is dependent upon the location of the rollers. In the past, it was often common practice to compact the longitudinal joint from the cold side of the joint, which proved to be very inefficient. Since most of the drum was located on lane 1 with only 6 to 13 inches of the width of the drum extending over the joint onto lane 2, most of the weight of the roller was on the previously compacted section. While the roller is moving over the cold mix, the temperature of the new hot mix is decreasing, which reduces the opportunity to obtain the desired density. A better location for a pneumatic tire or steel wheel roller would be on the hot side with the roller extended over the top of the joint a short distance. For a pneumatic tire roller, the center of the outside tire should be placed directly over the top of the joint, as shown in Figure 16. Figure 17 shows the proper placement for a steel wheel roller; the majority of the weight of the drum should be placed on the lane 2 side with only about 6 inches extended over the first lane.



**Figure 16. Proper Placement of Pneumatic Tire Roller on the Hot Side (Scherozman 2004).**

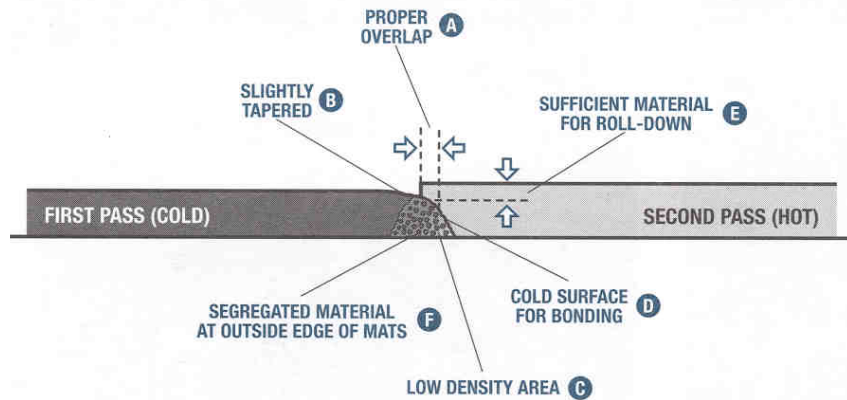


**Figure 17. Proper Placement of Steel Wheel Roller on the Hot Side (Scherozman 2004).**

*NAPA (2002)*

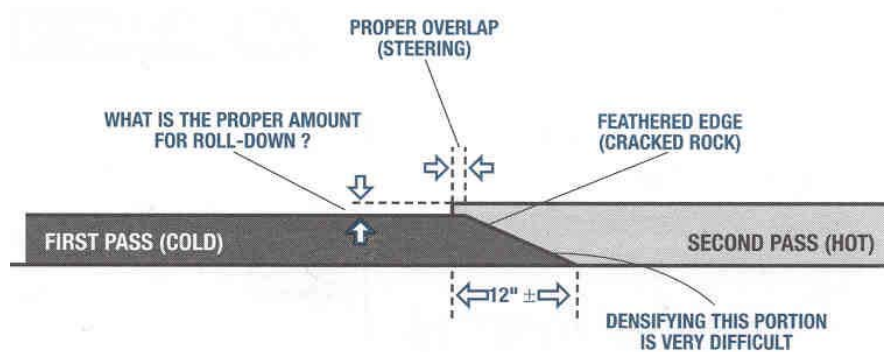
The National Asphalt Pavement Association publication on the problems and solutions to longitudinal joint construction discusses various joint construction challenges and techniques. Some of these challenges include the following and are illustrated in [Figure 18](#):

- developing the proper overlap for the second pass;
- creating the proper taper for the first pass;
- reducing or eliminating a low-density, partially compacted area;
- achieving proper bond between the first and second passes;
- placing sufficient material to allow for roll down to match final grade between the two passes; and
- reducing or eliminating mix segregation at the outside edge of each pass



**Figure 18. Challenge in Longitudinal Joint Construction (NAPA 2002).**

A study on longitudinal joints conducted by the National Center for Asphalt Technology (NCAT) in the early 1990s found that there was an area of low density and high air voids from the center of the joint over 6 to 8 inches. This area allowed water to enter the areas of low density, and freezing would break out the asphalt and lead to premature failure. As a result, the tapered joint technique shown in Figure 19 was developed.



**Figure 19. Tapered Joint Technique (NAPA 2002).**

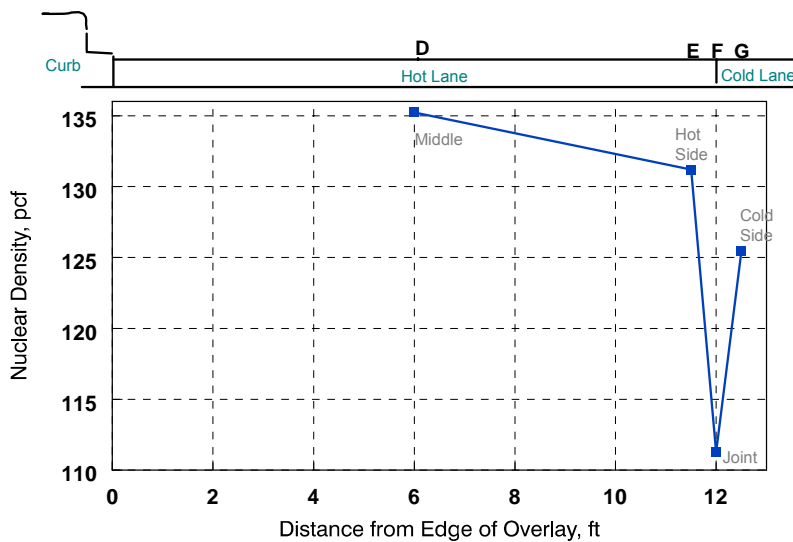
*Estakhri, et al. (2001)*

At the time of Estakhri's research, TxDOT had no specification regarding compaction in the vicinity of the longitudinal construction joints. It was, therefore, presumed that there was poor compaction along the longitudinal joint, which resulted in decreased density, increased permeability, and diminished pavement performance. The objectives of Estakhri's research project were: to assess the density along the longitudinal construction joint of several Texas pavements to determine if a problem exists; to document information from the literature, other agencies, and contractors regarding joint density issues of performance and cost; to synthesize aviation construction data where a history of a joint density specification exists to determine if such a requirement can be met by paving contractors; and to modify current hot mix asphalt concrete (HMAC) specifications to require joint density measurements if justified.

Researchers evaluated 35 pavements as part of this study, of which the three most representative mixture types for the state of Texas were covered. These included: Type C, Type D, and coarse matrix high binder (CHMB). Other pavement types were tested as well. Nuclear density

measurements were taken during construction, after the final roller pass, and while traffic was controlled for construction. These measurements were taken transversely across the paved lane at the joint, 6 inches from the joint, 12 inches from the joint, 24 inches from the joint, and in the middle of the lane. Case studies in Texas were also documented, in which joint density adversely affected pavement performance. Additionally, the TxDOT Aviation Division provided construction data for airfield pavements, which were constructed according to Federal Aviation Administration (FAA) specification item P-401, in which specifications for longitudinal joint construction are made.

The researchers consistently found that there was an area of low density at the edge of the first paved lane. This area is demonstrated in Figure 20, which was the mean density profile for one the sections tested on Loop 323 in Tyler, Texas.



**Figure 20. Mean Density Profile for Loop 323 in Tyler, Texas (Estakhri, et al. 2001).**

Testing on cores taken near the unconfined edge of the pavements being tested also indicated that permeability was higher than those taken from the middle of the lane in the Type C and Type D mixes. The case studies indicated that pavement failures were due to inadequate density at the longitudinal joints, which allowed water intrusion into the pavement structure.

During this research project, TxDOT developed a special provision to Special Specification Item 3146, Quality Control/Quality Assurance of Hot Mix Asphalt. The criterion of this specification, which is shown below, was supported by the research conducted in this study.

**Article 3146.7 Construction Methods is supplemented by the following:**

- (9) Longitudinal Joint Density: The Contractor shall perform a joint density verification for each subplot at the random sample locations selected for in-place air void testing. At each location the Contractor shall perform a nuclear density gauge reading within two foot of a mat edge that will become a longitudinal joint. This reading will be compared to a nuclear density gauge reading taken on the interior of the mat more than two feet from

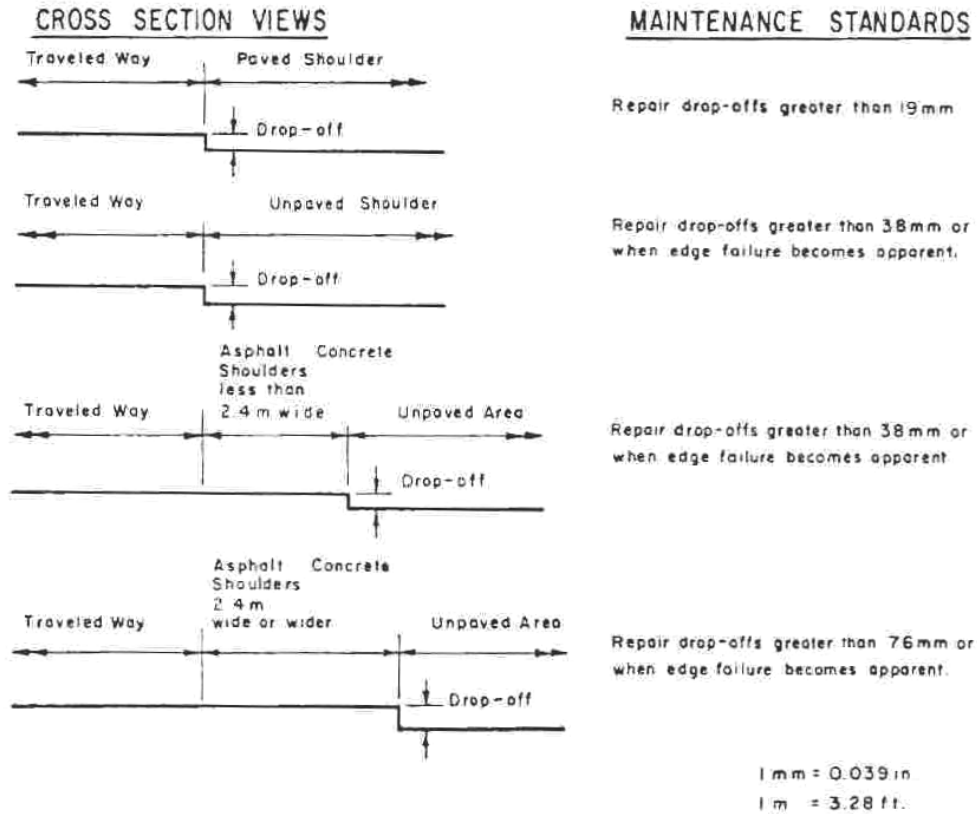
the mat edge. When the density within two foot of the mat edge is more than 5.0 lbs./c.f. below the interior mat density, the verification fails and the contractor shall investigate the cause and take corrective actions during production to improve the joint density. Production of the hot mix asphalt shall cease when two consecutive verifications fail unless otherwise approved by the Engineer. The Contractor shall make changes to the hot mix or the placement process before production is resumed. The Contractor may produce enough mixture to place approximately 2,000 linear feet of pavement one paver width wide. Two joint density verifications shall be performed within these 2,000 linear feet of production and if both verifications are acceptable, the Contractor may resume normal operations. However, if one or both of the joint density verifications fail, the Contractor shall make additional changes as approved by the Engineer and an additional 2,000 linear feet of pavement shall be laid and evaluated as before. This procedure of placing and evaluating 2,000 linear feet sections will be continued until both joint density evaluations pass.

The Engineer may require the Contractor to provide special joint making equipment or implement different joint construction methods to improve joint density. Normal production and joint density verification will resume when both joint density verifications pass. Although it is the Contractor's responsibility to perform joint density verifications, the Engineer may make as many independent joint density verifications as deemed necessary. The Engineer's results will be used to determine joint density when available.

## **Pavement Edge Drop-Off**

*Stoughton, et al. (1979)*

Stoughton's paper documents a 1974 study conducted by the California Department of Transportation concerning some highway accident cases in which a drop-off at the longitudinal edges of the pavement were cited as a possible cause for the accidents. The project sought to: determine the effects of longitudinal drop-offs along a highway and on the stability of vehicles traveling over the drop-offs at high speed, establish maximum tolerable heights for drop-offs, and verify maintenance standards for drop-offs. [Figure 21](#) illustrates California's drop-off standards from the 1974 maintenance manual.



**Figure 21. California's 1974 Maintenance Standards for Edge Drop-Off (Stoughton, et al. 1979).**

To accomplish this procedure, a test site was set up with drop-off heights of 4.5 inches, 3.5 inches, and 1.5 inches along the edge of an existing 5-foot wide asphalt concrete shoulder. Each of the drop-off heights were maintained for 500 feet. Two control tests, in which there were no drop-offs were also conducted. Four different vehicles were used, which included: small, medium, and large automobiles and a pick-up truck. The side walls of the tires were painted to more clearly view scuff marks.

Several conclusions were drawn as a result of this study. Some of these conclusions include:

- Relatively small steering wheel angles were measured for this test, and the driver for these tests handled the steering wheel with minimal effort.
- Vehicle roll angles did not increase significantly.
- Front wheel alignment was not measurably affected.
- When the vehicles remounted the drop-off edge, the first vehicle wheel to contact the edge mounted each drop-off height without delay.
- During all tests, the drivers steered their vehicles back onto the pavement and back into their original lane without encroaching into adjacent lanes.

Researchers also stated that although edge of pavement drop-offs did not adversely affect vehicle control, no consideration was given to other variables like poor mechanical condition, driver



inexperience, adverse weather conditions, roadway and shoulder geometry, roadside obstructions, or hazards. Therefore, these tests results alone were insufficient to establish a maximum tolerable drop-off height for all conditions.

*Lawson and Hossain (2004)*

Lawson’s and Hossain’s report identifies the best practices for pavement edge maintenance. In their report, the importance of work zone safety is also addressed. Noting that unprotected edge drop-offs during construction may occur and that it may not always be practical to eliminate this situation, some measures were offered to ensure safety. First, temporary wedges using the appropriate materials should be used, so that vehicles can traverse the drop-off safely. A hot or cold asphalt mix is suggested when the wedge height is 6-inches or less, and a granular base is suggested when the wedge height is greater than 6-inches. Additional safety recommendations are provided in [Table 5](#).

**Table 5. Traffic Control Needs in Construction Zones for Edge Drop-Off Conditions (Lawson and Hossain 2004).**

Edge Drop Height (inch)	Lateral Position of Edge Drop					
	In Wheel Track	In Lane	On Lane Line	At Edge of Pavement	At Edge of Shoulder	Outside of Shoulder up to 30 ft.
1 to 1-1/4	Uneven Pavement Sign	Uneven Pavement Sign	Uneven Pavement Sign	Low Shoulder Signs	Do Nothing	Do Nothing
1-3/8 to 2	Disallowed	Disallowed	Channelizing Devices with Steady-Burn Lights	Channelizing Devices with Steady-Burn Lights	Channelizing Devices with Steady-Burn Lights	Do Nothing
2-1/8 to 5-7/8	Disallowed	Disallowed	Channelizing Devices with Steady-Burn Lights	Channelizing Devices with Steady-Burn Lights	Channelizing Devices with Steady-Burn Lights	Channelizing Devices
5 or more	Disallowed	Disallowed	Disallowed	Positive Barrier	Positive Barrier	Channelizing Devices with Steady-Burn Lights

### Construction Equipment

It is a common complaint that it is difficult to obtain density requirements when constructing narrow sections. This situation is most often attributed to a lack of the proper equipment with the rollers being either too wide for the section, or too light to properly compact the typical lift thicknesses. This section offers a brief review of available equipment with corresponding specifications.

The Hamm® Model 2220 D vibratory soil compactor features a 54-inch smooth drum, with a 5-ton operating weight and 62 hp engine. This soil compactor is shown in [Figure 22](#), and its specifications are shown in [Table 6](#).



Figure 22. Hamm® Model 2220 D (<http://www.hammcompactors.com>).

Table 6. Hamm® Model 2220 D Specifications (<http://www.hammcompactors.com>).

<b>Operating Weight:</b>	<b>10,700 lbs.</b>
<b>Centrifugal Force:</b>	<b>18,120 lbs.</b>
<b>Working Width:</b>	<b>54 inches</b>
<b>Engine:</b>	<b>Deutz Type F3L 912</b>
<b>Rated Power:</b>	<b>62 hp</b>
<b>Speed:</b>	<b>0-5.6 mph</b>

The Hamm® Model 2222 DS padfoot vibratory soil compactor features a 54-inch padfoot drum, with a 5-ton operating weight and 62 hp engine. This soil compactor is shown in [Figure 23](#), and its specifications are shown in [Table 7](#).



Figure 23. Hamm® Model 2222 DS (<http://www.hammcompactors.com>).

**Table 7. Hamm® Model 2222 DS Specifications (<http://www.hammcompactors.com>).**

<b>Operating Weight:</b>	<b>11,250 lbs.</b>
<b>Centrifugal Force:</b>	<b>18,120 lbs.</b>
<b>Working Width:</b>	<b>54 inches</b>
<b>Engine:</b>	<b>Deutz Type F3L 912</b>
<b>Rated Power:</b>	<b>62 hp</b>
<b>Speed:</b>	<b>0-6.5 mph</b>

The Dynapac CC-122 Tandem Roller is designed for patching and repairs but is also ideal for town work on small streets, pavements, driveways, cycle paths, parking lots, etc. This soil compactor is shown in [Figure 24](#), and its specifications are shown in [Table 8](#).



**Figure 24. Dynapac CC-122 Tandem Roller (<http://www.constructioncomplete.com>).**

**Table 8. Dynapac CC-122 Tandem Roller Specifications (<http://www.constructioncomplete.com>).**

<b>Operating Weight:</b>	<b>N/A</b>
<b>Centrifugal Force:</b>	<b>8170 lbs.</b>
<b>Working Width:</b>	<b>47 inches</b>
<b>Engine:</b>	<b>Deutz Diesel</b>
<b>Rated Power:</b>	<b>30 hp</b>
<b>Production Rate:</b>	<b>120 tons/hr</b>

The compact size of the Caterpillar CP-323C is designed specifically for utility construction with narrow working widths like trench compaction or job sites with limited space. It features a 54-inch working width. This soil compactor is shown in [Figure 25](#).



Figure 25. Caterpillar CP-323C (<http://www.cat.com.cda>).

### Embankment Widening

*Deschamps, et al. (1999)*

The objective of Deschamps' study was to determine the cause of failure in recently widened and/or steepened embankments, and to develop design guidelines for the Indiana Department of Transportation. To accomplish this objective, Deschamps conducted a survey of state and federal transportation agencies and evaluated six sites in which embankment widening occurred. Deschamps, et al. made several recommendations for the successful construction of embankment widening. These recommendations included:

- Remove existing vegetation and organic top soil to obtain an adequate construction joint between the old and new fill and to eliminate the potential for weak seams to develop because of decomposition.
- Constructing benches in existing slopes to provide a good construction joint between old and new fill and to provide a horizontal surface upon which adequate compaction of the lifts can be achieved. One recommendation is that a 3 meter bench be provided on all slopes steeper than 4V:1H.
- Compact fills to a minimum dry density equal to or greater than 95 percent of the maximum dry density achieved in the standard Proctor tests with the water content of the fill being -2 percent to +1 percent of the optimum moisture obtained in the Proctor test.
- When the width of the embankment widening is less than the width of conventional compaction equipment, it may be necessary to compact lifts wide enough to accommodate the equipment.
- Consideration needs to be given to the permeability of the existing embankment material and the material to be used in the widening. If the permeability of the new material is greater than the existing, then water can infiltrate, which could lead to a reduction in shear strength of the material. Also, if the permeability is less than that of the existing material, then water may become trapped within the embankment.

## **CHAPTER THREE**

### **TXDOT DISTRICT SURVEY**

#### **SUMMARY**

A large part of this study was to survey TxDOT pavement engineers and maintenance personnel in order to catalog the various strategies for widening flexible pavements. The survey primarily focused on strategies used when widening under different circumstances, such as: widening a flexible pavement in good condition, widening a flexible pavement in poor condition, and widening a jointed concrete pavement. This survey is included in the [Appendix](#). More specifically, this survey sought to identify strategies regarding:

- structural evaluation;
- pavement coring and field testing;
- typical sections used; and
- inspection methods and quality control.

Additionally, typical construction drawings for each of the previously mentioned circumstances were obtained when available.

Stacy Hilbrich, P.E., surveyed various TxDOT pavement engineers and maintenance personnel, either on the phone or in person. Survey participants included:

- David Gieber, P.E. (San Antonio);
- Darlene Goehl, P.E. (Bryan);
- Andrew Wimsatt, P.E. (Fort Worth),
- Stacey Young, P.E. (Lubbock);
- Joe Leidy, P.E. (Construction Division);
- Mark McDaniel, P.E. (Construction Division);
- Ricky Boles, P.E. (Lufkin);
- Darryl Dincans, P.E. (Lufkin);
- Bradley Martin, P.E. (Paris);
- Mykol Woodruff, P.E. (Paris);
- Phil Murphy, Maintenance Supervisor (Waco);
- Allan Donaldson, Maintenance Supervisor (Fort Worth); and
- Parker Stewart, Maintenance Supervisor (Amarillo).

## DISCUSSION OF SURVEY RESULTS

This section provides a discussion of the survey results regarding pavement widening for each circumstance listed above. Participants were asked several questions concerning the structural evaluation and testing of the existing pavement as well as the construction techniques, specifications, and quality control of the actual widening construction. These results will be discussed for each of these pavement types and conditions:

- flexible pavement in good condition;
- flexible pavement in poor condition; and
- jointed concrete pavement.

### Flexible Pavement in Good Condition

A flexible pavement in good condition is one on which there are no structural failures, and there is no need for rehabilitation. Typically, the pavement widening will be accomplished through the construction of 1– 4 foot shoulders. An example of a flexible pavement in good condition is shown in [Figure 26](#).



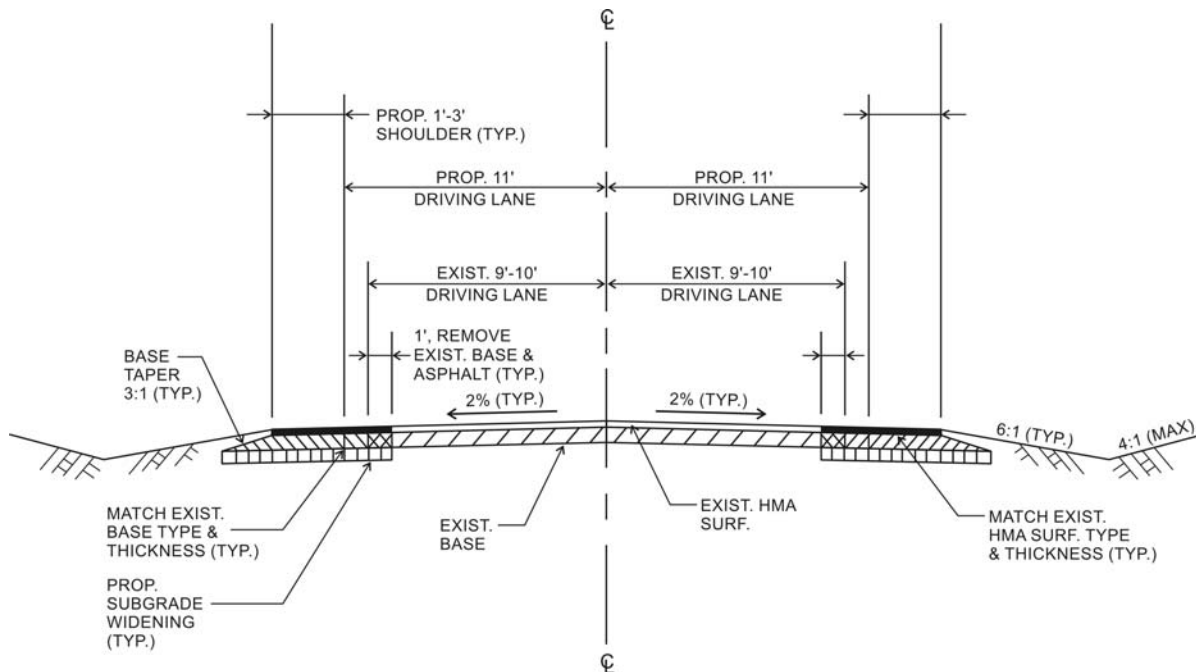
**Figure 26. Flexible Pavement Section in Good Condition.**

When asked whether a structural evaluation would be conducted for this pavement section, responses varied. Although a structural evaluation was strongly recommended, it was found that often a “windshield” survey of the pavement section was conducted, with little or no laboratory investigation being done. The experience of the district is relied upon quite heavily for design decisions in these cases.

In the districts where a structural evaluation is conducted, there are several investigatory methods that are employed. This evaluation typically includes the use of the falling weight deflectometer every 1/10 mile to obtain in-place moduli values, a ground penetrating radar (GPR) survey to verify layer thickness, and obtaining pavement cores every 1 mile down to 7 feet to validate layer thickness and material properties, if matching sections.

When asked about the construction techniques, specifications, and quality control measures employed for the widening construction, most responded that the specification requirements for payment of the particular item is what was followed. However, in certain cases where it was difficult to achieve density on the narrow sections because of the lack of proper equipment, then a change from density control to ordinary compaction under TxDOT Specification Item 132 may be employed. Also, it was suggested that a requirement be made that the density of the hot mix on the shoulders be the same as the main lanes; however, there is no current spec item for this. It was also stated that placing the joint in the wheel path is the most commonly encountered problem in constructing these widened sections.

Several Districts provided typical construction drawings for this particular widening construction. These were incorporated into the flexible pavement widening guideline, which is provided in TxDOT Product 0-5429-P2 (Hilbrich and Scullion), and an example of this is also shown in [Figure 27](#).



**Figure 27. Typical Section for Widening Flexible Pavements in Good Condition.**

### **Flexible Pavement in Poor Condition**

A flexible pavement in poor condition will have severe rutting, may require heavy maintenance, and will be a candidate for reconstruction/rehabilitation. An example of a flexible pavement in poor condition is shown in [Figure 28](#).



**Figure 28. Flexible Pavement Section in Poor Condition.**

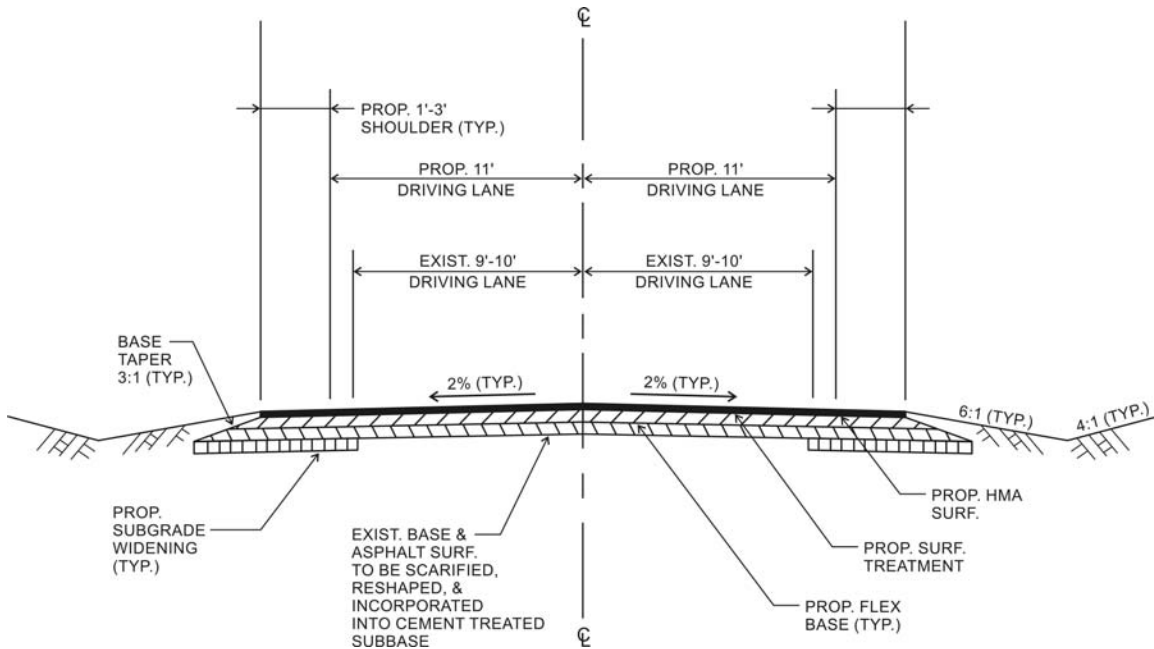
When asked whether a structural evaluation would be conducted for this pavement section, responses also varied. However, the testing and evaluation previously discussed for the flexible pavement in good condition was also followed.

In the districts where a structural evaluation is conducted, there are several investigatory methods that are employed. This typically includes the use of the FWD every 1/10 mile to obtain in-place moduli values, a GPR survey to verify layer thickness, and obtaining pavement cores every 1 mile down to 7 feet in order to validate layer thickness.

Full depth recycling was found to be a first choice alternative when the existing pavement was in poor condition. For this particular method, TxDOT specification items 112 and 132 are followed for widening and compacting the subgrade, respectively. TxDOT Specification Item 251 is followed for reworking the existing hot mix asphalt (HMA) surface into the existing base. It was also noted that the amount of existing HMA surface to be reworked into the existing base should be kept below 50 percent. Also, care must be taken to avoid contaminating the reworked base with the subgrade soil.

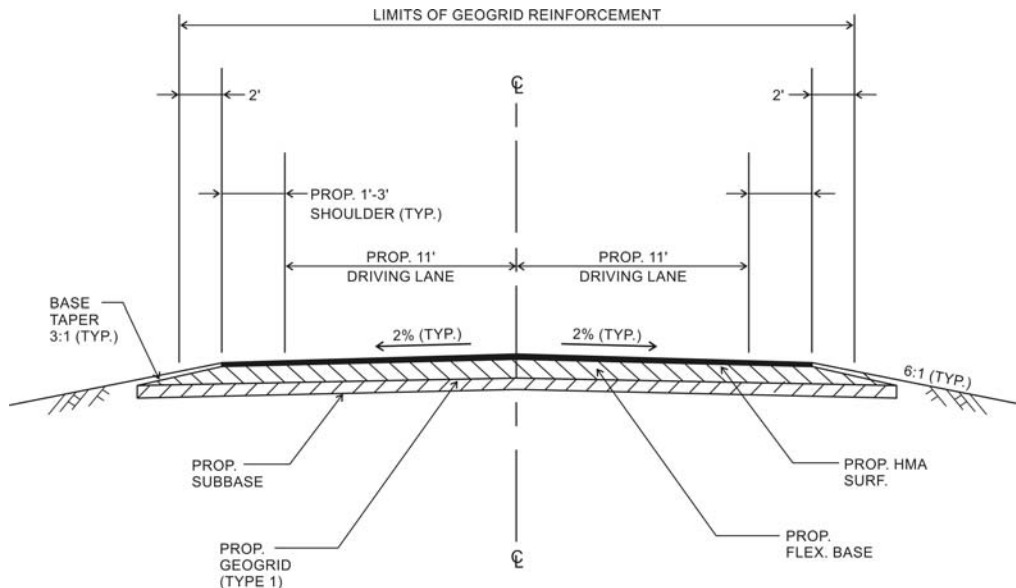
Several Districts provided typical construction drawings for these this particular widening construction. These drawings were incorporated into the flexible pavement widening guideline, which is provided in TxDOT Product 0-5429-P2 (Hilbrich and Scullion), and an example of this is also shown in [Figure 29](#).





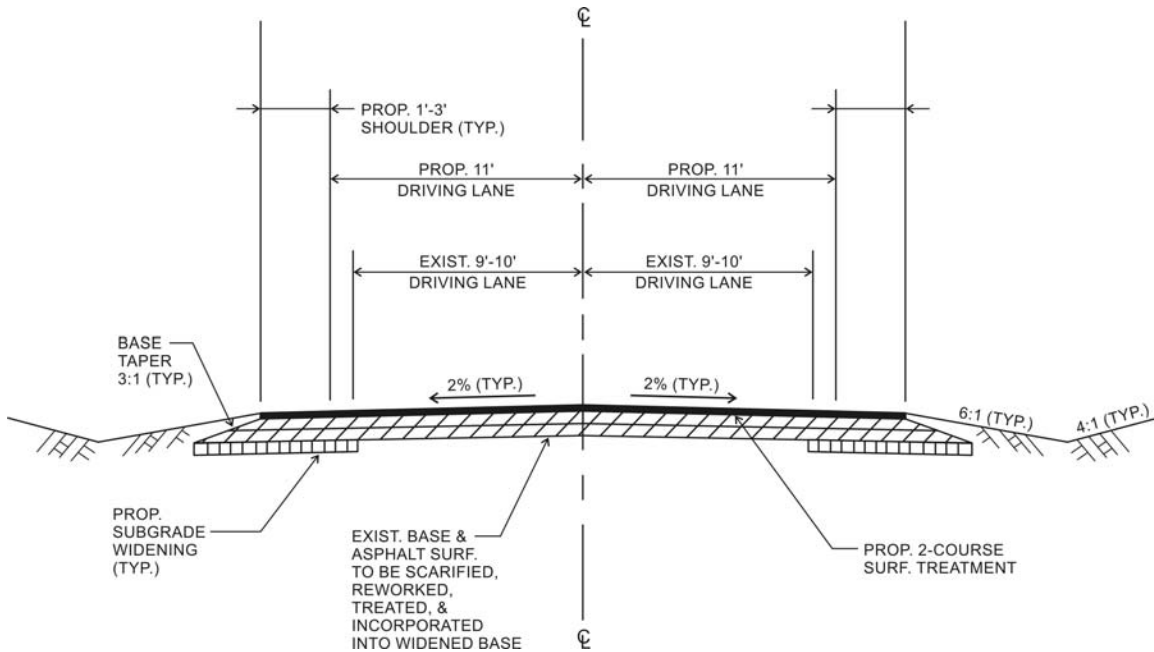
**Figure 29. Typical Section for Widening Flexible Pavements in Poor Condition Using Full Depth Recycling.**

A viable alternative when the flexible pavement to be widened is on top of a highly expansive subgrade, PI > 35 was found based on the experience of the Bryan District. Use of the Tensar Grid is very effective at intercepting reflection cracks from the lower layers and, thus, minimizing the longitudinal cracks that are often a result of edge drying. The Bryan District now routinely uses this procedure on its widening projects. [Figure 30](#) shows a typical construction drawing incorporating the use of geogrid.



**Figure 30. Typical Section for Widening Flexible Pavements in Poor Condition on Highly Plastic Subgrades.**

Another cost-effective alternative for widening low volume roads when there are less than 1000 vehicles per day (vpd) and the existing pavement is in poor condition is to rework and treat the existing base before widening to the desired width. A two-course surface treatment would then be applied. Care must be taken to avoid contamination of the reworked base with the subgrade soil. Since the existing material thicknesses can vary, it is highly recommended that a GPR survey or coring of the pavement to be reworked be conducted to verify layer thicknesses. Also, this testing will verify whether there is sufficient existing base thickness to construct with this method. Figure 31 provides a typical construction drawing for this method.



**Figure 31. Typical Section for Widening Flexible Pavements in Poor Condition by Reworking the Existing Base.**

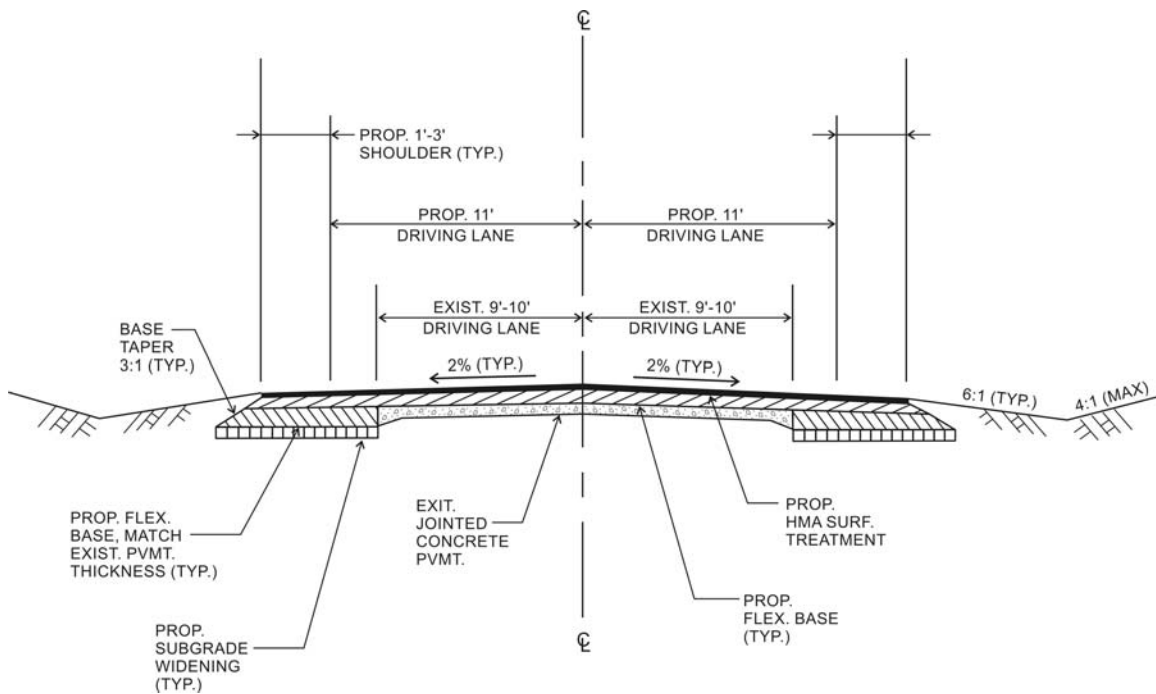
## JOINTED CONCRETE PAVEMENT

A jointed concrete pavement may or may not have any structural failures and will be a candidate for widening. An example of a jointed concrete pavement (JCP) is shown in Figure 32.



**Figure 32. Jointed Concrete Pavement.**

Researchers found that when widening JCP, it is not critical to match sections. Matching sections is critical when the existing base material is moisture susceptible, such as flexible base. Widening JCPs is often performed with full depth hot mix or cement-treated base. However, widening with flexible base material is not recommended. As was previously mentioned under “Flexible Pavement in Good Condition,” there is usually little laboratory investigation or pavement design involved. As is the case with a flexible pavement in good condition, it is extremely important to get a good density in the subgrade widening, as not doing so will adversely affect the densities in the subsequent layers. Once again, it is critical to confirm with the contractor prior to construction that there is equipment available that can adequately compact these narrow sections. This construction detail is provided in [Figure 33](#).



**Figure 33. Typical Section for Widening Jointed Concrete Pavements.**



## CHAPTER FOUR

### CONCLUSIONS

The purpose of TxDOT Project 5429, “Considerations for Flexible Pavement Widening Projects,” was to address design considerations in selecting the appropriate technique when widening an existing pavement. The major pavement-related issues with widening are as follows:

- Widening can be fairly narrow, say 2 to 4 feet on either side of an existing highway. It is often difficult to get normal compaction equipment to compact this narrow of a strip. Guidelines are required on what equipment is required to adequately complete compaction.
- How can the quality of widened sections be inspected?
- The widened section often becomes the place where trucks outer wheels run; any variations in density/quality will be quickly exposed. The widened area should have equal or better structural strength than the existing pavement.
- The widening often leaves a vertical construction face between the old and new structure, which trucks run directly over.
- Some districts have experienced problems with widening sections with different base materials. This method can cause a situation where moisture can be trapped in the original structure. Some districts have adopted a “matching cross-section” philosophy; others have not.
- Where and when should stabilization of the existing subgrade be performed? Which stabilizer and what percentage should be used?
- When full-depth reclamation of the existing roadway is used as the first step in the widening process, some districts have reported problems with severe longitudinal cracking. These problems have been studied, and some districts have adopted practices to minimize these problems.

Several other design and safety issues exist, such as: tying into existing structures and widening steep side slopes.

A large portion of this project involved an extensive literature review, in which researchers obtained information regarding the various design and construction issues in pavement widening. This chapter provides a detailed summary of the literature review. The review is organized according to the following key areas:

- Stabilization,
- Pavement Edgedrains and Subsurface Drainage,
- Longitudinal Construction Joints,
- Pavement Edge Drop-Offs,
- Construction Equipment, and
- Embankment Widening.

A survey of TxDOT pavement engineers and maintenance personnel was also conducted to catalog the various strategies for widening flexible pavements. The survey primarily focused on strategies used when widening under different circumstances, such as: widening a flexible pavement in good condition, widening a flexible pavement in poor condition, and widening a jointed concrete pavement; and typical construction drawing were obtained for each case. This survey is included in the Appendix. More specifically, this survey sought to identify strategies regarding:

- structural evaluation;
- pavement coring and field testing;
- typical sections used; and
- inspection methods and quality control.

This study concluded with a site-specific approach to selection of proper material use and/or re-use, construction technique, and traffic control to warrant rapid construction and long term stability of the widened pavement. These findings are summarized into a flexible pavement widening guideline, which is provided in TxDOT Product 0-5429-P2 (Hilbrich and Scullion).

## REFERENCES

- Baumgardner, Robert. *Maintenance of Highway Edge Drains*. <http://www.fhwa.dot.gov/pavement/concrete/edge.cfm>, Feb. 2002.
- Birgisson, B. and R. Roberson. *Drainage of Pavement Base Material: Design and Construction Issues*. Transportation Research Record 1709, Transportation Research Board, Washington, D.C., 2000, pp. 11-18.
- Bredenkamp, S., T. Scullion, J. Ragsdale, and S. Sebesta. *Evaluation of Vertical Moisture Barriers Installed on IH 45 near Palmer, Texas*, Report 3930-1, Texas Transportation Institute, College Station, TX, 1999.
- Deschamps, R., C. Hynes, and P. Bourdeau. *Embankment Widening Design Guidelines and Construction Procedures*, Report FHWA/IN/JTRP-99/4, Joint Transportation Research Program, West Lafayette, IN, 1999.
- Estakhri, Cindy, T. Freeman, and C. Spiegelman. *Density Evaluation of the Longitudinal Construction Joint of Hot-Mix Asphalt Pavements*, Report 1757-1, Texas Transportation Institute, College Station, TX, 2001.
- Fleckenstein, L. John and David Allen. *Evaluation of Pavement Edge Drains and Their Effect on Pavement Performance*. Transportation Research Record 1519, Transportation Research Board, Washington, D.C., 1996, pp. 28-35.
- Foster, C.R. *Constructing Longitudinal Joints in Hot-Mix Asphalt Pavements*. Transportation Research Record 51, Transportation Research Board, Washington, D.C., 1964, pp. 124-136.
- Guthrie, W. Spencer, S. Sebesta, and T. Scullion. *Selecting Optimum Cement Contents for Stabilizing Aggregate Base Materials*, Report 7-4920-2, Texas Transportation Institute, College Station, TX, 2002.
- Hagen, Mark and George Cochran. *Comparison of Pavement Drainage Systems*. Transportation Research Record 1519, Transportation Research Board, Washington, D.C., 1996, pp. 1-18.
- Harris, P., T. Scullion, and S. Sebesta. *Hydrated Lime Stabilization of Sulfate-Bearing Soils in Texas*, Report 4240-2, Texas Transportation Institute, College Station, TX, 2004.
- Hilbrich, S. and T. Scullion. *Guidelines for Design of Flexible Pavement Widening*, 0-5429-P2, Texas Transportation Institute, College Station, TX, 2006.
- Little, D. N., *Handbook for Stabilization of Pavement Subgrades and Base Courses with Lime*, Kendall/Hunt Publishing Company, Iowa, 1995a.

Little, Dallas, T. Scullion, P. Kota, and J. Bhuiyan. *Identification of the Structural Benefits of Base and Subgrade Stabilization*, Report 1287-2, Texas Transportation Institute, College Station, TX, 1995b.

National Asphalt Pavement Association (NAPA). *Longitudinal Joints: Problems and Solutions*, Quality Improvement Series 121, Lanham, MD, Sept. 2002.

NCHRP. *Performance of Pavement Subsurface Drainage*, Research Results Digest Number 268, Transportation Research Board, Washington, D.C., Nov. 2002.

Ransinghege, J. et al. *Effectiveness of Controlling Pavement Roughness due to Expansive Clays with Vertical Moisture Barriers*, Report 1165-2F, Texas Transportation Institute, College Station, TX, 1992.

Scherocman, James. *Construction of Durable Longitudinal Joints*, Cincinnati, OH, Dec. 2004.

Scullion, Tom, S. Sebesta, J. Harris, and I. Syed. *A Balanced Approach to Selecting the Optimal Cement Content for Soil-Cement Bases*, Report 404611-1, Texas Transportation Institute, College Station, TX, 2000a.

Scullion, Tom, S. Sebesta, and J. Harris. *Stabilizing Plastic Clay Soils with Cement: A Laboratory Investigation*, Report 404611-2, Texas Transportation Institute, College Station, TX, 2000b.

Stoughton, Roger, D. Parks, J. Stoker, and E. Nordin. *Effect of Longitudinal Edge of Paved Surface Drop-offs on Vehicle Stability*. Transportation Research Record 703, Transportation Research Board, Washington, D.C., 1979, pp. 24-30.

Texas Department of Transportation (TxDOT). *Guidelines for Modification and Stabilization of Soils and Base for Use in Pavement Structures*. Austin, TX, September 2005a. Accessed online at <ftp://ftp.dot.state.tx.us/pub/txdot-info/cmd/tech/stabilization.pdf>.

Texas Department of Transportation (TxDOT). *Roadway Design Manual*. Austin, TX, October 2005b. Accessed online at <http://manuals.dot.state.tx.us/dynaweb/coldesig/rdw>.

Wells, Gordon and William Nokes. *Performance Evaluation of Retrofit Edge Drain Projects*. Transportation Research Record 1425, Transportation Research Board, Washington, D.C., 1993, pp. 11-17.



**APPENDIX**  
**DISTRICT SURVEY**



*This questionnaire should be completed by someone who is responsible for designing widening projects in your district.*

**Your name:**

**Position:**

**Your e-mail address:**

**Your phone number:**

**District:**

### **Background information**

TxDOT will shortly undertake letting of construction projects for flexible pavement widening on current pavement widths less than 24' with ADTs greater than 400. Typically, these projects will be FM roads of approximately 20 foot widths, where widening will extend the pavement width to approximately 27 to 28 feet. Around the state, different Districts use different typical methods for designing and constructing these widening projects. This survey is being conducted in order to catalog these various methods into what is working and what is not, which will ultimately result in the assembly of design guidelines for these pavement widening projects.

### **Section 1: General Information for Pavement Widening Selection**

- 1) Who is responsible for submitting candidate projects for consideration for widening?
  
- 2) Who is responsible for designing the widened pavement sections?
  
- 3) Does your district have a policy regarding which projects to submit to the different program calls?

**Please continue on to the next section**

## Section 2: Specific Case Studies of Flexible Pavement Widening

### *Case 1: Flexible Pavement Section in Good Condition (See Figure 1) No structural failures*



**Figure 1:** Flexible Pavement Section in Good Condition

- 1) For this particular case, would a structural evaluation be conducted? If so, please describe the evaluation and how the collected data was utilized to make the design.
  
- 2) For this particular case, would any coring or other field testing be performed? If so, please describe the testing procedures and how the collected data was utilized.

- 3) For this particular case, does your district have typical pavement section(s) that would be used? If so, please provide a copy of the typical pavement section(s).
  
- 4) For this particular case, please describe the construction techniques and specifications you used and/or most recommend.
  
- 5) For this particular case, please describe how inspections are performed and what quality control testing is performed.
  
- 6) For the approach described above can you locate the project(s) and allow the research team to perform an evaluation of the widening performance?
  
- 7) Has the District found any problems with widening sections which were originally in good condition?

***Case 2: Flexible Pavement Section in Poor Condition (See Figure 2) Rutting/heavy maintenance***



**Figure 2:** Flexible Pavement Section in Poor Condition

Skip this section if you have never designed widening for roadways in poor condition

- 8) For this particular case, would a structural evaluation be conducted? If so, please describe the processes involved in the evaluation and how the collected data was utilized to make the design.
  
  
  
  
  
  
  
  
  
  
- 9) For this particular case, would any coring or other field testing be performed? If so, please describe the testing procedures and how the collected data was utilized.



*Case 3: Jointed Concrete Pavement (see Figure 3)*



**Figure 3: Jointed Concrete Pavement**

If you have never dealt with this case please skip section

15) For this particular case, would a structural evaluation be conducted? If so, please describe the processes involved in the evaluation and how the collected data was utilized to make the design.

16) For this particular case, would any coring or other field testing be performed? If so, please describe the testing procedures and how the collected data was utilized.



17) For this particular case, does your district have typical pavement section(s) that would be used? If so, please provide a copy of the typical pavement section(s).

18) For this particular case, please describe the construction techniques and specifications you used and/or most recommend.

19) For this particular case, please describe how inspections are performed and what quality control testing is performed.

20) For the approach described above can you locate the project(s) and allow the research team to perform an evaluation of the widening performance?

21) Has the District found any problems with widening old concrete sections?

Please continue on to the next section

**Section 3: Special Case Studies of Flexible Pavement Widening**

***Special Case 1: Flexible Pavement with Steep Side Slopes (See Figure 4)***



**Figure 4:** Flexible Pavement with Steep Side Slopes

22) How would the designs be changed if the section has very high side slopes?

***Special Case 2: Flexible Pavement Widening at Narrow Bridge (See Figure 5)***



**Figure 5:** *Narrow Bridge Approach*

23) How do you handle narrow bridges?

24) Are there any other geometric considerations which impact the widening design. What are they and how do you handle it?

**Section 4: Other Considerations for Flexible Pavement Widening**

25) Has your district encountered problems with any of the following on pavement widening projects:

a) Placing a joint in the wheel path? If so, how was the problem resolved?

b) Vertical construction faces? If so, how was the problem resolved?

c) Not matching sections? If so, how was the problem resolved?

d) Quality control? If so, how was the problem resolved?

e) Traffic control? If so, how was the problem resolved?

f) Any other construction issues? If so, how was the problem resolved?

## **End of Survey**

Thank you for completing this survey. Please save your completed survey (click on “File” then “Save As” and type in a file name), then e-mail the file to Stacy Hilbrich at the Texas Transportation Institute: [s-hilbrich@ttimail.tamu.edu](mailto:s-hilbrich@ttimail.tamu.edu)

Or mail a hard copy to

Stacy Hilbrich, P.E.  
Texas Transportation Institute  
3135 TAMU  
College Station, TX 77843-3135