

1. Report No. FHWA/TX-09/0-4825-P1		2. Government Accession No.		3. Recipient's Catalog No.	
4. Title and Subtitle CORROSION PERFORMANCE TESTS FOR REINFORCING STEEL IN CONCRETE: TEST PROCEDURES				5. Report Date February 2009 Published: September 2009	
				6. Performing Organization Code	
7. Author(s) David Trejo and Ceki Halmen				8. Performing Organization Report No. Product 0-4825-P1	
9. Performing Organization Name and Address Texas Transportation Institute The Texas A&M University System College Station, Texas 77843-3135				10. Work Unit No. (TRAIS)	
				11. Contract or Grant No. Project 0-4825	
12. Sponsoring Agency Name and Address Texas Department of Transportation Research and Technology Implementation Office P. O. Box 5080 Austin, Texas 78763-5080				13. Type of Report and Period Covered Product September 2003 – August 2008	
				14. Sponsoring Agency Code	
15. Supplementary Notes Research performed in cooperation with the Texas Department of Transportation and the Federal Highway Administration. Project Title: Corrosion Performance Tests for Reinforcing Steel in Concrete URL: <a href="http://ti.tamu.edu/documents/0-4825-P1.pdf">http://ti.tamu.edu/documents/0-4825-P1.pdf</a>					
16. Abstract The existing test method to assess the corrosion performance of reinforcing steel embedded in concrete, mainly ASTM G109, is labor intensive, time consuming, slow to provide comparative results, and often expensive. However, corrosion of reinforcement is a major challenge to the performance and long-term durability of infrastructure systems. Improvements in the corrosion performance of materials could add significant value to the infrastructure. New procedures and test methods are needed to assess the corrosion performance of potentially value-adding materials. This study evaluated four accelerated test procedures: the mini-macrocell (MM) test, the concrete chloride ion assessment (CCIA) test (also referred to as the concrete corrosion inhibitor association test), the accelerated chloride threshold (ACT) test, and the modified G109 test. Results from the accelerated tests were compared with results from the standard ASTM G109 results. The rapid MM test proved to be relatively simple, and researchers recommend that it be used to assess the relative performance of several material systems. The CCIA and ACT tests are recommended only when the critical chloride threshold of a reinforced system is needed. These tests are more complex and expensive to perform than the MM test. This product provides the procedures for performing these tests. The modified G109 test can continue to be used, but test durations are still relatively long.					
17. Key Words Corrosion Test, Accelerated Corrosion Test, Polarization Resistance, Half-Cell Potential, Corrosion Rate, Critical Chloride Threshold			18. Distribution Statement No restrictions. This document is available to the public through NTIS: National Technical Information Service Springfield, Virginia 22161 <a href="http://www.ntis.gov">http://www.ntis.gov</a>		
19. Security Classif.(of this report) Unclassified		20. Security Classif.(of this page) Unclassified		21. No. of Pages 34	22. Price



**CORROSION PERFORMANCE TESTS FOR REINFORCING STEEL  
IN CONCRETE: TEST PROCEDURES**

by

David Trejo, Ph.D., P.E.  
Associate Research Engineer  
Texas Transportation Institute

and

Ceki Halmen  
Assistant Professor  
University of Missouri, Kansas City

Product 0-4825-P1

Project 0-4825

Project Title: Corrosion Performance Tests for Reinforcing Steel in Concrete

Performed in cooperation with the  
Texas Department of Transportation  
and the  
Federal Highway Administration

February 2009

Published: September 2009

TEXAS TRANSPORTATION INSTITUTE  
The Texas A&M University System  
College Station, Texas 77843-3135



## **DISCLAIMER**

The contents of this report reflect the views of the authors, who are responsible for the facts and the accuracy of the data presented herein. The contents do not necessarily reflect the official view or policies of the Federal Highway Administration (FHWA) or the Texas Department of Transportation (TxDOT). References to specific products are for information only and do not imply any claim of performance for that particular product. This report does not constitute a standard, specification, or regulation. The researcher in charge was David Trejo, P.E. #93490.

## **ACKNOWLEDGMENTS**

This project was conducted at Texas A&M University and was supported by the Texas Department of Transportation (TxDOT) and the Federal Highway Administration (FHWA) through the Texas Transportation Institute (TTI) as part of Project 0-4825, “Corrosion Performance Tests for Reinforcing Steel in Concrete.” The valuable input from R. Sarcinella (project director), L. Lukefar (program coordinator), and TxDOT project advisors R. Owens, T.J. Hollen, J. Farris, and C. Russel was appreciated. The authors also wish to thank Erica Sanchez and Stephanie Streid.

# TABLE OF CONTENTS

	<b>Page</b>
List of Figures .....	viii
1. Introduction.....	1
2. Rapid Mini-O acrocell Test .....	3
3. Concrete Chloride Ion Assessment Test.....	11
4. Accelerated Chloride Threshold Test .....0.....	17
5. Summary .....	25
References.....	27

## LIST OF FIGURES

	<b>Page</b>
Figure 1. Mortar-Covered Steel Specimen. ....	4
Figure 2. Bottom Part of the Mold.....	4
Figure 3. Casting Setup for Rapid Macrocell Samples.....	6
Figure 4. Rapid Mini-macrocell Setup.....	7
Figure 5. Rapid Macrocell Test Setup on the Rack. ....	8
Figure 6. Mold for CCIA Sample. ....	12
Figure 7. CCIA Test Sample and Setup.....	13
Figure 8. Mortar Powder Collected from the Top Part.....	15
Figure 9. Steel Specimen of ACT Test (Pillai 2003).....	18
Figure 10. ACT Test Sample (Pillai 2003).....	19
Figure 11. Haber-Lugin Probe and Reference Electrode (Pillai 2003).....	20



## 1. INTRODUCTION

Project 0-4825 investigated the corrosion performance of several different systems containing different reinforcement types, water-cement ratios, and amounts of corrosion inhibitor. The systems were evaluated using a commonly used standard test method, ASTM G109, *Standard Test Method for Determining Effects of Chemical Admixtures on Corrosion of Embedded Steel Reinforcement in Concrete Exposed to Chloride Environments*. This method is commonly used to evaluate the potential improvements from high performance reinforcement, concrete sealers, supplementary cementing materials (SCMs), and the addition of chemical admixtures. It has become the standard for evaluating many corrosion systems. However, when evaluating systems with improved performance, this test can take many years, with some reported test times of over 10 years. This is not an economically viable test procedure for assessing higher performing systems.

This research evaluated four alternative test procedures: the mini-macrocell (MM) test, the concrete chloride ion assessment (CCIA) test (also referred to as the concrete corrosion inhibitor association test), the accelerated chloride threshold (ACT) test, and the modified G109 test. Results found that the MM test should be used to compare the corrosion performance of most systems because it can be completed in a relatively short period and is relatively simple. The CCIA and ACT tests were recommended for use only if the critical chloride threshold is needed, which is often the case when assessing service life. However, these tests are more complex than the MM test, and the CCIA and ACT tests require specialized electrochemical equipment and specific expertise.

This manual provides the procedures for performing the MM, CCIA, and ACT tests. Step-by-step procedures are provided so that these tests can be performed by state highway agencies (SHAs) or engineering test firms.

Report 0-4825-1 recommended that SHAs, specifically the Texas Department of Transportation (TxDOT), not be directly involved in the assessment of new, potentially durable (or corrosion-resistant) products. It was recommended that the manufacturer of the new material or product have an independent testing agency identified by TxDOT assess the product at the

manufacturer's expense. If desired, TxDOT (or another independent testing agency) can perform complementary tests to validate these results. The following sections provide the test procedures.

## 2. RAPID MINI-MACROCELL TEST

The mini-macrocell test evaluates the corrosion of a reinforcing bar embedded in mortar (the anode) exposed to chloride solution. It accelerates the time to corrosion by having a cathodic system (two reinforcing bars embedded in mortar and exposed to water) and minimal mortar cover over the reinforcement. This section provides a description of the procedure to fabricate and test MM samples.

No. 5 (No. 16 metric) reinforcement shall be used to prepare the rapid macrocell samples. Steel reinforcement shall be cut using a liquid-cooled band saw to obtain 5-inch (127 mm) long specimens. One end of the specimen shall be drilled using a drill and a No. 27 drill bit and tapped to receive a 3/8-inch (9.5 mm) long, No. 8-32 stainless steel machine screw. Steel specimens shall then be cleaned in ethyl alcohol using an ultrasonic cleaner. A 0.6-inch (15.24 mm) band, centered 2 inches (50.8 mm) from the top of each steel specimen, shall be coated with a two-part, high viscosity epoxy. This coating is applied to prevent accelerated corrosion of the steel specimens due to galvanic corrosion at the section where they protrude from the mortar. [Figure 1](#) shows the mortar-covered steel specimens.

A plastic mold assembly consisting of two parts (bottom and top) can be used with polyvinyl chloride (PVC) pipes to cast the mortar cover around the steel specimens. The bottom part is a  $13.8 \times 8.75 \times 2$  inch ( $350.5 \times 222.3 \times 50.8$  mm) plastic slab with 15 holes drilled in three rows of five holes. The holes shall have a diameter of 0.7 inches (17.8 mm) and shall be 2 inches (50.8 mm) deep. At the center of the bottom of each hole, there shall be a smaller hole with a diameter of 0.12 inches (3 mm) that protrudes through the rest of the thickness of the slab. [Figure 2](#) shows the bottom part of the mold.

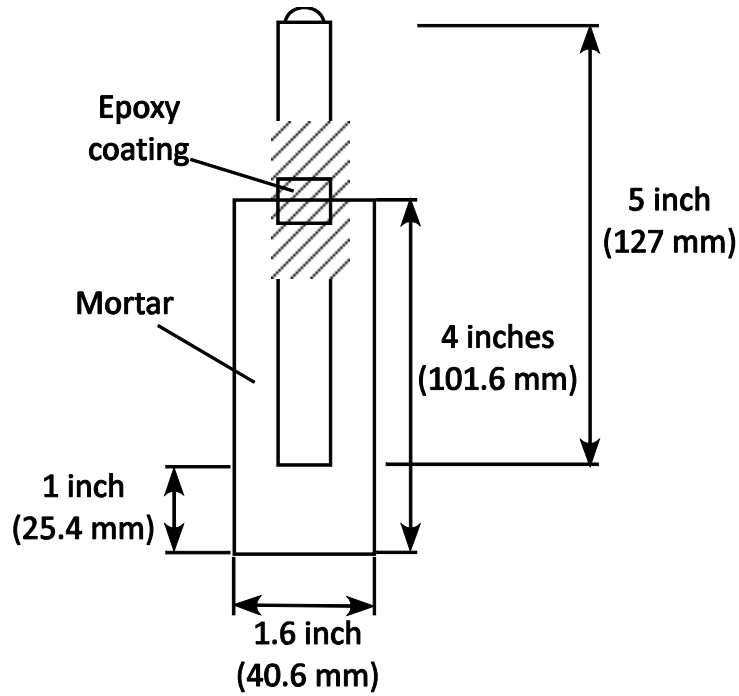

Figure 1. Mortar-Covered Steel Specimen.

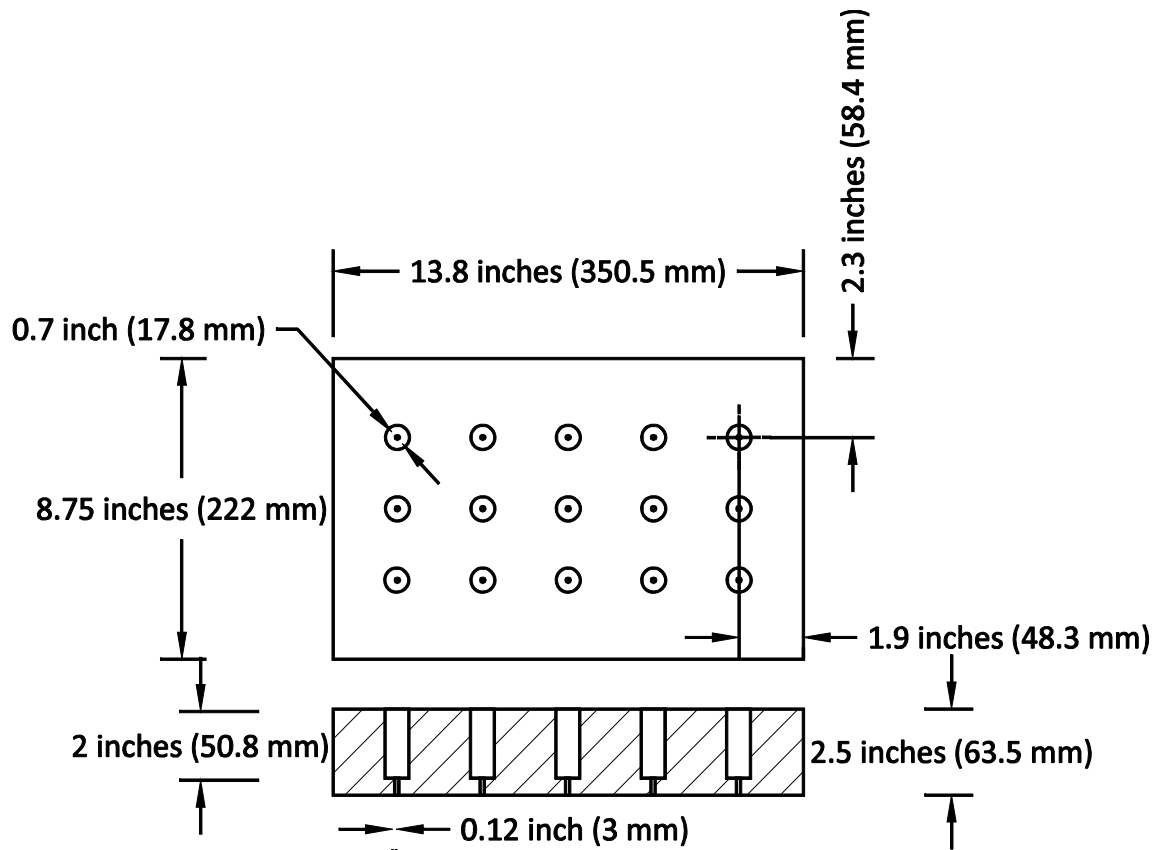
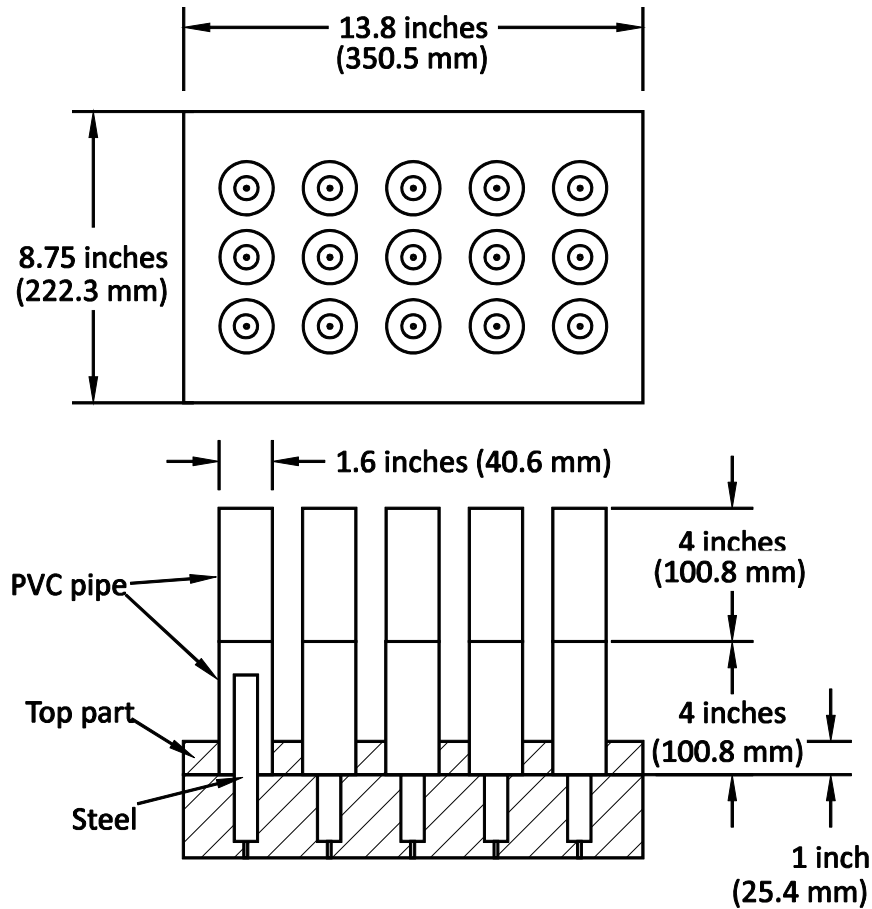

Figure 2. Bottom Part of the Mold.

The top part of the mold shall have the same dimensions as the bottom part, but its thickness shall be 1 inch (25 mm). The top part shall have three rows of five holes with a diameter of 1.6 inches (40.6 mm). The holes in the bottom and top shall align at the center. The two parts shall be fixed together with a set of clamps or screws, and the steel reinforcement shall be inserted into the bottom part of the mold. A PVC pipe with an outside diameter of 1.6 inches (40.6 mm) shall be cut into 4-inch (101.6 mm) pieces. Two 4-inch (101.6 mm) pieces shall be taped together (as shown in [Figure 3](#)). The 8-inch (200-mm) long PVC pipe pieces shall then be inserted into the top part of the mold around the steel specimens for casting samples.

The entire assembly shall be placed on a vibrating table. Mortar shall then be placed into the PVC pipe pieces in three layers and each layer vibrated 3 to 4 seconds at 60 Hz. The top 4-inch (101.6 mm) long PVC pipe is used to overfill the bottom part during the placement of the third layer to make sure that the bottom part is completely filled with consolidated mortar. At the end of casting, the top PVC pipe pieces shall be removed and discarded and the mortar finished flush with the top of the bottom PVC pipe pieces. [Figure 3](#) shows the casting setup for the rapid macrocell corrosion test.

Immediately after the casting of the samples, the sample shall be covered with wet burlap. After the initial set they shall be moved to a curing room at 73°F (23°C) and 98 percent relative humidity (RH). Samples can be removed from the molds 72 hours after casting, but care must be taken not to damage the samples. Samples shall be cured for 28 days.



**Figure 3. Casting Setup for Rapid Macrocell Samples.**

Cylindrical, 6 × 4.5 inch (150 × 114 mm) containers with lids can be used to expose the samples for rapid macrocell testing (Figure 4). Containers can be made of high density polyethylene or another compatible material. Each test setup shall consist of two containers, one for the anode and one for the cathode. One specimen is placed in a container to act as the anode, and two specimens are placed in another container to act as cathodes. Lids, with a hole drilled to hold the No. 5 (No. 16 metric) steel reinforcement, shall be used to prevent moisture loss. Plastic O-rings can be placed between the steel specimens and plastic lids to hold the specimens in the vertical position. Cathode containers are filled with simulated concrete pore solution and mortar pieces. Anode containers are filled with a simulated concrete pore solution with a 1.6 molal ion concentration of sodium chloride and mortar fill. Two extra holes are drilled into the lid of the anode containers for insertion at a saturated calomel electrode and the salt bridge. Two additional holes shall be drilled into the lid of the cathode containers. The holes in the lid

of the cathode containers are used to insert the vinyl tubing that supplies the cathode with scrubbed air and the salt bridge. Scrubbed air shall be supplied to the cathode to support the reduction reactions that require oxygen. Salt bridges provide the ionic path between the anode and cathode containers to complete the electrical circuit.

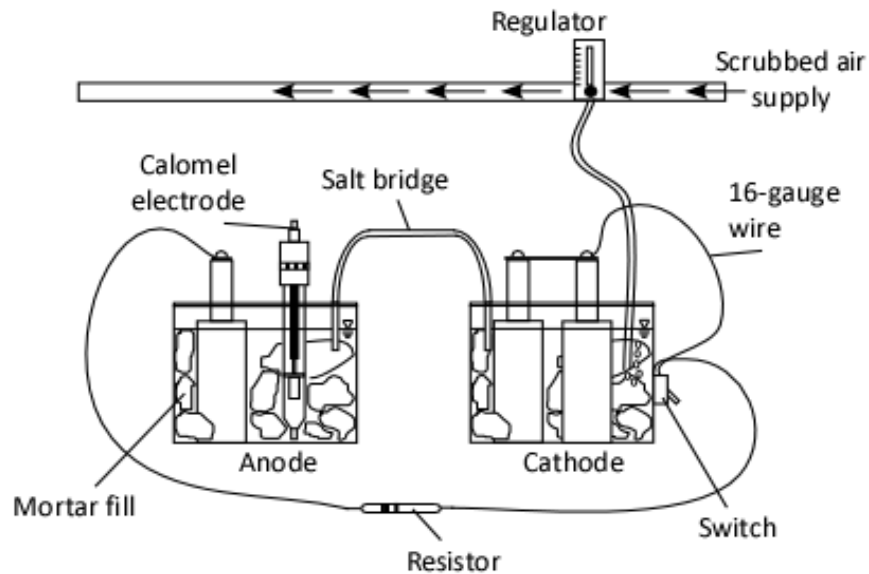

**Figure 4. Rapid Mini-Macrocell Setup.**

The two mortar-covered steel specimens in the cathode container shall be electrically connected using a 2-inch (50.8 mm) stainless steel pipe strap and stainless steel screws. A stainless steel O-ring terminal and 16-gauge insulated copper wire shall be used to connect the two specimens to an electrical switch. The specimens in the anode container shall also be connected to the switch using an O-ring terminal and copper wire over a 10-ohm resistor. The switch is kept in the on position to complete the circuit. It shall be turned off 2 hours before measurement of the open circuit potential of the sample.

Scrubbed air shall be obtained by passing pressurized air through a 1-M sodium hydroxide solution. This solution shall be prepared by mixing 0.0882 lb (40 g) of sodium hydroxide with 2.2046 lb (1000 g) of distilled water. Pressurized air can be connected to the bottom of a container using vinyl tubing and a barbed fitting. Perforated vinyl tubing can be used to bubble pressurized air through the solution inside the container. Vinyl tubing shall be

attached to the top of the container with a barbed fitting to convey the scrubbed air to the cathode containers by means of a series of smaller diameter vinyl tubing and air regulators. Test setups can then be stored on shelves for testing. A separate air line coming from the container can be used to feed scrubbed air to a sample set. [Figure 5](#) shows the rapid macrocell test setups placed on shelves.



**Figure 5. Rapid Macrocell Test Setup on the Rack.**

The mortar used to fill the anode and cathode containers should be the same used to cast the samples. Fill mortar shall be broken into 1- to 2-inch (25 to 50 mm) pieces.

Simulated concrete pore solution shall be prepared by mixing 0.0415 lb (18.81 g) of potassium hydroxide (KOH) and 0.0391 lb (17.87 g) of sodium hydroxide (NaOH) with 2.1491 lb (974.8 g) of distilled water ([Farzammehr 1985](#)). Do not add chloride unless specifically required. Cathode and anode containers shall be filled with mortar fill and simulated concrete solution to a depth of 3.72 inches (95 mm). Sodium chloride (0.1005 lb [45.6 g]) shall be added to 0.2642 gal (1 L) of simulated concrete pore solution (or similar ratios) that is used to fill the anode containers only. The cathode containers shall contain no chlorides.

For each test setup, one salt bridge shall be placed between the anode and cathode solutions to provide an ionic path for current flow. Salt bridges can be prepared following a procedure described by [Kahrs et al. \(2001\)](#). Salt bridges shall be made using 24-inch (0.6 m)



long flexible vinyl tubing with an outside diameter of 3/8 inch (9.5 mm). A semisolid gel shall be prepared by mixing 0.0099 lb (4.5 g) of agar and 0.061 lb (30 g) of potassium chloride (KCl) with 0.2205 lb (100 g) of distilled water and heating the solution on a hot plate. The solution shall be continuously stirred. After melting, place the agar solution into tubes, keeping the ends higher than the center of the tube to prevent discharge. These tubes shall be placed in boiling water for 4 hours, keeping the ends of the tubes out of the water. After removal from boiling water and after samples are cooled, the salt bridge shall be inspected for air bubbles and tested for conductivity using a direct-current (DC) power source connected to two beakers filled with a chloride solution. Non-conducting salt bridges shall not be used.

The open circuit potential and macrocell corrosion current of all samples shall be monitored for a minimum of 100 days of exposure. To determine the macrocell corrosion current, the voltage drop across the 10-ohm resistors shall be measured by connecting the positive lead of a voltmeter to the anode side and the negative lead to the cathode side. This information shall be documented for each sample; documentation shall include the date of testing and representative voltage reading.

After completion of the voltage drop readings, all switches shall be turned off. After a wait period of 2 hours, open circuit potential readings shall be collected using a voltmeter and a saturated calomel electrode. The saturated calomel electrode shall be inserted into the solution through the hole specifically drilled in the anode container lid. To determine the open circuit potential of the mortar-covered specimen in the anode container, the negative terminal of a voltmeter shall be connected to the steel specimen and the positive terminal shall be connected to the saturated calomel reference electrode using an alligator clip or a similar connector. After the open circuit potential readings from all the samples have been collected, the switches shall be turned on and left at the on position until the following reading. Voltage data shall be collected three times a week: Monday, Wednesday, and Friday.

To assess the relative performance of the different systems, it is necessary to plot the cumulative current flow versus time. Higher values of cumulative current flow indicate systems that are more susceptible to corrosion; lower values are less susceptible to corrosion.



### 3. CONCRETE CHLORIDE ION ASSESSMENT TEST

The concrete chloride ion assessment test (also known as the concrete corrosion inhibitor association test) uses a standard concrete cylinder with embedded reinforcement to assess the corrosion performance of various corrosion prevention products. Chloride solution is ponded on the top of the cylinder, resulting in one-dimensional transport of chloride ions. This procedure accelerates the time to corrosion by minimizing the concrete cover. The following procedure is used to fabricate and test these samples.

No. 4 (No. 13 metric) steel reinforcement shall be cut into 8-inch (200 mm) long pieces using a liquid-cooled band saw. One end of the specimens shall be drilled using a drill and a No. 27 drill bit. The hole shall be tapped to receive a 3/8-inch (9.5 mm) long, No. 8-32 stainless steel machine screw. Steel specimens shall be cleaned in ethyl alcohol using an ultrasonic cleaner. Two inches (50 mm) from each end of the steel specimens shall be covered with electroplater's tape, leaving a 4-inch (100 mm) long piece of specimen exposed for testing.

Plastic cylinder molds, 6 × 12 inches (150 × 300 mm), shall be used to cast the samples. Molds shall be drilled at 1.25 inches (31.75 mm) and 3.75 inches (95.25 mm) from the bottom using a 5/8-inch (15.875 mm) drill bit and drill; these holes will accept the steel specimens to be tested. Molds shall be cut along the holes and taped back together with electrical tape to make removal of the specimens from the molds easier. [Figure 6](#) shows the cylindrical mold prepared to cast the CCIA test samples.

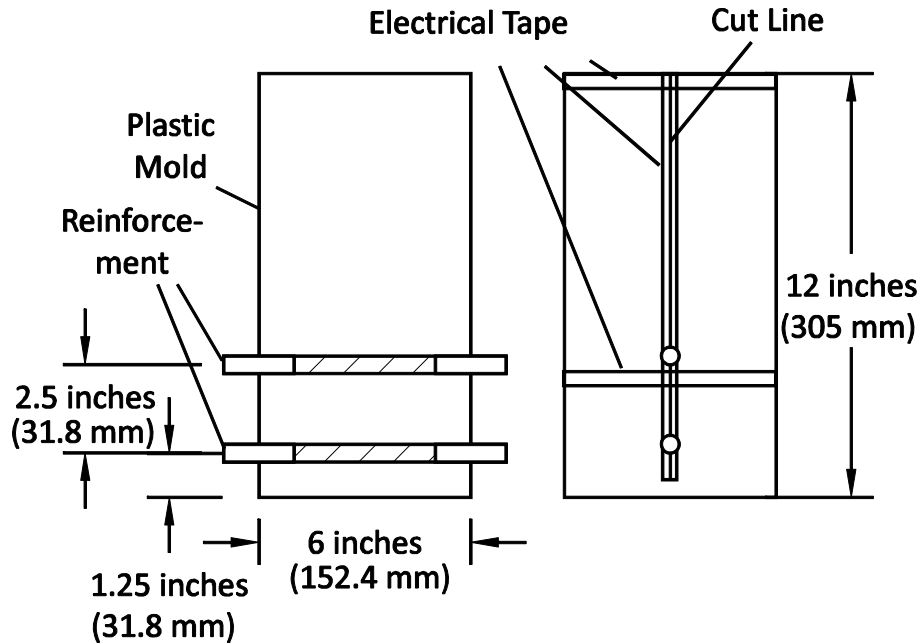

**Figure 6. Mold for CCIA Sample.**

Steel specimens shall then be inserted into the molds prior to casting, with the drilled and tapped ends of both specimens facing the same direction. The 4-inch (100 mm) long exposed surface shall be centered in the cylindrical molds. Mortar shall be mixed following ASTM C305, *Standard Practice for Mechanical Mixing of Hydraulic Cement Pastes and Mortars of Plastic Consistency*, and shall be placed into the molds in three layers. Each layer shall be consolidated using a 5/8-inch (15.875 mm) diameter steel rod, 25 times. After each layer is placed, the mold shall be tapped with a rubber mallet to remove air bubbles. After casting, samples shall be covered with wet burlap for 3 hours and then moved to a curing room at 73°F (23°C) and 98 percent RH. Samples shall be removed from molds the following day and shall be cured in an environment at 100 percent humidity for a total of 28 days.

At the end of the curing period, samples shall be removed from the curing room. Samples shall then be cut, using a water-cooled masonry saw, to leave a mortar cover of 0.75 inches (20 mm) over the top steel specimen. Cut portions of the samples shall be retained for later chloride content determination to determine the initial chloride content of samples before exposure to the chloride solution. Samples shall then be dried for 2 weeks at laboratory room temperature and humidity. A 4-inch (100 mm) PVC pipe shall then be cut into 3-inch

(75 mm) long pieces to be used as a chloride solution reservoir. At the end of the drying period, the chloride solution reservoirs shall be attached to the top of the samples using silicone caulk. After the silicone caulk has cured, the sample shall be coated with a two-part, high viscosity epoxy with the exception of the area inside the chloride solution reservoir.

The top reinforcement of each sample shall then be connected to an electrical switch, and be attached to the side of the sample using a No. 8-32 stainless steel screw, an O-ring electrical terminal, and a 2-inch (50 mm) long 16-gauge copper wire. A 10-ohm resistor shall be attached to the bottom reinforcement using a No. 8-32 stainless steel screw and two stainless steel washers at one end. At the other end, the resistor shall be clamped to a 2-inch (50 mm) long 16-gauge copper wire that is connected to the switch. Another 2-inch (50 mm) long copper wire with a female banana plug shall be attached to the top reinforcement of each sample. Figure 7 shows the CCIA test sample.

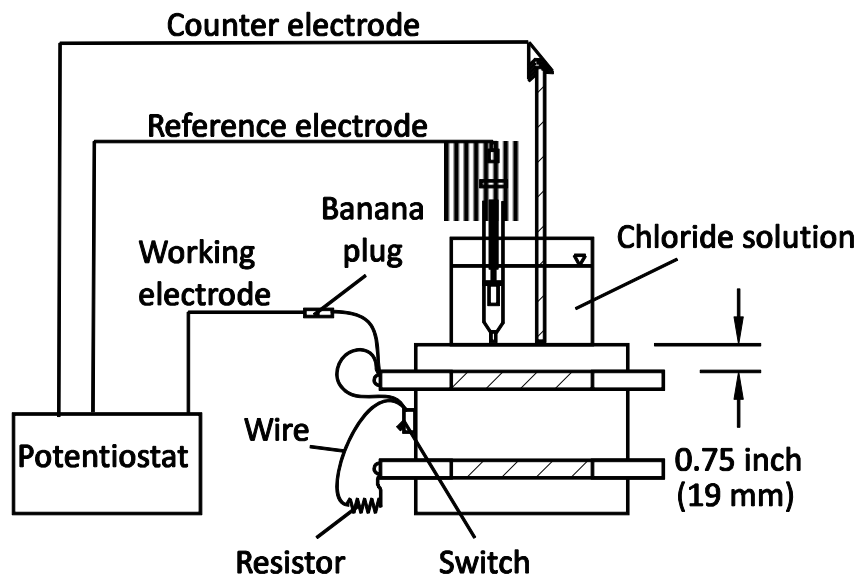

Figure 7. CCIA Test Sample and Setup.

Samples shall then be stored on steel wire shelves where the bottoms of the samples are exposed to air. Samples shall be ponded with a 3 percent sodium chloride solution every Monday morning and dried every Friday morning, exposing the samples to a 4-day wet and 3-day dry weekly cycle. An easy approach to drying samples is to use a wet/dry shop vacuum.

Electrochemical measurements shall then be performed every Tuesday (1 day after ponding samples). The 3 percent sodium chloride solution shall be prepared by mixing 0.106 oz (3 g) sodium chloride with 3.42 oz (97 g) distilled water.

The macrocell corrosion current, the open circuit potential, and the polarization resistance ( $R_p$ ) of the samples shall be measured weekly. While the electrical switch is in the on position, the voltage drop across the resistor shall be measured by connecting the positive terminal of a voltmeter to the bottom reinforcement and the negative terminal to the other end of the resistor. Macrocell current shall be calculated by dividing the voltage drop by the resistance of the resistor (10 ohms). After measuring the voltage drop across the resistor, the electrical switch shall be turned off. Two hours after the voltage reading is taken, the open circuit potential and  $R_p$  of the top reinforcement shall be measured using a potentiostat. A saturated calomel reference electrode and graphite counter electrode shall be inserted into the sodium chloride solution reservoir, and the top reinforcement shall be connected to the potentiostat as the working electrode. The potentiostat shall be programmed to first determine the open circuit potential of the steel specimen against the calomel electrode for 60 seconds. It shall then be programmed to maintain the potential of the specimen constant at the last measured open circuit potential level for 30 seconds and sweep the potential scan from  $-15$  millivolt (mV) to  $+15$  mV from the open circuit potential to determine the  $R_p$ . These setups can be easily programmed into most potentiostats. The scan rate shall be 0.167 mV/second. At the completion of electrochemical measurements, the electrical switch shall be turned to the on position.

The criterion to determine the initiation of corrosion (activation criteria) is that the macrocell current is greater than 1 microamp ( $\mu\text{A}$ ) and either there is a sudden drop in the open circuit potential ( $<-350$  mV vs saturated calomel electrode (SCE)) or a sharp decrease in  $R_p$  ( $<5$  kiloOhm). When a sample satisfies this activation criterion for 2 consecutive weeks, testing shall be stopped and the sample shall be cut at the level of the top reinforcement (after removal of the chloride solution reservoir). A minimum of 0.35 oz (10 g) of mortar powder shall be collected from the mortar that is directly adjacent to the reinforcement sample. This sample will be used to determine the chloride content and shall be collected using a profile grinder. The mortar powder shall be collected from a depth of 78.7 mils (2 mm) as shown in [Figure 8](#), and its chloride content shall be analyzed following ASTM C1152, *Standard Test Method for Acid-Soluble Chloride in Mortar and Concrete*.

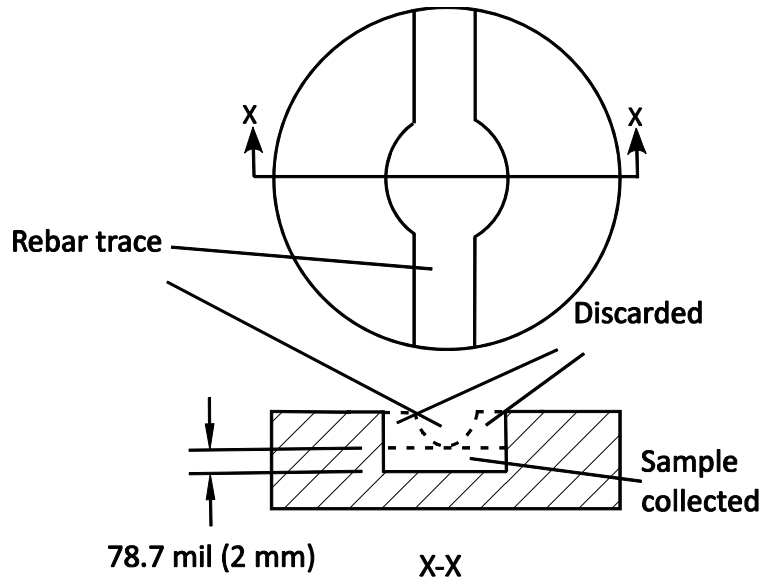

**Figure 8. Mortar Powder Collected from the Top Part.**

A comparison of the times to corrosion activation demonstrates the results. Shorter times to activation indicate the system is more susceptible to corrosion than longer times. Also, critical chloride threshold values can be compared. Higher values indicate higher resistance to chloride-induced corrosion.





#### **4. ACCELERATED CHLORIDE THRESHOLD TEST**

The accelerated chloride threshold test accelerates the transport of chlorides into a mortar using electrical migration. A subsystem of the test is used, independent of the reinforcement being evaluated, which draws the chlorides into the mortar, thereby reducing the test time. In addition, a separate subsystem evaluates the corrosion activity of the metallic samples being evaluated. The following procedure is used to assess the corrosion susceptibility of different materials.

Steel reinforcement, used to assess the corrosivity of a material system, shall be cut to 0.75-inch (19 mm) long specimens using a band saw with a liquid cooling system to prevent heating of steel specimens. Steel specimens shall then be drilled and tapped using a #38 drill bit and #5-40 tap. After being cleaned in ethyl alcohol using an ultrasonic cleaner, specimens shall be attached to #5-40 threaded stainless steel rods. A rectangular area approximately  $0.35 \times 0.67$  inches ( $9 \times 17$  mm) in size shall be marked as the exposure surface on the top surface of the steel specimens. Steel specimens (with the exception of the exposure surface) and part of the threaded rods shall then be coated using a two-part epoxy as shown in [Figure 9](#). The dimensions of the exposed surface shall be measured for each specimen after the application of epoxy coating.

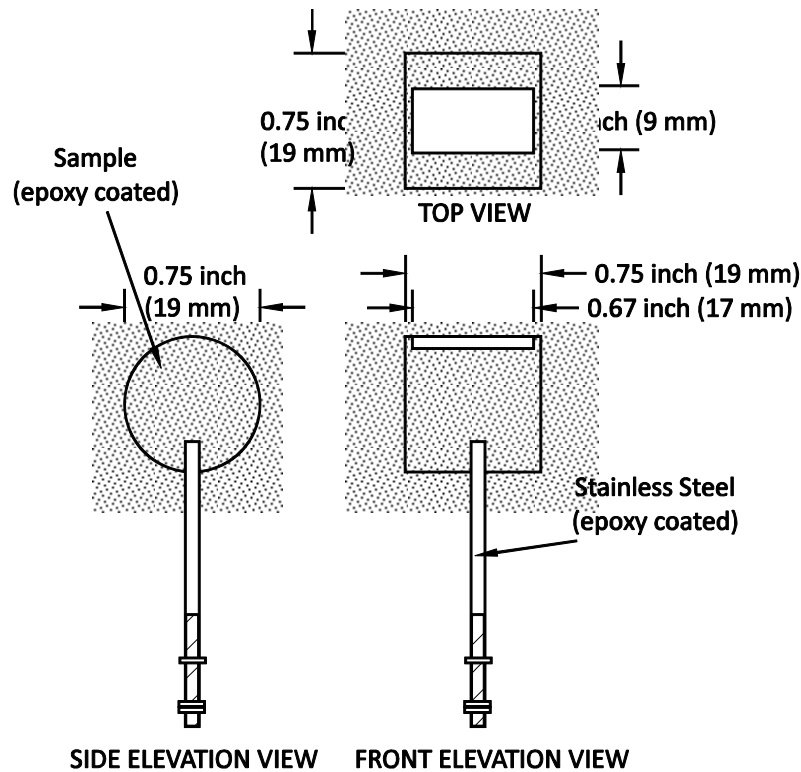
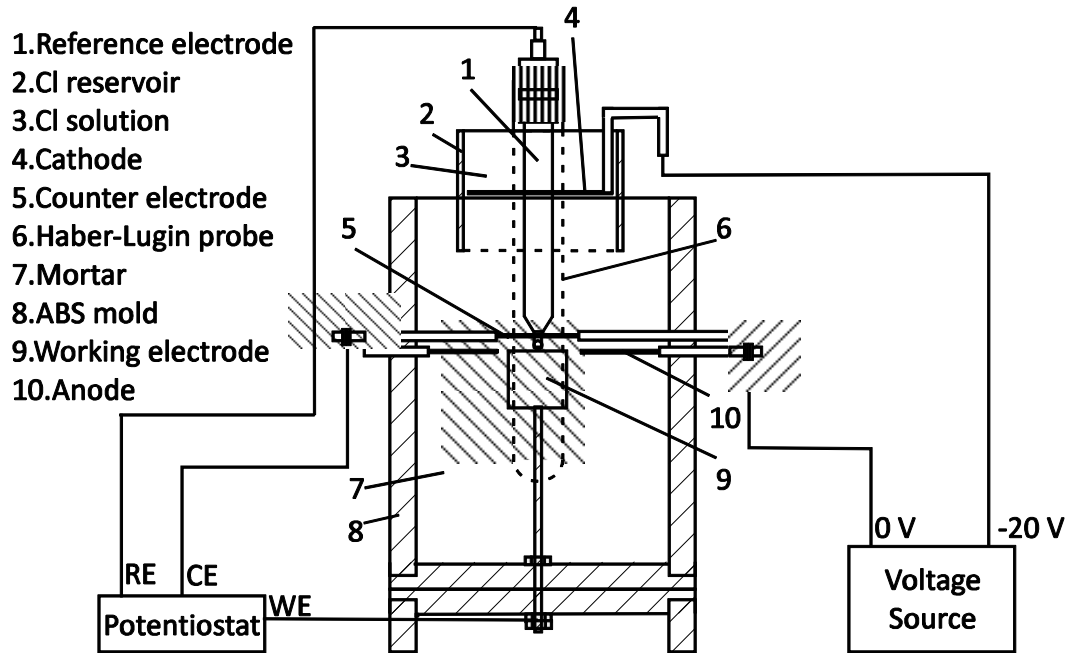

Figure 9. Steel Specimen of ACT Test (Pillai 2003).

A three-part, prefabricated 3 × 4.5 inch (75 × 115 mm) acrylonitrile-butylene-styrene (ABS) cylinder mold shall be used to cast the mortar samples. Reference Electrode (RE); Counter Electrode (CE); Working Electrode (WE); Chloride (Cl)

Figure 10 shows the three-part cylinder mold and different parts of the ACT sample. Part number 9 in Figure 10 shows the steel specimen attached to the bottom part of the cylinder mold. The anode (part number 10) is prepared using a 2.8-inch (69 mm) diameter Nichrome mesh with a 1 × 1 inch (25 × 25 mm) section removed from the center. The anode mesh disk shall be soldered to two copper wires and attached to the middle part of the ABS mold. The 1 × 1 inch (25 × 25 mm) section removed from the anode shall then be soldered to two copper wires and shall be used as the counter electrode (part number 5). The counter electrode shall be attached to the top part of the ABS mold. All copper wires and connections shall be coated with a two-part epoxy.



Reference Electrode (RE); Counter Electrode (CE); Working Electrode (WE); Chloride (Cl)

**Figure 10. ACT Test Sample (Pillai 2003).**

Mortar mixtures shall be batched and mixed following ASTM C305. The bottom part of the ABS molds shall be filled with three layers of mortar. After mortar is placed in the molds, the molds shall be tapped 10 times with a rubber mallet to remove entrapped air. Approximately 0.3 inches<sup>3</sup> (5 cm<sup>3</sup>) of mortar shall be placed in the mold before the placement of the middle part of the ABS mold, forcing mortar through the anode mesh disk.

**Haber-Lugin probes (part number 6 in Reference Electrode (RE); Counter Electrode (CE); Working Electrode (WE); Chloride (Cl)**

Figure 10) shall then be inserted through a pre-drilled hole in the middle part of the ABS mold. The Haber-Lugin probe is a glass tube with a glass tip extending from its side into the mortar. The tip of the probe is placed approximately 1/32 inch (1 mm) above the exposed surface of the steel specimen and shall be fitted with a porous frit. A heat shrinking tube shall be used to hold the frit and probe together, and no leakage should occur at this location. Figure 11 shows the Haber-Lugin probe. When filled with a conductive solution, the Haber-Lugin probes acts as a conductive bridge between the reference electrode (part number 1) and the steel specimen (working electrode) for polarization resistance measurements.

Approximately 0.6 inches<sup>3</sup> (10 cm<sup>3</sup>) of mortar shall be placed on the steel specimen and Haber-Lugin probe before the placement of the top part of the mold, forcing mortar through the counter electrode mesh. The top part shall then be filled with mortar and tapped slightly. A 2-inch (50 mm) diameter plastic mold shall be used as the chloride solution reservoir system (part number 2 in Reference Electrode (RE); Counter Electrode (CE); Working Electrode (WE); Chloride (Cl)

Figure 10). These reservoirs shall be inserted 0.25 inches (6 mm) into the mortar at the center of the ABS mold.

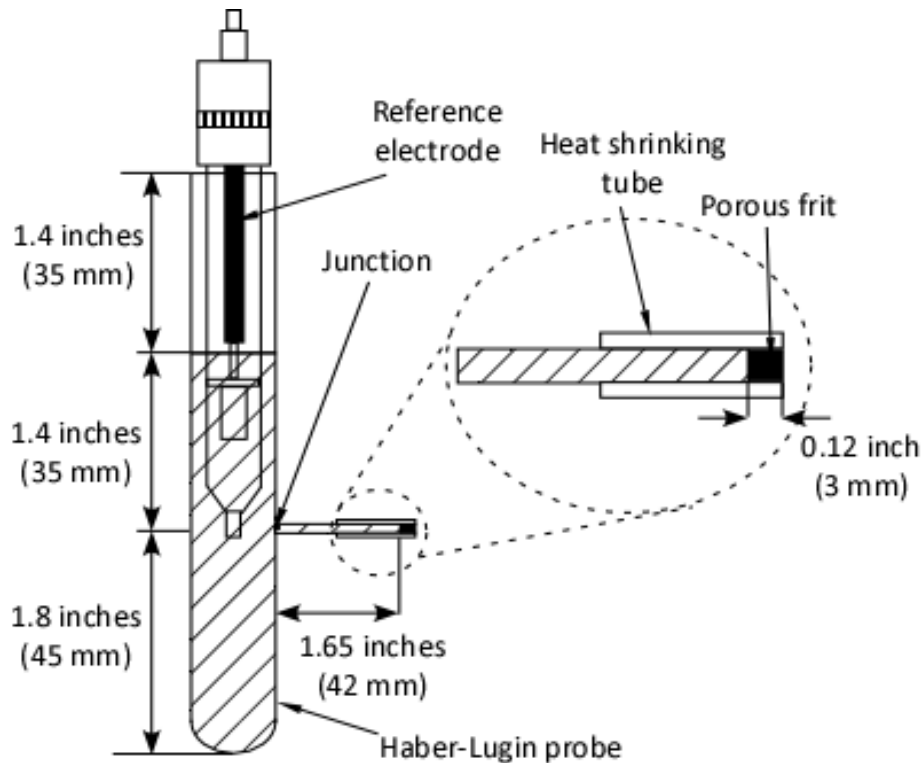

Figure 11. Haber-Lugin Probe and Reference Electrode (Pillai 2003).

After casting, samples shall be moved immediately to a curing room and stored at 73°F (23°C) and 98 percent RH for 28 days; the tops of the samples should be covered with plastic sheeting. Nichrome mesh with a 1.8-inch (44 mm) diameter shall be used as the cathode (part number 4 in Figure 10). The cathode mesh disks soldered to copper wires shall be placed into the chloride solution reservoirs at the end of the curing period. Reservoirs shall be filled with a 3.5 percent by weight chloride solution that shall be prepared by mixing 2.16 oz (61.23 g) of

sodium chloride (NaCl) in 0.26 gal (1 l) of distilled water. Haber-Lugin probes shall be filled with a 0.1 percent by weight chloride solution.

The cathode and anode mesh disks of the samples shall be connected to the positive and ground terminals of a DC power source through distribution boxes (distribution boxes are needed only if number of samples being tested is greater than the number of power sources). Saturated calomel electrodes shall be placed in the Haber-Lugin probes as the reference electrodes. Reference electrodes, steel specimens (working electrodes), and counter electrodes shall be connected to a potentiostat as shown in [Figure 10](#). The initial polarization resistance of the samples shall then be measured. A voltage difference of 20 V shall be applied between the anode and cathode of each sample for 6-hours periods with a wait period between voltage applications of 42 hours. After six voltage applications, electrochemical measurements shall be performed. The potentiostat shall be programmed to determine the open circuit potential of the steel specimen against the calomel electrode for a period of 60 seconds, maintain the potential of the specimen constant at the last measured open circuit potential level for 30 seconds, and then sweep the potential scan from  $-15$  mV to  $+15$  mV against the open circuit potential to determine the  $R_p$ . The scan rate shall be 0.167 mV/second. Cumulative hours of voltage application and the measured  $R_p$  values over time shall be recorded and plotted.

A statistically significant increase of the reciprocal of  $R_p$  shall be used as the activation criterion. When a sample is deemed active (initiation of corrosion), testing shall be stopped and the sample disconnected from the power source and potentiostat.

To determine if the sample is activated, plot the first five inverse polarization resistance values from the tests against the cumulative time of applied voltage and draw the best fitting line as shown below. Determine the coefficients “a” and “b.”

$$y=a+bx$$

where  $y=\frac{I}{R_p}$  and  $x$  is the cumulative time of the applied voltage. Using the best fitting line,

estimate the inverse polarization of the next measurement  $\left(\frac{I}{R_p}\right)^\zeta$ . If the next measurement is

greater than  $\left(\frac{I}{R_p}\right)^\zeta + D$  (defined next), then corrosion has initiated; otherwise continue testing.

All of the previously measured data points shall be used to establish the new best fitting line and to repeat the process. The factor  $D$  can be defined as follows:

$$D=t_{0.25,n-2}\sqrt{\hat{\sigma}^2\left[1+\frac{I}{n}+\frac{(x_0-\bar{x})^2}{S_{xx}}\right]}$$

where  $x$  is the cumulative time of the data points for all earlier measurements,  $y$  is  $\frac{I}{R_p}$ ,  $x_0$  is the

cumulative time at which  $\frac{1}{R_p}$  is being estimated,  $n$  is the number of data points used to establish

the best fitting line, and  $\bar{x}=\left(\frac{I}{n}\right)\sum_{i=1}^n x_i$ ,  $t_{0.25,n-2}$  is the value that can be determined using a

t-distribution table or the TINV(0.25,n-2) function as follows:

$$S_{xx}=\sum_{i=1}^n(x_i-\bar{x})^2$$

$$\hat{\sigma}^2=\frac{I}{n-2}\left\{\sum_{i=1}^n y_i^2 - n\bar{y}^2 - b\left[\sum_{i=1}^n y_i(x_i-\bar{x})^2\right]\right\}$$

Active samples shall then be broken at the level of anode mesh disk and steel specimen; i.e., the middle and top parts of the ABS mold shall be separated from the bottom mold section. Using a profile grinder, mortar shall be ground into a powder from the middle part of the mortar in the ABS mold (from the section that is adjacent to the steel specimen). Grinding of the mortar shall be done within 7 days after activation. Ground mortar powder (approximately 0.053 oz [1.5 g]) shall be collected from a depth of 78.7 mils (2 mm). The chloride content of the ground mortar shall be determined using a chloride ion specific electrode following the rapid chloride content determination method developed by the Strategic Highway Research Program ([Herald et al. 1993](#)).





## **5. SUMMARY**

As part of Project 0-4825, several accelerated test procedures were evaluated to determine their applicability to assessing the corrosion performance of different material combinations. The MM test procedure was identified as the fastest test procedure that provides reasonable, comparative results. This manual provides a procedure for making and testing MM samples. In addition to the MM samples, if more quantitative information is needed, either the CCIA or ACT test may be used. This manual provides the procedures for performing these tests as well.

These accelerated tests can be performed over shorter periods and can provide comparative information on different systems. Not all combinations of material system improvement approaches (e.g., corrosion resistant steel, inhibitors, water-cement ratio) were evaluated. The user will have to use judgment in performing these tests to achieve the objective of comparing the performance of these different systems.



## REFERENCES

- Farzammehr, H. (1985). *Pore Solution Analysis of Sodium Chloride and Calcium Chloride Containing Cement Pastes*, University of Oklahoma, Norman, Oklahoma.
- Herald, S.E., M. Henry, I.L. Al Qadi, R.E. Weyers, M.A. Feeney, S.F. Howlum, and P.D. Cady (1993). *Condition Evaluation of Concrete Bridges Relative to Reinforcement Corrosion, Volume 6: Method for Field Determination of Total Chloride Content*, Report SHRP-S-328, Strategic Highway Research Program (SHRP), National Research Council, Washington, D.C.
- Kahrs, J.T., D. Darwin, and C.E. Locke (2001). *Evaluation of Corrosion Resistance of Type 304 Stainless Steel Clad Reinforcing Bars*, University of Kansas Center for Research, Inc., Lawrence, Kansas.
- Pillai, R.G. (2003). *Accelerated Quantification of Critical Parameters for Predicting the Service Life and Life Cycle Costs of Chloride-Laden Reinforced Concrete Structures*, Master's Thesis, Texas A&M University, College Station, Texas.

