

1. Report No. FHWA/TX-08/0-4746-3		2. Government Accession No.		3. Recipient's Catalog No.	
4. Title and Subtitle NON-VITAL ADVANCE RAIL PREEMPTION OF SIGNALIZED INTERSECTIONS NEAR HIGHWAY-RAIL GRADE CROSSINGS: TECHNICAL REPORT				5. Report Date June 2007 Published: September 2007	
				6. Performing Organization Code	
7. Author(s) Leonard G. Ruback, Kevin Balke, and Roelof Engelbrecht				8. Performing Organization Report No. Report 0-4746-3	
9. Performing Organization Name and Address Texas Transportation Institute The Texas A&M University System College Station, Texas 77843-3135				10. Work Unit No. (TRAIS)	
				11. Contract or Grant No. Project 0-4746	
12. Sponsoring Agency Name and Address Texas Department of Transportation Research and Technology Implementation Office P.O. Box 5080 Austin, Texas 78763-5080				13. Type of Report and Period Covered Technical Report: September 2003 – August 2006	
				14. Sponsoring Agency Code	
15. Supplementary Notes Project performed in cooperation with the Texas Department of Transportation and the Federal Highway Administration. Project Title: Non-Vital Advance Rail Preemption of Signalized Intersections near Highway-Rail Grade Crossings URL: http://tti.tamu.edu/documents/0-4746-3.pdf					
16. Abstract The Texas Department of Transportation (TxDOT) primarily uses simultaneous preemption of traffic signals near highway-rail grade crossings to clear queued vehicles prior to the arrival of a train at the crossing. At some intersections, 20 seconds of advanced warning may not be sufficient to allow the traffic signal to clear pedestrians using the normal clearance intervals between phases. The research developed an alternative method (non-vital advance preemption) of ensuring adequate pedestrian clearance in the presence of an approaching train without interfering with the normal preemption sequence at the intersection or installing costly additional track circuitry needed to provide advance preemption. Two strategies were investigated to ensure pedestrian clearance time. The first utilizes a lower-level preemption sequence to guarantee full pedestrian clearance to a terminating phase before the traffic signal starts the preemption sequence. The second strategy uses the pedestrian-omit feature to prevent the controller from activating the pedestrian interval if there is not sufficient time in advance of the start of the preemption sequence to provide full pedestrian clearance.					
17. Key Words Preemption, Railroad, Train, Pedestrian, Highway-Rail Intersection, Highway-Rail Grade Crossing			18. Distribution Statement No restrictions. This document is available to the public through NTIS: National Technical Information Service Springfield, Virginia 22161 http://www.ntis.gov		
19. Security Classif.(of this report) Unclassified		20. Security Classif.(of this page) Unclassified		21. No. of Pages 122	22. Price

**NON-VITAL ADVANCE RAIL PREEMPTION OF SIGNALIZED
INTERSECTIONS NEAR HIGHWAY-RAIL GRADE CROSSINGS:
TECHNICAL REPORT**

by

Leonard G. Ruback
Research Scientist
Texas Transportation Institute

Kevin Balke
Center Director
Texas Transportation Institute

and

Roelof Engelbrecht
Associate Research Scientist
Texas Transportation Institute

Report 0-4746-3

Project 0-4746

Project Title: Non-Vital Advance Rail Preemption of Signalized Intersections near
Highway-Rail Grade Crossings

Performed in cooperation with the
Texas Department of Transportation
and the
Federal Highway Administration

June 2007

Published: September 2007

TEXAS TRANSPORTATION INSTITUTE
The Texas A&M University System
College Station, Texas 77843-3135

DISCLAIMER

The contents of this report reflect the views of the authors, who are responsible for the facts and the accuracy of the data presented herein. The contents do not necessarily reflect the official view or policies of the Federal Highway Administration (FHWA) or the Texas Department of Transportation (TxDOT). This report does not constitute a standard, specification, or regulation. The researcher in charge was Leonard Ruback.

None of the product selections identified in this report should be construed as product endorsements. Products were selected or provided based on their stated capability and should not necessarily be considered to reflect a “best of breed” choice.

ACKNOWLEDGMENTS

The authors would like to thank the Texas Department of Transportation and the Federal Highway Administration for sponsoring the research, and the following individuals from TxDOT who provided guidance and expertise during various phases of the research:

- Tom Beeman, who served as the project director;
- David Valdez, who served as the project coordinator;
- Jorge Salinas, Wally Shaw, Sandra Kaderka, and Wade Odell, who participated as members of the Project Monitoring Committee.

A special thanks is extended to Dexter Turner, Matt Cox, and Tony Parlamas of the TxDOT Corpus Christi District for their support during the Alice, Texas, field deployment segment of the project.

TABLE OF CONTENTS

ACKNOWLEDGMENTS	vi
List of Figures	viii
List of Tables	x
CHAPTER 1: INTRODUCTION	1
Tradeoffs	3
Safety-critical, Vital, and Fail-safe Systems	4
Non-railroad Train Detection	5
CHAPTER 2: NON-VITAL ADVANCE PREEMPTION SYSTEMS	9
Non-Vital Advance Preemption Strategy – Type 1	11
Non-Vital Advance Preemption Strategy – Type 2	15
CHAPTER 3: SIMULATION STUDY OF NON-VITAL ADVANCE PREEMPTION	27
Treatments	27
Study Approach	28
Measures Of Effectiveness	36
Simulation Results	36
CHAPTER 4: NON-VITAL ADVANCE PREEMPTION SYSTEM DESIGN	41
NVAP System Concept of Operation	41
NVAP System Architecture	43
NVAP Architecture – Layer 1	47
NVAP Architecture – Layer 2	50
NVAP Architecture – Layer 3	63
Rail Corridor Simulation Packages	65
CHAPTER 5: TEST IMPLEMENTATIONS	67
College Station Testbed	68
Alice Testbed	79
CHAPTER 6: CONCLUSION AND RECOMMENDATIONS	87
APPENDIX A: NON-VITAL ADVANCE PREEMPTION SYSTEM SPECIFICATION	91
APPENDIX B: IMPLEMENTATION GUIDELINES	95
APPENDIX C: MULTIPLEXING NVAP DATA WITH AN INTERSECTION CLOSED LOOP CONTROL SYSTEM	99
APPENDIX D: NVAP-APPROACHING TRAIN INFORMATION (NVAP-ATI) MESSAGE DEFINITION	103
APPENDIX E: NVAP-SIMPLIFIED ATI (NVAP-SATI) MESSAGE DEFINITION	107
REFERENCES	109

LIST OF FIGURES

	<i>Page</i>
Figure 1. Variability in Expected Warning Time.	10
Figure 2. Signal Phase Sequence under Simultaneous Preemption.	12
Figure 3. Identification of the Activation Point for the NVAP – Type 1 Algorithm.	13
Figure 4. Functional Flow Diagram Depicting the Operations of NVAP – Type 1.	14
Figure 5. Data Flow Diagram for NVAP – Type 1.	15
Figure 6. Scenario Where Pedestrian Interval Can Be Fully Serviced Prior to Preemption Call.	16
Figure 7. Scenario Where Pedestrian Interval Cannot Be Fully Serviced Prior to Preemption Call.	17
Figure 8. Top-Level Functional Diagram of NVAP – Type 2 Control Strategy.	19
Figure 9. Data Flow between Functional Elements in the NVAP –Type 2 Algorithm.	20
Figure 10. Illustration of Time to Preemption and Required Advance Warning Time in NVAP – Type 2.	23
Figure 11. Example of Hardware-in-the-Loop Setup Used in the Simulation Study.	29
Figure 12. Screen Capture of Simulated Intersection of George Bush Drive and Wellborn Road in College Station, Texas.	30
Figure 13. Volumes and Speed Parameters of Vehicles, Pedestrian, and Trains Used in Simulation Evaluation.	31
Figure 14. Phasing Sequence Diagram for Normal and Simultaneous Preemption.	34
Figure 15. NVAP System Block Diagram.	42
Figure 16. NVAP System Data Flow.	43
Figure 17. Zone of Interest.	47
Figure 18. Train Detection Package Block Diagram.	49
Figure 19. NVAP System Microcontroller.	52
Figure 20. NVAP Controller Process Diagram.	53
Figure 21. Preempt-based NVAP System Architecture.	56
Figure 22. Logic Flow Diagram.	59
Figure 23. Rail Corridor with Preempted Intersections and No Trains.	59
Figure 24. Train Enters Corridor.	60
Figure 25. Preemption at Site 1.	61
Figure 26. Train Arrives at Site 1.	61
Figure 27. Preemption at Site 2.	61
Figure 28. Train Arrives at Site 3.	62
Figure 29. College Station Test Location.	68
Figure 30. Holleman Drive Intersection.	69
Figure 31. Decision to Preemption Time.	71
Figure 32. Decision to Preemption Time for Southbound Trains.	72

Figure 33. Decision to Preemption for Northbound Trains.	73
Figure 34. Pedestrian Clearance Time Prior to a Train.	76
Figure 35. Track Clearance Phase Length Prior to Train.	77
Figure 36. Alice, Texas, Deployment.	79
Figure 37. Reynolds Street NVAP System Location.	80
Figure 38. Preemption Reliability.	81
Figure 39. Travel Time from Corridor Intersections to Reynolds Street.	83
Figure 40. IEEE 1550-2002 Highway-Rail Intersection (HRI) Interface Architecture.	92
Figure 41. Off Right of Way NVAP Architecture.	93
Figure 42. Poll / Response Cycle for Intersection Control.	99
Figure 43. Cabinet Layout Utilizing Terminal Server.	101

LIST OF TABLES

	<i>Page</i>
Table 1. Sensor Technologies Evaluated in the Moorhead Area Integrated Train Detection and Traffic Control System Project.	7
Table 2. Connector and Pin Locations of the “Phase Next” Outputs in a TS 1 Controller.	21
Table 3. Phase and Pedestrian Signal Timing Data for Non-Preempt Operations.	32
Table 4. Interval Times Programmed into Preempts 1 and 2 to Provide Simultaneous and Non-Vital Preemption.	35
Table 5. Controller Settings Programmed into Preempts 1 and 2 to Provide Simultaneous and Non-Vital Preemption.	35
Table 6. Measures Used to Evaluate the Effectiveness of NVAP Treatments on Intersection Safety and Operations.	36
Table 7. Effects of the Different Preemption Strategies on Pedestrian and Vehicle Phase Truncations.....	37
Table 8. Average Reduction in Pedestrian and Vehicle Phase Intervals When a Truncation Occurs.	38
Table 9. Average Intersection Delay Produced by Each Preemption Strategy.....	39
Table 10. Results of Statistical Analysis of the Impacts of the NVAP Strategies on Average Intersection Delay.	39
Table 11. Average Queue Length Produced by Each Preemption Strategy.	40
Table 12. Results of Statistical Analysis of the Impacts of the NVAP Strategies on Queue Lengths Crossing the Railroad Tracks.	40
Table 13. Estimated Time (in seconds) to Preemption Matrix.	62
Table 14. Distribution of Trains within a Time Interval around the Mean.....	74
Table 15. Effect of Acceleration and Deceleration on Predictions.....	75
Table 16. Summary of NVAP Type – 2 Results.....	78
Table 17. Estimated Train Travel Times (in seconds) between Locations.....	80
Table 18. Distribution of Travel Times around the Mean for Alice Deployment.	84
Table 19. Summary of Prediction Probability.	88
Table 20. Terminal Server Port Assignment Matrix.....	101

CHAPTER 1: INTRODUCTION

At traffic signals near railroad grade crossings there exists the potential of traffic queues backing up across the tracks due to the interrupted service provided by the traffic signal. It is therefore possible that stationary vehicles may be located in the path of an oncoming train. By providing an electrical interconnection circuit between the railroad warning equipment and the traffic signal controller, it is possible to implement rail preemption in the traffic signal controller. Preemption is the transfer of signal control to a special control mode designed to clear stationary vehicles out of the crossing (1,2).

Two types of preemption can be used: simultaneous preemption and advance preemption. Under simultaneous preemption, notification of an approaching train is forwarded to the highway traffic signal controller unit or assembly and railroad active warning devices at the same time (1,2). Simultaneous preemption is typically used where the minimum warning time needed for the operation of the railroad active warning devices (flashing lights and gates) is sufficiently long to clear stationary vehicles safely out of the crossing. Section 49, Part 234.225 of the U.S. Code of Federal Regulations requires that:

“A highway-rail grade crossing warning system shall be maintained to activate in accordance with the design of the warning system, but in no event shall it provide less than 20 seconds warning time for the normal operation of through trains before the grade crossing is occupied by rail traffic” (3).

Advance preemption is typically used if more than 20 seconds of warning time are needed to safely clear stationary vehicles out of the crossing. Under advance preemption, railroad equipment forward notification of an approaching train to the highway traffic signal controller unit or assembly for a period of time prior to activating the railroad active warning devices. This period of time is the difference in the maximum preemption time required for highway traffic signal operation and the minimum warning time needed for railroad operations and is called the advance preemption time (1,2). For simultaneous preemption the advance preemption time is zero. Advance preemption is required when there is not enough time available under simultaneous preemption to clear traffic safely off the tracks. The highway authority typically requests advance preemption

time from the railroad if their calculations indicate that the minimum warning time is insufficient to clear the traffic safely off the tracks.

Railroads typically only supply simultaneous preemption to provide the federally mandated minimum warning time of 20 seconds. In most cases, there is a significant additional cost involved in upgrading simultaneous preemption to advance preemption, typically in the range of \$20,000 to \$300,000, depending on the distance to adjacent crossings and overall track complexity, and the agency requesting advance preemption usually bears this cost.

To ensure that previous work is considered in this project, a literature search was performed using the Transportation Research Board's Transportation Information Service (TRIS) database, the SilverPlatter Information's WebSPIRS™ Transport databases, and a general internet search using the Google™ search engine. In total, researchers evaluated more than fifty references, many of which are referenced below. Major standards and guidelines addressing rail preemption of traffic signal control include:

- *The Manual on Uniform Traffic Control Devices (MUTCD) - Millennium Edition (1)*. Section 4D.13 addresses Preemption and Priority Control of Traffic Control Signals while Part 8 addresses Traffic Controls for Highway-Rail Grade Crossings.
- *The American Railway Engineering and Maintenance of Way Association (AREMA) Communications & Signals (C&S) Manual (2)*. Part 3.1.10 addresses Recommended Functional/Operating Guidelines for Interconnection between Highway Traffic Signals and Highway-Rail Grade Crossing Warning Systems.
- *Highway/Rail Grade Crossing Technical Working Group (TWG) Guidance on Traffic Control Devices at Highway-Rail Grade Crossings (4)*. The report is intended to provide guidance to assist engineers in the selection of traffic control devices or other measures at highway-rail grade crossings.
- *Preemption of Traffic Signals at or Near Railroad Grade Crossings with Active Warning Devices (5)*. This Proposed Recommended Practice by the Institute of Transportation Engineers (ITE) supplements the requirements set forth in the MUTCD and other reference books regarding the use of preemption of traffic

signals at or near active warning grade crossings. An update to this Recommended Practice is currently being finalized (6).

- *Railroad-Highway Grade Crossing Handbook* (7). In Chapter 5, Section C.5 addresses the preemption of traffic signals near highway-rail grade crossings while Section C.6 addresses trail detection systems.

As far as researchers could ascertain from the literature survey, no public agencies are actively pursuing the approach of using non-vital advance preemption (NVAP) to augment existing simultaneous rail preemption of traffic signals near grade crossings. A few non-railroad train detection systems have been deployed, but those systems are all used as input to advance traveler information systems (8,9,10) or as a method to upgrade previously passive crossings to active warning control without preemption (11).

TRADEOFFS

Due to limited budgets and the increasing need to upgrade passive crossings with active warning devices, advance preemption is typically only provided (and funded by the highway authority) to address primary safety concerns; that is, to ensure that vehicles have enough time to move off the tracks before the arrival of the train. Budgets simply do not allow for the provision of advance preemption in “nice to have” cases, for example to provide full pedestrian clearance intervals, or to avoid gates descending on stationary or slow-moving vehicles (12).

Section 4D.13 of the MUTCD Millennium Edition (1) permits the shortening or omission of any pedestrian walk interval and/or pedestrian change interval during transitioning into preemption control. Section 8C-6 of the 1988 edition of the MUTCD stated that this concession is based on the concept of “relative hazard” and is made to ensure that the preemption sequence reaches the track clearance interval as soon as possible to clear traffic out of the crossing before the arrival of the train (13). However, the shortening or omission of the pedestrian clearance intervals has safety implications, most notably the possibility of stranding pedestrians in the roadway while a conflicting vehicular movement (usually the track clearance phase) receives green. Also, in the Federal Railroad Administration’s current School Bus Safety Alert (14) and Truck Driver Safety Alert (15), drivers of school buses and trucks are advised as follows:

“If the gate comes down after you have started across, drive through it even if it means breaking the gate—the gate is designed to break.”

Obviously, stranding pedestrians in the roadway and advising drivers to drive through descending gates is not ideal from a safety point of view, and are illustrative of the tradeoffs that agencies have to consider when deciding whether to provide advance preemption at the associated cost premium. However, it should be noted that stranding pedestrians in the roadway or driving through descending gates is considered less critical from a safety perspective than not providing enough time for vehicles to move off the tracks before the arrival of the train.

SAFETY-CRITICAL, VITAL, AND FAIL-SAFE SYSTEMS

From a safety engineering point of view the provision of adequate time to move vehicles out of the way of a train can be considered a safety-critical function, while providing full pedestrian clearance times or avoiding gates descending on stationary or slow-moving vehicles can be considered a non safety-critical function. According to Section 3.1 of Institute of Electrical and Electronics Engineers (IEEE) Standard 1570-2002, safety-critical is “a term applied to system or function, ... the incorrect performance of which may result in an unacceptable risk of a hazard.” Safety-critical functions are closely tied to vital functions. IEEE 1570-2002 defines a vital function as “a function in a safety-critical system that is required to be implemented in a fail-safe manner” and fail-safe as “a design philosophy applied to safety-critical systems such that the result of a hardware failure or the effect of software error shall either prohibit the system from assuming or maintaining an unsafe state, or shall cause the system to assume a state known to be safe” (16). According to Part 3.1.10 of the AREMA Communications & Signals Manual (2), the highway-rail grade crossing warning control system, including the preemption function, is designed as a fail-safe system and is operated as such. Therefore, any failure would result in a continuous preemption of the traffic signal controller, without a train present, until the problem is diagnosed and equipment repaired.

Augmenting or “overlying” the fail-safe simultaneous preempt provided by the railroad grade crossing warning control system with a non-vital advance preemption system provided by non-railroad equipment will achieve two objectives:

- It will not compromise the safety-critical function of moving vehicles out of the way of the train and
- It will serve the non safety-critical functions of providing full pedestrian clearance times and avoiding gates descending on stationary or slow-moving vehicles.

NON-RAILROAD TRAIN DETECTION

Critical to the concept of implementing an “overlay” non-vital advance preemption system is the ability to detect a train far enough away on its approach to the crossing, and the ability to accurately predict the arrival time of the train at the crossing. At this time it is generally not feasible to obtain train presence and predicted arrival time information from railroad equipment for a number of reasons:

- Railroad sensing equipment may not be located far enough away from the crossing to provide the required warning times.
- Technical infeasibility to share information between railroad and highway equipment.
- Reluctance of railroads to share the information, for liability or whatever other reasons.

Consequently, non-railroad train detection systems have been evaluated and deployed in research applications to detect trains and/or predict arrival times at crossings. Examples include:

- San Antonio’s Advance Warning to Avoid Railroad Delays (AWARD) train detection system uses acoustic and Doppler radar sensors on poles in city or State rights-of-way along the railroad tracks to detect the presence, speed, and length of trains prior to their arrival at grade crossings close to freeway exits. The Southwest Research Institute developed the AWARD system project as part of San Antonio’s Metropolitan Model Deployment Initiative. The project aimed to address intermodal traffic problems by providing advance information on train crossings to operators at the TxDOT TransGuide Control Center, emergency service providers, and travelers (8).

- The Texas Transportation Institute's (TTI) TransLink® Doppler Radar Train Detection System is installed in College Station, Sugar Land, and Laredo, Texas. This system uses radio-frequency Doppler radar to detect trains and continuously measure train speed while the train is in front of the detector. The Doppler system has a long detection range, allowing the system to be installed alongside the railroad tracks but outside the railroad right-of-way. The system provides the estimated time of arrival (ETA) and estimated time of departure (ETD) for each grade crossing (9,17).
- The Moorhead Area Integrated Train Detection and Traffic Control System Project uses video-based train detection. The train detection component utilizes the Autoscope Solo™ video-based sensor to detect the presence, speed, length and direction of trains (18). The sensors are mounted on a bridge over the rail line. For this project the sensors were modified for optimal train detection performance by the developer of the Autoscope system, Image Sensing Systems. This project also evaluated various detector technologies shown in Table 1. Please note that Table 1 does not appear to include installation and communication costs, and also note that prices of radar detectors have decreased significantly since the time of the study (10).
- EVA Signal Corporation's Magnetometer-based Wireless Off-Track Train Detection System uses the magnetometer design principle to sense changes in the earth's magnetic field caused by the mass of iron in the train's structure. A series of sensor probes is buried in the railroad right-of-way beside the ballast. These sensors are used to confirm the presence of a train, and train speed is measured through a speed trap sensor configuration (19,20).

Table 1. Sensor Technologies Evaluated in the Moorhead Area Integrated Train Detection and Traffic Control System Project.

Technology	Speed Capability	SideFire Capability	Bi-directional Capability	Cost per Sensor	Sensors per Site	Total Cost
Passive Infrared (PIR)	Varies	Yes	Varies	\$1,000	2	\$2,000
Pulse Ultrasonic	Yes (Paired)	Yes	Both	\$1,200	4	\$4,800
Magnetic	Yes (Paired)	Yes	Both	\$800	4	\$3,200
Doppler Microwave	Yes	Yes	Both	\$800	2	\$1,600
Video	Yes	Yes	Both	\$8,000	1	\$8,000
Passive Acoustic	Yes	Yes	Both	\$2,500	2	\$5,000
Active Infrared	Yes	Yes	Both	\$6,500	2	\$6,500
Radar	Yes	Yes	Both	\$3,300*	2	\$6,600
Radar/PIR	Yes	Yes	Oncoming only	\$2,400	2	\$4,800

* Radar sensor cost is now approximately \$700 each.

Section 8D.06 of the MUTCD Millennium Edition states “train detection circuits, insofar as practical, shall be designed on the fail-safe principle (I).” By definition, however, non-railroad train detection for non-vital advance preemption is not part of a vital, safety- critical function, and is therefore not required to be designed according to the fail-safe principle. This condition provides some leeway in determining the most appropriate failure mode under various conditions, allowing for “fail-smart” operation.

CHAPTER 2: NON-VITAL ADVANCE PREEMPTION SYSTEMS

The objective of any non-vital advance preemption (NVAP) system should be to address non safety-critical functionality, since the simultaneous preempt supplied by the railroad can always be expected to provide safety-critical functionality.

At some time after the non-railroad train detection system, detects a train the NVAP system should be activated. Ideally, the activation should take place when the train is a specific, predetermined travel time away from the crossing to ensure the optimal operation of the NVAP function or algorithm. This is analogous the relatively constant warning time provided by the constant warning time (CWT) railroad grade crossing warning control system. However, research has shown that due to train handling (train acceleration or deceleration on the approach to the crossing) and measurement and calibration errors, estimated warning times are not constant but rather significantly variable, and the variability increases as the estimated warning time increases, as shown schematically in [Figure 1 \(21,22\)](#).

Railroads address the warning time variability in simultaneous preemption through the provision of a so-called Buffer Time (BT) to ensure that the minimum warning time is provided. However, the upper limit of the warning time is not safety-critical, and therefore not controlled by the railroad. Any NVAP system should therefore be able to handle longer-than-expected simultaneous preemption warning times; in other words, the case where the simultaneous preempt sequence starts earlier than anticipated. Therefore, the threshold time at which the NVAP function or algorithm is activated should be chosen carefully—taking into account the variability in estimated warning time—to ensure that the NVAP functions for an adequate time before the start of the simultaneous preempt.

To ensure that vehicles and pedestrians receive the full benefit of the NVAP, any NVAP function or algorithm has to be implemented through the highway traffic signal controller which controls the vehicle and pedestrian signal indications. Until the time that NVAP algorithms can be implemented directly in the traffic signal controller itself, external controller inputs, as defined by the various controller specifications, has to be manipulated to implement the NVAP function or algorithm ([23,24,25](#)). The manipulation

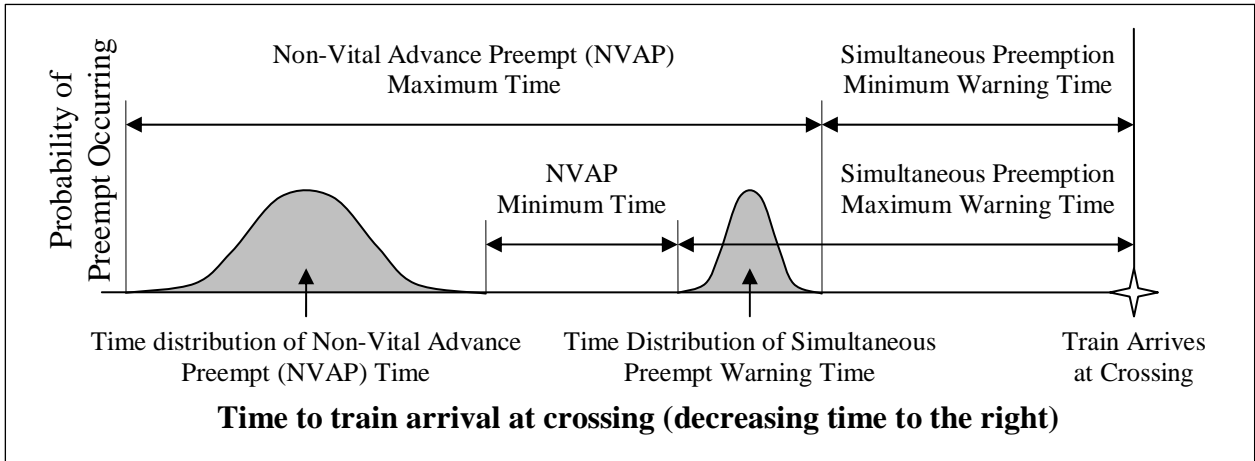

Figure 1. Variability in Expected Warning Time.

required will depend on the level of sophistication of the function or algorithm, and could vary from a simple contact closure through a relay to a time-dependent manipulation of multiple controller inputs through an external “black box.” More sophisticated algorithms are also expected to consider the current state of the traffic controller, which researchers can obtain by monitoring various standard controller outputs.

NVAP functions and algorithms in this research can be divided into two classes, and generally described as follows.

Type 1 NVAP functions activate a second, lower-priority preempt sequence in the traffic signal controller to “prepare” the controller and intersection for the impending simultaneous preempt. The simultaneous preempt has a higher priority than the preceding lower-priority NVAP sequence and overrides it. This results in functionality approximately similar to the two-preempt system currently used by the Oregon Department of Transportation that uses an advance preempt pedestrian clear-out interval (PCOI) before the simultaneous preempt vehicle clear-out interval (VCOI) to minimize the occurrence of abbreviated pedestrian clearance intervals (26).

Type 2 NVAP functions activate one or more non-preempt inputs to prepare the controller and intersection for the impending simultaneous preempt. Type 2 NVAP functions can be implemented through special wiring on the controller assembly (cabinet) back panel. Potential functionality includes:

- omitting the activation of any new pedestrian phases to keep pedestrian phases from being serviced (and potentially truncated) as the train approaches the crossing,
- activating the track clearance phase or another phase early to ensure that stationary vehicles start moving prior to the preempt,
- placing the controller into free (non-coordinated) mode to be more responsive to the traffic demand prior to the simultaneous preempt, and
- combinations of these or other functions.

NON-VITAL ADVANCE PREEMPTION STRATEGY – TYPE 1

The primary objective of this strategy is to provide the full amount of pedestrian clearance on the phase being terminated by the train preempt. [Figure 2](#) shows the typical signal phase sequencing that occurs under simultaneous preemption. Under simultaneous preemption, the traffic signal controller is permitted to truncate and even skip the pedestrian clearance phase in order to transition to the track clearance phase. NVAP – Type 1 attempts to address this situation by using a lower-level preempt to accomplish the following objectives to:

- safely clear the currently active phase in the controller,
- provide standard pedestrian clearance time for the phase(s) that parallel the railroad tracks, and
- transition to and dwell in the track clearance phase(s) until the controller receives a call for simultaneous preemption.

To achieve these objectives the NVAP – Type 1 system will compare the estimated arrival time of the train to the required advance notification time needed at the crossing. As shown in

[Figure 3](#), the required advance notification time is the sum of the following time elements in the controller:

- the pedestrian clearance interval associated with the currently active phase,
- the “YELLOW” and “ALL-RED” clearance intervals associated with the currently active phase,

- the pedestrian “WALK” and clearance intervals associated with the phase(s) running parallel to the railroad tracks, and
- the “YELLOW” and “ALL-RED” clearance intervals associated with the phase(s) running parallel to the railroad track, and
- a buffer time defining how long the controller should be dwelling in the track clearance phase prior to the activating of the higher-level preempt.

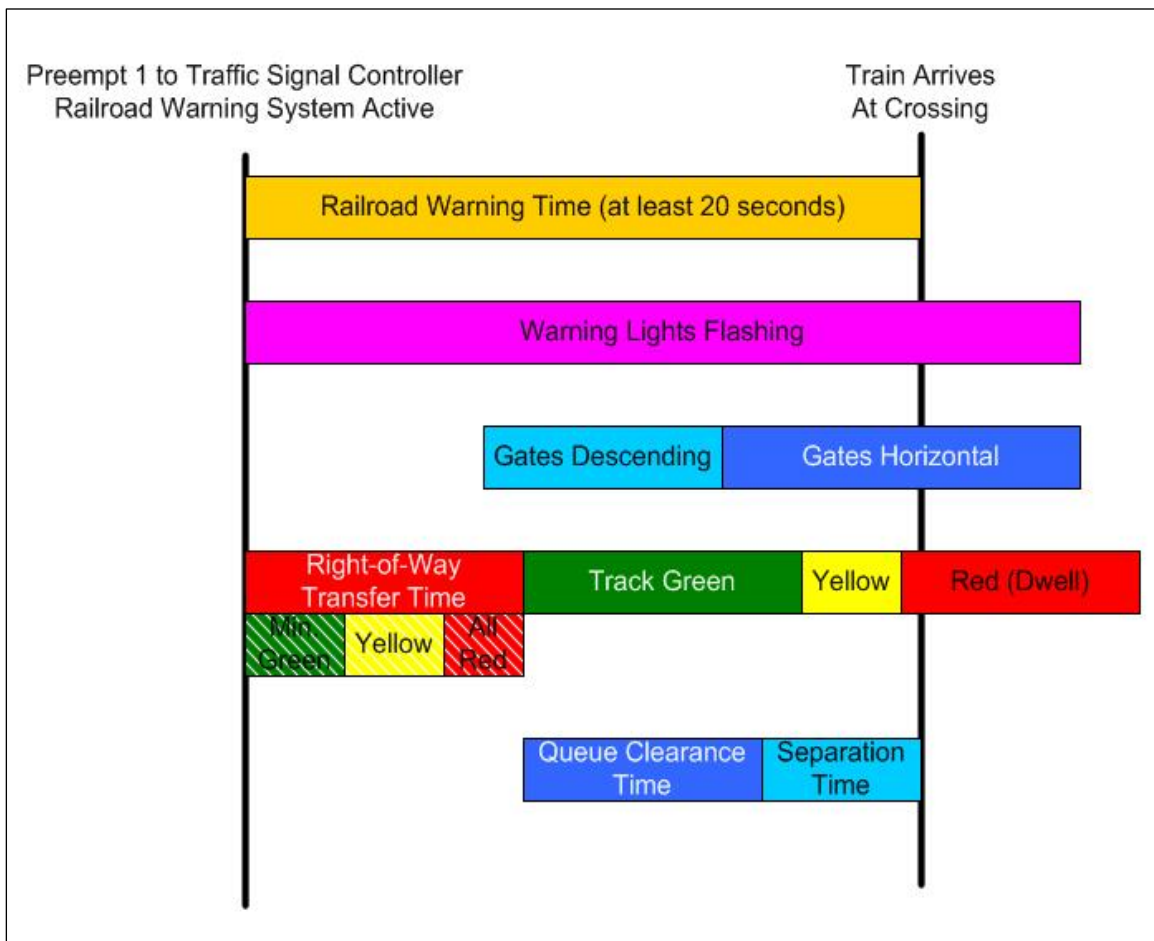

Figure 2. Signal Phase Sequence under Simultaneous Preemption.

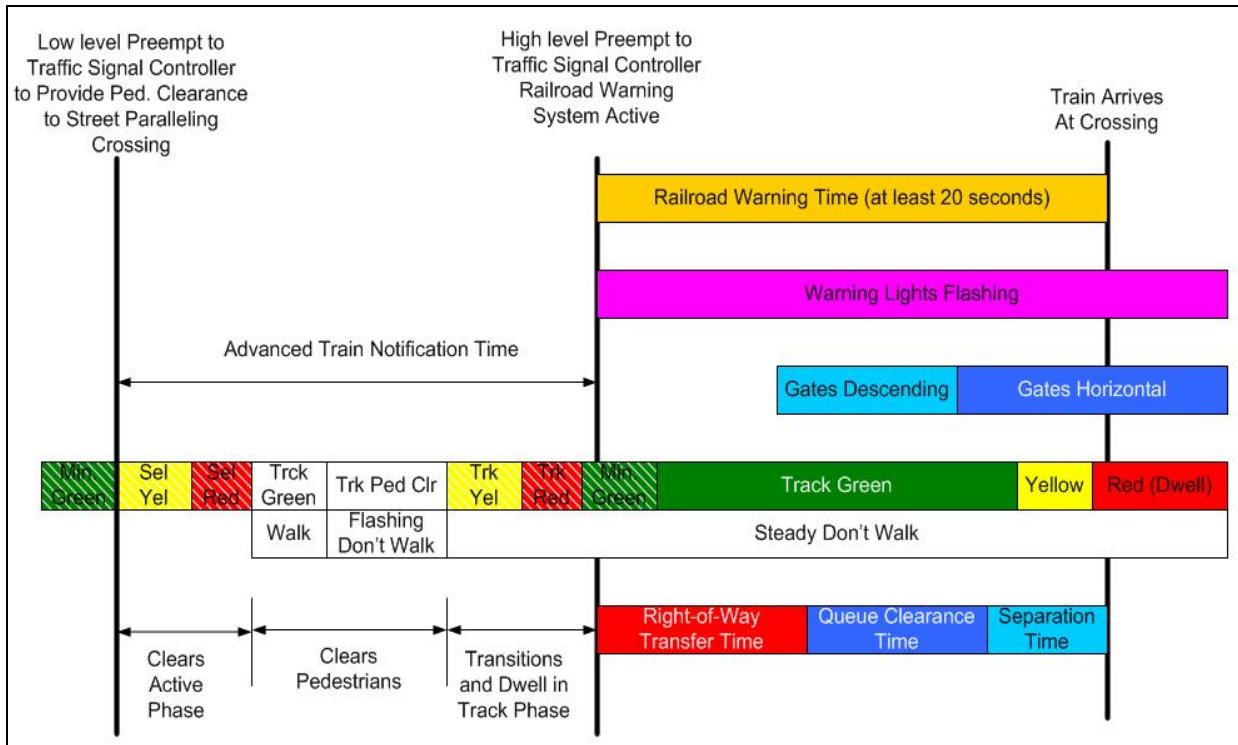

Figure 3. Identification of the Activation Point for the NVAP – Type 1 Algorithm.

The basic operation of the NVAP – Type 1 algorithm works as follows. When no trains are in the corridor, NVAP – Type 1 is in a resting state. The NVAP – Type 1 becomes active when it receives an estimate of the arrival time of the train to the grade crossing. The NVAP – Type 1 then compares the estimated train arrival time to the programmed “Advance Train Notification Time.” The “Advance Train Notification Time” is computed as the sum of values of the following input parameters entered by the user:

- Preempt Min. Green/Walk,
- Selective Pedestrian Clear,
- Selective Yellow Change,
- Selective Red Clear,
- Track Green,
- Track Pedestrian Clear,
- Track Yellow Change,
- Track Red Clear, and
- Preempt Separator,

The preempt separator is a parameter set by the user as a buffer between the end of the preempt transition time and the beginning of the Phase 1 preempt.

If the NVAP– Type 1 algorithm determines that the estimated arrival time of the train is less than or equal to the required advance notification time, then the NVAP system will activate the programmed lower-level preempt. The NVAP system will keep the lower-level preempt activated until it detects that the normal preempt associated with the grade crossing has been activated. Once the normal preempt has been activated, the NVAP system will deactivate the lower-level preempt and then return normal operations.

Figure 4 is a functional flow diagram depicting the operations of the NVAP – Type 1 algorithm, while Figure 5 depicts the data flows between the major subsystems used in NVAP – Type 1.

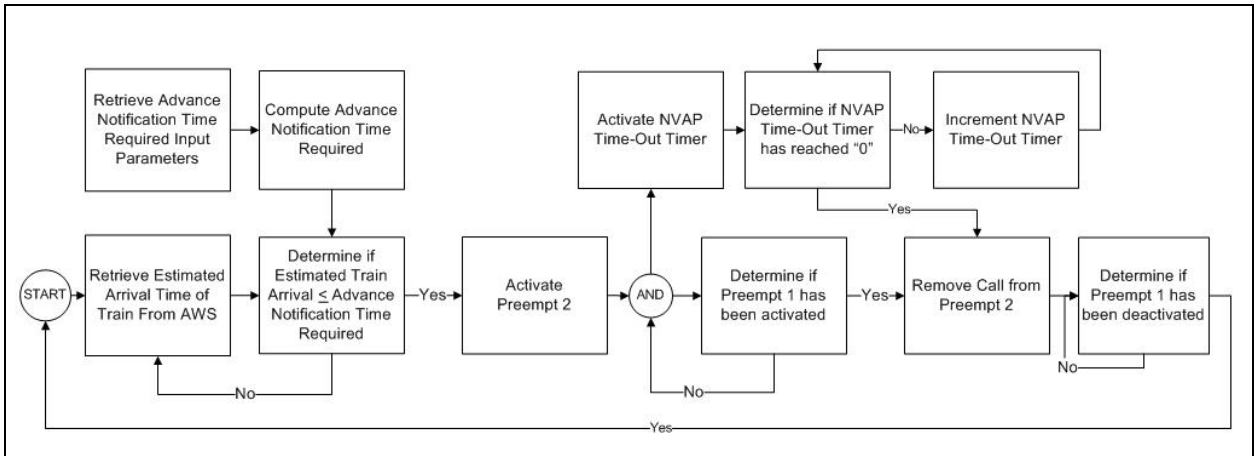

Figure 4. Functional Flow Diagram Depicting the Operations of NVAP – Type 1.

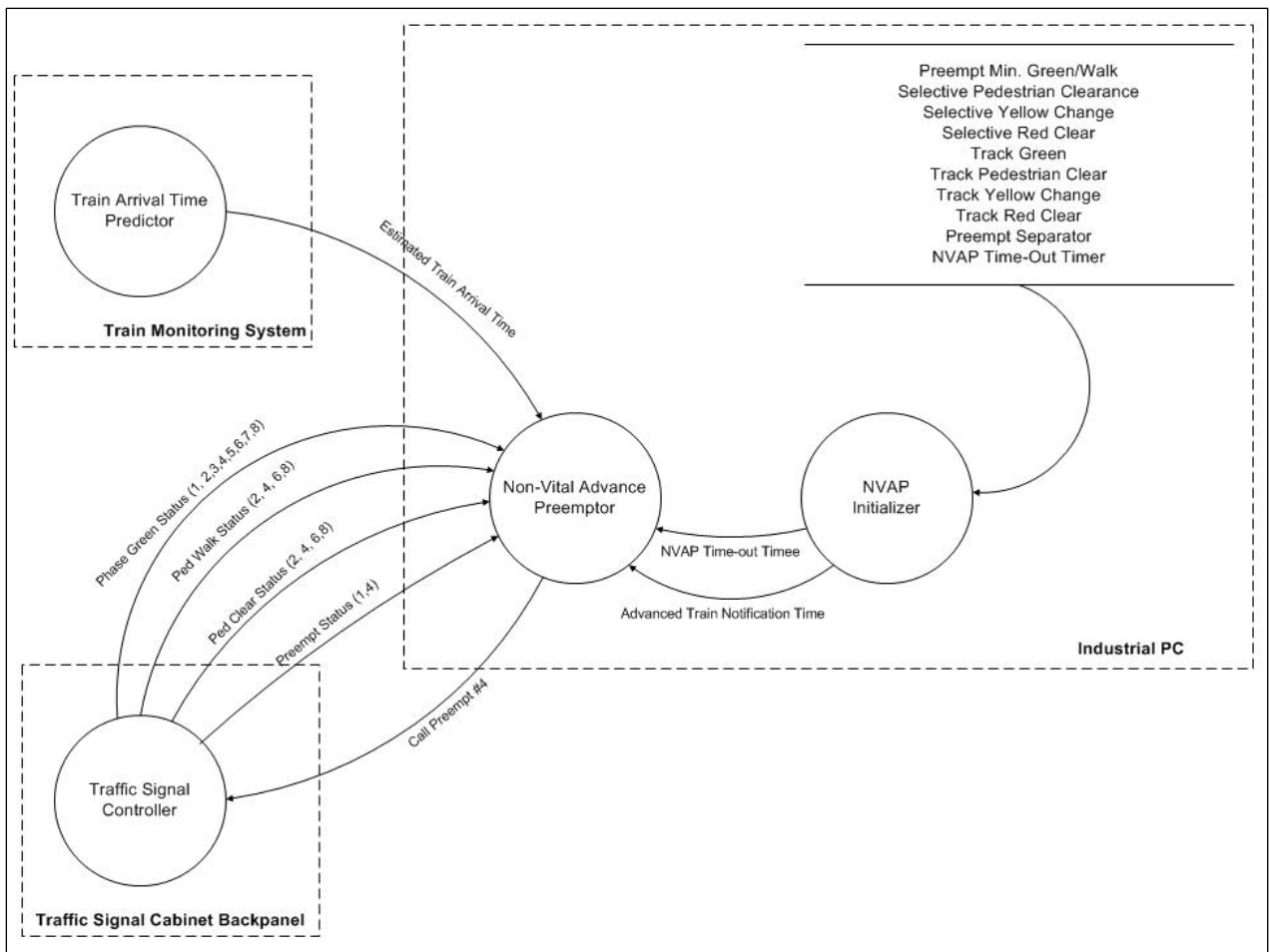

Figure 5. Data Flow Diagram for NVAP – Type 1.

NON-VITAL ADVANCE PREEMPTION STRATEGY – TYPE 2

With NVAP – Type 1, the control objective is to ensure that if a pedestrian phase has been activated, a full pedestrian clearance interval is always provided when transitioning in to preemption for the train. With NVAP – Type 2 the control philosophy is fundamentally different. With NVAP – Type 2, we are using the Pedestrian Omit (PED OMIT) feature of the control to keep from activating the pedestrian phase if there is not enough time to provide the full pedestrian phase requirements (WALK plus flashing DON'T WALK) before the preempt is activated.

Figure 6 illustrates the situation where there is sufficient time to fully service the entire pedestrian “WALK” and pedestrian change interval before the controller receives a preempt call. In this situation, the preempt call would not create the need for the pedestrian “WALK” or pedestrian change interval to be shortened. As a result, the NVAP system should allow the controller to activate the pedestrian phase.

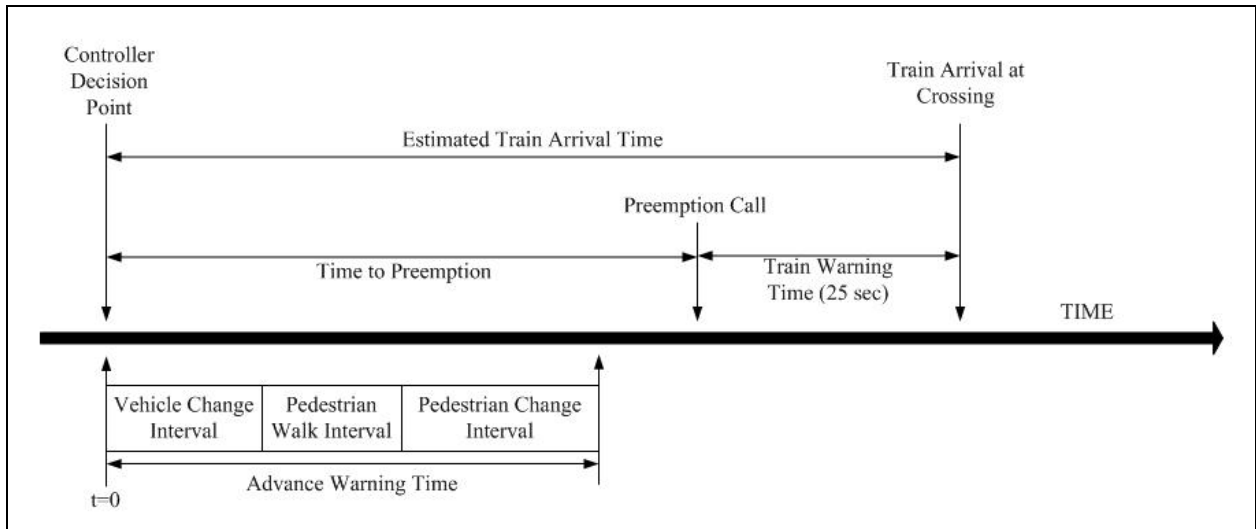

Figure 6. Scenario Where Pedestrian Interval Can Be Fully Serviced Prior to Preemption Call.

Figure 7 shows a scenario where at the time the controller makes its decision as to which phase to service next, insufficient time exists for pedestrian clearance interval to be fully serviced before preemption occurs.

Under simultaneous preemption, the controller would need to shorten the pedestrian clearance interval in order to clear the grade crossing before the train arrived. In this case, it would be better not to allow the controller to activate the pedestrian walk interval at all and, instead, leave the pedestrian signals with a solid “DON’T WALK” indication.

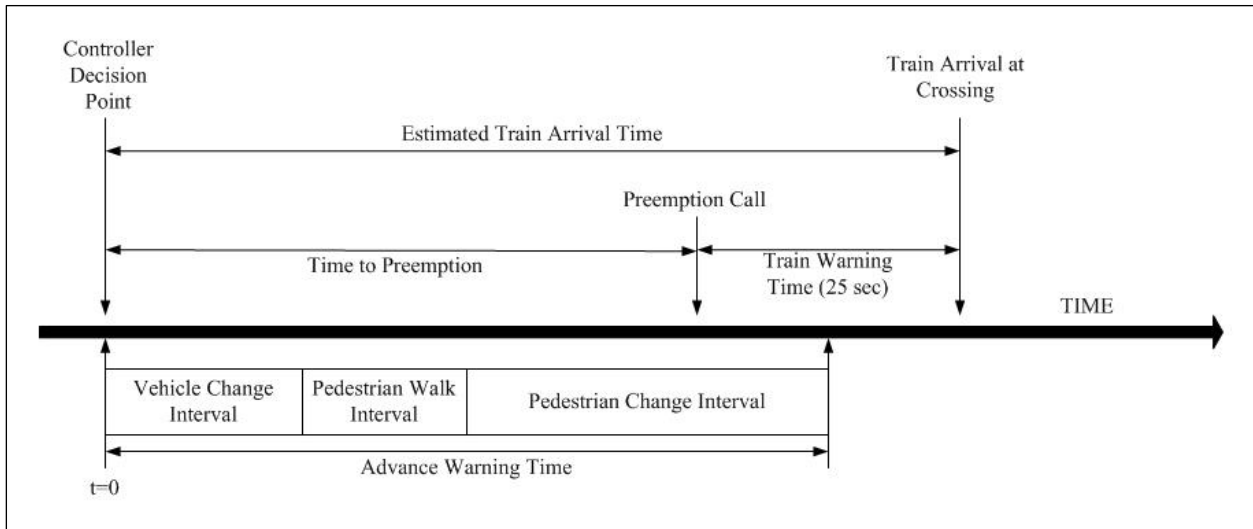

Figure 7. Scenario Where Pedestrian Interval Cannot Be Fully Serviced Prior to Preemption Call.

NVAP – Type 2 seeks to prevent the need for shortening these intervals by not allowing the controller to activate the pedestrian interval if there is not sufficient time to fully service both the pedestrian walk and pedestrian change intervals.

Concept of Operations

With this strategy, the NVAP – Type 2 controller would be installed in a traffic signal cabinet in the field. The NVAP controller would be connected to the traffic signal controller (either serially or through the controller cabinet back panel). The NVAP – Type 2 controller would also be connected to a rail monitoring system. The rail monitoring system would provide estimates of the arrival time and departure time of the train at the grade crossing. By specification, control decisions as to which phase to service next in a timing sequence are made at the end of the GREEN interval of the terminating phase in National Electrical Manufacturers Association (NEMA) traffic signal controllers.¹ The NVAP system would monitor the status of the traffic signal controller and the grade crossing and determine when the controller was at a control decision point and if there was a train in the corridor. Each time the traffic signal

¹ Unless the decision cannot be made at the end of the GREEN interval, it shall not be made until after the end of all VEHICLE CHANGE and CLEARANCE intervals.

controller is at its control decision point, the NVAP system would retrieve the expected arrival time of the train at the crossing and use it to compute the estimated time-to-preemption. The NVAP system would then compare the estimated time-to-preemption to the time needed to fully service the pedestrian interval for the next corresponding phase to determine if there is adequate time to allow the full pedestrian interval to be serviced before the train triggers a simultaneous preempt call to the controller. If the NVAP system determines there is enough time to fully service the entire pedestrian phase before the controller receives a preempt call, then the NVAP system shall allow the controller to operate as normal. If, on the other hand, the NVAP system determines that there is not enough time to fully service the mandatory vehicle change interval plus the pedestrian walk and pedestrian clearance intervals of next phases before the controller receives a preempt call, then the NVAP system will send a “Pedestrian Omit” (PED OMIT) command to the controller. The PED OMIT will keep the controller from activating the pedestrian phase, causing the pedestrian indication to remain in a steady “DON’T WALK” state, thereby eliminating the possibility of having to truncate the pedestrian clearance interval when the train arrives at the crossing. [Figure 8](#) shows a top-level functional diagram of the NVAP –Type 2 control algorithm while [Figure 9](#) shows how data flows between the major functional elements in the NVAP – Type 2 algorithm.

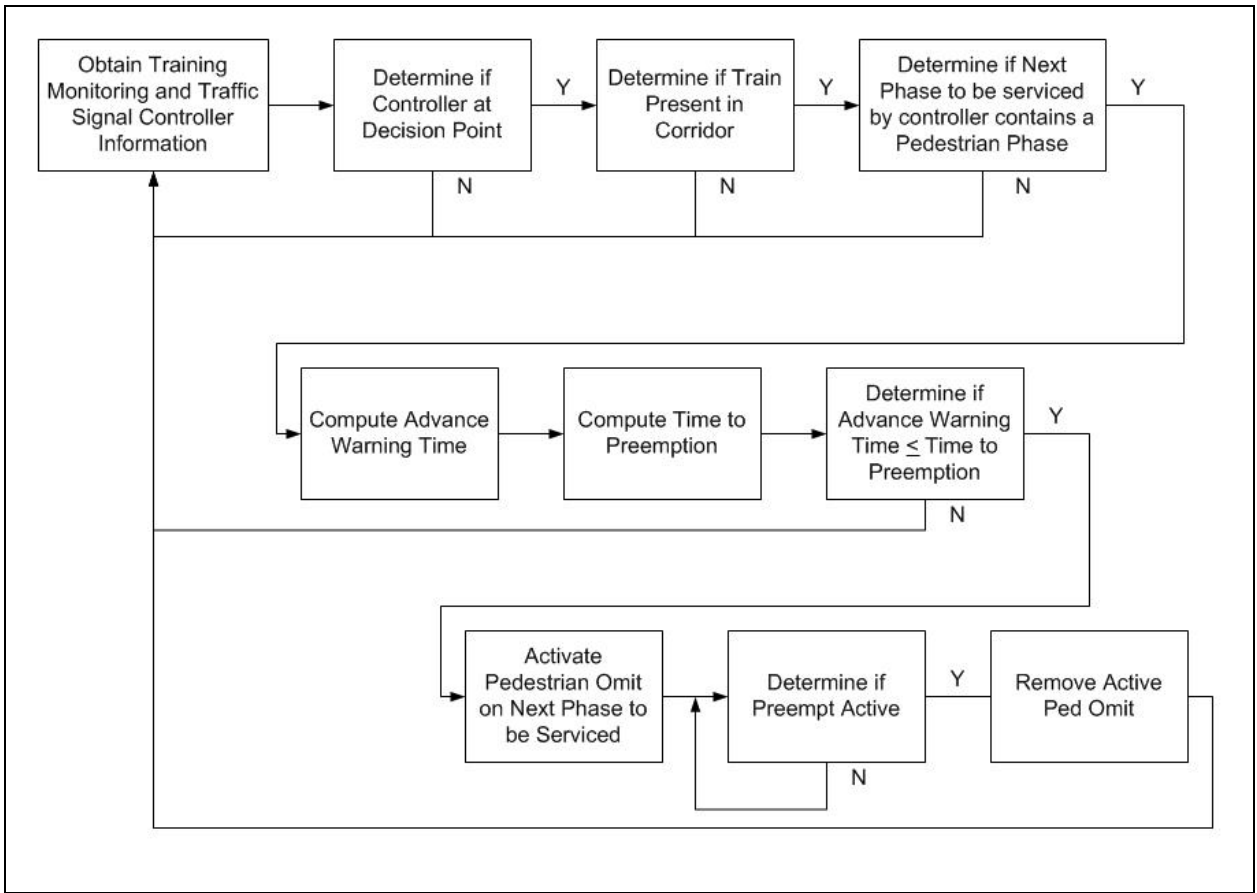

Figure 8. Top-Level Functional Diagram of NVAP – Type 2 Control Strategy.

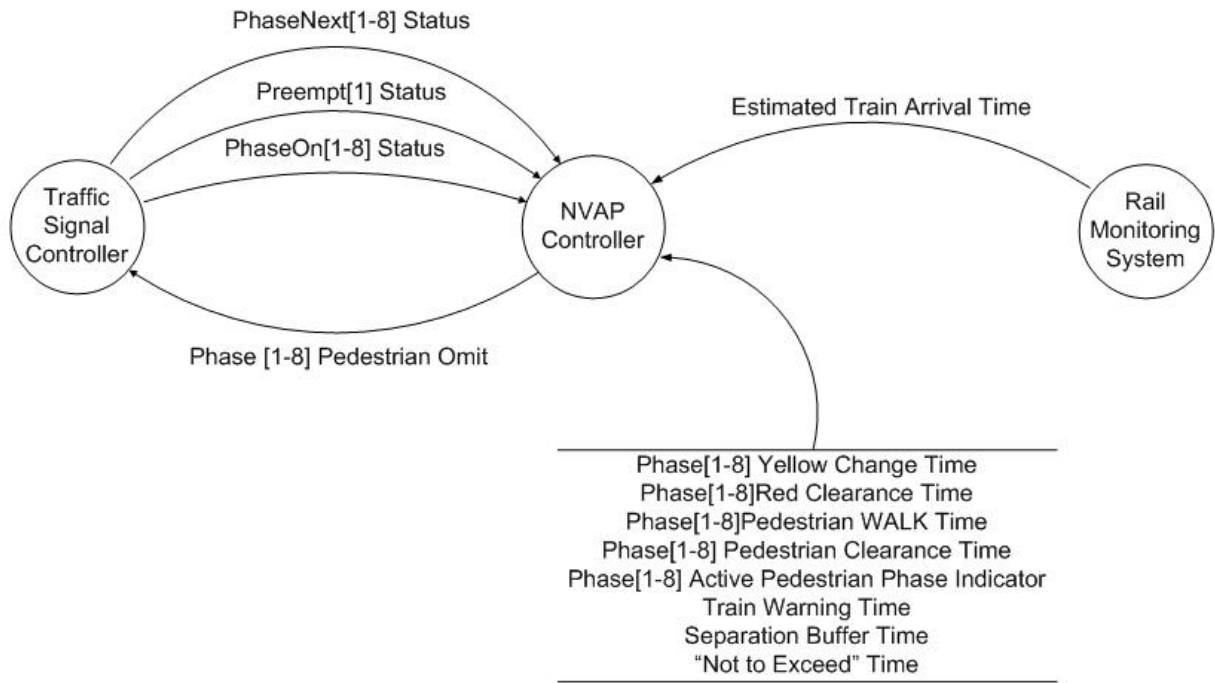

Figure 9. Data Flow between Functional Elements in the NVAP –Type 2 Algorithm.

Determining if Controller is at Decision Point

Because a PED OMIT command will not cause the controller to take effect once a phase has started, it is critical that the NVAP system issues the PED OMIT command prior to the pedestrian phase becoming active. NEMA traffic signal controllers produce an output called the PHASE NEXT that indicates when the controller has made its decision as to what phase it is going to service next in the sequence. Unless there is a peculiar reason, the PHASE NEXT output is energized at the end of the GREEN interval of the terminating phase and remains in this state until the corresponding phase becomes active. This output can be used as a trigger for the NVAP system to check to see if the PED OMIT command should be activated.

Each phase that is active in the controller has its own PHASE NEXT Output. [Table 2](#) shows the pin locations and connectors that correspond to each respective phase in the controller. This system shall check the state of each output at least once every 10 milliseconds. If the NVAP system detects that one or more of the PHASE NEXT outputs has changed its state from “OFF” to “ON” (i.e., become energized) signaling that the controller is getting ready to change phases, the NVAP system should record the phase number(s) which the controller services next and then proceed with determining if the next phase is one that contains a pedestrian interval. If the NVAP system does not detect a change in the state of the PHASE NEXT output, it should continue monitoring each of the PHASE NEXT outputs until one or more changes states.

Table 2. Connector and Pin Locations of the “Phase Next” Outputs in a TS 1 Controller.

Controller Function	Connector-Pin Location^a
Phase 1 Phase Next	B-A
Phase 2 Phase Next	B-C
Phase 3 Phase Next	B-t
Phase 4 Phase Next	B-f
Phase 5 Phase Next	C-M
Phase 6 Phase Next	C-DD
Phase 7 Phase Next	C-PP
Phase 8 Phase Next	C-HH

^aThese pin locations are based on ABC Output Mode “0”. These pin locations may vary if another ABC Output Mode is used in the controller.

Determining if Next Phase To Be Serviced Has Pedestrian Interval

Not every phase has a pedestrian interval associated with it. For example, pedestrian intervals are associated with phases that service through vehicle movements and not left-turn phases. The standard NEMA phase numbering scheme generally assigns even numbers (i.e., 2, 4, 6, and 8) to the through movement phases, and odd

numbers (i.e., 1, 3, 5, and 7) to the left-turn phases. But because not every jurisdiction or intersection uses the same numbering scheme to describe their phasing patterns, it would be imprudent to assume that pedestrian intervals are automatically associated with only the even number phases. Therefore, we require that the user, through an initial setup screen discussed previously, identify the vehicle phases to which pedestrian phases are associated. Once the NVAP system detects 1) that a train is present in the corridor, and 2) that the controller is at a control decision point, the NVAP system shall determine if the vehicle phase that is going to be serviced next is one that is also associated with a pedestrian phase. This can be done with comparing the number(s) of the phase associated with the energized PHASE NEXT output(s) to the associated vehicle/pedestrian phase flags set in the initialization screen. If the phase number flags agree with one another (e.g., are equal), then the NVAP system should proceed with determining if there is enough time to fully service the pedestrian interval before a train triggers a simultaneous preemption call. If the phase number flags do not agree, then the NVAP system can assume that there is no pedestrian phase associated with the phase that it is about to become active. When this occurs, the NVAP system should return to the ready state and continue monitoring the PHASE NEXT outputs until the previous condition is met.

Determining If There Is Sufficient Time to Service Pedestrian Interval

Once the NVAP system has determined 1) there is a train in the corridor approaching the intersection, 2) the controller has reached a control decision point, and 3) the phase to be serviced next by the controller has an associated pedestrian interval, the NVAP system must then determine if there is sufficient time to fully service the pedestrian interval or if phase will be truncated because of a preemption call. In order to make this decision, the NVAP system must determine the following:

- the estimated time to preemption and
- the required advance warning time.

Figure 10 provides an illustration of these two parameters.

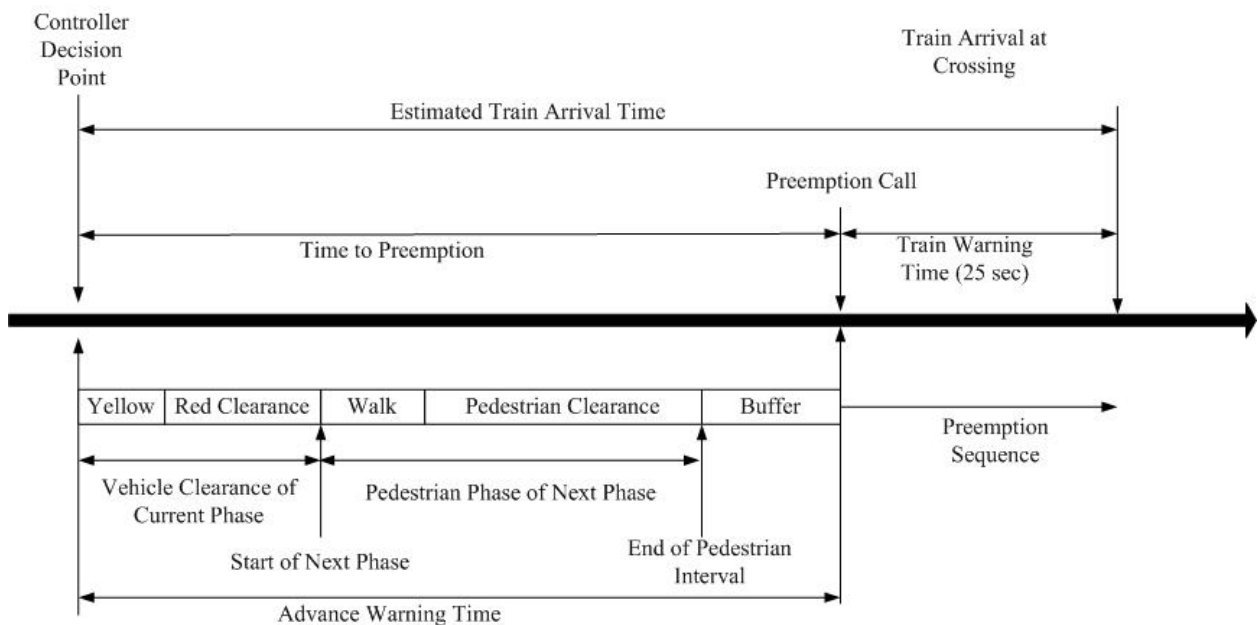

Figure 10. Illustration of Time to Preemption and Required Advance Warning Time in NVAP – Type 2.

The estimated time to preemption is defined as the time interval that will elapse between the control decision point and when the preempt call is expected to come into the controller. For simultaneous preemption systems, it can be estimated by computing

the estimated arrival time minus the usual train warning time. When the NVAP system determines that the signal controller is at a control decision point, the NVAP system shall retrieve the current estimated train arrival time from the rail monitoring system. This is a real-time value that is continuously updated as the train progresses through the corridor. The user sets the value of the train warning time parameter in the initialization screen. By law, the minimum train warning time is 20 seconds, but at many crossings in Texas, the value parameter is generally 25 seconds (providing a 5-second cushion above the minimum required). The NVAP system allows the user to enter any value greater than 20 seconds with a default value of 25 seconds. The NVAP system shall not allow the user to enter a value less than 20 seconds. The advance warning time is the sum of the following traffic signal timing parameters:

- The yellow and all-red vehicle change intervals associated with the current phase that is being cleared.
- The pedestrian walk and pedestrian change interval associated with the next phase that the controller will service.
- A buffer interval that the user can set to provide additional time separation to account for errors in estimating train arrival times.

If deployed with a National Transportation Communications for ITS Protocol (NTCIP) compatible controller, the NVAP system could be configured to get all of these parameters (except for the buffer interval) directly from the traffic signal controller. However, for this project, it is assumed that the NVAP system will be deployed with a NEMA Traffic Control Systems (TS) 1 or NMEA TS 2 compatible controller. In this case, the NVAP system would need to retrieve the value of these parameters from an initialization file. The value of these interval timings should reflect exactly what has been programmed into the traffic signal controller for each phase.

Issuing A Pedestrian Omit (PED OMIT) Command

Once the value of the advance warning time and the time-to-preemption parameters has been computed, the NVAP system shall compare the two parameters to

determine if there is sufficient time to service the pedestrian interval. The logic for making this determination is as follows:

- If the advance warning time parameter is less than or equal to the time to preemption, then the controller should have sufficient time to service the pedestrian interval before the controller receives the preempt call. If this is the case, then the NVAP system should NOT energize the PED OMIT controller input (e.g., keep the PED OMIT in the “OFF” state) associated with the phase to be serviced next. The PED OMIT controller input should remain in this state until the next control decision point.
- If, on the other hand, the advance warning time is greater than the time to preemption, then there is not sufficient time to fully service the pedestrian interval before the controller receives the preempt call. When this situation is true, the NVAP system shall energize the PED OMIT associated with the phase, causing the state of the PED OMIT to become “ON.” This action will cause the controller to keep the pedestrian interval from timing and remain in the solid “DON’T WALK” state.

Immediately upon issuing a PED OMIT command, the NVAP system should initiate a “Not to Exceed” timer that will cause the PED OMIT to be lifted if a preempt call is never detected by the system. This “Not to Exceed” timer shall be a countdown time, starting with an initial value equal to that set by the user upon initialization of the system. The “Not to Exceed” timer shall be reduced by a value of one for each second after the PED OMIT is issued.

Deactivating the PED OMIT Command

Once the NVAP system has issued the PED OMIT phase, the PED OMIT should remain in the energized (or “ON”) state until at least one of the following conditions has been met:

- The NVAP system detects that the traffic signal controller has received a preempt call associated with grade crossing (usually Preempt 1).

- The NVAP system detects the controller has progressed to its next control decision (i.e., the PHASE NEXT output for another phase in the same controller ring has been activated) without a preempt call being issued to the controller.
- The NVAP system detects that the “Not to Exceed” timer has reached a value of zero.

If any one of the conditions occurs, the NVAP system shall deactivate the PED OMIT command (i.e., change that state of the PED OMIT pin to “OFF”). Once the PED OMIT call has been lifted, the NVAP system should re-initialize timers and parameters to their initial values and return to its initial state.

CHAPTER 3: SIMULATION STUDY OF NON-VITAL ADVANCE PREEMPTION

Before implementing the NVAP – Type 1 and NVAP – Type 2 in the field, we conducted simulation studies to identify any potential problems and to assess their potential effectiveness prior to installation. These simulation studies were conducted in the TransLink[®] Research Center laboratory using hardware-in-the-loop simulation. The following describe the results of these simulation studies.

TREATMENTS

Simultaneous Preemption

Simultaneous preemption represents the current state-of-the-practice used at most highway-rail grade crossings. Under simultaneous preemption, notification of an approaching train is forwarded to the highway traffic signal controller unit or assembly and railroad active warning devices at the same time (1, 2). Simultaneous preemption is typically used where the minimum warning time needed for the operation of the railroad active warning devices (flashing lights and gates) is sufficiently long to clear stationary vehicles safely out of the crossing. By law (3), railroad companies are required to provide traffic agencies with at least 20 seconds advance warning of the train's impending arrival at the grade crossing. However, most railroads try to provide traffic agencies with approximately 25 seconds advance warning for simultaneous preemption. Additional warning time (i.e., more than the required 20 seconds) can be requested from the railroad to provide advance preemption; however, because of costs, this is not done at most highway-grade crossings. Therefore, we used simultaneous preemption as the basis of comparison for the simulation study.

For purposes of this simulation study we have concluded, based on site specific measurements, that the simultaneous preemption sequence begins 25 seconds in advance of a train's arrival at the highway-grade crossing. This finding is not to be considered a standard for other locations. Each prospective site should be evaluated to determine the proper time that the preemption sequence starts ahead of train arrival .

NVAP - Type 1

Under this alternative, a second, lower-priority preempt sequence is activated in the traffic signal controller to “prepare” the controller and intersection for the impending simultaneous preempt. The simultaneous preempt has a higher priority than the preceding lower-priority NVAP sequence and overrides it. This overriding results in functionality approximately similar to the two-preempt system currently used by the Oregon Department of Transportation that uses an advance preempt pedestrian clear-out interval before the simultaneous preempt vehicle clear-out interval to minimize the occurrence of abbreviated pedestrian clearance intervals (26).

NVAP - Type 2

In this strategy, one or more non-preempt inputs is activated to prepare the controller and intersection for the impending simultaneous preempt. Type 2 NVAP functions can be implemented through special wiring on the controller assembly (cabinet) backpanel. Potential functionality includes:

- omitting the activation of any new pedestrian phases to keep pedestrian phases from being serviced (and potentially truncated) as the train approaches the crossing,
- activating the track clearance phase or another phase early to ensure that stationary vehicles start moving prior to the preempt,
- placing the controller into free (non-coordinated) mode to be more responsive the traffic demand prior to the simultaneous preempt, and
- any combination of these or other functions.

STUDY APPROACH

To compare the effectiveness of the NVAP algorithms, we used TransLink®’s Hardware-in-the-Loop Traffic Simulation system. In this system, a traffic simulation model is connected with a real traffic signal controller through a controller interface device. The traffic simulation model was programmed to provide vehicle and train

movements through an intersection. Detectors in the simulation model provide vehicle actuations to the traffic signal controller through the controller interface device. The traffic signal controller responds to the vehicle actuations and changes phase indications according to timing parameters entered in the controller, just like it would if it was running in the field. Signal phase outputs from the controller are sent back via the controller interface device so that the signal indications in the simulation model are actually controlled by the traffic signal controller.

In this study, we used VISSIM[®] Version 3.7. VISSIM[®] is a microscopic simulation model marketed by PTV America, Inc. (27). We selected VISSIM[®] because of its ability to simulate pedestrians as well as trains. For the traffic signal controller, we used an Eagle EPAC 300 Actuated Traffic Signal Controller running version 3.12 firmware. The controller was connected to the simulation model using an Eagle TS 2 Test Box. Figure 11 shows a photograph of the hardware-in-the-loop setup.

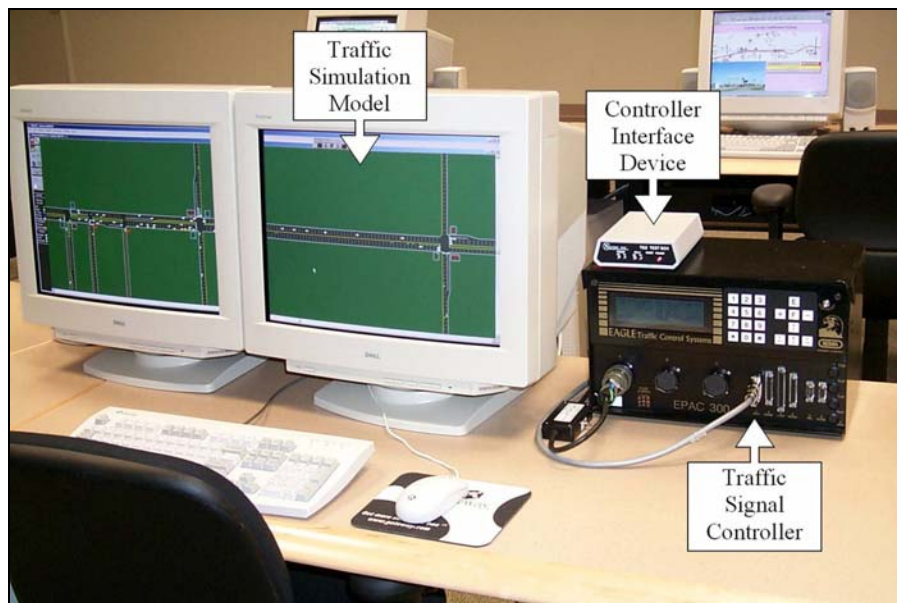

Figure 11. Example of Hardware-in-the-Loop Setup Used in the Simulation Study.

Test Intersection

The intersection used in the simulation was modeled after the George Bush Drive / Wellborn Road intersection, located in College Station, Texas. Figure 12 shows a screen capture of the intersection in the simulation model. Wellborn Road is a major north-south arterial in College Station. It has two lanes in each direction separated by a

two-way left-turn lane. George Bush Drive is a major east-west arterial that crosses the railroad tracks just to the west of the Wellborn Road intersection. At this intersection, George Bush Drive has two through lanes and a single left-turn lane. All lanes on all the approaches have been modeled as being 12 feet in width. While the actual separation between the railroad tracks and the intersection is approximately 30 feet, we have modeled the separation distance to be approximately 75 feet in order to provide a situation more commonly found throughout the state of Texas.

Figure 13 shows the traffic and pedestrian volume data that we used in the simulation. Each intersection approach, with the exception of the eastbound George Bush Drive approach, was assumed to have an approach volume of 1000 vehicles per hour with 2 percent trucks. We assumed the eastbound approach of George Bush Drive to have a traffic volume of 700 vehicles per hour with 20 percent trucks. Turning movement volumes for each approach, expressed as a percentage of the total approach volume, are also shown in Figure 13. Figure 13 also shows the minimum, mean, and maximum speeds we assumed for each vehicle type in the simulation. A uniform distribution was assumed for all vehicle speeds.

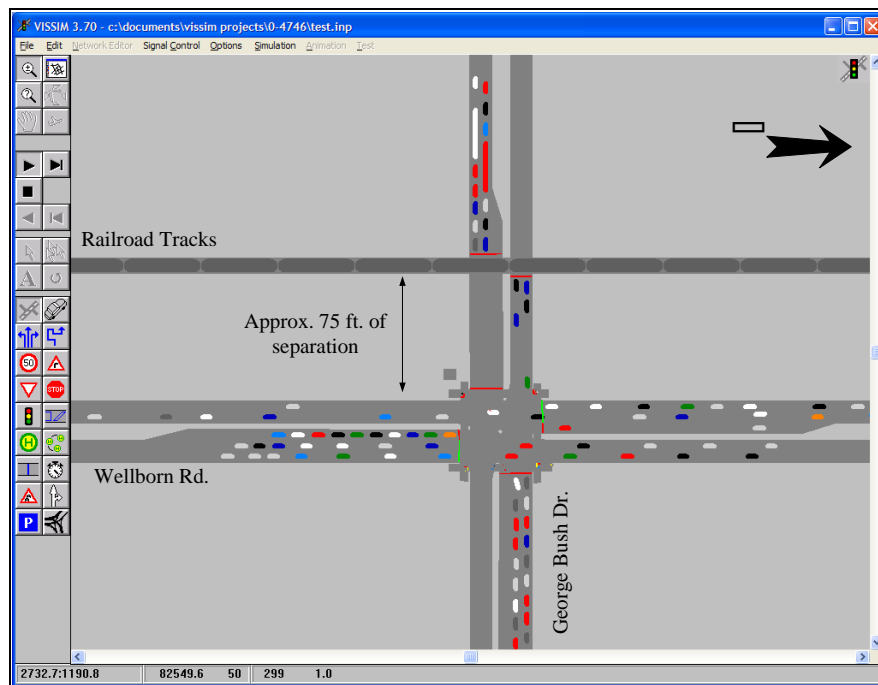

Figure 12. Screen Capture of Simulated Intersection of George Bush Drive and Wellborn Road in College Station, Texas.

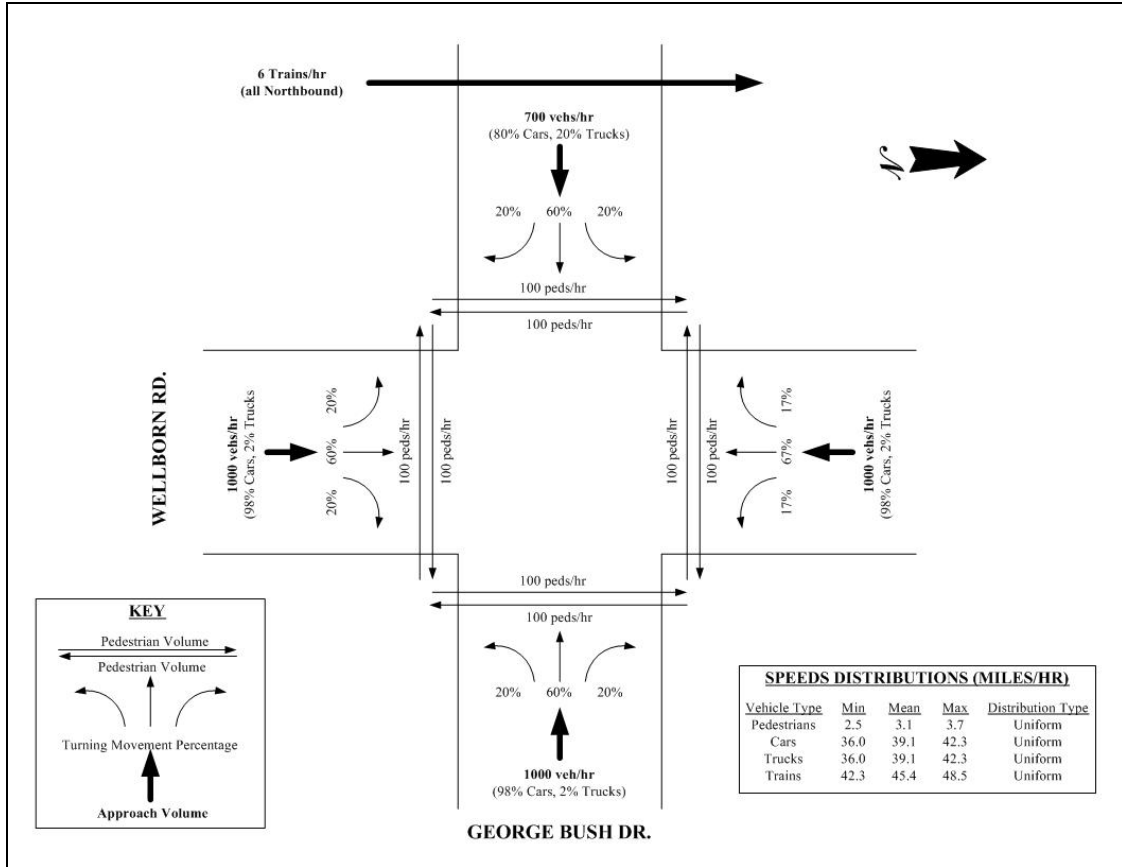

Figure 13. Volumes and Speed Parameters of Vehicles, Pedestrian, and Trains Used in Simulation Evaluation.

A separate link was provided to simulate a railroad track near the grade crossing. VISSIM has the capability of modeling train movements. For this simulation, we assumed a train volume of six trains per hour (or a headway of 10 minutes). All trains were programmed to be the same length (4387.17 ft). We used only northbound trains in this simulation.

Traffic Signal and Preemption Timing Parameters

For this study, we used an Eagle EPAC 300 actuated controller. We configured the traffic signal controller to operate the intersection in four-phase, quad-left phasing sequence. Pedestrian phases were also programmed to operate with their corresponding through movement phase. [Figure 14](#) shows the numbering scheme for each

corresponding vehicle and pedestrian phase. It also shows the phase sequencing used in normal (i.e., non-preemption) operations and during a simultaneous preemption.

We programmed the controller to operate the intersection under isolated, actuated control. We assigned virtual loop detectors in the traffic simulation model to provide detector inputs in the traffic signal controller. Each detector was programmed to operate in the presence mode. Pedestrian detectors were also used to call the pedestrian phases. [Table 3](#) shows the actuated and pedestrian signal timing parameters we used in the controller for this simulation study.

Table 3. Phase and Pedestrian Signal Timing Data for Non-Preempt Operations.

Controller Setting		NEMA Phase Number							
		1	2	3	4	5	6	7	8
Phase Timing Data	Movement Served*	NBL	SBTR	EBL	WBTR	SBL	NBTR	WBL	EBTR
	Min. Green (sec)	10	15	10	15	10	15	10	15
	Passage Time (sec/10)	10	10	10	10	10	10	10	10
	Max #1 (sec)	50	50	25	50	25	50	25	50
	Max #2 (sec)	30	50	30	50	30	50	30	50
	Yellow (sec/10)	40	40	40	40	40	40	40	40
	Red (sec/10)	10	10	10	10	10	10	10	10
Pedestrian Timing Data	Walk (sec)	0	7	0	7	0	7	0	7
	Ped. Clear (sec)	0	15	0	15	0	15	0	15
	Flashing Walk	No	No	No	No	No	No	No	No
	External Ped. Clear	No	No	No	No	No	No	No	No
		No	No	No	No	No	No	No	No

* NB= Northbound; SB=Southbound; EB=Eastbound; WB=Westbound; L=Left-turn; T=Through; R=Right-turn

Simultaneous preemption was provided in the controller through Preempt 1. We used a detector on the railroad track to place a call to Preempt 1 in the controller. The leading edge of this detector was situated upstream (or south) of the grade crossing so as to provide at least 25 seconds advance warning of a train's arrival. Each train blocked the crossing for approximately one minute, depending upon the speed of the train.

The timing parameters we used in the controller to provide both Simultaneous Preemption (using Preempt 1) and NVAP – Type 1 (using Preempt 2) are shown in [Table 4](#). [Table 5](#) shows the setting entered in the controller for each phase to achieve the desired operations during both the Preempt 1 and Preempt 2 sequence.

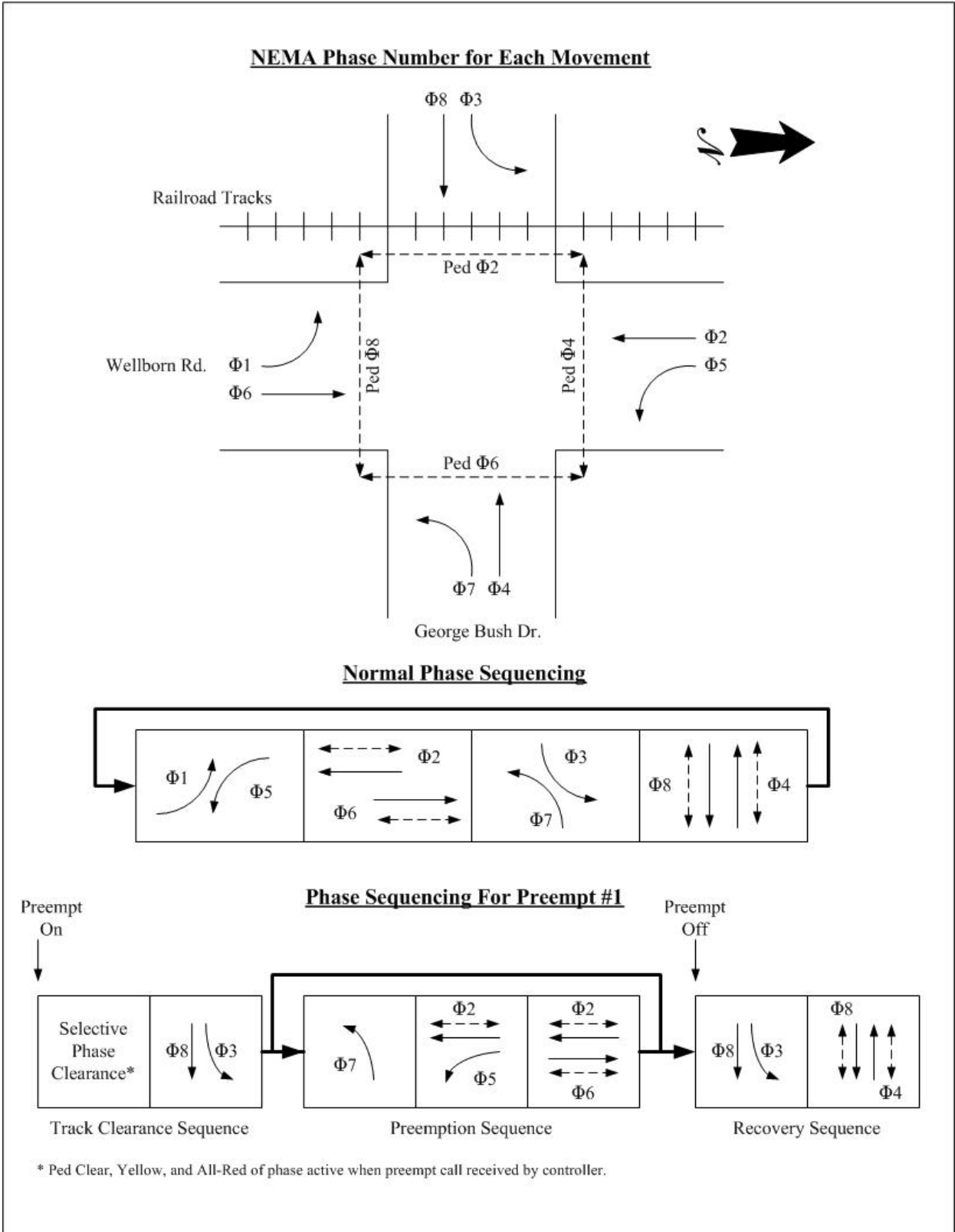

Figure 14. Phasing Sequence Diagram for Normal and Simultaneous Preemption.

Table 4. Interval Times Programmed into Preempts 1 and 2 to Provide Simultaneous and Non-Vital Preemption.

Preempt Interval Times	Preempt Number*	
	1	2
Minimum Green (sec)	5	5
Selective Pedestrian Clear (sec)	0	15
Selective Yellow Change (sec/10)	40	40
Selective Red Clear (sec/10)	10	20
Track Green (sec)	10	0
Track Pedestrian Clear (sec)	0	0
Track Yellow Change (sec/10)	40	0
Track Red Clear (sec/10)	10	0
Dwell Green (sec)	10	0
Return Pedestrian Clear (sec)	15	15
Return Yellow Change (sec/10)	40	40
Return Red Clear (sec/10)	10	20

* Preempts 3 through 6 were not used during simulation study.

Table 5. Controller Settings Programmed into Preempts 1 and 2 to Provide Simultaneous and Non-Vital Preemption.

		NEMA Phase Number							
		1	2	3	4	5	6	7	8
Preempt 1	Track Green	-	-	X ⁽¹⁾	-	-	-	-	X
	Dwell	-	-	-	-	-	-	-	-
	Cycle	-	Green ⁽²⁾	-	Green	Green	Green	Green	-
	Ped Cycle	-	Actuated ⁽³⁾	-	-	-	Actuated	-	-
	Exit Phase	-	-	X	-	-	-	-	X
	Phases Called at Exit	X	X	X	X	X	X	X	X
Preempt 2	Track Green	-	-	-	-	-	-	-	-
	Dwell	-	-	X	-	-	-	-	X
	Cycle	-	-	-	-	-	-	-	-
	Ped Cycle	-	-	-	-	-	-	-	-
	Exit Phase	-	-	-	-	-	-	-	-
	Phases Called at Exit	-	-	-	-	-	-	-	-

⁽¹⁾ "X" indicates parameter is active; "-" indicates parameter is not active.

⁽²⁾ "Green" indicates that phase will cycle with a green indication during preemption sequence.

⁽³⁾ "Actuated" indicates that pedestrian phase will operated in actuated mode (i.e., respond to calls) during preemption.

MEASURES OF EFFECTIVENESS

Table 6 shows the measures of effectiveness (MOEs) used to evaluate the NVAP treatments examined in this simulation study. These measures have been used in past research to examine alternative highway-grade crossing treatments (28,29).

Table 6. Measures Used to Evaluate the Effectiveness of NVAP Treatments on Intersection Safety and Operations.

Safety-Oriented MOEs	Operations-Oriented MOEs
<ul style="list-style-type: none"> • Number of pedestrian clearance time truncations. • Number of vehicle minimum green truncations. • Summation of unsafe time. 	<ul style="list-style-type: none"> • Queue length on the approach crossing the track. • Delay on non-track approaches. • Average intersection delay.

The safety-related MOEs indicate how well the NVAP system addresses non safety-critical issues such as:

- termination of pedestrian clearance intervals,
- shortening vehicular minimum green times, and
- descending of gates on stationary or slow-moving vehicles.

The operations-related MOEs indicate the relative operational cost or benefit resulting from the implementation of the NVAP system. Ideally, one would require a successful NVAP system to produce benefit from both a safety and operational viewpoint, but this may not be possible in all cases.

SIMULATION RESULTS

Effects on Pedestrian and Vehicle Safety

Table 7 shows the effects the different preemption strategies had on the number of times the pedestrian clearance interval, pedestrian walk interval, and vehicular minimum green interval was forced to truncate earlier during the preemption sequence. From the simulations, we found that we were able to reduce the number of times that the pedestrian clearance interval was truncated using both the NVAP – Type 1 and NVAP – Type 2 strategies, compared to when we used the simultaneous preemption strategy to clear the

grade crossing. We also found that NVAP – Type 2 resulted in the fewest number of truncations of the pedestrian walk interval. This result was to be expected because NVAP – Type 2 was designed to prevent the pedestrian walk interval from becoming active if there was insufficient time to completely service the full pedestrian interval. We also found that when we used NVAP – Type 1 we were able to reduce the number of times that the vehicular minimum green interval was truncated by approximately 30 percent.

Table 7. Effects of the Different Preemption Strategies on Pedestrian and Vehicle Phase Truncations.

Signal Interval	Frequency of Interval Truncations		
	Simultaneous Preemption	NVAP – TYPE 1	NVAP – TYPE 2
Pedestrian Clearance	18	2	2
Pedestrian Walk	8	6	1
Vehicular Minimum Green	32	19	26

In addition to looking at the number of times the pedestrian and minimum green intervals were truncated, we also averaged the amount of time, in seconds, that these intervals were truncated. For this study, the smaller the average duration of the interval truncation, the closer the interval was to normal operations. [Table 8](#) shows both the average amount of the time that the various safety-related signal intervals were reduced for each of the preemption treatments and the resulting duration of the intervals when a truncation occurred. We found that with NVAP – Type 1 and NVAP – Type 2, the resulting reductions were around one second, while the simultaneous preemption caused an approximately 10-second reduction in the pedestrian clearance interval when a truncation occurred. This means that even when a truncation occurred with the NVAP – Type 1 and NVAP – Type 2 strategies, we were still able to provide closer to the normal pedestrian clearance interval (15 seconds) than the simultaneous preemption.

We also looked at the amount of reduction in the Pedestrian Walk intervals when a truncation occurred. We found that under simultaneous preemption, the average amount of time that the Pedestrian Walk interval was reduced was approximately two seconds. We also found that both the NVAP treatments caused an average reduction in

the pedestrian walk interval of approximately three seconds. This means that when the NVAP strategies caused a pedestrian walk interval, it was generally a more severe truncation than when the simultaneous preemption caused a truncation in the pedestrian walk interval.

Table 8. Average Reduction in Pedestrian and Vehicle Phase Intervals When a Truncation Occurs.

Signal Interval	Average Duration of Interval Truncations		
	Simultaneous Preemption (seconds)	NVAP – Type 1 (seconds)	NVAP – Type 2 (seconds)
Pedestrian Clearance	10.048	1.219	0.797
Pedestrian Walk	1.667	2.997	3.110
Vehicular Minimum Green	5.689	4.225	6.284

Finally, we also looked at the amount of reduction that occurred in the vehicular minimum green interval when a truncation occurred. We found that NVAP – Type 1 strategy resulted in the smallest reduction in the green interval (slightly more than a four-second reduction), while the NVAP – Type 2 strategy resulted in a reduction of slightly over six seconds. From a practical standpoint, the amount of reduction was approximately the same with all three preemption strategies.

Average Intersection Delay

Table 9 shows the average intersection delay produced by each of the preemption strategies examined in these simulation studies while Table 10 shows the results of the analysis of variance statistical test. These tables show that, on average, the NVAP – Type 1 strategy had a tendency to increase the average intersection delay by approximately nine seconds compared to simultaneous preemption strategy. We determined that this increase was statistically significant at a 95 percent confidence level. We expected this increase in delay with the NVAP – Type 1 strategy because it has been specifically designed to dwell in the phase crossing the railroad tracks (Phase 3 in this case) once the other phases have cleared to wait on the simultaneous preempt to occur.

These tables also show that NVAP – Type 2 produced only a slight increase in the average intersection delay compared to the simultaneous preempt conditions. The statistical analysis indicated that this increase was not statistically significant. In fact, we did not expect to see any increase in delay with the NVAP – Type 2 strategy, because NVAP – Type 2 does not impact the vehicular phases – only the pedestrian phases. Although not measured, we would expect pedestrian delays to increase, however, as a result of implementing NVAP – Type 2.

Table 9. Average Intersection Delay Produced by Each Preemption Strategy.

Preemption Strategy	Average Intersection Delay (secs/veh)	Standard Deviation (sec/veh)	Sample Size
Simultaneous Preempt	69.43	7.44	40
NVAP — Type 1	78.75	12.63	40
NVAP — Type 2	69.76	8.36	40

Table 10. Results of Statistical Analysis of the Impacts of the NVAP Strategies on Average Intersection Delay.

Initial Strategy	Compared to	Tukey's Statistic	Statistically Significant?
Simultaneous Preempt	NVAP – Type 1	-6.05148	Yes
	NVAP – Type 2	-0.21695	No
NVAP – Type 1	NVAP – Type 2	5.83452	Yes

Average Queue Length

We also examined the average length of the queue on the railroad track phase produced by each of the preemption strategies. [Table 11](#) and [Table 12](#) show the results of this analysis. As [Table 11](#) shows, the simultaneous preempt had the tendency to produce the longest queue lengths on the railroad track phase (71.03 feet) while the NVAP – Type 1 strategy produced the shortest queue length (66.31 feet). However, the results of the analysis of variance (ANOVA) indicated that these queue lengths were not statistically different. Therefore, we concluded that none of the strategies had a greater (or less of an) impact on the average queue length on the railroad track phase than any of the other strategies.

Table 11. Average Queue Length Produced by Each Preemption Strategy.

Preemption Strategy	Average Queue Length (feet)	Standard Deviation (feet)	Sample Size
Simultaneous Preempt	71.03	9.08	40
NVAP — Type 1	66.31	11.10	40
NVAP — Type 2	68.48	8.36	40

Table 12. Results of Statistical Analysis of the Impacts of the NVAP Strategies on Queue Lengths Crossing the Railroad Tracks.

Initial Strategy	Compared to	Tukey's Statistic	Statistically Significant?
Simultaneous Preempt	NVAP – Type 1	3.05302	No
	NVAP – Type 2	1.64835	No
NVAP – Type 1	NVAP – Type 2	-1.40467	No

CHAPTER 4: NON-VITAL ADVANCE PREEMPTION SYSTEM DESIGN

This chapter will discuss the architecture and design of the Non-Vital Advance Preemption (NVAP) system utilized to conduct the research. The NVAP system will follow an architecture that serves several purposes. First, the architecture provides a division of tasks that allows a generous degree of flexibility to be attained when designing specific equipment to accomplish the tasks. The division also enables independent work tied together by data flows. Finally, the architecture lays out a path that is congruent with recent standards activities in the highway-rail grade crossing community. As a subset of the system design, the NVAP system specification ([Appendix A](#)) and implementation guidelines ([Appendix B](#)) are also included.

NVAP SYSTEM CONCEPT OF OPERATION

The NVAP system will be deployed in conjunction with a simultaneously preempted single track intersection as an enhancement, not as a replacement for simultaneous preemption. The vital simultaneous preemption from the railroad will always ensure safety in the intersection no matter what operations the NVAP system initiates. Trains moving toward the preempted intersection will be detected earlier than the simultaneous preemption system through the use of off right-of-way train detectors. At a minimum, one train detector will be required on either approach to the preempted intersection yielding a minimum total of two train sensors required. Status information from the train detectors will flow to a receiver at the preempted intersection. The train sensors will be autonomous (not polled from a master) and only deliver information about the train it is detecting. In other words, the sensors will not *depend* on incoming information from any other devices not at their site such as other train detectors. Train sensors *may* use information overheard from other sensors to enhance their own operation. This extra communication may happen when more than two train sensors are deployed.

An NVAP Rail Controller (NVAP-RC) will be located at the preempted intersection and will receive transmissions from train sensors. The NVAP-RC will use

the inbound data from the train sensors to identify and track a train through the area encompassing the train sensors and the preempted intersection. The NVAP-RC will, at a minimum, calculate the arrival time of the train at the intersection. The NVAP-RC may calculate other data items (location, speed, position) but the arrival time at the intersection is the prime data element and all that will be required (from the railroad side) by the NVAP strategies to make traffic control judgments. The train arrival information will be relayed to an NVAP Traffic Controller (NVAP-TC) via a common standard wired communication link.

The NVAP-TC will host a computer program that:

- monitors the status of the intersection’s traffic signal controller,
- receives train arrival estimates from the NVAP-RC and,
- implements an NVAP strategy.

Each strategy uses traffic signal controller and approaching train data to calculate the action or actions the strategy will implement. An example is to issue a low-priority preempt ahead of the rail preempt. [Figure 15](#) shows the NVAP system layout and block diagram.

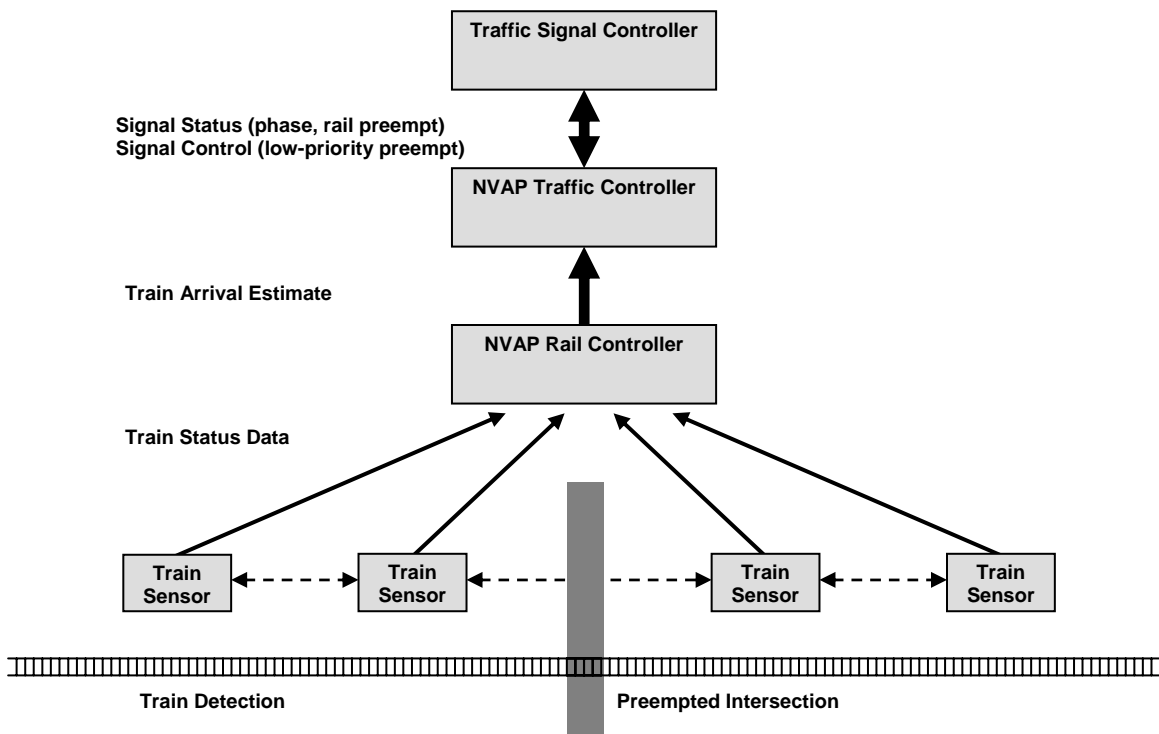

Figure 15. NVAP System Block Diagram.

NVAP SYSTEM ARCHITECTURE

The Non-Vital Advance Preemption System is organized into 3 functional components. Each component does a defined job but the way the job is accomplished may vary from installation to installation. This layered design approach allows for a large degree of flexibility for layer internal designs and field installations while maintaining the base concepts identified in the NVAP strategies. A data flow diagram among the defined components (layers) of the NVAP system is shown in [Figure 16](#).

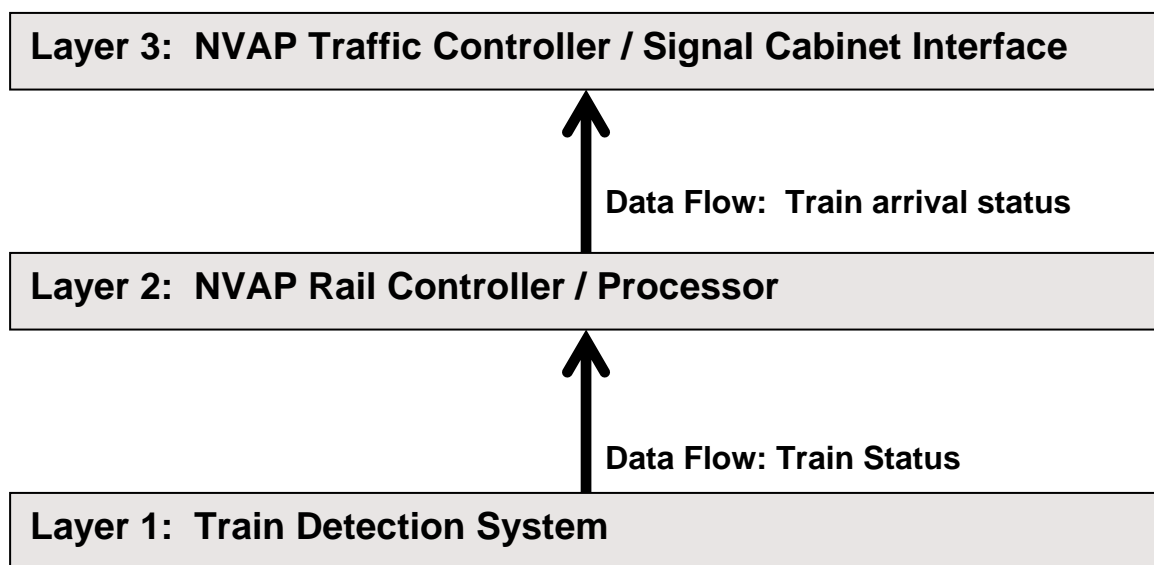

Figure 16. NVAP System Data Flow.

Layer 1 contains all the equipment and supporting devices to detect trains on the instrumented section of track near the signalized intersection targeted for NVAP deployment. In a traditional simultaneous preemption intersection, the layer would contain a railroad maintained track circuit that continually monitors a zone around the intersection for the presence of a train.

In the NVAP scenario, the layer contains the simultaneous preemption track circuit interface (typically Preempt 1) and additional non-railroad maintained train detection devices. Example sensors for such train detection devices were listed in [Table 1](#). Only single track scenarios will be considered to reduce the initial complexity

of the design. The inclusion of multi-track logic is possible but beyond the scope of this research.

This project will focus on two approaches for train detection. The first approach utilizes the radar-based train detection system deployed in College Station, Texas, as part of TxDOT research project 0-1752. This system uses Doppler radar train detection stations deployed at approximately 1 mile to 1.5 mile intervals. The train detection stations continuously scan a small area of railroad track looking for a train. When a train is found, the detection stations transmit train status data including direction of travel, speed, location, and station health data. This information is the data flow out of layer 1. This information does not contain arrival estimates but rather operational data on individual trains. This layer 1 architecture allows the train detection station data feed to remain train status oriented and not add any specific data fields pertaining to train arrival at points within the corridor. The architecture easily fits with the train detection stations as deployed in College Station.

An alternate method of train detection is to analyze a group of preempts along a rail / roadway corridor. A train detection station becomes a site that monitors and communicates the status of each preempt. Individual knowledge of a preempt reveals, at best, the approach or presence of a train. Unfortunately, no direction, speed or location information can be recovered directly from an *individual* preempt. These elements will have to be either estimated or inferred based on measurements of more than one preempt. Appendix C illustrates a novel approach using existing traffic signal controller communication channels to transport the preemption data.

Layer 2 contains the equipment to receive information from the layer 1 Train Detection Packages (TDPs to NVAP-RC). Layer 2 does not share any data with layer 1. As previously stated, layer 1 provides data on an individual train. Given the distance under consideration for the advance preemption and the single track limit, one train in the zone of interest at any time is a reasonable assumption. Layer 2 receives these data via a communication link (e.g., wireless) and processes it into train arrival information. Layer 2 equipment may reside in the traffic signal cabinet or in the railroad bungalow (cabinet). In the case of a traditional simultaneous preemption intersection, the layer 2 device is located in the railroad bungalow and is simply a relay. The relay is actuated by

railway equipment that monitors the railroad track circuit. The railway equipment may be a modern constant warning time controller or an older, simple track circuit presence detection system.

The preemption relay delivers a simple contact closure to the highway traffic signal controller. This link can be thought of as the legacy layer 2 to layer 3 one-way data flow (railroad grade crossing controller to highway traffic signal controller). There has been some movement in recent years to provide a richer interface to highway traffic control systems. The IEEE 1570-2002 standard entitled “*IEEE Standard for the Interface Between the Rail Subsystem and the Highway Subsystem at a Highway Rail Intersection*” was officially published in October 2002 (16). The standard describes a logical and physical data interface between railroad equipment and highway equipment. The interface identifies many new pieces of information never before available. The information can be categorized into three groups:

- grade crossing operational state,
- approaching train information, and
- roadway obstacle detection state.

Grade crossing operational state includes placeholders for the following data:

- number of trains associated with the crossing,
- crossing health indicator,
- crossing gate status (gates up or down),
- train direction,
- crossing occupancy by train (island occupied),
- estimated time to grade crossing warning system activation, and
- crossing warning system activation (lights, gates, bells active).

This group of data elements should be the easiest to acquire using current design concepts for a grade crossing controller (also known as a ‘predictor’). With the possible exception of number of trains and train direction, the remainder of the data should be available within the grade crossing predictor device. Although it is likely the information is

available within the device, it is not likely to be exposed for integration with other systems.

Approaching train information identifies the following data elements:

- train classification (passenger, freight, etc.),
- train movement plans (station stop, through move, etc.),
- estimated time of arrival,
- estimated time of departure,
- estimated speed at crossing,
- train in the crossing (island occupied),
- estimated train length, and
- direction of train travel.

This group of data, with the exception of estimated time of arrival, island occupied, and direction, will be much more difficult, if not impossible, to recover from current design grade crossing controllers. The addition of this information will likely require a significant amount of investment on the railroad equipment side. It is unlikely this information will become available without new technology being adopted by the railroads and railroad equipment vendors.

Finally, a new group of data elements was defined to convey roadway obstacle information. These data flow from the roadway equipment to the railway equipment and include items such as roadway equipment health, vehicle barrier status, and obstacle presence detection. Information traditionally flows from the railroad equipment to roadway equipment without any return flow. Adoption of a data flow from the roadway to the railroad equipment is likely to be a longer term process.

The standard defines a serial communication link between the railroad equipment and the roadway equipment. This research project will also use a serial communication interface between layer 2 and layer 3. Although a very similar communication design could be used, a simpler communication solution will be adopted for this project for expediency. A simple American Standard Code for Information Interchange (ASCII) based protocol will be defined and used throughout the project.

Layer 3 contains all equipment required to receive the data flow from layer 2, process the data, host the NVAP algorithms, and manage the interface to the traffic signal controller / cabinet. There is no return data flow from layer 3 to layer 2. In essence, layer 2 is considered part of the railroad control system and layer 3 part of the highway control system. The division also allows independent work to be conducted on the tasks each layer requires. This project will design and build both layer 2 and layer 3 hardware. Each hardware product will be totally stand-alone and operate strictly upon the data flow indicated here. An obvious future advancement would be to combine the duties of layer 3 directly into the traffic signal controller.

NVAP ARCHITECTURE – LAYER 1

The task of layer 1 is to detect trains around the zone of interest of the target grade crossing and provide as much operational information about the train's movement as possible. The solutions chosen for this project are radar train detection and train detection through preemption monitoring. The trains must be detected at a distance far enough away to provide useful advance arrival information. For the purposes of this project, an advance time of approximately 60 seconds was desired. The advance notification or warning time coupled with anticipated train speeds define the zone of interest around the target grade crossing as shown in [Figure 17](#).

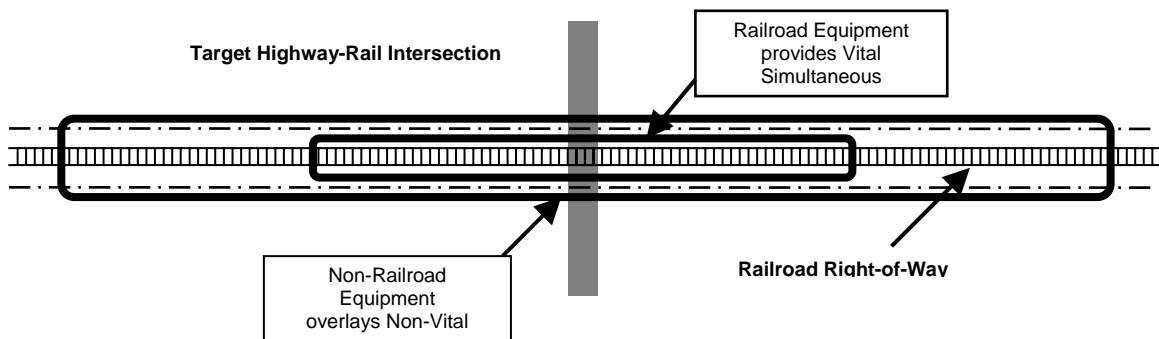

Figure 17. Zone of Interest.

For an expected train speed of 40 miles per hour (mph), trains need to be first detected at approximately 3500 feet from the target intersection. Train detectors must be

placed approximately 3500 feet on either side of the target intersection and outside the railroad's right-of-way. The distance will yield approximately 60 seconds advance warning time and the railroad maintained simultaneous preemption signal will provide a minimum of 20 seconds warning time before the train arrives at the intersection.

The radar-based train detection solution will utilize products from a past TxDOT-sponsored research project. Project 0-1752, "*Integrating Train Information for Advanced Transportation Management*," developed an off railroad right-of-way train detection and tracking system (30). The project defined a Train Detection Package (TDP) which was the component installed in the field to detect trains. There were other components to the developed system but the TDP is all that will be required in this research effort.

The TDP is comprised of:

- a Train Sensor Unit (TSU),
- an accompanying Field Processor Unit (FPU),
- a communication Network Interface Unit (NIU), and
- a Power Source/supply (PS).

The FPU receives and manages all data to and from the TSU as well as the NIU. Under control of the FPU, the TSU continually scans the forward area for movement. The TSU delivers, at minimum, target speed and direction via a serial data connection with the FPU. Current technology in use for the TSU is doppler radar. These data are packaged in a serial stream from the sensor and delivered to the FPU. The FPU polls the TSU at a rate of 15 times per second. Return data samples from the TSU are input into an algorithm that filters or "smoothes" the data and attempts to reject false targets. The new data stream is presented to a routine that calculates train length, train position, and true train speed. [Figure 18](#) shows the TDP block diagram.

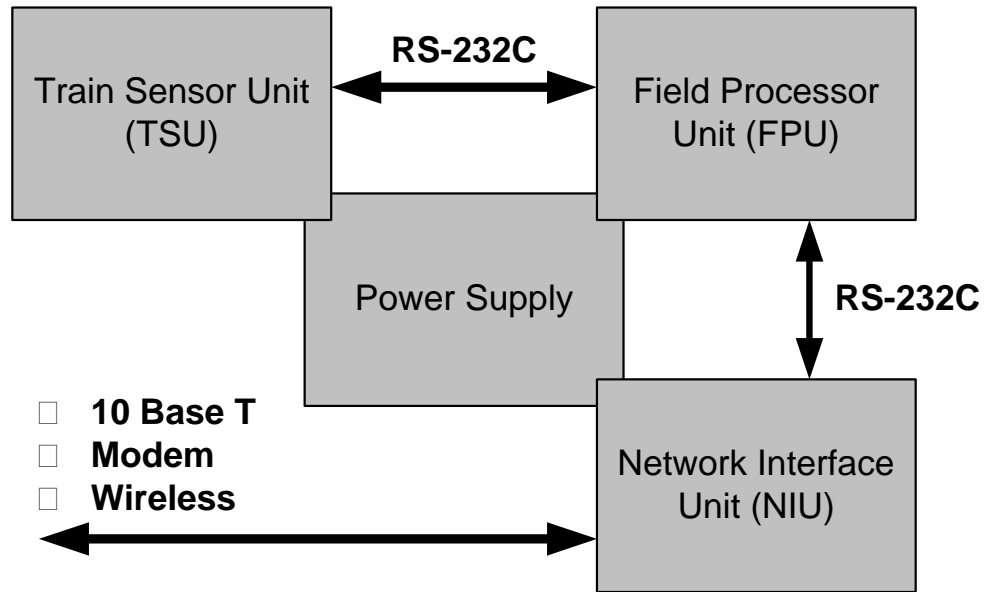

Figure 18. Train Detection Package Block Diagram.

The NIU is the site’s communication link back to a central processing system. This research will use an Ethernet network solution (wired, wireless or a combination of both) for communication between the train detectors (TDPs) and the NVAP-RC. A terminal server, a device used to interface an RS-232 data stream onto an Ethernet network, will be used as the NIU. A terminal server will also be used to interface the NVAP-RC to the network. During normal operation, the TDPs send messages to the NVAP-RC and do not expect to receive any in return. All communication flows from the field to central point, the NVAP-RC. A TDP may listen for other TDPs’ messages as a method to verify an operational communication network. If no messages are overheard in a defined period of time, the TDP may choose to execute a site restart (mainly a power cycle on the NIU gear) in an effort to solve the apparent communication failure. This action is simply a ‘smart’ system recovery or self healing activity but is not required of a site.

Another approach for train detection is to reuse the railroad’s own train detection by simply monitoring rail preemption in a preempted intersection. The approach would be viable given that there are several preempted intersections in the zone of interest and neighboring areas. Although preempt monitoring is attractive from a cost perspective (it is already there and available), the amount of true information that can be extracted is very limited and much less than that available from a radar-based system. Preemption is

a simple relay closure. The closure signals to the traffic signal controller a train is *at least* 20 seconds from the intersection – nothing more. The indication does not convey an upper time limit to the arrival time (at most 40 seconds from the intersection, for example). Additionally, preemption does not indicate a definitive location, speed, or direction. A preempt can indicate a train is approaching (on the approach) or something has just been detected in the ‘island circuit.’ The island circuit is the railroad’s way of determining if any part of the train is fouling the actual roadway intersection. Routine maintenance activities on the railroad equipment appear as live trains which the NVAP system must consider.

NVAP ARCHITECTURE – LAYER 2

Layer 2 receives information regarding trains moving in and around the zone of interest by layer 1 train detectors. The layer analyzes the information and creates an estimated time of arrival of the train (or estimated time of preemption at the target intersection) for transmission to layer 3. There is no product from the prior train monitoring project which can easily accomplish the layer 2 task; therefore, a new design was required. In addition, a layer 2 product will need to be designed specifically for a radar-based layer 1 design and a different design will be required for the preempt-based layer 1 design. Obviously, a single design would be preferable but a preempt-based layer 1 system does not deliver a rich data stream (i.e., speed, direction, location, etc.) like a radar-based layer 1.

The preempt-based controller design will incorporate layer 1 and layer 2 functionality into a single device. The approach is reasonable as preempts are very simple to measure, requiring a minimum of processor power and are located only at highway rail grade crossings, a location which could logically use the layer 2 outputs. The layer 2 to layer 3 data feed will use a very simple ASCII text protocol and deliver only estimated time of arrival information and possibly simple health indications due to the limited data available at each location.

The design approach was to create a small microcontroller which would execute the layer 2 function and remain isolated from upper layer equipment. The IEEE 1570-

2002 standard essentially defines a layer 2 device (16). The NVAP controller (our layer 2 device) follows many of the high level design ideas of the IEEE 1570-2002 standard but simplifies the communication requirements to allow for easier handling and debugging. The NVAP controller follows the IEEE standard concept in several important areas:

- one way communication – railroad equipment to highway equipment,
- communication error detection,
- message sequence numbering,
- once per second transmission (not polled) of vital information, and
- inclusion of health information.

The IEEE standard contains many more data elements than needed and accessible in this project. The standard also calls out certain higher-level requirements for communication which are common in the railroad industry but would unduly complicate this research effort. For that reason, a simple ASCII based protocol was devised to package the layer 2 data. As indicated above, the protocol contains many of the same data elements and follows the same procedural concept as the IEEE 1570-2002 standard. In recognition of the IEEE 1570-2002 standard, the message will be named NVAP Approaching Train Information (ATI) Message or NVAP-ATI. The message is further defined in [Appendix D](#).

Radar-based NVAP Rail Controller Design

Researchers can use the hardware from TxDOT project 0-1752 as a starting point for the new design. Since the TDP product will be reused from the past project, the communication protocol defined in the 1752 project will be reused for the layer 1 to layer 2 communication link in the radar-based layer 2 design. The data feed from layer 2 to layer 3 (NVAP-ATI) will use a similar easy to read ASCII text protocol with data fields similar to the IEEE 1570-2002 protocol.

The NVAP controller will use a Wilke-Technology microcontroller, shown in [Figure 19](#), as the hardware base. The Wilke-Technology offering has been used on

numerous research projects and has proven itself to be a very good choice for a low cost, robust, and reliable computation platform. The microcontroller supports multi-tasking which will be utilized in this design. Multi-tasking supports multiple independent processes running simultaneously yet sharing system resources such as the real time clock, static random access memory, and serial communication drivers.

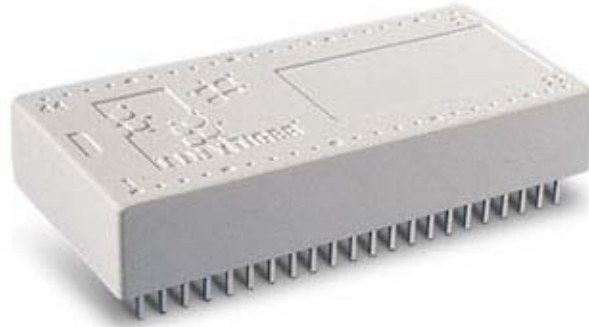

Figure 19. NVAP System Microcontroller.

Layer 2 tasks can be broken down into a few major areas of work. [Figure 20](#) shows the organization of the NVAP Rail Controller software. The software effort is categorized into three processes.

The Watchdog process initializes the controller upon reset and afterwards periodically checks variables in each of the running processes to determine if the process is operating in an expected fashion. If abnormalities are found, the watchdog restarts the process or resets the entire controller. Some of the items the watchdog checks are:

- that message is sent to the NVAP-TC once per second,
- that communication is received from train sensors,
- time since last train event, and
- preempt sampling.

These factors help ensure the NVAP system is receiving input, sending output, and the train management algorithm is not stalled. A final task for the watchdog is to initiate system resets based on requests from running processes. There may be conditions where a running process determines that a full system reset is the best way to overcome an issue.

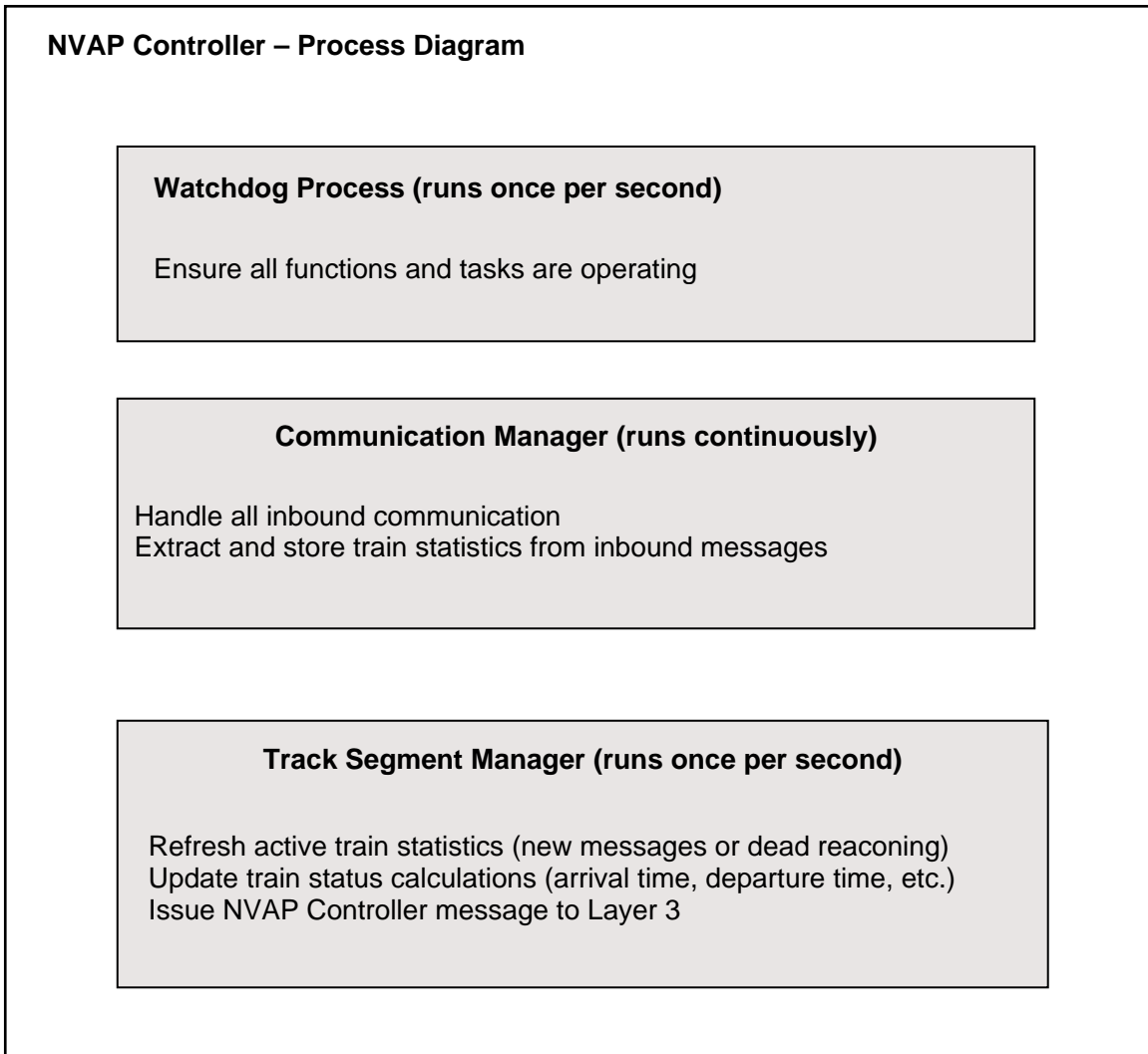

Figure 20. NVAP Controller Process Diagram.

The Communication Manager supervises the serial input channel (RS-232) and the processing of data received from it. The channel receives data from the NVAP system train sensors. The process pulls data from the serial buffer, organizes it into messages, and checks for errors. Error free messages are forwarded to either the broadcast, local, or adjacent sensor message handler. Although the software includes limited support for broadcast and local messages, they were not used in the project. All inbound messages are forwarded to the adjacent sensor handler.

Messages forwarded to the adjacent sensor handler are categorized as train detection, train projection or heartbeat messages. Train detection messages carry statistics pertaining to a live train at a sensor. Train projection messages estimate the

location of the train for a limited time after the tail of the train passes the sensor. Heartbeat messages contain health information from the individual sensor sites. Heartbeat messages are issued when trains are not being detected to maintain a continuous communication link between the train sensors and the NVAP-RC.

Train detect and train project (post detect) messages relay direction, speed, length, and location of a train at or just past a train sensor station. The data elements are extracted from the message and stored in a current train data array for use by the track management algorithm. A test is executed on the data to determine if the information passes a few simple requirements. An example is to inspect train statistics to determine if the value of the time code in the message progresses. A stalled time code is a simple indication of a failed train sensor station.

Train sensor station health messages convey a host of information to help diagnose potential problems at the station. Example data elements include:

- communication status of radar transmitter – radar not responding,
- background noise level – low probability of train detection,
- clock (time code) – communication link to train sensor station alive, and
- time since last train detected – failed detection algorithm.

The health message is not required for the NVAP-RC to operate. They are very beneficial for reporting system failures and to possibly shift system operation to adapt to the train sensor conditions.

The Manage Track Segment process is responsible for calculating the train's arrival at the target intersection as well as other train statistics. The process creates the NVAP-ATI Message from the calculations and forwards it to the outbound RS-232 serial channel for communication to the NVAP-TC. Train statistics managed include:

- distance head end of train away from intersection,
- distance tail end of train away from intersection,
- estimated time of arrival of train at intersection,
- estimated time of departure of train at intersection,
- train speed,
- train length, and
- train direction.

The process updates the train data elements once per second by accessing the current train data array. The array itself is updated upon every new train message arrival from the train sensors. The current train data array values are inspected and a train will be projected (dead reasoned) forward if data become stale due to communication problems with train sensors. The NVAP-ATI Message is created from the data elements and transmitted once per second.

Preempt-based NVAP Rail Controller/Detector Design

The preempt-based rail controller design will provide the layer 1 train detection function as well as the layer 2 NVAP-RC functionality in a single device. Given the integration of the two layers, the NVAP-RC function will require the device to receive messages from other similar devices. In the previous architecture, each train detector communicated directly with the NVAP-RC and it was assumed there would be only one stand-alone NVAP-RC. This solution puts an NVAP-RC with every train detector, thus the data flow concept is widened to allow device to device exchanges. In general, the device will listen to broadcasts from the other similar devices to extract data.

The device will output a simplified NVAP-ATI Message to the layer 3 device, the NVAP-TC. In general, the NVAP-ATI consists of estimated time of train arrival at the intersection and possibly some health information. The simplified NVAP-ATI for the preemption-based system will be called the NVAP-SATI (NVAP-Simplified ATI). The NVAP-TC design and functionality remains the same from the radar-based design. The NVAP-SATI message definition is documented in [Appendix E](#) and the modified architecture for the preemption-based NVAP system is shown in [Figure 21](#).

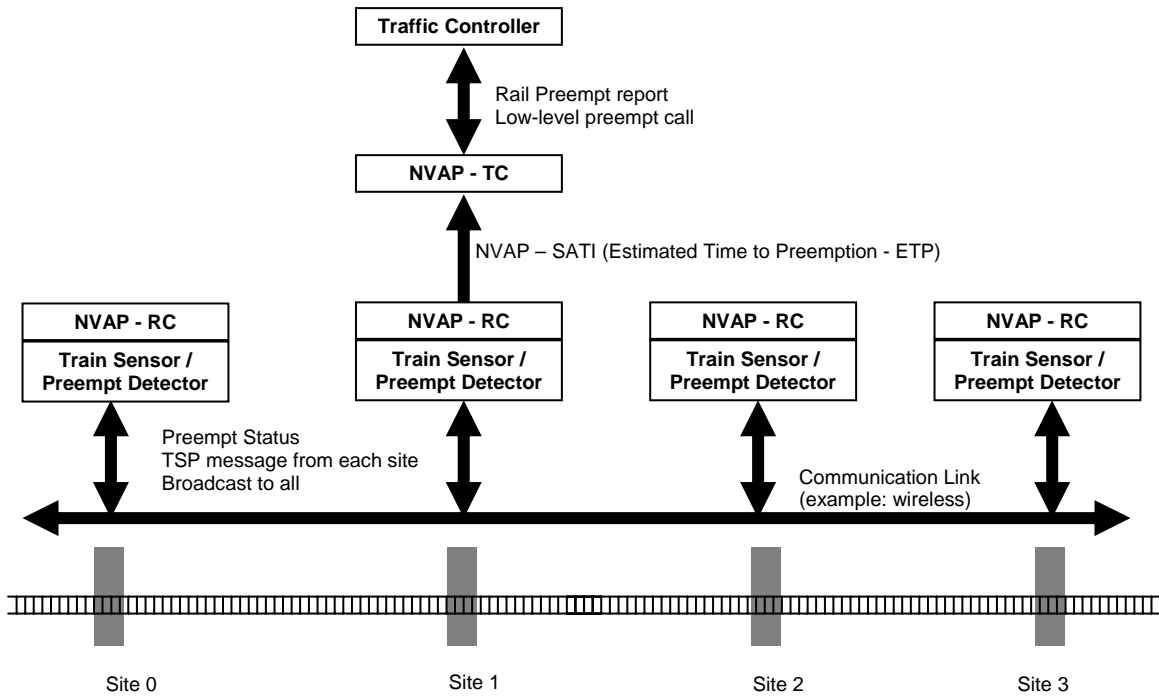

Figure 21. Preempt-based NVAP System Architecture.

It is important to fully understand the information content available in the preemption. Railroad grade crossing warning systems are designed to deliver a 20-second minimum warning time indication (preemption) for an approaching train. The preemption only conveys a time. A train tracking solution can be devised using preemption in a single track corridor if several issues can be overcome:

- no true knowledge of train direction,
- no true knowledge of actual train speed, and
- no true knowledge of train location.

As before, the research will also assume the zone of interest can contain only one train at a time and all events are triggered by this single train.

Train direction can be deduced by monitoring the progression of preemption throughout the corridor. Train speeds are not given by the traditional railroad system and will have to be predetermined. One approach would be to assume a train will travel at the maximum railroad posted speed through the corridor and use this as an average train speed. Another option is to measure the average time between preempt starts in the corridor. This solution may be best when working in a segment where railroad posted

train speeds change or trains are known to vary their speed. In either case, there is a significant amount of room for error, especially if the railroad issues new speed rulings for the line or if train crews exhibit a wide variability in how they choose to operate through the corridor. A design that records historical times between preemption starts and calculates an average among the travel time values may be warranted for a production level device.

The preemption-based NVAP system is designed to be deployed in a corridor which contains several preempted highway-rail grade crossings. A minimum of three preempted crossings are required (downstream, local, upstream intersections). Additional preempted intersections allow for a longer advance warning indication. In some applications, a traffic signal closed loop control system may be in place along the corridor. The design for the corridor system will incorporate the ability to multiplex or weave NVAP transmissions with closed loop communications over the same medium. Appendix C covers the topic of multiplexing with a closed loop communication system.

Each preempted intersection will periodically transmit a Time Since Preempt (TSP) value which is the number of seconds since the last onset of preemption at the specific intersection. A maximum TSP value will be defined and intersections will not increment above it. The TSP value will be encoded into a message and transmitted to the other intersections throughout the corridor. Each preempted intersection will listen for transmissions from the other intersections and maintain a database of the other intersection's current TSP value as well as their own.

The NVAP-RC will use the logic in which the intersection with the lowest TSP value has the most recent and therefore accurate information in the corridor regarding the moving train. The NVAP-RC will receive and store the latest TSPs from each preempted intersection in the corridor. The intersections will be scanned to find the lowest TSP value. The station with the lowest TSP value will have the most recent information and will be used to determine the train's location estimate. The train's travel time between individual corridor preempt starts will be considered a constant and is preprogrammed into each intersection's NVAP-RC system. Given the assumption of the same preempt start time to train-arrive-in-intersection time, the travel time between intersections will also be the travel time between preempt starts at the intersections. The combination of

constant travel time and indication a train is at a known time from an intersection (for example, 25 seconds) is sufficient to create an estimate of a train's arrival at intersections downstream.

Train direction is determined by use of the following logic. If a train is known to be in the corridor (i.e., any site TSP value is less than TSP maximum) and it has been a long time since a train has been at the local intersection (the TSP value is at the maximum for the local intersection), then the train must be approaching the local intersection. Note, a physical direction (i.e. north, south, etc.) is not known — only that the train is either approaching or past the intersection (i.e., not approaching).

Each intersection (NVAP-RC) calculates an Estimated Time to Preemption (ETP) once per second. The ETP value is the advance train arrival information conveyed in the NVAP-SATI message. Estimated Time to Arrival is the sum of ETP, Railroad Constant Warning Time, and the Railroad Buffer Time. A positive ETP value indicates a train is approaching the site and a value of zero indicates preemption has just been detected at the local site. The ETP value will decrement to -1 in the next second and be limited at -1 after the onset of preemption at the site. An ETP value of -1 is an indication that a train is not approaching the site and is the quiescent value of ETP between trains. A logic flow diagram is shown in [Figure 22](#). A typical train event scenario is illustrated in the following figures.

Operation Example

[Figure 23](#) depicts a rail corridor with four preempted intersections (Site 0 – Site 3) outfitted with the combination train (preempt) detector/NVAP-RC devices described in the preceding section. Travel times have been estimated between intersections based on the average train speed within the corridor and distances between the intersections. For discussion, consider a wireless network has been installed to support communication between the intersections and configured as a multi-drop network in which devices hear transmissions from all other devices.

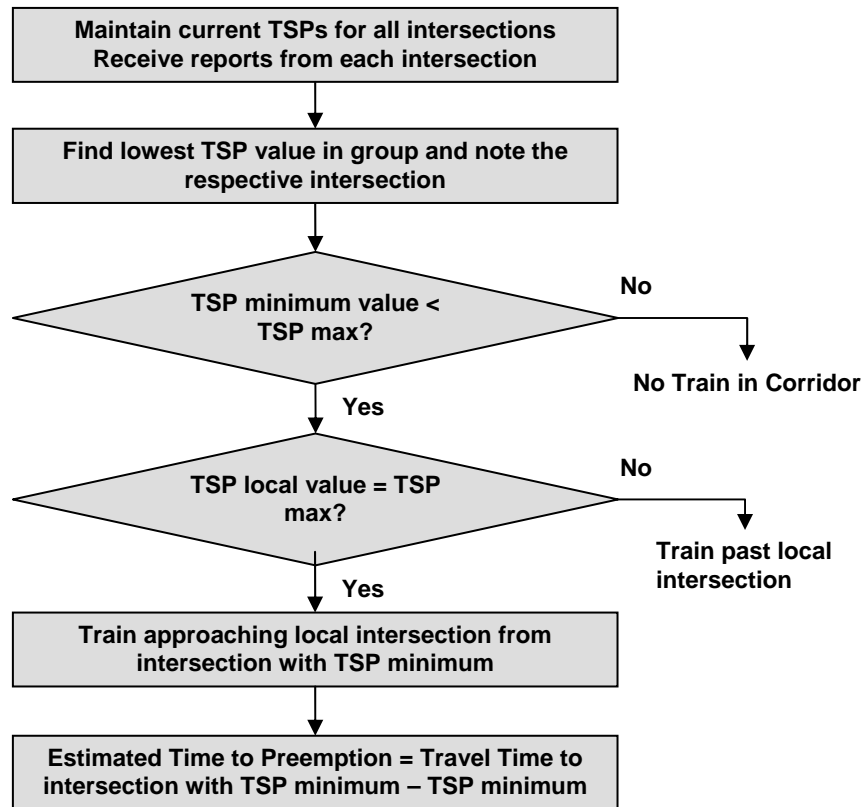

Figure 22. Logic Flow Diagram.

A simultaneous preempt time of 25 seconds (time between preempt start and train arrival in the intersection) will be assumed for all preempts in the corridor. TSP values are shown at the top of each intersection and are set to the static condition of 900 seconds for each TSP, the maximum TSP value. The conditions shown in [Figure 23](#) indicate it has been many minutes since a preempt start in the corridor and thus there are no moving trains detected in the corridor.

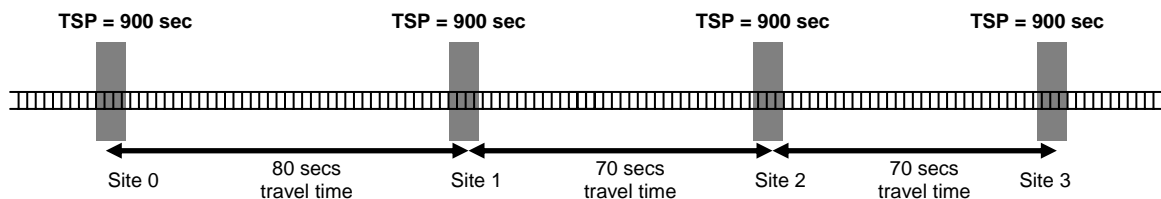

Figure 23. Rail Corridor with Preempted Intersections and No Trains.

Figure 24 shows a train has entered the corridor from the left and traveling toward the right. Site 0 is reporting a time since preemption of 65 seconds and thus the train's head end is 40 seconds past the intersection at Site 0 and 65 seconds past the time preemption began at Site 0. The other sites do not sense a local preempt but they do identify Site 0 as the smallest TSP value among the group. The other sites calculate it has been at least 900 seconds since the last preempt has begun therefore the train must be approaching their intersection from the location of Site 0 and the train is 40 seconds into its travel time between Site 0 and the local site. Indeed the train is traveling from the left to the right and approaching the remaining sites.

In this example, each of the four intersections are working and reporting properly. Once a train is detected in the corridor (a TSP value less than 900 seconds), each site calculates an estimated time to preempt start once per second. Site 0 preempt has been active for 65 seconds and the ETP at Site 0 is -1, denoting the train is past the location. ETP is forced to 0 upon preemption and decrements to -1 in the next second after preemption. Site 1 ETP is calculated as 80 seconds – 65 seconds = 15 seconds. Site 1 determines TSP minimum is Site 0 and Site 0 is an adjacent site. Any approaching train at an adjacent site will be projected inbound without regard to the operational status of the other sites. Site 2 and Site 3 also calculate the ETP of the inbound train but they also determine if each site between the train and their respective site is alive. If the site is alive, the train will not be projected past that site. The site must report a preemption (i.e., TSP = 0 seconds) for the train to be projected past.

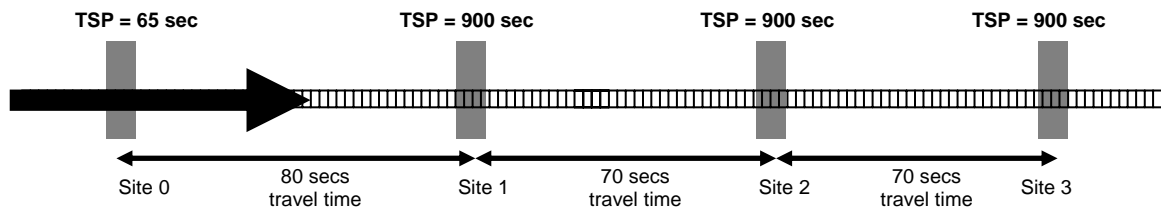

Figure 24. Train Enters Corridor.

Figure 25 shows the preemption just beginning at Site 1. The TSP value is 0 seconds and will increment each second. ETP at Site 1 is 0 and will decrement and hold at -1 in the next second. Site 0 determines TSP minimum is now Site 1 but since

Site 0 TSP is less than 900 seconds, the train is not approaching. Site 2 and Site 3 determine their TSP is still 900 seconds and thus the train is approaching. ETP at Site 2 is 70 seconds and ETP at Site 3 is 140 seconds.

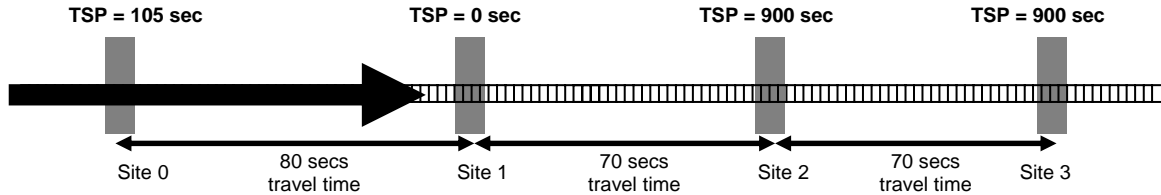

Figure 25. Preemption at Site 1.

Figure 26 shows the train has now progressed to the Site 1 intersection which is 25 seconds since the onset of preemption at Site 1. Figure 27 depicts the train at the onset of preemption at Site 2 and Figure 28 has the train arriving at Site 3 thus completing the progression through the corridor. Table 13 shows the various ETP times associated with each figure.

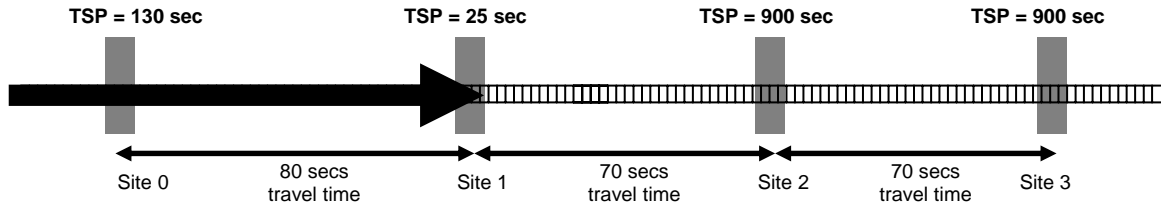

Figure 26. Train Arrives at Site 1.

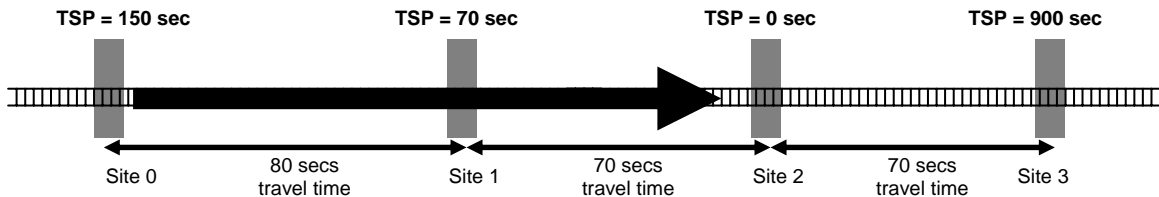

Figure 27. Preemption at Site 2.

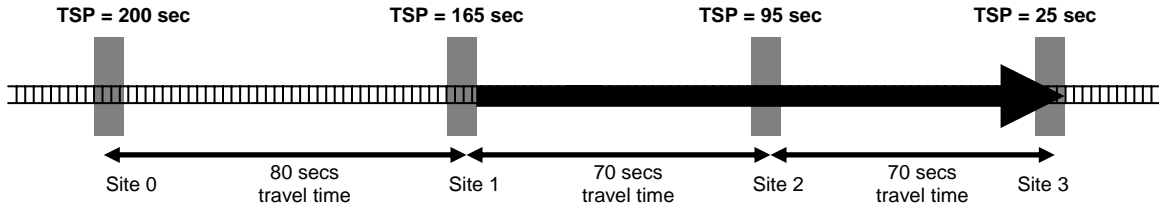

Figure 28. Train Arrives at Site 3.

Table 13. Estimated Time (in seconds) to Preemption Matrix.

Site	0	1	2	3
ETP per site – Figure 23	-1	-1	-1	-1
ETP per site – Figure 24	-1	15	85	155
ETP per site – Figure 25	-1	0	70	140
ETP per site – Figure 26	-1	-1	45	115
ETP per site – Figure 27	-1	-1	0	70
ETP per site – Figure 28	-1	-1	-1	-1

As the train exits the corridor each Site’s TSP increments back toward TSP maximum. The interim time is a waiting period to allow the train to completely clear the area. If train movements are expected to be closely coupled, TSP maximum must be adjusted in accordance. TSP maximum must also be large enough to ensure that the train will completely exit the zone.

Since the preempt-based NVAP system relies heavily on communication to other intersections, loss of a single intersection in the corridor can have big consequences if a system is not in place to recover from failed or offline sites. The NVAP-RC design includes a mechanism to identify and overcome single site failures. In general, the ETP value in each NVAP-RC is updated by reports from other intersections and projected in between reports. The NVAP-RC will not project beyond a point where it expects a preemption report. In other words, the NVAP-RC tracks a train’s progress through the corridor but will not project a train past an operable intersection without a valid report of preemption from the intersection. With this logic in place, each NVAP-RC must monitor the other intersections (NVAP-RCs) and determine if they are reporting. If a site fails to report for an extended period, the other NVAP-RCs must remove it from their active site

list. The removal then allows the NVAP-RC to project a train through the inoperative intersection and thus not loosing a 'lock' on the train.

NVAP ARCHITECTURE – LAYER 3

The NVAP software used a combination of data from the radio communications system, data entered from the user, and the status of the controller to influence the controller when particular situations occurred. Each NVAP system used a different combination of hardware, the status of the controller, and data entered by the user to determine what actions to take on the controller.

NVAP Type – 1

The NVAP Type – 1 system was located in a TS 1 cabinet in College Station, Texas. The hardware used for the NVAP Type – 1 system included a computer and a digital input/output (I/O) card that was used for communications between the computer and the cabinet. The NVAP Type – 1 system begins by computing an Advanced Notification Time Required (ANTR) value. The ANTR value is the sum of the following values, input by the user prior to beginning the program:

- Preempt Min Green Time,
- Selective Pedestrian Clear,
- Selective Yellow Change,
- Selective Red Clear,
- Track Green,
- Track Pedestrian Clear,
- Track Yellow Change,
- Track Red Clear, and
- Preempt Separator.

Once the ANTR has been calculated the NVAP Type – 1 system begins to receive an ETA value from the radio communications system as well as the status of the controller. The NVAP system continues to monitor the ETA until it sees a train approaching. Once a train is detected the system begins to compare the ETA to the ANTR value. As long as the ETA is greater than the ANTR no action is taken on the controller. When the ETA is at a value lesser than or equal to the ANTR a non rail preempt is sent to the controller via the digital I/O board. This preempt is kept active by the system until the rail preempt is activated. While the rail preempt is active the NVAP system simply monitors the status of the controller. When the rail preempt is no longer active the system begins the process over again and waits for another train to be detected.

NVAP Type – 2

The NVAP Type – 2 system was located in the same cabinet as NVAP Type – 1 and used the same hardware setup. Unlike NVAP Type – 1 no preempts are issued by this system. NVAP Type – 2 uses the ETA to determine if and when a pedestrian phase should be omitted. Once the system has been started it continuously calculates an Advanced Warning Time (AWT). The AWT is a sum of the red and yellow clearance times for the current phase and the pedestrian walk and clear times of the next phase. Each time the controller is at a point where it is going from one phase to the next a new AWT is calculated. At the same time the system is receiving the ETA from the train tracking system. If a train is detected, and the ETA is less than the calculated AWT for the next phase a pedestrian omit for the upcoming phase is sent to the controller. This omit is kept active until either the phase changes or the rail preempt becomes active, at which time the pedestrian omit is removed. Once the rail preempt is activated the system monitors the status of the controller until the rail preempt event is over. The system then goes back to its original state until the next train arrives.

NVAP Type – 1 (TS 2)

The system for NVAP Type – 1 (TS 2) was located in a TS 2 cabinet in Alice, Texas. The software for NVAP Type – 1 (TS 2) worked exactly as the software in NVAP Type – 1. However, because of the difference in cabinet types, the hardware for NVAP Type – 1 (TS 2) differed from that in NVAP Type – 1. The NVAP Type – 1 (TS 2) system consisted of a computer and a terminal server. The terminal server in NVAP Type – 1 (TS 2) replaced the digital I/O board used in NVAP Type – 1. The terminal server was used to communicate information between the computer and the cabinet. The computer sent and received User Datagram Protocol (UDP) packets to the terminal server. By doing this the computer was able to monitor the status of the controller and influence it at the appropriate times. The terminal server communicated to the cabinet through serial connections to the cabinet's Bus Interface Units (BIUs). This setup allowed the software to gather all the required information from the cabinet without being directly connected to it. Although the computer in this setup was located inside the cabinet it is possible that a computer located on the same network as the cabinet could influence it from any location.

RAIL CORRIDOR SIMULATION PACKAGES

Laboratory experimentation with the different NVAP devices was vital to the success of the research. A simulation package was developed which acted as a recorder/replayer for all the train detection station message traffic as well as the action of the rail preempt at Holleman Drive. The simulation package allowed early experimentation with the NVAP concept within a laboratory environment totally removed from the intersection. In essence, the NVAP system could be tested in the Translink[®] Laboratory using live or recorded train detection and preemption information. The simulation product provided an excellent mechanism to fine tune NVAP software and hardware.

A second software application was developed to simulate the progression of preempts in the Alice, Texas, corridor and to generate all the NVAP-RC messages so the NVAP-TC could be operated in the Translink[®] Laboratory. The simulation package

supported the experimentation with all aspects of the preemption-based train detection system.

CHAPTER 5: TEST IMPLEMENTATIONS

The test implementations were envisioned to occur in two different style corridors in Texas. The radar-based system was implemented in a corridor which already had the train detection devices installed. The corridors that qualify are the Wellborn Corridor in College Station, Texas, and the Hwy 90A Corridor in Sugar Land, Texas. The College Station Corridor is the original testbed for the radar train monitoring work conducted in TxDOT research project 0-1752. The corridor remains outfitted and operational.

The second radar corridor is located in Sugar Land, Texas, along approximately 6 miles of US Hwy 90A. The corridor uses the same radar train detection equipment as College Station. This research originally envisioned the Sugar Land Corridor to be the testbed for NVAP Strategies 3 and 4. After the project began, researchers received news that the corridor would be undergoing a significant construction project during the deployment stage of the research. The construction would potentially impact the data quality and create abnormal traffic situations. Given the information, the research team decided to eliminate the Sugar Land location for radar-based system testing. All radar-based train research would be conducted using the Wellborn Road Corridor in College Station.

The second train detection method investigated in this research involved monitoring intersection traffic signal preemptions along a rail corridor. The objective is to use preemption to locate trains and calculating the train's estimated time of arrival at other intersections along the corridor. From a broader perspective, the preemption system focuses on using available train data without having to outfit a corridor with radar train detection. The Texas Route 359 / Texas Route 44 Corridor through downtown Alice, Texas, was selected for a test implementation. Each testbed will be discussed individually giving a more detailed look at the corridor, an overview of the deployment and finishing with a presentation of findings.

COLLEGE STATION TESTBED

The testbed for the radar-based train detection system is the Wellborn Corridor in College Station, shown in [Figure 29](#). The portion of the corridor of specific interest during this research was along Wellborn Road (Farm to Market 2154) between George Bush Drive and the Harvey Mitchell Parkway (Farm to Market 2818). The corridor is comprised of a major arterial (Wellborn Road) with a nearby and paralleling single track railroad line. Wellborn Road and the rail line run between the east and west campuses of Texas A&M University north of George Bush Drive. George Bush Drive and Harvey Mitchell Parkway are the endpoints for this research project. Holleman Drive intersects Wellborn Road at approximately the midpoint between George Bush Drive and Harvey Mitchell Parkway. Holleman Drive, shown in [Figure 30](#), is a signalized intersection with simultaneous preemption and was the target intersection chosen for NVAP testing.

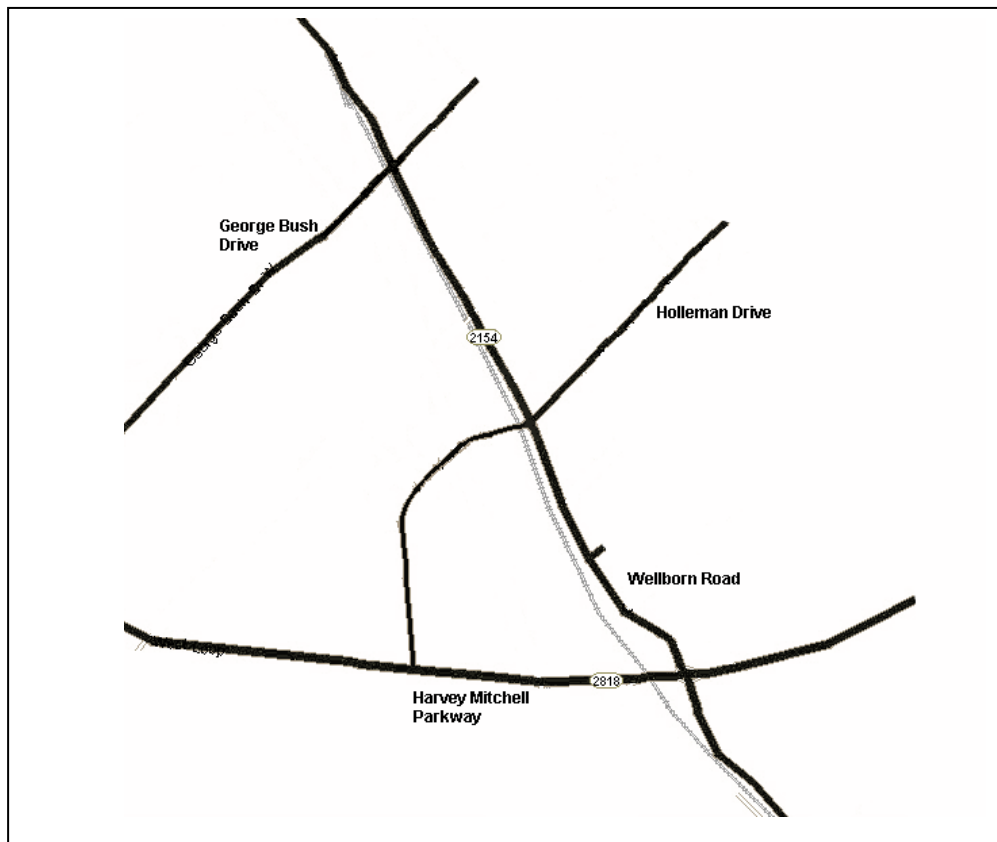

Figure 29. College Station Test Location.

The railroad line is part of the Union Pacific Navasota subdivision and hosts approximately 20 trains per day. The trains operate in both directions and appear to favor neither direction. The section of railroad is signalized (Centralized Traffic Control) and supports relatively close spacing (from a railroad perspective) between trains traveling in the same direction. Following trains can typically be as close as 5 or 10 minutes. Trains moving from George Bush Drive toward Harvey Mitchell Parkway are moving from the Texas A&M University campus area toward a less urbanized area of College Station. Trains typically are just beginning to accelerate as their rear passes through the campus area. Conversely, trains moving from Harvey Mitchell Parkway toward George Bush Drive are, in many cases, decelerating to meet a lower speed target near the campus area.



Figure 30. Holleman Drive Intersection.

Holleman Drive is the target intersection for the NVAP system. Holleman Drive is 3570 feet south of George Bush Drive and 3820 feet north of Harvey Mitchell Parkway. Radar train detectors are installed at or near the highway grade crossings at

George Bush Drive and Harvey Mitchell Parkway. The radar detectors continually scan the near railroad track looking for a passing train. Continuous communication is maintained between the two train detection sites and the NVAP system installed at Holleman. The radar train detectors identify and track trains moving toward Holleman and provide train statistics at least once per second. Harvey Mitchell Parkway is seen in the far distance in [Figure 30](#) and is the location of a downfield train detection station.

Holleman Drive is outfitted with a traditional simultaneous preemption system which is designed to start preemption at approximately 25 seconds prior to train arrival in the intersection. It is worthy to restate that the 25-second number is a target and not a guarantee. The railroad preemption system is designed to guarantee a preemption *at least* 20 seconds prior to train arrival. The railroad equipment adds some time to ensure the ‘at least’ concept. Field measurements suggest this extra time at the Holleman intersection is approximately 5 seconds. There will be some variation within the estimated 25-second start time on the railroad equipment. The variation is beyond our control.

NVAP algorithms need good estimates of train arrival. The radar system is able to continually monitor speed while the train is in front of a sensor station thus the resulting train arrival estimates are automatically updated to reflect current train characteristics. [Figure 31](#) illustrates the metric used to measure the quality of the train arrival prediction system which will be called decision to preemption time. The NVAP algorithms need to make a decision at a point 35 seconds ahead of preemption. A point 60 seconds away from the crossing is called the decision point. At 25 seconds away from the crossing the simultaneous preemption starts (preemption point). The decision to preemption time is the time difference between decision (when the train is estimated to be 60 seconds from the crossing or 35 seconds ahead of preemption) and the actual preemption start time. Obviously the decision to preemption time will vary based on the quality of the train tracking system estimates and the quality of the grade crossing equipment to estimate the train’s arrival at the crossing.

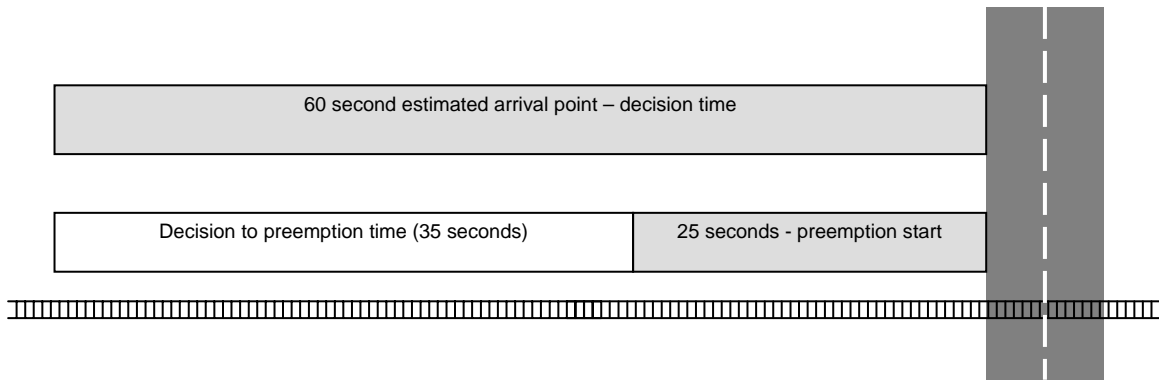

Figure 31. Decision to Preemption Time.

Figure 32 illustrates, in general, the ability of both the radar and the corridor preemption concept to predict train arrivals at Holleman Drive for southbound trains. This research did not use a true preempt at either George Bush Drive or Harvey Mitchell Parkway. Instead of a real preempt, the research used the first detection of a train to simulate the concept of preemption at these locations. The chart shows the decision to preemption time for southbound trains at Holleman Drive and the first detect (at George Bush Drive) to preemption time at Holleman Drive. The term *first detect to preempt* means the first sighting of a train at the downfield sensor to preemption at Holleman Drive. The decision point will then be a constant time after first detection assuming the train will be traveling at a constant speed over the full distance. Northbound trains will be addressed later.

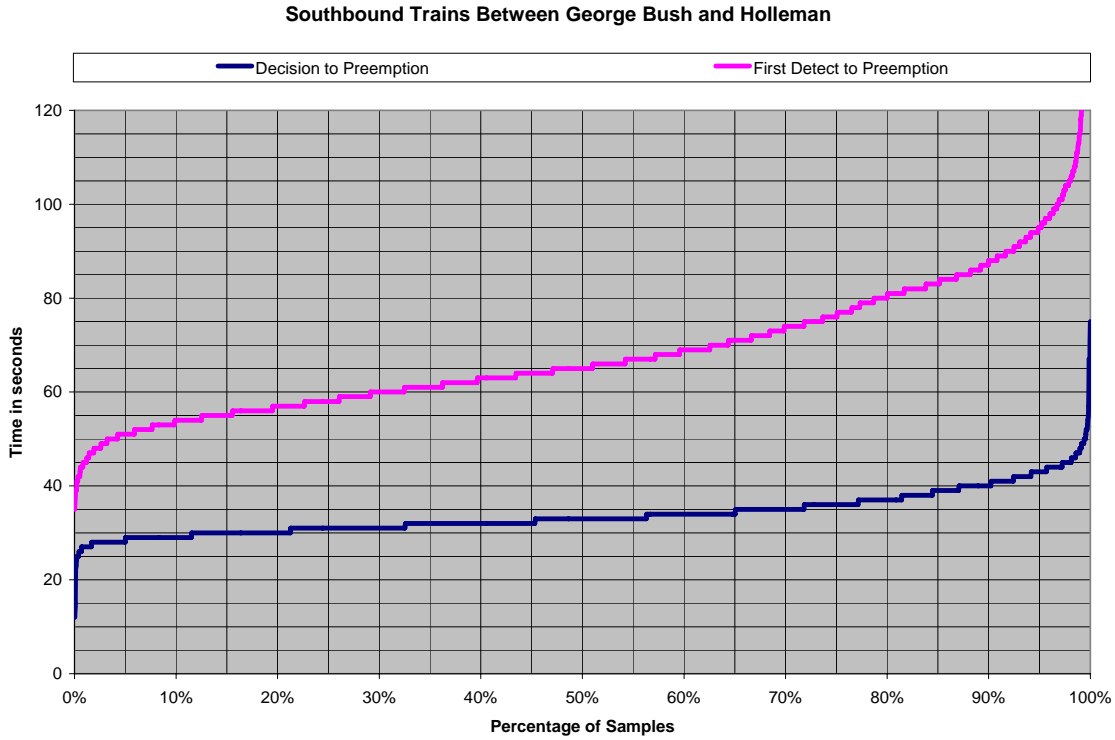

Figure 32. Decision to Preemption Time for Southbound Trains.

The graph plots the measured decision to preemption time from the shortest to the longest for 2480 southbound train movements. First detection (George Bush) to preemption is plotted the same way. The graph can be used to determine the probability of a southbound train arriving within a window of time for both train detection solutions (radar-based and preemption-based). The curve approaches horizontal when a large number of train events fall within a short window. Stating it differently, a near horizontal line is most desirable at the planned decision to preemption time (35 seconds in this research). Since there is nothing dynamic about the train predictions using the preemption only system, the decision point is simply a constant time after the initial preemption detection at George Bush Drive. For the southbound case, the decision time is approximately 30 seconds after detection at George Bush Drive; therefore, the decision to preemption time is simply 30 seconds less than the first detect to preemption time. The graph uses first detect to preemption time to separate the two curves while keeping the slope and time differentials the same. The graphic represents 2480 southbound train

movements in the corridor. [Figure 33](#) shows the distribution for 1462 northbound train movements.

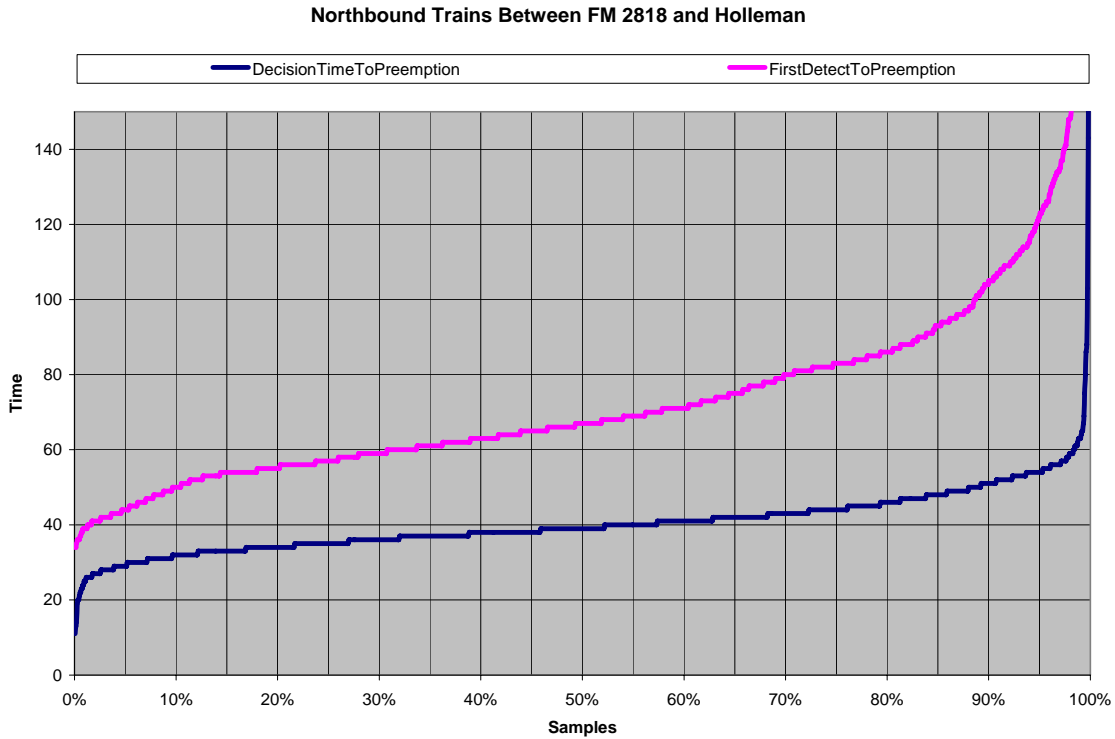

Figure 33. Decision to Preemption for Northbound Trains.

[Table 14](#) summarizes the results of the advance prediction of the Holleman Drive rail preemption. It is easy to see the value of the continuous radar data from the distributions in the preceding figures and a comparison of standard deviations. For the radar case, the average (mean) decision to preemption time is 34 seconds, which missed the target of 35 seconds by 1 second. The mean is very close to the expected and the error can be explained by observations of train movement characteristics in the corridor. Trains moving south (out of town) are more likely to be increasing their speed and thus would tend to arrive slightly early yielding a mean slightly under our expectations. Remember, the radar system must make its prediction at a point 35 seconds ahead of preemption and has no ability to update itself afterward even though it is measuring the train’s acceleration or deceleration. The system must commit 35 seconds in advance.

The mean decision to preemption time for northbound trains is 40 seconds, which missed the target by 5 seconds. Trains headed north are approaching a more congested

area near the campus and are moving into a restricted speed zone. Trains are more likely to be slowing their speed as they approach Holleman Drive. The speed slowing results in a less sharp slope on the right side of the graph. Other less evident factors could also be influencing the data for both approaches. For instance, the railroad track circuit may be more sensitive to trains on one approach as compared to the other. Another example might be one radar train sensor tends to deliver a slightly higher or lower speed. The train sensors were calibrated at the beginning of data collection to minimize this possibility. Although these situations are reasonable, the more probable cause is simply the general acceleration and deceleration of trains in the corridor.

Table 14. Distribution of Trains within a Time Interval around the Mean.

Metrics	Radar-based prediction	Preemption-based prediction
Southbound trains		
Mean	34 seconds	68 seconds
Standard Deviation	4.7 seconds	15.5 seconds
± 2 seconds of mean	44% of samples	17% of samples
± 5 seconds of mean	82% of samples	34% of samples
± 10 seconds of mean	96% of samples	71% of samples
Northbound trains		
Mean	40 seconds	72 seconds
Standard Deviation	7.5 seconds	25.9 seconds
± 2 seconds of mean	31% of samples	10% of samples
± 5 seconds of mean	59% of samples	26% of samples
± 10 seconds of mean	84% of samples	44% of samples

Table 14 also shows the probabilities of train arrival predictions being within a few example windows. Forty-four percent of the southbound trains arrived within two seconds of the mean. This probability moves up to 82 percent for a 10-second window (five seconds on either side of the mean). For northbound trains the probabilities go down for the same windows. Thirty-one percent of northbound trains arrived within two seconds of the mean and 59 percent arrived within five seconds of the mean. The arrival predictions based on first detect, our surrogate for preemption detection, show much less consistency. In the two- and five-second windows, the probabilities for the preemption-based system are less than half that of the radar-based system.

Table 15 gives some insight into the effect a train’s acceleration or deceleration can have on decision to preemption predictions. The table shows the difference in time between an estimate made at decision time (35 seconds away from preemption) and the actual preemption. For example, consider a train moving toward Holleman Drive in the corridor and slowing. At a point 35 seconds away from preemption at Holleman, the train is moving at 30 miles per hour and slowing. At the time of preemption the train has slowed to 25 miles per hour. The prediction system will have estimated preemption 7.8 seconds earlier than it actually would have happened for this specific profile. Looking through the examples in the table, it is easy to understand how errors of a few seconds are difficult to overcome when decisions have to be made ahead of the intersection preemption.

Table 15. Effect of Acceleration and Deceleration on Predictions.

Speed at Decision Point (mph)	Speed at Preemption (mph)	Real time (secs)	Estimated (secs)	Diff (secs)
15	10	52.7	35.0	-17.7
20	15	47.5	35.0	-12.5
25	20	44.6	35.0	-9.6
30	25	42.8	35.0	-7.8
35	30	41.6	35.0	-6.6
40	35	40.7	35.0	-5.7
10	15	18.2	35.0	16.8
15	20	23.0	35.0	12.0
20	25	25.7	35.0	9.3
25	30	27.3	35.0	7.7
30	35	28.5	35.0	6.5
40	45	30.0	35.0	5.0

NVAP Type – 1 Results

The NVAP Type – 1 strategy was tested first at Holleman Drive intersection using the radar-based train detection method for train arrival estimate data. Remember, the NVAP Type – 1 strategy is designed to issue a low-level preempt ahead of the rail preempt. The low-level preempt initiates a sequence in the traffic signal controller attempting to ensure a full pedestrian walk cycle (i.e. pedestrian time not truncated to get to track clearance phase). The rail preempt ensures safety. Data were collected for 321 train passages. Figure 34 presents the results of the pedestrian phase lengths just prior to a train event.

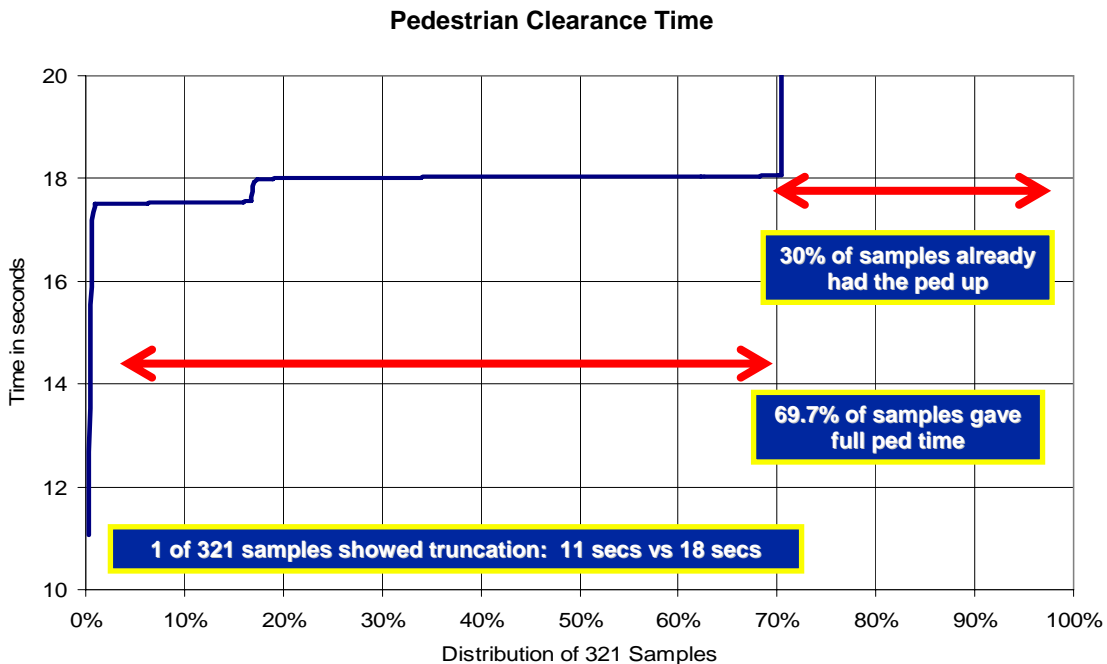

Figure 34. Pedestrian Clearance Time Prior to a Train.

The graphic clearly shows that the NVAP Type – 1 system provided for a full pedestrian clearance phase of 18 seconds for all but one instance of the 321 samples. In the single instance, the phase was truncated at 11 seconds instead of the full 18 seconds. The system had a direct influence on the controller in approximately 70 percent of the samples. For the remaining 30 percent, the controller was in a position such that the

pedestrian phase had already delivered the 18-second minimum time. In these instances, an immediate canceling of the pedestrian phase was not a truncation.

Using the NVAP Type – 1 strategy affects the overall length of the track clearance phase at the intersection. Figure 35 shows the impact the strategy has on the track clearance phase length. For 2.5 percent of the train samples, the controller was unable to get to the track clearance phase before rail preemption was received. In the remainder of the samples, the track clearance interval was greater than the programmed value of 13 seconds. The track clearance time was extended due to the NVAP Type – 1 algorithm from 13 seconds to approximately 45 seconds in a relatively even distribution. The distribution reveals that the likelihood of a 20-second track clearance phase is about the same as a 30-second phase. In general, one cannot predict the length of the phase with any degree of accuracy. Obviously, a long track clearance phase can lead to inefficiencies at the intersection.

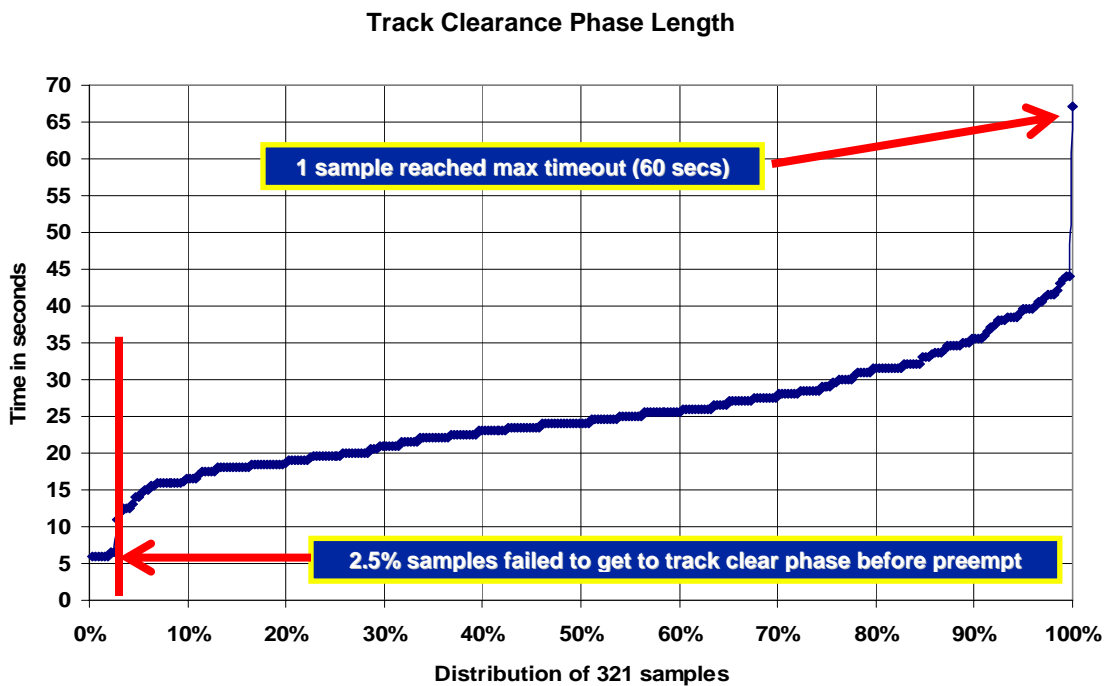

Figure 35. Track Clearance Phase Length Prior to Train.

One train sample created a situation where the controller held the track clearance phase for the maximum. This situation is indicative of a train that is inbound toward the intersection at decision time but stops before the intersection, thus not activating the

preemption. The NVAP Type – 1 system waits for the train arrival up to a maximum time, which is the case here. A significant delay to the main lanes is caused in this case.

Extended track clearance times cannot be effectively controlled using the NVAP Type – 1 strategy. The technique does not have knowledge of how long the pedestrian phase has been active and thus cannot adjust the time when the low-level preempt is issued. For example, if the pedestrian phase has been active for longer than the minimum clearance time, the controller can immediately end the phase and move to track clearance where it will dwell until the rail preempt is issued. This dwell time can be as long as the decision to preemption time.

NVAP Type – 2 Results

The NVAP Type – 2 strategy was also implemented at the Holleman Drive intersection. This technique makes a choice to drop a pedestrian phase if train arrival estimates indicate the rail preemption will truncate the phase. The window in which the choice is made (window of opportunity) is 22 to 24 seconds before expected rail preemption. The NVAP Type – 2 system was operated at the intersection and data collected for 167 train movements. Of the 167 movements, 119 movements (71 percent) generated a pedestrian omit. With the system in place, 15 percent of the train samples encountered a truncation of the pedestrian phase. The pedestrian phase was called outside the window of opportunity therefore the NVAP Type – 2 algorithm was unable to influence the controller’s decisions. The remaining 14 percent of the train samples did not generate a phase omit but did meet the pedestrian phase minimums. [Table 16](#) summarizes the results.

Table 16. Summary of NVAP Type – 2 Results.

Action	Samples
Pedestrian phase omit issued by NVAP	71%
Pedestrian phase truncations	15%
No omit / no truncation	14%

ALICE TESTBED

The test location for the preemption-based train detection NVAP system was Alice, Texas. Alice was chosen for several reasons. The SH44 / SH359 corridor is a primary east-west corridor through Alice and has a nearby parallel Kansas City Southern (KCS) Railroad line. The corridor has several closely spaced preempted grade crossings which will be used for train tracking data. Finally, the corridor received a recent upgrade in traffic signal control hardware including video detection and TS 2 traffic signal cabinets. Figure 36 shows the corridor.

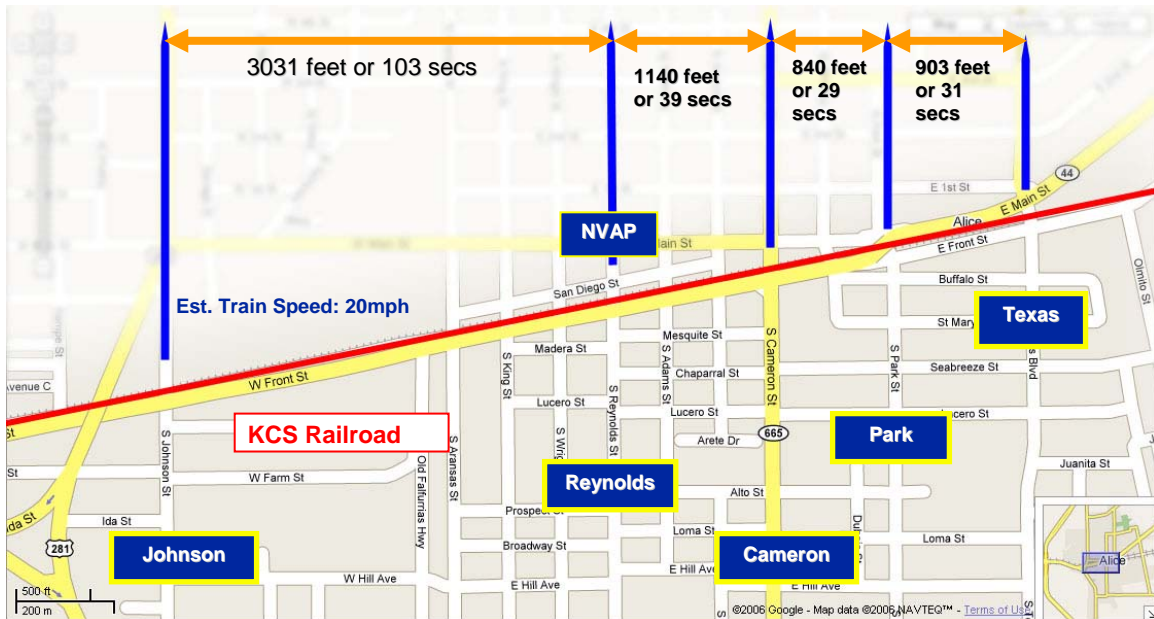

Figure 36. Alice, Texas, Deployment.

The following preempted intersections were selected for use in the research: Johnson, Reynolds, Cameron, Park, and Texas. Each of the intersections includes a simultaneous rail preempt which was used for train detection. Reynolds, which is located near the midpoint of the corridor, was selected to host the NVAP system. Figure 37 shows the Reynolds Street intersection and grade crossing.

Observations of trains in the corridor indicated an average train speed of approximately 20 miles per hour. Given the flat topography and the central urban setting, the speed is expected to be fairly constant throughout the corridor. Looking at the

distances between intersections, estimates of travel time can be generated and are shown in [Table 17](#).



Figure 37. Reynolds Street NVAP System Location.

The travel times are simple calculations based on a constant speed over a known distance. Additionally, each of the intersections has simultaneous preemption and should start approximately 25 seconds prior to actual train arrival. Since all the intersections are simultaneous preemption, the time between preempts at the intersections is also the travel time between intersections (each intersection starts 25 seconds prior to the arrival of the train).

Table 17. Estimated Train Travel Times (in seconds) between Locations.

From / To at 20 mph	Johnson	Reynolds	Cameron	Park	Texas
Johnson	0	103	142	171	202
Reynolds	103	0	39	68	99
Cameron	142	39	0	29	60
Park	171	68	29	0	31
Texas	202	103	60	31	0

Many of the TxDOT-maintained signalized intersections in Alice have been outfitted with a communication system to allow remote management by TxDOT staff from their offices in Corpus Christi. The system is a traditional signal interconnect system using a master intersection with a dial-up connection to Corpus Christi and a local area wireless link to the included intersections in Alice. Each intersection can be

interrogated from Corpus Christi. The NVAP project required communication among each of the test intersections along the rail corridor. One option was to deploy a totally stand-alone solution that provided the needed service. A second option was to develop a method to piggyback on the already operational intersection communication solution. This option would deliver significant savings in both equipment costs and installation time and effort. [Appendix C](#) summarizes the piggyback communication solution that was designed and deployed. The solution provided all the needed service and proved to be a convenient option.

Each of the five intersections received an NVAP-RC that monitored and broadcast the status of the intersection’s preempt. The Reynolds intersection received the full NVAP system including the equipment to issue non-rail low-level preempts. Researchers installed and tested the system in the summer of 2007. After several days of data collection several critical issues began to emerge concerning the railroad-maintained preemption at the intersections. First, all the intersections experienced a significant number of false preemptions — preemptions when a train was not in the area. A few of the intersections saw a large number of these false preemptions. [Figure 38](#) shows a comparison of total preemptions and those that can be attributed to trains.

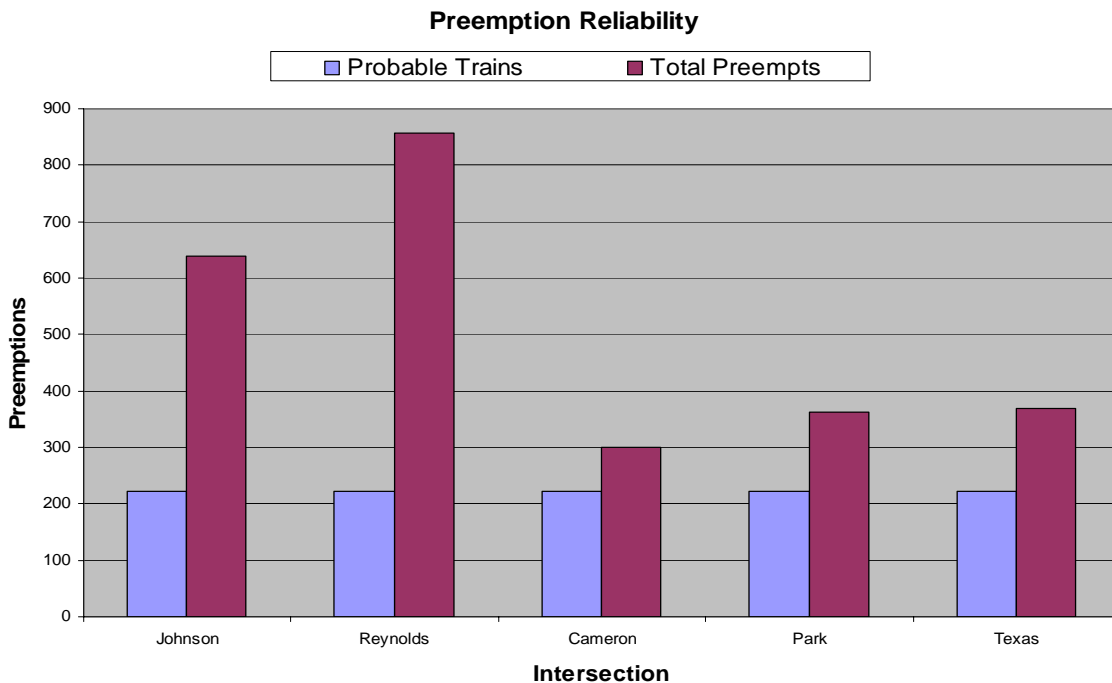

Figure 38. Preemption Reliability.

Preemptions were defined as probable trains if preemptions from other intersections in the corridor were seen within a reasonable timeframe. Given the data, the Johnson intersection had approximately 35 percent of its preemptions classified as probable trains. Reynolds was even worse with 26 percent classified as probable train. The remaining locations are better but still problematic with Cameron at 74 percent, Park at 62 percent, and Texas at 60 percent. This false alarm rate is very high and would be catastrophic on any NVAP system by initiating action at Reynolds for phantom trains.

Another issue associated with rail preemption became apparent. In a significant number of occasions, preemption started very early or out of sequence at some of the sites. For example, consider a westbound train traveling through the corridor from Texas toward Johnson. In numerous cases an intersection further downfield than the next intersection would start before the next intersection. Following the example, preemption would be seen at Texas and the next preempt may be seen at Cameron followed shortly by a preemption at Park. In this example, the preemption at Cameron started ahead of Park and the NVAP system would perceive the data as the train being at Cameron when it was actually near Park. Out of sequence preemption strongly impacts the quality of train predictions. A similar issue was also observed where a rail preempt would activate then release just a few seconds later and finally activate again closer to the appropriate time. Given these issues it was decided to not send NVAP-generated low-level preempt indications to the traffic signal controller at Reynolds. Many long phase cycles induced by the NVAP without a train would cause undue risk.

In an effort to gain some insight from the Alice experience, NVAP train detection data were collected for a period of approximately one month. The data were then manually cleaned of apparent false preemptions to yield a dataset which would better represent train movements in the corridor. [Figure 39](#) shows travel times based on preemption for 114 trains between Reynolds and the other intersections.

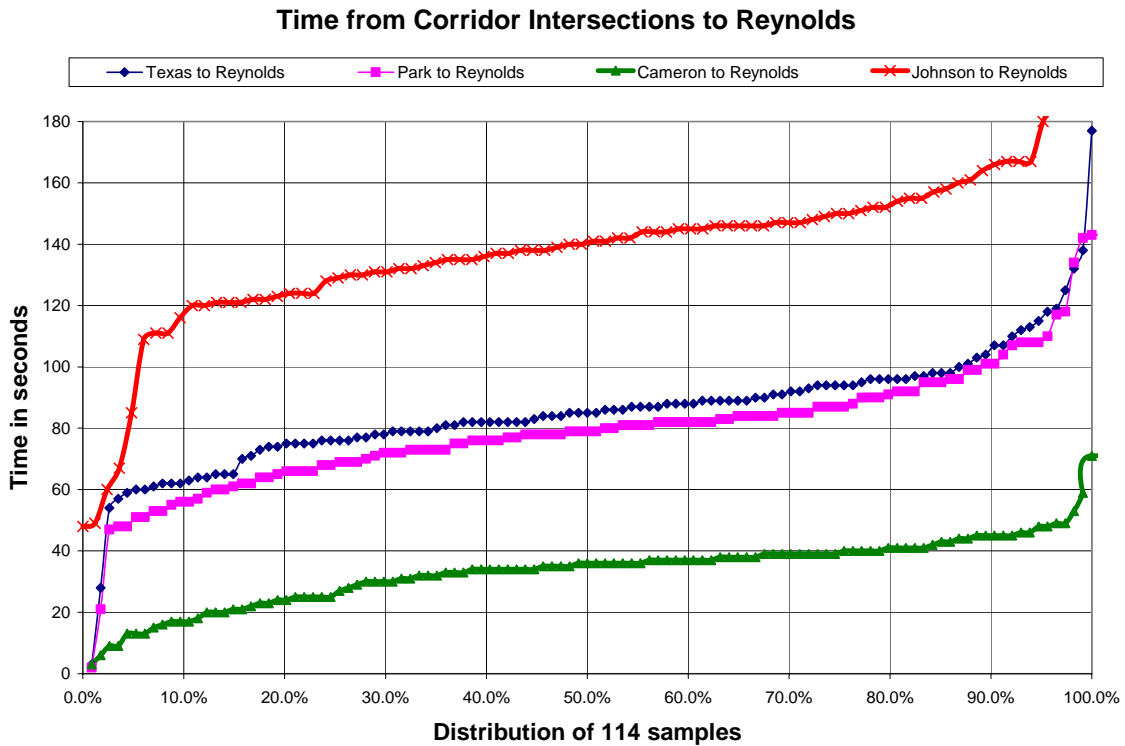

Figure 39. Travel Time from Corridor Intersections to Reynolds Street.

Figure 39 plots the distribution of arrival times from each intersection in the corridor to Reynolds based on preempt starts. Looking at the distribution of travel times between Johnson and Reynolds (top most line), the average (mean) value is 140 seconds. The mean calculation does not include the outliers near either end of the spectrum (i.e., clipping off 5 percent from the low numbers and high numbers). Also note the slope is not as flat around the mean as in the College Station case. This slope indicates fewer arrival times concentrated around the average that is not beneficial for any system using the data. The plots do show the slope is closer to the horizontal for intersections near Reynolds and slightly increases for intersections moving away from Reynolds (distances growing). Table 18 shows travel time probabilities for intervals around the mean as in the previous College Station case. The table also includes an average speed in miles per hour calculation for the different travel segments.

Table 18. Distribution of Travel Times around the Mean for Alice Deployment.

Metrics	Johnson to Reynolds	Cameron to Reynolds	Park to Reynolds	Texas to Reynolds
Mean	140 seconds	38 seconds	79 seconds	85 seconds
Standard Deviation	14.1 seconds	8.8 seconds	14.8 seconds	13.8 seconds
± 2 seconds of mean	11% of samples	30% of samples	13% of samples	12% of samples
± 5 seconds of mean	25% of samples	50% of samples	32% of samples	32% of samples
± 10 seconds of mean	49% of samples	69% of samples	51% of samples	57% of samples
Average speed	15 mph	21 mph	17 mph	23 mph

Looking at the average speeds first, variability is quite evident in different segment averages. The Johnson to Reynolds link is 5 mph slower than our original design estimate of 20 mph. Cameron to Reynolds, the shortest length segment, is very close with 21 mph average speed. Park to Reynolds dips below the Cameron to Reynolds number by 4 mph which appears suspect. There is little reason for the Park and Cameron numbers to vary since they are closely spaced intersections. A reasonable explanation, based on observation and the total dataset, is the difference in average speed is produced by the variability in start times for the rail preempt at these intersections. Texas to Reynolds posted the highest average speed at 23 mph. The mean times for Park and Texas are only 6 seconds apart yet the average travel time is 5 mph different. Again, this result appears suspect and may well be attributed to inconsistent preemption starts at these locations. Another possibility is that trains are slowing down as they pass between Texas and Park. There is no way of truly determining the cause with the dataset that was captured. It is clear that choosing a single average speed for the corridor is problematic and will lead to poor train arrival estimates for the NVAP system. The NVAP system could adjust to variability in average travel times by maintaining a database of past travel times and continuously adjusting the travel time in the algorithm to match the historic average.

Turning to the consistency of the travel times, the best probabilities should be linked with the Cameron to Reynolds numbers because the travel distance is the least. For this segment, there is only a 50 percent probability of predicting the travel time

within five seconds. The probability expands to 69 percent for a travel time estimate within 10 seconds of the average. Given that Cameron and Reynolds are closely spaced (1140 feet), this time distribution is as good as the system can get yet significant variability remains. The variability is likely too high to support an efficient NVAP.

The travel times from further away intersections appear to fit into a pattern. The probability of a train arrival estimate within two seconds of average is in the low teens or very unlikely. The probability of an estimate being within five seconds moves up to the high twenties and low thirties, still unlikely. An estimate being within 10 seconds increases to approximately 50 percent. In general, predictions using preemption in this corridor are unreliable, even for a close intersection.

CHAPTER 6: CONCLUSION AND RECOMMENDATIONS

This research project experimented with the concept of non-vital advance preemption (NVAP). The NVAP would be a potential safety enhancement overlay for active grade crossings near signalized intersections. These intersections receive a preempt signal from the railroad which alerts the traffic signal controller to the impending arrival of a train and more specifically to the closure of the roadway by a lowered crossing gate. The intersection has to ensure vehicles and pedestrians are treated safely during the transition from intersection normal operation to operation in advance of a train. A simultaneous preemption from the railroad equipment provides a minimum of 20 seconds advance notice of the arrival of the train and simultaneous notification of the activation of the lights and gates. The solution grants the traffic controller a minimum amount of time to safely manage vehicles and pedestrians. Railroad-supplied advance preemption provides more time but the costs are high and may not be fully warranted by the specifics of the intersection. The NVAP system is envisioned to provide a similar advance warning like the advance preempt but at a much lower cost and with equipment deployed solely on public right of way. The extra notification time supplied by the NVAP system could be used to better manage pedestrians by trying to ensure a minimum pedestrian phase (NVAP Type – 1) or by eliminating it altogether in advance of a train (NVAP Type – 2).

The research investigated two methods for train detection. The first method utilized microwave radar installed upstream and downstream of the target intersection where the NVAP will be used. The solution reused products from past TxDOT-sponsored research although the products are not ‘off the shelf’ items. The second option was to use preemption signals from other intersections in a corridor to track to the progress of the train. This option was attractive because it required no extra equipment installed along the right of way; instead, it leveraged the value of current intersection investments.

Train arrival estimates are the central element on which the NVAP system operates. These estimates need to be as accurate as possible. Data gathered from the College Station radar system and the Alice preemption system testing clearly show the

value of using a technique which can track and update (radar) itself over a simpler find and project solution (preemption). Table 19 summarizes the findings on the reliability of arrival time predictions of the two techniques.

Table 19. Summary of Prediction Probability.

	Radar-based predictions		Preemption-based predictions			
Mean time	34 sec	40 sec	38 sec	79 sec	85 sec	140 sec
Standard Deviation	4.7 sec	5.5 sec	14.1 sec	8.8 sec	14.8 sec	13.8 sec
± 2 seconds of mean	44%	31%	30%	13%	12%	11%
± 5 seconds of mean	82%	59%	50%	32%	32%	25%
± 10 seconds of mean	96%	84%	69%	51%	57%	49%

The radar-based system clearly produced more reliable predictions. The system was able to predict the arrival of between 60 percent to 80 percent (approximately) of the trains within five seconds of actual using radar sensors placed more than 3500 feet away. The probability extends to as much as 96 percent for an interval of 10 seconds around the expected. The standard deviation for the radar system was consistently lower than the preemption system. In all but the close intersection case at Cameron with a standard deviation of 8.8 seconds, the radar system standard deviation is better than half that of the preemption solution.

The preemption only option does not compare well. Probabilities compare only if the distances between locations are short, as would be expected. As distances increase, the reliability suffers greatly as shown by the quickly increasing standard deviation. Looking at the 140-second mean case, the site (Johnson) was located approximately 3000 feet away from the target intersection (Reynolds). Using this case to compare to the radar option (radars were more than 3500 feet away), the value of the radar solution is easily seen. The radar system, at worst case, was able to post a 59 percent probability of predicting the arrival within 5 seconds of the expected while the preemption system was only able to yield at 25 percent probability.

The research shows that a significantly higher degree of accuracy is obtained from the radar-based train detection system. This solution should be used for NVAP strategies

that are sensitive to prediction variation. In the case of NVAP – Type 1, very long dwell times can occur in the track clearance phase which results in lower operational efficiency at the location. The preemption-based solution may be reasonable for detection situations where a much lower degree of accuracy is required. For example, the scheme may be appropriate for a project which takes a more macroscopic perspective on corridor operations. In this case the important aspects might be that a train is approaching an intersection and will arrive within a time period of 60 seconds. Precise decisions are not made using the train data, but rather the data are used as more general information describing the situation in the corridor.

In terms of enhancing pedestrian safety at signalized intersections, the research found that both the NVAP – Type 1 and NVAP – Type 2 strategies were able to reduce the number of times that the pedestrian clearance interval had to be truncated compared to when simultaneous preemption was used at the test intersections. NVAP – Type 1, which uses a second preemption to ensure that a full pedestrian clearance interval is provided in advance of the normal preemption sequence, provided adequate pedestrian clearance in almost every observed train event, but resulted in increased vehicle delays at the intersection. NVAP – Type 2 strategy, which uses Pedestrian Omits (a feature available in most NEMA type controllers) to skip the pedestrian phase altogether, resulted in fewer truncations of the pedestrian walk interval. Using the NVAP – Type 1 strategy also resulted in a 30-percent reduction in the number of times that the vehicle green interval had to be truncated during the preemption sequencing.

In terms of intersection operations, the NVAP – Type 1 strategy caused the average intersection delay to increase approximately 13 percent compared to when the other strategies were used at the test intersections. NVAP – Type 2 showed no appreciable increase in vehicle delays; however, one disadvantage of this strategy was the long time delay between activations of pedestrian walk intervals which could cause pedestrians at intersections to feel like they have been skipped and potentially cross when a “DON’T WALK” indication is active at the intersection. Neither type of NVAP strategy caused a significant change in the average queue lengths on the intersection approaches.

APPENDIX A: NON-VITAL ADVANCE PREEMPTION SYSTEM SPECIFICATION

A non-vital advance preemption system (NVAP) must provide advance information (information prior to preemption) regarding the impending arrival of a train at a simultaneous preempted highway-rail grade crossing for use by the highway traffic signal system. The advance information will be used to better position the traffic signal controller for the upcoming railroad preempt. This positioning should provide an increased level of safety and operation efficiency at the preempted intersection.

The NVAP is only to be used in conjunction with a normally preempted intersection. The NVAP, by design, is not a replacement for true railroad-provided preemption at a highway-rail grade crossing and should never be considered in such capacity. The NVAP is strictly to be considered a performance enhancing overlay on the fail safe, vital preemption indication from the railroad grade crossing controller.

The NVAP system should provide at minimum a data stream or signal for use by a traffic signal controller which will indicate an approaching train is at or less than a known amount of time away from the target grade crossing. This time should be configurable and provide at least 60 seconds advance warning. For example, the output from the NVAP system to a TS 1 traffic signal controller would follow the traditional traffic signaling technique of a dry contact which pulls a traffic signal controller input (such as a preempt) to a low voltage (call) condition. For a 2070 controller, a serial data stream could be provided from which the 2070 extracts the advance preemption information.

The NVAP system should follow the general design concept of the IEEE 1570-2002 standard entitled “*IEEE Standard for the Interface Between the Rail Subsystem and the Highway Subsystem at a Highway Rail Intersection*” (16) officially published in October 2002. The standard defines railroad system equipment, roadway system equipment and an interface between them. The document clearly defines groups of devices by the agencies responsible for their maintenance. For example, all railway and train sensing equipment as well as railway sensor processing functions lie within the railroad system. All traffic sensing and signal control functions reside on the roadway system. [Figure 40](#) shows the logical grouping of devices.

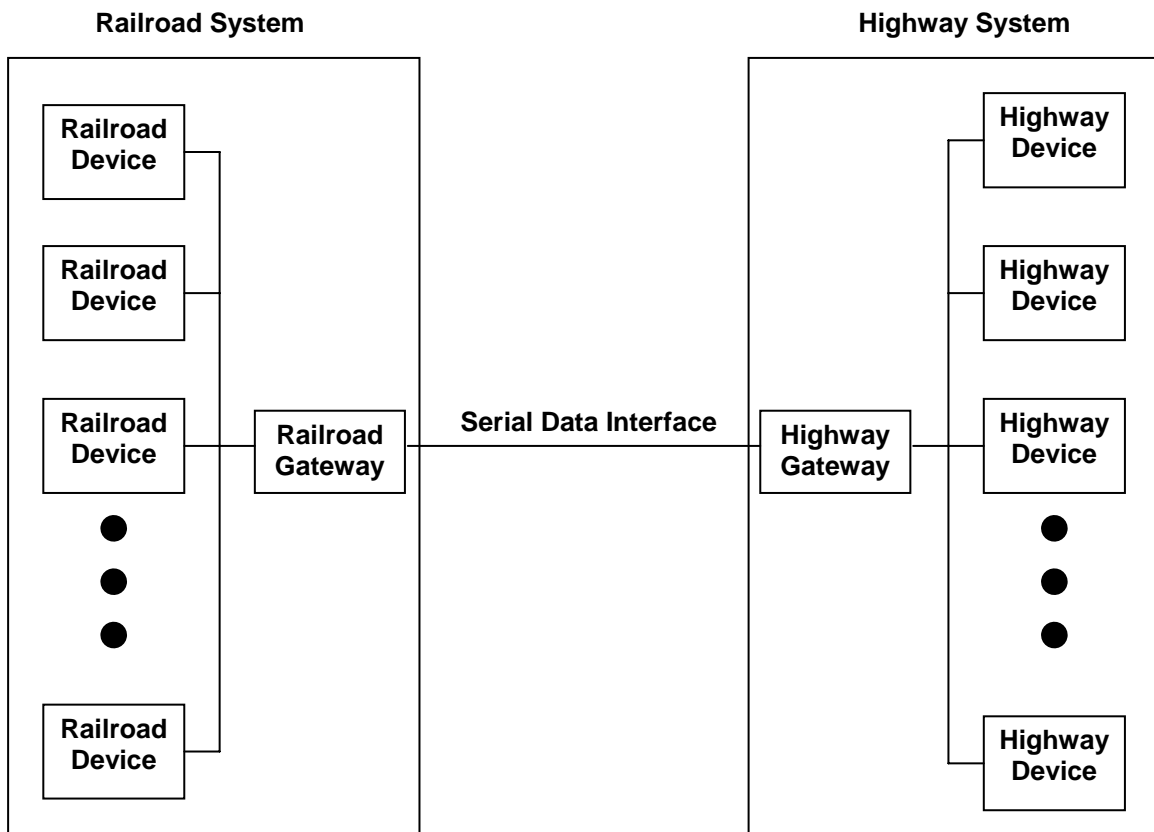

Figure 40. IEEE 1550-2002 Highway-Rail Intersection (HRI) Interface Architecture.

The NVAP system is envisioned to be comprised entirely of equipment installed and maintained by the roadway agency. All train or railway detection devices will be installed off right of way but will be considered to reside with the railroad system although the equipment will not be installed nor maintained by railroad personnel. Logically, the equipment provides the advance preempt function of railroad equipment if such equipment were deployed and thus should be classed as such. The railroad devices may communicate among themselves and with the railroad gateway. They will not communicate directly with highway devices. Communication between the railroad and highway systems is reserved for the respective gateways.

Gateways are defined for communication between the railroad system and the highway system. The railroad gateway is logically shown to reside within the railroad

system group and thus would be expected to physically reside in railroad-maintained housings. Since there will be no railroad specific housing (i.e., grade crossing bungalow), the gateway is likely to reside within the highway system.

A highway gateway is depicted as a unique box in the diagram in Figure 40. The functions of the highway gateway should be included but the contents of the box may physically reside in a highway device as shown in Figure 41. For example, a 2070 controller may receive the serial data interface stream directly and an internal software module would provide the gateway's logical functions.

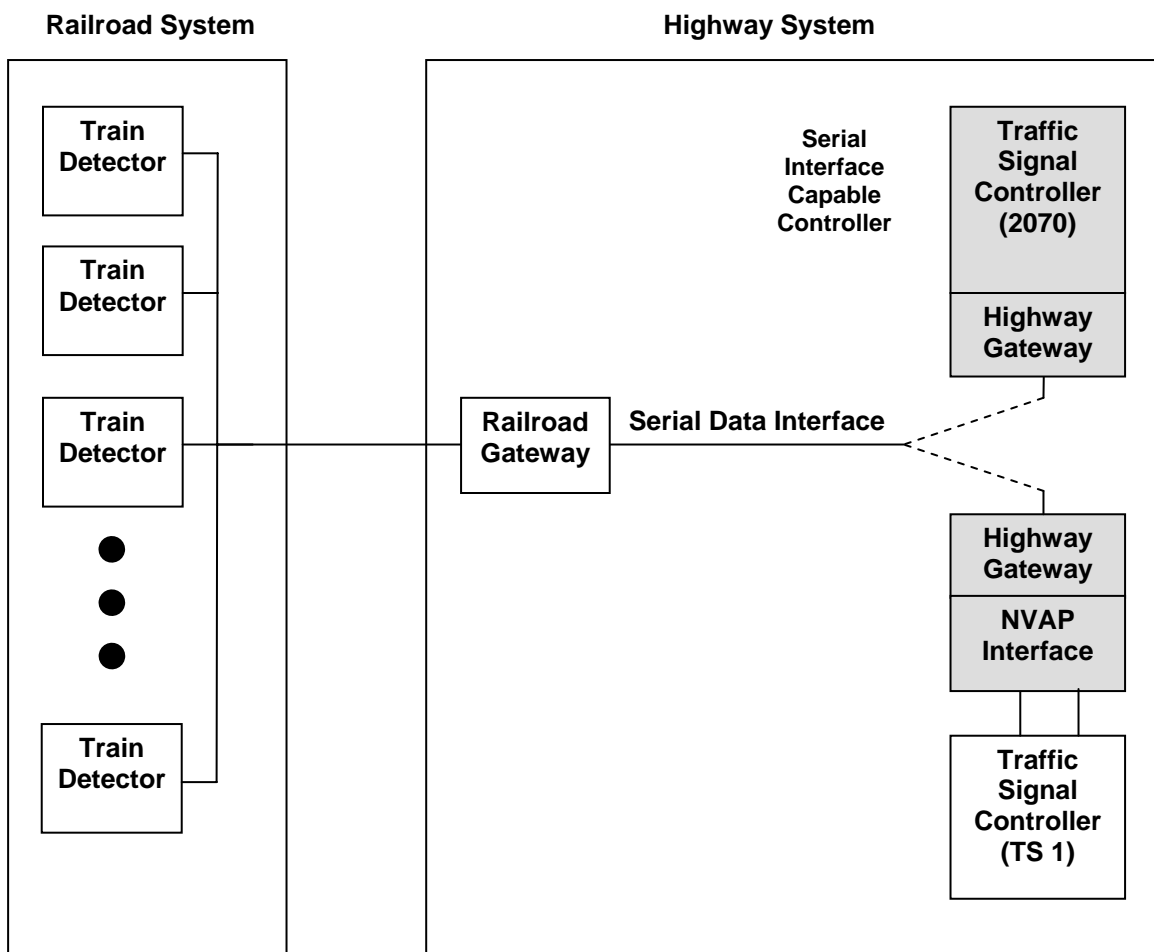

Figure 41. Off Right of Way NVAP Architecture.

A serial data interface between the two gateways shall be provided following the principles of the IEEE 1570-2002 standard although exact technical definitions and

procedures will not be required. Logical data elements identified in IEEE 1570-2002 should be used where prudent but exact technical adherence to areas such as data communication protocols will not be required. For example, conveying an estimated time of arrival should be included but the use of a binary message protocol is not required.

The NVAP system should provide at minimum a documented serial data interface which conveys the train's estimated time of arrival at the preempted grade crossing or estimated time to warning system start (following the IEEE 1550-2002 lead) where warning system start refers to the activation of lights and bells at the grade crossing. This item is included in the HRI Rail Crossing Operational State message defined in IEEE 1550-2002 (16). Actual preemption information, also included in the HRI Rail Crossing Operational State message, will not be required since it is already available via the current grade crossing interface.

The serial interface may include other beneficial information defined in other IEEE 1550-2002 messages such as train speed, length, direction, and anticipated departure or clear time, but they are not mandatory. The extra information, if provided, could be used in addition to the arrival time to develop a more complete picture of railroad activity in the region near the grade crossing and thus feed into a more intelligent advance preemption algorithm.

The NVAP interface logical box is envisioned to receive the serial data interface containing train information and any other inputs required (such as condition information from the traffic signal controller) and execute an algorithm which calculates when to deliver calls to the traffic signal controller to influence its operation in advance of the grade crossing activation and the arrival of the train. For the case of a TS 1 and TS 2 signal controller, the NVAP interface will likely be a stand-alone device since there is no capability to add software functionality to controllers themselves. A 2070 controller could support a software module that provides the capability of the NVAP interface internally.

APPENDIX B: IMPLEMENTATION GUIDELINES

The NVAP solution is not a solution for every corridor. The trains in the corridor must move through the area and not stop and start. The solution is also not suited for areas near railroad yards or switching locations (i.e., factories, distribution facilities, etc.). The back and forth movement will create numerous false train detections. An ideal corridor for the NVAP sees through train movements at or near a constant speed. As shown in the research, significant acceleration and deceleration is detrimental. If the corridor is at the edge of an urban area, or a point where posted track speed changes expect lower quality results. Long trains provide better results than short trains due to the fact that long trains are within view of the radar train sensor for an extended amount of time. Short trains are visible for less time and the NVAP system must rely on dead reasoning to project the train forward which can create significant error.

The radar-based NVAP requires the installation of two radar train detection stations, one upstream and one downstream of the target intersection. The detection stations are located off the railroad right of way and need to be placed at a distance that will yield a desired advance warning time plus some time to lock on and track the train. For this research, the detection stations needed to be placed at a minimum of 60 seconds (35 seconds ahead of preemption which occurs 25 seconds in advance of train arrival at the intersection) away from the target intersection (Holleman Drive). At a speed of 40 mph the distance would be 3520 feet and for a speed of 30 mph the distance would be 2640 feet. It is good practice to place the sensors a little further out so they can capture a good speed profile of the train. An additional 10 seconds is a good rule of thumb. Obviously knowledge of the average and peak train speeds is required to make final judgments on sensor placements. Acquiring this information may require some preliminary data collection in the field for assurance.

The radars need to be positioned with a clear view of the railroad track and with a minimal, if any, view of other moving objects. The radar will easily pick up objects moving in the background and they can be mistaken for a train. Installations with nearby roadways (adjacent to the railroad tracks) can be particularly difficult and require more precise aiming and fine tuning. The radar should be tilted toward the ground to limit its range.

Communication is vital for the NVAP system (both radar-based and the preemption-based) to operate effectively. Both train detection stations send continuous messages to the NVAP controller at the target intersection although the data rate does not have to be high. A communication system supporting 9600 baud is sufficient. As was shown in the research, the data may be piggybacked upon an already installed communication solution. One important point to note is the train detection stations are not designed to be polled. They transmit their messages periodically or on exception when events happen. This concept, peer-to-peer, may not be supported by some communication hardware sold in the transportation marketplace. For instance, a closed loop system is not peer-to-peer. A master polls each intersection. Intersections may not transmit out of turn. The communication system developed for the Alice, Texas portion of the research took this into account and used software to overcome the issue.

Calibrating the radar detection stations is very important and should be done carefully. The radar detector senses the component of an object's velocity that is directly in line with the sensor (i.e., parallel). The radar, when installed on a pole off the railroad right of way, will most likely not be directly in line with the railroad track. The result from the off angle placement is a lower than true speed reading. This speed differential must be accommodated in the station's calibration by adjusting a multiplier value to compensate for the skew angle.

A sample of train passages must be taken to use as a basis for selecting the proper multiplier value. It will be very difficult to try to match sensor detection speeds to actual train speeds at the site. Luckily it is much easier to do it after gathering data from a group of trains. Compare the NVAP system's arrival predictions to the time when preemption actually arrives. Modify the train detection station multiplier to tune the arrival estimates to match the measured preemption as closely as possible. There will always be variability; therefore, the calculations need to be made based on a set of trains — not just one or two.

When configuring the NVAP system, a reasonable 'max out' should be defined. There will be situations when a train is detected yet it is very slow to arrive at the intersection. An example case would be simply a false train detection made by one of the train detection stations or the detection of a train whose intention is to stop before the

intersection and wait. The train's actions may not trigger preemption and thus the NVAP system will provide its low-level preempt for an inordinate amount of time. At some point the NVAP must decide that the situation with the train has become unknown since it has not arrived at the intersection in a reasonable time period. The low-level preempt must be released.

The quality of a railroad's grade crossing detection system requires investigation before selecting a corridor for a deployment. In the College Station case, the railroad's train detection system (traditional track circuit) at Holleman Drive worked consistently well. The quality of the grade crossing activations in Alice would mask any benefits provided by an NVAP addition. The railroad maintains the grade crossing systems and, therefore, the highway authority has no control over their operation.

APPENDIX C: MULTIPLEXING NVAP DATA WITH AN INTERSECTION CLOSED LOOP CONTROL SYSTEM

The deployment of the preempt-based NVAP system in Alice, Texas, offered an excellent venue to explore the idea of multiplexing or piggybacking data from one system (NVAP) onto another (corridor closed loop system) with the goal of gaining additional use of the host’s communication infrastructure. TxDOT maintains a communication system touching many of the intersections in Alice, including the intersections along the railroad corridor. The closed loop system utilizes wireless communication to reach all the active intersections. The wireless network is designed as a multi-drop network with a single master. The radio master is located with the traffic signal control master. The traffic signal master manages all communication on the line using a request / response concept. Intersections are periodically polled by the master and are given a specific amount of time to respond. Intersections do not broadcast without a request from the master.

An analysis of the traffic signal control scheme revealed a substantial amount of free time available on the wireless network. In general, the traffic control master polls the intersections on an infrequent basis. In addition, the master polls all the intersections in a round robin fashion (one right behind another), thus leaving a large amount of quiet time between the end of the polling sequence and the beginning of the next cycle. [Figure 42](#) shows a typical polling cycle.

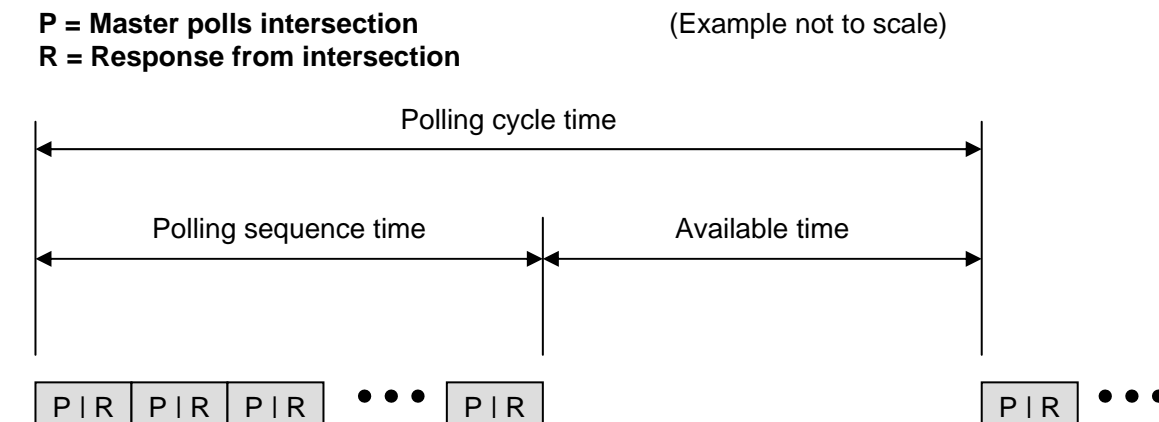

Figure 42. Poll / Response Cycle for Intersection Control.

The quiet time (available time) shown in [Figure 42](#) is typically much larger than the polling sequence time and could easily be as large as 85 percent of the polling cycle time. The true value is determined by the number of intersections being polled. The available cycle time after the polling sequence can be utilized by other devices. Other devices can listen to the communication between master and intersection and hold their communication until the master / intersection polling sequence is complete. Once a gap is found where the master has completed polling intersections, the external devices, in this case the NVAP-RC, send messages.

This solution is effective for low-priority messages, messages which can be held in a queue until the gap arrives. Most of the messages flowing among the NVAP-RCs are low-priority heartbeat-type communications simply reporting no change but verifying an operational device and communication link. These messages can wait but a message that conveys the beginning of preemption and subsequent TSP information will need to be transmitted more expeditiously. These higher-priority messages can be forced into the polling sequence time and will be filtered out by the traffic equipment because they do not conform to the traffic management system protocol and error checking technique. Similarly, the traffic management system message will be filtered by the NVAP-RC for the same reasons. In general, the traffic system will filter out the NVAP messages due to non-conformance to their rules and the traffic system messages will be filtered out by the NVAP system for non-conformance.

One method to physically multiplex the two different devices to a single communication medium would be to use a terminal server that manages individual communication on each port. The terminal server creates and sends copies of input from one channel into other channels on the device. Think of the device as a large configurable switch where inbound content on each port can be mapped to a mixture of the other ports. Applying the terminal server as a site communication manager, a field cabinet design evolves, as shown in [Figure 43](#). The components to integrate in the cabinet are the traffic signal controller, the NVAP-RC, and the traffic signal system interconnect radio. Typically all these devices support an RS-232 interface which is easily accepted by the terminal server. [Table 20](#) describes the terminal server port assignment for a four-port device, of which only three are used. Analyzing the configuration, a copy of

inbound data on port 1 is sent to port 2 and port 3. Copies of inbound data on port 2 are sent to port 1 and port 3. Finally, inbound data on port 3 are copied to port 1 and port 2.

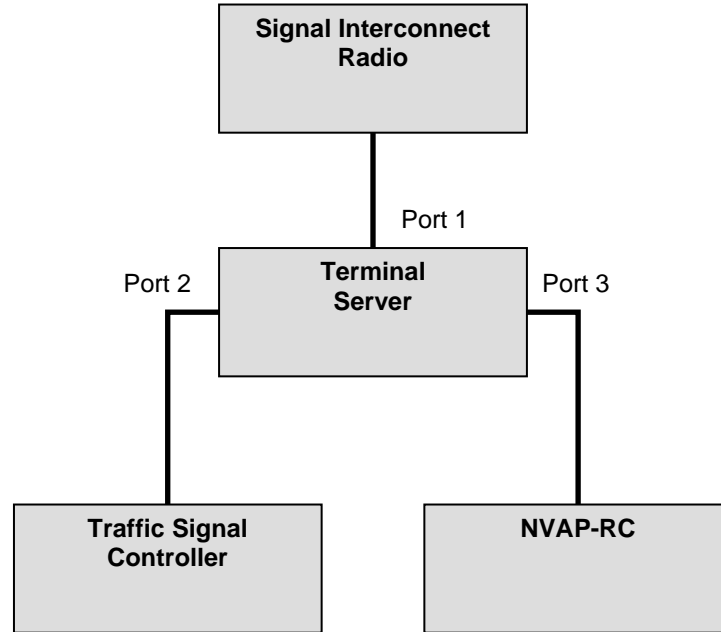

Figure 43. Cabinet Layout Utilizing Terminal Server.

Table 20. Terminal Server Port Assignment Matrix.

Terminal Server Port Assignment Matrix		Outbound			
		Port 1	Port 2	Port 3	Port 4
Inbound	Port 1		X	X	
	Port 2	X		X	
	Port 3	X			
	Port 4				

The site’s radio is the interface to the network. Inbound data are sent to both the traffic signal controller and the NVAP-RC. The traffic signal controller will filter out the data from other NVAP-RCs but will accept commands from the signal system master. Similarly, the NVAP-RC receives a copy of all inbound data from the radio and disregards the traffic signal control commands but does monitor the stream for gaps. The NVAP-RC will transmit its messages on gaps in inbound data traffic. The traffic signal

controller data output is routed to the radio and to the local NVAP-RC which expects to hear it respond to master control. Finally, the data outbound from the NVAP-RC are routed only to the radio and not to the local traffic signal controller. The signal controller has no need to hear the NVAP-RC since it will simply disregard the transmission.

The solution as described was deployed in Alice to avoid the extra costs, time, and effort to install a secondary corridor communication system to support the NVAP project. The deployment proved the concept and worked admirably during the testing and data collection effort in Alice. Based on the success, the solution should be considered for other projects requiring a simple communication solution where a closed loop system already exists.

APPENDIX D: NVAP-APPROACHING TRAIN INFORMATION (NVAP-ATI) MESSAGE DEFINITION

The NVAP-Approaching Train Information Message is encoded as comma delimited ASCII string followed by a carriage return and line feed to mark the end of the frame. The message is used in the radar-based train detection design utilized in the College Station deployment. Data elements (fields) are included to provide extra information which can be useful for a more elaborate version of the NVAP solution or by other applications. Not all of the information provided in this message is required to successfully operate an NVAP system. In the conducted research, the only field truly required was the estimated time of arrival. The other data were used extensively for troubleshooting and error detection.

The NVAP-ATI message is transmitted once per second at a rate of 9600 baud.

The fields within the NVAP-ATI message frame are defined as:

Field Name: MESSAGE_SEQUENCE_NUM
Field Range: 0 to 255
Description: Message identification. The sequence number is incremented for each new message and rolls over to 0 after 255.

Field Name: ESTIMATED_TIME_OF_ARRIVAL
Field Range: -1 to 999
Description: Number of seconds in which the front of the train is expected to arrive in the intersection. Note: this is not the number of seconds before preemption is expected. A value of -1 indicates the front of the train has been projected past the intersection.

Field Name: ESTIMATED_TIME_OF_DEPARTURE
Field Range: -1 to 999
Description: Number of seconds in which the rear of the train is expected to arrive in the intersection. A value of -1 indicates the rear of the train has been projected past the intersection.

Field Name: ESTIMATED_SPEED
Field Range: 0.0 to 99.9
Description: Speed in miles per hour the train is expected to be moving.

Field Name: ESTIMATED_TRAIN_LENGTH
Field Range: 0 to 9999
Description: Estimated length of the oncoming train measured in feet.

Field Name: DIRECTION
Field Range: 0 or 1

Description: Direction of train in the corridor. For instance, 0 may represent north and 1 may represent south.

Field Name: PREEMPT_STATUS

Field Range: 0 or 1

Description: 0 represents the preemption active state (preempt call on the controller). 1 represents no call or crossing gates inactive.

Field Name: SYSTEM_HEALTH

Field Range: 0 to 255

Description: An indication of detected problems within the NVAP train detection and NVAP-RC system.

0: System inoperative

1: Health unknown

2: Loss of communication with train detection stations

3: Train detection station reporting problems

4: Train detection station not updating reports

5: High noise at a train detection station

101: Long time since a train has been detected at north sensor

102: Long time since a train has been detected at south sensor

Field Name: NORTH_SENSOR_BACKGROUND

Field Range: 0 to 100

Description: An indication of the background noise intensity at a sensor location.

Field Name: SOUTH_SENSOR_BACKGROUND

Field Range: 0 to 100

Description: An indication of the background noise intensity at a sensor location.

Field Name: SYSTEM_CONFIDENCE

Field Range: 0 to 9

Description: 0: No confidence in train predictions

1: System resetting

5: No train detected and conditions and all systems operational

7: Train predictions created by dead reasoning due to a gap in data from train detection sensors

8: Train predictions delivered via communication from train detection stations

9: Train detected at sensor but no prediction available

Field Name: TIME_SINCE_LAST_TRAIN

Field Range: 0 to 2,147,483,647

Description: The number of seconds since the last train was projected past the intersection

Field Name: DIRECTION_LAST_TRAIN

Field Range: 0 or 1

Description: 0 represents northbound and 1 represents southbound

APPENDIX E: NVAP-SIMPLIFIED ATI (NVAP-SATI) MESSAGE DEFINITION

The NVAP-Simplified Approaching Train Information Message is encoded as comma delimited ASCII string followed by a carriage return and line feed to mark the end of the frame. The asterisks character “*” leads off a data frame and is used as a start of frame marker. The message is used for the preemption-based train detection design utilized in the Alice, Texas deployment. The only required data element (field) is the estimated time of arrival. Other fields are included to support troubleshooting and error detection.

The NVAP-SATI message is transmitted once per second at a rate of 9600 baud.

The fields within the NVAP-ATI message frame are defined as:

Field Name: ESTIMATED_TIME_OF_ARRIVAL

Field Range: -1 to 999

Description: Number of seconds in which the front of the train is expected to arrive in the intersection. Note: this is not the number of seconds before preemption is expected. A value of -1 indicates the front of the train has been projected past the intersection.

Field Name: TIME_SINCE_LAST_COMM_FROM_NORTH_INTERSECTION

Field Range: 0 to 999

Description: Number of seconds since the last time a message frame has been received from the next intersection north. The message is used to determine if the location is offline.

Field Name: TIME_SINCE_LAST_COMM_FROM_SOUTH_INTERSECTION

Field Range: 0 to 999

Description: Number of seconds since the last time a message frame has been received from the next intersection south. The message is used to determine if the location is offline.

Field Name: TIME_SINCE_LAST_PREEMPT_FROM_NORTH_INTERSECTION

Field Range: 0 to 999

Description: Number of seconds since the last time a preempt has been detected from the next intersection north.

Field Name: TIME_SINCE_LAST_PREEMPT_FROM_SOUTH_INTERSECTION

Field Range: 0 to 999

Description: Number of seconds since the last time preemption has been detected from the next intersection south.

REFERENCES

1. Federal Highway Administration. *Manual on Uniform Traffic Control Devices*. Millennium Edition. U.S. Department of Transportation, Washington, D.C., December 2000.
2. American Railway Engineering and Maintenance of Way Association. *Communications & Signals Manual*. Landover, MD, 2002.
3. United States. *Code of Federal Regulations*. Subtitle B, Chapter II, Section 49, Part 234.225. Government Printing Office, Washington, D.C., 1998.
4. Highway/Rail Grade Crossing Technical Working Group. *Guidance on Traffic Control Devices at Highway-Rail Grade Crossings*. U.S. Department of Transportation, Federal Highway Administration, Washington, D.C., November 2002. <http://safety.fhwa.dot.gov/media/twgreport.htm>. Accessed March 12, 2003.
5. Institute of Transportation Engineers, Traffic Engineering Council Committee 4M-35. *Preemption of Traffic Signals at or Near Railroad Grade Crossings with Active Warning Devices*. Washington, D.C., 1997.
6. Institute of Transportation Engineers. *Preemption of Traffic Signals Near Railroad Grade Crossings*. Draft Version 7 (Unpublished), January 2003.
7. Tustin, H., H. Richards, H. McGee, and R. Patterson. *Railroad-Highway Grade Crossing Handbook*. Second Edition, Report FHWA-TS-86-275. U.S. Department of Transportation, Federal Highway Administration, Washington, D.C., September 1986.
8. Southwest Research Institute. *Railroad Delay Advance Warning System (Advance Warning To Avoid Railroad Delays) (AWARD) Model Deployment Initiative System Design Document*. Version 1.0. San Antonio, TX, March 1998.
9. Ruback, L. *TTI Center Tests New Train Detection Technique*. In Texas Transportation Researcher Volume 35, Number 2. College Station, TX, 1999. <http://tti.tamu.edu/researcher/v35n2/detection.stm>. Accessed March 13, 2003.
10. SRF Consulting Group. *Moorhead Area Integrated Train Detection and Traffic Control System*. Minnesota Department of Transportation, Minneapolis, MN, December 2000. <http://www.dot.state.mn.us/guidestar/pdf/moorhead1.pdf>. Accessed March 13, 2003.
11. Field, J.L. *North Carolina Innovative Traffic Control Field Experiment of the EVA Signal System*. Bi-annual Report # 2 and # 3, North Carolina Department of Transportation, Raleigh, NC, June 2002. <http://www.bytrain.org/safety/technology/eva602.html>. Accessed March 15, 2003.

12. Engelbrecht, R.J. *A Safety Checklist for Traffic Signal Operations Near Highway-Railroad Grade Crossings*. Proceedings of the 2002 Annual Meeting of the Institute of Transportation Engineers (CD-ROM), Washington, D.C., August 2002.
13. Federal Highway Administration. *Manual on Uniform Traffic Control Devices*. U.S. Department of Transportation, Washington, D.C., 1988.
14. Federal Railroad Administration. *School Bus Safety Alert*.
<http://www.fra.dot.gov/downloads/safety/busalert/busalert2.pdf>. Accessed March 12, 2007.
15. Federal Railroad Administration. *Truck Driver Safety Alert*.
<http://www.fra.dot.gov/downloads/safety/advisories/truckalert.pdf>. Accessed March 11, 2007.
16. Institute of Electrical and Electronics Engineers. *IEEE Standard for the Interface Between the Rail Subsystem and the Highway Subsystem at a Highway Rail Intersection*. Standard 1570. New York, NY, October 2002.
17. Texas Transportation Institute. *TransLink[®] Train Monitoring Project*.
<http://railview.tamu.edu/>. Accessed March 13, 2007.
18. Econolite Control Products. *Autoscope Solo Pro Machine Vision Processor*.
http://www.econolite.com/docs/autoscope/autoscope_soloproII_data_sheet.pdf. Accessed March 13, 2007.
19. EVA Signal Corporation. *Wireless Off-Track Train Detection System*.
http://www.evasignal.com/wireless_detectionsystem.htm. Accessed March 13, 2003.
20. Seitz, C.G., S.K. Sharon, and J.J. Hanson. *Highway Grade Crossing Off-Track Train Detection System*. Preprint CD-ROM of the Transportation Research Board 80th Annual Meeting, Washington, D.C., January 2001.
21. Korve, H.W. *Traffic Signal Operations Near Highway-Rail Grade Crossings*. NCHRP Synthesis of Highway Practice 271, Transportation Research Board, National Research Council, Washington, D.C., 1999.
22. Engelbrecht, R.J. *The Effect of Variation in Railroad Warning Time on Traffic Signal Preemption*. Proceedings of the Sixth International Symposium on Railroad-Highway Grade Crossing Research and Safety. University of Tennessee Center for Transportation Research. Knoxville, TN, November 2001, pp. 153-171
23. National Electrical Manufacturers Association. *Traffic Controller Assemblies*. NEMA Standards Publication No. TS 1-1989. Washington, D.C., 1989.
24. National Electrical Manufacturers Association. *Traffic Controller Assemblies*. NEMA Standards Publication No. TS 2-1992. Washington, D.C., 1992.
25. California Department of Transportation. *Transportation Electrical Equipment Specifications (TEES)*. Sacramento, CA, March 1997.

26. Oregon Department of Transportation. *Traffic Signal Policy and Guidelines*. Salem, OR, November 1999.
<http://www.odot.state.or.us/traffic/PDF/Signals/SigPol99PDF.pdf>. Accessed March 13, 2003.
27. PTV America, Inc. Website. <http://ptvamerica.com/vissim.html>. Accessed March 28, 2007.
28. Venglar, S., M. Jacobson, and R. Engelbrecht. *Enhanced Algorithm for Railroad Preemption of Traffic Signals*. Compendium of Papers of the 70th Annual Meeting of the Institute of Transportation Engineers (CD-ROM), Institute of Transportation Engineers, Washington, D.C., 2000.
29. Zhang, L. *Optimizing Traffic Network Signals Around Railroad Crossings*. Ph.D. Dissertation. Virginia Polytechnic Institute and State University, Blacksburg, VA, 2000. <http://scholar.lib.vt.edu/theses/available/etd-05172000-13150029/>. Accessed March 15, 2003.
30. Ruback, L. and Balke, K. *Integrating Train Information for Advanced Transportation Management*. Report 1752-7, Texas Transportation Institute, College Station, TX, March 2001.

