

1. Report No. FHWA/TX-04/0-4565-1		2. Government Accession No.		3. Recipient's Catalog No.	
4. Title and Subtitle ENHANCING INTERMODAL SERVICE THROUGH PUBLIC-PRIVATE PARTNERSHIPS IN TEXAS				5. Report Date October 2003	
				6. Performing Organization Code	
7. Author(s) Stephen S. Roop, Jeffery E. Warner, Craig E. Roco, Curtis A. Morgan, David H. Bierling, Juan Carlos Villa, Sarod P. Dhuru, and Chad J. Zorn				8. Performing Organization Report No. Report 0-4565-1	
9. Performing Organization Name and Address Texas Transportation Institute The Texas A&M University System College Station, Texas 77843-3135				10. Work Unit No. (TRAVIS)	
				11. Contract or Grant No. Project No. 0-4565	
12. Sponsoring Agency Name and Address Texas Department of Transportation Research and Technology Implementation Office P. O. Box 5080 Austin Texas 78763-5080				13. Type of Report and Period Covered Research: September 2002 – August 2003	
				14. Sponsoring Agency Code	
15. Supplementary Notes Performed in cooperation with the Texas Department of Transportation and the U.S. Department of Transportation, Federal Highway Administration. Project Title: Public-Private Partnerships for Enhanced Intermodal Rail Service in Texas					
16. Abstract <p>The increasing levels of truck traffic on the State's highway system are creating an array of issues for the Texas Department of Transportation ranging from highway safety, congestion, and air quality, to the need for accelerated maintenance and capacity expansion. With trade in Texas projected to continue to increase, the pressure to explore alternatives to highway-borne freight is building. At the same time, railroads are facing challenges of their own. As a capital- and labor-intensive industry, railroads are struggling to earn the cost of capital to maintain and operate their extensive networks. As a mode that excels at long-haul intercity freight, but loses to trucking in shorter-haul movements, railroads are in need of services and capital to help gain back lost market share and compete in short-haul markets.</p> <p>The opportunity for establishing a win-win scenario is apparent: by improving the efficiency of intermodal rail service through targeted public-private partnerships, rail transportation may capture a larger market share of intercity freight in Texas and allow important public benefits to accrue – thereby justifying the investment. This report provides an important step in synchronizing public and private transportation planning and financing processes that mostly operate in isolation from one another to the growing disadvantage of each. A truly exciting finding is that both the public sector and the railroads are increasingly receptive to the idea of collaboration and are searching for mutually beneficial solutions to transportation problems.</p>					
17. Key Words Intermodal Freight, Public-Private Partnerships, Short-Haul Intermodal, Transportation Economics, Multimodal Freight			18. Distribution Statement No restrictions. This document is available to the public through NTIS: National Technical Information Service 5285 Port Royal Road Springfield, Virginia 22161		
19. Security Classif.(of this report) Unclassified		20. Security Classif.(of this page) Unclassified		21. No. of Pages 144	22. Price



**ENHANCING INTERMODAL SERVICE THROUGH PUBLIC-PRIVATE  
PARTNERSHIPS IN TEXAS**

by

Stephen S. Roop  
Research Scientist  
Texas Transportation Institute

Jeffery E. Warner  
Assistant Transportation Researcher  
Texas Transportation Institute

Craig E. Roco  
Associate Transportation Researcher  
Texas Transportation Institute

Curtis A. Morgan  
Associate Transportation Researcher  
Texas Transportation Institute

David H. Bierling  
Associate Transportation Researcher  
Texas Transportation Institute

Juan Carlos Villa  
Associate Research Scientist  
Texas Transportation Institute

Sarod P. Dhuru  
Graduate Research Assistant  
Texas Transportation Institute

Chad J. Zorn  
Graduate Research Assistant  
Texas Transportation Institute

Report 0-4565-1  
Project Number 0-4565  
Research Project Title: Public-Private Partnerships for Enhanced Intermodal Rail Service in  
Texas

Sponsored by the  
Texas Department of Transportation  
In Cooperation with the  
U.S. Department of Transportation  
Federal Highway Administration

October 2003

TEXAS TRANSPORTATION INSTITUTE  
The Texas A&M University System  
College Station, Texas 77843-3135



## **DISCLAIMER**

The contents of this report reflect the views of the authors, who are responsible for the facts and the accuracy of the data presented herein. The contents do not necessarily reflect the official view or policies of the Federal Highway Administration (FHWA) or the Texas Department of Transportation (TxDOT). This report does not constitute a standard, specification, or regulation. The researcher in charge of this project was Stephen S. Roop.

## ACKNOWLEDGMENTS

The authors would like to thank Wilda Won, the project director, and Wayne Dennis, the project coordinator, for their support and direction with the project. The authors are also grateful for the participation of TxDOT Research and Technology Implementation Office members Andrew Griffith and Martha Norwood and the Project Monitoring Committee members Gilbert Wilson (TxDOT), Danny Magee (TxDOT), Raymond Sanchez (TxDOT), John La Rue (Port of Corpus Christi), Jay Chapa (Burlington Northern Santa Fe Railway), and Joe Adams (Union Pacific Railroad).

The research team on several occasions met with members of both Union Pacific Railroad (UP) and Burlington Northern Santa Fe Railway (BNSF). The authors would like to thank the railroads for their participation. Members involved in meetings or phone conversations from the railroads include:

- BNSF – Randy Bass, Steve Branscum, Jay Chapa, Matt Igoe, Dennis Kearns, Sam Kyei, John Lystic, Martin Manasco, Ed McNack, David Mehl, Denise Rinehart, Steve Salzman, Gail Seaman, John Tinker, and Sherry Williams; and
- UP – Joe Adams, John Hovanec, Wint Marler, Ron Olson, and Ben Shelton.

Special thanks go to Sarod Dhuru, with BNSF. Prior to joining BNSF, Sarod worked diligently as a graduate student at Texas Transportation Institute on this project.

This project was conducted in cooperation with TxDOT and FHWA.

# TABLE OF CONTENTS

	<b>Page</b>
List of Figures .....	x
List of Tables .....	xi
Chapter 1: Introduction .....	1
Why Intermodal? .....	1
Chapter 2: Freight Shippers Needs and Modal Operations .....	3
Shippers.....	3
Product Attributes .....	4
Reliability.....	4
Shipping Costs .....	4
Carriers.....	6
Trucking Industry.....	6
Railroad Industry .....	8
Intermodal Shipping.....	12
Attributes of Intermodal.....	12
Benefits of Intermodal Shipping by Rail .....	13
Deficiencies of Intermodal Shipping by Rail.....	15
Chapter 3: Intermodal Equipment and Services .....	19
Railroad Intermodal Technologies.....	19
Container on Flatcar.....	19
Trailer on Flatcar.....	21
RoadRailer and RailRunner .....	22
Circus Loading.....	23
Land Ferry.....	23
Modalohr.....	24
Current Intermodal Services in Texas.....	25
Union Pacific Railroad.....	25
Burlington Northern Santa Fe.....	29
Kansas City Southern.....	33
Short-Haul Intermodal .....	33
Florida East Coast Railroad .....	34
Norfolk Southern .....	34
Canadian Pacific .....	35
Chapter 4: Key Texas Transportation Corridors.....	37
Federally Designated Corridors .....	37
National Highway System High-Priority Corridors .....	37
High-Speed Rail Corridors .....	38
Freight Analysis Framework .....	40
Future Corridor Development in Texas .....	43
Trans Texas Corridor .....	43

Interstate 69.....	45
Ports-to-Plains Trade Corridor.....	45
Chapter 5: Project Selected Corridors.....	47
Selection Considerations.....	47
Multimodal Corridors.....	47
Truck and Traffic Volumes.....	48
Intermodal Facilities and Services.....	48
Railroad Interest.....	48
Laredo to Dallas Corridor: Interstate 35 – Union Pacific Railroad.....	49
Corridor Overview.....	49
Highway Characteristics.....	50
Rail Route Characteristics.....	52
Laredo to Dallas Enhanced Intermodal Option.....	54
Houston to Dallas Corridor: Interstate 45 – Burlington Northern Santa Fe Railway.....	55
Corridor Overview.....	55
Highway Characteristics.....	56
Rail Route Characteristics.....	57
Houston to Dallas Enhanced Intermodal Option.....	59
El Paso to Dallas Corridor: Interstate 10-Interstate 20 – Union Pacific Railroad.....	60
Corridor Overview.....	60
Highway Characteristics.....	61
Rail Route Characteristics.....	62
El Paso to Dallas Enhanced Intermodal Option.....	65
Chapter 6: Economic Analysis of Intermodal Rail.....	69
Economic Analysis Fundamentals.....	69
Need for an Economic Model.....	70
Results for Selected Intermodal Corridors.....	78
Chapter 7: Forms of PUBLIC-Private Partnerships and Potential Applications in Texas for Enhanced Intermodal Service.....	85
History of State-Rail Company Partnerships in Texas.....	85
Defining Partnerships and PPPs.....	87
Various Forms of PPPs.....	89
Comprehensive Rail Policy Considerations.....	91
Possible State-Rail Public-Private Partnership Strategies.....	93
Legal and Political Obstacles to the formation of PPPs.....	97
Application of PPPs in Texas.....	99
HB 3588 Provisions.....	99
PPP Participants and Likely Scenarios.....	100
Examples of Potential Public Participants in Rail-Related PPPs.....	100
Examples of Potential Private Participants in Rail-Related PPPs.....	102
Possible Scenarios for Enhanced Intermodal Services.....	103
Guidelines for setting up Enhanced Intermodal PPPs in Texas.....	106
Additional Sources for Information on PPPs.....	110



Chapter 8: Conclusions and Recommendations .....	111
Overview.....	111
Project Implementation.....	112
Economic Assessment .....	113
Appendix A: Annotated Bibliography .....	115
Appendix B: Glossary of Selected Report Terms.....	121
References.....	125

## LIST OF FIGURES

	<b>Page</b>
Figure 1. Freight Transportation Service Spectrum.....	15
Figure 2. Rail Intermodal Equipment.....	22
Figure 3. Hupac’s Rolling Highway Service.....	24
Figure 4. Modalohr Concept Schematics.....	25
Figure 5. Union Pacific Intermodal Ramp Locations Map.....	26
Figure 6. Union Pacific Blue Streak Network.....	27
Figure 7. Union Pacific International Intermodal Service.....	29
Figure 8. BNSF’s Intermodal Network.....	30
Figure 9. Mexi Modal Network.....	32
Figure 10. Federally Designated High-Priority Corridors.....	38
Figure 11. Designated High-Speed Rail Corridors Located in Texas.....	39
Figure 12. 1998 Daily Truck Volume from the Freight Analysis Framework.....	41
Figure 13. 2020 Daily Truck Volume from the Freight Analysis Framework.....	41
Figure 14. Total U.S. Rail Flows, 1999.....	42
Figure 15. Freight Flows to, from, and within Texas by Rail, 1999.....	43
Figure 16. Proposed Trans Texas Corridor.....	44
Figure 17. Proposed Interstate 69 Corridor.....	45
Figure 18. Ports-to-Plains Trade Corridor.....	46
Figure 19. Laredo to Dallas Corridor.....	50
Figure 20. Houston to Dallas Corridor.....	56
Figure 21. El Paso to Dallas Corridor.....	61
Figure 22. West Coast – South Central-Southeast Route Efficiencies Gained from Union Pacific Merger with Southern Pacific.....	63
Figure 23. Union Pacific’s High-Priority Transcontinental Train Including Business and Sleeper Cars.....	66
Figure 24. Spreadsheet Model for the Economic Analysis of Intermodal Rail.....	71
Figure 25. Example of Intermodal Rail Project Success with Regard to Planning for the Trans Texas Corridor.....	75
Figure 26. Sample Input and Output Data for the Laredo to Dallas Rail Corridor.....	79
Figure 27. Public and Private Economic Benefits for the Laredo to Dallas Corridor.....	80
Figure 28. Sample Input and Output Data for the Houston to Dallas Rail Corridor.....	82
Figure 29. Public and Private Economic Benefits for the Houston to Dallas Corridor.....	83
Figure 30. Spectrum of Infrastructure Public-Private Partnerships.....	89
Figure 31. Balancing the Value of Public-Private Partnerships.....	113

## LIST OF TABLES

	<b>Page</b>
Table 1. Impact of Transportation Modes on Supply Chain Performance. ....	4
Table 2. Trucking Costs per Mile. ....	7
Table 3. FRA Track Classification. ....	10
Table 4. Maximum Allowable Speeds for Curved Track. ....	10
Table 5. Marginal Costs of 80 kip 5-Axle Truck Traffic on Highways. ....	14
Table 6. U.S. NACS Intermodal Ramps. ....	31
Table 7. Laredo to Dallas Corridor Mileage Analysis. ....	51
Table 8. Laredo to Dallas Corridor Traffic Volumes and Capacity Levels. ....	51
Table 9. Laredo to Dallas Corridor Truck Volumes. ....	52
Table 10. Laredo to Dallas Corridor Intermodal Service. ....	55
Table 11. Houston to Dallas Corridor Mileage Analysis. ....	56
Table 12. Houston to Dallas Corridor Traffic Volumes and Capacity Levels. ....	57
Table 13. Houston to Dallas Corridor Truck Volumes. ....	57
Table 14. Houston to Dallas Corridor Intermodal Service. ....	60
Table 15. El Paso to Dallas Corridor Mileage Analysis. ....	61
Table 16. El Paso to Dallas Corridor Traffic Volumes and Capacity Levels. ....	62
Table 17. El Paso to Dallas Corridor Truck Volumes. ....	62
Table 18. El Paso to Dallas Corridor Intermodal Service. ....	68
Table 19. OMB Real Discount Rates for 2003. ....	76
Table 20. Changes in OMB Real Discount Rates between 2002 and 2003. ....	77
Table 21. 1975 NCSL Recommendations to State Governments to Preserve Rural Rail. ....	92
Table 22. AASHTO SCORT Freight Rail PPP Funding Strategies. ....	94
Table 23: Stages of Partnership Development. ....	107



# CHAPTER 1: INTRODUCTION

## WHY INTERMODAL?

The recognition by transportation professionals that there is a need for a balanced and better integrated transportation system has given rise to greater interest in using the capabilities of multiple transport modes to move intercity freight, rather than the continued use of one primary transport mode (trucks) for intercity freight transport. The failure to formulate a productive and mutually beneficial alliance between public and private transportation providers may result in a highway system that is overwhelmed with traffic levels that degrade infrastructure and service levels to a point where overall economic vitality is reduced.

*Intermodal* freight transport is a concept that has been around for decades, and whose use continues to grow. It is not as simple as it looks or seems. At first glance, it is as straightforward as just putting a trailer or container on a flatcar and sending it off. In fact, there is a plethora of methods and equipment on the market, which makes providing intermodal service somewhat complex. However, the basic concept of intermodal is simple: the idea of *unitized freight*. This means that products are loaded into a container or trailer and not unloaded until they have reached their final destination. While in transit, the trailer or container can be delivered by any combination of truck, rail, or ship to its final destination.

Research shows that public-private partnerships and joint developments are both implementable and successful in realizing solutions to transportation problems. Ultimately, these partnerships revolve around financing mechanisms, which vary at local, state, and federal levels and from city to city or state to state. The future of solutions to transportation problems lies, at least in part, in continued application of public-private partnerships in both infrastructure development (capital costs) and operation and maintenance (marginal costs). These partnerships need to be considered and evaluated in light of the infrastructures needed for anticipated developments in transportation technologies and the corresponding impacts to Texas Department of Transportation's (TxDOT's) planning and financing options.

The results of this project have the potential to help fundamentally alter the manner in which freight transportation is approached in Texas – both from the public and the private perspective. From the public sector's point of view, investment in intermodal infrastructures as an alternative to adding highway capacity, for instance, should be evaluated in terms of the

economic and practical “value” of that investment relative to the alternatives. The project provides the public sector with an understanding of needs and the constraints under which intermodal carriers operate. This work also provides important guidance on structuring public-private partnerships and strategies for overcoming legal, institutional, and policy barriers to collaboration and references decision-support tools that may assist in quantifying the benefits and costs of selected projects. The organization of this report follows these focus areas:

- compilation of an annotated bibliography on previous work and studies in freight transport and public-private partnerships ([Appendix A](#));
- discussion of factors influencing shippers’ mode choice decisions, and economic and operating variables encountered by truck and rail freight carriers ([Chapter 2](#));
- description of intermodal service offerings or products currently provided by the railroads and that have potential to capture freight market share and induce use by trucking interests or shippers ([Chapter 3](#));
- identification of key trade corridors in Texas, and analysis of three specific corridors (case studies) in the state as candidates for increased intermodal services ([Chapters 4 and 5](#));
- discussion of potential economic benefits achieved by intermodal freight transport in general and over the identified case studies ([Chapter 6](#)); and
- definition of the parameters and mechanisms required for effective public-public and public-private initiatives to facilitate movement of intermodal freight ([Chapter 7](#)).

## CHAPTER 2: FREIGHT SHIPPERS NEEDS AND MODAL OPERATIONS

In order to better understand the advantages that intermodal technologies and methodologies bring to freight movement, it is necessary to understand the competitive landscape and operations of trucking and rail-hauled freight. The dominance enjoyed by the U.S. railroads in freight movement in the 1800s and early 1900s was gradually supplanted by the trucking industry, which today captures approximately 86 percent of the freight revenue in the U.S. (1). Automobiles and the airlines have also replaced the rails dominance in passenger transportation. Like all modes, railroads today are transportation specialists that focus on those commodities and services that return the maximum profit to their shareholders given the constraints of their operating environment. Economics have pushed railroads toward long-haul operations and bulk commodities. They are the principal carriers of bulk chemicals and retain a vital role in the transport of coal. While railroads move 40 percent of the freight ton-miles in this country, they capture only 10 percent of the revenue (2).

At the heart of this shift are the shipping needs of customers, and capital and operating costs and factors affecting overland carriers. The following [section](#) discusses shipper concerns as they impact freight transportation decision-making.

### SHIPPERS

The “shipper” is located either at the origin or destination, although the destination’s requirements can play a more significant role in selection of a freight method. While shippers may have several alternatives for selecting a mode of transportation, their core interest is the movement of their products from one location to another at the lowest price possible with highly predictable delivery. Generally shippers are not concerned with exactly how (meaning the mode of transportation) the freight is shipped. Shippers select a suitable carrier based on several factors, including cost, service availability, delivery requirements, volume, and the shipped product attributes.

[Table 1](#) compares the various transportation modes from a shipper’s point of view. Each aspect of inventory management is rated on a scale of “1” to “6” for each transportation mode, where “1” represents low costs or requirements and “6” represents high costs or requirements. Comparing truck load (TL) shipping to rail shipping, we can see the benefits and drawbacks of

choosing one form of transportation over another. An intermodal solution would effectively “split the difference” between the two, offering smaller lots and slightly slower service and a better price when compared to trucks.

**Table 1. Impact of Transportation Modes on Supply Chain Performance (3).**

	<b>Rail</b>	<b>TL</b>	<b>LTL</b>	<b>Package</b>	<b>Air</b>	<b>Water</b>
Lot Size	5	4	3	1	2	6
Safety Inventory	5	4	3	1	2	6
In-transit Inventory	5	4	3	1	2	6
Transportation Cost	2	3	4	6	5	1
Transportation Time	5	3	4	1	2	6
TL – Truck Load; LTL – Less Than Truckload						

### **Product Attributes**

Product attributes have a strong influence on the selection of shipment method. Some of these attributes include volume of product that needs to be shipped, the cost of carrying inventory or safety-stock, product density, and distance to be shipped. For example, rail is the preferred method of shipping bulky commodity products such as coal or gravel because of the low cost of transportation relative to the cost of the product, high volume being moved over long distances, and a low cost of storage. While it is possible to move this material by truck, the higher cost of this shipping method does not provide any benefit. In general, as the product density decreases, storage cost increases, shipping distance decreases, or shipment volume decreases, the preferred mode of travel shifts to intermodal, then truck.

### **Reliability**

In market surveys, shipping companies cite reliability as the most important factor, as this reduces variability in their forecasting. If products are delivered with high predictability, the need for safety-stock and emergency orders goes down. If predictability declines, the difficulty and cost of forecasting and planning increases, ultimately reaching a point where it is less expensive overall to spend more money on a more reliable method of transportation.

### **Shipping Costs**

The Federal Highway Administration (FHWA) Office of Freight Management reports that the expense to ship products by truck has remained virtually unchanged over the last decade.



The average shipping costs per mile for all types of for-hire truck transportation were \$1.78 in 2000 (4). Comparing constant dollars from 1990 to 2000 shows the constant dollar expenses per mile reduced from \$1.51 to \$1.34 (4). Several variables affect truck expenses and shipping rates:

- **Type of Product:** This influences the price based on the density of the product being shipped, the related special equipment that is required, the risk of carrying the product, and additional insurance or training required to be able to carry that product.
- **Origin and Destination:** Because trucking market rates are unregulated, the prices are based on the demand and supply of trucking at both the origin and destination. Areas where trucking is not readily available due to a limited number of loads either arriving or departing from a location will push the price up, as it costs more time and money to find a new load and avoid phantom freight.
- **Urgency of the Shipment:** Shipments higher in urgency rely on premium services with greater shipping rates.

Railroad shipping rates vary by origin, destination, distance, and commodity and have been greatly affected by the passage of the Staggers Rail Act of 1980. Prior to the Staggers Act, the Interstate Commerce Commission regulated rail rates, which forced railroads to develop rates according to regulation instead of the open marketplace. Since the passage of the Staggers Act, railroads have greatly improved productivity, resulting in significant rail rate reductions. The Surface Transportation Board reported in December 2000 that from 1984 to 1999, inflation-adjusted rail rates declined 45.3 percent (5). The following is a list of commodity-specific rail rate reductions from 1981 to 2001, each adjusted for inflation:

- coal – 62 percent reduction,
- motor vehicle traffic – 35 percent reduction,
- wheat – 54 percent,
- corn – 41 percent, and
- soybeans – 53 percent (5).

## **CARRIERS**

The following sections discuss cost and operating factors that affect truck and rail carriers.

### **Trucking Industry**

The unparalleled highway transportation system in the U.S., typified by Texas with more than 77,000 miles of publicly financed and maintained roadways, has given rise to a highly efficient and capable trucking industry that has in turn encouraged innovations in business practices such as just-in-time manufacturing (which moves the storage location of industrial inventories from warehouses to the transportation system). The adoption of advanced logistics in the manufacturing sector has proven to be closely related to the efficiency of the freight transportation sector and a major driver of highway use by trucks.

The primary advantage of using a truck versus other types of transportation modes is the low cost combined with the ease of doing business. As trucks use the public highway system, they are able to pick up and drop off shipments at almost any location. In addition, there are generally no special requirements for the pick up or delivery locations. For example, construction materials can be delivered to any location where there is a forklift and enough room for truck loading/unloading. Trucks are the only practical choice for moving freight to and from locations that are not serviced by other modes of transportation, although the vast majority of shipments do occur between metropolitan areas despite access to intermodal facilities.

Compared with other forms of transportation, highway trucks require the lowest amount of private capital investment because they consist of only a tractor and a trailer. The infrastructures are partially paid for through fuel taxes, with the trucking industry not covering an adequate share of the cost of damages. According to the American Association of Railroads (AAR), a \$0.50 investment in the trucking industry will return \$1.00 in revenue (6). [Table 2](#) breaks down the cost of operating a truck on a per-mile basis (7). The top four costs are labor (driver), fuel, overhead, and maintenance.

**Table 2. Trucking Costs per Mile.**

<b>Item</b>	<b>\$/mi</b>	<b>%</b>	<b>Type</b>
Interest on tractor and trailer	0.029	2.23	Fixed
Vehicle depreciation	0.087	6.68	Fixed
Insurance	0.100	7.68	Fixed
Management & Overhead	0.160	12.29	Fixed
Depreciation & Other interest	0.016	1.23	Fixed
Fuel	0.192	14.27	Variable
Tires	0.027	2.07	Variable
Maintenance	0.154	11.83	Variable
License	0.095	7.30	Fixed
Driver	0.375	28.80	Variable
Miscellaneous	0.067	5.15	Variable
<b>Total</b>	<b>1.302</b>		

### ***Cycle Time***

Truck drivers that work for a trucking company are paid on a ‘dollars per mile traveled’ basis, which rewards them for traveling from origin to destination in the shortest time possible in order to accumulate the most miles and make the most money. Because of this basic philosophy, in order for truck drivers to support an intermodal solution they must see an ability to earn equal or greater revenues than they would by driving. An intermodal solution could benefit truck drivers by reducing their cycle time, thereby permitting them to get to a destination faster and allowing drivers to use their equipment in a more efficient manner or lower their operating costs substantially. Independent truck drivers generally get paid a flat rate based on the origin and destination of the load being shipped but still have the same incentives as those truck drivers working for trucking companies: an intermodal solution that reduces cycle time or lowers costs.

### ***Potential Solutions***

One method to lower the truck driver’s cycle time is to travel during the driver’s rest period. Some truck drivers work as a team, where one driver drives the truck while the other sleeps. When the sleeping driver’s rest period is over, they trade. This allows the truck to cover more miles and results in better asset utilization and lower cycle time. While this expedited service does carry a premium and pays the drivers a premium, the profits resulting from the freight movement now must be split. If an intermodal service could be designed where the entire truck with driver can be moved during the driver’s resting period and charge less than what a

'team-member' would be paid, then one driver could make the same trip in the same time and keep the additional profit.

A problem that affects the trucking industry is a high turnover in truck drivers due to the nomadic lifestyle of traveling for days at a time. A potential intermodal solution would reduce the need for long-haul drivers, as a driver could travel part of the full dray distance and load the trailer onto an intermodal freight train for delivery to the destination terminal. The truck driver can then pick up a trailer from the terminal and return with it to his city of origin, allowing a driver to spend more time at home.

## **Railroad Industry**

Modern railroads are transportation specialists that focus on long-haul or intercity movements, usually of bulk commodities. The most significant difference between railroads and trucking companies is that railroads own and maintain their own infrastructure, adding significant expense to the internal cost of shipping by rail. As a capital- and labor-intensive industry, railroads must invest approximately \$2.50 in their operations and infrastructure to return \$1.00 in revenue, compared with the \$0.50 investment on the part of the trucking industry, as identified previously. Further, the fixed route structure of the railroads limits the railroad's ability to compete with a trucking industry that has far more inherent flexibility in point-to-point transportation and just-in-time delivery.

Despite the cost handicap, railroads are able to capture a significant amount of freight traffic in the long-haul market for products that are not critical in nature. It is in the short-haul market where rail has a difficult time competing against trucks. This is due to several reasons, such as fixed routes prohibiting door-to-door service and lead times substantially longer than truck service. In 2001, rail traffic declined by 2.9 percent and was down by 3.0 percent as of July 2002 (8).

Individual railroads have advantages in service areas where they own the rail and have exclusive operating rights, thus limiting the competition to trucking companies. Shippers in these areas are typically charged higher rates than if there was more than one railroad present but less than the cost to ship by truck. The railroads use the additional profits earned in these scenarios to invest in operations in areas where there is competition and margins are thin (9). It

should also be noted that despite the higher rates in certain areas, overall freight rates have gone down because of competition with trucks (9).

### ***Factors Affecting Rail Capacity***

Capacity on any rail network is affected by a combination of factors, which the railroads are attempting to address. These factors include the following.

**Track Availability.** Track availability refers to having the physical space to accommodate trains and cargo on the railroad system. Several factors can impact the availability of track infrastructure, including:

- Double tracking of mainline segments of the railroad increases capacity by allowing trains to operate without using sidings to pass or to allow other trains to pass. Often there is a significant delay involved as one train waits for the other. In addition, as has been the case with Union Pacific's (UP's) acquisition of Southern Pacific (SP), double-track operations can set the stage for "directional operations," where one line is designated for traffic moving in a particular direction and the other line is designated for traffic moving in the opposite direction. This strategy greatly increases not only capacity, but safety as well. Train speeds can be increased and the need for passing sidings reduced.
- Added passing siding has an impact similar to that of double tracking, increasing the number and frequency of trains that can be moved through a segment of track. As the distance between sidings is decreased, track sections begin to have capacity characteristics approaching a double-tracked segment of line. Siding length also contributes to capacity. Longer passing sidings allow the railroad to build longer trains, thus reducing the total number of trains necessary to move the same amount of goods. The industry is currently running trains up to 7000 feet in length.
- Train control systems such as centralized traffic control (CTC) add to the capacity of a track segment by allowing centralized dispatchers to monitor train movements from a control center. This centralized control improves both capacity and safety.
- Track speed, according to the Federal Railroad Administration (FRA) track class standards, refers to the quality of the track and, hence, the operating speeds at which the railroads may run trains. Higher speeds mean greater train throughput

and greater capacity. The class of a track is achieved by constructing the track to a certain standard and maintaining it at a certain level of repair. This level pertains to the engineering and maintenance of both track geometry, for track gage, alignment, and curvature, and track structure, for ballast, ties, rail, and switches. The FRA track classes and related maximum allowable speeds are presented below in [Table 3](#).

**Table 3. FRA Track Classification (10).**

Track Classification	Maximum Allowable Speed (mph)	
	Freight	Passenger
Class 1	10	15
Class 2	25	30
Class 3	40	60
Class 4	60	80
Class 5	80	90
Class 6	110*	110
*Special conditions apply		

The previous [table](#) reflects the maximum allowable speeds given ideal, straight track geometry conditions. Circumstances where the geometry includes curved track reduce the maximum allowable operating speeds, significantly in situations where the outside track is not elevated. [Table 4](#) contains a listing of the maximum allowable speeds for curved track for a series of degree of curvature-elevation of the outside rail scenarios. In the scenario with one inch of outside rail elevation, the maximum allowable speed reduces by one-half from a slight curve to one with two degrees of curvature. For all elevation options, maximum train speeds reduce drastically for severe curves.

**Table 4. Maximum Allowable Speeds for Curved Track (10).**

Degree of Curvature	Elevation (inches)						
	0	1	2	3	4	5	6
	Maximum Allowable Operating Speed (mph)						
0°30'	93	107	-	-	-	-	-
1°00'	66	76	85	93	100	107	-
2°00'	46	54	60	66	71	76	80
3°00'	38	44	49	54	58	62	66
4°00'	33	38	42	46	50	54	57
5°00'	29	34	38	41	45	48	51
10°00'	21	24	27	29	32	34	36

**Classification and Intermodal Yards.** Railroad capacity and throughput is determined in large measure by the ability of terminals – classification and intermodal yards – to organize and move freight in and out. The point on a railroad where congestion nearly always begins can usually be traced to yard facilities and the inability to move out as much freight as is brought in. The role of a classification yard is to take apart trains that have material being shipped to multiple destinations and reconstruct trains for which most of the cars in each train are destined to the same region.

Intermodal yards are slightly different in that they focus on the handling of trailer on flatcar (TOFC) and container on flatcar (COFC) shipments and must have the infrastructure available to position and remove trailers and containers, moving shipments from trucks to railcars or vice versa. The railroads can improve intermodal yard performance by increasing the size of the yard and improving the ramps used to load trailers and by upgrading the equipment that lifts containers and places them on trains and trucks.

**Improved Equipment.** Capacity can be increased by employing improved equipment, such as double-stack cars for carrying two stacked containers or the use of lightweight grain cars that allow the railroads to increase the commodity carried by each car. Maintaining a sufficient locomotive fleet is also critical to capacity on the railroad, and balancing “power” (i.e., locomotive horsepower) required for varying locations is a difficult and continually managed process. New, higher-horsepower locomotives, which are a very significant investment for the railroads, may ease the challenge in balancing power due to the fact that two new locomotives may replace three older, lower-power models.

**Crew Availability.** In terms of its impact on capacity, crew availability is similar to the availability of locomotives. A shortage of ready, trained, and usable crews is as damaging to railroad operations as a shortage of power. There are other similarities in the logistical challenges associated with having the right crews in the proper place when they are needed to operate a train. FRA work rules limit the number of hours a crew can be on the job to 12 consecutive hours. This period must be followed by 10 consecutive hours of rest. If a crew is only halfway to its destination when their 12-hour shift lapses, they must cease operations immediately. This requirement can mean that they are forced to stop a train in the middle of a single-track line and block traffic until another crew can be brought in to relieve them. It is readily apparent that, under conditions of substantial business growth, a railroad could become

service constrained by a lack of rested or properly dispersed crews. It is, therefore, important for the railroad to carefully plan how many crews are hired and trained and where they are stationed.

## **INTERMODAL SHIPPING**

Intermodal transportation is an ideal method of transportation that takes advantage of the strengths of several forms of transportation. Trucks, for example, are ideally suited to local delivery of goods, as they are able to travel almost anywhere, quickly. Long-distance trucking is expensive, however, with the bulk of the cost going to fuel and driver salary. Rail, on the other hand, is ideal for delivering large quantities of product over longer distances. It is limited, however, as it can only travel where there is rail infrastructure. The combination of truck and rail services creates an intermodal method of transportation that is efficient, environmentally friendly, safe, and low in cost. However, it is difficult to create a plausible business plan for an intermodal solution where the corridor is less than 500 miles long. One reason is that the cost of short runs is very high, thus making the retail price too high, especially when compared to truck rates alone. Not only is the cost to the shipper higher, but the transit time from origin to destination is considerably longer than the time it takes to ship by truck alone at this distance.

Loading and unloading is composed of the time it takes for the container or trailer to be removed from the delivering truck and placed on the flat railcar. While it only takes approximately one minute to load each trailer, with only one crane loading a train that will carry 100 trailers, intermodal adds 200 minutes (loading and unloading) to the transit time (11).

### **Attributes of Intermodal**

Intermodal shipments are an important method of providing for long-distance freight transportation in and through the state of Texas. Due to Texas' key geographic location on both international and transcontinental trade routes, a large portion of the nation's freight traffic, moving by either rail or truck, passes through or terminates within the state's borders. For example, in the year 2000, intermodal trains were responsible for transporting 199 million tons and 421 billion ton-miles at the national level—the equivalent of 16.2 billion miles of truck traffic alone (12).

Intermodal business has been one of the fastest growing sectors within the railroad industry over the past several years. In fact, a recent study conducted for the Association of



American Railroads projected that rail intermodal movement, which includes TOFC, COFC, and double-stack COFC train types will likely overtake coal transport as the largest revenue source for any single type of rail movement at some point during the 2003 calendar year (13).

### **Benefits of Intermodal Shipping by Rail**

#### ***Highway User Benefits: Reduced Congestion and Maintenance Cost Reduction***

Intermodal freight shipping, combining truck and rail, has many potential public benefits over truck-only movements. One of the most often cited benefits is the role that intermodal can play in taking large numbers of trucks off the highway, thereby reducing highway congestion in urban areas and along high traffic-density trade corridors. By moving long-distance freight from the highway to rail rights-of-way, more existing highway capacity is left for use for personal travel in automobiles and light trucks and for local delivery of goods. While not every freight commodity is conducive to being shipped by container, those that are can often be transported for most of their total movement by rail just as efficiently as by truck. This can have enormous financial, traffic safety, social, and environmental benefits. On average, one double-stack container train can move the equivalent of 280 trucks, thereby increasing highway capacity by approximately 1100 automobiles (14). In fact, other train types carrying non-intermodal cargo are capable of removing as many as 500 trucks per train (14).

While relieving congestion, such a reduction in the numbers of trucks using the highway system could also greatly reduce the costs of long-term highway maintenance. The expenses associated with truck damage to highway infrastructure are staggering. The current maximum weight allowed for trucks on Texas highways, without a special permit, is 80,000 pounds. Previous studies in this area have shown that the impact of one truck loaded to this weight does the same amount of damage to the underlying roadway structure as approximately 9600 automobiles (15). As shown in Table 5, the marginal costs associated with each mile of truck travel at this weight, when all costs are accounted for, are approximately \$0.199 cents per mile per truck in rural areas and approximately \$0.696 cents per mile per truck in urban areas.

**Table 5. Marginal Costs of 80 kip 5-Axle Truck Traffic on Highways (16).**

Cost Category	Marginal Costs (2000 \$)	
	Rural Trucking (\$/mile)	Urban Trucking (\$/mile)
Congestion	0.0223	0.2006
Collision	0.0088	0.0115
Pollution	0.0385	0.0449
Noise	0.0019	0.0304
Pavement	0.1270	0.4090

Although few individual container trucks approach this 80,000-pound weight limit, the damage inflicted by repetitive truck loadings at lower weights can rapidly accumulate—continuously generating pavement, environmental, and social costs.

Costs to the public sector in the road maintenance, congestion, and collision categories can be reduced or avoided by using rail to transport containerized freight. The ability to handle multiple containers on each railcar and to move many such railcars using the locomotive power of one train magnifies this rail benefit. By developing policies that encourage rail transport, the public sector is also implicitly fostering needed reinvestment by the railroad companies into improving the performance and capabilities of the rail system. The cost of track maintenance and rehabilitation is transferred to the private sector railroad companies and its users. Public dollars that would have been spent on roadway reconstruction and rehabilitation may be put to work elsewhere.

### ***Energy and Environmental***

In addition to its highway preservation benefits, rail transportation has several energy use and environmental advantages over highway transportation. According to the AAR, in 2001 the average locomotive moved a ton of freight approximately 403 miles for every gallon of diesel fuel used. The AAR also states that railroads are three or more times more fuel efficient than trucks (17). As a result of such fuel efficiency, shifting even a small percentage of highway freight to rail could potentially result in the conservation of millions of gallons of fuel each year (17).

As a result of better fuel economies per ton transported, rail transportation is also more environmentally friendly than movement by truck on a ton-mile basis. Environmental Protection Agency (EPA) reports on transportation-related pollution state that only nine percent of nitrogen

oxide (NOx) emissions and four percent of particulate emissions are attributed to rail transportation, even though rail moves over 40 percent of the intercity freight on a ton-mile basis (17). The intermodal percentage of this freight reduces emissions by consolidating large numbers of trucks into single train movements with a net reduction in overall emissions.

**Reduced Shipper Cost**

Intermodal rail movement fills an important niche in the freight transportation industry by providing a cost-effective alternative to long-distance trucking while providing many of the same benefits since trucks often are responsible for delivery at each end. Intermodal rail also tends to carry the more valuable commodities within the rail transport segment as shown in Figure 1 below.

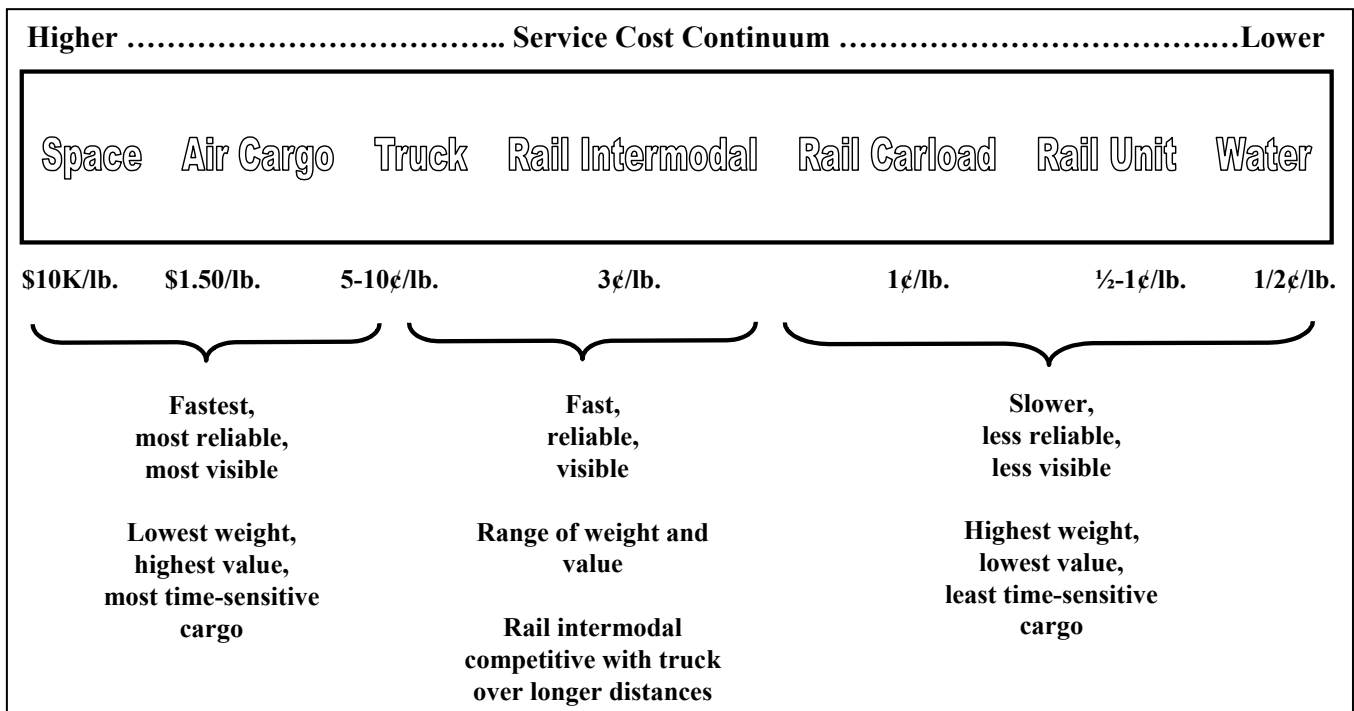

**Figure 1. Freight Transportation Service Spectrum (12).**

**Deficiencies of Intermodal Shipping by Rail**

**Lack of Door-to-Door Delivery**

The intermodal rail system represents a fixed network of rail lines traveling between major intermodal facilities, thus providing a service that rarely connects the origin or destination locations. Direct connections to port terminals are an exception, but the vast majority of

intermodal movements by rail require a truck to handle the movement from the origin and to the destination with rail handling the middle, long-haul component. This need for truck involvement at the trip beginning and end may reduce the benefit of removing trucks from the highway in urban areas.

Several factors contribute to the current situation, including the concentration of intermodal activities at fewer, larger facilities. This allows the railroads to focus their resources and improve efficiency at fewer locations and on fewer connecting lanes. Also contributing is the development of the highway system. Industrial areas have increasingly developed along the highway system, and not necessarily along the rail network, in order to provide better access for truck shipments.

### ***Service Levels***

The two primary concerns for shippers are reliability and transit time. Railroad operations have historically lagged behind trucks in both these categories, including intermodal operations. Today, intermodal represents one of the fastest growing markets for the railroads and has prompted them to find ways of providing truck-competitive intermodal service. Working closely together by providing seamless interchanges, the railroads have begun providing guaranteed “on-time” intermodal services. These money-back guarantees have resulted in higher service levels that have reduced transcontinental transit times by days in some cases. A list of some of these services that include Texas markets appears in [Chapter 3](#).

### ***Capacity and Capital Investment Concerns***

Between 1980 and 1999, rail intermodal ton-miles grew 98 percent, and the industry expects that international container trade will double over the next decade (18). These numbers indicate significant intermodal activity by the railroads but also raise concerns over the rail system’s ability to handle the increased traffic levels. This concern also translates to an already congested highway network.

Concerns over the ability to handle increased intermodal levels exist in both the intermodal facilities and rail network. Many rail terminals reside within the densely developed city centers, where there is little room for expansion. These intermodal facilities, often coexisting with other yard activities, likely have short intermodal tracks that require a train to be broken over several lines and limited space for truck and chassis parking and storage. Newer

intermodal facilities have more room for intermodal activities but may be located outside the urban area, farther from industrial developments. The number and lengths of sidings, level of signaling, and overpass clearance heights regulate the types and size of intermodal trains traveling across the rail network.



## **CHAPTER 3: INTERMODAL EQUIPMENT AND SERVICES**

Intermodal movements by rail take several different forms, from traditional container or trailer moves to new technologies being developed in Europe. This chapter details the different intermodal technologies utilized by railroads in the U.S. and those under development. Also included is a detailed analysis of the current intermodal services provided by the Class I railroads operating in Texas.

### **RAILROAD INTERMODAL TECHNOLOGIES**

The basic premise of intermodal is that goods move in standardized units. However, the reality of today is that intermodal is a highly complex system of different equipment and technologies that must handle multiple sized units. The traditional manner of shipping intermodal goods on the railroads includes the intermodal container and the common trailer. But several newer, specialized equipment technologies are gaining popularity in the U.S. and Europe. The following sections describe several of the intermodal technologies utilized by the U.S. railroads and those in portions of Europe.

#### **Container on Flatcar**

When discussing intermodal solutions, the method that is usually assumed is container on flatcar, or COFC. This is used mostly for international freight that is going to or coming from the ports. COFC usually uses 20 ft or 40 ft containers, common sizes for sea-based shipping. Containers are very efficient for shipping product, especially overseas, because the chassis is separate from the container. For rail service, COFC is more efficient than TOFC because containers can be stacked two high. There are some restrictions in how the containers can be stacked, which creates some planning difficulties, but the more efficient use of flatcars more than makes up for these restrictions. International containers do have some drawbacks, including being smaller than over-the-road trailers (40 ft vs. 53 ft) and also have special reinforcing beams within the containers so that they can be picked up from overhead, which reduces the capacity of the container. Domestic containers used within the U.S. more closely resemble the typical over-the-road trailers in length, adding to the complexity of train planning.

With the continued growth in intermodal traffic, many intermodal facilities in the United States are approaching or exceeding capacity levels. Historically, railroad intermodal terminals

were located within urban areas and, as a result, have no place to expand. Today, railroads are developing new, larger facilities located outside city centers, allowing the railroad companies to consolidate intermodal operations at these new, technologically advanced facilities. The following list provides examples of the size of several existing Texas intermodal facilities and also the size of several new facilities located around the country.

### Existing Texas Facilities

- *UP Englewood Yard (Houston)* – This 100-acre ramp performs approximately 18,000 lifts per month (19).
- *Burlington Northern Santa Fe (BNSF) Pearland Yard (Houston)* – This facility performs approximately 12,000 lifts per month and resides on 83 acres (20).
- *UP Mesquite Yard (Dallas)* – This 130-acre facility performs 16,000 to 17,000 lifts per month (21).
- *UP Miller Yard (Dallas)* – Located on 68 acres, this facility performs approximately 15,000 lifts per month (21).
- *BNSF Alliance Yard (Fort Worth)* – This relatively new, modern facility annually lifts 460,000 trailers and containers and resides on 289 acres. The intermodal facility provides 3420 parking spaces (22).

### Newly Constructed Facilities

- *UP Global III Intermodal Facility (Chicago)* – Costing \$181 million to construct and covering over 800 acres, this facility is designed to handle 720,000 lifts annually. The facility contains four full intermodal train-length tracks and offers 4000 parking places for trailers and containers (23).
- *UP Marion, Arkansas Intermodal Facility* – This \$70 million dollar facility replaces two outdated facilities located in nearby Memphis, Tennessee. Located on 600 acres, these facilities are designed to lift 375,000 trailers and containers annually and offers 2600 parking spaces (24).
- *BNSF Logistics Park (Chicago)* – In addition to intermodal operations, this facility also offers transload services with distribution and warehousing. The entire



Logistics Park resides on 621 acres and expanded BNSF's Chicago area lift capacity from 400,000 to over 3 million annually (25).

### **Trailer on Flatcar**

Most commonly used by less-than-truckload carriers such as United Parcel Service (UPS) and others, TOFC is exactly what it sounds like. The trailer is lifted off the ground using an overhead crane, usually designed to lift both containers and trailers, and placed on top of a rail flatcar. This method is very versatile, as almost any trailer can be used, although it is easier to handle trailers that have been specially reinforced for use in intermodal applications. The drawbacks are that there is a very large variety of trailers of various lengths. Since two trailers are placed on a flatcar, coordination of which trailers can share railcars can be difficult. In addition, trailers cannot be stacked on top of each other as containers can, thus making TOFC less efficient.

Services specifically targeting TOFC movements, such as UPS, are typically high-premium services moving rapidly through the system. Union Pacific, in partnership with CSX Intermodal (CSXI), recently began offering a new expedited cross-country service for UPS from New York to Los Angeles in 63 hours, a service stated to compete with the 60-hour transit times for team-driven trucks (26). With the premium services, TOFC rates are generally higher than for container services, thus generating similar per-train revenues.

Figure 2 shows the typical TOFC and COFC intermodal equipment, including double-stack equipment.

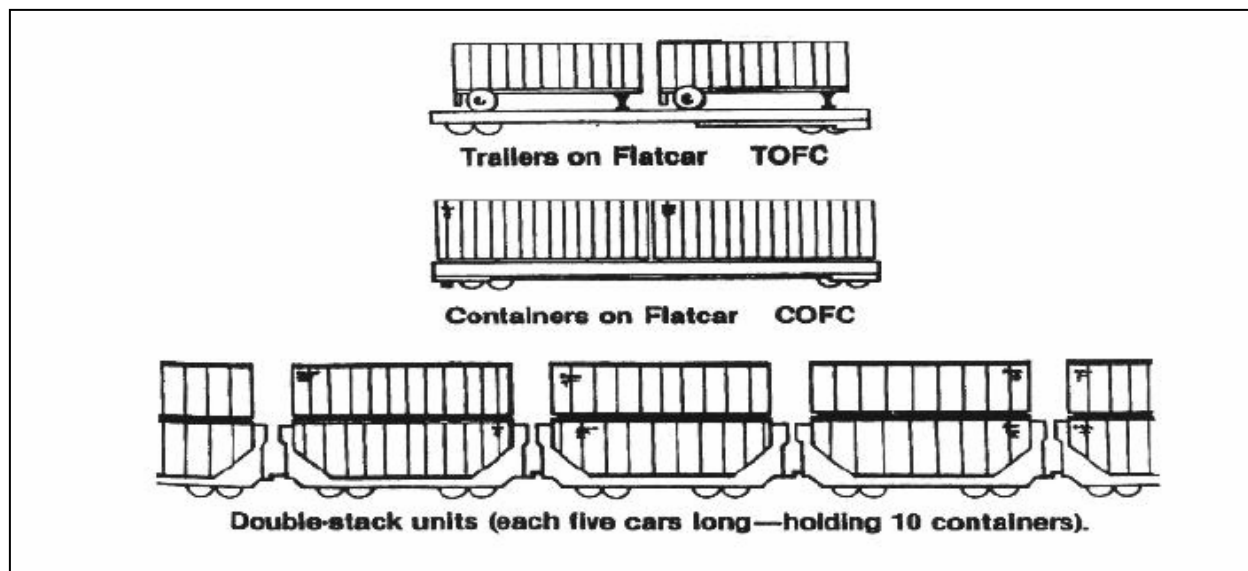

**Figure 2. Rail Intermodal Equipment (27).**

### **RoadRailer and RailRunner**

These two methods use the same basic principle but have some significant differences that may make one better suited than the other in certain situations. The basic principle is similar to TOFC, where the entire trailer is moved by rail between cities; however, there is no flatcar. Instead, these two methods chain trailers and bogies (rail wheel sets) together to make a trailer train. The two methods, RoadRailer and RailRunner, take very different approaches to assembling trains, however.

Both methods use specially designed bogies that run on the rails, but RailRunner's bogies are FRA certified for higher speeds (up to 110 mph) than RoadRailer. In addition, the mechanism to attach equipment together is specific to that system, so equipment is not interchangeable. The principal difference between the two systems is that RoadRailer uses custom-designed trailers. In order to start intermodal service that uses RoadRailer technology, a company must invest in a fleet of trailers. RailRunner, on the other hand, has chosen to use standard intermodal containers. The chassis are still custom designed but can be added to the pool of chassis that an intermodal yard would require anyway.

Both methods provide increased security because when the train is built, the trailers are too close to each other to allow the cargo doors to open. They are both fully articulated as well. This means that the containers do not have any slack between them, so the train operates as one

unit. This reduces the chance of damage in transit. Company representatives also claim that capital costs for these methods are lower because of the minimal requirements for a terminal, which only needs a moderately sized paved lot with rails.

### **Circus Loading**

This method is similar to TOFC, as well, with the difference being how the units are placed on the rail flatcars. The circus loading method is currently being utilized by Canadian Pacific Railway (CP) to service international movements along a route between Montreal and Detroit, with connections at Toronto and Windsor, and soon to extend to Chicago. To circus load a train, the trailer simply backs the trailer onto the flatcar using a ramp at the end. Once it is in position, the trailer is secured and the yard truck pulls away to retrieve another trailer. Circus loading is very versatile, as any type of trailer can be loaded onto the flatcar; however, the flatcars are specially designed to have a continuous platform along their length. This allows trailers to be driven along the entire length into the appropriate position. Again, similar to TOFC, the trailers cannot be double stacked. Operationally, circus loading utilizes smaller, typically dedicated, terminal facilities compared with existing large intermodal facilities.

### **Land Ferry**

This method is identical to the circus loading method, except that the entire truck (tractor and trailer) pulls forward onto the train. There are also passenger cars as part of the train makeup where the drivers of the trucks spend the journey.

This method has been proven successful in Switzerland, where very specific circumstances contribute to the successes in that corridor. The Swiss government was very concerned with both safety when trucks cross the Alps and with highway damage resulting from the trucks passing on their highway system. To help pay for the damage trucks cause to the Swiss highways and to hopefully persuade trucks to drive around their country, the government levied a \$200 (U.S.) tax on every truck that crossed through Switzerland. Despite this, the drive was still cheaper and shorter enough to warrant paying the additional tax, and the Swiss border continued to experience lengthy queues of up to 10 kilometers, or slightly greater than 6 miles (28).

The Hupac Group, a private intermodal provider, opened the land ferry service called the Rolling Highway with the support of a \$300 (U.S.) per truck subsidy from the Swiss government

(28). The railcars, locomotives, and terminals are all owned by Hupac. The service, carrying the tractor, trailer, and driver, operates multiple routes between Italy and Germany, Belgium, and the Netherlands, thus eliminating these trucks from Swiss roadways. [Figure 3](#) shows the land ferry service loading of the trucks and carrying the entire truck.

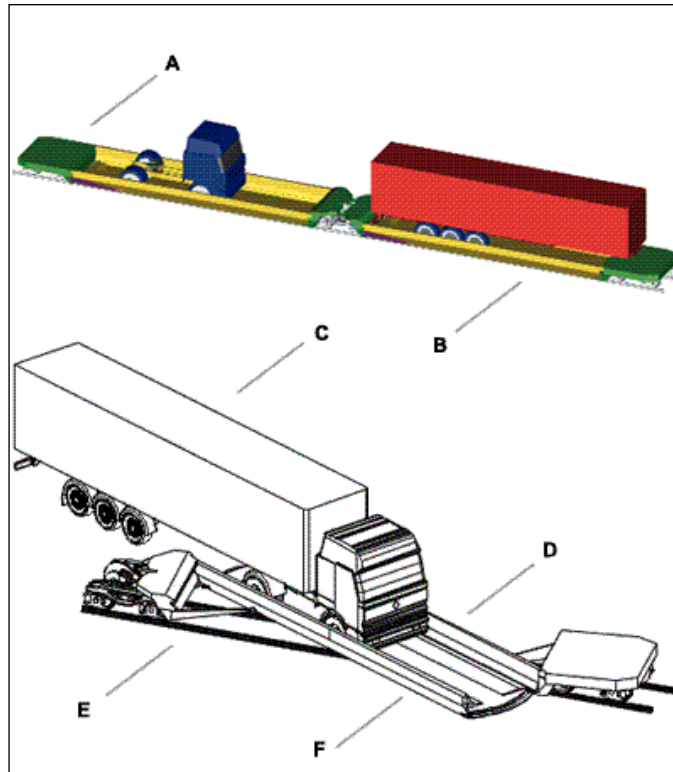

**Figure 3. Hupac's Rolling Highway Service.**

### **Modalohr**

A new entry in the intermodal world is Modalohr, which is innovative and has potential for both a rapid-load TOFC and land ferry service. This technology is under development in France and will be undergoing test runs over the next several years. Modalohr can provide TOFC and circus loading methods but significantly cuts down on loading times. Modalohr is a very low-profile railcar with a rotating platform, as shown in [Figure 4](#).

To load the car, the platform is rotated 45 degrees and the tractor and trailer are driven on. The tractor is detached from the trailer, and the platform is rotated back into position. The tractors can also be loaded onto another car, if desired. All of the cars can be loaded at one time, and there is no need for yard trucks to load the containers, as the delivering tractor can load or unload directly.



**Figure 4. Modalohr Concept Schematics.**

## **CURRENT INTERMODAL SERVICES IN TEXAS**

Class I railroad intermodal services have been growing consistently in the last years, despite the weak economy. The Intermodal Association of North America (IANA) reported that the second quarter of 2003 was the fifth consecutive quarterly gain of intermodal volume. Traffic grew in all key intermodal corridors, with an 11.3 percent growth from second quarter 2002 for the South Central-Southwest corridor. Railroads are receiving the benefits from aggressive marketing strategies, guaranteed transportation products, and expanded capacity. Class I railroads have been launching joint ventures with other railroads and motor carriers to offer a more reliable and consistent intermodal service. This section of the report describes the intermodal offerings by Class I railroads that serve Texas.

### **Union Pacific Railroad (29)**

Union Pacific Intermodal offers services to major domestic markets with an extensive intermodal terminal network, designed to serve as a critical interchange hub and loading/unloading terminal for rail intermodal shipments. In Texas, UP has intermodal ramps in

El Paso, San Antonio, Laredo, Dallas, and Houston, with a “paper ramp” in McAllen. The location of UP’s ramps is presented in [Figure 5](#).



**Figure 5. Union Pacific Intermodal Ramp Locations Map.**

This section will describe the domestic services and the services to Mexico in which UP participates and describes on the company website. Many of these services connect with an additional rail carrier, expanding the service either across the U.S. or by rail into Mexico and Canada.

### ***Domestic Services***

Union Pacific offers several domestic services.

**Cascade Connection.** The Cascade Connection serves the Interstate 5 corridor from Southern California to Vancouver, British Columbia. This is a pilot program in the Interstate 5 intermodal service corridor serving Los Angeles, California, in the south, and Portland, Oregon, and Seattle, Washington, in the north.

**Blue Streak.** The Blue Streak has been in operation for over 60 years as a premier train for the Cotton Belt, St. Louis Southwestern, and Southern Pacific railroads. It currently offers expedited intermodal service with three tiers of service:

### Superflyer

- Guaranteed on time or service is free
- Guaranteed equipment availability and condition
- Schedule with best cut off times and availability
- Proactive shipment monitoring

### Premium

- Priority access on the train; if cutoff is made, container will make the train
- Improved schedule with more favorable cutoff and availability times
- Proactive service monitoring; if freight is running behind, UP will inform of its status

### Standard

- Subject to next-day rolling
- Standard commitments
- Normal customer service

The Blue Streak has an intermodal terminal in Dallas, and the complete network is shown on [Figure 6](#).



Figure 6. Union Pacific Blue Streak Network.

**Premier Service between Chicago and Los Angeles.** This is an expedited third-day intermodal service with two levels of service between Los Angeles and Chicago. This truck like service uses Equipment Management Program (EMP), STAX, or private equipment services. EMP is a domestic interline container service offered by Union Pacific and Norfolk Southern, and STAX is a UP and CSXI cross-country container shipping service.

### ***Mexico Services***

Union Pacific offers three intermodal options to and from Mexico.

**Passport.** This is a seamless rail-truck ramp-to-door/door-to-ramp service in EMP's and rail trailers between specific U.S.-Canadian ramps and major Mexico markets via the Laredo gateway. Delivery and pick-up in Mexico is arranged by UP Carrier Services (UPCS) with an authorized Mexican motor carrier (AMMC). Passport simply means that a shipment is required to de-ramp at the border and present documentation to clear Customs before moving across the border.

**TransBorder.** This is a managed all rail and inbound product that bypasses congested border crossings and moves shipments in and out of Mexico faster and less expensively.

**Conventional.** The most popular plan combines rail movement north of the border on Union Pacific with an intermodal marketing company (IMC) or motor carrier south of the border, providing flexibility in transloading, consolidating, warehousing, or maintaining preexisting relationships with border vendors. This is a ramp-to-ramp service in containers or trailers, rail or private, between several U.S.-Canadian ramp points and Mexico gateways located at El Paso, Laredo, and McAllen, Texas, and Calexico, California.

### ***International (Ocean)***

For purposes of distinguishing international containerized shipments in the U.S. from domestic shipments, Union Pacific defines international as U.S. rail traffic involving an immediately prior or subsequent ocean movement. [Figure 7](#) presents UP's international intermodal network.



## Union Pacific International Intermodal Service



Figure 7. Union Pacific International Intermodal Service.

### Burlington Northern Santa Fe (30)

BNSF railway operates one of the largest intermodal networks in North America and customizes, designs, and even guarantees consistent transportation services to meet intermodal requirements. BNSF's intermodal network is shown in Figure 8, and BNSF hub facilities in Texas are located in Alliance (Dallas-Fort Worth), Amarillo, El Paso, and the Port of Houston.

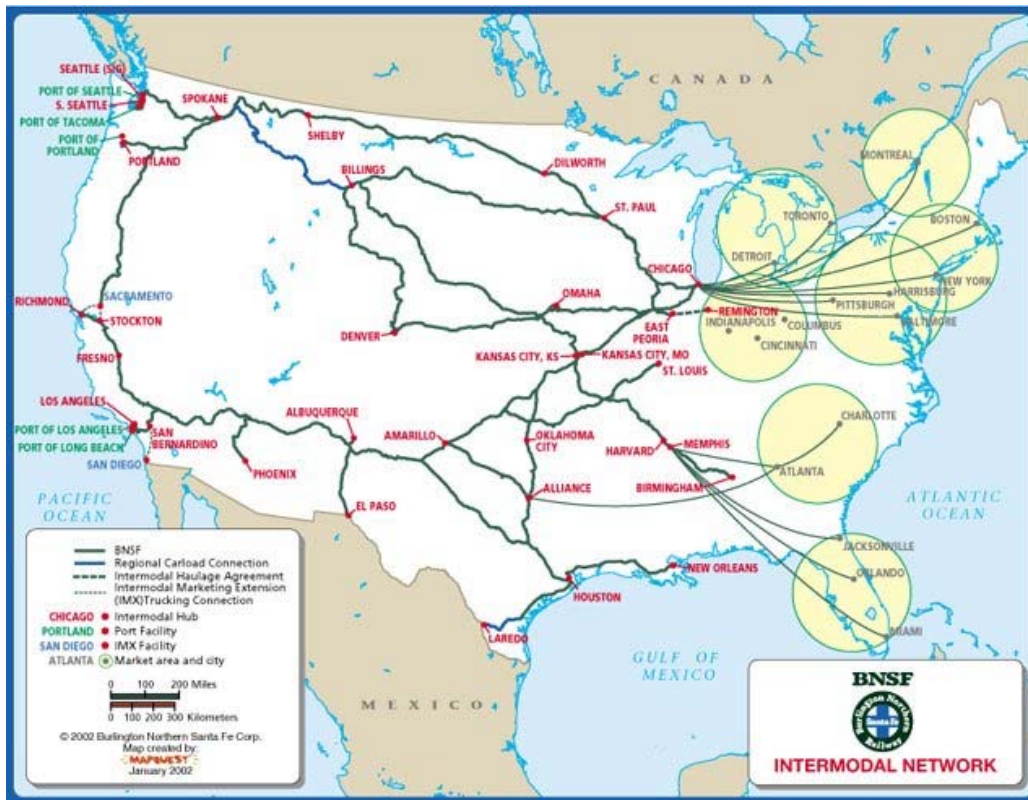

**Figure 8. BNSF's Intermodal Network.**

BNSF provides the following intermodal service level options:

- *E (Expedited)* – For extremely time-sensitive shipments, this provides the fastest service available, which is competitive with 900-mile-per-day over-the-road, team-driver service.
- *P (Premium)* – This truck-competitive service for trailers or containers supplies premium train service comparable with 500-mile-per-day or single-driver truck service.
- *N (No weekend availability)* – This is a premium train service for trailers or containers offering weekday (Monday-Friday) availability at the destination.
- *V (Value)* – This is a service in selected markets to address fluctuating supply and demand needs.
- *Y (Empty)* – Train service provided for the movement of empty containers or trailers.

BNSF offers several domestic and Mexico-related intermodal services.

**Guaranteed Service**

BNSF and Norfolk Southern (NS) have teamed up to offer coast-to-coast guaranteed intermodal service deliveries. BNSF offers a 100 percent on-time guarantee for intermodal shipments between Alliance and Chicago, Richmond, San Bernardino, and Stockton.

**Ramp-to-Ramp to and from Mexico via El Paso**

BNSF, CSXI, and Ferrocarril Mexicano (FXE) have expanded the North American Container Service (NACS) network to include service to and from Mexico via El Paso. This offer includes service between selected ramps in the U.S. and the ramps at Pantaco (Mexico City) and Guadalajara. The services are available to and from the U.S. ramps in [Table 6](#).

**Table 6. U.S. NACS Intermodal Ramps.**

▪ Atlanta	▪ Evansville	▪ Orlando	▪ Springfield
▪ Baltimore	▪ Ft. Lauderdale	▪ Philadelphia	▪ Syracuse
▪ Boston	▪ Jacksonville	▪ Richmond	▪ Tampa
▪ Charleston	▪ Los Angeles	▪ St. Paul	▪ Worcester
▪ Chicago	▪ Miami	▪ Savannah	
▪ Cleveland	▪ Nashville	▪ S. Kearny	

**Mexi Modal**

Mexi Modal is an intermodal service offered by BNSF in which carriers from Canada and Mexico participate, offering a truck-competitive, seamless transportation option into and out of Mexico. The carriers that participate with BNSF are:

- Canadian National (CN),
- CSX Intermodal,
- Ferrocarril Mexicano, and
- Transportacion Ferroviaria Mexicana (TFM).

Mexi Modal services are offered via Laredo with TFM in the Midbridge or MexiStack options, or via El Paso with FXE in the InterWest alternative.

The Midbridge product mirrors how most transborder truck transportation into and out of Mexico occurs today and allows the purchase of products to occur at the “middle of the bridge” between Laredo, Texas, and Mexico. Midbridge allows freight to be moved in containers by rail in the U.S. and by truck in Mexico.

The Laredo product allows movements of full truckload freight from the United States by rail either to or from a designated warehouse in Laredo, enabling shippers to store freight in Laredo for warehousing.

MexiStack is an all-rail, door-to-door product that enables the purchase of goods to occur at the United States or Mexico origin or destination. The freight is moved in containers by CSXI together with BNSF in the United States and by TFM in Mexico. The Mexi Modal network is shown in [Figure 9](#).



**Figure 9. Mexi Modal Network.**

## **Kansas City Southern (31)**

Kansas City Southern Railway (KCS) offers two main intermodal services: the Meridian Speedway and the North American Free Trade Agreement (NAFTA) Express.

### ***Meridian Speedway***

In 1995 KCS initiated run-through intermodal service between Meridian, Mississippi, and Alliance, Texas, on its Meridian Speedway. That operation was expanded in 1997 with the implementation of a voluntary coordination agreement (VCA) designed to promote manifest traffic volume on the route. The VCA offers Norfolk Southern shippers run-through service accessing Dallas and Mexico while avoiding congested Memphis and New Orleans gateways.

In March of 1998, KCS and NS opened a newly constructed joint intermodal facility in Port Arthur, Texas, to service the Port Arthur/Beaumont/Houston, Texas, Gulf Coast region.

### ***NAFTA Express***

NAFTA Express offers time-definite intermodal service to and from Laredo or all the way to Mexico City. NAFTA Express offers an alternative to costly, time-consuming over-the-road service. Southbound shipments de-ramping or northbound shipments ramping in Laredo take advantage of NAFTA Express service through Texas Mexican Railway's Laredo intermodal facility, Serrano Yard.

## **SHORT-HAUL INTERMODAL**

The current intermodal services listed in the above [section](#) either extend the length of the railroad's system or continue, through partnerships, over another railroad. This means intermodal movements typically extend beyond 1000 miles, even exceeding 2000 miles for some West Coast-East Coast transcontinental movements. The term short-haul intermodal generally focuses on movements less than 700 miles. At these distances competition with trucking is very strong, but railroads see this market as having growth potential. Jim McClellan, Senior Vice President of Planning at NS indicates that if the railroads want to grow business "it means taking on truckers in short-haul markets (32)."

To implement successful short-haul intermodal services is a very big challenge for the railroads. Several factors contribute to the success of short-haul intermodal. The first is intermodal produces small margins, so the short-haul service requires large volumes to cover the

relatively small margins. The product needs to provide truck-like service, including highway-competitive transit times and high service delivery performance. Shippers depend on extremely high levels of reliability for truck services, so the railroad will have to meet these standards for success. These levels are contradictory to existing perceptions of historic rail performance. In order to develop highly reliable, truck-like performances, the rail corridor needs to be high-speed, high-capacity routes directly connecting major markets.

Terminals also contribute to the success of short-haul intermodal services. Drayage is a major cost component of intermodal shipments, so drayage costs need to be minimized for short-haul intermodal. The terminals for short-haul intermodal services need to be well placed in order to create shorter drays. Services directly to and from ports would remove the drayage costs for one end of the service, thus greatly reducing that cost component. Terminal operations need to be fast, in order to facilitate highway-competitive transit times.

There are many examples in the U.S. and Canada of short-haul intermodal services, ranging from shuttle services, such as the Alameda Corridor, or truck-like services, such as CP's Expressway. The following include a few notable short-haul intermodal services.

### **Florida East Coast Railroad**

The Florida East Coast Railroad (FEC) operates from Miami to Jacksonville, where it interchanges with both NS and CSX. In conjunction with NS, FEC operates the Hurricane Train between Atlanta, Jacksonville, and Miami, a total distance of 650 miles. The seven-day-a-week run-through service provides next day service from Jacksonville to Miami, and second morning delivery from Atlanta with service performance of 26 hours, both of which are highly competitive with truck-transit times (33).

### **Norfolk Southern**

Norfolk Southern offers multiple short-haul services, including domestic retail service utilizing their Triple Crown subsidiary. Two major short-haul successes for NS include services between Atlanta and the ports of Charleston, South Carolina and Savannah, Georgia. The direct connection removes the dray penalty at the port locations, thus making these short routes a more economically viable option. The highway distance between Charleston and Atlanta is 320 miles, while the distance between Savannah and Atlanta is only 249 miles, making these extremely short for rail intermodal (34).

Norfolk Southern's preferred competitive tool for short-haul traffic is their Triple Crown RoadRailer technology, which was previously described in this chapter. The Triple Crown service operates an extensive retail network, according to Jim McClellan, including operations in Canada, U.S., and Mexico. The vital component of the service is that it is a door-to-door, one price, one point of contact service utilizing standard truck trailers modified to operate on rail lines. According to Mr. McClellan, the Triple Crown service "looks like, smells like, and acts like a truck (34)."

### **Canadian Pacific**

For Canadian Pacific, short-haul does not mean directly competing against trucking but partnering with trucking companies to provide the line-haul portion of the motor carriers' trip. This provides benefits to the trucking companies and fleet owners by saving on tractor investments, driver availability and costs, and fuel and maintenance expenses. The Expressway product covers the Toronto-Montreal-Detroit corridor and represents a non-traditional TOFC service with dedicated terminals and trains. The roll-on/roll-off loading and unloading technology, previously described in this chapter, allows for the transport of non-reinforced trailers by the railroad, thus expanding the available customer base. The 24-hour-a-day service has the capabilities of transporting 90 trailers per train and utilizes consistent market-driven schedule service, highway-competitive transit times, and superior service delivery performance of around 95 percent (35).





## **CHAPTER 4: KEY TEXAS TRANSPORTATION CORRIDORS**

Texas' central location in the U.S., its proximity to Mexico, and its seaport connections along the Gulf Coast create highly utilized trade corridors across the state. Many of these corridors include both highways and rail lines that extend to major domestic and international markets. This chapter provides a description of many of the major trade corridors in the state, including those designated by state or federal agencies, those identified by freight movement patterns, and those proposed for future development.

### **FEDERALLY DESIGNATED CORRIDORS**

Recent federal legislation has undertaken the process of identifying major corridors around the country that extend through multiple states and are important to future freight and passenger movements. This section describes the federally designated high-priority highway corridors and the high-speed rail corridors that connect major markets around the country.

#### **National Highway System High-Priority Corridors**

Originally developed under the Intermodal Surface Transportation Efficiency Act of 1991 (ISTEA) and expanded under the Transportation Efficiency Act for the 21<sup>st</sup> Century (TEA-21), 43 high-priority corridors were designated in the U.S. These corridors represent major trade corridors.

Texas is the location of several international border crossings and major trade corridors. In total, six high-priority corridors pass through Texas. These are shown in [Figure 10](#). Only Corridor 3 through the Texas Panhandle does not directly connect at a Texas-Mexico border crossing. The following five connect at border crossings:

- Corridor 27 – El Paso,
- Corridor 38 – Del Rio and Eagle Pass,
- Corridor 23 – Laredo,
- Corridor 20 – Laredo, and
- Corridor 18 – McAllen and Brownsville.

Combined Corridors 18 and 20 make up the proposed Interstate 69, and Corridor 38 represents the Ports-to-Plains Trade Corridor. Each of these routes is currently under consideration for

future development. Corridor 23 corresponds to Interstate 35 and was studied in a multistate project examining proposed improvement alternatives.



**Figure 10. Federally Designated High-Priority Corridors.**

### High-Speed Rail Corridors

A provision of the 1991 federal ISTEA legislation allowed the U.S. Department of Transportation (U.S. DOT) to designate up to eight rail corridors throughout the U.S. as locations where high-speed rail (HSR) would potentially be developed. TEA-21 expanded the number of corridors from eight to 11. The ISTEA legislation also authorized a special program for funding at-grade crossing hazard mitigation and other safety improvements along the designated corridors. For example, the most recent program allocations provide \$5.22 million in grants to 10 states along five HSR corridors. The U.S. DOT indicates that since 1993, this program has “resulted in improvements to nearly 330 highway-rail crossings, the closure of 122 highway

grade crossings, and aided in the design and construction of 12 grade separation projects (36)”. To date, Texas has not received significant funding from this program.

There are currently two federally designated HSR corridors within the state of Texas. The Gulf Coast Corridor was first designated in 1998. The Texas portion of this corridor includes the Union Pacific “Sunset Line” between Houston and the Louisiana border via Beaumont. This corridor links Houston to the more extensive routes in the states of Louisiana, Mississippi, and Alabama. Extensions to Georgia and Florida have also been added since it was first designated, as shown in Figure 11.



**Figure 11. Designated High-Speed Rail Corridors Located in Texas.**

The second HSR corridor in Texas is the South Central Corridor. This corridor was designated in 2000 and includes lines in Texas, Oklahoma, and Arkansas. The Texas portion of the corridor roughly parallels Interstate 35 between San Antonio and the Dallas-Fort Worth area. From Dallas, the route continues on to Texarkana, where it connects to Arkansas section ending in Little Rock. The Oklahoma portion of the route connects Tulsa and Oklahoma City to Dallas-Fort Worth via Gainesville. In 2003, TxDOT submitted a request to the Federal Railroad Administration to add an extension to the existing South Central Corridor that would extend from the Killeen-Temple area to Houston via Bryan-College Station—effectively connecting the two previously existing corridors and linking the major urban areas of the state. This extension

request was not approved, due to changes in U.S. DOT and FRA policy that encourage an increased role for states in developing and funding new passenger rail corridors.

## **FREIGHT ANALYSIS FRAMEWORK**

The Freight Analysis Framework (FAF) is a tool developed by the FHWA to understand freight demands, assess implications for the surface transportation system, and develop policy and program initiatives to improve freight efficiency (37). The FAF estimates trade flows on the nation's infrastructure in order to identify locations of capacity concerns. The FAF utilizes a base data year of 1998 and projects volumes for the years 2010 and 2020. The transportation modes incorporated into the tool are highway, railroad, water, and air.

The association of the trade flows with the infrastructure allows for the analysis of major trade corridors across the country. The following two figures display the current and projected truck volumes across the U.S. Examining the 1998 truck flows in [Figure 12](#) shows that major flows occur in the eastern portion of the U.S., along the California coast, and from Texas to the east. The majority of the truck flows in Texas occur in the metropolitan areas and in the Texas Triangle between Dallas-Fort Worth, San Antonio, and Houston along Interstates 35, 45, and 10. The major flows between Texas and other states exist on Interstate 40 through the Panhandle's Interstates 20, 30, and 35 from Dallas toward the north and east, and Interstate 10 between Houston and New Orleans. For 1998, the urban areas are the only locations with volumes greater than 10,000 trucks per day.

[Figure 13](#) shows the anticipated daily truck volumes for year 2020 across the U.S. A much higher percentage of the country's infrastructure is projected to carry at least 10,000 trucks on a daily basis. Where these locations were only in urban areas of Texas, they are anticipated to occur over the entire segments of the Texas Triangle and most of the interstate highways crossing into Texas. The anticipated growth in truck volumes will also result in significant numbers of trucks along the rural sections of Interstates 10 and 20 from El Paso to San Antonio and Fort Worth and international connections to Laredo, McAllen, and Brownsville. The map also displays the significant transcontinental corridors across the country.

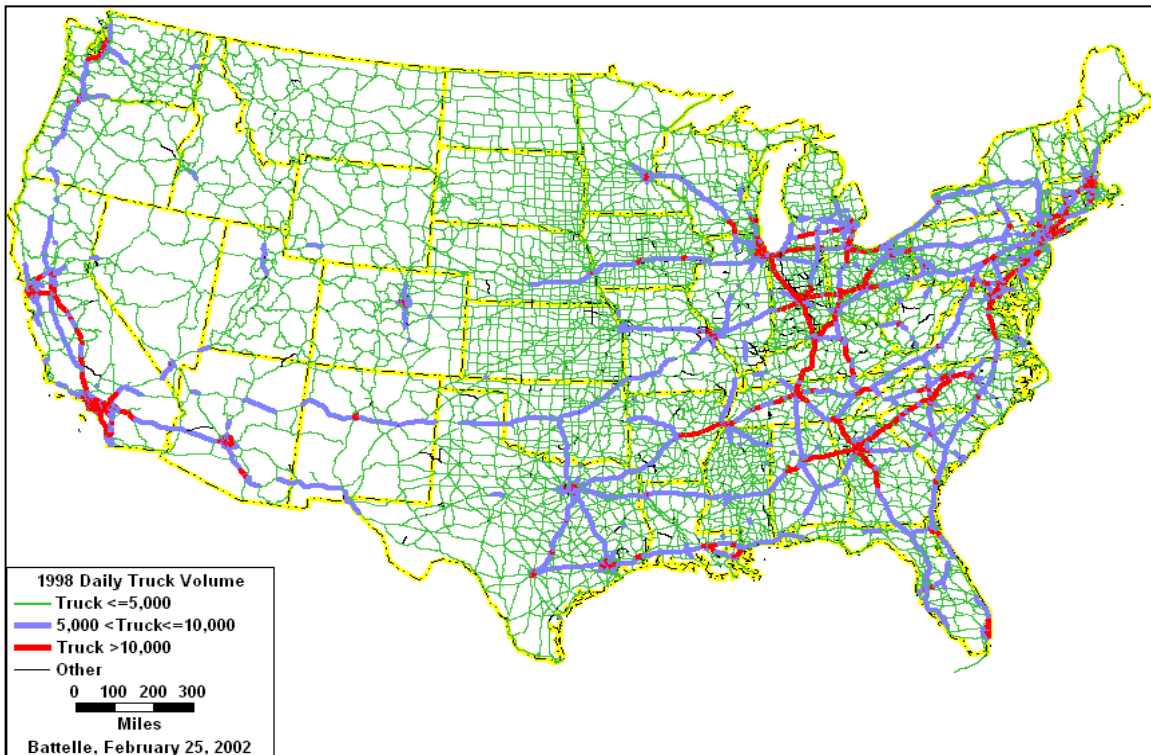

**Figure 12. 1998 Daily Truck Volume from the Freight Analysis Framework (37).**

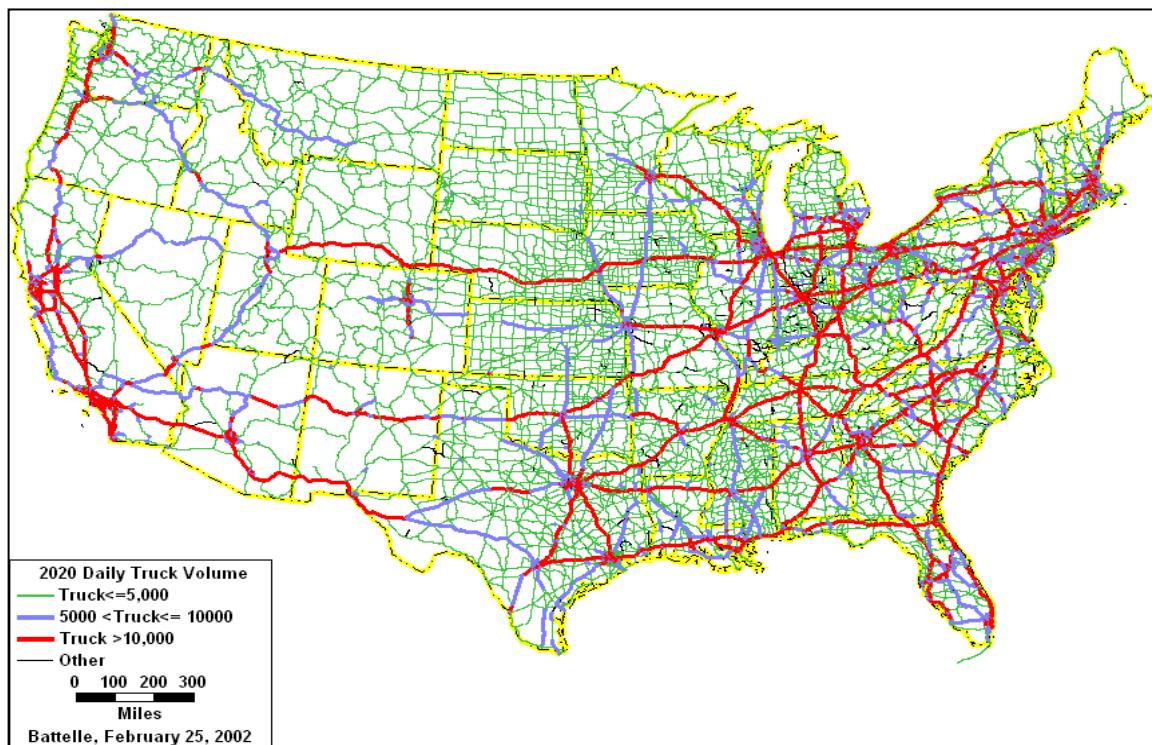

**Figure 13. 2020 Daily Truck Volume from the Freight Analysis Framework (37).**

FHWA also utilizes the FAF to create flow maps of the rail movements across the U.S. [Figure 14](#) displays the total U.S. rail flows for the year 1999. The rail flows are generally associated with major port and border locations. In Texas, the most significant corridor exists between Houston and the Dallas-Fort Worth region. Several additional high-volume corridors connect with the Dallas area.



**Figure 14. Total U.S. Rail Flows, 1999 (37).**

The results of rail volumes only originating and/or terminating within Texas are displayed in [Figure 15](#). The dominant flow reaches from the Midwest through the Dallas-Fort Worth region and down to Houston. This lane is explained by the coal movements originating in Wyoming and major movements to Kansas City and Chicago. Also notable are the movements between the West Coast and Texas along UP's Sunset Route and BNSF's Transcon Line from Los Angeles to Chicago, which passes through Texas' Panhandle. Traffic from this line destined for Texas connects at Amarillo before traveling to Fort Worth.

The international movements to Laredo are also pronounced in [Figure 15](#). Both the UP line from San Antonio and the Texas Mexican Railway line from Corpus Christi have flows of five million to 20 million tons.

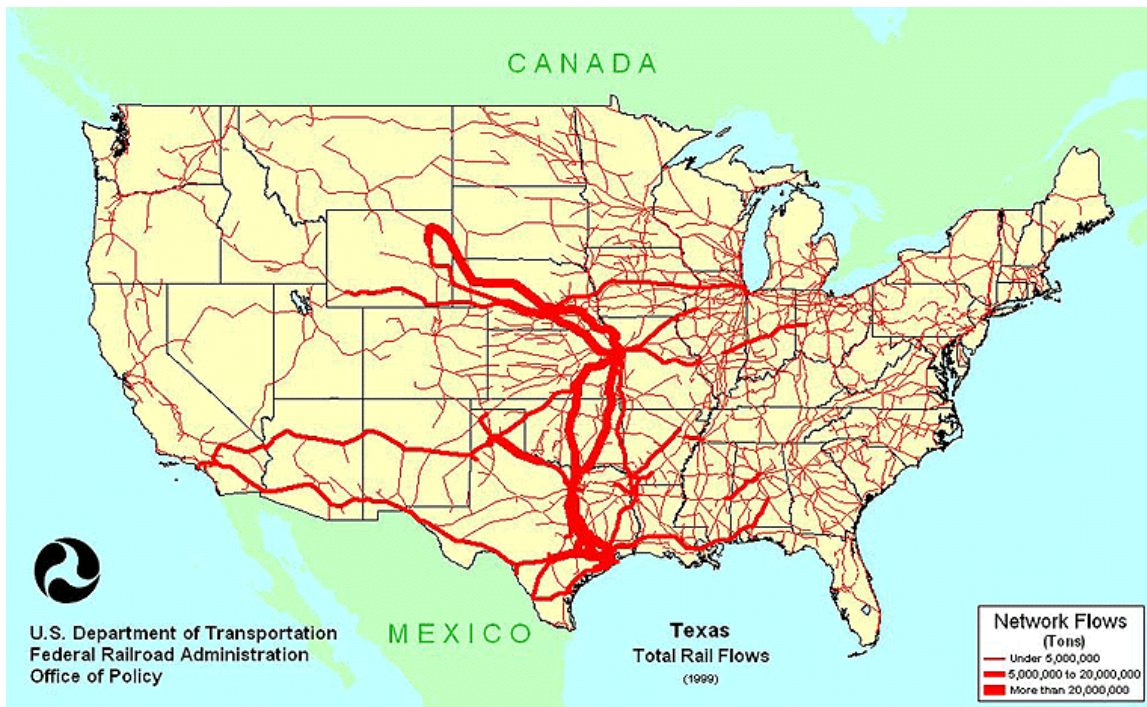

**Figure 15. Freight Flows to, from, and within Texas by Rail, 1999 (38).**

## **FUTURE CORRIDOR DEVELOPMENT IN TEXAS**

The picture of future transportation in Texas will be greatly affected by current state and federal concepts of moving people and goods. This section provides an overview of several corridor concepts for Texas.

### **Trans Texas Corridor**

The Trans Texas Corridor plan released in June 2002 proposes a 4000-mile corridor system entailing 1200-ft wide rights-of-way. Each corridor will contain separate highway lanes for passenger vehicles and trucks, high-speed passenger and freight rail lines, and dedicated utility zones.

The vision of the Trans Texas Corridor is to provide a faster and safer transportation network for the movement of people and goods. There are several identified positive impacts the corridor will have on the state.

- It will relieve congestion in the major metropolitan areas.
- It will increase safety by routing hazardous materials away from highly populated areas.
- It will generate toll revenue to further improve Texas' transportation system.

- It will stimulate economic growth (39).

With these in mind, four corridor segments have been designated as priority segments for their potential ability to maximize the benefits:

- Denison to the Rio Grande Valley parallel to Interstate 35, Interstate 37, and the proposed Interstate 69;
- Texarkana to Houston to Laredo along the proposed Interstate 69;
- Houston to Dallas-Fort Worth parallel to Interstate 45; and
- El Paso to Orange parallel to Interstate 10.

Figure 16 displays the proposed Trans Texas Corridor, with priority corridors identified in red.



Figure 16. Proposed Trans Texas Corridor (39).



## Interstate 69

Considered the NAFTA Highway, Interstate 69 will connect Mexico with Canada through eight U.S. states, including Texas. The Interstate 69 states, the states using Interstate 69, and its border crossing ports account for nearly 63 percent of the total U.S. truck-borne trade with Canada and Mexico (40). The development of Interstate 69 will occur along the combination of two federally designated high-priority corridors: Corridor 18 and Corridor 20. In Texas, Interstate 69 will travel from Texarkana to the Rio Grande Valley, where branches stretch to the border crossings of Laredo, McAllen, and Brownsville. Figure 17 shows the proposed Interstate 69 route in Texas.



Figure 17. Proposed Interstate 69 Corridor (41).

## Ports-to-Plains Trade Corridor

In TEA-21 the Ports-to-Plains corridor was designated as high-priority Corridor 38. Driven by the tremendous NAFTA-related trade volumes, the Ports-to-Plains corridor will connect Mexico to Denver, Colorado, through west Texas, the Texas Panhandle, New Mexico, Oklahoma, and Colorado. Figure 18 shows the proposed Ports-to-Plains routes from Denver to the Texas-Mexico border.



## CHAPTER 5: PROJECT SELECTED CORRIDORS

The previous [chapter](#) described the many identifiable corridors within Texas. The most significant corridors revolve around the movement of freight along the interstate highways and major rail routes, particularly those related to international movements.

Successful intermodal services depend on reliable service levels and competitive costs associated with the movement from the origin to the destination. The focus of this project is to identify corridors with enhanced intermodal services, the use of which could reduce truck traffic on highways. The three corridors selected are:

- Laredo to Dallas, involving Interstate 35 and Union Pacific Railroad;
- Houston to Dallas, involving Interstate 45 and Burlington Northern Santa Fe Railway; and
- El Paso to Dallas, involving Interstate 10-Interstate 20 and Union Pacific Railroad.

Each corridor represents different scenarios of enhancement options and different markets served. This chapter describes the selection criteria utilized in the selection process and the characteristics of the selected corridors.

### SELECTION CONSIDERATIONS

Texas has a robust transportation system that is used extensively for the movement of freight. In selecting three corridors for detailed analysis for this project, researchers used several criteria.

- multimodal in nature,
- high levels of traffic and truck volumes,
- currently utilized for intermodal purposes, and
- considered significant by the railroads.

### Multimodal Corridors

The selection process focused on corridors that provide both highway and rail transportation options between the identified market centers. In some instances, rail lines closely parallel the highway route, passing through virtually the same markets throughout the length of the route. In other instances, the rail line and highway may connect to the same origin and

destination but may vary in routing. Also, the rail route may consist of a direct route or may utilize several different segments, such as transferring from one subdivision to another along the route. For this project, the primary concern is the origin and destination markets without consideration of the intermediate markets. Therefore, either scenario is acceptable, given the origin and destinations are the same and the routes are not overly circuitous. In Texas, most of the corridors reviewed were multimodal in nature, consisting of both highway and rail couples.

### **Truck and Traffic Volumes**

The growth in the number of trucks transporting freight on Texas highways has grown significantly. Texas' position along many of the major trade routes between the U.S., Mexico, and Canada, along with the major seaports and inland commercial centers, has contributed to this growth. Truck traffic, combined with the significant growth in automobile traffic along the major highways is resulting in increasing levels of roadway congestion. Along with the development of suburban communities, congestion is becoming one of the highest concerns in urban transportation and municipality planning. This project focuses on those routes that contain high levels of truck traffic along the entire stretch of the corridor and that will benefit from the removal of trucks that traverse the entire corridor from the highway system.

### **Intermodal Facilities and Services**

One major consideration for providing intermodal service along a corridor is the operation and availability of existing intermodal services and terminals for the truck-to-rail transfer. Three of the seven U.S. Class I railroads operate in Texas and maintain intermodal facilities. [Chapter 3](#) of this report discussed the many intermodal services currently offered in the state. For the selection process, researchers examined the corridors identified in [Chapter 4](#) for the existence of the development of intermodal facilities and services.

### **Railroad Interest**

A Public-Private Intermodal Partnership will not be successful without the interest and cooperation of the railroads. In Texas, the Class I railroads are Union Pacific Railroad, Burlington Northern Santa Fe Railway, and Kansas City Southern Railway. Just as with any business, the railroads continuously examine their business for ways to improve productivity without any added burdens, such as long-term debt or commitments. Two ways to develop

enhanced intermodal services are to target either highly utilized lines that would benefit from infrastructure improvements or underutilized lines with excess capacity. The research team employed direct communication with the Texas railroads for this criterion.

## **LAREDO TO DALLAS CORRIDOR: INTERSTATE 35 – UNION PACIFIC RAILROAD**

### **Corridor Overview**

The Laredo to Dallas corridor represents one of the most significant north-south trade corridors in the United States. Interstate 35 is the only interstate highway that connects Mexico and Canada and passes through the Midwest, linking the metropolitan areas of San Antonio, Austin, Dallas-Fort Worth, Oklahoma City, Kansas City, Minneapolis-St. Paul, and Duluth. National trade corridor flows indicate Interstate 35 carries some traffic along the entire length between Mexico and Canada but, more importantly, acts as a collection basin for locations along the Eastern U.S. traveling to and from Mexico. In Texas, the Interstate 35 segment represents the fastest growing population area in the state, with the metropolitan areas of Laredo, San Antonio, San Marcos, Austin, Temple, Waco, and Dallas.

In 2001, surface trade valued at over \$79 billion moved through the Laredo gateway, ranking it second to Detroit in total U.S.-North American land trade and first in U.S.-Mexico land trade. The majority of that land trade travels by truck and rail. Incoming trucks through the Laredo gateway totaled 1.4 million crossings, while incoming rail movements totaled almost 274,000 crossings. On a daily basis 3800 truck and 750 rail incoming crossings take place through the Laredo gateway (43).

The Union Pacific Railroad is the only carrier to maintain rail routes over the Laredo to Dallas corridor. The San Antonio to Laredo route segment consists of one mainline segment. The Dallas to San Antonio route segment consists of multiple routes of rail infrastructure over several subdivisions. Operationally, this allows UP to distribute train movements directionally over parallel routes, thus increasing capacity.

Figure 19 shows the Laredo to Dallas corridor which includes Interstate 35 and the UP rail lines.

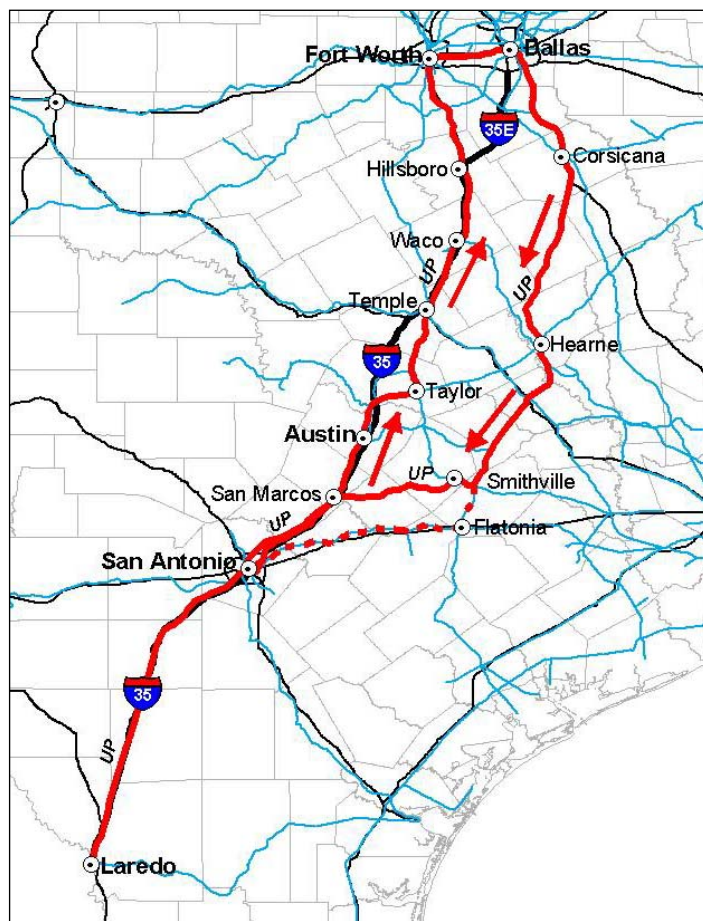

**Figure 19. Laredo to Dallas Corridor.**

For the corridor, Interstate 35 is designated as National Highway System High-Priority Corridor 23, and between San Antonio and Dallas-Fort Worth is designated as part of the South Central High-Speed Rail Corridor. The Trans Texas Corridor plan indicates a priority corridor paralleling Interstate 35 from the Texas-Oklahoma border north of Dallas to the San Antonio area before extending south to the Texas-Mexico border.

### **Highway Characteristics**

The FHWA Freight Analysis Framework data provide information related to segment properties, average daily traffic levels, volume-to-capacity levels, and average daily truck levels. [Table 7](#) shows that 58.5 percent of the corridor resides in rural portions of the state, while the remaining portions reside in small or large urban areas. The segment from San Antonio to Hillsboro, where Interstate 35 splits with branches to Fort Worth and Dallas, is substantially urban (61 percent) in nature compared with other segments.

**Table 7. Laredo to Dallas Corridor Mileage Analysis.**

Corridor Segment	Total	Large Urban	Percent	Small Urban	Percent	Rural	Percent
I35 Laredo-SA	153.3	23.0	15.0	0.0	0.0	130.3	85.0
I35 SA-Hillsboro	214.3	86.0	40.1	45.3	21.2	83.0	38.7
I35E Hillsboro-Dallas	47.3	6.5	13.8	11.3	23.8	29.5	62.4
Total	414.9	115.5	27.8	56.6	13.6	242.8	58.5
Large Urban = 50,000 or greater; Small Urban = 5,000-49,999; SA – San Antonio							

The urban influences along the Interstate 35 segment north of San Antonio is reflected in the total traffic volumes displayed in [Table 8](#), which is three times more than the Laredo to San Antonio segment and over twice as much as the Hillsboro to Dallas segment. The traffic volumes are not expected to approach the capacity levels over the entire corridor until 2020 mostly because of the inclusion of Laredo to San Antonio segment. The San Antonio to Hillsboro segment was approaching capacity in 1998 and is expected to reach a volume-to-capacity ratio of 1.47 in 2020. The most northern segment’s volume-to-capacity ratio is projected to be 1.05 in 2020.

**Table 8. Laredo to Dallas Corridor Traffic Volumes and Capacity Levels.**

Corridor Segment	Segment Length	Average AADT			Average V/C Ratio		
		1998	2010	2020	1998	2010	2020
I35 Laredo-SA	153.3	28,812	38,882	46,473	0.29	0.41	0.49
I35 SA-Hillsboro	214.3	96,706	125,171	142,460	0.98	1.31	1.47
I35E Hillsboro-Dallas	47.3	42,933	56,307	65,266	0.67	0.91	1.05
Total	414.9	56,150	73,454	84,733	0.65	0.87	1.00
AADT – Average annual daily traffic; V/C Ratio – Volume-to-Capacity Ratio							

Two forms of truck traffic along the corridor are presented in [Table 9](#). The first set of values represents the average average annual daily truck traffic (AADTT) for each segment and the entire corridor. In 1998 the San Antonio to Hillsboro segment experienced the greatest level of trucks with over 8700 daily, while the Laredo to San Antonio segment had 4100 trucks per day. The projected values result in similar truck levels over the entire corridor. The Hillsboro to Dallas segment is projected to experience the greatest levels with almost 13,000 trucks per day. The Laredo to San Antonio segment is projected to grow to 9900 trucks per day.

**Table 9. Laredo to Dallas Corridor Truck Volumes.**

Corridor Segment	Segment Length	Average AADTT			Average FAF		
		1998	2010	2020	1998	2010	2020
I35 Laredo-SA	153.3	4,182	7,355	9,904	2,830	5,453	7,424
I35 SA-Hillsboro	214.3	8,726	12,551	11,830	6,040	8,772	6,903
I35E Hillsboro-Dallas	47.3	7,613	11,095	12,823	4,462	6,664	7,045
Total	414.9	6,840	10,333	11,519	4,444	6,963	7,124
AADTT – Average annual daily truck traffic = all trucking units; FAF – Freight Analysis Framework truck traffic = 60,000-80,000 lb. units only							

Also shown in [Table 9](#) are the FAF truck volumes. This model-generated number represents the number of daily 60,000-80,000 pound truck units along the segment. These values are expected to significantly grow in the Laredo to San Antonio segment from 2800 trucks in 1998 to 7400 trucks per day in 2020. Over the entire corridor the FAF truck levels are expected to average 7100 trucks per day in 2020.

The Interstate 35 corridor is a significant player in NAFTA-related truck movements. According to the TxDOT report *Effect of NAFTA on the Texas Highway System* Interstate 35 carries 31.6 percent of all NAFTA trucks (44).

### Rail Route Characteristics

Union Pacific Railroad operates the rail corridor between Laredo and Dallas. The 150-mile route segment from Laredo to San Antonio is a single mainline, while the route from San Antonio to Dallas consists of two separate rail line routes utilizing directional running. From San Antonio, northbound shipments travel over a distance of approximately 310 miles through San Marcos, Austin, Waco, and Fort Worth before reaching Dallas. The southbound shipments from Dallas travel over a distance of approximately 335 miles through Corsicana, Hearne, Smithville, and San Marcos. An additional southbound route travels to Flatonia, where trains connect to UP’s heavily traveled Sunset Route over to San Antonio.

The stretch between San Antonio and San Marcos consists of two separate parallel lines: one formerly owned by Missouri Pacific Railroad (MP) and the other formerly owned by the Missouri Kansas Texas Railroad (MKT). Restored operations over the MKT line occurred in 1998 when UP spent \$15.7 million to rehabilitate the 17 miles between San Marcos and San Antonio (45). Track improvements over the MP rail line included a \$6.8 million project in 2001 for cross tie and rail upgrades from New Braunfels to Austin (46).



Union Pacific implemented directional running after the merger with Southern Pacific over several areas of their network where each entity possessed parallel routes. In addition to operations between Dallas and San Antonio, the major corridor between Laredo, St. Louis, and Chicago has southbound traffic traveling on the former Southern Pacific route and northbound trains on the parallel UP route (47). Operating on parallel lines directionally eliminates oncoming train conflicts and increases operational efficiency.

Union Pacific operates intermodal facilities in Laredo, San Antonio, and Dallas. The current Laredo facility, Port Laredo, opened in 1990 and handles both railroad operations and railcar inspections. Union Pacific estimates a \$40 million total investment in the Port Laredo facility since its construction. That value includes initial costs and periodic improvements and upgrades. The last major improvements to the facility occurred in 2001 and 2002. The continued growth in international traffic motivated UP to invest \$15.8 million to increase capacity and for facility improvements (48). With all the improvements to the facility since inception, the Port Laredo facility now consists of:

- six tracks for arriving and departing trains;
- 14 tracks used to sort railcars by destination;
- two tracks, and space under roof, to repair four railcars at a time;
- one track for locomotive fueling and inspection; and
- three tracks for intermodal use (48).

San Antonio intermodal operations exist at two facilities, with the major activities occurring at the South San Antonio (SoSan) Yard. Prior to the merger, both UP and Southern Pacific operated intermodal yards. The SoSan Yard was UP's ramp prior to the merger and exists near the former Kelly Air Force Base. Southern Pacific intermodal operations were maintained at the East Yard. For UP, the facilities in San Antonio play a major role in international movements by handling the staging activities for shipments to and from Mexico. Despite recent improvements to the SoSan Yard, including the addition of two new departure tracks and the extension of four yard tracks, UP feels additional capacity improvements and investment would improve service to the border (49).

Union Pacific operates two intermodal facilities in the Dallas area. The Miller Yard in Dallas is a 68-acre ramp with six working tracks approximately 1200 feet in length each. This

facility performs 14,000 to 15,000 lifts per month values considered at or near capacity (21). It is an older facility with constrained boundaries limiting future expansion.

The 130-acre Mesquite Yard houses only intermodal and automotive activities. This relatively new facility, originally constructed in 1980, benefited from a \$26 million expansion in 1998 that doubled yard capacity (21). The facility now has four working tracks approximately 5000 feet in length and a state-of-the-art automated gate system.

### **Laredo to Dallas Enhanced Intermodal Option**

The enhanced intermodal service for this 450-mile corridor is a sprint train service by UP between Laredo and Dallas. The six total trains per day service, three in each direction, would target both containers and trailers and operate 5000-6000 foot trains with 90 railcars. The projected infrastructure improvements necessary to implement such a service include upgrades to the facilities at both ends and the construction of a double track over the 150-mile segment between Laredo and San Antonio. The total estimated improvement costs are \$279 million. The expected per unit charge is \$500-\$600.

A service focusing on both trailers and containers with trains between 5000 and 6000 ft. in length would transport 90 trailers or 180 double-stacked containers per train, assuming full trains each trip. This would result in the removal of between 540 and 1080 trucks per day along Interstate 35. Operating 5 days per week, or 260 days per year, the number of trucks removed ranges between 140,400 and 280,800 trucks annually. Table 10 provides an overview of the intermodal service from Laredo to Dallas. The economic analysis of this corridor exists in Chapter 6, including the benefits accrued by the public and private entities.

**Table 10. Laredo to Dallas Corridor Intermodal Service.**

<b>Service</b>
<ul style="list-style-type: none"> <li>• Sprint Train between Laredo and Dallas</li> <li>• 3 trains per day in each direction</li> <li>• 5 days per week</li> </ul>
<b>Target</b>
<ul style="list-style-type: none"> <li>• Both Trailers and Containers</li> <li>• 90 cars per train: 90 trailers or 180 double-stack containers per train</li> </ul>
<b>Service Cost</b>
<ul style="list-style-type: none"> <li>• \$500 to \$600 per unit</li> </ul>
<b>Infrastructure Improvements</b>
<ul style="list-style-type: none"> <li>• Facility Improvements</li> <li>• Upgrade existing facilities on both ends</li> <li>• \$20-\$30 million per facility</li> <li>• Rail Line Improvements</li> <li>• Double track between Laredo and San Antonio: \$1.5 million per mile at 146 miles is \$219 million</li> <li>• Total Infrastructure Improvements add to \$279 million</li> </ul>

**HOUSTON TO DALLAS CORRIDOR: INTERSTATE 45 – BURLINGTON NORTHERN SANTA FE RAILWAY**

**Corridor Overview**

This corridor links Houston and Dallas, the fourth and eighth largest cities in the U.S., respectively. Houston’s proximity to the Texas Gulf Coast makes it a major generator of international freight traveling through the Port of Houston. The Houston area contains a high concentration of petrochemical and manufacturing industries. Dallas represents a major generator of freight, both inbound and outbound. It is often referred to as an “inland port” for its attraction of international goods, which then disperse throughout the U.S. Dallas’ geographic location also contributes to its role in transcontinental shipments.

This multimodal corridor linking Houston and Dallas analyzed for this project consists of Interstate 45 and the BNSF Teague line, as shown in [Figure 20](#). The BNSF route consists of a single direct line that parallels Interstate 45, although not closely. Mostly rural along most of the route once outside Houston’s suburban growth, Interstate 45 between Dallas and Houston is a vital freight movement connection. As one of the legs of the Texas Triangle, along with the Houston-San Antonio and Dallas-Fort Worth-San Antonio routes, Interstate 45 represents one of

the most used highways in Texas for truck movements. Perhaps because of this, the Trans Texas Corridor Plan designates the corridor as high priority.

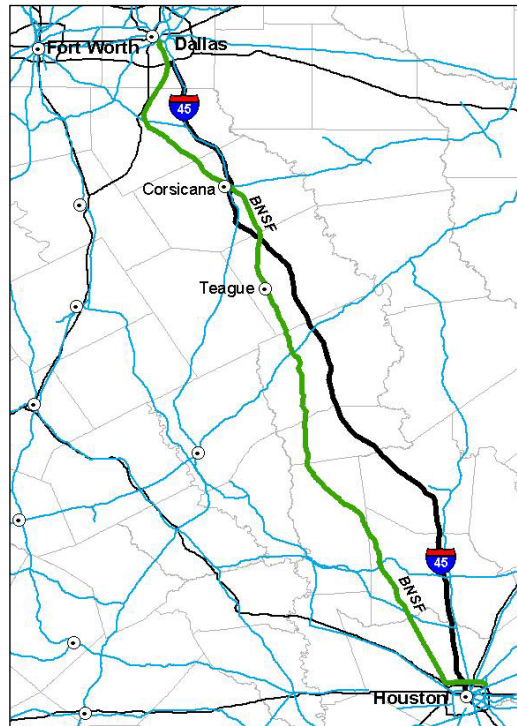

**Figure 20. Houston to Dallas Corridor.**

### Highway Characteristics

Interstate 45 travels approximately 225 miles between Houston and Dallas. Of this, 73 percent of the corridor is rural, 14 percent resides in populated areas between 5000 and 49,999, and the remaining 13 percent passes through large urban areas, as displayed in Table 11. These small urban areas are Conroe, Huntsville, Corsicana, and Ennis. The estimated travel time over the segment is four hours.

**Table 11. Houston to Dallas Corridor Mileage Analysis.**

Corridor Segment	Total	Large Urban	Percent	Small Urban	Percent	Rural	Percent
I45 Houston to Dallas	227.8	30.5	13.4	31.6	13.9	165.7	72.8
Large Urban = 50,000 or greater; Small Urban = 5,000-49,999							

Table 12 shows the average daily traffic levels and average volume-to-capacity ratio for the entire Interstate 45 corridor. Conditions for the base 1998 year indicate the roadway is below capacity with daily traffic of 75,000 vehicles. These levels will increase to over 109,000 daily vehicles in 2020, creating oversaturated conditions.

**Table 12. Houston to Dallas Corridor Traffic Volumes and Capacity Levels.**

Corridor Segment	Segment Length	Average AADT			Average V/C Ratio		
		1998	2010	2020	1998	2010	2020
I45 Houston to Dallas	227.8	75,602	96,206	109,555	0.78	1.00	1.12
AADT – Average annual daily traffic; V/C Ratio – Volume-to-Capacity Ratio							

Table 13 shows the truck levels along the entire Interstate 45 corridor for 1998, 2010, and 2020. The average AADTT numbers represent the number of all trucks on the corridor, which is projected to increase from 9400 in 1998 to 11,500 in 2020. The average FAF truck volumes represent the number of 60,000 to 80,000-pound trucks on the corridor. This model-generated number is projected to experience moderate growth from 1998 to 2020.

**Table 13. Houston to Dallas Corridor Truck Volumes.**

Corridor Segment	Segment Length	Average AADTT			Average FAF		
		1998	2010	2020	1998	2010	2020
I45 Houston to Dallas	227.8	9,467	11,549	11,360	7,658	9,004	8,041
AADTT – Average annual daily truck traffic = all trucking units; FAF – Freight Analysis Framework truck traffic = 60,000-80,000 lb. units only							

The Interstate 45 corridor is not a major player in NAFTA-related traffic. According to the TxDOT *Effect of NAFTA on the Texas Highway System* report, only 0.1 percent of NAFTA truck movements travel along Interstate 45 (44).

### Rail Route Characteristics

BNSF operations between Houston and Dallas-Fort Worth utilize two different routes: the Teague line from North Houston to Dallas and the Temple line from South Houston through Temple to Fort Worth. The most significant rail operations in the Dallas-Fort Worth area occur in Fort Worth at the Alliance Yard and intermodal facility. The shortest route in terms of

distance is the Teague route, which is approximately 245 miles from North Houston to Dallas. An additional 50 miles are required to reach the Alliance facility. The Temple route departs Houston on the south side and travels south to Alvin before traveling northwest through Temple to Alliance. The total trip length from South Houston to Alliance is 350 miles. Despite the distance advantage, the dominant traffic route between Houston and Dallas-Fort Worth is over the Temple line, mainly because of track conditions and operational restrictions in the Dallas area, along a Union Pacific track over which BNSF has trackage rights.

The current maximum operating speed along the Teague line is 40 mph, with some short sections relegated to speeds as low as 10 mph (50). The estimated travel time from Houston to Dallas is 7.5 hours, according to BNSF personnel (51). Train control along the route consists of automatic block signals (ABS) dispatched by track warrant control (TWC).

Traffic along the Teague line consists mainly of coal trains supporting electrical power plants at both ends, with little traffic destined for locations in the middle segments. Traffic density in 2002 was between 10 and 19.9 million gross ton-miles per mile (MGTM/Mi) (52).

Current intermodal movements by BNSF between the city pairs exist solely on the Temple route from the Pearland Intermodal Yard to the Alliance facility north of Fort Worth. BNSF does own an additional intermodal yard in Houston but is currently leasing it to an aggregate company. This 70-acre facility is located along UP's East Belt Subdivision in northeast Houston near the Pierce Yard, between Settegest and Englewood Yards. It signifies where Burlington Northern (BN) centered their intermodal operations in Houston prior to the merger with Atchison Topeka and Santa Fe Railway (ATSF) to form BNSF. Interestingly, according to the merger application, all BNSF intermodal activity was to be stationed at this location instead of the Pearland facility. They indicate the facility was in a "very good location relative to the market" but limited in expansion opportunities (53).

Previous intermodal operations between Houston and Dallas-Fort Worth included a service by BN as a component of a longer service to and from the Pacific Northwest. The Teague line was BN's link between Houston and Dallas-Fort Worth. If excess capacity was available on the Pacific Northwest-Houston train, then intermodal units originating or terminating in Dallas-Fort Worth would be added to the train. According to BNSF personnel, the Dallas-Fort Worth-Houston demand was greater than the excess train capacity, but it was too costly to run additional trains just to serve that market (54).

## **Houston to Dallas Enhanced Intermodal Option**

The intermodal service between Houston and Dallas by BNSF is a dedicated short-haul service focusing on reinforced and non-reinforced trailers or containers on chassis. The initial service level involves two trains per day in each direction, with each train capable of transporting a maximum of 120 units. Initial traffic levels are for each train to transport 85 trailers. Anticipated annual levels are 88,802 trailers in the first year and 131,056 trailers in the tenth year, with growth capped at year 10. BNSF plans to work directly with trucking companies in a partnership, where the trucking company would provide the transportation to and from the intermodal yard and BNSF would provide the line-haul portion of the trip. Operating five days a week, the service will include a morning service and an evening service, each taking nine hours ramp-to-ramp.

This dedicated service requires a total infrastructure and equipment investment of \$100.5 million. Infrastructure costs include line upgrades, which will improve speeds and reduce transit times from 7.4 hours to 5.0 hours. The existing former BN intermodal hub will act as the staging facility in Houston, while the Dallas area requires a new facility. The equipment costs include the eight dedicated locomotives and 104 dedicated “long runner” railcars capable of transporting up to three 57-ft trailers per car.

[Table 14](#) provides details and costs of the BNSF intermodal service between Houston and Dallas. An economic analysis of this corridor also exists in [Chapter 6](#), including the benefits accrued by the public and private entities.

**Table 14. Houston to Dallas Corridor Intermodal Service.**

<b>Service</b>
<ul style="list-style-type: none"> <li>• Dedicated short-haul intermodal service between Houston and Dallas</li> <li>• Direct partnership with trucking companies</li> <li>• 2 trains per day in each direction – morning and evening service</li> <li>• 9 hours ramp-to-ramp</li> <li>• 5 days per week</li> </ul>
<b>Target</b>
<ul style="list-style-type: none"> <li>• Trailers and containers on chassis</li> <li>• Initial levels: 85 trailers per train</li> <li>• Projected annual levels: 88,802 units in year 1; capped after 10 years at 131,056 units</li> </ul>
<b>Infrastructure Improvements and Equipment Costs</b>
<ul style="list-style-type: none"> <li>• Facility Construction/Improvements – \$38.5 million</li> <li>• New facility in Dallas – \$21 million</li> <li>• 32 acres</li> <li>• 7000-ft strip track &amp; 8000-ft storage track</li> <li>• 200 parking spaces</li> <li>• 3 lift devices</li> <li>• Upgrade existing facility in Houston at former BN Intermodal Hub – \$17.5 million</li> <li>• Rail Line Improvements – \$33.8 million</li> <li>• Increase speeds from 40 mph to 60 mph, which will reduce transit times from 7.4 hours to 5 hours</li> <li>• Equipment Costs – \$28.2 million</li> <li>• 8 dedicated locomotives</li> <li>• 104 dedicated “long runner” railcars – capable of transporting up to three 57-ft trailers on one railcar</li> <li>• Total Infrastructure and Equipment Costs – \$100.5 million</li> </ul>

**EL PASO TO DALLAS CORRIDOR: INTERSTATE 10-INTERSTATE 20 – UNION PACIFIC RAILROAD**

**Corridor Overview**

This corridor captures significant levels of transcontinental traffic from Los Angeles to the Midwest and East Coast and international traffic to and from El Paso. The highway portion consists of Interstate 10 from El Paso east to Kent, where Interstate 20 forms and bears northeast to Fort Worth and Dallas. Predominantly located in rural parts of Texas, the notably sized cities of Odessa, Midland, and Abilene reside along the route.

The UP rail line navigates the entire corridor, closely paralleling the highway segment. Composed of the Sunset Route from El Paso to Sierra Blanca and the Texas and Pacific (T&P)



line from Sierra Blanca to Fort Worth and Dallas, this line forms the central segment of the vital transcontinental operations from California to Memphis. The highway route also represents a major component of the cross-country movements between the West Coast and Texas and the Southeastern U.S. [Figure 21](#) shows the El Paso to Dallas corridor.



**Figure 21. El Paso to Dallas Corridor.**

### Highway Characteristics

The El Paso to Dallas corridor runs approximately 640 miles between El Paso and Dallas along Interstate 10 east to Kent and Interstate 20 to Fort Worth and Dallas. The corridor is mostly rural in nature, with the notable small urban areas consisting of Big Spring and Sweetwater. The large urban communities with populations over 50,000 include El Paso, Odessa, Midland, Abilene, Fort Worth, and Dallas. [Table 15](#) displays the mileage breakdown by small and large urban and rural areas, which make up 80 percent of the route.

**Table 15. El Paso to Dallas Corridor Mileage Analysis.**

Corridor Segment	Total	Large Urban	Percent	Small Urban	Percent	Rural	Percent
I10 EP-Kent	173.0	21.0	12.2	1.1	0.6	150.9	87.2
I20 Kent-FW	468.0	80.3	17.2	23.4	5.0	364.4	77.9
Total	641.1	101.3	15.8	24.4	3.8	515.3	80.4
Large Urban = 50,000 or greater; Small Urban = 5,000-49,999; EP – El Paso; FW – Fort Worth							

Total vehicular traffic is displayed in [Table 16](#). The traffic level over the entire corridor is projected to grow significantly from 66,000 in 1998 to 99,000 in 2020, according to projections. The El Paso to Kent segment experiences the highest traffic levels; however,

capacity is more of a concern over the Kent to Dallas segment. The volume-to-capacity ratio for that segment was near capacity in 1998 and is expected to exceed capacity levels by 2010 and reach a ratio of 1.48 in 2020. The Interstate 10 segment will reach 1.00 in 2010 and will exceed capacity by 2020.

**Table 16. El Paso to Dallas Corridor Traffic Volumes and Capacity Levels.**

Corridor Segment	Segment Length	Average AADT			Average V/C Ratio		
		1998	2010	2020	1998	2010	2020
I10 EP-Kent	173.0	91,980	117,048	136,766	0.76	1.00	1.18
I20 Kent-FW	468.0	40,274	52,601	61,662	0.94	1.26	1.48
Total	641.1	66,127	84,825	99,214	0.85	1.13	1.33
AADT – Average annual daily traffic; V/C Ratio – Volume-to-Capacity Ratio; EP – El Paso; FW – Fort Worth							

The truck levels along the El Paso to Dallas corridor are expected to grow by 64 percent from the 1998 levels to 2020, as shown in Table 17. The Interstate 10 segment experiences higher overall truck levels, but the average FAF truck levels are projected to be higher along the Interstate 20 segment.

**Table 17. El Paso to Dallas Corridor Truck Volumes.**

Corridor Segment	Segment Length	Average AADTT			Average FAF		
		1998	2010	2020	1998	2010	2020
I10 EP-Kent	173.0	8,174	9,772	12,334	4,287	4,304	5,204
I20 Kent-FW	468.0	4,629	6,973	8,738	3,281	5,078	6,267
Total	641.1	6,402	8,372	10,536	3,784	4,691	5,735
AADTT – Average annual daily truck traffic = all trucking units; FAF – Freight Analysis Framework truck traffic = 60,000-80,000 lb. units only EP – El Paso; FW – Fort Worth							

According to the *Effect of NAFTA on the Texas Highway System* both Interstate 10 and Interstate 20 are significant passageways for NAFTA truck traffic. Interstate 10 carries 17.3 percent of all the NAFTA trucks and Interstate 20 carries 8.5 percent of all the NAFTA trucks (44).

### Rail Route Characteristics

The acquisition of the T&P line during the merger with Southern Pacific and the infrastructure improvements undertaken afterward have greatly improved UP's system

operations. The route from Los Angeles to Dallas is now 233 miles shorter than the former Southern Pacific route and 999 miles shorter than the former UP route (55). This improvement in system operations allows UP to battle for the vital long-haul traffic from the West Coast to Texas, Memphis, and the Eastern U.S. Figure 22 shows the pre- and post-merger UP and SP routes and also the competing BNSF routes.

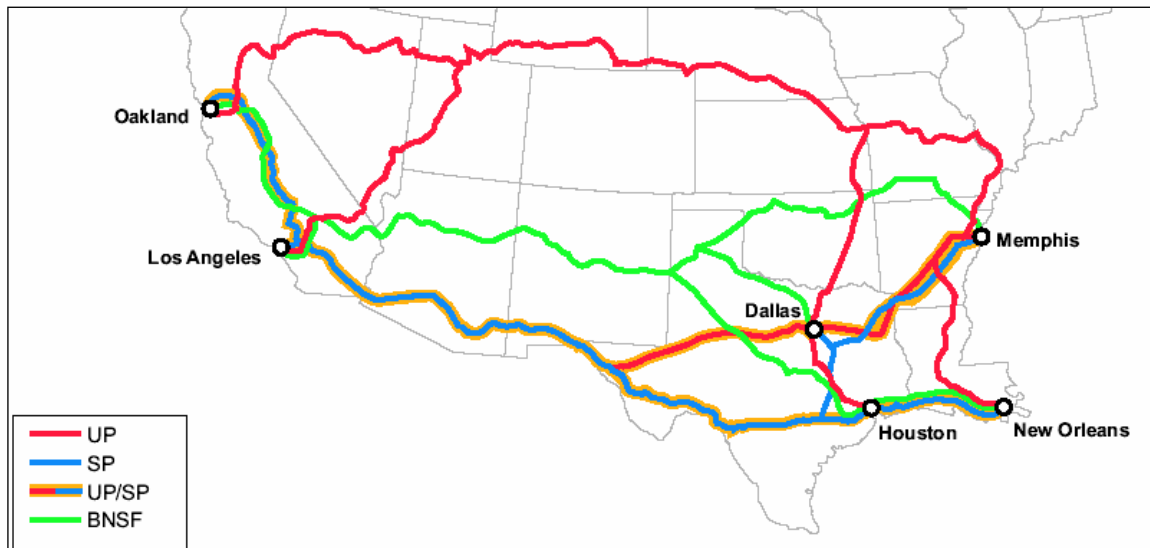

**Figure 22. West Coast – South Central-Southeast Route Efficiencies Gained from Union Pacific Merger with Southern Pacific (55).**

The Texas route closely parallels the highway from El Paso to Fort Worth: the Sunset Route along Interstate 10 from El Paso to Sierra Blanca and the T&P line along Interstate 20 from Sierra Blanca to Fort Worth. The entire rail segment from El Paso to Dallas is approximately 640 miles. There are intermodal facilities at both ends of the route. The El Paso yard primarily serves international traffic between Mexico and the U.S. and has a reported lift capacity of 96,000 lifts (56). Additional yard services are also available in El Paso at several UP yard locations. As previously stated, the Dallas-Fort Worth area intermodal facilities reside at Miller and Mesquite Yards.

Union Pacific identified this route as critical to their transcontinental operations of intermodal traffic from California to Memphis, where the shipments interchanged with one of the eastern railroads. Not only did the distance decrease to Dallas from California, but the entire route to Memphis is now 283 miles shorter compared to the former Southern Pacific route and 580 miles shorter compared to the former UP route (55). According to UP’s *Third Annual Report on Merger and Condition Implementation*, \$106.6 million of an estimated \$125.4 million

was spent on the T&P line between Fort Worth and El Paso to increase speed and capacity (57). These upgrades were necessary to implement the direct route from El Paso to Fort Worth via the T&P line versus moving traffic along the Sunset Route over to San Antonio and up to the Dallas-Fort Worth area.

In the August 2002 edition of *Trains Magazine*, an article described the T&P line from Fort Worth to El Paso (58). The vision of the line, as stated in the article, has always been to develop a highly competitive transcontinental route that will dominate both railroad and truck competition. In order to achieve this goal and to overcome the historic lack of maintenance and capital toward the line, UP has implemented several infrastructure and operational improvement strategies.

The three major infrastructure improvements focused on siding lengths and locations, signal systems, and track conditions. The major emphasis on sidings occurred over the 160-mile segment between Monahans and Sierra Blanca where UP installed six new sidings. The spacing between the existing sidings included 57 miles from Monahans to Toyah, 43 miles from Toyah to Boracho, and 60 miles from Boracho to Sierra Blanca, but the additional sidings reduced the average spacing between sidings to 20 miles (58).

Union Pacific also addressed improvements with the signaling. Current train control along the route consists of the following:

- Fort Worth to Clyde – Centralized Traffic Control;
- Clyde to Sierra Blanca – Automatic Block Signals dispatched by Track Warrant Control; and
- Sierra Blanca to El Paso – Centralized Traffic Control.

The stretch from Fort Worth to Clyde received CTC in 1957. To improve operations along the Clyde to Sierra Blanca segment, UP installed six new sidings with “CTC islands” west of Monahans (58). These islands, along with the siding at Toyah, provide some of the benefits of CTC operations along the route. The Sierra Blanca to El Paso stretch resides along the heavily used Sunset Route, which operates under CTC.

The *Trains* article indicates the rail line between Big Springs and Sierra Blanca was jointed and had been laid between 1942 and 1945. Recent infrastructure improvements, pre- and post- merger, included welded rail from Fort Worth to Abilene, from Iatan to Big Springs, from Sweetwater to Iatan, and between Abilene and Sweetwater. An additional 50-mile section on

both sides of Odessa received 136-pound welded rail (58). With these improvements, train speeds have increased along the route. Union Pacific news releases indicate new operating speeds of 60 mph through Abilene, Midland, and Odessa (59, 60, 61). Despite the infrastructure improvements over the T&P line, Frailey in the *Trains* article points out that 200 miles of aged, jointed rail still exists between Big Spring and Sierra Blanca (58).

Union Pacific now utilizes this route for both trailer and container intermodal services between the West Coast and Texas or Memphis. The Blue Streak intermodal trailer service consists of two offerings. One pertains to a service in alliance with Norfolk Southern that transports trailers between California and Atlanta, with the interchange occurring at Memphis. This service travels the Los Angeles to Memphis segment in approximately 57 hours, primarily serving United Parcel Service and Schneider National (58). The other Blue Streak service connects the Mesquite Yard to the East Los Angeles Yard for westbound movements and the East Los Angeles Yard to the Marion, Arkansas, intermodal facility, which sits across the Mississippi River from Memphis (58).

Double-stack container movements connect at Miller Yard in Dallas, at the Marion Yard, or with Norfolk Southern or CSX in Memphis, Tennessee. The double-stack flow of containers favors eastbound movements, creating the need to run empty railcars and empty boxes back to the West Coast.

Total train movements average 11 trains per day along the route, according to the *Trains* article (58). Density over that stretch in 2001 was between 20 and 39.9 MGTM/Mi (52).

### **El Paso to Dallas Enhanced Intermodal Option**

The Laredo to Dallas and Houston to Dallas routes consisted of direct inputs from the railroads for infrastructure costs and service levels. These details provide the necessary inputs for the economic evaluation in Chapter 6. An economic evaluation is not performed for this corridor. Provided the detailed information related to equipment costs, terminal and infrastructure costs, service levels, and shipping fees, this type of service could be evaluated utilizing the evaluation tool developed for this project. Although there are examples of such services around the world, the lack of detailed information specific to requirements of such a service in the U.S. necessitated the research team to examine this corridor qualitatively.

In examining the service for this corridor between El Paso and Dallas, the service consists of a land ferry intermodal service, in which the entire truck, including tractor, trailer, and driver, is transported via rail. In order to transport the driver along with the truck, the trains require business and sleeper cars. Recent efforts by the U.S. railroads to create truck-like transcontinental intermodal service has led to the examination of including business and sleeper cars for extra train crew members. One of these trains operated by UP was photographed in a recent *Trains Magazine* article, as shown in [Figure 23](#).



**Figure 23. Union Pacific’s High-Priority Transcontinental Train Including Business and Sleeper Cars (62).**

In addition to providing the driver accommodations for a land ferry service, there are several other considerations required for such a service.

- **Service Levels** – The service must provide highway-competitive transit times and truck-like reliability. In order to perform at high levels, the service requires dedicated terminals and dedicated, specialized rail equipment.
- **Customer Base** – The most critical consideration for this service is for whom the service is geared. In a service transporting the truck equipment along with the driver, the most likely scenario is the service targets a component of the total trip.

For this particular route, this includes traffic from the West Coast ports traveling across the country to market centers in the interior, such as Dallas, Memphis, and markets along the East Coast, such as Atlanta. Also of particular interest is international traffic to and from El Paso that passes through Dallas headed to the Midwest or East Coast.

- **Highway and Truck Volumes** – The El Paso to Dallas corridor is projected to experience an average of over 10,500 total trucks by 2020 and a volume-to-capacity ratio of 1.33. With continued traffic growth along the corridor likely resulting in reduced traveling performance, the corridor provides opportunities to transfer vehicles to the intermodal service.
- **Terminal Locations and Operations** – The terminals on both ends must provide easy access and operate effectively in order for drivers to consider the service. The high service level requirements greatly depend on the operations within the terminals, which act as the first and last components of the service.
- **Driver and Trucking Company Benefits** – Drivers and trucking companies require the service benefit them in a tangible manner. A land ferry service provides an opportunity for the drivers to meet their “off duty” rest requirements while the shipment remains in motion toward the final destination. Financially, this service reduces the fuel requirements for the 640-mile journey and maintenance costs, although only slightly.
- **Service Fees** – The fees need to be minimal or there will be no business. However, for the service to be self-sufficient it will require enough revenue for the railroads to cover the significant operational costs and desired profits. The most likely scenario is a land ferry service would require significant public intervention, perhaps in terms of a subsidy, in order for the service to be financially feasible, for both the railroads and the trucking entity.
- **Railroad Operations** – This service requires dedicated terminals and equipment, both of which add significant financial burdens on the railroads for operations. They also require significant up-front investments, which could be shared with the public sector.

Table 18 provides an overview of the El Paso to Dallas intermodal service described above.

**Table 18. El Paso to Dallas Corridor Intermodal Service.**

<b>Service</b>
<ul style="list-style-type: none"> <li>• Dedicated land ferry service between El Paso and Dallas – tractor, trailer, and driver</li> <li>• Business and sleeper cars for truck drivers</li> <li>• Highway-competitive transit times – approximately 10 hours</li> </ul>
<b>Target</b>
<ul style="list-style-type: none"> <li>• Trucks traveling completely through Texas along Interstate 20</li> <li>• International movements to/from El Paso that travel along Interstate 20</li> <li>• Trucks traveling, at minimum, between El Paso and Dallas</li> </ul>
<b>Cost Considerations</b>
<ul style="list-style-type: none"> <li>• Facility costs – dedicated terminals at both ends</li> <li>• Dedicated, highly-specialized rail equipment</li> <li>• Infrastructure improvements along route</li> </ul>



## **CHAPTER 6: ECONOMIC ANALYSIS OF INTERMODAL RAIL**

The justification for pursuing public-private intermodal ventures within existing rail corridors should be structured upon the realization of favorable economic returns for each participating entity. In the case of public entities, economic feasibility is usually based on a cost-benefit analysis such as net present value or benefit/cost ratio; on the other hand, the private sector usually selects projects for investment based on a monetary rate of return (63). The passage of House Bill 3588 (HB 3588) created a new obligation for Texas transportation officials to examine the economic feasibility of joint ventures, such as those considered in this research, no longer only in terms of those they represent but also from the perspective of their financial partners. As a result, both cost-benefit analyses and corporate rates of return were considered in the preparation of this project.

The following sections present the basic theory and economic evaluation framework upon which this approach is constructed. However, it should be noted that the results presented herein are intended only to demonstrate the recommended methodology for evaluating the economics of these projects, and not to actually recommend the implementation or rejection of funding for the examples shown. This work does, however, show a way to determine two-party feasibility and suggests that more extensive development and refinement of the basic economic model would be of value.

### **ECONOMIC ANALYSIS FUNDAMENTALS**

The Office of Management and Budget recommends the use of cost-benefit analysis in the evaluation of government projects, whereby net benefits to “society” are the basis for evaluation (64). While the determination of net societal benefits is part of this analysis, this research also evaluates net benefits specific to the Texas Department of Transportation in terms of preserving transportation infrastructure. Of course, performing such an analysis requires the subjective selection of cost and benefit data that most certainly will be subject to scrutiny, particularly when both public and private partners contribute to project funding. Therefore, a method of analysis for this intermodal study was developed to promote an understanding of each party’s financial constraints and decision-making processes so that a mutually beneficial project funding strategy can be devised.

## **Need for an Economic Model**

Project evaluation of public-private partnerships should incorporate a consensus-building tool that provides transparency in identifying costs and in determining benefits that may be realized by each party. For example, a public entity would most likely choose not to partly finance rail infrastructure improvements that resulted in exorbitant profits for the railroad. On the other hand, a railroad may choose not to finance capital improvements foreseen as marginally profitable even if such expenditures would postpone or eliminate the need to construct public infrastructure. In the first of these cases, overstating costs by the private sector could hide the potential for large profits in order to attract public funding; in the second, understating the true public benefits of investing in a rail project could result in a missed opportunity to engage the help of the private sector. Consequently, this consensus-building tool must not only predict value to public and private partners with reasonable accuracy, it must also provide transparency in stated costs and avoided costs (i.e., benefits).

### ***The Economic Model***

Decisions made by the state concerning public-private partnerships will likely be subject to greater scrutiny than prior to HB 3588, and it is for this reason that the elementary proof-of-concept economic model shown in [Figure 24](#) was prepared. Essentially, this model is a framework for the state to clarify relationships with railroads and describe the effects of assumptions on costs, benefits, financial requirements, and operating conditions (65). Kenneth Small describes the best method of disclosure as “one that makes it possible to understand and justify political decisions that are in the interests of the citizenry at large, while embarrassing those who would make decisions favoring only narrow interest groups,” and this model should be a reasonable first step toward that goal (65).

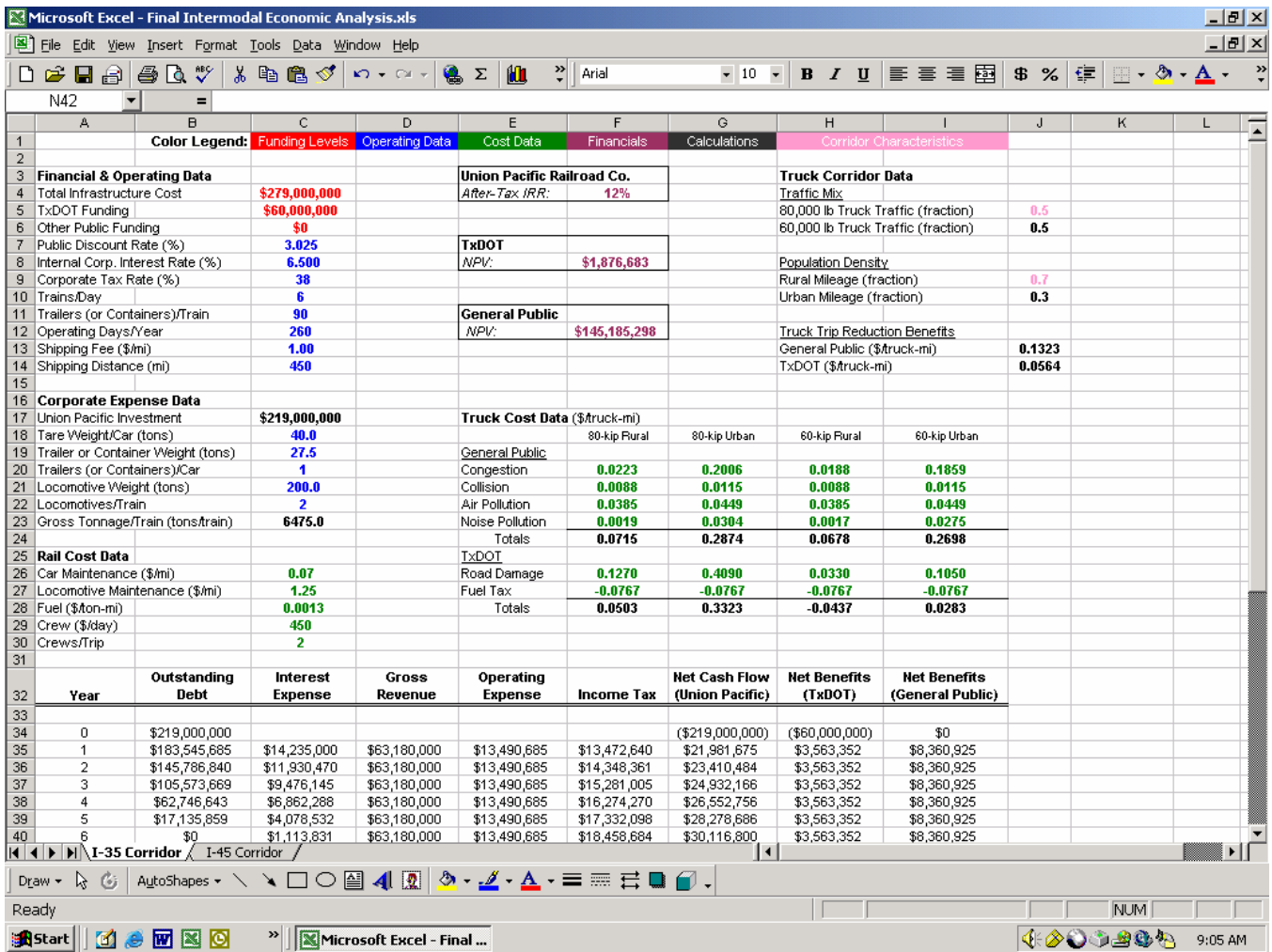

Figure 24. Spreadsheet Model for the Economic Analysis of Intermodal Rail.

### Model Inputs

The spreadsheet model shown in Figure 24 has been color-coded to differentiate between types of input data. Each input category has been classified according to the frequency at which the information will likely change. For example, a large number of trial inputs for public funding is expected as part of an economic analysis, so this category is color-coded red, whereas unit costs associated with rail or truck transportation are expected to change infrequently, so these items are color-coded green. Each of the following input data are included in the model:

- Funding levels – total project cost and levels of public financing
- Operating data – data associated with railroad operations as follows:
  1. Rail corridor operations
    - discount rate (for public investments)
    - internal corporate interest rate (for project financing)

- corporate tax rate
- trains per day
- truck trailers or containers per train
- operating days per year
- shipping fee
- shipping distance (corridor length)
- 2. Train operating conditions
  - railcar tare weight
  - truck trailer or container weight
  - number of trailers or containers per railcar
  - locomotive weight
  - locomotives per train
- Cost data – operating costs associated with the movement of freight as follows:
  1. Rail transportation
    - railcar maintenance cost per mile
    - locomotive maintenance cost per mile
    - fuel cost per ton-mile
    - train crew costs (two personnel per locomotive)
    - number of train crews per corridor trip (based on 8-hour work day)
  2. Truck transportation
    - societal costs (roadway congestion, automobile collisions, and pollution)
    - infrastructure costs (roadway damage minus fuel tax revenue)
- Corridor Characteristics – traffic mix and population densities along corridor

Even though railroad unit operating costs have remained consistent throughout recent time, these values were confirmed by recent literature (66). Also, truck unit operating costs from the 1997 Federal Cost Allocation Study and 2000 addendum were used to calculate social and infrastructure cost reductions – that is, benefits of diverting trucks to rail – in the economic model (67, 16). These parameters are defined below:

- pavement cost – cost of repairing pavement deterioration;
- congestion cost – value of additional travel time due to small increments of traffic;

- collision cost – medical costs, property damage, lost productivity, and pain and suffering associated with highway crashes;
- air pollution cost – cost of premature death and illness due to vehicular emissions; and
- noise pollution cost – change in value of adjacent properties caused by motor-related noise.

Of these parameters, the economic model includes separate computations of public well being for 1) TxDOT, where only reductions in pavement damage are considered, and 2) general society, where all other avoided costs are considered. Also, reducing truck trips will impose a cost to TxDOT in the form of lost fuel tax revenue; namely, the \$0.20 per gallon state tax and the state's 87.4 percent share of the \$0.21 per gallon federal tax. Therefore, assuming an average truck fuel efficiency of 5 miles per gallon, a cost to TxDOT of  $[\$0.20/\text{gal} + 0.874(\$0.21/\text{gal})] / 5 \text{ miles/gal} = \$0.0767/\text{mile}$  is included in the TxDOT computations.

As shown in [Figure 24](#), the FHWA has established separate marginal costs for 60,000-pound and 80,000-pound trucks traveling through both rural and urban areas – distinctions were made between these areas using a threshold of 50,000 persons as defined by the Bureau of Transportation Statistics (68). The traffic mix factors, which can be adjusted as “corridor characteristics” features, take into account these differences in marginal costs for rural and urban areas.

The FHWA has also prepared a report on trucking industry costs titled Expenses Per Mile for the Motor Carrier Industry (4). This reports that motor carrier expenses have ranged from \$1.34 to \$1.51 per mile during the last decade, subject to fluctuations in the price of diesel fuel, and are expected to increase by \$0.05 - \$0.06 by 2005. Consequently, any shipping fee charged by a railroad to transport trucks through an intermodal corridor will need to set rates well below this cost in order to entice the trucking industry to use rail service – for this study, researchers assumed a shipping fee of \$1.00 per truck-mile.

**Input Uncertainty and Risk.** Perhaps most important among cost and benefit issues is the degree of certainty with which these parameters are used in the economic model. New rail trackage is, for practical purposes, an irreversible capital expenditure that will obligate funds to untested intermodal projects, so an understanding of the variability in expected capital and

operating expenses is needed (65). Flyvbjerg *et al.* noted that among all public transportation projects, rail projects incur the highest difference between the actual cost and the cost estimate that led to the decision to build (69). Even though intercity rail projects were only a portion of this data and while upgrades to existing freight rail corridors are arguably of lower risk, the uncertainty of cost data in the economic model should be recognized.

In terms of benefits, the ability to divert trucks from the roadway to the intermodal corridor is, at this point, speculative. Moreover, the greatest risk to achieving the expected benefits from an intermodal project may lie within planning decisions made by TxDOT with regard to the Trans Texas Corridor. For example, Figure 25 diagrams a scenario where there is a 50 percent probability that a portion of the Trans Texas Corridor, expected to contain rail infrastructure, is built near a candidate intermodal corridor. Furthermore, the scenario assumes there is a 50 percent probability that the candidate intermodal track itself would become the rail portion of the Trans Texas Corridor. Based on these assumptions, Figure 25 shows that there is a 75 percent probability of no competing rail infrastructure and, therefore, a 75 percent chance of project success since the benefits associated with revenues and truck diversions will be as expected – of course, there will also be uncertainty in the benefit parameters themselves, so the means of projecting revenues and truck diversions should be done with great care.

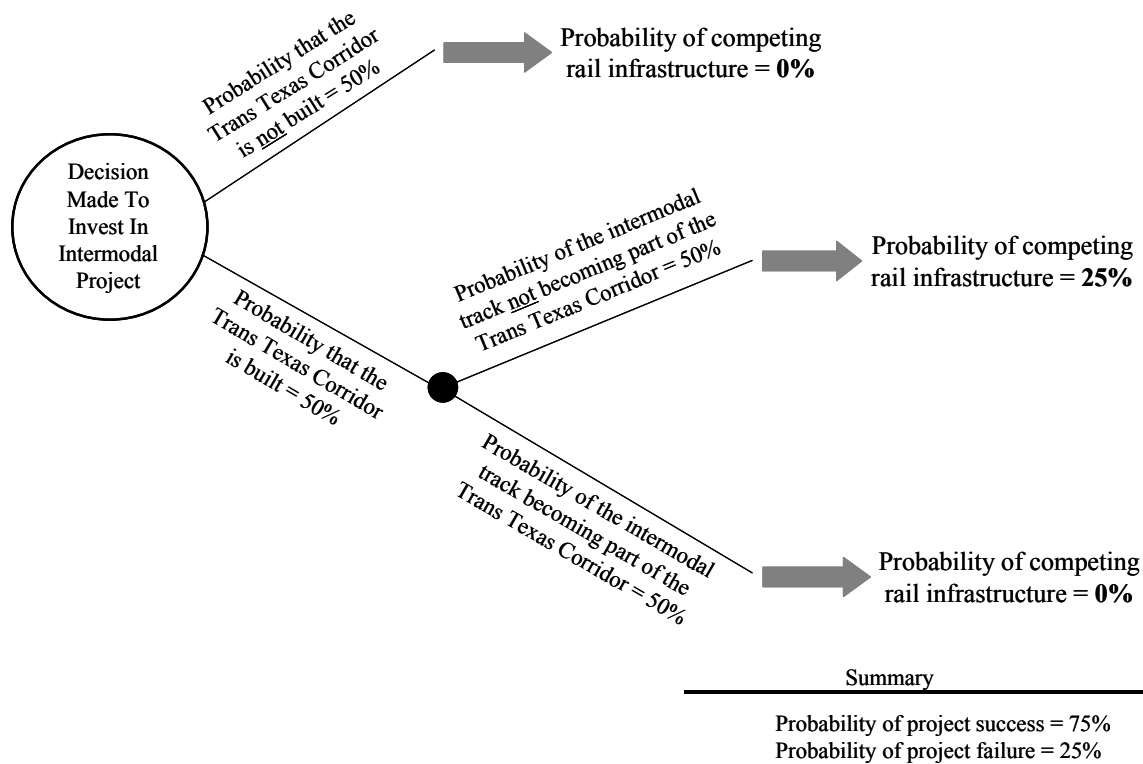

**Figure 25. Example of Intermodal Rail Project Success with Regard to Planning for the Trans Texas Corridor.**

**Model Outputs**

The outputs, or “financials,” for the spreadsheet model shown in Figure 24 are computations of net present value (NPV), which is a method of cost-benefit analysis that “discounts” a stream of projected annual costs and benefits to a present value of net benefits (70). This method can be expressed by the formula in Equation 1, showing that project costs are subtracted from project benefits in each of the years in which they are incurred and then discounted back to a present value. Since society places less value on benefits and costs that occur farther into the future, a discount rate,  $d$ , is selected that accounts for society’s willingness to trade off future benefits and costs (60).

$$NPV = \frac{B_0 - C_0}{(1+d)^0} + \frac{B_1 - C_1}{(1+d)^1} + \dots + \frac{B_t - C_t}{(1+d)^t} + \frac{B_n - C_n}{(1+d)^n}, \tag{Eq. 1}$$

where

- $NPV$  = net present value,
- $C_t$  = dollar value of costs incurred at time  $t$ ,

$B_t$  = dollar value of benefits incurred at time  $t$ ,  
 $d$  = discount rate, and  
 $n$  = life of the project in years.

The economic model in [Figure 24](#) calculates an internal rate of return (the discount rate at which the NPV is zero) to the investing railroad to determine how they may benefit from the proposed projects. Since a corporation's cost of capital represents an opportunity cost equal to the return that could have been earned on a similar alternative investment, the returns on an intermodal project must meet or exceed this rate. If the risk of investing in this project is foreseen as being greater than the risk of investing elsewhere, then the corporation will likely include a risk premium on the required rate of return (71). This risk premium may be largely subjective, based on management's perception of risk and knowledge of the transportation industry, and may be, say, only two percent for a low-risk investment but 20 percent for a high-risk investment. Most certainly, the railroad's perception of risk will consider the structure of the agreement between themselves and the public. Therefore, when using the model's calculated rate of return to judge whether a railroad might be willing to participate in a project, one must understand that this rate must at least equal the internal corporate interest rate and will likely exceed that amount.

The discount rate for public sector NPV calculations in this work was based on the 2003 real discount rates published by the Office of Management and Budget (OMB) in OMB Circular A-94: Guidelines and Discount Rates for Benefit-Cost Analysis of Federal Programs, as shown in [Table 19](#) (64). This document recommends that the analysis of projects with terms different than those shown in [Table 19](#) use linear interpolation to determine the appropriate interest rate. With the shortest service life of typical rail infrastructure components being approximately 25 years (i.e., signaling and communications), this research assumes a 25-year investment period and, correspondingly, a discount rate of 3.025 percent.

**Table 19. OMB Real Discount Rates for 2003.**

<b>Program Life (Years)</b>	<b>Discount Rate (Percent)</b>
3	1.6
5	1.9
7	2.2
10	2.5
30	3.2



**Output Uncertainty and Risk.** Just as with projects documented long ago by Krutilla and Eckstein, where waterway and irrigation projects were promoted by using unrealistically low discount rates, the intentional selection of an inappropriate rate can also introduce hidden bias into what might be an otherwise objective analysis of intermodal rail projects (72). Even more, a truly honest appraisal of the discount rate can be challenging. As explained by Small, the willingness to trade off future benefits and costs could easily be identified if a single stable market interest rate prevailed throughout the economy; however, differences in income taxes and the incompleteness of markets create a need for considerable judgment in setting rates (65). For this reason, the Office of Management and Budget provides uniformity in the use of discount rates for public investments by establishing those rates shown in Table 19.

Regardless of discount rate uniformity, project evaluations are still affected by the year in which the evaluations occur. Table 20 shows how dynamic economic conditions have changed OMB discount rates from 2002 to 2003 where rates have decreased by at least 0.5 percent. In consideration of this, the use of the economic model shown in Figure 24 should be accompanied by a sensitivity analysis to determine how changes in discount rates affect project feasibility (65).

**Table 20. Changes in OMB Real Discount Rates between 2002 and 2003.**

Program Life (Years)	2002 Discount Rate (Percent)	2003 Discount Rate (Percent)	Change (Percent)
3	2.1	1.6	-0.5
5	2.8	1.9	-0.9
7	3.0	2.2	-0.8
10	3.1	2.5	-0.6
30	3.9	3.2	-0.7

**Recommended Approach to Economic Modeling**

A close examination of Equation 1 reveals that small differences in the discount rate (e.g., Table 20) can have a significant impact on the economic analysis because net benefits in any given year are discounted by the factor  $1/(1+d)^t$ , which changes exponentially with time. As a result, projects evaluated over large time horizons will be susceptible to significant changes in outcome with small adjustments in the chosen discount rate. For example, if a project is anticipated to produce net benefits of \$11 million in the 30<sup>th</sup> year, then, according to Table 20, this value would be discounted by  $1/(1+0.039)^{30} = 0.3173$  if calculated using the 2002 rate and

by  $1/(1+0.032)^{30} = 0.3887$  if calculated using the 2003 rate. In other words, contributions to the NPV from net benefits received in the 30<sup>th</sup> year would differ by \$784,000, depending on which rate was used.

Considering the major uncertainties identified as being important in intermodal rail feasibility studies, such as anticipated costs and benefits, possible competition from the Trans Texas Corridor, and selecting a representative discount rate, it is recommended that the following guidelines proposed by Pickrell be followed when using the economic model (73):

- require peer review of evaluations,
- limit the time horizon that can be considered,
- require more detailed engineering support of cost estimates, and
- require specific types of sensitivity analysis.

## **RESULTS FOR SELECTED INTERMODAL CORRIDORS**

The economic analysis of short-haul intermodal freight in this research focuses on Union Pacific Railroad's Laredo to Dallas corridor and Burlington Northern Santa Fe Railway's Houston to Dallas corridor. Some general cost and operating data acquired from these companies for their respective corridors are as follows:

- UP's Laredo to Dallas Corridor
  - Project Cost = \$279 million
  - Corridor Length = 450 miles
  - Intermodal Service = 6 trains/day with 90 trailers/train
- BNSF's Houston to Dallas Corridor
  - Project Cost = \$100 million
  - Corridor Length = 228 miles
  - Intermodal Service = 4 trains/day with 85 trailers/train

Researchers used this information in conjunction with other general railroad operating data to perform separate economic analyses using the model shown in [Figure 24](#).

### ***Evaluation of the Laredo to Dallas Rail Corridor***

[Figure 26](#) shows sample input and output values for the economic feasibility of using Union Pacific's Laredo to Dallas rail corridor for intermodal freight operations. These particular

results are for the case where TxDOT breaks even on an investment of approximately \$62 million – that is, the state also receives \$62 million in reduced pavement damage (net of the fuel tax revenue loss). Union Pacific’s rate of return is shown to be 12.2 percent for this case, which is greater than the assumed internal corporate interest rate of 6.50 percent, indicating that this could be an attractive corporate investment to the railroad.

Color Legend:		Funding Levels	Operating Data	Cost Data	Financials	Calculations	Corridor Characteristics	
<b>Financial &amp; Operating Data</b>			<b>Union Pacific Railroad Co.</b>			<b>Truck Corridor Data</b>		
Total Infrastructure Cost	\$279,000,000		After-Tax IRR: 12.15%			Traffic Mix		
TxDOT Funding	\$61,876,600					80,000 lb Truck Traffic (fraction) 0.5		
Other Public Funding	\$0					60,000 lb Truck Traffic (fraction) 0.5		
Public Discount Rate (%)	3.025		<b>TxDOT</b>			Population Density		
Internal Corp. Interest Rate (%)	6.500		NPV: \$83			Rural Mileage (fraction) 0.7		
Corporate Tax Rate (%)	38					Urban Mileage (fraction) 0.3		
Trains/Day	6		<b>General Public</b>			Truck Trip Reduction Benefits		
Trailers (or Containers)/Train	90		NPV: \$145,185,298			General Public (\$/truck-mi) 0.1323		
Operating Days/Year	260					TxDOT (\$/truck-mi) 0.0564		
Shipping Fee (\$/mi)	1.00							
Shipping Distance (mi)	450							
<b>Corporate Expense Data</b>			<b>Truck Cost Data (\$/truck-mi)</b>					
Union Pacific Investment	\$217,123,400		80-kip Rural		80-kip Urban	60-kip Rural	60-kip Urban	
Tare Weight/Car (tons)	40.0		<b>General Public</b>					
Trailer or Container Weight (tons)	27.5		Congestion 0.0223 0.2006 0.0188 0.1859					
Trailers (or Containers)/Car	1		Collision 0.0088 0.0115 0.0088 0.0115					
Locomotive Weight (tons)	200.0		Air Pollution 0.0385 0.0449 0.0385 0.0449					
Locomotives/Train	2		Noise Pollution 0.0019 0.0304 0.0017 0.0275					
Gross Tonnage/Train (tons/train)	6475.0		Totals 0.0715 0.2874 0.0678 0.2698					
<b>Rail Cost Data</b>			<b>TxDOT</b>					
Car Maintenance (\$/mi)	0.07		Road Damage 0.1270 0.4090 0.0330 0.1050					
Locomotive Maintenance (\$/mi)	1.25		Fuel Tax -0.0767 -0.0767 -0.0767 -0.0767					
Fuel (\$/ton-mi)	0.0013		Totals 0.0503 0.3323 -0.0437 0.0283					
Crew (\$/day)	450							
Crews/Trip	2							
Year	Outstanding Debt	Interest Expense	Gross Revenue	Operating Expense	Income Tax	Net Cash Flow (Union Pacific)	Net Benefits (TxDOT)	Net Benefits (General Public)
0	\$217,123,400					(\$217,123,400)	(\$61,876,600)	\$0
1	\$181,547,106	\$14,113,021	\$63,180,000	\$13,490,685	\$13,518,992	\$22,057,302	\$3,563,352	\$8,360,925
2	\$143,658,353	\$11,800,562	\$63,180,000	\$13,490,685	\$14,397,726	\$23,491,027	\$3,563,352	\$8,360,925
3	\$103,306,831	\$9,337,793	\$63,180,000	\$13,490,685	\$15,333,578	\$25,017,944	\$3,563,352	\$8,360,925
4	\$60,332,460	\$6,714,944	\$63,180,000	\$13,490,685	\$16,330,261	\$26,644,110	\$3,563,352	\$8,360,925
5	\$14,564,755	\$3,921,610	\$63,180,000	\$13,490,685	\$17,391,728	\$28,375,977	\$3,563,352	\$8,360,925
6	\$0	\$946,709	\$63,180,000	\$13,490,685	\$18,522,190	\$30,220,416	\$3,563,352	\$8,360,925
7	\$0	\$0	\$63,180,000	\$13,490,685	\$18,881,940	\$30,807,375	\$3,563,352	\$8,360,925
8	\$0	\$0	\$63,180,000	\$13,490,685	\$18,881,940	\$30,807,375	\$3,563,352	\$8,360,925
9	\$0	\$0	\$63,180,000	\$13,490,685	\$18,881,940	\$30,807,375	\$3,563,352	\$8,360,925
10	\$0	\$0	\$63,180,000	\$13,490,685	\$18,881,940	\$30,807,375	\$3,563,352	\$8,360,925
11	\$0	\$0	\$63,180,000	\$13,490,685	\$18,881,940	\$30,807,375	\$3,563,352	\$8,360,925
12	\$0	\$0	\$63,180,000	\$13,490,685	\$18,881,940	\$30,807,375	\$3,563,352	\$8,360,925
13	\$0	\$0	\$63,180,000	\$13,490,685	\$18,881,940	\$30,807,375	\$3,563,352	\$8,360,925
14	\$0	\$0	\$63,180,000	\$13,490,685	\$18,881,940	\$30,807,375	\$3,563,352	\$8,360,925
15	\$0	\$0	\$63,180,000	\$13,490,685	\$18,881,940	\$30,807,375	\$3,563,352	\$8,360,925
16	\$0	\$0	\$63,180,000	\$13,490,685	\$18,881,940	\$30,807,375	\$3,563,352	\$8,360,925
17	\$0	\$0	\$63,180,000	\$13,490,685	\$18,881,940	\$30,807,375	\$3,563,352	\$8,360,925
18	\$0	\$0	\$63,180,000	\$13,490,685	\$18,881,940	\$30,807,375	\$3,563,352	\$8,360,925
19	\$0	\$0	\$63,180,000	\$13,490,685	\$18,881,940	\$30,807,375	\$3,563,352	\$8,360,925
20	\$0	\$0	\$63,180,000	\$13,490,685	\$18,881,940	\$30,807,375	\$3,563,352	\$8,360,925
21	\$0	\$0	\$63,180,000	\$13,490,685	\$18,881,940	\$30,807,375	\$3,563,352	\$8,360,925
22	\$0	\$0	\$63,180,000	\$13,490,685	\$18,881,940	\$30,807,375	\$3,563,352	\$8,360,925
23	\$0	\$0	\$63,180,000	\$13,490,685	\$18,881,940	\$30,807,375	\$3,563,352	\$8,360,925
24	\$0	\$0	\$63,180,000	\$13,490,685	\$18,881,940	\$30,807,375	\$3,563,352	\$8,360,925
25	\$0	\$0	\$63,180,000	\$13,490,685	\$18,881,940	\$30,807,375	\$3,563,352	\$8,360,925

Figure 26. Sample Input and Output Data for the Laredo to Dallas Rail Corridor.

Figure 27 shows a plot of economic results for TxDOT and Union Pacific over a range of TxDOT funding levels. In order to illustrate how such a plot can be used the region where TxDOT's NPV is positive and Union Pacific's Internal Rate of Return (IRR) is greater than 10 percent (an assumed requirement) has been bracketed. This region represents the range of public funding levels where a compromise may be reached – assuming that all input parameters and computational methods have been agreed upon following a proper audit.

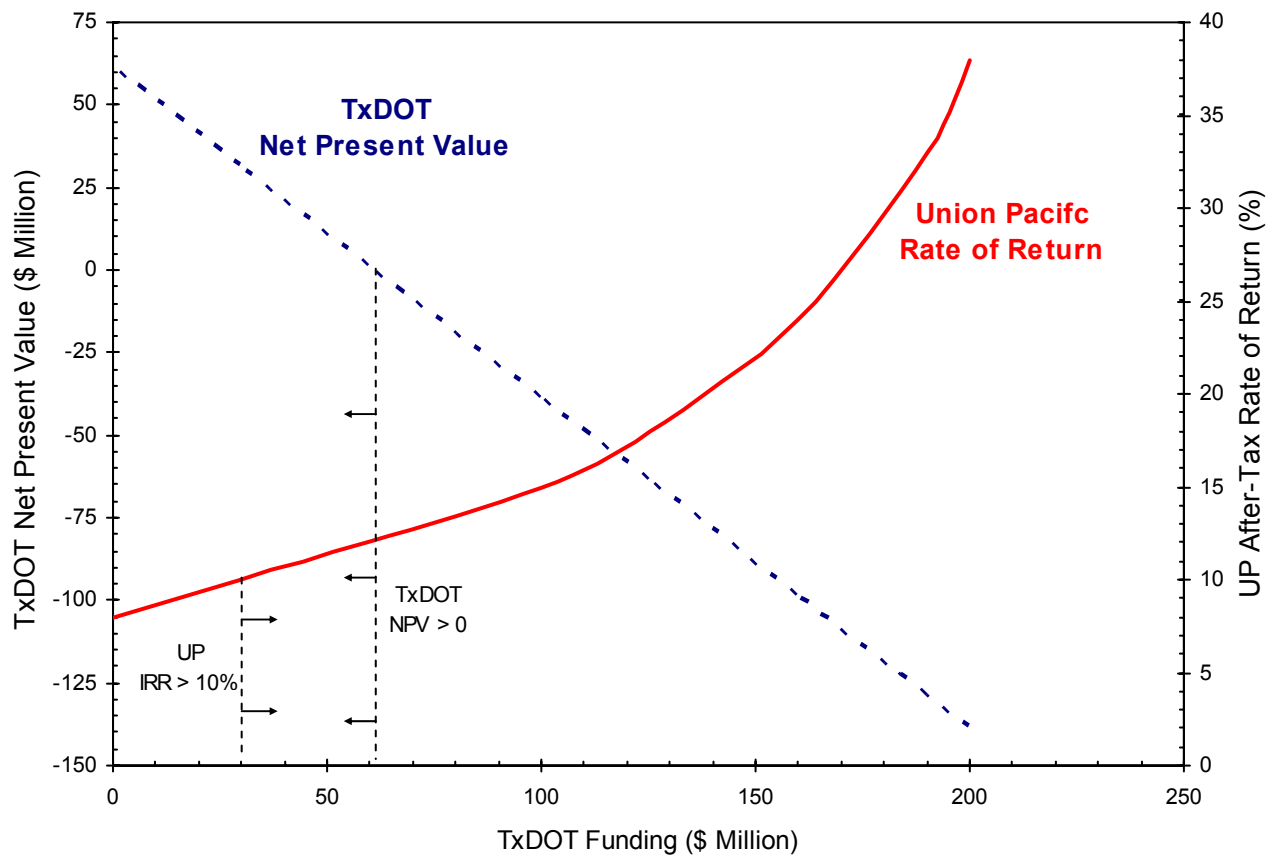

**Figure 27. Public and Private Economic Benefits for the Laredo to Dallas Corridor.**

***Evaluation of the Houston to Dallas Rail Corridor***

Figure 28 shows sample input and output values for the economic feasibility of using Burlington Northern Santa Fe's Houston to Dallas rail corridor for intermodal freight operations. Similar to the first analysis, these particular results are for the case where TxDOT breaks even on an investment of approximately \$20 million. As with UP's Laredo to Dallas corridor, BNSF's

rate of return of 9.3 percent is greater than the assumed internal corporate interest rate of 6.50 percent. This indicates that the economic feasibility of this intermodal corridor, while lower than that of the Laredo to Dallas corridor, is possible, but could be improved by initiating changes such as:

- Reducing capital or operating costs
- Securing funding from other public sources
- Increasing the numbers of trucks moved onto rail

The relatively short distance between Houston and Dallas could be a barrier to providing economically feasible intermodal service along this corridor – that is, if both TxDOT and BNSF are to gain from the partnership. BNSF’s 228-mile corridor is approximately one-half the length of UP’s 450-mile Laredo to Dallas corridor, which means that proportionally smaller amounts of railroad revenue and public benefits will accrue from each transported truck. Also, based on each railroad’s reported projections of intermodal service, BNSF would haul (4 trains/day) (85 trailers/train) = 340 trailers/day, whereas UP would haul (6 trains/day) (90 trailers/train) = 540 trailers/day; and this expected 228-trailer/day difference could limit the possibility of shared economic gains.

Color Legend:		Funding Levels	Operating Data	Cost Data	Financials	Calculations	Corridor Characteristics			
<b>Financial &amp; Operating Data</b>				<b>BNSF Railroad Co.</b>		<b>Truck Corridor Data</b>				
Total Infrastructure Cost	\$100,400,000			After-Tax IRR:	9.33%		Traffic Mix			
TxDOT Funding	\$19,739,400						80,000 lb Truck Traffic (fraction)			
Other Public Funding	\$0						60,000 lb Truck Traffic (fraction)			
Public Discount Rate (%)	3.025			TxDOT						
Internal Corp. Interest Rate (%)	6.500			NPV:	\$26		Population Density			
Corporate Tax Rate (%)	38						Rural Mileage (fraction)			
Trains/Day	4						Urban Mileage (fraction)			
Trailers (or Containers)/Train	85			<b>General Public</b>						
Operating Days/Year	260			NPV:	\$46,315,902		Truck Trip Reduction Benefits			
Shipping Fee (\$/mi)	1.00						General Public (\$/truck-mi)			
Shipping Distance (mi)	228						TxDOT (\$/truck-mi)			
<b>Corporate Expense Data</b>				<b>Truck Cost Data (\$/truck-mi)</b>						
BNSF Investment	\$80,660,600						80-kip Rural	80-kip Urban	60-kip Rural	60-kip Urban
Tare Weight/Car (tons)	40.0						<b>General Public</b>			
Trailer or Container Weight (tons)	27.5						Congestion			
Trailers (or Containers)/Car	1						0.0223	0.2006	0.0188	0.1859
Locomotive Weight (tons)	200.0						Collision			
Locomotives/Train	2						0.0088	0.0115	0.0088	0.0115
Gross Tonnage/Train (tons/train)	6137.5						Air Pollution			
							0.0385	0.0449	0.0385	0.0449
							Noise Pollution			
							0.0019	0.0304	0.0017	0.0275
							Totals			
							0.0715	0.2874	0.0678	0.2698
<b>Rail Cost Data</b>				<b>TxDOT</b>						
Car Maintenance (\$/mi)	0.07						Road Damage			
Locomotive Maintenance (\$/mi)	1.25						0.1270	0.4090	0.0330	0.1050
Fuel (\$/ton-mi)	0.0013						Fuel Tax			
Crew (\$/day)	450						-0.0767	-0.0767	-0.0767	-0.0767
Crews/Trip	2						Totals			
							0.0503	0.3323	0.0437	0.0283
<b>Year</b>	<b>Outstanding Debt</b>	<b>Interest Expense</b>	<b>Gross Revenue</b>	<b>Operating Expense</b>	<b>Income Tax</b>	<b>Net Cash Flow (Union Pacific)</b>	<b>Net Benefits (TxDOT)</b>	<b>Net Benefits (General Public)</b>		
0	\$80,660,600					(\$80,660,600)	(\$19,739,400)	\$0		
1	\$70,579,924	\$5,242,939	\$20,155,200	\$4,831,585	\$3,830,657	\$6,250,019	\$1,136,753	\$2,667,238		
2	\$59,844,004	\$4,587,695	\$20,155,200	\$4,831,585	\$4,079,649	\$6,656,270	\$1,136,753	\$2,667,238		
3	\$48,410,250	\$3,889,860	\$20,155,200	\$4,831,585	\$4,344,827	\$7,088,928	\$1,136,753	\$2,667,238		
4	\$36,233,301	\$3,146,666	\$20,155,200	\$4,831,585	\$4,627,240	\$7,549,708	\$1,136,753	\$2,667,238		
5	\$23,264,851	\$2,355,165	\$20,155,200	\$4,831,585	\$4,928,011	\$8,040,439	\$1,136,753	\$2,667,238		
6	\$9,453,452	\$1,512,215	\$20,155,200	\$4,831,585	\$5,248,332	\$8,563,068	\$1,136,753	\$2,667,238		
7	\$0	\$614,474	\$20,155,200	\$4,831,585	\$5,589,473	\$9,119,667	\$1,136,753	\$2,667,238		
8	\$0	\$0	\$20,155,200	\$4,831,585	\$5,822,974	\$9,500,641	\$1,136,753	\$2,667,238		
9	\$0	\$0	\$20,155,200	\$4,831,585	\$5,822,974	\$9,500,641	\$1,136,753	\$2,667,238		
10	\$0	\$0	\$20,155,200	\$4,831,585	\$5,822,974	\$9,500,641	\$1,136,753	\$2,667,238		
11	\$0	\$0	\$20,155,200	\$4,831,585	\$5,822,974	\$9,500,641	\$1,136,753	\$2,667,238		
12	\$0	\$0	\$20,155,200	\$4,831,585	\$5,822,974	\$9,500,641	\$1,136,753	\$2,667,238		
13	\$0	\$0	\$20,155,200	\$4,831,585	\$5,822,974	\$9,500,641	\$1,136,753	\$2,667,238		
14	\$0	\$0	\$20,155,200	\$4,831,585	\$5,822,974	\$9,500,641	\$1,136,753	\$2,667,238		
15	\$0	\$0	\$20,155,200	\$4,831,585	\$5,822,974	\$9,500,641	\$1,136,753	\$2,667,238		
16	\$0	\$0	\$20,155,200	\$4,831,585	\$5,822,974	\$9,500,641	\$1,136,753	\$2,667,238		
17	\$0	\$0	\$20,155,200	\$4,831,585	\$5,822,974	\$9,500,641	\$1,136,753	\$2,667,238		
18	\$0	\$0	\$20,155,200	\$4,831,585	\$5,822,974	\$9,500,641	\$1,136,753	\$2,667,238		
19	\$0	\$0	\$20,155,200	\$4,831,585	\$5,822,974	\$9,500,641	\$1,136,753	\$2,667,238		
20	\$0	\$0	\$20,155,200	\$4,831,585	\$5,822,974	\$9,500,641	\$1,136,753	\$2,667,238		
21	\$0	\$0	\$20,155,200	\$4,831,585	\$5,822,974	\$9,500,641	\$1,136,753	\$2,667,238		
22	\$0	\$0	\$20,155,200	\$4,831,585	\$5,822,974	\$9,500,641	\$1,136,753	\$2,667,238		
23	\$0	\$0	\$20,155,200	\$4,831,585	\$5,822,974	\$9,500,641	\$1,136,753	\$2,667,238		
24	\$0	\$0	\$20,155,200	\$4,831,585	\$5,822,974	\$9,500,641	\$1,136,753	\$2,667,238		
25	\$0	\$0	\$20,155,200	\$4,831,585	\$5,822,974	\$9,500,641	\$1,136,753	\$2,667,238		

Figure 28. Sample Input and Output Data for the Houston to Dallas Rail Corridor.

Figure 29 shows a plot of economic results for TxDOT and Burlington Northern Santa Fe over a range of TxDOT funding levels. Bracketing the boundaries for the example case where TxDOT's NPV is positive and BNSF's IRR is greater than 10 percent demonstrates the difficulty that would be encountered if the railroad requires a rate of return equal to or greater than this 10

percent. As a consequence, a more challenging approach to formulating an agreeable partnership would be required by the Houston to Dallas corridor than that for the Laredo to Dallas corridor.

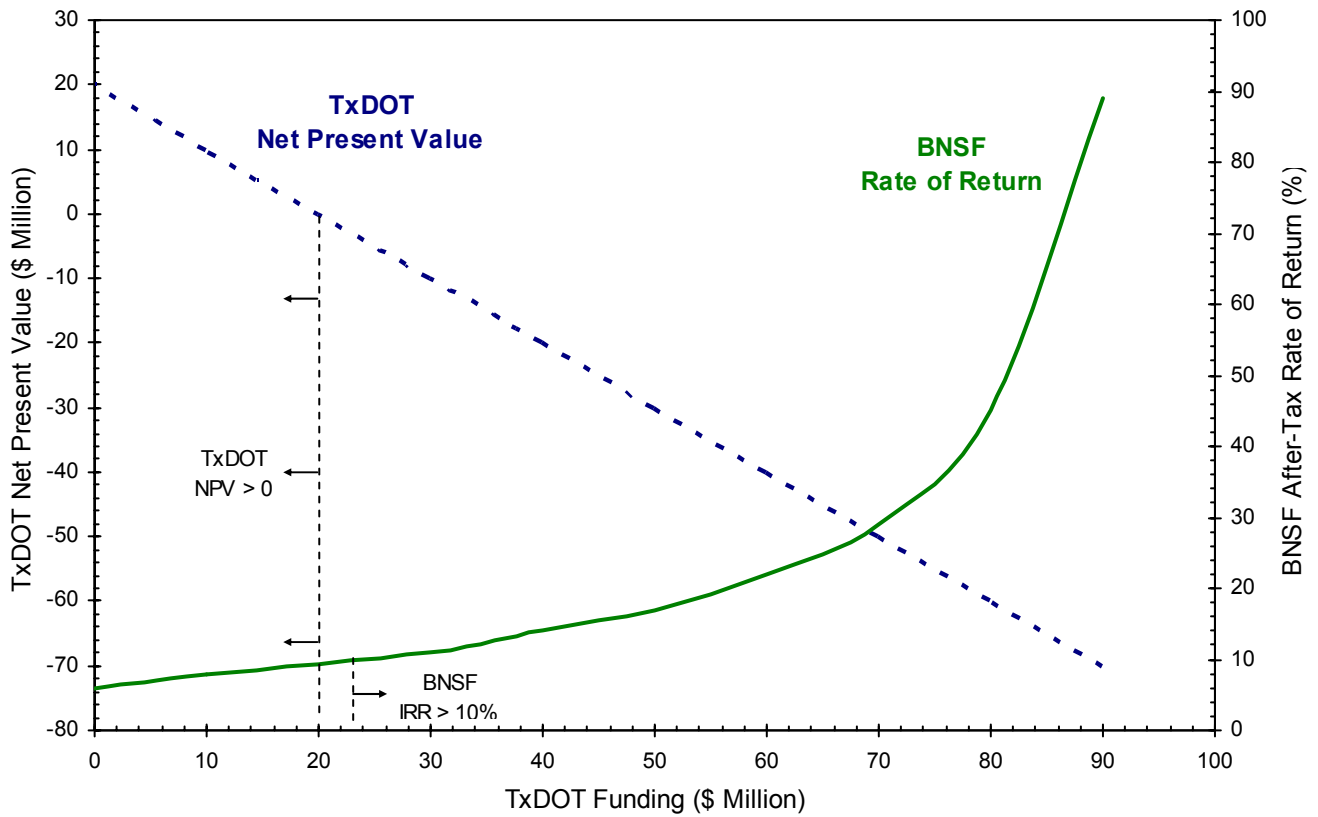

**Figure 29. Public and Private Economic Benefits for the Houston to Dallas Corridor.**





## **CHAPTER 7: FORMS OF PUBLIC-PRIVATE PARTNERSHIPS AND POTENTIAL APPLICATIONS IN TEXAS FOR ENHANCED INTERMODAL SERVICE**

Coupled with the growth in personal transportation demand, the increases in freight traffic as a result of the North American Free Trade Agreement and economic globalization are beginning to have increasingly detrimental impacts on Texas roadways. Public pressure grows for new or expanded facilities, while at the same time, the cost of maintaining the present system increases each year. Increased traffic is causing roadways to wear out at an accelerated rate while becoming more and more congested. State transportation officials have begun to realize that investing in highway improvements alone will not achieve the desired goals and have begun to seek private sector partnerships through which public transportation dollars may be leveraged to achieve the maximum benefits (74). The existing private rail network could be used to move much of the freight that is now traveling on Texas highways in a manner that could benefit both the public sector and private railroad companies that own the rail system.

Adding roadway capacity and constructing new toll roads are one way for the public sector to address demand for transportation infrastructure; however, the case for increased public reliance on intermodal transportation to assist in mitigating highway congestion is strong. For increased intermodal movements to take place, both the public sector and the private rail companies must seek out ways to capitalize upon one another's strengths. The remainder of this chapter will describe the possible forms that such a public-private partnership could take, describe the policy methods through which the state can assist rail companies, and potential financing methods for public-private partnerships (PPPs) before focusing on the specific makeup of potential PPPs in Texas based upon new state-level financing tools and political structures authorized by recent state transportation legislation.

### **HISTORY OF STATE-RAIL COMPANY PARTNERSHIPS IN TEXAS**

Over the last century we have become accustomed to the public sector being almost solely responsible for designing, financing, constructing, and maintaining transportation infrastructure—most notably, the highway system. This was not always the case. Rural cooperatives once built and maintained roadways using volunteer labor, private ferries once transported people and goods across rivers, and, during its early years as a state when Texas

needed to rapidly expand its transportation infrastructure and there was little capital to do so, state lawmakers turned to the private sector to take on the risks of constructing a rail transportation system. Consideration of PPPs between governmental entities and private rail transportation companies is today perceived as a new development, however; partnerships between the government and private railroad companies were, in fact, the catalyst for development of most of the rail transportation network in the state and triggered the economic development, settlement patterns, and population growth that followed. The lure of business profit, supported by attractive government policies, was used as a tool to bring about private investment that ultimately provided for the state's transportation needs.

As far back as the early 1850s, both local and state government encouraged private rail development through several means (although little progress was made during the American Civil War period during the early 1860s). Between 1850 and 1876, when the new state constitution prohibited local governments from doing so, various city and county governments in Texas passed bond proposals totaling approximately \$2.4 million for rail construction (75). At the state level, support took the form of both state financial loans and public land grants. Between 1854 and the outbreak of the American Civil War, six different railroad companies borrowed a total of \$1,816,500 from the young state's Special School Fund at \$6000 per mile of track to be constructed. The railroads repaid these loans to the state, with interest, in the amount of \$4,172,965, a 230 percent increase (75).

The state had limited capital funds to loan but it had millions of acres of public lands, so it also participated in land grants both before and after the war to stimulate building of new rail lines. The first state land grants began in the early 1850s, allowing for grants varying between eight and twenty sections of land for each mile of track constructed at different times during this period. Grants were stopped for a while by the Constitution of 1869 but began again following passage of the Constitution of 1876, which standardized railroad land grants at 16 sections per mile of track constructed. Under this constitutional provision, approximately 35,777,038 acres were granted to railroad companies, but faulty grants resulted in an actual public grant of 32,157,878 acres to railroad companies by the state (76). These grants were made during a 6 year period between 1876 and 1882, at which time the legislature repealed the land grant law after realizing that no unappropriated vacant public lands remained available in the state (75).

Thus, public land assets encouraged private investment and risk in order to develop a functioning statewide transportation system, which led to expansion and economic growth. This program was not without problems, as railroad companies took advantage of the advantageous policies and many private citizens objected to the magnitude of the lands being granted. In spite of the excesses and abuses that occurred under the land grant system, the transportation and economic development needs of the young state were met to the benefit of both the public and private sectors as a result of the investment of public assets and the power of the private profit motive.

Today, Texas faces a similar transportation challenge to the one it faced a century and a half ago. While the problem today is not the nonexistence of transportation infrastructure, the need to rapidly expand capacity of the existing transportation system during a time of limited public capital points to the need for the state to once again seek private sector partners. State transportation officials must look for ways to respond to the rapidly increasing population growth and increased demand for movement of people and goods through using existing transportation infrastructure more efficiently. Public investment in and use of existing private rail networks can potentially alleviate some of the freight burden currently overtaxing the roadway system and, at the same time, reduce maintenance costs of the publicly funded roadway network by diverting larger percentages of truck traffic to the rail mode.

It is the responsibility of public agencies and transportation planners to seek transportation options that represent the best use of public funds. In many cases, investing in enhanced intermodal infrastructure and services through capital grants or operating subsidies to railroads for specific services may be that investment. To preclude consideration of such methods for historical or institutional reasons is both unwise and inefficient. Both the public and private sectors could potentially benefit from shifting truck freight traffic to intermodal rail/truck moves, but determining how to formulate effective partnerships between government and private business to successfully carry this out remains a challenge.

## **DEFINING PARTNERSHIPS AND PPPS**

A partnership is an agreement that is formed between two or more parties to pool their resources and attain a common goal. Partnerships are formed when one party lacks specific skills, financial backing, or is not large enough to handle an entire project using only its own

assets or strengths. Partnerships can be formed between governments, private companies, public companies, or individuals in any combination. Partnerships formed between a government entity and any private entity are referred to as Public-Private Partnerships.

Partnerships, including PPPs, can take many forms, but the key attribute that differentiates them from other types of agreements is risk sharing between parties. In most types of contractual agreements, one party agrees to pay another party for services performed according to a service agreement and the contracting party pays the contractor for services rendered. In a partnership, the parties that enter into a contract share the risks inherent to the project. They contribute their resources to the project in exchange for a share of the reward but are also exposed to the potential losses. The result is that both parties have a vested interest in the success of the project and will work collaboratively to guarantee success. The exact terms of the partnership must be negotiated before the work of the partnership begins.

Parties that enter into a partnership are not limited to only providing capital investment. They can contribute in other ways, such as providing credit worthiness/reduction of project risk, political support, technical expertise, and specialized equipment or labor. Ideally, all parties in the partnership are actively involved and bring their strengths or talents to the table to offset the weaknesses of the other members. In essence, parties to the partnership contribute a certain amount of value to a project and expect to receive rewards in proportion to the value they have brought.

Partnerships are easiest to form when the parties involved share common expected results and measures of success in addition to their goals; however, this is usually not the case. Partnerships are most difficult to form when, despite a common goal, one party does not appreciate or give validity to another's goal. PPPs can be a highly contentious type of partnership for this very reason. While there is little inherent difference between this type of partnership and many other types of partnerships, there are significant cultural, philosophical, and operational differences between public and private entities. These differences are significant enough that they create very unique conditions that can result in failure if these differences are not carefully managed and controlled. In order to understand these differences, knowledge of the various forms that PPPs can take is necessary.

## VARIOUS FORMS OF PPPS

In the book *Privatization and Public-Private Partnerships*, E. S. Savas outlines 11 different forms that PPPs can take in relation to the provision of infrastructure (77). These range from full public ownership to full private ownership of the facility. In between these two extremes, various responsibilities and ownership may be shared as shown in Figure 30. As can be seen, many potential forms for PPPs exist. Examples of several of these can be evidenced in recent TxDOT projects throughout the state.

### Infrastructure Public-Private Partnership Spectrum

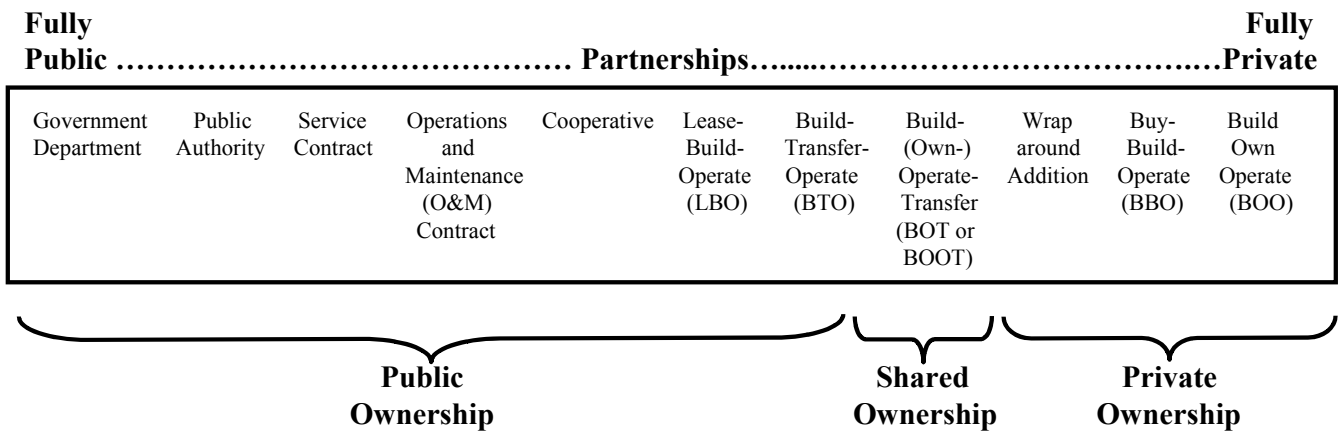

**Figure 30. Spectrum of Infrastructure Public-Private Partnerships (77).**

Savas’ eleven forms of PPPs are briefly outlined below:

- **Government Department:** A government agency owns, designs, finances, builds, and operates the facility.
- **Public Authority:** A separate government entity is set up to operate more like a business to oversee the construction and/or operation of the facility.
- **Service Contract:** A public agency retains responsibility for ownership and maintenance of the facility, but contracts out, for a defined period of time, certain aspects of the operation to a private firm, which is responsible for fulfilling its functions in order to receive contract payment.

- **Operations and Maintenance (O&M) Contract or Lease:** A private firm operates and maintains a publicly owned facility through a maintenance contract that holds the private firm responsible for the facility's proper operation.
- **Cooperative:** A non-profit, voluntary, cooperative association takes responsibility, often in a rural area, where government departments or authorities are not succeeding in providing needed or desired services.
- **Lease-Build-Operate (LBO):** A publicly owned facility is leased to a private firm which makes improvements at its own expense and recoups its investment from increased operations/activity over the term of the lease.
- **Build-Transfer-Operate (BTO):** A private firm finances and builds a facility, transfers ownership to the government once completed, then leases back the facility in order to operate it and recoup its initial investment plus a reasonable return during the term of the lease.
- **Build-Operate-Transfer (BOT) or Build-Own-Operate-Transfer (BOOT):** A private firm is awarded a franchise or concession to construct, operate, and charge and collect user fees for a facility for a defined period of time before transferring ownership of the facility to the public sector.
- **Wraparound Addition:** A private firm constructs and owns an addition to an existing public facility that the public cannot afford to improve at the present time and then operates and collects user fees on the combined facility for a defined period of time or until costs plus a reasonable return are recovered.
- **Buy-Build-Operate:** A private firm buys an existing public facility and then improves or expands it and operates it under a permanent franchise agreement.
- **Build-Own-Operate:** A private firm finances, constructs, owns, and operates a facility subject to government regulatory controls on pricing and operations under a long-term agreement that gives the private firm an incentive to invest its own funds in the project (77).

Before seeking private partners, public agencies such as TxDOT must select and/or modify a form of PPP that is acceptable to the state, yet attractive to private rail firms for creating enhanced intermodal services. In doing so, the department must be sure to safeguard the public's investment while at the same time accounting for the private railroad's desire to earn a

reasonable profit. Several tools that expand the types of PPPs available to TxDOT in making its selection have been recently passed by the 78<sup>th</sup> Legislature. These will be discussed further in the section on [Texas applications of PPPs](#) later in this chapter.

## COMPREHENSIVE RAIL POLICY CONSIDERATIONS

Development of a cooperative atmosphere at the policy level is an important precursor to direct involvement in a PPP between public agencies and the railroad companies. This helps to build a framework of common interests among the parties so that conflicts can be more easily resolved as the project or projects grow in complexity over time. Thus, in addition to understanding the full range of PPP possibilities that are available, there should be a comprehensive rail policy framework in place that will help the public agency to preserve, encourage, and participate in rail transportation projects that are of benefit to the citizens of the state.

During the literature review for this project, researchers reviewed several compilations of methods through which public sector agencies can assist private rail firms. As stated previously in this chapter, the idea of public sector cooperation with and assistance to rail companies is not new. A 1975 Council of State Governments study, *The States and Rural Rail Preservation: Alternative Strategies*, was one of the early documents that explored the role states could play in preserving rail infrastructure (78). While the federal regulatory framework under which these recommendations were made has changed considerably, many of the actions that the documents suggested as ways for state government to assist private rail companies to continue operations remain relevant.

During the 1970s, states were searching for the proper role that they could play under the new provisions put into place to deal with the rail crisis in the northeastern part of the U.S. The study made 19 recommendations to state governments as alternatives available to them in preserving rural rail service (78). These recommendations fall into four main areas—planning and legislative, system preservation, funding, and economic development measures as shown in [Table 21](#).

**Table 21. 1975 Recommendations to State Governments to Preserve Rural Rail (78).**

Area	Recommendation
Planning/ Legislative	<ul style="list-style-type: none"> <li>• States should develop a coordinated transportation policy and plan through a centralized agency.</li> <li>• States should review their existing rail statutes and repeal or modernize antiquated or obsolete sections.</li> <li>• States should review their existing crew laws for railroads and modify them where merited.</li> <li>• Contractual agreements between states, shippers, and railroads for rail service should have explicit clauses guaranteeing acceptable levels of performance.</li> <li>• States should require that railroads operating within the state annually submit their long-range plans for trackage abandonment and service curtailment.</li> <li>• In the interest of safety and economy, states should reduce the number of railroad grade crossings and bear a larger portion of their maintenance and construction costs.</li> </ul>
System Preservation	<ul style="list-style-type: none"> <li>• States should take an active role in rail abandonment proceedings which affect them.</li> <li>• States should preserve vital rail links to areas with natural and economic resources which have the potential for future expansion or development.</li> <li>• States should require that railroads submit annual operating summaries of each line which they operate within the state to justify possible financial assistance.</li> <li>• Creation of short line railroads with state assistance should be considered only under special circumstances.</li> <li>• Consideration should be given to state acquisition and subsequent leasing to an operator as a method of preserving rail service.</li> <li>• Following federal approval to abandon any rail right-of-way, the state must have the <i>first</i> opportunity to acquire the track and property.</li> </ul>
Funding	<ul style="list-style-type: none"> <li>• States should consider subsidizing short-term losses incurred on light-density branch lines.</li> <li>• State financial participation should be a part of any federal branch line subsidy program.</li> <li>• Under any state subsidy program, if a branch line being subsidized is found to be profitable; those profits should be used to offset other losses of that carrier's lines within the program.</li> <li>• States should review, reform, and equalize their railroad taxation practices.</li> <li>• States, in cooperation with local areas, should reduce property taxes where necessary to preserve and maintain rail service.</li> <li>• States should discourage the use of rail rate surcharges and arbitraries as a method of subsidizing rail service.</li> </ul>
Economic Development	<ul style="list-style-type: none"> <li>• State and railroad industrial development programs should cooperate in locating new industry on economically marginal branch lines.</li> </ul>

Individual states adopted several of these recommendations; however, there was no uniformity in adopting these policy recommendations from one state to another. Other proposals from the study were incorporated into federal legislation. The federal government created the requirement that each state develop a state rail plan in the late 1970s and funded state efforts to



do so until the mid-1980s. Also, during this time, the federal Local Rail Freight Assistance Act was in place, which gave limited funds to aid in rail preservation to each state. The Texas Railroad Commission was designated by the governor at that time to administer Texas' efforts in this area since a multimodal TxDOT did not yet exist (TxDOT's predecessor agency was the Texas Highway Department).

When federal funding for state-level rail planning stopped during the mid-1980s, the legislature did not appropriate state funding to continue active rail transportation planning at the state level or to create a state-level rail funding program. As a result, Texas has not had a recent history of directly participating in public-private partnerships with railroad companies or funding rail projects at the state level with the exception of a few individual projects that have been funded as riders on state appropriations bills. No systematic rail infrastructure program or funding source has been in place for use by state transportation planners to fill this need. In recent years TxDOT has begun to include the rail mode in its statewide, overall transportation planning, but it was not until 2003 that TxDOT was given authority by the 78<sup>th</sup> Legislature to build or manage rail infrastructure (79). While some of the recommendations in [Table 21](#) have been adopted or implemented in the state, many of these measures remain available as options for either TxDOT or the Texas legislature to encourage rail transportation use and development in the future. Additionally, TxDOT now has the authority to explore a number of funding scenarios for rail-oriented PPPs in order to leverage the funds that it now has at its disposal for rail projects.

### **Possible State-Rail Public-Private Partnership Strategies**

Following the passage of ISTEA in 1991 and its reauthorization through TEA-21 in 1998, several methods have emerged through which state transportation agencies can enter into PPPs with private rail firms to fund rail projects. Several of these strategies, along with the pros and cons of each are listed in the 2003 American Association of State Highway and Transportation Officials (AASHTO) Standing Committee on Rail Transportation (SCORT) Freight Rail Bottom Line Report, which was prepared to guide congressional deliberations regarding the reauthorization of TEA-21 for the FY 2004-FY 2009 period. This list, shown in [Table 22](#), outlines 14 financing methods through which freight rail-oriented PPPs could potentially

participate in intermodal projects. While this list is not exhaustive, it provides a good cross-section of the types of PPP strategies that are available.

**Table 22. AASHTO SCORT Freight Rail PPP Funding Strategies (12).**

<b>Direct Funding out of Railroad Revenues</b>
<b>Definition:</b> Railroad companies fund improvements out of their own profits for projects beneficial to the public and themselves.
<b>Pro:</b> Railroads can make investments where they generate sufficient revenue to repay the investment and serve profitable markets.
<b>Con:</b> Limited railroad investment funds; railroads are not earning their cost of capital, making borrowing on the open market more difficult and expensive; railroads cannot afford to invest in lower-profit lines and services; unlikely to invest in projects in order to achieve public benefits.
<b>Rail User Fees or Surcharges</b>
<b>Definition:</b> Public money is used to improve existing or build new rail infrastructure and then rail companies are charged user fees at a specified rate developed through a prior agreement (e.g., on a per car or per ton-mile basis) for use of the facilities.
<b>Pro:</b> User fees generate revenues to pay back construction bonds financed by the states or special-purpose authorities. The leading successful example is the recently opened Alameda Corridor.
<b>Con:</b> Requires stable and increasing volumes of traffic to generate revenue stream. The Alameda Corridor is a relatively unique situation. The corridor serves the high-volume container ports of Long Beach and Los Angeles; other locations may not have sufficiently stable and growing traffic to support user fees. Most manageable when applied to short, well-defined corridors or bridges and tunnels. More difficult to manage when multiple improvements must be made across a network and across a multistate region.
<b>Direct Federal Appropriations and Earmarks</b>
<b>Definition:</b> Federal funds are appropriated to a specific rail project, often for a specific use, through Congressional action.
<b>Pro:</b> Ensures targeted public investment in rail projects that have significant national, public benefits.
<b>Con:</b> Limited funds; requires lengthy public planning and review process; typically entails compliance with federal labor and other laws that are generally unacceptable to the railroads.

**Table 22. AASHTO SCORT Freight Rail PPP Funding Strategies (continued).**

<b>Congestion Mitigation and Air Quality (CMAQ) Program Grants</b>
<b>Definition:</b> CMAQ grants are authorized to EPA non-attainment areas for projects that improve air quality within that region.
<b>Pro:</b> CMAQ grants have been used to fund transportation improvements that reduce congestion and engine emissions in regions that do not meet national air quality standards.
<b>Con:</b> Lack of explicit eligibility for freight rail; limited funding.
<b>Transportation Infrastructure Finance and Innovation Act (TIFIA)</b>
<b>Definition:</b> U.S. DOT/federal loan program specifically for major transportation projects (total costs exceeding \$100 million).
<b>Pro:</b> Provides loans and loan guarantees for large transportation projects.
<b>Con:</b> Lack of explicit eligibility for freight-rail and intermodal projects; requires revenue stream to pay back loans; high threshold for project eligibility.
<b>Railroad Rehabilitation and Improvement Finance Program (RRIF)</b>
<b>Definition:</b> TEA-21 federal low-interest loan program administered by the Federal Railroad Administration that provides loans to both large and small railroad companies for capital improvements.
<b>Pro:</b> Loan program specifically for rail improvements; congressional proposals would significantly expand funding for the program.
<b>Con:</b> Limited funding at present; FRA lacks authorization to fund the mandated project credit risk analysis, so few projects have been initiated; funding focuses on investments with private, rather than public benefits; financially constrained railroads unlikely to invest in projects in order to achieve public benefits.
<b>Borders and Corridors</b>
<b>Definition:</b> Two, jointly administered, TEA-21 programs that are focused on meeting the transportation corridor needs along the U.S.-Canada and U.S.-Mexico borders and international transportation corridors.
<b>Pro:</b> Provides funds to states to plan and develop multistate trade corridors serving international trade gateways.
<b>Con:</b> Popular program but over-subscribed with limited funding, much of which has been earmarked to highway projects; rail projects are not explicitly eligible.
<b>Section 130 Grade Crossing Program</b>
<b>Definition:</b> Federal funding source, administered by states, for closing unnecessary highway/rail grade crossings or improving safety at highway/rail grade crossings by adding warning devices.
<b>Pro:</b> Provides for use of highway funds to eliminate dangerous highway/rail grade crossings or improve existing grade separations.
<b>Con:</b> Limited funding available; states and railroads are discussing expansion of the program but have not resolved concerns about assignment of liability for accidents at crossings.

**Table 22. AASHTO SCORT Freight Rail PPP Funding Strategies (continued).**

<b>Federal Tax-Credit Bond-Financing Programs</b>
<b>Definition:</b> Funding source under which the federal government would allow private rail companies to take tax credits in an amount proportional to funds that are spent on capital improvements to their rail infrastructure.
<b>Pro:</b> Tax credit financing might be used to generate funds for investment in rail infrastructure projects; funds could be distributed as grants, loans, or credit enhancements; could be targeted to specific types of businesses and improvements; does not impact discretionary portion of federal budget.
<b>Con:</b> New program not easily understood; numerous details to be worked out; impacts revenue side of the federal budget.
<b>Issuance of Tax-Exempt Debt for Railroad Infrastructure</b>
<b>Definition:</b> Federal government would allow private firms (railroad/non-railroad) to purchase tax-exempt debt instruments for funding rail infrastructure and other capital improvements.
<b>Pro:</b> Holders of debt would be exempt from tax on interest earned, resulting in reduced cost of funds; could be targeted to specific types of businesses and improvements; debt could be acquired by investors other than railroads; does not impact discretionary portion of federal budget.
<b>Con:</b> Will likely require congressional action to increase ceiling on state per-capita debt limit, and to allow tax-exempt debt for private activity; impacts the revenue side of the federal budget.
<b>Use of Rail Share of Gas Tax for Dedicated Railroad Trust Fund</b>
<b>Definition:</b> Current federal \$0.043 cent per gallon diesel-fuel tax paid by railroads would be devoted to rail use instead of going to the general fund.
<b>Pro:</b> Would reallocate \$0.043 cent per gallon diesel fuel tax paid currently by the railroads from the general fund to a dedicated railroad trust fund for rail infrastructure projects.
<b>Con:</b> Railroad industry opposes the tax; generates a modest amount of funding (\$160 million per year).
<b>State-Based Loans and Infrastructure Banks</b>
<b>Definition:</b> State-level funding programs would be created that could be given the flexibility to be used for rail infrastructure.
<b>Pro:</b> Would provide states with a mechanism to invest in rail improvements.
<b>Con:</b> States require seed money for banks and programs.

**Table 22. AASHTO SCORT Freight Rail PPP Funding Strategies (continued).**

<b>Sale of Freight Assets for Rail Passenger Use</b>
<b>Definition:</b> Conversion of existing freight rail facilities or rights-of-way to public for passenger rail purposes in exchange for direct financial payment or improvement to a rail company’s core rail facilities.
<b>Pro:</b> Generates cash, in-kind improvements, or state matching funds that states or railroads can use to invest in freight-rail service improvements.
<b>Con:</b> Limited opportunities; primarily in high-density metropolitan rail corridors; states must have sufficient transportation revenues to support purchase of assets or access rights.
<b>Relief from State Property Taxes on Rail</b>
<b>Definition:</b> State and local governments would reduce or eliminate property taxes on rail infrastructure in exchange for reinvestment of those monies into rail improvements.
<b>Pro:</b> State property taxes on rail were estimated at \$453 million in 1999; relief could be coupled with requirements that the funds be dedicated to rail improvements.
<b>Con:</b> Would represent a loss of state revenues that would have to be made up from other taxes or fees.

These examples of funding strategies show that there are many available options to financing PPPs between state government and a private railroad company; however, in addition to selecting a form and selecting the proper funding strategy, there are also political and legal barriers that must be overcome before a PPP can become a reality.

### **LEGAL AND POLITICAL OBSTACLES TO THE FORMATION OF PPPS**

One of the main reasons that PPPs have not been more prevalent in transportation projects is the variety of political and legal obstacles that both the public and private sectors face in forming a partnership. Studies performed to identify “challenges” or “barriers” to PPP formation have generally classified these into four areas—divergent motivation of the participants, limited resources, real or perceived legal/institutional barriers or unfair competition concerns among the partners, and evolving agendas at both the public and private institutions (80). Legal issues that should be evaluated and discussed during partnership formation include not only those between public and private, but also those that could potentially be problematic between two different public agencies that may be a part of the same partnership (81). The types of legal issues that should be addressed in forming a PPP include:

- differing statutory interpretations between partners (TEA-21, Clean Air Act Amendments, NAFTA, etc.);
- jurisdictional disputes;
- conflict of laws at different levels of government/between locations;
- labor compliance (i.e., unionized labor regulations and rules);
- differing land acquisition and capital expenditure procedures;
- federal preemption issues;
- intellectual property rights ownership;
- liability concerns;
- access issues;
- civil rights act/environmental justice issues;
- bonding procedures;
- risk allocation; and
- First Amendment issues (81).

Each of these general issues must be considered along with any other legal issue that might be unique to the project that is being undertaken. For enhanced intermodal projects such as the ones examined in this report, the list might also be expanded to include items such as impacts on local noise ordinances, issues associated with truck traffic generation, and/or community legal interests.

In addition to legal matters, political barriers to partnership formation also exist. These can vary from determination of authority over the project between jurisdictions to lack of state or federal laws that allow certain partnerships to be formed. Many barriers that existed in Texas for the creation of rail-related PPPs when this project began now no longer exist. HB 3588, adopted during the regular session of the 78<sup>th</sup> Texas Legislature (and discussed in more detail below), put in place several key policies that will now allow TxDOT to work with railroad companies to improve the rail system of the state, however, several limitations remain. HB 3588 puts an upper limit of \$12.5 million in state and federal funds to be available for rail projects, but provides several caveats that do not fall under this limit such as federal grants or from bonding programs such as the Texas Mobility Fund. The state constitutional provision that all funds raised from highway sources (e.g., state and federal gasoline tax revenues) is restricted to highway use only remains in place. In the near term, due to the identified needs of the highway system of the state,

it is unlikely that this provision will be considered for change to allow for diversion of some of these monies to other modes such as rail. TxDOT has also interpreted HB 3588 to limit TxDOT's participation in rail projects only to those projects in which TxDOT or the state has an ownership interest (82). This interpretation will, in many ways, define or limit the types of partnerships that might be available for enhanced intermodal projects. Continued legislative and political actions will undoubtedly have a great influence on what types of PPPs will be possible in the state.

## **APPLICATION OF PPPS IN TEXAS**

Up to this point, the broad array of possible PPP forms and funding strategies have been described. This section of the report will describe how and if recent legislative measures passed in Texas will limit or expand the choices available within the state. In addition to the general conclusions concerning this topic, it will also make observations regarding the types of PPPs that might be applied to the enhanced intermodal scenarios examined in this project.

### **HB 3588 Provisions**

The 78<sup>th</sup> Texas Legislature passed an omnibus transportation bill, HB 3588, during its regular session in the spring of 2003. This bill drastically overhauled the way in which TxDOT approaches its responsibilities for providing and coordinating the use of transportation infrastructure in the state. Among the many provisions of this bill, several important measures related to rail infrastructure were included.

Passage of HB 3588 has given TxDOT the authority to build and manage rail infrastructure or aid local governments on passenger and freight rail projects for the first time, however it also put in place strict financial restrictions which limit the dollar amounts available for TxDOT's investment in rail facilities (79). HB 3588 Article 4 spells out the limits under which TxDOT may participate in the provision of rail facilities. It specifically gives TxDOT the authority to acquire, finance, construct, operate, and maintain a rail facility (83). It prohibits TxDOT from owning railroad rolling stock (i.e., locomotives and/or railcars) and TxDOT employees from operating trains—requiring instead that TxDOT contract with a private operator to operate trains over any rail facility owned by the department, but allows TxDOT to maintain rail facilities either directly or through a private contractor (84).

HB 3588 also placed financial restrictions upon the amount of funding that TxDOT may spend each year upon rail facilities. No more than \$12.5 million per year from state and federal funds may be spent on rail projects, however, this restriction does not apply to funds that are spent to acquire or construct rail lines on Trans Texas Corridor routes; the acquisition of abandoned rail lines; funding from bonds, private investment, donations, or grants from the FRA or the Federal Transit Administration (FTA); or funds spent on grading and bed preparation (85). These exceptions potentially allow TxDOT's involvement to significantly exceed the \$12.5 million dollar annual cap from the state highway fund through use of bond programs such as the Texas Mobility Fund and through leveraging state funds to receive larger amounts through existing federal loan programs. This gives TxDOT the flexibility to do many different types of rail projects throughout the state. In relation to this project, it also opens up many possibilities for structuring PPPs that would not have been possible prior to the passage of this legislation.

## **PPP PARTICIPANTS AND LIKELY SCENARIOS**

While much of this report has evaluated two-party PPPs between TxDOT and a rail company, there are, in fact, many other potential participants, from both the public and private sector, that might be interested in taking part in a rail infrastructure related PPP. The number of possible combinations makes it impossible to list all such partners. This section will list several potential partners from both the public and private sectors that might participate in general rail-based projects and then suggest some likely scenarios for partnerships that might form specifically for funding enhanced intermodal service. While not exhaustive, these examples are the most likely participants in future PPPs.

### **Examples of Potential Public Participants in Rail-Related PPPs**

- **Texas Department of Transportation** – As the state agency responsible for overall transportation planning, including rail, TxDOT has an important role in preserving and/or making improvements to the state's rail infrastructure that will aid it in fulfilling its mission in the movement of people and goods. TxDOT will need to partner with private rail companies to accomplish many of these projects.
- **Local (County and City) Governments** – Often local governments have rail transportation priorities that they are interested in seeing advanced, however, they do not



have the funding to complete them by themselves. In such situations, partnering with the state and/or private rail companies may be the only way to accomplish these goals.

- **Metropolitan Planning Organizations (MPOs)** – MPOs prioritize and program funding for transportation projects within the urbanized areas (>50,000 population) of the state. MPOs could desire to participate in rail projects that improve traffic safety or that generate environmental/societal benefits within their boundaries.
- **Regional Mobility Authorities (RMAs)** – RMAs are new governmental bodies that have been granted certain taxing powers within their region for funding of transportation improvements that will increase mobility. Projects are not restricted to the highway mode alone and some RMAs may choose to fund passenger or freight rail projects as part of their overall mobility improvement planning.
- **Rural Rail Transportation Districts (RRTDs)** – RRTDs are sub-divisions of state government created to preserve rail infrastructure that have the power to own, construct, operate, and maintain rail and intermodal facilities. RRTDs could work with TxDOT to secure funding and provide local management and oversight for shortline rail operations. Those owning facilities in or near urban areas may also allow commuter or other types of passenger rail to use their infrastructure.
- **Port Authorities** – Port authorities might participate in rail projects that would benefit the port by providing better landside access for both people and goods.
- **Airport Boards** – Airport boards might participate in rail projects that improved movement of passengers or freight to airport facilities.
- **Transit Agencies** – Transit agencies in the urban areas of the state might become partners on rail projects that created opportunities for rail transit or right-of-way acquisition for rail or bus transit facilities.
- **Commuter Rail Districts** – Intercity commuter rail districts might partner on projects that increased rail capacity allowing for commuter rail operations. Commuter rail also qualifies for certain federal transit grant programs that could be used to help fund the project.
- **State-supported Institutions of Higher Education** – State universities often have large financial reserves that are invested for provision of future educational opportunities. Some state officials have suggested that these funds could be invested in transportation

projects, including rail projects that had a potential for financial return or that produced other benefits to the university such as increased connectivity to urban areas and/or other educational and business institutions.

- **School Districts** – Local school districts could potentially become involved in rail projects where the transportation needs or safety of students were involved. Provision of improved transportation of students, the movement of a rail line away from school property, or purchase of improved warning devices at a highway-rail grade crossing nearby a school are examples of possible school district interest.
- **Other State and Federal Agencies** – Almost always other interests, in addition to transportation, play a role in rail transportation projects. This means that other state and federal agencies may be interested in participating in the project. For example, the state’s economic development agency or agriculture department may also be interested in partnering to meet their goals for job creation or agricultural movement, respectively.

#### **Examples of Potential Private Participants in Rail-Related PPPs**

- **Railroad Companies** – Private railroad companies have existing rail infrastructure but limited funding available for added capacity or expansion of their systems for new services. By partnering with the public sector, private rail companies may be able to open new markets for themselves and benefit the public at the same time through diversion of freight and passenger traffic from the highway system.
- **Railroad Contractors** – Railroad contractors, both rail operators and those who specialize in rail construction, signaling, or equipment, may also be interested in partnering. These companies stand to gain in projects where state-owned facilities may require their services for operation or maintenance.
- **Highway Construction Firms/Infrastructure Firms** – Major construction firms that now specialize in the building of highway facilities may be interested in participating in projects that have both highway and rail features. These companies may branch out into rail construction or simply take part in the highway construction portion of such a partnership. Their experience in management and execution of large construction projects may also be of great benefit to any PPP team.

- **Consortia/Joint Ventures** – Several private firms may choose to form subsidiaries or joint ventures for a specific project. This model has been evident in recent large TxDOT projects such as SH-130 and initial proposals for construction of the high-priority routes of the Trans Texas Corridor.
- **Operations and Maintenance (O&M) Companies** – Companies that specialize in the operations and maintenance of large transportation facilities may wish to partner in order to participate in O&M of the facility following construction.
- **Trucking Companies** – Trucking companies might be interested in participating in rail projects that could meet specific performance standards for movement of their cargoes which either augment or improve their truck or driver availability. Rail service that can move TOFC or COFC quickly and efficiently for relatively long segments of the trip can enhance truck operations by freeing up drivers and tractors for other purposes, thereby reducing maintenance, fuel, and personnel costs.
- **Third Party Logistics (3PL) Companies** – 3PL companies are contractors that take responsibility for making sure that a company’s freight products are delivered on time. 3PL companies choose the mode by which that freight should move. Rail projects that increase delivery reliability and/or reduce the costs of delivery may interest 3PL companies enough to participate in a PPP that could provide such a service that would move their contracted freight.
- **Private Investment Firms** – The prospect of a rail project generating a long-term profit may be high enough to interest a private investment firm to participate. The return on investment for the company would have to outweigh the risks associated with the project. The interest of the private financial firms would be largely dependent on the projected traffic or ridership of any such rail project.

### **Possible Scenarios for Enhanced Intermodal Services**

Below are five possible scenarios through which TxDOT could possibly participate in a partnership that provides an enhanced intermodal service. This list is not meant to exclude other possibilities, but merely to give examples of possible structures and objectives that might drive team formation.

### ***TxDOT/RMA/RRTD Fund Railroad Corridor Shuttle Services for TOFC/COFC***

In this scenario, state entities such as TxDOT, a Regional Mobility Authority, a Rural Rail Transportation District, or a combination of these entities would partner with a railroad company to provide additional intermodal rail services in a heavily congested truck corridor. Government involvement and funding assistance is typically necessary for rail movements of less than 500-700 miles where rail rates and delivery times become more competitive with trucks. In concept, this type of partnership would work in this manner. Funds from one or more of the state entities would subsidize rail companies to a level that allowed them to charge rates that are competitive with trucking companies at these distances. Rail companies could earn a reasonable profit in accordance with the partnership agreement and, in exchange, the state would benefit by reducing the number of shipping containers and trailers using the existing highway system thereby decreasing congestion and maintenance costs.

If the costs to participate in such a partnership were less than or equal to the costs saved in reduced maintenance or reduced construction to handle increased traffic, such a partnership would make sense for the state to consider. Other societal benefits such as environmental benefits and traffic safety could also be taken into account. For the railroad companies, the ability to generate a reasonable rate of return based upon the state investment could potentially make this type of project feasible. Potentially, trucking companies might also benefit by concentrating drivers' efforts upon delivery from the rail terminals rather than the line segment where rail was used.

The partnership agreement and conditions for each project of this type would have to be negotiated between the parties at the outset to ensure that each partner's role, responsibilities, and expected return was clear. Also, TxDOT's interpretation of HB 3588 may require that the state have an ownership role in some fixed assets in order to participate. The state constructing and owning some fixed assets that make TOFC/COFC service possible, such as an intermodal terminal, might satisfy this requirement as opposed to the state purely subsidizing new intermodal train service by the private railroad company.

### ***TxDOT/Federal Track Improvements in a Specific Corridor***

In this type of partnership, TxDOT, on its own or as a pass-through agency for federal loans or grants, would partner with a private railroad company to make infrastructure improvements along a specific corridor in order to achieve transportation benefits that have a

statewide or national benefit. For example, rail improvements in the congested NAFTA corridor through Texas might be considered in order to divert some of the current truck freight from Interstate 35. In fact, construction of a railway along a portion of Interstate 35 to handle increasing freight traffic was considered as one alternative during the 1999 *Interstate 35 Trade Corridor Study* although this option was not a part of the finally recommended strategy (56).

This form of partnership would instead have public agencies incrementally invest in improvements to existing rail corridors to improve their speed and efficiency—thereby increasing their competitiveness with truck-only solutions. Railroad companies would benefit by gaining a more efficient and capable rail system and public agencies would benefit by reduced highway maintenance and decreased congestion-related construction/expansion costs. By focusing funds in a designated corridor, transportation improvements over a longer travel segment could potentially be realized.

As in the previous example, roles for each of the participants and desired performance measures would need to be spelled out in advance before public funds could be invested in the private rail network. Limited public ownership roles for certain components of the system might have to be devised before state funds approved by HB 3588 or from the State Infrastructure Bank (SIB) could be allocated to such a project by TxDOT. In other cases, federal loans or grants or highway fund reimbursements might be approved in which TxDOT played an administrative or oversight role for truck diversion to intermodal movement. The acceptability to the railroad company of allowing any such limited supervision of rail operations by a public entity might also be a challenge to forming a partnership of this type.

### ***Texas Mobility Fund/GARVEE-type Bonding for PPPs***

The approval of additional funding mechanisms in the past two legislative sessions by TxDOT have opened up a myriad of possibilities that did not exist previously for rail-related/intermodal PPPs in Texas. The availability of bonding programs such as the Texas Mobility Fund to provide rail infrastructure, as one option among many to relieve urban congestion, may appeal to the fund's users. It is possible that stable (i.e., known and steady quantities) funding available for rail purposes as provided in HB 3588 or the creation of a more stable federal funding source for rail infrastructure could allow GARVEE-type bond financing of rail facilities.

As new financial tools such as these become available, a larger variety of PPP forms may become viable.

## **GUIDELINES FOR SETTING UP ENHANCED INTERMODAL PPPS IN TEXAS**

Several types of recommended guidelines for the creation of PPPs in Texas could be made, however this report will limit its recommendations to those guidelines that have been proven successful in practice and documented in transportation research literature. The National Cooperative Highway Research Program (NCHRP) published a report in 1999 that conducted in-depth case studies of multimodal transportation project partnerships as well as evaluating data from a database of 58 other multimodal projects (81). NCHRP Report 433 outlines three stages to general partnership development—prior to developing a partnership, developing a partnership, and maintaining a partnership as shown in Table 23. A checklist for each of the steps involved in each of these stages is also included which provides advice on specific issues to consider. An analysis of these steps shows that partnership formation is an on-going process that requires continual effort throughout the life of any project for which a PPP is formed.

In general, partnership development tends to adhere to the following pattern. Under each step, a list of issues to consider based upon the recommendations of NCHRP Report 433 and other sources are listed.

### ***Step 1. Determine the need to form a partnership***

- TxDOT (or another public agency) may lack the financial or technical resources to develop a project “in-house” using internal expertise.
- An evaluation of the public agency’s strengths and weaknesses should be done to determine if the private sector has strengths that can offset the identified weaknesses of the public sector participant(s), thus making the project feasible. If so, formation of a PPP should be explored.

**Table 23: Stages of Partnership Development (81).**

<b>Stage A: Prior to Developing a Partnership</b>
<ol style="list-style-type: none"> <li>1. Reasons for forming a partnership</li> <li>2. Activities prior to deciding to partner</li> <li>3. Activities to activate a partnership</li> <li>4. Identifying stakeholders</li> </ol>
<b>Stage B: Developing a Partnership</b>
<ol style="list-style-type: none"> <li>1. Activities included in kick-off workshop</li> <li>2. Partnership components</li> <li>3. Legislation and other legal issues</li> <li>4. Institutional issues</li> <li>5. Community involvement issues</li> </ol>
<b>Stage C: Maintaining a Partnership</b>
<ol style="list-style-type: none"> <li>1. Internal communication components</li> <li>2. Tracking progress</li> <li>3. Legal issues</li> <li>4. Institutional issues</li> <li>5. Community involvement activities</li> </ol>

**Step 2. Determine the partners needed for project success**

- Careful consideration should be given to which (i.e., how many?) public and private sector partners should be included in the PPP for a given project. Appropriate public agencies should not be excluded because they do not invest funds in the project— they may play an important role in public awareness and/or acceptance of the project. At the same time, however, the addition of too many partners into the PPP can unnecessarily slow down the project development process.
- Private sector participants should generally be limited to those that have skills and/or financial resources that are directly related to the project, its planning, its construction, its operations, or its maintenance.

**Step 3. Identify common goals and resources for partnership members**

- For any PPP to be successful, the goals of each member of the partnership should be clearly understood. Often, public and private sector agencies may have divergent, but compatible goals. For example, a private rail company may participate in a project because it is interested in generating new business and therefore larger profits. This goal could be compatible with TxDOT’s goal of decreasing the number of trucks on the highway for congestion reduction and

maintenance savings or for an environmental agency's goal of reducing truck emissions – differing goals, but common methods of meeting them.

- Each member of the PPP brings its own resources “to the table.” Public agencies may be able to qualify for specific federal or state grants more easily than private entities. Conversely, private firms may have internal holdings that can be brought to bear on the project or their expertise in a certain area may more readily attract private financing or an improved bond rating. Financial, technological, political and other types of resources should all be considered.

***Step 4. Develop a plan/process for dealing with anticipated and unanticipated legal, political, and financial conflicts that may occur***

- Inevitably, difficulties of this type will occur during the life of the project, so having a plan in place to deal with them is a vital part of partnership formation. For example, agreeing to settle disputes through a defined arbitration process rather than through legal means is strongly recommended for any PPP.
- Additionally, methods of handling conflicts over purchasing requirements, project scheduling, and financial matters should all be discussed and codified as part of the partnership agreement.

***Step 5. Clarify roles and responsibilities of each of the partners for all project stages***

- Each party should be aware of their role throughout the project.
- Project roles may vary during the different stages for each partner.
- Leadership roles in the partnership at each stage should be explored and documented.
- Both the scope and extent of the responsibilities of each partner, at each stage of the project, should be determined.

***Step 6. Complete and coordinate the necessary financial and technical planning documents***

- Financial agreements must allow for the different methods of tracking expenditures and follow-up accountability for investments. For example, public agencies generally must comply with accounting principles that are in-line with the Governmental Accounting Standards Board (GASB) in their reporting of financial transactions. Private firms do not have the same set of rules for accounting and may vary from firm to firm. Parties in a PPP must come to some agreement on the accounting practices that will be acceptable in and for the PPP.



- Planning documents should take into account the varying policies and desires that public and private sector firms have regarding project approval and completion schedules. Public sector agencies usually are working from a pre-defined and agency approved planning process that may seem tedious and repetitive to the private sector members of the partnership. Private firms, on the other hand, are typically more flexible and interested in getting the project completed in short order so that their operations can be positively affected through increased efficiency or increased profits (81). The agreement must address expectations and limitations on project completion from both perspectives.

***Step 7. Secure project resources as planned or through alternative means***

- Once a PPP is formed and necessary items are negotiated into an approved project agreement, all parties should begin to pull together the resources (financial and technical) that each has committed to the project.
- Occasionally, planned resources and/or funding options will not materialize as anticipated in the project agreement/planning document and alternative means of replacing those resources must be found. Early identification of alternate funding sources or other firms that can quickly replace a PPP member firm that is in default of the project agreement is vital.
- If at all possible, resources should be identified and solidified prior to completing the project agreement/ PPP formation and planning stage. This may include considerable effort to develop public support for the project.

***Step 8. Build infrastructure/operate service as outlined in project agreement***

- Execution of the project plan should begin as scheduled, if at all possible. Delays in construction or service affect resource availability with each of the partners.

***Step 9. Evaluate conditions and success of partnership and project***

- Operation of a new infrastructure (or new operations over existing infrastructure) should be evaluated to determine if traffic levels/usage are in accordance with the financial and operational projections made before construction.

***Step 10. Negotiate/re negotiate partnership structure as necessary***

- If a project is not meeting the forecast level of service, partners in the PPP should be consulted to identify reasons for this shortfall and suggested methods to address the problem.

- It is possible that changes to the PPP structure and/or membership may be necessary for continued operation of the facility/service.
- Lessons learned should be documented for future PPP formation.

### **Additional Sources for Information on PPPs**

- National Cooperative Highway Research Program (NCHRP) Report 433, *Guidelines for Developing and Maintaining Successful Partnerships for Multimodal Transportation Projects*, Transportation Research Board, National Academy Press, 1999.
- NCHRP Web Document 21, *Volume II- Case Studies of Multimodal Partnerships*, Available at: <http://www4.nas.edu/trb/crp.nsf>.
- NCHRP Web Document 22, *Volume III- Research Report: Developing and Maintaining Partnerships for Multimodal Transportation Planning*. Available at: <http://www4.nas.edu/trb/crp.nsf>.
- U.S. DOT Volpe Transportation Center, *Public/Private Partnerships: Implications for Innovation in Transportation*, December 1998. Available at: <http://www.volpe.dot.gov/infosrc/strtplns/nstc/ppp/>
- U.S. DOT Volpe Transportation Center, *Public/Private Partnerships II: Engines for Innovation in Transportation*, May 2000. Available at: <http://www.volpe.dot.gov/infosrc/strtplns/nstc/ppp2/>
- U.S. DOT Volpe Transportation Center, *Public/Private Partnerships III: Implementing Successful Public/Private Partnerships in Transportation*, February 2002. Available at: <http://www.volpe.dot.gov/infosrc/strtplns/nstc/ppp3/>

## CHAPTER 8: CONCLUSIONS AND RECOMMENDATIONS

### OVERVIEW

Strategic public investment through public-private partnerships in the rail freight network, specifically in enhanced intermodal rail service, has been found to be a possible solution for lessening the state's roadway congestion problem. Many feel that without greater investment in rail infrastructure allowing rail to carry a greater proportion of intercity freight, congestion caused by trucks on Texas' roadways will most certainly increase. Without rail assuming a greater role in the transportation mix, truck traffic is expected to grow as a percentage of total traffic.

This research project analyzed the opportunities for public investment in intermodal rail service through a partnership with railroad companies as a means of achieving this goal. It identifies the importance of synchronizing public and private transportation planning and financing processes that, throughout the past century, have primarily operated in isolation from one another to the growing disadvantage of each. A truly exciting finding is that both the public sector, which faces enormous highway maintenance and construction needs, and the railroads, which often struggle to earn the cost of capital for maintenance and operation of their extensive networks, are increasingly receptive to the idea of collaboration. The railroads are beginning to see alliances with the public sector as an opportunity for mutually beneficial solutions to transportation problems. Matt Rose, President and Chief Executive Officer of BNSF, disclosed "BNSF meets annually with state [departments of transportation] to review plans. In the future, we should be discussing changes in our service that could ease the burden on a state's highway network, as well as the plans of each state that could affect our business, hopefully, positively (86)." Furthermore, Dick Davidson, Mr. Rose's counterpart at UP, believes "that the existing surface rail network, with perhaps some relatively modest capital investment, presents a significantly lower cost and more timely alternative to additional highway spending (87)." With these sentiments in mind, this project was undertaken to help balance and optimize the surface transportation system by maximizing the value of transportation expenditures in both the public and private sectors.

## **PROJECT IMPLEMENTATION**

The concept of public-private partnerships for transportation projects is not new. There are numerous examples of partnerships that have occurred over the past decade for this purpose. The most notable ones include the Alameda Corridor in Los Angeles and the Kansas City Sheffield Junction Flyover. These projects benefited both public and private entities by improving roadway mobility and railroad operations through the elimination of at-grade conflicts and increasing the competitiveness of rail. Recent studies and the multitudes of examples point out the fact that a variety of partnership arrangements currently exist and are possible. The array of options may vary according to existing state and local laws and the availability of federal programs. The success of partnerships may depend on the understanding of the flexibility necessary on both the public and private sides in culminating with a mutually beneficial agreement while analyzing all the possible opportunities. With this in mind, there are several important issues to consider when establishing public-private partnerships.

The first is that the relationship between public and private entities is ultimately predicated on the ability of both sides to receive favorable economic returns. Decision makers, both with the public sector and within the rail industry, will have to consider a large number of issues and at times reconcile competing or conflicting objectives. The ultimate solution requires both entities to work toward common goals.

In Texas, recent initiatives have broadened the scope under which the public sector can participate in public-private partnerships, thus creating new opportunities for the utilization of the transportation network to solve transportation problems in the state. With these new opportunities come new responsibilities and the challenge of understanding the newly created guidelines. This challenge also includes understanding any guidelines created as a result of the rule-making processes.

During the rule-making process it is important to ensure that flexibility is provided for in developing public-private partnerships. The multitude of possible arrangements, along with the vast array of projects possible in seeking transportation solutions, require that the rules established for forming partnerships do not unduly limit the type and form of relationships possible.

## ECONOMIC ASSESSMENT

A successful public-private partnership not only depends on the legal, institutional, and political impediments that must be overcome, but ultimately depends on the financial justification of the project. Public transportation agencies must select the best investments for the public's transportation dollar, while private railroads must increase stockholder value by earning a reasonable return on investments.

In analyzing the economic feasibility of an intermodal project investment, the public entity uses some form of cost-benefit analysis, such as net present value, and the private sector evaluates the rate of return from expected cash flows. A decision-making tool that jointly performs both of these analyses can be useful if it allows each party to understand the full range of costs and benefits accrued by the other. As a result, public and private entities can be confident that their respective investments are not unduly favoring the other party. [Figure 31](#) illustrates this balance that must be achieved by an economic model that is used to analyze the economic feasibility of public-private partnerships.

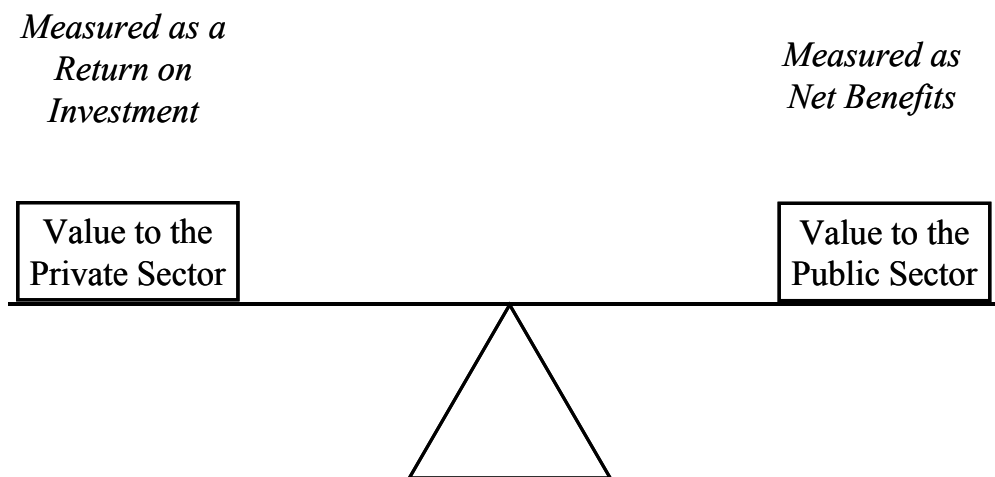

**Figure 31. Balancing the Value of Public-Private Partnerships.**

The economic model developed for this project essentially provides a basic framework for the state to clarify relationships with railroads and describe the effects of assumed costs, benefits, financial requirements, and operating conditions. By understanding each party's financial constraints and decision-making processes, an agreed-upon project funding strategy can be devised. This basic framework provides a critical starting point for evaluating a potential

public-private partnership. It is recommended that a more refined, detailed model be developed subsequent to this project in order to more realistically capture the highly complex financial situations of both parties.

This project examined three corridors as case studies. Each scenario examines a particular transportation corridor, involving both highway and railroad routes, and a specific intermodal solution opportunity. Two of the corridors represent intermodal partnership opportunities identified through research and discussions with the railroads. It should be noted that the results from the model for these corridors are mostly intended to demonstrate the recommended methodology for evaluating the economics of these projects, and not to actually recommend the implementation or rejection of funding for candidate corridors.

Based on information made available for this project, UP's Laredo to Dallas corridor appears to have the greatest chance for mutual economic gains. Perhaps the greatest difference between this corridor and BNSF's Houston to Dallas corridor is the corridor length and the number of trucks assumed to be removed from the highway on a daily basis. Nevertheless, the fact that these analyses were based on limited information on the cost of upgrading infrastructure and trucking industry participation reinforces the fact that additional studies should be made in order to refine each of the input parameters.

## APPENDIX A: ANNOTATED BIBLIOGRAPHY

**American Association of State Highway and Transportation Officials.** “Freight Rail Bottom Line Report,” *Transportation-Invest in America*, Washington, D.C., January 2002.

This report summarizes the nation’s freight rail system and addresses concerns about the capacity of the nation’s freight transportation system over the next 20 years. This document goes into detail about the investment needs and possibilities for the nation’s highways, transit systems, and freight transportation infrastructure. In particular, cost estimates for freight-rail investment is analyzed and a set of potential investment scenarios are generated, based on future demand estimates. The costs and benefits of each scenario are then thoroughly investigated.

**Brown, Thomas and Hatch, Anthony.** *The Value of Rail Intermodal to the U.S. Economy*. Accessed from: [www. Tomorrowsrailroads.com](http://www.tomorrowrailroads.com). June 2003.

This document explains the expected increase in freight transportation demand by the year 2020. A strategy is outlined in the report to help determine which investments in transportation infrastructure will generate the greatest economic impacts. The report explains that investments in highway expansion alone will not be enough to meet future demands. Rather, more public investments in rail intermodal transportation must be made.

**Carmichael, Gil.** *A Column’s Final Thoughts*. Progressive Railroading. Volume 45, No. 10. October 2002.

This is an opinionated freelance article that calls on the leadership of the railroad industries to be more open to new ideas and changes. The article sites specific examples of how the railroads have resisted new ideas in the past and explains how it has hurt them. In particular, the article emphasized public-private partnerships.

**Volume II – Case Studies of Multimodal Partnerships.** NCHRP Web Document 21, Available at: [www4.nas.edu/trblcrp.nsf](http://www4.nas.edu/trblcrp.nsf).

This document looks at several existing multimodal partnerships around the country. The methods of funding, project oversight, parties involved, and other factors of each partnership are discussed in detail.

**CSX.** *Railroad Advantage*. Available at: [www.csx.com/index.cfm?fuseaction=environment.rr\\_advantage](http://www.csx.com/index.cfm?fuseaction=environment.rr_advantage).

This is a brief description of how the railroad industry provides the safest movement of hazardous materials. It also investigates the low emissions emitted from railroads in comparison to other modes of transport.

**Federal Highway Administration.** *Southern California Regional Freight Study.*

A case study is presented in this report of the freight movement system in southern California. The three major markets of its freight system are analyzed; regional and local distribution, domestic trade and national distribution, and international trade. The issues associated with each are investigated, such as funding, planning, and partnerships. A number of issues facing southern California are also discussed such as air quality, congestion, land-use, growth, security, and several others.

**The Freight Rail Solution for Easing Congestion.** Found on-line at: [www.tomorrowsrailroads.com](http://www.tomorrowsrailroads.com). May 21, 2003.

This report provides numerical data and statistics for comparing freight between trucks and freight rail. Their effects on traffic congestion and the environment are looked at as well. The report concludes with suggestions for the federal government on implementing more efficient freight rail service around the country.

**Hunt, Harold D.** *The Road Ahead.* Tierra Grande, The Real Estate Journal. April 2001.

This is a report on the development of the proposed NAFTA highway in Texas, Interstate 69. It explains the need for the system, how it will solve truck congestion, the potential benefits, and it discusses the remaining issues that need to be solved to complete the project.

**International Road Transport Union.** *Comparative Analysis of Energy Consumption and CO<sub>2</sub> Emissions of Road Transport and Combined Transport Road/Rail.* 2002.

This study compares key environmental impacts of transporting freight over European routes by truck to those movements made by a combination of truck and rail. Energy consumption data and carbon dioxide emissions were taken into account to compare the environmental effects of both modes of transport. Several types of intermodal freight transport were researched; containers, rolling highway, swap body, and others.

**International Technology Exchange Program.** *Freight Transportation: The European Market.* United States Department of Transportation, Federal Highway Administration. June 2002.

This document was an international investigation of the issues, constraints, and challenges faced by the European Union in its attempts to develop a common market and how the private sector has responded. Several sponsors contributed to the study of this research such as the Federal Highway Administration, the American Association of State Highway and Transportation Officials, the National Cooperative Highway Research Program, and other transportation officials from Canada and Mexico. The report concludes with recommendations of further studies that can help further understand characteristics of the international market.



**The Lone Star Report.** *LSR Special Issue: Transportation in Texas.* Volume 6, Issue 43; July 26, 2002.

This report summarizes the current traffic demand problem in the state of Texas. It discusses funding issues, freight transportation, inner-city congestion, and several potential solutions.

**Mongelluzzo, Bill.** *Intermodal Bottleneck Ahead.* The Journal of Commerce. Vol. 4 Issue 13. March 31-April 6, 2003.

This document addresses the lack of capacity ahead for the intermodal freight system in southern California. The report suggests that user fees be implemented on container freight so that adequate funding can be gathered to expand the railroad system to double or triple track. Evidence is presented that explains why more public funding is needed for intermodal projects around the country, such as the Alameda Corridor, investigated in this report.

**National Road Authority of Ireland.** *Going Places.*

This document is a description of how public-private partnership can improve roads in Ireland. It briefly describes the need for Public-private partnerships, how the need can be met, and what the benefits are.

**Norment, Richard.** *PPPs- American Style.*

This report discusses the situation of Agroindustry in Latin America, market demand for Agroindustry, its importance and the partnership possibilities. The document then further investigates public-private partnerships and how they can be implemented.

**Partnership to Promote Enhanced Freight Movement at Ports and Intermodal Terminals: A Strategic Plan.** Volpe Center. February 2000.

The document presents a plan for initial implementation strategies for public-private partnerships identified in the 1997 NSTC Transportation Science and Technology Strategy. Opportunities, outcome goals and implementation strategies are all reported in detail within this document.

**Railroad Shipper Transportation Advisory Council.** *White Paper II.* Washington, D.C. April 1999.

This document summarizes the recommendations made to congress by the Railroad-Shipper Transportation Advisory Council. It discusses the distribution of public transportation funds, the connectivity of the rail network, rail capacity and efficiency, and lists proposed regulatory changes.

**Report of Genoa Forum Proceedings.** *Fourth Forum on Intermodal Freight Transport Between Europe and the United States.* April 5, 2001.

This report discusses the current implications of intermodal transport in Europe and the United States. New technologies, such as electronic commerce, are discussed. This document also looks at a few of the recent intermodal projects under way, such as the Alameda Corridor, and discusses their advantages and how they can be applied to future intermodal projects.

**R.L. Banks & Associates, Inc.** *Twin Cities Region Intermodal Terminal Needs Study*. A Report to the Metropolitan Council. January 1995.

The information in this report provides an assessment of needs for terminal capacity in the Twin Cities area to handle intermodal freight and is primarily intended to aid the Minnesota Intermodal Terminal Study coordination group. The document introduces intermodal rail terminal capacity analysis methodology, information on Burlington Northern's St. Paul Intermodal Terminal, and a demand analysis is performed, followed by final conclusions.

**Roop, S. S, J. E. Warner, F. Zambrano, R. Ismailova, and D. H. Kang.** *The Impact of Mexican Rail Privatization on the Texas Transportation System*. Report 2128-2. Texas Transportation Institute, College Station, TX, February 2001.

This report discusses the privatization of Mexico's rail network and the effects of privatization on Texas transportation infrastructure. ...The document concludes that the privatization of the Mexican rail network will result in a significant increase in rail traffic that will serve to partially offset the growth in truck traffic.

**Texas Department of Transportation.** *Creating Tomorrow's Transportation System Strategic Plan 2003-2007*. Statement of the Governing Board of the Texas Department of Transportation. March 2002.

This report outlines the major initiatives for TxDOT over the next 4 years. Led by Governor Rick Perry, TxDOT commissioner Ric Williamson, and others, the document specifies agency objectives, measures, and performance targets for each. In addition, a budget strategy is outlined with five steps and corresponding outputs and efficiencies are listed for each. The report concludes by describing current challenges facing the state of Texas and possible solutions that can be undertaken.

**Texas Transportation Commission.** *Texas Transportation Partnerships*. A report for the citizens of Texas. Texas Department of Transportation, August 2001.

This report outlines a vision for the Texas transportation system. It then expresses the need for newer and stronger partnerships and provides examples of current successful partnerships and strategies. The document then discusses how mobility, safety, and project delivery can all be improved to help the economy of Texas.

**UNEP.** *Rail on Track of Sustainable Mobility*. January 2002.

This report discusses the rail infrastructure on a global scale and its advantages over other modes of transport. The document calls on the rail sector to build on its social and environmental advantages while indicating a modal shift to rail may be necessary in some areas and that increases support for rail from the public sector should continue.

**U.S. Department of Transportation.** *Addendum to the 1997 Federal Highway Cost Allocation Study Final Report*. Federal Highway Administration, May 2000.

This Addendum to the 1997 Federal Highway Cost Allocation Study presents estimates of the costs of highway use not borne directly by transportation agencies. This includes crash costs, air pollution, congestion, noise, and other societal and economic costs. These costs are estimated to range from \$30 billion to \$349 billion per year.

**Virginia Department of Rail and Public Transportation.** *Potential for Shifting Virginia's Highway Traffic to Railroads*. Commonwealth of Virginia. 2001.

The objective of this paper is to address, to the Secretary of Transportation, the need and possibility of diverting highway traffic from Interstate 81 into rail transport. A number of factors are measured and analyzed that could determine if this type of project would justify using public funding for the rail improvements.

**Washington Department of Transportation.** *Benefits of Rail Freight Study*. Found on-line at [www.wsdot.wa.gov/rail/plans/DTA/default.cfm](http://www.wsdot.wa.gov/rail/plans/DTA/default.cfm). June 2003.

The objective of this report is to quantify the benefits of railroad freight transportation in Washington State. Two scenarios are investigated for improving benefits. One is shifting the freight moved by rail to combination trucks and the other is converting short-line railroads to trucks. The overall goal of the study is to show the rail system's value as one part of our transportation system.

**Wilbur Smith Associates and HNTB Corporation.** *Corridor 18 Special Issues Study*. Final Report. May 1997.

This report is a continuation of Corridor 18 and Corridor 20 feasibility studies. In particular, this document investigates three major issues associated with future location and environmental impacts of the corridor. This document also provides cost estimates, economic analysis, efficiency benefits, and traffic impacts of the corridor.



## APPENDIX B: GLOSSARY OF SELECTED REPORT TERMS

**BLOCK SECTION**—a section of track in a fixed block system which a train may only enter when it is not occupied by other trains (88).

**CIRCUS LOADING**—Manner of loading truck trailers on rail flatcars by backing the trailer onto the flatcars from a ramp with a yard tractor.

**CLASSIFICATION YARD**—A railroad terminal area where railcars are grouped together to form train units (89).

**COST-BENEFIT ANALYSIS**—An economic measure, typically undertaken by the public sector, of the feasibility of transportation projects or investments. Examples of cost-benefit analyses include net present value and benefit/cost ratio.

**DIRECTIONAL OPERATIONS**—A manner in which railroads increase train throughput and safety by transporting opposing trains on separate parallel routes. This is also called Directional Running.

**DOUBLE TRACK**—Two main tracks, upon one of which the current of traffic is in a direction specified by railway rules, and upon the other track in the opposite direction.

**DRAYAGE**—The movement of a container or trailer to or from the railroad intermodal terminal to or from the customer's facility for loading or unloading (90).

**INTERMODAL**—Denotes movement of cargo between transport modes (89).

**CONTAINER ON FLATCAR (COFC)**—An intermodal shipping container moving via rail on a railroad flatcar.

**DOUBLE STACK COFC**—Railcar movement of containers stacked two high (89).

**TRAILER ON FLATCAR (TOFC)**—A highway truck trailer moving via rail on a railroad flatcar. Trailers are either lifted onto the flatcars or driven onto the flatcars by a yard tractor, a practice known as circus loading.

**INTERMODAL YARD**—A railroad terminal area where railcars are intermodal containers or trailers are loaded and unloaded. These facilities are usually dedicated for this purpose but may be located in conjunction to a classification yard.

**INTERMODAL CONTAINER**—A freight container designed and constructed to be used interchangeably in two or more modes of transport (89).

**DOMESTIC CONTAINER**—Intermodal containers utilized within the U.S. These containers closely resemble the typical over-the-road trailers in length, i.e., 53 ft.

**INTERNATIONAL CONTAINER**—Intermodal containers utilized in international shipping by ship. These containers are either 20 ft or 40 ft.

**INTERNAL RATE OF RETURN**—A measure of economic feasibility often utilized by the private sector for transportation projects or investments. This method solves for the interest rate that equate the equivalent worth of an alternative's cash inflows to the equivalent worth of cash outflows (91).

**JOINTED RAIL**—Rails of standard length which are bolted together at the ends. Current practices favor upgrading jointed rail to continuously welded rail.

**LESS THAN TRUCK LOAD CARRIERS (LTL)**—Less than truck load companies serve customers who have insufficient amount of cargo to make up a full truck load. Less than truck load operations include mixing shipments of different customers and making multiple stops at each customer. Examples of LTL carriers are United Parcel Service and Federal Express.

**MAIN LINE**—That part of a transportation railway system, exclusive of switch tracks, branches, yards and terminals.

**MODAL SPLIT**—The proportioning of trips between travel modes (i.e., truck or rail).

**MODE**—A particular form or method of travel for people or goods.

**OPERATING EXPENSES**—The expense of furnishing service, including the expense of maintenance and depreciation of the plant and infrastructure used in the service.

**PASSING SIDING**—A track auxiliary to the main track for meeting of passing trains.

**RAIL CAPACITY**— The maximum number of trains which may be operated through a line (88).

**REVENUE**—Income from all sources.

**RIGHT-OF-WAY**—Lands or rights used or held for railroad operation.

**SHIPPER**—The individual or institution that originates a shipment.

**SINGLE TRACK**—A main track upon which trains are operated in both directions.

**TON-MILE**—(a) A unit used in comparing freight earnings or expenses – the amount earned from, or the cost of, hauling one ton of freight one mile. (b) The movement of a ton of freight one mile.

**TRACKAGE RIGHT**—An agreement through which a railroad obtains access and provides service over tracks owned by another railroad where the owning railroad retains the responsibility for operating and maintaining the tracks.

**TRAIN CONTROL SYSTEMS**—A block signal system under which train movements are authorized by block signals whose indications supersede the superiority of trains for both opposing and following movements on the same track.

**AUTOMATIC BLOCK SIGNALS (ABS)**—System of signals that automatically indicates to trains about to enter a segment of track whether it is occupied by another train.

**CENTRALIZED TRAFFIC CONTROL (CTC)**—A system to control the movement of trains by means of remotely controlled signals and switches from a central location by a dispatcher.

**TRACK WARRANT CONTROL (TWC)**—A method to authorize train movements on a main track within specified limits (92).

**TRUCK LOAD CARRIERS (TL)**—Truck load companies serve large customers who have sufficient amount of cargo to make up a full truck load and thus do not need to mix shipments of different customers. Truck load operations usually travel from the origin directly to the destination (93).

**WELDED RAIL**—Rails of standard length which are welded together at the ends to form a single rail.





## REFERENCES

1. Giblin, Jim. "Are Truckers Lucky? Or Just Better? How Motor Carriers Took Fast Freight Away from Railroads." *Trains Magazine*, Vol. 61, No. 11, November 2001, pp. 54-57.
2. U.S. Department of Transportation. Bureau of Transportation Statistics. *North American Transportation in Figures*. BTS-00-05. Washington, D.C., 2000.
3. Chopra, Sunil. *Supply Chain Management: Strategy, Planning and Operation*. Upper Saddle River, New Jersey: Prentice Hall, 2001.
4. Federal Highway Administration. Office of Freight Management and Operation. *Expenses per Mile for the Motor Carrier Industry: 1990 through 2000 and Forecasts through 2005*. Washington, D.C., 2001.
5. Association of American Railroads. *Falling Railroad Rates: Billions of Dollars in Shipper Savings*, July 2003. Online. Available: [www.aar.org](http://www.aar.org).
6. Association of American Railroads. *Railroad Issues*. 106<sup>th</sup> Congress, 2<sup>nd</sup> Session, Washington, D.C., January 2000.
7. Goldsby, Thomas J. Professor, Department of Marketing and Logistics, Ohio State University. "Topic 4: Motor Transportation." Lecture Notes. Business Marketing and Logistics 784, Autumn 2002.
8. Guenther, David. "More Competition, Capacity Needed for Freight Rail in Texas." *The Lone Star Report*, Vol. 6, No 43 July 26, 2002, p. 10.
9. National Science and Technology Council, Committee on Technology, Subcommittee on Transportation Research and Development. *Partnership to Promote Enhanced Freight Movement at Ports and Intermodal Terminals: A Strategic Plan*. Volpe Center, February 2000.
10. U.S. Department of Transportation. Federal Railroad Administration. Office of Safety Assurance and Compliance. *Track Safety Standards Compliance Manual*. Washington, D.C., January 1, 2002.
11. Igoe, Matthew. Senior Manager, Los Angeles Hub Operations, Burlington Northern Santa Fe Railway. Interviewed by Sarod Dhuru, 2003.
12. American Association of State Highway and Transportation Officials, "Freight-Rail Bottom Line Report," *Transportation – Invest in America*. Washington, D.C., January 2003.

13. Dupin, Chris. "Intermodal Will Top Rail Revenue in 2003." *Journal of Commerce*. Online. Available: [www.joc.com](http://www.joc.com) (subscription required). Accessed: 9/20/2002.
14. Association of American Railroads, *Railroads and Highway Congestion*, January 2003. Online. Available: [www.aar.org](http://www.aar.org). Accessed: 02/20/2003.
15. Wilson, Robert, TxDOT Design Division, "Testimony before the House Committee on Transportation." March 25, 1998.
16. Federal Highway Administration [Internet]. Washington, D.C.: Addendum to the 1997 Federal Highway Cost Allocation Study Final Report; [updated 2000, June 20; cited 2003, August 10]. Available at: <http://www.fhwa.gov/policy/hcas/addendum.htm>.
17. Association of American Railroads, *Railroads: Building a Cleaner Environment*, January 2003. Online. Available: [www.aar.org](http://www.aar.org). Accessed: 02/20/2003.
18. Phillips, Don. "Fast Freight's Future." *Trains Magazine*, Vol. 61, No. 11, November 2001, pp 58-65.
19. Fryer, Don, Terminal Operator, and Joe Adams, Chairman's Special Representative, Union Pacific Railroad, Houston, TX. Interview, November 19, 2002.
20. Seaman, Gail, Manager Hub Operations, Business Unit Operations & Support, BNSF Railway, Houston, TX. Interview, November 19, 2002.
21. Shelton, Ben. General Director, Premium Operations; Wint Marler, Senior Manager Intermodal Terminal Operations; and Joe Adams, Chairman's Special Representative, Union Pacific Railroad, Dallas, TX. Interview, December 4, 2002.
22. Burlington Northern Santa Fe Railway. *BNSF Alliance Intermodal Facility Fact Sheet*. Received via Email, August 2003.
23. Union Pacific Railroad. "Union Pacific Railroad Officially Opens New \$181 Million Chicago Region Intermodal Facility" *News Releases*. Omaha, NE, August 27, 2003. Online. Available: [www.uprr.com](http://www.uprr.com).
24. Union Pacific Railroad. "UP Opens Intermodal Terminal in Marion, AR." *News Releases*. Omaha, NE, July 10, 2002. Online. Available: [www.uprr.com](http://www.uprr.com).

25. Burlington Northern Santa Fe Railway. "BNSF Logistics Park – Chicago Opens Creating New Model for Freight Logistics." *News Release*. Fort Worth, TX, October 14, 2002. Online. Available: [www.bnsf.com](http://www.bnsf.com).
26. "Expedited Rail Services Gain Ground on Trucking." *Logistics Management*. September 1, 2003. Online. Available: [www.manufacturing.net/lm/](http://www.manufacturing.net/lm/).
27. U.S. Department of Transportation. *The Comprehensive Truck Size and Weight Study Final Report*, Washington, D.C., Vol. 2, Chap. 4, p. IV-35, 2000.
28. U.S. Department of Transportation, Federal Highway Administration, International Technology Exchange Program, *Freight Transportation: The European Market*. Washington, D.C., June 2002.
29. Union Pacific Railroad. *Intermodal*. Online. Available: [www.uprr.com](http://www.uprr.com). Accessed: 9/25/2003.
30. Burlington Northern Santa Fe Railway. *BNSF Intermodal*. Online. Available: [www.bnsf.com](http://www.bnsf.com). Accessed: 9/24/2003.
31. Kansas City Southern Railway. *Automotive and Intermodal*. Online. Available: [www.kcsi.com](http://www.kcsi.com). Accessed: 9/24/2003.
32. Intermodal Association of North America. "Rail Looking for Growth Target Short-Haul Intermodal." *IANA News*. February 2003. Online. Available: [www.intermodal.org](http://www.intermodal.org).
33. Stagl, Jeff. "Pay on Delivery." *Progressive Railroading*. Vol. 46, No. 4, April 2003, pp. 33-37.
34. McClellan, Jim. Senior Vice-President of Planning, Norfolk Southern Corp. "Short-Haul Intermodal: The Norfolk Southern Experience." Presentation. Transportation Research Board, Washington, D.C., January 2003.
35. Gilmore, Paul, Vice President, Expressway, Canadian Pacific Railway. "Equipment Options for Short-Haul Intermodal Rail Markets." Presentation. Transportation Research Board, Washington, D.C., January 2003.
36. U.S. Department of Transportation. "Federal Railroad Administrator Announced Funding for Grade Crossing Hazard Elimination Programs." *DOT News*. FRA 05-03. Washington, D.C., Thursday, September 4, 2003.

37. U.S. Department of Transportation. Federal Highway Administration. Office of Freight Management and Operations. *Freight Analysis Framework*. Online. Available: [www.ops.fhwa.dot.gov](http://www.ops.fhwa.dot.gov).
38. U.S. Department of Transportation. Federal Highway Administration. *Freight Profile – Texas*. Washington, D.C., 2003.
39. Texas Department of Transportation. *Crossroads of the Americas: Trans Texas Corridor Plan*. Austin, TX, June 2002.
40. Alliance I-69 Texas. *Top I-69 Facts*. Online. Available: [www.I69Texas.org](http://www.I69Texas.org).
41. Alliance I-69 Texas. *I-69 Basic Presentation*, October 2002. Online. Available: [www.I69Texas.org](http://www.I69Texas.org).
42. Ports-to-Plains Corridor Coalition. *Map of Routes*. Online. Available: [www.portstoplains.com](http://www.portstoplains.com).
43. U.S. Department of Transportation. Bureau of Transportation Statistics. *U.S. International Trade and Freight Transportation Trends*, BTS03-02. Washington, D.C., 2003.
44. Louis Berger & Associates. *Effect of the North American Free Trade Agreement on the Texas Highway System*. Texas Department of Transportation, Austin, TX, 1998.
45. Union Pacific Railroad. “Reopening of New Braunfels Line Delayed.” *News Releases*, Omaha, NE, October 28, 1998. Online. Available: [www.uprr.com](http://www.uprr.com).
46. Union Pacific Railroad. “Union Pacific Announces \$6.8 million Upgrade Projects in Texas.” *News Releases*. Omaha, NE, October 4, 2001. Online. Available: [www.uprr.com](http://www.uprr.com).
47. Union Pacific Corporation. *Union Pacific 1999 Financial and Operating Statistics*. Online. Available: [www.uprr.com](http://www.uprr.com).
48. Union Pacific Railroad. “Union Pacific Announces \$15.8 million Improvement Plans for Port Laredo Facility.” *News Releases*. Omaha, NE, August 9, 2001. Online. Available: [www.uprr.com](http://www.uprr.com).
49. Chacon, Tony, Assistant Vice President of Mexico Markets, Union Pacific Railroad. Interview, May 23, 2000.

50. Burlington Northern Santa Fe Railway. *BNSF Gulf Division & Texas Division Timetable No. 5*. Online. Available: [www.bnsf.com](http://www.bnsf.com).
51. Burlington Northern Santa Fe Railway, Fort Worth, TX. Meeting with Project Team, December 10, 2002.
52. U.S. Department of Transportation. Bureau of Transportation Statistics. "Rail2m Database." *National Transportation Atlas Databases 2003*. BTS-03-04. Washington, D.C., 2003
53. Interstate Commerce Commission. *Railroad Control and Merger Application, Volume 2, Burlington Northern Railroad Company and the Atchison, Topeka, and Santa Fe Railway Company*. Washington, D.C., October 1994.
54. Williams, Sherry. Director Pricing & Measurement, Burlington Northern Santa Fe Railway. Email, "BNSF Texas Short Haul Intermodal – Response to Your Inquiry," to Sarod Dhuru, April 28, 2003.
55. U.S. Department of Transportation. Surface Transportation Board. *Union Pacific's Fifth Oversight Report*. STB Finance Docket No. 32760 (Sub-No. 21). Filed on July 2, 2001.
56. HNTB Corporation. *I-35 Trade Corridor Study: Recommended Corridor Investment Strategies*. Texas Department of Transportation, Austin, TX, 1999.
57. U.S. Department of Transportation. Surface Transportation Board. *Union Pacific's Third Annual Report on Merger and Condition Implementation*. STB Finance Docket No. 32760 (Sub-No. 21). Served: December 21, 1998.
58. Frailey, Fred W. "Union Pacific's Desert Bloom." *Trains Magazine*. Vol. 62, No. 8, August 2002, pp. 47-65.
59. Union Pacific Railroad. "Union Pacific to Increase Train Speed Through Odessa." *News Releases*. Omaha, NE, October 15, 2002. Online. Available: [www.uprr.com](http://www.uprr.com).
60. Union Pacific Railroad. "Union Pacific to Increase Train Speed Through Abilene, Texas." *News Releases*. Omaha, NE, March 20, 2003. Online. Available: [www.uprr.com](http://www.uprr.com).
61. Union Pacific Railroad. "Union Pacific to Increase Train Speed Through Midland, Texas." *News Releases*. Omaha, NE, March 20, 2003. Online. Available: [www.uprr.com](http://www.uprr.com).

62. Frailey, Fred. "Union Pacific is off to the transcontinental races." *Trains Magazine*. Vol. 62, No. 7, July 2003, pp. 8-9.
63. Oberlender, G. D., *Project Management for Engineering and Construction*, 2<sup>nd</sup> ed., McGraw-Hill Companies, Inc., New York, 2000.
64. Office of Management and Budget [Internet]. Washington, D.C.: OMB Circular No. A-94, Guidelines and Discount Rates for Benefit-Cost Analysis of Federal Programs; [updated 2002, Jan. 22; cited 2003, Aug. 10]. Available: <http://www.whitehouse.gov/omb/circulars>
65. Gomez-Ibanez, J., Tye, W.B., Winston, C., *Essays in Transportation Economics and Policy*, Brookings Institute Press, Washington, D.C., 1999.
66. Resor, R. R., Blaze, J. R., *Short Haul Intermodal: Can It Compete With Truck?*, Zeta-Tech Associates, TRB Annual Meeting, Washington, D.C., 2004.
67. Federal Highway Administration, *1997 Federal Highway Cost Allocation Study*, U.S. Department of Transportation, 1997.
68. Bureau of Transportation Statistics, *Bureau of the Census for Urbanized Area Boundaries*, National Transportation Atlas Database, 2003.
69. Flyvbjerg, B., Holm, M. S., Buhl, S., *Understanding Costs in Public Works Projects: Error or Lie?*, Journal of the American Planning Association, Vol. 68, No. 3, Summer 2002.
70. Sassone, P. G., Schaffer, W. A., *Cost-Benefit Analysis: A Handbook*, Academic Press, Inc., New York, 1978.
71. Higgins, R. C., *Analysis for Financial Management*, 6<sup>th</sup> ed., McGraw-Hill, New York, 2001.
72. Krutilla, J. V., Eckstein, O., *Multiple Purpose River Development: Studies in Applied Economic Analysis*, Johns Hopkins Press, 1958.
73. Pickrell, D. H., *A Desire Named Streetcar: Fantasy and Fact in Rail Transit Planning*, Journal of the American Planning Association, Vol. 58, Spring 1992.
74. Robert L. Nichols, TxDOT Strategic Plan 2003-2007, p. 32.
75. "RAILROADS." The Handbook of Texas Online. Online. Available: <http://www.tsha.utexas.edu/handbook/online/articles/view/RR/eqr1.html> Accessed Wed Oct 1 11:42:39 US/Central 2003 .

76. "RAILROAD CONSTRUCTION, PUBLIC AID TO." The Handbook of Texas Online. Online. Available: <http://www.tsha.utexas.edu/handbook/online/articles/view/RR/mpr1.html>, Accessed Wed Oct 1 11:34:39 US/Central 2003.
77. Savas, E. S., Privatization and Public-Private Partnerships, Chatham House Publishers, New York, 2000, pp. 241-245.
78. William R. Black and James F. Runke. *The States and Rural Rail Preservation: Alternative Strategies*. Lexington, Kentucky: The Council of State Governments, October 1975, p. 4-5.
79. TxDOT, *Drafting the Future*, Austin, TX, 2003, p. 9. Online. Available: <http://www.dot.state.tx.us/DTF/DraftingtheFuture.pdf> Accessed: September 12, 2003.
80. U.S. DOT Volpe Transportation Center. *Public/Private Partnerships: Implications for Innovation in Transportation*, Section II.B., December 1998, Online. Available: <http://www.volpe.dot.gov/infosrc/strtplns/nstc/ppp/chp2.html>, Accessed: 9/30/03.
81. NCHRP Report 433, *Guidelines for Developing and Maintaining Successful Partnerships for Multimodal Transportation Projects*. National Academy Press, Washington, DC, 1999, p. 11.
82. Telephone conversation between TTI staff and Mario Medina, Director of TxDOT Multimodal Section, October 16, 2003.
83. HB 3588, 78<sup>th</sup> Legislature, Regular Session, Article 4, Section 91.002.
84. HB 3588, 78<sup>th</sup> Legislature, Regular Session, Article 4, Section 91.005.
85. HB 3588, 78<sup>th</sup> Legislature, Regular Session, Article 4, Section 91.071(b).
86. *Trains.com Newswire*. "BNSF's Rose: Private-Public Partnerships are a Win-Win for Railroads, States." Online. Available: [www.trains.com](http://www.trains.com).
87. Davidson, Dick, Chairman, Union Pacific Corporation. Letter to Representative Eddie Bernice Johnson, August 21, 2001.
88. Pachl, Joern. *Railway Operation and Control*. Mountlake Terrace, WA: VTD Rail Publishing, 2002.

89. Muller, Gerhardt. *Intermodal Freight Transportation*. 4<sup>th</sup> Edition. Eno Transportation Foundation and Intermodal Association of North America. Washington, D.C., 1999.
90. *UP Intermodal Glossary*. Union Pacific Railroad. Online. Available: [www.up.com](http://www.up.com).
91. Sullivan, William, et. al. *Engineering Economy*. 12<sup>th</sup> Edition. New Jersey: Pearson Education, Inc., 2003.
92. *General Code of Operating Rules*. 4<sup>th</sup> Edition. Washington, D.C., 2000.
93. Wegmann, Frederick, et. al. *Characteristics of Urban Freight Systems*. Report DOT-T-96-22. U.S. Department of Transportation. Washington, D.C., December 1995.



