

Key Materials and Construction Issues of CRCP for Optimum Performance

TxDOT Implementation Project 5-9045-P3

Moon Won
Texas Tech University

Continuously Reinforced Concrete Pavement (CRCP)

- Concrete volume changes due to temperature and moisture variations.
- Transverse cracks develop to accommodate concrete volume changes.
- It is essential that the transverse cracks are kept tight.











JUL 30 2008









03.18.2009 11:58

mw3



Slide 12

mw3

This shows the current condition of the project, about 10 years after the construction, taken in August, 2007.

Moon Won, 10/19/2007

PCC Pavement in Texas

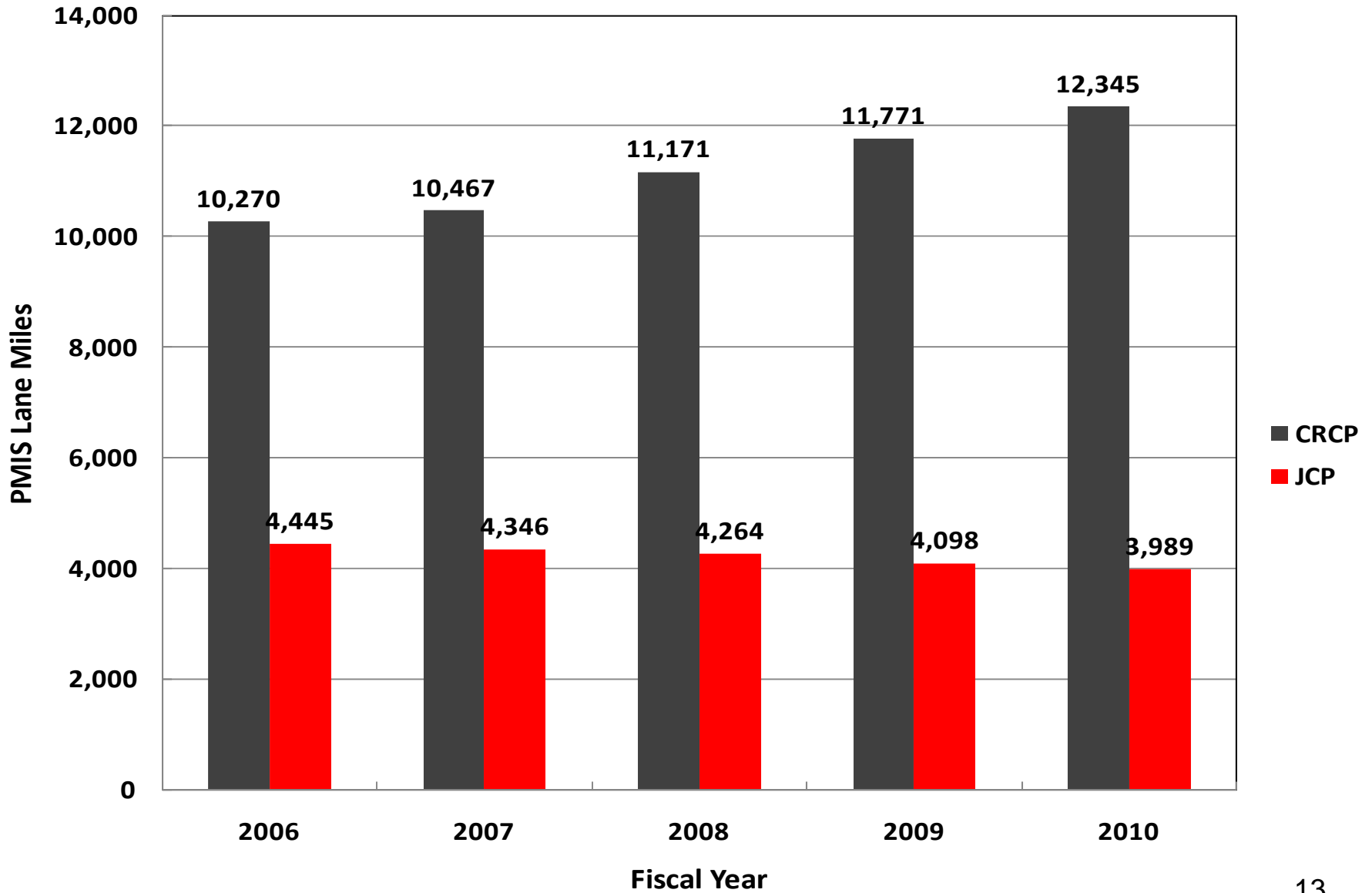

Punchout & Patches in CRCP

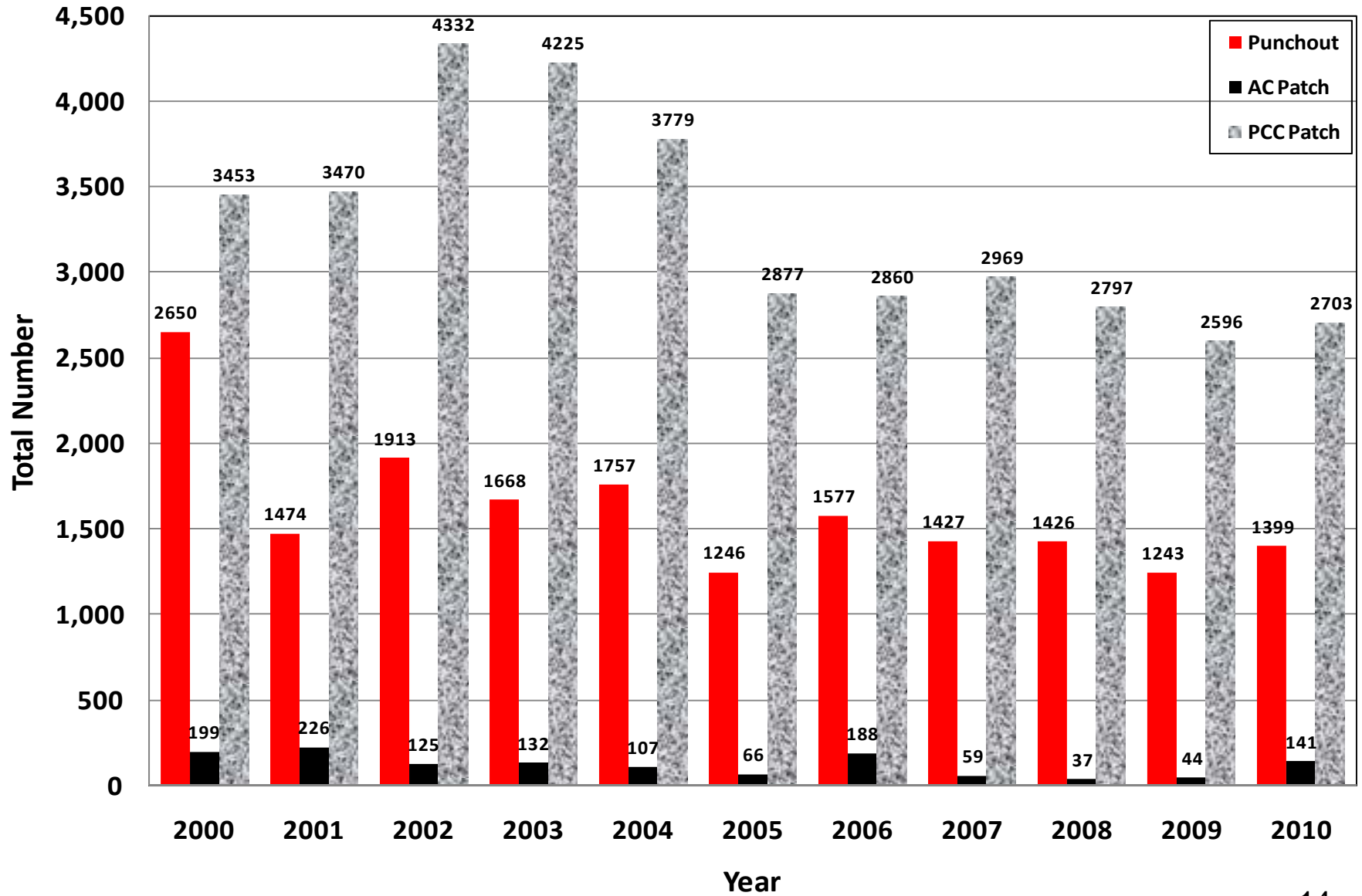

CRCP Distress Rate

(FY 10)

- Punchout: 1 per 8.8 lane miles
- Concrete Patch: 1 per 4.6 lane miles
- Asphalt Patch: 1 per 88 lane miles
- Overall, excellent performance!

Punchouts





Effect of Shoulder Type on Edge Deflections

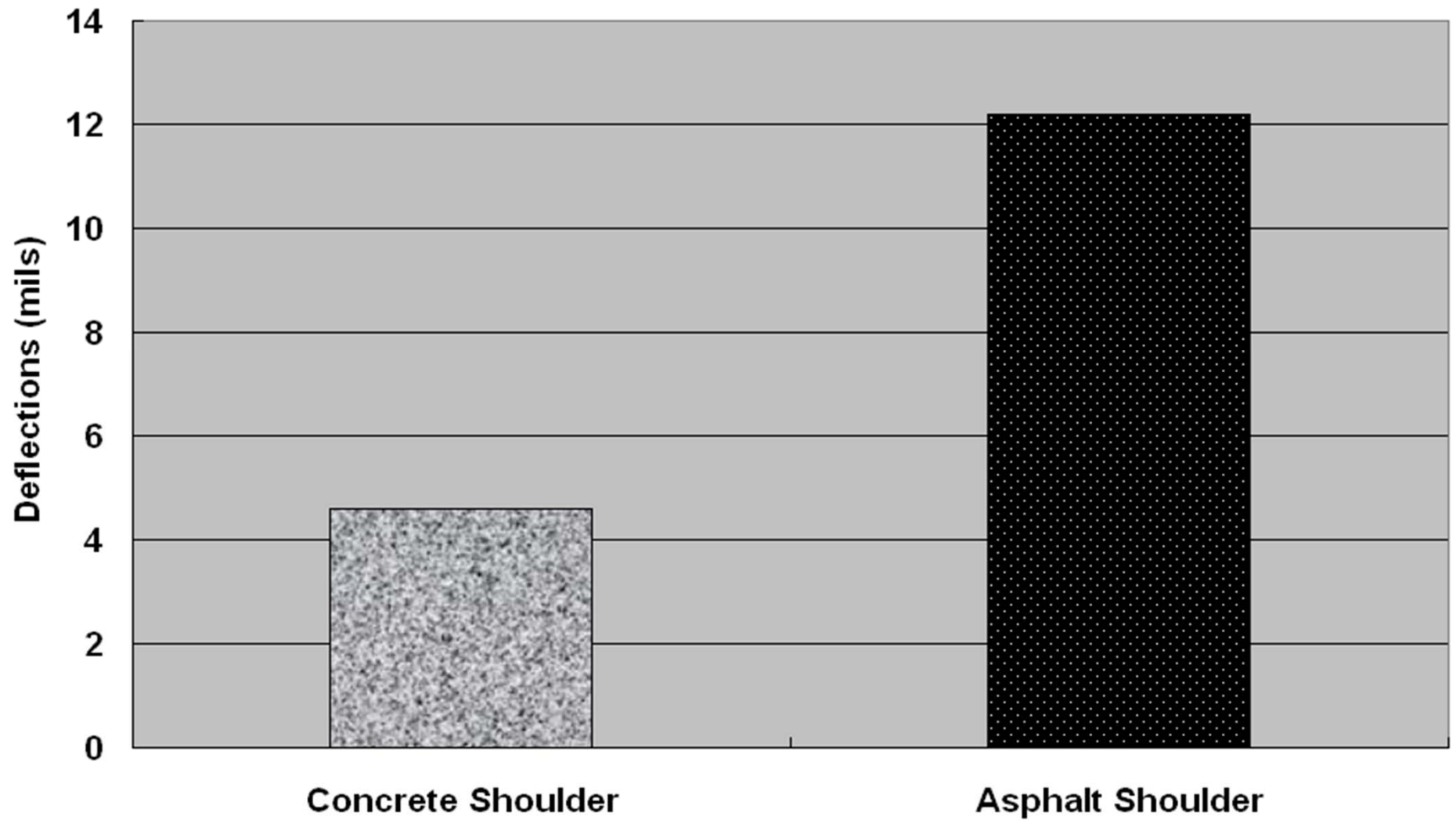

Punchouts – Edge Support Issue





10.30.2011 10:30

Punchouts – Tiebar Issue





Punchouts – Construction Joint Issue







02.18.2010 09:14

25

Punchouts – Repair Joint Issue



Punchouts – Concrete Finishing Issue



Punchouts – Inadequate Consolidation Issue







11.12.2010 12:52

Punchouts – Material Issue







11.11.2010 12:46



11.11.2010 15:26



10.27.2011 15:15





Punchout Distress Type Distribution in Texas

	Classification(PCH Summary based on the Field Survey)									
	PCH	E-PCH	E-PCH-PTB	PCH-CJ	PCH-RJ	BS-PCW				TOTAL
Amarillo	0	0	4	2	6	6				18
Childress	0	0	0	2	0	1				3
Dallas	9	8	1	7	9	7				41
Fort Worth	0	0	0	6	10	12				28
Wichita Falls	1	3	6	10	0	5				25
Houston	1	0	0	21	18	77				117
Sub Total	11	11	11	48	43	108				232
Ratio	4.7%	4.7%	4.7%	20.7%	18.5%	46.6%				100%
	14.2%			20.7%	18.5%	46.6%				

Punchout Distress Type Distribution in Texas

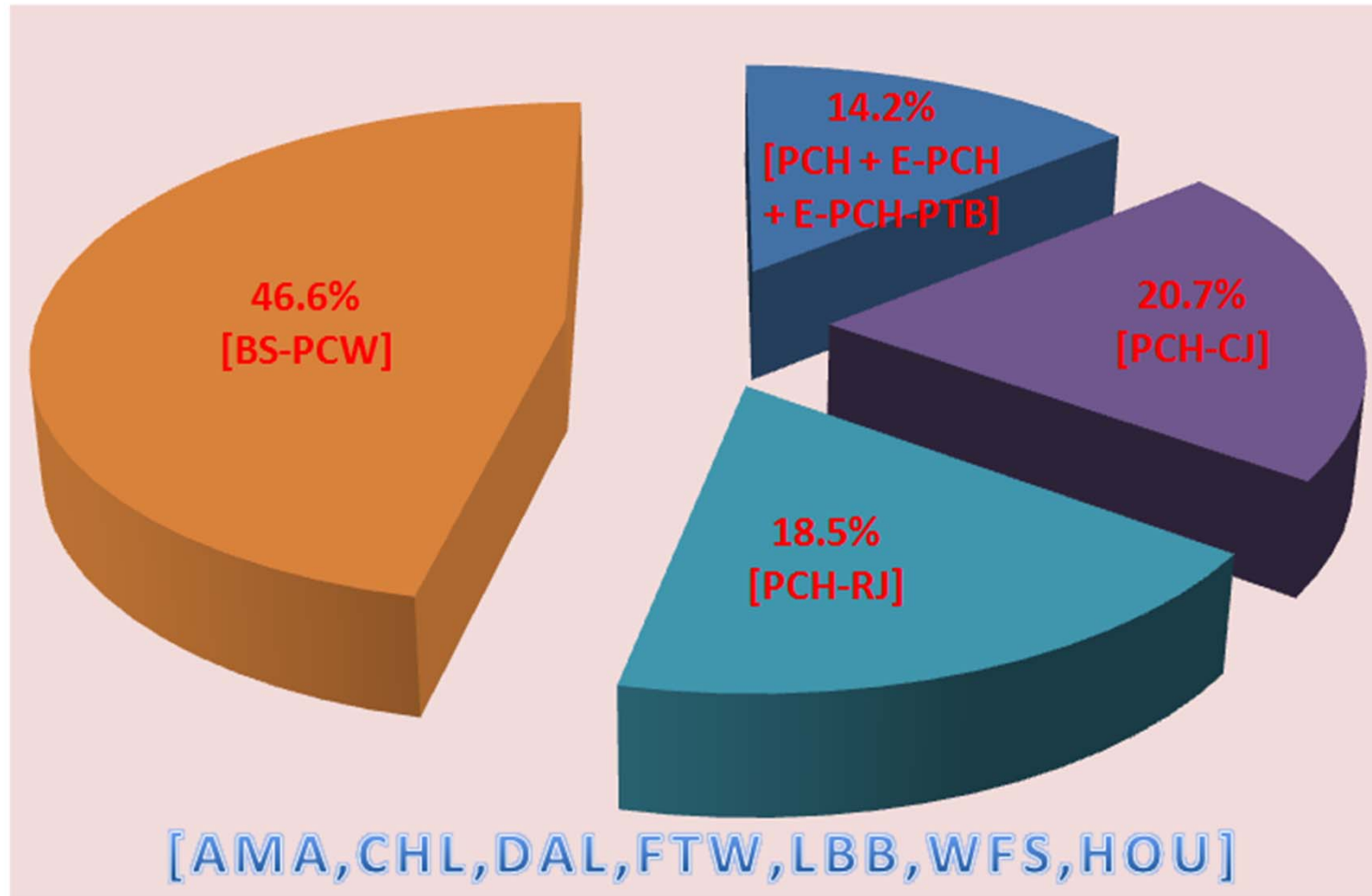

CRCP Design Elements

- Slab Thickness (TxDOT Design Guide)
- Reinforcement
 - Longitudinal steel
 - Transverse steel
 - Tie bars
 - At transverse construction joints

CRCP Design Standards

GENERAL NOTES

1. DETAILS FOR PAVEMENT WIDTH, PAVEMENT THICKNESS AND THE CROWN CROSS-SLOPE SHALL BE SHOWN ELSEWHERE IN THE PLANS. PAVEMENTS WIDER THAN 100 FT. WITHOUT A FREE LONGITUDINAL JOINT, ARE NOT COVERED BY THIS STANDARD.
2. THE DETAIL FOR THE JOINT SEALANT AND RESERVOIR IS SHOWN ON STANDARD SHEET "CONCRETE PAVING DETAILS, JOINT SEALS."
3. ALL THE REINFORCING STEEL AND TIE BARS SHALL BE DEFORMED STEEL BARS CONFORMING TO ASTM A 615 (GRADE 60) OR ASTM A 996 (GRADE 60). STEEL BAR SIZES SHALL CONFORM TO TABLE NO. 1 & 2.
4. STEEL BAR PLACEMENT TOLERANCE SHALL BE +/- 1 IN. HORIZONTALLY AND +/- 0.5 IN. VERTICALLY. CALCULATED AVERAGE BAR SPACING (CONCRETE PLACEMENT WIDTH / NUMBER OF LONGITUDINAL BARS) SHALL CONFORM TO TABLE NO.1 AND AS SPECIFIED.
5. PAVEMENT WIDTHS OF MORE THAN 15 FT. SHALL HAVE A LONGITUDINAL JOINT (SECTION Z-Z OR SECTION Y-Y). THESE JOINTS SHALL BE LOCATED WITHIN 6 IN. OF THE LANE LINE UNLESS THE JOINT LOCATION IS SHOWN ELSEWHERE ON THE PLANS.
6. THE SAW CUT DEPTH FOR THE LONGITUDINAL CONTRACTION JOINT SHALL BE ONE THIRD OF THE SLAB THICKNESS.
7. WHEN APPROVED BY THE ENGINEER, SINGLE PIECE TIE BARS MAY BE USED BY INSERTING INTO PLASTIC CONCRETE AT LONGITUDINAL CONTRACTION JOINTS.
8. WHEN TYING CONCRETE GUTTER AT A LONGITUDINAL JOINT, THE TIE BAR LENGTH OR POSITION MAY BE ADJUSTED. PROVIDE 3 IN. OF CONCRETE COVER FROM THE BACK OF GUTTER TO THE END OF TIE BAR.
9. MISSING OR DAMAGED TIE BARS SHALL BE REPLACED BY DRILLING AND EPOXY GROUTING AT THE CONTRACTOR'S EXPENSE.
10. OMIT TIE BARS LOCATED WITHIN 18 IN. OF THE TRANSVERSE CONSTRUCTION JOINTS. USE HAND-OPERATED IMMERSION VIBRATORS TO CONSOLIDATE THE CONCRETE ADJACENT TO ALL FORMED JOINTS.
11. OBTAIN THE ENGINEER'S WRITTEN APPROVAL, IF THE CONCRETE MIX DESIGN USES MORE THAN 5.5 SACKS/CY.
12. LONGITUDINAL REINFORCING STEEL SPLICES SHALL BE A MINIMUM OF 25 IN.

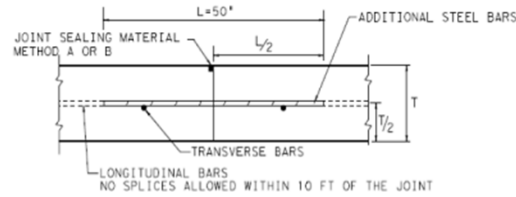

TRANSVERSE CONSTRUCTION JOINT SECTION X - X

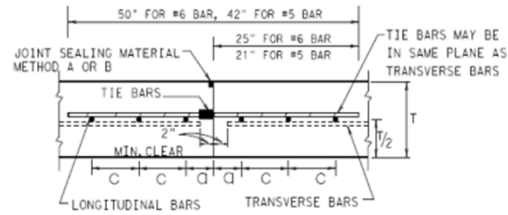

LONGITUDINAL CONSTRUCTION JOINT SECTION Y - Y

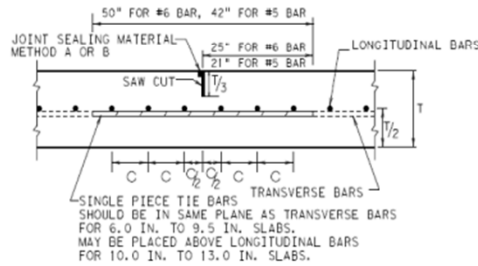

LONGITUDINAL CONTRACTION JOINT SECTION Z - Z

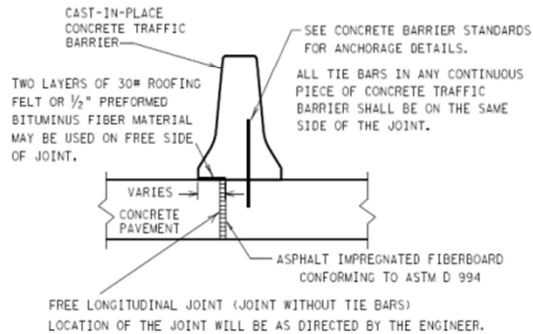

FREE LONGITUDINAL JOINT DETAIL

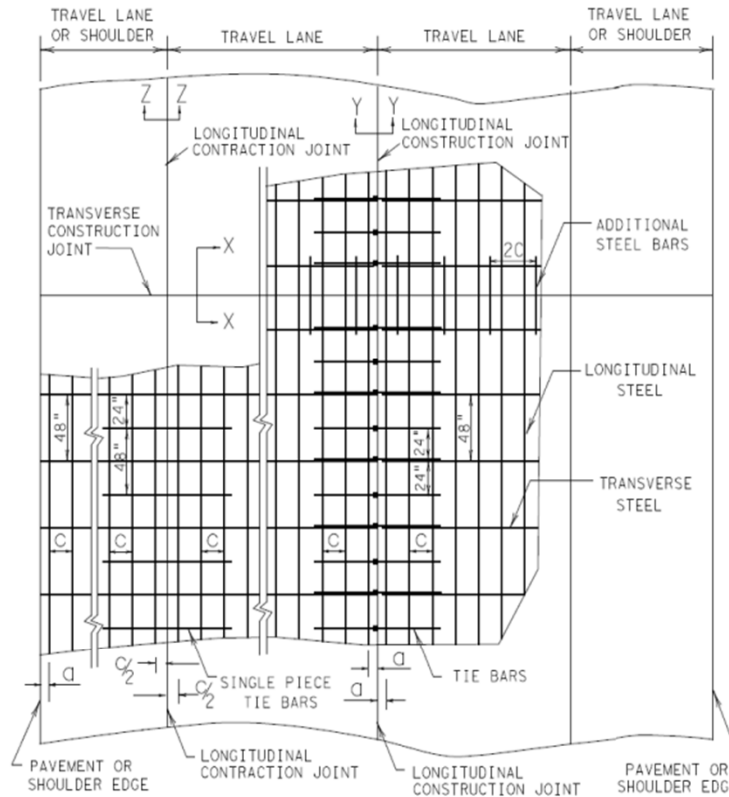

TYPICAL PAVEMENT LAYOUT

PLAN VIEW (NOT TO SCALE)

SLAB THICKNESS (IN.)	TRANSVERSE STEEL		TIE BARS AT LONGITUDINAL CONTRACTION JOINT		TIE BARS AT LONGITUDINAL CONSTRUCTION JOINT	
	BAR SIZE	SPACING (IN.)	BAR SIZE	SPACING (IN.)	BAR SIZE	SPACING (IN.)
6.0 - 7.5	#5	48	#5	48	#5	24
8.0 - 13.0	#5	48	#6	48	#6	24

SLAB THICKNESS AND BAR SIZE	REGULAR STEEL BARS	FIRST SPACING AT EDGE OR JOINT		ADDITIONAL STEEL BARS AT TRANSVERSE CONSTRUCTION JOINT	
		SPACING c (IN.)	SPACING a (IN.)	SPACING 2 x c (IN.)	LENGTH L (IN.)
6.0	#5	7.5	3 TO 4	15	50
6.5	#5	7.0	3 TO 4	14	50
7.0	#5	6.5	3 TO 4	13	50
7.5	#5	6.0	3 TO 4	12	50
8.0	#6	9.0	3 TO 4	18	50
8.5	#6	8.5	3 TO 4	17	50
9.0	#6	8.0	3 TO 4	16	50
9.5	#6	7.5	3 TO 4	15	50

SLAB THICKNESS AND BAR SIZE	REGULAR STEEL BARS	FIRST SPACING AT EDGE OR JOINT		ADDITIONAL STEEL BARS AT TRANSVERSE CONSTRUCTION JOINT	
		SPACING c (IN.)	SPACING a (IN.)	SPACING 2 x c (IN.)	LENGTH L (IN.)
10.0	#6	7.0	3 TO 4	14	50
10.5	#6	6.75	3 TO 4	13.5	50
11.0	#6	6.5	3 TO 4	13	50
11.5	#6	6.25	3 TO 4	12.5	50
12.0	#6	6.0	3 TO 4	12	50
12.5	#6	5.75	3 TO 4	11.5	50
13.0	#6	5.5	3 TO 4	11	50

Texas Department of Transportation
Design Division Standard

CONTINUOUSLY REINFORCED CONCRETE PAVEMENT

ONE LAYER STEEL BAR PLACEMENT
T - 6 to 13 INCHES

CRCP (1) - 11

FILE#	crp111.dgn	DWG TxDOT	CHK LL	DWG HC	CHK
TxDOT	November 2009	COMT	SECT	JOB	MCBANK
REVISIONS					
10/10/2011	ADD ON #12	DIST	COUNTY	SHEET NO.	

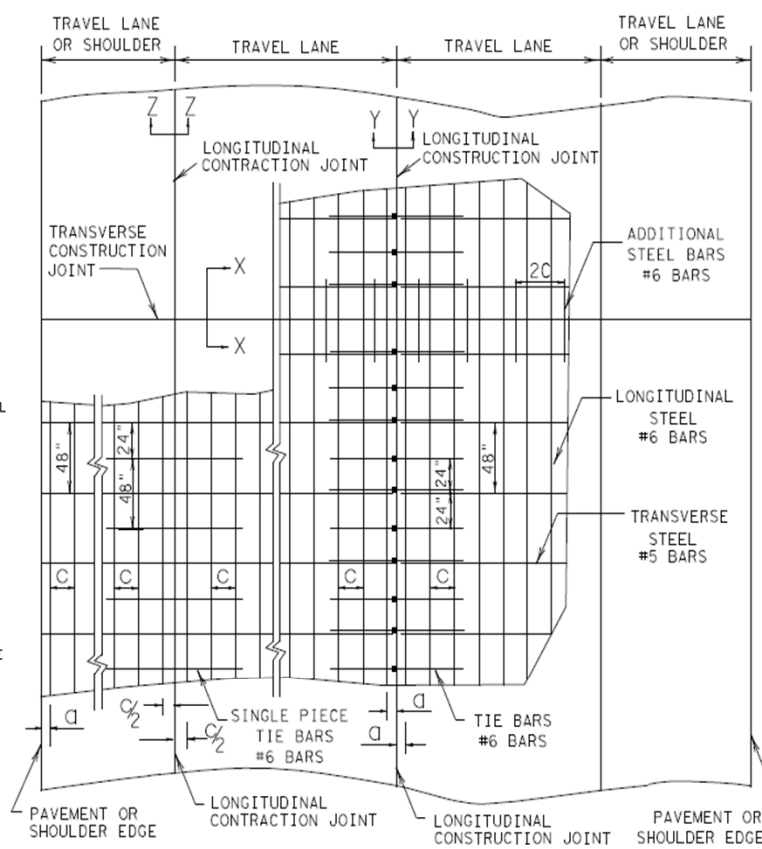
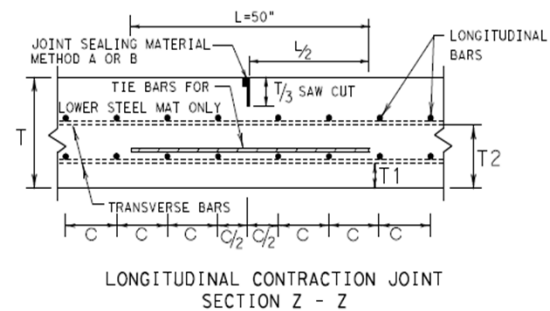
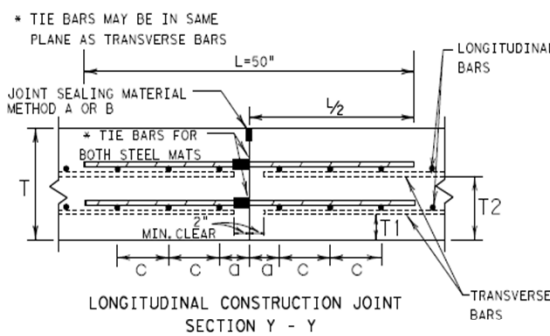
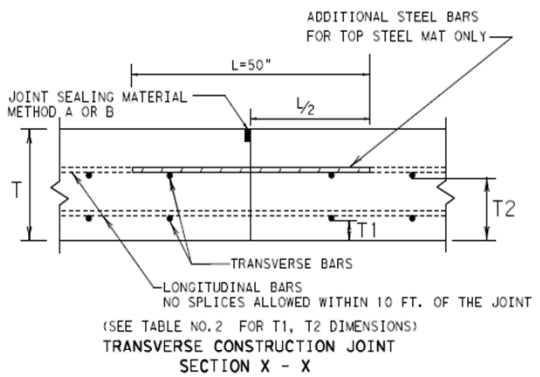

TYPICAL PAVEMENT LAYOUT
PLAN VIEW (NOT TO SCALE)

GENERAL NOTES

1. DETAILS FOR PAVEMENT WIDTH, PAVEMENT THICKNESS AND THE CROWN CROSS-SLOPE SHALL BE SHOWN ELSEWHERE IN THE PLANS. PAVEMENTS WIDER THAN 100 FT. WITHOUT A FREE LONGITUDINAL JOINT, ARE NOT COVERED BY THIS STANDARD.
2. THE DETAIL FOR THE JOINT SEALANT AND RESERVOIR IS SHOWN ON STANDARD SHEET "CONCRETE PAVING DETAILS, JOINT SEALS."
3. ALL THE REINFORCING STEEL AND TIE BARS SHALL BE DEFORMED STEEL BARS CONFORMING TO ASTM A 615 (GRADE 60) OR ASTM A 996 (GRADE 60). USE #5 BARS FOR TRANSVERSE STEEL AND USE #6 BARS FOR LONGITUDINAL STEEL AND TIE BARS.
4. STEEL BAR PLACEMENT TOLERANCE SHALL BE +/- 1 IN. HORIZONTALLY AND +/- 0.5 IN. VERTICALLY. CALCULATED AVERAGE BAR SPACING (CONCRETE PLACEMENT WIDTH / NUMBER OF LONGITUDINAL BARS) SHALL CONFORM TO TABLE NO.1 & 2 AND AS SPECIFIED.
5. PAVEMENT WIDTHS OF MORE THAN 15 FT. SHALL HAVE A LONGITUDINAL JOINT (SECTION Z-Z OR SECTION Y-Y). THESE JOINTS SHALL BE LOCATED WITHIN 6 IN. OF THE LANE LINE UNLESS THE JOINT LOCATION IS SHOWN ELSEWHERE ON THE PLANS.
6. THE SAW CUT DEPTH FOR THE LONGITUDINAL CONTRACTION JOINT SHALL BE ONE THIRD OF THE SLAB THICKNESS.
7. THE TRANSVERSE BAR SPACING SHALL BE 48 IN. FOR ALL THE CONCRETE PAVEMENT WIDTHS.
8. AT LONGITUDINAL CONTRACTION JOINTS, SINGLE PIECE TIE BARS SHALL BE USED. THE TIE BARS SHALL BE PLACED MIDWAY BETWEEN THE TRANSVERSE BARS AT 48 IN. SPACING FOR THE LOWER STEEL MAT ONLY.
9. AT LONGITUDINAL CONSTRUCTION JOINTS, MULTIPLE PIECE TIE BARS SHALL BE PLACED AT 24 IN. SPACING FOR BOTH STEEL MATS. WHEN APPROVED BY THE ENGINEER, SINGLE PIECE TIE BARS MAY BE USED BY INSERTING INTO PLASTIC CONCRETE.
10. WHEN TYING CONCRETE GUTTER AT A LONGITUDINAL JOINT, THE TIE BAR LENGTH OR POSITION MAY BE ADJUSTED. PROVIDE 3 IN. OF CONCRETE COVER FROM THE BACK OF GUTTER TO THE END OF TIE BAR.
11. MISSING OR DAMAGED TIE BARS SHALL BE REPLACED BY DRILLING AND EPOXY GROUTING AT THE CONTRACTOR'S EXPENSE.
12. OMIT TIE BARS LOCATED WITHIN 18 IN. OF THE TRANSVERSE CONSTRUCTION JOINTS. USE HAND-OPERATED IMMERSION VIBRATORS TO CONSOLIDATE THE CONCRETE ADJACENT TO ALL FORMED JOINTS.
13. OBTAIN THE ENGINEER'S WRITTEN APPROVAL, IF THE CONCRETE MIX DESIGN USES MORE THAN 5.5 SACKS/CY.
14. LONGITUDINAL REINFORCING STEEL SPLICES SHALL BE A MINIMUM OF 25 IN.

TABLE NO. 1 LONGITUDINAL STEEL

SLAB THICKNESS AND BAR SIZE		REGULAR STEEL BARS	FIRST SPACING AT EDGE OR JOINT	ADDITIONAL STEEL BARS AT TRANSVERSE CONSTRUCTION JOINT	
T (IN.)	BAR SIZE	SPACING C (IN.)	SPACING d (IN.)	SPACING 2 x c (IN.)	LENGTH L (IN.)
14	#6	9.5	3 TO 4	19	50
15	#6	8.5	3 TO 4	17	50

TABLE NO. 2 TWO LAYER STEEL PLACEMENT SPECIFICATIONS OF DIMENSIONS

THICKNESS T (IN.)	T1 (IN.)	T2 (IN.)
14	4.5	8.0
15	5.0	8.5

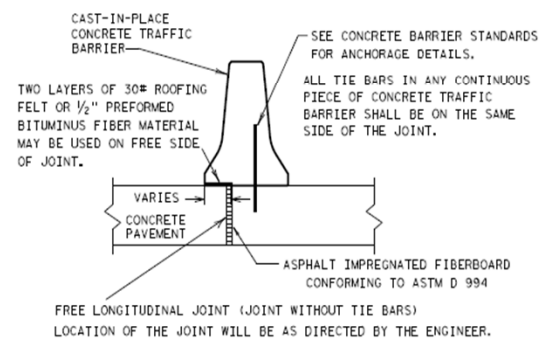

FREE LONGITUDINAL JOINT DETAIL

Texas Department of Transportation
Design Division Standard

CONTINUOUSLY REINFORCED CONCRETE PAVEMENT
TWO LAYER STEEL BAR PLACEMENT
T-14, & 15 INCHES

CRCP (2) - 11

FILED	crp211.dgn	DATE	11/09/2009	BY	LL	CHK	HC	DES
©	TxDOT	NOVEMBER	2009	CONTRACT	NO.	JOB		HIGHWAY
		REVISIONS						
		DIST		COUNTY				SHEET NO.
		10/10/2011	460	04	114			

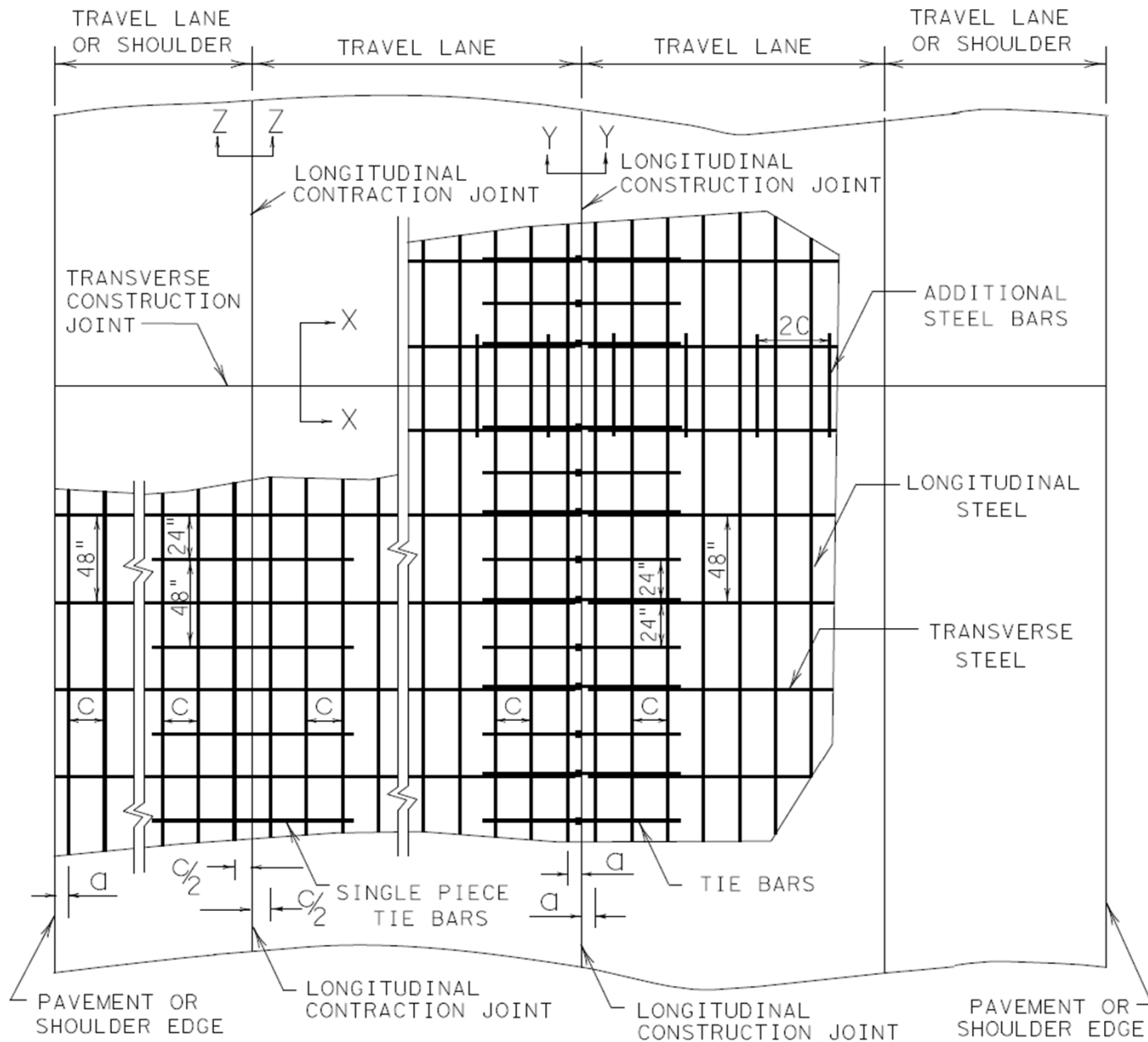

TYPICAL PAVEMENT LAYOUT

PLAN VIEW (NOT TO SCALE)

GENERAL NOTES

4. STEEL BAR PLACEMENT TOLERANCE SHALL BE ± 1 IN. HORIZONTALLY AND ± 0.5 IN. VERTICALLY. CALCULATED AVERAGE BAR SPACING (CONCRETE PLACEMENT WIDTH / NUMBER OF LONGITUDINAL BARS) SHALL CONFORM TO TABLE NO.1 AND AS SPECIFIED.







11.12.2010 11:33



11.12.2010 12:39

GENERAL NOTES

5. PAVEMENT WIDTHS OF MORE THAN 15 FT. SHALL HAVE A LONGITUDINAL JOINT (SECTION Z-Z OR SECTION Y-Y). THESE JOINTS SHALL BE LOCATED WITHIN 6 IN. OF THE LANE LINE UNLESS THE JOINT LOCATION IS SHOWN ELSEWHERE ON THE PLANS.



5. PAVEMENT WIDTHS OF MORE THAN 15 FT. SHALL HAVE A LONGITUDINAL JOINT (SECTION Z-Z OR SECTION Y-Y). THESE JOINTS SHALL BE LOCATED WITHIN 6 IN. OF THE LANE LINE UNLESS THE JOINT LOCATION IS SHOWN ELSEWHERE ON THE PLANS.



GENERAL NOTES

- THE SAW CUT DEPTH FOR THE LONGITUDINAL CONTRACTION JOINT SHALL BE ONE THIRD OF THE SLAB THICKNESS.









GENERAL NOTES

7. WHEN APPROVED BY THE ENGINEER, SINGLE PIECE TIE BARS MAY BE USED BY INSERTING INTO PLASTIC CONCRETE AT LONGITUDINAL CONSTRUCTION JOINTS.



GENERAL NOTES

- MISSING OR DAMAGED TIE BARS SHALL BE REPLACED BY DRILLING AND EPOXY GROUTING AT THE CONTRACTOR'S EXPENSE.









10.27.2011 10:06





11/11/2010 10:31



04.14.2010 13:25

GENERAL NOTES

10. OMIT TIE BARS LOCATED WITHIN 18 IN. OF THE TRANSVERSE CONSTRUCTION JOINTS. USE HAND-OPERATED IMMERSION VIBRATORS TO CONSOLIDATE THE CONCRETE ADJACENT TO ALL FORMED JOINTS.







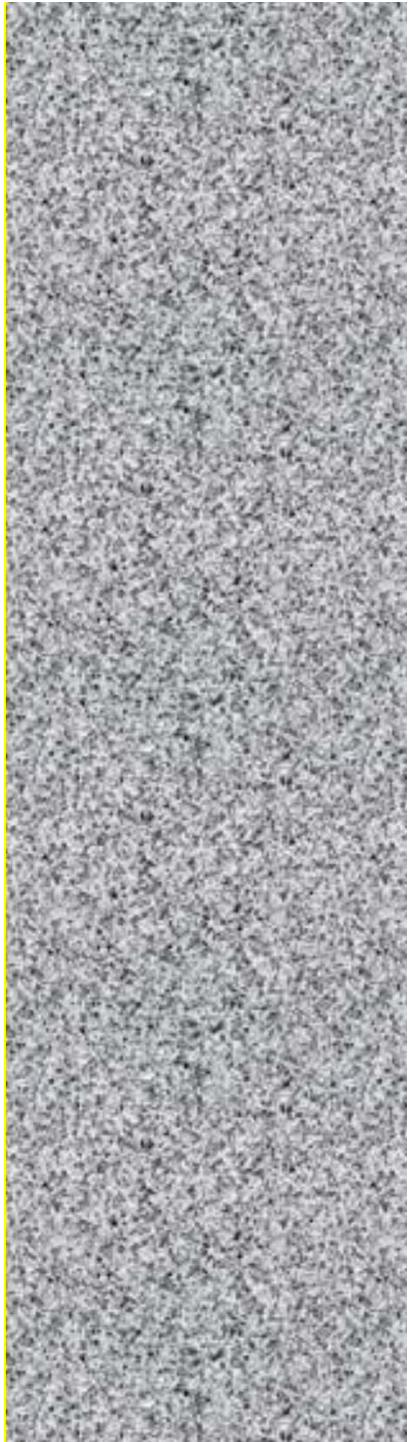

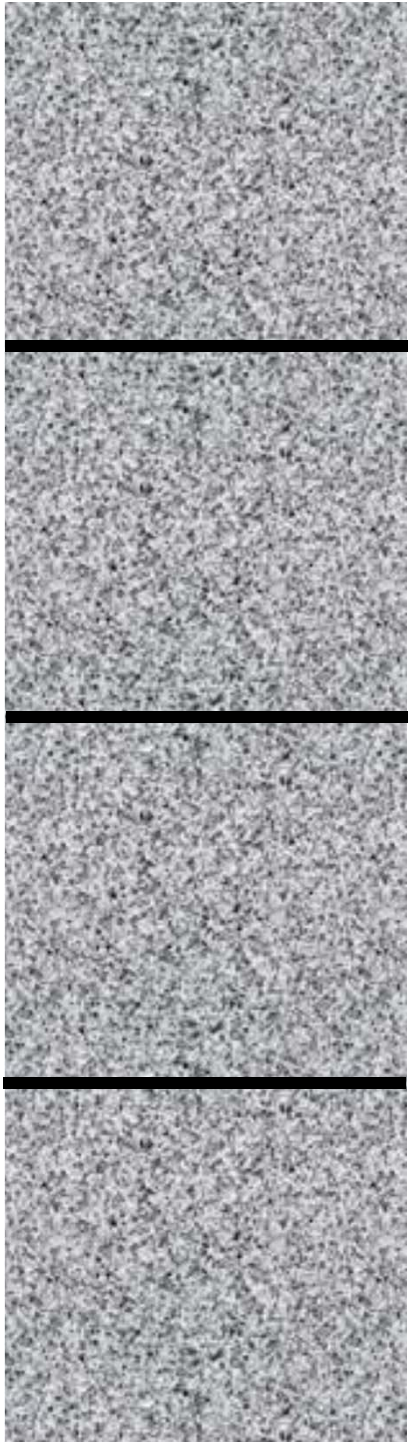

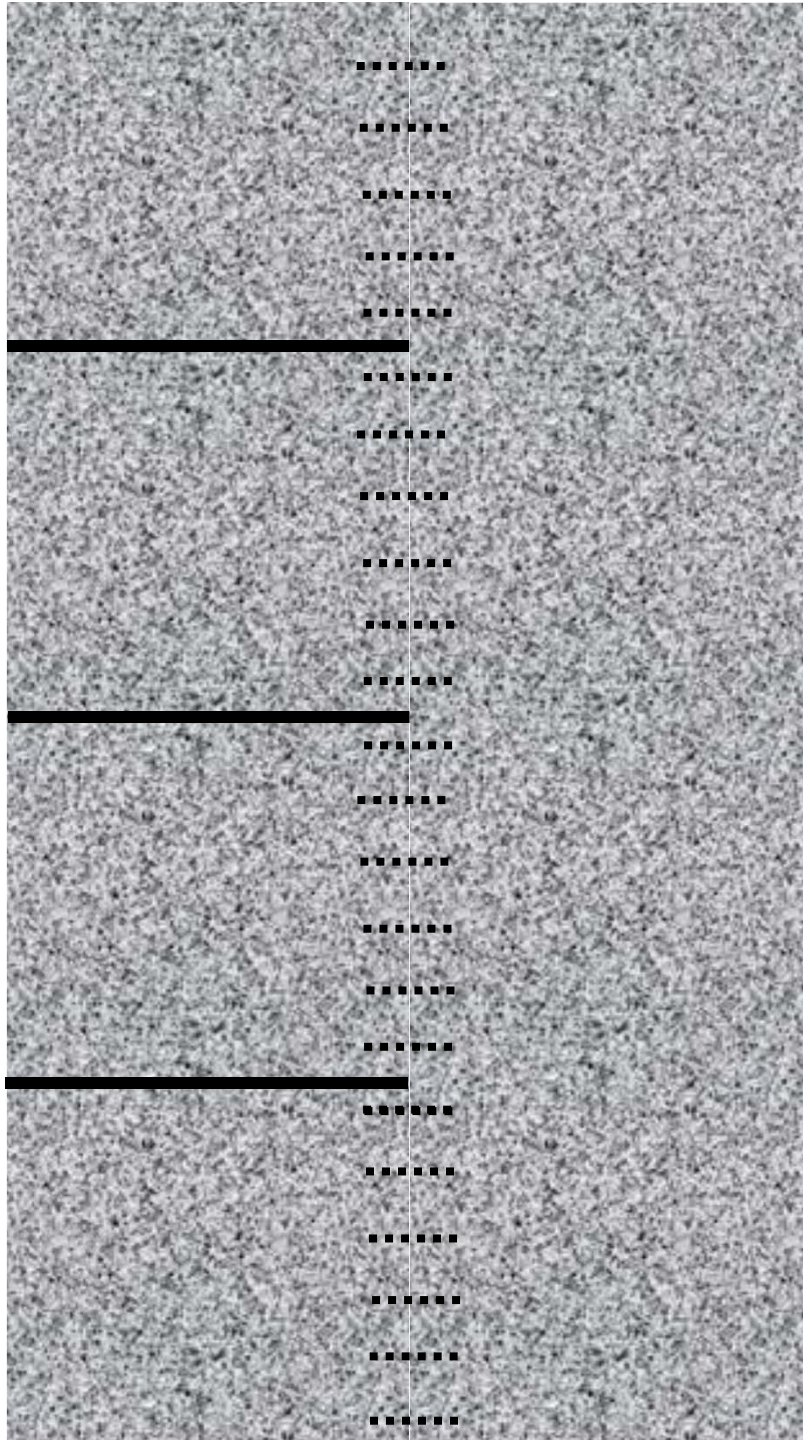

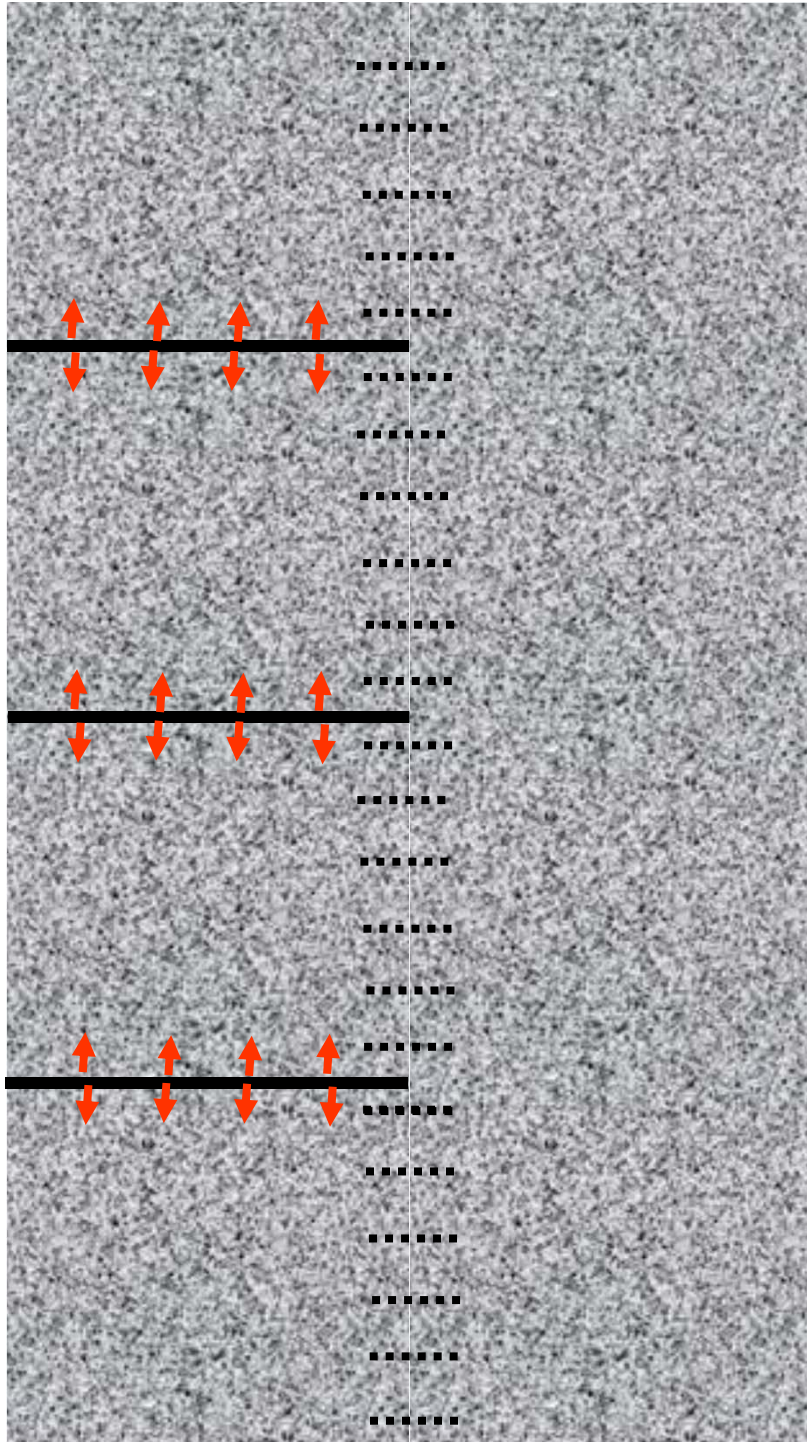

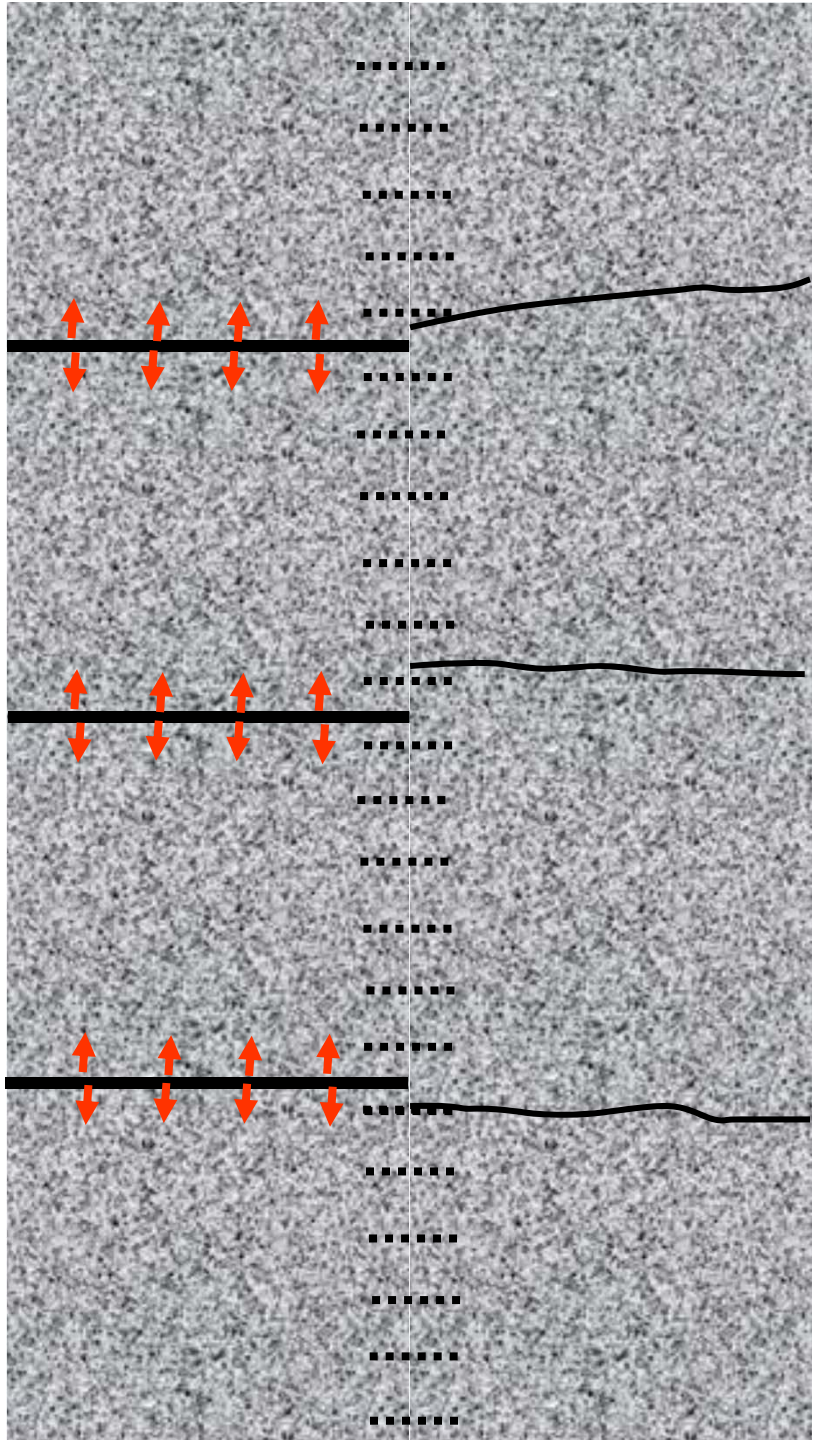

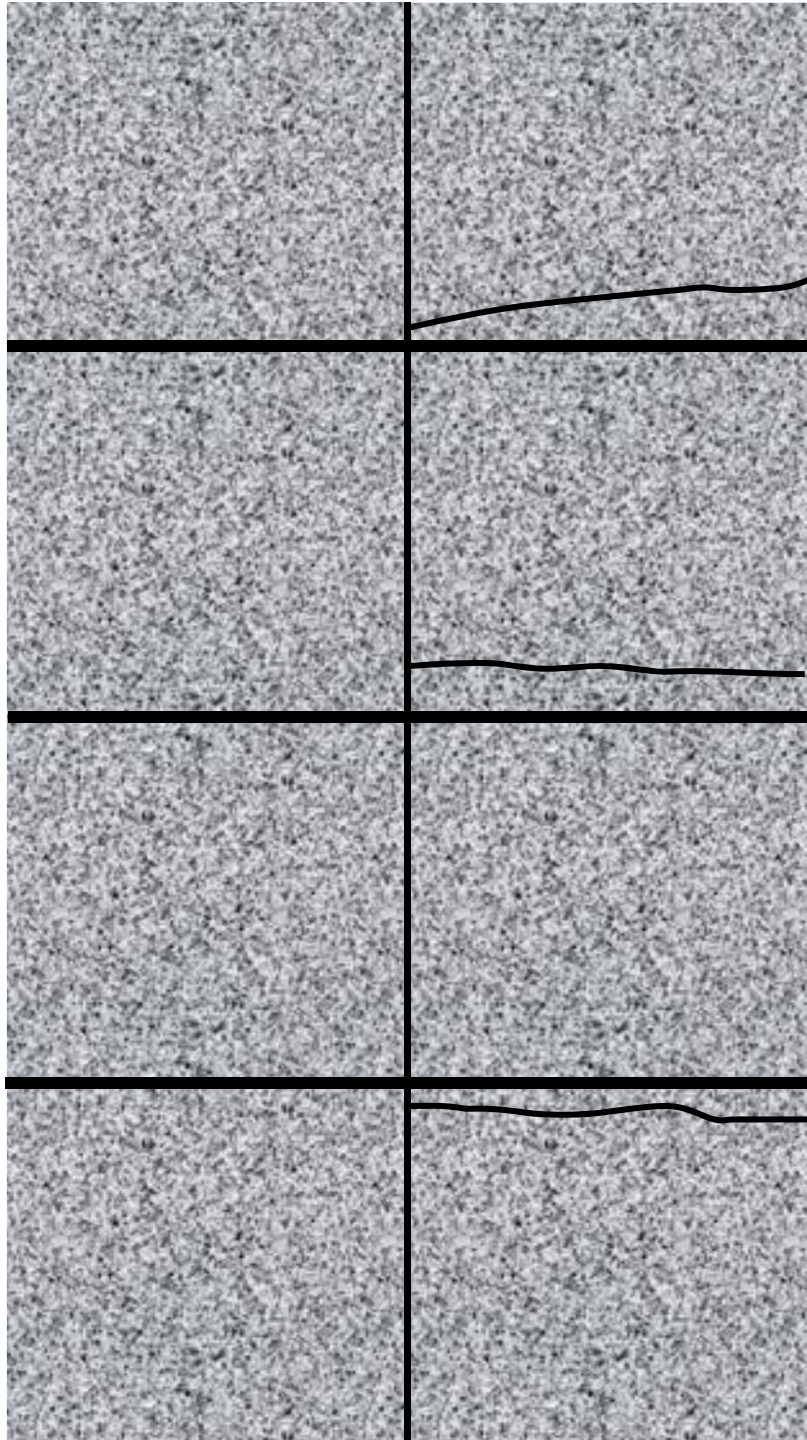





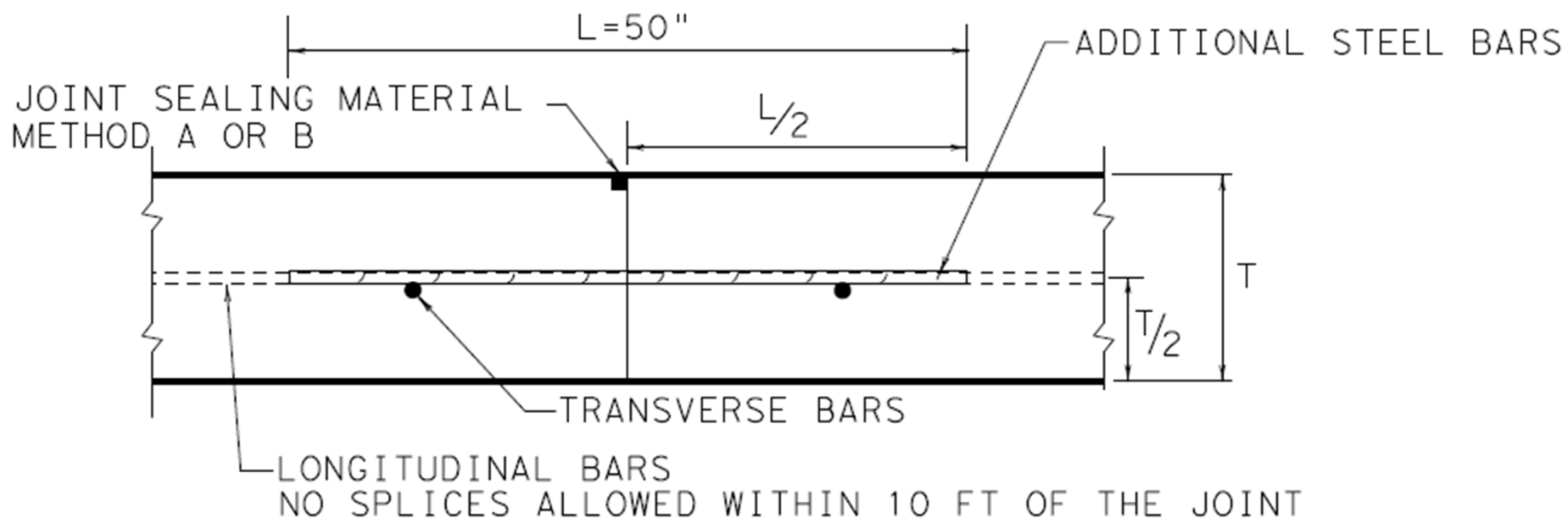

TRANSVERSE CONSTRUCTION JOINT

TABLE NO.1 LONGITUDINAL STEEL (Cont.)					
SLAB THICKNESS AND BAR SIZE		REGULAR STEEL BARS	FIRST SPACING AT EDGE OR JOINT	ADDITIONAL STEEL BARS AT TRANSVERSE CONSTRUCTION JOINT	
T (IN.)	BAR SIZE	SPACING c (IN.)	SPACING d (IN.)	SPACING $2 \times c$ (IN.)	LENGTH L (IN.)
10.0	#6	7.0	3 TO 4	14	50
10.5	#6	6.75	3 TO 4	13.5	50
11.0	#6	6.5	3 TO 4	13	50
11.5	#6	6.25	3 TO 4	12.5	50
12.0	#6	6.0	3 TO 4	12	50
12.5	#6	5.75	3 TO 4	11.5	50
13.0	#6	5.5	3 TO 4	11	50



10.27.2011 10:17

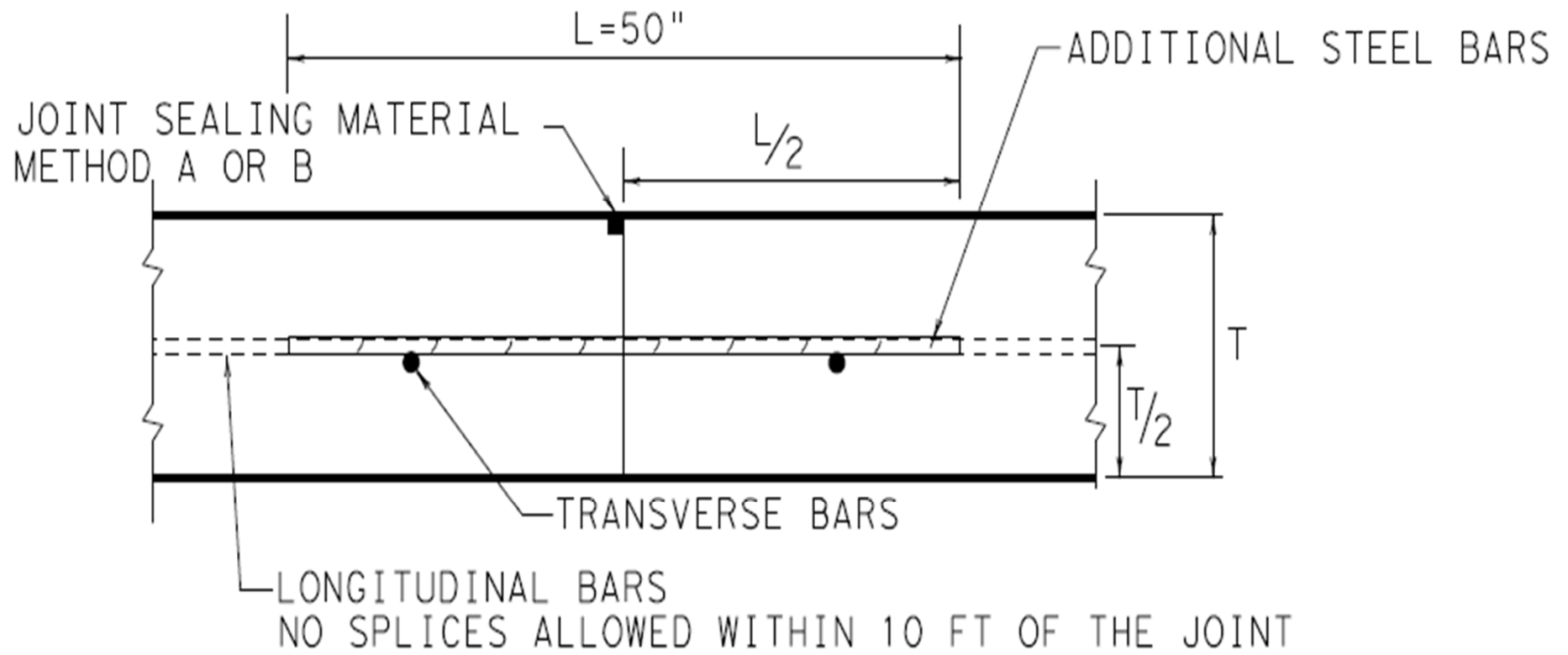

TRANSVERSE CONSTRUCTION JOINT

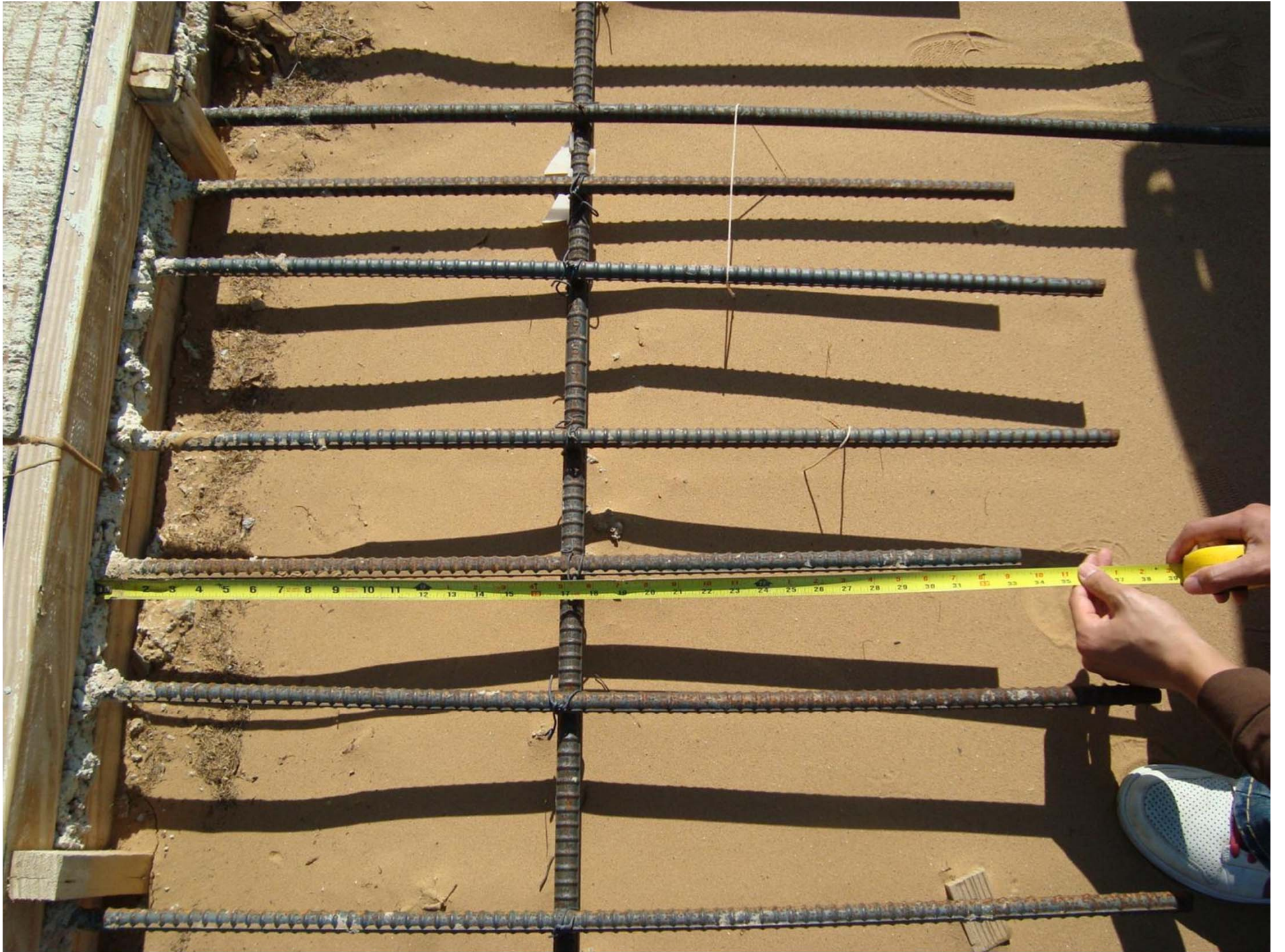



08.08.2011 18:14









ACI 211 Step 2 – Max Aggregate Size

- $1/5$ between the forms
- $1/3$ the depth of slabs
- $3/4$ of min clear spacing between reinforcing bars

Recommendations for Maximum, Nominal Aggregate Size

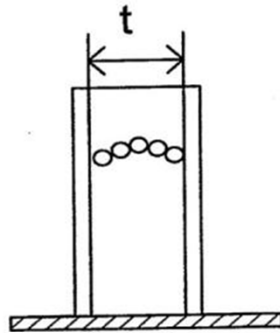

Max nominal aggregate size = $1/5$ the minimum dimension between formed surfaces

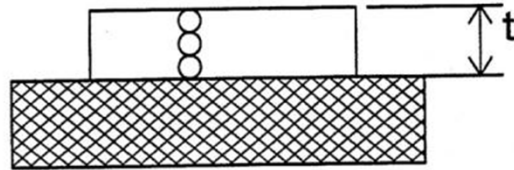

Max nominal aggregate size = $1/3$ the minimum thickness of slabs

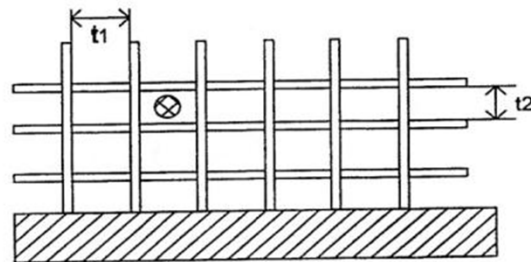

Max nominal aggregate size = 0.75 the minimum clear spacing between reinforcing bars.

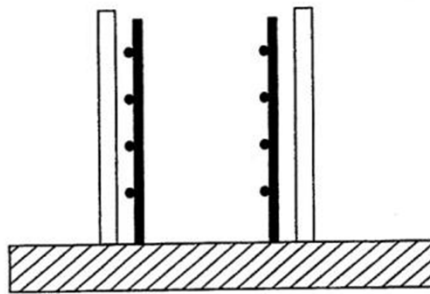

Max nominal aggregate size = 0.75 the minimum clear cover between rebar and forms. Note that this is most important when the appearance of the finished surface is critical. Note also that the clear cover to the horizontal bars is likewise the most important value when applying this rule.





08.08.2011 18:14







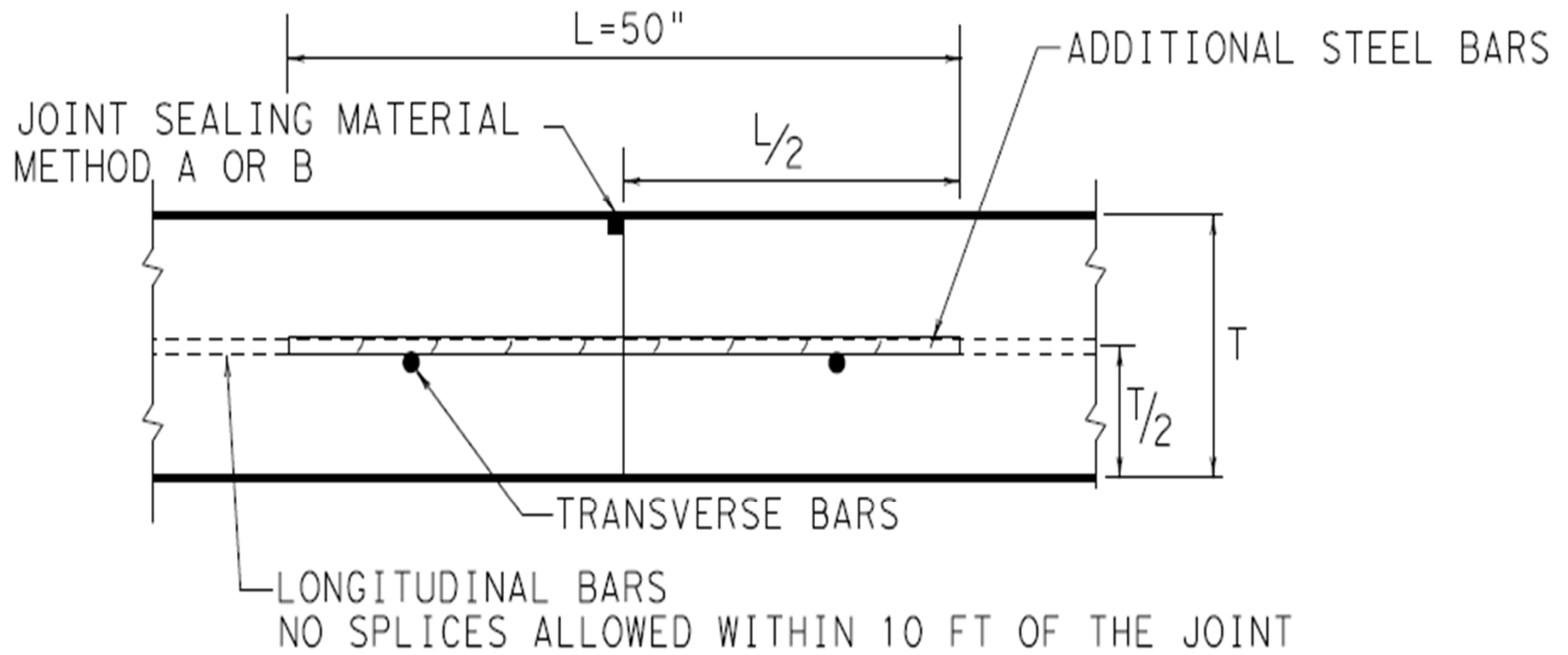

TRANSVERSE CONSTRUCTION JOINT



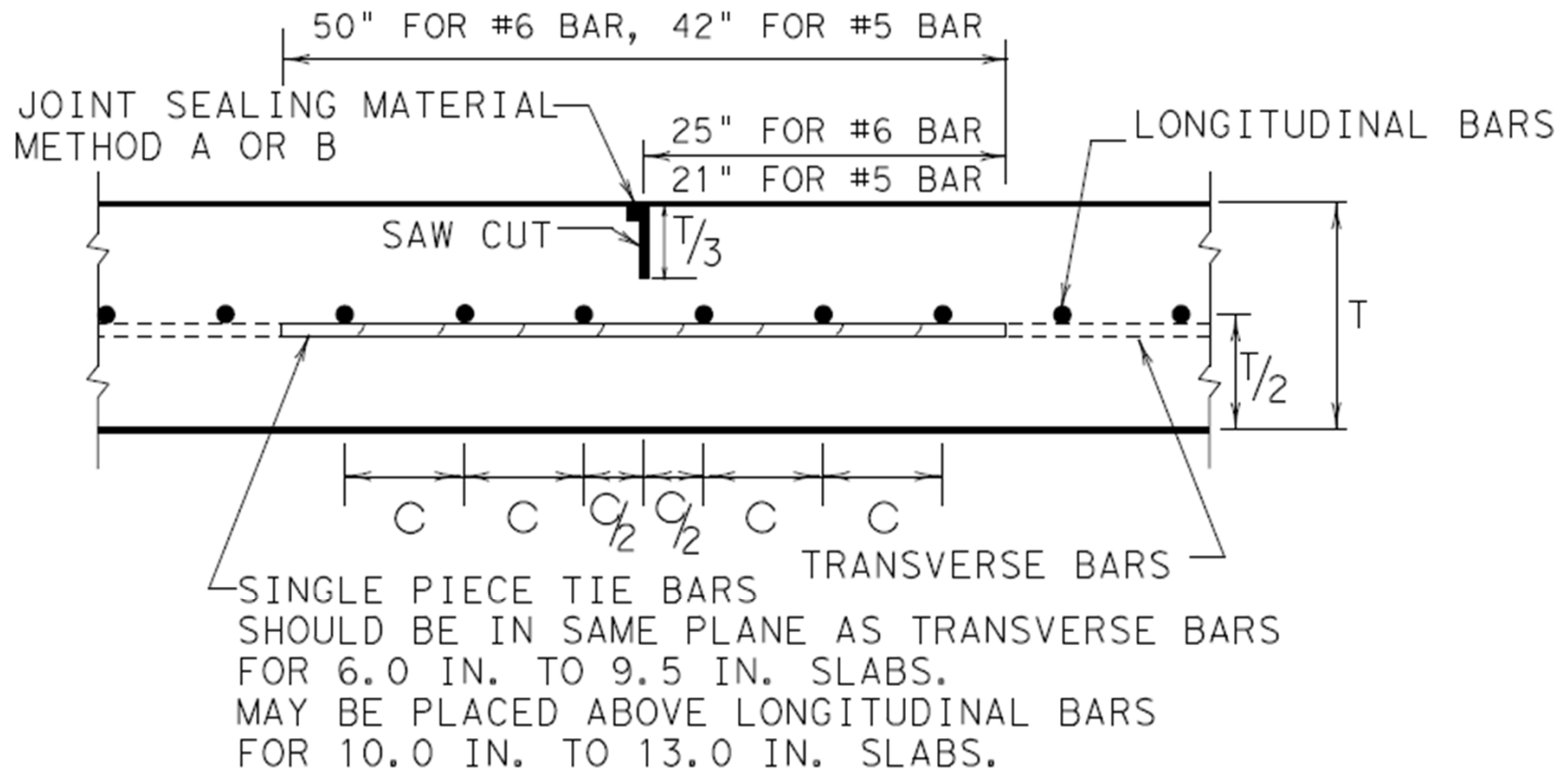

LONGITUDINAL CONTRACTION JOINT







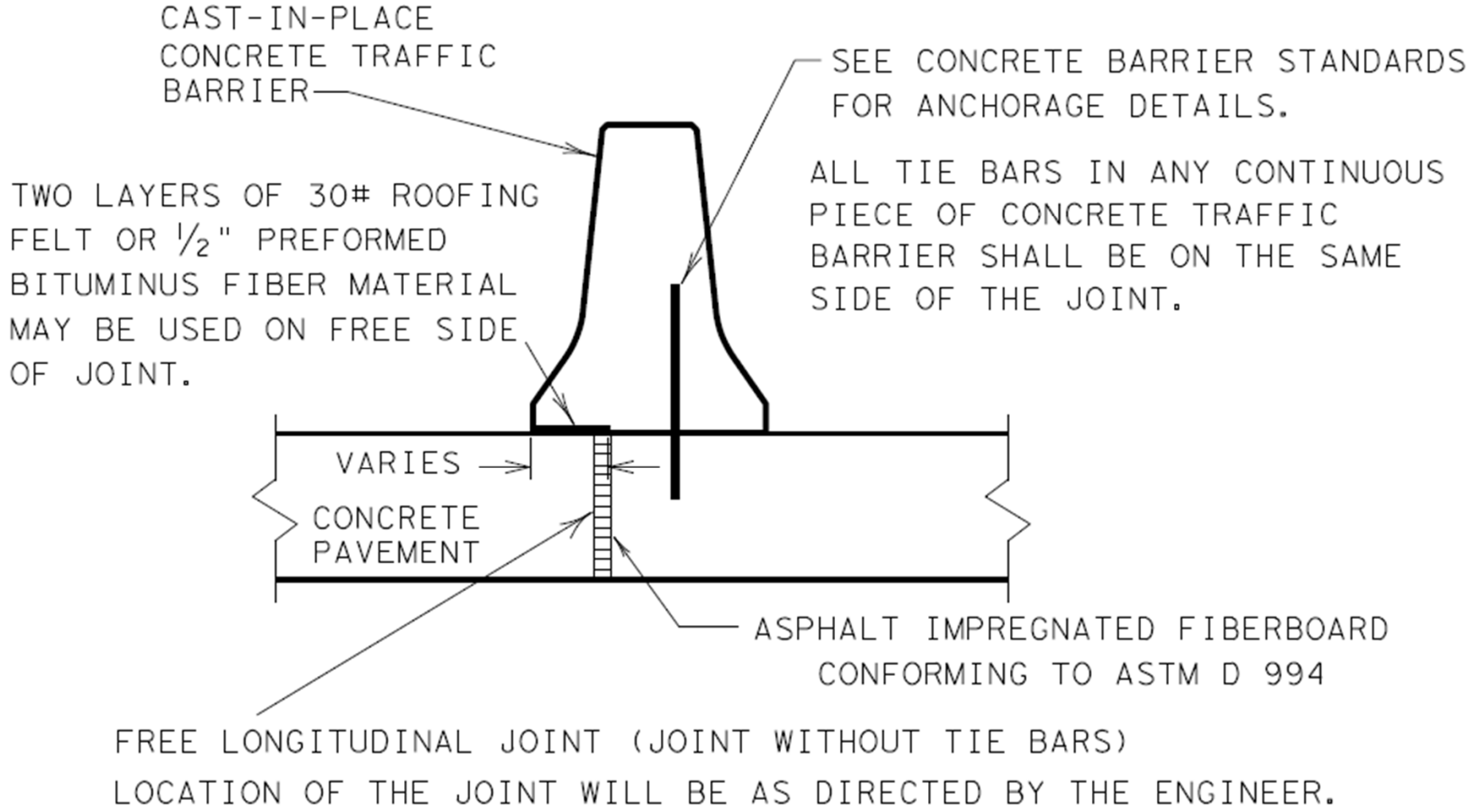

FREE LONGITUDINAL JOINT DETAIL

End of Design Module

CRCP Construction/Materials Module

- A. Paving and Quality Control Plan.** Submit a paving and quality control plan for approval before beginning pavement construction operations. Include details of all operations in the concrete paving process, including longitudinal construction joint layout, sequencing, curing, lighting, early opening, leave-outs, sawing, inspection, testing, construction methods, other details and description of all equipment. List certified personnel performing the testing. Submit revisions to the paving and quality control plan for approval.

360.2. Materials.

- A. Hydraulic Cement Concrete.** Provide hydraulic cement concrete in accordance with Item 421, "Hydraulic Cement Concrete," except that strength over-design is not required. Provide Class P concrete designed to meet a minimum average flexural strength of 570 psi or a minimum average compressive strength of 3,500 psi at 7 days or a minimum average flexural strength of 680 psi or a minimum average compressive strength of 4,400 psi at 28 days. Test in accordance with Tex-448-A or Tex-418-A.

When shown on the plans or allowed, provide Class HES concrete for very early opening of small pavement areas or leave-outs to traffic. Design Class HES to meet the requirements of Class P and a minimum average flexural strength of 400 psi or a minimum average compressive strength of 2,600 psi in 24 hr., unless other early strength and time requirements are shown on the plans or allowed. No strength over-design is required. Type III cement is allowed for Class HES concrete.

Provide mechanically operated vibratory equipment capable of adequately consolidating the concrete. Provide immersion vibrators on the paving equipment at sufficiently close intervals to provide uniform vibration and consolidation of the concrete over the entire width and depth of the pavement and in accordance with the manufacturer's recommendations. Provide immersion vibrator units that operate at a frequency in air of at least 8,000 cycles per minute. Provide enough hand-operated immersion vibrators for timely and proper consolidation of the concrete along forms, at joints and in areas not covered by other vibratory equipment. Surface vibrators may be used to supplement equipment-mounted immersion vibrators. Provide tachometers to verify the proper operation of all vibrators.

E. Curing Equipment. Provide a self-propelled machine for applying membrane curing compound using mechanically pressurized spraying equipment with atomizing nozzles. Provide equipment and controls that maintain the required uniform rate of application over the entire paving area. Provide curing equipment that is independent of all other equipment when production rates are such that the first application of membrane curing compound cannot be accomplished immediately after texturing and after free moisture has disappeared. Hand-operated pressurized spraying equipment with atomizing nozzles may only be used on small or irregular areas or, when permitted, in emergencies due to equipment breakdown.

When job-control testing by the Contractor is waived by the plans, the Engineer will perform the testing; however, this does not waive the Contractor's responsibility for providing materials and work in accordance with this Item.

- 1. Job-Control Strength.** Unless otherwise shown on the plans or permitted by the Engineer, use 7-day job-control concrete strength testing in accordance with Tex-448-A or Tex-418-A.

For 7-day job-control by flexural strength, use a flexural strength of 520 psi or a lower job-control strength value proven to meet a 28-day flexural strength of 680 psi as correlated in accordance with Tex-427-A. For 7-day job-control by compressive strength, use a compressive strength of 3,200 psi or a lower job-control strength value proven to meet a 28-day compressive strength of 4,400 psi as correlated in accordance with Tex-427-A.

Job control of concrete strength may be correlated to an age other than 7 days in accordance with Tex-427-A when approved. Job-control strength of Class HES concrete is based on the required strength and time.

When a job-control concrete strength test value is more than 10% below the required job-control strength or when 3 consecutive job-control strength values fall below the required job-control strength, investigate the strength test procedures, the quality of materials, the concrete production operations, and other possible problem areas to determine the cause. Take necessary action to correct the problem, including redesign of the concrete mix if needed. The Engineer may suspend concrete paving if the Contractor is unable to identify, document, and correct the cause of low strength test values in a timely manner. If any job-control strength is more than 15% below the required job-control strength, the Engineer will evaluate the structural adequacy of the pavements. When directed, remove and replace pavements found to be structurally inadequate at no additional cost.





421.2.2 Fine Aggregate:.....Unless otherwise shown on the plans, provide fine aggregate with a sand equivalent of at least 80 in accordance with Tex-203-F.

C. Reinforcing Steel and Joint Assemblies. Accurately place and secure in position all reinforcing steel as shown on the plans. Place dowels at mid-depth of the pavement slab, parallel to the surface. Place dowels for transverse contraction joints parallel to the pavement edge.





08.08.2011 18:39

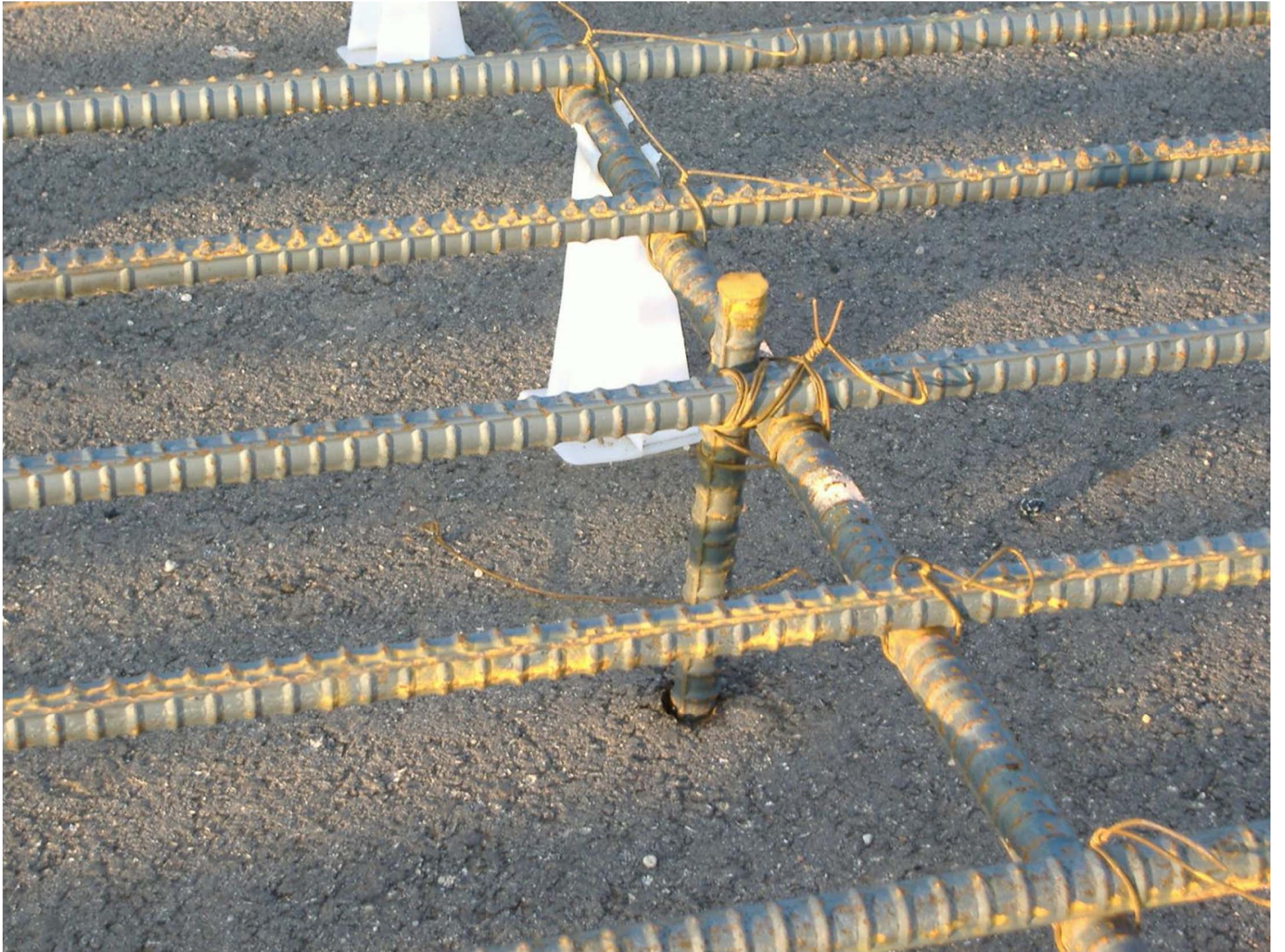



JUL 30 2008



JUL 30 2008

Stagger the longitudinal reinforcement splices to avoid having more than 1/3 of the splices within a 2-ft. longitudinal length of each lane of the pavement.





Use multiple-piece tie bars or drill and epoxy grout tie bars at longitudinal construction joints. Verify that tie bars that are drilled and epoxied into concrete at longitudinal construction joints develop a pullout resistance equal to a minimum of 3/4 of the yield strength of the steel after 7 days.

361.3. Construction.

tiebars as shown on the plans. Epoxy-grout all tiebars for at least a 12-in. embedment into existing concrete. Completely fill the tiebar hole with Type III, Class A or Class C epoxy before inserting the tiebar into the hole.





361.3. Construction.

Provide grout retention disks for all tiebar holes.





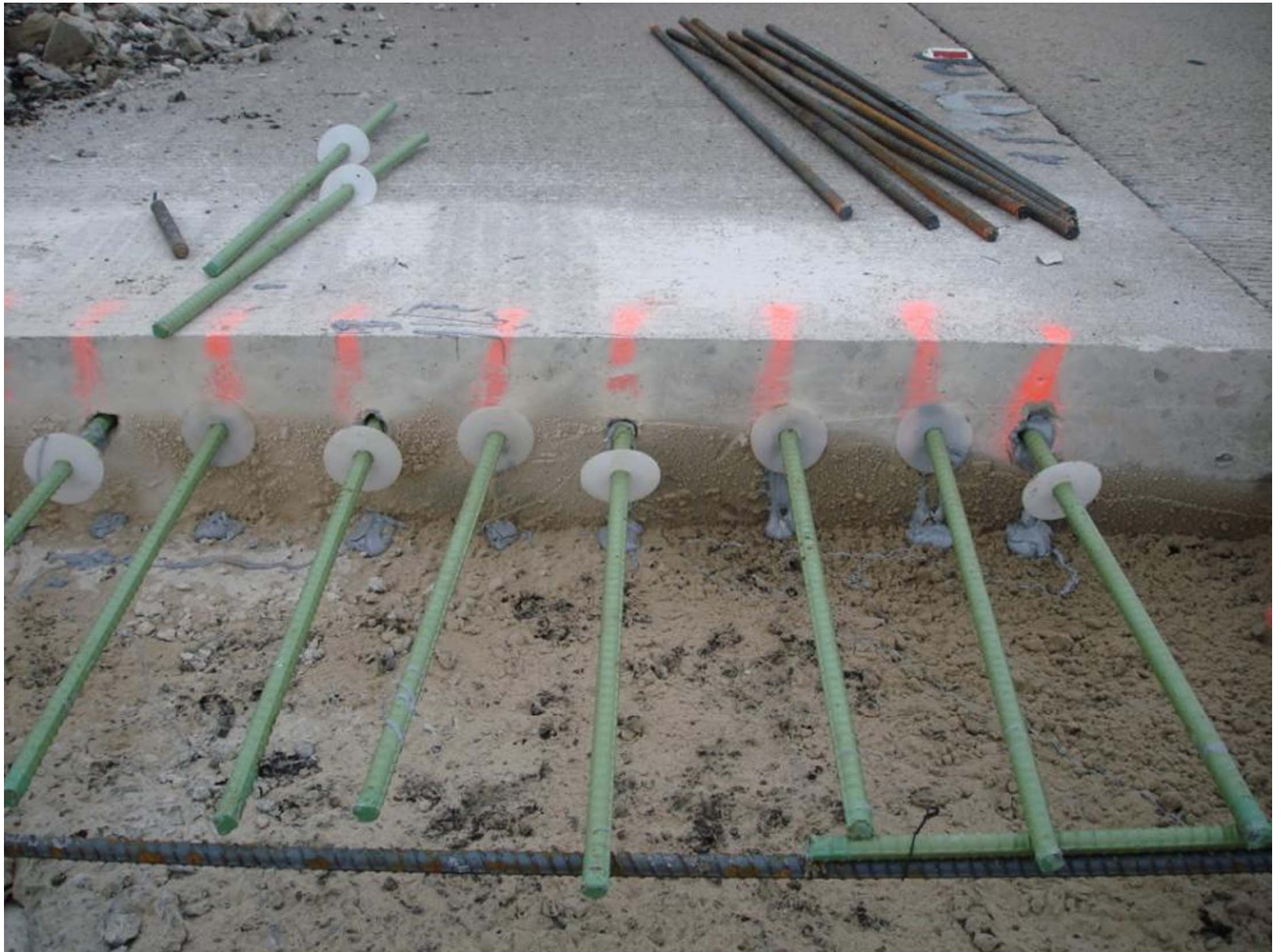















Drill a hole



Clean the hole



Clean the hole



Remove stain on a rebar

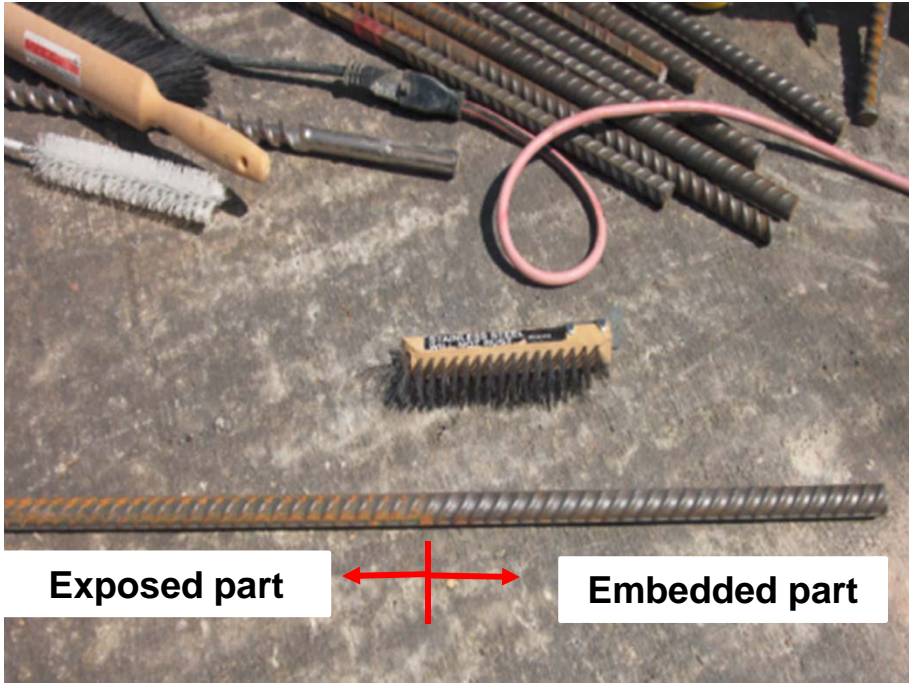



Insert a rebar in the hole



Prevent the epoxy leak



Steel plate

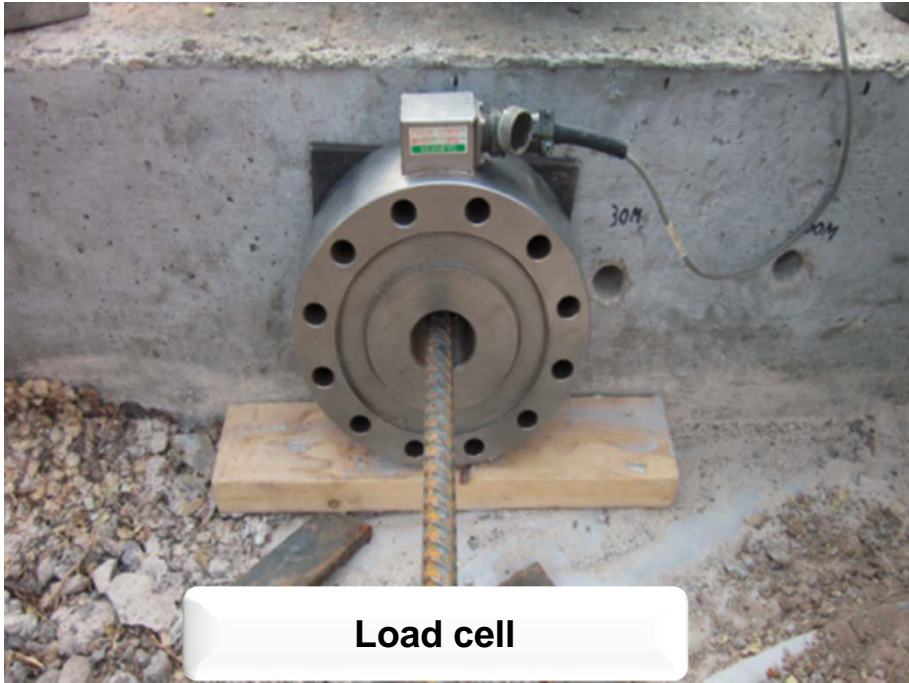

Load cell



Hydraulic jack



Gripper and reference point



LVDT 1



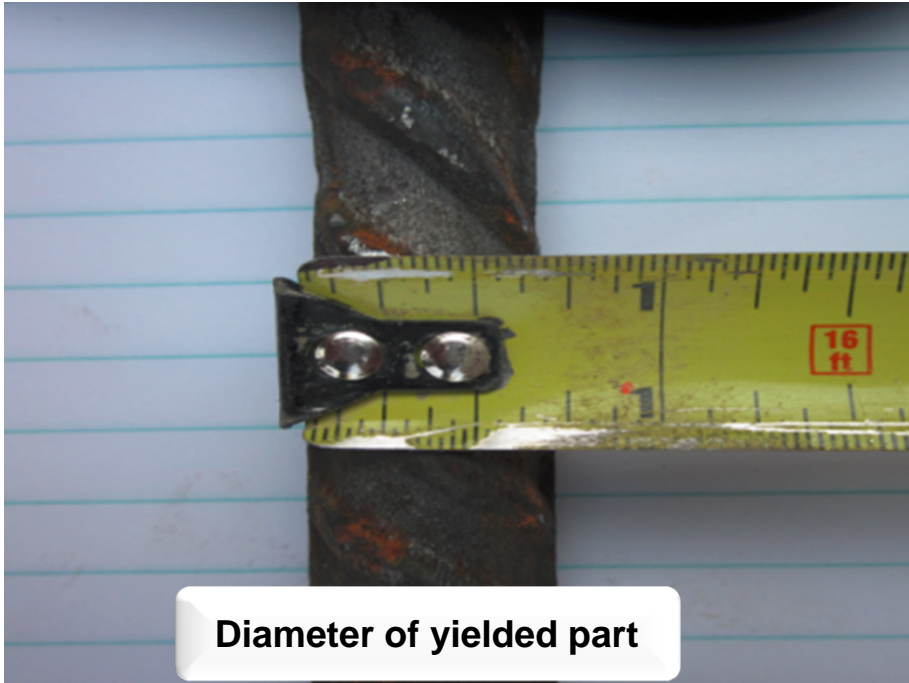

Diameter of yielded part



The Location of yielded part



Failure shape of test 1

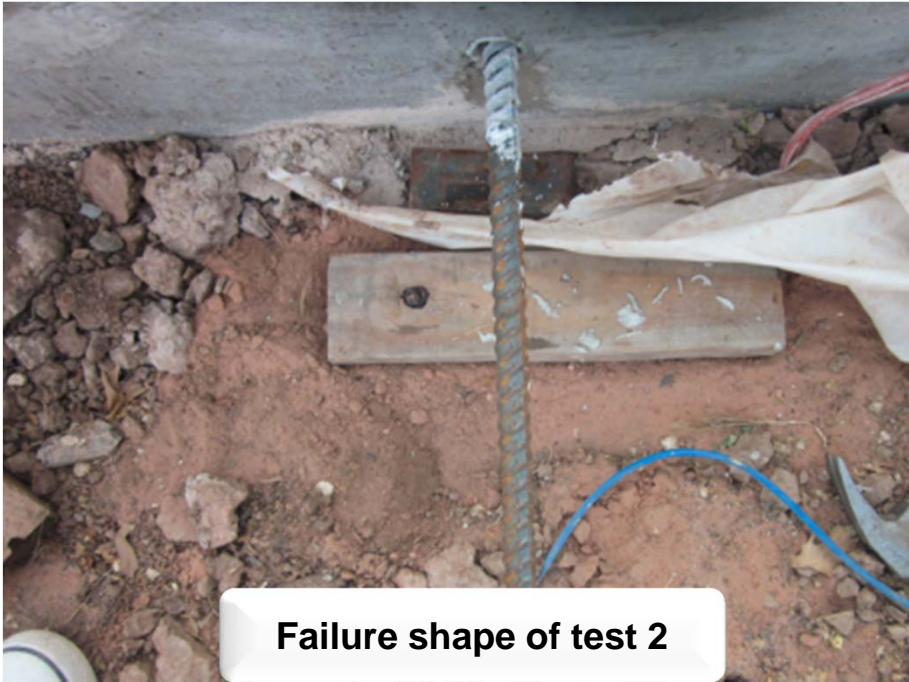

Failure shape of test 2

Test 1

- 1 Hour Curing
- Sufficient Epoxy



Test 2

- 1 Hour Curing
- Deficient Epoxy



Load vs. Displacement

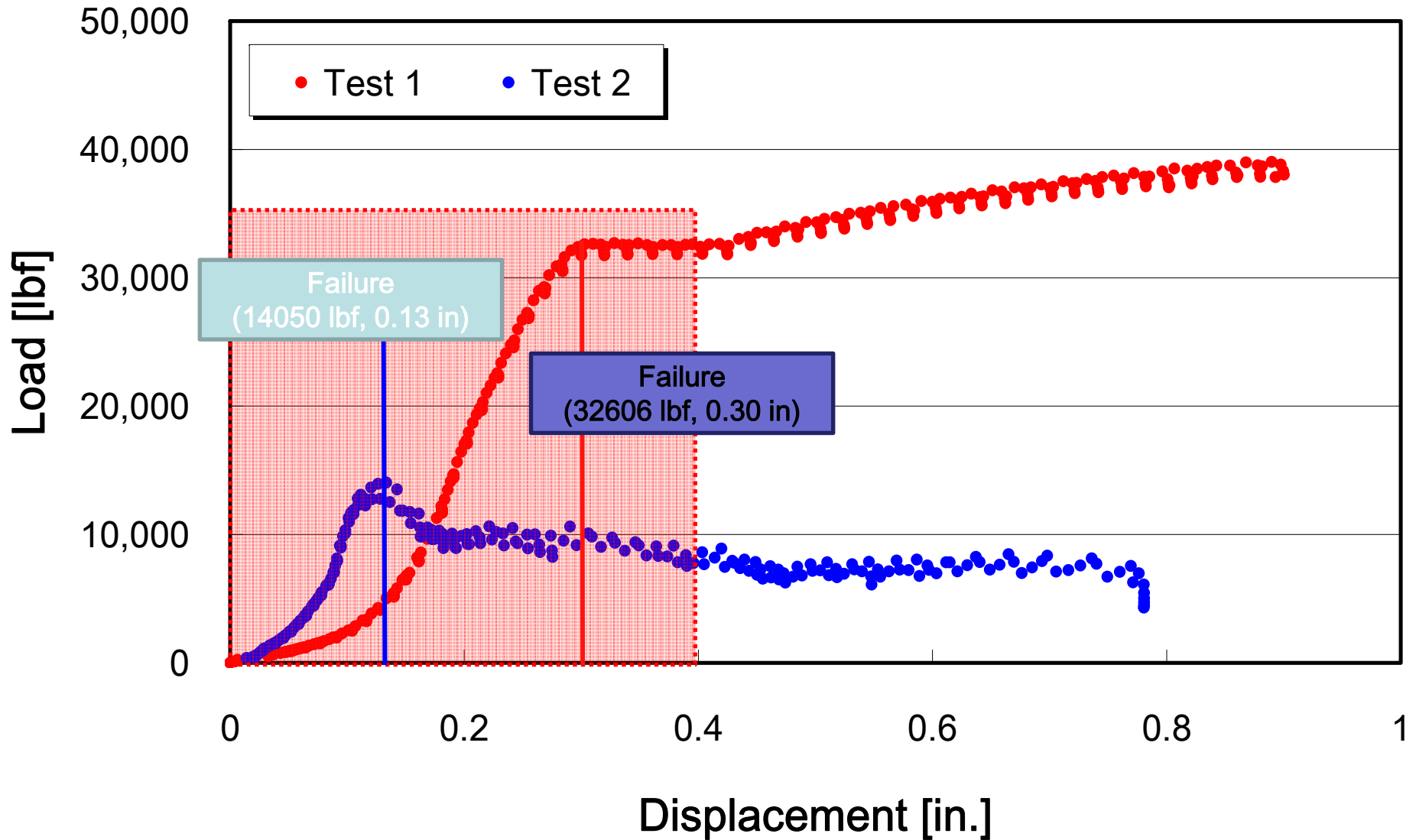

1. **Manual Placement.** Secure reinforcing bars at alternate intersections with wire ties or locking support chairs. Tie all splices with wire.
2. **Mechanical Placement.** If mechanical placement of reinforcement results in steel misalignment or improper location, poor concrete consolidation, or other inadequacies, complete the work using manual methods.

2. Transverse Construction Joints.

a. Continuously Reinforced Concrete Pavement (CRCP).

Install additional longitudinal reinforcement through the bulkhead when shown on the plans. Protect the reinforcing steel immediately beyond the construction joint from damage, vibration, and impact.



- b. Concrete Pavement Contraction Design (CPCD).** When the placing of concrete is intentionally stopped, install and rigidly secure a complete joint assembly and bulkhead in the planned transverse contraction joint location. When the placing of concrete is unintentionally stopped, install a transverse construction joint either at a planned transverse contraction joint location or mid-slab between planned transverse contraction joints. For mid-slab construction joints, install tie bars of the size and spacing used in the longitudinal joints.

F. Concrete Delivery. Clean delivery equipment as necessary to prevent accumulation of old concrete before loading fresh concrete. Use agitated delivery equipment for concrete designed to have a slump of more than 5 in. Segregated concrete is subject to rejection. Place agitated concrete within 60 min. after batching. Place non-agitated concrete within 45 min. after batching. In hot weather or under conditions causing quick setting of the concrete, times may be reduced by the Engineer. Time limitations may be extended if the Contractor can demonstrate that the concrete can be properly placed, consolidated, and finished without the use of additional water.

G. Concrete Placement. Do not allow the pavement edge to deviate from the established paving line by more than 1/2 in. at any point. Place the concrete as near as possible to its final location, and minimize segregation and rehandling. Where hand spreading is necessary, distribute concrete using shovels. Do not use rakes or vibrators to distribute concrete.



- 1. Pavement.** Consolidate all concrete by approved mechanical vibrators operated on the front of the paving equipment. Use immersion-type vibrators that simultaneously consolidate the full width of the placement when machine finishing. Keep vibrators from dislodging reinforcement.

- 2. Date Imprinting.** Imprint dates in the fresh concrete indicating the date of the concrete placement. Make impressions approximately 1 ft. from the outside longitudinal construction joint or edge of pavement and approximately 1 ft. from the transverse construction joint at the beginning of the placement day. Orient the impressions to be read from the outside shoulder in the direction of final traffic. Impress date in DD-MM-YY format. Imprinting of the Contractor name or logo in similar size characters to the date is allowed.

25-06-08

05.04.2010 12:31

- 4. Temperature Restrictions.** Place concrete that is between 40°F and 95°F when measured in accordance with Tex-422-A at the time of discharge, except that concrete may be used if it was already in transit when the temperature was found to exceed the allowable maximum. Take immediate corrective action or cease concrete production when the concrete temperature exceeds 95°F.

Do not place concrete when the ambient temperature in the shade is below 40°F and falling unless approved. Concrete may be placed when the ambient temperature in the shade is above 35°F and rising or above 40°F. When temperatures warrant protection against freezing, protect the pavement with an approved insulating material capable of protecting the concrete for the specified curing period. Submit for approval proposed measures to protect the concrete from anticipated freezing weather for the first 72 hr. after placement. Repair or replace all concrete damaged by freezing.

H. Spreading and Finishing. Finish all concrete pavement with approved self-propelled equipment. Use power-driven spreaders, power-driven vibrators, power-driven strike-off, and screed, or approved alternate equipment. Use the transverse finishing equipment to compact and strike off the concrete to the required section and grade without surface voids. Use float equipment for final finishing. Use concrete with a consistency that allows completion of all finishing operations without addition of water to the surface. Use the minimal amount of water fog mist necessary to maintain a moist surface. Reduce fogging if float or straightedge operations result in excess slurry.











- 1. Finished Surface.** Perform sufficient checks with long-handled 10-ft. and 15-ft. straightedges on the plastic concrete to ensure that the final surface is within the tolerances specified in Surface Test A in Item 585, “Ride Quality for Pavement Surfaces.” Check with the straightedge parallel to the centerline.

2. Maintenance of Surface Moisture. Prevent surface drying of the pavement before application of the curing system. Accomplish this by fog applications of evaporation retardant on the pavement surface. Apply evaporation retardant at the rate recommended by the manufacturer. Reapply the evaporation retardant as needed to maintain the concrete surface in a moist condition until curing system is applied. Do not use evaporation retardant as a finishing aid. Failure to take acceptable precautions to prevent surface drying of the pavement will be cause for shut down of pavement operations.

I. Curing. Keep the concrete pavement surface from drying by water fogging until the curing material has been applied. Maintain and promptly repair damage to curing materials on exposed surfaces of concrete pavement continuously for at least 3 curing days. A curing day is defined as a 24-hr. period when either the temperature taken in the shade away from artificial heat is above 50°F for at least 19 hr. or when the surface temperature of the concrete is maintained above 40°F for 24 hr. Curing begins when the concrete curing system has been applied. Stop concrete paving if curing compound is not being applied promptly and maintained adequately. Other methods of curing in accordance with Item 420, “Concrete Structures,” may be used when specified or approved.

- 1. Membrane Curing.** After texturing and immediately after the free surface moisture has disappeared, spray the concrete surface uniformly with 2 coats of membrane curing compound at an individual application rate of not more than 180 sq. ft. per gallon. Apply the first coat within 10 min. after completing texturing operations. Apply the second coat within 30 min. after completing texturing operations.













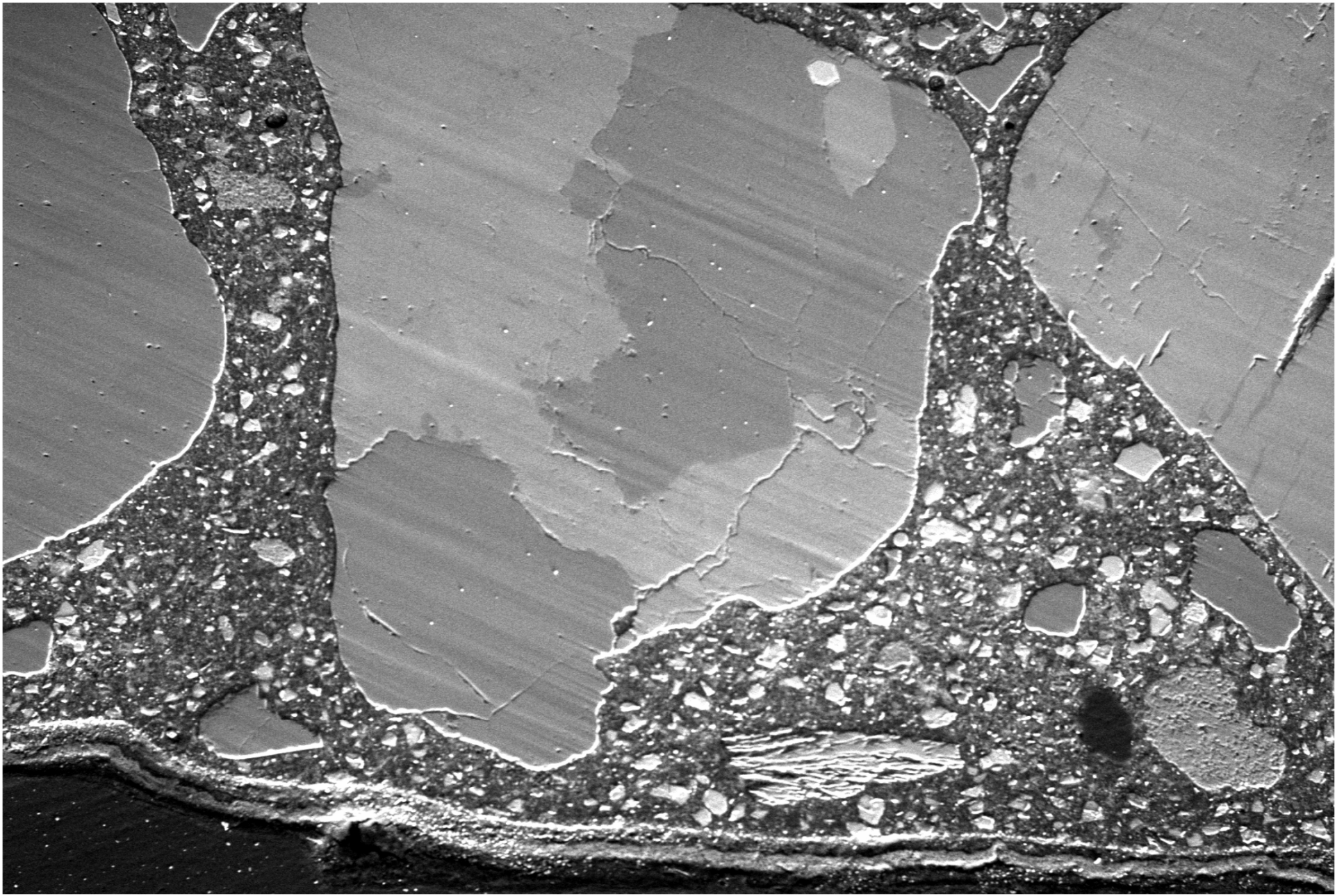

300 μ m

Electron Image 1

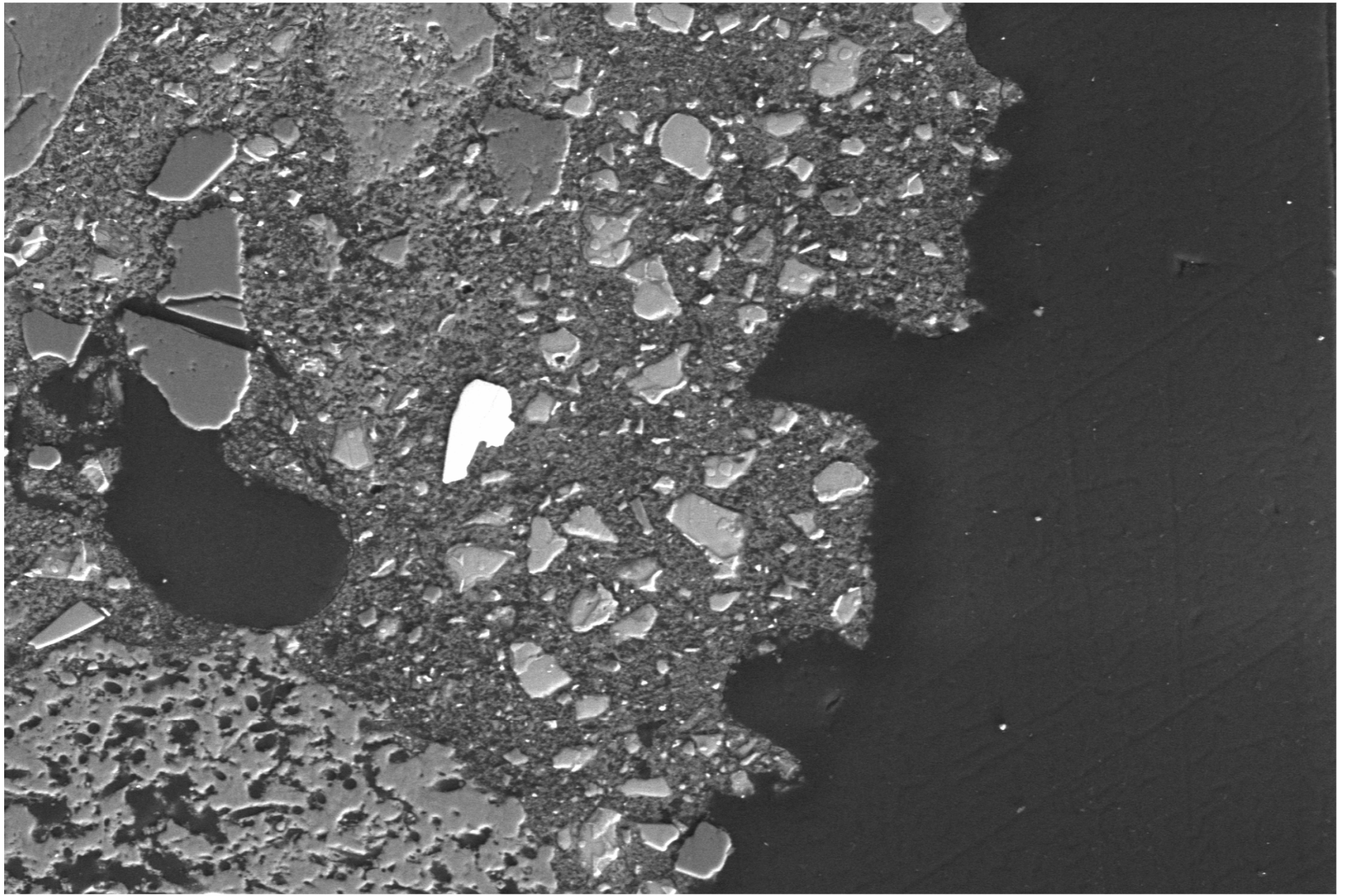

300µm

Electron Image 1







Curing Compound Application

When to apply?

- Depends on **bleeding and evaporation**.
- 2004 Spec: “After texturing and immediately after the free surface moisture has disappeared, spray the concrete surface with 2 coats of membrane curing compound. Apply the first coat within 10 min after completing texturing operations. Apply the second coat within 30 min after completing texturing operations.



Cumulative Bleeding Rate of Paving Concrete

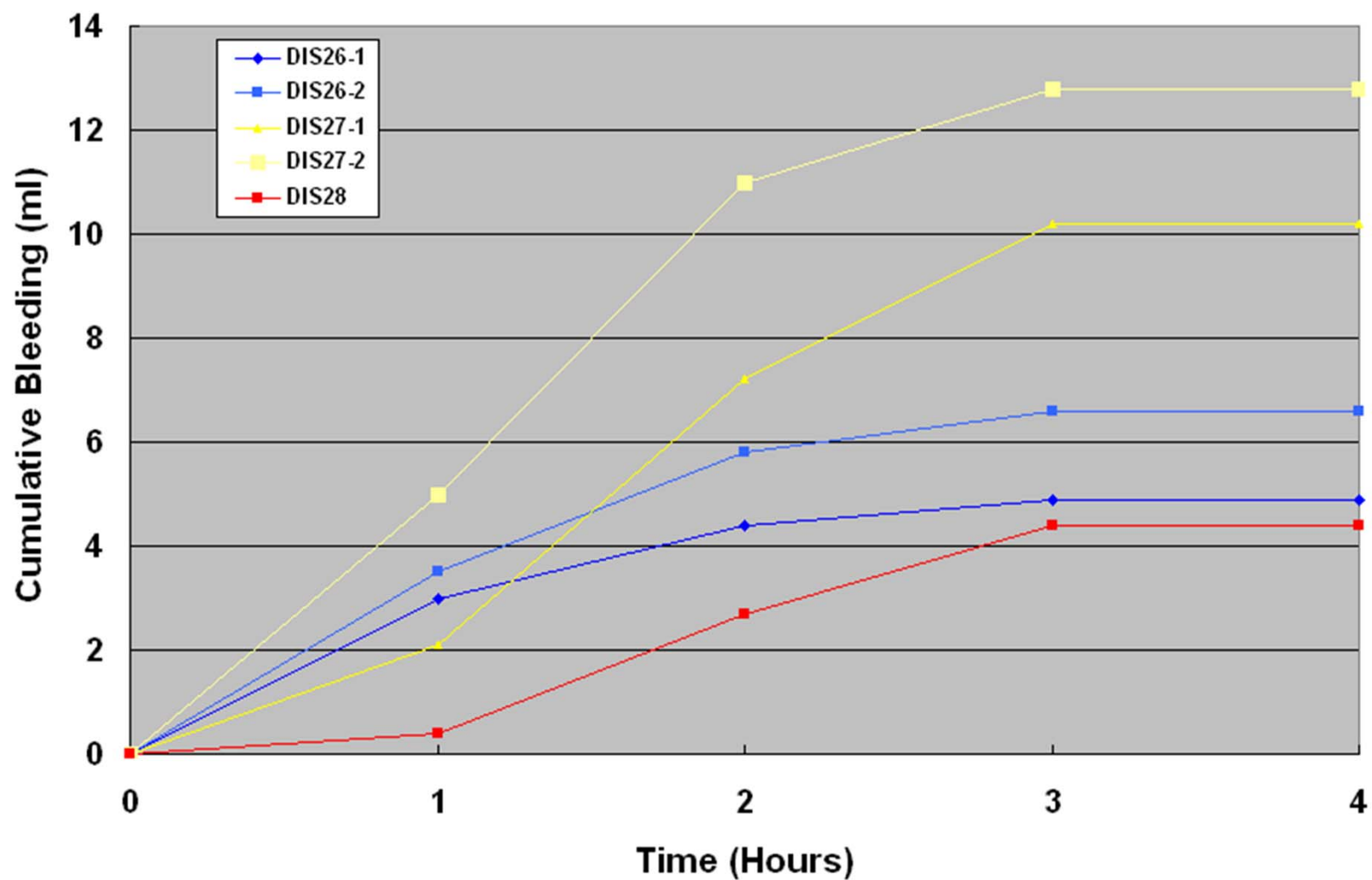

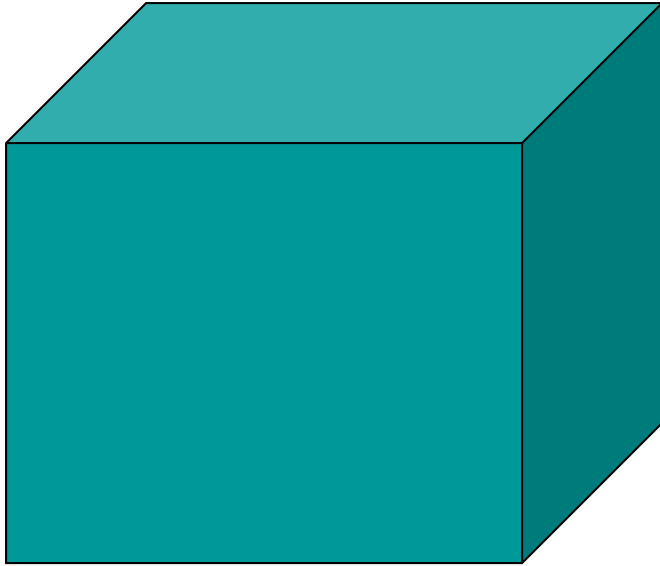

1 cubic inch

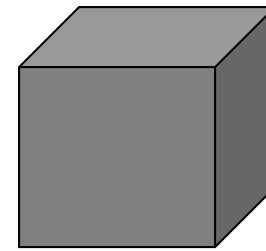

1 ml

1 cubic inch = 16 ml

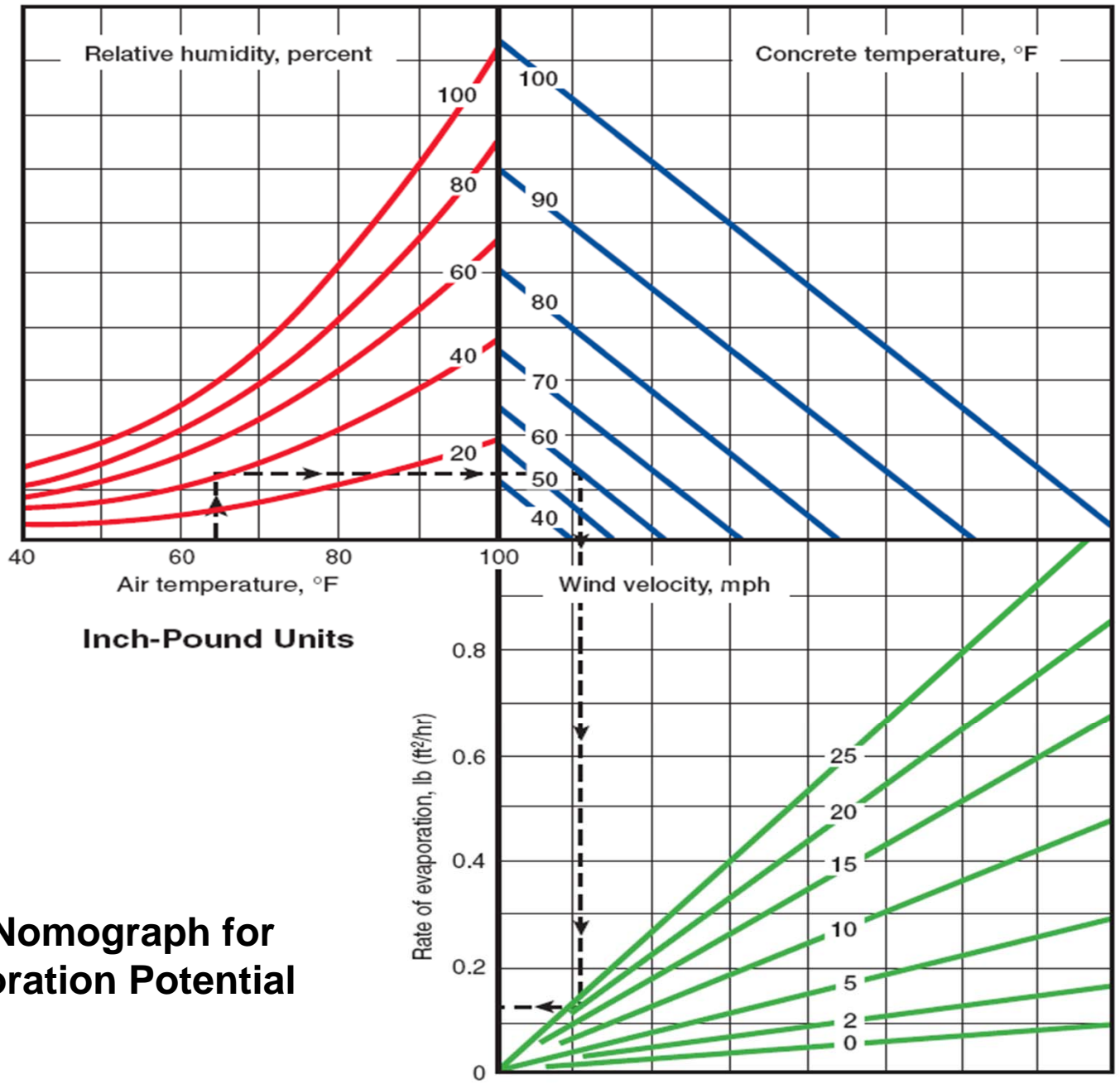

ACI Nomograph for Evaporation Potential

Cumulative Bleeding Rate of Paving Concrete

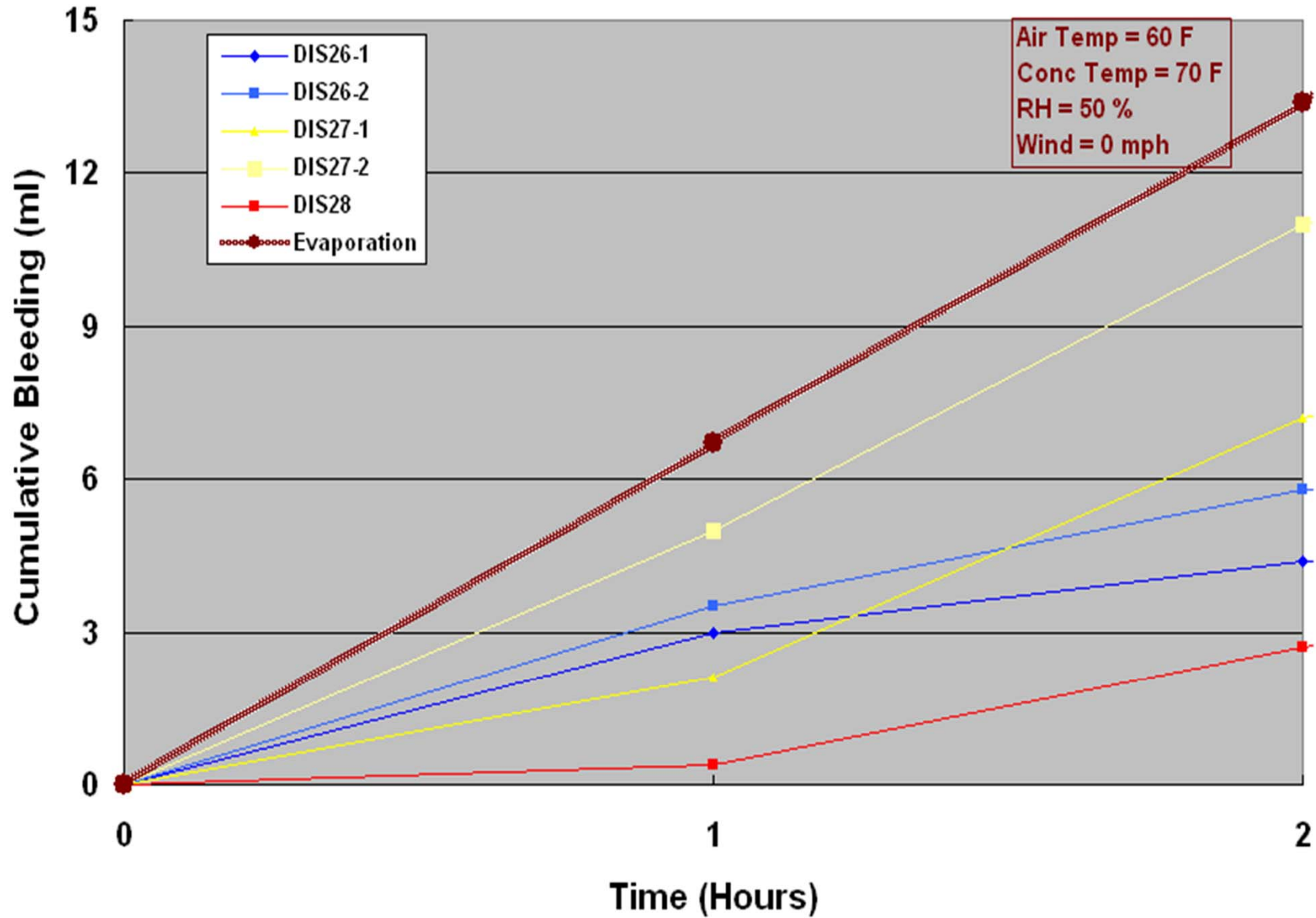

MM 360 + .408





08.11.2009 15:44



08.11.2009 15:57

- 3. Curing Class HES Concrete.** For all Class HES concrete pavement, provide membrane curing in accordance with Section 360.4.I.1, “Membrane Curing,” followed promptly by water curing until opening strength is achieved but not less than 24 hr.



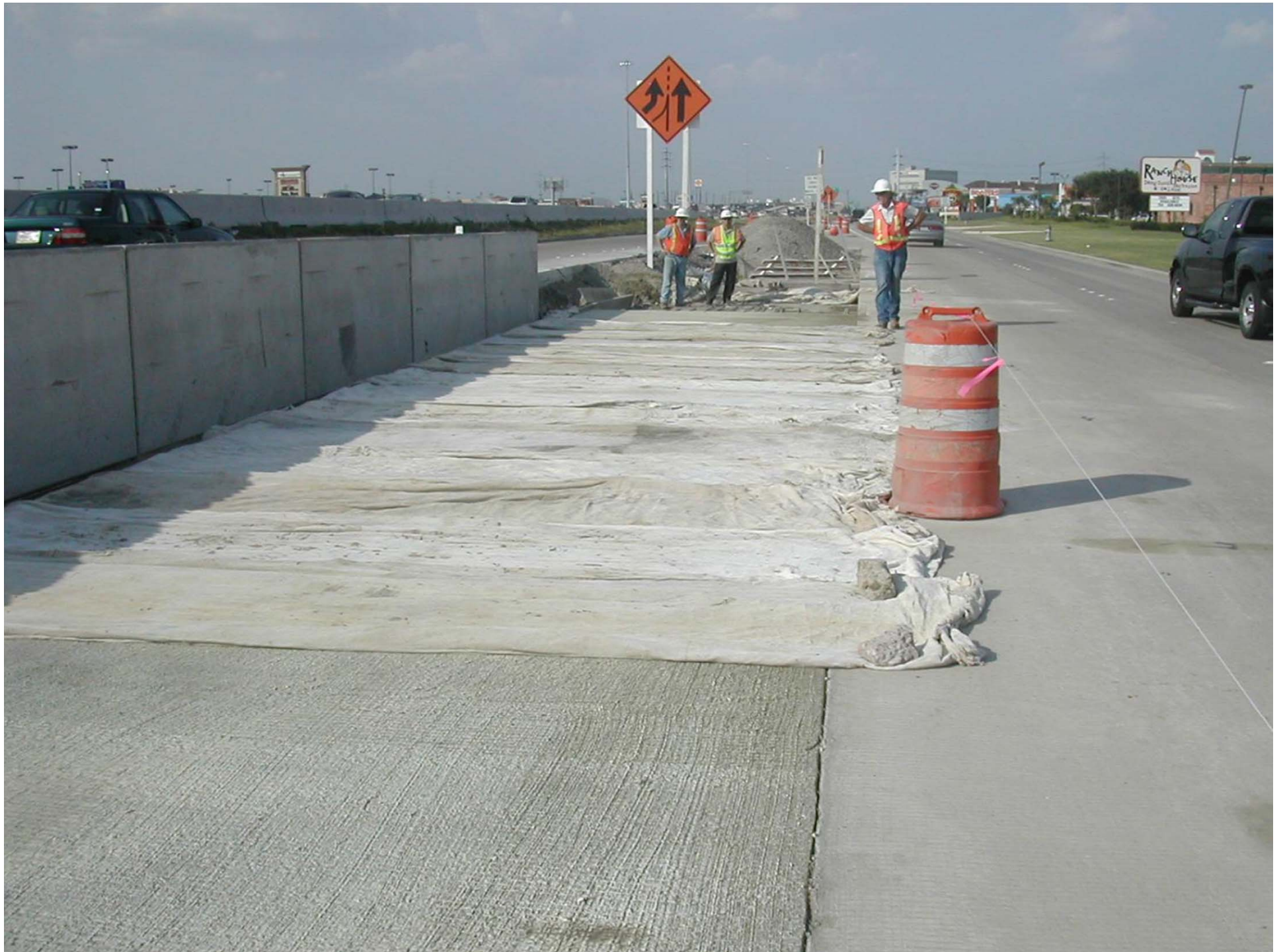

J. Sawing Joints. Saw joints to the depth shown on the plans as soon as sawing can be accomplished without damage to the pavement regardless of time of day or weather conditions. Some minor raveling of the saw cut is acceptable. Use a chalk line, string line, sawing template, or other approved method to provide a true joint alignment. Provide enough saws to match the paving production rate to ensure sawing completion at the earliest possible time to avoid uncontrolled cracking. Reduce paving production if necessary to ensure timely sawing of joints. Promptly restore membrane cure damaged within the first 72 hr. of curing.



- 1. Protection of Pavement.** Erect and maintain barricades and other standard and approved devices that will exclude all vehicles and equipment from the newly placed pavement for the periods specified. Before opening to traffic, protect the pavement from damage due to crossings using approved methods. Where a detour is not readily available or economically feasible, an occasional crossing of the roadway with overweight equipment may be permitted for relocating equipment only but not for hauling material. When an occasional crossing of overweight equipment is permitted, temporary matting or other approved methods may be required.



Maintain an adequate supply of sheeting or other material to cover and protect fresh concrete surface from weather damage. Apply as needed to protect the pavement surface from weather.

- 2. Opening Pavement to All Traffic.** Pavement that is 7 days old may be opened to all traffic. Before opening to traffic, clean pavement, place stable material against the pavement edges, seal joints, and perform all other traffic safety related work.

- 3. Opening Pavement to Construction Equipment.** Unless otherwise shown on the plans, concrete pavement may be opened early to concrete paving equipment and related delivery equipment after the concrete is at least 48 hr. old and opening strength has been demonstrated in accordance with Section 360.4.K.4, “Early Opening to All Traffic,” before curing is complete. Keep delivery equipment at least 2 ft. from the edge of the concrete pavement. Keep tracks of the paving equipment at least 1 ft. from the pavement edge. Protect textured surfaces from the paving equipment. Restore damaged membrane curing as soon as possible. Repair pavement damaged by paving or delivery equipment before opening to all traffic.

4. **Early Opening to All Traffic.** Concrete pavement may be opened after curing is complete and the concrete has attained a flexural strength of 450 psi or a compressive strength of 2,800 psi, except that pavement using Class HES concrete may be opened after 24 hr. if the specified strength is achieved.
 - a. **Strength Testing.** Test concrete specimens cured under the same conditions as the portion of the pavement involved.

L. Pavement Thickness. The Engineer will check the thickness in accordance with Tex-423-A unless other methods are shown on the plans. The Engineer will perform 1 thickness test consisting of 1 reading at approximately the center of each lane every 500 ft. or fraction thereof. Core where directed in accordance with Tex-424-A to verify deficiencies of more than 0.2 in. from plan thickness and to determine the limits of deficiencies of more than 0.75 in. from plan thickness. Fill core holes using a concrete mixture and method approved by the Engineer.

- 1. Thickness Deficiencies Greater than 0.2 in.** When any depth test measured in accordance with Tex-423-A is deficient by more than 0.2 in. from the plan thickness, take one 4-in. diameter core at that location to verify the measurement.

If the core is deficient by more than 0.2 in. but not by more than 0.75 in. from the plan thickness, take 2 additional cores from the unit (as defined in Section 360.4.L.3, "Pavement Units for Payment Adjustment") at intervals of at least 150 ft. and at locations selected by the Engineer, and determine the thickness of the unit for payment purposes by averaging the length of the 3 cores. In calculations of the average thickness of this unit of pavement, measurements in excess of the specified thickness by more than 0.2 in. will be considered as the specified thickness plus 0.2 in.

2. Thickness Deficiencies Greater than 0.75 in. If a core is deficient by more than 0.75 in., take additional cores at 10 ft. intervals in each direction parallel to the centerline to determine the boundary of the deficient area. The Engineer will evaluate any area of pavement found deficient in thickness by more than 0.75 in. but not more than 1 in. As directed, remove and replace the deficient areas without additional compensation or retain deficient areas without compensation. Remove and replace any area of pavement found deficient in thickness by more than 1 in. without additional compensation.

3. Pavement Units for Payment Adjustment. Limits for applying a payment adjustment for deficient pavement thickness from 0.20 in. to not more than 0.75 in. are 500 ft. of pavement in each lane. Lane width will be as shown on typical sections and pavement design standards.

For greater than 0.75 in. deficient thickness, the limits for applying zero payment or requiring removal will be defined by coring or equivalent nondestructive means as determined by the Engineer. The remaining portion of the unit determined to be less than 0.75 in. deficient will be subject to the payment adjustment based on the average core thickness at each end of the 10 ft. interval investigation as determined by the Engineer.

Shoulders will be measured for thickness unless otherwise shown on the plans. Shoulders 6 ft. wide or wider will be considered as lanes. Shoulders less than 6 ft. wide will be considered part of the adjacent lane.

Limits for applying payment adjustment for deficient pavement thickness for ramps, widenings, acceleration and deceleration lanes, and other miscellaneous areas are 500 ft. in length. Areas less than 500 ft. in length will be individually evaluated for payment adjustment based on the plan area.

B. Deficient Thickness Adjustment. Where the average thickness of pavement is deficient in thickness by more than 0.2 in. but not more than 0.75 in., payment will be made using the adjustment factor as specified in Table 2 applied to the bid price for the deficient area for each unit as defined under Section 360.4.L.3, “Pavement Units for Payment Adjustment.”

Table 2
Deficient Thickness Price Adjustment Factor

Deficiency in Thickness Determined by Cores (in.)	Proportional Part of Contract Price Allowed (adjustment factor)
Not deficient	1.00
Over 0.00 through 0.20	1.00
Over 0.20 through 0.30	0.80
Over 0.30 through 0.40	0.72
Over 0.40 through 0.50	0.68
Over 0.50 through 0.75	0.57