



TEXAS TECH UNIVERSITY

Multidisciplinary Research in Transportation

Hydraulic Performance of Type-H Inlets

Theodore G. Cleveland, Kenneth A. Rainwater,
Sergey Smirnov, Wade Barnes, Larissa DaCosta,
Bijay Basnet, Martin Azese, Zeferino Mendoza,
Kirsten Singleton, Holly Murphy, and Annabell Ulary

Texas Department of Transportation

NOTICE

The United States Government and the State of Texas do not endorse products or manufacturers. Trade or manufacturers' names appear herein solely because they are considered essential to the object of this report

Technical Report Documentation Page

1. Report No. FHWA/TX-09/0-5823-1	2. Government Accession No.	3. Recipient's Catalog No.	
4. Title and Subtitle Hydraulic Capacity of Type-H Inlets		5. Report Date August 2010	
		6. Performing Organization Code	
7. Author(s) Theodore G. Cleveland, Kenneth A. Rainwater, Sergey Smirnov, Wade Barnes, Larissa DaCosta, Bijay Basnet, Martin Aziz, Nino Mendoza, Kirsten Singleton, Holly Murphy, and Annabell Ulary		8. Performing Organization Report No. 0-5823-1	
9. Performing Organization Name and Address Texas Tech University, Water Resources Center 10 th and Akron, Room 203 Lubbock, TX 79409-1022		10. Work Unit No. (TRAIS)	
		11. Contract or Grant No.	
12. Sponsoring Agency Name and Address Texas Department of Transportation Research and Technology Implementation Office P.O. Box 5080 Austin, TX 78763-5080		13. Type of Report and Period Covered Technical Report 1 Sep 2006 – 31 Aug 2009	
		14. Sponsoring Agency Code	
15. Supplementary Notes Project performed in cooperation with the Texas Department of Transportation and the Federal Highway Administration.			
16. Abstract Type H Inlets are frequently used by the Texas Department of Transportation as median drains for divided highways. Despite frequent use, engineers do not have adequate design information to mathematically describe the hydraulic performance of these structures. Typically, it has been assumed that IL-H-G and IL-H-L function essentially the same as road-way grates or curb inlets, but there is no basis for that assumption. Type-H drop inlets were investigated using a database from literature-reported experiments for similar inlets and physical model studies conducted at Texas Tech University. The findings of this study are: Type-H inlets, as studied, perform similar to the HEC-22 expectations when the weir-type conditions are applied (Equation (4-26) in HEC-22). Orifice-type models could not explain the TTU or the literature-derived observations. A power-law model that uses the dimensionless groups suggested by Cassidy (1966), with the slopes omitted, provides a reasonable explanation of inlet behavior. SWMM was investigated as a predictive tool by comparison to the TTU experimental results. The SWMM model was subject to very minimal calibration yet predicted performance reasonably well, especially when full inlet capture may occur. Examples of performance prediction using HEC-22, the power-law model and SWMM are presented to provide some guidance for Type-H inlet design.			
17. Key Words TYPE-H INLETS, INLET HYDRAULICS, PHYSICAL MODEL.		18. Distribution Statement No restrictions. This document is available to the public through the National Technical Information Service, Springfield, Virginia 22161, www.ntis.gov	
19. Security Classif. (of this report) Unclassified	20. Security Classif. (of this page) Unclassified	21. No. of Pages 241	22. Price

Hydraulic Capacity of Type-H Inlets: Final Report

by

Theodore G. Cleveland, Associate Professor,
TechMRT, Texas Tech University

Kenneth A. Rainwater, Professor,
TechMRT, Texas Tech University

Sergey Smirnov, Assistant Professor,
Mechanical Engineering, Texas Tech University

Wade Barnes, Larissa DaCosta, Bijay Basnet,
Graduate Research Assistants,
Civil and Environmental Engineering, Texas Tech University

Martin Aseze, Graduate Research Assistant,
Mechanical Engineering, Texas Tech University

Abhijeet Bobde, Graduate Research Assistant
Civil and Environmental Engineering, University of Houston

Zeferino Mendoza, Kirsten Singleton, Holly Murphy, and Annabell Ulary,
Undergraduate Research Assistants,
Civil and Environmental Engineering, Texas Tech University

Research Report 0-5823-4 (Final Report)
Research Project 0-5823

Research Project Title: Hydraulic Performance Evaluation of Horizontal Inlet Type H

Sponsored by the Texas Department of Transportation
August, 2009

Texas Tech University
Texas Tech Center for Multidisciplinary Research in Transportation (TechMRT)
Department of Civil and Environmental Engineering
10th and Akron
Box 41023
Lubbock, Texas 79409-1023

Disclaimer

The contents of this report reflect the views of the author(s), who is (are) responsible for the facts and the accuracy of the data presented herein. The contents do not necessarily reflect the official view or policies of the Federal Highway Administration (FHWA) or the Texas Department of Transportation (TxDOT). This report does not constitute a standard, specification, or regulation. This report is not intended for construction, bidding, or permit purposes. The United States Government and the State of Texas do not endorse products or manufacturers. Trade or manufacturers names appear herein solely because they are considered essential to the object of this report. The researcher in charge of this project was Dr. Kenneth A. Rainwater at Texas Tech University.

There was no invention or discovery conceived or first actually reduced to practice in the course of or under this contract (to date), including any art, method, process, machine, manufacture, design, or composition of matter, or any new useful improvement thereof, or any variety of plant, which is or may be patentable under the patent laws of the United States of America or any foreign country.

Acknowledgments

The four graduate students (Barnes, DaCosta, Basnet, and Aseze) and five undergraduate students (Murphy, Ulary, Singleton, Johnson, and Mendoza) at Texas Tech listed as co-authors played a huge role in the accomplishment and completion of the experimental program reported herein, specifically in the completion of the experimental apparatus construction and operation in the summer of 2009. They performed above and beyond expectations despite consecutive days of one hundred degree laboratory temperatures and the best efforts of circumstance to bring the project to a standstill. Without their efforts, the research reported in this document would not have been accomplished.

Dr. William Asquith and Ms. Meghan Roussel of the U.S. Geological Survey (USGS) provided much needed help in the loan of instrumentation and the requisite training to use that instrumentation, in addition to preparing a DVD on how to weld aluminum that allowed the construction of a key component without waiting for commercial fabrication. Without their help (and the generosity of the USGS) the experimental program could not have been completed.

Mr. Brad Thornhill and Mr. Doug Hayes of the Department of Civil and Environmental Engineering at Texas Tech University built the trapezoidal channel and drop vault. Dr. Chuck Newhouse and Mr. Timothy Wood of the Department of Civil and Environmental Engineering at Texas Tech University designed structural components of the research apparatus and produced shop drawings that were used to construct the actual flume. Mr. Shannon Hutchinson of the Department of Civil and Environmental Engineering at Texas Tech University provided needed help during overhead demolition operations and lifted the force main pipe on the large pump. Their collective design and construction assistance is greatly appreciated. The seamless cooperation of TechMRT and the Water Resources Center at Texas Tech in sharing certain responsibilities also contributed greatly to the completion of this research.

Finally, Mr. Stan Hopfe, Dr. Jack Kaiser, Mr. Jamie Villena-Morales, Ms. Amy Ronnefeldt, Mr. George R. Herrmann, Ms. Diane Venble, Mr. David Zwernemann, Ms. Sandra Kaderka, Dr. German Claros, Mr. Wade Odell, and the remainder of the TxDOT project advisory committee's guidance and patience is greatly appreciated.

**0-5823 Type-H Inlet Study
Final Report**

Contents

1	Introduction	8
2	Literature Review	11
2.1	Inlet Capacity Studies - Typical Experimental Design	12
2.2	Findings of Prior Researchers	13
2.2.1	Inlet Capacity - Grate Inlets	14
2.2.2	Inlet Capacity - Curb and Gutter Inlets	17
2.2.3	Debris Handling	18
2.3	Design Guidelines	19
3	Research Methods	20
3.1	Literature-Derived Performance Data	20
3.2	Experimental Apparatus	20
3.3	Experimental Configurations	22
3.3.1	Single-Inlet, Grate-Top Models	22
3.3.2	Single-Inlet, Lid-Top Models	24
3.3.3	Tandem-Inlet, Grate-Top Models	26
3.4	Instrumentation	30
3.4.1	Flow Depth and Flow Width Measurement	30
3.4.2	Velocity Measurement	32
3.4.3	Discharge Computation	33
4	Research Results	35
4.1	TTU Results Compared to Prior (Literature-Derived) Work	35
4.1.1	Relationship of Approach Discharge and Capture Discharge	35
4.1.2	Relationship of Approach Depth and Capture Discharge	36
4.1.3	Relationship of Approach Froude Number and Capture Discharge	38
4.1.4	Relationship of Approach Length Ratio and Approach Depth Ratio and Cap- ture Discharge	39
4.2	TTU Exploratory Data Analysis	39
4.2.1	Grated and Un-grated Inlets	40
4.2.2	Sump and By-Pass Conditions	41
4.2.3	Inlet Configurations	45
4.3	Results Summary	46
5	Data Analysis and Interpretation	48
5.1	Analysis of TTU Experiments using HEC-22 Methodology	48
5.1.1	TTU configurations as Sag Location Inlets	48

5.1.2 TTU configurations as Median (Non-Sag) Location Inlets 50

5.2 Analysis of TTU and Literature Derived Data using Power-Law Models 51

5.2.1 Literature-Derived Data Model — Extrapolated to TTU Experiments 54

5.2.2 Experiment-Derived Data Model — Extrapolated to Literature Results 56

5.2.3 Collective Data Model — Using Literature-Derived and Experimental Results 58

5.3 Analysis of TTU Experiments using SWMM 60

5.3.1 SWMM Background 60

5.3.2 SWMM representation of TTU laboratory apparatus 62

5.3.3 Representative SWMM simulations 65

6 Type-H Inlet Performance Prediction 69

6.1 Type-H Inlet Performance Prediction, Non-Sag Conditions 69

6.1.1 Performance Prediction using HEC-22 in Non-Sag Conditions 70

6.1.2 Performance Prediction using Power-Law Model in Non-Sag Conditions 76

6.1.3 Performance Prediction using SWMM in Non-Sag Conditions 77

6.2 Type-H Inlet Performance Prediction, Sag Conditions 82

6.2.1 Performance Prediction using HEC-22 in Sag Conditions 82

6.2.2 Performance Prediction using Power-Law Model in Sag Conditions 86

6.2.3 Performance Prediction using SWMM in Sag Conditions 87

6.2.4 Performance Prediction using SWMM in Sag Conditions, partial capture 88

7 Summary, Conclusions, and Suggestions 89

7.1 Summary 89

7.2 Conclusions 90

7.3 Suggested Design Approach 90

7.4 Suggested Future Research 91

8 Appendix-I Texas DOT Type-H Inlet Drawings 95

9 Appendix-II Literature Derived Performance Database 101

10 Appendix-III Texas Tech Experiment Database 204

11 Appendix-IV Relevant Charts for Inlet Design. 229

1 Introduction

Type H Inlets are frequently used by the Texas Department of Transportation as median drains for divided highways. Two varieties of Type H inlets are used. One of them is the Horizontal Inlet (Type H) with grate top and the other is the Horizontal Inlet (Type H) with lid. These are illustrated in TxDOT construction details IL-H-G and IL-H-L, which are included in Appendix-I. Despite frequent use, engineers do not have adequate design information to mathematically describe the hydraulic performance of these structures.

Typically, it has been assumed that IL-H-G and IL-H-L function essentially the same as roadway grates or curb inlets, but there is no basis for that assumption. However, the placements in which the horizontal inlets can be used deviate substantially from those of a roadway grate or curb inlets.



Type-H (IL-H-G) In non-sag conditon



Type-H (IL-H-G) In sag condition

Figure 1: Representative Type-H Inlets

Figure 1 is a pair of images of Type-H inlets in a non-sag and sag condition. The left panel is a non-sag conditions, flow would approach from the left of the image and be intersected by the inlet that lies in the trapezoidal concrete section. A fraction of flow would reasonably be expected to bypass such a configuration. The inlet vault box is the size of the grate and the walls in the space between the grate and inlet are gently sloped to the vault. This inlet is “Traffic-Safe” in the sense that a vehicle wheel will be prevented form entering the inlet. A bicycle wheel might be able to enter this inlet, but the inlet is locates outside bicycle travel lanes, so “Bicycle-Safe” is not relevant in this placement.

The right panel is a Type-H inlet in a sag near Jarrell, Texas. The elevation of the edge of the concrete apron in the image is substantially higher than the edge of the inlet. The image does not convey the vertical relief of the actual placement. This particular inlet has vertical walls in the space between the grate longitudinal bars (horizontal in the image). In the context of “Traffic-Safe,” this inlet is designed to prevent the wheel of a vehicle from entering the inlet; bicycle and pedestrian traffic (if the location were actually in such a location) would be impeded.

Median and roadside ditches may be drained by such drop inlets. Figure 2 illustrates a traffic-safe median inlet. Small dikes downstream of drop inlets (Figure 2) can be provided to impede bypass

flow in an attempt to cause complete interception of the approach flow. These dikes, also called “ditch blocks,” appear in the sketch as the dashed trapezoid downstream of the inlet and are labeled in Figure , which depicts the two sections indicated in Figure 2

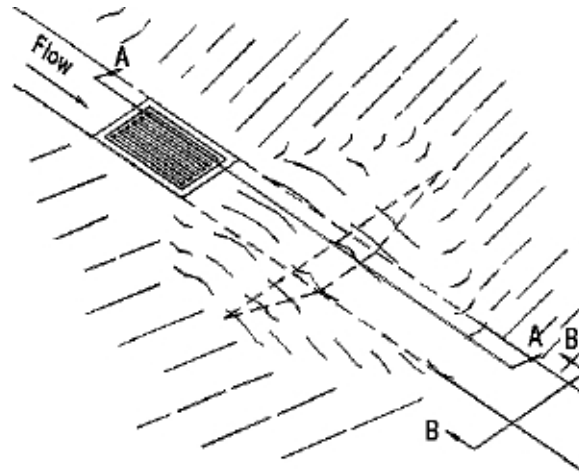

Figure 2: Median drop inlet with a ditch block Adapted from Figure 4-23, Page 4-85, HEC-22 2nd Ed. (Brown et al., 2001)

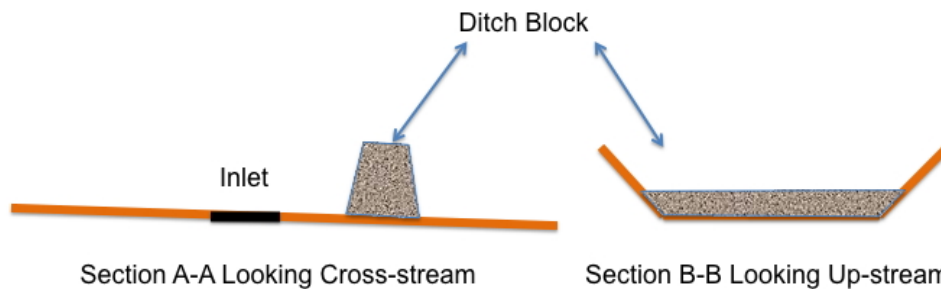

Figure 3: Sections A-A and B-B referenced in Figure 4-23, Page 4-85, HEC-22 2nd Ed. (Brown et al., 2001)

In the HEC-22 manual (Brown et al., 2001) the discussion discussion of the ditch blocks states

“The dikes usually need not be more than a few inches high and should have traffic safe slopes. The height of dike required for complete interception on continuous grades or the depth of ponding in sag vertical curves can be computed by use of chart 9.”

Chart 9 of HEC-22 is a graphical solution to either a weir equation or an orifice equation (depends on the depth) relating ponding depth to inlet discharge.

The objectives of this project are to evaluate the hydraulic performance of the horizontal inlets, both grate-top and lid-top through physical testing, and to synthesize the results of that testing into a series of algorithms for design use. Pursuant to these objectives a large experimental apparatus was

constructed at Texas Tech university to support this and future hydraulic research activities.

The following tasks were performed to accomplish the objectives:

1. Present quantitative and qualitative experimental results obtained from the Texas Tech flume apparatus for inlets morphologically similar to Type-H inlets.
2. Interpret these results in the context of these experiments as stand-alone research and in comparison to similar studies discovered in the literature, particularly in comparison to FHWA HEC-22.
3. Present guidance and recommendations for estimation of Type-H inlet performance.

The remainder of the report is organized into the following chapters. Chapter 2 is a review of prior work (a literature review) regarding similar studies. Data from these studies were digitized and used later in the data analysis chapter. Chapter 3 is a description of the methods for this research, particularly the measurement technology eventually selected. This chapter also includes a tabulation of the experimental configurations that were examined. Chapter 4 presents the results from the Texas Tech experiments (in reduced form). Chapter 5 is an analysis of the literature database and the experimental database from the Texas Tech experiments. This chapter also contains an interpretation of the results of the data analysis in the context of a design tools to supplement the HEC-22 methodology to reflect the findings from the present work. Chapter 6 is a summary of the report, along with example performance prediction using various design tools, and suggestions for future work.

2 Literature Review

Inlet design for highway drainage is a complex process because the designer needs to balance several competing objectives: high capacity for flow interception, operational safety, constructibility, and maintenance economy. These types of inlets (including Type-H) are generally categorized as drop-inlet structures and are intended for use in median and roadside ditches. The TxDOT Hydraulic Design Manual (2004), Chapter 10, Section 5, provides design guidance for several inlet types used for pavement drainage. These structures include curb inlets, grated inlets, and slotted drains¹. Included in that chapter are necessary formulae and charts, along with detailed computation examples. The focus of this material is roadside drainage, primarily at the curb. Methods presented include use of combination inlets, inlets in sag configurations, and carryover design approaches. The majority of the methods appear derived by reference from Brown et al. (2001).

Sources for these procedures appears to originate from selected reports including Larson (1947), Larson (1948), Cassidy (1966), TRB (1969), Burgi and Gober (1978), Burgi (1978a), Burgi (1978b). These reports present methods based on experimental studies of inlets that are morphologically similar to the Type-H inlets in this study. More recent experimental studies with morphologically similar inlets include Kranc and Anderson (1993), McEnroe et al. (1999), and Kranc (2000). These reports contain sufficient documentation to recover the experimental results in some fashion, and this data recovery was performed as part of this current study.

The purpose of the prior experiments was to identify an efficient grate inlet with a balance of the following qualities.

1. Hydraulically efficient. The definition of the term “efficiency” varies slightly with different researchers, however Brown et al. (2001) refers to the efficiency as the volume intercepted per unit volume of approach flow, here approach flow is the total flow in the gutter flowing towards the inlet. This flow ratio is common to all the prior studies. Equation 1 represents this definition:

$$\epsilon = \frac{Q_{inlet}}{Q_{total}} = 1 - \frac{Q_{co}}{Q_{total}} \quad (1)$$

where, Q_{total} is the total approach discharge, Q_{inlet} is the discharge intercepted by the inlet, and $Q_{co} = Q_{total} - Q_{inlet}$ is the carry-over discharge (discharge not intercepted by inlet).

2. Safety in operation. Relatively recent work on inlet grates to accommodate bicycle and pedestrian use focuses on user safety. The principles involved apply in Type-H applications (except bicycle and pedestrian issues may be irrelevant depending on location).
3. Strength. Sufficient strength to support intermittent vehicle loading without deformation or damage (to the inlet, or vehicle).
4. Stability. Probably referring to vehicle contact - stable means the grate is not easily dislodged during normal use.

¹Texas Department of Transportation, Hydraulic Design Manual. Austin, TX, 2004.
(available at <ftp://ftp.dot.state.tx.us/pub/txdot-info/gsd/manuals/hyd.pdf>)

5. Self Cleaning. Clogging was a motivation of several studies in the literature. Despite the obvious loss of hydraulic capacity, clogging creates other concerns in bicycle-safe inlets. A handful of the reports mentioned some ad-hoc approaches to address clogging by cross member geometry, shape, and orientation.
6. Economics. Both fabrication and maintenance costs are important.

2.1 Inlet Capacity Studies - Typical Experimental Design

The typical physical experimental design and apparatus for quantification of grate inlet efficiencies is depicted in Figure 4. A typical configuration is a test channel (flume) with the test grate in the bed to intercept the approach discharge. In most of the studies the longitudinal slope (in the flow direction) was adjustable.

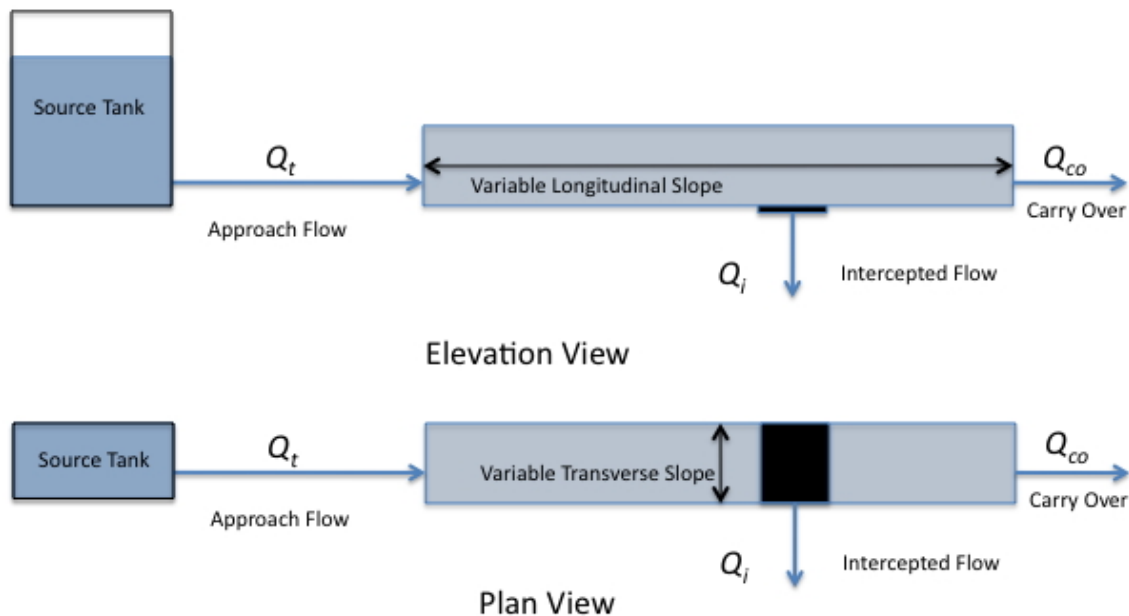

Figure 4: Typical physical modeling configuration.

In some experiments the transverse slope was also adjustable, providing a means to incorporate the hydraulic effect of road crown. Lastly, some experiments included a curb-section. While not specific to in-grade inlets, grated curb inlets are a subset of grate inlets; furthermore the data are deemed valuable as the curb does create an axis of symmetry and these data can be relevant for Type-H guidance. The inflow discharge, surface roughness, and slopes in these channels were then varied over a realistic range to observe hydraulic performance. The resulting measurements then form the database for inlet design computations.

As a minimum, most of the studies collected and reported the following measurements in some

form.

1. Total discharge.
2. Inlet discharge or hydraulic efficiency as defined above.
3. Longitudinal slope (dimensionless, percent slope, or feet-per-mile).
4. Transverse slope (dimensionless, percent slope, or feet-per-mile).
5. Width of spread. This value is important in inlet design for maintaining serviceability of the roadway. If the spread width is too wide, the roadway is flooded and unsafe. Different reports had different goals for what value was acceptable, but the concept was common to all studies.
6. Channel roughness or a similar measure related to flow friction.

A variety of discharge measurement techniques were employed. For example, the U.S. Bureau of Reclamation (Woo and Jones, 1974) used a wooden flume 20 ft long and 35 ft wide to simulate a gutter. The longitudinal slope was varied using a mechanism for tilting the entire set up and transverse slope was fixed at 0.04-dimensionless slope. Flow (approach flow) was measured using a venturi meter at the supply tank for small values and an annular flow meter for large values. Bypass (carryover) flow was measured by a weir. In addition to all these flow measurements, point gages were employed to measure the water depth at the weir crest over the carryover collecting tank and the water depth in the flume. Approach flow was varied from 0.3 cfs to 3.2 cfs and longitudinal slope from 0.005 to 0.130. Roughness coefficient of the flume was varied by use of enamel paint on the inside surface of the wooden flume. Six different grates, each representative of a particular category were tested.

Flow measurement technology has changed since those experiments, and modern techniques would likely use a combination of acoustic velocimetry and/or laser-doppler velocimetry; however, weir flows are simple backups to such tools. None of the reports studied appeared to use mass flow measurements (weigh water as it passes a section), although the laboratories involved had the capacity to make such measurements.

Table 1 compares the selected experimental programs in terms of measurement technologies employed, physical scale, and materials used. Of particular note is that the studies in the table all measured Q_{co} and computed Q_{inlet} from conservation of volume principles, a likely consequence of adapting existing flumes with overflow weirs to these kinds of experiments.

2.2 Findings of Prior Researchers

This section summarizes some of the findings reported in the reviewed studies. Some examples of how their results were presented are illustrated and synthesized in this section.

Table 1: Comparison of Experimental Methods

Characteristic	USBR	Organization		
		Florida DOT	Minnesota DOT	Neenah Inc.
Geo. Scale	1:1.27	1:2	1:1	1:1
Length (feet)	20	20	21	25
Width (feet)	3	–	3	4
Q_t (cfs)	0.003–3.2	–	–	–
Slope (Long.)	0.005–0.130	0.008–0.08	0–0.06	0.001–0.01
Material	Wood	PVC	Masonite	Concrete
Inlets studied	6	3	9	–
Meas. Q_t	Venturi, Annular	–	Orifice ΔP	Orifice ΔP
Meas. Q_{co}	Weir	–	Weir	Weir
Debris Test	No	No	Yes	No

2.2.1 Inlet Capacity - Grate Inlets

The results in all reports were presented graphically. The inlet interception capacity was plotted against each of the various factors that affected the behavior of the inlets (longitudinal slope, approach flow quantity, cross slope, and surface roughness of the inside of the test bed) while keeping the other factors constant for each test.

Figure 5 shows an example of a plot of hydraulic efficiencies against various values of approach flows for different grates. This chart is representative of the type of result presentations in all reports examined by the research team. The different curves on the chart are different grates, notice the chart is dimensional, that is the discharge is in units of L^3/T . The chart shows the anticipated response for the grates tested; specifically that the hydraulic efficiency (inlet flow fraction) declined with increase in the total flow. For lower values of total flow some of the inlets intercept 100%. Charts such as these and the tabulated results from which these charts were built were used in the present study to construct a database of inlet performance.²

The Minnesota DOT (Larson, 1947) study noted that acceptance of a prescribed amount of carry-over (deliberately by increasing total gutter flow and/or longitudinal slope) considerably increases the efficiency (flow fraction intercepted) of the inlet. The increase was because the inlet head was increased (deeper submergence), and because of the way efficiency is defined (flow fraction). The report stated that a carryover allowance of 0.10 to 0.20 cfs increases the interception capacity by almost 100%.

Findings of the experiments done by other researchers are summarized in the following list.

1. The inlet hydraulic capacity was affected by the characteristics of the inlet as well as the characteristics of the approach flow.

²The literature derived database is described later in this report, and listed in Appendix II.

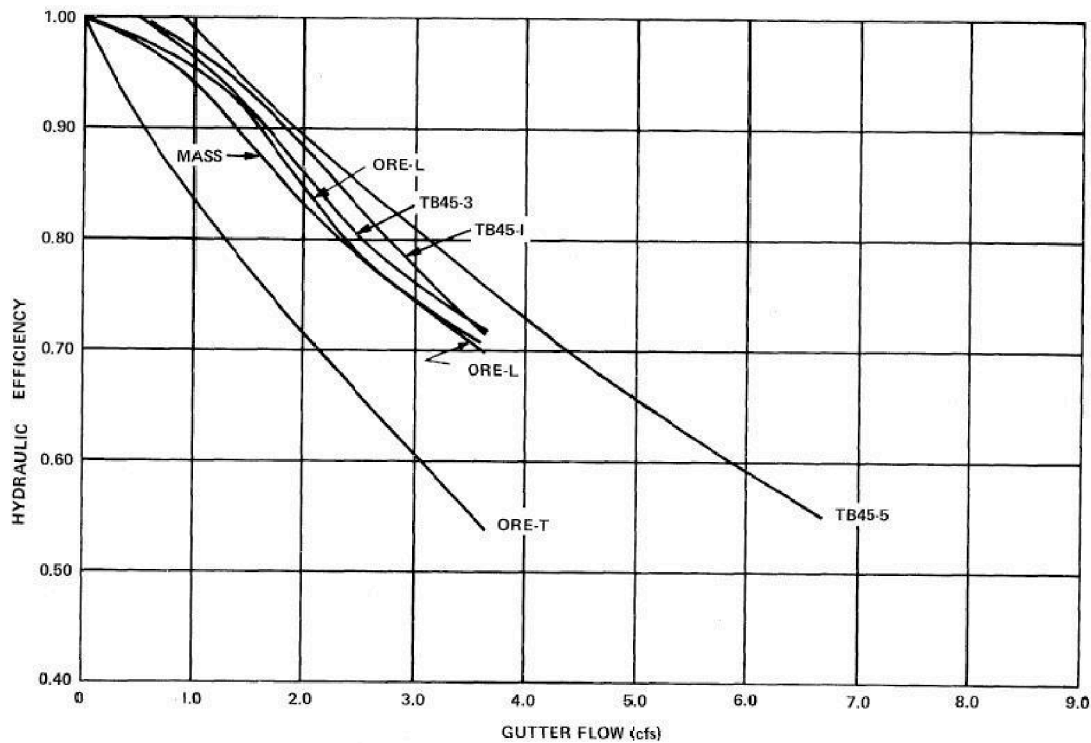

Figure 5: Typical results presentation (Woo and Jones, 1974)

2. Variations in the approach flow produced different effects depending on the characteristics of the inlet.
3. The efficiency of a grate inlet to intercept all or a part of the gutter flow depended on the configuration and length of the grate as well as the longitudinal slope of the bed.
4. Any transverse elements (elements normal to the direction of flow) on a grate tended to cause the water to splash and skip over the grate, thereby increasing the carryover and reducing efficiency.
5. Experiments to date were incapable of fully explaining the differences in behavior of different inlets from carryover that bypassed the inlet by virtue of splashing as compared to carryover water simply flowing around the inlet. As a practical guideline, the interception width of the inlet was limited to the water flowing in the portion equal to the width of the grate.

Additionally, a study of inlets (Woo and Jones, 1974) with and without tilted transverse bars showed that tilting the bars to provide a greater vertical opening on the upstream face always increased the efficiency for all test conditions and further increased with increase in spacing of the transverse bars.

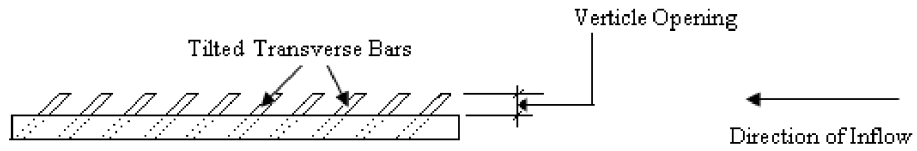

Figure 6: Schematic (profile view) of tilted-bar inlet. Each bar acts like a scoop. (Woo and Jones, 1974)

Figure 6 shows the cross section of an inlet with tilted transverse bars. Although the transverse bars act like scoops, this particular arrangement is also taking advantage of the Coanda effect (Reba, 1966; Wahl, 1995), where the high speed flow will bend around an object if the approach angle is ideal. Figure 7 is an image of such an inlet in service (near Seattle, WA).



Figure 7: Image of a slanted vane inlet in service.

The prior research found that if widely spaced longitudinal bars are incorporated to maximize

interception and transverse elements are avoided, the inlet would be hydraulically efficient but not safe for bicycle riders and pedestrians — an open hole being the most efficient design in this context.³ Conversely, closely spaced longitudinal and transverse bars would be safe, but severely restrict the interception of incoming flow, in the limit behaving as a porous medium with negligible interception in the context and time frame of highway drainage for which inlets are currently used.

Larson (1947) determined that rounded bars as grate elements increased the effective length of openings in the grates. For example, for a given length and width of an inlet, if rounded bars are used instead of square bars, the area of openings was slightly increased with proportionate interception capacity increase. The mechanics of this increase is a manifestation of the Coanda-effect caused by the circular path presented by the bar cross section. In liquid systems this effect is usually quite small, and Larson's observations are of some significance from a scientific standpoint. Rectangular bars are easier to fabricate and are likely to remain the geometry of choice.

Kranc (2000) observed that the inlet performance depended primarily on the upstream depth and less on other factors like bed slope or velocity. His experiments also observed that lowest slope was not the most efficient slope, because at low velocities on flat slope transverse spread was considerably greater and the inlet was not able to intercept all of the flow. Although higher velocities of approach flow tended to cause splashing over the grates and reduce interception, thus favoring a reduction in slope if possible, there was also a simultaneous increase in interception of flow because more water was concentrated in the area covered by the width of the inlet. His experiments also reported that forced ponding near the inlet by introducing a barrier downstream of inlet could increase interception by about 35%.

2.2.2 Inlet Capacity - Curb and Gutter Inlets

McEnroe and others (1999) studied 4 standard designs for curb and gutter inlets, the concrete gutter inlet, a curb inlet, and a combination inlet. The hydraulic model studies of these inlets were carried out in the University of Kansas at one-quarter scale using a simulated roadway with variable longitudinal and cross slope. The test roadway was 15 m long and set up with weir for discharge measurement. There was also a V-notch weir which was calibrated using a head-discharge relationship. Tests were carried out with longitudinal slopes of 0.5 %, 1%, 2%, 3% and 5% and with cross slopes of 1.6%. The objective was to determine the relationships between the captured and total discharge. McEnroe and others (1999) found that relationship between captured discharge and total discharge for each set-up can be represented by design curves that relate different inlets to performance. In some cases, these design curves applied to all the inlets and in some cases a separate design curve applied. They also observed that the grade had little effect on the inlets. The performance of some inlets is marginally better on steep grades (up to 5%) than on mild grades (around 0.5%) and the reverse was true for other inlets. All of the inlets perform better on steeper

³The present experiments suggest that an open hole is not the most efficient in outlet restricted flow — the grates actually break inlet vortices and increase capacity.

cross slopes⁴.

Type-H inlets with lid tops are anticipated to behave more similarly to curb-type than to grate-type studies, hence the consideration of prior work in this area.

2.2.3 Debris Handling

Debris handling was an important theme in the Larson (1947) study. Figure 8 is an image of a grate inlet along a curb. The vehicle travel lanes are towards the top of the image. The image displays typical debris residue build-up after a drainage event, as well as a representative inlet opening size (about the size of a soda bottle – as large as possible but small enough to exclude people’s shoes).



Figure 8: Image of Curb and Grate inlet with debris residue. Image is from a municipal street, but illustrates the debris issue as well as typical grate sizing.

The study examined the response of grate inlets to debris under the assumption that dried leaves were the representative debris. The leaves themselves were simulated using reasonably sized papers. These numbered papers (a drift-tracer concept) were introduced in the approach flow after soaking them completely in water, and then the number of pieces trapped, bypassed and intercepted were counted. Of particular significance these drift paper tracers probably represent a good surrogate for direct measurement of Q_{inlet} , and it is unfortunate that only summary results were presented for these drift tracer studies.

Generally, the experiments showed that the inlets with wider spacing and bars parallel to the flow direction were more efficient (to the order of 95%) in intercepting and passing flows containing debris. For other grates it was observed that once the debris pieces are trapped in the upstream

⁴The present work only considered a single side slope. The improvement observed in prior studies with steeper cross slope is a consequence of the change in geometry forcing deeper approach depths at the inlets, with a correlated increase in operating head. Steeper slide slopes for a constant bottom width would have produced similar findings had the present study been able to investigate the steeper cross slopes.

part of the inlet the frictional pull from water flowing over it may drag and carry off the debris. Specially baffled bars were designed to minimize trapping of debris particles, however these inlets could not deliver satisfactory hydraulic performance. The study was later discontinued.

2.3 Design Guidelines

Principal current design guidelines in the Texas Department of Transportation manual reference to Brown et al. (2001), which is built upon the various studies mentioned in prior sections. The guidance for median inlets begins on page 4-85 of Brown et al. (2001), however relevant guidance also is reported on pages 4-39 of the document. Relevant to this research is the statement in Brown et al. (2001) regarding approach depths and inlet performance. Quoting from Brown et al. (2001),

“Grate inlets in sag vertical curves operate as weirs for shallow ponding depths and as orifices at greater depths. Between weir and orifice flow depths, a transition from weir to orifice flow occurs. . . . Slotted inlets operate as weirs for depths below approximately 50 mm (2 inches) and as orifices at depths greater than 120 mm (5 inches).

These quotes are prescient with respect to the Texas Tech research. The stated flow depths range was examined in the physical modeling study, however the findings disagreed with the guidelines. Of importance is that the flow depths are stated for slotted inlets and not necessarily inlets with the same aspect ratio as the Texas Tech experiments.

The Type-H inlets were not studied directly by Brown et al. (2001), however there was limited discussion of drop inlets and grate inlet performance. The Type-H specifications are certainly a morphological cousin of these already studied principles.

3 Research Methods

The researchers at Texas Tech University employed a large experimental apparatus and conducted scaled physical model experiments. The dimensional scale ratio was approximately one-quarter scale,⁵ with an important deviation in the vertical. The vertical drop in the physical model is smaller than in reality — at the time of the apparatus construction an important component of performance was overlooked,⁶ that is the effect of the pipe away from the drop box to the receiving conduit or outfall. This effect was mimicked by using restrictor plates, but only mimicked.

In addition to the physical modeling studies, the researchers also developed a performance database from the reports cited in the literature review. This database was intended as a tool to guide experimental design as well as enhance design tools built by the researchers.

The remainder of this chapter describes the experimental apparatus, the model configurations, and the measurement technologies employed.

3.1 Literature-Derived Performance Data

A database of inlet performance data was developed from the tabulated and graphed results in various sources discussed in the literature review. Tabular results were directly entered by the researchers. Graphical data were acquired by digitizing scanned images of the graphs using the **G3DATA** computer program. This program allows the analyst to associate pixel positions with numerical values and by simple scaling to extract pseudo-data from a graph. This procedure allows recovery of data from graphical information, greatly extending the ability to construct useable data from old literature.

The guiding document for the literature-derived performance database was the work of Cassidy (1966). In that study, performance was related by dimensional analysis to the approach Froude number and geometric characteristics of the inlet. The Texas Tech researchers also focused on dimensionless representation of their work, believing that dimensionless reporting would enhance analysis and design approaches. Most of the other studies did not report Froude number and the results are for the most part dimensional, however sufficient description was provided by the prior researchers to allow the Texas Tech researchers to reconstruct (by computation) the unreported values. The result of this effort is listed in Appendix II, and the literature derived database was used primarily to validate the Texas Tech studies and develop design guidance.

3.2 Experimental Apparatus

The experimental apparatus was comprised of a recirculating, tiltable flume system, driven by a single axial-flow pump controlled with a variable-frequency drive. As of this writing, the stall speed

⁵The prototype (real world) length dimensions are about 4 times larger than the model length dimensions

⁶The original research supervisor may have been aware of this issue but left the University at the end of project year 1. The remaining researchers became aware of this issue late in the project.

of the pump was on the order of 19 cycles-per-second (about 1/3 power). The researchers have been able to operate the pump by starting at 25 cycles-per-second, and, once momentum is built, the frequency can be dropped to the lower limit and flow maintained. The pump will not initiate water motion below 24 cycles-per-second. The researchers have operated the pump at about 3/4 power and at this setting can produce in excess of 6 cfs in the flume system. The flume is 48 feet long, 8 feet wide, and 4 feet tall. The recirculation tank is roughly 4 times the footprint of the flume itself. A head tank on the upstream end hydraulically disconnects the pump from the flume in an effort to smooth flow oscillations.

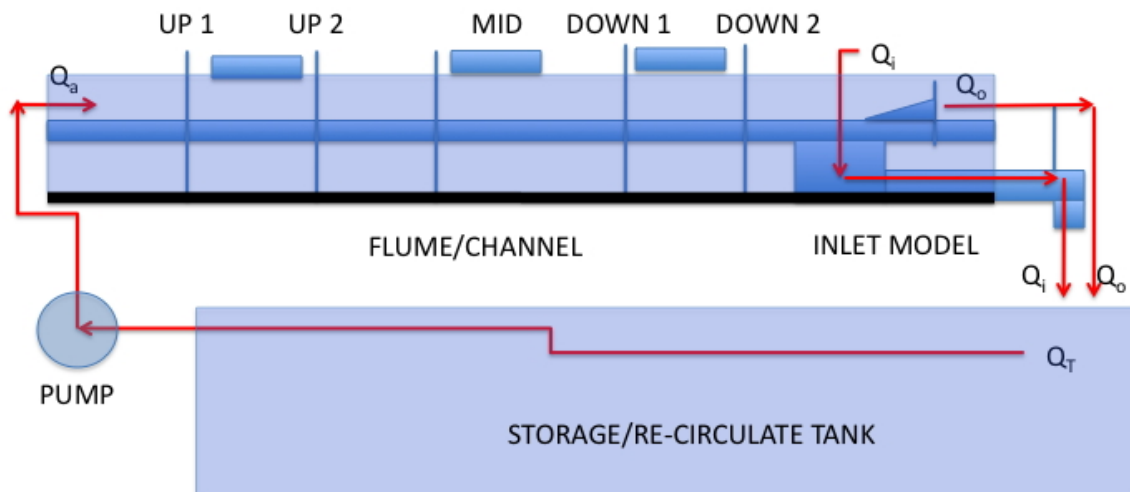

Figure 9: Schematic of experimental apparatus. This sketch indicates the relative position of measurement locations where velocities and flow depths were measured in the study. Significant spatial and temporal averaging was used throughout the study to determine inlet performance.

Figure 9 is a sketch of the system layout. Figure 10 is a view of the system in use. In this image the inlet model is in the foreground, and the head tank with its discharge is visible in the background. The instrument section is in about the middle of the system, with image collection cameras along the left side of the image. To the left of the image is the pumping system and pump control system. Not visible is the computer system immediately adjacent to the flume (next to the cameras). This system captured data, and the data were also downloaded via a private network to a nearby server for analysis and data preservation.

The tilt mechanism was a system of 18 coordinated jack screws, each controlled by one of six variable frequency drives. During this study, the drives were not properly functioning and flume tilt was achieved manually using hydraulic jacks. The head tank, chute, and test bed combinations limited the practical tilt in this study to 2% slope⁷ The instrumentation and measurements are described separately in a subsequent section.

⁷The original plan was to examine up to 5% slope. The test bed could achieve such a slope, but the supply chute invert elevation would be below the model elevation.



Figure 10: View of the system with an experiment in-progress. The image is looking upstream from the end of the flume. In the background the head tank and overflow weir is visible.

3.3 Experimental Configurations

The experimental configurations were comprised of inlet model sets operated at different longitudinal slopes, with different exit pipe invert elevations. The inlet models, as well as the approach channel were constructed of plywood, reinforced where necessary with wooden trusses. The approach channel was roughened by coating with a mixture of 20-40 sieved sand and water resistant paint. The inlet model plenum (plate that holds the inlet vaults) was painted with a oil-based paint to improve visibility in the imaging system. The plenum was not roughened, and in this portion of the model the material was relatively smooth.

Figure 11 is a sketch of the different vault boxes that fit into the flume to represent the vault that would be used in a Type-H installation. Water exits these vaults from the holes in the side and ultimately into a large pipe that carries discharge back to the suction tank for the pumping system. Flow is measured in this large pipe as well as in the approach channel and overflow channel.

3.3.1 Single-Inlet, Grate-Top Models

Figure 12 is a sketch of the single inlet models showing the relative positions of the inlet, the outlet restrictors, the outlet collector pipe, and the ditch block. These models were operated with and without the ditch block. Discharge was measured in the approach section, at the overflow, and in the later experiments in the outlet collector pipe. The single inlet models were operated in two sizes,

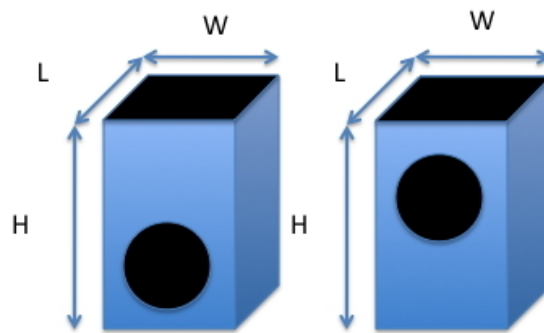

Figure 11: Sketches of inlet vault boxes that attach to the outlet pipe. L and W were varied (1 ft and 2 ft models were built). The depth H was 1.5 ft.

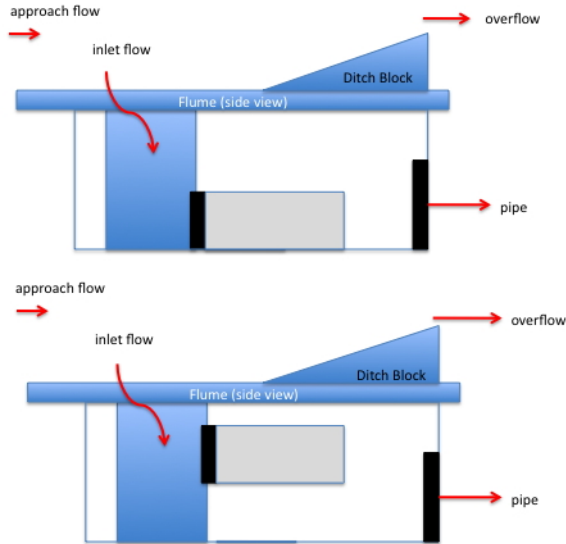

Figure 12: Elevation view sketch of single inlet models. Models are operated with outlet restrictors at different elevations and with and without ditch blocks.

the smaller size was a 1 X 1 ft opening in the top of the vault, the larger size was approximately a 2 X 2 ft opening in the top of the vault. The larger size opening spanned the entire bottom of the model approach channel.

Figure 13 shows images of the single-inlet vault boxes and models in-place. The vaults were built so they could be rotated in the plenum (the portion of the model with the image grid in the right-hand panels). The “grid” that resembles welded wire fabric is an image reference grid painted onto the channel side and bottom. This grid helps in the detection and quantification of drift tracer speed in the post-experiment image analysis. The upper panels are the vault and inlet model for the 2 X 2 ft inlet. On the upper right the ditch block is visible. The lower panels are the vault and inlet model for the 1 X 1 ft inlet. In both images the inlet grate is arranged with the grate bars parallel

to the approach flow direction.



Figure 13: Images of single-inlet vault boxes and models in-place in the experimental flume. Grid in image is painted onto the channel bottom to provide indexing for drift-tracer image interpretation

3.3.2 Single-Inlet, Lid-Top Models

A variation of the single-inlet model replaced the inlet grates with a cap; this configuration was referred to as cap-type inlet. Figure 14 is an image of this variation; internally (under the cap) the inlet was identical to the large-opening, single-inlet model.

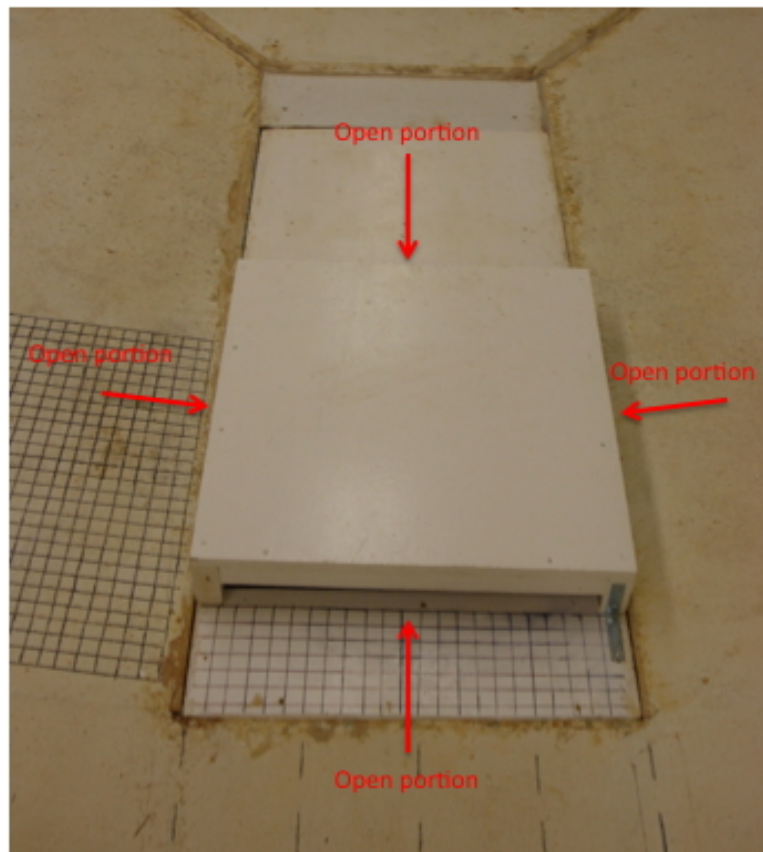

Figure 14: Single inlet with cap. Image is looking downstream. Arrows indicate openings on all sides. Grid in image is painted onto the channel bottom to provide indexing for drift-tracer image interpretation

3.3.3 Tandem-Inlet, Grate-Top Models

Figure 15 is a sketch of the tandem inlet models showing the relative positions of the inlet, the outlet restrictors, the outlet collector pipe and the ditch block. These models were operated with and without the ditch block. Discharge was measured in the approach section, at the overflow, and in the later experiments in the outlet collector pipe. The tandem inlets were operated in-line with the flow path (i.e. in series, and not side-by-side). Measurements were made in the same fashion as in the single inlet models.

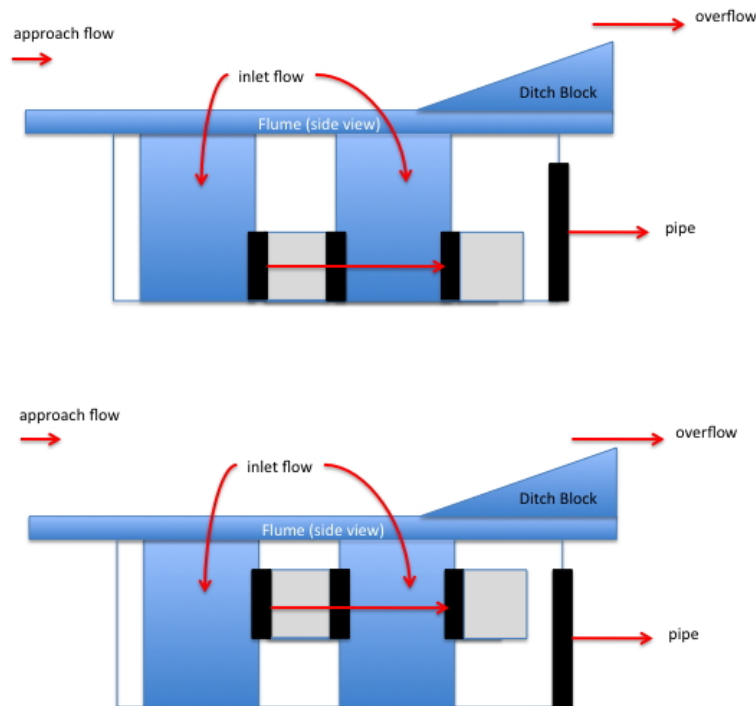

Figure 15: Elevation view sketch of tandem inlet models. Models are operated with outlet restrictors at different elevations and with and without ditch blocks.

Figure 16 is a collection of images of the tandem-inlet models. The figure shows from the lower left hand panel a view looking from the outlet restrictor of the downstream model to the upstream vault box through the internal piping of the tandem inlet. Immediately above is an image of the two vault boxes connected by the internal piping from the side. The image in the right upper panel is an image showing the internal pipe connection details. The last image in the lower right panel is the model installed in the flume.

Each series of inlet types were operated at three different longitudinal slopes. The researchers decided that the slope was the most difficult variable to change, thus the flume slope was set, then each model inlet was placed in the flume and a set of discharges applied and measured. Then the models were switched and the process repeated.



Figure 16: Images of the tandem-inlet vault and in-place model configuration

Table 2 lists the conditions of the actual experiments (the experimental design). In the table, the last serial identification code for a configuration is listed, and the differences in the serial numbers is the number of different flow rates examined. These numbers correspond with the same experiment serial ID numbers in Appendix III.

Table 2: Experimental Design for Type-H Inlet Hydraulic Characteristics Study.

[EX_ID: Serial number of the last experiment in the indicated configuration; S_0 : Longitudinal (in direction of flow) slope, dimensionless; S_C : Transverse (side walls) slope, dimensionless ; PUMP: The number of pump rates for the experimental configuration.; GRATE: Inlet grate bar orientation relative to approach direction. NONE=Open Hole, PARA=Parallel, NORMAL= Perpendicular, LID = Cap inlet, — REAR is the rearmost hole of a tandem inlet, with the front opening blocked. ; BLK: Ditch block (present or absent); INLET: Model description. Format is Length X Width - Number. If Number = 1, then inlet is single inlet. OUTLET: Outlet restrictor conditions. Format is Diameter - Invert Elevation. If Invert Elevation = Low, outlet is at bottom of the vault box, otherwise the crown of the outlet is near the top of the vault.

EX_ID	S_0	S_C	PUMP	GRATE	BLK	INLET	OUTLET
5	0.005	0.167	5	NONE	YES	1X1-1	4-LOW
10	0.005	0.167	5	PARA	YES	1X1-1	4-LOW
12	0.005	0.167	2	PARA	NONE	1X1-1	4-LOW
18	0.005	0.167	6	NONE	YES	1X1-1	4-HIGH
23	0.005	0.167	5	PARA	YES	1X1-1	4-HIGH
27	0.005	0.167	4	NONE	YES	1X1-1	8-LOW
32	0.005	0.167	5	PARA	YES	1X1-1	8-LOW
37	0.005	0.167	5	NORMAL	YES	1X1-1	8-LOW
42	0.005	0.167	7	NONE	YES	1X1-1	8-HIGH
49	0.005	0.167	7	PARA	YES	1X1-1	8-HIGH
50	0.005	0.167	1	NORMAL	YES	1X1-1	8-HIGH
55	0.005	0.167	5	NONE	YES	1X1-2	8-LOW
60	0.005	0.167	7	PARA	YES	1X1-2	8-LOW
61	0.005	0.167	1	NORMAL	YES	1X1-2	8-LOW
65	0.005	0.167	4	PARA	YES	1X1-2	4-LOW
67	0.005	0.167	2	PARA	NONE	1X1-2	4-LOW
71	0.005	0.167	4	PARA	YES	1X1-2	4-HIGH
75	0.005	0.167	4	PARA	YES	1X1-2	8-HIGH
77	0.005	0.167	2	PARA	NONE	1X1-2	8-HIGH
79	0.005	0.167	2	NONE	YES	2x2-1	8-LOW
83	0.005	0.167	4	PARA	YES	2x2-1	8-LOW
85	0.005	0.167	2	PARA	NONE	2x2-1	8-LOW
87	0.005	0.167	2	NONE	YES	2x2-1	12-LOW

Continued on next page

Table 2: Type-H Experiments — Continued

EX_ID	S_0	S_C	PUMP	GRATE	BLK	INLET	OUTLET
91	0.005	0.167	4	PARA	YES	2x2-1	12-LOW
93	0.005	0.167	2	PARA	NONE	2x2-1	12-LOW
97	0.005	0.167	4	PARA	YES	2x4-1	12-LOW
101	0.005	0.167	4	PARA	YES	2x4-1	8-LOW
105	0.005	0.167	4	PARA	YES	2x4-1	4-LOW
108	0.010	0.167	3	PARA	YES	2x4-1	4-LOW
111	0.010	0.167	3	PARA	YES	2x4-1	8-LOW
112	0.010	0.167	4	PARA	YES	2x4-1	12-LOW
114	0.010	0.167	2	PARA	YES	2x4-1	12-LOW
118	0.010	0.167	4	PARA	YES	2x2-1	12-LOW
122	0.010	0.167	4	PARA	YES	2x2-1	8-LOW
126	0.010	0.167	4	PARA	YES	2x2-1	4-LOW
129	0.010	0.167	3	LID	YES	2x2-1	4-LOW
132	0.010	0.167	3	LID	YES	2x2-1	8-LOW
135	0.010	0.167	3	LID	YES	2x2-1	12-LOW
137	0.010	0.167	2	PARA	NONE	2x2-1	12-LOW
139	0.010	0.167	4	PARA	NONE	2x2-1	8-LOW
141	0.010	0.167	2	PARA	NONE	2x2-1	4-LOW
145	0.010	0.167	4	PARA	YES	1x1-1	4-LOW
149	0.010	0.167	4	PARA	YES	1x1-1	8-LOW
153	0.010	0.167	4	PARA	YES	1x1-1	4-HIGH
155	0.010	0.167	2	PARA	NONE	1x1-1	4-HIGH
157	0.010	0.167	2	PARA	NONE	1x1-1	8-LOW
159	0.010	0.167	2	PARA	NONE	1x1-1	4-LOW
163	0.010	0.167	4	PARA	YES	1x1-1	8-HIGH
167	0.010	0.167	4	PARA	YES	1x1-2	8-HIGH
171	0.010	0.167	4	PARA	YES	1x1-2	4-HIGH
173	0.010	0.167	2	PARA	NONE	1x1-2	4-HIGH
175	0.010	0.167	2	PARA	NONE	1x1-2	8-HIGH
177	0.010	0.167	2	PARA	NONE	1x1-1	8-HIGH
181	0.010	0.167	4	PARA	YES	1x1-2	4-LOW
185	0.010	0.167	4	PARA	YES	1x1-2	8-LOW
187	0.010	0.167	2	PARA	NONE	1x1-2	8-LOW
189	0.010	0.167	2	PARA	NONE	1x1-2	4-LOW
193	0.020	0.167	4	PARA	YES	1x1-2	4-LOW
197	0.020	0.167	4	PARA	YES	1x1-2	8-LOW
200	0.020	0.167	3	PARA-REAR	YES	1x1-1	4-LOW
203	0.020	0.167	3	PARA-REAR	YES	1x1-1	8-LOW
206	0.020	0.167	3	PARA	YES	1x1-1	4-LOW
210	0.020	0.167	4	PARA	YES	1x1-1	8-LOW

Continued on next page

Table 2: Type-H Experiments — Continued

EX_ID	S_0	S_C	PUMP	GRATE	BLK	INLET	OUTLET
212	0.020	0.167	2	PARA	NONE	1x1-1	8-LOW
216	0.020	0.167	4	PARA	NONE	1x1-2	4-LOW
218	0.020	0.167	2	PARA	NONE	1x1-2	8-LOW
222	0.020	0.167	4	PARA	YES	1x1-2	8-HIGH
228	0.020	0.167	6	PARA	YES	1x1-1	4-HIGH
232	0.020	0.167	4	PARA	YES	1x1-1	8-HIGH
234	0.020	0.167	2	PARA	NONE	1x1-1	8-HIGH
236	0.020	0.167	2	PARA	NONE	1x1-1	4-HIGH
238	0.020	0.167	2	PARA	NONE	1x1-2	4-HIGH
240	0.020	0.167	2	PARA	NONE	1x1-2	8-HIGH
244	0.020	0.167	4	LID	YES	2x2-1	8-LOW
248	0.020	0.167	4	PARA	YES	2x2-1	8-LOW
252	0.020	0.167	4	PARA	YES	2x2-1	12-LOW
256	0.020	0.167	4	LID	YES	2x2-1	12-LOW
259	0.020	0.167	3	LID	YES	2x2-1	4-LOW
262	0.020	0.167	3	PARA	YES	2x2-1	4-LOW
264	0.020	0.167	2	PARA	NONE	2x2-1	4-LOW
266	0.020	0.167	2	PARA	NONE	2x2-1	8-LOW
268	0.020	0.167	2	PARA	NONE	2x2-1	12-LOW
270	0.020	0.167	2	PARA	YES	2x4-1	12-LOW
274	0.020	0.167	4	PARA	YES	2x4-1	4-LOW

3.4 Instrumentation

This section documents the instruments used and the measured and computed values obtained from this research. In general the targeted values were reported as in similar studies described in the literature review. Principal to the research is the measurement of velocity, depth, and flow width; discharge in the Texas Tech experiments (as in most of the reported experiments in the literature) was a computed value.

3.4.1 Flow Depth and Flow Width Measurement

Flow depth is a directly observable variable in the open channel portion of the model and in the outlet collection pipe, but unobservable in the inlet structure itself.⁸ Flow depth was used in conjunction with section geometry to determine flow area so that the product of flow area and velocity was the discharge at the section.

⁸Placement of a camera within the inlet was considered as technologically feasible, but beyond current equipment inventory.

The instruments used in this research were primarily staff gages directly read by the researchers. Staff gages are simply ruled markings on a shaft that allow a direct depth reading. Several of these were used in the model. Both USGS staff gages (readable to 0.01 feet precision), and hand-ruled gages were used. A plumb bob and staff gage was fabricated for measuring distance to channel and distance to water, the difference being the flow depth. Most of the depth measurements reported in Appendix III were the result of this fabricated staff gage.

Flow depth was measured at several sections upstream of the inlet model, at an overflow section, and in the outlet collector pipe. In the channel and overflow section the depth was measured at 5 to 7 stations along the section to account for the variable depths across the section. Flow width was computed from the difference in location of the left-edge of water using the flume wall as the datum and the right-edge of water. The flow width was required to determine the flow area from the channel geometry. In the overflow channel, the flow width was a constant 2 ft.⁹

The data reported in Appendix III were prepared from the raw measurements using spatial averaging so the reported approach depth was an average of three section depths which themselves were an average of 5 station depths. The overflow depths were temporal averages of three sets of cross section depths (each overflow section was measured three times for each experimental configuration). Figure 17 is an image showing one of the staff gages during the developmental stage of the experimental program — later this gage was removed from the channel side and extended from a bridge across the channel to measure depth to water for flow depth determination.

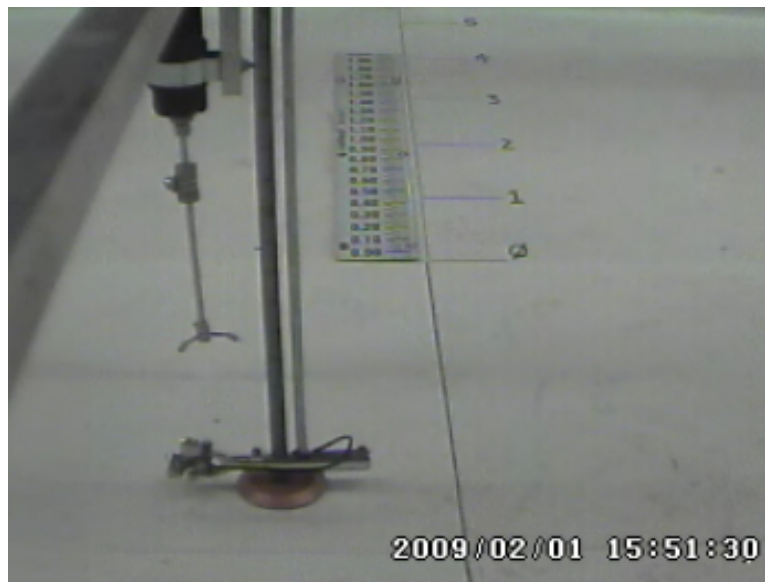

Figure 17: Image of a staff gage (attached to the sloped part of the channel), a pygmy-type current meter, and an acoustic doppler velocimeter

⁹The overflow channel was a 2-foot wide rectangular channel.

3.4.2 Velocity Measurement

Measurement of velocity was crucial to the overall experimental program. The velocity was used to compute discharges based on depth and area. These values (depth and area) were relatively straightforward to determine, depth by direct observation and area by geometry. Several velocity tools were used; in this section the tools are briefly discussed. Multiple techniques were desirable as an implicit back-up procedure for the times when primary instruments were not functioning.¹⁰

The three tools employed, in order of perceived sophistication were the following.

1. Drift Tracers: Drift tracers are small materials released into the flow, and the surface velocity was determined by analysis of the video imaging system to determine the time a tracer required to travel a fixed distance.¹¹ The hardware for the system was comprised of an end-user-built PC computer and ancillary equipment (DVR cards and cameras).



Figure 18: Swann C500 CCD Camera during system maintenance

Figure 18 is an image of one of the cameras. The camera has three adjustments on the lens system: an iris adjustment (middle ring), a crude focus, and a wide angle-telephoto adjustment. The three adjustments were interdependent and obtaining a sharp focus was a tedious trial-and-error process.

The imaging system captured images at 30 frames per second. An analyst can resolve about one-half inch movement in the video playback, thus the analyst can estimate velocities in the range of nearly zero to nearly 11 feet-per-second.¹²

¹⁰The multiple techniques were invaluable in this respect; during the summer of 2009 the researchers repaired the pygmy meter heads dozens of times, and had ADV failures that were undetected until after the experiments were completed. The drift tracer files were a valuable backup!

¹¹A time-of-flight measurement.

¹²This upper limit was an estimate of the analyst being able to find a tracer just as it entered the image frame and 1/30 a second later locating the tracer somewhere within the image frame. The image frame was marked with an 18-inch long grid and this estimate was assuming a 4.5-inch traverse can be identified. If a 9-inch traverse could be identified the upper limit was 22 feet per second; a value rarely observed.

2. Pygmy Current Meter: The pygmy current meter is a small size Price-type current meter. It uses a small rotor of horizontally mounted cups that turn a cam¹³. The cam contacts a whisker wire once per revolution closing a circuit. A digital counter counts the closings over a user specified time interval. The number of counts per time (revolutions per second) is converted into a velocity by a calibration chart. These instruments are considered rugged and reliable. At the time of this research, two such instruments were used. These instruments were used in flows too shallow for the acoustic instrument. These instruments are known to under-report velocity; rather than adjust velocities, the values as reported were used, but under-reporting bias is understood to be a potential source of uncertainty.
3. Acoustic Doppler Velocimeter: The acoustic Doppler velocity (ADV) instrument uses sound waves and the Doppler principle to detect frequency shifts (in the emitted sound) and from these frequency shifts and a correlation function determines the 3-dimensional velocity at a point in fluid flow. Four such instruments were on-hand.¹⁴ The meter head is the instrument in the middle of the image in Figure 17 and has three “fingers” extending from the vertical shaft. These “fingers” are the sound transducers that generate the signal detected by the instrument. The other three ADV instruments used in the research are similar in construction, but slightly larger. Three purpose-built computers were used to program and download velocity information from these instruments.

The researchers considered ADV measurements that passed the manufacturer’s internal QA/QC tests (part of the instrument’s software) as the most accurate measurement of velocity in the research. In very shallow flows, which were a substantial part of the work, these instruments would generate undesirable signal-to-noise ratio values; in such cases the researchers would reacquire the reading and if that failed, then the warning would be suppressed and used in the research. The ADV probes could consistently measure in 0.15-ft deep flow and sometimes could be pushed to shallower flows. The pygmy instrument could, with difficulty, be operated in as little as 0.10-ft deep flow. Shallower flows were measured using drift tracers.

3.4.3 Discharge Computation

The discharge was a computed value in this research. The most accurate gravimetric measurement techniques¹⁵ were not feasible for this study so less accurate methods were employed.

1. Velocity-Area: The method computes discharge as the product of flow area (determined from depth and geometry) and the mean section velocity, a measured value. In the case of an ADV measurement, the instrument itself computes discharge. In this research the ADV determined value was considered the most accurate. The pygmy-meter and drift tracer determined discharges were considered less accurate, but none the less were used to determine discharges in flow regimes where the ADV will not function.

¹³The meter head is the instrument closest to the photographer in Figure 17.

¹⁴The Water Science Center of the U.S. Geological Survey loaned an instrument for the 2009 portion of this research, along with guidance on using ADV instruments.

¹⁵Weighing water over a fixed time interval, or time to fill a known volume.

2. Weir Equations: Several locations in the experiments have known critical depth conditions, such as the inlet chute and overflow weir. Weir equations were used to supplement other methods.

4 Research Results

This section presents the research results from the Texas Tech experiments. The Texas Tech experimental results are tabulated in Appendix III. The results represent triplicate experiments for over 270 different configurations.¹⁶

4.1 TTU Results Compared to Prior (Literature-Derived) Work

The TTU results are rendered in comparative plots with literature-derived data to determine if the experimental results from Texas Tech were reasonably comparable to results from prior research. The anticipation was that the newer results should fall roughly within the same region of response space as the prior work, and vastly different results would be alarming. The principal variables that were considered are the approach and inlet discharges, approach depth, approach Froude number, as well as the length and depth ratios as per Cassidy (1966). These sets of values were considered in distinct plots in the following subsections.

4.1.1 Relationship of Approach Discharge and Capture Discharge

Figure 19 is a plot of the relation between the approach discharge and the inlet capture for the literature-derived data as well as the Texas Tech experiments. The solid gray markers are the literature-derived data; the cross-hair markers are experimental results. The literature derived data extend beyond the range plotted, however these data [not displayed] all plotted on the equal-value line, thus represent complete capture $Q_{inlet} = Q_{approach}$. A substantial portion of the literature derived database was for prior experiments in full sump conditions where the experiments were designed to achieve full capture.

In the lower left hand corner of the plot, where partial capture was reported in the literature, the agreement between the Texas Tech experiments and the literature results is good. This result was anticipated. The researchers believe any other result would have indicated some kind of measurement error; despite the considerable uncertainty reported in the methods section, this result was reassuring.

The equal-value line in the plot is the best performance line that any inlet could achieve and it (the line) represents full capture. The reader is reminded that this plot is presented without regard to inlet type, grate orientation, channel slope, and so forth. This plot illustrates that the experimental design provided results that are consistent with prior studies in terms of approach and capture magnitudes in the range of flow where incomplete capture was reported.

¹⁶A configuration in this report is some single combination of approach flow, longitudinal slope, inlet type, grate orientation, outlet restrictor elevation, and ditch block setting.

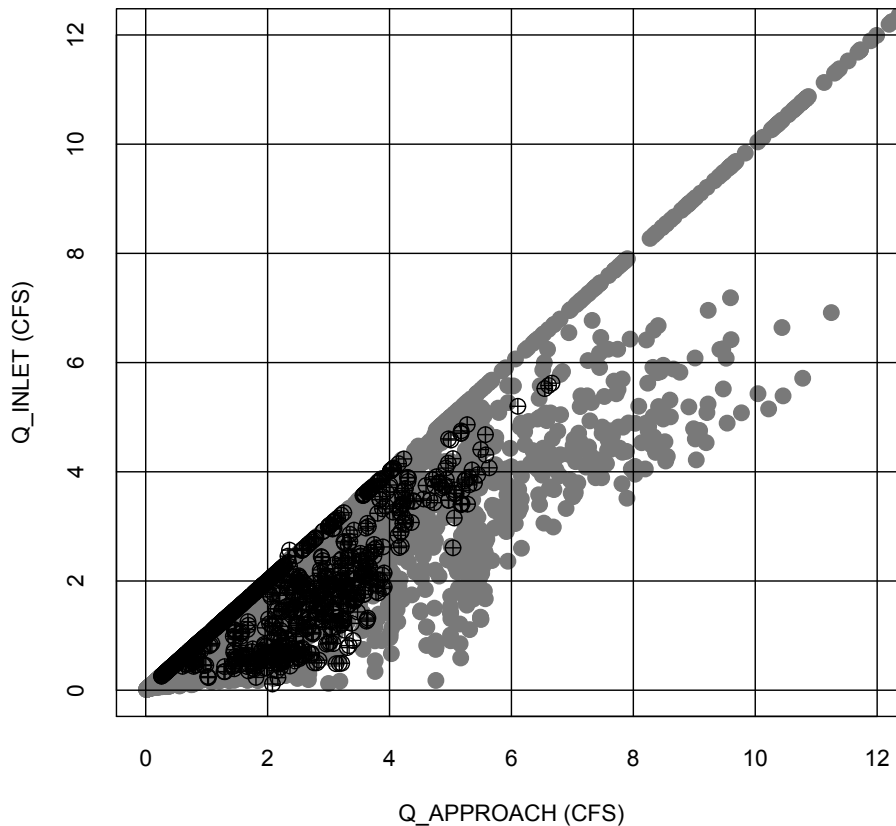

Figure 19: Relationship of TTU Experimental Approach and Inlet Flows (dark, crosshair) and Literature-Derived Approach and Inlet Flows (light grey).

4.1.2 Relationship of Approach Depth and Capture Discharge

The approach depth in the Texas Tech experiments was the spatial and temporal arithmetic mean of depths measured at three sections upstream of the inlet model and three or more different times during each experimental configuration. The literature values were either directly reported depths or computed depths from other descriptive information contained in the pertinent reports.

Figure 20 is a plot of the approach depth and the flow captured by the inlet. The Texas Tech results populated about the same portion of the chart as the prior studies, with several important considerations.

1. TTU data contained results both with and without a ditch block, and for several inlet sizes. This consideration explains the string of markers that extends to a depth of 0.6 feet with

comparatively small capture. Of additional note, the ditch block was 0.5 feet high in the TTU model, yet the approach depth (because of the depth taper in a sloped channel) was less than this value in all the experiments.

2. The literature-derived results contained several relatively smooth relationships, which leads the researchers to speculate that they inadvertently digitized design charts thinking the charts actually represented experimental results.
3. The TTU instruments could not measure velocity (and hence discharge) at the lowest depths represented in the chart, again suggesting that the TTU researchers inadvertently “extended” the prior data.

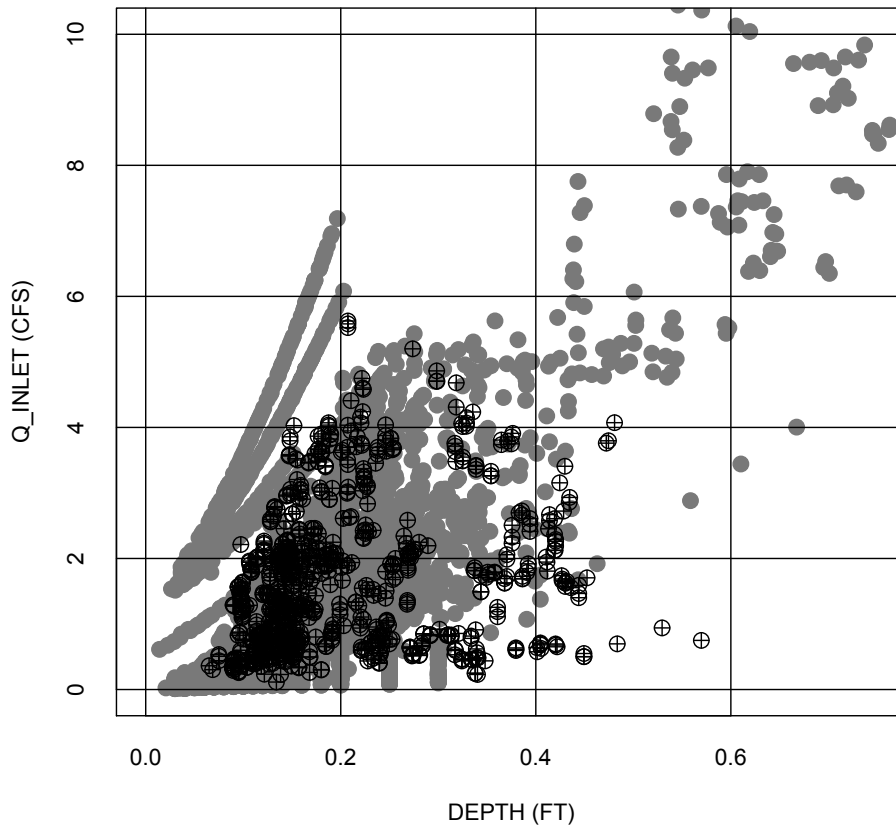

Figure 20: Relationship of TTU Experimental Approach Depth and Inlet Flow (dark, crosshair) and Literature-Derived Approach Depth and Inlet Flow (light grey).

Figure 20 and the next several comparative figures exhibit an appearance that suggests that inlet capacity is unpredictable, however these figures are only showing a single explanatory variable and

there was no anticipation that a single variable would suffice as a performance predictor. The purpose of these figures is to demonstrate that the experimental results are consistent with prior experiments for morphologically similar conditions.

4.1.3 Relationship of Approach Froude Number and Capture Discharge

The Froude number was perceived by the researchers to be a valuable dimensionless parameter for performance prediction based in part on its appearance in some of the earlier studies in the literature, particularly Cassidy (1966).

Figure 21 is a two-panel plot of the relationship between the approach Froude number and the inlet capture discharge, without regard to inlet configuration, channel slope, and other adjustable physical characteristics. As with the other plots in this section, its purpose is to illustrate where the TTU experiments fall in the context of prior work.

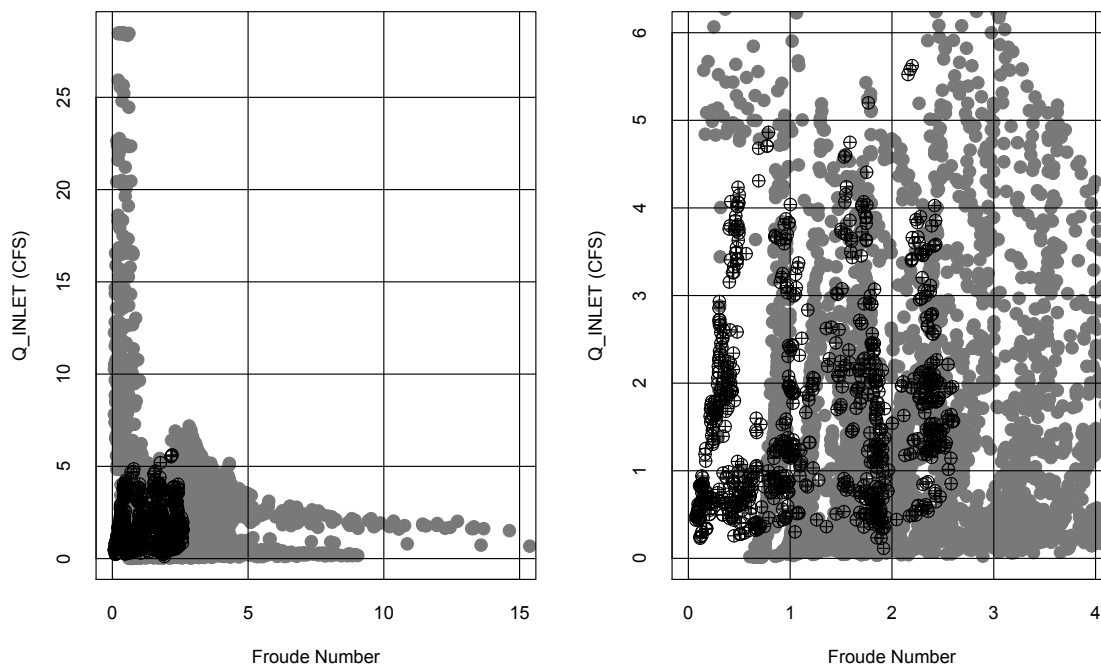

Figure 21: Relationship of TTU Experimental Approach Froude Number and Inlet Flow (dark, crosshair) and Literature-Derived Approach Froude Number and Inlet Flow (light grey).

In the left panel, the TTU experiments essentially populate the lower left hand corner of the plot, while the right panel is a closer view of the region of the Texas Tech results. The plot is suggestive of the following considerations.

1. The relatively low values of inlet capture for a large range of Fr (the horizontal markers near $Q_i=0$, for the prior studies was a consequence of flows at very shallow depths where substantial splash-over was present, and there was no nearby ditch-block. Many of the prior studies of either curb-type inlets or slot-inlets would populate this region of the plot.
2. The nearly vertical trace of markers near $Fr < 2.0$ are the results from the three FHWA full-scale experiments with drop inlets in sag configuration. Unique to those experiments were comparatively deep water depths above the inlets.
3. The vertical “bands” in both the TTU experiments (right panel of the plot) and the literature-derived results are representative of individual experimental conditions for different inlet types. In the TTU experiments, a portion of the marker cloud plots comparatively flat; these are the no-ditch-block experiments, where capture of the flow is anticipated to be relatively poor anyway, and the behavior mimics the structure of the prior studies.

4.1.4 Relationship of Approach Length Ratio and Approach Depth Ratio and Capture Discharge

In Cassidy (1966), a relative length and depth ratio were defined and used as data reduction variables (non-dimensional ratios used to plot results). The depth ratio, as defined in Cassidy (1966), was the ratio of inlet length along the flow axis to approach flow depth; the width ratio was the ratio of approach flow depth to inlet width transverse to the flow axis. The product of the two values for any experiment should recover the aspect ratio of the inlet (i.e. L/W). Figure 22 is a plot of the relationship of the depth ratio and inlet capture (left panel) and the length ratio and inlet capture (right panel). In both panels the Texas Tech results are reasonably consistent with the studies reflected in the literature-derived database, in both location on the plots as well as in overall pattern in the two plots.

Based on these comparative plots with literature-derived data, the experimental results from Texas Tech were reasonably comparable to results from prior research. Some important distinctions exist, in particular the TTU results were for shallow flows, and hence represent results that are appropriate only for such flows. The researchers believe that these shallow flow results are of value in transportation infrastructure because of the nature of the drainage challenge and that comparatively deep flows are not the intent of such structures.¹⁷

4.2 TTU Exploratory Data Analysis

This subsection presents selected exploratory data analysis of the Texas Tech experimental results.

¹⁷The researchers acknowledge that deep flows are surely common in transportation drainage, but as a practical matter these deep behavior were not explored in the present experiments, and were explored in prior work for three configurations.

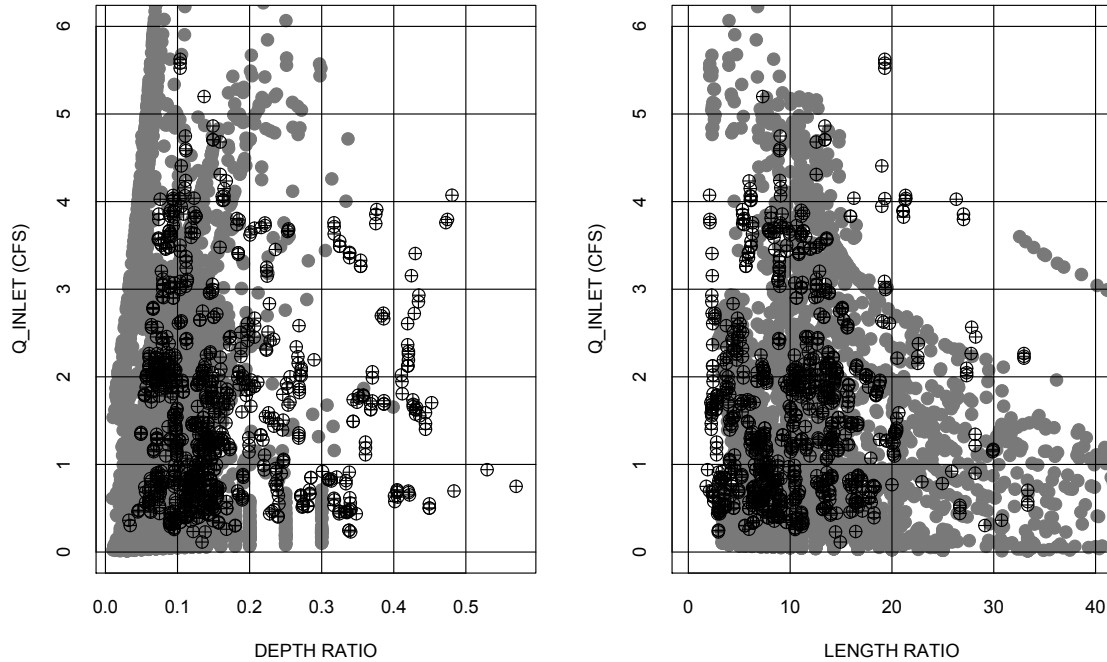

Figure 22: Relationship of TTU Experimental Approach Length Ratio and Inlet Flow (dark, crosshair) and Literature-Derived Approach Length Ratio and Inlet Flow (light grey).

4.2.1 Grated and Un-grated Inlets

A subset of the TTU experiments were performed in an open-hole configuration. These experiments were comparatively few as compared to configurations with inlet grates, in part because an open hole is not a configuration that would be encountered in practice.

Figure 23 is a plot of the relationship of approach discharge and capture for the experiments that were comparable.¹⁸ A Wilcoxon Signed-Rank test produced p-values at rejection that indicated that the approach discharges are indistinguishable in either configuration (an anticipated finding) and that the capture discharges were also indistinguishable (an unanticipated finding). Thus the researchers concluded that differences in performance for grated and non-grated inlets were not statistically significant.

Based upon review of video capture of the experiments the researchers were of the opinion that in shallow flow, grates actually improve inlet performance by providing some measure of vortex control. In the larger depth open-hole experiments, an obvious gyre (rotational flow structure)

¹⁸By comparable, the authors mean that the configuration were the same inlet model dimension, longitudinal slope, and only differed by the presence or absence of a grate. Tandem configurations were never run “open-hole” nor were 2-foot X 2-foot inlets.

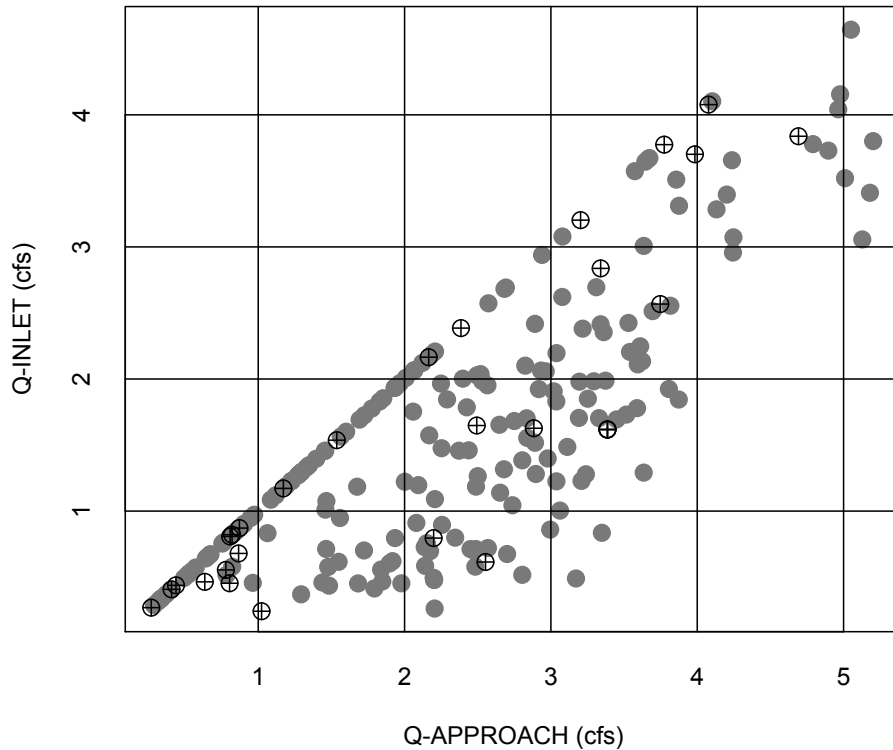

Figure 23: TTU Experimental Results for Comparable Experiments using an inlet without (dark, crosshair) and with (light grey) grate.

developed and was sustained for long intervals (on the order of minutes). An inlet grate in the same experimental conditions exhibited a less pronounced gyre, and the rotational structure was unstable. In both cases there was a periodic behavior that the researchers think is the result of air in the outlet structure being trapped then released.¹⁹

The researchers abandoned open-hole experiments during the study in a response to limited time remaining to complete other aspects of the research.

4.2.2 Sump and By-Pass Conditions

All the TTU configurations included at least two discharge cases where the ditch block was removed, representing the situation where the inlet was an intermediate inlet and not a terminal (sump

¹⁹This phenomenon is thought to be similar to the pulsing flow in a culvert where at the inlet side the culvert becomes repeatedly submerged then unsubmerged while the tailwater is relatively constant and unsubmerged.

condition) inlet. The anticipation was that sump (ditch-block) conditions were the more likely practical application of a Type-H inlet, while the intermediate inlet was also a possibility.

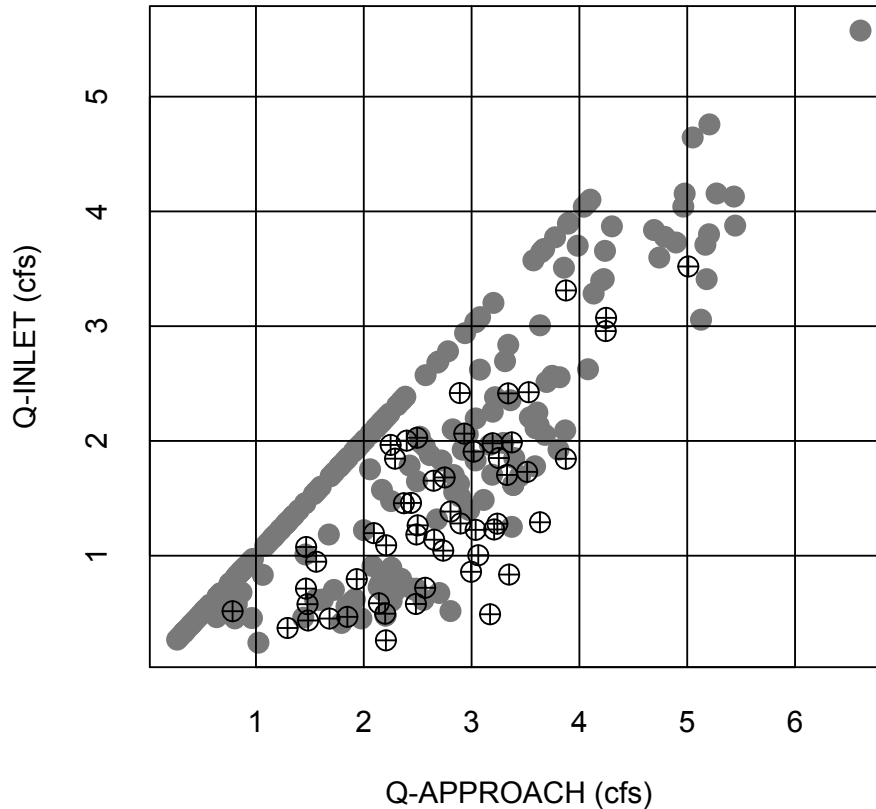

Figure 24: TTU Experimental Results for Sump/Ditch Block (light grey) and By-Pass/No Block (dark, crosshair) conditions. This plot includes results from single-inlet, tandem-inlet, and lid-type inlet experiments.

Figure 24 is a plot of the sump and by-pass experiments. As indicated in the plot, none of the bypass experiments could achieve complete capture (that is there was always some overflow), while the sump conditions in many experiments did achieve complete capture.

A Wilcoxon Signed-Rank test produced p-values at rejection that indicate that the capture discharges were different, and smaller in the by-pass (No Block) condition. This finding was anticipated and important because if the inlets were used in a by-pass condition, but if sump condition performance is the design basis, substantial under-performance will result.

Figure 25 displays additional information for sump conditions by considering longitudinal slope.

The light grey markers correspond to the experiments that are in sump condition. In this figure, moving clockwise, the results are plotted collectively then by each slope. In the sump conditions, about one-half of the cases produced complete capture.²⁰ By design, the researchers forced cases where the inlet would be unable to capture all the discharge. These experiments are important in establishing some design guidance later in the report.

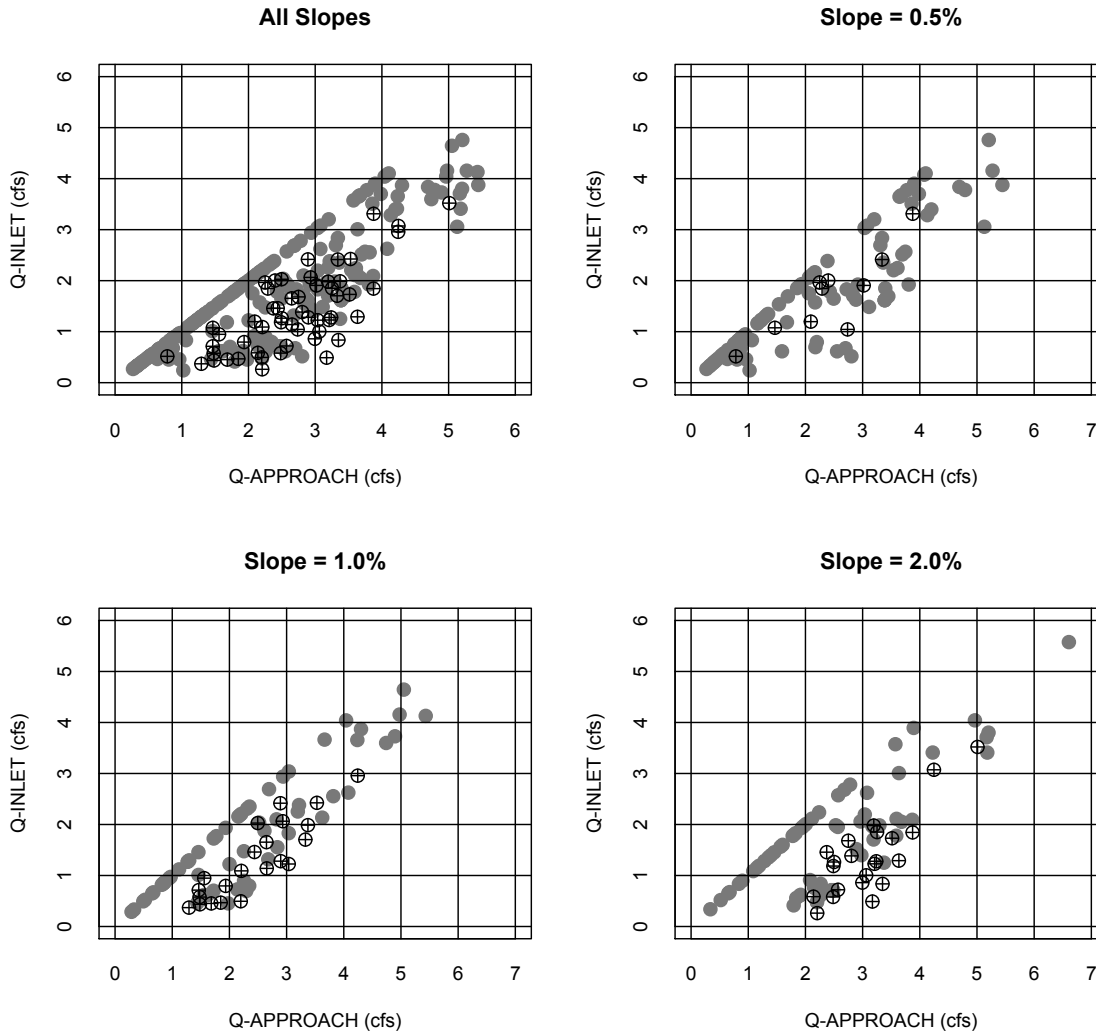

Figure 25: TTU Experimental Results for Sump/Ditch Block (light grey) conditions and By-Pass/No Block (dark, crosshair), segregated by longitudinal slope. These plots include single-inlet, tandem-inlet, and lid-type inlet experiments.

Figure 25 also presents results without a ditch block, the by-pass configuration. As anticipated, in these experiments the inlet never achieved complete capture. Additionally, although subtle,

²⁰Complete capture is the point of sump conditions, so this finding was anticipated

the plots suggest that as slope increased the capture ratio degraded. The marker cloud moves away from the equal value line at larger slope. In the sump conditions this phenomenon was not observed, however this lack of slope sensitivity could very well be an experimental artifact because the overflow portion of the model was quite short.²¹

²¹In the overflow region after the ditch block, the distance is less than 6 feet to the measurement location. The block is functioning as a weir and flow was very turbulent and unstable in these experiments.

4.2.3 Inlet Configurations

The various inlet configurations used in the TTU studies corresponded to inlet plan-view areas of 1-ft², 2-ft² and 4-ft² on inlet area. The inlets were all square, so these respective configurations also corresponded to inlet perimeters of 4, 8, and 8 feet.

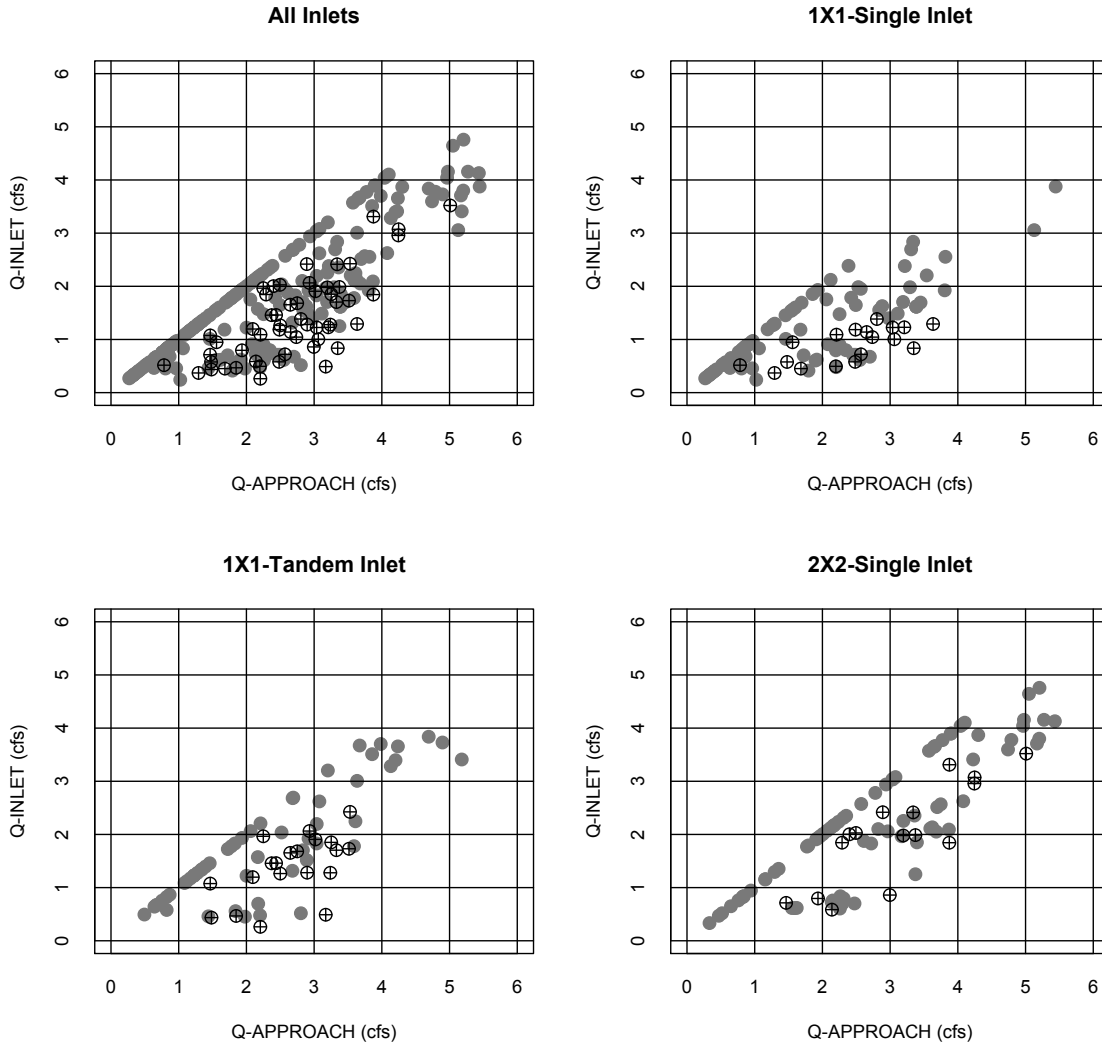

Figure 26: TTU Experimental Results for Sump/Ditch Block (light grey) conditions and By-Pass/No Block (dark, crosshair), segregated by inlet dimension. These plots include single-inlet, tandem-inlet, and lid-type inlet experiments.

A set of comparative plots is shown in Figure 26 for both by-pass and sump conditions. This set of plots is important because the plots demonstrate increased capture discharge as the inlet size increased, an anticipated and intuitive result.

Figure 27 is a subset of Figure 26 that displays the lid-type inlet performance as compared to the same size grate type inlet models. These experiments were all conducted in sump conditions.

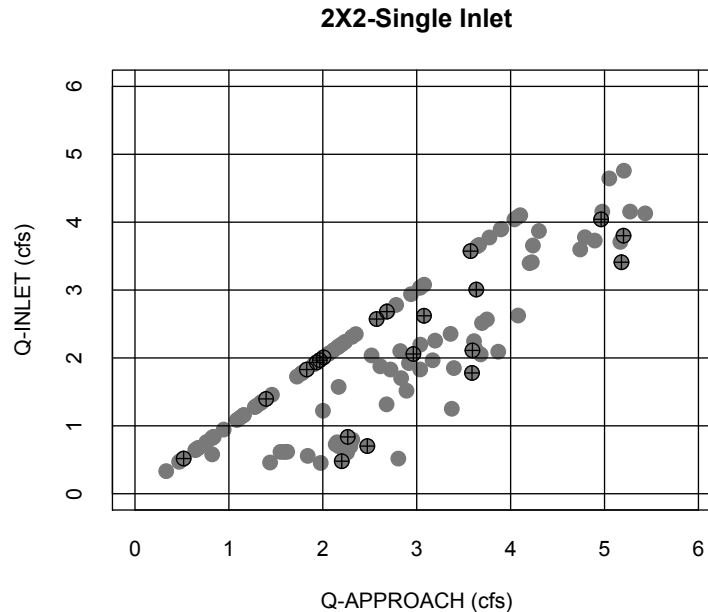

Figure 27: TTU Experimental Results for Sump/Ditch Block conditions 2X2 inlet dimension and lid-type 2X2 inlets (dark, crosshair). This figure shows single-inlet, and lid-type inlet experiments.

4.3 Results Summary

The results from the Texas Tech experiments were consistent with similar experimental results from the literature examined in this study. The TTU results, when examined in an exploratory fashion suggest the following conclusions.

1. The dimensionless groups suggested by Cassidy (1966) when plotted on selected axes produced patterns similar to that of the prior literature; this result is desirable.
2. Any single dimensionless ratio suggested by Cassidy (1966) does not confer ability to predict performance; inlet behavior is a complicated interaction of multiple dimensionless ratios (i.e. multiple simultaneous dimensions would need to be plotted to detect a pattern).
3. The presence or absence of a grate in the inlet model cannot be detected from the data, so the decision to abandon “open-hole” experiments in the interest of time was justified.
4. The presence or absence of a ditch block (sump or by-pass conditions) has an effect on inlet

performance, an anticipated and also intuitive result.

5. The longitudinal slope appeared to have some effect on inlet capture performance, so the speculation that this variable was important (in contrast to Cassidy (1966) who stated the opposite²²) was confirmed.
6. Tandem inlets did not appear to have any special performance advantage; their results seem to scale simply with the increased inlet area.
7. The lid-type inlets performed comparably to their grate-type morphological analogs. The lid-type did not appear to have a detrimental effect on performance.
8. The inlet dimension (size) also had an effect on the capture performance. This finding was crucial in suggesting design procedures for Type-H inlets and similar drop inlets.

²²In defense of the prior work, they used supercritical flow forced under a sluice gate — in the dimensions of their study, slope being meaningless is quite understandable.

5 Data Analysis and Interpretation

This section presents interpretation of the TTU experiments in the context of performance prediction using several approaches. The HEC-22 design procedure for median inlets was applied using the dimensions of the Texas Tech experiments to determine if HEC-22, without adjustment, predicts the observed behavior. Functional relationships as suggested by the earlier work of Cassidy (1966) and Larson (1948) were developed using power-law models and regression analysis.

5.1 Analysis of TTU Experiments using HEC-22 Methodology

Chapter 4 of the FHWA HEC-22 manual presents a variety of design considerations for drainage inlets. The considerations most appropriate to the Type-H configuration appear in two sections:

1. (4.4.5) Interception Capacity of Inlets in Sag Locations. This section of HEC-22 states

“A grate inlet in a sag location operates as a weir to depths dependent on the size of the grate and as an orifice at greater depths. Grates of larger dimension will operate as weirs to greater depths than smaller grates.”

Later in the section, equations are provided for the weir condition and the orifice condition. Compared to the procedure for median and roadside ditch inlets (below), the computations involved for sag location application are relatively simple.

2. (4.4.7.1) Median and Roadside Ditch Inlets. This section of HEC-22 contains guidance in the form of design charts and equations for determining the fraction of flow intercepted by an inlet in a ditch. Of some importance, the current copy of HEC-22 contains a typographic error in equation 4-37; however the charts can be used instead (and in fact are needed for part of the computations anyway) and do not appear to be in error.

5.1.1 TTU configurations as Sag Location Inlets

The TTU experiments were conducted as sag inlets (using a ditch block) and as overflow inlets (without the ditch block). In this subsection, the sag-type results are examined. The TTU geometry was known and discharges and depths were measured. The HEC-22 methodology for design would require the engineer to determine the discharge approaching the inlet, and from that discharge and known geometry determine a flow depth.

The flow depth is determined by solving Manning’s equation (Equation 2) for the unknown depth required to match the discharge. In this process, the longitudinal slope of the bed (channel, gutter, etc.) is used as the friction slope in Manning’s equation.

$$Q = \frac{1.49}{n} AR_h^{2/3} S_f^{1/2} \quad (2)$$

The depth d is a component of both the flow area, A , and the hydraulic radius, R_h .

The weir condition would then compute the capture discharge from Equation 3, which is an adaptation of Equation (4-26) in the HEC-22 manual:

$$Q_i = C_w P d^{3/2} \quad (3)$$

where $C_w = 3.0$ is a weir coefficient in U.S. Customary units, P is the weir perimeter (a length), and d is the flow depth.

The orifice condition, intended for deeper flows would determine inlet capture according to Equation 4, which is an adaptation of Equation (4-27) in the HEC-22 manual.

$$Q_i = C_o A_i \sqrt{2gd} \quad (4)$$

where $C_o = 0.67$ is an orifice coefficient, A_i is the inlet area, d is the flow depth.

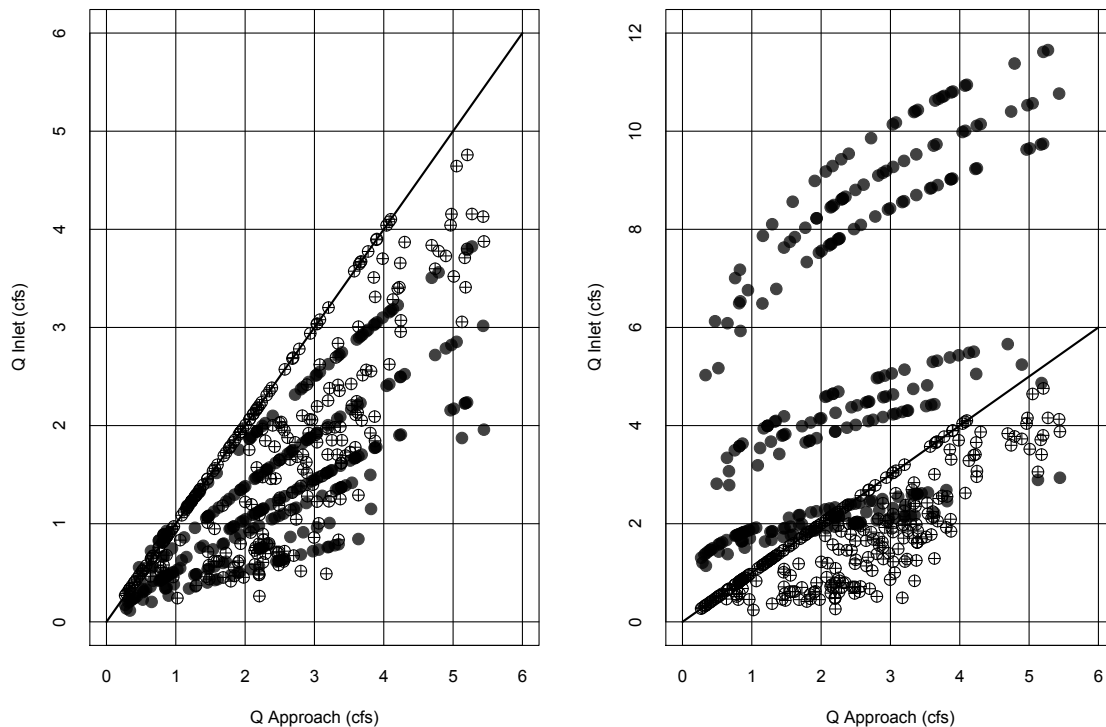

Figure 28: Relationship of approach discharge and inlet capture discharge for the Texas Tech experiments (cross-hair markers) and HEC-22 predicted performance (solid markers) using the weir equation (left panel) and a submerged orifice equation (right panel).

Figure 28 is a plot of predicted performance using the weir condition and the orifice condition,

using depths computed from Manning's equation²³.

The left panel of Figure 28 is a plot of the observed approach flow and inlet capture flow from the TTU experiments (the cross-hair markers), and the corresponding predicted performance for the inlet using Equation 3 (the solid markers). The corresponding plot for Equation 4 appears as the right panel of the figure. Recalling that our experiments had weir perimeters of either 4.0 or 8.0 feet and areas of 1.0, 2.0, and 4.0 ft² the impact of area is quite apparent in the orifice results. The three distinct bands of markers correspond to the three distinct inlet sizes (yet the performance prediction using the orifice equation was unsuitable).

Figure 29 is the same information in the left panel of Figure 28, except the plots are broken into separate graphs based on the inlet model. In these plots, the upper left hand panel presents all the results without regard to inlet opening size, while the remaining three panels present the single 1X1 inlet, the tandem 1X1 inlet and the 2X2 inlet.

5.1.2 TTU configurations as Median (Non-Sag) Location Inlets

The TTU experiments were conducted as sag inlets (using a ditch block) and as overflow inlets (without the ditch block). In this subsection, the median-type results are examined. As in the previous subsection, the TTU geometry was known and discharges and depths were measured. As in the previous section, the HEC-22 methodology for design was applied to compare the predictive value of the HEC-22 methodology with the observed results in the laboratory.

Figure 30 is a set of comparative plots of observed (cross-hair markers) and predicted (solid markers) performance. In these plots the upper left hand panel presents all the results without regard to inlet opening size, while the remaining three panels present the single 1X1 inlet, the tandem 1X1 inlet and the 2X2 inlet. Although there were fewer experiments conducted in the overflow case, the results suggest that the weir formula is a reasonable performance estimator for this flow condition — a desirable finding.

The researchers conclude the following from these analyses:

1. The HEC-22 design guidance, specifically the weir-type approach of Equation (4-26) in the manual, without adjustment, approximates the behavior observed in the experimental studies at Texas Tech. This equation will tend to under-predict inlet capture performance thereby favoring inlet designs that are larger than necessary.
2. The orifice condition, Equation (4-27), was not replicated by the experimental conditions examined in this study. The researchers speculate that prior studies did not have outlet vault box flow restrictions, and perhaps this fundamental difference impacts the utility of the orifice equation for inlet design. Alternatively, the depth above an orifice may in fact need to be

²³Equation (4-37), corrected for the typographical error, in HEC-22 was used to determine the flow depths. $n = 0.009$ was used in these model computations to force a comparable result, the physical model is probably quite smooth in the context of Manning's roughness and this approximation is deemed appropriate for this report. If $n = 0.015$ is used, a value typical for smooth concrete, the solid-marker patterns would retain their shape but displace upward.

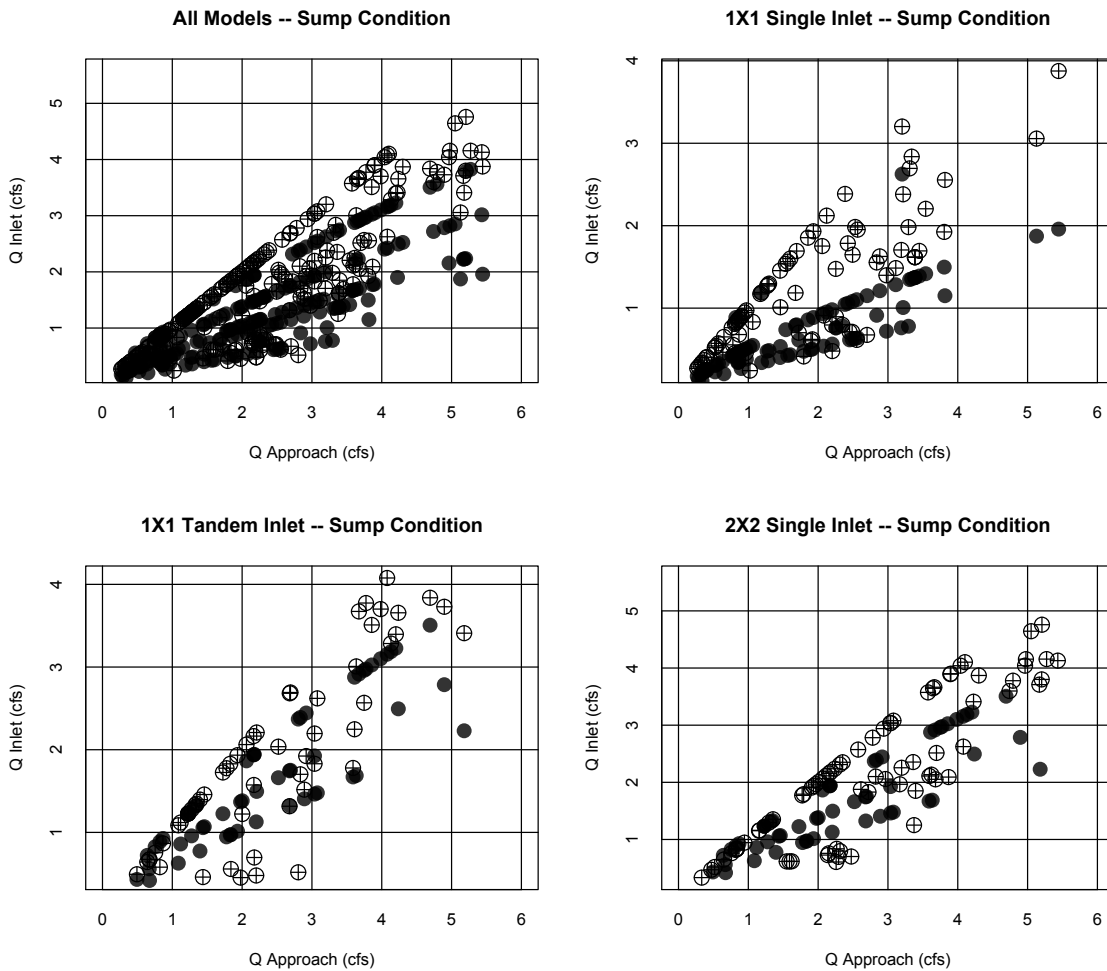

Figure 29: Relationship of approach discharge and inlet capture discharge for the Texas Tech experiments (cross-hair markers) and HEC-22 predicted performance (solid markers) using the weir equation, classified by inlet model type.

quite deep, on the order of several inlet diameter equivalents, before orifice-like flow actually occurs. Use of orifice conditions, when not appropriate will tend to over-predict inlet capture performance thereby favoring inlet designs that are smaller than necessary.

5.2 Analysis of TTU and Literature Derived Data using Power-Law Models

Cassidy (1966) and Larson (1948) used dimensional analysis to postulate functional relationships between dimensionless values and inlet performance. Cassidy (1966) presented Equation 5 for inlet

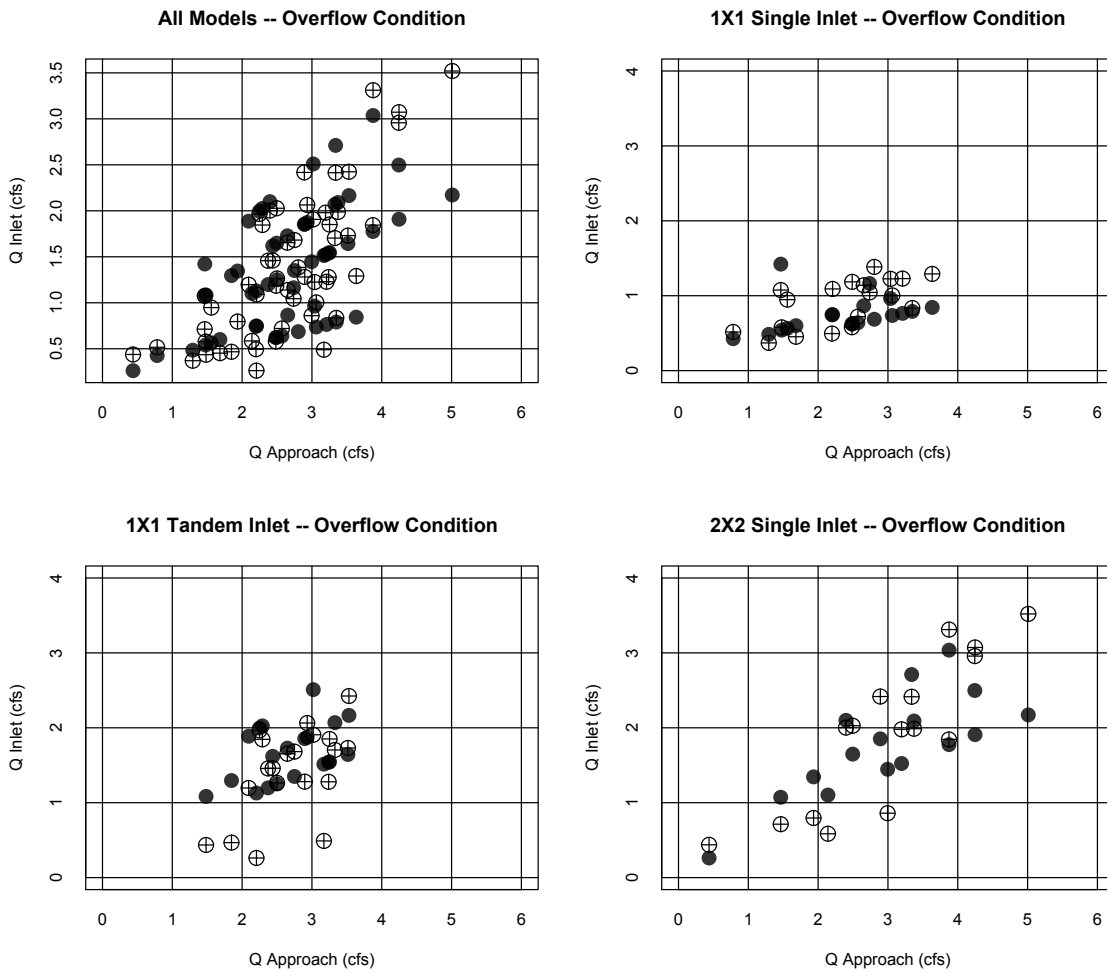

Figure 30: Relationship of approach discharge and inlet capture discharge for the Texas Tech experiments (cross-hair markers) and HEC-22 predicted performance (solid markers) using the weir equation, classified by inlet model type.

hydraulics:

$$\frac{Q_i}{Q_o} = \phi\left(\frac{V_o}{\sqrt{gD}}, \frac{L}{D}, \frac{D}{W}, S, S_0, \beta\right) \tag{5}$$

where Q_i is inlet discharge, Q_o is approach discharge, $\frac{V_o}{\sqrt{gD}}$ is approach Froude number, D is flow depth, L is inlet length, W is inlet width, S is side slope, S_0 is longitudinal slope, and β is a morphology index.

Of importance in the relationship is the various geometric ratios, slopes, the Froude number and the last term, β , which for all practical purposes is a morphology index to relate the geometric and hydraulic characteristics to different inlet types. Missing is of course the structural form of ϕ .

The current research team postulated that a power-law relationship was a usable functional form for ϕ , with some caveats. A power-law model, fitted to literature and/or experimental data is fundamentally empirical, and some dimensionless terms were omitted because they did not contribute prediction value (in particular slope).

After considerable exploratory analysis, the present work used the following power-law model structure for inlet performance:

$$Q_i = 10^{\beta_0} (Q_a)^{\beta_1} \left(\frac{V_o}{\sqrt{gD}}\right)^{\beta_2} \left(\frac{D}{W}\right)^{\beta_3} \left(\frac{L}{D}\right)^{\beta_4} \left(\frac{W}{L}\right)^{\beta_5} \quad (6)$$

where Q_i is inlet discharge, Q_a is approach discharge, $\frac{V_o}{\sqrt{gD}}$ is approach Froude number, D is flow depth, L is inlet length, W is inlet width, and β_i are regression exponents.

The right-most term of the expression is an aspect ratio (our version of a morphologic index) that for most of the Texas Tech experiments was unity. In the literature-derived data, slotted inlets were included in the database, thus this term takes on values much different than unity for those conditions.

There was no attempt at a unified theory per-se, but a power-law model that could be used to compare the prior and current work was deemed crucial to developing useful guidelines for inlet performance prediction. The unknown exponents β_i were determined by ordinary least squares regression on the logarithms of the original variables. Longitudinal slope was explicitly omitted; in a design problem the slope would enter in the velocity and depth specification.

The **R** statistical computing package was used to perform the regression analysis. Two distinct analyses were performed, the first used the entire literature-derived database to construct a model of inlet performance, then this model was used to predict the experimental behavior (an extrapolation). The second analysis performed the same sequence of tasks, but the Texas Tech experiments were used to construct a model of inlet performance and then these results were extrapolated to the literature-derived results.

5.2.1 Literature-Derived Data Model — Extrapolated to TTU Experiments

The relevant **R** commands for using the literature derived data to construct a power law model of inlet performance are listed below.

Call:

```
lm(formula = log10(Q_INLET[1:3918]) ~ log10(Q_APPROACH[1:3918]) +
    log10(FR[1:3918]) + log10(DEPTH_RATIO[1:3918]) + log10(W.L[1:3918]) +
    log10(LENGTH_RATIO[1:3918]))
```

Residuals:

Min	1Q	Median	3Q	Max
-0.94788	-0.08170	0.02512	0.10758	0.43556

Coefficients:

	Estimate	Std. Error	t value	Pr(> t)
(Intercept)	-0.616814	0.011343	-54.378	< 2e-16 ***
log10(Q_APPROACH[1:3918])	1.084075	0.005025	215.753	< 2e-16 ***
log10(FR[1:3918])	-0.337027	0.009179	-36.719	< 2e-16 ***
log10(DEPTH_RATIO[1:3918])	-0.171859	0.024652	-6.972	3.66e-12 ***
log10(W.L[1:3918])	0.195749	0.012972	15.090	< 2e-16 ***
log10(LENGTH_RATIO[1:3918])	0.322663	0.022125	14.584	< 2e-16 ***

Signif. codes: 0 *** 0.001 ** 0.01 * 0.05 . 0.1 1

Residual standard error: 0.1542 on 3912 degrees of freedom

Multiple R-squared: 0.9343, Adjusted R-squared: 0.9342

F-statistic: 1.113e+04 on 5 and 3912 DF, p-value: < 2.2e-16

The resulting inlet performance model is expressed in Equation 7.

$$Q_i = 10^{-0.616814} (Q_a)^{1.084075} \left(\frac{V_o}{\sqrt{gD}}\right)^{-0.337027} \left(\frac{D}{W}\right)^{-0.171859} \left(\frac{L}{D}\right)^{0.322663} \left(\frac{W}{L}\right)^{0.195749} \quad (7)$$

where Q_i is inlet discharge in cubic feet per second, Q_a is approach discharge in cubic feet per second, $\frac{V_a}{\sqrt{gD}}$ is approach Froude number, D is flow depth in feet, L is inlet length in feet, W is inlet width in feet. Of some importance is the inverse relationship with Froude number, an anticipated result; and an inverse relationship flow depth — a somewhat surprising result.

Figure 31 is a plot of the literature derived results (gray markers, upper panel) and the fitted values from Equation 7 (black markers upper panel), and the experimental values from the TTU experiments with results predicted using the literature-derived regression coefficients.

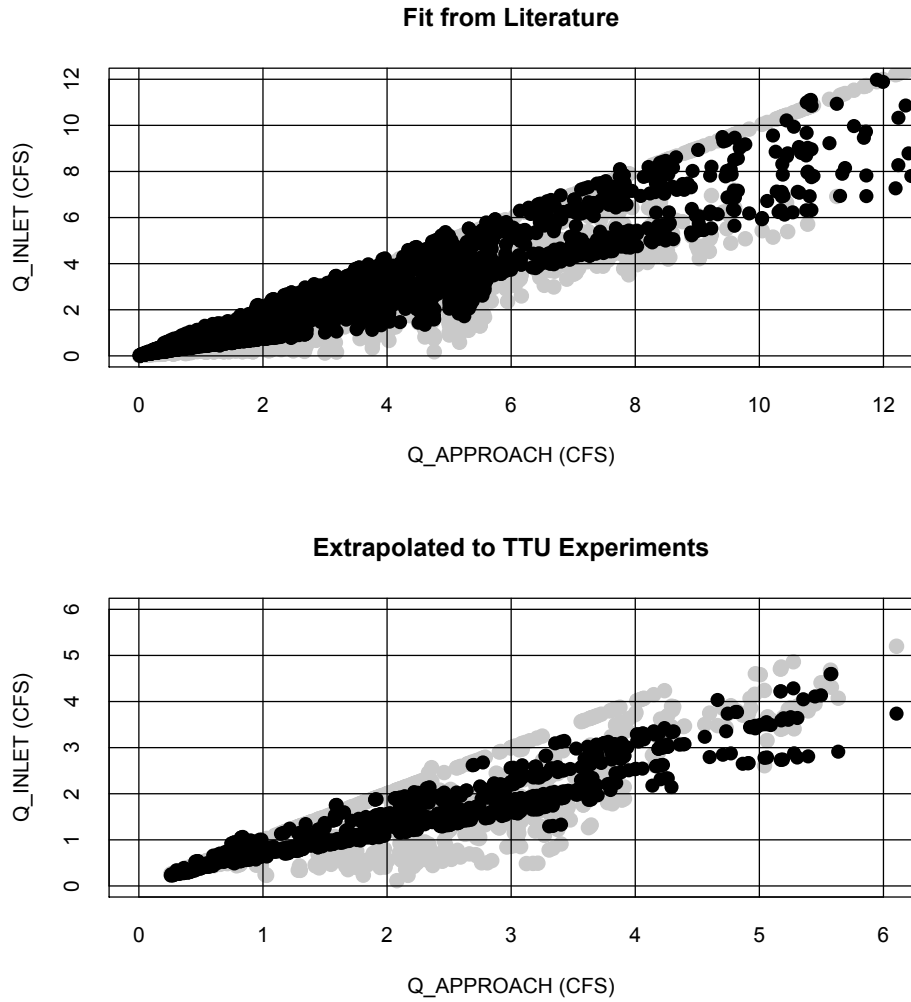

Figure 31: Upper Panel: Literature derived results (gray markers) and fitted performance model (black markers). Lower Panel: TTU experimental results (gray markers) and literature derived model applied to experimental conditions (black markers).

5.2.2 Experiment-Derived Data Model — Extrapolated to Literature Results

The relevant **R** commands for using the experimentally-derived data to construct a power law model of inlet performance are listed below.

Call:

```
lm(formula = log10(Q_INLET[3919:4737]) ~ log10(Q_APPROACH[3919:4737]) +
    log10(FR[3919:4737]) + log10(DEPTH_RATIO[3919:4737]) + log10(LENGTH_RATIO[3919:4737]))
```

Residuals:

	Min	1Q	Median	3Q	Max
	-1.05713	-0.06072	0.05123	0.14030	0.25314

Coefficients:

	Estimate	Std. Error	t value	Pr(> t)
(Intercept)	-0.50945	0.04721	-10.791	< 2e-16 ***
log10(Q_APPROACH[3919:4737])	0.94507	0.02945	32.085	< 2e-16 ***
log10(FR[3919:4737])	-0.20485	0.02964	-6.912	9.67e-12 ***
log10(DEPTH_RATIO[3919:4737])	-0.25183	0.06022	-4.182	3.20e-05 ***
log10(LENGTH_RATIO[3919:4737])	0.13817	0.04655	2.968	0.00308 **

Signif. codes: 0 *** 0.001 ** 0.01 * 0.05 . 0.1 1

Residual standard error: 0.1895 on 814 degrees of freedom

Multiple R-squared: 0.6194, Adjusted R-squared: 0.6175

F-statistic: 331.2 on 4 and 814 DF, p-value: < 2.2e-16

The resulting inlet performance model is expressed in Equation 8.

$$Q_i = 10^{-0.50945} (Q_a)^{0.94507} \left(\frac{V_a}{\sqrt{gD}}\right)^{-0.20485} \left(\frac{D}{W}\right)^{-0.25183} \left(\frac{L}{D}\right)^{0.13817} \left(\frac{W}{L}\right)^0 \quad (8)$$

where Q_i is inlet discharge in cubic feet per second, Q_a is approach discharge in cubic feet per second, $\frac{V_a}{\sqrt{gD}}$ is approach Froude number, D is flow depth in feet, L is inlet length in feet, W is inlet width in feet.

As with the previous case, the inverse relationship with the Froude number was an anticipated result; the loss of the aspect ratio as a predictive term was the result of the Texas Tech experiments having nearly all aspect ratios of unity.

Figure 32 is a plot of the TTU derived results (gray markers, upper panel) and the fitted values from Equation 8 (black markers upper panel), and the literature-derived values with results predicted using the TTU-derived regression coefficients.

Figures 31 and 32 convey similar information, that the power-law model appears to have utility as an inlet performance prediction tool.

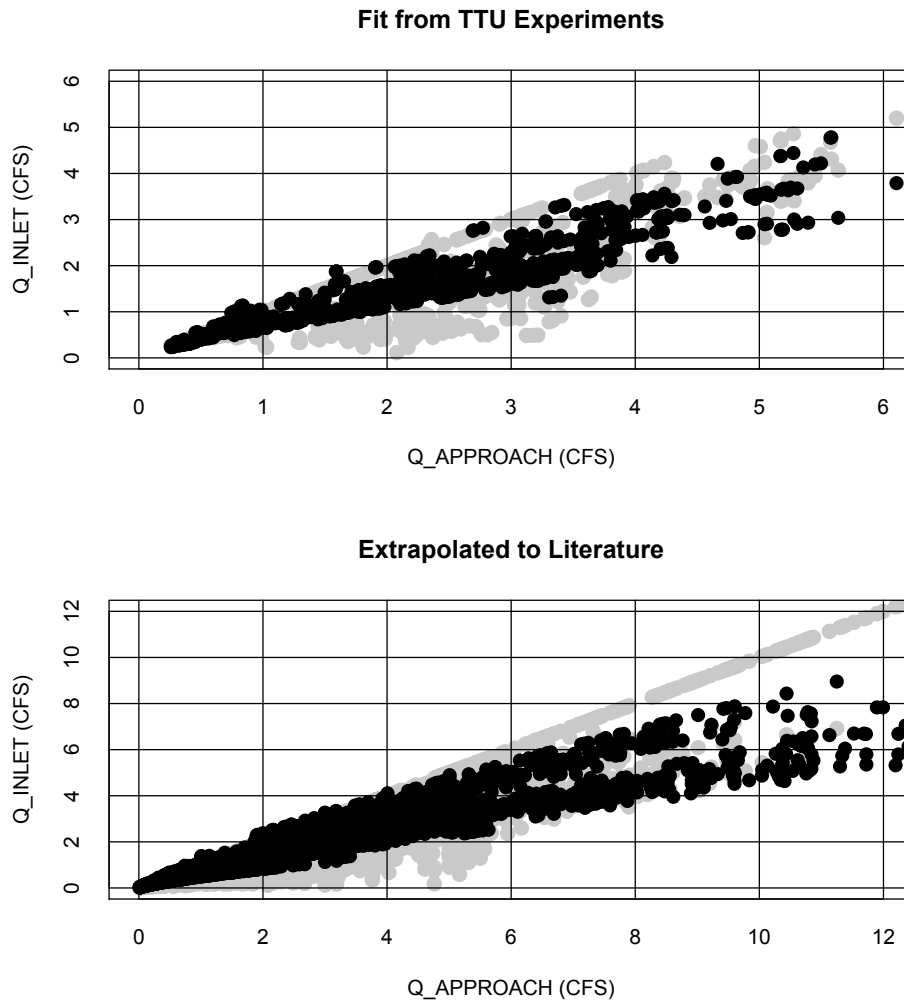

Figure 32: Upper Panel: TTU experimental results (gray markers) and fitted performance model (black markers). Lower Panel: Literature derived results (gray markers) and TTU derived model applied to literature conditions (black markers).

5.2.3 Collective Data Model — Using Literature-Derived and Experimental Results

A final analysis combining the literature-derived and TTU experimental results produced a model not much different than the literature-derived model²⁴.

The relevant **R** commands for using the collective data to construct a power law model of inlet performance are listed below.

Call:

```
lm(formula = log10(Q_INLET[1:4737]) ~ log10(Q_APPROACH[1:4737]) +
    log10(FR[1:4737]) + log10(DEPTH_RATIO[1:4737]) + log10(W.L[1:4737]) +
    log10(LENGTH_RATIO[1:4737]))
```

Residuals:

	Min	1Q	Median	3Q	Max
	-1.03794	-0.08228	0.02940	0.11172	0.43448

Coefficients:

	Estimate	Std. Error	t value	Pr(> t)
(Intercept)	-0.624691	0.011059	-56.487	<2e-16 ***
log10(Q_APPROACH[1:4737])	1.080590	0.005077	212.824	<2e-16 ***
log10(FR[1:4737])	-0.316764	0.008323	-38.057	<2e-16 ***
log10(DEPTH_RATIO[1:4737])	-0.192712	0.023844	-8.082	8e-16 ***
log10(W.L[1:4737])	0.183860	0.012936	14.213	<2e-16 ***
log10(LENGTH_RATIO[1:4737])	0.301354	0.021550	13.984	<2e-16 ***

Signif. codes: 0 '***' 0.001 '**' 0.01 '*' 0.05 '.' 0.1 ' ' 1

Residual standard error: 0.1616 on 4731 degrees of freedom

Multiple R-squared: 0.9184, Adjusted R-squared: 0.9183

F-statistic: 1.065e+04 on 5 and 4731 DF, p-value: < 2.2e-16

The resulting generic inlet performance model is expressed in Equation 9, which is quite similar to the literature derived model, with the same interpretations.

$$Q_i = 10^{-0.624691} (Q_a)^{1.080590} \left(\frac{V_o}{\sqrt{gD}}\right)^{-0.316764} \left(\frac{D}{W}\right)^{-0.192712} \left(\frac{L}{D}\right)^{0.301354} \left(\frac{W}{L}\right)^{0.183860} \quad (9)$$

where Q_i is inlet discharge in cubic feet per second, Q_a is approach discharge in cubic feet per second, $\frac{V_o}{\sqrt{gD}}$ is approach Froude number, D is flow depth in feet, L is inlet length in feet, W is inlet width in feet.

²⁴This result is largely a consequence of nearly 4000 literature-derived values being used in the analysis as compared to the 800 experimentally derived values; with the exception of the inclusion of the aspect ratio that exponents in the power-law model are not changed substantially

Figure 33 is a plot of this generic model and the underlying dataset for which the model is intended to explain. This model provides an alternate tool for inlet performance estimation as outlined in the next section.

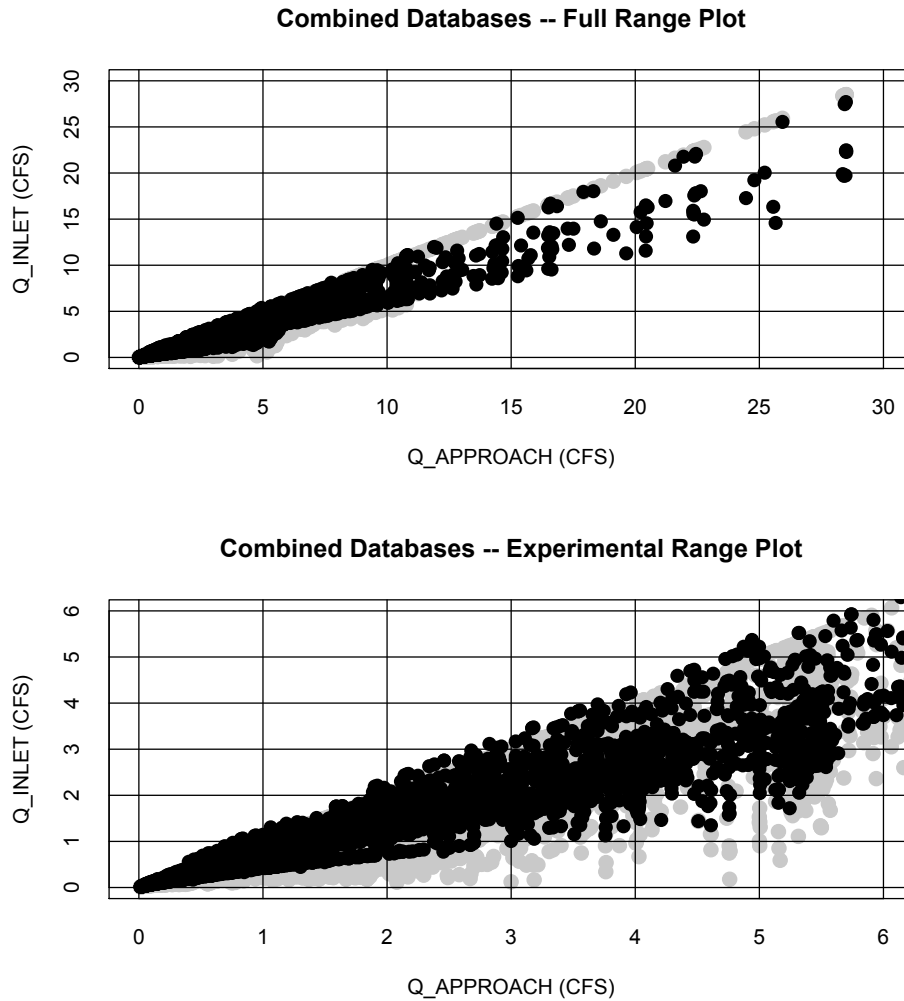

Figure 33: Upper Panel: Combined results (gray markers) and fitted performance model (black markers). Lower Panel: Same plot, but limited to range of TTU experimental conditions

5.3 Analysis of TTU Experiments using SWMM

The Storm Water Management Model (SWMM)(Rossman, 2008) was investigated as a possible performance prediction tool by simulating selected experiments. Its primary attractiveness was the ability to directly incorporate the ditch block (sag conditions) which simply were not easily incorporated into either the HEC-22 procedures or the power-law model.

This subsection describes briefly how a SWMM model of these inlets were constructed, then results for selected experiments are presented. The SWMM approach was investigated very late in the research project, and as such is considered to be part of a suite of design tools, including the HEC-22 and the power-law models.

5.3.1 SWMM Background

The SWMM model is an integrated hydrologic-hydraulic model primarily intended for use in urban runoff modeling. With care, it can be used for quasi-2D surface water modeling, and limited water quality modeling. Quoting from the SWMM user manual:

“The EPA Storm Water Management Model (SWMM) is a dynamic rainfall-runoff simulation model used for single event or long-term (continuous) simulation of runoff quantity and quality from primarily urban areas. The runoff component of SWMM operates on a collection of subcatchment areas that receive precipitation and generate runoff and pollutant loads. The routing portion of SWMM transports this runoff through a system of pipes, channels, storage/treatment devices, pumps, and regulators. SWMM tracks the quantity and quality of runoff generated within each subcatchment, and the flow rate, flow depth, and quality of water in each pipe and channel during a simulation period comprised of multiple time steps.

SWMM was first developed in 1971 and has undergone several major upgrades since then. . . .”

The component of the modeling tool that was used in the Type-H study was the routing portion of the tool, using full dynamic routing. Further quoting from the manual

“ SWMM also contains a flexible set of hydraulic modeling capabilities used to route runoff and external inflows through the drainage system network of pipes, channels, storage/treatment units and diversion structures. These include the ability to:

- handle networks of unlimited size
- use a wide variety of standard closed and open conduit shapes as well as natural channels model special elements such as storage/treatment units, flow dividers, pumps, weirs, and orifices
- apply external flows and water quality inputs from surface runoff, groundwater interflow, rainfall-dependent infiltration/inflow, dry weather sanitary flow, and

user-defined inflows

- utilize either kinematic wave or full dynamic wave flow routing methods
- model various flow regimes, such as backwater, surcharging, reverse flow, and surface ponding
- apply user-defined dynamic control rules to simulate the operation of pumps, orifice openings, and weir crest levels.

... ”

SWMM uses Manning’s equation to express the relationship between flow rate, cross-sectional area, hydraulic radius, and slope in all conduits. The slope is interpreted as either the conduit slope or the friction slope (i.e., head loss per unit length), depending on the flow routing method used. In this study, dynamic routing was used, hence the slope in the flow equations is the friction slope.

Further quoting from the SWMM user manual

“Dynamic Wave routing solves the complete one-dimensional Saint Venant flow equations and therefore produces the most theoretically accurate results. These equations consist of the continuity and momentum equations for conduits and a volume continuity equation at nodes. With this form of routing it is possible to represent pressurized flow when a closed conduit becomes full, such that flows can exceed the full normal flow value. Flooding occurs when the water depth at a node exceeds the maximum available depth, and the excess flow is either lost from the system or can pond atop the node and re-enter the drainage system.

Dynamic wave routing can account for channel storage, backwater, entrance/exit losses, flow reversal, and pressurized flow. Because it couples together the solution for both water levels at nodes and flow in conduits it can be applied to any general network layout, even those containing multiple downstream diversions and loops. *It is the method of choice for systems subjected to significant backwater effects due to downstream flow restrictions and with flow regulation via weirs and orifices.* This generality comes at a price of having to use much smaller time steps, on the order of a minute or less (SWMM will automatically reduce the user-defined maximum time step as needed to maintain numerical stability).

Each of these routing methods employs the Manning equation to relate flow rate to flow depth and bed (or friction) slope. ... ”

SWMM was used in this study as a reverse-engineering tool; that is rather than specify inlet behavior by some equation (weir or orifice) and force routing to occur as desired, a hydraulic structure was created that closely mimicked the physical model, and the program allowed to find an equilibrium solution (by running the dynamic model to large elapsed time). This solution was then examined and certain loss elements added to the computer representation to match observations.

5.3.2 SWMM representation of TTU laboratory apparatus

Figure 34 is the schematic diagram (in the SWMM tool) of the Texas Tech experimental apparatus. The inlet was modeled in SWMM as a storage node. The approach and overflow sections were trapezoidal channels with 2-ft bottom width and 6:1 side slopes as existed in the laboratory conditions. The outlet path in the diagram was a 1-ft diameter, circular conduit, with the exception of the “curved” conduit in the diagram. This curved conduit is a circular conduit with a diameter set equal to the flow restrictor diameters used in the actual model.

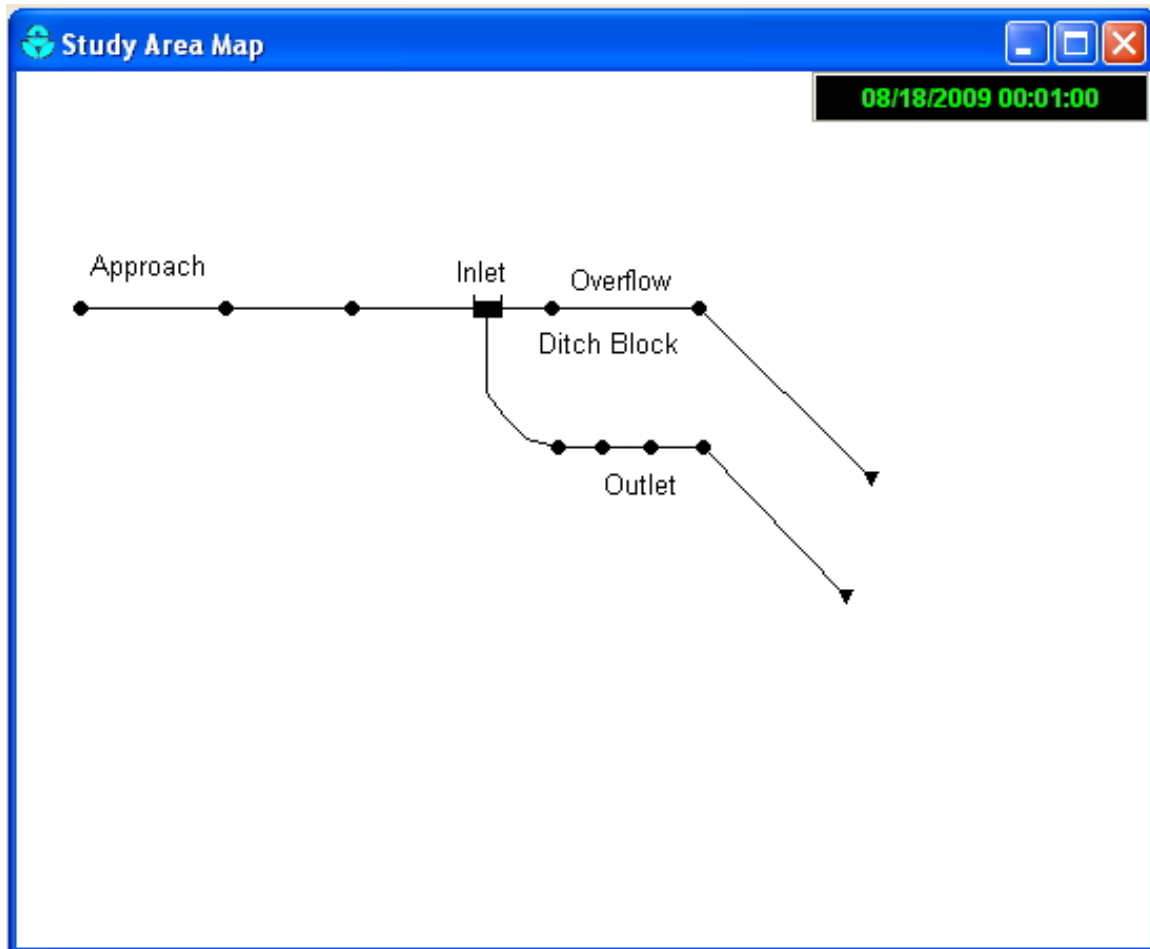

Figure 34: SWMM representation of TTU laboratory apparatus

The nodes (small circles in the schematic) were used to set elevations to reconstruct the longitudinal slope used in the experiments. The two “outlet” nodes (the small triangles) represented free-overfall boundary conditions. The justification for these boundary conditions was as follows

1. The open channel section (overflow) was indeed an open channel that dropped into the return flow tank, and thus was the epitome of a free overfall outlet.

2. The outlet pipe in the actual model dropped into the return tank through a T-fitting. The researchers anticipated that this condition would be something other than free overfall except in over 200 experiments the vertical section water elevation never appeared to rise above the invert elevation of the horizontal portion of the pipe. The flow depth in the pipe never exceeded 60 percent of the pipe diameter, with high velocity conditions reflective of unrestricted outfall. There was no observed evidence of backwater in the experiments. Hence, this pipe was also justifiably modeled as a free-overfall condition.

The “ditch-block” node was treated as an ordinary node, but its elevation was changed to reflect the presence or absence of a ditch block. Figure 35 is a profile plot (in the SWMM tool) that illustrates the geometric relationship of the channel bottom, the inlet node, and the ditch block. Figure 36 is a profile plot (in the SWMM tool) that illustrates the outlet works portion of the model. From the approach to the inlet the profile is identical to the overflow profile. Past the inlet node, only the outlet works are displayed.

To vary the simulated topographic slope, the elevations at the nodes are changed to reflect different slopes along the channel.

Each link in the open-channel portion of the model was 8-ft long, and this distance choice is somewhat arbitrary. Shorter links might make sense, but longer links do not. The link from the inlet node to the ditch block was 2-ft. In the outlet works portion, all the links are 2-ft long, except the last link which is 8-ft long, again, a somewhat arbitrary choice. The researchers did not think that fewer links would make much sense as part of the task was to capture the observed depth taper in the experiments and for this information to participate in the hydraulics computations.

The roughness coefficient used was 0.011 in all links. This value represents the lower end of smooth concrete (Chin, 2006). In contrast to specifying inlet behavior by forcing SWMM to follow a user-prescribed weir or orifice equation²⁵, the inlet node was modeled as a special component in this SWMM model. This node has the following special conditions:

1. The inlet was treated as a storage node. The storage area was set to be equal to 60 percent of the inlet area. Thus a 1X1 inlet has a plan view area of 1 ft² so the model inlet area is 0.6 ft², 2X2 had a plan view of 4 ft², so the model inlet area is 2.4 ft², and so on. The lid condition area used is the product of lid perimeter and opening height. Grating was ignored.
2. The functional exponent on the depth-area relationship in the SWMM model storage node was set to 1.0. Thus, storage volume was the product of the node area and the current depth above the invert.
3. The inlet invert elevation was the reference elevation. It was taken as 1.5 ft below the bottom of the channel.
4. The channel links were incorporated into the inlet using offset elevations in the SWMM model. In this research, the offsets were 1.5 feet.

²⁵A HEC-22 inlet capacity equation could conceivably be programmed into SWMM. Such an act defeats the purpose of the analysis, that is to learn if using simple hydraulic elements observed behavior can be replicated.

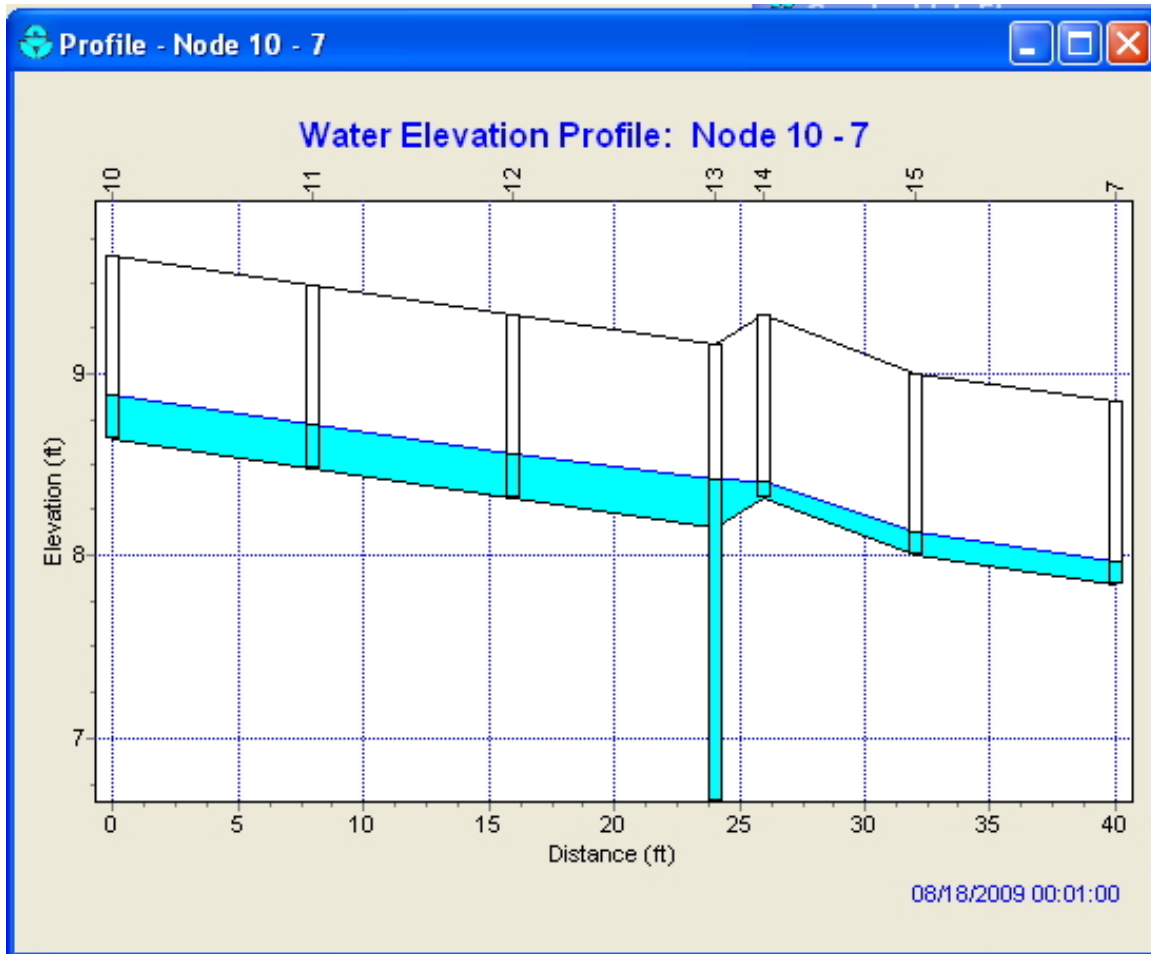

Figure 35: Elevation profile from approach to the inlet, then over the ditch block to the return sump. This figure is representative, the water surface shown is the result of some particular simulation and is not generic.

5. The link that leaves the inlet node and connects to the outlet works was set to have an added inlet head loss coefficient of $0.6 + 2D$, where D is the outlet restrictor diameter in feet. These values were selected ad-hoc from a few trial models then used throughout the remainder of the study.

To reiterate, the inlet node is a storage node with special geometric properties as just described. Other than this feature (storage of water and inlet/outlet offsets), the node is otherwise a generic SWMM storage node. The node does not contain any special operational rules that force weir-type, orifice-type, or any other type of prescribed flow.

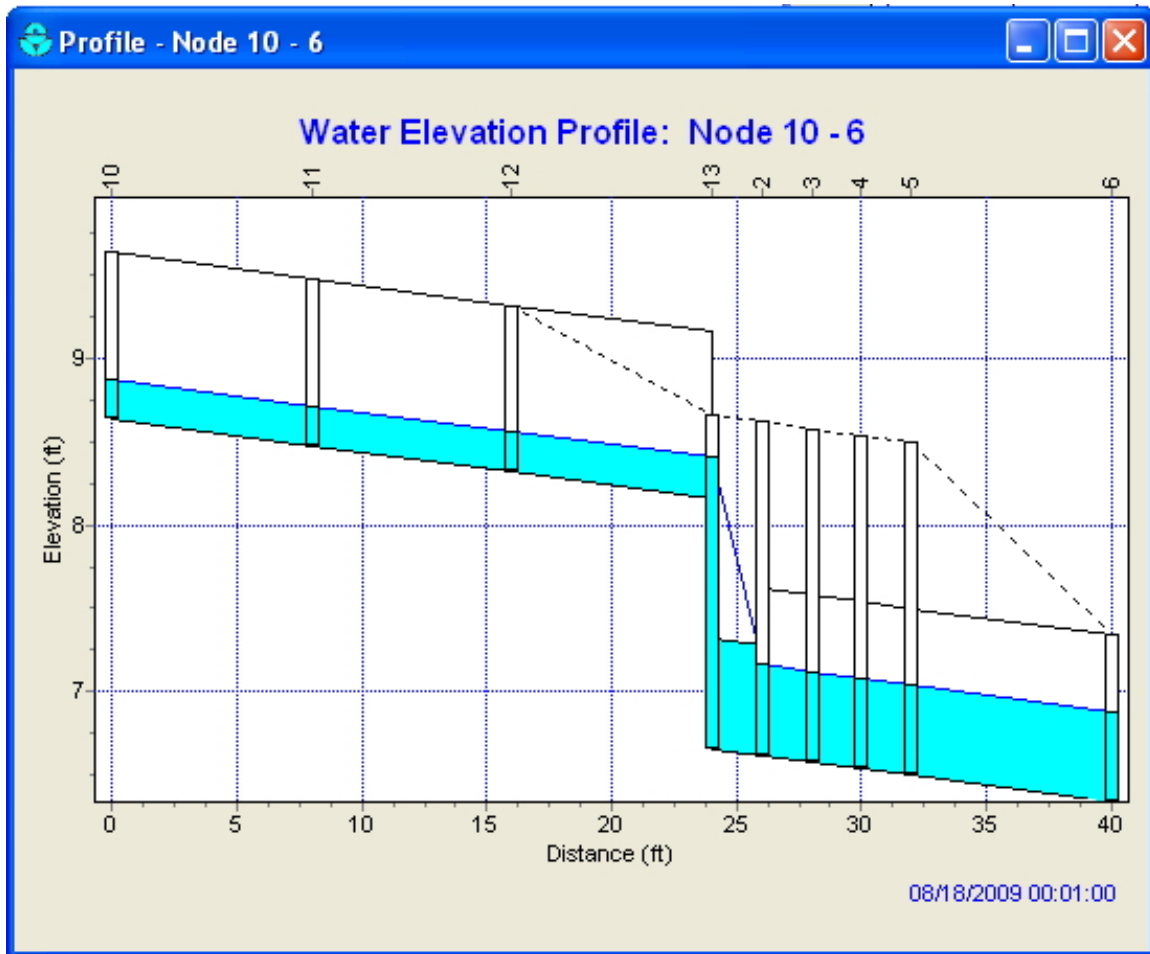

Figure 36: Elevation profile from approach to the inlet, then through the outlet works. This figure is representative, the water surface shown is the result of some particular simulation and is not generic.

5.3.3 Representative SWMM simulations

Sixty simulations of selected experiments were conducted using SWMM and the modeling principles described. The SWMM model was not systematically calibrated for each run, however the following steps were employed to determine certain variable values:

1. The storage node area was adjusted by trial-and-error for a few trial models, then used throughout the remainder of the study. An area of 60% of the actual physical area produced results that were faithful to the observations in the few trial runs.
2. The outlet link (restrictor plates) were assigned a head loss coefficient equal to twice their diameter in feet plus 0.6. This empirical approach produced minor loss coefficients in this

link ranging from 1.2 to nearly 2.0.

In general, with only this very cursory calibration approach the SWMM results were not only promising, but reasonably faithful to the experimental observations.

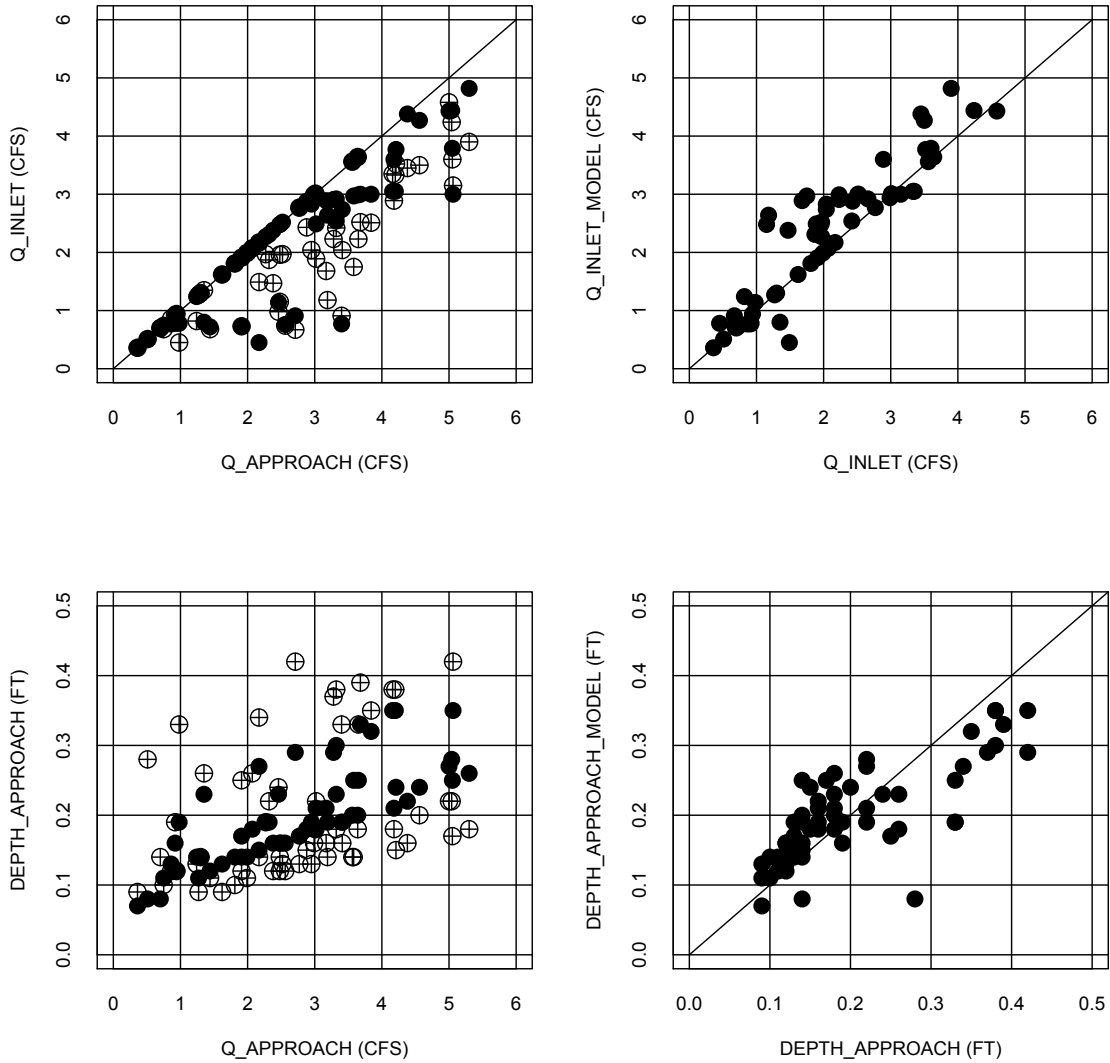

Figure 37: Comparative SWMM Simulation Results. Upper left panel is observed (cross-hair markers) and simulated (solid markers) inlet capture for a subset of the experiments. Upper right panel is observed and simulated capture discharge, with an equal-value line for comparison. Lower left panel is observed (cross-hair markers) and simulated (solid markers) approach depth. Lower right panel is observed and simulated approach depths, with an equal-value line for comparison.

Figure 37 is a set of plots that compare these selected simulations. These plots indicate that SWMM can indeed model the physical model with some fidelity²⁶ with a comparatively simple description of the inlet node. The SWMM model is biased and will tend to predict better performance than was actually observed, however, unlike the power-law model or the HEC-22 methodology, SWMM did seem to predict when full inlet capture occurs — a result that the power-law model simply cannot capture, and HEC-22 requires some guesswork.

Table 3 lists the selected simulations that were used to generate the plots in Figure 37.

Table 3: SWMM Comparative Simulations for Type-H Inlet Hydraulic Characteristics Study.

[S_0 is the longitudinal slope of the physical model, INLET is the inlet configuration, OUTLET is the restrictor plate diameter, SAG is a binary indicator of the presence of a ditch block, Q_A is the observed approach discharge, Q_I is the observed capture discharge, Q_I -Model is the simulated capture discharge, D_A is the observed approach depth, D_A -Model is the simulated approach depth.]

S_0	INLET	OUTLET	SAG	Q_A	Q_I	Q_I -Model	D_A	D_A -Model
0.005	1X1	8	YES	5.06	3.15	3	0.42	0.35
0.005	1X1	8	YES	3.32	2.66	2.92	0.38	0.3
0.005	1X1	8	YES	1.91	1.91	1.91	0.25	0.17
0.005	1X1	8	YES	0.94	0.94	0.94	0.12	0.12
0.005	1X1	8	YES	0.36	0.36	0.36	0.09	0.07
0.005	2X2	8	YES	1.3	1.3	1.3	0.14	0.14
0.005	2X2	8	YES	2.07	2.07	2.07	0.26	0.18
0.005	2X2	8	YES	3.28	2.23	2.91	0.37	0.29
0.005	2X2	8	YES	3.68	2.52	3	0.39	0.33
0.005	2X2	8	NO	2.32	1.87	2.31	0.22	0.19
0.005	2X2	8	NO	3.32	2.42	2.54	0.18	0.23
0.005	1X1-T	8	YES	0.75	0.68	0.75	0.1	0.11
0.005	1X1-T	8	YES	1.24	0.82	1.24	0.13	0.14
0.005	1X1-T	8	YES	3.65	2.23	2.99	0.33	0.25
0.005	1X1-T	8	YES	3.84	2.51	3	0.35	0.32
0.005	1X1-T	8	YES	4.16	3.35	3.05	0.38	0.35
0.005	1X1-T	8	YES	4.2	3.33	3.05	0.38	0.35
0.005	1X1-T	8	NO	3.02	1.89	2.49	0.22	0.21
0.005	1X1-T	8	NO	2.27	1.97	2.27	0.19	0.19
0.005	1X1-T	4	YES	2.17	1.49	0.45	0.34	0.27
0.005	1X1-T	4	YES	0.86	0.86	0.77	0.12	0.13
0.005	1X1-T	4	YES	1.35	1.35	0.8	0.26	0.23
0.005	1X1-T	4	YES	0.51	0.51	0.51	0.28	0.08
0.005	1X1-T	4	YES	0.98	0.45	0.78	0.33	0.19

Continued on next page

²⁶This result is not surprising, the relatively minimal calibration manipulation was however quite reassuring.

Table 3: SWMM Comparative Simulations — Continued

S_0	INLET	OUTLET	SAG	Q_A	Q_I	Q_I -Model	D_A	D_A -Model
0.005	1X1-T	4	YES	2.71	0.67	0.91	0.42	0.29
0.01	2X2	12	YES	5.04	4.24	4.44	0.22	0.28
0.01	2X2	12	YES	5	4.58	4.43	0.22	0.27
0.01	2X2	12	YES	3.64	3.64	3.64	0.18	0.2
0.01	2X2	12	YES	2.99	2.99	2.94	0.16	0.18
0.01	2X2	12	NO	4.18	2.89	3.6	0.18	0.21
0.01	2X2	12	NO	2.88	2.43	2.88	0.15	0.18
0.01	2X2	8	NO	2.48	1.96	2.48	0.14	0.16
0.01	2X2	8	NO	3.41	2.04	2.74	0.16	0.19
0.01	2X2	4	NO	1.91	0.73	0.73	0.12	0.14
0.01	2X2	4	NO	1.44	0.68	0.72	0.11	0.12
0.01	LID	12	YES	4.56	3.5	4.27	0.2	0.24
0.01	LID	12	YES	3.01	3.01	3.01	0.18	0.18
0.01	LID	12	YES	2.17	2.17	2.17	0.14	0.15
0.01	LID	4	YES	2.46	0.98	1.14	0.24	0.23
0.01	LID	4	YES	0.92	0.92	0.78	0.19	0.16
0.01	LID	4	YES	0.7	0.7	0.7	0.14	0.08
0.02	1X1	8	YES	3.17	1.68	2.89	0.16	0.21
0.02	1X1	8	YES	2.52	1.97	2.52	0.13	0.16
0.02	1X1	8	YES	1.62	1.62	1.62	0.09	0.13
0.02	1X1	8	YES	1.27	1.27	1.27	0.09	0.11
0.02	1X1	8	NO	3.19	1.18	2.64	0.14	0.19
0.02	1X1	8	NO	2.48	1.15	2.48	0.12	0.16
0.02	1X1	4	NO	3.4	0.91	0.77	0.33	0.19
0.02	1X1	4	NO	2.56	0.74	0.76	0.12	0.16
0.02	2X2	8	YES	2.95	2.04	2.83	0.13	0.19
0.02	2X2	8	YES	1.99	1.99	1.99	0.11	0.14
0.02	2X2	12	YES	5.3	3.9	4.82	0.18	0.26
0.02	2X2	12	YES	4.38	3.45	4.38	0.16	0.22
0.02	2X2	12	YES	3.56	3.56	3.56	0.14	0.2
0.02	1X1-T	12	YES	3.58	1.75	2.97	0.14	0.25
0.02	1X1-T	12	NO	2.38	1.47	2.38	0.12	0.16
0.02	LID	12	YES	5.05	3.6	3.79	0.17	0.25
0.02	LID	12	YES	4.21	3.52	3.77	0.15	0.24
0.02	LID	12	YES	2.77	2.77	2.77	0.13	0.17
0.02	LID	12	YES	1.81	1.81	1.81	0.1	0.14

6 Type-H Inlet Performance Prediction

The pervious chapter analyzed literature-derived data and experimental data to develop design guidance in regards to Type-H and similar drop inlets. The analysis determined that the HEC-22 weir-flow equations are reasonably explanatory of the experimental results collected in the TTU experiments. A power-law model was constructed to investigate important flow parameters that appear to govern inlet behavior. The U.S. EPA SWMM (Rossman, 2008) computer program was also used to explain inlet performance. This chapter illustrates how an analyst can use these various tools to predict inlet performance by means of examples.

These examples are constructed to predict performance for actual physical model conditions so that the predicted performance can be compared to actual experiments. The examples are organized first for Non-Sag conditions, then for Sag conditions. Within this classification, examples to predict performance using HEC-22 methods, the power-law model, and a SWMM based approach are presented.

6.1 Type-H Inlet Performance Prediction, Non-Sag Conditions

Non-sag conditions represent the case where an inlet would be placed at grade or in a drainage ditch, but the inlet is not located in a substantial sump. There is no ditch-block or other physical structure to increase flow depth above the inlet.

Performance prediction is possible using HEC-22 and the weir equation within that document. Additionally, the median inlet calculations presented in the manual also provide some estimation capability assuming the Type-H inlet behaves as a P-30 grate inlet. Performance prediction is also possible using the power-law model developed as part of this research. Lastly, performance prediction using the SWMM program appears to be possible and may be a promising approach to inlet performance evaluation. This subsection presents illustrative examples of performance prediction using each technology.

6.1.1 Performance Prediction using HEC-22 in Non-Sag Conditions

This example presents the use of HEC-22 in non-sag conditions. The example serves to illustrate that HEC-22 procedures are predictive of the laboratory results.

The conditions of experiment #267 are used as the observational comparison values. The example follows the procedures presented on page 4-87 of the HEC-22 document (Brown et al., 2001). The Type-H inlets studied at TTU appear to be reasonably approximated by the P30 grate in HEC-22, however the HEC-22 tool regarding inlets varies considerably depending on the grate type. This variability is a challenge, furthermore the HEC-22 tools were developed at different times and in different laboratories. There may be subtle, undocumented experimental differences that explain the differences in grate-type and splash over velocity (HEC-22 Chart 5B).

The physical conditions are as follows.

1. $Q_A = 5.00$ cfs. ; The approach discharge.
2. $S_0 = 0.02$; Longitudinal slope.
3. $S_X = 0.16$; Transverse slope. In HEC-22 parlance this condition is a 1:6 side slope.
4. $B = 2$ feet. Bottom width of the trapezoidal channel.
5. $Z = 6$; Side slope “run” (i.e. $S_X = \frac{1}{Z}$)
6. $W_I = 2$ feet. Inlet width.
7. $L_I = 2$ feet. Inlet length (along the long axis of the channel).
8. $n = 0.011$. Roughness coefficient (Manning’s n). This value is reflective of the experimental conditions and represents the lower range of values for float-finished concrete as reported in Chin (2006).

The HEC-22 analysis follows assuming the approach flow is $Q_A = 5.0$ cfs.

1. Compute the ratio of frontal to total flow.
 - (a) Compute $Q_A \times n = (5.00)(0.011) = 0.055$.
 - (b) Use chart 14B (on next or facing page)²⁷ to determine $\frac{d}{B}$ where d is the approach flow depth. In this instance $\frac{d}{B} = 0.105$.
 - (c) Determine the approach flow depth from $d = B \times (\frac{d}{B})$.
In this instance $d = (2)(0.105) = 0.21$ feet.
 - (d) Use HEC 22, equation 4-38 to compute a frontal flow ratio,
$$E_0 = \frac{W_I}{B+d \times z} = \frac{2}{2+0.21(6)} = 0.6135$$

²⁷The chart is extrapolated an extra log cycle on the Qn axis to accommodate the shallow flow in the laboratory experiments.

CHART 14B

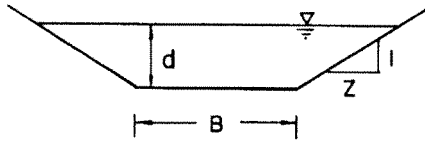

NOTE: Project horizontally from Z=0 scale to obtain values for Z=1 to 6

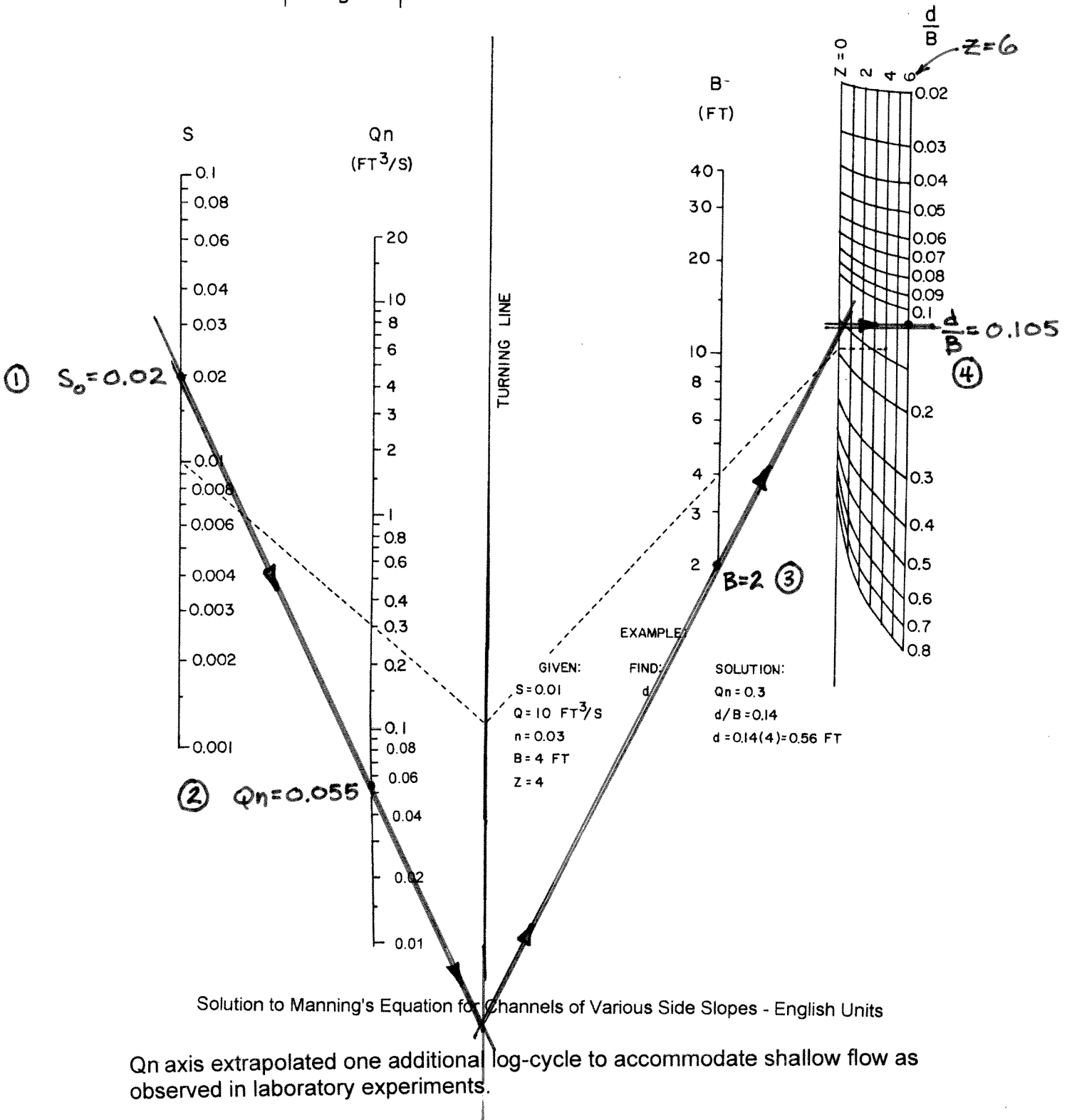

Solution to Manning's Equation for Channels of Various Side Slopes - English Units

Q_n axis extrapolated one additional log-cycle to accommodate shallow flow as observed in laboratory experiments.

2. Compute frontal flow efficiency.

(a) Compute approach flow cross section area, $A = d(B + d \times Z)$.

In this instance, $A = 0.21(2 + 0.21(6)) = 0.6846 \text{ ft}^2$

(b) Compute approach velocity, $V = \frac{Q}{A} = \frac{5.0}{0.6846} = 7.3 \text{ ft/sec}$.

(c) Use Chart 5B (on next or facing page) to recover the frontal flow efficiency for this value of velocity. For this example the P-30 (P 1-1/8) grate was assumed as representative. In this example, the frontal flow efficiency is $R_f = 0.95$.

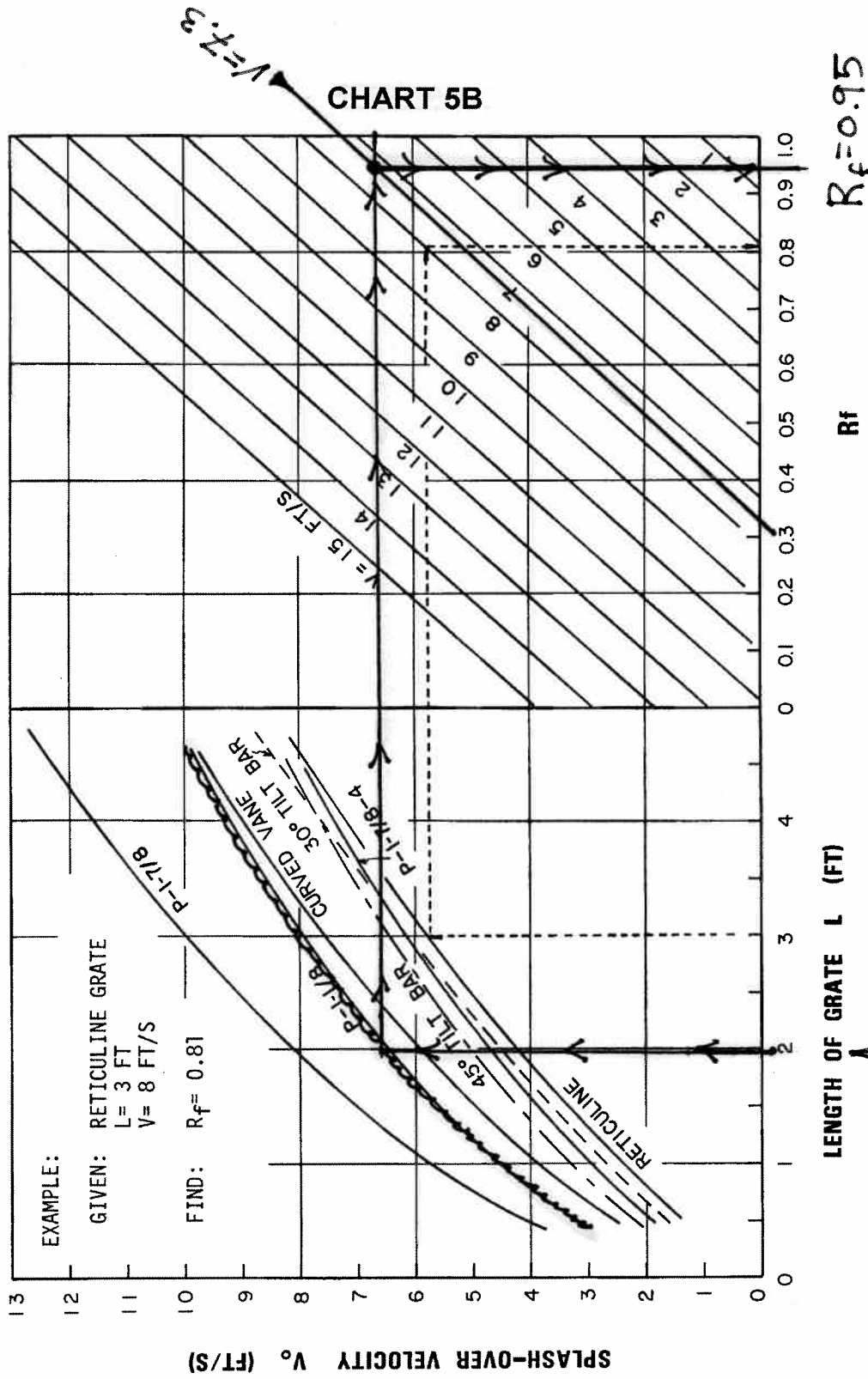

3. Compute side flow efficiency. Use Chart 6B (on next or facing page) to determine side flow efficiency factor, R_s .
 - (a) The chart is entered with the side slope value in the lower left-hand part of the chart (S_X).
 - (b) The analyst proceeds horizontal until the intersection of S_X with the inlet length L_I .
 - (c) From the intersection, the analyst then draws a line segment vertically upward to intersect with the approach velocity for the inlet.
 - (d) From this intersection the analyst reads the associated side flow efficiency.

In this example, the result is a side flow efficiency of about $R_s = 0.13$.

4. Compute total capture efficiency, $E = E_0R_f + (1 - E_0)R_s$. In this example, $E = 0.6135(0.95) + (1 - 0.6135)(0.13) = 0.63307$.
5. Compute interception and bypass flow(s); $Q_I = 0.63307(5.0) = 3.16$ cfs., and $Q_O = Q_A - Q_I = 5.00 - 3.16 = 1.84$ cfs.

For this particular experiment the observed capture and overflow discharges were (with rounding) $Q_I = 3.52$ cfs and $Q_O = 1.48$ cfs. The observed approach depth was 0.18 feet (suggestive of even smoother channel material than used in the example calculations). The HEC-22 approach in this example is reasonably close to observations (within 20 percent relative error).

CHART 6B

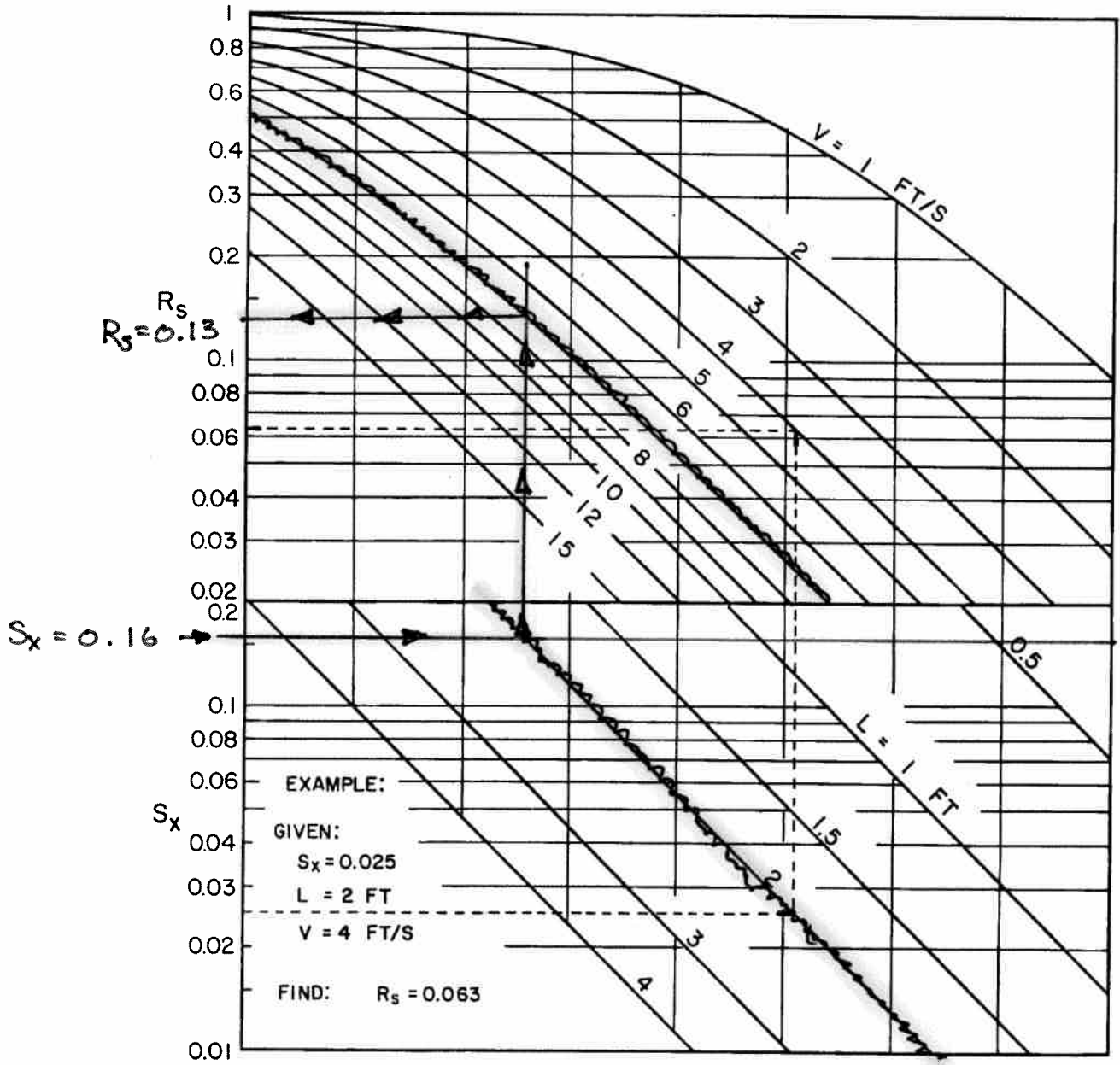

Grate Inlet Side Flow Intercept Efficiency

$S_x = 0.16$

6.1.2 Performance Prediction using Power-Law Model in Non-Sag Conditions

The power-law model provides an alternate method to predict performance, and is suggested as an additional check on other estimates. Using the same physical conditions as in the previous example, the use of the power-law model is illustrated.

1. Specify approach discharge, Q_a . In this example $Q_a = 5.0$ cfs.
2. Determine the approach flow depth, D . If the Type-H inlet is located in a trapezoidal channel, HEC-22 Equation (4-32),²⁸ or Chart 14 can be used to determine the approach flow depth. In all geometries, the longitudinal slope, S_0 , is required to enter either the chart or use the equation.

In this example, the previous result from Chart 14 is used to compute $D = 0.21$ feet is used.

3. Determine approach flow cross-sectional area, A . In this example, $A = 0.6846$ ft²
4. Determine approach flow mean section velocity, $V = \frac{Q_a}{A}$. In this example, $V = 7.3$ ft /sec
5. Determine the approach Froude number, $Fr = \frac{V}{\sqrt{gD}}$. In this example, $Fr = \frac{7.3}{\sqrt{32.2(0.21)}} = 2.80$
6. Determine the depth to inlet width ratio, $\frac{D}{W}$, where W is the width of the inlet²⁹. In this example (to compare with experimental results), $\frac{D}{W} = \frac{0.21}{2.0} = 0.105$.
7. Determine the inlet length to depth ratio, $\frac{L}{D}$, where L is the length of the inlet. In this example (to compare with experimental results), $\frac{L}{D} = \frac{2}{0.21} = 9.52$.
8. Determine the inlet aspect ratio, $\frac{W}{L}$. Typically the aspect ratio will be unity (square inlets). In this example the aspect ratio is unity.
9. Compute the inlet capture discharge from Equation 9 (repeated below)

$$Q_i = 10^{-0.624691} \times Q_a^{1.08059} \times \left(\frac{V_o}{\sqrt{gD}}\right)^{-0.316764} \times \left(\frac{D}{W}\right)^{-0.192712} \times \left(\frac{L}{D}\right)^{0.301354} \times \left(\frac{W}{L}\right)^{0.18386} \quad (10)$$

In this example the result is obtained from Equation 11,

$$Q_i = 10^{-0.624691} \times (5)^{1.08059} \times (2.80)^{-0.316764} \times (0.105)^{-0.192712} \times (9.52)^{0.301354} \times (1)^{0.18386} \quad (11)$$

which evaluates to $Q_i = 2.967$ cfs. Paying attention to reasonable significant digits, $Q_i = 2.97$ would be a suitable estimate.

10. Overflow, if any is $Q_o = Q_a - Q_i$. Use the overflow value to analyze for next inlet downstream. In this case, $Q_o = 2.03$ cfs. For this particular experiment the observed capture and overflow discharges were (with rounding) $Q_I = 3.52$ cfs and $Q_O = 1.48$ cfs. The observed approach depth was 0.18 feet. Compared to the experimental results, the power law model is reasonably close (within 35 percent relative error), and or comparable complexity to apply.

²⁸The equation in the current on-line version of the document has a typographic error

²⁹For Type-H the width will be between 3 and 5 feet

6.1.3 Performance Prediction using SWMM in Non-Sag Conditions

SWMM provides another estimation tool. Using the SWMM configuration described below, the inlet performance is estimated.

1. Build an appropriate channel, inlet, and overflow section for the estimation. In the present case the channel is trapezoidal with dimensions described above.

Figure 38 is a screen capture of the program depicting data entry for the approach channel.

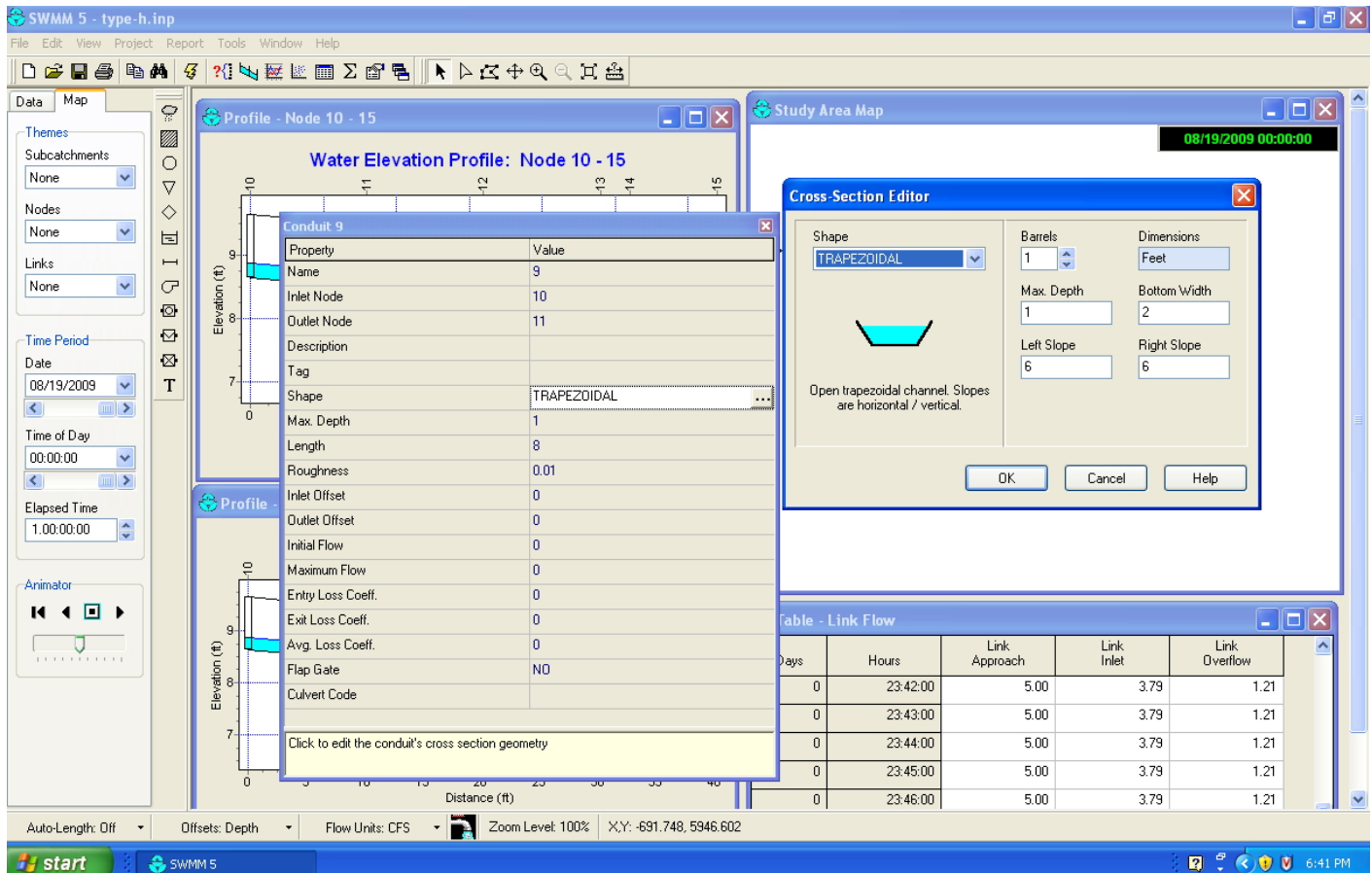

Figure 38: SWMM representation of approach channel.

2. Build the inlet as a storage node with node area equal to 0.6(inlet area). In this example the inlet area is $2 \times 2 = 4$ square feet. Six-tenths of that value is 2.4. This value is supplied as the storage node area. The depth-area exponent is set to 1.0. The invert elevation of the storage node is the bottom of the vault box.

The researchers suggest that a datum be selected so that all invert elevations in the model are greater than zero. The program can accept negative elevations, but the researchers have

found this approach to be quite confusing and in their opinion it is far easier for the analyst to use a datum that produces positive elevations in the model.

Figure 39 is a screen capture of the program depicting data entry for the storage node (the inlet node in this protocol).

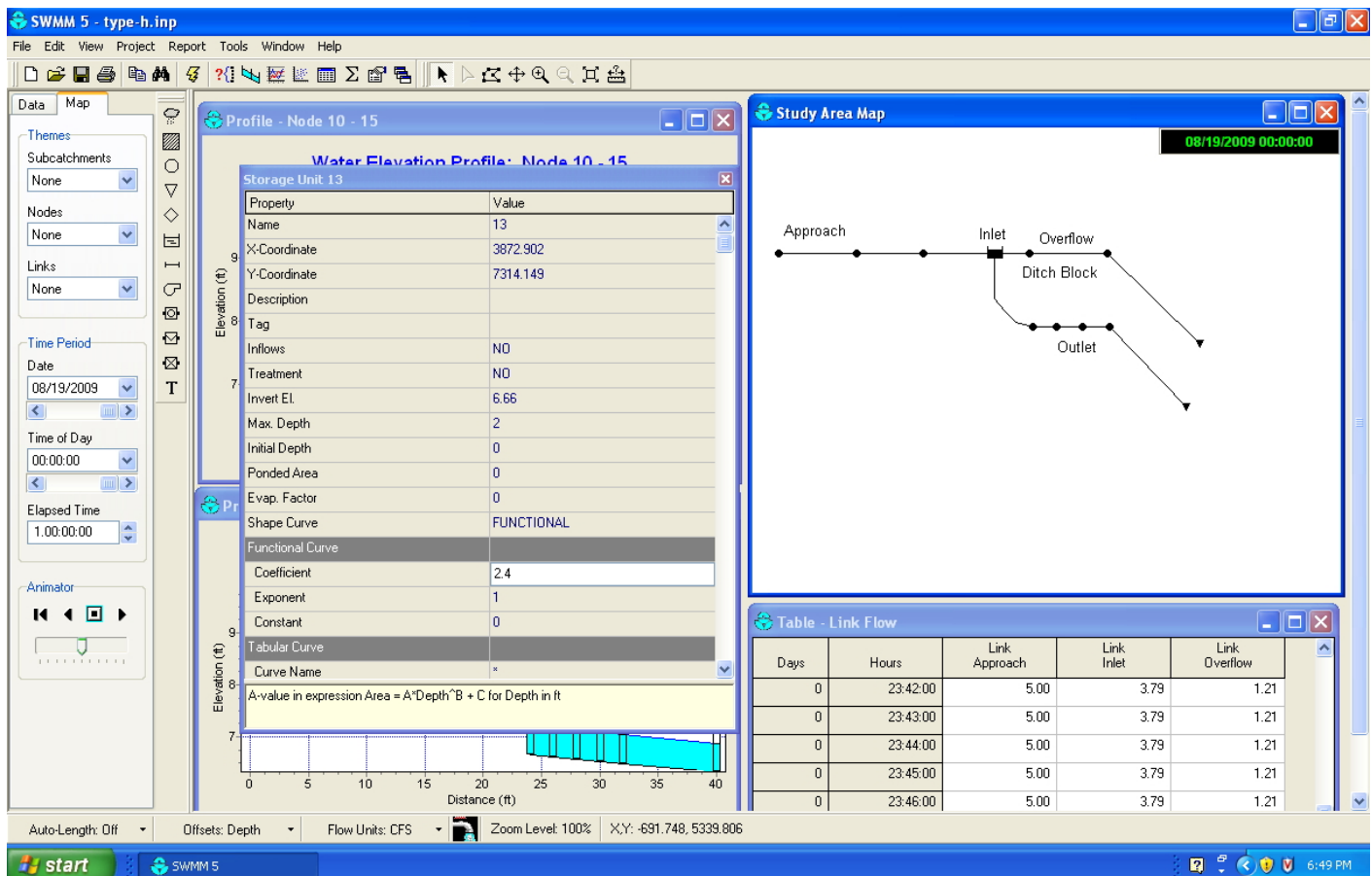

Figure 39: SWMM representation of the inlet as a storage node.

3. Build the outlet works (pipe system that drains the vault box under the drop inlet) appropriate to the actual physical conditions. An ad-hoc entrance loss coefficient of 0.6 was used in this research with an added average loss coefficient of 2.0.

Figure 39 is a screen capture of the program depicting data entry for the outlet link. Of importance are the added head loss coefficients in the entry sheet.

4. Supply the approach discharge at the upstream supply node.

Figure 39 is a screen capture of the program depicting data entry for the upstream supply node. Other ways to supply this discharge are available in SWMM, the analyst can choose the most appropriate method as per their experience.

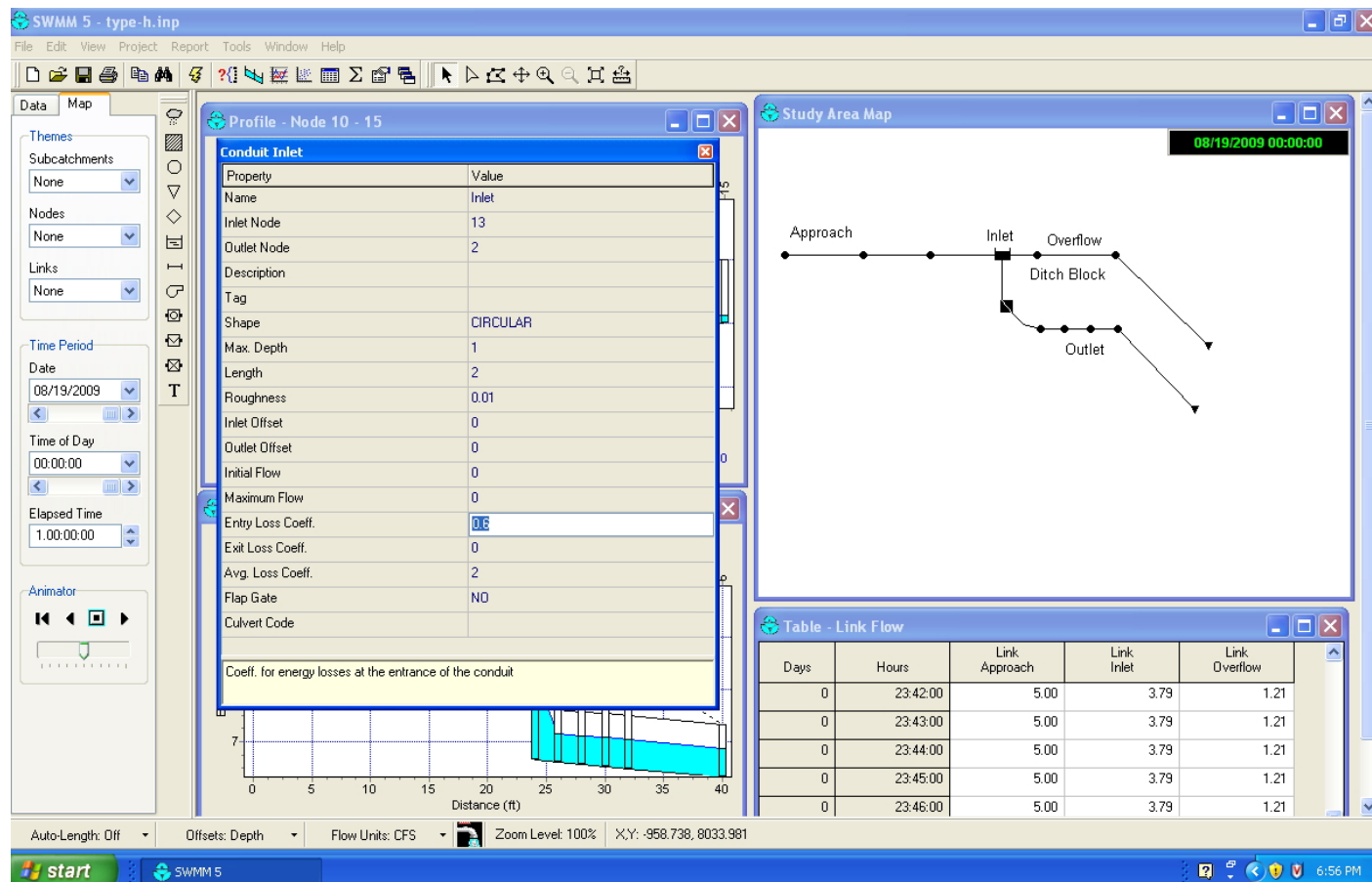

Figure 40: SWMM representation of the outlet link from the vault box (storage node) to the subsurface drainage system.

- Run the simulation and capture the output. Figure 42 is a screen capture of the program after a simulation run. The researchers, by force of habit, used the dynamic (non-steady flow) modeling approach and specify relatively long simulation times. The concept is to let the numerical code approach an equilibrium response and then report this response as the quasi-steady anticipated performance. The steady-flow algorithms in SWMM are NOT used.

In this example, using the same geometry as the prior two methods, the resulting inlet capture discharge is $Q_i = 3.79$ cfs. and overflow discharge is $Q_o = 1.21$ cfs. As with the other two approaches the results are reasonably close to experimental results (within 20 percent relative error). As with HEC-22 and the power-law model, the SWMM model is comparable in difficulty.³⁰

³⁰SWMM is not a trivial program, the comparative simplicity comes at the cost of having to learn how to operate SWMM. Once an analyst has skill with the tool, SWMM is as straightforward as either the HEC-22 or power-law model.

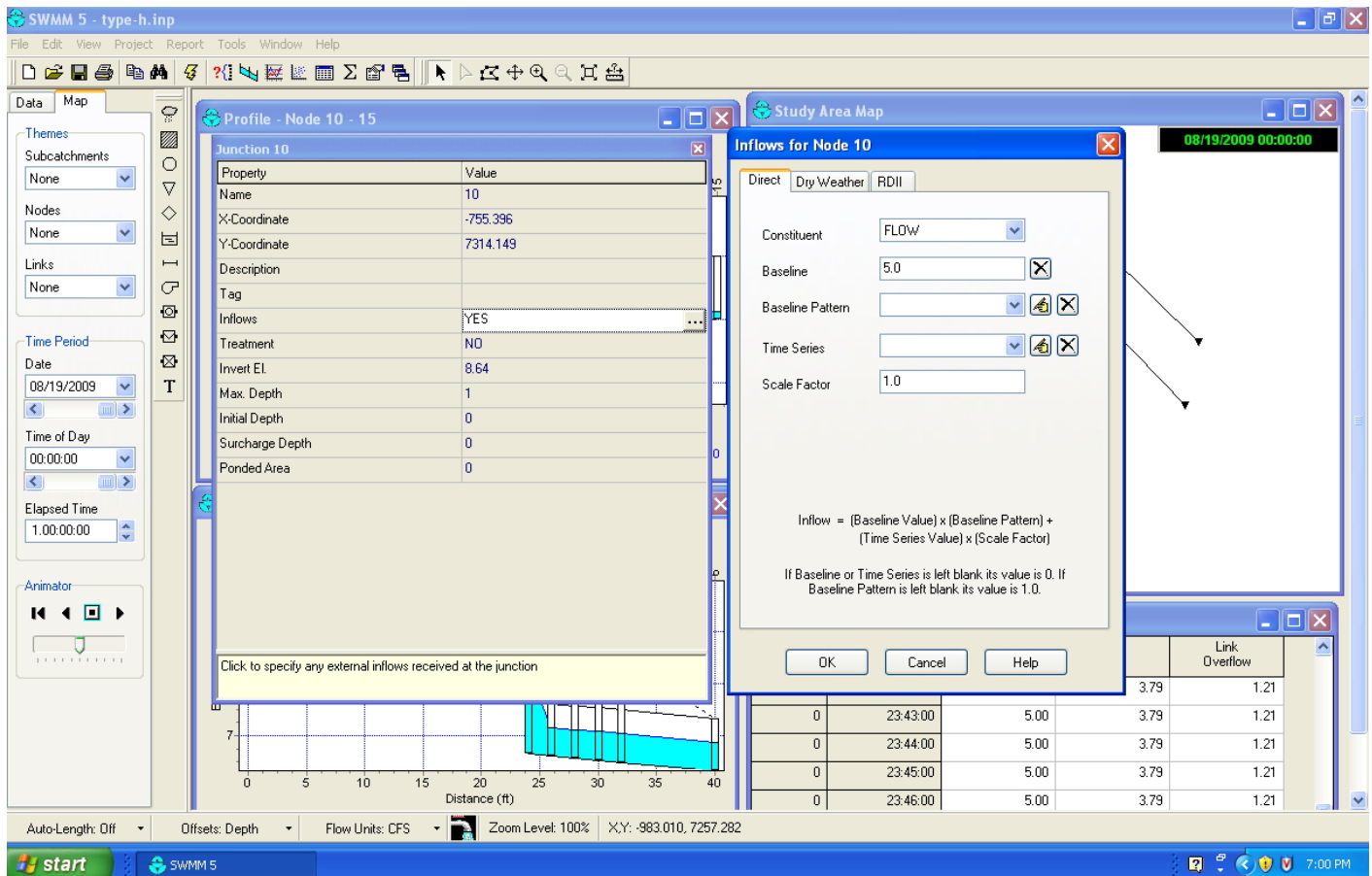

Figure 41: SWMM representation of supply flow data entry. The data dialog box corresponds to the left-most node in the system map, and only this node is supplied with external flows.

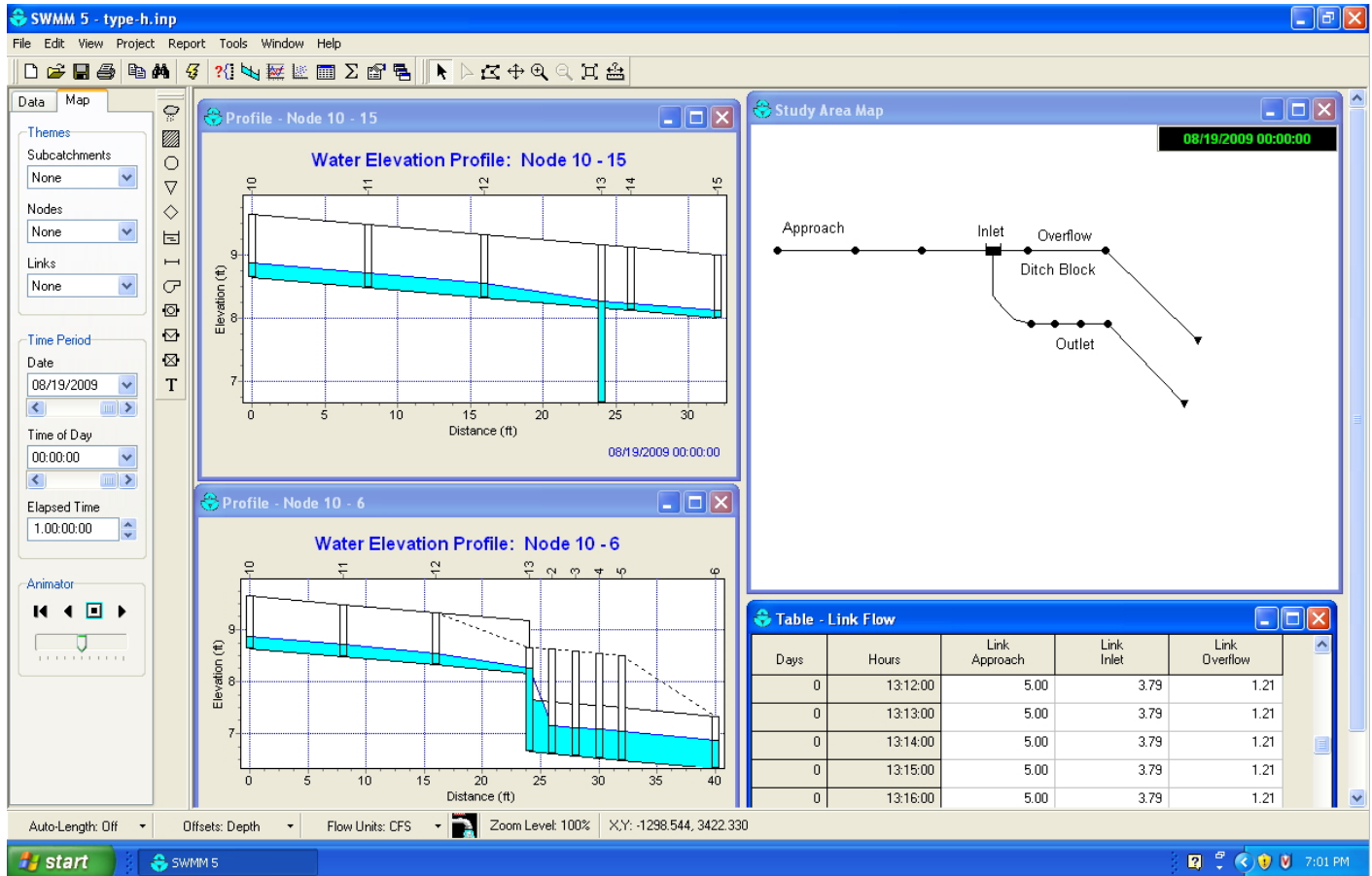

Figure 42: SWMM simulation results for the example conditions. The table in the lower left hand corner of the image contains the discharge values in the three different parts of the system: approach, inlet, and overflow.

6.2 Type-H Inlet Performance Prediction, Sag Conditions

Sag conditions represent the case where an inlet would be placed at grade or in a drainage ditch, and the inlet is located in a substantial sump. A ditch-block or other physical structure to increase flow depth above the inlet would be present if the sump is not a local topographic minimum.

Performance prediction is possible using HEC-22 and the weir equation within that document, however overflow conditions are difficult to predict. This difficulty was the main motivation behind using SWMM as a prediction tool for inlet performance prediction. The power-law model, like HEC-22, confers some prediction capability, but also shares the problematic issue of overflow prediction.

The remainder of this subsection presents illustrative examples of performance prediction using each technology.

6.2.1 Performance Prediction using HEC-22 in Sag Conditions

HEC-22 sag condition performance prediction is accomplished using HEC-22 Chart 9 or the weir flow equation. For the next three illustrative examples, the conditions of experiment #251 are used as the observational comparison values. In this experiment a ditch block was present and its height was 0.5 feet.

The physical conditions are as follows.

1. $Q_A = 3.58$ cfs. ; The approach discharge.
2. $S_0 = 0.02$; Longitudinal slope.
3. $S_X = 0.16$; Transverse slope. In HEC-22 parlance this condition is a 1:6 side slope.
4. $B = 2$ feet. Bottom width of the trapezoidal channel.
5. $Z = 6$; Side slope “run” (i.e. $S_X = \frac{1}{Z}$)
6. $W_I = 2$ feet. Inlet width.
7. $L_I = 2$ feet. Inlet length (along the long axis of the channel).
8. $n = 0.011$. Roughness coefficient (Manning’s n). This value is reflective of the experimental conditions and represents the lower range of values for float-finished concrete as reported in Chin (2006).

The HEC-22 approach is outlined as follows.

1. Specify the inlet perimeter, in this case $P = 8$ feet.
2. Specify the approach flow depth, which would be the block height.
3. Then enter Chart 9 (next or facing page) with depth on the left axis, and locate the intersec-

tion with depth and the $P = 8$ curve. The value of discharge associated with this intersection is the HEC-22 estimate of the upper limit of the inlet capacity at the specified flow depth, in this example, $Q_{I_{max}} = 8.0$ cfs.

CHART 9B

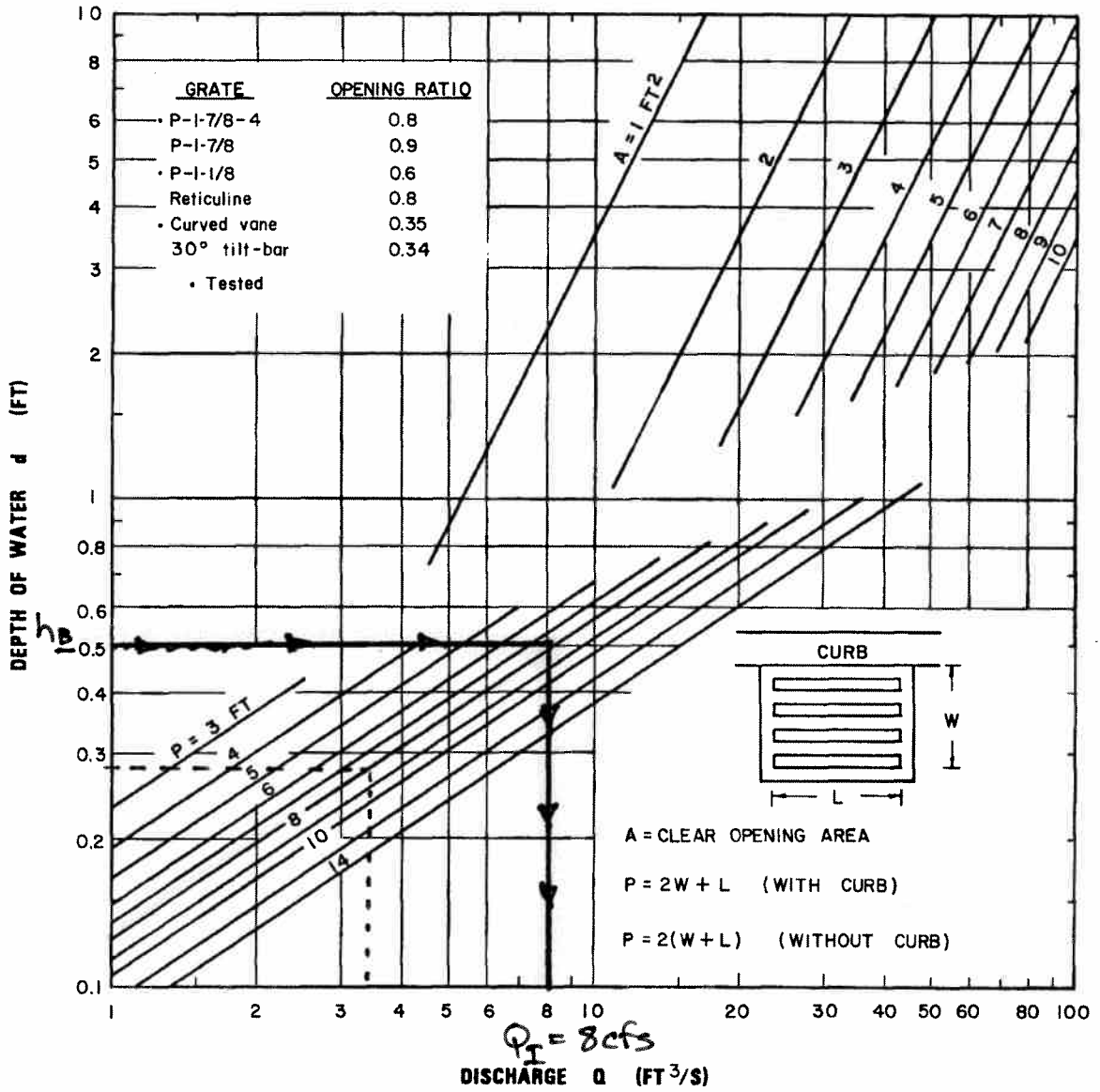

Grate Inlet Capacity in Sump Conditions - English Units

4. Compute capture as the difference of the approach flow and the inlet capacity value. If the difference is less than zero, then complete capture is anticipated. The approach flow for this example is only $Q_A = 3.60$ cfs, thus the analyst would conclude complete capture. Furthermore, the chart suggests that the flow depth at the inlet for the actual approach flow value would be $D_A = 0.28$ feet. The observed flow depth for this experiment approaching the inlet was 0.204 feet.

Two comments are important in HEC-22 sag condition estimation. First, chart 9 has two portions, the lower left hand corner used in the example is a graphical representation of the weir equation, while the upper right corner is the graphical representation of the orifice equation. While we never observed orifice flow, the chart suggests it occurs with relatively deep flow depths, beyond those we produced in our laboratory study. Second, the ditch block height in all our experiments was 0.5 feet, and using the approach illustrated here one would always predict complete capture, yet in many experiments overflow occurs.

6.2.2 Performance Prediction using Power-Law Model in Sag Conditions

The power-law model would the same series of computations as in the no-sag conditions with the understanding that it will under predict performance.

1. Specify approach discharge, Q_a . In this example $Q_a = 3.58$ cfs.
2. Determine the approach flow depth, D using an appropriate tool (Chart 14, or equation 4-32 in HEC-22). For this case, $D = 0.197$ feet is used.
3. Determine approach flow cross sectional area, A . In this example, $A = 0.626$ ft²
4. Determine approach flow mean section velocity, $V = \frac{Q_a}{A}$. In this example, $V = 5.711$ ft /sec
5. Determine the approach Froude number, $Fr = \frac{V}{\sqrt{gD}}$. In this example, $Fr = \frac{5.711}{\sqrt{32.2(0.197)}} = 2.267$.
6. Determine the depth to inlet width ratio, $\frac{D}{W}$, where W is the width of the inlet.³¹ In this example (to compare with experimental results), $\frac{D}{W} = \frac{0.197}{2.0} = 0.098$.
7. Determine the inlet length to depth ratio, $\frac{L}{D}$, where L is the length of the inlet. In this example (to compare with experimental results), $\frac{L}{D} = \frac{2}{0.197} = 10.16$.
8. Determine the inlet aspect ratio, $\frac{W}{L}$. Typically the aspect ratio will be unity (square inlets). In this example the aspect ratio is unity.
9. Compute the inlet capture discharge from Equation 12

$$Q_i = 10^{-0.624691} (3.58)^{1.08059} (2.267)^{-0.316764} (0.098)^{-0.192712} (10.16)^{0.301354} (1)^{0.18386} \quad (12)$$

This equation evaluates to $Q_I = 2.28$. The observed inlet flow was $Q_{I-observed} = 3.58$ cfs. The observed approach depth was 0.204 feet. In this example complete capture was actually observed, so the power-law model has under-predicted performance by about 36%.

³¹For Type-H the width will be between 3 and 5 feet.

6.2.3 Performance Prediction using SWMM in Sag Conditions

A SWMM model for performance prediction is exactly the same model as in the No-Sag example except the invert elevation of the node immediately downstream of the inlet is raised to represent the ditch block (and the approach discharge is changed to reflect the different experiment). Otherwise the model is geometrically identical as before.

Figure 43 is a screen capture of the simulation.

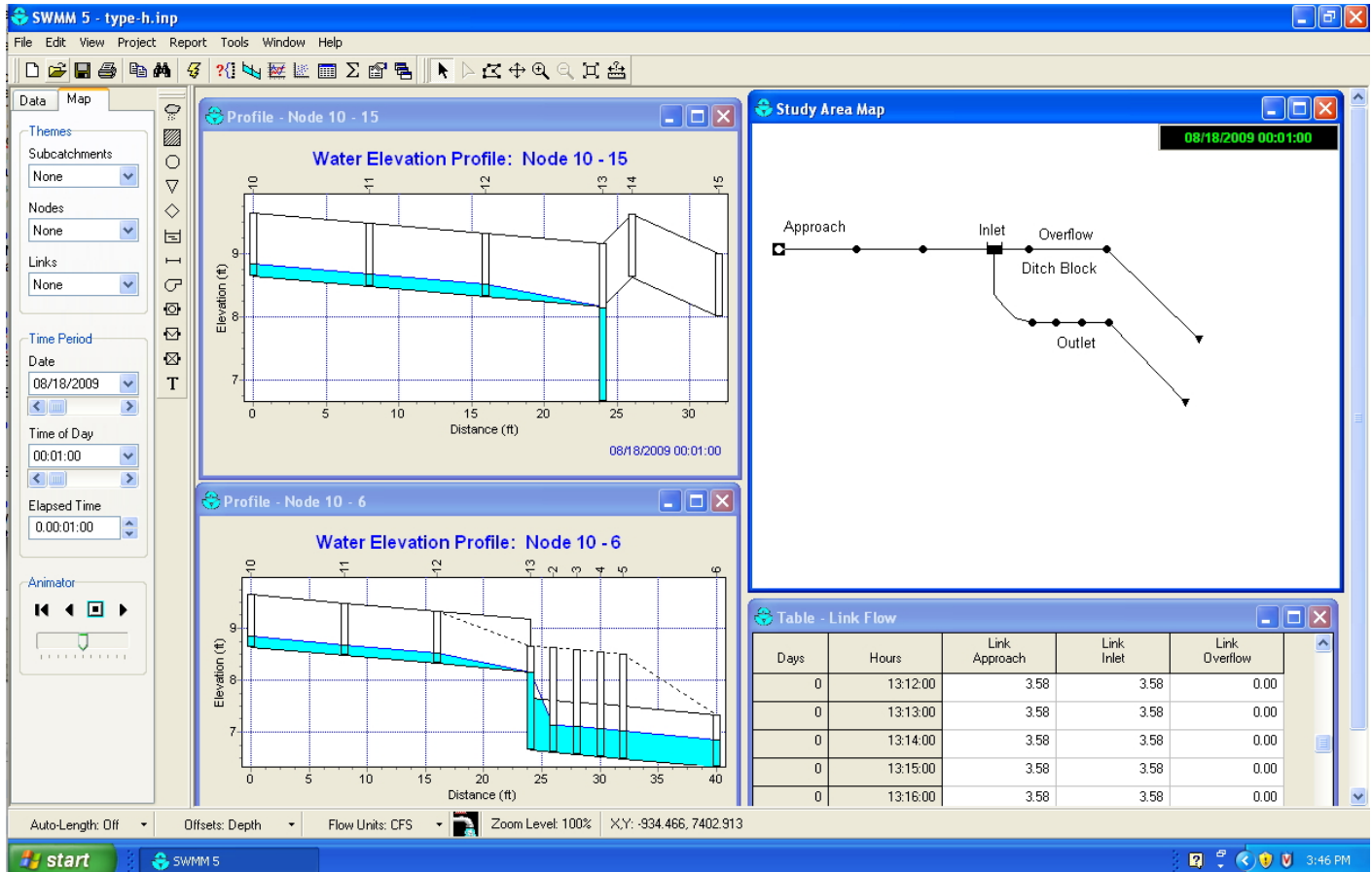

Figure 43: SWMM simulation results for sag conditions. Only the invert elevation of the node just downstream of the inlet is changed, the remainder of the model geometry is unchanged.

In this example, the modeled inlet achieves complete capture (zero overflow discharge), as was observed in the experiment.

6.2.4 Performance Prediction using SWMM in Sag Conditions, partial capture

As an illustration of SWMM for partial capture in the sag condition, the model is adjusted to the conditions of experiment #208.

In this experiment the approach discharge is $Q_A = 2.52$ cfs, and the inlet is a 1X1 square foot inlet.

The physical conditions are as follows.

1. $Q_A = 2.52$ cfs. ; The approach discharge.
2. $S_0 = 0.02$; Longitudinal slope.
3. $S_X = 0.16$; Transverse slope. In HEC-22 parlance this condition is a 1:6 side slope.
4. $B = 2$ feet. Bottom width of the trapezoidal channel.
5. $Z = 6$; Side slope “run” (i.e. $S_X = \frac{1}{Z}$)
6. $W_I = 1$ feet. Inlet width.
7. $L_I = 1$ feet. Inlet length (along the long axis of the channel).
8. $n = 0.011$. Roughness coefficient (Manning’s n). This value is reflective of the experimental conditions and represents the lower range of values for float-finished concrete as reported in Chin (2006).

Of importance, the inlet is a 1X1 square foot inlet. The SWMM model was adjusted by changing the approach discharge value to $Q_A = 2.52$ cfs, the inlet node area coefficient to 0.6, and the outlet pipe dimension was changed to $\frac{8}{12}$ feet. All other values in the program were left unchanged. The observed inlet flow was $Q_I = 1.98$ cfs, and the observed approach depth was 0.14 feet. The SWMM model result for the experimental conditions was $Q_{I\text{model}} = 2.09$ cfs, and $D_{A\text{-model}} = 0.19$ feet.

The power-law model for the conditions of experiment #208 predicts $Q_{I\text{model}} = 1.72$ cfs. The HEC-22 model for the conditions of experiment #208 predicts complete capture, $Q_{I\text{model}} = 2.52$ cfs.

7 Summary, Conclusions, and Suggestions

Texas Department of Transportation, Type-H drop inlets were examined using a combination of literature-derived-data, and physical model studies conducted at Texas Tech University using a purpose-built experimental apparatus, to evaluate anticipated performance of such inlets. Both primary morphologies; the grate-top and lid-top inlet were examined as were a handful of tandem inlet configurations. Experiments in sump or sag conditions as well as on-grade conditions were conducted.

7.1 Summary

The literature-derived results were compared to the physical model experiments conducted at Texas Tech University. Both sets of data (literature-derived and experimentally determined) were analyzed using HEC-22 procedures and regression analysis to produce guidance for predicting inlet hydraulic capacity. Additionally, the U.S. EPA SWMM model was used to analyze selected experimental results in an effort to develop guidance for using that tool as an alternate performance prediction method.

The researchers found that the TTU experiments were consistent with similar experiments found in the literature with respect to inlet capture capacity and its relationship to approach conditions. Type-H inlets, as studied, performed similar to HEC-22 expectations when the weir-type conditions are assumed (Equation (4-26) in HEC-22). The TTU researchers were unable to produce sufficient approach depth for orifice-type flow equations to explain observed behavior³².

Power-law models using the dimensionless groups identified by Cassidy (1966), with the slopes omitted, provided a reasonable explanation of inlet behavior. The model was fit using the TTU experiments then extrapolated to the literature-derived conditions, with reasonable fidelity to the literature-derived results. Likewise, when fit to the literature-derived conditions, then extrapolated to the TTU experimental conditions, reasonable fidelity to the experimental observations was preserved. The power-law model, because it is regression derived and, tends to under predict inlet capacity in cases where the inlets are known to achieve full capture. As such it [the power-law model] can be considered a lower-support prediction tool for inlet design.

The U.S. EPA SWMM program was investigated as a predictive tool by comparison of a simplified SWMM model to selected TTU experimental results. The modeling approach used predicted performance reasonably well. The SWMM model was perceived by the researchers better at predicting when full-capture would occur, but at the expense of having a minor-loss coefficient that reflected a throttle plate which certainly would not be used in practice³³.

A set of example applications was presented in the previous chapter to illustrate that HEC-22

³²The researchers speculate that that orifice flow in Type-H applications is less common than originally thought. The researchers believe that orifice flow begins when the approach flow depth is at least one inlet diameter equivalent, if not several inlet diameter equivalents or greater.

³³At least not intentionally.

procedures applied to experimental conditions reasonably explained those conditions; the same examples using SWMM application also appeared.

7.2 Conclusions

Considering collectively the findings and experimental conditions the researchers conclude:

1. Type-H inlets, whether grate-top or lid-type will behave according to the HEC-22 weir-type equations under most operational conditions until the approach depth is sufficiently deep — the researchers speculate that the requisite depth is on the order of the inlet equivalent diameter (i.e. the short dimension on a rectangular inlet). A six-inch ditch block, as suggested in the HEC-22 document to increase ponding and hence capture efficiency may not be sufficiently tall in many cases. The TTU experiments suggest that greater heights may be more appropriate.
2. Type-H inlet performance can be predicted using the HEC-22 methods as outlined in the previous chapter.
3. Type-H inlet performance can be predicted using the power-law model, with the caveat that the power law model does not predict full capture; even in cases where it might occur.
4. Type-H inlet performance can be predicted using SWMM modeling procedures. The ability of the analyst to directly code inlet performance into SWMM was not used in this research; the SWMM performance prediction was based on strictly hydraulic considerations.

7.3 Suggested Design Approach

A suggested approach to predicting inlet performance to support inlet design activities is as follows.

1. Determine if the performance prediction is to be applied in a Sag or No-Sag condition. The differences in the two conditions are discussed in the HEC-22 document. A No-Sag condition would be cases similar to those depicted in Figure 1 (left panel), Figure 2 without the ditch block, or Figure 10.
2. If the inlet is to be used in No-Sag condition, the existing HEC-22 approach is adequate and reasonably predictive of Type-H performance, bearing in mind that the inlet will behave according to the weir-type equations associated with the inlet. Starting with an estimate of approach discharge, the analyst will use the following:
 - (a) Chart 14B is used as illustrated to compute approach depth.
 - (b) Chart 5B and 6B are used to compute the frontal and side flow efficiency.
 - (c) As a check, the power-law model uses the same kind of design data. The numerical results of either approach should be within 10-15% of each other.

- (d) Detailed examples are presented in the previous chapter.
3. If the inlet is to be used in a Sag condition, the existing HEC-22 sag chart is appropriate but probably over-predicts performance, especially with respect to complete capture. Starting with an estimate of approach discharge, the analyst will use the following:
 - (a) Chart 14B is used as illustrated to compute approach depth.
 - (b) Chart 9B is used to compute the inlet total capacity using the lower-left hand portion (weir) of the chart.
 - (c) As a check, the power-law model uses the same kind of design data. The power-law model is known to under-predict (predicts less capture than actually would occur in a sag condition) performance and should be viewed as such.
 - (d) Detailed examples are presented in the previous chapter.

A SWMM model is a promising supplementary tool and could be considered, but not in the absence of using the HEC-22 methods. The SWMM approach is attractive for sag conditions or ditch-block in a median. The SWMM methods described in previous sections can predict ditch-block overflow and provide the analyst with guidance for accommodating such flow, HEC-22 lacks clarity in the overflow prediction case.

7.4 Suggested Future Research

Future research includes addressing experimental difficulties experienced at TTU and two fundamental shortcomings. An implementation project is suggested based on this research although at least one field study should be conducted before the suggested implementation study.

1. The physical model used in this study had limited vertical drop beneath the inlet. Prior studies appear to have substantial (and hence no outlet restrictions) drop, yet perform similarly. Future studies involving vaults connected to a drainage pipe should be operated with sufficient vertical dimension to convincingly determine the performance attributed to the inlet and grate as opposed to the restrictions imposed by the downstream boundary conditions.
2. The physical model used in this study had limited flow depth capability to such an extent that orifice-type flow could not be achieved.³⁴ Future researchers should, if possible, generate deep flows (2 times greater than the inlet diameter) to evaluate if orifice flow does indeed occur in drainage inlets.
3. There are drop inlets morphologically similar to the Type-H inlets in this study in service in Texas. A subset should be identified and field instrumented. The instrumentation would involve the placement of a SonTek, uplooking Argonaut ADCP (or similar instrument) downstream of an inlet, in the drainage pipe. A digital video recorder, triggering circuit, and depth logger in the approach channel would also be required. Collectively these instruments

³⁴More precisely, our deepest flows could not be explained by the orifice equation.

could detect and measure approach depth, approach discharge, and inlet capture in actual systems in an unattended mode. A dozen or so storms at three or four locations around the state should suffice to determine if the HEC-22 equations fit the actual behavior well, and if SWMM can indeed be used to predict full-scale behavior.

4. The SWMM modeling approach was explored late in the research program, however the results suggest that it (SWMM) is a plausible design tool for inlet design, especially as the sag conditions can be modeled in such a way as to faithfully capture some of the observed overflows. Further effort with this tool is warranted, a possible implementation project would be to perform SWMM modeling of all the experiments, including the literature derived results to determine the most meaningful node area reductions and outlet restriction losses to be applied to simulate inlet behavior. The researchers believe that grate differences are more negligible than suggested by HEC-22, and the concept of area reductions to reflect different grate types is also a reasonable and achievable goal.

The result of such an implementation project should be a modeling protocol to assist in inlet design (i.e. a model application recipe), and a set of tutorial examples to illustrate how to use SWMM (or HEC-RAS) to predict inlet performance. This implementation project should follow the field instrumentation project suggested above.

References

- Brown, S., S. Stein, and J. Warner (2001). *Urban Drainage Design Manual Hydraulic Engineering Circular 22* (Second Edition; FHWA-NHI-01-021 ed.). Washington, D.C.: Federal Highway Administration.
- Burgi, P. H. (1978a). Bicycle-safe grate inlets study, volume-2 hydraulic characteristics of three selected grate inlets on continuous grades. Research Report FHWA-RD-78-4, Federal Highway Administration.
- Burgi, P. H. (1978b). Bicycle-safe grate inlets study, volume-3 hydraulic characteristics of three selected grate inlets in a sump condition. Research Report FHWA-RD-78-70, Federal Highway Administration.
- Burgi, P. H. and D. E. Gober (1978). Hydraulic and safety characteristics of selected grate inlets. *TRB Research Record* (No. 685).
- Cassidy, J. J. (1966). Generalized hydraulic characteristics of grate inlets. *Highway Research Board Record No. 123*, 36–48.
- Chin, D. A. (2006). *Water-Resources Engineering* (2nd. Edition ed.). Prentice-Hall.
- Kranc, S. C. (2000). Hydraulic performance of several curb and gutter inlets. Research Report Final Report BB-895, Florida Department of Transportation.
- Kranc, S. C. and M. W. Anderson (1993). Investigation of discharge through grated inlets. Research Report Report No. 611, Florida Department of Transportation, Office of Research Management.
- Larson, C. L. (1947). Investigation of flow through standard and experimental grate inlets for street gutter. Research Report Project Report No. 3, University of Minnesota St. Anthony Falls Hydraulic Laboratory.
- Larson, C. L. (1948). Experiments on flow through inlet gratings for street gutters. Research Report No. 6-B, Highway Research Board, Washington, D. C.
- McEnroe, B. M., R. P. Wade, and A. K. Smith (1999). Hydraulic performance of curb and gutter inlets. Research Report KU-99-1, Kansas Department of Transportation.
- Pugh, C. A. (1980). Bicycle-safe grate inlets study, volume 5 - hydraulic design of general slotted drain inlets. Research Report FHWA/RD-80/081, Federal Highway Administration.
- Reba, I. (1966). Applications of the coanda effect. *Scientific American* 66(13), 1966–1995.
- Rossman, L. (2008). Storm water management model user's manual version 5.0. Technical Report EPA/600/R-05/040, U.S. Environmental Protection Agency.
- TRB (1969). Traffic-safe and hydraulically efficient drainage practices. Synthesis Report NCHRP Synthesis of Highway Practice 3, Transportation Research Board, Washington, D.C.

Wahl, T. L. (1995, August 14-18). Hydraulic testing of self-cleansing inclined screens. In *First International Conference on Water Resources Engineering*, San Antonio, Texas. American Society of Civil Engineers.

Woo, D. and J. Jones (1974). Hydraulic characteristics of two bicycle-safe grate inlet designs. Research Report FHWA-RD-74-77, Federal Highway Administration, U.S. Department of Transportation, Washington, D.C.

8 Appendix-I Texas DOT Type-H Inlet Drawings

This appendix contains two sets of drawings (4 sheets total).

The next two sheets are Type-H Inlet with grate top (IL-H-G).

- ① May be changed as directed by the Engineer.
- ② D equals the maximum inside diameter of any pipe entering the wall shown on the opposite wall.
- ③ D equals the maximum inside diameter of any pipe entering the inlet.

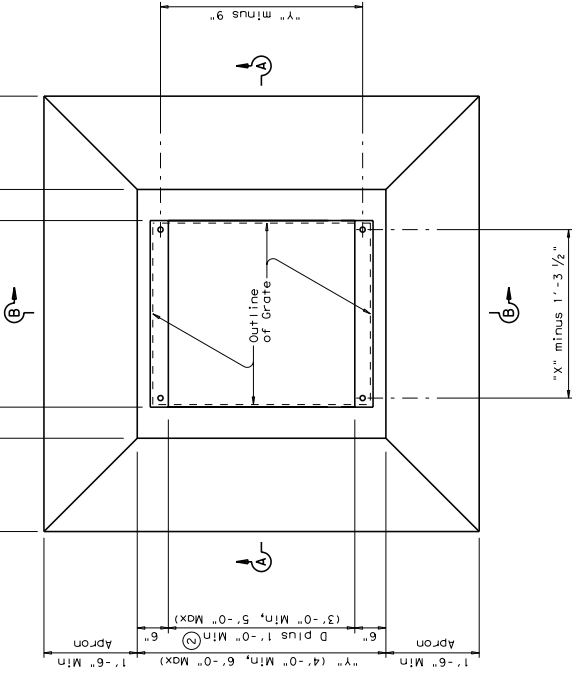

PLAN

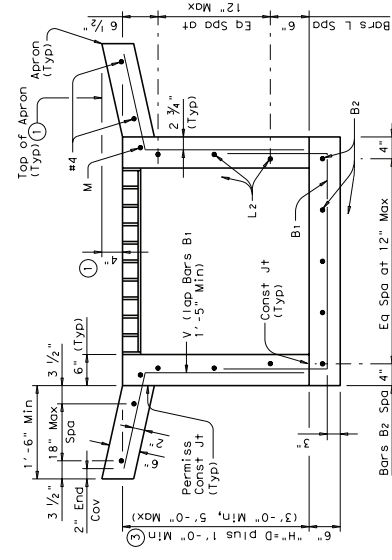

SECTION A-A

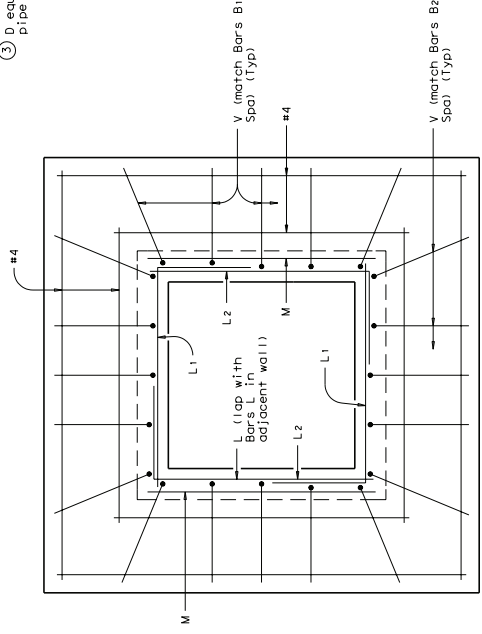

TYPICAL APRON PLAN
(Showing reinforcing in walls and in apron)

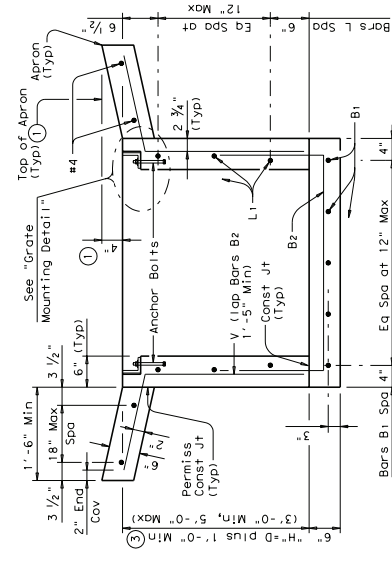

SECTION B-B

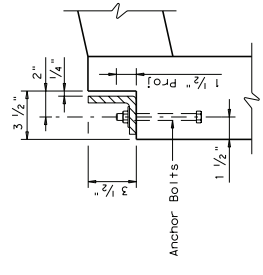

GRATE MOUNTING DETAIL

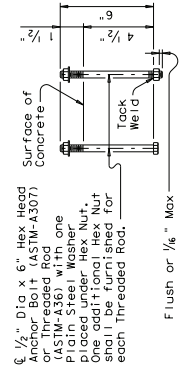

ANCHOR BOLT OPTIONS

SHEET 1 OF 2



**HORIZONTAL INLET
TYPE H WITH GRATE
(MAX 48" DIA PIPES)**

IL-H-G

FILED	1/18/2011	gpn	TxDOT	CH	TxDOT	CH	TxDOT
REVISIONS							

DISCLAIMER: The use of this standard is governed by the Texas Engineering Practice Act. No warranty of any kind is made by TxDOT for any purpose whatsoever. TxDOT assumes no responsibility for the conversion of this standard to other formats or for incorrect results or damages resulting from its use.

Angle of entry is less than or equal to 10°

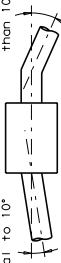

PIPE CONNECTION DETAIL

Connecting pipes should enter within 10° of perpendicularity. If a pipe is to be installed at an angle, a curved approach alignment should be used to stay within this limit.

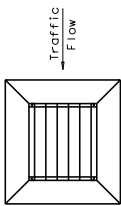

GRATE ORIENTATION DETAIL

If possible, horizontal grate inlet should be oriented such that both traffic and drainage flow are in the same direction. If this is not possible, orientation must favor traffic flow. Grate is not to be used under direct traffic; rather, it is to be used in ditches and medians away from the roadway.

GENERAL NOTES:

- When approved, precast inlets with equivalent strength may be furnished. Sealed engineering calculations and drawings shall be submitted for approval prior to construction. Shop drawings will not be required.
- In areas of conflict between reinforcing steel, blockouts, pipes, anchor bolts or other reinforcing steel, the reinforcement shall be Engineer adjusted to clear as directed by the Engineer.
- Anchor Bolts are 1/2" Dia ASTM A307 Grade A bolts (or A36 threaded rods with one hex head nut and one hex head nut each) with one hex head nut and one precast nut.
- Structural Steel for grates shall conform to the requirements of ASTM Designation A-36 or A572.
- Reinforcing steel shall be Grade 60 unless otherwise noted.
- All steel components except reinforcing, shall be galvanized after fabrication.
- Galvanizing damaged during transport or installation shall be repaired in accordance with the specifications.
- All concrete shall be Class "A" (f'c = 3,000 psi).



BARS V (#4)

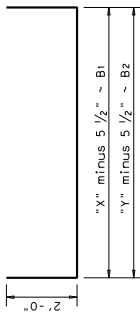

BARS B (#4)

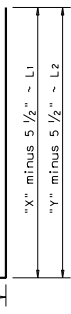

BARS L (#4)

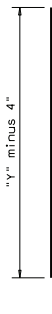

BARS M (#4)

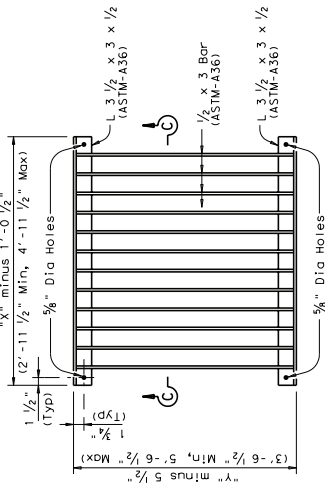

TYPICAL GRATE PLAN

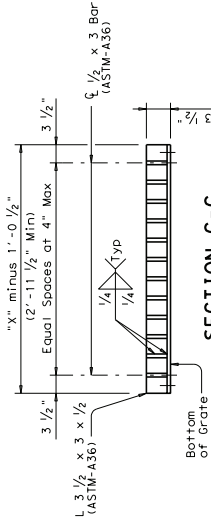

SECTION C-C



**HORIZONTAL INLET
TYPE H WITH GRATE
(MAX 48" DIA PIPES)**

IL-H-G

FILE: I1HSEIL-099	DN: TXDOT	CH: TXDOT	DM: TXDOT	CH: TXDOT
TXDOT	FEBRUARY 2010	DISTRICT	FEDERAL AID PROJECT	SHEET
REVISIONS				
		COUNTY	CONTROL SECT	RDWAY

DISCLAIMER: Use of this standard is governed by the Texas Engineering Practice Act. No warranty of any kind is made by TXDOT for any purpose whatsoever. TXDOT assumes no responsibility for the conversion of this standard to other formats or for incorrect results or damages resulting from its use.

DATE:

LETTERS 019R4A80

1

The next two sheets are Type-H Inlet with lid top (IL-H-L).

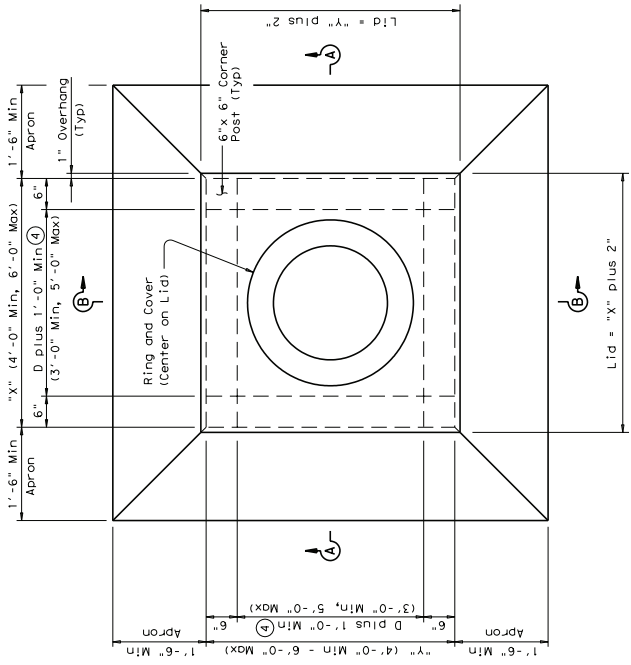

PLAN

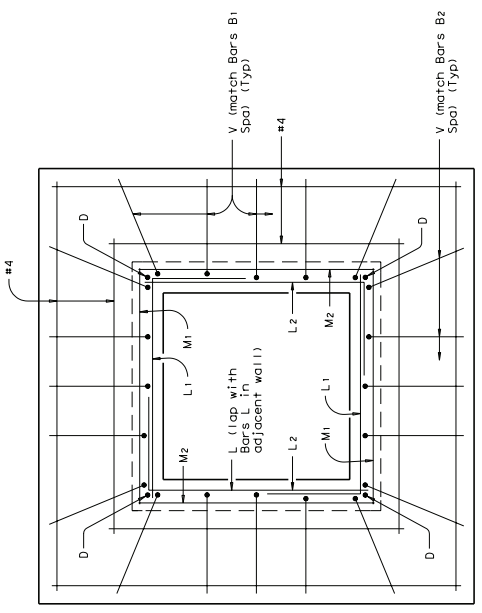

TYPICAL APRON PLAN

(Lid not shown for clarity. Showing reinforcing in walls and in apron.)

- 1 May be changed as directed by the Engineer.
- 2 Place layer of grout between lid and corner posts to provide stable seating of lid.
- 3 Center Dowels D in corner posts. (Typ)
- 4 D equals the maximum inside diameter of any pipe entering the wall shown or the opposite wall.
- 5 D equals the maximum inside diameter of any pipe entering the inlet.

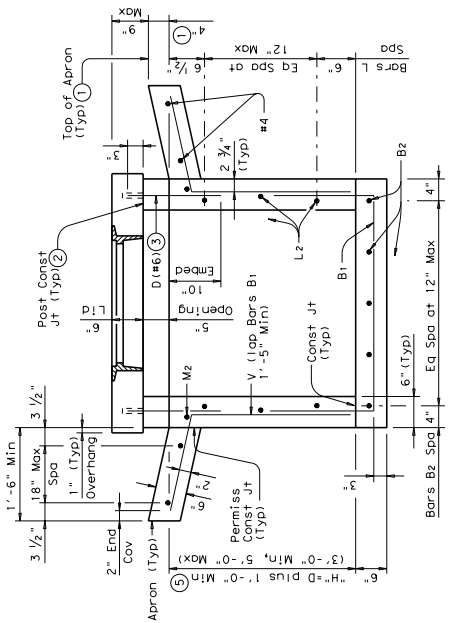

SECTION A-A

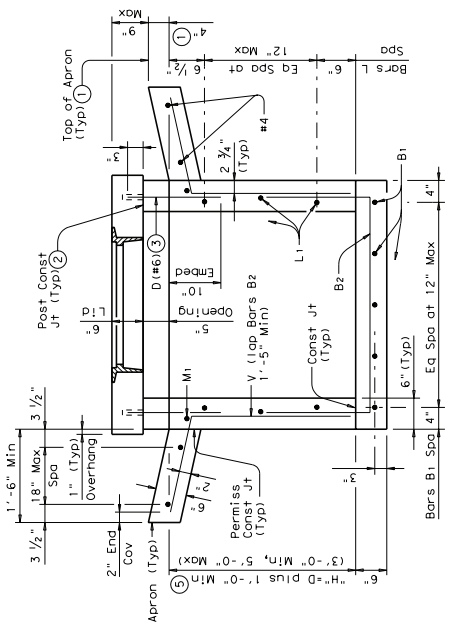

SECTION B-B



**HORIZONTAL INLET
TYPE H WITH LID
(MAX 48" DIA PIPES)**

IL-H-L

FILE	11ns1802.dgn	DW	TxDOT	Ch	TxDOT	DW	TxDOT	Ch	TxDOT
PROJECT	FEDERAL AID PROJECT								
DATE	FEBRUARY 2010								
REVISIONS									
COUNTY									
CONTROL									
SECTION									
JOB									
ROADWAY									

DISCLAIMER:
This standard is governed by the Texas Engineering Practice Act. No warranty of any kind is made by TxDOT for any purpose whatsoever. TxDOT assumes no responsibility for the conversion of this standard to other formats or for incorrect results or damages resulting from its use.

1									

LEVEES 019RA480

PATH:

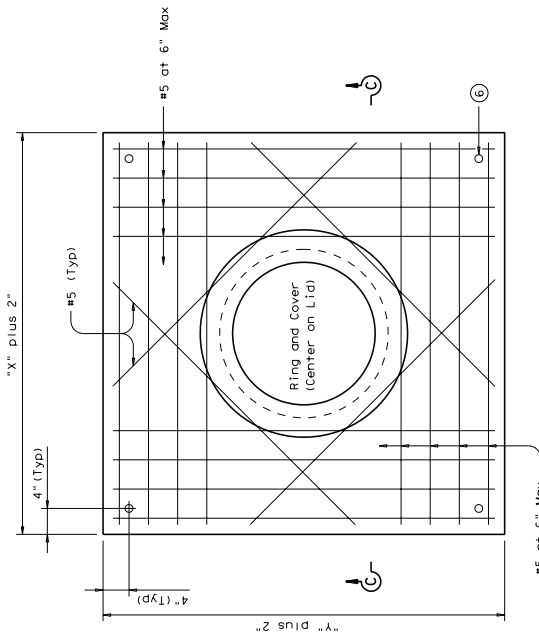

TYPICAL PRECAST LID PLAN

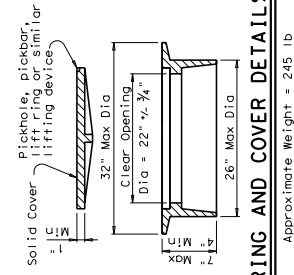
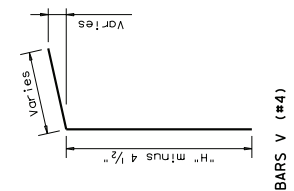
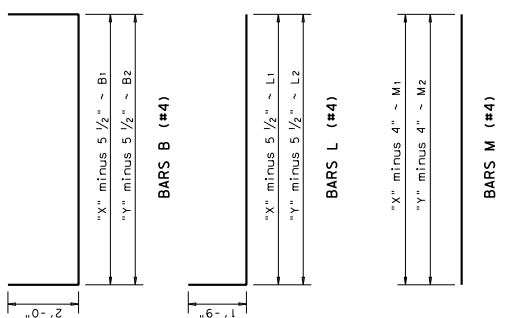

Approximate Weight = 245 lb

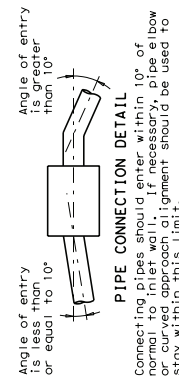

PIPE CONNECTION DETAIL

Connecting pipes should enter within 10° of vertical. If the angle of entry is less than or equal to 10°, the angle of entry is greater than 10°. Curved approach alignment should be used to stay within this limit.

SECTION C-C

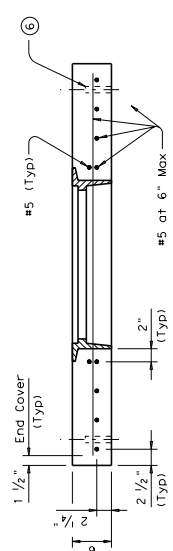

Form notes in lid for Dowels D using 1" Dia x 4" PVC Pipe (SCH 40) (Typ)

GENERAL NOTES:
 When approved, precast inlets with equivalent strength shall be furnished. Sealed engineering calculations and drawings shall be submitted for approval prior to construction. Shop drawings will not be required.
 All reinforcement shall be placed in place. Lid will be precast in place.
 In areas of conflict between reinforcing steel, blockouts, pipes, anchor bolts or other items in cast steel, the reinforcement shall be bent or adjusted to clear as directed by the Engineer.
 Structural steel for grates shall conform to the requirements of ASTM Designation A-36 or A-572, Grade 50, unless otherwise noted.
 All reinforcing steel shall be Grade 60 unless otherwise noted.
 All concrete shall be Class "A" (f'c = 3,000 psi).
 All reinforcement exposed to weathering shall be galvanized or galvanized after fabrication. Galvanizing damaged during transport or construction shall be repaired in accordance with the specifications.
 Inlets shall be placed in ditches and medians away from the roadway.

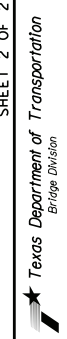

**HORIZONTAL INLET
 TYPE H WITH LID
 (MAX 48" DIA PIPES)**

IL-H-L

FILE #	11HS1602-00p	DR	TXDOT	CH	TXDOT	DR	TXDOT	CH	TXDOT
DATE	FEBRUARY 2010	DISPACT	FEDERAL AID PROJECT	REVISIONS	COUNTY	CONTROL	SECT	JOB	RDWAY

9 Appendix-II Literature Derived Performance Database

The literature review identified previous studies of inlet hydraulics that might be relevant to the Type-H studies. Performance data from these prior studies were extracted to build an analytical database to examine inlet performance and to compare current (Texas Tech experiments) results. These prior studies contained 43 identifiable inlet configurations of various dimensions. These 43 prior studies were each assigned a record identifier for further manipulation. Table 4 lists the identification codes, and the relevant source of data used in the comparative components of the Type-H research.

These prior studies appeared to be conducted without outlet restriction, that is the inlet itself was the limiting performance component. The Texas Tech studies (reported elsewhere in this report) were intentionally outlet restricted for a portion of the configurations, in part to examine what effect the outlet location relative to the inlet vault box invert elevation might have in a full-scale system. These studies [including the Texas Tech effort] span nearly 60 years of experiments and ideas have changed over this interval, hence some values were directly reported in the literature while others are derived from experimental description and the data provided in the particular experiment report.

Table 5 is a list of the performance values extracted and/or derived by calculation from the literature sources listed in Table 4.

Table 4: Cross-Reference Source Identification for Literature-Derived Performance Data for Drop-Type Inlets.

[ID-CODE: A record identifying code to relate literature source and model type to tabulated performance data; REF-CODE: A code that identifies the data source; TYPE: A code that identifies the model type; CITATION: The citation for the literature source.

ID-CODE	REF-CODE	TYPE	CITATION
LIT-1	FHWA-RD-74-77	ORE-L	Woo and Jones (1974)
LIT-2	FHWA-RD-74-77	ORE-T	Woo and Jones (1974)
LIT-3	FHWA-RD-74-77	TB45-1	Woo and Jones (1974)
LIT-4	FHWA-RD-74-77	TB45-3	Woo and Jones (1974)
LIT-5	FHWA-RD-74-77	MASS	Woo and Jones (1974)
LIT-6	FHWA-RD-74-77	TB45-5	Woo and Jones (1974)
LIT-7	FHWA-RD-74-77	TBV-5	Woo and Jones (1974)
LIT-8	FHWA-RD-74-77	TBV-3	Woo and Jones (1974)
LIT-9	FHWA-RD-78-4	P -1-1/8	Burgi (1978a)
LIT-10	FHWA-RD-78-4	P - 1-7/8 -4	Burgi (1978a)
LIT-11	FHWA-RD-78-4	CV -3-1/4 - 4-1/4	Burgi (1978a)
LIT-12	FHWA-RD-80/081	Slotted Drain	Pugh (1980)
LIT-13	FHWA-RD-78-70	P - 1-1/8 Sump	Burgi (1978b)
LIT-14	FHWA-RD-78-70	P - 1-1/8 - 4	Burgi (1978b)

Continued on next page

Table 4: Type-H Experiments — Continued

ID-CODE	REF-CODE	TYPE	CITATION
LIT-15	FHWA-RD-78-70	CV - 3-1/4 - 4-1/4	Burgi (1978b)
LIT-16	Cassidy	C	Cassidy (1966)
LIT-17	Cassidy	E	Cassidy (1966)
LIT-18	Cassidy	F	Cassidy (1966)
LIT-19	Cassidy	A	Cassidy (1966)
LIT-20	Cassidy	B	Cassidy (1966)
LIT-21	Cassidy	D	Cassidy (1966)
LIT-22	Cassidy	C	Cassidy (1966)
LIT-23	Cassidy	E	Cassidy (1966)
LIT-24	Cassidy	F	Cassidy (1966)
LIT-25	Univ. of MN	Series A	Larson (1947)
LIT-26	Univ. of MN	Series B	Larson (1947)
LIT-27	Univ. of MN	Series C	Larson (1947)
LIT-28	Univ. of MN	Series D	Larson (1947)
LIT-29	Univ. of MN	Series E	Larson (1947)
LIT-30	Univ. of MN	Series F	Larson (1947)
LIT-31	Univ. of MN	Series G	Larson (1947)
LIT-32	Univ. of MN	Series H	Larson (1947)
LIT-33	Univ. of MN	Series J	Larson (1947)
LIT-34	Univ. of MN	Inlet K	Larson (1947)
LIT-35	Univ. of MN	Inlet L	Larson (1947)
LIT-36	Univ. of MN	Inlet M	Larson (1947)
LIT-37	Univ. of MN	Inlet N	Larson (1947)
LIT-38	Univ. of MN	Inlet P	Larson (1947)
LIT-39	KDOT	B	McEnroe et al. (1999)
LIT-40	KDOT	12	McEnroe et al. (1999)
LIT-41	KDOT	22-1.5	McEnroe et al. (1999)
LIT-42	KDOT	22-3.0	McEnroe et al. (1999)
LIT-43	KDOT	22-4.5	McEnroe et al. (1999)

Table 5: Literature-Derived Performance Data for Drop-Type Inlets.

[ID-CODE, Experiment identification number; Q_A , Approach discharge (cubic feet per second); Q_I , Inlet discharge (cubic feet per second); Q_O , overflow discharge (cubic feet per second); Q_R , capture ratio ($\frac{Q_I}{Q_A}$); S_0 , Longitudinal slope; S_x , Channel side slope; d_a , approach depth (feet); h_b , ditch block height (feet); L_I , inlet length (feet); W_I , inlet width (feet); L_R , length to depth ratio ($\frac{L_I}{d_a}$); W_R , depth to width ratio ($\frac{d_a}{W}$); Fr , Froude number]

ID-CODE	Q_A	Q_I	Q_O	Q_R	S_0	S_x	d_a	h_b	L_I	W_I	L_R	W_R	Fr
LIT-1	2.27	1.75	0.52	0.77	0.005	0.040	0.26	0.00	2.56	1.67	9.88	0.16	0.94
LIT-1	2.58	1.92	0.66	0.74	0.005	0.040	0.27	0.00	2.56	1.67	9.48	0.16	0.96
LIT-1	2.99	2.10	0.89	0.70	0.005	0.040	0.29	0.00	2.56	1.67	8.86	0.17	0.94
LIT-1	3.38	2.26	1.13	0.67	0.005	0.040	0.30	0.00	2.56	1.67	8.42	0.18	0.94
LIT-1	3.87	2.43	1.44	0.63	0.005	0.040	0.32	0.00	2.56	1.67	7.98	0.19	0.94
LIT-1	4.30	2.59	1.70	0.60	0.005	0.040	0.33	0.00	2.56	1.67	7.85	0.20	1.00
LIT-1	0.75	0.74	0.01	0.99	0.010	0.040	0.13	0.00	2.56	1.67	19.25	0.08	1.63
LIT-1	1.05	1.01	0.04	0.96	0.010	0.040	0.16	0.00	2.56	1.67	16.31	0.09	1.52
LIT-1	1.62	1.45	0.17	0.90	0.010	0.040	0.19	0.00	2.56	1.67	13.33	0.11	1.42
LIT-1	2.30	1.90	0.40	0.83	0.010	0.040	0.22	0.00	2.56	1.67	11.80	0.13	1.48
LIT-1	2.93	2.23	0.71	0.76	0.010	0.040	0.24	0.00	2.56	1.67	10.76	0.14	1.50
LIT-1	3.81	2.62	1.19	0.69	0.010	0.040	0.27	0.00	2.56	1.67	9.52	0.16	1.43
LIT-1	0.75	0.72	0.03	0.97	0.028	0.040	0.13	0.00	2.56	1.67	20.32	0.08	1.86
LIT-1	1.04	0.99	0.05	0.95	0.028	0.040	0.14	0.00	2.56	1.67	17.78	0.09	1.86
LIT-1	1.58	1.43	0.15	0.90	0.028	0.040	0.18	0.00	2.56	1.67	14.30	0.11	1.65
LIT-1	2.25	1.83	0.42	0.81	0.028	0.040	0.21	0.00	2.56	1.67	12.43	0.12	1.65
LIT-1	2.83	2.14	0.68	0.76	0.028	0.040	0.22	0.00	2.56	1.67	11.53	0.13	1.72
LIT-1	3.62	2.53	1.08	0.70	0.028	0.040	0.25	0.00	2.56	1.67	10.45	0.15	1.72
LIT-1	0.75	0.71	0.04	0.95	0.054	0.040	0.13	0.00	2.56	1.67	20.32	0.08	1.86
LIT-1	1.08	0.96	0.12	0.89	0.054	0.040	0.17	0.00	2.56	1.67	15.42	0.10	1.35
LIT-1	1.54	1.38	0.16	0.90	0.054	0.040	0.16	0.00	2.56	1.67	15.80	0.10	2.05
LIT-1	2.15	1.80	0.35	0.84	0.054	0.040	0.18	0.00	2.56	1.67	13.99	0.11	2.11
LIT-1	2.67	2.13	0.54	0.80	0.054	0.040	0.20	0.00	2.56	1.67	13.13	0.12	2.24
LIT-1	3.39	2.45	0.94	0.72	0.054	0.040	0.22	0.00	2.56	1.67	11.91	0.13	2.23
LIT-1	0.74	0.68	0.07	0.91	0.075	0.040	0.10	0.00	2.56	1.67	24.85	0.06	3.08
LIT-1	1.04	0.91	0.13	0.88	0.075	0.040	0.14	0.00	2.56	1.67	18.03	0.09	1.92
LIT-1	1.50	1.31	0.19	0.87	0.075	0.040	0.15	0.00	2.56	1.67	17.53	0.09	2.60
LIT-1	2.10	1.77	0.33	0.84	0.075	0.040	0.17	0.00	2.56	1.67	15.06	0.10	2.48
LIT-1	2.62	2.11	0.51	0.81	0.075	0.040	0.19	0.00	2.56	1.67	13.84	0.11	2.50
LIT-1	3.27	2.46	0.81	0.75	0.075	0.040	0.20	0.00	2.56	1.67	12.93	0.12	2.64
LIT-2	1.32	1.02	0.30	0.77	0.005	0.040	0.26	0.00	2.67	1.62	10.15	0.16	0.52
LIT-2	1.77	1.44	0.33	0.81	0.005	0.040	0.23	0.00	2.67	1.62	11.46	0.14	0.95

Continued on next page

Table 5: Literature-Derived Performance Data for Drop-Type Inlets — Continued

ID-CODE	Q_A	Q_I	Q_O	Q_R	S_0	S_x	d_a	h_b	L_I	W_I	L_R	W_R	Fr
LIT-2	2.27	1.67	0.59	0.74	0.005	0.040	0.26	0.00	2.67	1.62	10.31	0.16	0.94
LIT-2	2.58	1.80	0.77	0.70	0.005	0.040	0.27	0.00	2.67	1.62	9.93	0.17	0.97
LIT-2	3.41	2.05	1.36	0.60	0.005	0.040	0.31	0.00	2.67	1.62	8.67	0.19	0.91
LIT-2	4.31	2.35	1.96	0.54	0.005	0.040	0.33	0.00	2.67	1.62	8.17	0.20	0.99
LIT-2	0.51	0.50	0.02	0.97	0.010	0.040	0.13	0.00	2.67	1.62	20.38	0.08	1.16
LIT-2	0.75	0.69	0.06	0.92	0.010	0.040	0.13	0.00	2.67	1.62	20.86	0.08	1.79
LIT-2	1.06	0.91	0.15	0.86	0.010	0.040	0.16	0.00	2.67	1.62	17.01	0.10	1.52
LIT-2	1.63	1.29	0.33	0.79	0.010	0.040	0.19	0.00	2.67	1.62	13.83	0.12	1.40
LIT-2	2.29	1.65	0.64	0.72	0.010	0.040	0.22	0.00	2.67	1.62	12.36	0.13	1.49
LIT-2	3.88	2.16	1.72	0.56	0.010	0.040	0.28	0.00	2.67	1.62	9.60	0.17	1.34
LIT-2	0.28	0.26	0.02	0.95	0.028	0.040	0.09	0.00	2.67	1.62	30.69	0.05	1.74
LIT-2	0.75	0.64	0.10	0.86	0.028	0.040	0.13	0.00	2.67	1.62	21.02	0.08	1.83
LIT-2	1.04	0.86	0.18	0.83	0.028	0.040	0.14	0.00	2.67	1.62	18.54	0.09	1.86
LIT-2	1.58	1.23	0.35	0.78	0.028	0.040	0.18	0.00	2.67	1.62	15.08	0.11	1.69
LIT-2	2.25	1.54	0.71	0.68	0.028	0.040	0.21	0.00	2.67	1.62	12.96	0.13	1.65
LIT-2	3.64	1.96	1.68	0.54	0.028	0.040	0.25	0.00	2.67	1.62	10.81	0.15	1.69
LIT-2	0.28	0.23	0.04	0.84	0.054	0.040	0.08	0.00	2.67	1.62	35.13	0.05	2.44
LIT-2	0.75	0.58	0.17	0.78	0.054	0.040	0.13	0.00	2.67	1.62	20.23	0.08	1.66
LIT-2	1.08	0.77	0.30	0.72	0.054	0.040	0.17	0.00	2.67	1.62	16.08	0.10	1.35
LIT-2	1.53	1.07	0.46	0.70	0.054	0.040	0.16	0.00	2.67	1.62	16.79	0.10	2.14
LIT-2	2.15	1.31	0.84	0.61	0.054	0.040	0.18	0.00	2.67	1.62	14.51	0.11	2.09
LIT-2	3.38	1.67	1.71	0.49	0.054	0.040	0.21	0.00	2.67	1.62	12.48	0.13	2.25
LIT-2	0.28	0.23	0.05	0.83	0.075	0.040	0.07	0.00	2.67	1.62	37.08	0.04	2.80
LIT-2	0.74	0.52	0.22	0.70	0.075	0.040	0.11	0.00	2.67	1.62	25.19	0.07	2.86
LIT-2	1.04	0.69	0.34	0.67	0.075	0.040	0.14	0.00	2.67	1.62	18.54	0.09	1.86
LIT-2	1.50	0.90	0.60	0.60	0.075	0.040	0.15	0.00	2.67	1.62	18.41	0.09	2.64
LIT-2	2.11	1.18	0.93	0.56	0.075	0.040	0.17	0.00	2.67	1.62	15.43	0.11	2.38
LIT-2	3.30	1.56	1.74	0.47	0.075	0.040	0.20	0.00	2.67	1.62	13.15	0.13	2.51
LIT-3	2.26	1.77	0.49	0.78	0.005	0.040	0.26	0.00	2.62	1.67	10.16	0.15	0.94
LIT-3	2.59	1.96	0.63	0.76	0.005	0.040	0.27	0.00	2.62	1.67	9.67	0.16	0.95
LIT-3	3.00	2.14	0.85	0.72	0.005	0.040	0.29	0.00	2.62	1.67	9.03	0.17	0.93
LIT-3	3.39	2.31	1.08	0.68	0.005	0.040	0.31	0.00	2.62	1.67	8.56	0.18	0.92
LIT-3	3.85	2.52	1.34	0.65	0.005	0.040	0.32	0.00	2.62	1.67	8.24	0.19	0.95
LIT-3	4.30	2.73	1.56	0.64	0.005	0.040	0.33	0.00	2.62	1.67	8.04	0.20	1.00
LIT-3	2.02	1.78	0.24	0.88	0.010	0.040	0.21	0.00	2.62	1.67	12.72	0.12	1.47
LIT-3	2.30	1.96	0.34	0.85	0.010	0.040	0.22	0.00	2.62	1.67	12.07	0.13	1.48
LIT-3	2.62	2.16	0.46	0.82	0.010	0.040	0.23	0.00	2.62	1.67	11.49	0.14	1.49
LIT-3	2.95	2.32	0.62	0.79	0.010	0.040	0.24	0.00	2.62	1.67	10.87	0.14	1.46
LIT-3	3.42	2.53	0.89	0.74	0.010	0.040	0.26	0.00	2.62	1.67	10.12	0.16	1.41

Continued on next page

Table 5: Literature-Derived Performance Data for Drop-Type Inlets — Continued

ID-CODE	Q_A	Q_I	Q_O	Q_R	S_0	S_x	d_a	h_b	L_I	W_I	L_R	W_R	Fr
LIT-3	3.88	2.72	1.16	0.70	0.010	0.040	0.28	0.00	2.62	1.67	9.42	0.17	1.34
LIT-3	1.97	1.75	0.22	0.89	0.028	0.040	0.19	0.00	2.62	1.67	13.51	0.12	1.67
LIT-3	2.24	1.92	0.33	0.85	0.028	0.040	0.21	0.00	2.62	1.67	12.78	0.12	1.66
LIT-3	2.53	2.09	0.45	0.82	0.028	0.040	0.21	0.00	2.62	1.67	12.30	0.13	1.71
LIT-3	2.83	2.25	0.58	0.79	0.028	0.040	0.22	0.00	2.62	1.67	11.80	0.13	1.72
LIT-3	3.21	2.42	0.79	0.76	0.028	0.040	0.23	0.00	2.62	1.67	11.29	0.14	1.74
LIT-3	3.62	2.60	1.03	0.72	0.028	0.040	0.25	0.00	2.62	1.67	10.69	0.15	1.72
LIT-3	1.07	1.00	0.07	0.93	0.054	0.040	0.16	0.00	2.62	1.67	15.98	0.10	1.39
LIT-3	1.53	1.41	0.12	0.92	0.054	0.040	0.16	0.00	2.62	1.67	16.48	0.10	2.14
LIT-3	2.10	1.80	0.31	0.85	0.054	0.040	0.18	0.00	2.62	1.67	14.40	0.11	2.10
LIT-3	2.67	2.14	0.52	0.80	0.054	0.040	0.20	0.00	2.62	1.67	13.44	0.12	2.24
LIT-3	3.01	2.32	0.69	0.77	0.054	0.040	0.20	0.00	2.62	1.67	12.91	0.12	2.28
LIT-3	3.39	2.49	0.90	0.74	0.054	0.040	0.22	0.00	2.62	1.67	12.19	0.13	2.23
LIT-3	0.74	0.71	0.03	0.96	0.075	0.040	0.11	0.00	2.62	1.67	24.26	0.06	2.73
LIT-3	1.51	1.29	0.21	0.86	0.075	0.040	0.15	0.00	2.62	1.67	17.58	0.09	2.48
LIT-3	2.08	1.73	0.34	0.83	0.075	0.040	0.17	0.00	2.62	1.67	15.88	0.10	2.65
LIT-3	2.61	2.07	0.54	0.79	0.075	0.040	0.18	0.00	2.62	1.67	14.24	0.11	2.53
LIT-3	2.93	2.24	0.69	0.76	0.075	0.040	0.19	0.00	2.62	1.67	13.72	0.11	2.59
LIT-3	3.29	2.40	0.89	0.73	0.075	0.040	0.20	0.00	2.62	1.67	13.03	0.12	2.56
LIT-4	2.26	1.77	0.48	0.79	0.005	0.040	0.26	0.00	2.24	1.94	8.68	0.13	0.94
LIT-4	2.58	1.96	0.62	0.76	0.005	0.040	0.27	0.00	2.24	1.94	8.30	0.14	0.96
LIT-4	2.98	2.16	0.82	0.72	0.005	0.040	0.29	0.00	2.24	1.94	7.78	0.15	0.94
LIT-4	3.37	2.35	1.03	0.70	0.005	0.040	0.30	0.00	2.24	1.94	7.42	0.16	0.95
LIT-4	3.84	2.57	1.27	0.67	0.005	0.040	0.32	0.00	2.24	1.94	7.09	0.16	0.96
LIT-4	4.30	2.79	1.51	0.65	0.005	0.040	0.33	0.00	2.24	1.94	6.87	0.17	1.00
LIT-4	1.33	1.24	0.10	0.93	0.010	0.040	0.18	0.00	2.24	1.94	12.58	0.09	1.41
LIT-4	2.01	1.76	0.26	0.87	0.010	0.040	0.21	0.00	2.24	1.94	10.87	0.11	1.47
LIT-4	2.29	1.95	0.35	0.85	0.010	0.040	0.22	0.00	2.24	1.94	10.37	0.11	1.49
LIT-4	2.92	2.32	0.60	0.79	0.010	0.040	0.24	0.00	2.24	1.94	9.45	0.12	1.51
LIT-4	3.37	2.53	0.84	0.75	0.010	0.040	0.26	0.00	2.24	1.94	8.78	0.13	1.45
LIT-4	3.83	2.74	1.10	0.71	0.010	0.040	0.27	0.00	2.24	1.94	8.24	0.14	1.40
LIT-4	1.04	1.00	0.04	0.97	0.028	0.040	0.15	0.00	2.24	1.94	15.34	0.08	1.80
LIT-4	1.31	1.22	0.09	0.93	0.028	0.040	0.17	0.00	2.24	1.94	13.25	0.09	1.58
LIT-4	1.59	1.45	0.15	0.91	0.028	0.040	0.18	0.00	2.24	1.94	12.31	0.09	1.59
LIT-4	1.97	1.71	0.26	0.87	0.028	0.040	0.20	0.00	2.24	1.94	11.49	0.10	1.66
LIT-4	2.26	1.87	0.39	0.83	0.028	0.040	0.21	0.00	2.24	1.94	10.77	0.11	1.61
LIT-4	2.83	2.19	0.65	0.77	0.028	0.040	0.22	0.00	2.24	1.94	10.04	0.11	1.70
LIT-4	3.66	2.61	1.04	0.72	0.054	0.040	0.25	0.00	2.24	1.94	9.07	0.13	1.70
LIT-4	1.08	0.96	0.12	0.89	0.054	0.040	0.17	0.00	2.24	1.94	13.41	0.09	1.34

Continued on next page

Table 5: Literature-Derived Performance Data for Drop-Type Inlets — Continued

ID-CODE	Q_A	Q_I	Q_O	Q_R	S_0	S_x	d_a	h_b	L_I	W_I	L_R	W_R	Fr
LIT-4	1.53	1.32	0.21	0.86	0.054	0.040	0.16	0.00	2.24	1.94	13.91	0.08	2.08
LIT-4	1.89	1.57	0.32	0.83	0.054	0.040	0.17	0.00	2.24	1.94	12.95	0.09	2.14
LIT-4	2.14	1.73	0.41	0.81	0.054	0.040	0.18	0.00	2.24	1.94	12.31	0.09	2.14
LIT-4	2.70	2.07	0.63	0.77	0.054	0.040	0.20	0.00	2.24	1.94	11.26	0.10	2.15
LIT-4	2.39	2.41	-0.02	1.01	0.075	0.040	0.22	0.00	2.24	1.94	10.42	0.11	1.57
LIT-4	1.03	0.86	0.17	0.84	0.075	0.040	0.14	0.00	2.24	1.94	16.00	0.07	1.99
LIT-4	1.26	1.04	0.22	0.83	0.075	0.040	0.14	0.00	2.24	1.94	16.12	0.07	2.46
LIT-4	1.51	1.20	0.30	0.80	0.075	0.040	0.15	0.00	2.24	1.94	15.03	0.08	2.48
LIT-4	2.08	1.60	0.48	0.77	0.075	0.040	0.17	0.00	2.24	1.94	13.58	0.09	2.65
LIT-4	2.61	1.92	0.69	0.73	0.075	0.040	0.18	0.00	2.24	1.94	12.17	0.09	2.54
LIT-4	3.29	2.23	1.06	0.68	0.130	0.040	0.20	0.00	2.24	1.94	11.14	0.10	2.56
LIT-4	0.51	0.41	0.10	0.80	0.130	0.040	0.09	0.00	2.24	1.94	24.35	0.05	2.80
LIT-4	1.02	0.73	0.29	0.71	0.130	0.040	0.11	0.00	2.24	1.94	20.55	0.06	3.67
LIT-4	1.48	1.05	0.44	0.71	0.130	0.040	0.13	0.00	2.24	1.94	16.72	0.07	3.18
LIT-4	2.01	1.41	0.61	0.70	0.130	0.040	0.14	0.00	2.24	1.94	15.56	0.07	3.61
LIT-4	2.51	1.69	0.82	0.67	0.130	0.040	0.16	0.00	2.24	1.94	13.83	0.08	3.35
LIT-4	3.15	2.01	1.14	0.64	0.130	0.040	0.18	0.00	2.24	1.94	12.51	0.09	3.27
LIT-5	1.47	1.24	0.23	0.85	0.005	0.040	0.22	0.00	1.88	1.97	8.39	0.11	0.87
LIT-5	1.77	1.47	0.30	0.83	0.005	0.040	0.23	0.00	1.88	1.97	8.10	0.12	0.96
LIT-5	2.24	1.76	0.48	0.79	0.005	0.040	0.25	0.00	1.88	1.97	7.40	0.13	0.97
LIT-5	2.57	1.93	0.64	0.75	0.005	0.040	0.27	0.00	1.88	1.97	6.96	0.14	0.96
LIT-5	2.98	2.12	0.86	0.71	0.005	0.040	0.29	0.00	1.88	1.97	6.55	0.15	0.95
LIT-5	3.39	2.30	1.09	0.68	0.005	0.040	0.30	0.00	1.88	1.97	6.23	0.15	0.95
LIT-5	4.36	2.72	1.65	0.62	0.005	0.040	0.33	0.00	1.88	1.97	5.66	0.17	0.97
LIT-5	1.33	1.20	0.13	0.90	0.010	0.040	0.18	0.00	1.88	1.97	10.74	0.09	1.46
LIT-5	1.62	1.40	0.23	0.86	0.010	0.040	0.19	0.00	1.88	1.97	9.79	0.10	1.42
LIT-5	2.01	1.64	0.37	0.82	0.010	0.040	0.20	0.00	1.88	1.97	9.22	0.10	1.51
LIT-5	2.29	1.79	0.50	0.78	0.010	0.040	0.22	0.00	1.88	1.97	8.74	0.11	1.51
LIT-5	2.92	2.14	0.78	0.73	0.010	0.040	0.24	0.00	1.88	1.97	7.93	0.12	1.51
LIT-5	3.75	2.57	1.18	0.69	0.010	0.040	0.26	0.00	1.88	1.97	7.20	0.13	1.52
LIT-5	1.04	0.97	0.07	0.94	0.028	0.040	0.14	0.00	1.88	1.97	13.06	0.07	1.86
LIT-5	1.30	1.18	0.12	0.91	0.028	0.040	0.16	0.00	1.88	1.97	11.53	0.08	1.71
LIT-5	1.58	1.39	0.19	0.88	0.028	0.040	0.18	0.00	1.88	1.97	10.50	0.09	1.65
LIT-5	2.24	1.81	0.43	0.81	0.028	0.040	0.20	0.00	1.88	1.97	9.22	0.10	1.68
LIT-5	2.86	2.15	0.71	0.75	0.028	0.040	0.23	0.00	1.88	1.97	8.32	0.11	1.66
LIT-5	3.59	2.54	1.04	0.71	0.028	0.040	0.24	0.00	1.88	1.97	7.80	0.12	1.77
LIT-5	0.50	0.44	0.06	0.89	0.054	0.040	0.10	0.00	1.88	1.97	18.25	0.05	2.06
LIT-5	1.08	0.86	0.22	0.80	0.054	0.040	0.17	0.00	1.88	1.97	11.39	0.08	1.37
LIT-5	1.35	1.02	0.33	0.76	0.054	0.040	0.18	0.00	1.88	1.97	10.50	0.09	1.40

Continued on next page

Table 5: Literature-Derived Performance Data for Drop-Type Inlets — Continued

ID-CODE	Q_A	Q_I	Q_O	Q_R	S_0	S_x	d_a	h_b	L_I	W_I	L_R	W_R	Fr
LIT-5	1.63	1.22	0.42	0.75	0.054	0.040	0.19	0.00	1.88	1.97	9.89	0.10	1.46
LIT-5	2.15	1.58	0.58	0.73	0.054	0.040	0.19	0.00	1.88	1.97	10.16	0.09	2.06
LIT-5	2.71	1.80	0.91	0.66	0.054	0.040	0.20	0.00	1.88	1.97	9.31	0.10	2.08
LIT-5	3.40	2.08	1.33	0.61	0.054	0.040	0.22	0.00	1.88	1.97	8.74	0.11	2.24
LIT-5	0.51	0.43	0.09	0.83	0.075	0.040	0.09	0.00	1.88	1.97	20.22	0.05	2.73
LIT-5	1.03	0.75	0.29	0.72	0.075	0.040	0.14	0.00	1.88	1.97	13.53	0.07	2.02
LIT-5	1.51	1.07	0.44	0.71	0.075	0.040	0.15	0.00	1.88	1.97	12.62	0.08	2.48
LIT-5	2.08	1.43	0.65	0.69	0.075	0.040	0.17	0.00	1.88	1.97	11.33	0.08	2.61
LIT-5	2.61	1.67	0.95	0.64	0.075	0.040	0.18	0.00	1.88	1.97	10.22	0.09	2.54
LIT-5	3.26	1.86	1.40	0.57	0.075	0.040	0.20	0.00	1.88	1.97	9.54	0.10	2.67
LIT-5	0.52	0.35	0.17	0.68	0.130	0.040	0.13	0.00	1.88	1.97	15.04	0.06	1.32
LIT-5	1.02	0.66	0.36	0.65	0.130	0.040	0.11	0.00	1.88	1.97	16.64	0.06	3.35
LIT-5	1.49	0.93	0.55	0.63	0.130	0.040	0.14	0.00	1.88	1.97	13.82	0.07	3.07
LIT-5	2.01	1.22	0.79	0.61	0.130	0.040	0.15	0.00	1.88	1.97	12.88	0.07	3.47
LIT-5	2.53	1.47	1.06	0.58	0.130	0.040	0.17	0.00	1.88	1.97	11.33	0.08	3.17
LIT-5	3.19	1.70	1.49	0.53	0.130	0.040	0.18	0.00	1.88	1.97	10.27	0.09	3.14
LIT-6	4.10	2.79	1.31	0.68	0.005	0.040	0.33	0.00	2.83	2.46	8.63	0.13	0.94
LIT-6	4.69	3.02	1.67	0.64	0.005	0.040	0.34	0.00	2.83	2.46	8.27	0.14	0.97
LIT-6	5.41	3.23	2.18	0.60	0.005	0.040	0.37	0.00	2.83	2.46	7.73	0.15	0.94
LIT-6	6.13	3.42	2.72	0.56	0.005	0.040	0.38	0.00	2.83	2.46	7.37	0.16	0.95
LIT-6	6.98	3.60	3.38	0.52	0.005	0.040	0.40	0.00	2.83	2.46	7.06	0.16	0.97
LIT-6	7.81	3.78	4.03	0.48	0.005	0.040	0.41	0.00	2.83	2.46	6.84	0.17	1.00
LIT-6	2.43	2.07	0.35	0.85	0.010	0.040	0.23	0.00	2.83	2.46	12.52	0.09	1.41
LIT-6	3.66	2.82	0.84	0.77	0.010	0.040	0.26	0.00	2.83	2.46	10.84	0.11	1.48
LIT-6	4.17	3.06	1.11	0.73	0.010	0.040	0.27	0.00	2.83	2.46	10.33	0.11	1.50
LIT-6	5.31	3.48	1.82	0.66	0.010	0.040	0.30	0.00	2.83	2.46	9.40	0.12	1.51
LIT-6	6.12	3.68	2.44	0.60	0.010	0.040	0.32	0.00	2.83	2.46	8.73	0.13	1.44
LIT-6	6.97	3.85	3.12	0.55	0.010	0.040	0.35	0.00	2.83	2.46	8.20	0.14	1.40
LIT-6	1.89	1.71	0.18	0.90	0.028	0.040	0.19	0.00	2.83	2.46	15.30	0.08	1.81
LIT-6	2.39	2.05	0.34	0.86	0.028	0.040	0.21	0.00	2.83	2.46	13.22	0.09	1.59
LIT-6	2.90	2.38	0.52	0.82	0.028	0.040	0.23	0.00	2.83	2.46	12.25	0.09	1.59
LIT-6	3.59	2.75	0.84	0.77	0.028	0.040	0.25	0.00	2.83	2.46	11.41	0.10	1.65
LIT-6	4.11	2.95	1.16	0.72	0.028	0.040	0.26	0.00	2.83	2.46	10.72	0.11	1.62
LIT-6	5.15	3.31	1.84	0.64	0.028	0.040	0.28	0.00	2.83	2.46	9.96	0.12	1.69
LIT-6	6.65	3.72	2.92	0.56	0.028	0.040	0.31	0.00	2.83	2.46	9.01	0.13	1.70
LIT-6	1.97	1.63	0.34	0.83	0.054	0.040	0.21	0.00	2.83	2.46	13.35	0.09	1.34
LIT-6	2.79	2.19	0.60	0.79	0.054	0.040	0.21	0.00	2.83	2.46	13.80	0.08	2.06
LIT-6	3.43	2.53	0.90	0.74	0.054	0.040	0.22	0.00	2.83	2.46	12.92	0.09	2.16
LIT-6	3.89	2.75	1.14	0.71	0.054	0.040	0.23	0.00	2.83	2.46	12.20	0.09	2.12

Continued on next page

Table 5: Literature-Derived Performance Data for Drop-Type Inlets — Continued

ID-CODE	Q_A	Q_I	Q_O	Q_R	S_0	S_x	d_a	h_b	L_I	W_I	L_R	W_R	Fr
LIT-6	4.90	3.16	1.74	0.65	0.054	0.040	0.25	0.00	2.83	2.46	11.19	0.10	2.15
LIT-6	6.16	3.50	2.66	0.57	0.054	0.040	0.27	0.00	2.83	2.46	10.37	0.11	2.23
LIT-6	1.88	1.47	0.41	0.78	0.075	0.040	0.18	0.00	2.83	2.46	15.90	0.07	1.98
LIT-6	2.29	1.75	0.54	0.76	0.075	0.040	0.18	0.00	2.83	2.46	15.99	0.07	2.45
LIT-6	2.74	1.99	0.75	0.73	0.075	0.040	0.19	0.00	2.83	2.46	14.97	0.08	2.49
LIT-6	3.77	2.55	1.22	0.68	0.075	0.040	0.21	0.00	2.83	2.46	13.48	0.09	2.63
LIT-6	4.75	2.95	1.80	0.62	0.075	0.040	0.23	0.00	2.83	2.46	12.15	0.09	2.55
LIT-6	5.98	3.27	2.72	0.55	0.075	0.040	0.26	0.00	2.83	2.46	11.05	0.10	2.54
LIT-6	0.93	0.72	0.21	0.77	0.130	0.040	0.12	0.00	2.83	2.46	24.40	0.05	2.85
LIT-6	1.85	1.24	0.62	0.67	0.130	0.040	0.14	0.00	2.83	2.46	20.51	0.06	3.69
LIT-6	2.70	1.74	0.96	0.64	0.130	0.040	0.17	0.00	2.83	2.46	16.55	0.07	3.14
LIT-6	3.66	2.26	1.41	0.62	0.130	0.040	0.18	0.00	2.83	2.46	15.46	0.07	3.60
LIT-6	4.56	2.62	1.95	0.57	0.130	0.040	0.21	0.00	2.83	2.46	13.74	0.08	3.34
LIT-6	5.72	2.97	2.75	0.52	0.130	0.040	0.23	0.00	2.83	2.46	12.41	0.09	3.25
LIT-7	3.20	2.39	0.81	0.75	0.005	0.040	0.29	0.00	2.83	2.46	9.66	0.12	0.97
LIT-7	4.08	2.76	1.32	0.68	0.005	0.040	0.33	0.00	2.83	2.46	8.71	0.13	0.96
LIT-7	4.66	2.96	1.70	0.63	0.005	0.040	0.34	0.00	2.83	2.46	8.37	0.14	0.99
LIT-7	6.12	3.27	2.85	0.53	0.005	0.040	0.38	0.00	2.83	2.46	7.39	0.16	0.95
LIT-7	7.90	3.52	4.38	0.45	0.005	0.040	0.42	0.00	2.83	2.46	6.72	0.17	0.97
LIT-7	0.91	0.88	0.04	0.96	0.010	0.040	0.15	0.00	2.83	2.46	19.12	0.06	1.52
LIT-7	1.92	1.68	0.24	0.87	0.010	0.040	0.20	0.00	2.83	2.46	14.15	0.08	1.51
LIT-7	2.95	2.23	0.72	0.76	0.010	0.040	0.25	0.00	2.83	2.46	11.55	0.10	1.40
LIT-7	4.19	2.78	1.42	0.66	0.010	0.040	0.28	0.00	2.83	2.46	10.29	0.11	1.49
LIT-7	5.31	3.06	2.26	0.58	0.010	0.040	0.30	0.00	2.83	2.46	9.34	0.12	1.48
LIT-7	6.90	3.33	3.57	0.48	0.010	0.040	0.34	0.00	2.83	2.46	8.35	0.14	1.45
LIT-7	0.93	0.84	0.08	0.91	0.028	0.040	0.14	0.00	2.83	2.46	20.07	0.06	1.75
LIT-7	1.89	1.55	0.34	0.82	0.028	0.040	0.18	0.00	2.83	2.46	15.46	0.07	1.86
LIT-7	2.87	2.08	0.79	0.73	0.028	0.040	0.23	0.00	2.83	2.46	12.52	0.09	1.67
LIT-7	4.07	2.56	1.51	0.63	0.028	0.040	0.26	0.00	2.83	2.46	10.93	0.11	1.68
LIT-7	5.18	2.84	2.34	0.55	0.028	0.040	0.29	0.00	2.83	2.46	9.90	0.12	1.67
LIT-7	6.53	3.06	3.47	0.47	0.028	0.040	0.31	0.00	2.83	2.46	9.22	0.12	1.76
LIT-7	0.95	0.81	0.14	0.85	0.054	0.040	0.13	0.00	2.83	2.46	21.12	0.05	2.04
LIT-7	1.95	1.31	0.64	0.67	0.054	0.040	0.21	0.00	2.83	2.46	13.67	0.08	1.41
LIT-7	2.79	1.85	0.94	0.66	0.054	0.040	0.20	0.00	2.83	2.46	13.87	0.08	2.09
LIT-7	3.47	2.08	1.39	0.60	0.054	0.040	0.23	0.00	2.83	2.46	12.47	0.09	1.99
LIT-7	3.93	2.20	1.73	0.56	0.054	0.040	0.24	0.00	2.83	2.46	11.94	0.10	2.03
LIT-7	4.96	2.38	2.58	0.48	0.054	0.040	0.26	0.00	2.83	2.46	10.84	0.11	2.01
LIT-7	6.16	2.60	3.56	0.42	0.054	0.040	0.27	0.00	2.83	2.46	10.33	0.11	2.21
LIT-7	1.35	0.99	0.37	0.73	0.075	0.040	0.14	0.00	2.83	2.46	20.51	0.06	2.69

Continued on next page

Table 5: Literature-Derived Performance Data for Drop-Type Inlets — Continued

ID-CODE	Q_A	Q_I	Q_O	Q_R	S_0	S_x	d_a	h_b	L_I	W_I	L_R	W_R	Fr
LIT-7	1.88	1.16	0.72	0.62	0.075	0.040	0.18	0.00	2.83	2.46	15.55	0.07	1.88
LIT-7	2.74	1.47	1.27	0.54	0.075	0.040	0.19	0.00	2.83	2.46	14.97	0.08	2.49
LIT-7	3.79	1.94	1.85	0.51	0.075	0.040	0.21	0.00	2.83	2.46	13.35	0.09	2.58
LIT-7	4.75	2.20	2.55	0.46	0.075	0.040	0.23	0.00	2.83	2.46	12.09	0.10	2.53
LIT-7	5.94	2.36	3.58	0.40	0.075	0.040	0.25	0.00	2.83	2.46	11.23	0.10	2.63
LIT-8	1.76	1.47	0.29	0.84	0.005	0.040	0.23	0.00	2.24	1.94	9.70	0.12	0.97
LIT-8	2.24	1.75	0.50	0.78	0.005	0.040	0.26	0.00	2.24	1.94	8.75	0.13	0.95
LIT-8	2.56	1.92	0.65	0.75	0.005	0.040	0.27	0.00	2.24	1.94	8.42	0.14	0.99
LIT-8	3.37	2.24	1.12	0.67	0.005	0.040	0.30	0.00	2.24	1.94	7.42	0.16	0.95
LIT-8	4.34	2.60	1.74	0.60	0.005	0.040	0.33	0.00	2.24	1.94	6.77	0.17	0.97
LIT-8	0.50	0.50	0.00	0.99	0.010	0.040	0.12	0.00	2.24	1.94	19.15	0.06	1.51
LIT-8	1.06	0.98	0.07	0.93	0.010	0.040	0.16	0.00	2.24	1.94	14.18	0.08	1.50
LIT-8	1.62	1.36	0.27	0.84	0.010	0.040	0.19	0.00	2.24	1.94	11.61	0.10	1.40
LIT-8	2.31	1.77	0.54	0.77	0.010	0.040	0.22	0.00	2.24	1.94	10.37	0.11	1.50
LIT-8	2.92	2.03	0.89	0.70	0.010	0.040	0.24	0.00	2.24	1.94	9.37	0.12	1.48
LIT-8	3.79	2.36	1.43	0.62	0.010	0.040	0.27	0.00	2.24	1.94	8.39	0.14	1.45
LIT-8	0.51	0.48	0.03	0.94	0.028	0.040	0.11	0.00	2.24	1.94	20.18	0.06	1.75
LIT-8	1.04	0.91	0.13	0.88	0.028	0.040	0.14	0.00	2.24	1.94	15.56	0.07	1.86
LIT-8	1.58	1.26	0.32	0.80	0.028	0.040	0.18	0.00	2.24	1.94	12.58	0.09	1.67
LIT-8	2.24	1.62	0.62	0.72	0.028	0.040	0.20	0.00	2.24	1.94	10.98	0.11	1.68
LIT-8	2.85	1.88	0.97	0.66	0.028	0.040	0.23	0.00	2.24	1.94	9.96	0.12	1.67
LIT-8	3.59	2.14	1.46	0.59	0.028	0.040	0.24	0.00	2.24	1.94	9.26	0.12	1.76
LIT-8	0.52	0.46	0.06	0.88	0.054	0.040	0.11	0.00	2.24	1.94	21.33	0.05	2.06
LIT-8	1.07	0.77	0.30	0.72	0.054	0.040	0.16	0.00	2.24	1.94	13.74	0.08	1.41
LIT-8	1.53	1.12	0.41	0.73	0.054	0.040	0.16	0.00	2.24	1.94	14.00	0.08	2.11
LIT-8	1.91	1.29	0.62	0.68	0.054	0.040	0.18	0.00	2.24	1.94	12.51	0.09	1.99
LIT-8	2.16	1.39	0.77	0.64	0.054	0.040	0.19	0.00	2.24	1.94	11.98	0.10	2.02
LIT-8	2.73	1.56	1.17	0.57	0.054	0.040	0.21	0.00	2.24	1.94	10.93	0.11	2.02
LIT-8	3.39	1.79	1.60	0.53	0.054	0.040	0.22	0.00	2.24	1.94	10.42	0.11	2.23
LIT-8	0.74	0.57	0.18	0.76	0.075	0.040	0.11	0.00	2.24	1.94	20.55	0.06	2.67
LIT-8	1.04	0.68	0.36	0.66	0.075	0.040	0.14	0.00	2.24	1.94	15.66	0.07	1.89
LIT-8	1.51	0.89	0.62	0.59	0.075	0.040	0.15	0.00	2.24	1.94	15.03	0.08	2.48
LIT-8	2.08	1.21	0.87	0.58	0.075	0.040	0.17	0.00	2.24	1.94	13.41	0.09	2.58
LIT-8	2.61	1.43	1.18	0.55	0.075	0.040	0.18	0.00	2.24	1.94	12.17	0.09	2.54
LIT-8	3.27	1.61	1.66	0.49	0.075	0.040	0.20	0.00	2.24	1.94	11.31	0.10	2.64
LIT-9	2.24	2.24	0.01	1.00	0.005	0.063	0.32	0.00	3.00	4.00	9.52	0.08	0.89
LIT-9	2.62	2.61	0.01	1.00	0.005	0.063	0.33	0.00	3.00	4.00	8.98	0.08	0.89
LIT-9	3.93	3.73	0.20	0.95	0.005	0.063	0.39	0.00	3.00	4.00	7.72	0.10	0.92
LIT-9	5.36	4.82	0.55	0.90	0.005	0.063	0.44	0.00	3.00	4.00	6.86	0.11	0.94

Continued on next page

Table 5: Literature-Derived Performance Data for Drop-Type Inlets — Continued

ID-CODE	Q_A	Q_I	Q_O	Q_R	S_0	S_x	d_a	h_b	L_I	W_I	L_R	W_R	Fr
LIT-9	2.28	2.28	0.01	1.00	0.010	0.063	0.28	0.00	3.00	4.00	10.77	0.07	1.23
LIT-9	3.02	2.99	0.03	0.99	0.010	0.063	0.31	0.00	3.00	4.00	9.69	0.08	1.25
LIT-9	4.09	3.93	0.16	0.96	0.010	0.063	0.35	0.00	3.00	4.00	8.65	0.09	1.27
LIT-9	4.75	4.46	0.29	0.94	0.010	0.063	0.37	0.00	3.00	4.00	8.18	0.09	1.28
LIT-9	5.49	5.01	0.48	0.91	0.010	0.063	0.39	0.00	3.00	4.00	7.75	0.10	1.30
LIT-9	2.53	2.53	0.00	1.00	0.020	0.063	0.25	0.00	3.00	4.00	11.80	0.06	1.71
LIT-9	3.26	3.24	0.02	0.99	0.020	0.063	0.28	0.00	3.00	4.00	10.73	0.07	1.74
LIT-9	4.86	4.63	0.23	0.95	0.020	0.063	0.32	0.00	3.00	4.00	9.23	0.08	1.78
LIT-9	5.49	5.12	0.37	0.93	0.020	0.063	0.34	0.00	3.00	4.00	8.82	0.08	1.79
LIT-9	2.83	2.83	0.00	1.00	0.040	0.063	0.23	0.00	3.00	4.00	12.89	0.06	2.38
LIT-9	3.13	3.12	0.01	1.00	0.040	0.063	0.24	0.00	3.00	4.00	12.41	0.06	2.40
LIT-9	3.35	3.34	0.01	1.00	0.040	0.063	0.25	0.00	3.00	4.00	12.09	0.06	2.41
LIT-9	3.82	3.78	0.04	0.99	0.040	0.063	0.26	0.00	3.00	4.00	11.51	0.07	2.43
LIT-9	4.38	4.28	0.10	0.98	0.040	0.063	0.27	0.00	3.00	4.00	10.93	0.07	2.45
LIT-9	5.20	4.91	0.29	0.94	0.040	0.063	0.29	0.00	3.00	4.00	10.25	0.07	2.47
LIT-9	3.52	3.51	0.01	1.00	0.060	0.063	0.23	0.00	3.00	4.00	12.81	0.06	2.92
LIT-9	4.03	4.02	0.02	1.00	0.060	0.063	0.25	0.00	3.00	4.00	12.17	0.06	2.94
LIT-9	4.87	4.75	0.13	0.97	0.060	0.063	0.26	0.00	3.00	4.00	11.33	0.07	2.98
LIT-9	5.38	5.19	0.19	0.96	0.060	0.063	0.27	0.00	3.00	4.00	10.92	0.07	3.00
LIT-9	3.48	3.48	0.00	1.00	0.090	0.063	0.22	0.00	3.00	4.00	13.87	0.05	3.53
LIT-9	4.46	4.40	0.07	0.99	0.090	0.063	0.24	0.00	3.00	4.00	12.64	0.06	3.58
LIT-9	5.34	5.09	0.25	0.95	0.090	0.063	0.25	0.00	3.00	4.00	11.82	0.06	3.62
LIT-9	3.33	3.32	0.01	1.00	0.130	0.063	0.20	0.00	3.00	4.00	15.12	0.05	4.18
LIT-9	4.45	4.35	0.10	0.98	0.130	0.063	0.22	0.00	3.00	4.00	13.56	0.06	4.26
LIT-9	5.44	5.16	0.27	0.95	0.130	0.063	0.24	0.00	3.00	4.00	12.58	0.06	4.31
LIT-9	1.17	1.17	0.00	1.00	0.005	0.042	0.21	0.00	3.00	4.00	14.12	0.05	0.83
LIT-9	1.73	1.70	0.03	0.99	0.005	0.042	0.25	0.00	3.00	4.00	12.18	0.06	0.85
LIT-9	2.22	2.12	0.11	0.95	0.005	0.042	0.27	0.00	3.00	4.00	11.08	0.07	0.86
LIT-9	1.25	1.25	0.00	1.00	0.010	0.042	0.19	0.00	3.00	4.00	15.66	0.05	1.15
LIT-9	1.73	1.70	0.02	0.99	0.010	0.042	0.22	0.00	3.00	4.00	13.87	0.05	1.18
LIT-9	2.23	2.14	0.09	0.96	0.010	0.042	0.24	0.00	3.00	4.00	12.61	0.06	1.20
LIT-9	2.91	2.66	0.25	0.91	0.010	0.042	0.26	0.00	3.00	4.00	11.41	0.07	1.22
LIT-9	3.21	2.88	0.33	0.90	0.010	0.042	0.27	0.00	3.00	4.00	11.00	0.07	1.22
LIT-9	1.48	1.48	0.00	1.00	0.020	0.042	0.18	0.00	3.00	4.00	16.75	0.04	1.61
LIT-9	1.84	1.82	0.02	0.99	0.020	0.042	0.19	0.00	3.00	4.00	15.44	0.05	1.63
LIT-9	2.75	2.59	0.16	0.94	0.020	0.042	0.23	0.00	3.00	4.00	13.26	0.06	1.68
LIT-9	3.70	3.30	0.39	0.89	0.020	0.042	0.25	0.00	3.00	4.00	11.88	0.06	1.71
LIT-9	4.82	4.09	0.73	0.85	0.020	0.042	0.28	0.00	3.00	4.00	10.75	0.07	1.74
LIT-9	1.60	1.59	0.00	1.00	0.040	0.042	0.16	0.00	3.00	4.00	18.52	0.04	2.24

Continued on next page

Table 5: Literature-Derived Performance Data for Drop-Type Inlets — Continued

ID-CODE	Q_A	Q_I	Q_O	Q_R	S_0	S_x	d_a	h_b	L_I	W_I	L_R	W_R	Fr
LIT-9	1.85	1.84	0.01	1.00	0.040	0.042	0.17	0.00	3.00	4.00	17.55	0.04	2.26
LIT-9	2.87	2.74	0.13	0.96	0.040	0.042	0.20	0.00	3.00	4.00	14.87	0.05	2.33
LIT-9	4.06	3.68	0.38	0.91	0.040	0.042	0.23	0.00	3.00	4.00	13.06	0.06	2.38
LIT-9	5.43	4.62	0.81	0.85	0.040	0.042	0.26	0.00	3.00	4.00	11.71	0.06	2.42
LIT-9	1.58	1.58	0.00	1.00	0.060	0.042	0.15	0.00	3.00	4.00	20.05	0.04	2.71
LIT-9	1.83	1.82	0.00	1.00	0.060	0.042	0.16	0.00	3.00	4.00	19.01	0.04	2.73
LIT-9	2.75	2.66	0.08	0.97	0.060	0.042	0.18	0.00	3.00	4.00	16.32	0.05	2.80
LIT-9	4.02	3.69	0.32	0.92	0.060	0.042	0.21	0.00	3.00	4.00	14.15	0.05	2.87
LIT-9	5.38	4.67	0.71	0.87	0.060	0.042	0.24	0.00	3.00	4.00	12.68	0.06	2.92
LIT-9	1.83	1.83	0.00	1.00	0.090	0.042	0.15	0.00	3.00	4.00	20.49	0.04	3.31
LIT-9	2.70	2.65	0.05	0.98	0.090	0.042	0.17	0.00	3.00	4.00	17.72	0.04	3.39
LIT-9	3.84	3.63	0.22	0.94	0.090	0.042	0.19	0.00	3.00	4.00	15.52	0.05	3.46
LIT-9	5.31	4.81	0.49	0.91	0.090	0.042	0.22	0.00	3.00	4.00	13.75	0.05	3.53
LIT-9	1.88	1.88	0.00	1.00	0.130	0.042	0.14	0.00	3.00	4.00	21.75	0.03	3.93
LIT-9	2.21	2.20	0.02	0.99	0.130	0.042	0.15	0.00	3.00	4.00	20.45	0.04	3.97
LIT-9	3.93	3.73	0.20	0.95	0.130	0.042	0.18	0.00	3.00	4.00	16.49	0.05	4.12
LIT-9	5.20	4.75	0.45	0.91	0.130	0.042	0.20	0.00	3.00	4.00	14.84	0.05	4.19
LIT-9	0.51	0.51	0.01	0.98	0.005	0.021	0.12	0.00	3.00	4.00	25.00	0.03	0.76
LIT-9	0.56	0.55	0.01	0.99	0.005	0.021	0.12	0.00	3.00	4.00	24.18	0.03	0.76
LIT-9	0.76	0.73	0.03	0.96	0.005	0.021	0.14	0.00	3.00	4.00	21.61	0.03	0.77
LIT-9	1.06	0.96	0.10	0.90	0.005	0.021	0.16	0.00	3.00	4.00	19.03	0.04	0.79
LIT-9	0.47	0.47	0.00	0.99	0.010	0.021	0.10	0.00	3.00	4.00	29.37	0.03	1.04
LIT-9	0.58	0.57	0.01	0.99	0.010	0.021	0.11	0.00	3.00	4.00	27.19	0.03	1.05
LIT-9	0.63	0.62	0.01	0.98	0.010	0.021	0.11	0.00	3.00	4.00	26.36	0.03	1.06
LIT-9	0.77	0.74	0.03	0.96	0.010	0.021	0.12	0.00	3.00	4.00	24.44	0.03	1.07
LIT-9	0.93	0.88	0.05	0.94	0.010	0.021	0.13	0.00	3.00	4.00	22.75	0.03	1.08
LIT-9	0.44	0.44	0.00	1.00	0.020	0.021	0.09	0.00	3.00	4.00	34.22	0.02	1.43
LIT-9	0.62	0.62	0.01	0.99	0.020	0.021	0.10	0.00	3.00	4.00	30.14	0.02	1.46
LIT-9	0.80	0.78	0.02	0.97	0.020	0.021	0.11	0.00	3.00	4.00	27.47	0.03	1.49
LIT-9	1.15	1.05	0.10	0.91	0.020	0.021	0.13	0.00	3.00	4.00	23.94	0.03	1.52
LIT-9	1.64	1.42	0.22	0.86	0.020	0.021	0.14	0.00	3.00	4.00	20.97	0.04	1.55
LIT-9	0.55	0.55	0.00	1.00	0.040	0.021	0.08	0.00	3.00	4.00	36.07	0.02	2.01
LIT-9	0.67	0.66	0.01	0.99	0.040	0.021	0.09	0.00	3.00	4.00	33.36	0.02	2.03
LIT-9	0.81	0.79	0.02	0.97	0.040	0.021	0.10	0.00	3.00	4.00	31.04	0.02	2.06
LIT-9	1.00	0.96	0.04	0.96	0.040	0.021	0.10	0.00	3.00	4.00	28.70	0.03	2.08
LIT-9	1.32	1.19	0.13	0.90	0.040	0.021	0.12	0.00	3.00	4.00	25.91	0.03	2.12
LIT-9	1.43	1.27	0.16	0.89	0.040	0.021	0.12	0.00	3.00	4.00	25.13	0.03	2.13
LIT-9	2.35	1.90	0.45	0.81	0.040	0.021	0.14	0.00	3.00	4.00	20.87	0.04	2.20
LIT-9	0.72	0.71	0.01	0.98	0.060	0.021	0.09	0.00	3.00	4.00	35.04	0.02	2.47

Continued on next page

Table 5: Literature-Derived Performance Data for Drop-Type Inlets — Continued

ID-CODE	Q_A	Q_I	Q_O	Q_R	S_0	S_x	d_a	h_b	L_I	W_I	L_R	W_R	Fr
LIT-9	1.16	1.09	0.07	0.94	0.060	0.021	0.10	0.00	3.00	4.00	29.34	0.03	2.54
LIT-9	1.81	1.57	0.24	0.87	0.060	0.021	0.12	0.00	3.00	4.00	24.85	0.03	2.61
LIT-9	2.90	2.33	0.58	0.80	0.060	0.021	0.14	0.00	3.00	4.00	20.79	0.04	2.69
LIT-9	0.73	0.72	0.01	0.99	0.090	0.021	0.08	0.00	3.00	4.00	37.71	0.02	2.99
LIT-9	1.17	1.10	0.06	0.95	0.090	0.021	0.09	0.00	3.00	4.00	31.58	0.02	3.08
LIT-9	1.33	1.24	0.10	0.93	0.090	0.021	0.10	0.00	3.00	4.00	30.05	0.02	3.10
LIT-9	2.02	1.75	0.27	0.87	0.090	0.021	0.12	0.00	3.00	4.00	25.72	0.03	3.18
LIT-9	3.10	2.47	0.63	0.80	0.090	0.021	0.14	0.00	3.00	4.00	21.89	0.03	3.27
LIT-9	0.77	0.75	0.01	0.98	0.130	0.021	0.08	0.00	3.00	4.00	39.58	0.02	3.56
LIT-9	1.27	1.20	0.07	0.94	0.130	0.021	0.09	0.00	3.00	4.00	32.75	0.02	3.68
LIT-9	1.96	1.72	0.24	0.88	0.130	0.021	0.11	0.00	3.00	4.00	27.85	0.03	3.78
LIT-9	3.10	2.53	0.57	0.81	0.130	0.021	0.13	0.00	3.00	4.00	23.46	0.03	3.89
LIT-9	1.38	1.38	0.00	1.00	0.001	0.063	0.40	0.00	3.00	2.00	7.41	0.20	0.29
LIT-9	1.98	1.92	0.06	0.97	0.001	0.063	0.46	0.00	3.00	2.00	6.48	0.23	0.30
LIT-9	3.26	2.88	0.38	0.88	0.001	0.063	0.56	0.00	3.00	2.00	5.37	0.28	0.31
LIT-9	4.13	3.44	0.69	0.83	0.001	0.063	0.61	0.00	3.00	2.00	4.92	0.31	0.31
LIT-9	5.24	4.00	1.24	0.76	0.001	0.063	0.67	0.00	3.00	2.00	4.49	0.33	0.32
LIT-9	1.40	1.39	0.00	1.00	0.010	0.063	0.23	0.00	3.00	2.00	12.95	0.12	1.19
LIT-9	2.19	2.15	0.04	0.98	0.010	0.063	0.27	0.00	3.00	2.00	10.93	0.14	1.22
LIT-9	3.15	2.87	0.28	0.91	0.010	0.063	0.31	0.00	3.00	2.00	9.54	0.16	1.25
LIT-9	4.35	3.70	0.65	0.85	0.010	0.063	0.35	0.00	3.00	2.00	8.45	0.18	1.28
LIT-9	5.58	4.41	1.16	0.79	0.010	0.063	0.39	0.00	3.00	2.00	7.70	0.19	1.30
LIT-9	1.77	1.77	0.01	1.00	0.020	0.063	0.22	0.00	3.00	2.00	13.48	0.11	1.67
LIT-9	2.38	2.35	0.03	0.99	0.020	0.063	0.25	0.00	3.00	2.00	12.06	0.12	1.70
LIT-9	3.30	3.11	0.20	0.94	0.020	0.063	0.28	0.00	3.00	2.00	10.68	0.14	1.74
LIT-9	4.25	3.79	0.46	0.89	0.020	0.063	0.31	0.00	3.00	2.00	9.71	0.15	1.77
LIT-9	5.56	4.61	0.96	0.83	0.020	0.063	0.34	0.00	3.00	2.00	8.78	0.17	1.80
LIT-9	2.23	2.22	0.01	1.00	0.040	0.063	0.21	0.00	3.00	2.00	14.08	0.11	2.35
LIT-9	3.22	3.14	0.08	0.98	0.040	0.063	0.24	0.00	3.00	2.00	12.28	0.12	2.40
LIT-9	4.66	4.21	0.45	0.90	0.040	0.063	0.28	0.00	3.00	2.00	10.68	0.14	2.46
LIT-9	5.49	4.70	0.79	0.86	0.040	0.063	0.30	0.00	3.00	2.00	10.04	0.15	2.48
LIT-9	2.41	2.40	0.01	0.99	0.060	0.063	0.20	0.00	3.00	2.00	14.76	0.10	2.85
LIT-9	3.03	2.91	0.13	0.96	0.060	0.063	0.22	0.00	3.00	2.00	13.54	0.11	2.89
LIT-9	3.95	3.52	0.43	0.89	0.060	0.063	0.24	0.00	3.00	2.00	12.27	0.12	2.94
LIT-9	5.45	4.18	1.27	0.77	0.060	0.063	0.28	0.00	3.00	2.00	10.87	0.14	3.00
LIT-9	1.16	1.14	0.01	0.99	0.090	0.063	0.14	0.00	3.00	2.00	20.98	0.07	3.29
LIT-9	1.98	1.79	0.19	0.90	0.090	0.063	0.18	0.00	3.00	2.00	17.14	0.09	3.41
LIT-9	2.72	2.24	0.48	0.82	0.090	0.063	0.20	0.00	3.00	2.00	15.22	0.10	3.47
LIT-9	3.41	2.63	0.78	0.77	0.090	0.063	0.21	0.00	3.00	2.00	13.98	0.11	3.52

Continued on next page

Table 5: Literature-Derived Performance Data for Drop-Type Inlets — Continued

ID-CODE	Q_A	Q_I	Q_O	Q_R	S_0	S_x	d_a	h_b	L_I	W_I	L_R	W_R	Fr
LIT-9	5.27	3.39	1.89	0.64	0.090	0.063	0.25	0.00	3.00	2.00	11.88	0.13	3.62
LIT-9	1.46	1.45	0.01	0.99	0.130	0.063	0.15	0.00	3.00	2.00	20.57	0.07	3.97
LIT-9	1.98	1.90	0.07	0.96	0.130	0.063	0.16	0.00	3.00	2.00	18.38	0.08	4.05
LIT-9	2.97	2.62	0.35	0.88	0.130	0.063	0.19	0.00	3.00	2.00	15.78	0.10	4.15
LIT-9	4.04	3.25	0.79	0.80	0.130	0.063	0.21	0.00	3.00	2.00	14.06	0.11	4.23
LIT-9	5.35	3.72	1.63	0.70	0.130	0.063	0.24	0.00	3.00	2.00	12.65	0.12	4.31
LIT-9	0.72	0.72	0.00	1.00	0.005	0.042	0.18	0.00	3.00	2.00	16.93	0.09	0.80
LIT-9	1.06	1.05	0.01	0.99	0.005	0.042	0.20	0.00	3.00	2.00	14.64	0.10	0.82
LIT-9	1.74	1.61	0.14	0.92	0.005	0.042	0.25	0.00	3.00	2.00	12.15	0.12	0.85
LIT-9	2.63	2.25	0.37	0.86	0.005	0.042	0.29	0.00	3.00	2.00	10.41	0.14	0.87
LIT-9	0.77	0.77	0.00	1.00	0.010	0.042	0.16	0.00	3.00	2.00	18.79	0.08	1.12
LIT-9	1.07	1.06	0.01	0.99	0.010	0.042	0.18	0.00	3.00	2.00	16.58	0.09	1.14
LIT-9	1.21	1.19	0.02	0.98	0.010	0.042	0.19	0.00	3.00	2.00	15.84	0.09	1.15
LIT-9	1.67	1.59	0.08	0.95	0.010	0.042	0.21	0.00	3.00	2.00	14.04	0.11	1.17
LIT-9	2.50	2.21	0.29	0.88	0.010	0.042	0.25	0.00	3.00	2.00	12.08	0.12	1.20
LIT-9	3.51	2.91	0.60	0.83	0.010	0.042	0.28	0.00	3.00	2.00	10.63	0.14	1.23
LIT-9	0.95	0.94	0.00	1.00	0.020	0.042	0.15	0.00	3.00	2.00	19.81	0.08	1.57
LIT-9	1.60	1.56	0.04	0.98	0.020	0.042	0.18	0.00	3.00	2.00	16.25	0.09	1.62
LIT-9	2.55	2.30	0.25	0.90	0.020	0.042	0.22	0.00	3.00	2.00	13.66	0.11	1.67
LIT-9	3.53	3.02	0.52	0.85	0.020	0.042	0.25	0.00	3.00	2.00	12.08	0.12	1.70
LIT-9	5.15	4.12	1.03	0.80	0.020	0.042	0.29	0.00	3.00	2.00	10.49	0.14	1.74
LIT-9	1.01	1.01	0.00	1.00	0.040	0.042	0.14	0.00	3.00	2.00	21.99	0.07	2.18
LIT-9	1.29	1.27	0.02	0.98	0.040	0.042	0.15	0.00	3.00	2.00	20.08	0.07	2.21
LIT-9	2.72	2.38	0.34	0.88	0.040	0.042	0.20	0.00	3.00	2.00	15.17	0.10	2.32
LIT-9	3.41	2.86	0.55	0.84	0.040	0.042	0.22	0.00	3.00	2.00	13.94	0.11	2.35
LIT-9	4.41	3.51	0.90	0.80	0.040	0.042	0.24	0.00	3.00	2.00	12.66	0.12	2.39
LIT-9	5.27	3.95	1.32	0.75	0.040	0.042	0.25	0.00	3.00	2.00	11.84	0.13	2.42
LIT-9	1.33	1.32	0.00	1.00	0.060	0.042	0.14	0.00	3.00	2.00	21.42	0.07	2.68
LIT-9	2.48	2.40	0.08	0.97	0.060	0.042	0.18	0.00	3.00	2.00	16.95	0.09	2.79
LIT-9	3.85	3.41	0.44	0.89	0.060	0.042	0.21	0.00	3.00	2.00	14.37	0.10	2.86
LIT-9	5.44	4.31	1.13	0.79	0.060	0.042	0.24	0.00	3.00	2.00	12.62	0.12	2.93
LIT-9	1.39	1.39	0.00	1.00	0.090	0.042	0.13	0.00	3.00	2.00	22.73	0.07	3.25
LIT-9	1.73	1.71	0.02	0.99	0.090	0.042	0.14	0.00	3.00	2.00	20.95	0.07	3.29
LIT-9	2.62	2.43	0.19	0.93	0.090	0.042	0.17	0.00	3.00	2.00	17.92	0.08	3.38
LIT-9	3.88	3.07	0.82	0.79	0.090	0.042	0.19	0.00	3.00	2.00	15.46	0.10	3.46
LIT-9	5.36	3.49	1.88	0.65	0.090	0.042	0.22	0.00	3.00	2.00	13.70	0.11	3.54
LIT-9	1.43	1.43	0.00	1.00	0.130	0.042	0.12	0.00	3.00	2.00	24.09	0.06	3.87
LIT-9	1.98	1.93	0.05	0.97	0.130	0.042	0.14	0.00	3.00	2.00	21.30	0.07	3.95
LIT-9	2.55	2.41	0.14	0.95	0.130	0.042	0.15	0.00	3.00	2.00	19.40	0.08	4.01

Continued on next page

Table 5: Literature-Derived Performance Data for Drop-Type Inlets — Continued

ID-CODE	Q_A	Q_I	Q_O	Q_R	S_0	S_x	d_a	h_b	L_I	W_I	L_R	W_R	Fr
LIT-9	4.09	3.58	0.51	0.88	0.130	0.042	0.18	0.00	3.00	2.00	16.24	0.09	4.13
LIT-9	5.50	4.42	1.08	0.80	0.130	0.042	0.21	0.00	3.00	2.00	14.54	0.10	4.21
LIT-9	0.24	0.24	0.00	1.00	0.005	0.021	0.09	0.00	3.00	2.00	33.12	0.05	0.72
LIT-9	0.42	0.41	0.01	0.98	0.005	0.021	0.11	0.00	3.00	2.00	26.90	0.06	0.74
LIT-9	0.61	0.58	0.03	0.95	0.005	0.021	0.13	0.00	3.00	2.00	23.42	0.06	0.76
LIT-9	0.91	0.80	0.11	0.88	0.005	0.021	0.15	0.00	3.00	2.00	20.14	0.07	0.78
LIT-9	0.28	0.28	0.00	1.00	0.010	0.021	0.08	0.00	3.00	2.00	35.97	0.04	1.00
LIT-9	0.52	0.50	0.02	0.96	0.010	0.021	0.11	0.00	3.00	2.00	28.38	0.05	1.05
LIT-9	0.86	0.77	0.09	0.89	0.010	0.021	0.13	0.00	3.00	2.00	23.45	0.06	1.08
LIT-9	1.19	1.01	0.19	0.84	0.010	0.021	0.14	0.00	3.00	2.00	20.74	0.07	1.10
LIT-9	0.32	0.32	0.00	1.00	0.020	0.021	0.08	0.00	3.00	2.00	38.69	0.04	1.40
LIT-9	0.53	0.52	0.01	0.98	0.020	0.021	0.09	0.00	3.00	2.00	32.04	0.05	1.45
LIT-9	0.91	0.83	0.09	0.91	0.020	0.021	0.11	0.00	3.00	2.00	26.12	0.06	1.50
LIT-9	1.21	1.03	0.17	0.86	0.020	0.021	0.13	0.00	3.00	2.00	23.53	0.06	1.52
LIT-9	1.72	1.35	0.37	0.79	0.020	0.021	0.15	0.00	3.00	2.00	20.59	0.07	1.56
LIT-9	0.41	0.41	0.00	1.00	0.040	0.021	0.07	0.00	3.00	2.00	40.30	0.04	1.97
LIT-9	0.75	0.72	0.03	0.96	0.040	0.021	0.09	0.00	3.00	2.00	32.09	0.05	2.04
LIT-9	1.13	1.00	0.13	0.89	0.040	0.021	0.11	0.00	3.00	2.00	27.45	0.05	2.10
LIT-9	1.72	1.41	0.31	0.82	0.040	0.021	0.13	0.00	3.00	2.00	23.45	0.06	2.16
LIT-9	2.54	1.93	0.61	0.76	0.040	0.021	0.15	0.00	3.00	2.00	20.26	0.07	2.21
LIT-9	0.41	0.41	0.00	0.99	0.060	0.021	0.07	0.00	3.00	2.00	43.32	0.03	2.38
LIT-9	0.70	0.69	0.02	0.97	0.060	0.021	0.08	0.00	3.00	2.00	35.40	0.04	2.47
LIT-9	1.27	1.12	0.15	0.88	0.060	0.021	0.11	0.00	3.00	2.00	28.39	0.05	2.56
LIT-9	1.93	1.59	0.34	0.83	0.060	0.021	0.12	0.00	3.00	2.00	24.24	0.06	2.63
LIT-9	3.09	2.32	0.76	0.75	0.060	0.021	0.15	0.00	3.00	2.00	20.32	0.07	2.70
LIT-9	0.40	0.40	0.00	1.00	0.090	0.021	0.06	0.00	3.00	2.00	47.24	0.03	2.87
LIT-9	0.51	0.50	0.01	0.99	0.090	0.021	0.07	0.00	3.00	2.00	43.13	0.03	2.92
LIT-9	1.43	1.27	0.17	0.88	0.090	0.021	0.10	0.00	3.00	2.00	29.24	0.05	3.12
LIT-9	2.05	1.71	0.34	0.83	0.090	0.021	0.12	0.00	3.00	2.00	25.57	0.06	3.19
LIT-9	3.07	2.38	0.69	0.78	0.090	0.021	0.14	0.00	3.00	2.00	21.98	0.07	3.27
LIT-9	0.40	0.39	0.00	1.00	0.130	0.021	0.06	0.00	3.00	2.00	50.79	0.03	3.42
LIT-9	0.84	0.82	0.03	0.97	0.130	0.021	0.08	0.00	3.00	2.00	38.21	0.04	3.58
LIT-9	1.42	1.29	0.14	0.90	0.130	0.021	0.10	0.00	3.00	2.00	31.40	0.05	3.70
LIT-9	2.35	1.93	0.42	0.82	0.130	0.021	0.12	0.00	3.00	2.00	26.04	0.06	3.82
LIT-9	3.49	2.62	0.86	0.75	0.130	0.021	0.13	0.00	3.00	2.00	22.44	0.07	3.91
LIT-9	5.57	1.67	3.90	0.30	0.005	0.063	0.44	0.00	1.25	2.67	2.82	0.17	0.94
LIT-9	4.36	1.75	2.62	0.40	0.005	0.063	0.40	0.00	1.25	2.67	3.09	0.15	0.92
LIT-9	2.41	1.39	1.02	0.58	0.005	0.063	0.32	0.00	1.25	2.67	3.86	0.12	0.89
LIT-9	1.89	1.26	0.63	0.67	0.005	0.063	0.30	0.00	1.25	2.67	4.22	0.11	0.88

Continued on next page

Table 5: Literature-Derived Performance Data for Drop-Type Inlets — Continued

ID-CODE	Q_A	Q_I	Q_O	Q_R	S_0	S_x	d_a	h_b	L_I	W_I	L_R	W_R	Fr
LIT-9	1.35	1.03	0.32	0.76	0.005	0.063	0.26	0.00	1.25	2.67	4.80	0.10	0.86
LIT-9	0.58	0.56	0.03	0.96	0.005	0.063	0.19	0.00	1.25	2.67	6.57	0.07	0.82
LIT-9	0.39	0.39	0.00	1.00	0.005	0.063	0.16	0.00	1.25	2.67	7.61	0.06	0.79
LIT-9	4.16	1.78	2.38	0.43	0.010	0.063	0.35	0.00	1.25	2.67	3.58	0.13	1.27
LIT-9	2.80	1.53	1.27	0.55	0.010	0.063	0.30	0.00	1.25	2.67	4.16	0.11	1.24
LIT-9	1.89	1.27	0.62	0.67	0.010	0.063	0.26	0.00	1.25	2.67	4.82	0.10	1.21
LIT-9	1.12	0.95	0.18	0.84	0.010	0.063	0.21	0.00	1.25	2.67	5.86	0.08	1.17
LIT-9	0.57	0.55	0.02	0.96	0.010	0.063	0.17	0.00	1.25	2.67	7.56	0.06	1.13
LIT-9	5.56	1.82	3.74	0.33	0.020	0.063	0.34	0.00	1.25	2.67	3.66	0.13	1.80
LIT-9	3.32	1.67	1.65	0.50	0.020	0.063	0.28	0.00	1.25	2.67	4.44	0.11	1.74
LIT-9	2.20	1.39	0.81	0.63	0.020	0.063	0.24	0.00	1.25	2.67	5.18	0.09	1.69
LIT-9	1.78	1.23	0.55	0.69	0.020	0.063	0.22	0.00	1.25	2.67	5.61	0.08	1.67
LIT-9	0.44	0.44	0.00	1.00	0.020	0.063	0.13	0.00	1.25	2.67	9.49	0.05	1.53
LIT-9	5.27	1.56	3.71	0.30	0.040	0.063	0.29	0.00	1.25	2.67	4.25	0.11	2.48
LIT-9	0.43	0.43	0.00	1.00	0.040	0.063	0.11	0.00	1.25	2.67	10.87	0.04	2.12
LIT-9	5.47	2.03	3.44	0.37	0.060	0.063	0.28	0.00	1.25	2.67	4.52	0.10	3.00
LIT-9	4.05	2.14	1.91	0.53	0.060	0.063	0.25	0.00	1.25	2.67	5.06	0.09	2.95
LIT-9	2.41	1.56	0.86	0.64	0.060	0.063	0.20	0.00	1.25	2.67	6.15	0.08	2.85
LIT-9	1.34	1.12	0.22	0.83	0.060	0.063	0.16	0.00	1.25	2.67	7.66	0.06	2.75
LIT-9	0.44	0.44	0.00	1.00	0.060	0.063	0.11	0.00	1.25	2.67	11.67	0.04	2.56
LIT-9	5.37	1.67	3.71	0.31	0.090	0.063	0.25	0.00	1.25	2.67	4.91	0.10	3.63
LIT-9	3.49	1.97	1.52	0.56	0.090	0.063	0.22	0.00	1.25	2.67	5.77	0.08	3.53
LIT-9	1.82	1.34	0.48	0.74	0.090	0.063	0.17	0.00	1.25	2.67	7.37	0.06	3.39
LIT-9	0.85	0.78	0.07	0.92	0.090	0.063	0.13	0.00	1.25	2.67	9.79	0.05	3.23
LIT-9	0.44	0.44	0.00	1.00	0.090	0.063	0.10	0.00	1.25	2.67	12.56	0.04	3.10
LIT-9	5.51	2.14	3.37	0.39	0.130	0.063	0.24	0.00	1.25	2.67	5.21	0.09	4.31
LIT-9	4.03	1.96	2.07	0.49	0.130	0.063	0.21	0.00	1.25	2.67	5.86	0.08	4.23
LIT-9	2.52	1.56	0.95	0.62	0.130	0.063	0.18	0.00	1.25	2.67	7.00	0.07	4.11
LIT-9	1.58	1.18	0.40	0.75	0.130	0.063	0.15	0.00	1.25	2.67	8.33	0.06	3.99
LIT-9	0.47	0.47	0.00	1.00	0.130	0.063	0.09	0.00	1.25	2.67	13.16	0.04	3.70
LIT-9	2.97	1.08	1.89	0.36	0.005	0.042	0.30	0.00	1.25	2.67	4.15	0.11	0.88
LIT-9	1.97	0.96	1.01	0.49	0.005	0.042	0.26	0.00	1.25	2.67	4.83	0.10	0.86
LIT-9	1.21	0.73	0.47	0.61	0.005	0.042	0.22	0.00	1.25	2.67	5.81	0.08	0.83
LIT-9	0.67	0.54	0.13	0.80	0.005	0.042	0.17	0.00	1.25	2.67	7.23	0.06	0.80
LIT-9	0.37	0.35	0.02	0.95	0.005	0.042	0.14	0.00	1.25	2.67	9.09	0.05	0.77
LIT-9	0.23	0.22	0.00	1.00	0.005	0.042	0.11	0.00	1.25	2.67	10.89	0.04	0.75
LIT-9	2.22	1.02	1.20	0.46	0.010	0.042	0.24	0.00	1.25	2.67	5.26	0.09	1.19
LIT-9	1.51	0.86	0.65	0.57	0.010	0.042	0.21	0.00	1.25	2.67	6.08	0.08	1.17
LIT-9	0.87	0.64	0.23	0.73	0.010	0.042	0.17	0.00	1.25	2.67	7.48	0.06	1.13

Continued on next page

Table 5: Literature-Derived Performance Data for Drop-Type Inlets — Continued

ID-CODE	Q_A	Q_I	Q_O	Q_R	S_0	S_x	d_a	h_b	L_I	W_I	L_R	W_R	Fr
LIT-9	0.65	0.54	0.11	0.82	0.010	0.042	0.15	0.00	1.25	2.67	8.34	0.06	1.11
LIT-9	0.37	0.35	0.02	0.95	0.010	0.042	0.12	0.00	1.25	2.67	10.28	0.05	1.07
LIT-9	4.14	1.25	2.88	0.30	0.020	0.042	0.26	0.00	1.25	2.67	4.75	0.10	1.72
LIT-9	2.78	1.11	1.67	0.40	0.020	0.042	0.23	0.00	1.25	2.67	5.51	0.08	1.68
LIT-9	1.53	0.87	0.66	0.57	0.020	0.042	0.18	0.00	1.25	2.67	6.89	0.07	1.61
LIT-9	0.88	0.65	0.23	0.74	0.020	0.042	0.15	0.00	1.25	2.67	8.48	0.06	1.56
LIT-9	0.47	0.43	0.04	0.92	0.020	0.042	0.12	0.00	1.25	2.67	10.73	0.04	1.50
LIT-9	0.26	0.26	0.00	1.00	0.020	0.042	0.09	0.00	1.25	2.67	13.42	0.03	1.45
LIT-9	5.50	1.31	4.19	0.24	0.040	0.042	0.26	0.00	1.25	2.67	4.86	0.10	2.42
LIT-9	3.82	1.39	2.43	0.36	0.040	0.042	0.22	0.00	1.25	2.67	5.57	0.08	2.37
LIT-9	2.31	1.15	1.17	0.50	0.040	0.042	0.19	0.00	1.25	2.67	6.72	0.07	2.29
LIT-9	1.27	0.83	0.44	0.65	0.040	0.042	0.15	0.00	1.25	2.67	8.42	0.06	2.21
LIT-9	0.66	0.57	0.09	0.86	0.040	0.042	0.12	0.00	1.25	2.67	10.75	0.04	2.12
LIT-9	0.25	0.25	0.00	1.00	0.040	0.042	0.08	0.00	1.25	2.67	15.50	0.03	2.00
LIT-9	5.49	1.33	4.17	0.24	0.060	0.042	0.24	0.00	1.25	2.67	5.24	0.09	2.93
LIT-9	2.78	1.29	1.49	0.46	0.060	0.042	0.18	0.00	1.25	2.67	6.77	0.07	2.81
LIT-9	1.52	0.93	0.58	0.61	0.060	0.042	0.15	0.00	1.25	2.67	8.49	0.06	2.70
LIT-9	0.70	0.58	0.12	0.83	0.060	0.042	0.11	0.00	1.25	2.67	11.34	0.04	2.58
LIT-9	0.38	0.36	0.02	0.95	0.060	0.042	0.09	0.00	1.25	2.67	14.33	0.03	2.47
LIT-9	0.25	0.25	0.00	1.00	0.060	0.042	0.07	0.00	1.25	2.67	16.80	0.03	2.42
LIT-9	5.50	1.30	4.20	0.24	0.090	0.042	0.22	0.00	1.25	2.67	5.65	0.08	3.54
LIT-9	3.19	1.32	1.86	0.42	0.090	0.042	0.18	0.00	1.25	2.67	6.94	0.07	3.42
LIT-9	1.73	1.05	0.68	0.61	0.090	0.042	0.14	0.00	1.25	2.67	8.72	0.05	3.29
LIT-9	0.84	0.67	0.16	0.80	0.090	0.042	0.11	0.00	1.25	2.67	11.46	0.04	3.15
LIT-9	0.43	0.40	0.03	0.93	0.090	0.042	0.09	0.00	1.25	2.67	14.65	0.03	3.02
LIT-9	0.26	0.26	0.00	1.00	0.090	0.042	0.07	0.00	1.25	2.67	17.78	0.03	2.92
LIT-9	5.49	1.34	4.15	0.24	0.130	0.042	0.21	0.00	1.25	2.67	6.06	0.08	4.21
LIT-9	2.64	1.29	1.35	0.49	0.130	0.042	0.16	0.00	1.25	2.67	7.97	0.06	4.02
LIT-9	1.82	1.12	0.70	0.61	0.130	0.042	0.14	0.00	1.25	2.67	9.18	0.05	3.93
LIT-9	1.33	0.91	0.41	0.69	0.130	0.042	0.12	0.00	1.25	2.67	10.33	0.05	3.85
LIT-9	0.68	0.59	0.09	0.87	0.130	0.042	0.09	0.00	1.25	2.67	13.24	0.04	3.69
LIT-9	0.25	0.25	0.00	1.00	0.130	0.042	0.06	0.00	1.25	2.67	19.23	0.02	3.47
LIT-9	0.08	0.08	0.00	0.96	0.005	0.021	0.06	0.00	1.25	2.67	21.07	0.02	0.67
LIT-9	0.34	0.28	0.07	0.81	0.005	0.021	0.10	0.00	1.25	2.67	12.15	0.04	0.74
LIT-9	0.81	0.45	0.36	0.55	0.005	0.021	0.14	0.00	1.25	2.67	8.78	0.05	0.78
LIT-9	0.09	0.09	0.00	0.97	0.010	0.021	0.06	0.00	1.25	2.67	22.52	0.02	0.94
LIT-9	0.27	0.23	0.05	0.82	0.010	0.021	0.08	0.00	1.25	2.67	15.01	0.03	1.00
LIT-9	0.61	0.32	0.29	0.52	0.010	0.021	0.11	0.00	1.25	2.67	11.10	0.04	1.06
LIT-9	1.05	0.42	0.64	0.39	0.010	0.021	0.14	0.00	1.25	2.67	9.06	0.05	1.09

Continued on next page

Table 5: Literature-Derived Performance Data for Drop-Type Inlets — Continued

ID-CODE	Q_A	Q_I	Q_O	Q_R	S_0	S_x	d_a	h_b	L_I	W_I	L_R	W_R	Fr
LIT-9	0.12	0.12	0.00	1.00	0.020	0.021	0.05	0.00	1.25	2.67	23.59	0.02	1.32
LIT-9	0.27	0.22	0.05	0.82	0.020	0.021	0.07	0.00	1.25	2.67	17.30	0.03	1.39
LIT-9	0.52	0.29	0.22	0.57	0.020	0.021	0.09	0.00	1.25	2.67	13.46	0.03	1.44
LIT-9	0.90	0.41	0.50	0.45	0.020	0.021	0.11	0.00	1.25	2.67	10.92	0.04	1.50
LIT-9	1.34	0.47	0.87	0.35	0.020	0.021	0.13	0.00	1.25	2.67	9.43	0.05	1.53
LIT-9	0.12	0.12	0.00	0.99	0.040	0.021	0.05	0.00	1.25	2.67	26.43	0.02	1.83
LIT-9	0.29	0.24	0.05	0.83	0.040	0.021	0.07	0.00	1.25	2.67	18.99	0.02	1.93
LIT-9	0.42	0.30	0.12	0.71	0.040	0.021	0.08	0.00	1.25	2.67	16.55	0.03	1.98
LIT-9	0.49	0.32	0.17	0.66	0.040	0.021	0.08	0.00	1.25	2.67	15.67	0.03	1.99
LIT-9	0.80	0.38	0.42	0.48	0.040	0.021	0.10	0.00	1.25	2.67	13.02	0.04	2.05
LIT-9	2.26	0.53	1.72	0.24	0.040	0.021	0.14	0.00	1.25	2.67	8.82	0.05	2.19
LIT-9	0.10	0.10	0.00	0.97	0.060	0.021	0.04	0.00	1.25	2.67	30.34	0.02	2.18
LIT-9	0.46	0.30	0.16	0.65	0.060	0.021	0.07	0.00	1.25	2.67	17.34	0.03	2.40
LIT-9	0.87	0.40	0.47	0.46	0.060	0.021	0.09	0.00	1.25	2.67	13.61	0.03	2.50
LIT-9	1.62	0.51	1.10	0.32	0.060	0.021	0.12	0.00	1.25	2.67	10.80	0.04	2.60
LIT-9	2.38	0.56	1.82	0.24	0.060	0.021	0.13	0.00	1.25	2.67	9.33	0.05	2.66
LIT-9	0.09	0.09	0.00	0.97	0.090	0.021	0.04	0.00	1.25	2.67	33.97	0.01	2.64
LIT-9	0.26	0.22	0.04	0.86	0.090	0.021	0.05	0.00	1.25	2.67	23.07	0.02	2.81
LIT-9	0.50	0.33	0.17	0.65	0.090	0.021	0.07	0.00	1.25	2.67	18.04	0.03	2.92
LIT-9	1.01	0.44	0.57	0.43	0.090	0.021	0.09	0.00	1.25	2.67	13.88	0.03	3.05
LIT-9	1.65	0.55	1.09	0.34	0.090	0.021	0.11	0.00	1.25	2.67	11.57	0.04	3.14
LIT-9	3.01	0.65	2.37	0.21	0.090	0.021	0.14	0.00	1.25	2.67	9.22	0.05	3.27
LIT-9	0.15	0.15	0.00	1.00	0.130	0.021	0.04	0.00	1.25	2.67	30.66	0.02	3.22
LIT-9	0.33	0.27	0.06	0.83	0.130	0.021	0.06	0.00	1.25	2.67	22.72	0.02	3.38
LIT-9	0.45	0.31	0.14	0.69	0.130	0.021	0.06	0.00	1.25	2.67	20.10	0.02	3.45
LIT-9	0.80	0.39	0.41	0.49	0.130	0.021	0.08	0.00	1.25	2.67	16.23	0.03	3.57
LIT-9	1.43	0.53	0.89	0.37	0.130	0.021	0.10	0.00	1.25	2.67	13.08	0.04	3.70
LIT-9	2.86	0.67	2.19	0.24	0.130	0.021	0.12	0.00	1.25	2.67	10.08	0.05	3.87
LIT-9	5.27	2.39	2.89	0.45	0.005	0.063	0.43	0.00	1.25	2.00	2.88	0.22	0.93
LIT-9	2.87	1.78	1.09	0.62	0.005	0.063	0.35	0.00	1.25	2.00	3.62	0.17	0.90
LIT-9	2.49	1.61	0.88	0.65	0.005	0.063	0.33	0.00	1.25	2.00	3.81	0.16	0.89
LIT-9	1.55	1.21	0.34	0.78	0.005	0.063	0.27	0.00	1.25	2.00	4.55	0.14	0.87
LIT-9	0.29	0.29	0.00	1.00	0.005	0.063	0.15	0.00	1.25	2.00	8.51	0.07	0.78
LIT-9	5.28	2.39	2.89	0.45	0.010	0.063	0.38	0.00	1.25	2.00	3.28	0.19	1.29
LIT-9	3.35	1.97	1.37	0.59	0.010	0.063	0.32	0.00	1.25	2.00	3.89	0.16	1.26
LIT-9	2.37	1.55	0.82	0.65	0.010	0.063	0.28	0.00	1.25	2.00	4.42	0.14	1.23
LIT-9	1.23	0.98	0.24	0.80	0.010	0.063	0.22	0.00	1.25	2.00	5.67	0.11	1.18
LIT-9	0.30	0.30	0.00	0.99	0.010	0.063	0.13	0.00	1.25	2.00	9.62	0.06	1.08
LIT-9	5.57	2.70	2.87	0.49	0.020	0.063	0.34	0.00	1.25	2.00	3.66	0.17	1.80

Continued on next page

Table 5: Literature-Derived Performance Data for Drop-Type Inlets — Continued

ID-CODE	Q_A	Q_I	Q_O	Q_R	S_0	S_x	d_a	h_b	L_I	W_I	L_R	W_R	Fr
LIT-9	3.97	2.29	1.68	0.58	0.020	0.063	0.30	0.00	1.25	2.00	4.15	0.15	1.76
LIT-9	2.22	1.54	0.68	0.69	0.020	0.063	0.24	0.00	1.25	2.00	5.16	0.12	1.70
LIT-9	1.12	0.94	0.18	0.84	0.020	0.063	0.19	0.00	1.25	2.00	6.67	0.09	1.62
LIT-9	0.29	0.29	0.00	1.00	0.020	0.063	0.11	0.00	1.25	2.00	11.03	0.06	1.50
LIT-9	5.53	2.84	2.69	0.51	0.040	0.063	0.30	0.00	1.25	2.00	4.18	0.15	2.48
LIT-9	3.26	2.06	1.20	0.63	0.040	0.063	0.25	0.00	1.25	2.00	5.09	0.12	2.40
LIT-9	2.29	1.65	0.64	0.72	0.040	0.063	0.22	0.00	1.25	2.00	5.81	0.11	2.35
LIT-9	1.44	1.16	0.29	0.80	0.040	0.063	0.18	0.00	1.25	2.00	6.91	0.09	2.28
LIT-9	0.33	0.33	0.00	1.00	0.040	0.063	0.10	0.00	1.25	2.00	12.05	0.05	2.08
LIT-9	5.46	2.64	2.83	0.48	0.060	0.063	0.28	0.00	1.25	2.00	4.52	0.14	3.00
LIT-9	2.95	2.02	0.94	0.68	0.060	0.063	0.22	0.00	1.25	2.00	5.70	0.11	2.89
LIT-9	1.32	1.14	0.19	0.86	0.060	0.063	0.16	0.00	1.25	2.00	7.70	0.08	2.75
LIT-9	0.28	0.28	0.00	1.00	0.060	0.063	0.09	0.00	1.25	2.00	13.76	0.05	2.50
LIT-9	5.39	2.38	3.01	0.44	0.090	0.063	0.25	0.00	1.25	2.00	4.91	0.13	3.63
LIT-9	3.19	2.06	1.13	0.65	0.090	0.063	0.21	0.00	1.25	2.00	5.98	0.10	3.51
LIT-9	1.52	1.29	0.23	0.85	0.090	0.063	0.16	0.00	1.25	2.00	7.89	0.08	3.35
LIT-9	0.38	0.38	0.00	0.99	0.090	0.063	0.09	0.00	1.25	2.00	13.24	0.05	3.08
LIT-9	5.27	2.19	3.08	0.42	0.130	0.063	0.24	0.00	1.25	2.00	5.30	0.12	4.30
LIT-9	3.81	2.08	1.73	0.55	0.130	0.063	0.21	0.00	1.25	2.00	5.99	0.10	4.22
LIT-9	2.93	1.83	1.11	0.62	0.130	0.063	0.19	0.00	1.25	2.00	6.60	0.09	4.15
LIT-9	1.26	1.10	0.15	0.88	0.130	0.063	0.14	0.00	1.25	2.00	9.07	0.07	3.93
LIT-9	0.31	0.31	0.00	1.00	0.130	0.063	0.08	0.00	1.25	2.00	15.42	0.04	3.61
LIT-9	2.58	1.39	1.19	0.54	0.005	0.042	0.29	0.00	1.25	2.00	4.37	0.14	0.87
LIT-9	1.98	1.19	0.79	0.60	0.005	0.042	0.26	0.00	1.25	2.00	4.82	0.13	0.86
LIT-9	1.40	0.93	0.47	0.66	0.005	0.042	0.23	0.00	1.25	2.00	5.50	0.11	0.84
LIT-9	0.69	0.56	0.14	0.80	0.005	0.042	0.17	0.00	1.25	2.00	7.15	0.09	0.80
LIT-9	0.28	0.27	0.01	0.98	0.005	0.042	0.12	0.00	1.25	2.00	10.09	0.06	0.76
LIT-9	3.09	1.54	1.55	0.50	0.010	0.042	0.27	0.00	1.25	2.00	4.65	0.13	1.22
LIT-9	1.96	1.15	0.81	0.58	0.010	0.042	0.23	0.00	1.25	2.00	5.51	0.11	1.19
LIT-9	1.22	0.81	0.41	0.66	0.010	0.042	0.19	0.00	1.25	2.00	6.59	0.09	1.15
LIT-9	0.91	0.67	0.23	0.74	0.010	0.042	0.17	0.00	1.25	2.00	7.36	0.08	1.13
LIT-9	0.70	0.56	0.14	0.80	0.010	0.042	0.15	0.00	1.25	2.00	8.13	0.08	1.11
LIT-9	0.22	0.22	0.00	0.99	0.010	0.042	0.10	0.00	1.25	2.00	12.54	0.05	1.03
LIT-9	4.14	1.95	2.19	0.47	0.020	0.042	0.26	0.00	1.25	2.00	4.74	0.13	1.72
LIT-9	2.74	1.47	1.26	0.54	0.020	0.042	0.23	0.00	1.25	2.00	5.54	0.11	1.68
LIT-9	1.55	1.02	0.54	0.65	0.020	0.042	0.18	0.00	1.25	2.00	6.85	0.09	1.62
LIT-9	0.89	0.66	0.22	0.75	0.020	0.042	0.15	0.00	1.25	2.00	8.46	0.07	1.56
LIT-9	0.65	0.52	0.12	0.81	0.020	0.042	0.13	0.00	1.25	2.00	9.52	0.07	1.53
LIT-9	0.12	0.11	0.00	0.99	0.020	0.042	0.07	0.00	1.25	2.00	18.18	0.03	1.38

Continued on next page

Table 5: Literature-Derived Performance Data for Drop-Type Inlets — Continued

ID-CODE	Q_A	Q_I	Q_O	Q_R	S_0	S_x	d_a	h_b	L_I	W_I	L_R	W_R	Fr
LIT-9	5.27	2.12	3.16	0.40	0.040	0.042	0.25	0.00	1.25	2.00	4.93	0.13	2.42
LIT-9	2.25	1.38	0.87	0.61	0.040	0.042	0.18	0.00	1.25	2.00	6.79	0.09	2.29
LIT-9	1.08	0.81	0.27	0.75	0.040	0.042	0.14	0.00	1.25	2.00	8.93	0.07	2.19
LIT-9	0.74	0.63	0.12	0.84	0.040	0.042	0.12	0.00	1.25	2.00	10.28	0.06	2.14
LIT-9	0.18	0.18	0.00	1.00	0.040	0.042	0.07	0.00	1.25	2.00	17.54	0.04	1.96
LIT-9	5.46	2.31	3.15	0.42	0.060	0.042	0.24	0.00	1.25	2.00	5.25	0.12	2.93
LIT-9	4.42	2.16	2.26	0.49	0.060	0.042	0.22	0.00	1.25	2.00	5.69	0.11	2.89
LIT-9	2.80	1.66	1.13	0.60	0.060	0.042	0.19	0.00	1.25	2.00	6.75	0.09	2.81
LIT-9	1.64	1.14	0.49	0.70	0.060	0.042	0.15	0.00	1.25	2.00	8.26	0.08	2.72
LIT-9	0.75	0.63	0.12	0.84	0.060	0.042	0.11	0.00	1.25	2.00	11.08	0.06	2.59
LIT-9	0.21	0.21	0.00	1.00	0.060	0.042	0.07	0.00	1.25	2.00	17.82	0.04	2.39
LIT-9	5.37	2.17	3.19	0.40	0.090	0.042	0.22	0.00	1.25	2.00	5.71	0.11	3.54
LIT-9	2.92	1.70	1.22	0.58	0.090	0.042	0.17	0.00	1.25	2.00	7.17	0.09	3.40
LIT-9	1.72	1.22	0.50	0.71	0.090	0.042	0.14	0.00	1.25	2.00	8.74	0.07	3.29
LIT-9	0.20	0.20	0.00	1.00	0.090	0.042	0.06	0.00	1.25	2.00	19.65	0.03	2.88
LIT-9	5.28	2.12	3.15	0.40	0.130	0.042	0.20	0.00	1.25	2.00	6.15	0.10	4.20
LIT-9	2.48	1.48	1.00	0.60	0.130	0.042	0.15	0.00	1.25	2.00	8.16	0.08	4.00
LIT-9	1.95	1.33	0.62	0.68	0.130	0.042	0.14	0.00	1.25	2.00	8.94	0.07	3.94
LIT-9	0.91	0.76	0.14	0.84	0.130	0.042	0.10	0.00	1.25	2.00	11.91	0.05	3.76
LIT-9	0.11	0.11	0.00	0.99	0.130	0.042	0.05	0.00	1.25	2.00	25.90	0.02	3.32
LIT-9	0.75	0.45	0.31	0.59	0.005	0.021	0.14	0.00	1.25	2.00	9.03	0.07	0.77
LIT-9	0.64	0.40	0.24	0.63	0.005	0.021	0.13	0.00	1.25	2.00	9.56	0.07	0.76
LIT-9	0.52	0.35	0.17	0.67	0.005	0.021	0.12	0.00	1.25	2.00	10.40	0.06	0.75
LIT-9	0.31	0.25	0.07	0.79	0.005	0.021	0.10	0.00	1.25	2.00	12.52	0.05	0.73
LIT-9	0.28	0.23	0.05	0.83	0.005	0.021	0.10	0.00	1.25	2.00	13.10	0.05	0.73
LIT-9	0.07	0.06	0.00	0.98	0.005	0.021	0.06	0.00	1.25	2.00	22.53	0.03	0.67
LIT-9	0.97	0.53	0.44	0.55	0.010	0.021	0.13	0.00	1.25	2.00	9.34	0.07	1.09
LIT-9	0.73	0.45	0.29	0.61	0.010	0.021	0.12	0.00	1.25	2.00	10.38	0.06	1.07
LIT-9	0.65	0.41	0.24	0.64	0.010	0.021	0.12	0.00	1.25	2.00	10.85	0.06	1.06
LIT-9	0.58	0.39	0.19	0.68	0.010	0.021	0.11	0.00	1.25	2.00	11.32	0.06	1.05
LIT-9	0.28	0.24	0.05	0.84	0.010	0.021	0.08	0.00	1.25	2.00	14.81	0.04	1.01
LIT-9	0.10	0.10	0.00	0.99	0.010	0.021	0.06	0.00	1.25	2.00	21.61	0.03	0.94
LIT-9	1.37	0.67	0.70	0.49	0.020	0.021	0.13	0.00	1.25	2.00	9.35	0.07	1.54
LIT-9	0.82	0.47	0.35	0.57	0.020	0.021	0.11	0.00	1.25	2.00	11.34	0.06	1.49
LIT-9	0.48	0.33	0.15	0.68	0.020	0.021	0.09	0.00	1.25	2.00	13.84	0.05	1.44
LIT-9	0.26	0.22	0.04	0.85	0.020	0.021	0.07	0.00	1.25	2.00	17.40	0.04	1.39
LIT-9	0.11	0.11	0.00	0.99	0.020	0.021	0.05	0.00	1.25	2.00	24.14	0.03	1.31
LIT-9	1.92	0.89	1.03	0.46	0.040	0.021	0.13	0.00	1.25	2.00	9.38	0.07	2.17
LIT-9	1.23	0.67	0.56	0.54	0.040	0.021	0.11	0.00	1.25	2.00	11.09	0.06	2.11

Continued on next page

Table 5: Literature-Derived Performance Data for Drop-Type Inlets — Continued

ID-CODE	Q_A	Q_I	Q_O	Q_R	S_0	S_x	d_a	h_b	L_I	W_I	L_R	W_R	Fr
LIT-9	0.59	0.40	0.19	0.68	0.040	0.021	0.09	0.00	1.25	2.00	14.58	0.04	2.02
LIT-9	0.45	0.34	0.11	0.75	0.040	0.021	0.08	0.00	1.25	2.00	16.21	0.04	1.98
LIT-9	0.13	0.13	0.00	0.98	0.040	0.021	0.05	0.00	1.25	2.00	25.95	0.02	1.84
LIT-9	2.34	1.05	1.30	0.45	0.060	0.021	0.13	0.00	1.25	2.00	9.39	0.07	2.66
LIT-9	1.39	0.73	0.66	0.53	0.060	0.021	0.11	0.00	1.25	2.00	11.41	0.05	2.57
LIT-9	0.77	0.48	0.29	0.62	0.060	0.021	0.09	0.00	1.25	2.00	14.29	0.04	2.48
LIT-9	0.47	0.34	0.13	0.73	0.060	0.021	0.07	0.00	1.25	2.00	17.15	0.04	2.41
LIT-9	0.13	0.13	0.00	0.98	0.060	0.021	0.05	0.00	1.25	2.00	27.59	0.02	2.22
LIT-9	3.16	1.29	1.87	0.41	0.090	0.021	0.14	0.00	1.25	2.00	9.06	0.07	3.27
LIT-9	1.60	0.84	0.76	0.53	0.090	0.021	0.11	0.00	1.25	2.00	11.68	0.05	3.14
LIT-9	0.98	0.57	0.41	0.58	0.090	0.021	0.09	0.00	1.25	2.00	14.08	0.04	3.04
LIT-9	0.57	0.41	0.16	0.72	0.090	0.021	0.07	0.00	1.25	2.00	17.26	0.04	2.94
LIT-9	0.28	0.24	0.04	0.85	0.090	0.021	0.06	0.00	1.25	2.00	22.41	0.03	2.82
LIT-9	0.14	0.13	0.00	0.98	0.090	0.021	0.04	0.00	1.25	2.00	29.49	0.02	2.68
LIT-9	2.83	1.27	1.56	0.45	0.130	0.021	0.12	0.00	1.25	2.00	10.12	0.06	3.86
LIT-9	1.62	0.83	0.78	0.52	0.130	0.021	0.10	0.00	1.25	2.00	12.47	0.05	3.73
LIT-9	1.16	0.67	0.49	0.58	0.130	0.021	0.09	0.00	1.25	2.00	14.13	0.04	3.66
LIT-9	0.98	0.59	0.39	0.60	0.130	0.021	0.08	0.00	1.25	2.00	15.03	0.04	3.62
LIT-9	0.51	0.37	0.14	0.73	0.130	0.021	0.07	0.00	1.25	2.00	19.22	0.03	3.47
LIT-9	0.15	0.14	0.00	0.98	0.130	0.021	0.04	0.00	1.25	2.00	30.66	0.02	3.22
LIT-10	5.23	4.73	0.50	0.90	0.005	0.063	0.43	0.00	3.00	4.00	6.93	0.11	0.93
LIT-10	4.07	3.84	0.23	0.94	0.005	0.063	0.39	0.00	3.00	4.00	7.61	0.10	0.92
LIT-10	2.98	2.93	0.05	0.98	0.005	0.063	0.35	0.00	3.00	4.00	8.56	0.09	0.90
LIT-10	2.27	2.27	0.00	1.00	0.005	0.063	0.32	0.00	3.00	4.00	9.48	0.08	0.89
LIT-10	5.55	5.03	0.53	0.91	0.010	0.063	0.39	0.00	3.00	4.00	7.71	0.10	1.30
LIT-10	4.22	3.99	0.23	0.94	0.010	0.063	0.35	0.00	3.00	4.00	8.55	0.09	1.27
LIT-10	3.26	3.19	0.07	0.98	0.010	0.063	0.32	0.00	3.00	4.00	9.42	0.08	1.25
LIT-10	2.55	2.54	0.01	1.00	0.010	0.063	0.29	0.00	3.00	4.00	10.33	0.07	1.24
LIT-10	2.18	2.18	0.00	1.00	0.010	0.063	0.27	0.00	3.00	4.00	10.95	0.07	1.22
LIT-10	5.53	5.10	0.43	0.92	0.020	0.063	0.34	0.00	3.00	4.00	8.80	0.09	1.79
LIT-10	4.26	4.11	0.15	0.96	0.020	0.063	0.31	0.00	3.00	4.00	9.70	0.08	1.77
LIT-10	3.01	3.00	0.01	1.00	0.020	0.063	0.27	0.00	3.00	4.00	11.06	0.07	1.73
LIT-10	2.50	2.50	0.00	1.00	0.020	0.063	0.25	0.00	3.00	4.00	11.86	0.06	1.71
LIT-10	5.47	5.11	0.35	0.94	0.040	0.063	0.30	0.00	3.00	4.00	10.06	0.07	2.48
LIT-10	4.28	4.19	0.09	0.98	0.040	0.063	0.27	0.00	3.00	4.00	11.03	0.07	2.44
LIT-10	3.25	3.24	0.01	1.00	0.040	0.063	0.25	0.00	3.00	4.00	12.23	0.06	2.40
LIT-10	2.26	2.26	0.00	1.00	0.040	0.063	0.21	0.00	3.00	4.00	14.02	0.05	2.35
LIT-10	5.43	4.98	0.45	0.92	0.060	0.063	0.28	0.00	3.00	4.00	10.88	0.07	3.00
LIT-10	3.93	3.83	0.10	0.98	0.060	0.063	0.24	0.00	3.00	4.00	12.29	0.06	2.94

Continued on next page

Table 5: Literature-Derived Performance Data for Drop-Type Inlets — Continued

ID-CODE	Q_A	Q_I	Q_O	Q_R	S_0	S_x	d_a	h_b	L_I	W_I	L_R	W_R	Fr
LIT-10	3.22	3.21	0.01	1.00	0.060	0.063	0.23	0.00	3.00	4.00	13.24	0.06	2.90
LIT-10	2.55	2.54	0.00	1.00	0.060	0.063	0.21	0.00	3.00	4.00	14.45	0.05	2.86
LIT-10	5.30	4.65	0.65	0.88	0.090	0.063	0.25	0.00	3.00	4.00	11.85	0.06	3.62
LIT-10	4.50	4.14	0.37	0.92	0.090	0.063	0.24	0.00	3.00	4.00	12.60	0.06	3.59
LIT-10	3.51	3.38	0.13	0.96	0.090	0.063	0.22	0.00	3.00	4.00	13.83	0.05	3.53
LIT-10	2.63	2.60	0.03	0.99	0.090	0.063	0.19	0.00	3.00	4.00	15.42	0.05	3.47
LIT-10	5.24	4.32	0.91	0.83	0.130	0.063	0.24	0.00	3.00	4.00	12.76	0.06	4.30
LIT-10	3.64	3.31	0.32	0.91	0.130	0.063	0.21	0.00	3.00	4.00	14.63	0.05	4.20
LIT-10	3.04	2.87	0.16	0.95	0.130	0.063	0.19	0.00	3.00	4.00	15.64	0.05	4.16
LIT-10	1.91	1.90	0.01	1.00	0.130	0.063	0.16	0.00	3.00	4.00	18.62	0.04	4.04
LIT-10	2.58	2.41	0.18	0.93	0.005	0.042	0.29	0.00	3.00	4.00	10.48	0.07	0.87
LIT-10	2.20	2.09	0.11	0.95	0.005	0.042	0.26	0.00	3.00	4.00	11.48	0.07	0.93
LIT-10	1.79	1.75	0.04	0.98	0.005	0.042	0.25	0.00	3.00	4.00	12.03	0.06	0.85
LIT-10	1.43	1.42	0.01	1.00	0.005	0.042	0.23	0.00	3.00	4.00	13.08	0.06	0.84
LIT-10	3.55	3.11	0.44	0.88	0.010	0.042	0.28	0.00	3.00	4.00	10.59	0.07	1.23
LIT-10	2.59	2.40	0.19	0.93	0.010	0.042	0.25	0.00	3.00	4.00	11.92	0.06	1.21
LIT-10	2.06	1.99	0.07	0.97	0.010	0.042	0.23	0.00	3.00	4.00	12.98	0.06	1.19
LIT-10	1.07	1.07	0.00	1.00	0.010	0.042	0.18	0.00	3.00	4.00	16.62	0.05	1.14
LIT-10	4.87	4.08	0.79	0.84	0.020	0.042	0.28	0.00	3.00	4.00	10.71	0.07	1.74
LIT-10	3.65	3.26	0.40	0.89	0.020	0.042	0.25	0.00	3.00	4.00	11.93	0.06	1.71
LIT-10	2.73	2.57	0.16	0.94	0.020	0.042	0.23	0.00	3.00	4.00	13.31	0.06	1.68
LIT-10	1.90	1.87	0.02	0.99	0.020	0.042	0.20	0.00	3.00	4.00	15.25	0.05	1.64
LIT-10	1.11	1.11	0.00	1.00	0.020	0.042	0.16	0.00	3.00	4.00	18.65	0.04	1.58
LIT-10	5.51	4.66	0.85	0.85	0.040	0.042	0.26	0.00	3.00	4.00	11.64	0.06	2.42
LIT-10	4.09	3.68	0.40	0.90	0.040	0.042	0.23	0.00	3.00	4.00	13.03	0.06	2.38
LIT-10	2.85	2.73	0.12	0.96	0.040	0.042	0.20	0.00	3.00	4.00	14.91	0.05	2.32
LIT-10	2.22	2.18	0.04	0.98	0.040	0.042	0.18	0.00	3.00	4.00	16.37	0.05	2.29
LIT-10	1.30	1.30	0.00	1.00	0.040	0.042	0.15	0.00	3.00	4.00	20.03	0.04	2.21
LIT-10	5.45	4.63	0.82	0.85	0.060	0.042	0.24	0.00	3.00	4.00	12.62	0.06	2.93
LIT-10	4.24	3.83	0.41	0.90	0.060	0.042	0.22	0.00	3.00	4.00	13.87	0.05	2.88
LIT-10	3.23	3.06	0.17	0.95	0.060	0.042	0.20	0.00	3.00	4.00	15.36	0.05	2.83
LIT-10	1.99	1.98	0.01	1.00	0.060	0.042	0.16	0.00	3.00	4.00	18.40	0.04	2.75
LIT-10	1.44	1.44	0.00	1.00	0.060	0.042	0.14	0.00	3.00	4.00	20.79	0.04	2.69
LIT-10	5.38	4.54	0.83	0.85	0.090	0.042	0.22	0.00	3.00	4.00	13.68	0.05	3.54
LIT-10	4.15	3.77	0.37	0.91	0.090	0.042	0.20	0.00	3.00	4.00	15.08	0.05	3.48
LIT-10	2.75	2.68	0.08	0.97	0.090	0.042	0.17	0.00	3.00	4.00	17.59	0.04	3.39
LIT-10	1.99	1.98	0.01	1.00	0.090	0.042	0.15	0.00	3.00	4.00	19.87	0.04	3.32
LIT-10	1.50	1.50	0.00	1.00	0.090	0.042	0.14	0.00	3.00	4.00	22.09	0.03	3.27
LIT-10	5.25	4.28	0.97	0.82	0.130	0.042	0.20	0.00	3.00	4.00	14.79	0.05	4.20

Continued on next page

Table 5: Literature-Derived Performance Data for Drop-Type Inlets — Continued

ID-CODE	Q_A	Q_I	Q_O	Q_R	S_0	S_x	d_a	h_b	L_I	W_I	L_R	W_R	Fr
LIT-10	3.99	3.60	0.39	0.90	0.130	0.042	0.18	0.00	3.00	4.00	16.39	0.05	4.12
LIT-10	2.94	2.82	0.11	0.96	0.130	0.042	0.16	0.00	3.00	4.00	18.39	0.04	4.05
LIT-10	2.02	2.00	0.02	0.99	0.130	0.042	0.14	0.00	3.00	4.00	21.16	0.04	3.95
LIT-10	1.47	1.47	0.00	1.00	0.130	0.042	0.13	0.00	3.00	4.00	23.83	0.03	3.88
LIT-10	1.19	1.07	0.12	0.90	0.005	0.208	0.39	0.00	3.00	4.00	7.68	0.10	0.92
LIT-10	0.92	0.87	0.05	0.94	0.005	0.208	0.35	0.00	3.00	4.00	8.48	0.09	0.90
LIT-10	0.62	0.61	0.01	0.99	0.005	0.208	0.31	0.00	3.00	4.00	9.81	0.08	0.88
LIT-10	0.36	0.36	0.00	1.00	0.005	0.208	0.25	0.00	3.00	4.00	12.06	0.06	0.85
LIT-10	0.85	0.81	0.04	0.96	0.010	0.208	0.30	0.00	3.00	4.00	9.94	0.08	1.24
LIT-10	0.74	0.72	0.02	0.97	0.010	0.208	0.29	0.00	3.00	4.00	10.48	0.07	1.23
LIT-10	0.60	0.59	0.01	0.99	0.010	0.208	0.26	0.00	3.00	4.00	11.33	0.07	1.22
LIT-10	0.31	0.31	0.00	1.00	0.010	0.208	0.21	0.00	3.00	4.00	14.43	0.05	1.17
LIT-10	1.61	1.39	0.22	0.87	0.020	0.208	0.34	0.00	3.00	4.00	8.90	0.08	1.79
LIT-10	1.21	1.10	0.11	0.91	0.020	0.208	0.30	0.00	3.00	4.00	9.90	0.08	1.76
LIT-10	0.77	0.75	0.02	0.98	0.020	0.208	0.25	0.00	3.00	4.00	11.77	0.06	1.71
LIT-10	0.39	0.39	0.00	1.00	0.020	0.208	0.20	0.00	3.00	4.00	15.15	0.05	1.64
LIT-10	2.39	1.94	0.46	0.81	0.040	0.208	0.34	0.00	3.00	4.00	8.74	0.09	2.54
LIT-10	1.72	1.47	0.25	0.85	0.040	0.208	0.30	0.00	3.00	4.00	9.89	0.08	2.49
LIT-10	1.08	1.02	0.06	0.95	0.040	0.208	0.25	0.00	3.00	4.00	11.78	0.06	2.42
LIT-10	0.72	0.71	0.01	0.99	0.040	0.208	0.22	0.00	3.00	4.00	13.75	0.05	2.36
LIT-10	0.40	0.40	0.00	1.00	0.040	0.208	0.18	0.00	3.00	4.00	17.02	0.04	2.28
LIT-10	2.94	2.31	0.64	0.78	0.060	0.208	0.34	0.00	3.00	4.00	8.72	0.09	3.11
LIT-10	2.05	1.72	0.33	0.84	0.060	0.208	0.30	0.00	3.00	4.00	10.00	0.08	3.04
LIT-10	1.37	1.25	0.12	0.91	0.060	0.208	0.26	0.00	3.00	4.00	11.61	0.06	2.97
LIT-10	0.64	0.64	0.01	0.99	0.060	0.208	0.19	0.00	3.00	4.00	15.43	0.05	2.83
LIT-10	0.48	0.48	0.00	1.00	0.060	0.208	0.17	0.00	3.00	4.00	17.23	0.04	2.78
LIT-10	3.00	2.40	0.60	0.80	0.090	0.208	0.32	0.00	3.00	4.00	9.35	0.08	3.77
LIT-10	2.02	1.74	0.28	0.86	0.090	0.208	0.28	0.00	3.00	4.00	10.85	0.07	3.68
LIT-10	1.32	1.23	0.09	0.93	0.090	0.208	0.24	0.00	3.00	4.00	12.73	0.06	3.58
LIT-10	0.75	0.74	0.01	0.99	0.090	0.208	0.19	0.00	3.00	4.00	15.69	0.05	3.46
LIT-10	0.37	0.37	0.00	1.00	0.090	0.208	0.15	0.00	3.00	4.00	20.40	0.04	3.31
LIT-10	3.51	2.77	0.74	0.79	0.130	0.208	0.32	0.00	3.00	4.00	9.44	0.08	4.52
LIT-10	2.32	1.97	0.34	0.85	0.130	0.208	0.27	0.00	3.00	4.00	11.03	0.07	4.41
LIT-10	1.54	1.41	0.13	0.91	0.130	0.208	0.23	0.00	3.00	4.00	12.85	0.06	4.30
LIT-10	0.89	0.88	0.02	0.98	0.130	0.208	0.19	0.00	3.00	4.00	15.77	0.05	4.15
LIT-10	0.25	0.25	0.00	1.00	0.130	0.208	0.12	0.00	3.00	4.00	25.40	0.03	3.84
LIT-10	5.24	4.39	0.85	0.84	0.005	0.063	0.43	0.00	3.00	2.00	6.92	0.22	0.93
LIT-10	3.72	3.32	0.40	0.89	0.005	0.063	0.38	0.00	3.00	2.00	7.87	0.19	0.91
LIT-10	2.24	2.17	0.06	0.97	0.005	0.063	0.31	0.00	3.00	2.00	9.53	0.16	0.89

Continued on next page

Table 5: Literature-Derived Performance Data for Drop-Type Inlets — Continued

ID-CODE	Q_A	Q_I	Q_O	Q_R	S_0	S_x	d_a	h_b	L_I	W_I	L_R	W_R	Fr
LIT-10	1.41	1.41	0.00	1.00	0.005	0.063	0.27	0.00	3.00	2.00	11.32	0.13	0.86
LIT-10	5.59	4.72	0.87	0.84	0.010	0.063	0.39	0.00	3.00	2.00	7.69	0.19	1.30
LIT-10	3.83	3.49	0.34	0.91	0.010	0.063	0.34	0.00	3.00	2.00	8.87	0.17	1.27
LIT-10	3.01	2.84	0.17	0.94	0.010	0.063	0.31	0.00	3.00	2.00	9.70	0.15	1.25
LIT-10	2.22	2.19	0.03	0.98	0.010	0.063	0.28	0.00	3.00	2.00	10.87	0.14	1.23
LIT-10	1.41	1.41	0.00	1.00	0.010	0.063	0.23	0.00	3.00	2.00	12.90	0.12	1.19
LIT-10	5.52	4.64	0.88	0.84	0.020	0.063	0.34	0.00	3.00	2.00	8.80	0.17	1.79
LIT-10	4.27	3.84	0.43	0.90	0.020	0.063	0.31	0.00	3.00	2.00	9.69	0.15	1.77
LIT-10	2.98	2.88	0.11	0.96	0.020	0.063	0.27	0.00	3.00	2.00	11.09	0.14	1.73
LIT-10	1.79	1.79	0.00	1.00	0.020	0.063	0.22	0.00	3.00	2.00	13.44	0.11	1.67
LIT-10	1.40	1.40	0.00	1.00	0.020	0.063	0.20	0.00	3.00	2.00	14.73	0.10	1.65
LIT-10	5.50	4.34	1.16	0.79	0.040	0.063	0.30	0.00	3.00	2.00	10.04	0.15	2.48
LIT-10	4.38	3.70	0.68	0.84	0.040	0.063	0.27	0.00	3.00	2.00	10.94	0.14	2.45
LIT-10	3.04	2.79	0.25	0.92	0.040	0.063	0.24	0.00	3.00	2.00	12.54	0.12	2.39
LIT-10	2.19	2.14	0.05	0.98	0.040	0.063	0.21	0.00	3.00	2.00	14.18	0.11	2.34
LIT-10	1.23	1.23	0.00	1.00	0.040	0.063	0.17	0.00	3.00	2.00	17.61	0.09	2.26
LIT-10	5.41	3.89	1.52	0.72	0.060	0.063	0.28	0.00	3.00	2.00	10.90	0.14	3.00
LIT-10	4.05	3.25	0.80	0.80	0.060	0.063	0.25	0.00	3.00	2.00	12.15	0.12	2.95
LIT-10	2.96	2.52	0.44	0.85	0.060	0.063	0.22	0.00	3.00	2.00	13.66	0.11	2.89
LIT-10	2.12	1.93	0.19	0.91	0.060	0.063	0.19	0.00	3.00	2.00	15.49	0.10	2.83
LIT-10	1.49	1.44	0.05	0.97	0.060	0.063	0.17	0.00	3.00	2.00	17.70	0.08	2.77
LIT-10	0.88	0.88	0.00	1.00	0.060	0.063	0.14	0.00	3.00	2.00	21.54	0.07	2.68
LIT-10	5.32	3.38	1.93	0.64	0.090	0.063	0.25	0.00	3.00	2.00	11.84	0.13	3.62
LIT-10	4.63	3.16	1.47	0.68	0.090	0.063	0.24	0.00	3.00	2.00	12.47	0.12	3.59
LIT-10	3.45	2.55	0.90	0.74	0.090	0.063	0.22	0.00	3.00	2.00	13.93	0.11	3.53
LIT-10	2.34	1.90	0.44	0.81	0.090	0.063	0.19	0.00	3.00	2.00	16.11	0.09	3.44
LIT-10	1.53	1.37	0.17	0.89	0.090	0.063	0.16	0.00	3.00	2.00	18.87	0.08	3.35
LIT-10	0.95	0.95	0.00	1.00	0.090	0.063	0.13	0.00	3.00	2.00	22.59	0.07	3.25
LIT-10	5.24	2.98	2.26	0.57	0.130	0.063	0.24	0.00	3.00	2.00	12.75	0.12	4.30
LIT-10	2.40	1.76	0.64	0.73	0.130	0.063	0.18	0.00	3.00	2.00	17.09	0.09	4.10
LIT-10	1.10	0.99	0.10	0.91	0.130	0.063	0.13	0.00	3.00	2.00	22.92	0.07	3.90
LIT-10	0.86	0.81	0.05	0.94	0.130	0.063	0.12	0.00	3.00	2.00	25.08	0.06	3.85
LIT-10	0.59	0.59	0.00	0.99	0.130	0.063	0.10	0.00	3.00	2.00	28.89	0.05	3.75
LIT-10	2.55	2.20	0.35	0.86	0.005	0.042	0.28	0.00	3.00	2.00	10.53	0.14	0.87
LIT-10	1.91	1.75	0.16	0.92	0.005	0.042	0.26	0.00	3.00	2.00	11.74	0.13	0.86
LIT-10	1.43	1.38	0.05	0.97	0.005	0.042	0.23	0.00	3.00	2.00	13.09	0.11	0.84
LIT-10	0.74	0.74	0.00	1.00	0.005	0.042	0.18	0.00	3.00	2.00	16.71	0.09	0.81
LIT-10	3.54	2.92	0.62	0.83	0.010	0.042	0.28	0.00	3.00	2.00	10.60	0.14	1.23
LIT-10	2.77	2.39	0.37	0.86	0.010	0.042	0.26	0.00	3.00	2.00	11.63	0.13	1.21

Continued on next page

Table 5: Literature-Derived Performance Data for Drop-Type Inlets — Continued

ID-CODE	Q_A	Q_I	Q_O	Q_R	S_0	S_x	d_a	h_b	L_I	W_I	L_R	W_R	Fr
LIT-10	1.97	1.83	0.14	0.93	0.010	0.042	0.23	0.00	3.00	2.00	13.20	0.11	1.19
LIT-10	1.37	1.34	0.03	0.98	0.010	0.042	0.20	0.00	3.00	2.00	15.14	0.10	1.16
LIT-10	0.81	0.81	0.00	1.00	0.010	0.042	0.16	0.00	3.00	2.00	18.46	0.08	1.12
LIT-10	4.91	3.82	1.09	0.78	0.020	0.042	0.28	0.00	3.00	2.00	10.68	0.14	1.74
LIT-10	3.86	3.21	0.65	0.83	0.020	0.042	0.26	0.00	3.00	2.00	11.69	0.13	1.71
LIT-10	2.61	2.35	0.26	0.90	0.020	0.042	0.22	0.00	3.00	2.00	13.53	0.11	1.67
LIT-10	1.74	1.69	0.05	0.97	0.020	0.042	0.19	0.00	3.00	2.00	15.74	0.10	1.63
LIT-10	1.12	1.12	0.00	1.00	0.020	0.042	0.16	0.00	3.00	2.00	18.61	0.08	1.58
LIT-10	5.49	3.96	1.53	0.72	0.040	0.042	0.26	0.00	3.00	2.00	11.66	0.13	2.42
LIT-10	4.10	3.36	0.75	0.82	0.040	0.042	0.23	0.00	3.00	2.00	13.01	0.12	2.38
LIT-10	2.53	2.27	0.26	0.90	0.040	0.042	0.19	0.00	3.00	2.00	15.59	0.10	2.31
LIT-10	1.91	1.83	0.08	0.96	0.040	0.042	0.17	0.00	3.00	2.00	17.33	0.09	2.27
LIT-10	1.16	1.16	0.00	1.00	0.040	0.042	0.14	0.00	3.00	2.00	20.91	0.07	2.20
LIT-10	5.43	3.69	1.74	0.68	0.060	0.042	0.24	0.00	3.00	2.00	12.63	0.12	2.93
LIT-10	4.05	3.09	0.95	0.76	0.060	0.042	0.21	0.00	3.00	2.00	14.11	0.11	2.87
LIT-10	2.81	2.43	0.38	0.86	0.060	0.042	0.19	0.00	3.00	2.00	16.18	0.09	2.81
LIT-10	2.13	1.94	0.19	0.91	0.060	0.042	0.17	0.00	3.00	2.00	17.95	0.08	2.76
LIT-10	1.49	1.44	0.05	0.97	0.060	0.042	0.15	0.00	3.00	2.00	20.52	0.07	2.70
LIT-10	0.89	0.89	0.00	1.00	0.060	0.042	0.12	0.00	3.00	2.00	24.88	0.06	2.61
LIT-10	5.32	3.26	2.05	0.61	0.090	0.042	0.22	0.00	3.00	2.00	13.74	0.11	3.53
LIT-10	4.01	2.87	1.15	0.71	0.090	0.042	0.20	0.00	3.00	2.00	15.27	0.10	3.47
LIT-10	2.91	2.31	0.60	0.79	0.090	0.042	0.17	0.00	3.00	2.00	17.22	0.09	3.40
LIT-10	1.91	1.72	0.18	0.90	0.090	0.042	0.15	0.00	3.00	2.00	20.19	0.07	3.32
LIT-10	1.18	1.16	0.02	0.98	0.090	0.042	0.12	0.00	3.00	2.00	24.16	0.06	3.22
LIT-10	0.86	0.86	0.00	1.00	0.090	0.042	0.11	0.00	3.00	2.00	27.23	0.06	3.15
LIT-10	5.22	2.89	2.33	0.55	0.130	0.042	0.20	0.00	3.00	2.00	14.82	0.10	4.19
LIT-10	3.79	2.49	1.30	0.66	0.130	0.042	0.18	0.00	3.00	2.00	16.71	0.09	4.11
LIT-10	2.75	2.05	0.70	0.74	0.130	0.042	0.16	0.00	3.00	2.00	18.84	0.08	4.03
LIT-10	1.58	1.37	0.21	0.87	0.130	0.042	0.13	0.00	3.00	2.00	23.21	0.06	3.89
LIT-10	1.10	1.02	0.08	0.93	0.130	0.042	0.11	0.00	3.00	2.00	26.56	0.06	3.81
LIT-10	0.76	0.74	0.01	0.99	0.130	0.042	0.10	0.00	3.00	2.00	30.60	0.05	3.72
LIT-10	0.84	0.75	0.09	0.89	0.005	0.021	0.14	0.00	3.00	2.00	20.79	0.07	0.78
LIT-10	0.69	0.65	0.05	0.93	0.005	0.021	0.13	0.00	3.00	2.00	22.32	0.07	0.77
LIT-10	0.42	0.41	0.01	0.99	0.005	0.021	0.11	0.00	3.00	2.00	27.04	0.06	0.75
LIT-10	0.29	0.29	0.00	1.00	0.005	0.021	0.10	0.00	3.00	2.00	30.95	0.05	0.73
LIT-10	1.08	0.89	0.19	0.83	0.010	0.021	0.14	0.00	3.00	2.00	21.55	0.07	1.09
LIT-10	0.86	0.76	0.10	0.89	0.010	0.021	0.13	0.00	3.00	2.00	23.48	0.06	1.08
LIT-10	0.60	0.58	0.03	0.95	0.010	0.021	0.11	0.00	3.00	2.00	26.78	0.06	1.05
LIT-10	0.30	0.30	0.00	1.00	0.010	0.021	0.09	0.00	3.00	2.00	34.95	0.04	1.01

Continued on next page

Table 5: Literature-Derived Performance Data for Drop-Type Inlets — Continued

ID-CODE	Q_A	Q_I	Q_O	Q_R	S_0	S_x	d_a	h_b	L_I	W_I	L_R	W_R	Fr
LIT-10	1.64	1.30	0.34	0.79	0.020	0.021	0.14	0.00	3.00	2.00	20.97	0.07	1.55
LIT-10	1.20	1.03	0.17	0.86	0.020	0.021	0.13	0.00	3.00	2.00	23.61	0.06	1.52
LIT-10	0.89	0.81	0.08	0.91	0.020	0.021	0.11	0.00	3.00	2.00	26.37	0.06	1.50
LIT-10	0.66	0.64	0.03	0.96	0.020	0.021	0.10	0.00	3.00	2.00	29.43	0.05	1.47
LIT-10	0.40	0.40	0.00	1.00	0.020	0.021	0.08	0.00	3.00	2.00	35.76	0.04	1.42
LIT-10	2.40	1.84	0.56	0.77	0.040	0.021	0.14	0.00	3.00	2.00	20.70	0.07	2.20
LIT-10	1.60	1.32	0.28	0.83	0.040	0.021	0.12	0.00	3.00	2.00	24.10	0.06	2.15
LIT-10	1.04	0.95	0.09	0.91	0.040	0.021	0.11	0.00	3.00	2.00	28.34	0.05	2.09
LIT-10	0.58	0.58	0.01	0.99	0.040	0.021	0.09	0.00	3.00	2.00	35.19	0.04	2.01
LIT-10	0.41	0.41	0.00	1.00	0.040	0.021	0.07	0.00	3.00	2.00	40.15	0.04	1.97
LIT-10	2.90	2.17	0.72	0.75	0.060	0.021	0.14	0.00	3.00	2.00	20.81	0.07	2.69
LIT-10	1.93	1.57	0.36	0.81	0.060	0.021	0.12	0.00	3.00	2.00	24.26	0.06	2.63
LIT-10	1.25	1.13	0.12	0.90	0.060	0.021	0.11	0.00	3.00	2.00	28.52	0.05	2.55
LIT-10	0.77	0.75	0.01	0.98	0.060	0.021	0.09	0.00	3.00	2.00	34.26	0.04	2.48
LIT-10	0.45	0.45	0.00	1.00	0.060	0.021	0.07	0.00	3.00	2.00	41.94	0.04	2.40
LIT-10	3.08	2.16	0.91	0.70	0.090	0.021	0.14	0.00	3.00	2.00	21.96	0.07	3.27
LIT-10	2.30	1.84	0.46	0.80	0.090	0.021	0.12	0.00	3.00	2.00	24.51	0.06	3.21
LIT-10	1.30	1.17	0.14	0.89	0.090	0.021	0.10	0.00	3.00	2.00	30.29	0.05	3.10
LIT-10	0.76	0.75	0.02	0.98	0.090	0.021	0.08	0.00	3.00	2.00	37.02	0.04	3.00
LIT-10	0.47	0.47	0.00	1.00	0.090	0.021	0.07	0.00	3.00	2.00	44.36	0.03	2.91
LIT-10	3.48	2.19	1.29	0.63	0.130	0.021	0.13	0.00	3.00	2.00	22.46	0.07	3.91
LIT-10	2.29	1.74	0.56	0.76	0.130	0.021	0.11	0.00	3.00	2.00	26.27	0.06	3.81
LIT-10	1.45	1.26	0.19	0.87	0.130	0.021	0.10	0.00	3.00	2.00	31.20	0.05	3.71
LIT-10	0.75	0.74	0.01	0.98	0.130	0.021	0.08	0.00	3.00	2.00	39.89	0.04	3.56
LIT-10	0.36	0.36	0.00	1.00	0.130	0.021	0.06	0.00	3.00	2.00	52.48	0.03	3.40
LIT-10	4.20	2.45	1.75	0.58	0.005	0.063	0.40	0.00	1.25	2.67	3.13	0.15	0.92
LIT-10	3.07	1.96	1.10	0.64	0.005	0.063	0.35	0.00	1.25	2.67	3.53	0.13	0.90
LIT-10	2.32	1.63	0.69	0.70	0.005	0.063	0.32	0.00	1.25	2.67	3.92	0.12	0.89
LIT-10	1.31	1.10	0.22	0.84	0.005	0.063	0.26	0.00	1.25	2.67	4.85	0.10	0.86
LIT-10	0.46	0.46	0.00	1.00	0.005	0.063	0.17	0.00	1.25	2.67	7.17	0.07	0.80
LIT-10	5.60	2.76	2.83	0.49	0.010	0.063	0.39	0.00	1.25	2.67	3.20	0.15	1.30
LIT-10	3.33	2.05	1.28	0.62	0.010	0.063	0.32	0.00	1.25	2.67	3.89	0.12	1.26
LIT-10	1.78	1.36	0.42	0.76	0.010	0.063	0.25	0.00	1.25	2.67	4.93	0.10	1.21
LIT-10	0.93	0.83	0.11	0.89	0.010	0.063	0.20	0.00	1.25	2.67	6.28	0.07	1.16
LIT-10	0.42	0.42	0.00	1.00	0.010	0.063	0.15	0.00	1.25	2.67	8.49	0.06	1.10
LIT-10	5.59	2.81	2.77	0.50	0.020	0.063	0.34	0.00	1.25	2.67	3.65	0.13	1.80
LIT-10	3.32	2.11	1.21	0.64	0.020	0.063	0.28	0.00	1.25	2.67	4.44	0.11	1.74
LIT-10	1.75	1.39	0.37	0.79	0.020	0.063	0.22	0.00	1.25	2.67	5.64	0.08	1.67
LIT-10	1.22	1.08	0.14	0.88	0.020	0.063	0.19	0.00	1.25	2.67	6.46	0.07	1.63

Continued on next page

Table 5: Literature-Derived Performance Data for Drop-Type Inlets — Continued

ID-CODE	Q_A	Q_I	Q_O	Q_R	S_0	S_x	d_a	h_b	L_I	W_I	L_R	W_R	Fr
LIT-10	0.45	0.45	0.00	1.00	0.020	0.063	0.13	0.00	1.25	2.67	9.39	0.05	1.54
LIT-10	5.54	2.79	2.75	0.50	0.040	0.063	0.30	0.00	1.25	2.67	4.17	0.11	2.48
LIT-10	3.44	2.10	1.34	0.61	0.040	0.063	0.25	0.00	1.25	2.67	4.99	0.09	2.41
LIT-10	2.91	1.95	0.96	0.67	0.040	0.063	0.24	0.00	1.25	2.67	5.31	0.09	2.39
LIT-10	1.84	1.39	0.45	0.76	0.040	0.063	0.20	0.00	1.25	2.67	6.31	0.07	2.32
LIT-10	0.90	0.85	0.06	0.94	0.040	0.063	0.15	0.00	1.25	2.67	8.23	0.06	2.22
LIT-10	0.48	0.48	0.00	1.00	0.040	0.063	0.12	0.00	1.25	2.67	10.46	0.04	2.13
LIT-10	5.49	2.50	2.99	0.46	0.060	0.063	0.28	0.00	1.25	2.67	4.52	0.10	3.00
LIT-10	3.04	1.95	1.09	0.64	0.060	0.063	0.22	0.00	1.25	2.67	5.64	0.08	2.89
LIT-10	2.06	1.55	0.51	0.75	0.060	0.063	0.19	0.00	1.25	2.67	6.52	0.07	2.82
LIT-10	0.95	0.89	0.06	0.94	0.060	0.063	0.14	0.00	1.25	2.67	8.73	0.05	2.69
LIT-10	0.50	0.50	0.00	1.00	0.060	0.063	0.11	0.00	1.25	2.67	11.06	0.04	2.59
LIT-10	5.31	1.97	3.35	0.37	0.130	0.063	0.24	0.00	1.25	2.67	5.29	0.09	4.30
LIT-10	3.98	1.77	2.21	0.44	0.130	0.063	0.21	0.00	1.25	2.67	5.89	0.08	4.23
LIT-10	2.53	1.51	1.02	0.60	0.130	0.063	0.18	0.00	1.25	2.67	6.98	0.07	4.11
LIT-10	1.41	1.15	0.26	0.81	0.130	0.063	0.14	0.00	1.25	2.67	8.70	0.05	3.96
LIT-10	0.45	0.45	0.00	1.00	0.130	0.063	0.09	0.00	1.25	2.67	13.29	0.04	3.69
LIT-10	2.07	1.27	0.80	0.61	0.005	0.042	0.26	0.00	1.25	2.67	4.74	0.10	0.86
LIT-10	1.56	1.02	0.54	0.66	0.005	0.042	0.24	0.00	1.25	2.67	5.28	0.09	0.84
LIT-10	1.13	0.83	0.30	0.73	0.005	0.042	0.21	0.00	1.25	2.67	5.95	0.08	0.83
LIT-10	0.86	0.68	0.17	0.80	0.005	0.042	0.19	0.00	1.25	2.67	6.60	0.07	0.81
LIT-10	0.24	0.24	0.00	1.00	0.005	0.042	0.12	0.00	1.25	2.67	10.60	0.04	0.75
LIT-10	3.00	1.60	1.39	0.53	0.010	0.042	0.27	0.00	1.25	2.67	4.70	0.10	1.22
LIT-10	2.09	1.27	0.81	0.61	0.010	0.042	0.23	0.00	1.25	2.67	5.38	0.09	1.19
LIT-10	1.21	0.87	0.33	0.72	0.010	0.042	0.19	0.00	1.25	2.67	6.62	0.07	1.15
LIT-10	0.91	0.70	0.20	0.77	0.010	0.042	0.17	0.00	1.25	2.67	7.37	0.06	1.13
LIT-10	0.24	0.24	0.00	1.00	0.010	0.042	0.10	0.00	1.25	2.67	12.19	0.04	1.04
LIT-10	4.14	2.04	2.09	0.49	0.020	0.042	0.26	0.00	1.25	2.67	4.74	0.10	1.72
LIT-10	2.16	1.34	0.82	0.62	0.020	0.042	0.21	0.00	1.25	2.67	6.06	0.08	1.65
LIT-10	1.28	0.88	0.39	0.69	0.020	0.042	0.17	0.00	1.25	2.67	7.38	0.06	1.60
LIT-10	0.65	0.55	0.10	0.85	0.020	0.042	0.13	0.00	1.25	2.67	9.51	0.05	1.53
LIT-10	0.20	0.20	0.00	1.00	0.020	0.042	0.09	0.00	1.25	2.67	14.70	0.03	1.42
LIT-10	5.54	2.34	3.20	0.42	0.040	0.042	0.26	0.00	1.25	2.67	4.84	0.10	2.42
LIT-10	2.97	1.70	1.27	0.57	0.040	0.042	0.20	0.00	1.25	2.67	6.12	0.08	2.33
LIT-10	1.79	1.21	0.58	0.68	0.040	0.042	0.17	0.00	1.25	2.67	7.40	0.06	2.26
LIT-10	0.79	0.66	0.13	0.84	0.040	0.042	0.12	0.00	1.25	2.67	10.04	0.05	2.15
LIT-10	0.24	0.24	0.00	1.00	0.040	0.042	0.08	0.00	1.25	2.67	15.69	0.03	2.00
LIT-10	5.49	2.18	3.31	0.40	0.060	0.042	0.24	0.00	1.25	2.67	5.24	0.09	2.93
LIT-10	3.28	1.70	1.58	0.52	0.060	0.042	0.20	0.00	1.25	2.67	6.36	0.07	2.83

Continued on next page

Table 5: Literature-Derived Performance Data for Drop-Type Inlets — Continued

ID-CODE	Q_A	Q_I	Q_O	Q_R	S_0	S_x	d_a	h_b	L_I	W_I	L_R	W_R	Fr
LIT-10	1.83	1.25	0.58	0.68	0.060	0.042	0.16	0.00	1.25	2.67	7.91	0.06	2.73
LIT-10	1.55	1.12	0.43	0.72	0.060	0.042	0.15	0.00	1.25	2.67	8.43	0.06	2.71
LIT-10	0.70	0.59	0.12	0.83	0.060	0.042	0.11	0.00	1.25	2.67	11.33	0.04	2.58
LIT-10	0.27	0.27	0.00	1.00	0.060	0.042	0.08	0.00	1.25	2.67	16.16	0.03	2.43
LIT-10	5.40	2.01	3.39	0.37	0.090	0.042	0.22	0.00	1.25	2.67	5.69	0.08	3.54
LIT-10	3.35	1.61	1.73	0.48	0.090	0.042	0.18	0.00	1.25	2.67	6.81	0.07	3.43
LIT-10	2.43	1.46	0.97	0.60	0.090	0.042	0.16	0.00	1.25	2.67	7.68	0.06	3.37
LIT-10	1.83	1.25	0.58	0.68	0.090	0.042	0.15	0.00	1.25	2.67	8.54	0.05	3.31
LIT-10	0.87	0.75	0.13	0.86	0.090	0.042	0.11	0.00	1.25	2.67	11.27	0.04	3.16
LIT-10	0.33	0.33	0.00	1.00	0.090	0.042	0.08	0.00	1.25	2.67	16.22	0.03	2.97
LIT-10	5.27	1.75	3.52	0.33	0.130	0.042	0.20	0.00	1.25	2.67	6.15	0.08	4.20
LIT-10	2.82	1.41	1.41	0.50	0.130	0.042	0.16	0.00	1.25	2.67	7.78	0.06	4.04
LIT-10	2.00	1.28	0.72	0.64	0.130	0.042	0.14	0.00	1.25	2.67	8.85	0.05	3.95
LIT-10	0.94	0.79	0.15	0.84	0.130	0.042	0.11	0.00	1.25	2.67	11.76	0.04	3.77
LIT-10	0.27	0.27	0.00	1.00	0.130	0.042	0.07	0.00	1.25	2.67	18.82	0.02	3.48
LIT-10	0.41	0.31	0.10	0.76	0.005	0.021	0.11	0.00	1.25	2.67	11.37	0.04	0.74
LIT-10	0.23	0.20	0.03	0.87	0.005	0.021	0.09	0.00	1.25	2.67	14.13	0.03	0.72
LIT-10	0.15	0.14	0.01	0.95	0.005	0.021	0.08	0.00	1.25	2.67	16.56	0.03	0.70
LIT-10	0.05	0.05	0.00	1.00	0.005	0.021	0.05	0.00	1.25	2.67	24.26	0.02	0.65
LIT-10	0.98	0.55	0.43	0.57	0.010	0.021	0.13	0.00	1.25	2.67	9.31	0.05	1.09
LIT-10	0.52	0.36	0.16	0.69	0.010	0.021	0.11	0.00	1.25	2.67	11.84	0.04	1.04
LIT-10	0.43	0.31	0.11	0.73	0.010	0.021	0.10	0.00	1.25	2.67	12.72	0.04	1.03
LIT-10	0.08	0.08	0.00	1.00	0.010	0.021	0.05	0.00	1.25	2.67	23.38	0.02	0.93
LIT-10	1.35	0.69	0.66	0.51	0.020	0.021	0.13	0.00	1.25	2.67	9.40	0.05	1.53
LIT-10	0.71	0.44	0.27	0.61	0.020	0.021	0.10	0.00	1.25	2.67	11.93	0.04	1.47
LIT-10	0.52	0.36	0.16	0.69	0.020	0.021	0.09	0.00	1.25	2.67	13.41	0.03	1.44
LIT-10	0.23	0.21	0.02	0.92	0.020	0.021	0.07	0.00	1.25	2.67	18.36	0.03	1.38
LIT-10	0.20	0.20	0.00	1.00	0.020	0.021	0.07	0.00	1.25	2.67	19.15	0.02	1.37
LIT-10	2.28	1.05	1.23	0.46	0.040	0.021	0.14	0.00	1.25	2.67	8.80	0.05	2.19
LIT-10	1.32	0.71	0.61	0.54	0.040	0.021	0.12	0.00	1.25	2.67	10.81	0.04	2.12
LIT-10	0.79	0.49	0.30	0.62	0.040	0.021	0.10	0.00	1.25	2.67	13.11	0.04	2.05
LIT-10	0.54	0.39	0.15	0.72	0.040	0.021	0.08	0.00	1.25	2.67	15.08	0.03	2.01
LIT-10	0.08	0.08	0.00	1.00	0.040	0.021	0.04	0.00	1.25	2.67	30.65	0.02	1.78
LIT-10	2.59	1.15	1.45	0.44	0.060	0.021	0.14	0.00	1.25	2.67	9.04	0.05	2.67
LIT-10	1.51	0.81	0.70	0.54	0.060	0.021	0.11	0.00	1.25	2.67	11.07	0.04	2.59
LIT-10	0.90	0.55	0.35	0.61	0.060	0.021	0.09	0.00	1.25	2.67	13.44	0.03	2.50
LIT-10	0.56	0.40	0.15	0.72	0.060	0.021	0.08	0.00	1.25	2.67	16.07	0.03	2.43
LIT-10	0.09	0.09	0.00	1.00	0.060	0.021	0.04	0.00	1.25	2.67	31.38	0.01	2.17
LIT-10	2.74	1.21	1.53	0.44	0.090	0.021	0.13	0.00	1.25	2.67	9.55	0.05	3.25

Continued on next page

Table 5: Literature-Derived Performance Data for Drop-Type Inlets — Continued

ID-CODE	Q_A	Q_I	Q_O	Q_R	S_0	S_x	d_a	h_b	L_I	W_I	L_R	W_R	Fr
LIT-10	1.66	0.88	0.79	0.53	0.090	0.021	0.11	0.00	1.25	2.67	11.52	0.04	3.15
LIT-10	1.17	0.68	0.49	0.58	0.090	0.021	0.10	0.00	1.25	2.67	13.15	0.04	3.08
LIT-10	0.59	0.43	0.17	0.72	0.090	0.021	0.07	0.00	1.25	2.67	16.96	0.03	2.95
LIT-10	0.06	0.06	0.00	1.00	0.090	0.021	0.03	0.00	1.25	2.67	39.99	0.01	2.57
LIT-10	2.86	1.18	1.68	0.41	0.130	0.021	0.12	0.00	1.25	2.67	10.08	0.05	3.87
LIT-10	1.79	0.93	0.86	0.52	0.130	0.021	0.10	0.00	1.25	2.67	12.02	0.04	3.75
LIT-10	1.07	0.66	0.42	0.61	0.130	0.021	0.09	0.00	1.25	2.67	14.55	0.03	3.64
LIT-10	0.54	0.39	0.15	0.72	0.130	0.021	0.07	0.00	1.25	2.67	18.76	0.02	3.48
LIT-10	0.07	0.07	0.00	1.00	0.130	0.021	0.03	0.00	1.25	2.67	40.64	0.01	3.05
LIT-10	4.95	2.39	2.56	0.48	0.005	0.063	0.42	0.00	1.25	2.00	2.95	0.21	0.93
LIT-10	2.94	1.74	1.20	0.59	0.005	0.063	0.35	0.00	1.25	2.00	3.58	0.17	0.90
LIT-10	1.41	1.06	0.36	0.75	0.005	0.063	0.26	0.00	1.25	2.00	4.72	0.13	0.86
LIT-10	0.73	0.65	0.08	0.88	0.005	0.063	0.21	0.00	1.25	2.00	6.03	0.10	0.83
LIT-10	0.18	0.18	0.00	1.00	0.005	0.063	0.12	0.00	1.25	2.00	10.31	0.06	0.76
LIT-10	5.57	2.52	3.05	0.45	0.010	0.063	0.39	0.00	1.25	2.00	3.21	0.19	1.30
LIT-10	2.94	1.74	1.20	0.59	0.010	0.063	0.31	0.00	1.25	2.00	4.08	0.15	1.25
LIT-10	1.82	1.28	0.54	0.70	0.010	0.063	0.26	0.00	1.25	2.00	4.88	0.13	1.21
LIT-10	0.89	0.75	0.14	0.84	0.010	0.063	0.20	0.00	1.25	2.00	6.39	0.10	1.16
LIT-10	0.21	0.21	0.00	1.00	0.010	0.063	0.11	0.00	1.25	2.00	11.00	0.06	1.06
LIT-10	5.55	2.56	2.99	0.46	0.020	0.063	0.34	0.00	1.25	2.00	3.66	0.17	1.79
LIT-10	3.41	1.96	1.44	0.58	0.020	0.063	0.28	0.00	1.25	2.00	4.40	0.14	1.74
LIT-10	1.83	1.31	0.51	0.72	0.020	0.063	0.22	0.00	1.25	2.00	5.56	0.11	1.67
LIT-10	0.85	0.76	0.10	0.88	0.020	0.063	0.17	0.00	1.25	2.00	7.39	0.08	1.60
LIT-10	0.28	0.28	0.00	1.00	0.020	0.063	0.11	0.00	1.25	2.00	11.24	0.06	1.49
LIT-10	5.49	2.49	3.00	0.45	0.040	0.063	0.30	0.00	1.25	2.00	4.19	0.15	2.48
LIT-10	3.41	1.90	1.51	0.56	0.040	0.063	0.25	0.00	1.25	2.00	5.00	0.12	2.41
LIT-10	1.71	1.30	0.42	0.76	0.040	0.063	0.19	0.00	1.25	2.00	6.48	0.10	2.31
LIT-10	0.79	0.72	0.07	0.91	0.040	0.063	0.14	0.00	1.25	2.00	8.66	0.07	2.20
LIT-10	0.26	0.26	0.00	1.00	0.040	0.063	0.09	0.00	1.25	2.00	13.19	0.05	2.05
LIT-10	5.45	2.23	3.21	0.41	0.060	0.063	0.28	0.00	1.25	2.00	4.53	0.14	3.00
LIT-10	3.02	1.71	1.31	0.57	0.060	0.063	0.22	0.00	1.25	2.00	5.65	0.11	2.89
LIT-10	1.98	1.36	0.62	0.69	0.060	0.063	0.19	0.00	1.25	2.00	6.62	0.09	2.82
LIT-10	0.86	0.79	0.07	0.92	0.060	0.063	0.14	0.00	1.25	2.00	9.05	0.07	2.67
LIT-10	0.37	0.37	0.00	1.00	0.060	0.063	0.10	0.00	1.25	2.00	12.48	0.05	2.54
LIT-10	5.36	1.92	3.44	0.36	0.090	0.063	0.25	0.00	1.25	2.00	4.92	0.13	3.62
LIT-10	3.80	1.82	1.98	0.48	0.090	0.063	0.22	0.00	1.25	2.00	5.60	0.11	3.55
LIT-10	2.00	1.31	0.69	0.65	0.090	0.063	0.18	0.00	1.25	2.00	7.12	0.09	3.41
LIT-10	0.96	0.86	0.10	0.90	0.090	0.063	0.13	0.00	1.25	2.00	9.37	0.07	3.26
LIT-10	0.31	0.31	0.00	1.00	0.090	0.063	0.09	0.00	1.25	2.00	14.34	0.04	3.03

Continued on next page

Table 5: Literature-Derived Performance Data for Drop-Type Inlets — Continued

ID-CODE	Q_A	Q_I	Q_O	Q_R	S_0	S_x	d_a	h_b	L_I	W_I	L_R	W_R	Fr
LIT-10	5.25	1.69	3.56	0.32	0.130	0.063	0.24	0.00	1.25	2.00	5.31	0.12	4.30
LIT-10	3.11	1.42	1.69	0.46	0.130	0.063	0.19	0.00	1.25	2.00	6.47	0.10	4.16
LIT-10	2.04	1.22	0.81	0.60	0.130	0.063	0.17	0.00	1.25	2.00	7.58	0.08	4.05
LIT-10	1.02	0.87	0.15	0.85	0.130	0.063	0.13	0.00	1.25	2.00	9.83	0.06	3.88
LIT-10	0.25	0.25	0.00	1.00	0.130	0.063	0.08	0.00	1.25	2.00	16.63	0.04	3.56
LIT-10	2.49	1.31	1.17	0.53	0.005	0.042	0.28	0.00	1.25	2.00	4.43	0.14	0.87
LIT-10	1.39	0.88	0.51	0.63	0.005	0.042	0.23	0.00	1.25	2.00	5.51	0.11	0.84
LIT-10	0.86	0.63	0.24	0.72	0.005	0.042	0.19	0.00	1.25	2.00	6.58	0.09	0.81
LIT-10	0.33	0.31	0.02	0.94	0.005	0.042	0.13	0.00	1.25	2.00	9.46	0.07	0.77
LIT-10	0.11	0.11	0.00	1.00	0.005	0.042	0.09	0.00	1.25	2.00	14.29	0.04	0.71
LIT-10	2.42	1.30	1.12	0.54	0.010	0.042	0.25	0.00	1.25	2.00	5.10	0.12	1.20
LIT-10	1.54	0.95	0.59	0.62	0.010	0.042	0.21	0.00	1.25	2.00	6.03	0.10	1.17
LIT-10	0.92	0.67	0.25	0.73	0.010	0.042	0.17	0.00	1.25	2.00	7.33	0.09	1.13
LIT-10	0.30	0.28	0.01	0.95	0.010	0.042	0.11	0.00	1.25	2.00	11.22	0.06	1.06
LIT-10	0.09	0.09	0.00	1.00	0.010	0.042	0.07	0.00	1.25	2.00	17.65	0.04	0.98
LIT-10	4.16	1.90	2.25	0.46	0.020	0.042	0.26	0.00	1.25	2.00	4.74	0.13	1.72
LIT-10	2.11	1.23	0.88	0.58	0.020	0.042	0.20	0.00	1.25	2.00	6.11	0.10	1.65
LIT-10	0.93	0.68	0.25	0.74	0.020	0.042	0.15	0.00	1.25	2.00	8.30	0.08	1.57
LIT-10	0.44	0.40	0.03	0.92	0.020	0.042	0.11	0.00	1.25	2.00	11.02	0.06	1.49
LIT-10	0.12	0.12	0.00	1.00	0.020	0.042	0.07	0.00	1.25	2.00	18.18	0.03	1.37
LIT-10	5.47	2.06	3.41	0.38	0.040	0.042	0.26	0.00	1.25	2.00	4.86	0.13	2.42
LIT-10	2.92	1.53	1.38	0.53	0.040	0.042	0.20	0.00	1.25	2.00	6.16	0.10	2.33
LIT-10	1.77	1.12	0.64	0.64	0.040	0.042	0.17	0.00	1.25	2.00	7.43	0.08	2.26
LIT-10	0.42	0.39	0.03	0.92	0.040	0.042	0.10	0.00	1.25	2.00	12.74	0.05	2.06
LIT-10	0.15	0.15	0.00	1.00	0.040	0.042	0.07	0.00	1.25	2.00	18.83	0.03	1.94
LIT-10	5.44	1.96	3.48	0.36	0.060	0.042	0.24	0.00	1.25	2.00	5.26	0.12	2.93
LIT-10	2.77	1.47	1.30	0.53	0.060	0.042	0.18	0.00	1.25	2.00	6.78	0.09	2.81
LIT-10	1.52	1.01	0.52	0.66	0.060	0.042	0.15	0.00	1.25	2.00	8.48	0.07	2.70
LIT-10	0.70	0.59	0.11	0.84	0.060	0.042	0.11	0.00	1.25	2.00	11.37	0.05	2.57
LIT-10	0.16	0.16	0.00	1.00	0.060	0.042	0.06	0.00	1.25	2.00	19.72	0.03	2.35
LIT-10	5.29	1.75	3.54	0.33	0.090	0.042	0.22	0.00	1.25	2.00	5.74	0.11	3.53
LIT-10	3.17	1.45	1.72	0.46	0.090	0.042	0.18	0.00	1.25	2.00	6.95	0.09	3.42
LIT-10	1.76	1.10	0.66	0.62	0.090	0.042	0.14	0.00	1.25	2.00	8.66	0.07	3.30
LIT-10	0.80	0.65	0.15	0.81	0.090	0.042	0.11	0.00	1.25	2.00	11.67	0.05	3.14
LIT-10	0.18	0.18	0.00	1.00	0.090	0.042	0.06	0.00	1.25	2.00	20.44	0.03	2.86
LIT-10	5.26	1.61	3.64	0.31	0.130	0.042	0.20	0.00	1.25	2.00	6.16	0.10	4.20
LIT-10	3.13	1.30	1.83	0.42	0.130	0.042	0.17	0.00	1.25	2.00	7.48	0.08	4.06
LIT-10	1.86	1.06	0.80	0.57	0.130	0.042	0.14	0.00	1.25	2.00	9.09	0.07	3.93
LIT-10	0.77	0.65	0.13	0.84	0.130	0.042	0.10	0.00	1.25	2.00	12.64	0.05	3.72

Continued on next page

Table 5: Literature-Derived Performance Data for Drop-Type Inlets — Continued

ID-CODE	Q_A	Q_I	Q_O	Q_R	S_0	S_x	d_a	h_b	L_I	W_I	L_R	W_R	Fr
LIT-10	0.14	0.14	0.00	1.00	0.130	0.042	0.05	0.00	1.25	2.00	24.32	0.03	3.34
LIT-10	0.69	0.38	0.31	0.55	0.005	0.021	0.13	0.00	1.25	2.00	9.33	0.07	0.77
LIT-10	0.57	0.34	0.22	0.60	0.005	0.021	0.12	0.00	1.25	2.00	10.03	0.06	0.76
LIT-10	0.43	0.29	0.14	0.67	0.005	0.021	0.11	0.00	1.25	2.00	11.12	0.06	0.75
LIT-10	0.25	0.20	0.05	0.81	0.005	0.021	0.09	0.00	1.25	2.00	13.65	0.05	0.72
LIT-10	0.09	0.09	0.00	0.97	0.005	0.021	0.06	0.00	1.25	2.00	19.74	0.03	0.68
LIT-10	1.01	0.50	0.51	0.49	0.010	0.021	0.14	0.00	1.25	2.00	9.20	0.07	1.09
LIT-10	0.48	0.29	0.19	0.60	0.010	0.021	0.10	0.00	1.25	2.00	12.13	0.05	1.04
LIT-10	0.35	0.25	0.10	0.72	0.010	0.021	0.09	0.00	1.25	2.00	13.68	0.05	1.02
LIT-10	0.19	0.17	0.02	0.87	0.010	0.021	0.07	0.00	1.25	2.00	17.15	0.04	0.98
LIT-10	0.03	0.03	0.00	1.00	0.010	0.021	0.04	0.00	1.25	2.00	35.46	0.02	0.86
LIT-10	1.58	0.73	0.84	0.47	0.020	0.021	0.14	0.00	1.25	2.00	8.87	0.07	1.55
LIT-10	0.85	0.46	0.38	0.55	0.020	0.021	0.11	0.00	1.25	2.00	11.19	0.06	1.49
LIT-10	0.49	0.31	0.18	0.63	0.020	0.021	0.09	0.00	1.25	2.00	13.69	0.05	1.44
LIT-10	0.23	0.19	0.04	0.81	0.020	0.021	0.07	0.00	1.25	2.00	18.18	0.03	1.38
LIT-10	0.05	0.05	0.00	0.98	0.020	0.021	0.04	0.00	1.25	2.00	32.69	0.02	1.24
LIT-10	1.88	0.86	1.02	0.46	0.040	0.021	0.13	0.00	1.25	2.00	9.45	0.07	2.17
LIT-10	1.11	0.62	0.49	0.56	0.040	0.021	0.11	0.00	1.25	2.00	11.51	0.05	2.10
LIT-10	0.51	0.36	0.15	0.71	0.040	0.021	0.08	0.00	1.25	2.00	15.47	0.04	2.00
LIT-10	0.19	0.17	0.02	0.89	0.040	0.021	0.06	0.00	1.25	2.00	22.37	0.03	1.88
LIT-10	0.04	0.04	0.00	1.00	0.040	0.021	0.03	0.00	1.25	2.00	40.36	0.02	1.70
LIT-10	2.37	1.00	1.37	0.42	0.060	0.021	0.13	0.00	1.25	2.00	9.35	0.07	2.66
LIT-10	1.22	0.65	0.57	0.53	0.060	0.021	0.10	0.00	1.25	2.00	12.00	0.05	2.55
LIT-10	0.68	0.42	0.26	0.62	0.060	0.021	0.08	0.00	1.25	2.00	14.91	0.04	2.46
LIT-10	0.35	0.27	0.08	0.78	0.060	0.021	0.07	0.00	1.25	2.00	19.19	0.03	2.35
LIT-10	0.05	0.05	0.00	1.00	0.060	0.021	0.03	0.00	1.25	2.00	39.31	0.02	2.09
LIT-10	2.49	1.02	1.47	0.41	0.090	0.021	0.13	0.00	1.25	2.00	9.90	0.06	3.23
LIT-10	1.30	0.65	0.64	0.50	0.090	0.021	0.10	0.00	1.25	2.00	12.65	0.05	3.10
LIT-10	0.73	0.45	0.28	0.61	0.090	0.021	0.08	0.00	1.25	2.00	15.69	0.04	2.99
LIT-10	0.36	0.27	0.08	0.76	0.090	0.021	0.06	0.00	1.25	2.00	20.50	0.03	2.86
LIT-10	0.05	0.05	0.00	1.00	0.090	0.021	0.03	0.00	1.25	2.00	43.40	0.01	2.54
LIT-10	3.11	1.04	2.07	0.33	0.130	0.021	0.13	0.00	1.25	2.00	9.76	0.06	3.89
LIT-10	1.11	0.62	0.49	0.55	0.130	0.021	0.09	0.00	1.25	2.00	14.36	0.04	3.64
LIT-10	0.73	0.45	0.28	0.62	0.130	0.021	0.07	0.00	1.25	2.00	16.83	0.04	3.55
LIT-10	0.23	0.19	0.03	0.86	0.130	0.021	0.05	0.00	1.25	2.00	26.08	0.02	3.30
LIT-10	0.02	0.02	0.00	1.00	0.130	0.021	0.02	0.00	1.25	2.00	60.29	0.01	2.89
LIT-11	4.56	4.18	0.38	0.92	0.005	0.063	0.41	0.00	3.00	4.00	7.30	0.10	0.93
LIT-11	3.40	3.26	0.15	0.96	0.005	0.063	0.37	0.00	3.00	4.00	8.14	0.09	0.91
LIT-11	2.77	2.73	0.04	0.98	0.005	0.063	0.34	0.00	3.00	4.00	8.79	0.09	0.90

Continued on next page

Table 5: Literature-Derived Performance Data for Drop-Type Inlets — Continued

ID-CODE	Q_A	Q_I	Q_O	Q_R	S_0	S_x	d_a	h_b	L_I	W_I	L_R	W_R	Fr
LIT-11	2.10	2.10	0.00	1.00	0.005	0.063	0.31	0.00	3.00	4.00	9.76	0.08	0.88
LIT-11	5.51	4.97	0.54	0.90	0.010	0.063	0.39	0.00	3.00	4.00	7.74	0.10	1.30
LIT-11	4.16	3.92	0.25	0.94	0.010	0.063	0.35	0.00	3.00	4.00	8.60	0.09	1.27
LIT-11	3.32	3.23	0.10	0.97	0.010	0.063	0.32	0.00	3.00	4.00	9.35	0.08	1.26
LIT-11	2.62	2.60	0.02	0.99	0.010	0.063	0.29	0.00	3.00	4.00	10.23	0.07	1.24
LIT-11	2.10	2.10	0.00	1.00	0.010	0.063	0.27	0.00	3.00	4.00	11.11	0.07	1.22
LIT-11	5.55	5.11	0.44	0.92	0.020	0.063	0.34	0.00	3.00	4.00	8.79	0.09	1.79
LIT-11	4.28	4.10	0.18	0.96	0.020	0.063	0.31	0.00	3.00	4.00	9.69	0.08	1.77
LIT-11	3.41	3.34	0.08	0.98	0.020	0.063	0.28	0.00	3.00	4.00	10.54	0.07	1.74
LIT-11	2.54	2.54	0.00	1.00	0.020	0.063	0.25	0.00	3.00	4.00	11.78	0.06	1.71
LIT-11	5.51	5.18	0.33	0.94	0.040	0.063	0.30	0.00	3.00	4.00	10.04	0.07	2.48
LIT-11	3.86	3.80	0.06	0.99	0.040	0.063	0.26	0.00	3.00	4.00	11.47	0.07	2.43
LIT-11	3.28	3.27	0.01	1.00	0.040	0.063	0.25	0.00	3.00	4.00	12.19	0.06	2.40
LIT-11	2.71	2.71	0.00	1.00	0.040	0.063	0.23	0.00	3.00	4.00	13.10	0.06	2.38
LIT-11	5.45	5.15	0.29	0.95	0.060	0.063	0.28	0.00	3.00	4.00	10.87	0.07	3.00
LIT-11	4.66	4.55	0.10	0.98	0.060	0.063	0.26	0.00	3.00	4.00	11.53	0.07	2.97
LIT-11	4.04	4.00	0.04	0.99	0.060	0.063	0.25	0.00	3.00	4.00	12.16	0.06	2.94
LIT-11	2.99	2.99	0.00	1.00	0.060	0.063	0.22	0.00	3.00	4.00	13.61	0.06	2.89
LIT-11	5.38	5.17	0.21	0.96	0.090	0.063	0.25	0.00	3.00	4.00	11.79	0.06	3.63
LIT-11	4.58	4.47	0.12	0.97	0.090	0.063	0.24	0.00	3.00	4.00	12.52	0.06	3.59
LIT-11	4.04	4.00	0.04	0.99	0.090	0.063	0.23	0.00	3.00	4.00	13.12	0.06	3.56
LIT-11	3.21	3.21	0.00	1.00	0.090	0.063	0.21	0.00	3.00	4.00	14.30	0.05	3.51
LIT-11	5.26	5.07	0.20	0.96	0.130	0.063	0.24	0.00	3.00	4.00	12.73	0.06	4.30
LIT-11	4.61	4.50	0.11	0.98	0.130	0.063	0.22	0.00	3.00	4.00	13.38	0.06	4.27
LIT-11	4.11	4.07	0.05	0.99	0.130	0.063	0.21	0.00	3.00	4.00	13.96	0.05	4.24
LIT-11	3.44	3.42	0.02	0.99	0.130	0.063	0.20	0.00	3.00	4.00	14.94	0.05	4.19
LIT-11	2.81	2.81	0.00	1.00	0.130	0.063	0.19	0.00	3.00	4.00	16.11	0.05	4.14
LIT-11	2.51	2.31	0.21	0.92	0.005	0.042	0.28	0.00	3.00	4.00	10.58	0.07	0.87
LIT-11	2.11	1.99	0.12	0.94	0.005	0.042	0.27	0.00	3.00	4.00	11.30	0.07	0.86
LIT-11	1.71	1.66	0.05	0.97	0.005	0.042	0.25	0.00	3.00	4.00	12.23	0.06	0.85
LIT-11	1.18	1.17	0.00	1.00	0.005	0.042	0.21	0.00	3.00	4.00	14.06	0.05	0.83
LIT-11	3.53	3.06	0.48	0.87	0.010	0.042	0.28	0.00	3.00	4.00	10.61	0.07	1.23
LIT-11	2.83	2.56	0.28	0.90	0.010	0.042	0.26	0.00	3.00	4.00	11.53	0.07	1.21
LIT-11	2.17	2.05	0.11	0.95	0.010	0.042	0.24	0.00	3.00	4.00	12.75	0.06	1.19
LIT-11	1.70	1.66	0.03	0.98	0.010	0.042	0.21	0.00	3.00	4.00	13.97	0.05	1.18
LIT-11	1.17	1.17	0.00	1.00	0.010	0.042	0.19	0.00	3.00	4.00	16.03	0.05	1.15
LIT-11	4.88	4.05	0.83	0.83	0.020	0.042	0.28	0.00	3.00	4.00	10.70	0.07	1.74
LIT-11	3.33	2.97	0.36	0.89	0.020	0.042	0.24	0.00	3.00	4.00	12.35	0.06	1.70
LIT-11	2.23	2.13	0.10	0.96	0.020	0.042	0.21	0.00	3.00	4.00	14.36	0.05	1.65

Continued on next page

Table 5: Literature-Derived Performance Data for Drop-Type Inlets — Continued

ID-CODE	Q_A	Q_I	Q_O	Q_R	S_0	S_x	d_a	h_b	L_I	W_I	L_R	W_R	Fr
LIT-11	1.24	1.24	0.00	1.00	0.020	0.042	0.17	0.00	3.00	4.00	17.87	0.04	1.59
LIT-11	5.51	4.63	0.88	0.84	0.040	0.042	0.26	0.00	3.00	4.00	11.65	0.06	2.42
LIT-11	4.11	3.67	0.44	0.89	0.040	0.042	0.23	0.00	3.00	4.00	13.00	0.06	2.38
LIT-11	3.05	2.86	0.18	0.94	0.040	0.042	0.21	0.00	3.00	4.00	14.54	0.05	2.33
LIT-11	2.07	2.04	0.03	0.99	0.040	0.042	0.18	0.00	3.00	4.00	16.82	0.04	2.28
LIT-11	1.62	1.62	0.00	1.00	0.040	0.042	0.16	0.00	3.00	4.00	18.44	0.04	2.24
LIT-11	5.44	4.69	0.75	0.86	0.060	0.042	0.24	0.00	3.00	4.00	12.62	0.06	2.93
LIT-11	3.94	3.58	0.36	0.91	0.060	0.042	0.21	0.00	3.00	4.00	14.26	0.05	2.87
LIT-11	2.76	2.65	0.10	0.96	0.060	0.042	0.18	0.00	3.00	4.00	16.29	0.05	2.81
LIT-11	1.48	1.48	0.00	1.00	0.060	0.042	0.15	0.00	3.00	4.00	20.55	0.04	2.70
LIT-11	1.26	1.26	0.00	1.00	0.060	0.042	0.14	0.00	3.00	4.00	21.86	0.03	2.67
LIT-11	5.38	4.77	0.61	0.89	0.090	0.042	0.22	0.00	3.00	4.00	13.68	0.05	3.54
LIT-11	4.24	3.86	0.38	0.91	0.090	0.042	0.20	0.00	3.00	4.00	14.96	0.05	3.48
LIT-11	2.97	2.85	0.13	0.96	0.090	0.042	0.18	0.00	3.00	4.00	17.09	0.04	3.41
LIT-11	1.48	1.48	0.00	1.00	0.090	0.042	0.14	0.00	3.00	4.00	22.20	0.03	3.26
LIT-11	1.21	1.21	0.00	1.00	0.090	0.042	0.13	0.00	3.00	4.00	23.92	0.03	3.22
LIT-11	5.25	4.68	0.57	0.89	0.130	0.042	0.20	0.00	3.00	4.00	14.79	0.05	4.20
LIT-11	3.23	3.10	0.13	0.96	0.130	0.042	0.17	0.00	3.00	4.00	17.74	0.04	4.07
LIT-11	2.37	2.34	0.03	0.99	0.130	0.042	0.15	0.00	3.00	4.00	19.93	0.04	3.99
LIT-11	1.21	1.21	0.00	1.00	0.130	0.042	0.12	0.00	3.00	4.00	25.61	0.03	3.83
LIT-11	0.83	0.78	0.05	0.94	0.005	0.021	0.14	0.00	3.00	4.00	20.92	0.04	0.78
LIT-11	0.69	0.67	0.02	0.96	0.005	0.021	0.13	0.00	3.00	4.00	22.35	0.03	0.77
LIT-11	0.44	0.44	0.00	0.99	0.005	0.021	0.11	0.00	3.00	4.00	26.41	0.03	0.75
LIT-11	0.40	0.40	0.00	1.00	0.005	0.021	0.11	0.00	3.00	4.00	27.39	0.03	0.74
LIT-11	1.19	1.04	0.15	0.88	0.010	0.021	0.14	0.00	3.00	4.00	20.78	0.04	1.10
LIT-11	0.94	0.86	0.08	0.91	0.010	0.021	0.13	0.00	3.00	4.00	22.65	0.03	1.08
LIT-11	0.68	0.65	0.03	0.96	0.010	0.021	0.12	0.00	3.00	4.00	25.61	0.03	1.06
LIT-11	0.49	0.49	0.00	0.99	0.010	0.021	0.10	0.00	3.00	4.00	28.96	0.03	1.04
LIT-11	0.41	0.41	0.00	1.00	0.010	0.021	0.10	0.00	3.00	4.00	30.87	0.02	1.03
LIT-11	1.64	1.40	0.24	0.85	0.020	0.021	0.14	0.00	3.00	4.00	20.97	0.04	1.55
LIT-11	1.28	1.12	0.16	0.88	0.020	0.021	0.13	0.00	3.00	4.00	23.04	0.03	1.53
LIT-11	1.00	0.92	0.08	0.92	0.020	0.021	0.12	0.00	3.00	4.00	25.27	0.03	1.51
LIT-11	0.73	0.71	0.02	0.97	0.020	0.021	0.11	0.00	3.00	4.00	28.37	0.03	1.48
LIT-11	0.45	0.45	0.00	1.00	0.020	0.021	0.09	0.00	3.00	4.00	34.05	0.02	1.43
LIT-11	2.47	1.95	0.51	0.79	0.040	0.021	0.15	0.00	3.00	4.00	20.48	0.04	2.20
LIT-11	1.77	1.50	0.27	0.85	0.040	0.021	0.13	0.00	3.00	4.00	23.20	0.03	2.16
LIT-11	1.27	1.15	0.12	0.91	0.040	0.021	0.11	0.00	3.00	4.00	26.28	0.03	2.12
LIT-11	0.90	0.87	0.03	0.97	0.040	0.021	0.10	0.00	3.00	4.00	29.94	0.03	2.07
LIT-11	0.46	0.46	0.00	1.00	0.040	0.021	0.08	0.00	3.00	4.00	38.55	0.02	1.98

Continued on next page

Table 5: Literature-Derived Performance Data for Drop-Type Inlets — Continued

ID-CODE	Q_A	Q_I	Q_O	Q_R	S_0	S_x	d_a	h_b	L_I	W_I	L_R	W_R	Fr
LIT-11	2.91	2.28	0.63	0.79	0.060	0.021	0.14	0.00	3.00	4.00	20.78	0.04	2.69
LIT-11	2.10	1.75	0.35	0.83	0.060	0.021	0.13	0.00	3.00	4.00	23.49	0.03	2.64
LIT-11	1.58	1.42	0.17	0.90	0.060	0.021	0.11	0.00	3.00	4.00	26.11	0.03	2.59
LIT-11	1.05	1.00	0.05	0.95	0.060	0.021	0.10	0.00	3.00	4.00	30.50	0.02	2.53
LIT-11	0.54	0.54	0.00	0.99	0.060	0.021	0.08	0.00	3.00	4.00	38.99	0.02	2.43
LIT-11	3.04	2.39	0.65	0.79	0.090	0.021	0.14	0.00	3.00	4.00	22.07	0.03	3.27
LIT-11	2.10	1.78	0.33	0.84	0.090	0.021	0.12	0.00	3.00	4.00	25.33	0.03	3.19
LIT-11	1.35	1.23	0.12	0.91	0.090	0.021	0.10	0.00	3.00	4.00	29.91	0.03	3.10
LIT-11	0.84	0.82	0.02	0.98	0.090	0.021	0.08	0.00	3.00	4.00	35.74	0.02	3.02
LIT-11	0.41	0.41	0.00	1.00	0.090	0.021	0.06	0.00	3.00	4.00	46.59	0.02	2.88
LIT-11	3.13	2.50	0.62	0.80	0.130	0.021	0.13	0.00	3.00	4.00	23.38	0.03	3.89
LIT-11	2.24	1.91	0.34	0.85	0.130	0.021	0.11	0.00	3.00	4.00	26.49	0.03	3.81
LIT-11	1.53	1.39	0.14	0.91	0.130	0.021	0.10	0.00	3.00	4.00	30.56	0.02	3.72
LIT-11	0.90	0.88	0.02	0.97	0.130	0.021	0.08	0.00	3.00	4.00	37.27	0.02	3.60
LIT-11	0.43	0.43	0.00	0.99	0.130	0.021	0.06	0.00	3.00	4.00	49.20	0.02	3.44
LIT-11	5.24	4.25	0.99	0.81	0.005	0.063	0.43	0.00	3.00	2.00	6.92	0.22	0.93
LIT-11	3.77	3.29	0.48	0.87	0.005	0.063	0.38	0.00	3.00	2.00	7.83	0.19	0.91
LIT-11	2.58	2.39	0.19	0.93	0.005	0.063	0.33	0.00	3.00	2.00	9.03	0.17	0.89
LIT-11	1.81	1.77	0.03	0.98	0.005	0.063	0.29	0.00	3.00	2.00	10.32	0.15	0.87
LIT-11	1.11	1.10	0.00	1.00	0.005	0.063	0.24	0.00	3.00	2.00	12.40	0.12	0.85
LIT-11	5.61	4.65	0.96	0.83	0.010	0.063	0.39	0.00	3.00	2.00	7.68	0.20	1.30
LIT-11	4.17	3.68	0.48	0.88	0.010	0.063	0.35	0.00	3.00	2.00	8.59	0.17	1.27
LIT-11	2.93	2.73	0.20	0.93	0.010	0.063	0.31	0.00	3.00	2.00	9.80	0.15	1.25
LIT-11	2.22	2.15	0.07	0.97	0.010	0.063	0.28	0.00	3.00	2.00	10.87	0.14	1.23
LIT-11	1.36	1.35	0.01	0.99	0.010	0.063	0.23	0.00	3.00	2.00	13.07	0.11	1.19
LIT-11	5.51	4.84	0.67	0.88	0.020	0.063	0.34	0.00	3.00	2.00	8.81	0.17	1.79
LIT-11	4.21	3.83	0.37	0.91	0.020	0.063	0.31	0.00	3.00	2.00	9.75	0.15	1.76
LIT-11	3.14	2.99	0.15	0.95	0.020	0.063	0.28	0.00	3.00	2.00	10.87	0.14	1.73
LIT-11	2.32	2.28	0.04	0.98	0.020	0.063	0.25	0.00	3.00	2.00	12.19	0.12	1.70
LIT-11	1.67	1.67	0.00	1.00	0.020	0.063	0.22	0.00	3.00	2.00	13.79	0.11	1.66
LIT-11	5.39	4.75	0.65	0.88	0.040	0.063	0.30	0.00	3.00	2.00	10.11	0.15	2.48
LIT-11	4.31	4.01	0.30	0.93	0.040	0.063	0.27	0.00	3.00	2.00	11.01	0.14	2.44
LIT-11	3.38	3.32	0.07	0.98	0.040	0.063	0.25	0.00	3.00	2.00	12.05	0.12	2.41
LIT-11	2.61	2.59	0.02	0.99	0.040	0.063	0.23	0.00	3.00	2.00	13.28	0.11	2.37
LIT-11	2.00	2.00	0.00	1.00	0.040	0.063	0.20	0.00	3.00	2.00	14.68	0.10	2.33
LIT-11	5.41	4.87	0.54	0.90	0.060	0.063	0.28	0.00	3.00	2.00	10.90	0.14	3.00
LIT-11	3.87	3.73	0.13	0.97	0.060	0.063	0.24	0.00	3.00	2.00	12.36	0.12	2.94
LIT-11	3.00	2.97	0.03	0.99	0.060	0.063	0.22	0.00	3.00	2.00	13.61	0.11	2.90
LIT-11	2.40	2.39	0.01	1.00	0.060	0.063	0.20	0.00	3.00	2.00	14.79	0.10	2.85

Continued on next page

Table 5: Literature-Derived Performance Data for Drop-Type Inlets — Continued

ID-CODE	Q_A	Q_I	Q_O	Q_R	S_0	S_x	d_a	h_b	L_I	W_I	L_R	W_R	Fr
LIT-11	5.51	4.96	0.55	0.90	0.090	0.063	0.26	0.00	3.00	2.00	11.68	0.13	3.63
LIT-11	4.32	4.05	0.27	0.94	0.090	0.063	0.23	0.00	3.00	2.00	12.79	0.12	3.58
LIT-11	2.95	2.90	0.06	0.98	0.090	0.063	0.20	0.00	3.00	2.00	14.76	0.10	3.49
LIT-11	2.49	2.48	0.01	1.00	0.090	0.063	0.19	0.00	3.00	2.00	15.73	0.10	3.45
LIT-11	2.19	2.19	0.00	1.00	0.090	0.063	0.18	0.00	3.00	2.00	16.51	0.09	3.43
LIT-11	5.31	4.30	1.02	0.81	0.130	0.063	0.24	0.00	3.00	2.00	12.69	0.12	4.30
LIT-11	4.41	3.98	0.43	0.90	0.130	0.063	0.22	0.00	3.00	2.00	13.61	0.11	4.25
LIT-11	3.33	3.17	0.16	0.95	0.130	0.063	0.20	0.00	3.00	2.00	15.12	0.10	4.18
LIT-11	2.36	2.31	0.05	0.98	0.130	0.063	0.17	0.00	3.00	2.00	17.19	0.09	4.09
LIT-11	1.91	1.90	0.01	1.00	0.130	0.063	0.16	0.00	3.00	2.00	18.62	0.08	4.04
LIT-11	2.61	2.17	0.43	0.83	0.005	0.042	0.29	0.00	3.00	2.00	10.44	0.14	0.87
LIT-11	1.80	1.60	0.20	0.89	0.005	0.042	0.25	0.00	3.00	2.00	12.01	0.12	0.85
LIT-11	0.91	0.88	0.03	0.97	0.005	0.042	0.19	0.00	3.00	2.00	15.52	0.10	0.82
LIT-11	0.58	0.58	0.00	1.00	0.005	0.042	0.16	0.00	3.00	2.00	18.34	0.08	0.79
LIT-11	3.52	2.83	0.69	0.80	0.010	0.042	0.28	0.00	3.00	2.00	10.62	0.14	1.23
LIT-11	2.36	2.05	0.32	0.87	0.010	0.042	0.24	0.00	3.00	2.00	12.33	0.12	1.20
LIT-11	1.57	1.47	0.10	0.94	0.010	0.042	0.21	0.00	3.00	2.00	14.39	0.10	1.17
LIT-11	0.89	0.88	0.01	0.99	0.010	0.042	0.17	0.00	3.00	2.00	17.80	0.08	1.13
LIT-11	0.66	0.66	0.00	1.00	0.010	0.042	0.15	0.00	3.00	2.00	19.89	0.08	1.11
LIT-11	4.91	3.81	1.10	0.78	0.020	0.042	0.28	0.00	3.00	2.00	10.68	0.14	1.74
LIT-11	3.29	2.78	0.50	0.85	0.020	0.042	0.24	0.00	3.00	2.00	12.42	0.12	1.69
LIT-11	2.09	1.93	0.15	0.93	0.020	0.042	0.20	0.00	3.00	2.00	14.72	0.10	1.65
LIT-11	1.24	1.22	0.02	0.99	0.020	0.042	0.17	0.00	3.00	2.00	17.91	0.08	1.59
LIT-11	0.86	0.86	0.00	1.00	0.020	0.042	0.15	0.00	3.00	2.00	20.53	0.07	1.56
LIT-11	5.49	4.35	1.14	0.79	0.040	0.042	0.26	0.00	3.00	2.00	11.66	0.13	2.42
LIT-11	3.80	3.29	0.50	0.87	0.040	0.042	0.22	0.00	3.00	2.00	13.39	0.11	2.37
LIT-11	2.28	2.16	0.12	0.95	0.040	0.042	0.19	0.00	3.00	2.00	16.21	0.09	2.29
LIT-11	1.24	1.24	0.00	1.00	0.040	0.042	0.15	0.00	3.00	2.00	20.38	0.07	2.21
LIT-11	5.44	4.53	0.91	0.83	0.060	0.042	0.24	0.00	3.00	2.00	12.63	0.12	2.93
LIT-11	3.58	3.20	0.38	0.90	0.060	0.042	0.20	0.00	3.00	2.00	14.78	0.10	2.85
LIT-11	2.13	2.08	0.05	0.98	0.060	0.042	0.17	0.00	3.00	2.00	17.96	0.08	2.76
LIT-11	1.29	1.29	0.01	0.99	0.060	0.042	0.14	0.00	3.00	2.00	21.64	0.07	2.67
LIT-11	0.98	0.98	0.00	1.00	0.060	0.042	0.12	0.00	3.00	2.00	24.05	0.06	2.63
LIT-11	5.33	4.42	0.92	0.83	0.090	0.042	0.22	0.00	3.00	2.00	13.73	0.11	3.53
LIT-11	3.52	3.19	0.32	0.91	0.090	0.042	0.19	0.00	3.00	2.00	16.05	0.09	3.44
LIT-11	2.13	2.08	0.05	0.98	0.090	0.042	0.15	0.00	3.00	2.00	19.38	0.08	3.34
LIT-11	1.39	1.39	0.00	1.00	0.090	0.042	0.13	0.00	3.00	2.00	22.74	0.07	3.25
LIT-11	5.23	4.30	0.93	0.82	0.130	0.042	0.20	0.00	3.00	2.00	14.81	0.10	4.19
LIT-11	3.97	3.61	0.36	0.91	0.130	0.042	0.18	0.00	3.00	2.00	16.43	0.09	4.12

Continued on next page

Table 5: Literature-Derived Performance Data for Drop-Type Inlets — Continued

ID-CODE	Q_A	Q_I	Q_O	Q_R	S_0	S_x	d_a	h_b	L_I	W_I	L_R	W_R	Fr
LIT-11	2.53	2.43	0.10	0.96	0.130	0.042	0.15	0.00	3.00	2.00	19.45	0.08	4.01
LIT-11	1.42	1.42	0.01	0.99	0.130	0.042	0.12	0.00	3.00	2.00	24.13	0.06	3.87
LIT-11	0.89	0.76	0.13	0.85	0.005	0.021	0.15	0.00	3.00	2.00	20.33	0.07	0.78
LIT-11	0.71	0.63	0.07	0.90	0.005	0.021	0.14	0.00	3.00	2.00	22.16	0.07	0.77
LIT-11	0.51	0.49	0.03	0.95	0.005	0.021	0.12	0.00	3.00	2.00	25.02	0.06	0.76
LIT-11	0.33	0.32	0.00	0.99	0.005	0.021	0.10	0.00	3.00	2.00	29.63	0.05	0.73
LIT-11	1.17	0.97	0.21	0.83	0.010	0.021	0.14	0.00	3.00	2.00	20.88	0.07	1.10
LIT-11	0.78	0.69	0.10	0.88	0.010	0.021	0.12	0.00	3.00	2.00	24.28	0.06	1.07
LIT-11	0.59	0.55	0.04	0.93	0.010	0.021	0.11	0.00	3.00	2.00	26.98	0.06	1.05
LIT-11	0.32	0.32	0.00	1.00	0.010	0.021	0.09	0.00	3.00	2.00	33.99	0.04	1.01
LIT-11	1.65	1.26	0.39	0.76	0.020	0.021	0.14	0.00	3.00	2.00	20.94	0.07	1.55
LIT-11	1.10	0.94	0.16	0.85	0.020	0.021	0.12	0.00	3.00	2.00	24.38	0.06	1.52
LIT-11	0.70	0.65	0.04	0.94	0.020	0.021	0.10	0.00	3.00	2.00	28.88	0.05	1.47
LIT-11	0.40	0.40	0.00	0.99	0.020	0.021	0.08	0.00	3.00	2.00	35.62	0.04	1.42
LIT-11	2.32	1.75	0.57	0.76	0.040	0.021	0.14	0.00	3.00	2.00	20.96	0.07	2.20
LIT-11	1.55	1.27	0.28	0.82	0.040	0.021	0.12	0.00	3.00	2.00	24.41	0.06	2.14
LIT-11	0.98	0.88	0.10	0.90	0.040	0.021	0.10	0.00	3.00	2.00	28.98	0.05	2.08
LIT-11	0.56	0.55	0.01	0.98	0.040	0.021	0.08	0.00	3.00	2.00	35.72	0.04	2.01
LIT-11	0.29	0.29	0.00	1.00	0.040	0.021	0.07	0.00	3.00	2.00	45.64	0.03	1.93
LIT-11	3.01	2.23	0.78	0.74	0.060	0.021	0.15	0.00	3.00	2.00	20.51	0.07	2.70
LIT-11	1.97	1.60	0.37	0.81	0.060	0.021	0.12	0.00	3.00	2.00	24.07	0.06	2.63
LIT-11	1.26	1.10	0.16	0.87	0.060	0.021	0.11	0.00	3.00	2.00	28.40	0.05	2.56
LIT-11	0.72	0.69	0.02	0.97	0.060	0.021	0.09	0.00	3.00	2.00	35.17	0.04	2.47
LIT-11	0.32	0.31	0.00	0.99	0.060	0.021	0.06	0.00	3.00	2.00	47.79	0.03	2.34
LIT-11	3.07	2.31	0.76	0.75	0.090	0.021	0.14	0.00	3.00	2.00	21.97	0.07	3.27
LIT-11	2.00	1.64	0.36	0.82	0.090	0.021	0.12	0.00	3.00	2.00	25.82	0.06	3.18
LIT-11	1.34	1.20	0.14	0.89	0.090	0.021	0.10	0.00	3.00	2.00	29.97	0.05	3.10
LIT-11	0.74	0.72	0.02	0.97	0.090	0.021	0.08	0.00	3.00	2.00	37.41	0.04	2.99
LIT-11	0.35	0.35	0.00	0.99	0.090	0.021	0.06	0.00	3.00	2.00	49.71	0.03	2.85
LIT-11	3.52	2.62	0.89	0.75	0.130	0.021	0.13	0.00	3.00	2.00	22.38	0.07	3.92
LIT-11	2.27	1.86	0.41	0.82	0.130	0.021	0.11	0.00	3.00	2.00	26.36	0.06	3.81
LIT-11	1.44	1.31	0.13	0.91	0.130	0.021	0.10	0.00	3.00	2.00	31.26	0.05	3.71
LIT-11	0.84	0.81	0.03	0.97	0.130	0.021	0.08	0.00	3.00	2.00	38.26	0.04	3.58
LIT-11	0.44	0.43	0.00	0.99	0.130	0.021	0.06	0.00	3.00	2.00	48.86	0.03	3.44
LIT-11	4.56	2.46	2.10	0.54	0.005	0.063	0.41	0.00	1.25	2.67	3.04	0.15	0.93
LIT-11	3.25	2.01	1.24	0.62	0.005	0.063	0.36	0.00	1.25	2.67	3.45	0.14	0.91
LIT-11	2.32	1.58	0.74	0.68	0.005	0.063	0.32	0.00	1.25	2.67	3.92	0.12	0.89
LIT-11	1.37	1.07	0.30	0.78	0.005	0.063	0.26	0.00	1.25	2.67	4.77	0.10	0.86
LIT-11	0.27	0.27	0.00	0.99	0.005	0.063	0.14	0.00	1.25	2.67	8.78	0.05	0.78

Continued on next page

Table 5: Literature-Derived Performance Data for Drop-Type Inlets — Continued

ID-CODE	Q_A	Q_I	Q_O	Q_R	S_0	S_x	d_a	h_b	L_I	W_I	L_R	W_R	Fr
LIT-11	5.50	2.62	2.89	0.48	0.010	0.063	0.39	0.00	1.25	2.67	3.23	0.15	1.30
LIT-11	3.85	2.20	1.65	0.57	0.010	0.063	0.34	0.00	1.25	2.67	3.69	0.13	1.27
LIT-11	2.41	1.60	0.81	0.66	0.010	0.063	0.28	0.00	1.25	2.67	4.40	0.11	1.23
LIT-11	0.90	0.77	0.14	0.85	0.010	0.063	0.20	0.00	1.25	2.67	6.35	0.07	1.16
LIT-11	0.26	0.26	0.00	0.99	0.010	0.063	0.12	0.00	1.25	2.67	10.15	0.05	1.07
LIT-11	5.50	2.78	2.72	0.51	0.020	0.063	0.34	0.00	1.25	2.67	3.67	0.13	1.79
LIT-11	3.24	2.01	1.24	0.62	0.020	0.063	0.28	0.00	1.25	2.67	4.48	0.10	1.74
LIT-11	1.88	1.37	0.51	0.73	0.020	0.063	0.23	0.00	1.25	2.67	5.50	0.09	1.68
LIT-11	0.83	0.73	0.10	0.88	0.020	0.063	0.17	0.00	1.25	2.67	7.46	0.06	1.59
LIT-11	0.29	0.29	0.00	0.99	0.020	0.063	0.11	0.00	1.25	2.67	11.03	0.04	1.50
LIT-11	5.49	2.93	2.55	0.53	0.040	0.063	0.30	0.00	1.25	2.67	4.19	0.11	2.48
LIT-11	3.41	2.24	1.16	0.66	0.040	0.063	0.25	0.00	1.25	2.67	5.01	0.09	2.41
LIT-11	1.72	1.33	0.39	0.77	0.040	0.063	0.19	0.00	1.25	2.67	6.47	0.07	2.31
LIT-11	0.75	0.70	0.06	0.92	0.040	0.063	0.14	0.00	1.25	2.67	8.81	0.05	2.19
LIT-11	0.36	0.36	0.00	0.99	0.040	0.063	0.11	0.00	1.25	2.67	11.62	0.04	2.10
LIT-11	5.45	2.93	2.52	0.54	0.060	0.063	0.28	0.00	1.25	2.67	4.53	0.10	3.00
LIT-11	3.40	2.24	1.16	0.66	0.060	0.063	0.23	0.00	1.25	2.67	5.40	0.09	2.91
LIT-11	1.71	1.36	0.34	0.80	0.060	0.063	0.18	0.00	1.25	2.67	7.00	0.07	2.79
LIT-11	0.84	0.78	0.06	0.93	0.060	0.063	0.14	0.00	1.25	2.67	9.13	0.05	2.67
LIT-11	0.39	0.39	0.00	0.99	0.060	0.063	0.10	0.00	1.25	2.67	12.16	0.04	2.55
LIT-11	5.35	2.81	2.55	0.52	0.090	0.063	0.25	0.00	1.25	2.67	4.92	0.10	3.62
LIT-11	2.78	1.95	0.82	0.70	0.090	0.063	0.20	0.00	1.25	2.67	6.29	0.07	3.48
LIT-11	1.70	1.36	0.34	0.80	0.090	0.063	0.17	0.00	1.25	2.67	7.56	0.06	3.37
LIT-11	0.84	0.78	0.06	0.93	0.090	0.063	0.13	0.00	1.25	2.67	9.85	0.05	3.23
LIT-11	0.39	0.38	0.00	0.99	0.090	0.063	0.09	0.00	1.25	2.67	13.16	0.04	3.08
LIT-11	5.23	2.59	2.64	0.50	0.130	0.063	0.24	0.00	1.25	2.67	5.32	0.09	4.30
LIT-11	2.81	1.97	0.84	0.70	0.130	0.063	0.19	0.00	1.25	2.67	6.71	0.07	4.14
LIT-11	1.70	1.40	0.30	0.82	0.130	0.063	0.15	0.00	1.25	2.67	8.11	0.06	4.01
LIT-11	0.78	0.75	0.04	0.95	0.130	0.063	0.12	0.00	1.25	2.67	10.84	0.04	3.82
LIT-11	0.40	0.39	0.00	0.99	0.130	0.063	0.09	0.00	1.25	2.67	14.00	0.03	3.66
LIT-11	2.13	1.24	0.88	0.58	0.005	0.042	0.27	0.00	1.25	2.67	4.70	0.10	0.86
LIT-11	1.13	0.79	0.33	0.70	0.005	0.042	0.21	0.00	1.25	2.67	5.96	0.08	0.83
LIT-11	0.62	0.50	0.12	0.81	0.005	0.042	0.17	0.00	1.25	2.67	7.45	0.06	0.80
LIT-11	0.30	0.27	0.02	0.92	0.005	0.042	0.13	0.00	1.25	2.67	9.83	0.05	0.76
LIT-11	0.11	0.11	0.00	0.98	0.005	0.042	0.09	0.00	1.25	2.67	14.10	0.03	0.72
LIT-11	2.96	1.50	1.46	0.51	0.010	0.042	0.26	0.00	1.25	2.67	4.72	0.10	1.22
LIT-11	1.53	0.96	0.57	0.63	0.010	0.042	0.21	0.00	1.25	2.67	6.05	0.08	1.17
LIT-11	0.90	0.66	0.24	0.74	0.010	0.042	0.17	0.00	1.25	2.67	7.38	0.06	1.13
LIT-11	0.46	0.39	0.07	0.84	0.010	0.042	0.13	0.00	1.25	2.67	9.48	0.05	1.08

Continued on next page

Table 5: Literature-Derived Performance Data for Drop-Type Inlets — Continued

ID-CODE	Q_A	Q_I	Q_O	Q_R	S_0	S_x	d_a	h_b	L_I	W_I	L_R	W_R	Fr
LIT-11	0.13	0.13	0.00	0.99	0.010	0.042	0.08	0.00	1.25	2.67	15.10	0.03	1.00
LIT-11	4.08	1.93	2.14	0.47	0.020	0.042	0.26	0.00	1.25	2.67	4.77	0.10	1.72
LIT-11	2.70	1.45	1.25	0.54	0.020	0.042	0.22	0.00	1.25	2.67	5.56	0.08	1.67
LIT-11	1.53	0.99	0.54	0.65	0.020	0.042	0.18	0.00	1.25	2.67	6.88	0.07	1.61
LIT-11	0.63	0.51	0.12	0.81	0.020	0.042	0.13	0.00	1.25	2.67	9.62	0.05	1.53
LIT-11	0.17	0.17	0.00	0.99	0.020	0.042	0.08	0.00	1.25	2.67	15.57	0.03	1.41
LIT-11	5.48	2.42	3.06	0.44	0.040	0.042	0.26	0.00	1.25	2.67	4.86	0.10	2.42
LIT-11	2.94	1.65	1.29	0.56	0.040	0.042	0.20	0.00	1.25	2.67	6.14	0.08	2.33
LIT-11	1.76	1.14	0.63	0.65	0.040	0.042	0.17	0.00	1.25	2.67	7.44	0.06	2.26
LIT-11	0.89	0.71	0.18	0.80	0.040	0.042	0.13	0.00	1.25	2.67	9.62	0.05	2.16
LIT-11	0.18	0.17	0.00	0.98	0.040	0.042	0.07	0.00	1.25	2.67	17.69	0.03	1.96
LIT-11	5.42	2.44	2.99	0.45	0.060	0.042	0.24	0.00	1.25	2.67	5.27	0.09	2.93
LIT-11	2.75	1.62	1.13	0.59	0.060	0.042	0.18	0.00	1.25	2.67	6.79	0.07	2.80
LIT-11	1.59	1.10	0.50	0.69	0.060	0.042	0.15	0.00	1.25	2.67	8.34	0.06	2.71
LIT-11	0.68	0.58	0.10	0.85	0.060	0.042	0.11	0.00	1.25	2.67	11.45	0.04	2.57
LIT-11	0.21	0.21	0.00	0.99	0.060	0.042	0.07	0.00	1.25	2.67	17.79	0.03	2.39
LIT-11	5.33	2.48	2.85	0.47	0.090	0.042	0.22	0.00	1.25	2.67	5.72	0.08	3.53
LIT-11	3.30	1.86	1.44	0.56	0.090	0.042	0.18	0.00	1.25	2.67	6.85	0.07	3.43
LIT-11	1.83	1.25	0.59	0.68	0.090	0.042	0.15	0.00	1.25	2.67	8.53	0.05	3.31
LIT-11	0.86	0.72	0.14	0.84	0.090	0.042	0.11	0.00	1.25	2.67	11.34	0.04	3.15
LIT-11	0.19	0.19	0.00	0.99	0.090	0.042	0.06	0.00	1.25	2.67	19.84	0.02	2.88
LIT-11	5.21	2.38	2.83	0.46	0.130	0.042	0.20	0.00	1.25	2.67	6.18	0.08	4.19
LIT-11	3.72	2.01	1.71	0.54	0.130	0.042	0.18	0.00	1.25	2.67	7.01	0.07	4.11
LIT-11	1.90	1.26	0.64	0.66	0.130	0.042	0.14	0.00	1.25	2.67	9.02	0.05	3.94
LIT-11	0.81	0.67	0.14	0.83	0.130	0.042	0.10	0.00	1.25	2.67	12.45	0.04	3.73
LIT-11	0.18	0.18	0.00	1.00	0.130	0.042	0.06	0.00	1.25	2.67	21.83	0.02	3.40
LIT-11	1.31	0.64	0.68	0.48	0.005	0.021	0.17	0.00	1.25	2.67	7.32	0.06	0.80
LIT-11	0.69	0.39	0.31	0.56	0.005	0.021	0.13	0.00	1.25	2.67	9.30	0.05	0.77
LIT-11	0.49	0.32	0.17	0.65	0.005	0.021	0.12	0.00	1.25	2.67	10.57	0.04	0.75
LIT-11	0.25	0.21	0.04	0.83	0.005	0.021	0.09	0.00	1.25	2.67	13.61	0.03	0.72
LIT-11	0.06	0.05	0.00	0.92	0.005	0.021	0.05	0.00	1.25	2.67	23.78	0.02	0.65
LIT-11	0.02	0.02	0.00	0.97	0.005	0.021	0.04	0.00	1.25	2.67	34.88	0.01	0.60
LIT-11	0.82	0.46	0.36	0.56	0.010	0.021	0.13	0.00	1.25	2.67	9.94	0.05	1.07
LIT-11	0.49	0.32	0.17	0.65	0.010	0.021	0.10	0.00	1.25	2.67	12.04	0.04	1.04
LIT-11	0.41	0.28	0.13	0.68	0.010	0.021	0.10	0.00	1.25	2.67	12.96	0.04	1.03
LIT-11	0.24	0.20	0.04	0.84	0.010	0.021	0.08	0.00	1.25	2.67	15.75	0.03	1.00
LIT-11	0.11	0.10	0.01	0.92	0.010	0.021	0.06	0.00	1.25	2.67	21.10	0.02	0.95
LIT-11	0.04	0.04	0.00	1.00	0.010	0.021	0.04	0.00	1.25	2.67	32.32	0.01	0.88
LIT-11	0.95	0.52	0.44	0.54	0.020	0.021	0.12	0.00	1.25	2.67	10.70	0.04	1.50

Continued on next page

Table 5: Literature-Derived Performance Data for Drop-Type Inlets — Continued

ID-CODE	Q_A	Q_I	Q_O	Q_R	S_0	S_x	d_a	h_b	L_I	W_I	L_R	W_R	Fr
LIT-11	0.50	0.32	0.17	0.65	0.020	0.021	0.09	0.00	1.25	2.67	13.67	0.03	1.44
LIT-11	0.29	0.23	0.06	0.78	0.020	0.021	0.07	0.00	1.25	2.67	16.75	0.03	1.40
LIT-11	0.21	0.18	0.03	0.88	0.020	0.021	0.07	0.00	1.25	2.67	18.87	0.02	1.37
LIT-11	0.15	0.14	0.01	0.93	0.020	0.021	0.06	0.00	1.25	2.67	21.23	0.02	1.34
LIT-11	0.07	0.06	0.00	0.98	0.020	0.021	0.04	0.00	1.25	2.67	29.26	0.02	1.28
LIT-11	1.91	0.88	1.04	0.46	0.040	0.021	0.13	0.00	1.25	2.67	9.39	0.05	2.17
LIT-11	1.00	0.56	0.44	0.56	0.040	0.021	0.10	0.00	1.25	2.67	11.98	0.04	2.08
LIT-11	0.57	0.38	0.19	0.67	0.040	0.021	0.08	0.00	1.25	2.67	14.81	0.03	2.01
LIT-11	0.27	0.23	0.05	0.83	0.040	0.021	0.06	0.00	1.25	2.67	19.50	0.02	1.92
LIT-11	0.07	0.06	0.00	0.95	0.040	0.021	0.04	0.00	1.25	2.67	33.20	0.01	1.74
LIT-11	2.37	1.03	1.34	0.43	0.060	0.021	0.13	0.00	1.25	2.67	9.35	0.05	2.66
LIT-11	1.23	0.66	0.57	0.54	0.060	0.021	0.10	0.00	1.25	2.67	11.96	0.04	2.55
LIT-11	0.71	0.47	0.24	0.67	0.060	0.021	0.08	0.00	1.25	2.67	14.72	0.03	2.47
LIT-11	0.34	0.27	0.07	0.79	0.060	0.021	0.06	0.00	1.25	2.67	19.42	0.02	2.35
LIT-11	0.10	0.09	0.00	0.97	0.060	0.021	0.04	0.00	1.25	2.67	31.02	0.02	2.17
LIT-11	2.47	1.09	1.38	0.44	0.090	0.021	0.13	0.00	1.25	2.67	9.93	0.05	3.22
LIT-11	1.30	0.70	0.60	0.54	0.090	0.021	0.10	0.00	1.25	2.67	12.62	0.04	3.10
LIT-11	0.73	0.46	0.28	0.62	0.090	0.021	0.08	0.00	1.25	2.67	15.66	0.03	2.99
LIT-11	0.38	0.29	0.09	0.76	0.090	0.021	0.06	0.00	1.25	2.67	20.04	0.02	2.87
LIT-11	0.11	0.11	0.01	0.95	0.090	0.021	0.04	0.00	1.25	2.67	31.79	0.01	2.66
LIT-11	2.84	1.21	1.62	0.43	0.130	0.021	0.12	0.00	1.25	2.67	10.11	0.05	3.86
LIT-11	1.45	0.75	0.70	0.52	0.130	0.021	0.10	0.00	1.25	2.67	13.01	0.04	3.71
LIT-11	0.64	0.41	0.23	0.64	0.130	0.021	0.07	0.00	1.25	2.67	17.62	0.03	3.52
LIT-11	0.33	0.26	0.07	0.78	0.130	0.021	0.06	0.00	1.25	2.67	22.54	0.02	3.38
LIT-11	0.09	0.09	0.00	0.98	0.130	0.021	0.03	0.00	1.25	2.67	36.53	0.01	3.13
LIT-11	5.24	2.42	2.82	0.46	0.005	0.063	0.43	0.00	1.25	2.00	2.88	0.22	0.93
LIT-11	3.95	2.08	1.87	0.53	0.005	0.063	0.39	0.00	1.25	2.00	3.21	0.19	0.92
LIT-11	2.44	1.49	0.95	0.61	0.005	0.063	0.33	0.00	1.25	2.00	3.84	0.16	0.89
LIT-11	1.59	1.14	0.46	0.71	0.005	0.063	0.28	0.00	1.25	2.00	4.51	0.14	0.87
LIT-11	0.90	0.72	0.18	0.80	0.005	0.063	0.22	0.00	1.25	2.00	5.58	0.11	0.84
LIT-11	0.16	0.16	0.00	0.99	0.005	0.063	0.12	0.00	1.25	2.00	10.56	0.06	0.75
LIT-11	5.53	2.43	3.11	0.44	0.010	0.063	0.39	0.00	1.25	2.00	3.22	0.19	1.30
LIT-11	3.95	2.08	1.87	0.53	0.010	0.063	0.34	0.00	1.25	2.00	3.65	0.17	1.27
LIT-11	2.41	1.48	0.93	0.61	0.010	0.063	0.28	0.00	1.25	2.00	4.39	0.14	1.23
LIT-11	1.46	1.07	0.39	0.73	0.010	0.063	0.24	0.00	1.25	2.00	5.30	0.12	1.19
LIT-11	0.70	0.60	0.10	0.86	0.010	0.063	0.18	0.00	1.25	2.00	6.99	0.09	1.14
LIT-11	0.14	0.13	0.00	0.99	0.010	0.063	0.10	0.00	1.25	2.00	12.91	0.05	1.03
LIT-11	5.54	2.57	2.97	0.46	0.020	0.063	0.34	0.00	1.25	2.00	3.66	0.17	1.79
LIT-11	3.29	1.90	1.39	0.58	0.020	0.063	0.28	0.00	1.25	2.00	4.46	0.14	1.74

Continued on next page

Table 5: Literature-Derived Performance Data for Drop-Type Inlets — Continued

ID-CODE	Q_A	Q_I	Q_O	Q_R	S_0	S_x	d_a	h_b	L_I	W_I	L_R	W_R	Fr
LIT-11	1.82	1.26	0.56	0.69	0.020	0.063	0.22	0.00	1.25	2.00	5.56	0.11	1.67
LIT-11	0.78	0.66	0.11	0.85	0.020	0.063	0.16	0.00	1.25	2.00	7.66	0.08	1.59
LIT-11	0.25	0.24	0.01	0.97	0.020	0.063	0.11	0.00	1.25	2.00	11.76	0.05	1.48
LIT-11	5.54	2.71	2.83	0.49	0.040	0.063	0.30	0.00	1.25	2.00	4.17	0.15	2.48
LIT-11	3.35	2.03	1.32	0.61	0.040	0.063	0.25	0.00	1.25	2.00	5.04	0.12	2.41
LIT-11	1.72	1.26	0.46	0.73	0.040	0.063	0.19	0.00	1.25	2.00	6.47	0.10	2.31
LIT-11	0.44	0.42	0.02	0.95	0.040	0.063	0.12	0.00	1.25	2.00	10.75	0.06	2.12
LIT-11	0.18	0.17	0.00	0.99	0.040	0.063	0.08	0.00	1.25	2.00	15.22	0.04	1.99
LIT-11	5.48	2.70	2.78	0.49	0.060	0.063	0.28	0.00	1.25	2.00	4.52	0.14	3.00
LIT-11	3.03	1.97	1.05	0.65	0.060	0.063	0.22	0.00	1.25	2.00	5.65	0.11	2.89
LIT-11	2.19	1.56	0.63	0.71	0.060	0.063	0.20	0.00	1.25	2.00	6.37	0.10	2.83
LIT-11	1.00	0.87	0.13	0.87	0.060	0.063	0.15	0.00	1.25	2.00	8.54	0.07	2.70
LIT-11	0.18	0.18	0.00	0.99	0.060	0.063	0.08	0.00	1.25	2.00	16.37	0.04	2.43
LIT-11	5.54	2.42	3.12	0.44	0.090	0.063	0.26	0.00	1.25	2.00	4.86	0.13	3.63
LIT-11	3.97	2.12	1.85	0.53	0.090	0.063	0.23	0.00	1.25	2.00	5.50	0.11	3.56
LIT-11	2.55	1.77	0.78	0.69	0.090	0.063	0.19	0.00	1.25	2.00	6.49	0.10	3.46
LIT-11	0.96	0.86	0.10	0.90	0.090	0.063	0.13	0.00	1.25	2.00	9.36	0.07	3.26
LIT-11	0.18	0.18	0.00	0.99	0.090	0.063	0.07	0.00	1.25	2.00	17.59	0.04	2.93
LIT-11	5.24	1.89	3.35	0.36	0.130	0.063	0.24	0.00	1.25	2.00	5.31	0.12	4.30
LIT-11	3.93	1.77	2.16	0.45	0.130	0.063	0.21	0.00	1.25	2.00	5.92	0.11	4.22
LIT-11	1.01	0.92	0.09	0.91	0.130	0.063	0.13	0.00	1.25	2.00	9.86	0.06	3.88
LIT-11	0.41	0.40	0.01	0.98	0.130	0.063	0.09	0.00	1.25	2.00	13.83	0.05	3.66
LIT-11	0.23	0.23	0.00	1.00	0.130	0.063	0.07	0.00	1.25	2.00	17.21	0.04	3.54
LIT-11	2.56	1.28	1.28	0.50	0.005	0.042	0.29	0.00	1.25	2.00	4.38	0.14	0.87
LIT-11	1.39	0.85	0.54	0.61	0.005	0.042	0.23	0.00	1.25	2.00	5.50	0.11	0.84
LIT-11	0.86	0.60	0.27	0.69	0.005	0.042	0.19	0.00	1.25	2.00	6.58	0.09	0.81
LIT-11	0.33	0.30	0.03	0.91	0.005	0.042	0.13	0.00	1.25	2.00	9.41	0.07	0.77
LIT-11	0.05	0.05	0.00	0.99	0.005	0.042	0.07	0.00	1.25	2.00	18.74	0.03	0.69
LIT-11	3.31	1.49	1.83	0.45	0.010	0.042	0.28	0.00	1.25	2.00	4.53	0.14	1.23
LIT-11	1.97	1.08	0.89	0.55	0.010	0.042	0.23	0.00	1.25	2.00	5.51	0.11	1.19
LIT-11	1.02	0.76	0.27	0.74	0.010	0.042	0.18	0.00	1.25	2.00	7.03	0.09	1.14
LIT-11	0.54	0.47	0.07	0.87	0.010	0.042	0.14	0.00	1.25	2.00	8.95	0.07	1.09
LIT-11	0.11	0.11	0.00	0.99	0.010	0.042	0.08	0.00	1.25	2.00	16.41	0.04	0.99
LIT-11	4.14	1.86	2.28	0.45	0.020	0.042	0.26	0.00	1.25	2.00	4.74	0.13	1.72
LIT-11	2.70	1.37	1.33	0.51	0.020	0.042	0.22	0.00	1.25	2.00	5.57	0.11	1.67
LIT-11	1.53	0.93	0.59	0.61	0.020	0.042	0.18	0.00	1.25	2.00	6.89	0.09	1.61
LIT-11	0.63	0.47	0.16	0.75	0.020	0.042	0.13	0.00	1.25	2.00	9.62	0.06	1.53
LIT-11	0.09	0.09	0.00	0.99	0.020	0.042	0.06	0.00	1.25	2.00	19.92	0.03	1.35
LIT-11	5.53	2.26	3.27	0.41	0.040	0.042	0.26	0.00	1.25	2.00	4.85	0.13	2.42

Continued on next page

Table 5: Literature-Derived Performance Data for Drop-Type Inlets — Continued

ID-CODE	Q_A	Q_I	Q_O	Q_R	S_0	S_x	d_a	h_b	L_I	W_I	L_R	W_R	Fr
LIT-11	3.25	1.67	1.58	0.52	0.040	0.042	0.21	0.00	1.25	2.00	5.91	0.11	2.34
LIT-11	2.24	1.30	0.93	0.58	0.040	0.042	0.18	0.00	1.25	2.00	6.81	0.09	2.29
LIT-11	1.35	0.89	0.46	0.66	0.040	0.042	0.15	0.00	1.25	2.00	8.22	0.08	2.22
LIT-11	0.57	0.46	0.11	0.81	0.040	0.042	0.11	0.00	1.25	2.00	11.38	0.05	2.10
LIT-11	0.09	0.09	0.00	0.99	0.040	0.042	0.06	0.00	1.25	2.00	22.54	0.03	1.88
LIT-11	5.43	2.42	3.01	0.45	0.060	0.042	0.24	0.00	1.25	2.00	5.27	0.12	2.93
LIT-11	3.25	1.73	1.51	0.53	0.060	0.042	0.20	0.00	1.25	2.00	6.39	0.10	2.83
LIT-11	1.56	1.08	0.48	0.69	0.060	0.042	0.15	0.00	1.25	2.00	8.41	0.07	2.71
LIT-11	0.70	0.57	0.13	0.81	0.060	0.042	0.11	0.00	1.25	2.00	11.33	0.06	2.58
LIT-11	0.11	0.11	0.00	0.99	0.060	0.042	0.06	0.00	1.25	2.00	22.50	0.03	2.29
LIT-11	5.37	2.10	3.27	0.39	0.090	0.042	0.22	0.00	1.25	2.00	5.70	0.11	3.54
LIT-11	3.20	1.77	1.42	0.55	0.090	0.042	0.18	0.00	1.25	2.00	6.93	0.09	3.42
LIT-11	1.82	1.23	0.60	0.67	0.090	0.042	0.15	0.00	1.25	2.00	8.55	0.07	3.31
LIT-11	0.84	0.68	0.16	0.81	0.090	0.042	0.11	0.00	1.25	2.00	11.44	0.05	3.15
LIT-11	0.10	0.10	0.00	0.99	0.090	0.042	0.05	0.00	1.25	2.00	25.30	0.02	2.76
LIT-11	5.24	1.82	3.42	0.35	0.130	0.042	0.20	0.00	1.25	2.00	6.17	0.10	4.19
LIT-11	3.96	1.77	2.19	0.45	0.130	0.042	0.18	0.00	1.25	2.00	6.85	0.09	4.12
LIT-11	2.53	1.41	1.12	0.56	0.130	0.042	0.15	0.00	1.25	2.00	8.10	0.08	4.01
LIT-11	1.36	0.90	0.47	0.66	0.130	0.042	0.12	0.00	1.25	2.00	10.22	0.06	3.86
LIT-11	0.27	0.25	0.02	0.92	0.130	0.042	0.07	0.00	1.25	2.00	18.85	0.03	3.48
LIT-11	0.72	0.39	0.33	0.54	0.005	0.042	0.18	0.00	1.25	2.00	7.05	0.09	0.80
LIT-11	0.35	0.25	0.10	0.70	0.005	0.042	0.14	0.00	1.25	2.00	9.23	0.07	0.77
LIT-11	0.22	0.18	0.04	0.81	0.005	0.042	0.11	0.00	1.25	2.00	11.01	0.06	0.74
LIT-11	0.11	0.10	0.01	0.89	0.005	0.042	0.09	0.00	1.25	2.00	14.39	0.04	0.72
LIT-11	0.03	0.03	0.00	0.93	0.005	0.042	0.06	0.00	1.25	2.00	22.58	0.03	0.67
LIT-11	0.01	0.01	0.00	0.99	0.005	0.042	0.04	0.00	1.25	2.00	30.80	0.02	0.64
LIT-11	1.01	0.52	0.49	0.51	0.010	0.021	0.14	0.00	1.25	2.00	9.21	0.07	1.09
LIT-11	0.33	0.23	0.10	0.71	0.010	0.021	0.09	0.00	1.25	2.00	14.00	0.04	1.01
LIT-11	0.14	0.12	0.02	0.89	0.010	0.021	0.06	0.00	1.25	2.00	19.40	0.03	0.96
LIT-11	0.02	0.02	0.00	0.95	0.010	0.021	0.03	0.00	1.25	2.00	37.47	0.02	0.85
LIT-11	0.03	0.03	0.00	0.99	0.010	0.021	0.04	0.00	1.25	2.00	32.66	0.02	0.89
LIT-11	1.61	0.70	0.91	0.43	0.020	0.021	0.14	0.00	1.25	2.00	8.80	0.07	1.55
LIT-11	0.90	0.46	0.44	0.51	0.020	0.021	0.11	0.00	1.25	2.00	10.93	0.06	1.50
LIT-11	0.52	0.31	0.21	0.60	0.020	0.021	0.09	0.00	1.25	2.00	13.46	0.05	1.44
LIT-11	0.30	0.21	0.08	0.72	0.020	0.021	0.08	0.00	1.25	2.00	16.62	0.04	1.40
LIT-11	0.16	0.14	0.02	0.89	0.020	0.021	0.06	0.00	1.25	2.00	21.07	0.03	1.34
LIT-11	0.04	0.04	0.00	0.99	0.020	0.021	0.04	0.00	1.25	2.00	33.72	0.02	1.22
LIT-11	1.93	0.83	1.10	0.43	0.040	0.021	0.13	0.00	1.25	2.00	9.36	0.07	2.17
LIT-11	1.02	0.55	0.47	0.54	0.040	0.021	0.11	0.00	1.25	2.00	11.88	0.05	2.09

Continued on next page

Table 5: Literature-Derived Performance Data for Drop-Type Inlets — Continued

ID-CODE	Q_A	Q_I	Q_O	Q_R	S_0	S_x	d_a	h_b	L_I	W_I	L_R	W_R	Fr
LIT-11	0.44	0.31	0.13	0.71	0.040	0.021	0.08	0.00	1.25	2.00	16.34	0.04	1.98
LIT-11	0.18	0.16	0.02	0.88	0.040	0.021	0.05	0.00	1.25	2.00	22.97	0.03	1.88
LIT-11	0.05	0.05	0.00	0.95	0.040	0.021	0.03	0.00	1.25	2.00	36.81	0.02	1.74
LIT-11	2.89	1.12	1.77	0.39	0.060	0.021	0.14	0.00	1.25	2.00	8.67	0.07	2.69
LIT-11	1.55	0.74	0.81	0.48	0.060	0.021	0.11	0.00	1.25	2.00	10.96	0.06	2.59
LIT-11	0.86	0.47	0.39	0.55	0.060	0.021	0.09	0.00	1.25	2.00	13.65	0.05	2.50
LIT-11	0.35	0.25	0.10	0.70	0.060	0.021	0.07	0.00	1.25	2.00	19.19	0.03	2.36
LIT-11	0.06	0.06	0.00	0.94	0.060	0.021	0.03	0.00	1.25	2.00	36.21	0.02	2.13
LIT-11	2.98	1.18	1.80	0.40	0.090	0.021	0.14	0.00	1.25	2.00	9.25	0.07	3.26
LIT-11	1.67	0.79	0.87	0.48	0.090	0.021	0.11	0.00	1.25	2.00	11.52	0.05	3.15
LIT-11	1.05	0.58	0.46	0.56	0.090	0.021	0.09	0.00	1.25	2.00	13.71	0.05	3.06
LIT-11	0.38	0.28	0.10	0.73	0.090	0.021	0.06	0.00	1.25	2.00	20.02	0.03	2.87
LIT-11	0.07	0.07	0.00	0.94	0.090	0.021	0.03	0.00	1.25	2.00	37.97	0.02	2.58
LIT-11	3.01	1.19	1.82	0.39	0.130	0.021	0.13	0.00	1.25	2.00	9.88	0.06	3.88
LIT-11	1.56	0.77	0.78	0.50	0.130	0.021	0.10	0.00	1.25	2.00	12.66	0.05	3.72
LIT-11	0.86	0.49	0.37	0.57	0.130	0.021	0.08	0.00	1.25	2.00	15.82	0.04	3.58
LIT-11	0.43	0.31	0.13	0.71	0.130	0.021	0.06	0.00	1.25	2.00	20.46	0.03	3.44
LIT-11	0.11	0.11	0.01	0.95	0.130	0.021	0.04	0.00	1.25	2.00	33.83	0.02	3.16
LIT-12	1.05	1.01	0.03	0.97	0.005	0.063	0.24	0.00	8.00	0.08	33.76	0.24	0.84
LIT-12	2.10	1.68	0.42	0.80	0.005	0.063	0.31	0.00	8.00	0.08	26.02	0.31	0.88
LIT-12	3.15	1.87	1.29	0.59	0.005	0.063	0.36	0.00	8.00	0.08	22.33	0.36	0.90
LIT-12	4.21	1.65	2.55	0.39	0.005	0.063	0.40	0.00	8.00	0.08	20.04	0.40	0.92
LIT-12	0.85	0.78	0.07	0.92	0.020	0.063	0.17	0.00	8.00	0.08	47.40	0.17	1.60
LIT-12	1.50	1.15	0.35	0.77	0.020	0.063	0.21	0.00	8.00	0.08	38.31	0.21	1.65
LIT-12	2.50	1.39	1.11	0.56	0.020	0.063	0.25	0.00	8.00	0.08	31.59	0.25	1.71
LIT-12	3.51	1.57	1.94	0.45	0.020	0.063	0.29	0.00	8.00	0.08	27.83	0.29	1.74
LIT-12	4.51	1.43	3.07	0.32	0.020	0.063	0.32	0.00	8.00	0.08	25.33	0.32	1.77
LIT-12	0.44	0.32	0.12	0.73	0.090	0.063	0.10	0.00	8.00	0.08	80.63	0.10	3.10
LIT-12	1.30	0.65	0.66	0.50	0.090	0.063	0.15	0.00	8.00	0.08	53.49	0.15	3.32
LIT-12	2.45	0.93	1.52	0.38	0.090	0.063	0.19	0.00	8.00	0.08	42.19	0.19	3.45
LIT-12	3.76	0.90	2.86	0.24	0.090	0.063	0.22	0.00	8.00	0.08	35.95	0.22	3.55
LIT-12	4.61	0.82	3.79	0.18	0.090	0.063	0.24	0.00	8.00	0.08	33.31	0.24	3.59
LIT-12	1.00	0.99	0.01	0.99	0.005	0.063	0.23	0.00	8.00	0.15	34.32	0.13	0.84
LIT-12	2.00	1.76	0.24	0.88	0.005	0.063	0.30	0.00	8.00	0.15	26.50	0.17	0.88
LIT-12	3.03	2.41	0.62	0.80	0.005	0.063	0.35	0.00	8.00	0.15	22.67	0.20	0.90
LIT-12	4.03	2.70	1.33	0.67	0.005	0.063	0.39	0.00	8.00	0.15	20.37	0.22	0.92
LIT-12	5.35	2.76	2.59	0.52	0.005	0.063	0.44	0.00	8.00	0.15	18.32	0.25	0.93
LIT-12	1.01	0.92	0.09	0.91	0.020	0.063	0.18	0.00	8.00	0.15	44.36	0.10	1.61
LIT-12	2.00	1.49	0.51	0.75	0.020	0.063	0.23	0.00	8.00	0.15	34.35	0.13	1.68

Continued on next page

Table 5: Literature-Derived Performance Data for Drop-Type Inlets — Continued

ID-CODE	Q_A	Q_I	Q_O	Q_R	S_0	S_x	d_a	h_b	L_I	W_I	L_R	W_R	Fr
LIT-12	3.02	1.95	1.08	0.64	0.020	0.063	0.27	0.00	8.00	0.15	29.43	0.16	1.73
LIT-12	4.02	2.20	1.82	0.55	0.020	0.063	0.30	0.00	8.00	0.15	26.45	0.17	1.76
LIT-12	5.32	2.30	3.02	0.43	0.020	0.063	0.34	0.00	8.00	0.15	23.81	0.19	1.79
LIT-12	1.00	0.67	0.33	0.67	0.090	0.063	0.14	0.00	8.00	0.15	58.99	0.08	3.26
LIT-12	2.00	1.05	0.96	0.52	0.090	0.063	0.18	0.00	8.00	0.15	45.55	0.10	3.41
LIT-12	3.06	1.21	1.85	0.39	0.090	0.063	0.21	0.00	8.00	0.15	38.84	0.12	3.50
LIT-12	4.04	1.15	2.89	0.28	0.090	0.063	0.23	0.00	8.00	0.15	34.99	0.13	3.56
LIT-12	5.15	1.21	3.94	0.24	0.090	0.063	0.25	0.00	8.00	0.15	31.94	0.14	3.62
LIT-12	1.40	1.32	0.08	0.94	0.005	0.063	0.26	0.00	8.00	0.21	30.27	0.11	0.86
LIT-12	2.40	2.07	0.33	0.86	0.005	0.063	0.32	0.00	8.00	0.21	24.74	0.13	0.89
LIT-12	3.51	2.68	0.82	0.77	0.005	0.063	0.37	0.00	8.00	0.21	21.46	0.15	0.91
LIT-12	4.51	3.02	1.49	0.67	0.005	0.063	0.41	0.00	8.00	0.21	19.53	0.16	0.93
LIT-12	0.87	0.76	0.11	0.88	0.020	0.063	0.17	0.00	8.00	0.21	46.92	0.07	1.60
LIT-12	1.90	1.46	0.44	0.77	0.020	0.063	0.23	0.00	8.00	0.21	35.04	0.09	1.68
LIT-12	3.00	2.08	0.93	0.69	0.020	0.063	0.27	0.00	8.00	0.21	29.50	0.11	1.73
LIT-12	3.96	2.31	1.64	0.58	0.020	0.063	0.30	0.00	8.00	0.21	26.60	0.12	1.76
LIT-12	5.01	1.31	3.70	0.26	0.020	0.063	0.33	0.00	8.00	0.21	24.35	0.13	1.78
LIT-12	1.00	0.69	0.31	0.69	0.090	0.063	0.14	0.00	8.00	0.21	58.99	0.05	3.26
LIT-12	2.00	1.04	0.96	0.52	0.090	0.063	0.18	0.00	8.00	0.21	45.56	0.07	3.41
LIT-12	3.01	1.31	1.70	0.43	0.090	0.063	0.20	0.00	8.00	0.21	39.09	0.08	3.50
LIT-12	4.01	1.40	2.60	0.35	0.090	0.063	0.23	0.00	8.00	0.21	35.10	0.09	3.56
LIT-12	5.00	1.42	3.58	0.28	0.090	0.063	0.25	0.00	8.00	0.21	32.30	0.10	3.61
LIT-12	0.55	0.51	0.04	0.92	0.005	0.031	0.14	0.00	8.00	0.08	55.88	0.14	0.78
LIT-12	1.50	1.07	0.43	0.71	0.005	0.031	0.21	0.00	8.00	0.08	38.38	0.21	0.83
LIT-12	2.70	1.46	1.25	0.54	0.005	0.031	0.26	0.00	8.00	0.08	30.78	0.26	0.86
LIT-12	3.81	1.32	2.49	0.35	0.005	0.031	0.30	0.00	8.00	0.08	27.06	0.30	0.88
LIT-12	4.61	1.16	3.45	0.25	0.005	0.031	0.32	0.00	8.00	0.08	25.20	0.32	0.89
LIT-12	0.50	0.38	0.11	0.77	0.020	0.031	0.11	0.00	8.00	0.08	75.32	0.11	1.48
LIT-12	1.30	0.79	0.51	0.60	0.020	0.031	0.15	0.00	8.00	0.08	52.52	0.15	1.57
LIT-12	2.40	1.02	1.38	0.42	0.020	0.031	0.19	0.00	8.00	0.08	41.72	0.19	1.63
LIT-12	3.56	1.09	2.46	0.31	0.020	0.031	0.22	0.00	8.00	0.08	36.01	0.22	1.67
LIT-12	4.76	0.90	3.85	0.19	0.020	0.031	0.25	0.00	8.00	0.08	32.29	0.25	1.70
LIT-12	0.35	0.18	0.17	0.51	0.090	0.031	0.07	0.00	8.00	0.08	113.63	0.07	2.92
LIT-12	0.90	0.39	0.52	0.43	0.090	0.031	0.10	0.00	8.00	0.08	79.85	0.10	3.11
LIT-12	1.80	0.47	1.33	0.26	0.090	0.031	0.13	0.00	8.00	0.08	61.65	0.13	3.24
LIT-12	2.70	0.45	2.25	0.17	0.090	0.031	0.15	0.00	8.00	0.08	52.93	0.15	3.32
LIT-12	3.76	0.34	3.42	0.09	0.090	0.031	0.17	0.00	8.00	0.08	46.75	0.17	3.39
LIT-12	4.76	0.18	4.58	0.04	0.090	0.031	0.19	0.00	8.00	0.08	42.80	0.19	3.44
LIT-12	0.51	0.49	0.02	0.96	0.005	0.031	0.14	0.00	8.00	0.15	57.60	0.08	0.77

Continued on next page

Table 5: Literature-Derived Performance Data for Drop-Type Inlets — Continued

ID-CODE	Q_A	Q_I	Q_O	Q_R	S_0	S_x	d_a	h_b	L_I	W_I	L_R	W_R	Fr
LIT-12	1.00	0.83	0.17	0.83	0.005	0.031	0.18	0.00	8.00	0.15	44.61	0.10	0.81
LIT-12	2.16	1.47	0.68	0.68	0.005	0.031	0.24	0.00	8.00	0.15	33.49	0.14	0.85
LIT-12	3.09	1.77	1.33	0.57	0.005	0.031	0.27	0.00	8.00	0.15	29.27	0.16	0.86
LIT-12	4.01	1.88	2.13	0.47	0.005	0.031	0.30	0.00	8.00	0.15	26.56	0.17	0.88
LIT-12	5.30	1.90	3.41	0.36	0.005	0.031	0.33	0.00	8.00	0.15	23.90	0.19	0.89
LIT-12	0.51	0.39	0.12	0.77	0.020	0.031	0.11	0.00	8.00	0.15	74.60	0.06	1.48
LIT-12	1.01	0.65	0.36	0.64	0.020	0.031	0.14	0.00	8.00	0.15	57.71	0.08	1.54
LIT-12	2.00	1.06	0.94	0.53	0.020	0.031	0.18	0.00	8.00	0.15	44.70	0.10	1.61
LIT-12	3.01	1.39	1.61	0.46	0.020	0.031	0.21	0.00	8.00	0.15	38.35	0.12	1.65
LIT-12	4.04	1.54	2.50	0.38	0.020	0.031	0.23	0.00	8.00	0.15	34.35	0.13	1.68
LIT-12	5.32	1.67	3.65	0.31	0.020	0.031	0.26	0.00	8.00	0.15	30.97	0.15	1.71
LIT-12	0.54	0.25	0.28	0.47	0.090	0.031	0.08	0.00	8.00	0.15	97.15	0.05	3.01
LIT-12	1.02	0.44	0.58	0.43	0.090	0.031	0.11	0.00	8.00	0.15	76.15	0.06	3.13
LIT-12	2.00	0.66	1.34	0.33	0.090	0.031	0.14	0.00	8.00	0.15	59.25	0.08	3.26
LIT-12	3.06	0.94	2.13	0.31	0.090	0.031	0.16	0.00	8.00	0.15	50.49	0.09	3.35
LIT-12	4.01	0.98	3.03	0.25	0.090	0.031	0.18	0.00	8.00	0.15	45.66	0.10	3.41
LIT-12	5.16	0.85	4.31	0.17	0.090	0.031	0.19	0.00	8.00	0.15	41.54	0.11	3.46
LIT-12	0.70	0.57	0.13	0.82	0.005	0.031	0.16	0.00	8.00	0.21	51.06	0.06	0.79
LIT-12	1.40	1.07	0.33	0.76	0.005	0.031	0.20	0.00	8.00	0.21	39.43	0.08	0.82
LIT-12	2.50	1.35	1.15	0.54	0.005	0.031	0.25	0.00	8.00	0.21	31.70	0.10	0.85
LIT-12	3.61	1.75	1.86	0.48	0.005	0.031	0.29	0.00	8.00	0.21	27.62	0.12	0.87
LIT-12	4.81	2.09	2.72	0.43	0.005	0.031	0.32	0.00	8.00	0.21	24.79	0.13	0.89
LIT-12	0.50	0.37	0.13	0.74	0.020	0.031	0.11	0.00	8.00	0.21	75.04	0.04	1.48
LIT-12	1.00	0.65	0.35	0.65	0.020	0.031	0.14	0.00	8.00	0.21	57.86	0.06	1.54
LIT-12	1.90	0.99	0.91	0.52	0.020	0.031	0.18	0.00	8.00	0.21	45.57	0.07	1.61
LIT-12	3.01	1.18	1.83	0.39	0.020	0.031	0.21	0.00	8.00	0.21	38.35	0.08	1.65
LIT-12	4.01	1.47	2.54	0.37	0.020	0.031	0.23	0.00	8.00	0.21	34.43	0.09	1.68
LIT-12	5.00	1.53	3.47	0.31	0.020	0.031	0.25	0.00	8.00	0.21	31.70	0.10	1.71
LIT-12	0.24	0.14	0.10	0.59	0.090	0.031	0.06	0.00	8.00	0.21	131.05	0.02	2.86
LIT-12	0.56	0.32	0.25	0.56	0.090	0.031	0.08	0.00	8.00	0.21	95.24	0.03	3.02
LIT-12	1.40	0.48	0.92	0.34	0.090	0.031	0.12	0.00	8.00	0.21	67.71	0.05	3.19
LIT-12	2.18	0.61	1.58	0.28	0.090	0.031	0.14	0.00	8.00	0.21	57.33	0.06	3.28
LIT-12	3.87	0.91	2.96	0.23	0.090	0.031	0.17	0.00	8.00	0.21	46.25	0.07	3.40
LIT-12	5.00	0.91	4.10	0.18	0.090	0.031	0.19	0.00	8.00	0.21	42.01	0.08	3.45
LIT-12	0.35	0.27	0.08	0.78	0.005	0.016	0.09	0.00	8.00	0.08	85.49	0.09	0.72
LIT-12	0.80	0.55	0.25	0.69	0.005	0.016	0.13	0.00	8.00	0.08	62.72	0.13	0.76
LIT-12	1.70	0.82	0.88	0.48	0.005	0.016	0.17	0.00	8.00	0.08	47.38	0.17	0.80
LIT-12	2.69	1.00	1.70	0.37	0.005	0.016	0.20	0.00	8.00	0.08	39.87	0.20	0.82
LIT-12	3.76	1.15	2.61	0.31	0.005	0.016	0.23	0.00	8.00	0.08	35.18	0.23	0.84

Continued on next page

Table 5: Literature-Derived Performance Data for Drop-Type Inlets — Continued

ID-CODE	Q_A	Q_I	Q_O	Q_R	S_0	S_x	d_a	h_b	L_I	W_I	L_R	W_R	Fr
LIT-12	4.61	1.16	3.46	0.25	0.005	0.016	0.25	0.00	8.00	0.08	32.59	0.25	0.85
LIT-12	0.50	0.29	0.21	0.59	0.020	0.016	0.08	0.00	8.00	0.08	97.38	0.08	1.42
LIT-12	1.21	0.44	0.77	0.37	0.020	0.016	0.11	0.00	8.00	0.08	69.89	0.11	1.50
LIT-12	2.40	0.74	1.66	0.31	0.020	0.016	0.15	0.00	8.00	0.08	53.97	0.15	1.56
LIT-12	3.56	0.75	2.82	0.21	0.020	0.016	0.17	0.00	8.00	0.08	46.55	0.17	1.60
LIT-12	4.76	0.79	3.98	0.17	0.020	0.016	0.19	0.00	8.00	0.08	41.75	0.19	1.63
LIT-12	0.35	0.14	0.21	0.39	0.090	0.016	0.05	0.00	8.00	0.08	147.34	0.05	2.80
LIT-12	1.01	0.30	0.71	0.30	0.090	0.016	0.08	0.00	8.00	0.08	99.10	0.08	2.99
LIT-12	1.90	0.45	1.45	0.24	0.090	0.016	0.10	0.00	8.00	0.08	78.07	0.10	3.12
LIT-12	2.70	0.49	2.21	0.18	0.090	0.016	0.12	0.00	8.00	0.08	68.49	0.12	3.18
LIT-12	3.76	0.54	3.22	0.14	0.090	0.016	0.13	0.00	8.00	0.08	60.47	0.13	3.25
LIT-12	0.52	0.37	0.14	0.73	0.005	0.016	0.11	0.00	8.00	0.15	74.09	0.06	0.74
LIT-12	1.01	0.63	0.38	0.62	0.005	0.016	0.14	0.00	8.00	0.15	57.55	0.08	0.77
LIT-12	2.01	1.03	0.98	0.51	0.005	0.016	0.18	0.00	8.00	0.15	44.51	0.10	0.81
LIT-12	3.02	1.36	1.66	0.45	0.005	0.016	0.21	0.00	8.00	0.15	38.20	0.12	0.83
LIT-12	3.98	1.56	2.42	0.39	0.005	0.016	0.23	0.00	8.00	0.15	34.44	0.13	0.84
LIT-12	5.36	1.84	3.52	0.34	0.005	0.016	0.26	0.00	8.00	0.15	30.81	0.15	0.86
LIT-12	0.51	0.27	0.24	0.53	0.020	0.016	0.08	0.00	8.00	0.15	96.80	0.05	1.42
LIT-12	1.01	0.45	0.56	0.45	0.020	0.016	0.11	0.00	8.00	0.15	74.61	0.06	1.48
LIT-12	2.00	0.69	1.31	0.35	0.020	0.016	0.14	0.00	8.00	0.15	57.76	0.08	1.54
LIT-12	3.02	0.91	2.11	0.30	0.020	0.016	0.16	0.00	8.00	0.15	49.54	0.09	1.58
LIT-12	4.01	1.04	2.97	0.26	0.020	0.016	0.18	0.00	8.00	0.15	44.54	0.10	1.61
LIT-12	5.31	1.11	4.20	0.21	0.020	0.016	0.20	0.00	8.00	0.15	40.07	0.11	1.64
LIT-12	0.58	0.16	0.42	0.27	0.090	0.016	0.07	0.00	8.00	0.15	121.71	0.04	2.89
LIT-12	1.02	0.26	0.76	0.26	0.090	0.016	0.08	0.00	8.00	0.15	98.81	0.05	3.00
LIT-12	2.01	0.42	1.59	0.21	0.090	0.016	0.10	0.00	8.00	0.15	76.57	0.06	3.12
LIT-12	3.06	0.57	2.49	0.19	0.090	0.016	0.12	0.00	8.00	0.15	65.32	0.07	3.21
LIT-12	4.03	0.67	3.36	0.17	0.090	0.016	0.14	0.00	8.00	0.15	58.95	0.08	3.27
LIT-12	5.17	0.59	4.58	0.11	0.090	0.016	0.15	0.00	8.00	0.15	53.69	0.09	3.32
LIT-12	0.74	0.50	0.23	0.68	0.005	0.016	0.12	0.00	8.00	0.21	64.82	0.05	0.76
LIT-12	1.38	0.68	0.70	0.49	0.005	0.016	0.16	0.00	8.00	0.21	51.19	0.06	0.79
LIT-12	2.52	1.19	1.32	0.47	0.005	0.016	0.20	0.00	8.00	0.21	40.90	0.08	0.82
LIT-12	3.56	1.42	2.14	0.40	0.005	0.016	0.22	0.00	8.00	0.21	35.92	0.09	0.84
LIT-12	4.51	1.46	3.05	0.32	0.005	0.016	0.24	0.00	8.00	0.21	32.86	0.10	0.85
LIT-12	5.00	1.41	3.59	0.28	0.005	0.016	0.25	0.00	8.00	0.21	31.62	0.10	0.85
LIT-12	0.74	0.39	0.34	0.53	0.020	0.016	0.10	0.00	8.00	0.21	84.08	0.04	1.45
LIT-12	0.98	0.44	0.54	0.44	0.020	0.016	0.11	0.00	8.00	0.21	75.57	0.04	1.48
LIT-12	2.00	0.64	1.36	0.32	0.020	0.016	0.14	0.00	8.00	0.21	57.78	0.06	1.54
LIT-12	3.01	0.81	2.20	0.27	0.020	0.016	0.16	0.00	8.00	0.21	49.63	0.06	1.58

Continued on next page

Table 5: Literature-Derived Performance Data for Drop-Type Inlets — Continued

ID-CODE	Q_A	Q_I	Q_O	Q_R	S_0	S_x	d_a	h_b	L_I	W_I	L_R	W_R	Fr
LIT-12	4.01	0.96	3.04	0.24	0.020	0.016	0.18	0.00	8.00	0.21	44.56	0.07	1.61
LIT-12	5.00	1.01	3.99	0.20	0.020	0.016	0.20	0.00	8.00	0.21	41.00	0.08	1.64
LIT-12	0.31	0.09	0.22	0.30	0.090	0.016	0.05	0.00	8.00	0.21	153.64	0.02	2.78
LIT-12	0.81	0.22	0.59	0.27	0.090	0.016	0.07	0.00	8.00	0.21	107.66	0.03	2.95
LIT-12	1.57	0.32	1.26	0.20	0.090	0.016	0.10	0.00	8.00	0.21	83.87	0.04	3.08
LIT-12	3.17	0.58	2.59	0.18	0.090	0.016	0.12	0.00	8.00	0.21	64.52	0.05	3.22
LIT-12	4.76	0.75	4.01	0.16	0.090	0.016	0.14	0.00	8.00	0.21	55.39	0.06	3.30
LIT-12	2.70	2.61	0.08	0.97	0.090	0.063	0.20	0.00	24.00	0.08	122.18	0.20	3.47
LIT-12	3.91	3.37	0.54	0.86	0.090	0.063	0.23	0.00	24.00	0.08	106.32	0.23	3.55
LIT-12	4.75	3.49	1.27	0.73	0.090	0.063	0.24	0.00	24.00	0.08	98.76	0.24	3.60
LIT-12	5.24	3.58	1.67	0.68	0.090	0.063	0.25	0.00	24.00	0.08	95.20	0.25	3.62
LIT-12	5.25	5.25	0.00	1.00	0.020	0.063	0.33	0.00	24.00	0.15	71.80	0.19	1.79
LIT-12	5.31	5.30	0.01	1.00	0.020	0.063	0.34	0.00	24.00	0.15	71.45	0.19	1.79
LIT-12	2.50	2.44	0.06	0.98	0.090	0.063	0.19	0.00	24.00	0.15	125.68	0.11	3.46
LIT-12	3.01	2.87	0.14	0.95	0.090	0.063	0.20	0.00	24.00	0.15	117.17	0.12	3.50
LIT-12	3.57	3.15	0.42	0.88	0.090	0.063	0.22	0.00	24.00	0.15	109.93	0.12	3.53
LIT-12	4.03	3.02	1.01	0.75	0.090	0.063	0.23	0.00	24.00	0.15	105.11	0.13	3.56
LIT-12	4.54	3.11	1.43	0.68	0.090	0.063	0.24	0.00	24.00	0.15	100.48	0.14	3.59
LIT-12	5.15	3.17	1.98	0.62	0.090	0.063	0.25	0.00	24.00	0.15	95.85	0.14	3.62
LIT-12	2.59	2.51	0.07	0.97	0.090	0.063	0.19	0.00	24.00	0.21	124.05	0.08	3.46
LIT-12	3.39	3.23	0.16	0.95	0.090	0.063	0.21	0.00	24.00	0.21	112.10	0.09	3.52
LIT-12	4.29	3.85	0.44	0.90	0.090	0.063	0.23	0.00	24.00	0.21	102.60	0.09	3.58
LIT-12	5.04	4.07	0.97	0.81	0.090	0.063	0.25	0.00	24.00	0.21	96.61	0.10	3.61
LIT-12	3.34	3.32	0.02	0.99	0.005	0.031	0.28	0.00	24.00	0.08	85.27	0.28	0.87
LIT-12	4.47	4.26	0.22	0.95	0.005	0.031	0.31	0.00	24.00	0.08	76.43	0.31	0.88
LIT-12	5.38	4.72	0.67	0.88	0.005	0.031	0.34	0.00	24.00	0.08	71.32	0.34	0.90
LIT-12	1.97	1.91	0.06	0.97	0.020	0.031	0.18	0.00	24.00	0.08	134.73	0.18	1.61
LIT-12	3.13	2.96	0.18	0.94	0.020	0.031	0.21	0.00	24.00	0.08	113.28	0.21	1.66
LIT-12	4.03	3.59	0.44	0.89	0.020	0.031	0.23	0.00	24.00	0.08	103.13	0.23	1.68
LIT-12	5.13	3.61	1.52	0.70	0.020	0.031	0.25	0.00	24.00	0.08	94.18	0.25	1.71
LIT-12	0.48	0.39	0.09	0.81	0.090	0.031	0.08	0.00	24.00	0.08	303.77	0.08	2.98
LIT-12	1.28	0.98	0.31	0.76	0.090	0.031	0.11	0.00	24.00	0.08	209.94	0.11	3.17
LIT-12	2.38	1.55	0.83	0.65	0.090	0.031	0.14	0.00	24.00	0.08	166.56	0.14	3.30
LIT-12	3.54	1.91	1.62	0.54	0.090	0.031	0.17	0.00	24.00	0.08	143.56	0.17	3.38
LIT-12	4.59	1.84	2.74	0.40	0.090	0.031	0.18	0.00	24.00	0.08	130.20	0.18	3.44
LIT-12	4.41	4.39	0.02	0.99	0.005	0.031	0.31	0.00	24.00	0.15	76.85	0.18	0.88
LIT-12	5.01	4.95	0.05	0.99	0.005	0.031	0.33	0.00	24.00	0.15	73.27	0.19	0.89
LIT-12	2.75	2.72	0.03	0.99	0.020	0.031	0.20	0.00	24.00	0.15	118.92	0.12	1.64
LIT-12	2.76	2.70	0.06	0.98	0.020	0.031	0.20	0.00	24.00	0.15	118.87	0.12	1.64

Continued on next page

Table 5: Literature-Derived Performance Data for Drop-Type Inlets — Continued

ID-CODE	Q_A	Q_I	Q_O	Q_R	S_0	S_x	d_a	h_b	L_I	W_I	L_R	W_R	Fr
LIT-12	3.00	2.93	0.07	0.98	0.020	0.031	0.21	0.00	24.00	0.15	115.21	0.12	1.65
LIT-12	3.20	3.05	0.14	0.96	0.020	0.031	0.21	0.00	24.00	0.15	112.45	0.12	1.66
LIT-12	4.06	3.73	0.33	0.92	0.020	0.031	0.23	0.00	24.00	0.15	102.79	0.13	1.68
LIT-12	5.31	4.53	0.78	0.85	0.020	0.031	0.26	0.00	24.00	0.15	92.97	0.15	1.71
LIT-12	0.53	0.49	0.04	0.93	0.090	0.031	0.08	0.00	24.00	0.15	292.67	0.05	3.00
LIT-12	1.09	0.92	0.18	0.84	0.090	0.031	0.11	0.00	24.00	0.15	223.09	0.06	3.14
LIT-12	2.00	1.54	0.46	0.77	0.090	0.031	0.14	0.00	24.00	0.15	177.71	0.08	3.26
LIT-12	3.00	2.03	0.97	0.68	0.090	0.031	0.16	0.00	24.00	0.15	152.69	0.09	3.35
LIT-12	4.03	2.41	1.62	0.60	0.090	0.031	0.18	0.00	24.00	0.15	136.68	0.10	3.41
LIT-12	5.15	2.59	2.56	0.50	0.090	0.031	0.19	0.00	24.00	0.15	124.64	0.11	3.46
LIT-12	2.95	2.86	0.09	0.97	0.020	0.031	0.21	0.00	24.00	0.21	115.94	0.08	1.65
LIT-12	4.26	3.83	0.44	0.90	0.020	0.031	0.24	0.00	24.00	0.21	100.93	0.10	1.69
LIT-12	5.26	4.39	0.86	0.84	0.020	0.031	0.26	0.00	24.00	0.21	93.31	0.10	1.71
LIT-12	1.71	1.33	0.38	0.78	0.090	0.031	0.13	0.00	24.00	0.21	188.71	0.05	3.23
LIT-12	2.80	1.93	0.88	0.69	0.090	0.031	0.15	0.00	24.00	0.21	156.63	0.06	3.33
LIT-12	3.92	2.42	1.50	0.62	0.090	0.031	0.17	0.00	24.00	0.21	138.17	0.07	3.40
LIT-12	5.01	2.64	2.37	0.53	0.090	0.031	0.19	0.00	24.00	0.21	125.98	0.08	3.46
LIT-12	1.31	1.28	0.03	0.98	0.005	0.016	0.15	0.00	24.00	0.08	156.83	0.15	0.79
LIT-12	2.68	2.48	0.19	0.93	0.005	0.016	0.20	0.00	24.00	0.08	119.90	0.20	0.82
LIT-12	3.68	3.18	0.50	0.86	0.005	0.016	0.23	0.00	24.00	0.08	106.40	0.23	0.84
LIT-12	4.72	3.76	0.96	0.80	0.005	0.016	0.25	0.00	24.00	0.08	96.92	0.25	0.85
LIT-12	5.36	4.12	1.24	0.77	0.005	0.016	0.26	0.00	24.00	0.08	92.41	0.26	0.86
LIT-12	0.58	0.52	0.06	0.90	0.020	0.016	0.09	0.00	24.00	0.08	276.62	0.09	1.43
LIT-12	1.28	1.10	0.18	0.86	0.020	0.016	0.12	0.00	24.00	0.08	204.98	0.12	1.50
LIT-12	2.37	1.81	0.56	0.76	0.020	0.016	0.15	0.00	24.00	0.08	162.66	0.15	1.56
LIT-12	3.53	2.50	1.04	0.71	0.020	0.016	0.17	0.00	24.00	0.08	140.15	0.17	1.60
LIT-12	4.58	3.01	1.57	0.66	0.020	0.016	0.19	0.00	24.00	0.08	127.10	0.19	1.63
LIT-12	0.48	0.26	0.22	0.54	0.090	0.016	0.06	0.00	24.00	0.08	393.31	0.06	2.86
LIT-12	1.33	0.60	0.73	0.45	0.090	0.016	0.09	0.00	24.00	0.08	267.97	0.09	3.05
LIT-12	2.38	0.93	1.44	0.39	0.090	0.016	0.11	0.00	24.00	0.08	215.49	0.11	3.16
LIT-12	3.59	1.20	2.39	0.33	0.090	0.016	0.13	0.00	24.00	0.08	184.69	0.13	3.24
LIT-12	4.74	1.50	3.23	0.32	0.090	0.016	0.14	0.00	24.00	0.08	166.42	0.14	3.30
LIT-12	1.13	1.12	0.01	0.99	0.005	0.016	0.15	0.00	24.00	0.15	165.44	0.08	0.78
LIT-12	2.05	1.99	0.06	0.97	0.005	0.016	0.18	0.00	24.00	0.15	132.56	0.10	0.81
LIT-12	3.07	2.84	0.23	0.92	0.005	0.016	0.21	0.00	24.00	0.15	113.83	0.12	0.83
LIT-12	4.02	3.53	0.49	0.88	0.005	0.016	0.23	0.00	24.00	0.15	102.97	0.13	0.84
LIT-12	5.34	4.44	0.91	0.83	0.005	0.016	0.26	0.00	24.00	0.15	92.51	0.15	0.86
LIT-12	0.74	0.66	0.09	0.88	0.020	0.016	0.10	0.00	24.00	0.15	251.74	0.05	1.45
LIT-12	1.01	0.87	0.14	0.86	0.020	0.016	0.11	0.00	24.00	0.15	224.50	0.06	1.48

Continued on next page

Table 5: Literature-Derived Performance Data for Drop-Type Inlets — Continued

ID-CODE	Q_A	Q_I	Q_O	Q_R	S_0	S_x	d_a	h_b	L_I	W_I	L_R	W_R	Fr
LIT-12	2.10	1.69	0.41	0.80	0.020	0.016	0.14	0.00	24.00	0.15	170.19	0.08	1.55
LIT-12	3.01	2.26	0.75	0.75	0.020	0.016	0.16	0.00	24.00	0.15	148.77	0.09	1.58
LIT-12	4.03	2.86	1.17	0.71	0.020	0.016	0.18	0.00	24.00	0.15	133.42	0.10	1.61
LIT-12	5.31	3.51	1.80	0.66	0.020	0.016	0.20	0.00	24.00	0.15	120.28	0.11	1.64
LIT-12	0.48	0.28	0.20	0.59	0.090	0.016	0.06	0.00	24.00	0.15	392.08	0.03	2.86
LIT-12	1.00	0.56	0.45	0.56	0.090	0.016	0.08	0.00	24.00	0.15	297.76	0.05	2.99
LIT-12	2.03	0.99	1.04	0.49	0.090	0.016	0.11	0.00	24.00	0.15	228.57	0.06	3.13
LIT-12	3.32	1.26	2.06	0.38	0.090	0.016	0.13	0.00	24.00	0.15	190.26	0.07	3.23
LIT-12	4.12	1.48	2.65	0.36	0.090	0.016	0.14	0.00	24.00	0.15	175.30	0.08	3.27
LIT-12	5.13	1.87	3.26	0.36	0.090	0.016	0.15	0.00	24.00	0.15	161.51	0.08	3.31
LIT-12	1.01	0.99	0.01	0.99	0.005	0.016	0.14	0.00	24.00	0.21	173.10	0.06	0.77
LIT-12	2.00	1.88	0.12	0.94	0.005	0.016	0.18	0.00	24.00	0.21	133.77	0.07	0.81
LIT-12	3.00	2.70	0.30	0.90	0.005	0.016	0.21	0.00	24.00	0.21	114.92	0.08	0.83
LIT-12	4.01	3.50	0.51	0.87	0.005	0.016	0.23	0.00	24.00	0.21	103.07	0.09	0.84
LIT-12	5.01	4.19	0.82	0.84	0.005	0.016	0.25	0.00	24.00	0.21	94.80	0.10	0.85
LIT-12	1.01	0.88	0.13	0.87	0.020	0.016	0.11	0.00	24.00	0.21	224.50	0.04	1.48
LIT-12	2.00	1.56	0.44	0.78	0.020	0.016	0.14	0.00	24.00	0.21	173.39	0.06	1.54
LIT-12	3.00	2.12	0.88	0.71	0.020	0.016	0.16	0.00	24.00	0.21	149.03	0.06	1.58
LIT-12	4.01	2.80	1.21	0.70	0.020	0.016	0.18	0.00	24.00	0.21	133.63	0.07	1.61
LIT-12	5.01	3.27	1.74	0.65	0.020	0.016	0.20	0.00	24.00	0.21	122.94	0.08	1.64
LIT-12	1.00	0.53	0.47	0.53	0.090	0.016	0.08	0.00	24.00	0.21	297.98	0.03	2.99
LIT-12	2.00	0.93	1.07	0.47	0.090	0.016	0.10	0.00	24.00	0.21	229.85	0.04	3.13
LIT-12	3.01	1.30	1.70	0.43	0.090	0.016	0.12	0.00	24.00	0.21	197.39	0.05	3.21
LIT-12	4.01	1.51	2.50	0.38	0.090	0.016	0.14	0.00	24.00	0.21	177.20	0.05	3.26
LIT-12	5.00	1.72	3.28	0.34	0.090	0.016	0.15	0.00	24.00	0.21	163.05	0.06	3.31
LIT-13	4.77	4.77	0.00	1.00	0.002	0.063	0.53	0.53	1.25	2.00	2.34	0.27	0.50
LIT-13	6.39	6.39	0.00	1.00	0.002	0.063	0.63	0.63	1.25	2.00	1.99	0.31	0.45
LIT-13	7.59	7.59	0.00	1.00	0.002	0.063	0.73	0.73	1.25	2.00	1.72	0.36	0.37
LIT-13	8.90	8.90	0.00	1.00	0.002	0.063	0.85	0.85	1.25	2.00	1.48	0.42	0.30
LIT-13	10.34	10.34	0.00	1.00	0.002	0.063	1.01	1.01	1.25	2.00	1.24	0.50	0.22
LIT-13	5.28	5.28	0.00	1.00	0.002	0.063	0.50	0.50	1.25	2.67	2.50	0.19	0.66
LIT-13	7.09	7.09	0.00	1.00	0.002	0.063	0.61	0.61	1.25	2.67	2.06	0.23	0.54
LIT-13	9.02	9.02	0.00	1.00	0.002	0.063	0.72	0.72	1.25	2.67	1.74	0.27	0.45
LIT-13	10.81	10.81	0.00	1.00	0.002	0.063	0.85	0.85	1.25	2.67	1.48	0.32	0.36
LIT-13	12.76	12.76	0.00	1.00	0.002	0.063	0.99	0.99	1.25	2.67	1.26	0.37	0.29
LIT-13	4.78	4.78	0.00	1.00	0.002	0.063	0.47	0.47	2.00	2.00	4.26	0.23	0.70
LIT-13	7.26	7.26	0.00	1.00	0.002	0.063	0.59	0.59	2.00	2.00	3.41	0.29	0.61
LIT-13	9.60	9.60	0.00	1.00	0.002	0.063	0.69	0.69	2.00	2.00	2.89	0.35	0.53
LIT-13	11.72	11.72	0.00	1.00	0.002	0.063	0.83	0.83	2.00	2.00	2.42	0.41	0.42

Continued on next page

Table 5: Literature-Derived Performance Data for Drop-Type Inlets — Continued

ID-CODE	Q_A	Q_I	Q_O	Q_R	S_0	S_x	d_a	h_b	L_I	W_I	L_R	W_R	Fr
LIT-13	14.23	14.23	0.00	1.00	0.002	0.063	1.01	1.01	2.00	2.00	1.97	0.51	0.30
LIT-13	3.64	3.64	0.00	1.00	0.002	0.063	0.43	0.43	2.00	4.00	4.65	0.11	0.66
LIT-13	10.84	10.84	0.00	1.00	0.002	0.063	0.61	0.61	2.00	4.00	3.26	0.15	0.81
LIT-13	16.66	16.66	0.00	1.00	0.002	0.063	0.82	0.82	2.00	4.00	2.45	0.20	0.61
LIT-13	22.34	22.34	0.00	1.00	0.002	0.063	0.99	0.99	2.00	4.00	2.02	0.25	0.50
LIT-13	28.41	28.41	0.00	1.00	0.002	0.063	1.18	1.18	2.00	4.00	1.69	0.30	0.41
LIT-13	3.75	3.75	0.00	1.00	0.002	0.063	0.37	0.37	3.00	2.00	8.07	0.19	0.98
LIT-13	10.84	10.84	0.00	1.00	0.002	0.063	0.63	0.63	3.00	2.00	4.74	0.32	0.75
LIT-13	16.63	16.63	0.00	1.00	0.002	0.063	0.84	0.84	3.00	2.00	3.58	0.42	0.57
LIT-13	19.64	19.64	0.00	1.00	0.002	0.063	0.96	0.96	3.00	2.00	3.11	0.48	0.47
LIT-13	22.33	22.33	0.00	1.00	0.002	0.063	1.15	1.15	3.00	2.00	2.62	0.57	0.35
LIT-13	4.94	4.94	0.00	1.00	0.002	0.063	0.41	0.41	3.00	4.00	7.26	0.10	0.99
LIT-13	10.78	10.78	0.00	1.00	0.002	0.063	0.59	0.59	3.00	4.00	5.12	0.15	0.91
LIT-13	16.63	16.63	0.00	1.00	0.002	0.063	0.76	0.76	3.00	4.00	3.93	0.19	0.72
LIT-13	22.33	22.33	0.00	1.00	0.002	0.063	0.91	0.91	3.00	4.00	3.29	0.23	0.62
LIT-13	28.36	28.36	0.00	1.00	0.002	0.063	1.05	1.05	3.00	4.00	2.87	0.26	0.56
LIT-13	4.85	4.85	0.00	1.00	0.002	0.042	0.52	0.52	1.25	2.00	2.40	0.26	0.37
LIT-13	6.51	6.51	0.00	1.00	0.002	0.042	0.62	0.62	1.25	2.00	2.01	0.31	0.31
LIT-13	7.70	7.70	0.00	1.00	0.002	0.042	0.72	0.72	1.25	2.00	1.74	0.36	0.26
LIT-13	8.98	8.98	0.00	1.00	0.002	0.042	0.83	0.83	1.25	2.00	1.50	0.42	0.21
LIT-13	10.28	10.28	0.00	1.00	0.002	0.042	1.00	1.00	1.25	2.00	1.25	0.50	0.15
LIT-13	5.28	5.28	0.00	1.00	0.002	0.042	0.49	0.49	1.25	2.67	2.57	0.18	0.47
LIT-13	7.06	7.06	0.00	1.00	0.002	0.042	0.60	0.60	1.25	2.67	2.10	0.22	0.38
LIT-13	8.91	8.91	0.00	1.00	0.002	0.042	0.69	0.69	1.25	2.67	1.81	0.26	0.33
LIT-13	10.87	10.87	0.00	1.00	0.002	0.042	0.82	0.82	1.25	2.67	1.53	0.31	0.27
LIT-13	12.88	12.88	0.00	1.00	0.002	0.042	0.98	0.98	1.25	2.67	1.27	0.37	0.20
LIT-13	4.81	4.81	0.00	1.00	0.002	0.042	0.46	0.46	2.00	2.00	4.37	0.23	0.50
LIT-13	7.37	7.37	0.00	1.00	0.002	0.042	0.57	0.57	2.00	2.00	3.51	0.28	0.45
LIT-13	9.57	9.57	0.00	1.00	0.002	0.042	0.68	0.68	2.00	2.00	2.94	0.34	0.37
LIT-13	11.72	11.72	0.00	1.00	0.002	0.042	0.81	0.81	2.00	2.00	2.46	0.41	0.29
LIT-13	14.29	14.29	0.00	1.00	0.002	0.042	1.00	1.00	2.00	2.00	2.00	0.50	0.21
LIT-13	4.84	4.84	0.00	1.00	0.002	0.042	0.39	0.39	2.00	4.00	5.18	0.10	0.77
LIT-13	10.75	10.75	0.00	1.00	0.002	0.042	0.60	0.60	2.00	4.00	3.32	0.15	0.57
LIT-13	16.55	16.55	0.00	1.00	0.002	0.042	0.80	0.80	2.00	4.00	2.49	0.20	0.42
LIT-13	22.38	22.38	0.00	1.00	0.002	0.042	0.97	0.97	2.00	4.00	2.05	0.24	0.35
LIT-13	28.50	28.50	0.00	1.00	0.002	0.042	1.17	1.17	2.00	4.00	1.72	0.29	0.29
LIT-13	4.47	4.47	0.00	1.00	0.002	0.042	0.34	0.34	3.00	2.00	8.82	0.17	0.98
LIT-13	9.33	9.33	0.00	1.00	0.002	0.042	0.55	0.55	3.00	2.00	5.43	0.28	0.61
LIT-13	13.73	13.73	0.00	1.00	0.002	0.042	0.72	0.72	3.00	2.00	4.17	0.36	0.46

Continued on next page

Table 5: Literature-Derived Performance Data for Drop-Type Inlets — Continued

ID-CODE	Q_A	Q_I	Q_O	Q_R	S_0	S_x	d_a	h_b	L_I	W_I	L_R	W_R	Fr
LIT-13	18.34	18.34	0.00	1.00	0.002	0.042	0.88	0.88	3.00	2.00	3.43	0.44	0.38
LIT-13	22.77	22.77	0.00	1.00	0.002	0.042	1.11	1.11	3.00	2.00	2.70	0.56	0.26
LIT-13	5.63	5.63	0.00	1.00	0.002	0.042	0.36	0.36	3.00	4.00	8.38	0.09	1.08
LIT-13	10.84	10.84	0.00	1.00	0.002	0.042	0.56	0.56	3.00	4.00	5.39	0.14	0.69
LIT-13	16.56	16.56	0.00	1.00	0.002	0.042	0.73	0.73	3.00	4.00	4.13	0.18	0.54
LIT-13	22.44	22.44	0.00	1.00	0.002	0.042	0.86	0.86	3.00	4.00	3.48	0.22	0.48
LIT-13	28.50	28.50	0.00	1.00	0.002	0.042	1.02	1.02	3.00	4.00	2.94	0.26	0.40
LIT-13	4.84	4.84	0.00	1.00	0.002	0.021	0.54	0.54	1.25	2.00	2.32	0.27	0.17
LIT-13	6.38	6.38	0.00	1.00	0.002	0.021	0.62	0.62	1.25	2.00	2.02	0.31	0.16
LIT-13	7.69	7.69	0.00	1.00	0.002	0.021	0.71	0.71	1.25	2.00	1.76	0.36	0.13
LIT-13	8.85	8.85	0.00	1.00	0.002	0.021	0.82	0.82	1.25	2.00	1.53	0.41	0.11
LIT-13	10.26	10.26	0.00	1.00	0.002	0.021	0.99	0.99	1.25	2.00	1.26	0.49	0.08
LIT-13	5.12	5.12	0.00	1.00	0.002	0.021	0.48	0.48	1.25	2.67	2.61	0.18	0.24
LIT-13	7.13	7.13	0.00	1.00	0.002	0.021	0.59	0.59	1.25	2.67	2.12	0.22	0.20
LIT-13	8.92	8.92	0.00	1.00	0.002	0.021	0.70	0.70	1.25	2.67	1.77	0.26	0.16
LIT-13	10.76	10.76	0.00	1.00	0.002	0.021	0.82	0.82	1.25	2.67	1.53	0.31	0.13
LIT-13	12.82	12.82	0.00	1.00	0.002	0.021	0.96	0.96	1.25	2.67	1.31	0.36	0.11
LIT-13	4.83	4.83	0.00	1.00	0.002	0.021	0.45	0.45	2.00	2.00	4.49	0.22	0.27
LIT-13	7.33	7.33	0.00	1.00	0.002	0.021	0.55	0.55	2.00	2.00	3.66	0.27	0.24
LIT-13	9.55	9.55	0.00	1.00	0.002	0.021	0.66	0.66	2.00	2.00	3.01	0.33	0.19
LIT-13	11.72	11.72	0.00	1.00	0.002	0.021	0.80	0.80	2.00	2.00	2.50	0.40	0.15
LIT-13	14.37	14.37	0.00	1.00	0.002	0.021	1.00	1.00	2.00	2.00	2.00	0.50	0.11
LIT-13	4.97	4.97	0.00	1.00	0.002	0.021	0.37	0.37	2.00	4.00	5.40	0.09	0.44
LIT-13	10.84	10.84	0.00	1.00	0.002	0.021	0.59	0.59	2.00	4.00	3.41	0.15	0.30
LIT-13	16.50	16.50	0.00	1.00	0.002	0.021	0.78	0.78	2.00	4.00	2.57	0.19	0.23
LIT-13	22.40	22.40	0.00	1.00	0.002	0.021	0.95	0.95	2.00	4.00	2.11	0.24	0.19
LIT-13	4.91	4.91	0.00	1.00	0.002	0.021	0.39	0.39	3.00	2.00	7.76	0.19	0.39
LIT-13	8.79	8.79	0.00	1.00	0.002	0.021	0.52	0.52	3.00	2.00	5.76	0.26	0.33
LIT-13	12.73	12.73	0.00	1.00	0.002	0.021	0.66	0.66	3.00	2.00	4.56	0.33	0.27
LIT-13	16.49	16.49	0.00	1.00	0.002	0.021	0.80	0.80	3.00	2.00	3.76	0.40	0.21
LIT-13	20.43	20.43	0.00	1.00	0.002	0.021	0.97	0.97	3.00	2.00	3.11	0.48	0.16
LIT-13	4.94	4.94	0.00	1.00	0.002	0.021	0.35	0.35	3.00	4.00	8.48	0.09	0.49
LIT-13	10.81	10.81	0.00	1.00	0.002	0.021	0.54	0.54	3.00	4.00	5.54	0.14	0.37
LIT-13	16.59	16.59	0.00	1.00	0.002	0.021	0.71	0.71	3.00	4.00	4.21	0.18	0.28
LIT-13	22.45	22.45	0.00	1.00	0.002	0.021	0.84	0.84	3.00	4.00	3.57	0.21	0.25
LIT-13	28.49	28.49	0.00	1.00	0.002	0.021	0.98	0.98	3.00	4.00	3.07	0.24	0.22
LIT-14	5.13	5.13	0.00	1.00	0.002	0.063	0.52	0.52	1.25	2.00	2.41	0.26	0.58
LIT-14	6.69	6.69	0.00	1.00	0.002	0.063	0.65	0.65	1.25	2.00	1.93	0.32	0.44
LIT-14	8.61	8.61	0.00	1.00	0.002	0.063	0.76	0.76	1.25	2.00	1.64	0.38	0.37

Continued on next page

Table 5: Literature-Derived Performance Data for Drop-Type Inlets — Continued

ID-CODE	Q_A	Q_I	Q_O	Q_R	S_0	S_x	d_a	h_b	L_I	W_I	L_R	W_R	Fr
LIT-14	10.41	10.41	0.00	1.00	0.002	0.063	0.89	0.89	1.25	2.00	1.40	0.45	0.30
LIT-14	12.20	12.20	0.00	1.00	0.002	0.063	1.05	1.05	1.25	2.00	1.19	0.53	0.24
LIT-14	5.00	5.00	0.00	1.00	0.002	0.063	0.50	0.50	1.25	2.67	2.52	0.19	0.64
LIT-14	7.46	7.46	0.00	1.00	0.002	0.063	0.63	0.63	1.25	2.67	1.98	0.24	0.52
LIT-14	9.84	9.84	0.00	1.00	0.002	0.063	0.74	0.74	1.25	2.67	1.70	0.28	0.46
LIT-14	12.45	12.45	0.00	1.00	0.002	0.063	0.88	0.88	1.25	2.67	1.42	0.33	0.38
LIT-14	14.62	14.62	0.00	1.00	0.002	0.063	1.02	1.02	1.25	2.67	1.23	0.38	0.31
LIT-14	5.23	5.23	0.00	1.00	0.002	0.063	0.47	0.47	2.00	2.00	4.21	0.24	0.74
LIT-14	7.86	7.86	0.00	1.00	0.002	0.063	0.63	0.63	2.00	2.00	3.18	0.31	0.55
LIT-14	10.76	10.76	0.00	1.00	0.002	0.063	0.75	0.75	2.00	2.00	2.65	0.38	0.48
LIT-14	13.60	13.60	0.00	1.00	0.002	0.063	0.88	0.88	2.00	2.00	2.27	0.44	0.41
LIT-14	16.49	16.49	0.00	1.00	0.002	0.063	1.03	1.03	2.00	2.00	1.93	0.52	0.33
LIT-14	5.68	5.68	0.00	1.00	0.002	0.063	0.42	0.42	2.00	4.00	4.74	0.11	1.08
LIT-14	9.49	9.49	0.00	1.00	0.002	0.063	0.58	0.58	2.00	4.00	3.47	0.14	0.83
LIT-14	12.68	12.68	0.00	1.00	0.002	0.063	0.67	0.67	2.00	4.00	2.97	0.17	0.75
LIT-14	15.79	15.79	0.00	1.00	0.002	0.063	0.78	0.78	2.00	4.00	2.58	0.19	0.65
LIT-14	19.12	19.12	0.00	1.00	0.002	0.063	0.87	0.87	2.00	4.00	2.29	0.22	0.59
LIT-14	22.38	22.38	0.00	1.00	0.002	0.063	0.98	0.98	2.00	4.00	2.05	0.24	0.52
LIT-14	5.06	5.06	0.00	1.00	0.002	0.063	0.42	0.42	3.00	2.00	7.06	0.21	0.95
LIT-14	10.04	10.04	0.00	1.00	0.002	0.063	0.62	0.62	3.00	2.00	4.84	0.31	0.73
LIT-14	15.27	15.27	0.00	1.00	0.002	0.063	0.80	0.80	3.00	2.00	3.76	0.40	0.59
LIT-14	20.42	20.42	0.00	1.00	0.002	0.063	0.95	0.95	3.00	2.00	3.15	0.48	0.51
LIT-14	25.66	25.66	0.00	1.00	0.002	0.063	1.15	1.15	3.00	2.00	2.61	0.57	0.40
LIT-14	5.00	5.00	0.00	1.00	0.002	0.063	0.40	0.40	3.00	4.00	7.58	0.10	1.12
LIT-14	10.77	10.77	0.00	1.00	0.002	0.063	0.58	0.58	3.00	4.00	5.19	0.14	0.93
LIT-14	16.48	16.48	0.00	1.00	0.002	0.063	0.75	0.75	3.00	4.00	4.03	0.19	0.76
LIT-14	22.36	22.36	0.00	1.00	0.002	0.063	0.88	0.88	3.00	4.00	3.41	0.22	0.68
LIT-14	28.47	28.47	0.00	1.00	0.002	0.063	1.01	1.01	3.00	4.00	2.97	0.25	0.61
LIT-14	5.04	5.04	0.00	1.00	0.002	0.042	0.54	0.54	1.25	2.00	2.30	0.27	0.34
LIT-14	6.61	6.61	0.00	1.00	0.002	0.042	0.64	0.64	1.25	2.00	1.95	0.32	0.30
LIT-14	8.55	8.55	0.00	1.00	0.002	0.042	0.76	0.76	1.25	2.00	1.64	0.38	0.25
LIT-14	10.36	10.36	0.00	1.00	0.002	0.042	0.89	0.89	1.25	2.00	1.41	0.44	0.21
LIT-14	12.24	12.24	0.00	1.00	0.002	0.042	1.06	1.06	1.25	2.00	1.18	0.53	0.16
LIT-14	4.94	4.94	0.00	1.00	0.002	0.042	0.49	0.49	1.25	2.67	2.56	0.18	0.44
LIT-14	7.43	7.43	0.00	1.00	0.002	0.042	0.62	0.62	1.25	2.67	2.00	0.23	0.36
LIT-14	9.61	9.61	0.00	1.00	0.002	0.042	0.73	0.73	1.25	2.67	1.71	0.27	0.31
LIT-14	12.40	12.40	0.00	1.00	0.002	0.042	0.87	0.87	1.25	2.67	1.44	0.32	0.26
LIT-14	14.64	14.64	0.00	1.00	0.002	0.042	1.01	1.01	1.25	2.67	1.23	0.38	0.21
LIT-14	5.20	5.20	0.00	1.00	0.002	0.042	0.47	0.47	2.00	2.00	4.26	0.23	0.51

Continued on next page

Table 5: Literature-Derived Performance Data for Drop-Type Inlets — Continued

ID-CODE	Q_A	Q_I	Q_O	Q_R	S_0	S_x	d_a	h_b	L_I	W_I	L_R	W_R	Fr
LIT-14	7.90	7.90	0.00	1.00	0.002	0.042	0.62	0.62	2.00	2.00	3.24	0.31	0.39
LIT-14	10.64	10.64	0.00	1.00	0.002	0.042	0.74	0.74	2.00	2.00	2.69	0.37	0.33
LIT-14	13.48	13.48	0.00	1.00	0.002	0.042	0.85	0.85	2.00	2.00	2.34	0.43	0.30
LIT-14	16.53	16.53	0.00	1.00	0.002	0.042	1.03	1.03	2.00	2.00	1.94	0.51	0.23
LIT-14	5.34	5.34	0.00	1.00	0.002	0.042	0.38	0.38	2.00	4.00	5.24	0.10	0.88
LIT-14	10.37	10.37	0.00	1.00	0.002	0.042	0.57	0.57	2.00	4.00	3.51	0.14	0.63
LIT-14	15.40	15.40	0.00	1.00	0.002	0.042	0.74	0.74	2.00	4.00	2.72	0.18	0.49
LIT-14	20.22	20.22	0.00	1.00	0.002	0.042	0.88	0.88	2.00	4.00	2.27	0.22	0.41
LIT-14	24.80	24.80	0.00	1.00	0.002	0.042	1.01	1.01	2.00	4.00	1.97	0.25	0.35
LIT-14	5.00	5.00	0.00	1.00	0.002	0.042	0.42	0.42	3.00	2.00	7.22	0.21	0.66
LIT-14	10.13	10.13	0.00	1.00	0.002	0.042	0.61	0.61	3.00	2.00	4.96	0.30	0.53
LIT-14	15.29	15.29	0.00	1.00	0.002	0.042	0.78	0.78	3.00	2.00	3.86	0.39	0.43
LIT-14	20.43	20.43	0.00	1.00	0.002	0.042	0.95	0.95	3.00	2.00	3.17	0.47	0.35
LIT-14	25.56	25.56	0.00	1.00	0.002	0.042	1.11	1.11	3.00	2.00	2.70	0.56	0.29
LIT-14	4.88	4.88	0.00	1.00	0.002	0.042	0.35	0.35	3.00	4.00	8.64	0.09	1.02
LIT-14	10.70	10.70	0.00	1.00	0.002	0.042	0.55	0.55	3.00	4.00	5.46	0.14	0.71
LIT-14	16.70	16.70	0.00	1.00	0.002	0.042	0.72	0.72	3.00	4.00	4.15	0.18	0.56
LIT-14	22.42	22.42	0.00	1.00	0.002	0.042	0.86	0.86	3.00	4.00	3.50	0.21	0.49
LIT-14	28.49	28.49	0.00	1.00	0.002	0.042	1.01	1.01	3.00	4.00	2.97	0.25	0.41
LIT-14	5.09	5.09	0.00	1.00	0.002	0.021	0.53	0.53	1.25	2.00	2.34	0.27	0.18
LIT-14	6.70	6.70	0.00	1.00	0.002	0.021	0.64	0.64	1.25	2.00	1.95	0.32	0.15
LIT-14	8.47	8.47	0.00	1.00	0.002	0.021	0.75	0.75	1.25	2.00	1.67	0.37	0.13
LIT-14	10.43	10.43	0.00	1.00	0.002	0.021	0.89	0.89	1.25	2.00	1.40	0.45	0.10
LIT-14	12.24	12.24	0.00	1.00	0.002	0.021	1.05	1.05	1.25	2.00	1.19	0.53	0.08
LIT-14	4.99	4.99	0.00	1.00	0.002	0.021	0.48	0.48	1.25	2.67	2.63	0.18	0.23
LIT-14	7.46	7.46	0.00	1.00	0.002	0.021	0.61	0.61	1.25	2.67	2.06	0.23	0.19
LIT-14	9.65	9.65	0.00	1.00	0.002	0.021	0.72	0.72	1.25	2.67	1.74	0.27	0.16
LIT-14	12.36	12.36	0.00	1.00	0.002	0.021	0.85	0.85	1.25	2.67	1.48	0.32	0.14
LIT-14	14.68	14.68	0.00	1.00	0.002	0.021	1.00	1.00	1.25	2.67	1.24	0.38	0.11
LIT-14	5.14	5.14	0.00	1.00	0.002	0.021	0.44	0.44	2.00	2.00	4.51	0.22	0.29
LIT-14	7.86	7.86	0.00	1.00	0.002	0.021	0.60	0.60	2.00	2.00	3.36	0.30	0.21
LIT-14	10.67	10.67	0.00	1.00	0.002	0.021	0.73	0.73	2.00	2.00	2.75	0.36	0.17
LIT-14	13.58	13.58	0.00	1.00	0.002	0.021	0.84	0.84	2.00	2.00	2.38	0.42	0.15
LIT-14	16.55	16.55	0.00	1.00	0.002	0.021	1.01	1.01	2.00	2.00	1.98	0.51	0.12
LIT-14	7.39	7.39	0.00	1.00	0.002	0.021	0.45	0.45	2.00	4.00	4.45	0.11	0.40
LIT-14	11.99	11.99	0.00	1.00	0.002	0.021	0.62	0.62	2.00	4.00	3.25	0.15	0.30
LIT-14	16.85	16.85	0.00	1.00	0.002	0.021	0.76	0.76	2.00	4.00	2.63	0.19	0.25
LIT-14	21.60	21.60	0.00	1.00	0.002	0.021	0.89	0.89	2.00	4.00	2.24	0.22	0.21
LIT-14	4.90	4.90	0.00	1.00	0.002	0.021	0.38	0.38	3.00	2.00	7.86	0.19	0.40

Continued on next page

Table 5: Literature-Derived Performance Data for Drop-Type Inlets — Continued

ID-CODE	Q_A	Q_I	Q_O	Q_R	S_0	S_x	d_a	h_b	L_I	W_I	L_R	W_R	Fr
LIT-14	9.46	9.46	0.00	1.00	0.002	0.021	0.56	0.56	3.00	2.00	5.35	0.28	0.29
LIT-14	14.24	14.24	0.00	1.00	0.002	0.021	0.72	0.72	3.00	2.00	4.19	0.36	0.24
LIT-14	18.61	18.61	0.00	1.00	0.002	0.021	0.85	0.85	3.00	2.00	3.55	0.42	0.21
LIT-14	22.64	22.64	0.00	1.00	0.002	0.021	1.00	1.00	3.00	2.00	3.00	0.50	0.17
LIT-14	4.87	4.87	0.00	1.00	0.002	0.021	0.33	0.33	3.00	4.00	8.99	0.08	0.55
LIT-14	10.76	10.76	0.00	1.00	0.002	0.021	0.53	0.53	3.00	4.00	5.63	0.13	0.38
LIT-14	16.55	16.55	0.00	1.00	0.002	0.021	0.68	0.68	3.00	4.00	4.39	0.17	0.31
LIT-14	22.43	22.43	0.00	1.00	0.002	0.021	0.83	0.83	3.00	4.00	3.62	0.21	0.26
LIT-14	28.44	28.44	0.00	1.00	0.002	0.021	0.95	0.95	3.00	4.00	3.14	0.24	0.23
LIT-15	5.44	5.44	0.00	1.00	0.002	0.063	0.60	0.60	1.25	2.00	2.10	0.30	0.44
LIT-15	6.44	6.44	0.00	1.00	0.002	0.063	0.70	0.70	1.25	2.00	1.80	0.35	0.35
LIT-15	7.19	7.19	0.00	1.00	0.002	0.063	0.79	0.79	1.25	2.00	1.58	0.40	0.28
LIT-15	7.87	7.87	0.00	1.00	0.002	0.063	0.90	0.90	1.25	2.00	1.39	0.45	0.23
LIT-15	5.49	5.49	0.00	1.00	0.002	0.063	0.54	0.54	1.25	2.67	2.33	0.20	0.57
LIT-15	6.98	6.98	0.00	1.00	0.002	0.063	0.64	0.64	1.25	2.67	1.94	0.24	0.46
LIT-15	8.48	8.48	0.00	1.00	0.002	0.063	0.75	0.75	1.25	2.67	1.68	0.28	0.39
LIT-15	9.60	9.60	0.00	1.00	0.002	0.063	0.84	0.84	1.25	2.67	1.48	0.32	0.32
LIT-15	10.39	10.39	0.00	1.00	0.002	0.063	0.95	0.95	1.25	2.67	1.32	0.35	0.26
LIT-15	5.56	5.56	0.00	1.00	0.002	0.063	0.50	0.50	2.00	2.00	3.98	0.25	0.68
LIT-15	7.36	7.36	0.00	1.00	0.002	0.063	0.61	0.61	2.00	2.00	3.30	0.30	0.57
LIT-15	9.10	9.10	0.00	1.00	0.002	0.063	0.71	0.71	2.00	2.00	2.82	0.35	0.47
LIT-15	10.31	10.31	0.00	1.00	0.002	0.063	0.81	0.81	2.00	2.00	2.48	0.40	0.39
LIT-15	11.30	11.30	0.00	1.00	0.002	0.063	0.91	0.91	2.00	2.00	2.19	0.46	0.31
LIT-15	5.90	5.90	0.00	1.00	0.002	0.063	0.44	0.44	2.00	4.00	4.56	0.11	1.02
LIT-15	8.54	8.54	0.00	1.00	0.002	0.063	0.54	0.54	2.00	4.00	3.70	0.13	0.88
LIT-15	11.38	11.38	0.00	1.00	0.002	0.063	0.64	0.64	2.00	4.00	3.13	0.16	0.77
LIT-15	14.33	14.33	0.00	1.00	0.002	0.063	0.74	0.74	2.00	4.00	2.71	0.18	0.67
LIT-15	17.33	17.33	0.00	1.00	0.002	0.063	0.85	0.85	2.00	4.00	2.37	0.21	0.58
LIT-15	20.06	20.06	0.00	1.00	0.002	0.063	0.95	0.95	2.00	4.00	2.11	0.24	0.50
LIT-15	5.42	5.42	0.00	1.00	0.002	0.063	0.44	0.44	3.00	2.00	6.78	0.22	0.92
LIT-15	8.27	8.27	0.00	1.00	0.002	0.063	0.55	0.55	3.00	2.00	5.50	0.27	0.83
LIT-15	10.54	10.54	0.00	1.00	0.002	0.063	0.65	0.65	3.00	2.00	4.64	0.32	0.69
LIT-15	12.64	12.64	0.00	1.00	0.002	0.063	0.75	0.75	3.00	2.00	4.02	0.37	0.58
LIT-15	14.47	14.47	0.00	1.00	0.002	0.063	0.84	0.84	3.00	2.00	3.55	0.42	0.49
LIT-15	15.61	15.61	0.00	1.00	0.002	0.063	0.95	0.95	3.00	2.00	3.15	0.48	0.39
LIT-15	6.23	6.23	0.00	1.00	0.002	0.063	0.44	0.44	3.00	4.00	6.80	0.11	1.06
LIT-15	9.65	9.65	0.00	1.00	0.002	0.063	0.54	0.54	3.00	4.00	5.57	0.13	1.00
LIT-15	13.03	13.03	0.00	1.00	0.002	0.063	0.65	0.65	3.00	4.00	4.65	0.16	0.86
LIT-15	16.56	16.56	0.00	1.00	0.002	0.063	0.74	0.74	3.00	4.00	4.03	0.19	0.76

Continued on next page

Table 5: Literature-Derived Performance Data for Drop-Type Inlets — Continued

ID-CODE	Q_A	Q_I	Q_O	Q_R	S_0	S_x	d_a	h_b	L_I	W_I	L_R	W_R	Fr
LIT-15	20.46	20.46	0.00	1.00	0.002	0.063	0.85	0.85	3.00	4.00	3.54	0.21	0.68
LIT-15	24.46	24.46	0.00	1.00	0.002	0.063	0.95	0.95	3.00	4.00	3.14	0.24	0.60
LIT-15	5.52	5.52	0.00	1.00	0.002	0.042	0.60	0.60	1.25	2.00	2.09	0.30	0.30
LIT-15	6.35	6.35	0.00	1.00	0.002	0.042	0.70	0.70	1.25	2.00	1.78	0.35	0.23
LIT-15	7.14	7.14	0.00	1.00	0.002	0.042	0.80	0.80	1.25	2.00	1.57	0.40	0.19
LIT-15	7.69	7.69	0.00	1.00	0.002	0.042	0.90	0.90	1.25	2.00	1.38	0.45	0.15
LIT-15	5.44	5.44	0.00	1.00	0.002	0.042	0.54	0.54	1.25	2.67	2.30	0.20	0.37
LIT-15	6.95	6.95	0.00	1.00	0.002	0.042	0.65	0.65	1.25	2.67	1.93	0.24	0.31
LIT-15	8.34	8.34	0.00	1.00	0.002	0.042	0.75	0.75	1.25	2.67	1.66	0.28	0.25
LIT-15	9.59	9.59	0.00	1.00	0.002	0.042	0.85	0.85	1.25	2.67	1.47	0.32	0.21
LIT-15	10.38	10.38	0.00	1.00	0.002	0.042	0.94	0.94	1.25	2.67	1.32	0.35	0.18
LIT-15	5.64	5.64	0.00	1.00	0.002	0.042	0.50	0.50	2.00	2.00	3.98	0.25	0.47
LIT-15	7.45	7.45	0.00	1.00	0.002	0.042	0.61	0.61	2.00	2.00	3.27	0.31	0.38
LIT-15	9.21	9.21	0.00	1.00	0.002	0.042	0.71	0.71	2.00	2.00	2.80	0.36	0.32
LIT-15	10.36	10.36	0.00	1.00	0.002	0.042	0.81	0.81	2.00	2.00	2.47	0.40	0.26
LIT-15	11.34	11.34	0.00	1.00	0.002	0.042	0.92	0.92	2.00	2.00	2.18	0.46	0.21
LIT-15	6.40	6.40	0.00	1.00	0.002	0.042	0.44	0.44	2.00	4.00	4.56	0.11	0.74
LIT-15	8.90	8.90	0.00	1.00	0.002	0.042	0.55	0.55	2.00	4.00	3.65	0.14	0.59
LIT-15	11.68	11.68	0.00	1.00	0.002	0.042	0.65	0.65	2.00	4.00	3.10	0.16	0.52
LIT-15	14.64	14.64	0.00	1.00	0.002	0.042	0.75	0.75	2.00	4.00	2.65	0.19	0.44
LIT-15	17.51	17.51	0.00	1.00	0.002	0.042	0.85	0.85	2.00	4.00	2.36	0.21	0.39
LIT-15	20.50	20.50	0.00	1.00	0.002	0.042	0.95	0.95	2.00	4.00	2.11	0.24	0.35
LIT-15	5.85	5.85	0.00	1.00	0.002	0.042	0.45	0.45	3.00	2.00	6.67	0.22	0.64
LIT-15	8.38	8.38	0.00	1.00	0.002	0.042	0.55	0.55	3.00	2.00	5.44	0.28	0.55
LIT-15	10.62	10.62	0.00	1.00	0.002	0.042	0.65	0.65	3.00	2.00	4.62	0.32	0.46
LIT-15	12.67	12.67	0.00	1.00	0.002	0.042	0.75	0.75	3.00	2.00	3.99	0.38	0.38
LIT-15	14.47	14.47	0.00	1.00	0.002	0.042	0.85	0.85	3.00	2.00	3.53	0.42	0.32
LIT-15	15.69	15.69	0.00	1.00	0.002	0.042	0.95	0.95	3.00	2.00	3.16	0.47	0.26
LIT-15	7.28	7.28	0.00	1.00	0.002	0.042	0.45	0.45	3.00	4.00	6.73	0.11	0.81
LIT-15	10.45	10.45	0.00	1.00	0.002	0.042	0.55	0.55	3.00	4.00	5.50	0.14	0.70
LIT-15	13.71	13.71	0.00	1.00	0.002	0.042	0.65	0.65	3.00	4.00	4.64	0.16	0.60
LIT-15	17.28	17.28	0.00	1.00	0.002	0.042	0.75	0.75	3.00	4.00	4.01	0.19	0.53
LIT-15	21.22	21.22	0.00	1.00	0.002	0.042	0.85	0.85	3.00	4.00	3.54	0.21	0.48
LIT-15	25.21	25.21	0.00	1.00	0.002	0.042	0.95	0.95	3.00	4.00	3.15	0.24	0.42
LIT-15	5.57	5.57	0.00	1.00	0.002	0.021	0.59	0.59	1.25	2.00	2.10	0.30	0.15
LIT-15	6.53	6.53	0.00	1.00	0.002	0.021	0.70	0.70	1.25	2.00	1.79	0.35	0.12
LIT-15	7.39	7.39	0.00	1.00	0.002	0.021	0.80	0.80	1.25	2.00	1.56	0.40	0.09
LIT-15	7.82	7.82	0.00	1.00	0.002	0.021	0.90	0.90	1.25	2.00	1.39	0.45	0.07
LIT-15	5.67	5.67	0.00	1.00	0.002	0.021	0.54	0.54	1.25	2.67	2.31	0.20	0.19

Continued on next page

Table 5: Literature-Derived Performance Data for Drop-Type Inlets — Continued

ID-CODE	Q_A	Q_I	Q_O	Q_R	S_0	S_x	d_a	h_b	L_I	W_I	L_R	W_R	Fr
LIT-15	7.25	7.25	0.00	1.00	0.002	0.021	0.64	0.64	1.25	2.67	1.94	0.24	0.16
LIT-15	8.53	8.53	0.00	1.00	0.002	0.021	0.75	0.75	1.25	2.67	1.68	0.28	0.13
LIT-15	9.68	9.68	0.00	1.00	0.002	0.021	0.85	0.85	1.25	2.67	1.48	0.32	0.11
LIT-15	10.56	10.56	0.00	1.00	0.002	0.021	0.94	0.94	1.25	2.67	1.33	0.35	0.09
LIT-15	6.07	6.07	0.00	1.00	0.002	0.021	0.50	0.50	2.00	2.00	3.99	0.25	0.25
LIT-15	7.79	7.79	0.00	1.00	0.002	0.021	0.61	0.61	2.00	2.00	3.29	0.30	0.20
LIT-15	9.49	9.49	0.00	1.00	0.002	0.021	0.71	0.71	2.00	2.00	2.84	0.35	0.17
LIT-15	10.64	10.64	0.00	1.00	0.002	0.021	0.81	0.81	2.00	2.00	2.47	0.40	0.13
LIT-15	11.52	11.52	0.00	1.00	0.002	0.021	0.91	0.91	2.00	2.00	2.20	0.45	0.11
LIT-15	6.80	6.80	0.00	1.00	0.002	0.021	0.44	0.44	2.00	4.00	4.55	0.11	0.39
LIT-15	9.40	9.40	0.00	1.00	0.002	0.021	0.54	0.54	2.00	4.00	3.70	0.14	0.32
LIT-15	11.89	11.89	0.00	1.00	0.002	0.021	0.65	0.65	2.00	4.00	3.10	0.16	0.26
LIT-15	15.26	15.26	0.00	1.00	0.002	0.021	0.75	0.75	2.00	4.00	2.68	0.19	0.23
LIT-15	18.31	18.31	0.00	1.00	0.002	0.021	0.84	0.84	2.00	4.00	2.37	0.21	0.21
LIT-15	6.27	6.27	0.00	1.00	0.002	0.021	0.44	0.44	3.00	2.00	6.85	0.22	0.36
LIT-15	8.67	8.67	0.00	1.00	0.002	0.021	0.54	0.54	3.00	2.00	5.57	0.27	0.30
LIT-15	11.13	11.13	0.00	1.00	0.002	0.021	0.65	0.65	3.00	2.00	4.60	0.33	0.24
LIT-15	12.88	12.88	0.00	1.00	0.002	0.021	0.75	0.75	3.00	2.00	4.01	0.37	0.19
LIT-15	14.48	14.48	0.00	1.00	0.002	0.021	0.85	0.85	3.00	2.00	3.54	0.42	0.16
LIT-15	15.89	15.89	0.00	1.00	0.002	0.021	0.95	0.95	3.00	2.00	3.17	0.47	0.13
LIT-15	7.75	7.75	0.00	1.00	0.002	0.021	0.44	0.44	3.00	4.00	6.77	0.11	0.43
LIT-15	10.83	10.83	0.00	1.00	0.002	0.021	0.54	0.54	3.00	4.00	5.53	0.14	0.37
LIT-15	14.41	14.41	0.00	1.00	0.002	0.021	0.64	0.64	3.00	4.00	4.68	0.16	0.32
LIT-15	17.91	17.91	0.00	1.00	0.002	0.021	0.75	0.75	3.00	4.00	4.01	0.19	0.27
LIT-15	21.94	21.94	0.00	1.00	0.002	0.021	0.85	0.85	3.00	4.00	3.53	0.21	0.24
LIT-15	25.93	25.93	0.00	1.00	0.002	0.021	0.95	0.95	3.00	4.00	3.17	0.24	0.22
LIT-16	0.02	0.01	0.00	0.96	0.000	0.020	0.03	0.00	1.00	1.00	33.33	0.03	0.72
LIT-16	0.04	0.04	0.00	0.95	0.000	0.020	0.03	0.00	1.00	1.00	33.33	0.03	1.85
LIT-16	0.07	0.06	0.00	0.95	0.000	0.020	0.03	0.00	1.00	1.00	33.33	0.03	3.20
LIT-16	0.13	0.12	0.01	0.95	0.000	0.020	0.03	0.00	1.00	1.00	33.33	0.03	6.07
LIT-16	0.17	0.16	0.01	0.95	0.000	0.020	0.03	0.00	1.00	1.00	33.33	0.03	8.05
LIT-16	0.19	0.18	0.01	0.95	0.000	0.020	0.03	0.00	1.00	1.00	33.33	0.03	8.97
LIT-16	0.03	0.02	0.00	0.83	0.000	0.020	0.04	0.00	1.00	1.00	25.00	0.04	0.72
LIT-16	0.04	0.03	0.01	0.82	0.000	0.020	0.04	0.00	1.00	1.00	25.00	0.04	1.03
LIT-16	0.12	0.10	0.02	0.83	0.000	0.020	0.04	0.00	1.00	1.00	25.00	0.04	3.28
LIT-16	0.16	0.14	0.03	0.83	0.000	0.020	0.04	0.00	1.00	1.00	25.00	0.04	4.39
LIT-16	0.20	0.17	0.04	0.82	0.000	0.020	0.04	0.00	1.00	1.00	25.00	0.04	5.39
LIT-16	0.24	0.19	0.04	0.81	0.000	0.020	0.04	0.00	1.00	1.00	25.00	0.04	6.34
LIT-16	0.27	0.22	0.05	0.81	0.000	0.020	0.04	0.00	1.00	1.00	25.00	0.04	7.19

Continued on next page

Table 5: Literature-Derived Performance Data for Drop-Type Inlets — Continued

ID-CODE	Q_A	Q_I	Q_O	Q_R	S_0	S_x	d_a	h_b	L_I	W_I	L_R	W_R	Fr
LIT-16	0.31	0.25	0.06	0.81	0.000	0.020	0.04	0.00	1.00	1.00	25.00	0.04	8.22
LIT-16	0.33	0.26	0.07	0.79	0.000	0.020	0.04	0.00	1.00	1.00	25.00	0.04	8.74
LIT-16	0.04	0.03	0.01	0.72	0.000	0.020	0.05	0.00	1.00	1.00	20.00	0.05	0.69
LIT-16	0.06	0.04	0.02	0.72	0.000	0.020	0.05	0.00	1.00	1.00	20.00	0.05	1.05
LIT-16	0.12	0.08	0.03	0.71	0.000	0.020	0.05	0.00	1.00	1.00	20.00	0.05	2.05
LIT-16	0.17	0.12	0.05	0.71	0.000	0.020	0.05	0.00	1.00	1.00	20.00	0.05	3.00
LIT-16	0.23	0.16	0.07	0.70	0.000	0.020	0.05	0.00	1.00	1.00	20.00	0.05	4.10
LIT-16	0.29	0.20	0.09	0.69	0.000	0.020	0.05	0.00	1.00	1.00	20.00	0.05	5.02
LIT-16	0.35	0.24	0.11	0.69	0.000	0.020	0.05	0.00	1.00	1.00	20.00	0.05	6.23
LIT-16	0.40	0.28	0.13	0.69	0.000	0.020	0.05	0.00	1.00	1.00	20.00	0.05	7.12
LIT-16	0.43	0.30	0.14	0.68	0.000	0.020	0.05	0.00	1.00	1.00	20.00	0.05	7.61
LIT-16	0.06	0.04	0.02	0.63	0.000	0.020	0.06	0.00	1.00	1.00	16.67	0.06	0.73
LIT-16	0.08	0.05	0.03	0.63	0.000	0.020	0.06	0.00	1.00	1.00	16.67	0.06	1.08
LIT-16	0.16	0.10	0.06	0.62	0.000	0.020	0.06	0.00	1.00	1.00	16.67	0.06	2.06
LIT-16	0.24	0.15	0.09	0.62	0.000	0.020	0.06	0.00	1.00	1.00	16.67	0.06	3.11
LIT-16	0.31	0.19	0.12	0.61	0.000	0.020	0.06	0.00	1.00	1.00	16.67	0.06	3.95
LIT-16	0.41	0.25	0.16	0.60	0.000	0.020	0.06	0.00	1.00	1.00	16.67	0.06	5.19
LIT-16	0.48	0.29	0.19	0.60	0.000	0.020	0.06	0.00	1.00	1.00	16.67	0.06	6.10
LIT-16	0.55	0.32	0.24	0.57	0.000	0.020	0.06	0.00	1.00	1.00	16.67	0.06	7.05
LIT-16	0.09	0.05	0.05	0.50	0.000	0.020	0.08	0.00	1.00	1.00	12.50	0.08	0.71
LIT-16	0.15	0.07	0.07	0.50	0.000	0.020	0.08	0.00	1.00	1.00	12.50	0.08	1.16
LIT-16	0.20	0.10	0.10	0.49	0.000	0.020	0.08	0.00	1.00	1.00	12.50	0.08	1.56
LIT-16	0.26	0.13	0.13	0.50	0.000	0.020	0.08	0.00	1.00	1.00	12.50	0.08	2.01
LIT-16	0.41	0.20	0.21	0.49	0.000	0.020	0.08	0.00	1.00	1.00	12.50	0.08	3.23
LIT-16	0.57	0.27	0.30	0.48	0.000	0.020	0.08	0.00	1.00	1.00	12.50	0.08	4.49
LIT-16	0.65	0.31	0.35	0.47	0.000	0.020	0.08	0.00	1.00	1.00	12.50	0.08	5.09
LIT-16	0.78	0.32	0.46	0.41	0.000	0.020	0.08	0.00	1.00	1.00	12.50	0.08	6.06
LIT-16	0.13	0.05	0.08	0.41	0.000	0.020	0.10	0.00	1.00	1.00	10.00	0.10	0.70
LIT-16	0.21	0.08	0.12	0.40	0.000	0.020	0.10	0.00	1.00	1.00	10.00	0.10	1.12
LIT-16	0.28	0.11	0.17	0.41	0.000	0.020	0.10	0.00	1.00	1.00	10.00	0.10	1.52
LIT-16	0.37	0.15	0.22	0.41	0.000	0.020	0.10	0.00	1.00	1.00	10.00	0.10	2.03
LIT-16	0.62	0.25	0.37	0.40	0.000	0.020	0.10	0.00	1.00	1.00	10.00	0.10	3.34
LIT-16	0.79	0.31	0.48	0.39	0.000	0.020	0.10	0.00	1.00	1.00	10.00	0.10	4.26
LIT-16	0.93	0.31	0.62	0.34	0.000	0.020	0.10	0.00	1.00	1.00	10.00	0.10	5.05
LIT-16	0.23	0.07	0.16	0.30	0.000	0.020	0.14	0.00	1.00	1.00	7.14	0.14	0.73
LIT-16	0.37	0.11	0.26	0.30	0.000	0.020	0.14	0.00	1.00	1.00	7.14	0.14	1.17
LIT-16	0.65	0.19	0.46	0.29	0.000	0.020	0.14	0.00	1.00	1.00	7.14	0.14	2.04
LIT-16	0.80	0.23	0.56	0.29	0.000	0.020	0.14	0.00	1.00	1.00	7.14	0.14	2.51
LIT-16	0.98	0.29	0.70	0.29	0.000	0.020	0.14	0.00	1.00	1.00	7.14	0.14	3.09

Continued on next page

Table 5: Literature-Derived Performance Data for Drop-Type Inlets — Continued

ID-CODE	Q_A	Q_I	Q_O	Q_R	S_0	S_x	d_a	h_b	L_I	W_I	L_R	W_R	Fr
LIT-16	1.29	0.29	1.00	0.23	0.000	0.020	0.14	0.00	1.00	1.00	7.14	0.14	4.05
LIT-16	0.40	0.09	0.32	0.22	0.000	0.020	0.20	0.00	1.00	1.00	5.00	0.20	0.72
LIT-16	0.63	0.14	0.49	0.22	0.000	0.020	0.20	0.00	1.00	1.00	5.00	0.20	1.12
LIT-16	0.82	0.18	0.64	0.22	0.000	0.020	0.20	0.00	1.00	1.00	5.00	0.20	1.47
LIT-16	1.12	0.24	0.89	0.21	0.000	0.020	0.20	0.00	1.00	1.00	5.00	0.20	2.02
LIT-16	1.40	0.27	1.13	0.20	0.000	0.020	0.20	0.00	1.00	1.00	5.00	0.20	2.51
LIT-16	1.70	0.28	1.42	0.17	0.000	0.020	0.20	0.00	1.00	1.00	5.00	0.20	3.04
LIT-16	0.55	0.10	0.45	0.18	0.000	0.020	0.25	0.00	1.00	1.00	4.00	0.25	0.69
LIT-16	0.84	0.15	0.69	0.18	0.000	0.020	0.25	0.00	1.00	1.00	4.00	0.25	1.07
LIT-16	1.10	0.19	0.91	0.17	0.000	0.020	0.25	0.00	1.00	1.00	4.00	0.25	1.39
LIT-16	1.45	0.24	1.21	0.17	0.000	0.020	0.25	0.00	1.00	1.00	4.00	0.25	1.84
LIT-16	1.79	0.26	1.53	0.15	0.000	0.020	0.25	0.00	1.00	1.00	4.00	0.25	2.27
LIT-16	0.76	0.11	0.65	0.14	0.000	0.020	0.30	0.00	1.00	1.00	3.33	0.30	0.72
LIT-16	1.21	0.17	1.04	0.14	0.000	0.020	0.30	0.00	1.00	1.00	3.33	0.30	1.16
LIT-16	1.57	0.22	1.35	0.14	0.000	0.020	0.30	0.00	1.00	1.00	3.33	0.30	1.50
LIT-16	1.83	0.25	1.58	0.14	0.000	0.020	0.30	0.00	1.00	1.00	3.33	0.30	1.75
LIT-16	2.13	0.26	1.87	0.12	0.000	0.020	0.30	0.00	1.00	1.00	3.33	0.30	2.03
LIT-16	0.07	0.06	0.01	0.93	0.000	0.048	0.08	0.00	1.00	1.00	12.50	0.08	0.71
LIT-16	0.12	0.11	0.01	0.92	0.000	0.048	0.08	0.00	1.00	1.00	12.50	0.08	1.25
LIT-16	0.17	0.16	0.01	0.92	0.000	0.048	0.08	0.00	1.00	1.00	12.50	0.08	1.78
LIT-16	0.22	0.20	0.02	0.91	0.000	0.048	0.08	0.00	1.00	1.00	12.50	0.08	2.21
LIT-16	0.23	0.21	0.02	0.91	0.000	0.048	0.08	0.00	1.00	1.00	12.50	0.08	2.38
LIT-16	0.29	0.26	0.03	0.91	0.000	0.048	0.08	0.00	1.00	1.00	12.50	0.08	2.97
LIT-16	0.39	0.35	0.04	0.90	0.000	0.048	0.08	0.00	1.00	1.00	12.50	0.08	4.00
LIT-16	0.44	0.39	0.05	0.89	0.000	0.048	0.08	0.00	1.00	1.00	12.50	0.08	4.49
LIT-16	0.48	0.43	0.05	0.89	0.000	0.048	0.08	0.00	1.00	1.00	12.50	0.08	4.97
LIT-16	0.54	0.47	0.06	0.88	0.000	0.048	0.08	0.00	1.00	1.00	12.50	0.08	5.50
LIT-16	0.59	0.51	0.08	0.86	0.000	0.048	0.08	0.00	1.00	1.00	12.50	0.08	6.04
LIT-16	0.11	0.09	0.02	0.80	0.000	0.048	0.10	0.00	1.00	1.00	10.00	0.10	0.72
LIT-16	0.19	0.15	0.04	0.81	0.000	0.048	0.10	0.00	1.00	1.00	10.00	0.10	1.25
LIT-16	0.34	0.27	0.07	0.80	0.000	0.048	0.10	0.00	1.00	1.00	10.00	0.10	2.24
LIT-16	0.44	0.34	0.09	0.79	0.000	0.048	0.10	0.00	1.00	1.00	10.00	0.10	2.89
LIT-16	0.62	0.48	0.13	0.78	0.000	0.048	0.10	0.00	1.00	1.00	10.00	0.10	4.10
LIT-16	0.73	0.53	0.19	0.73	0.000	0.048	0.10	0.00	1.00	1.00	10.00	0.10	4.84
LIT-16	0.79	0.53	0.26	0.67	0.000	0.048	0.10	0.00	1.00	1.00	10.00	0.10	5.22
LIT-16	0.15	0.11	0.04	0.72	0.000	0.048	0.12	0.00	1.00	1.00	8.33	0.12	0.73
LIT-16	0.29	0.21	0.08	0.72	0.000	0.048	0.12	0.00	1.00	1.00	8.33	0.12	1.40
LIT-16	0.42	0.30	0.12	0.71	0.000	0.048	0.12	0.00	1.00	1.00	8.33	0.12	2.01
LIT-16	0.65	0.45	0.19	0.70	0.000	0.048	0.12	0.00	1.00	1.00	8.33	0.12	3.06

Continued on next page

Table 5: Literature-Derived Performance Data for Drop-Type Inlets — Continued

ID-CODE	Q_A	Q_I	Q_O	Q_R	S_0	S_x	d_a	h_b	L_I	W_I	L_R	W_R	Fr
LIT-16	0.84	0.56	0.28	0.66	0.000	0.048	0.12	0.00	1.00	1.00	8.33	0.12	4.00
LIT-16	1.05	0.55	0.50	0.52	0.000	0.048	0.12	0.00	1.00	1.00	8.33	0.12	4.99
LIT-16	0.20	0.13	0.07	0.63	0.000	0.048	0.14	0.00	1.00	1.00	7.14	0.14	0.72
LIT-16	0.28	0.18	0.10	0.63	0.000	0.048	0.14	0.00	1.00	1.00	7.14	0.14	1.01
LIT-16	0.42	0.26	0.15	0.64	0.000	0.048	0.14	0.00	1.00	1.00	7.14	0.14	1.50
LIT-16	0.56	0.35	0.21	0.63	0.000	0.048	0.14	0.00	1.00	1.00	7.14	0.14	2.02
LIT-16	0.83	0.51	0.32	0.62	0.000	0.048	0.14	0.00	1.00	1.00	7.14	0.14	2.99
LIT-16	1.11	0.56	0.55	0.51	0.000	0.048	0.14	0.00	1.00	1.00	7.14	0.14	3.99
LIT-16	0.25	0.14	0.11	0.57	0.000	0.048	0.16	0.00	1.00	1.00	6.25	0.16	0.72
LIT-16	0.41	0.23	0.18	0.57	0.000	0.048	0.16	0.00	1.00	1.00	6.25	0.16	1.18
LIT-16	0.51	0.29	0.22	0.56	0.000	0.048	0.16	0.00	1.00	1.00	6.25	0.16	1.45
LIT-16	0.70	0.40	0.30	0.57	0.000	0.048	0.16	0.00	1.00	1.00	6.25	0.16	2.00
LIT-16	0.91	0.51	0.41	0.55	0.000	0.048	0.16	0.00	1.00	1.00	6.25	0.16	2.61
LIT-16	1.05	0.57	0.48	0.54	0.000	0.048	0.16	0.00	1.00	1.00	6.25	0.16	3.01
LIT-16	1.40	0.57	0.83	0.41	0.000	0.048	0.16	0.00	1.00	1.00	6.25	0.16	4.02
LIT-16	0.31	0.16	0.15	0.51	0.000	0.048	0.18	0.00	1.00	1.00	5.56	0.18	0.72
LIT-16	0.43	0.22	0.21	0.52	0.000	0.048	0.18	0.00	1.00	1.00	5.56	0.18	1.00
LIT-16	0.63	0.32	0.30	0.52	0.000	0.048	0.18	0.00	1.00	1.00	5.56	0.18	1.48
LIT-16	0.86	0.44	0.42	0.51	0.000	0.048	0.18	0.00	1.00	1.00	5.56	0.18	2.01
LIT-16	1.08	0.54	0.54	0.50	0.000	0.048	0.18	0.00	1.00	1.00	5.56	0.18	2.53
LIT-16	1.29	0.59	0.70	0.46	0.000	0.048	0.18	0.00	1.00	1.00	5.56	0.18	3.02
LIT-16	1.69	0.55	1.15	0.32	0.000	0.048	0.18	0.00	1.00	1.00	5.56	0.18	3.97
LIT-16	0.36	0.17	0.19	0.46	0.000	0.048	0.20	0.00	1.00	1.00	5.00	0.20	0.71
LIT-16	0.54	0.25	0.29	0.47	0.000	0.048	0.20	0.00	1.00	1.00	5.00	0.20	1.07
LIT-16	0.76	0.36	0.41	0.47	0.000	0.048	0.20	0.00	1.00	1.00	5.00	0.20	1.50
LIT-16	1.01	0.47	0.54	0.46	0.000	0.048	0.20	0.00	1.00	1.00	5.00	0.20	1.98
LIT-16	1.29	0.57	0.71	0.45	0.000	0.048	0.20	0.00	1.00	1.00	5.00	0.20	2.53
LIT-16	1.54	0.59	0.96	0.38	0.000	0.048	0.20	0.00	1.00	1.00	5.00	0.20	3.03
LIT-16	1.78	0.56	1.22	0.31	0.000	0.048	0.20	0.00	1.00	1.00	5.00	0.20	3.49
LIT-16	0.51	0.20	0.31	0.38	0.000	0.048	0.25	0.00	1.00	1.00	4.00	0.25	0.69
LIT-16	0.82	0.31	0.50	0.38	0.000	0.048	0.25	0.00	1.00	1.00	4.00	0.25	1.11
LIT-16	1.14	0.44	0.70	0.39	0.000	0.048	0.25	0.00	1.00	1.00	4.00	0.25	1.56
LIT-16	1.53	0.56	0.96	0.37	0.000	0.048	0.25	0.00	1.00	1.00	4.00	0.25	2.08
LIT-16	1.91	0.57	1.34	0.30	0.000	0.048	0.25	0.00	1.00	1.00	4.00	0.25	2.59
LIT-16	0.70	0.23	0.46	0.34	0.000	0.048	0.30	0.00	1.00	1.00	3.33	0.30	0.71
LIT-16	1.12	0.37	0.75	0.33	0.000	0.048	0.30	0.00	1.00	1.00	3.33	0.30	1.14
LIT-16	1.49	0.49	1.00	0.33	0.000	0.048	0.30	0.00	1.00	1.00	3.33	0.30	1.51
LIT-16	1.77	0.55	1.21	0.31	0.000	0.048	0.30	0.00	1.00	1.00	3.33	0.30	1.79
LIT-16	2.06	0.54	1.51	0.26	0.000	0.048	0.30	0.00	1.00	1.00	3.33	0.30	2.09

Continued on next page

Table 5: Literature-Derived Performance Data for Drop-Type Inlets — Continued

ID-CODE	Q_A	Q_I	Q_O	Q_R	S_0	S_x	d_a	h_b	L_I	W_I	L_R	W_R	Fr
LIT-17	0.04	0.04	0.00	0.99	0.000	0.048	0.06	0.00	1.00	1.00	16.67	0.06	0.69
LIT-17	0.05	0.05	0.00	0.99	0.000	0.048	0.06	0.00	1.00	1.00	16.67	0.06	0.97
LIT-17	0.10	0.10	0.00	0.99	0.000	0.048	0.06	0.00	1.00	1.00	16.67	0.06	1.95
LIT-17	0.15	0.15	0.00	1.00	0.000	0.048	0.06	0.00	1.00	1.00	16.67	0.06	2.98
LIT-17	0.21	0.19	0.01	0.94	0.000	0.048	0.06	0.00	1.00	1.00	16.67	0.06	3.98
LIT-17	0.28	0.23	0.05	0.81	0.000	0.048	0.06	0.00	1.00	1.00	16.67	0.06	5.48
LIT-17	0.32	0.24	0.07	0.77	0.000	0.048	0.06	0.00	1.00	1.00	16.67	0.06	6.07
LIT-17	0.37	0.26	0.10	0.72	0.000	0.048	0.06	0.00	1.00	1.00	16.67	0.06	7.11
LIT-17	0.05	0.05	0.00	0.96	0.000	0.048	0.07	0.00	1.00	1.00	14.29	0.07	0.71
LIT-17	0.07	0.07	0.00	0.96	0.000	0.048	0.07	0.00	1.00	1.00	14.29	0.07	0.99
LIT-17	0.10	0.10	0.00	0.96	0.000	0.048	0.07	0.00	1.00	1.00	14.29	0.07	1.39
LIT-17	0.16	0.16	0.01	0.96	0.000	0.048	0.07	0.00	1.00	1.00	14.29	0.07	2.23
LIT-17	0.22	0.20	0.02	0.93	0.000	0.048	0.07	0.00	1.00	1.00	14.29	0.07	2.98
LIT-17	0.29	0.24	0.06	0.80	0.000	0.048	0.07	0.00	1.00	1.00	14.29	0.07	3.98
LIT-17	0.37	0.26	0.11	0.70	0.000	0.048	0.07	0.00	1.00	1.00	14.29	0.07	5.03
LIT-17	0.43	0.28	0.15	0.65	0.000	0.048	0.07	0.00	1.00	1.00	14.29	0.07	5.89
LIT-17	0.47	0.30	0.18	0.63	0.000	0.048	0.07	0.00	1.00	1.00	14.29	0.07	6.44
LIT-17	0.07	0.06	0.01	0.90	0.000	0.048	0.08	0.00	1.00	1.00	12.50	0.08	0.69
LIT-17	0.13	0.11	0.01	0.89	0.000	0.048	0.08	0.00	1.00	1.00	12.50	0.08	1.30
LIT-17	0.19	0.17	0.02	0.88	0.000	0.048	0.08	0.00	1.00	1.00	12.50	0.08	1.98
LIT-17	0.29	0.23	0.05	0.81	0.000	0.048	0.08	0.00	1.00	1.00	12.50	0.08	2.93
LIT-17	0.40	0.28	0.12	0.70	0.000	0.048	0.08	0.00	1.00	1.00	12.50	0.08	4.07
LIT-17	0.48	0.30	0.18	0.62	0.000	0.048	0.08	0.00	1.00	1.00	12.50	0.08	4.90
LIT-17	0.58	0.34	0.25	0.58	0.000	0.048	0.08	0.00	1.00	1.00	12.50	0.08	6.00
LIT-17	0.09	0.07	0.02	0.80	0.000	0.048	0.09	0.00	1.00	1.00	11.11	0.09	0.69
LIT-17	0.15	0.12	0.03	0.80	0.000	0.048	0.09	0.00	1.00	1.00	11.11	0.09	1.19
LIT-17	0.25	0.20	0.05	0.80	0.000	0.048	0.09	0.00	1.00	1.00	11.11	0.09	2.02
LIT-17	0.37	0.26	0.11	0.71	0.000	0.048	0.09	0.00	1.00	1.00	11.11	0.09	2.98
LIT-17	0.50	0.30	0.19	0.62	0.000	0.048	0.09	0.00	1.00	1.00	11.11	0.09	4.02
LIT-17	0.61	0.33	0.28	0.54	0.000	0.048	0.09	0.00	1.00	1.00	11.11	0.09	4.94
LIT-17	0.73	0.37	0.36	0.51	0.000	0.048	0.09	0.00	1.00	1.00	11.11	0.09	5.93
LIT-17	0.11	0.08	0.03	0.74	0.000	0.048	0.10	0.00	1.00	1.00	10.00	0.10	0.71
LIT-17	0.17	0.12	0.04	0.74	0.000	0.048	0.10	0.00	1.00	1.00	10.00	0.10	1.12
LIT-17	0.29	0.21	0.08	0.74	0.000	0.048	0.10	0.00	1.00	1.00	10.00	0.10	1.93
LIT-17	0.46	0.30	0.16	0.65	0.000	0.048	0.10	0.00	1.00	1.00	10.00	0.10	3.05
LIT-17	0.59	0.34	0.26	0.57	0.000	0.048	0.10	0.00	1.00	1.00	10.00	0.10	3.92
LIT-17	0.75	0.36	0.38	0.49	0.000	0.048	0.10	0.00	1.00	1.00	10.00	0.10	4.97
LIT-17	0.22	0.12	0.10	0.56	0.000	0.048	0.15	0.00	1.00	1.00	6.67	0.15	0.70
LIT-17	0.39	0.21	0.17	0.55	0.000	0.048	0.15	0.00	1.00	1.00	6.67	0.15	1.24

Continued on next page

Table 5: Literature-Derived Performance Data for Drop-Type Inlets — Continued

ID-CODE	Q_A	Q_I	Q_O	Q_R	S_0	S_x	d_a	h_b	L_I	W_I	L_R	W_R	Fr
LIT-17	0.46	0.25	0.21	0.55	0.000	0.048	0.15	0.00	1.00	1.00	6.67	0.15	1.46
LIT-17	0.64	0.32	0.32	0.50	0.000	0.048	0.15	0.00	1.00	1.00	6.67	0.15	2.06
LIT-17	0.89	0.39	0.50	0.44	0.000	0.048	0.15	0.00	1.00	1.00	6.67	0.15	2.86
LIT-17	1.15	0.41	0.73	0.36	0.000	0.048	0.15	0.00	1.00	1.00	6.67	0.15	3.67
LIT-17	1.40	0.44	0.96	0.32	0.000	0.048	0.15	0.00	1.00	1.00	6.67	0.15	4.47
LIT-17	0.37	0.15	0.22	0.40	0.000	0.048	0.20	0.00	1.00	1.00	5.00	0.20	0.72
LIT-17	0.53	0.21	0.32	0.40	0.000	0.048	0.20	0.00	1.00	1.00	5.00	0.20	1.03
LIT-17	1.00	0.32	0.68	0.32	0.000	0.048	0.20	0.00	1.00	1.00	5.00	0.20	1.97
LIT-17	1.52	0.34	1.18	0.22	0.000	0.048	0.20	0.00	1.00	1.00	5.00	0.20	2.99
LIT-18	0.01	0.01	0.00	0.92	0.000	0.020	0.03	0.00	1.00	1.00	33.33	0.03	0.67
LIT-18	0.05	0.04	0.00	0.90	0.000	0.020	0.03	0.00	1.00	1.00	33.33	0.03	2.16
LIT-18	0.08	0.07	0.01	0.89	0.000	0.020	0.03	0.00	1.00	1.00	33.33	0.03	3.65
LIT-18	0.11	0.10	0.01	0.87	0.000	0.020	0.03	0.00	1.00	1.00	33.33	0.03	5.36
LIT-18	0.13	0.11	0.02	0.86	0.000	0.020	0.03	0.00	1.00	1.00	33.33	0.03	6.35
LIT-18	0.18	0.15	0.03	0.84	0.000	0.020	0.03	0.00	1.00	1.00	33.33	0.03	8.67
LIT-18	0.03	0.02	0.01	0.77	0.000	0.020	0.04	0.00	1.00	1.00	25.00	0.04	0.68
LIT-18	0.09	0.07	0.02	0.76	0.000	0.020	0.04	0.00	1.00	1.00	25.00	0.04	2.42
LIT-18	0.12	0.09	0.03	0.75	0.000	0.020	0.04	0.00	1.00	1.00	25.00	0.04	3.28
LIT-18	0.15	0.12	0.04	0.75	0.000	0.020	0.04	0.00	1.00	1.00	25.00	0.04	4.12
LIT-18	0.20	0.14	0.05	0.73	0.000	0.020	0.04	0.00	1.00	1.00	25.00	0.04	5.26
LIT-18	0.24	0.17	0.07	0.73	0.000	0.020	0.04	0.00	1.00	1.00	25.00	0.04	6.32
LIT-18	0.28	0.20	0.08	0.71	0.000	0.020	0.04	0.00	1.00	1.00	25.00	0.04	7.56
LIT-18	0.31	0.21	0.10	0.68	0.000	0.020	0.04	0.00	1.00	1.00	25.00	0.04	8.29
LIT-18	0.34	0.22	0.12	0.64	0.000	0.020	0.04	0.00	1.00	1.00	25.00	0.04	8.94
LIT-18	0.04	0.03	0.01	0.67	0.000	0.020	0.05	0.00	1.00	1.00	20.00	0.05	0.66
LIT-18	0.09	0.06	0.03	0.66	0.000	0.020	0.05	0.00	1.00	1.00	20.00	0.05	1.66
LIT-18	0.13	0.09	0.05	0.65	0.000	0.020	0.05	0.00	1.00	1.00	20.00	0.05	2.35
LIT-18	0.19	0.12	0.07	0.64	0.000	0.020	0.05	0.00	1.00	1.00	20.00	0.05	3.27
LIT-18	0.22	0.14	0.08	0.63	0.000	0.020	0.05	0.00	1.00	1.00	20.00	0.05	3.96
LIT-18	0.30	0.18	0.11	0.62	0.000	0.020	0.05	0.00	1.00	1.00	20.00	0.05	5.26
LIT-18	0.34	0.21	0.13	0.61	0.000	0.020	0.05	0.00	1.00	1.00	20.00	0.05	6.05
LIT-18	0.40	0.23	0.17	0.57	0.000	0.020	0.05	0.00	1.00	1.00	20.00	0.05	7.07
LIT-18	0.43	0.22	0.21	0.51	0.000	0.020	0.05	0.00	1.00	1.00	20.00	0.05	7.57
LIT-18	0.05	0.03	0.02	0.58	0.000	0.020	0.06	0.00	1.00	1.00	16.67	0.06	0.68
LIT-18	0.13	0.08	0.06	0.57	0.000	0.020	0.06	0.00	1.00	1.00	16.67	0.06	1.67
LIT-18	0.16	0.09	0.07	0.57	0.000	0.020	0.06	0.00	1.00	1.00	16.67	0.06	2.00
LIT-18	0.24	0.13	0.10	0.56	0.000	0.020	0.06	0.00	1.00	1.00	16.67	0.06	3.03
LIT-18	0.31	0.17	0.14	0.55	0.000	0.020	0.06	0.00	1.00	1.00	16.67	0.06	4.01
LIT-18	0.40	0.22	0.18	0.54	0.000	0.020	0.06	0.00	1.00	1.00	16.67	0.06	5.07

Continued on next page

Table 5: Literature-Derived Performance Data for Drop-Type Inlets — Continued

ID-CODE	Q_A	Q_I	Q_O	Q_R	S_0	S_x	d_a	h_b	L_I	W_I	L_R	W_R	Fr
LIT-18	0.51	0.23	0.29	0.44	0.000	0.020	0.06	0.00	1.00	1.00	16.67	0.06	6.53
LIT-18	0.07	0.04	0.04	0.51	0.000	0.020	0.07	0.00	1.00	1.00	14.29	0.07	0.70
LIT-18	0.15	0.08	0.08	0.50	0.000	0.020	0.07	0.00	1.00	1.00	14.29	0.07	1.49
LIT-18	0.22	0.11	0.11	0.49	0.000	0.020	0.07	0.00	1.00	1.00	14.29	0.07	2.11
LIT-18	0.31	0.15	0.16	0.49	0.000	0.020	0.07	0.00	1.00	1.00	14.29	0.07	3.04
LIT-18	0.40	0.19	0.21	0.48	0.000	0.020	0.07	0.00	1.00	1.00	14.29	0.07	3.92
LIT-18	0.51	0.23	0.28	0.46	0.000	0.020	0.07	0.00	1.00	1.00	14.29	0.07	4.99
LIT-18	0.62	0.22	0.40	0.35	0.000	0.020	0.07	0.00	1.00	1.00	14.29	0.07	6.09
LIT-18	0.09	0.04	0.05	0.46	0.000	0.020	0.08	0.00	1.00	1.00	12.50	0.08	0.67
LIT-18	0.19	0.09	0.11	0.45	0.000	0.020	0.08	0.00	1.00	1.00	12.50	0.08	1.52
LIT-18	0.25	0.11	0.14	0.44	0.000	0.020	0.08	0.00	1.00	1.00	12.50	0.08	1.99
LIT-18	0.39	0.17	0.22	0.44	0.000	0.020	0.08	0.00	1.00	1.00	12.50	0.08	3.02
LIT-18	0.51	0.22	0.29	0.43	0.000	0.020	0.08	0.00	1.00	1.00	12.50	0.08	4.02
LIT-18	0.64	0.24	0.40	0.37	0.000	0.020	0.08	0.00	1.00	1.00	12.50	0.08	5.01
LIT-18	0.69	0.23	0.47	0.33	0.000	0.020	0.08	0.00	1.00	1.00	12.50	0.08	5.42
LIT-18	0.11	0.04	0.06	0.41	0.000	0.020	0.09	0.00	1.00	1.00	11.11	0.09	0.69
LIT-18	0.22	0.09	0.13	0.40	0.000	0.020	0.09	0.00	1.00	1.00	11.11	0.09	1.45
LIT-18	0.31	0.13	0.19	0.40	0.000	0.020	0.09	0.00	1.00	1.00	11.11	0.09	2.02
LIT-18	0.47	0.19	0.28	0.40	0.000	0.020	0.09	0.00	1.00	1.00	11.11	0.09	3.04
LIT-18	0.63	0.24	0.39	0.38	0.000	0.020	0.09	0.00	1.00	1.00	11.11	0.09	4.02
LIT-18	0.80	0.23	0.57	0.29	0.000	0.020	0.09	0.00	1.00	1.00	11.11	0.09	5.13
LIT-18	0.13	0.05	0.08	0.37	0.000	0.020	0.10	0.00	1.00	1.00	10.00	0.10	0.71
LIT-18	0.27	0.10	0.17	0.37	0.000	0.020	0.10	0.00	1.00	1.00	10.00	0.10	1.48
LIT-18	0.38	0.14	0.24	0.37	0.000	0.020	0.10	0.00	1.00	1.00	10.00	0.10	2.04
LIT-18	0.54	0.20	0.35	0.36	0.000	0.020	0.10	0.00	1.00	1.00	10.00	0.10	2.94
LIT-18	0.74	0.24	0.50	0.33	0.000	0.020	0.10	0.00	1.00	1.00	10.00	0.10	4.01
LIT-18	0.89	0.24	0.65	0.27	0.000	0.020	0.10	0.00	1.00	1.00	10.00	0.10	4.82
LIT-18	0.15	0.05	0.10	0.34	0.000	0.020	0.11	0.00	1.00	1.00	9.09	0.11	0.69
LIT-18	0.33	0.11	0.22	0.34	0.000	0.020	0.11	0.00	1.00	1.00	9.09	0.11	1.55
LIT-18	0.42	0.14	0.28	0.34	0.000	0.020	0.11	0.00	1.00	1.00	9.09	0.11	1.94
LIT-18	0.65	0.21	0.44	0.33	0.000	0.020	0.11	0.00	1.00	1.00	9.09	0.11	3.00
LIT-18	0.86	0.24	0.62	0.28	0.000	0.020	0.11	0.00	1.00	1.00	9.09	0.11	3.98
LIT-18	0.98	0.23	0.75	0.23	0.000	0.020	0.11	0.00	1.00	1.00	9.09	0.11	4.54
LIT-18	0.18	0.06	0.12	0.32	0.000	0.020	0.12	0.00	1.00	1.00	8.33	0.12	0.71
LIT-18	0.38	0.12	0.26	0.31	0.000	0.020	0.12	0.00	1.00	1.00	8.33	0.12	1.52
LIT-18	0.75	0.22	0.53	0.30	0.000	0.020	0.12	0.00	1.00	1.00	8.33	0.12	3.03
LIT-18	0.98	0.23	0.75	0.24	0.000	0.020	0.12	0.00	1.00	1.00	8.33	0.12	3.95
LIT-18	0.20	0.06	0.14	0.29	0.000	0.020	0.13	0.00	1.00	1.00	7.69	0.13	0.71
LIT-18	0.41	0.12	0.30	0.29	0.000	0.020	0.13	0.00	1.00	1.00	7.69	0.13	1.47

Continued on next page

Table 5: Literature-Derived Performance Data for Drop-Type Inlets — Continued

ID-CODE	Q_A	Q_I	Q_O	Q_R	S_0	S_x	d_a	h_b	L_I	W_I	L_R	W_R	Fr
LIT-18	0.57	0.16	0.41	0.29	0.000	0.020	0.13	0.00	1.00	1.00	7.69	0.13	2.01
LIT-18	1.11	0.21	0.90	0.19	0.000	0.020	0.13	0.00	1.00	1.00	7.69	0.13	3.92
LIT-18	0.22	0.06	0.16	0.27	0.000	0.020	0.14	0.00	1.00	1.00	7.14	0.14	0.68
LIT-18	0.45	0.12	0.33	0.27	0.000	0.020	0.14	0.00	1.00	1.00	7.14	0.14	1.41
LIT-18	0.65	0.17	0.48	0.26	0.000	0.020	0.14	0.00	1.00	1.00	7.14	0.14	2.04
LIT-18	0.80	0.21	0.59	0.26	0.000	0.020	0.14	0.00	1.00	1.00	7.14	0.14	2.52
LIT-18	0.96	0.23	0.74	0.24	0.000	0.020	0.14	0.00	1.00	1.00	7.14	0.14	3.03
LIT-18	1.13	0.22	0.91	0.20	0.000	0.020	0.14	0.00	1.00	1.00	7.14	0.14	3.55
LIT-18	0.27	0.06	0.20	0.24	0.000	0.020	0.16	0.00	1.00	1.00	6.25	0.16	0.68
LIT-18	0.56	0.13	0.43	0.24	0.000	0.020	0.16	0.00	1.00	1.00	6.25	0.16	1.44
LIT-18	0.80	0.19	0.61	0.23	0.000	0.020	0.16	0.00	1.00	1.00	6.25	0.16	2.03
LIT-18	1.19	0.22	0.98	0.18	0.000	0.020	0.16	0.00	1.00	1.00	6.25	0.16	3.04
LIT-18	1.37	0.19	1.18	0.14	0.000	0.020	0.16	0.00	1.00	1.00	6.25	0.16	3.48
LIT-18	0.32	0.07	0.26	0.21	0.000	0.020	0.18	0.00	1.00	1.00	5.56	0.18	0.69
LIT-18	0.72	0.14	0.57	0.20	0.000	0.020	0.18	0.00	1.00	1.00	5.56	0.18	1.51
LIT-18	0.94	0.19	0.75	0.20	0.000	0.020	0.18	0.00	1.00	1.00	5.56	0.18	1.99
LIT-18	1.19	0.21	0.98	0.18	0.000	0.020	0.18	0.00	1.00	1.00	5.56	0.18	2.52
LIT-18	1.43	0.20	1.23	0.14	0.000	0.020	0.18	0.00	1.00	1.00	5.56	0.18	3.02
LIT-18	0.37	0.07	0.31	0.18	0.000	0.020	0.20	0.00	1.00	1.00	5.00	0.20	0.67
LIT-18	0.80	0.15	0.66	0.18	0.000	0.020	0.20	0.00	1.00	1.00	5.00	0.20	1.44
LIT-18	1.11	0.19	0.91	0.18	0.000	0.020	0.20	0.00	1.00	1.00	5.00	0.20	1.99
LIT-18	1.38	0.20	1.18	0.15	0.000	0.020	0.20	0.00	1.00	1.00	5.00	0.20	2.48
LIT-18	1.67	0.18	1.49	0.11	0.000	0.020	0.20	0.00	1.00	1.00	5.00	0.20	3.00
LIT-18	0.55	0.08	0.47	0.14	0.000	0.020	0.25	0.00	1.00	1.00	4.00	0.25	0.70
LIT-18	1.08	0.16	0.92	0.15	0.000	0.020	0.25	0.00	1.00	1.00	4.00	0.25	1.37
LIT-18	1.45	0.18	1.27	0.13	0.000	0.020	0.25	0.00	1.00	1.00	4.00	0.25	1.84
LIT-18	1.84	0.18	1.66	0.10	0.000	0.020	0.25	0.00	1.00	1.00	4.00	0.25	2.33
LIT-18	0.04	0.04	0.00	0.95	0.000	0.048	0.06	0.00	1.00	1.00	16.67	0.06	0.71
LIT-18	0.09	0.08	0.00	0.95	0.000	0.048	0.06	0.00	1.00	1.00	16.67	0.06	1.69
LIT-18	0.15	0.14	0.01	0.95	0.000	0.048	0.06	0.00	1.00	1.00	16.67	0.06	2.83
LIT-18	0.21	0.20	0.01	0.94	0.000	0.048	0.06	0.00	1.00	1.00	16.67	0.06	4.14
LIT-18	0.25	0.24	0.02	0.92	0.000	0.048	0.06	0.00	1.00	1.00	16.67	0.06	4.91
LIT-18	0.31	0.28	0.03	0.90	0.000	0.048	0.06	0.00	1.00	1.00	16.67	0.06	5.98
LIT-18	0.36	0.29	0.07	0.81	0.000	0.048	0.06	0.00	1.00	1.00	16.67	0.06	6.87
LIT-18	0.40	0.29	0.11	0.73	0.000	0.048	0.06	0.00	1.00	1.00	16.67	0.06	7.76
LIT-18	0.05	0.05	0.00	0.93	0.000	0.048	0.07	0.00	1.00	1.00	14.29	0.07	0.71
LIT-18	0.12	0.11	0.01	0.93	0.000	0.048	0.07	0.00	1.00	1.00	14.29	0.07	1.59
LIT-18	0.16	0.15	0.01	0.92	0.000	0.048	0.07	0.00	1.00	1.00	14.29	0.07	2.14
LIT-18	0.23	0.20	0.02	0.91	0.000	0.048	0.07	0.00	1.00	1.00	14.29	0.07	3.07

Continued on next page

Table 5: Literature-Derived Performance Data for Drop-Type Inlets — Continued

ID-CODE	Q_A	Q_I	Q_O	Q_R	S_0	S_x	d_a	h_b	L_I	W_I	L_R	W_R	Fr
LIT-18	0.29	0.26	0.03	0.89	0.000	0.048	0.07	0.00	1.00	1.00	14.29	0.07	3.99
LIT-18	0.36	0.31	0.05	0.87	0.000	0.048	0.07	0.00	1.00	1.00	14.29	0.07	4.91
LIT-18	0.43	0.34	0.09	0.78	0.000	0.048	0.07	0.00	1.00	1.00	14.29	0.07	5.84
LIT-18	0.48	0.34	0.15	0.70	0.000	0.048	0.07	0.00	1.00	1.00	14.29	0.07	6.59
LIT-18	0.07	0.06	0.01	0.88	0.000	0.048	0.08	0.00	1.00	1.00	12.50	0.08	0.71
LIT-18	0.15	0.13	0.02	0.87	0.000	0.048	0.08	0.00	1.00	1.00	12.50	0.08	1.50
LIT-18	0.20	0.18	0.03	0.87	0.000	0.048	0.08	0.00	1.00	1.00	12.50	0.08	2.09
LIT-18	0.29	0.25	0.04	0.85	0.000	0.048	0.08	0.00	1.00	1.00	12.50	0.08	2.98
LIT-18	0.38	0.32	0.07	0.83	0.000	0.048	0.08	0.00	1.00	1.00	12.50	0.08	3.93
LIT-18	0.49	0.37	0.12	0.75	0.000	0.048	0.08	0.00	1.00	1.00	12.50	0.08	5.04
LIT-18	0.60	0.36	0.24	0.60	0.000	0.048	0.08	0.00	1.00	1.00	12.50	0.08	6.14
LIT-18	0.09	0.07	0.02	0.81	0.000	0.048	0.09	0.00	1.00	1.00	11.11	0.09	0.69
LIT-18	0.20	0.16	0.04	0.81	0.000	0.048	0.09	0.00	1.00	1.00	11.11	0.09	1.61
LIT-18	0.25	0.20	0.05	0.80	0.000	0.048	0.09	0.00	1.00	1.00	11.11	0.09	2.00
LIT-18	0.38	0.30	0.08	0.79	0.000	0.048	0.09	0.00	1.00	1.00	11.11	0.09	3.10
LIT-18	0.47	0.36	0.11	0.76	0.000	0.048	0.09	0.00	1.00	1.00	11.11	0.09	3.84
LIT-18	0.59	0.40	0.19	0.67	0.000	0.048	0.09	0.00	1.00	1.00	11.11	0.09	4.80
LIT-18	0.72	0.36	0.36	0.51	0.000	0.048	0.09	0.00	1.00	1.00	11.11	0.09	5.84
LIT-18	0.10	0.08	0.03	0.75	0.000	0.048	0.10	0.00	1.00	1.00	10.00	0.10	0.69
LIT-18	0.23	0.17	0.06	0.75	0.000	0.048	0.10	0.00	1.00	1.00	10.00	0.10	1.50
LIT-18	0.31	0.23	0.08	0.75	0.000	0.048	0.10	0.00	1.00	1.00	10.00	0.10	2.03
LIT-18	0.44	0.33	0.12	0.73	0.000	0.048	0.10	0.00	1.00	1.00	10.00	0.10	2.95
LIT-18	0.60	0.40	0.20	0.67	0.000	0.048	0.10	0.00	1.00	1.00	10.00	0.10	4.00
LIT-18	0.76	0.38	0.38	0.50	0.000	0.048	0.10	0.00	1.00	1.00	10.00	0.10	5.05
LIT-18	0.15	0.10	0.05	0.66	0.000	0.048	0.12	0.00	1.00	1.00	8.33	0.12	0.69
LIT-18	0.32	0.21	0.11	0.66	0.000	0.048	0.12	0.00	1.00	1.00	8.33	0.12	1.49
LIT-18	0.43	0.28	0.15	0.65	0.000	0.048	0.12	0.00	1.00	1.00	8.33	0.12	2.06
LIT-18	0.65	0.41	0.24	0.63	0.000	0.048	0.12	0.00	1.00	1.00	8.33	0.12	3.10
LIT-18	0.84	0.42	0.42	0.50	0.000	0.048	0.12	0.00	1.00	1.00	8.33	0.12	3.99
LIT-18	0.20	0.12	0.08	0.59	0.000	0.048	0.14	0.00	1.00	1.00	7.14	0.14	0.72
LIT-18	0.42	0.25	0.17	0.59	0.000	0.048	0.14	0.00	1.00	1.00	7.14	0.14	1.52
LIT-18	0.55	0.32	0.23	0.58	0.000	0.048	0.14	0.00	1.00	1.00	7.14	0.14	2.00
LIT-18	0.69	0.39	0.30	0.57	0.000	0.048	0.14	0.00	1.00	1.00	7.14	0.14	2.49
LIT-18	0.85	0.45	0.40	0.53	0.000	0.048	0.14	0.00	1.00	1.00	7.14	0.14	3.05
LIT-18	1.12	0.41	0.70	0.37	0.000	0.048	0.14	0.00	1.00	1.00	7.14	0.14	4.03
LIT-18	0.26	0.14	0.13	0.52	0.000	0.048	0.16	0.00	1.00	1.00	6.25	0.16	0.75
LIT-18	0.53	0.27	0.25	0.52	0.000	0.048	0.16	0.00	1.00	1.00	6.25	0.16	1.51
LIT-18	0.69	0.36	0.34	0.51	0.000	0.048	0.16	0.00	1.00	1.00	6.25	0.16	1.98
LIT-18	0.87	0.43	0.44	0.49	0.000	0.048	0.16	0.00	1.00	1.00	6.25	0.16	2.49

Continued on next page

Table 5: Literature-Derived Performance Data for Drop-Type Inlets — Continued

ID-CODE	Q_A	Q_I	Q_O	Q_R	S_0	S_x	d_a	h_b	L_I	W_I	L_R	W_R	Fr
LIT-18	1.05	0.44	0.61	0.42	0.000	0.048	0.16	0.00	1.00	1.00	6.25	0.16	3.00
LIT-18	0.29	0.14	0.16	0.47	0.000	0.048	0.18	0.00	1.00	1.00	5.56	0.18	0.69
LIT-18	0.65	0.30	0.35	0.46	0.000	0.048	0.18	0.00	1.00	1.00	5.56	0.18	1.52
LIT-18	0.85	0.38	0.46	0.45	0.000	0.048	0.18	0.00	1.00	1.00	5.56	0.18	1.98
LIT-18	1.07	0.43	0.63	0.41	0.000	0.048	0.18	0.00	1.00	1.00	5.56	0.18	2.50
LIT-18	1.28	0.42	0.85	0.33	0.000	0.048	0.18	0.00	1.00	1.00	5.56	0.18	2.99
LIT-18	0.36	0.15	0.21	0.43	0.000	0.048	0.20	0.00	1.00	1.00	5.00	0.20	0.70
LIT-18	0.77	0.32	0.44	0.42	0.000	0.048	0.20	0.00	1.00	1.00	5.00	0.20	1.51
LIT-18	1.02	0.41	0.61	0.40	0.000	0.048	0.20	0.00	1.00	1.00	5.00	0.20	2.01
LIT-18	1.28	0.42	0.86	0.33	0.000	0.048	0.20	0.00	1.00	1.00	5.00	0.20	2.51
LIT-18	1.53	0.40	1.13	0.26	0.000	0.048	0.20	0.00	1.00	1.00	5.00	0.20	3.00
LIT-18	0.53	0.19	0.34	0.36	0.000	0.048	0.25	0.00	1.00	1.00	4.00	0.25	0.72
LIT-18	1.15	0.37	0.78	0.32	0.000	0.048	0.25	0.00	1.00	1.00	4.00	0.25	1.56
LIT-18	1.53	0.40	1.13	0.26	0.000	0.048	0.25	0.00	1.00	1.00	4.00	0.25	2.08
LIT-18	1.89	0.34	1.55	0.18	0.000	0.048	0.25	0.00	1.00	1.00	4.00	0.25	2.57
LIT-19	0.02	0.01	0.00	0.94	0.000	0.020	0.03	0.00	1.00	1.00	33.33	0.03	0.73
LIT-19	0.04	0.04	0.00	0.93	0.000	0.020	0.03	0.00	1.00	1.00	33.33	0.03	1.86
LIT-19	0.05	0.05	0.00	0.93	0.000	0.020	0.03	0.00	1.00	1.00	33.33	0.03	2.59
LIT-19	0.07	0.07	0.01	0.92	0.000	0.020	0.03	0.00	1.00	1.00	33.33	0.03	3.39
LIT-19	0.10	0.09	0.01	0.91	0.000	0.020	0.03	0.00	1.00	1.00	33.33	0.03	4.66
LIT-19	0.13	0.12	0.01	0.91	0.000	0.020	0.03	0.00	1.00	1.00	33.33	0.03	6.41
LIT-19	0.16	0.14	0.02	0.88	0.000	0.020	0.03	0.00	1.00	1.00	33.33	0.03	7.84
LIT-19	0.19	0.17	0.02	0.88	0.000	0.020	0.03	0.00	1.00	1.00	33.33	0.03	9.04
LIT-19	0.03	0.02	0.01	0.80	0.000	0.020	0.04	0.00	1.00	1.00	25.00	0.04	0.72
LIT-19	0.06	0.05	0.01	0.80	0.000	0.020	0.04	0.00	1.00	1.00	25.00	0.04	1.55
LIT-19	0.12	0.09	0.03	0.78	0.000	0.020	0.04	0.00	1.00	1.00	25.00	0.04	3.18
LIT-19	0.21	0.16	0.05	0.76	0.000	0.020	0.04	0.00	1.00	1.00	25.00	0.04	5.52
LIT-19	0.25	0.19	0.06	0.76	0.000	0.020	0.04	0.00	1.00	1.00	25.00	0.04	6.67
LIT-19	0.30	0.22	0.08	0.74	0.000	0.020	0.04	0.00	1.00	1.00	25.00	0.04	7.93
LIT-19	0.33	0.22	0.10	0.69	0.000	0.020	0.04	0.00	1.00	1.00	25.00	0.04	8.66
LIT-19	0.04	0.03	0.01	0.70	0.000	0.020	0.05	0.00	1.00	1.00	20.00	0.05	0.74
LIT-19	0.12	0.08	0.04	0.69	0.000	0.020	0.05	0.00	1.00	1.00	20.00	0.05	2.17
LIT-19	0.18	0.12	0.06	0.69	0.000	0.020	0.05	0.00	1.00	1.00	20.00	0.05	3.20
LIT-19	0.25	0.17	0.08	0.68	0.000	0.020	0.05	0.00	1.00	1.00	20.00	0.05	4.46
LIT-19	0.30	0.20	0.10	0.67	0.000	0.020	0.05	0.00	1.00	1.00	20.00	0.05	5.32
LIT-19	0.41	0.26	0.14	0.65	0.000	0.020	0.05	0.00	1.00	1.00	20.00	0.05	7.15
LIT-19	0.44	0.26	0.18	0.59	0.000	0.020	0.05	0.00	1.00	1.00	20.00	0.05	7.83
LIT-19	0.06	0.03	0.02	0.61	0.000	0.020	0.06	0.00	1.00	1.00	16.67	0.06	0.73
LIT-19	0.17	0.10	0.07	0.60	0.000	0.020	0.06	0.00	1.00	1.00	16.67	0.06	2.23

Continued on next page

Table 5: Literature-Derived Performance Data for Drop-Type Inlets — Continued

ID-CODE	Q_A	Q_I	Q_O	Q_R	S_0	S_x	d_a	h_b	L_I	W_I	L_R	W_R	Fr
LIT-19	0.30	0.18	0.12	0.59	0.000	0.020	0.06	0.00	1.00	1.00	16.67	0.06	3.89
LIT-19	0.50	0.28	0.22	0.55	0.000	0.020	0.06	0.00	1.00	1.00	16.67	0.06	6.41
LIT-19	0.56	0.27	0.29	0.48	0.000	0.020	0.06	0.00	1.00	1.00	16.67	0.06	7.14
LIT-19	0.07	0.04	0.04	0.52	0.000	0.020	0.07	0.00	1.00	1.00	14.29	0.07	0.72
LIT-19	0.20	0.10	0.10	0.51	0.000	0.020	0.07	0.00	1.00	1.00	14.29	0.07	1.92
LIT-19	0.32	0.16	0.16	0.51	0.000	0.020	0.07	0.00	1.00	1.00	14.29	0.07	3.11
LIT-19	0.47	0.23	0.23	0.50	0.000	0.020	0.07	0.00	1.00	1.00	14.29	0.07	4.55
LIT-19	0.58	0.28	0.30	0.48	0.000	0.020	0.07	0.00	1.00	1.00	14.29	0.07	5.71
LIT-19	0.66	0.26	0.41	0.39	0.000	0.020	0.07	0.00	1.00	1.00	14.29	0.07	6.47
LIT-19	0.09	0.04	0.05	0.48	0.000	0.020	0.08	0.00	1.00	1.00	12.50	0.08	0.72
LIT-19	0.19	0.09	0.10	0.46	0.000	0.020	0.08	0.00	1.00	1.00	12.50	0.08	1.49
LIT-19	0.30	0.14	0.16	0.46	0.000	0.020	0.08	0.00	1.00	1.00	12.50	0.08	2.35
LIT-19	0.58	0.25	0.32	0.44	0.000	0.020	0.08	0.00	1.00	1.00	12.50	0.08	4.50
LIT-19	0.68	0.29	0.39	0.43	0.000	0.020	0.08	0.00	1.00	1.00	12.50	0.08	5.34
LIT-19	0.76	0.27	0.50	0.35	0.000	0.020	0.08	0.00	1.00	1.00	12.50	0.08	5.98
LIT-19	0.11	0.05	0.06	0.45	0.000	0.020	0.09	0.00	1.00	1.00	11.11	0.09	0.71
LIT-19	0.18	0.08	0.10	0.44	0.000	0.020	0.09	0.00	1.00	1.00	11.11	0.09	1.14
LIT-19	0.31	0.14	0.18	0.43	0.000	0.020	0.09	0.00	1.00	1.00	11.11	0.09	2.00
LIT-19	0.49	0.21	0.28	0.42	0.000	0.020	0.09	0.00	1.00	1.00	11.11	0.09	3.14
LIT-19	0.65	0.26	0.39	0.40	0.000	0.020	0.09	0.00	1.00	1.00	11.11	0.09	4.20
LIT-19	0.77	0.30	0.47	0.39	0.000	0.020	0.09	0.00	1.00	1.00	11.11	0.09	4.97
LIT-19	0.88	0.27	0.61	0.31	0.000	0.020	0.09	0.00	1.00	1.00	11.11	0.09	5.67
LIT-19	0.13	0.06	0.08	0.42	0.000	0.020	0.10	0.00	1.00	1.00	10.00	0.10	0.73
LIT-19	0.20	0.08	0.12	0.41	0.000	0.020	0.10	0.00	1.00	1.00	10.00	0.10	1.09
LIT-19	0.37	0.15	0.22	0.40	0.000	0.020	0.10	0.00	1.00	1.00	10.00	0.10	1.99
LIT-19	0.70	0.26	0.43	0.38	0.000	0.020	0.10	0.00	1.00	1.00	10.00	0.10	3.76
LIT-19	0.87	0.31	0.56	0.36	0.000	0.020	0.10	0.00	1.00	1.00	10.00	0.10	4.72
LIT-19	1.00	0.29	0.71	0.29	0.000	0.020	0.10	0.00	1.00	1.00	10.00	0.10	5.41
LIT-19	0.16	0.06	0.10	0.38	0.000	0.020	0.11	0.00	1.00	1.00	9.09	0.11	0.72
LIT-19	0.43	0.15	0.28	0.36	0.000	0.020	0.11	0.00	1.00	1.00	9.09	0.11	2.01
LIT-19	0.63	0.22	0.41	0.35	0.000	0.020	0.11	0.00	1.00	1.00	9.09	0.11	2.91
LIT-19	0.83	0.28	0.54	0.34	0.000	0.020	0.11	0.00	1.00	1.00	9.09	0.11	3.84
LIT-19	0.98	0.32	0.66	0.32	0.000	0.020	0.11	0.00	1.00	1.00	9.09	0.11	4.53
LIT-19	1.09	0.29	0.80	0.27	0.000	0.020	0.11	0.00	1.00	1.00	9.09	0.11	5.06
LIT-19	0.18	0.06	0.12	0.33	0.000	0.020	0.12	0.00	1.00	1.00	8.33	0.12	0.71
LIT-19	0.30	0.10	0.20	0.33	0.000	0.020	0.12	0.00	1.00	1.00	8.33	0.12	1.20
LIT-19	0.50	0.16	0.34	0.32	0.000	0.020	0.12	0.00	1.00	1.00	8.33	0.12	2.01
LIT-19	0.73	0.22	0.51	0.31	0.000	0.020	0.12	0.00	1.00	1.00	8.33	0.12	2.94
LIT-19	0.91	0.28	0.63	0.30	0.000	0.020	0.12	0.00	1.00	1.00	8.33	0.12	3.65

Continued on next page

Table 5: Literature-Derived Performance Data for Drop-Type Inlets — Continued

ID-CODE	Q_A	Q_I	Q_O	Q_R	S_0	S_x	d_a	h_b	L_I	W_I	L_R	W_R	Fr
LIT-19	1.03	0.31	0.72	0.30	0.000	0.020	0.12	0.00	1.00	1.00	8.33	0.12	4.14
LIT-19	1.16	0.28	0.89	0.24	0.000	0.020	0.12	0.00	1.00	1.00	8.33	0.12	4.69
LIT-19	0.23	0.07	0.16	0.29	0.000	0.020	0.14	0.00	1.00	1.00	7.14	0.14	0.72
LIT-19	0.45	0.13	0.32	0.29	0.000	0.020	0.14	0.00	1.00	1.00	7.14	0.14	1.40
LIT-19	0.63	0.18	0.45	0.28	0.000	0.020	0.14	0.00	1.00	1.00	7.14	0.14	1.99
LIT-19	0.87	0.24	0.63	0.28	0.000	0.020	0.14	0.00	1.00	1.00	7.14	0.14	2.74
LIT-19	1.24	0.32	0.92	0.26	0.000	0.020	0.14	0.00	1.00	1.00	7.14	0.14	3.91
LIT-19	1.40	0.30	1.09	0.22	0.000	0.020	0.14	0.00	1.00	1.00	7.14	0.14	4.39
LIT-19	0.28	0.08	0.21	0.27	0.000	0.020	0.16	0.00	1.00	1.00	6.25	0.16	0.72
LIT-19	0.75	0.19	0.56	0.25	0.000	0.020	0.16	0.00	1.00	1.00	6.25	0.16	1.90
LIT-19	1.16	0.27	0.88	0.24	0.000	0.020	0.16	0.00	1.00	1.00	6.25	0.16	2.94
LIT-19	1.41	0.32	1.10	0.22	0.000	0.020	0.16	0.00	1.00	1.00	6.25	0.16	3.60
LIT-19	1.60	0.29	1.32	0.18	0.000	0.020	0.16	0.00	1.00	1.00	6.25	0.16	4.08
LIT-19	0.35	0.09	0.27	0.24	0.000	0.020	0.18	0.00	1.00	1.00	5.56	0.18	0.75
LIT-19	0.52	0.12	0.40	0.24	0.000	0.020	0.18	0.00	1.00	1.00	5.56	0.18	1.10
LIT-19	1.25	0.27	0.97	0.22	0.000	0.020	0.18	0.00	1.00	1.00	5.56	0.18	2.64
LIT-19	1.60	0.33	1.27	0.21	0.000	0.020	0.18	0.00	1.00	1.00	5.56	0.18	3.38
LIT-19	1.82	0.29	1.53	0.16	0.000	0.020	0.18	0.00	1.00	1.00	5.56	0.18	3.85
LIT-19	0.42	0.09	0.33	0.22	0.000	0.020	0.20	0.00	1.00	1.00	5.00	0.20	0.76
LIT-19	1.16	0.24	0.92	0.20	0.000	0.020	0.20	0.00	1.00	1.00	5.00	0.20	2.08
LIT-19	1.79	0.34	1.46	0.19	0.000	0.020	0.20	0.00	1.00	1.00	5.00	0.20	3.22
LIT-19	2.02	0.30	1.72	0.15	0.000	0.020	0.20	0.00	1.00	1.00	5.00	0.20	3.62
LIT-19	0.58	0.10	0.48	0.18	0.000	0.020	0.25	0.00	1.00	1.00	4.00	0.25	0.74
LIT-19	1.12	0.19	0.93	0.17	0.000	0.020	0.25	0.00	1.00	1.00	4.00	0.25	1.42
LIT-19	1.78	0.28	1.50	0.16	0.000	0.020	0.25	0.00	1.00	1.00	4.00	0.25	2.26
LIT-19	2.26	0.35	1.91	0.15	0.000	0.020	0.25	0.00	1.00	1.00	4.00	0.25	2.86
LIT-19	2.58	0.28	2.30	0.11	0.000	0.020	0.25	0.00	1.00	1.00	4.00	0.25	3.27
LIT-19	0.78	0.11	0.67	0.14	0.000	0.020	0.30	0.00	1.00	1.00	3.33	0.30	0.75
LIT-19	1.79	0.22	1.57	0.12	0.000	0.020	0.30	0.00	1.00	1.00	3.33	0.30	1.71
LIT-19	2.68	0.30	2.38	0.11	0.000	0.020	0.30	0.00	1.00	1.00	3.33	0.30	2.56
LIT-19	3.19	0.17	3.02	0.05	0.000	0.020	0.30	0.00	1.00	1.00	3.33	0.30	3.05
LIT-19	0.05	0.05	0.00	0.97	0.000	0.048	0.07	0.00	1.00	1.00	14.29	0.07	0.69
LIT-19	0.11	0.11	0.00	0.96	0.000	0.048	0.07	0.00	1.00	1.00	14.29	0.07	1.49
LIT-19	0.20	0.19	0.01	0.96	0.000	0.048	0.07	0.00	1.00	1.00	14.29	0.07	2.67
LIT-19	0.26	0.24	0.01	0.95	0.000	0.048	0.07	0.00	1.00	1.00	14.29	0.07	3.47
LIT-19	0.36	0.35	0.02	0.96	0.000	0.048	0.07	0.00	1.00	1.00	14.29	0.07	4.91
LIT-19	0.43	0.40	0.03	0.93	0.000	0.048	0.07	0.00	1.00	1.00	14.29	0.07	5.84
LIT-19	0.46	0.42	0.04	0.90	0.000	0.048	0.07	0.00	1.00	1.00	14.29	0.07	6.26
LIT-19	0.06	0.06	0.01	0.90	0.000	0.048	0.08	0.00	1.00	1.00	12.50	0.08	0.67

Continued on next page

Table 5: Literature-Derived Performance Data for Drop-Type Inlets — Continued

ID-CODE	Q_A	Q_I	Q_O	Q_R	S_0	S_x	d_a	h_b	L_I	W_I	L_R	W_R	Fr
LIT-19	0.15	0.13	0.01	0.91	0.000	0.048	0.08	0.00	1.00	1.00	12.50	0.08	1.50
LIT-19	0.23	0.20	0.03	0.88	0.000	0.048	0.08	0.00	1.00	1.00	12.50	0.08	2.39
LIT-19	0.35	0.30	0.05	0.86	0.000	0.048	0.08	0.00	1.00	1.00	12.50	0.08	3.60
LIT-19	0.45	0.39	0.06	0.86	0.000	0.048	0.08	0.00	1.00	1.00	12.50	0.08	4.60
LIT-19	0.51	0.43	0.07	0.86	0.000	0.048	0.08	0.00	1.00	1.00	12.50	0.08	5.21
LIT-19	0.55	0.45	0.10	0.81	0.000	0.048	0.08	0.00	1.00	1.00	12.50	0.08	5.69
LIT-19	0.09	0.07	0.01	0.84	0.000	0.048	0.09	0.00	1.00	1.00	11.11	0.09	0.69
LIT-19	0.24	0.20	0.04	0.82	0.000	0.048	0.09	0.00	1.00	1.00	11.11	0.09	1.98
LIT-19	0.32	0.26	0.06	0.81	0.000	0.048	0.09	0.00	1.00	1.00	11.11	0.09	2.58
LIT-19	0.48	0.38	0.09	0.81	0.000	0.048	0.09	0.00	1.00	1.00	11.11	0.09	3.87
LIT-19	0.60	0.47	0.13	0.78	0.000	0.048	0.09	0.00	1.00	1.00	11.11	0.09	4.84
LIT-19	0.64	0.49	0.15	0.76	0.000	0.048	0.09	0.00	1.00	1.00	11.11	0.09	5.19
LIT-19	0.10	0.08	0.02	0.76	0.000	0.048	0.10	0.00	1.00	1.00	10.00	0.10	0.68
LIT-19	0.19	0.15	0.05	0.75	0.000	0.048	0.10	0.00	1.00	1.00	10.00	0.10	1.29
LIT-19	0.34	0.25	0.08	0.75	0.000	0.048	0.10	0.00	1.00	1.00	10.00	0.10	2.23
LIT-19	0.49	0.36	0.13	0.73	0.000	0.048	0.10	0.00	1.00	1.00	10.00	0.10	3.28
LIT-19	0.66	0.48	0.18	0.72	0.000	0.048	0.10	0.00	1.00	1.00	10.00	0.10	4.38
LIT-19	0.73	0.49	0.24	0.68	0.000	0.048	0.10	0.00	1.00	1.00	10.00	0.10	4.84
LIT-19	0.12	0.09	0.03	0.74	0.000	0.048	0.11	0.00	1.00	1.00	9.09	0.11	0.68
LIT-19	0.20	0.15	0.05	0.73	0.000	0.048	0.11	0.00	1.00	1.00	9.09	0.11	1.12
LIT-19	0.33	0.23	0.09	0.71	0.000	0.048	0.11	0.00	1.00	1.00	9.09	0.11	1.82
LIT-19	0.57	0.40	0.17	0.70	0.000	0.048	0.11	0.00	1.00	1.00	9.09	0.11	3.18
LIT-19	0.73	0.50	0.23	0.69	0.000	0.048	0.11	0.00	1.00	1.00	9.09	0.11	4.08
LIT-19	0.81	0.52	0.29	0.65	0.000	0.048	0.11	0.00	1.00	1.00	9.09	0.11	4.49
LIT-19	0.14	0.10	0.04	0.70	0.000	0.048	0.12	0.00	1.00	1.00	8.33	0.12	0.68
LIT-19	0.30	0.20	0.09	0.69	0.000	0.048	0.12	0.00	1.00	1.00	8.33	0.12	1.41
LIT-19	0.49	0.33	0.16	0.67	0.000	0.048	0.12	0.00	1.00	1.00	8.33	0.12	2.33
LIT-19	0.59	0.38	0.21	0.65	0.000	0.048	0.12	0.00	1.00	1.00	8.33	0.12	2.78
LIT-19	0.72	0.47	0.25	0.65	0.000	0.048	0.12	0.00	1.00	1.00	8.33	0.12	3.41
LIT-19	0.81	0.52	0.30	0.64	0.000	0.048	0.12	0.00	1.00	1.00	8.33	0.12	3.84
LIT-19	0.87	0.53	0.34	0.61	0.000	0.048	0.12	0.00	1.00	1.00	8.33	0.12	4.12
LIT-19	0.19	0.12	0.07	0.64	0.000	0.048	0.14	0.00	1.00	1.00	7.14	0.14	0.67
LIT-19	0.31	0.20	0.11	0.64	0.000	0.048	0.14	0.00	1.00	1.00	7.14	0.14	1.10
LIT-19	0.33	0.21	0.12	0.63	0.000	0.048	0.14	0.00	1.00	1.00	7.14	0.14	1.19
LIT-19	0.55	0.34	0.21	0.62	0.000	0.048	0.14	0.00	1.00	1.00	7.14	0.14	2.00
LIT-19	0.59	0.36	0.23	0.61	0.000	0.048	0.14	0.00	1.00	1.00	7.14	0.14	2.11
LIT-19	0.79	0.48	0.31	0.61	0.000	0.048	0.14	0.00	1.00	1.00	7.14	0.14	2.84
LIT-19	0.95	0.56	0.39	0.59	0.000	0.048	0.14	0.00	1.00	1.00	7.14	0.14	3.43
LIT-19	1.06	0.59	0.47	0.55	0.000	0.048	0.14	0.00	1.00	1.00	7.14	0.14	3.81

Continued on next page

Table 5: Literature-Derived Performance Data for Drop-Type Inlets — Continued

ID-CODE	Q_A	Q_I	Q_O	Q_R	S_0	S_x	d_a	h_b	L_I	W_I	L_R	W_R	Fr
LIT-19	0.23	0.13	0.10	0.57	0.000	0.048	0.16	0.00	1.00	1.00	6.25	0.16	0.65
LIT-19	0.38	0.21	0.17	0.56	0.000	0.048	0.16	0.00	1.00	1.00	6.25	0.16	1.10
LIT-19	0.52	0.29	0.23	0.56	0.000	0.048	0.16	0.00	1.00	1.00	6.25	0.16	1.50
LIT-19	0.83	0.45	0.38	0.54	0.000	0.048	0.16	0.00	1.00	1.00	6.25	0.16	2.37
LIT-19	1.08	0.56	0.51	0.52	0.000	0.048	0.16	0.00	1.00	1.00	6.25	0.16	3.08
LIT-19	1.19	0.59	0.60	0.50	0.000	0.048	0.16	0.00	1.00	1.00	6.25	0.16	3.40
LIT-19	0.29	0.15	0.14	0.52	0.000	0.048	0.18	0.00	1.00	1.00	5.56	0.18	0.68
LIT-19	0.49	0.25	0.24	0.51	0.000	0.048	0.18	0.00	1.00	1.00	5.56	0.18	1.16
LIT-19	0.54	0.27	0.27	0.50	0.000	0.048	0.18	0.00	1.00	1.00	5.56	0.18	1.27
LIT-19	0.86	0.43	0.43	0.50	0.000	0.048	0.18	0.00	1.00	1.00	5.56	0.18	2.03
LIT-19	1.15	0.55	0.59	0.48	0.000	0.048	0.18	0.00	1.00	1.00	5.56	0.18	2.69
LIT-19	1.33	0.58	0.75	0.44	0.000	0.048	0.18	0.00	1.00	1.00	5.56	0.18	3.13
LIT-19	0.35	0.16	0.18	0.47	0.000	0.048	0.20	0.00	1.00	1.00	5.00	0.20	0.68
LIT-19	0.61	0.28	0.33	0.46	0.000	0.048	0.20	0.00	1.00	1.00	5.00	0.20	1.20
LIT-19	0.69	0.32	0.37	0.47	0.000	0.048	0.20	0.00	1.00	1.00	5.00	0.20	1.35
LIT-19	0.95	0.43	0.52	0.46	0.000	0.048	0.20	0.00	1.00	1.00	5.00	0.20	1.86
LIT-19	1.25	0.55	0.70	0.44	0.000	0.048	0.20	0.00	1.00	1.00	5.00	0.20	2.46
LIT-19	1.44	0.57	0.86	0.40	0.000	0.048	0.20	0.00	1.00	1.00	5.00	0.20	2.82
LIT-19	0.51	0.23	0.29	0.44	0.000	0.048	0.25	0.00	1.00	1.00	4.00	0.25	0.70
LIT-19	0.89	0.37	0.52	0.42	0.000	0.048	0.25	0.00	1.00	1.00	4.00	0.25	1.21
LIT-19	1.25	0.50	0.74	0.40	0.000	0.048	0.25	0.00	1.00	1.00	4.00	0.25	1.70
LIT-19	1.61	0.66	0.95	0.41	0.000	0.048	0.25	0.00	1.00	1.00	4.00	0.25	2.19
LIT-19	1.84	0.67	1.17	0.36	0.000	0.048	0.25	0.00	1.00	1.00	4.00	0.25	2.51
LIT-19	0.70	0.28	0.42	0.40	0.000	0.048	0.30	0.00	1.00	1.00	3.33	0.30	0.71
LIT-19	1.20	0.45	0.75	0.37	0.000	0.048	0.30	0.00	1.00	1.00	3.33	0.30	1.22
LIT-19	1.49	0.58	0.91	0.39	0.000	0.048	0.30	0.00	1.00	1.00	3.33	0.30	1.51
LIT-19	1.91	0.71	1.20	0.37	0.000	0.048	0.30	0.00	1.00	1.00	3.33	0.30	1.93
LIT-19	2.21	0.70	1.51	0.32	0.000	0.048	0.30	0.00	1.00	1.00	3.33	0.30	2.24
LIT-20	0.01	0.01	0.00	0.94	0.000	0.020	0.03	0.00	1.00	1.00	33.33	0.03	0.68
LIT-20	0.04	0.04	0.00	0.93	0.000	0.020	0.03	0.00	1.00	1.00	33.33	0.03	2.09
LIT-20	0.07	0.06	0.01	0.92	0.000	0.020	0.03	0.00	1.00	1.00	33.33	0.03	3.17
LIT-20	0.09	0.08	0.01	0.90	0.000	0.020	0.03	0.00	1.00	1.00	33.33	0.03	4.34
LIT-20	0.12	0.10	0.01	0.90	0.000	0.020	0.03	0.00	1.00	1.00	33.33	0.03	5.53
LIT-20	0.14	0.13	0.02	0.89	0.000	0.020	0.03	0.00	1.00	1.00	33.33	0.03	6.79
LIT-20	0.18	0.16	0.02	0.88	0.000	0.020	0.03	0.00	1.00	1.00	33.33	0.03	8.44
LIT-20	0.19	0.16	0.03	0.84	0.000	0.020	0.03	0.00	1.00	1.00	33.33	0.03	8.84
LIT-20	0.02	0.02	0.00	0.80	0.000	0.020	0.04	0.00	1.00	1.00	25.00	0.04	0.66
LIT-20	0.06	0.04	0.01	0.78	0.000	0.020	0.04	0.00	1.00	1.00	25.00	0.04	1.51
LIT-20	0.09	0.07	0.02	0.79	0.000	0.020	0.04	0.00	1.00	1.00	25.00	0.04	2.35

Continued on next page

Table 5: Literature-Derived Performance Data for Drop-Type Inlets — Continued

ID-CODE	Q_A	Q_I	Q_O	Q_R	S_0	S_x	d_a	h_b	L_I	W_I	L_R	W_R	Fr
LIT-20	0.14	0.11	0.03	0.77	0.000	0.020	0.04	0.00	1.00	1.00	25.00	0.04	3.73
LIT-20	0.20	0.15	0.05	0.76	0.000	0.020	0.04	0.00	1.00	1.00	25.00	0.04	5.25
LIT-20	0.23	0.18	0.06	0.76	0.000	0.020	0.04	0.00	1.00	1.00	25.00	0.04	6.20
LIT-20	0.27	0.20	0.07	0.75	0.000	0.020	0.04	0.00	1.00	1.00	25.00	0.04	7.10
LIT-20	0.29	0.21	0.08	0.73	0.000	0.020	0.04	0.00	1.00	1.00	25.00	0.04	7.68
LIT-20	0.31	0.20	0.11	0.66	0.000	0.020	0.04	0.00	1.00	1.00	25.00	0.04	8.17
LIT-20	0.04	0.03	0.01	0.69	0.000	0.020	0.05	0.00	1.00	1.00	20.00	0.05	0.70
LIT-20	0.11	0.07	0.03	0.69	0.000	0.020	0.05	0.00	1.00	1.00	20.00	0.05	1.89
LIT-20	0.16	0.11	0.05	0.67	0.000	0.020	0.05	0.00	1.00	1.00	20.00	0.05	2.79
LIT-20	0.21	0.14	0.07	0.67	0.000	0.020	0.05	0.00	1.00	1.00	20.00	0.05	3.75
LIT-20	0.27	0.18	0.09	0.66	0.000	0.020	0.05	0.00	1.00	1.00	20.00	0.05	4.80
LIT-20	0.33	0.21	0.11	0.66	0.000	0.020	0.05	0.00	1.00	1.00	20.00	0.05	5.75
LIT-20	0.37	0.24	0.13	0.64	0.000	0.020	0.05	0.00	1.00	1.00	20.00	0.05	6.46
LIT-20	0.42	0.24	0.18	0.57	0.000	0.020	0.05	0.00	1.00	1.00	20.00	0.05	7.40
LIT-20	0.05	0.03	0.02	0.60	0.000	0.020	0.06	0.00	1.00	1.00	16.67	0.06	0.70
LIT-20	0.17	0.10	0.07	0.59	0.000	0.020	0.06	0.00	1.00	1.00	16.67	0.06	2.21
LIT-20	0.26	0.15	0.10	0.59	0.000	0.020	0.06	0.00	1.00	1.00	16.67	0.06	3.28
LIT-20	0.34	0.19	0.15	0.56	0.000	0.020	0.06	0.00	1.00	1.00	16.67	0.06	4.33
LIT-20	0.42	0.24	0.18	0.57	0.000	0.020	0.06	0.00	1.00	1.00	16.67	0.06	5.31
LIT-20	0.46	0.25	0.21	0.55	0.000	0.020	0.06	0.00	1.00	1.00	16.67	0.06	5.83
LIT-20	0.53	0.24	0.29	0.46	0.000	0.020	0.06	0.00	1.00	1.00	16.67	0.06	6.72
LIT-20	0.07	0.04	0.03	0.53	0.000	0.020	0.07	0.00	1.00	1.00	14.29	0.07	0.71
LIT-20	0.17	0.09	0.09	0.51	0.000	0.020	0.07	0.00	1.00	1.00	14.29	0.07	1.71
LIT-20	0.25	0.13	0.12	0.51	0.000	0.020	0.07	0.00	1.00	1.00	14.29	0.07	2.40
LIT-20	0.30	0.15	0.15	0.49	0.000	0.020	0.07	0.00	1.00	1.00	14.29	0.07	2.92
LIT-20	0.36	0.18	0.18	0.50	0.000	0.020	0.07	0.00	1.00	1.00	14.29	0.07	3.57
LIT-20	0.43	0.21	0.22	0.49	0.000	0.020	0.07	0.00	1.00	1.00	14.29	0.07	4.20
LIT-20	0.50	0.24	0.26	0.48	0.000	0.020	0.07	0.00	1.00	1.00	14.29	0.07	4.93
LIT-20	0.56	0.25	0.31	0.45	0.000	0.020	0.07	0.00	1.00	1.00	14.29	0.07	5.52
LIT-20	0.60	0.26	0.35	0.42	0.000	0.020	0.07	0.00	1.00	1.00	14.29	0.07	5.91
LIT-20	0.63	0.24	0.39	0.38	0.000	0.020	0.07	0.00	1.00	1.00	14.29	0.07	6.12
LIT-20	0.09	0.04	0.05	0.47	0.000	0.020	0.08	0.00	1.00	1.00	12.50	0.08	0.70
LIT-20	0.19	0.09	0.10	0.47	0.000	0.020	0.08	0.00	1.00	1.00	12.50	0.08	1.48
LIT-20	0.27	0.12	0.15	0.45	0.000	0.020	0.08	0.00	1.00	1.00	12.50	0.08	2.11
LIT-20	0.36	0.16	0.20	0.45	0.000	0.020	0.08	0.00	1.00	1.00	12.50	0.08	2.83
LIT-20	0.46	0.20	0.26	0.44	0.000	0.020	0.08	0.00	1.00	1.00	12.50	0.08	3.58
LIT-20	0.57	0.25	0.33	0.43	0.000	0.020	0.08	0.00	1.00	1.00	12.50	0.08	4.49
LIT-20	0.63	0.27	0.37	0.42	0.000	0.020	0.08	0.00	1.00	1.00	12.50	0.08	4.95
LIT-20	0.72	0.25	0.48	0.34	0.000	0.020	0.08	0.00	1.00	1.00	12.50	0.08	5.64

Continued on next page

Table 5: Literature-Derived Performance Data for Drop-Type Inlets — Continued

ID-CODE	Q_A	Q_I	Q_O	Q_R	S_0	S_x	d_a	h_b	L_I	W_I	L_R	W_R	Fr
LIT-20	0.11	0.05	0.06	0.44	0.000	0.020	0.09	0.00	1.00	1.00	11.11	0.09	0.70
LIT-20	0.25	0.11	0.15	0.43	0.000	0.020	0.09	0.00	1.00	1.00	11.11	0.09	1.64
LIT-20	0.38	0.16	0.22	0.41	0.000	0.020	0.09	0.00	1.00	1.00	11.11	0.09	2.42
LIT-20	0.53	0.21	0.31	0.41	0.000	0.020	0.09	0.00	1.00	1.00	11.11	0.09	3.38
LIT-20	0.65	0.26	0.40	0.39	0.000	0.020	0.09	0.00	1.00	1.00	11.11	0.09	4.20
LIT-20	0.74	0.27	0.47	0.37	0.000	0.020	0.09	0.00	1.00	1.00	11.11	0.09	4.77
LIT-20	0.82	0.27	0.55	0.33	0.000	0.020	0.09	0.00	1.00	1.00	11.11	0.09	5.24
LIT-20	0.13	0.05	0.07	0.41	0.000	0.020	0.10	0.00	1.00	1.00	10.00	0.10	0.68
LIT-20	0.25	0.10	0.15	0.40	0.000	0.020	0.10	0.00	1.00	1.00	10.00	0.10	1.33
LIT-20	0.30	0.12	0.18	0.39	0.000	0.020	0.10	0.00	1.00	1.00	10.00	0.10	1.61
LIT-20	0.39	0.15	0.24	0.39	0.000	0.020	0.10	0.00	1.00	1.00	10.00	0.10	2.09
LIT-20	0.53	0.20	0.33	0.38	0.000	0.020	0.10	0.00	1.00	1.00	10.00	0.10	2.86
LIT-20	0.68	0.25	0.43	0.37	0.000	0.020	0.10	0.00	1.00	1.00	10.00	0.10	3.70
LIT-20	0.76	0.28	0.48	0.36	0.000	0.020	0.10	0.00	1.00	1.00	10.00	0.10	4.10
LIT-20	0.84	0.28	0.56	0.33	0.000	0.020	0.10	0.00	1.00	1.00	10.00	0.10	4.54
LIT-20	0.94	0.25	0.69	0.27	0.000	0.020	0.10	0.00	1.00	1.00	10.00	0.10	5.09
LIT-20	0.14	0.05	0.09	0.37	0.000	0.020	0.11	0.00	1.00	1.00	9.09	0.11	0.67
LIT-20	0.29	0.10	0.18	0.36	0.000	0.020	0.11	0.00	1.00	1.00	9.09	0.11	1.33
LIT-20	0.40	0.14	0.26	0.35	0.000	0.020	0.11	0.00	1.00	1.00	9.09	0.11	1.85
LIT-20	0.54	0.19	0.34	0.36	0.000	0.020	0.11	0.00	1.00	1.00	9.09	0.11	2.48
LIT-20	0.69	0.23	0.45	0.34	0.000	0.020	0.11	0.00	1.00	1.00	9.09	0.11	3.18
LIT-20	0.82	0.27	0.55	0.33	0.000	0.020	0.11	0.00	1.00	1.00	9.09	0.11	3.80
LIT-20	0.93	0.28	0.65	0.30	0.000	0.020	0.11	0.00	1.00	1.00	9.09	0.11	4.30
LIT-20	1.02	0.26	0.76	0.26	0.000	0.020	0.11	0.00	1.00	1.00	9.09	0.11	4.74
LIT-20	0.17	0.06	0.12	0.33	0.000	0.020	0.12	0.00	1.00	1.00	8.33	0.12	0.69
LIT-20	0.39	0.13	0.27	0.32	0.000	0.020	0.12	0.00	1.00	1.00	8.33	0.12	1.58
LIT-20	0.59	0.18	0.41	0.31	0.000	0.020	0.12	0.00	1.00	1.00	8.33	0.12	2.37
LIT-20	0.75	0.23	0.52	0.31	0.000	0.020	0.12	0.00	1.00	1.00	8.33	0.12	3.01
LIT-20	0.90	0.26	0.63	0.29	0.000	0.020	0.12	0.00	1.00	1.00	8.33	0.12	3.61
LIT-20	1.03	0.28	0.75	0.27	0.000	0.020	0.12	0.00	1.00	1.00	8.33	0.12	4.14
LIT-20	1.14	0.23	0.91	0.21	0.000	0.020	0.12	0.00	1.00	1.00	8.33	0.12	4.60
LIT-20	0.23	0.07	0.16	0.29	0.000	0.020	0.14	0.00	1.00	1.00	7.14	0.14	0.73
LIT-20	0.41	0.11	0.29	0.28	0.000	0.020	0.14	0.00	1.00	1.00	7.14	0.14	1.28
LIT-20	0.63	0.18	0.45	0.28	0.000	0.020	0.14	0.00	1.00	1.00	7.14	0.14	1.97
LIT-20	0.82	0.22	0.60	0.27	0.000	0.020	0.14	0.00	1.00	1.00	7.14	0.14	2.59
LIT-20	1.00	0.26	0.74	0.26	0.000	0.020	0.14	0.00	1.00	1.00	7.14	0.14	3.14
LIT-20	1.15	0.28	0.86	0.25	0.000	0.020	0.14	0.00	1.00	1.00	7.14	0.14	3.61
LIT-20	1.31	0.23	1.09	0.17	0.000	0.020	0.14	0.00	1.00	1.00	7.14	0.14	4.13
LIT-20	0.28	0.07	0.20	0.26	0.000	0.020	0.16	0.00	1.00	1.00	6.25	0.16	0.70

Continued on next page

Table 5: Literature-Derived Performance Data for Drop-Type Inlets — Continued

ID-CODE	Q_A	Q_I	Q_O	Q_R	S_0	S_x	d_a	h_b	L_I	W_I	L_R	W_R	Fr
LIT-20	0.42	0.11	0.31	0.25	0.000	0.020	0.16	0.00	1.00	1.00	6.25	0.16	1.07
LIT-20	0.66	0.16	0.49	0.25	0.000	0.020	0.16	0.00	1.00	1.00	6.25	0.16	1.68
LIT-20	0.90	0.22	0.68	0.24	0.000	0.020	0.16	0.00	1.00	1.00	6.25	0.16	2.29
LIT-20	1.13	0.27	0.86	0.24	0.000	0.020	0.16	0.00	1.00	1.00	6.25	0.16	2.87
LIT-20	1.28	0.28	1.00	0.22	0.000	0.020	0.16	0.00	1.00	1.00	6.25	0.16	3.25
LIT-20	1.54	0.22	1.31	0.15	0.000	0.020	0.16	0.00	1.00	1.00	6.25	0.16	3.91
LIT-20	0.34	0.08	0.26	0.23	0.000	0.020	0.18	0.00	1.00	1.00	5.56	0.18	0.72
LIT-20	0.67	0.15	0.52	0.23	0.000	0.020	0.18	0.00	1.00	1.00	5.56	0.18	1.42
LIT-20	0.99	0.22	0.77	0.22	0.000	0.020	0.18	0.00	1.00	1.00	5.56	0.18	2.09
LIT-20	1.31	0.28	1.03	0.21	0.000	0.020	0.18	0.00	1.00	1.00	5.56	0.18	2.76
LIT-20	1.48	0.28	1.20	0.19	0.000	0.020	0.18	0.00	1.00	1.00	5.56	0.18	3.13
LIT-20	1.74	0.21	1.53	0.12	0.000	0.020	0.18	0.00	1.00	1.00	5.56	0.18	3.69
LIT-20	0.40	0.08	0.32	0.21	0.000	0.020	0.20	0.00	1.00	1.00	5.00	0.20	0.72
LIT-20	0.78	0.16	0.62	0.21	0.000	0.020	0.20	0.00	1.00	1.00	5.00	0.20	1.40
LIT-20	1.02	0.20	0.82	0.20	0.000	0.020	0.20	0.00	1.00	1.00	5.00	0.20	1.82
LIT-20	1.34	0.25	1.09	0.19	0.000	0.020	0.20	0.00	1.00	1.00	5.00	0.20	2.40
LIT-20	1.49	0.27	1.22	0.18	0.000	0.020	0.20	0.00	1.00	1.00	5.00	0.20	2.67
LIT-20	1.69	0.29	1.40	0.17	0.000	0.020	0.20	0.00	1.00	1.00	5.00	0.20	3.03
LIT-20	1.86	0.24	1.62	0.13	0.000	0.020	0.20	0.00	1.00	1.00	5.00	0.20	3.34
LIT-20	0.58	0.10	0.48	0.17	0.000	0.020	0.25	0.00	1.00	1.00	4.00	0.25	0.73
LIT-20	0.85	0.15	0.70	0.17	0.000	0.020	0.25	0.00	1.00	1.00	4.00	0.25	1.08
LIT-20	1.32	0.21	1.11	0.16	0.000	0.020	0.25	0.00	1.00	1.00	4.00	0.25	1.67
LIT-20	1.78	0.29	1.49	0.16	0.000	0.020	0.25	0.00	1.00	1.00	4.00	0.25	2.25
LIT-20	2.05	0.27	1.78	0.13	0.000	0.020	0.25	0.00	1.00	1.00	4.00	0.25	2.60
LIT-20	2.30	0.27	2.03	0.12	0.000	0.020	0.25	0.00	1.00	1.00	4.00	0.25	2.91
LIT-20	2.49	0.22	2.27	0.09	0.000	0.020	0.25	0.00	1.00	1.00	4.00	0.25	3.16
LIT-20	0.75	0.10	0.65	0.13	0.000	0.020	0.30	0.00	1.00	1.00	3.33	0.30	0.72
LIT-20	1.37	0.17	1.20	0.13	0.000	0.020	0.30	0.00	1.00	1.00	3.33	0.30	1.31
LIT-20	1.81	0.22	1.59	0.12	0.000	0.020	0.30	0.00	1.00	1.00	3.33	0.30	1.73
LIT-20	2.10	0.22	1.88	0.10	0.000	0.020	0.30	0.00	1.00	1.00	3.33	0.30	2.00
LIT-20	2.49	0.26	2.22	0.11	0.000	0.020	0.30	0.00	1.00	1.00	3.33	0.30	2.38
LIT-20	2.67	0.19	2.47	0.07	0.000	0.020	0.30	0.00	1.00	1.00	3.33	0.30	2.55
LIT-20	3.00	0.12	2.88	0.04	0.000	0.020	0.30	0.00	1.00	1.00	3.33	0.30	2.87
LIT-20	0.05	0.05	0.00	0.97	0.000	0.048	0.07	0.00	1.00	1.00	14.29	0.07	0.71
LIT-20	0.10	0.10	0.00	0.97	0.000	0.048	0.07	0.00	1.00	1.00	14.29	0.07	1.35
LIT-20	0.18	0.17	0.01	0.96	0.000	0.048	0.07	0.00	1.00	1.00	14.29	0.07	2.44
LIT-20	0.24	0.22	0.01	0.95	0.000	0.048	0.07	0.00	1.00	1.00	14.29	0.07	3.20
LIT-20	0.29	0.27	0.02	0.95	0.000	0.048	0.07	0.00	1.00	1.00	14.29	0.07	3.93
LIT-20	0.34	0.32	0.02	0.94	0.000	0.048	0.07	0.00	1.00	1.00	14.29	0.07	4.57

Continued on next page

Table 5: Literature-Derived Performance Data for Drop-Type Inlets — Continued

ID-CODE	Q_A	Q_I	Q_O	Q_R	S_0	S_x	d_a	h_b	L_I	W_I	L_R	W_R	Fr
LIT-20	0.38	0.36	0.02	0.94	0.000	0.048	0.07	0.00	1.00	1.00	14.29	0.07	5.23
LIT-20	0.42	0.39	0.03	0.92	0.000	0.048	0.07	0.00	1.00	1.00	14.29	0.07	5.70
LIT-20	0.45	0.40	0.05	0.89	0.000	0.048	0.07	0.00	1.00	1.00	14.29	0.07	6.07
LIT-20	0.07	0.06	0.01	0.89	0.000	0.048	0.08	0.00	1.00	1.00	12.50	0.08	0.69
LIT-20	0.16	0.14	0.02	0.88	0.000	0.048	0.08	0.00	1.00	1.00	12.50	0.08	1.62
LIT-20	0.25	0.22	0.03	0.88	0.000	0.048	0.08	0.00	1.00	1.00	12.50	0.08	2.61
LIT-20	0.33	0.29	0.04	0.87	0.000	0.048	0.08	0.00	1.00	1.00	12.50	0.08	3.39
LIT-20	0.40	0.34	0.05	0.87	0.000	0.048	0.08	0.00	1.00	1.00	12.50	0.08	4.06
LIT-20	0.45	0.38	0.07	0.85	0.000	0.048	0.08	0.00	1.00	1.00	12.50	0.08	4.57
LIT-20	0.48	0.41	0.07	0.85	0.000	0.048	0.08	0.00	1.00	1.00	12.50	0.08	4.94
LIT-20	0.51	0.42	0.09	0.82	0.000	0.048	0.08	0.00	1.00	1.00	12.50	0.08	5.23
LIT-20	0.54	0.43	0.11	0.80	0.000	0.048	0.08	0.00	1.00	1.00	12.50	0.08	5.56
LIT-20	0.09	0.07	0.01	0.83	0.000	0.048	0.09	0.00	1.00	1.00	11.11	0.09	0.71
LIT-20	0.15	0.12	0.03	0.83	0.000	0.048	0.09	0.00	1.00	1.00	11.11	0.09	1.20
LIT-20	0.25	0.20	0.05	0.82	0.000	0.048	0.09	0.00	1.00	1.00	11.11	0.09	2.01
LIT-20	0.34	0.27	0.06	0.81	0.000	0.048	0.09	0.00	1.00	1.00	11.11	0.09	2.73
LIT-20	0.41	0.32	0.08	0.79	0.000	0.048	0.09	0.00	1.00	1.00	11.11	0.09	3.31
LIT-20	0.50	0.40	0.10	0.80	0.000	0.048	0.09	0.00	1.00	1.00	11.11	0.09	4.04
LIT-20	0.55	0.43	0.12	0.78	0.000	0.048	0.09	0.00	1.00	1.00	11.11	0.09	4.50
LIT-20	0.59	0.45	0.14	0.77	0.000	0.048	0.09	0.00	1.00	1.00	11.11	0.09	4.80
LIT-20	0.63	0.45	0.18	0.72	0.000	0.048	0.09	0.00	1.00	1.00	11.11	0.09	5.09
LIT-20	0.10	0.08	0.02	0.76	0.000	0.048	0.10	0.00	1.00	1.00	10.00	0.10	0.69
LIT-20	0.19	0.14	0.05	0.76	0.000	0.048	0.10	0.00	1.00	1.00	10.00	0.10	1.24
LIT-20	0.31	0.23	0.08	0.74	0.000	0.048	0.10	0.00	1.00	1.00	10.00	0.10	2.09
LIT-20	0.40	0.29	0.11	0.73	0.000	0.048	0.10	0.00	1.00	1.00	10.00	0.10	2.65
LIT-20	0.45	0.33	0.13	0.72	0.000	0.048	0.10	0.00	1.00	1.00	10.00	0.10	3.00
LIT-20	0.53	0.39	0.14	0.73	0.000	0.048	0.10	0.00	1.00	1.00	10.00	0.10	3.52
LIT-20	0.61	0.43	0.18	0.70	0.000	0.048	0.10	0.00	1.00	1.00	10.00	0.10	4.05
LIT-20	0.66	0.46	0.21	0.69	0.000	0.048	0.10	0.00	1.00	1.00	10.00	0.10	4.41
LIT-20	0.70	0.46	0.25	0.65	0.000	0.048	0.10	0.00	1.00	1.00	10.00	0.10	4.67
LIT-20	0.12	0.09	0.03	0.74	0.000	0.048	0.11	0.00	1.00	1.00	9.09	0.11	0.69
LIT-20	0.25	0.18	0.07	0.72	0.000	0.048	0.11	0.00	1.00	1.00	9.09	0.11	1.39
LIT-20	0.32	0.23	0.09	0.71	0.000	0.048	0.11	0.00	1.00	1.00	9.09	0.11	1.79
LIT-20	0.43	0.30	0.13	0.69	0.000	0.048	0.11	0.00	1.00	1.00	9.09	0.11	2.40
LIT-20	0.54	0.37	0.17	0.69	0.000	0.048	0.11	0.00	1.00	1.00	9.09	0.11	2.98
LIT-20	0.62	0.43	0.19	0.69	0.000	0.048	0.11	0.00	1.00	1.00	9.09	0.11	3.47
LIT-20	0.69	0.47	0.22	0.67	0.000	0.048	0.11	0.00	1.00	1.00	9.09	0.11	3.84
LIT-20	0.74	0.49	0.26	0.65	0.000	0.048	0.11	0.00	1.00	1.00	9.09	0.11	4.13
LIT-20	0.78	0.49	0.29	0.62	0.000	0.048	0.11	0.00	1.00	1.00	9.09	0.11	4.33

Continued on next page

Table 5: Literature-Derived Performance Data for Drop-Type Inlets — Continued

ID-CODE	Q_A	Q_I	Q_O	Q_R	S_0	S_x	d_a	h_b	L_I	W_I	L_R	W_R	Fr
LIT-20	0.15	0.10	0.04	0.69	0.000	0.048	0.12	0.00	1.00	1.00	8.33	0.12	0.70
LIT-20	0.24	0.16	0.08	0.69	0.000	0.048	0.12	0.00	1.00	1.00	8.33	0.12	1.14
LIT-20	0.33	0.22	0.11	0.67	0.000	0.048	0.12	0.00	1.00	1.00	8.33	0.12	1.56
LIT-20	0.52	0.34	0.17	0.66	0.000	0.048	0.12	0.00	1.00	1.00	8.33	0.12	2.45
LIT-20	0.64	0.42	0.23	0.65	0.000	0.048	0.12	0.00	1.00	1.00	8.33	0.12	3.04
LIT-20	0.72	0.47	0.26	0.65	0.000	0.048	0.12	0.00	1.00	1.00	8.33	0.12	3.43
LIT-20	0.76	0.48	0.28	0.63	0.000	0.048	0.12	0.00	1.00	1.00	8.33	0.12	3.62
LIT-20	0.84	0.50	0.35	0.59	0.000	0.048	0.12	0.00	1.00	1.00	8.33	0.12	4.00
LIT-20	0.19	0.12	0.07	0.63	0.000	0.048	0.14	0.00	1.00	1.00	7.14	0.14	0.69
LIT-20	0.38	0.24	0.15	0.62	0.000	0.048	0.14	0.00	1.00	1.00	7.14	0.14	1.38
LIT-20	0.52	0.32	0.20	0.61	0.000	0.048	0.14	0.00	1.00	1.00	7.14	0.14	1.87
LIT-20	0.63	0.38	0.25	0.60	0.000	0.048	0.14	0.00	1.00	1.00	7.14	0.14	2.25
LIT-20	0.68	0.40	0.28	0.59	0.000	0.048	0.14	0.00	1.00	1.00	7.14	0.14	2.46
LIT-20	0.84	0.49	0.35	0.59	0.000	0.048	0.14	0.00	1.00	1.00	7.14	0.14	3.04
LIT-20	1.02	0.54	0.48	0.53	0.000	0.048	0.14	0.00	1.00	1.00	7.14	0.14	3.67
LIT-20	0.24	0.13	0.11	0.55	0.000	0.048	0.16	0.00	1.00	1.00	6.25	0.16	0.68
LIT-20	0.41	0.22	0.18	0.55	0.000	0.048	0.16	0.00	1.00	1.00	6.25	0.16	1.16
LIT-20	0.56	0.30	0.25	0.55	0.000	0.048	0.16	0.00	1.00	1.00	6.25	0.16	1.59
LIT-20	0.61	0.32	0.28	0.53	0.000	0.048	0.16	0.00	1.00	1.00	6.25	0.16	1.73
LIT-20	0.82	0.43	0.39	0.52	0.000	0.048	0.16	0.00	1.00	1.00	6.25	0.16	2.35
LIT-20	1.03	0.52	0.51	0.50	0.000	0.048	0.16	0.00	1.00	1.00	6.25	0.16	2.95
LIT-20	1.16	0.53	0.63	0.45	0.000	0.048	0.16	0.00	1.00	1.00	6.25	0.16	3.32
LIT-20	0.30	0.15	0.15	0.51	0.000	0.048	0.18	0.00	1.00	1.00	5.56	0.18	0.70
LIT-20	0.53	0.26	0.27	0.50	0.000	0.048	0.18	0.00	1.00	1.00	5.56	0.18	1.24
LIT-20	0.71	0.34	0.37	0.48	0.000	0.048	0.18	0.00	1.00	1.00	5.56	0.18	1.67
LIT-20	0.86	0.41	0.45	0.48	0.000	0.048	0.18	0.00	1.00	1.00	5.56	0.18	2.01
LIT-20	1.07	0.50	0.57	0.47	0.000	0.048	0.18	0.00	1.00	1.00	5.56	0.18	2.50
LIT-20	1.27	0.53	0.75	0.41	0.000	0.048	0.18	0.00	1.00	1.00	5.56	0.18	2.98
LIT-20	0.36	0.17	0.19	0.46	0.000	0.048	0.20	0.00	1.00	1.00	5.00	0.20	0.71
LIT-20	0.59	0.27	0.32	0.45	0.000	0.048	0.20	0.00	1.00	1.00	5.00	0.20	1.17
LIT-20	0.66	0.29	0.37	0.44	0.000	0.048	0.20	0.00	1.00	1.00	5.00	0.20	1.30
LIT-20	0.77	0.35	0.42	0.46	0.000	0.048	0.20	0.00	1.00	1.00	5.00	0.20	1.52
LIT-20	0.91	0.40	0.51	0.44	0.000	0.048	0.20	0.00	1.00	1.00	5.00	0.20	1.79
LIT-20	1.10	0.48	0.63	0.43	0.000	0.048	0.20	0.00	1.00	1.00	5.00	0.20	2.17
LIT-20	1.38	0.53	0.86	0.38	0.000	0.048	0.20	0.00	1.00	1.00	5.00	0.20	2.71
LIT-20	0.53	0.22	0.31	0.42	0.000	0.048	0.25	0.00	1.00	1.00	4.00	0.25	0.72
LIT-20	0.76	0.31	0.45	0.41	0.000	0.048	0.25	0.00	1.00	1.00	4.00	0.25	1.03
LIT-20	1.12	0.46	0.66	0.41	0.000	0.048	0.25	0.00	1.00	1.00	4.00	0.25	1.53
LIT-20	1.46	0.57	0.88	0.39	0.000	0.048	0.25	0.00	1.00	1.00	4.00	0.25	1.99

Continued on next page

Table 5: Literature-Derived Performance Data for Drop-Type Inlets — Continued

ID-CODE	Q_A	Q_I	Q_O	Q_R	S_0	S_x	d_a	h_b	L_I	W_I	L_R	W_R	Fr
LIT-20	1.84	0.63	1.21	0.34	0.000	0.048	0.25	0.00	1.00	1.00	4.00	0.25	2.50
LIT-20	0.71	0.27	0.44	0.38	0.000	0.048	0.30	0.00	1.00	1.00	3.33	0.30	0.72
LIT-20	1.03	0.40	0.63	0.38	0.000	0.048	0.30	0.00	1.00	1.00	3.33	0.30	1.04
LIT-20	1.26	0.46	0.81	0.36	0.000	0.048	0.30	0.00	1.00	1.00	3.33	0.30	1.28
LIT-20	1.61	0.57	1.03	0.36	0.000	0.048	0.30	0.00	1.00	1.00	3.33	0.30	1.63
LIT-20	2.18	0.64	1.54	0.29	0.000	0.048	0.30	0.00	1.00	1.00	3.33	0.30	2.21
LIT-21	0.03	0.02	0.00	0.83	0.000	0.020	0.04	0.00	1.00	1.00	25.00	0.04	0.67
LIT-21	0.07	0.06	0.01	0.83	0.000	0.020	0.04	0.00	1.00	1.00	25.00	0.04	1.94
LIT-21	0.14	0.12	0.02	0.83	0.000	0.020	0.04	0.00	1.00	1.00	25.00	0.04	3.74
LIT-21	0.21	0.17	0.04	0.81	0.000	0.020	0.04	0.00	1.00	1.00	25.00	0.04	5.66
LIT-21	0.26	0.21	0.06	0.79	0.000	0.020	0.04	0.00	1.00	1.00	25.00	0.04	7.03
LIT-21	0.30	0.22	0.08	0.73	0.000	0.020	0.04	0.00	1.00	1.00	25.00	0.04	7.97
LIT-21	0.04	0.03	0.01	0.73	0.000	0.020	0.05	0.00	1.00	1.00	20.00	0.05	0.68
LIT-21	0.12	0.09	0.03	0.72	0.000	0.020	0.05	0.00	1.00	1.00	20.00	0.05	2.16
LIT-21	0.23	0.16	0.07	0.71	0.000	0.020	0.05	0.00	1.00	1.00	20.00	0.05	4.08
LIT-21	0.32	0.22	0.10	0.70	0.000	0.020	0.05	0.00	1.00	1.00	20.00	0.05	5.61
LIT-21	0.39	0.24	0.15	0.62	0.000	0.020	0.05	0.00	1.00	1.00	20.00	0.05	6.84
LIT-21	0.05	0.03	0.02	0.64	0.000	0.020	0.06	0.00	1.00	1.00	16.67	0.06	0.68
LIT-21	0.18	0.11	0.07	0.62	0.000	0.020	0.06	0.00	1.00	1.00	16.67	0.06	2.35
LIT-21	0.33	0.20	0.13	0.61	0.000	0.020	0.06	0.00	1.00	1.00	16.67	0.06	4.27
LIT-21	0.45	0.25	0.19	0.57	0.000	0.020	0.06	0.00	1.00	1.00	16.67	0.06	5.71
LIT-21	0.48	0.25	0.23	0.52	0.000	0.020	0.06	0.00	1.00	1.00	16.67	0.06	6.17
LIT-21	0.07	0.04	0.03	0.56	0.000	0.020	0.07	0.00	1.00	1.00	14.29	0.07	0.67
LIT-21	0.18	0.10	0.08	0.56	0.000	0.020	0.07	0.00	1.00	1.00	14.29	0.07	1.79
LIT-21	0.31	0.17	0.14	0.54	0.000	0.020	0.07	0.00	1.00	1.00	14.29	0.07	3.02
LIT-21	0.41	0.22	0.19	0.53	0.000	0.020	0.07	0.00	1.00	1.00	14.29	0.07	4.04
LIT-21	0.50	0.25	0.24	0.51	0.000	0.020	0.07	0.00	1.00	1.00	14.29	0.07	4.85
LIT-21	0.53	0.26	0.28	0.48	0.000	0.020	0.07	0.00	1.00	1.00	14.29	0.07	5.20
LIT-21	0.57	0.24	0.33	0.42	0.000	0.020	0.07	0.00	1.00	1.00	14.29	0.07	5.56
LIT-21	0.08	0.04	0.04	0.50	0.000	0.020	0.08	0.00	1.00	1.00	12.50	0.08	0.66
LIT-21	0.27	0.13	0.14	0.49	0.000	0.020	0.08	0.00	1.00	1.00	12.50	0.08	2.09
LIT-21	0.42	0.20	0.22	0.48	0.000	0.020	0.08	0.00	1.00	1.00	12.50	0.08	3.32
LIT-21	0.58	0.27	0.31	0.46	0.000	0.020	0.08	0.00	1.00	1.00	12.50	0.08	4.53
LIT-21	0.64	0.28	0.36	0.43	0.000	0.020	0.08	0.00	1.00	1.00	12.50	0.08	4.99
LIT-21	0.70	0.26	0.45	0.37	0.000	0.020	0.08	0.00	1.00	1.00	12.50	0.08	5.49
LIT-21	0.10	0.05	0.06	0.45	0.000	0.020	0.09	0.00	1.00	1.00	11.11	0.09	0.64
LIT-21	0.32	0.14	0.18	0.44	0.000	0.020	0.09	0.00	1.00	1.00	11.11	0.09	2.03
LIT-21	0.47	0.20	0.26	0.44	0.000	0.020	0.09	0.00	1.00	1.00	11.11	0.09	3.00
LIT-21	0.62	0.26	0.36	0.42	0.000	0.020	0.09	0.00	1.00	1.00	11.11	0.09	4.01

Continued on next page

Table 5: Literature-Derived Performance Data for Drop-Type Inlets — Continued

ID-CODE	Q_A	Q_I	Q_O	Q_R	S_0	S_x	d_a	h_b	L_I	W_I	L_R	W_R	Fr
LIT-21	0.71	0.27	0.43	0.39	0.000	0.020	0.09	0.00	1.00	1.00	11.11	0.09	4.54
LIT-21	0.78	0.24	0.53	0.31	0.000	0.020	0.09	0.00	1.00	1.00	11.11	0.09	4.99
LIT-21	0.12	0.05	0.07	0.41	0.000	0.020	0.10	0.00	1.00	1.00	10.00	0.10	0.66
LIT-21	0.47	0.19	0.28	0.40	0.000	0.020	0.10	0.00	1.00	1.00	10.00	0.10	2.55
LIT-21	0.57	0.23	0.34	0.40	0.000	0.020	0.10	0.00	1.00	1.00	10.00	0.10	3.08
LIT-21	0.65	0.25	0.40	0.39	0.000	0.020	0.10	0.00	1.00	1.00	10.00	0.10	3.52
LIT-21	0.76	0.26	0.50	0.34	0.000	0.020	0.10	0.00	1.00	1.00	10.00	0.10	4.10
LIT-21	0.17	0.06	0.11	0.35	0.000	0.020	0.12	0.00	1.00	1.00	8.33	0.12	0.67
LIT-21	0.49	0.17	0.32	0.34	0.000	0.020	0.12	0.00	1.00	1.00	8.33	0.12	1.96
LIT-21	0.75	0.24	0.50	0.32	0.000	0.020	0.12	0.00	1.00	1.00	8.33	0.12	3.01
LIT-21	0.87	0.26	0.61	0.30	0.000	0.020	0.12	0.00	1.00	1.00	8.33	0.12	3.48
LIT-21	0.99	0.23	0.76	0.23	0.000	0.020	0.12	0.00	1.00	1.00	8.33	0.12	3.97
LIT-21	0.21	0.06	0.15	0.30	0.000	0.020	0.14	0.00	1.00	1.00	7.14	0.14	0.66
LIT-21	0.65	0.19	0.46	0.29	0.000	0.020	0.14	0.00	1.00	1.00	7.14	0.14	2.03
LIT-21	0.96	0.26	0.70	0.27	0.000	0.020	0.14	0.00	1.00	1.00	7.14	0.14	3.03
LIT-21	1.21	0.22	0.99	0.18	0.000	0.020	0.14	0.00	1.00	1.00	7.14	0.14	3.81
LIT-21	0.27	0.07	0.19	0.27	0.000	0.020	0.16	0.00	1.00	1.00	6.25	0.16	0.68
LIT-21	0.59	0.15	0.43	0.26	0.000	0.020	0.16	0.00	1.00	1.00	6.25	0.16	1.49
LIT-21	0.97	0.24	0.73	0.25	0.000	0.020	0.16	0.00	1.00	1.00	6.25	0.16	2.46
LIT-21	1.18	0.25	0.93	0.21	0.000	0.020	0.16	0.00	1.00	1.00	6.25	0.16	3.00
LIT-21	1.27	0.23	1.04	0.18	0.000	0.020	0.16	0.00	1.00	1.00	6.25	0.16	3.23
LIT-21	0.32	0.08	0.25	0.24	0.000	0.020	0.18	0.00	1.00	1.00	5.56	0.18	0.68
LIT-21	0.69	0.16	0.53	0.23	0.000	0.020	0.18	0.00	1.00	1.00	5.56	0.18	1.46
LIT-21	1.13	0.24	0.89	0.21	0.000	0.020	0.18	0.00	1.00	1.00	5.56	0.18	2.38
LIT-21	1.37	0.22	1.14	0.16	0.000	0.020	0.18	0.00	1.00	1.00	5.56	0.18	2.89
LIT-21	0.38	0.08	0.30	0.22	0.000	0.020	0.20	0.00	1.00	1.00	5.00	0.20	0.69
LIT-21	0.73	0.15	0.58	0.21	0.000	0.020	0.20	0.00	1.00	1.00	5.00	0.20	1.31
LIT-21	1.11	0.22	0.88	0.20	0.000	0.020	0.20	0.00	1.00	1.00	5.00	0.20	1.98
LIT-21	1.37	0.22	1.15	0.16	0.000	0.020	0.20	0.00	1.00	1.00	5.00	0.20	2.46
LIT-21	0.05	0.05	0.00	0.97	0.000	0.048	0.07	0.00	1.00	1.00	14.29	0.07	0.69
LIT-21	0.11	0.11	0.00	0.96	0.000	0.048	0.07	0.00	1.00	1.00	14.29	0.07	1.55
LIT-21	0.21	0.20	0.01	0.96	0.000	0.048	0.07	0.00	1.00	1.00	14.29	0.07	2.80
LIT-21	0.32	0.31	0.01	0.96	0.000	0.048	0.07	0.00	1.00	1.00	14.29	0.07	4.32
LIT-21	0.41	0.36	0.04	0.89	0.000	0.048	0.07	0.00	1.00	1.00	14.29	0.07	5.54
LIT-21	0.45	0.36	0.09	0.80	0.000	0.048	0.07	0.00	1.00	1.00	14.29	0.07	6.12
LIT-21	0.07	0.06	0.01	0.91	0.000	0.048	0.08	0.00	1.00	1.00	12.50	0.08	0.69
LIT-21	0.14	0.13	0.01	0.92	0.000	0.048	0.08	0.00	1.00	1.00	12.50	0.08	1.40
LIT-21	0.24	0.23	0.02	0.92	0.000	0.048	0.08	0.00	1.00	1.00	12.50	0.08	2.51
LIT-21	0.34	0.30	0.03	0.90	0.000	0.048	0.08	0.00	1.00	1.00	12.50	0.08	3.46

Continued on next page

Table 5: Literature-Derived Performance Data for Drop-Type Inlets — Continued

ID-CODE	Q_A	Q_I	Q_O	Q_R	S_0	S_x	d_a	h_b	L_I	W_I	L_R	W_R	Fr
LIT-21	0.43	0.38	0.05	0.87	0.000	0.048	0.08	0.00	1.00	1.00	12.50	0.08	4.46
LIT-21	0.48	0.39	0.09	0.81	0.000	0.048	0.08	0.00	1.00	1.00	12.50	0.08	4.95
LIT-21	0.53	0.38	0.15	0.72	0.000	0.048	0.08	0.00	1.00	1.00	12.50	0.08	5.48
LIT-21	0.08	0.07	0.01	0.86	0.000	0.048	0.09	0.00	1.00	1.00	11.11	0.09	0.68
LIT-21	0.19	0.17	0.03	0.86	0.000	0.048	0.09	0.00	1.00	1.00	11.11	0.09	1.56
LIT-21	0.31	0.26	0.04	0.86	0.000	0.048	0.09	0.00	1.00	1.00	11.11	0.09	2.48
LIT-21	0.43	0.36	0.07	0.84	0.000	0.048	0.09	0.00	1.00	1.00	11.11	0.09	3.51
LIT-21	0.51	0.42	0.09	0.83	0.000	0.048	0.09	0.00	1.00	1.00	11.11	0.09	4.13
LIT-21	0.65	0.40	0.25	0.61	0.000	0.048	0.09	0.00	1.00	1.00	11.11	0.09	5.31
LIT-21	0.10	0.08	0.02	0.81	0.000	0.048	0.10	0.00	1.00	1.00	10.00	0.10	0.69
LIT-21	0.26	0.21	0.05	0.81	0.000	0.048	0.10	0.00	1.00	1.00	10.00	0.10	1.75
LIT-21	0.31	0.25	0.06	0.80	0.000	0.048	0.10	0.00	1.00	1.00	10.00	0.10	2.05
LIT-21	0.38	0.30	0.08	0.80	0.000	0.048	0.10	0.00	1.00	1.00	10.00	0.10	2.52
LIT-21	0.45	0.36	0.09	0.80	0.000	0.048	0.10	0.00	1.00	1.00	10.00	0.10	2.97
LIT-21	0.59	0.44	0.14	0.76	0.000	0.048	0.10	0.00	1.00	1.00	10.00	0.10	3.89
LIT-21	0.67	0.45	0.22	0.67	0.000	0.048	0.10	0.00	1.00	1.00	10.00	0.10	4.45
LIT-21	0.74	0.40	0.34	0.54	0.000	0.048	0.10	0.00	1.00	1.00	10.00	0.10	4.93
LIT-21	0.13	0.10	0.03	0.77	0.000	0.048	0.11	0.00	1.00	1.00	9.09	0.11	0.70
LIT-21	0.20	0.15	0.05	0.77	0.000	0.048	0.11	0.00	1.00	1.00	9.09	0.11	1.12
LIT-21	0.37	0.28	0.09	0.76	0.000	0.048	0.11	0.00	1.00	1.00	9.09	0.11	2.06
LIT-21	0.55	0.41	0.14	0.74	0.000	0.048	0.11	0.00	1.00	1.00	9.09	0.11	3.06
LIT-21	0.65	0.47	0.19	0.72	0.000	0.048	0.11	0.00	1.00	1.00	9.09	0.11	3.63
LIT-21	0.73	0.47	0.26	0.64	0.000	0.048	0.11	0.00	1.00	1.00	9.09	0.11	4.06
LIT-21	0.79	0.44	0.35	0.55	0.000	0.048	0.11	0.00	1.00	1.00	9.09	0.11	4.41
LIT-21	0.15	0.11	0.04	0.71	0.000	0.048	0.12	0.00	1.00	1.00	8.33	0.12	0.70
LIT-21	0.33	0.23	0.10	0.71	0.000	0.048	0.12	0.00	1.00	1.00	8.33	0.12	1.56
LIT-21	0.44	0.31	0.13	0.70	0.000	0.048	0.12	0.00	1.00	1.00	8.33	0.12	2.09
LIT-21	0.55	0.38	0.16	0.70	0.000	0.048	0.12	0.00	1.00	1.00	8.33	0.12	2.59
LIT-21	0.73	0.47	0.25	0.65	0.000	0.048	0.12	0.00	1.00	1.00	8.33	0.12	3.45
LIT-21	0.84	0.43	0.40	0.52	0.000	0.048	0.12	0.00	1.00	1.00	8.33	0.12	3.97
LIT-21	0.19	0.12	0.07	0.63	0.000	0.048	0.14	0.00	1.00	1.00	7.14	0.14	0.69
LIT-21	0.39	0.25	0.14	0.63	0.000	0.048	0.14	0.00	1.00	1.00	7.14	0.14	1.39
LIT-21	0.57	0.36	0.21	0.63	0.000	0.048	0.14	0.00	1.00	1.00	7.14	0.14	2.05
LIT-21	0.71	0.44	0.27	0.62	0.000	0.048	0.14	0.00	1.00	1.00	7.14	0.14	2.55
LIT-21	0.93	0.50	0.43	0.54	0.000	0.048	0.14	0.00	1.00	1.00	7.14	0.14	3.35
LIT-21	1.01	0.45	0.56	0.44	0.000	0.048	0.14	0.00	1.00	1.00	7.14	0.14	3.65
LIT-21	1.11	0.34	0.77	0.31	0.000	0.048	0.14	0.00	1.00	1.00	7.14	0.14	4.01
LIT-21	0.24	0.14	0.10	0.57	0.000	0.048	0.16	0.00	1.00	1.00	6.25	0.16	0.69
LIT-21	0.51	0.29	0.22	0.57	0.000	0.048	0.16	0.00	1.00	1.00	6.25	0.16	1.45

Continued on next page

Table 5: Literature-Derived Performance Data for Drop-Type Inlets — Continued

ID-CODE	Q_A	Q_I	Q_O	Q_R	S_0	S_x	d_a	h_b	L_I	W_I	L_R	W_R	Fr
LIT-21	0.87	0.48	0.40	0.55	0.000	0.048	0.16	0.00	1.00	1.00	6.25	0.16	2.50
LIT-21	0.97	0.51	0.46	0.53	0.000	0.048	0.16	0.00	1.00	1.00	6.25	0.16	2.77
LIT-21	1.22	0.44	0.78	0.36	0.000	0.048	0.16	0.00	1.00	1.00	6.25	0.16	3.48
LIT-21	0.30	0.15	0.14	0.52	0.000	0.048	0.18	0.00	1.00	1.00	5.56	0.18	0.70
LIT-21	0.64	0.33	0.31	0.52	0.000	0.048	0.18	0.00	1.00	1.00	5.56	0.18	1.49
LIT-21	0.86	0.43	0.43	0.50	0.000	0.048	0.18	0.00	1.00	1.00	5.56	0.18	2.01
LIT-21	1.07	0.50	0.57	0.47	0.000	0.048	0.18	0.00	1.00	1.00	5.56	0.18	2.50
LIT-21	1.25	0.47	0.78	0.37	0.000	0.048	0.18	0.00	1.00	1.00	5.56	0.18	2.92
LIT-21	0.36	0.17	0.18	0.48	0.000	0.048	0.20	0.00	1.00	1.00	5.00	0.20	0.70
LIT-21	0.77	0.36	0.41	0.47	0.000	0.048	0.20	0.00	1.00	1.00	5.00	0.20	1.52
LIT-21	1.19	0.52	0.67	0.44	0.000	0.048	0.20	0.00	1.00	1.00	5.00	0.20	2.34
LIT-21	1.35	0.50	0.85	0.37	0.000	0.048	0.20	0.00	1.00	1.00	5.00	0.20	2.65
LIT-21	1.53	0.41	1.12	0.26	0.000	0.048	0.20	0.00	1.00	1.00	5.00	0.20	3.00
LIT-21	0.51	0.20	0.31	0.39	0.000	0.048	0.25	0.00	1.00	1.00	4.00	0.25	0.70
LIT-21	0.92	0.35	0.57	0.38	0.000	0.048	0.25	0.00	1.00	1.00	4.00	0.25	1.25
LIT-21	1.17	0.44	0.73	0.38	0.000	0.048	0.25	0.00	1.00	1.00	4.00	0.25	1.59
LIT-21	1.62	0.49	1.13	0.30	0.000	0.048	0.25	0.00	1.00	1.00	4.00	0.25	2.20
LIT-21	1.75	0.42	1.33	0.24	0.000	0.048	0.25	0.00	1.00	1.00	4.00	0.25	2.38
LIT-21	0.69	0.23	0.47	0.33	0.000	0.048	0.30	0.00	1.00	1.00	3.33	0.30	0.70
LIT-21	1.21	0.39	0.82	0.32	0.000	0.048	0.30	0.00	1.00	1.00	3.33	0.30	1.23
LIT-21	1.68	0.49	1.18	0.29	0.000	0.048	0.30	0.00	1.00	1.00	3.33	0.30	1.70
LIT-21	1.87	0.49	1.37	0.27	0.000	0.048	0.30	0.00	1.00	1.00	3.33	0.30	1.89
LIT-21	2.02	0.46	1.56	0.23	0.000	0.048	0.30	0.00	1.00	1.00	3.33	0.30	2.05
LIT-22	0.09	0.05	0.05	0.50	0.000	0.020	0.08	0.00	1.00	1.00	12.50	0.08	0.71
LIT-22	0.15	0.07	0.07	0.50	0.000	0.020	0.08	0.00	1.00	1.00	12.50	0.08	1.16
LIT-22	0.20	0.10	0.10	0.49	0.000	0.020	0.08	0.00	1.00	1.00	12.50	0.08	1.56
LIT-22	0.26	0.13	0.13	0.50	0.000	0.020	0.08	0.00	1.00	1.00	12.50	0.08	2.01
LIT-22	0.41	0.20	0.21	0.49	0.000	0.020	0.08	0.00	1.00	1.00	12.50	0.08	3.23
LIT-22	0.57	0.27	0.30	0.48	0.000	0.020	0.08	0.00	1.00	1.00	12.50	0.08	4.49
LIT-22	0.65	0.31	0.35	0.47	0.000	0.020	0.08	0.00	1.00	1.00	12.50	0.08	5.09
LIT-22	0.78	0.32	0.46	0.41	0.000	0.020	0.08	0.00	1.00	1.00	12.50	0.08	6.06
LIT-22	0.13	0.05	0.08	0.41	0.000	0.020	0.10	0.00	1.00	1.00	10.00	0.10	0.70
LIT-22	0.21	0.08	0.12	0.40	0.000	0.020	0.10	0.00	1.00	1.00	10.00	0.10	1.12
LIT-22	0.28	0.11	0.17	0.41	0.000	0.020	0.10	0.00	1.00	1.00	10.00	0.10	1.52
LIT-22	0.37	0.15	0.22	0.41	0.000	0.020	0.10	0.00	1.00	1.00	10.00	0.10	2.03
LIT-22	0.62	0.25	0.37	0.40	0.000	0.020	0.10	0.00	1.00	1.00	10.00	0.10	3.34
LIT-22	0.79	0.31	0.48	0.39	0.000	0.020	0.10	0.00	1.00	1.00	10.00	0.10	4.26
LIT-22	0.93	0.31	0.62	0.34	0.000	0.020	0.10	0.00	1.00	1.00	10.00	0.10	5.05
LIT-22	0.23	0.07	0.16	0.30	0.000	0.020	0.14	0.00	1.00	1.00	7.14	0.14	0.73

Continued on next page

Table 5: Literature-Derived Performance Data for Drop-Type Inlets — Continued

ID-CODE	Q_A	Q_I	Q_O	Q_R	S_0	S_x	d_a	h_b	L_I	W_I	L_R	W_R	Fr
LIT-22	0.37	0.11	0.26	0.30	0.000	0.020	0.14	0.00	1.00	1.00	7.14	0.14	1.17
LIT-22	0.65	0.19	0.46	0.29	0.000	0.020	0.14	0.00	1.00	1.00	7.14	0.14	2.04
LIT-22	0.80	0.23	0.56	0.29	0.000	0.020	0.14	0.00	1.00	1.00	7.14	0.14	2.51
LIT-22	0.98	0.29	0.70	0.29	0.000	0.020	0.14	0.00	1.00	1.00	7.14	0.14	3.09
LIT-22	1.29	0.29	1.00	0.23	0.000	0.020	0.14	0.00	1.00	1.00	7.14	0.14	4.05
LIT-22	0.40	0.09	0.32	0.22	0.000	0.020	0.20	0.00	1.00	1.00	5.00	0.20	0.72
LIT-22	0.63	0.14	0.49	0.22	0.000	0.020	0.20	0.00	1.00	1.00	5.00	0.20	1.12
LIT-22	0.82	0.18	0.64	0.22	0.000	0.020	0.20	0.00	1.00	1.00	5.00	0.20	1.47
LIT-22	1.12	0.24	0.89	0.21	0.000	0.020	0.20	0.00	1.00	1.00	5.00	0.20	2.02
LIT-22	1.40	0.27	1.13	0.20	0.000	0.020	0.20	0.00	1.00	1.00	5.00	0.20	2.51
LIT-22	1.70	0.28	1.42	0.17	0.000	0.020	0.20	0.00	1.00	1.00	5.00	0.20	3.04
LIT-22	0.55	0.10	0.45	0.18	0.000	0.020	0.25	0.00	1.00	1.00	4.00	0.25	0.69
LIT-22	0.84	0.15	0.69	0.18	0.000	0.020	0.25	0.00	1.00	1.00	4.00	0.25	1.07
LIT-22	1.10	0.19	0.91	0.17	0.000	0.020	0.25	0.00	1.00	1.00	4.00	0.25	1.39
LIT-22	1.45	0.24	1.21	0.17	0.000	0.020	0.25	0.00	1.00	1.00	4.00	0.25	1.84
LIT-22	1.79	0.26	1.53	0.15	0.000	0.020	0.25	0.00	1.00	1.00	4.00	0.25	2.27
LIT-22	0.76	0.11	0.65	0.14	0.000	0.020	0.30	0.00	1.00	1.00	3.33	0.30	0.72
LIT-22	1.21	0.17	1.04	0.14	0.000	0.020	0.30	0.00	1.00	1.00	3.33	0.30	1.16
LIT-22	1.57	0.22	1.35	0.14	0.000	0.020	0.30	0.00	1.00	1.00	3.33	0.30	1.50
LIT-22	1.83	0.25	1.58	0.14	0.000	0.020	0.30	0.00	1.00	1.00	3.33	0.30	1.75
LIT-22	2.13	0.26	1.87	0.12	0.000	0.020	0.30	0.00	1.00	1.00	3.33	0.30	2.03
LIT-22	0.07	0.06	0.01	0.93	0.000	0.048	0.08	0.00	1.00	1.00	12.50	0.08	0.71
LIT-22	0.12	0.11	0.01	0.92	0.000	0.048	0.08	0.00	1.00	1.00	12.50	0.08	1.25
LIT-22	0.17	0.16	0.01	0.92	0.000	0.048	0.08	0.00	1.00	1.00	12.50	0.08	1.78
LIT-22	0.22	0.20	0.02	0.91	0.000	0.048	0.08	0.00	1.00	1.00	12.50	0.08	2.21
LIT-22	0.23	0.21	0.02	0.91	0.000	0.048	0.08	0.00	1.00	1.00	12.50	0.08	2.38
LIT-22	0.29	0.26	0.03	0.91	0.000	0.048	0.08	0.00	1.00	1.00	12.50	0.08	2.97
LIT-22	0.39	0.35	0.04	0.90	0.000	0.048	0.08	0.00	1.00	1.00	12.50	0.08	4.00
LIT-22	0.44	0.39	0.05	0.89	0.000	0.048	0.08	0.00	1.00	1.00	12.50	0.08	4.49
LIT-22	0.48	0.43	0.05	0.89	0.000	0.048	0.08	0.00	1.00	1.00	12.50	0.08	4.97
LIT-22	0.54	0.47	0.06	0.88	0.000	0.048	0.08	0.00	1.00	1.00	12.50	0.08	5.50
LIT-22	0.59	0.51	0.08	0.86	0.000	0.048	0.08	0.00	1.00	1.00	12.50	0.08	6.04
LIT-22	0.11	0.09	0.02	0.80	0.000	0.048	0.10	0.00	1.00	1.00	10.00	0.10	0.72
LIT-22	0.19	0.15	0.04	0.81	0.000	0.048	0.10	0.00	1.00	1.00	10.00	0.10	1.25
LIT-22	0.34	0.27	0.07	0.80	0.000	0.048	0.10	0.00	1.00	1.00	10.00	0.10	2.24
LIT-22	0.44	0.34	0.09	0.79	0.000	0.048	0.10	0.00	1.00	1.00	10.00	0.10	2.89
LIT-22	0.62	0.48	0.13	0.78	0.000	0.048	0.10	0.00	1.00	1.00	10.00	0.10	4.10
LIT-22	0.73	0.53	0.19	0.73	0.000	0.048	0.10	0.00	1.00	1.00	10.00	0.10	4.84
LIT-22	0.79	0.53	0.26	0.67	0.000	0.048	0.10	0.00	1.00	1.00	10.00	0.10	5.22

Continued on next page

Table 5: Literature-Derived Performance Data for Drop-Type Inlets — Continued

ID-CODE	Q_A	Q_I	Q_O	Q_R	S_0	S_x	d_a	h_b	L_I	W_I	L_R	W_R	Fr
LIT-22	0.15	0.11	0.04	0.72	0.000	0.048	0.12	0.00	1.00	1.00	8.33	0.12	0.73
LIT-22	0.29	0.21	0.08	0.72	0.000	0.048	0.12	0.00	1.00	1.00	8.33	0.12	1.40
LIT-22	0.42	0.30	0.12	0.71	0.000	0.048	0.12	0.00	1.00	1.00	8.33	0.12	2.01
LIT-22	0.65	0.45	0.19	0.70	0.000	0.048	0.12	0.00	1.00	1.00	8.33	0.12	3.06
LIT-22	0.84	0.56	0.28	0.66	0.000	0.048	0.12	0.00	1.00	1.00	8.33	0.12	4.00
LIT-22	1.05	0.55	0.50	0.52	0.000	0.048	0.12	0.00	1.00	1.00	8.33	0.12	4.99
LIT-22	0.20	0.13	0.07	0.63	0.000	0.048	0.14	0.00	1.00	1.00	7.14	0.14	0.72
LIT-22	0.28	0.18	0.10	0.63	0.000	0.048	0.14	0.00	1.00	1.00	7.14	0.14	1.01
LIT-22	0.42	0.26	0.15	0.64	0.000	0.048	0.14	0.00	1.00	1.00	7.14	0.14	1.50
LIT-22	0.56	0.35	0.21	0.63	0.000	0.048	0.14	0.00	1.00	1.00	7.14	0.14	2.02
LIT-22	0.83	0.51	0.32	0.62	0.000	0.048	0.14	0.00	1.00	1.00	7.14	0.14	2.99
LIT-22	1.11	0.56	0.55	0.51	0.000	0.048	0.14	0.00	1.00	1.00	7.14	0.14	3.99
LIT-22	0.25	0.14	0.11	0.57	0.000	0.048	0.16	0.00	1.00	1.00	6.25	0.16	0.72
LIT-22	0.41	0.23	0.18	0.57	0.000	0.048	0.16	0.00	1.00	1.00	6.25	0.16	1.18
LIT-22	0.51	0.29	0.22	0.56	0.000	0.048	0.16	0.00	1.00	1.00	6.25	0.16	1.45
LIT-22	0.70	0.40	0.30	0.57	0.000	0.048	0.16	0.00	1.00	1.00	6.25	0.16	2.00
LIT-22	0.91	0.51	0.41	0.55	0.000	0.048	0.16	0.00	1.00	1.00	6.25	0.16	2.61
LIT-22	1.05	0.57	0.48	0.54	0.000	0.048	0.16	0.00	1.00	1.00	6.25	0.16	3.01
LIT-22	1.40	0.57	0.83	0.41	0.000	0.048	0.16	0.00	1.00	1.00	6.25	0.16	4.02
LIT-22	0.31	0.16	0.15	0.51	0.000	0.048	0.18	0.00	1.00	1.00	5.56	0.18	0.72
LIT-22	0.43	0.22	0.21	0.52	0.000	0.048	0.18	0.00	1.00	1.00	5.56	0.18	1.00
LIT-22	0.63	0.32	0.30	0.52	0.000	0.048	0.18	0.00	1.00	1.00	5.56	0.18	1.48
LIT-22	0.86	0.44	0.42	0.51	0.000	0.048	0.18	0.00	1.00	1.00	5.56	0.18	2.01
LIT-22	1.08	0.54	0.54	0.50	0.000	0.048	0.18	0.00	1.00	1.00	5.56	0.18	2.53
LIT-22	1.29	0.59	0.70	0.46	0.000	0.048	0.18	0.00	1.00	1.00	5.56	0.18	3.02
LIT-22	1.69	0.55	1.15	0.32	0.000	0.048	0.18	0.00	1.00	1.00	5.56	0.18	3.97
LIT-22	0.36	0.17	0.19	0.46	0.000	0.048	0.20	0.00	1.00	1.00	5.00	0.20	0.71
LIT-22	0.54	0.25	0.29	0.47	0.000	0.048	0.20	0.00	1.00	1.00	5.00	0.20	1.07
LIT-22	0.76	0.36	0.41	0.47	0.000	0.048	0.20	0.00	1.00	1.00	5.00	0.20	1.50
LIT-22	1.01	0.47	0.54	0.46	0.000	0.048	0.20	0.00	1.00	1.00	5.00	0.20	1.98
LIT-22	1.29	0.57	0.71	0.45	0.000	0.048	0.20	0.00	1.00	1.00	5.00	0.20	2.53
LIT-22	1.54	0.59	0.96	0.38	0.000	0.048	0.20	0.00	1.00	1.00	5.00	0.20	3.03
LIT-22	1.78	0.56	1.22	0.31	0.000	0.048	0.20	0.00	1.00	1.00	5.00	0.20	3.49
LIT-22	0.51	0.20	0.31	0.38	0.000	0.048	0.25	0.00	1.00	1.00	4.00	0.25	0.69
LIT-22	0.82	0.31	0.50	0.38	0.000	0.048	0.25	0.00	1.00	1.00	4.00	0.25	1.11
LIT-22	1.14	0.44	0.70	0.39	0.000	0.048	0.25	0.00	1.00	1.00	4.00	0.25	1.56
LIT-22	1.53	0.56	0.96	0.37	0.000	0.048	0.25	0.00	1.00	1.00	4.00	0.25	2.08
LIT-22	1.91	0.57	1.34	0.30	0.000	0.048	0.25	0.00	1.00	1.00	4.00	0.25	2.59
LIT-22	0.70	0.23	0.46	0.34	0.000	0.048	0.30	0.00	1.00	1.00	3.33	0.30	0.71

Continued on next page

Table 5: Literature-Derived Performance Data for Drop-Type Inlets — Continued

ID-CODE	Q_A	Q_I	Q_O	Q_R	S_0	S_x	d_a	h_b	L_I	W_I	L_R	W_R	Fr
LIT-22	1.12	0.37	0.75	0.33	0.000	0.048	0.30	0.00	1.00	1.00	3.33	0.30	1.14
LIT-22	1.49	0.49	1.00	0.33	0.000	0.048	0.30	0.00	1.00	1.00	3.33	0.30	1.51
LIT-22	1.77	0.55	1.21	0.31	0.000	0.048	0.30	0.00	1.00	1.00	3.33	0.30	1.79
LIT-22	2.06	0.54	1.51	0.26	0.000	0.048	0.30	0.00	1.00	1.00	3.33	0.30	2.09
LIT-23	0.04	0.04	0.00	0.99	0.000	0.048	0.06	0.00	1.00	1.00	16.67	0.06	0.69
LIT-23	0.05	0.05	0.00	0.99	0.000	0.048	0.06	0.00	1.00	1.00	16.67	0.06	0.97
LIT-23	0.10	0.10	0.00	0.99	0.000	0.048	0.06	0.00	1.00	1.00	16.67	0.06	1.95
LIT-23	0.15	0.15	0.00	1.00	0.000	0.048	0.06	0.00	1.00	1.00	16.67	0.06	2.98
LIT-23	0.21	0.19	0.01	0.94	0.000	0.048	0.06	0.00	1.00	1.00	16.67	0.06	3.98
LIT-23	0.28	0.23	0.05	0.81	0.000	0.048	0.06	0.00	1.00	1.00	16.67	0.06	5.48
LIT-23	0.32	0.24	0.07	0.77	0.000	0.048	0.06	0.00	1.00	1.00	16.67	0.06	6.07
LIT-23	0.37	0.26	0.10	0.72	0.000	0.048	0.06	0.00	1.00	1.00	16.67	0.06	7.11
LIT-23	0.05	0.05	0.00	0.96	0.000	0.048	0.07	0.00	1.00	1.00	14.29	0.07	0.71
LIT-23	0.07	0.07	0.00	0.96	0.000	0.048	0.07	0.00	1.00	1.00	14.29	0.07	0.99
LIT-23	0.10	0.10	0.00	0.96	0.000	0.048	0.07	0.00	1.00	1.00	14.29	0.07	1.39
LIT-23	0.16	0.16	0.01	0.96	0.000	0.048	0.07	0.00	1.00	1.00	14.29	0.07	2.23
LIT-23	0.22	0.20	0.02	0.93	0.000	0.048	0.07	0.00	1.00	1.00	14.29	0.07	2.98
LIT-23	0.29	0.24	0.06	0.80	0.000	0.048	0.07	0.00	1.00	1.00	14.29	0.07	3.98
LIT-23	0.37	0.26	0.11	0.70	0.000	0.048	0.07	0.00	1.00	1.00	14.29	0.07	5.03
LIT-23	0.43	0.28	0.15	0.65	0.000	0.048	0.07	0.00	1.00	1.00	14.29	0.07	5.89
LIT-23	0.47	0.30	0.18	0.63	0.000	0.048	0.07	0.00	1.00	1.00	14.29	0.07	6.44
LIT-23	0.07	0.06	0.01	0.90	0.000	0.048	0.08	0.00	1.00	1.00	12.50	0.08	0.69
LIT-23	0.13	0.11	0.01	0.89	0.000	0.048	0.08	0.00	1.00	1.00	12.50	0.08	1.30
LIT-23	0.19	0.17	0.02	0.88	0.000	0.048	0.08	0.00	1.00	1.00	12.50	0.08	1.98
LIT-23	0.29	0.23	0.05	0.81	0.000	0.048	0.08	0.00	1.00	1.00	12.50	0.08	2.93
LIT-23	0.40	0.28	0.12	0.70	0.000	0.048	0.08	0.00	1.00	1.00	12.50	0.08	4.07
LIT-23	0.48	0.30	0.18	0.62	0.000	0.048	0.08	0.00	1.00	1.00	12.50	0.08	4.90
LIT-23	0.58	0.34	0.25	0.58	0.000	0.048	0.08	0.00	1.00	1.00	12.50	0.08	6.00
LIT-23	0.09	0.07	0.02	0.80	0.000	0.048	0.09	0.00	1.00	1.00	11.11	0.09	0.69
LIT-23	0.15	0.12	0.03	0.80	0.000	0.048	0.09	0.00	1.00	1.00	11.11	0.09	1.19
LIT-23	0.25	0.20	0.05	0.80	0.000	0.048	0.09	0.00	1.00	1.00	11.11	0.09	2.02
LIT-23	0.37	0.26	0.11	0.71	0.000	0.048	0.09	0.00	1.00	1.00	11.11	0.09	2.98
LIT-23	0.50	0.30	0.19	0.62	0.000	0.048	0.09	0.00	1.00	1.00	11.11	0.09	4.02
LIT-23	0.61	0.33	0.28	0.54	0.000	0.048	0.09	0.00	1.00	1.00	11.11	0.09	4.94
LIT-23	0.73	0.37	0.36	0.51	0.000	0.048	0.09	0.00	1.00	1.00	11.11	0.09	5.93
LIT-23	0.11	0.08	0.03	0.74	0.000	0.048	0.10	0.00	1.00	1.00	10.00	0.10	0.71
LIT-23	0.17	0.12	0.04	0.74	0.000	0.048	0.10	0.00	1.00	1.00	10.00	0.10	1.12
LIT-23	0.29	0.21	0.08	0.74	0.000	0.048	0.10	0.00	1.00	1.00	10.00	0.10	1.93
LIT-23	0.46	0.30	0.16	0.65	0.000	0.048	0.10	0.00	1.00	1.00	10.00	0.10	3.05

Continued on next page

Table 5: Literature-Derived Performance Data for Drop-Type Inlets — Continued

ID-CODE	Q_A	Q_I	Q_O	Q_R	S_0	S_x	d_a	h_b	L_I	W_I	L_R	W_R	Fr
LIT-23	0.59	0.34	0.26	0.57	0.000	0.048	0.10	0.00	1.00	1.00	10.00	0.10	3.92
LIT-23	0.75	0.36	0.38	0.49	0.000	0.048	0.10	0.00	1.00	1.00	10.00	0.10	4.97
LIT-23	0.22	0.12	0.10	0.56	0.000	0.048	0.15	0.00	1.00	1.00	6.67	0.15	0.70
LIT-23	0.39	0.21	0.17	0.55	0.000	0.048	0.15	0.00	1.00	1.00	6.67	0.15	1.24
LIT-23	0.46	0.25	0.21	0.55	0.000	0.048	0.15	0.00	1.00	1.00	6.67	0.15	1.46
LIT-23	0.64	0.32	0.32	0.50	0.000	0.048	0.15	0.00	1.00	1.00	6.67	0.15	2.06
LIT-23	0.89	0.39	0.50	0.44	0.000	0.048	0.15	0.00	1.00	1.00	6.67	0.15	2.86
LIT-23	1.15	0.41	0.73	0.36	0.000	0.048	0.15	0.00	1.00	1.00	6.67	0.15	3.67
LIT-23	1.40	0.44	0.96	0.32	0.000	0.048	0.15	0.00	1.00	1.00	6.67	0.15	4.47
LIT-23	0.37	0.15	0.22	0.40	0.000	0.048	0.20	0.00	1.00	1.00	5.00	0.20	0.72
LIT-23	0.53	0.21	0.32	0.40	0.000	0.048	0.20	0.00	1.00	1.00	5.00	0.20	1.03
LIT-23	1.00	0.32	0.68	0.32	0.000	0.048	0.20	0.00	1.00	1.00	5.00	0.20	1.97
LIT-24	1.52	0.34	1.18	0.22	0.000	0.048	0.20	0.00	1.00	1.00	5.00	0.20	2.99
LIT-24	0.05	0.03	0.02	0.58	0.000	0.020	0.06	0.00	1.00	1.00	16.67	0.06	0.68
LIT-24	0.13	0.08	0.06	0.57	0.000	0.020	0.06	0.00	1.00	1.00	16.67	0.06	1.67
LIT-24	0.16	0.09	0.07	0.57	0.000	0.020	0.06	0.00	1.00	1.00	16.67	0.06	2.00
LIT-24	0.24	0.13	0.10	0.56	0.000	0.020	0.06	0.00	1.00	1.00	16.67	0.06	3.03
LIT-24	0.31	0.17	0.14	0.55	0.000	0.020	0.06	0.00	1.00	1.00	16.67	0.06	4.01
LIT-24	0.40	0.22	0.18	0.54	0.000	0.020	0.06	0.00	1.00	1.00	16.67	0.06	5.07
LIT-24	0.51	0.23	0.29	0.44	0.000	0.020	0.06	0.00	1.00	1.00	16.67	0.06	6.53
LIT-24	0.07	0.04	0.04	0.51	0.000	0.020	0.07	0.00	1.00	1.00	14.29	0.07	0.70
LIT-24	0.15	0.08	0.08	0.50	0.000	0.020	0.07	0.00	1.00	1.00	14.29	0.07	1.49
LIT-24	0.22	0.11	0.11	0.49	0.000	0.020	0.07	0.00	1.00	1.00	14.29	0.07	2.11
LIT-24	0.31	0.15	0.16	0.49	0.000	0.020	0.07	0.00	1.00	1.00	14.29	0.07	3.04
LIT-24	0.40	0.19	0.21	0.48	0.000	0.020	0.07	0.00	1.00	1.00	14.29	0.07	3.92
LIT-24	0.51	0.23	0.28	0.46	0.000	0.020	0.07	0.00	1.00	1.00	14.29	0.07	4.99
LIT-24	0.62	0.22	0.40	0.35	0.000	0.020	0.07	0.00	1.00	1.00	14.29	0.07	6.09
LIT-24	0.09	0.04	0.05	0.46	0.000	0.020	0.08	0.00	1.00	1.00	12.50	0.08	0.67
LIT-24	0.19	0.09	0.11	0.45	0.000	0.020	0.08	0.00	1.00	1.00	12.50	0.08	1.52
LIT-24	0.25	0.11	0.14	0.44	0.000	0.020	0.08	0.00	1.00	1.00	12.50	0.08	1.99
LIT-24	0.39	0.17	0.22	0.44	0.000	0.020	0.08	0.00	1.00	1.00	12.50	0.08	3.02
LIT-24	0.51	0.22	0.29	0.43	0.000	0.020	0.08	0.00	1.00	1.00	12.50	0.08	4.02
LIT-24	0.64	0.24	0.40	0.37	0.000	0.020	0.08	0.00	1.00	1.00	12.50	0.08	5.01
LIT-24	0.69	0.23	0.47	0.33	0.000	0.020	0.08	0.00	1.00	1.00	12.50	0.08	5.42
LIT-24	0.11	0.04	0.06	0.41	0.000	0.020	0.09	0.00	1.00	1.00	11.11	0.09	0.69
LIT-24	0.22	0.09	0.13	0.40	0.000	0.020	0.09	0.00	1.00	1.00	11.11	0.09	1.45
LIT-24	0.31	0.13	0.19	0.40	0.000	0.020	0.09	0.00	1.00	1.00	11.11	0.09	2.02
LIT-24	0.47	0.19	0.28	0.40	0.000	0.020	0.09	0.00	1.00	1.00	11.11	0.09	3.04
LIT-24	0.63	0.24	0.39	0.38	0.000	0.020	0.09	0.00	1.00	1.00	11.11	0.09	4.02

Continued on next page

Table 5: Literature-Derived Performance Data for Drop-Type Inlets — Continued

ID-CODE	Q_A	Q_I	Q_O	Q_R	S_0	S_x	d_a	h_b	L_I	W_I	L_R	W_R	Fr
LIT-24	0.80	0.23	0.57	0.29	0.000	0.020	0.09	0.00	1.00	1.00	11.11	0.09	5.13
LIT-24	0.13	0.05	0.08	0.37	0.000	0.020	0.10	0.00	1.00	1.00	10.00	0.10	0.71
LIT-24	0.27	0.10	0.17	0.37	0.000	0.020	0.10	0.00	1.00	1.00	10.00	0.10	1.48
LIT-24	0.38	0.14	0.24	0.37	0.000	0.020	0.10	0.00	1.00	1.00	10.00	0.10	2.04
LIT-24	0.54	0.20	0.35	0.36	0.000	0.020	0.10	0.00	1.00	1.00	10.00	0.10	2.94
LIT-24	0.74	0.24	0.50	0.33	0.000	0.020	0.10	0.00	1.00	1.00	10.00	0.10	4.01
LIT-24	0.89	0.24	0.65	0.27	0.000	0.020	0.10	0.00	1.00	1.00	10.00	0.10	4.82
LIT-24	0.15	0.05	0.10	0.34	0.000	0.020	0.11	0.00	1.00	1.00	9.09	0.11	0.69
LIT-24	0.33	0.11	0.22	0.34	0.000	0.020	0.11	0.00	1.00	1.00	9.09	0.11	1.55
LIT-24	0.42	0.14	0.28	0.34	0.000	0.020	0.11	0.00	1.00	1.00	9.09	0.11	1.94
LIT-24	0.65	0.21	0.44	0.33	0.000	0.020	0.11	0.00	1.00	1.00	9.09	0.11	3.00
LIT-24	0.86	0.24	0.62	0.28	0.000	0.020	0.11	0.00	1.00	1.00	9.09	0.11	3.98
LIT-24	0.98	0.23	0.75	0.23	0.000	0.020	0.11	0.00	1.00	1.00	9.09	0.11	4.54
LIT-24	0.18	0.06	0.12	0.32	0.000	0.020	0.12	0.00	1.00	1.00	8.33	0.12	0.71
LIT-24	0.38	0.12	0.26	0.31	0.000	0.020	0.12	0.00	1.00	1.00	8.33	0.12	1.52
LIT-24	0.75	0.22	0.53	0.30	0.000	0.020	0.12	0.00	1.00	1.00	8.33	0.12	3.03
LIT-24	0.98	0.23	0.75	0.24	0.000	0.020	0.12	0.00	1.00	1.00	8.33	0.12	3.95
LIT-24	0.20	0.06	0.14	0.29	0.000	0.020	0.13	0.00	1.00	1.00	7.69	0.13	0.71
LIT-24	0.41	0.12	0.30	0.29	0.000	0.020	0.13	0.00	1.00	1.00	7.69	0.13	1.47
LIT-24	0.57	0.16	0.41	0.29	0.000	0.020	0.13	0.00	1.00	1.00	7.69	0.13	2.01
LIT-24	1.11	0.21	0.90	0.19	0.000	0.020	0.13	0.00	1.00	1.00	7.69	0.13	3.92
LIT-24	0.22	0.06	0.16	0.27	0.000	0.020	0.14	0.00	1.00	1.00	7.14	0.14	0.68
LIT-24	0.45	0.12	0.33	0.27	0.000	0.020	0.14	0.00	1.00	1.00	7.14	0.14	1.41
LIT-24	0.65	0.17	0.48	0.26	0.000	0.020	0.14	0.00	1.00	1.00	7.14	0.14	2.04
LIT-24	0.80	0.21	0.59	0.26	0.000	0.020	0.14	0.00	1.00	1.00	7.14	0.14	2.52
LIT-24	0.96	0.23	0.74	0.24	0.000	0.020	0.14	0.00	1.00	1.00	7.14	0.14	3.03
LIT-24	1.13	0.22	0.91	0.20	0.000	0.020	0.14	0.00	1.00	1.00	7.14	0.14	3.55
LIT-24	0.27	0.06	0.20	0.24	0.000	0.020	0.16	0.00	1.00	1.00	6.25	0.16	0.68
LIT-24	0.56	0.13	0.43	0.24	0.000	0.020	0.16	0.00	1.00	1.00	6.25	0.16	1.44
LIT-24	0.80	0.19	0.61	0.23	0.000	0.020	0.16	0.00	1.00	1.00	6.25	0.16	2.03
LIT-24	1.19	0.22	0.98	0.18	0.000	0.020	0.16	0.00	1.00	1.00	6.25	0.16	3.04
LIT-24	1.37	0.19	1.18	0.14	0.000	0.020	0.16	0.00	1.00	1.00	6.25	0.16	3.48
LIT-24	0.32	0.07	0.26	0.21	0.000	0.020	0.18	0.00	1.00	1.00	5.56	0.18	0.69
LIT-24	0.72	0.14	0.57	0.20	0.000	0.020	0.18	0.00	1.00	1.00	5.56	0.18	1.51
LIT-24	0.94	0.19	0.75	0.20	0.000	0.020	0.18	0.00	1.00	1.00	5.56	0.18	1.99
LIT-24	1.19	0.21	0.98	0.18	0.000	0.020	0.18	0.00	1.00	1.00	5.56	0.18	2.52
LIT-24	1.43	0.20	1.23	0.14	0.000	0.020	0.18	0.00	1.00	1.00	5.56	0.18	3.02
LIT-24	0.37	0.07	0.31	0.18	0.000	0.020	0.20	0.00	1.00	1.00	5.00	0.20	0.67
LIT-24	0.80	0.15	0.66	0.18	0.000	0.020	0.20	0.00	1.00	1.00	5.00	0.20	1.44

Continued on next page

Table 5: Literature-Derived Performance Data for Drop-Type Inlets — Continued

ID-CODE	Q_A	Q_I	Q_O	Q_R	S_0	S_x	d_a	h_b	L_I	W_I	L_R	W_R	Fr
LIT-24	1.11	0.19	0.91	0.18	0.000	0.020	0.20	0.00	1.00	1.00	5.00	0.20	1.99
LIT-24	1.38	0.20	1.18	0.15	0.000	0.020	0.20	0.00	1.00	1.00	5.00	0.20	2.48
LIT-24	1.67	0.18	1.49	0.11	0.000	0.020	0.20	0.00	1.00	1.00	5.00	0.20	3.00
LIT-24	0.55	0.08	0.47	0.14	0.000	0.020	0.25	0.00	1.00	1.00	4.00	0.25	0.70
LIT-24	1.08	0.16	0.92	0.15	0.000	0.020	0.25	0.00	1.00	1.00	4.00	0.25	1.37
LIT-24	1.45	0.18	1.27	0.13	0.000	0.020	0.25	0.00	1.00	1.00	4.00	0.25	1.84
LIT-24	1.84	0.18	1.66	0.10	0.000	0.020	0.25	0.00	1.00	1.00	4.00	0.25	2.33
LIT-24	0.04	0.04	0.00	0.95	0.000	0.048	0.06	0.00	1.00	1.00	16.67	0.06	0.71
LIT-24	0.09	0.08	0.00	0.95	0.000	0.048	0.06	0.00	1.00	1.00	16.67	0.06	1.69
LIT-24	0.15	0.14	0.01	0.95	0.000	0.048	0.06	0.00	1.00	1.00	16.67	0.06	2.83
LIT-24	0.21	0.20	0.01	0.94	0.000	0.048	0.06	0.00	1.00	1.00	16.67	0.06	4.14
LIT-24	0.25	0.24	0.02	0.92	0.000	0.048	0.06	0.00	1.00	1.00	16.67	0.06	4.91
LIT-24	0.31	0.28	0.03	0.90	0.000	0.048	0.06	0.00	1.00	1.00	16.67	0.06	5.98
LIT-24	0.36	0.29	0.07	0.81	0.000	0.048	0.06	0.00	1.00	1.00	16.67	0.06	6.87
LIT-24	0.40	0.29	0.11	0.73	0.000	0.048	0.06	0.00	1.00	1.00	16.67	0.06	7.76
LIT-24	0.05	0.05	0.00	0.93	0.000	0.048	0.07	0.00	1.00	1.00	14.29	0.07	0.71
LIT-24	0.12	0.11	0.01	0.93	0.000	0.048	0.07	0.00	1.00	1.00	14.29	0.07	1.59
LIT-24	0.16	0.15	0.01	0.92	0.000	0.048	0.07	0.00	1.00	1.00	14.29	0.07	2.14
LIT-24	0.23	0.20	0.02	0.91	0.000	0.048	0.07	0.00	1.00	1.00	14.29	0.07	3.07
LIT-24	0.29	0.26	0.03	0.89	0.000	0.048	0.07	0.00	1.00	1.00	14.29	0.07	3.99
LIT-24	0.36	0.31	0.05	0.87	0.000	0.048	0.07	0.00	1.00	1.00	14.29	0.07	4.91
LIT-24	0.43	0.34	0.09	0.78	0.000	0.048	0.07	0.00	1.00	1.00	14.29	0.07	5.84
LIT-24	0.48	0.34	0.15	0.70	0.000	0.048	0.07	0.00	1.00	1.00	14.29	0.07	6.59
LIT-24	0.07	0.06	0.01	0.88	0.000	0.048	0.08	0.00	1.00	1.00	12.50	0.08	0.71
LIT-24	0.15	0.13	0.02	0.87	0.000	0.048	0.08	0.00	1.00	1.00	12.50	0.08	1.50
LIT-24	0.20	0.18	0.03	0.87	0.000	0.048	0.08	0.00	1.00	1.00	12.50	0.08	2.09
LIT-24	0.29	0.25	0.04	0.85	0.000	0.048	0.08	0.00	1.00	1.00	12.50	0.08	2.98
LIT-24	0.38	0.32	0.07	0.83	0.000	0.048	0.08	0.00	1.00	1.00	12.50	0.08	3.93
LIT-24	0.49	0.37	0.12	0.75	0.000	0.048	0.08	0.00	1.00	1.00	12.50	0.08	5.04
LIT-24	0.60	0.36	0.24	0.60	0.000	0.048	0.08	0.00	1.00	1.00	12.50	0.08	6.14
LIT-24	0.09	0.07	0.02	0.81	0.000	0.048	0.09	0.00	1.00	1.00	11.11	0.09	0.69
LIT-24	0.20	0.16	0.04	0.81	0.000	0.048	0.09	0.00	1.00	1.00	11.11	0.09	1.61
LIT-24	0.25	0.20	0.05	0.80	0.000	0.048	0.09	0.00	1.00	1.00	11.11	0.09	2.00
LIT-24	0.38	0.30	0.08	0.79	0.000	0.048	0.09	0.00	1.00	1.00	11.11	0.09	3.10
LIT-24	0.47	0.36	0.11	0.76	0.000	0.048	0.09	0.00	1.00	1.00	11.11	0.09	3.84
LIT-24	0.59	0.40	0.19	0.67	0.000	0.048	0.09	0.00	1.00	1.00	11.11	0.09	4.80
LIT-24	0.72	0.36	0.36	0.51	0.000	0.048	0.09	0.00	1.00	1.00	11.11	0.09	5.84
LIT-24	0.10	0.08	0.03	0.75	0.000	0.048	0.10	0.00	1.00	1.00	10.00	0.10	0.69
LIT-24	0.23	0.17	0.06	0.75	0.000	0.048	0.10	0.00	1.00	1.00	10.00	0.10	1.50

Continued on next page

Table 5: Literature-Derived Performance Data for Drop-Type Inlets — Continued

ID-CODE	Q_A	Q_I	Q_O	Q_R	S_0	S_x	d_a	h_b	L_I	W_I	L_R	W_R	Fr
LIT-24	0.31	0.23	0.08	0.75	0.000	0.048	0.10	0.00	1.00	1.00	10.00	0.10	2.03
LIT-24	0.44	0.33	0.12	0.73	0.000	0.048	0.10	0.00	1.00	1.00	10.00	0.10	2.95
LIT-24	0.60	0.40	0.20	0.67	0.000	0.048	0.10	0.00	1.00	1.00	10.00	0.10	4.00
LIT-24	0.76	0.38	0.38	0.50	0.000	0.048	0.10	0.00	1.00	1.00	10.00	0.10	5.05
LIT-24	0.15	0.10	0.05	0.66	0.000	0.048	0.12	0.00	1.00	1.00	8.33	0.12	0.69
LIT-24	0.32	0.21	0.11	0.66	0.000	0.048	0.12	0.00	1.00	1.00	8.33	0.12	1.49
LIT-24	0.43	0.28	0.15	0.65	0.000	0.048	0.12	0.00	1.00	1.00	8.33	0.12	2.06
LIT-24	0.65	0.41	0.24	0.63	0.000	0.048	0.12	0.00	1.00	1.00	8.33	0.12	3.10
LIT-24	0.84	0.42	0.42	0.50	0.000	0.048	0.12	0.00	1.00	1.00	8.33	0.12	3.99
LIT-24	0.20	0.12	0.08	0.59	0.000	0.048	0.14	0.00	1.00	1.00	7.14	0.14	0.72
LIT-24	0.42	0.25	0.17	0.59	0.000	0.048	0.14	0.00	1.00	1.00	7.14	0.14	1.52
LIT-24	0.55	0.32	0.23	0.58	0.000	0.048	0.14	0.00	1.00	1.00	7.14	0.14	2.00
LIT-24	0.69	0.39	0.30	0.57	0.000	0.048	0.14	0.00	1.00	1.00	7.14	0.14	2.49
LIT-24	0.85	0.45	0.40	0.53	0.000	0.048	0.14	0.00	1.00	1.00	7.14	0.14	3.05
LIT-24	1.12	0.41	0.70	0.37	0.000	0.048	0.14	0.00	1.00	1.00	7.14	0.14	4.03
LIT-24	0.26	0.14	0.13	0.52	0.000	0.048	0.16	0.00	1.00	1.00	6.25	0.16	0.75
LIT-24	0.53	0.27	0.25	0.52	0.000	0.048	0.16	0.00	1.00	1.00	6.25	0.16	1.51
LIT-24	0.69	0.36	0.34	0.51	0.000	0.048	0.16	0.00	1.00	1.00	6.25	0.16	1.98
LIT-24	0.87	0.43	0.44	0.49	0.000	0.048	0.16	0.00	1.00	1.00	6.25	0.16	2.49
LIT-24	1.05	0.44	0.61	0.42	0.000	0.048	0.16	0.00	1.00	1.00	6.25	0.16	3.00
LIT-24	0.29	0.14	0.16	0.47	0.000	0.048	0.18	0.00	1.00	1.00	5.56	0.18	0.69
LIT-24	0.65	0.30	0.35	0.46	0.000	0.048	0.18	0.00	1.00	1.00	5.56	0.18	1.52
LIT-24	0.85	0.38	0.46	0.45	0.000	0.048	0.18	0.00	1.00	1.00	5.56	0.18	1.98
LIT-24	1.07	0.43	0.63	0.41	0.000	0.048	0.18	0.00	1.00	1.00	5.56	0.18	2.50
LIT-24	1.28	0.42	0.85	0.33	0.000	0.048	0.18	0.00	1.00	1.00	5.56	0.18	2.99
LIT-24	0.36	0.15	0.21	0.43	0.000	0.048	0.20	0.00	1.00	1.00	5.00	0.20	0.70
LIT-24	0.77	0.32	0.44	0.42	0.000	0.048	0.20	0.00	1.00	1.00	5.00	0.20	1.51
LIT-24	1.02	0.41	0.61	0.40	0.000	0.048	0.20	0.00	1.00	1.00	5.00	0.20	2.01
LIT-24	1.28	0.42	0.86	0.33	0.000	0.048	0.20	0.00	1.00	1.00	5.00	0.20	2.51
LIT-24	1.53	0.40	1.13	0.26	0.000	0.048	0.20	0.00	1.00	1.00	5.00	0.20	3.00
LIT-24	0.53	0.19	0.34	0.36	0.000	0.048	0.25	0.00	1.00	1.00	4.00	0.25	0.72
LIT-24	1.15	0.37	0.78	0.32	0.000	0.048	0.25	0.00	1.00	1.00	4.00	0.25	1.56
LIT-24	1.53	0.40	1.13	0.26	0.000	0.048	0.25	0.00	1.00	1.00	4.00	0.25	2.08
LIT-24	1.89	0.34	1.55	0.18	0.000	0.048	0.25	0.00	1.00	1.00	4.00	0.25	2.57
LIT-25	2.07	1.34	0.73	0.65	0.030	0.048	0.19	0.00	2.00	1.94	10.29	0.10	2.07
LIT-25	1.77	1.23	0.54	0.69	0.030	0.048	0.18	0.00	2.00	1.94	10.91	0.09	2.05
LIT-25	1.53	1.13	0.40	0.74	0.030	0.048	0.17	0.00	2.00	1.94	11.53	0.09	2.03
LIT-25	1.26	1.02	0.24	0.81	0.030	0.048	0.16	0.00	2.00	1.94	12.40	0.08	2.01
LIT-25	1.03	0.91	0.12	0.88	0.030	0.048	0.15	0.00	2.00	1.94	13.37	0.08	1.98

Continued on next page

Table 5: Literature-Derived Performance Data for Drop-Type Inlets — Continued

ID-CODE	Q_A	Q_I	Q_O	Q_R	S_0	S_x	d_a	h_b	L_I	W_I	L_R	W_R	Fr
LIT-25	0.75	0.71	0.04	0.95	0.030	0.048	0.13	0.00	2.00	1.94	15.06	0.07	1.94
LIT-25	0.44	0.44	0.00	1.00	0.030	0.048	0.11	0.00	2.00	1.94	18.40	0.06	1.88
LIT-25	2.03	1.37	0.66	0.67	0.020	0.048	0.21	0.00	2.00	1.94	9.60	0.11	1.71
LIT-25	1.72	1.27	0.45	0.74	0.020	0.048	0.20	0.00	2.00	1.94	10.21	0.10	1.69
LIT-25	1.35	1.11	0.24	0.82	0.020	0.048	0.18	0.00	2.00	1.94	11.18	0.09	1.66
LIT-25	1.11	0.98	0.13	0.88	0.020	0.048	0.17	0.00	2.00	1.94	12.04	0.09	1.64
LIT-25	0.80	0.76	0.04	0.95	0.020	0.048	0.15	0.00	2.00	1.94	13.61	0.08	1.61
LIT-25	0.58	0.58	0.00	1.00	0.020	0.048	0.13	0.00	2.00	1.94	15.35	0.07	1.58
LIT-25	2.33	1.49	0.84	0.64	0.010	0.048	0.25	0.00	2.00	1.94	7.97	0.13	1.23
LIT-25	1.89	1.32	0.57	0.70	0.010	0.048	0.23	0.00	2.00	1.94	8.62	0.12	1.22
LIT-25	1.36	1.08	0.28	0.79	0.010	0.048	0.20	0.00	2.00	1.94	9.76	0.11	1.19
LIT-25	0.87	0.79	0.08	0.91	0.010	0.048	0.17	0.00	2.00	1.94	11.54	0.09	1.16
LIT-25	0.60	0.58	0.02	0.97	0.010	0.048	0.15	0.00	2.00	1.94	13.26	0.08	1.13
LIT-25	1.40	1.10	0.30	0.79	0.010	0.048	0.21	0.00	2.00	1.94	9.65	0.11	1.19
LIT-25	2.31	1.48	0.83	0.64	0.005	0.048	0.29	0.00	2.00	1.94	6.90	0.15	0.85
LIT-25	1.92	1.31	0.61	0.68	0.005	0.048	0.27	0.00	2.00	1.94	7.39	0.14	0.84
LIT-25	1.50	1.14	0.36	0.76	0.005	0.048	0.25	0.00	2.00	1.94	8.11	0.13	0.83
LIT-25	1.10	0.91	0.19	0.83	0.005	0.048	0.22	0.00	2.00	1.94	9.11	0.11	0.81
LIT-25	0.61	0.56	0.05	0.92	0.005	0.048	0.18	0.00	2.00	1.94	11.36	0.09	0.78
LIT-25	0.43	0.42	0.01	0.98	0.005	0.048	0.15	0.00	2.00	1.94	12.96	0.08	0.77
LIT-25	0.84	0.77	0.07	0.92	0.005	0.048	0.20	0.00	2.00	1.94	10.08	0.10	0.80
LIT-26	2.04	1.27	0.77	0.62	0.030	0.048	0.19	0.00	2.00	1.94	10.35	0.10	2.07
LIT-26	1.71	1.15	0.56	0.67	0.030	0.048	0.18	0.00	2.00	1.94	11.06	0.09	2.05
LIT-26	1.41	1.05	0.36	0.74	0.030	0.048	0.17	0.00	2.00	1.94	11.89	0.09	2.02
LIT-26	1.11	0.92	0.19	0.83	0.030	0.048	0.15	0.00	2.00	1.94	13.00	0.08	1.99
LIT-26	0.80	0.74	0.06	0.93	0.030	0.048	0.14	0.00	2.00	1.94	14.70	0.07	1.95
LIT-26	0.42	0.42	0.00	1.00	0.030	0.048	0.11	0.00	2.00	1.94	18.72	0.06	1.88
LIT-26	2.04	1.32	0.72	0.65	0.020	0.048	0.21	0.00	2.00	1.94	9.58	0.11	1.71
LIT-26	1.72	1.23	0.49	0.72	0.020	0.048	0.20	0.00	2.00	1.94	10.21	0.10	1.69
LIT-26	1.42	1.12	0.30	0.79	0.020	0.048	0.18	0.00	2.00	1.94	10.97	0.09	1.67
LIT-26	1.16	0.99	0.17	0.85	0.020	0.048	0.17	0.00	2.00	1.94	11.84	0.09	1.65
LIT-26	0.84	0.78	0.06	0.93	0.020	0.048	0.15	0.00	2.00	1.94	13.36	0.08	1.61
LIT-26	0.53	0.53	0.00	1.00	0.020	0.048	0.13	0.00	2.00	1.94	15.88	0.07	1.57
LIT-26	2.17	1.41	0.76	0.65	0.010	0.048	0.24	0.00	2.00	1.94	8.19	0.13	1.23
LIT-26	1.81	1.28	0.53	0.71	0.010	0.048	0.23	0.00	2.00	1.94	8.77	0.12	1.21
LIT-26	1.53	1.16	0.37	0.76	0.010	0.048	0.21	0.00	2.00	1.94	9.34	0.11	1.20
LIT-26	1.24	1.04	0.20	0.84	0.010	0.048	0.20	0.00	2.00	1.94	10.10	0.10	1.18
LIT-26	1.04	0.91	0.13	0.88	0.010	0.048	0.19	0.00	2.00	1.94	10.79	0.10	1.17
LIT-26	0.61	0.59	0.02	0.97	0.010	0.048	0.15	0.00	2.00	1.94	13.18	0.08	1.13

Continued on next page

Table 5: Literature-Derived Performance Data for Drop-Type Inlets — Continued

ID-CODE	Q_A	Q_I	Q_O	Q_R	S_0	S_x	d_a	h_b	L_I	W_I	L_R	W_R	Fr
LIT-26	2.27	1.47	0.80	0.65	0.005	0.048	0.29	0.00	2.00	1.94	6.94	0.15	0.85
LIT-26	1.76	1.24	0.52	0.70	0.005	0.048	0.26	0.00	2.00	1.94	7.64	0.14	0.84
LIT-26	1.43	1.13	0.30	0.79	0.005	0.048	0.24	0.00	2.00	1.94	8.26	0.13	0.82
LIT-26	1.05	0.87	0.18	0.83	0.005	0.048	0.22	0.00	2.00	1.94	9.27	0.11	0.81
LIT-26	0.62	0.57	0.05	0.92	0.005	0.048	0.18	0.00	2.00	1.94	11.29	0.09	0.78
LIT-26	0.52	0.51	0.01	0.98	0.005	0.048	0.17	0.00	2.00	1.94	12.06	0.09	0.77
LIT-27	1.96	1.40	0.56	0.71	0.030	0.048	0.19	0.00	2.00	1.94	10.51	0.10	2.07
LIT-27	1.00	0.93	0.07	0.93	0.030	0.048	0.15	0.00	2.00	1.94	13.52	0.08	1.98
LIT-27	0.56	0.56	0.00	1.00	0.030	0.048	0.12	0.00	2.00	1.94	16.80	0.06	1.91
LIT-27	1.59	1.27	0.32	0.80	0.030	0.048	0.18	0.00	2.00	1.94	11.36	0.09	2.04
LIT-27	1.27	1.13	0.14	0.89	0.030	0.048	0.16	0.00	2.00	1.94	12.36	0.08	2.01
LIT-27	2.00	1.51	0.49	0.76	0.020	0.048	0.21	0.00	2.00	1.94	9.65	0.11	1.70
LIT-27	1.60	1.36	0.24	0.85	0.020	0.048	0.19	0.00	2.00	1.94	10.49	0.10	1.68
LIT-27	1.28	1.17	0.11	0.91	0.020	0.048	0.18	0.00	2.00	1.94	11.41	0.09	1.66
LIT-27	1.02	0.97	0.05	0.95	0.020	0.048	0.16	0.00	2.00	1.94	12.42	0.08	1.63
LIT-27	0.68	0.68	0.00	1.00	0.020	0.048	0.14	0.00	2.00	1.94	14.46	0.07	1.59
LIT-27	2.08	1.57	0.51	0.75	0.010	0.048	0.24	0.00	2.00	1.94	8.32	0.12	1.22
LIT-27	1.66	1.37	0.29	0.83	0.010	0.048	0.22	0.00	2.00	1.94	9.05	0.11	1.21
LIT-27	1.31	1.14	0.17	0.87	0.010	0.048	0.20	0.00	2.00	1.94	9.89	0.10	1.19
LIT-27	1.05	0.97	0.08	0.92	0.010	0.048	0.19	0.00	2.00	1.94	10.75	0.10	1.17
LIT-27	0.64	0.63	0.01	0.98	0.010	0.048	0.15	0.00	2.00	1.94	12.94	0.08	1.14
LIT-27	2.20	1.65	0.55	0.75	0.005	0.048	0.28	0.00	2.00	1.94	7.02	0.15	0.85
LIT-27	1.74	1.37	0.37	0.79	0.005	0.048	0.26	0.00	2.00	1.94	7.67	0.13	0.84
LIT-27	1.35	1.12	0.23	0.83	0.005	0.048	0.24	0.00	2.00	1.94	8.44	0.12	0.82
LIT-27	1.07	0.93	0.14	0.87	0.005	0.048	0.22	0.00	2.00	1.94	9.20	0.11	0.81
LIT-27	0.61	0.59	0.02	0.97	0.005	0.048	0.18	0.00	2.00	1.94	11.36	0.09	0.78
LIT-28	2.14	1.78	0.36	0.83	0.030	0.048	0.20	0.00	2.00	1.94	10.16	0.10	2.08
LIT-28	1.72	1.49	0.23	0.87	0.030	0.048	0.18	0.00	2.00	1.94	11.03	0.09	2.05
LIT-28	1.30	1.19	0.11	0.92	0.030	0.048	0.16	0.00	2.00	1.94	12.25	0.08	2.01
LIT-28	1.02	0.97	0.05	0.95	0.030	0.048	0.15	0.00	2.00	1.94	13.42	0.08	1.98
LIT-28	0.70	0.70	0.00	1.00	0.030	0.048	0.13	0.00	2.00	1.94	15.46	0.07	1.94
LIT-28	2.11	1.73	0.38	0.82	0.020	0.048	0.21	0.00	2.00	1.94	9.46	0.11	1.71
LIT-28	1.66	1.44	0.22	0.87	0.020	0.048	0.19	0.00	2.00	1.94	10.35	0.10	1.69
LIT-28	1.30	1.18	0.12	0.91	0.020	0.048	0.18	0.00	2.00	1.94	11.34	0.09	1.66
LIT-28	1.02	0.96	0.06	0.94	0.020	0.048	0.16	0.00	2.00	1.94	12.42	0.08	1.63
LIT-28	0.62	0.62	0.00	1.00	0.020	0.048	0.13	0.00	2.00	1.94	14.97	0.07	1.58
LIT-28	2.09	1.60	0.49	0.77	0.010	0.048	0.24	0.00	2.00	1.94	8.30	0.12	1.22
LIT-28	1.71	1.38	0.33	0.81	0.010	0.048	0.22	0.00	2.00	1.94	8.95	0.12	1.21
LIT-28	1.31	1.12	0.19	0.85	0.010	0.048	0.20	0.00	2.00	1.94	9.89	0.10	1.19

Continued on next page

Table 5: Literature-Derived Performance Data for Drop-Type Inlets — Continued

ID-CODE	Q_A	Q_I	Q_O	Q_R	S_0	S_x	d_a	h_b	L_I	W_I	L_R	W_R	Fr
LIT-28	0.95	0.86	0.09	0.91	0.010	0.048	0.18	0.00	2.00	1.94	11.16	0.09	1.16
LIT-28	0.60	0.59	0.01	0.98	0.010	0.048	0.15	0.00	2.00	1.94	13.26	0.08	1.13
LIT-28	2.19	1.58	0.61	0.72	0.005	0.048	0.28	0.00	2.00	1.94	7.04	0.15	0.85
LIT-28	1.80	1.36	0.44	0.76	0.005	0.048	0.26	0.00	2.00	1.94	7.57	0.14	0.84
LIT-28	1.35	1.09	0.26	0.81	0.005	0.048	0.24	0.00	2.00	1.94	8.44	0.12	0.82
LIT-28	0.98	0.84	0.14	0.86	0.005	0.048	0.21	0.00	2.00	1.94	9.51	0.11	0.81
LIT-28	0.61	0.57	0.04	0.93	0.005	0.048	0.18	0.00	2.00	1.94	11.36	0.09	0.78
LIT-29	1.96	1.45	0.51	0.74	0.030	0.048	0.19	0.00	1.08	1.94	5.69	0.10	2.07
LIT-29	1.58	1.24	0.34	0.78	0.030	0.048	0.18	0.00	1.08	1.94	6.17	0.09	2.04
LIT-29	1.27	1.06	0.21	0.83	0.030	0.048	0.16	0.00	1.08	1.94	6.70	0.08	2.01
LIT-29	1.03	0.92	0.11	0.89	0.030	0.048	0.15	0.00	1.08	1.94	7.24	0.08	1.98
LIT-29	0.68	0.68	0.00	1.00	0.030	0.048	0.13	0.00	1.08	1.94	8.46	0.07	1.93
LIT-29	2.00	1.42	0.58	0.71	0.020	0.048	0.21	0.00	1.08	1.94	5.23	0.11	1.70
LIT-29	1.56	1.23	0.33	0.79	0.020	0.048	0.19	0.00	1.08	1.94	5.74	0.10	1.68
LIT-29	1.28	1.12	0.16	0.88	0.020	0.048	0.18	0.00	1.08	1.94	6.18	0.09	1.66
LIT-29	0.99	0.92	0.07	0.93	0.020	0.048	0.16	0.00	1.08	1.94	6.81	0.08	1.63
LIT-29	0.63	0.62	0.01	0.98	0.020	0.048	0.13	0.00	1.08	1.94	8.06	0.07	1.59
LIT-29	1.65	1.29	0.36	0.78	0.020	0.048	0.19	0.00	1.08	1.94	5.62	0.10	1.68
LIT-29	2.08	1.34	0.74	0.64	0.010	0.048	0.24	0.00	1.08	1.94	4.51	0.12	1.22
LIT-29	1.66	1.26	0.40	0.76	0.010	0.048	0.22	0.00	1.08	1.94	4.90	0.11	1.21
LIT-29	1.30	1.04	0.26	0.80	0.010	0.048	0.20	0.00	1.08	1.94	5.38	0.10	1.19
LIT-29	1.04	0.88	0.16	0.85	0.010	0.048	0.19	0.00	1.08	1.94	5.84	0.10	1.17
LIT-29	0.60	0.56	0.04	0.93	0.010	0.048	0.15	0.00	1.08	1.94	7.18	0.08	1.13
LIT-29	1.95	1.30	0.65	0.67	0.010	0.048	0.23	0.00	1.08	1.94	4.62	0.12	1.22
LIT-30	2.01	1.67	0.34	0.83	0.020	0.048	0.21	0.00	2.00	1.94	9.63	0.11	1.71
LIT-30	1.60	1.40	0.20	0.88	0.020	0.048	0.19	0.00	2.00	1.94	10.49	0.10	1.68
LIT-30	1.27	1.16	0.11	0.91	0.020	0.048	0.17	0.00	2.00	1.94	11.44	0.09	1.66
LIT-30	1.03	0.97	0.06	0.94	0.020	0.048	0.16	0.00	2.00	1.94	12.38	0.08	1.64
LIT-30	0.64	0.64	0.00	1.00	0.020	0.048	0.14	0.00	2.00	1.94	14.80	0.07	1.59
LIT-31	1.58	1.09	0.49	0.69	0.030	0.048	0.18	0.00	2.13	1.35	12.10	0.13	2.04
LIT-31	1.27	0.96	0.31	0.76	0.030	0.048	0.16	0.00	2.13	1.35	13.13	0.12	2.01
LIT-31	1.03	0.82	0.21	0.80	0.030	0.048	0.15	0.00	2.13	1.35	14.21	0.11	1.98
LIT-31	0.78	0.66	0.12	0.85	0.030	0.048	0.13	0.00	2.13	1.35	15.77	0.10	1.95
LIT-31	0.60	0.55	0.05	0.92	0.030	0.048	0.12	0.00	2.13	1.35	17.40	0.09	1.92
LIT-31	0.35	0.34	0.01	0.97	0.030	0.048	0.10	0.00	2.13	1.35	21.30	0.07	1.85
LIT-31	1.86	1.25	0.61	0.67	0.020	0.048	0.20	0.00	2.13	1.35	10.54	0.15	1.70
LIT-31	1.42	1.05	0.37	0.74	0.020	0.048	0.18	0.00	2.13	1.35	11.66	0.13	1.67
LIT-31	1.11	0.88	0.23	0.79	0.020	0.048	0.17	0.00	2.13	1.35	12.79	0.12	1.64
LIT-31	0.82	0.70	0.12	0.85	0.020	0.048	0.15	0.00	2.13	1.35	14.33	0.11	1.61

Continued on next page

Table 5: Literature-Derived Performance Data for Drop-Type Inlets — Continued

ID-CODE	Q_A	Q_I	Q_O	Q_R	S_0	S_x	d_a	h_b	L_I	W_I	L_R	W_R	Fr
LIT-31	0.60	0.55	0.05	0.92	0.020	0.048	0.13	0.00	2.13	1.35	16.11	0.10	1.58
LIT-31	0.30	0.29	0.01	0.97	0.020	0.048	0.10	0.00	2.13	1.35	20.89	0.08	1.51
LIT-31	1.90	1.18	0.72	0.62	0.010	0.048	0.23	0.00	2.13	1.35	9.14	0.17	1.22
LIT-31	1.48	0.98	0.50	0.66	0.010	0.048	0.21	0.00	2.13	1.35	10.04	0.16	1.20
LIT-31	1.13	0.81	0.32	0.72	0.010	0.048	0.19	0.00	2.13	1.35	11.11	0.14	1.18
LIT-31	0.84	0.66	0.18	0.79	0.010	0.048	0.17	0.00	2.13	1.35	12.42	0.13	1.16
LIT-31	0.60	0.51	0.09	0.85	0.010	0.048	0.15	0.00	2.13	1.35	14.09	0.11	1.13
LIT-31	1.97	1.19	0.78	0.60	0.010	0.048	0.24	0.00	2.13	1.35	9.02	0.17	1.22
LIT-31	0.39	0.36	0.03	0.92	0.010	0.048	0.13	0.00	2.13	1.35	16.56	0.09	1.10
LIT-31	0.25	0.24	0.01	0.96	0.010	0.048	0.11	0.00	2.13	1.35	19.57	0.08	1.07
LIT-31	1.78	1.06	0.72	0.60	0.005	0.048	0.26	0.00	2.13	1.35	8.08	0.19	0.84
LIT-31	1.39	0.89	0.50	0.64	0.005	0.048	0.24	0.00	2.13	1.35	8.87	0.18	0.82
LIT-31	1.11	0.76	0.35	0.68	0.005	0.048	0.22	0.00	2.13	1.35	9.65	0.16	0.81
LIT-31	0.70	0.54	0.16	0.77	0.005	0.048	0.19	0.00	2.13	1.35	11.47	0.14	0.79
LIT-31	0.39	0.35	0.04	0.90	0.005	0.048	0.15	0.00	2.13	1.35	14.28	0.11	0.76
LIT-31	0.20	0.19	0.01	0.95	0.005	0.048	0.12	0.00	2.13	1.35	18.34	0.09	0.73
LIT-32	1.58	0.89	0.69	0.56	0.030	0.048	0.18	0.00	1.97	1.58	11.21	0.11	2.04
LIT-32	1.30	0.84	0.46	0.65	0.030	0.048	0.16	0.00	1.97	1.58	12.06	0.10	2.01
LIT-32	1.03	0.76	0.27	0.74	0.030	0.048	0.15	0.00	1.97	1.58	13.16	0.09	1.98
LIT-32	0.69	0.61	0.08	0.88	0.030	0.048	0.13	0.00	1.97	1.58	15.30	0.08	1.93
LIT-32	0.39	0.38	0.01	0.97	0.030	0.048	0.10	0.00	1.97	1.58	18.95	0.07	1.87
LIT-32	1.82	1.01	0.81	0.55	0.020	0.048	0.20	0.00	1.97	1.58	9.84	0.13	1.69
LIT-32	1.39	0.88	0.51	0.63	0.020	0.048	0.18	0.00	1.97	1.58	10.89	0.11	1.67
LIT-32	1.02	0.78	0.24	0.76	0.020	0.048	0.16	0.00	1.97	1.58	12.23	0.10	1.63
LIT-32	0.74	0.64	0.10	0.86	0.020	0.048	0.14	0.00	1.97	1.58	13.79	0.09	1.60
LIT-32	1.49	0.92	0.57	0.62	0.020	0.048	0.19	0.00	1.97	1.58	10.61	0.12	1.67
LIT-32	0.50	0.49	0.01	0.98	0.020	0.048	0.12	0.00	1.97	1.58	15.98	0.08	1.56
LIT-32	1.80	1.03	0.77	0.57	0.010	0.048	0.23	0.00	1.97	1.58	8.65	0.14	1.21
LIT-32	1.35	0.90	0.45	0.67	0.010	0.048	0.20	0.00	1.97	1.58	9.63	0.13	1.19
LIT-32	1.01	0.76	0.25	0.75	0.010	0.048	0.18	0.00	1.97	1.58	10.74	0.12	1.17
LIT-32	0.65	0.57	0.08	0.88	0.010	0.048	0.16	0.00	1.97	1.58	12.67	0.10	1.14
LIT-32	0.30	0.29	0.01	0.97	0.010	0.048	0.12	0.00	1.97	1.58	16.93	0.07	1.08
LIT-32	2.01	1.08	0.93	0.54	0.005	0.048	0.28	0.00	1.97	1.58	7.15	0.17	0.84
LIT-32	1.45	0.93	0.52	0.64	0.005	0.048	0.24	0.00	1.97	1.58	8.08	0.15	0.83
LIT-32	1.11	0.79	0.32	0.71	0.005	0.048	0.22	0.00	1.97	1.58	8.94	0.14	0.81
LIT-32	0.70	0.57	0.13	0.81	0.005	0.048	0.19	0.00	1.97	1.58	10.62	0.12	0.79
LIT-32	0.39	0.36	0.03	0.92	0.005	0.048	0.15	0.00	1.97	1.58	13.23	0.09	0.76
LIT-32	0.23	0.22	0.01	0.96	0.005	0.048	0.12	0.00	1.97	1.58	16.13	0.08	0.74
LIT-33	2.02	1.51	0.51	0.75	0.030	0.048	0.19	0.00	1.58	2.00	8.22	0.10	2.07

Continued on next page

Table 5: Literature-Derived Performance Data for Drop-Type Inlets — Continued

ID-CODE	Q_A	Q_I	Q_O	Q_R	S_0	S_x	d_a	h_b	L_I	W_I	L_R	W_R	Fr
LIT-33	1.48	1.24	0.24	0.84	0.030	0.048	0.17	0.00	1.58	2.00	9.24	0.09	2.03
LIT-33	1.19	1.07	0.12	0.90	0.030	0.048	0.16	0.00	1.58	2.00	10.03	0.08	2.00
LIT-33	0.87	0.84	0.03	0.97	0.030	0.048	0.14	0.00	1.58	2.00	11.28	0.07	1.96
LIT-33	0.62	0.61	0.01	0.98	0.030	0.048	0.12	0.00	1.58	2.00	12.81	0.06	1.92
LIT-33	1.99	1.58	0.41	0.79	0.020	0.048	0.21	0.00	1.58	2.00	7.66	0.10	1.70
LIT-33	1.50	1.31	0.19	0.87	0.020	0.048	0.19	0.00	1.58	2.00	8.51	0.09	1.67
LIT-33	1.20	1.11	0.09	0.93	0.020	0.048	0.17	0.00	1.58	2.00	9.25	0.09	1.65
LIT-33	0.88	0.86	0.02	0.98	0.020	0.048	0.15	0.00	1.58	2.00	10.40	0.08	1.62
LIT-33	0.65	0.65	0.00	1.00	0.020	0.048	0.14	0.00	1.58	2.00	11.65	0.07	1.59
LIT-33	1.96	1.55	0.41	0.79	0.010	0.048	0.24	0.00	1.58	2.00	6.73	0.12	1.22
LIT-33	1.60	1.34	0.26	0.84	0.010	0.048	0.22	0.00	1.58	2.00	7.27	0.11	1.20
LIT-33	1.24	1.10	0.14	0.89	0.010	0.048	0.20	0.00	1.58	2.00	8.00	0.10	1.18
LIT-33	0.89	0.84	0.05	0.94	0.010	0.048	0.17	0.00	1.58	2.00	9.06	0.09	1.16
LIT-33	0.65	0.64	0.01	0.98	0.010	0.048	0.16	0.00	1.58	2.00	10.19	0.08	1.14
LIT-33	2.06	1.55	0.51	0.75	0.005	0.048	0.28	0.00	1.58	2.00	5.70	0.14	0.84
LIT-33	1.45	1.18	0.27	0.81	0.005	0.048	0.24	0.00	1.58	2.00	6.50	0.12	0.83
LIT-33	1.70	1.34	0.36	0.79	0.005	0.048	0.26	0.00	1.58	2.00	6.13	0.13	0.83
LIT-33	1.11	0.94	0.17	0.85	0.005	0.048	0.22	0.00	1.58	2.00	7.19	0.11	0.81
LIT-33	0.81	0.74	0.07	0.91	0.005	0.048	0.20	0.00	1.58	2.00	8.09	0.10	0.80
LIT-33	0.61	0.58	0.03	0.95	0.005	0.048	0.18	0.00	1.58	2.00	9.00	0.09	0.78
LIT-34	2.10	1.68	0.42	0.80	0.030	0.048	0.20	0.00	1.33	2.00	6.82	0.10	2.07
LIT-34	1.62	1.38	0.24	0.85	0.030	0.048	0.18	0.00	1.33	2.00	7.52	0.09	2.04
LIT-34	1.26	1.12	0.14	0.89	0.030	0.048	0.16	0.00	1.33	2.00	8.27	0.08	2.01
LIT-34	0.94	0.87	0.07	0.93	0.030	0.048	0.14	0.00	1.33	2.00	9.23	0.07	1.97
LIT-34	0.62	0.60	0.02	0.97	0.030	0.048	0.12	0.00	1.33	2.00	10.78	0.06	1.92
LIT-34	0.30	0.29	0.01	0.97	0.030	0.048	0.09	0.00	1.33	2.00	14.16	0.05	1.84
LIT-34	2.14	1.67	0.47	0.78	0.020	0.048	0.21	0.00	1.33	2.00	6.27	0.11	1.71
LIT-34	1.61	1.36	0.25	0.84	0.020	0.048	0.19	0.00	1.33	2.00	6.98	0.10	1.68
LIT-34	1.24	1.10	0.14	0.89	0.020	0.048	0.17	0.00	1.33	2.00	7.70	0.09	1.65
LIT-34	0.92	0.85	0.07	0.92	0.020	0.048	0.15	0.00	1.33	2.00	8.61	0.08	1.62
LIT-34	0.61	0.58	0.03	0.95	0.020	0.048	0.13	0.00	1.33	2.00	10.04	0.07	1.58
LIT-34	0.25	0.24	0.01	0.96	0.020	0.048	0.10	0.00	1.33	2.00	14.03	0.05	1.50
LIT-34	2.21	1.60	0.61	0.72	0.010	0.048	0.25	0.00	1.33	2.00	5.42	0.12	1.23
LIT-34	1.67	1.30	0.37	0.78	0.010	0.048	0.22	0.00	1.33	2.00	6.02	0.11	1.21
LIT-34	1.32	1.08	0.24	0.82	0.010	0.048	0.20	0.00	1.33	2.00	6.58	0.10	1.19
LIT-34	0.91	0.79	0.12	0.87	0.010	0.048	0.18	0.00	1.33	2.00	7.56	0.09	1.16
LIT-34	0.62	0.58	0.04	0.94	0.010	0.048	0.15	0.00	1.33	2.00	8.73	0.08	1.13
LIT-34	0.30	0.29	0.01	0.97	0.010	0.048	0.12	0.00	1.33	2.00	11.47	0.06	1.08
LIT-34	2.44	1.63	0.81	0.67	0.005	0.048	0.30	0.00	1.33	2.00	4.50	0.15	0.85

Continued on next page

Table 5: Literature-Derived Performance Data for Drop-Type Inlets — Continued

ID-CODE	Q_A	Q_I	Q_O	Q_R	S_0	S_x	d_a	h_b	L_I	W_I	L_R	W_R	Fr
LIT-34	1.93	1.37	0.56	0.71	0.005	0.048	0.27	0.00	1.33	2.00	4.92	0.14	0.84
LIT-34	1.50	1.13	0.37	0.75	0.005	0.048	0.25	0.00	1.33	2.00	5.41	0.12	0.83
LIT-34	1.18	0.93	0.25	0.79	0.005	0.048	0.23	0.00	1.33	2.00	5.92	0.11	0.82
LIT-34	0.84	0.70	0.14	0.83	0.005	0.048	0.20	0.00	1.33	2.00	6.72	0.10	0.80
LIT-34	0.61	0.53	0.08	0.87	0.005	0.048	0.18	0.00	1.33	2.00	7.58	0.09	0.78
LIT-34	0.30	0.28	0.02	0.93	0.005	0.048	0.13	0.00	1.33	2.00	9.89	0.07	0.75
LIT-34	0.15	0.14	0.01	0.93	0.005	0.048	0.10	0.00	1.33	2.00	12.82	0.05	0.72
LIT-35	2.11	1.34	0.77	0.64	0.030	0.048	0.20	0.00	1.33	2.00	6.81	0.10	2.07
LIT-35	1.59	1.16	0.43	0.73	0.030	0.048	0.18	0.00	1.33	2.00	7.58	0.09	2.04
LIT-35	1.25	0.98	0.27	0.78	0.030	0.048	0.16	0.00	1.33	2.00	8.29	0.08	2.01
LIT-35	0.94	0.79	0.15	0.84	0.030	0.048	0.14	0.00	1.33	2.00	9.23	0.07	1.97
LIT-35	0.62	0.56	0.06	0.90	0.030	0.048	0.12	0.00	1.33	2.00	10.78	0.06	1.92
LIT-35	0.39	0.38	0.01	0.97	0.030	0.048	0.10	0.00	1.33	2.00	12.83	0.05	1.87
LIT-35	2.11	1.37	0.74	0.65	0.020	0.048	0.21	0.00	1.33	2.00	6.31	0.11	1.71
LIT-35	1.60	1.14	0.46	0.71	0.020	0.048	0.19	0.00	1.33	2.00	7.00	0.10	1.68
LIT-35	1.27	1.04	0.23	0.82	0.020	0.048	0.17	0.00	1.33	2.00	7.63	0.09	1.66
LIT-35	0.94	0.82	0.12	0.87	0.020	0.048	0.16	0.00	1.33	2.00	8.54	0.08	1.63
LIT-35	1.63	1.19	0.44	0.73	0.020	0.048	0.19	0.00	1.33	2.00	6.95	0.10	1.68
LIT-35	0.62	0.57	0.05	0.92	0.020	0.048	0.13	0.00	1.33	2.00	9.98	0.07	1.58
LIT-35	0.38	0.38	0.00	1.00	0.020	0.048	0.11	0.00	1.33	2.00	11.99	0.06	1.54
LIT-35	2.21	1.39	0.82	0.63	0.010	0.048	0.25	0.00	1.33	2.00	5.42	0.12	1.23
LIT-35	1.65	1.19	0.46	0.72	0.010	0.048	0.22	0.00	1.33	2.00	6.05	0.11	1.21
LIT-35	1.30	1.04	0.26	0.80	0.010	0.048	0.20	0.00	1.33	2.00	6.62	0.10	1.19
LIT-35	0.96	0.82	0.14	0.85	0.010	0.048	0.18	0.00	1.33	2.00	7.41	0.09	1.17
LIT-35	0.62	0.58	0.04	0.94	0.010	0.048	0.15	0.00	1.33	2.00	8.73	0.08	1.13
LIT-35	0.39	0.39	0.00	1.00	0.010	0.048	0.13	0.00	1.33	2.00	10.39	0.06	1.10
LIT-35	2.29	1.37	0.92	0.60	0.005	0.048	0.29	0.00	1.33	2.00	4.61	0.14	0.85
LIT-35	1.76	1.20	0.56	0.68	0.005	0.048	0.26	0.00	1.33	2.00	5.09	0.13	0.84
LIT-35	1.37	1.04	0.33	0.76	0.005	0.048	0.24	0.00	1.33	2.00	5.59	0.12	0.82
LIT-35	1.03	0.85	0.18	0.83	0.005	0.048	0.21	0.00	1.33	2.00	6.22	0.11	0.81
LIT-35	0.63	0.56	0.07	0.89	0.005	0.048	0.18	0.00	1.33	2.00	7.48	0.09	0.78
LIT-35	0.34	0.33	0.01	0.97	0.005	0.048	0.14	0.00	1.33	2.00	9.43	0.07	0.75
LIT-36	2.03	1.51	0.52	0.74	0.030	0.048	0.19	0.00	1.33	2.00	6.91	0.10	2.07
LIT-36	1.64	1.31	0.33	0.80	0.030	0.048	0.18	0.00	1.33	2.00	7.49	0.09	2.04
LIT-36	1.27	1.06	0.21	0.83	0.030	0.048	0.16	0.00	1.33	2.00	8.24	0.08	2.01
LIT-36	1.00	0.88	0.12	0.88	0.030	0.048	0.15	0.00	1.33	2.00	9.01	0.07	1.98
LIT-36	0.73	0.67	0.06	0.92	0.030	0.048	0.13	0.00	1.33	2.00	10.14	0.07	1.94
LIT-36	0.34	0.33	0.01	0.97	0.030	0.048	0.10	0.00	1.33	2.00	13.51	0.05	1.85
LIT-36	2.09	1.52	0.57	0.73	0.020	0.048	0.21	0.00	1.33	2.00	6.33	0.11	1.71

Continued on next page

Table 5: Literature-Derived Performance Data for Drop-Type Inlets — Continued

ID-CODE	Q_A	Q_I	Q_O	Q_R	S_0	S_x	d_a	h_b	L_I	W_I	L_R	W_R	Fr
LIT-36	1.66	1.31	0.35	0.79	0.020	0.048	0.19	0.00	1.33	2.00	6.90	0.10	1.69
LIT-36	1.31	1.10	0.21	0.84	0.020	0.048	0.18	0.00	1.33	2.00	7.54	0.09	1.66
LIT-36	1.01	0.89	0.12	0.88	0.020	0.048	0.16	0.00	1.33	2.00	8.31	0.08	1.63
LIT-36	0.70	0.65	0.05	0.93	0.020	0.048	0.14	0.00	1.33	2.00	9.54	0.07	1.60
LIT-36	0.40	0.40	0.00	1.00	0.020	0.048	0.11	0.00	1.33	2.00	11.77	0.06	1.54
LIT-36	2.15	1.50	0.65	0.70	0.010	0.048	0.24	0.00	1.33	2.00	5.48	0.12	1.23
LIT-36	1.74	1.30	0.44	0.75	0.010	0.048	0.22	0.00	1.33	2.00	5.93	0.11	1.21
LIT-36	1.36	1.10	0.26	0.81	0.010	0.048	0.20	0.00	1.33	2.00	6.50	0.10	1.19
LIT-36	1.05	0.91	0.14	0.87	0.010	0.048	0.19	0.00	1.33	2.00	7.17	0.09	1.17
LIT-36	0.68	0.64	0.04	0.94	0.010	0.048	0.16	0.00	1.33	2.00	8.44	0.08	1.14
LIT-36	0.37	0.37	0.00	1.00	0.010	0.048	0.13	0.00	1.33	2.00	10.60	0.06	1.10
LIT-36	2.33	1.52	0.81	0.65	0.005	0.048	0.29	0.00	1.33	2.00	4.58	0.15	0.85
LIT-36	1.81	1.30	0.51	0.72	0.005	0.048	0.26	0.00	1.33	2.00	5.04	0.13	0.84
LIT-36	1.41	1.09	0.32	0.77	0.005	0.048	0.24	0.00	1.33	2.00	5.53	0.12	0.82
LIT-36	0.98	0.82	0.16	0.84	0.005	0.048	0.21	0.00	1.33	2.00	6.34	0.11	0.81
LIT-36	0.61	0.55	0.06	0.90	0.005	0.048	0.18	0.00	1.33	2.00	7.58	0.09	0.78
LIT-36	0.31	0.30	0.01	0.97	0.005	0.048	0.14	0.00	1.33	2.00	9.76	0.07	0.75
LIT-37	2.03	1.55	0.48	0.76	0.030	0.048	0.19	0.00	1.33	2.00	6.91	0.10	2.07
LIT-37	1.61	1.32	0.29	0.82	0.030	0.048	0.18	0.00	1.33	2.00	7.54	0.09	2.04
LIT-37	1.29	1.11	0.18	0.86	0.030	0.048	0.16	0.00	1.33	2.00	8.19	0.08	2.01
LIT-37	0.95	0.86	0.09	0.91	0.030	0.048	0.15	0.00	1.33	2.00	9.19	0.07	1.97
LIT-37	0.60	0.58	0.02	0.97	0.030	0.048	0.12	0.00	1.33	2.00	10.92	0.06	1.92
LIT-37	2.09	1.55	0.54	0.74	0.020	0.048	0.21	0.00	1.33	2.00	6.33	0.11	1.71
LIT-37	1.64	1.34	0.30	0.82	0.020	0.048	0.19	0.00	1.33	2.00	6.93	0.10	1.68
LIT-37	1.27	1.11	0.16	0.87	0.020	0.048	0.17	0.00	1.33	2.00	7.63	0.09	1.66
LIT-37	0.96	0.88	0.08	0.92	0.020	0.048	0.16	0.00	1.33	2.00	8.47	0.08	1.63
LIT-37	0.58	0.57	0.01	0.98	0.020	0.048	0.13	0.00	1.33	2.00	10.24	0.07	1.58
LIT-37	2.17	1.56	0.61	0.72	0.010	0.048	0.24	0.00	1.33	2.00	5.46	0.12	1.23
LIT-37	1.66	1.30	0.36	0.78	0.010	0.048	0.22	0.00	1.33	2.00	6.04	0.11	1.21
LIT-37	1.31	1.10	0.21	0.84	0.010	0.048	0.20	0.00	1.33	2.00	6.60	0.10	1.19
LIT-37	0.93	0.83	0.10	0.89	0.010	0.048	0.18	0.00	1.33	2.00	7.50	0.09	1.16
LIT-37	0.60	0.58	0.02	0.97	0.010	0.048	0.15	0.00	1.33	2.00	8.84	0.08	1.13
LIT-37	2.29	1.57	0.72	0.69	0.005	0.048	0.29	0.00	1.33	2.00	4.61	0.14	0.85
LIT-37	1.78	1.32	0.46	0.74	0.005	0.048	0.26	0.00	1.33	2.00	5.07	0.13	0.84
LIT-37	1.36	1.07	0.29	0.79	0.005	0.048	0.24	0.00	1.33	2.00	5.61	0.12	0.82
LIT-37	0.98	0.83	0.15	0.85	0.005	0.048	0.21	0.00	1.33	2.00	6.34	0.11	0.81
LIT-37	0.69	0.61	0.08	0.88	0.005	0.048	0.18	0.00	1.33	2.00	7.23	0.09	0.79
LIT-37	0.31	0.30	0.01	0.97	0.005	0.048	0.14	0.00	1.33	2.00	9.76	0.07	0.75
LIT-38	2.13	1.64	0.49	0.77	0.030	0.048	0.20	0.00	2.00	2.00	10.18	0.10	2.08

Continued on next page

Table 5: Literature-Derived Performance Data for Drop-Type Inlets — Continued

ID-CODE	Q_A	Q_I	Q_O	Q_R	S_0	S_x	d_a	h_b	L_I	W_I	L_R	W_R	Fr
LIT-38	1.72	1.42	0.30	0.83	0.030	0.048	0.18	0.00	2.00	2.00	11.03	0.09	2.05
LIT-38	1.42	1.25	0.17	0.88	0.030	0.048	0.17	0.00	2.00	2.00	11.85	0.08	2.02
LIT-38	1.11	1.02	0.09	0.92	0.030	0.048	0.15	0.00	2.00	2.00	13.00	0.08	1.99
LIT-38	0.88	0.84	0.04	0.95	0.030	0.048	0.14	0.00	2.00	2.00	14.18	0.07	1.96
LIT-38	0.65	0.65	0.00	1.00	0.030	0.048	0.13	0.00	2.00	2.00	15.89	0.06	1.93
LIT-38	1.76	1.44	0.32	0.82	0.030	0.048	0.18	0.00	2.00	2.00	10.94	0.09	2.05
LIT-38	2.04	1.60	0.44	0.78	0.030	0.048	0.19	0.00	2.00	2.00	10.35	0.10	2.07
LIT-38	2.11	1.61	0.50	0.76	0.020	0.048	0.21	0.00	2.00	2.00	9.46	0.11	1.71
LIT-38	1.74	1.45	0.29	0.83	0.020	0.048	0.20	0.00	2.00	2.00	10.17	0.10	1.69
LIT-38	1.40	1.23	0.17	0.88	0.020	0.048	0.18	0.00	2.00	2.00	11.03	0.09	1.67
LIT-38	1.11	1.01	0.10	0.91	0.020	0.048	0.17	0.00	2.00	2.00	12.04	0.08	1.64
LIT-38	0.84	0.80	0.04	0.95	0.020	0.048	0.15	0.00	2.00	2.00	13.36	0.07	1.61
LIT-38	0.60	0.60	0.00	1.00	0.020	0.048	0.13	0.00	2.00	2.00	15.16	0.07	1.58
LIT-38	1.20	1.08	0.12	0.90	0.020	0.048	0.17	0.00	2.00	2.00	11.69	0.09	1.65
LIT-38	1.97	1.55	0.42	0.79	0.020	0.048	0.21	0.00	2.00	2.00	9.71	0.10	1.70
LIT-38	1.58	1.34	0.24	0.85	0.020	0.048	0.19	0.00	2.00	2.00	10.54	0.09	1.68
LIT-38	2.21	1.58	0.63	0.71	0.010	0.048	0.25	0.00	2.00	2.00	8.13	0.12	1.23
LIT-38	1.71	1.33	0.38	0.78	0.010	0.048	0.22	0.00	2.00	2.00	8.95	0.11	1.21
LIT-38	1.30	1.08	0.22	0.83	0.010	0.048	0.20	0.00	2.00	2.00	9.92	0.10	1.19
LIT-38	0.96	0.85	0.11	0.89	0.010	0.048	0.18	0.00	2.00	2.00	11.12	0.09	1.17
LIT-38	0.61	0.59	0.02	0.97	0.010	0.048	0.15	0.00	2.00	2.00	13.18	0.08	1.13
LIT-38	0.41	0.41	0.00	1.00	0.010	0.048	0.13	0.00	2.00	2.00	15.30	0.07	1.11
LIT-38	2.32	1.52	0.80	0.66	0.005	0.048	0.29	0.00	2.00	2.00	6.89	0.15	0.85
LIT-38	1.78	1.26	0.52	0.71	0.005	0.048	0.26	0.00	2.00	2.00	7.60	0.13	0.84
LIT-38	1.37	1.04	0.33	0.76	0.005	0.048	0.24	0.00	2.00	2.00	8.39	0.12	0.82
LIT-38	0.97	0.81	0.16	0.84	0.005	0.048	0.21	0.00	2.00	2.00	9.55	0.10	0.81
LIT-38	0.61	0.56	0.05	0.92	0.005	0.048	0.18	0.00	2.00	2.00	11.36	0.09	0.78
LIT-38	0.30	0.30	0.00	1.00	0.005	0.048	0.13	0.00	2.00	2.00	14.83	0.07	0.75
LIT-39	1.32	1.14	0.19	0.86	0.005	0.031	0.07	0.00	2.46	1.48	36.27	0.05	5.18
LIT-39	2.06	1.78	0.28	0.86	0.005	0.031	0.12	0.00	2.46	1.48	20.60	0.08	2.77
LIT-39	2.65	2.16	0.49	0.82	0.005	0.031	0.15	0.00	2.46	1.48	16.74	0.10	2.30
LIT-39	3.49	2.63	0.86	0.75	0.005	0.031	0.18	0.00	2.46	1.48	13.89	0.12	1.99
LIT-39	4.32	3.08	1.24	0.71	0.005	0.031	0.21	0.00	2.46	1.48	11.94	0.14	1.77
LIT-39	5.14	3.48	1.66	0.68	0.005	0.031	0.23	0.00	2.46	1.48	10.74	0.16	1.64
LIT-39	5.83	3.82	2.01	0.65	0.005	0.031	0.25	0.00	2.46	1.48	9.91	0.17	1.55
LIT-39	6.94	4.32	2.63	0.62	0.005	0.031	0.28	0.00	2.46	1.48	8.93	0.19	1.45
LIT-39	1.13	1.05	0.08	0.93	0.010	0.031	0.06	0.00	2.46	1.48	41.11	0.04	5.78
LIT-39	2.31	1.73	0.58	0.75	0.010	0.031	0.12	0.00	2.46	1.48	21.07	0.08	3.03
LIT-39	3.31	2.51	0.80	0.76	0.010	0.031	0.17	0.00	2.46	1.48	14.54	0.11	2.08

Continued on next page

Table 5: Literature-Derived Performance Data for Drop-Type Inlets — Continued

ID-CODE	Q_A	Q_I	Q_O	Q_R	S_0	S_x	d_a	h_b	L_I	W_I	L_R	W_R	Fr
LIT-39	4.47	3.10	1.36	0.69	0.010	0.031	0.21	0.00	2.46	1.48	11.92	0.14	1.79
LIT-39	5.32	3.51	1.81	0.66	0.010	0.031	0.23	0.00	2.46	1.48	10.66	0.16	1.65
LIT-39	6.43	4.04	2.39	0.63	0.010	0.031	0.26	0.00	2.46	1.48	9.47	0.18	1.52
LIT-39	7.27	4.46	2.81	0.61	0.010	0.031	0.28	0.00	2.46	1.48	8.70	0.19	1.43
LIT-39	0.65	0.61	0.04	0.94	0.020	0.031	0.01	0.00	2.46	1.48	173.78	0.01	38.02
LIT-39	1.20	1.06	0.13	0.89	0.020	0.031	0.06	0.00	2.46	1.48	40.50	0.04	5.81
LIT-39	1.79	1.41	0.38	0.79	0.020	0.031	0.09	0.00	2.46	1.48	27.20	0.06	3.91
LIT-39	2.18	1.81	0.37	0.83	0.020	0.031	0.12	0.00	2.46	1.48	20.27	0.08	2.78
LIT-39	3.16	2.40	0.76	0.76	0.020	0.031	0.16	0.00	2.46	1.48	15.18	0.11	2.17
LIT-39	4.18	3.06	1.12	0.73	0.020	0.031	0.20	0.00	2.46	1.48	12.07	0.14	1.77
LIT-39	5.30	3.64	1.67	0.69	0.020	0.031	0.24	0.00	2.46	1.48	10.35	0.16	1.58
LIT-39	6.34	4.12	2.22	0.65	0.020	0.031	0.27	0.00	2.46	1.48	9.28	0.18	1.47
LIT-39	7.64	4.71	2.92	0.62	0.020	0.031	0.30	0.00	2.46	1.48	8.30	0.20	1.36
LIT-39	0.83	0.80	0.03	0.96	0.030	0.031	0.04	0.00	2.46	1.48	69.34	0.02	10.86
LIT-39	1.92	1.48	0.45	0.77	0.030	0.031	0.10	0.00	2.46	1.48	25.59	0.07	3.70
LIT-39	2.50	2.11	0.39	0.84	0.030	0.031	0.14	0.00	2.46	1.48	17.22	0.10	2.33
LIT-39	3.35	2.59	0.76	0.77	0.030	0.031	0.17	0.00	2.46	1.48	14.09	0.12	2.00
LIT-39	4.61	3.20	1.42	0.69	0.030	0.031	0.21	0.00	2.46	1.48	11.59	0.14	1.75
LIT-39	5.72	3.80	1.92	0.66	0.030	0.031	0.25	0.00	2.46	1.48	9.96	0.17	1.55
LIT-39	6.80	4.31	2.49	0.63	0.030	0.031	0.28	0.00	2.46	1.48	8.94	0.19	1.44
LIT-39	7.92	4.89	3.03	0.62	0.030	0.031	0.31	0.00	2.46	1.48	8.05	0.21	1.32
LIT-39	8.49	5.11	3.38	0.60	0.030	0.031	0.31	0.00	2.46	1.48	7.82	0.21	1.31
LIT-39	0.72	0.73	-0.01	1.02	0.050	0.031	0.03	0.00	2.46	1.48	84.60	0.02	13.58
LIT-39	0.98	0.90	0.08	0.92	0.050	0.031	0.05	0.00	2.46	1.48	53.76	0.03	8.04
LIT-39	2.37	1.86	0.51	0.79	0.050	0.031	0.13	0.00	2.46	1.48	19.53	0.09	2.74
LIT-39	3.16	2.49	0.67	0.79	0.050	0.031	0.17	0.00	2.46	1.48	14.57	0.11	2.04
LIT-39	3.91	2.97	0.94	0.76	0.050	0.031	0.20	0.00	2.46	1.48	12.38	0.13	1.77
LIT-39	4.83	3.48	1.35	0.72	0.050	0.031	0.23	0.00	2.46	1.48	10.75	0.16	1.60
LIT-39	5.84	3.98	1.86	0.68	0.050	0.031	0.26	0.00	2.46	1.48	9.56	0.17	1.47
LIT-39	6.63	4.35	2.28	0.66	0.050	0.031	0.28	0.00	2.46	1.48	8.88	0.19	1.40
LIT-39	7.49	4.70	2.78	0.63	0.050	0.031	0.30	0.00	2.46	1.48	8.31	0.20	1.35
LIT-39	8.03	4.89	3.14	0.61	0.050	0.031	0.31	0.00	2.46	1.48	8.06	0.21	1.34
LIT-39	8.91	5.19	3.72	0.58	0.050	0.031	0.32	0.00	2.46	1.48	7.67	0.22	1.31
LIT-39	0.84	0.68	0.16	0.80	0.005	0.016	0.02	0.00	2.46	1.48	108.70	0.02	15.38
LIT-39	1.37	0.92	0.46	0.67	0.005	0.016	0.04	0.00	2.46	1.48	56.31	0.03	7.33
LIT-39	1.58	1.24	0.34	0.79	0.005	0.016	0.08	0.00	2.46	1.48	32.13	0.05	3.39
LIT-39	2.46	1.67	0.79	0.68	0.005	0.016	0.11	0.00	2.46	1.48	22.25	0.07	2.44
LIT-39	2.96	1.93	1.03	0.65	0.005	0.016	0.13	0.00	2.46	1.48	19.31	0.09	2.16
LIT-39	3.59	2.22	1.37	0.62	0.005	0.016	0.15	0.00	2.46	1.48	16.50	0.10	1.88

Continued on next page

Table 5: Literature-Derived Performance Data for Drop-Type Inlets — Continued

ID-CODE	Q_A	Q_I	Q_O	Q_R	S_0	S_x	d_a	h_b	L_I	W_I	L_R	W_R	Fr
LIT-39	4.18	2.50	1.68	0.60	0.005	0.016	0.17	0.00	2.46	1.48	14.56	0.11	1.68
LIT-39	4.75	2.74	2.01	0.58	0.005	0.016	0.18	0.00	2.46	1.48	13.50	0.12	1.60
LIT-39	5.84	3.14	2.70	0.54	0.005	0.016	0.21	0.00	2.46	1.48	11.79	0.14	1.45
LIT-39	0.99	0.85	0.14	0.86	0.010	0.016	0.04	0.00	2.46	1.48	67.57	0.02	8.17
LIT-39	1.58	1.11	0.48	0.70	0.010	0.016	0.06	0.00	2.46	1.48	38.17	0.04	4.39
LIT-39	1.82	1.43	0.39	0.78	0.010	0.016	0.12	0.00	2.46	1.48	21.25	0.08	1.96
LIT-39	2.53	1.73	0.80	0.69	0.010	0.016	0.12	0.00	2.46	1.48	21.27	0.08	2.31
LIT-39	3.53	2.17	1.36	0.62	0.010	0.016	0.15	0.00	2.46	1.48	16.64	0.10	1.89
LIT-39	4.19	2.43	1.76	0.58	0.010	0.016	0.16	0.00	2.46	1.48	15.02	0.11	1.76
LIT-39	5.29	2.82	2.47	0.53	0.010	0.016	0.19	0.00	2.46	1.48	13.01	0.13	1.60
LIT-39	6.06	3.05	3.01	0.50	0.010	0.016	0.20	0.00	2.46	1.48	12.09	0.14	1.53
LIT-39	1.17	0.98	0.19	0.84	0.020	0.016	0.05	0.00	2.46	1.48	45.87	0.04	4.97
LIT-39	1.85	1.29	0.56	0.70	0.020	0.016	0.08	0.00	2.46	1.48	30.31	0.05	3.36
LIT-39	2.30	1.75	0.54	0.76	0.020	0.016	0.12	0.00	2.46	1.48	20.96	0.08	2.15
LIT-39	3.20	2.18	1.02	0.68	0.020	0.016	0.15	0.00	2.46	1.48	16.62	0.10	1.79
LIT-39	4.02	2.53	1.49	0.63	0.020	0.016	0.17	0.00	2.46	1.48	14.39	0.12	1.62
LIT-39	4.66	2.76	1.91	0.59	0.020	0.016	0.19	0.00	2.46	1.48	13.28	0.13	1.55
LIT-39	5.41	3.05	2.36	0.56	0.020	0.016	0.20	0.00	2.46	1.48	12.10	0.14	1.45
LIT-39	6.15	3.34	2.80	0.54	0.020	0.016	0.22	0.00	2.46	1.48	11.14	0.15	1.37
LIT-39	7.05	3.64	3.41	0.52	0.020	0.016	0.24	0.00	2.46	1.48	10.40	0.16	1.32
LIT-39	8.03	3.96	4.07	0.49	0.020	0.016	0.25	0.00	2.46	1.48	9.65	0.17	1.26
LIT-39	1.10	0.99	0.12	0.90	0.030	0.016	0.05	0.00	2.46	1.48	45.35	0.04	4.75
LIT-39	1.51	1.23	0.28	0.82	0.030	0.016	0.08	0.00	2.46	1.48	32.34	0.05	3.35
LIT-39	1.90	1.62	0.28	0.85	0.030	0.016	0.11	0.00	2.46	1.48	22.76	0.07	2.21
LIT-39	2.89	2.14	0.75	0.74	0.030	0.016	0.15	0.00	2.46	1.48	16.88	0.10	1.75
LIT-39	3.88	2.61	1.26	0.67	0.030	0.016	0.18	0.00	2.46	1.48	13.96	0.12	1.52
LIT-39	4.71	2.97	1.73	0.63	0.030	0.016	0.20	0.00	2.46	1.48	12.35	0.13	1.39
LIT-39	5.72	3.37	2.35	0.59	0.030	0.016	0.22	0.00	2.46	1.48	11.05	0.15	1.30
LIT-39	6.62	3.70	2.92	0.56	0.030	0.016	0.24	0.00	2.46	1.48	10.19	0.16	1.24
LIT-39	7.43	3.98	3.44	0.54	0.030	0.016	0.26	0.00	2.46	1.48	9.57	0.17	1.19
LIT-39	1.05	0.97	0.08	0.92	0.050	0.016	0.05	0.00	2.46	1.48	47.36	0.04	4.93
LIT-39	2.08	1.58	0.49	0.76	0.050	0.016	0.11	0.00	2.46	1.48	23.30	0.07	2.40
LIT-39	2.57	2.09	0.48	0.81	0.050	0.016	0.14	0.00	2.46	1.48	17.32	0.10	1.71
LIT-39	3.30	2.47	0.83	0.75	0.050	0.016	0.17	0.00	2.46	1.48	14.68	0.11	1.51
LIT-39	4.19	2.89	1.30	0.69	0.050	0.016	0.19	0.00	2.46	1.48	12.69	0.13	1.37
LIT-39	5.11	3.28	1.83	0.64	0.050	0.016	0.22	0.00	2.46	1.48	11.32	0.15	1.27
LIT-39	5.93	3.58	2.35	0.60	0.050	0.016	0.23	0.00	2.46	1.48	10.48	0.16	1.22
LIT-39	7.23	4.09	3.14	0.57	0.050	0.016	0.26	0.00	2.46	1.48	9.35	0.18	1.14
LIT-39	8.30	4.49	3.81	0.54	0.050	0.016	0.28	0.00	2.46	1.48	8.63	0.19	1.08

Continued on next page

Table 5: Literature-Derived Performance Data for Drop-Type Inlets — Continued

ID-CODE	Q_A	Q_I	Q_O	Q_R	S_0	S_x	d_a	h_b	L_I	W_I	L_R	W_R	Fr
LIT-40	1.93	1.60	0.33	0.83	0.005	0.016	0.04	0.00	2.46	1.56	64.11	0.02	10.55
LIT-40	2.50	1.96	0.54	0.78	0.005	0.016	0.07	0.00	2.46	1.56	36.16	0.04	5.09
LIT-40	3.28	2.37	0.91	0.72	0.005	0.016	0.10	0.00	2.46	1.56	25.20	0.06	3.39
LIT-40	4.20	2.78	1.42	0.66	0.005	0.016	0.13	0.00	2.46	1.56	19.63	0.08	2.64
LIT-40	5.20	3.14	2.05	0.60	0.005	0.016	0.15	0.00	2.46	1.56	16.54	0.10	2.27
LIT-40	5.87	3.37	2.50	0.57	0.005	0.016	0.16	0.00	2.46	1.56	15.10	0.10	2.10
LIT-40	6.70	3.67	3.02	0.55	0.005	0.016	0.18	0.00	2.46	1.56	13.60	0.12	1.92
LIT-40	7.38	3.89	3.49	0.53	0.005	0.016	0.19	0.00	2.46	1.56	12.73	0.12	1.83
LIT-40	7.97	4.05	3.91	0.51	0.005	0.016	0.20	0.00	2.46	1.56	12.16	0.13	1.77
LIT-40	1.82	1.52	0.31	0.83	0.010	0.016	0.03	0.00	2.46	1.56	81.20	0.02	14.63
LIT-40	2.30	1.84	0.46	0.80	0.010	0.016	0.06	0.00	2.46	1.56	42.73	0.04	6.27
LIT-40	3.55	2.43	1.12	0.69	0.010	0.016	0.10	0.00	2.46	1.56	23.91	0.07	3.26
LIT-40	4.54	2.86	1.68	0.63	0.010	0.016	0.13	0.00	2.46	1.56	18.77	0.08	2.57
LIT-40	5.73	3.29	2.44	0.57	0.010	0.016	0.16	0.00	2.46	1.56	15.60	0.10	2.18
LIT-40	6.45	3.58	2.87	0.56	0.010	0.016	0.18	0.00	2.46	1.56	14.05	0.11	1.98
LIT-40	7.48	3.89	3.59	0.52	0.010	0.016	0.19	0.00	2.46	1.56	12.73	0.12	1.84
LIT-40	8.20	4.05	4.14	0.49	0.010	0.016	0.20	0.00	2.46	1.56	12.16	0.13	1.80
LIT-40	8.56	4.28	4.28	0.50	0.010	0.016	0.22	0.00	2.46	1.56	11.43	0.14	1.67
LIT-40	9.03	4.22	4.81	0.47	0.010	0.016	0.21	0.00	2.46	1.56	11.62	0.14	1.76
LIT-40	2.00	1.70	0.30	0.85	0.020	0.016	0.05	0.00	2.46	1.56	50.80	0.03	7.57
LIT-40	2.98	2.32	0.66	0.78	0.020	0.016	0.09	0.00	2.46	1.56	26.11	0.06	3.41
LIT-40	3.68	2.63	1.05	0.71	0.020	0.016	0.12	0.00	2.46	1.56	21.33	0.07	2.80
LIT-40	4.41	2.95	1.47	0.67	0.020	0.016	0.14	0.00	2.46	1.56	18.02	0.09	2.38
LIT-40	5.08	3.19	1.88	0.63	0.020	0.016	0.15	0.00	2.46	1.56	16.20	0.10	2.17
LIT-40	5.97	3.49	2.48	0.58	0.020	0.016	0.17	0.00	2.46	1.56	14.48	0.11	1.99
LIT-40	7.09	3.80	3.29	0.54	0.020	0.016	0.19	0.00	2.46	1.56	13.10	0.12	1.87
LIT-40	8.03	4.10	3.93	0.51	0.020	0.016	0.20	0.00	2.46	1.56	12.01	0.13	1.75
LIT-40	8.53	4.20	4.33	0.49	0.020	0.016	0.21	0.00	2.46	1.56	11.66	0.14	1.72
LIT-40	1.77	1.64	0.13	0.93	0.030	0.016	0.04	0.00	2.46	1.56	59.53	0.03	9.05
LIT-40	2.54	2.11	0.43	0.83	0.030	0.016	0.08	0.00	2.46	1.56	30.94	0.05	4.06
LIT-40	3.19	2.69	0.50	0.84	0.030	0.016	0.12	0.00	2.46	1.56	20.51	0.08	2.46
LIT-40	4.18	3.06	1.12	0.73	0.030	0.016	0.14	0.00	2.46	1.56	17.11	0.09	2.14
LIT-40	5.26	3.46	1.80	0.66	0.030	0.016	0.17	0.00	2.46	1.56	14.64	0.11	1.90
LIT-40	6.00	3.70	2.30	0.62	0.030	0.016	0.18	0.00	2.46	1.56	13.51	0.12	1.80
LIT-40	6.79	3.93	2.86	0.58	0.030	0.016	0.20	0.00	2.46	1.56	12.59	0.13	1.72
LIT-40	7.56	4.15	3.41	0.55	0.030	0.016	0.21	0.00	2.46	1.56	11.84	0.13	1.66
LIT-40	8.36	4.36	4.01	0.52	0.030	0.016	0.22	0.00	2.46	1.56	11.23	0.14	1.61
LIT-40	9.19	4.53	4.66	0.49	0.030	0.016	0.23	0.00	2.46	1.56	10.75	0.15	1.58
LIT-40	2.84	2.34	0.50	0.83	0.050	0.016	0.10	0.00	2.46	1.56	25.50	0.06	3.21

Continued on next page

Table 5: Literature-Derived Performance Data for Drop-Type Inlets — Continued

ID-CODE	Q_A	Q_I	Q_O	Q_R	S_0	S_x	d_a	h_b	L_I	W_I	L_R	W_R	Fr
LIT-40	3.51	2.90	0.61	0.83	0.050	0.016	0.13	0.00	2.46	1.56	18.47	0.09	2.20
LIT-40	4.04	3.12	0.92	0.77	0.050	0.016	0.15	0.00	2.46	1.56	16.89	0.09	2.07
LIT-40	4.74	3.39	1.34	0.72	0.050	0.016	0.16	0.00	2.46	1.56	15.02	0.11	1.87
LIT-40	5.07	3.52	1.55	0.69	0.050	0.016	0.17	0.00	2.46	1.56	14.35	0.11	1.81
LIT-40	6.16	3.92	2.24	0.64	0.050	0.016	0.20	0.00	2.46	1.56	12.59	0.13	1.64
LIT-40	7.05	4.19	2.87	0.59	0.050	0.016	0.21	0.00	2.46	1.56	11.72	0.13	1.58
LIT-40	7.82	4.36	3.46	0.56	0.050	0.016	0.22	0.00	2.46	1.56	11.22	0.14	1.56
LIT-40	8.44	4.53	3.91	0.54	0.050	0.016	0.23	0.00	2.46	1.56	10.76	0.15	1.52
LIT-40	9.02	4.60	4.42	0.51	0.050	0.016	0.23	0.00	2.46	1.56	10.61	0.15	1.54
LIT-40	2.12	1.81	0.32	0.85	0.005	0.031	0.06	0.00	2.46	1.56	43.92	0.04	8.74
LIT-40	2.48	2.20	0.29	0.88	0.005	0.031	0.08	0.00	2.46	1.56	29.24	0.05	5.14
LIT-40	3.63	2.88	0.75	0.79	0.005	0.031	0.13	0.00	2.46	1.56	18.41	0.09	3.10
LIT-40	4.40	3.24	1.15	0.74	0.005	0.031	0.16	0.00	2.46	1.56	15.86	0.10	2.73
LIT-40	4.87	3.48	1.39	0.71	0.005	0.031	0.17	0.00	2.46	1.56	14.56	0.11	2.53
LIT-40	5.86	3.88	1.98	0.66	0.005	0.031	0.19	0.00	2.46	1.56	12.78	0.12	2.28
LIT-40	6.42	4.17	2.26	0.65	0.005	0.031	0.21	0.00	2.46	1.56	11.78	0.13	2.11
LIT-40	7.06	4.37	2.69	0.62	0.005	0.031	0.22	0.00	2.46	1.56	11.26	0.14	2.07
LIT-40	7.59	4.57	3.01	0.60	0.005	0.031	0.23	0.00	2.46	1.56	10.65	0.15	1.97
LIT-40	8.24	4.74	3.50	0.58	0.005	0.031	0.24	0.00	2.46	1.56	10.25	0.15	1.94
LIT-40	1.94	1.69	0.25	0.87	0.010	0.031	0.04	0.00	2.46	1.56	57.25	0.03	12.44
LIT-40	2.59	2.24	0.36	0.86	0.010	0.031	0.09	0.00	2.46	1.56	27.90	0.06	4.89
LIT-40	3.46	2.70	0.76	0.78	0.010	0.031	0.12	0.00	2.46	1.56	20.37	0.08	3.52
LIT-40	4.09	3.02	1.07	0.74	0.010	0.031	0.14	0.00	2.46	1.56	17.41	0.09	3.03
LIT-40	5.20	3.51	1.69	0.68	0.010	0.031	0.17	0.00	2.46	1.56	14.31	0.11	2.54
LIT-40	5.92	3.78	2.14	0.64	0.010	0.031	0.19	0.00	2.46	1.56	13.17	0.12	2.40
LIT-40	6.73	4.03	2.70	0.60	0.010	0.031	0.20	0.00	2.46	1.56	12.29	0.13	2.30
LIT-40	7.40	4.22	3.18	0.57	0.010	0.031	0.21	0.00	2.46	1.56	11.61	0.14	2.22
LIT-40	7.89	4.37	3.51	0.55	0.010	0.031	0.22	0.00	2.46	1.56	11.18	0.14	2.16
LIT-40	8.52	4.55	3.97	0.53	0.010	0.031	0.23	0.00	2.46	1.56	10.71	0.15	2.11
LIT-40	9.08	4.67	4.41	0.51	0.010	0.031	0.24	0.00	2.46	1.56	10.42	0.15	2.09
LIT-40	2.08	1.76	0.32	0.84	0.020	0.031	0.05	0.00	2.46	1.56	47.27	0.03	9.67
LIT-40	2.60	2.27	0.32	0.88	0.020	0.031	0.09	0.00	2.46	1.56	26.98	0.06	4.65
LIT-40	4.09	3.04	1.05	0.74	0.020	0.031	0.14	0.00	2.46	1.56	17.54	0.09	3.06
LIT-40	5.15	3.43	1.71	0.67	0.020	0.031	0.17	0.00	2.46	1.56	14.71	0.11	2.64
LIT-40	5.92	3.74	2.18	0.63	0.020	0.031	0.18	0.00	2.46	1.56	13.34	0.12	2.44
LIT-40	6.50	3.94	2.57	0.61	0.020	0.031	0.20	0.00	2.46	1.56	12.55	0.13	2.34
LIT-40	7.30	4.20	3.11	0.57	0.020	0.031	0.21	0.00	2.46	1.56	11.69	0.14	2.23
LIT-40	7.83	4.37	3.46	0.56	0.020	0.031	0.22	0.00	2.46	1.56	11.19	0.14	2.16
LIT-40	8.38	4.55	3.82	0.54	0.020	0.031	0.23	0.00	2.46	1.56	10.70	0.15	2.09

Continued on next page

Table 5: Literature-Derived Performance Data for Drop-Type Inlets — Continued

ID-CODE	Q_A	Q_I	Q_O	Q_R	S_0	S_x	d_a	h_b	L_I	W_I	L_R	W_R	Fr
LIT-40	9.09	4.76	4.33	0.52	0.020	0.031	0.24	0.00	2.46	1.56	10.22	0.15	2.03
LIT-40	1.81	1.63	0.18	0.90	0.030	0.031	0.04	0.00	2.46	1.56	61.36	0.03	13.31
LIT-40	2.87	2.31	0.56	0.80	0.030	0.031	0.09	0.00	2.46	1.56	26.26	0.06	4.70
LIT-40	3.78	3.10	0.67	0.82	0.030	0.031	0.15	0.00	2.46	1.56	16.76	0.09	2.75
LIT-40	4.49	3.32	1.17	0.74	0.030	0.031	0.16	0.00	2.46	1.56	15.40	0.10	2.64
LIT-40	5.48	3.70	1.78	0.68	0.030	0.031	0.18	0.00	2.46	1.56	13.51	0.12	2.40
LIT-40	6.55	4.10	2.46	0.62	0.030	0.031	0.20	0.00	2.46	1.56	12.01	0.13	2.20
LIT-40	7.29	4.31	2.98	0.59	0.030	0.031	0.22	0.00	2.46	1.56	11.42	0.14	2.15
LIT-40	7.77	4.43	3.34	0.57	0.030	0.031	0.22	0.00	2.46	1.56	11.01	0.14	2.10
LIT-40	8.28	4.58	3.70	0.55	0.030	0.031	0.23	0.00	2.46	1.56	10.63	0.15	2.06
LIT-40	8.99	4.79	4.20	0.53	0.030	0.031	0.24	0.00	2.46	1.56	10.15	0.16	2.00
LIT-40	1.73	1.64	0.09	0.95	0.050	0.031	0.04	0.00	2.46	1.56	58.89	0.03	12.26
LIT-40	3.07	2.54	0.53	0.83	0.050	0.031	0.11	0.00	2.46	1.56	22.10	0.07	3.75
LIT-40	3.85	3.12	0.73	0.81	0.050	0.031	0.15	0.00	2.46	1.56	16.61	0.10	2.74
LIT-40	4.50	3.47	1.03	0.77	0.050	0.031	0.17	0.00	2.46	1.56	14.60	0.11	2.44
LIT-40	5.15	3.71	1.44	0.72	0.050	0.031	0.18	0.00	2.46	1.56	13.51	0.12	2.32
LIT-40	6.00	4.09	1.91	0.68	0.050	0.031	0.20	0.00	2.46	1.56	12.02	0.13	2.10
LIT-40	7.13	4.55	2.57	0.64	0.050	0.031	0.23	0.00	2.46	1.56	10.70	0.15	1.92
LIT-40	7.66	4.66	3.00	0.61	0.050	0.031	0.24	0.00	2.46	1.56	10.45	0.15	1.93
LIT-40	8.25	4.83	3.42	0.59	0.050	0.031	0.24	0.00	2.46	1.56	10.06	0.16	1.89
LIT-40	9.23	5.24	3.98	0.57	0.050	0.031	0.27	0.00	2.46	1.56	9.25	0.17	1.76
LIT-40	10.05	5.43	4.61	0.54	0.050	0.031	0.28	0.00	2.46	1.56	8.94	0.18	1.74
LIT-41	2.16	1.63	0.54	0.75	0.005	0.016	0.03	0.00	4.92	2.49	143.49	0.01	13.24
LIT-41	2.32	1.93	0.39	0.83	0.005	0.016	0.05	0.00	4.92	2.49	90.09	0.02	6.81
LIT-41	2.76	2.17	0.59	0.79	0.005	0.016	0.07	0.00	4.92	2.49	68.94	0.03	4.98
LIT-41	3.80	2.71	1.09	0.71	0.005	0.016	0.10	0.00	4.92	2.49	47.09	0.04	3.30
LIT-41	4.06	2.79	1.27	0.69	0.005	0.016	0.11	0.00	4.92	2.49	45.35	0.04	3.22
LIT-41	4.78	2.99	1.78	0.63	0.005	0.016	0.12	0.00	4.92	2.49	41.12	0.05	3.02
LIT-41	5.45	3.17	2.28	0.58	0.005	0.016	0.13	0.00	4.92	2.49	38.61	0.05	2.93
LIT-41	5.92	3.25	2.67	0.55	0.005	0.016	0.13	0.00	4.92	2.49	36.88	0.05	2.85
LIT-41	6.46	3.40	3.06	0.53	0.005	0.016	0.14	0.00	4.92	2.49	34.88	0.06	2.74
LIT-41	7.01	3.54	3.47	0.51	0.005	0.016	0.15	0.00	4.92	2.49	33.13	0.06	2.64
LIT-41	1.97	1.73	0.25	0.87	0.010	0.016	0.04	0.00	4.92	2.49	119.67	0.02	9.63
LIT-41	2.64	2.12	0.52	0.80	0.010	0.016	0.07	0.00	4.92	2.49	72.45	0.03	5.24
LIT-41	3.37	2.37	1.00	0.70	0.010	0.016	0.08	0.00	4.92	2.49	58.37	0.03	4.29
LIT-41	3.98	2.52	1.47	0.63	0.010	0.016	0.09	0.00	4.92	2.49	54.05	0.04	4.15
LIT-41	4.72	2.62	2.10	0.55	0.010	0.016	0.10	0.00	4.92	2.49	49.96	0.04	4.02
LIT-41	5.27	2.69	2.57	0.51	0.010	0.016	0.10	0.00	4.92	2.49	47.85	0.04	3.98
LIT-41	2.28	1.73	0.54	0.76	0.020	0.016	0.04	0.00	4.92	2.49	118.70	0.02	10.21

Continued on next page

Table 5: Literature-Derived Performance Data for Drop-Type Inlets — Continued

ID-CODE	Q_A	Q_I	Q_O	Q_R	S_0	S_x	d_a	h_b	L_I	W_I	L_R	W_R	Fr
LIT-41	2.42	1.89	0.53	0.78	0.020	0.016	0.05	0.00	4.92	2.49	93.11	0.02	7.31
LIT-41	2.90	1.98	0.92	0.68	0.020	0.016	0.06	0.00	4.92	2.49	83.30	0.02	6.78
LIT-41	3.49	2.07	1.42	0.59	0.020	0.016	0.06	0.00	4.92	2.49	83.30	0.02	7.43
LIT-41	3.93	2.13	1.79	0.54	0.020	0.016	0.07	0.00	4.92	2.49	71.37	0.03	6.26
LIT-41	4.55	2.22	2.33	0.49	0.020	0.016	0.07	0.00	4.92	2.49	67.57	0.03	6.20
LIT-41	5.08	2.26	2.82	0.44	0.020	0.016	0.08	0.00	4.92	2.49	63.82	0.03	6.02
LIT-41	1.86	1.54	0.32	0.83	0.030	0.016	0.03	0.00	4.92	2.49	186.45	0.01	18.17
LIT-41	2.02	1.62	0.39	0.80	0.030	0.016	0.03	0.00	4.92	2.49	150.15	0.01	13.68
LIT-41	2.68	1.83	0.85	0.68	0.030	0.016	0.05	0.00	4.92	2.49	101.54	0.02	8.77
LIT-41	3.18	1.86	1.32	0.58	0.030	0.016	0.05	0.00	4.92	2.49	97.23	0.02	8.95
LIT-41	3.76	1.94	1.82	0.52	0.030	0.016	0.05	0.00	4.92	2.49	90.09	0.02	8.68
LIT-41	4.52	2.06	2.47	0.45	0.030	0.016	0.05	0.00	4.92	2.49	90.09	0.02	9.52
LIT-41	3.73	1.72	2.00	0.46	0.050	0.016	0.04	0.00	4.92	2.49	120.21	0.02	13.32
LIT-41	2.12	1.81	0.32	0.85	0.005	0.031	0.05	0.00	4.92	2.49	105.09	0.02	11.44
LIT-41	2.85	2.36	0.49	0.83	0.005	0.031	0.08	0.00	4.92	2.49	58.48	0.03	5.50
LIT-41	3.64	2.67	0.97	0.73	0.005	0.031	0.10	0.00	4.92	2.49	48.28	0.04	4.66
LIT-41	4.66	3.04	1.61	0.65	0.005	0.031	0.12	0.00	4.92	2.49	40.15	0.05	4.00
LIT-41	4.91	3.30	1.62	0.67	0.005	0.031	0.14	0.00	4.92	2.49	36.24	0.05	3.52
LIT-41	5.68	3.39	2.30	0.60	0.005	0.031	0.14	0.00	4.92	2.49	35.08	0.06	3.61
LIT-41	6.15	3.48	2.67	0.57	0.005	0.031	0.15	0.00	4.92	2.49	33.92	0.06	3.57
LIT-41	7.04	3.60	3.44	0.51	0.005	0.031	0.15	0.00	4.92	2.49	32.54	0.06	3.59
LIT-41	2.04	1.79	0.26	0.87	0.010	0.031	0.07	0.00	4.92	2.49	73.61	0.03	6.58
LIT-41	2.43	2.09	0.34	0.86	0.010	0.031	0.07	0.00	4.92	2.49	72.15	0.03	6.96
LIT-41	3.18	2.44	0.74	0.77	0.010	0.031	0.09	0.00	4.92	2.49	57.25	0.03	5.63
LIT-41	3.63	2.56	1.07	0.70	0.010	0.031	0.09	0.00	4.92	2.49	51.87	0.04	5.18
LIT-41	4.35	2.66	1.70	0.61	0.010	0.031	0.10	0.00	4.92	2.49	48.74	0.04	5.17
LIT-41	4.66	2.81	1.85	0.60	0.010	0.031	0.11	0.00	4.92	2.49	44.94	0.04	4.74
LIT-41	5.92	2.91	3.01	0.49	0.010	0.031	0.11	0.00	4.92	2.49	42.88	0.05	4.98
LIT-41	6.69	2.99	3.70	0.45	0.010	0.031	0.12	0.00	4.92	2.49	41.17	0.05	4.98
LIT-41	2.65	1.93	0.72	0.73	0.020	0.031	0.06	0.00	4.92	2.49	88.57	0.02	9.88
LIT-41	3.38	2.08	1.31	0.61	0.020	0.031	0.06	0.00	4.92	2.49	76.34	0.03	8.94
LIT-41	4.44	2.17	2.28	0.49	0.020	0.031	0.07	0.00	4.92	2.49	69.08	0.03	8.82
LIT-41	5.10	2.31	2.79	0.45	0.020	0.031	0.08	0.00	4.92	2.49	61.44	0.03	7.92
LIT-41	5.68	2.38	3.31	0.42	0.020	0.031	0.08	0.00	4.92	2.49	58.31	0.03	7.73
LIT-41	3.59	1.90	1.69	0.53	0.030	0.031	0.05	0.00	4.92	2.49	90.91	0.02	11.97
LIT-41	4.17	2.03	2.14	0.49	0.030	0.031	0.06	0.00	4.92	2.49	78.52	0.03	10.36
LIT-41	5.11	2.16	2.95	0.42	0.030	0.031	0.07	0.00	4.92	2.49	69.42	0.03	9.53
LIT-42	2.25	1.97	0.27	0.88	0.005	0.016	0.05	0.00	9.84	2.49	204.19	0.02	8.10
LIT-42	2.67	2.39	0.28	0.89	0.005	0.016	0.07	0.00	9.84	2.49	144.70	0.03	5.26

Continued on next page

Table 5: Literature-Derived Performance Data for Drop-Type Inlets — Continued

ID-CODE	Q_A	Q_I	Q_O	Q_R	S_0	S_x	d_a	h_b	L_I	W_I	L_R	W_R	Fr
LIT-42	3.11	2.72	0.39	0.88	0.005	0.016	0.08	0.00	9.84	2.49	117.81	0.03	4.17
LIT-42	3.41	2.92	0.49	0.86	0.005	0.016	0.09	0.00	9.84	2.49	108.11	0.04	3.84
LIT-42	4.26	3.37	0.89	0.79	0.005	0.016	0.11	0.00	9.84	2.49	90.09	0.04	3.27
LIT-42	5.41	3.92	1.48	0.73	0.005	0.016	0.13	0.00	9.84	2.49	75.26	0.05	2.81
LIT-42	6.52	4.43	2.09	0.68	0.005	0.016	0.15	0.00	9.84	2.49	65.57	0.06	2.51
LIT-42	7.49	4.82	2.67	0.64	0.005	0.016	0.16	0.00	9.84	2.49	60.39	0.07	2.38
LIT-42	8.41	5.19	3.22	0.62	0.005	0.016	0.17	0.00	9.84	2.49	56.28	0.07	2.27
LIT-42	2.72	2.25	0.47	0.83	0.010	0.016	0.06	0.00	9.84	2.49	159.46	0.02	6.14
LIT-42	3.04	2.63	0.40	0.87	0.010	0.016	0.08	0.00	9.84	2.49	122.84	0.03	4.39
LIT-42	3.66	2.94	0.71	0.80	0.010	0.016	0.09	0.00	9.84	2.49	106.14	0.04	3.87
LIT-42	4.54	3.43	1.11	0.76	0.010	0.016	0.11	0.00	9.84	2.49	87.58	0.05	3.23
LIT-42	4.97	3.64	1.33	0.73	0.010	0.016	0.12	0.00	9.84	2.49	81.62	0.05	3.04
LIT-42	5.66	3.95	1.71	0.70	0.010	0.016	0.13	0.00	9.84	2.49	74.55	0.05	2.83
LIT-42	6.53	4.32	2.20	0.66	0.010	0.016	0.15	0.00	9.84	2.49	67.65	0.06	2.63
LIT-42	7.01	4.48	2.53	0.64	0.010	0.016	0.15	0.00	9.84	2.49	65.25	0.06	2.58
LIT-42	7.83	4.82	3.01	0.62	0.010	0.016	0.16	0.00	9.84	2.49	60.58	0.07	2.44
LIT-42	2.11	1.80	0.31	0.85	0.020	0.016	0.04	0.00	9.84	2.49	270.27	0.01	11.95
LIT-42	2.58	2.22	0.36	0.86	0.020	0.016	0.06	0.00	9.84	2.49	163.26	0.02	6.20
LIT-42	3.36	2.87	0.50	0.85	0.020	0.016	0.09	0.00	9.84	2.49	110.03	0.04	3.92
LIT-42	3.75	3.02	0.72	0.81	0.020	0.016	0.10	0.00	9.84	2.49	102.67	0.04	3.73
LIT-42	4.49	3.46	1.03	0.77	0.020	0.016	0.11	0.00	9.84	2.49	86.78	0.05	3.17
LIT-42	5.04	3.70	1.34	0.73	0.020	0.016	0.12	0.00	9.84	2.49	79.97	0.05	2.97
LIT-42	5.92	4.06	1.86	0.69	0.020	0.016	0.14	0.00	9.84	2.49	72.46	0.05	2.78
LIT-42	6.46	4.29	2.16	0.66	0.020	0.016	0.14	0.00	9.84	2.49	68.23	0.06	2.65
LIT-42	7.61	4.75	2.86	0.62	0.020	0.016	0.16	0.00	9.84	2.49	61.32	0.06	2.45
LIT-42	8.32	5.01	3.31	0.60	0.020	0.016	0.17	0.00	9.84	2.49	58.27	0.07	2.37
LIT-42	1.98	1.77	0.20	0.90	0.030	0.016	0.04	0.00	9.84	2.49	270.27	0.01	11.56
LIT-42	2.88	2.37	0.52	0.82	0.030	0.016	0.07	0.00	9.84	2.49	145.05	0.03	5.49
LIT-42	3.34	2.90	0.44	0.87	0.030	0.016	0.09	0.00	9.84	2.49	108.23	0.04	3.81
LIT-42	3.87	3.21	0.66	0.83	0.030	0.016	0.10	0.00	9.84	2.49	94.76	0.04	3.36
LIT-42	4.63	3.61	1.02	0.78	0.030	0.016	0.12	0.00	9.84	2.49	82.50	0.05	2.98
LIT-42	5.00	3.78	1.22	0.76	0.030	0.016	0.13	0.00	9.84	2.49	78.44	0.05	2.87
LIT-42	5.74	4.13	1.61	0.72	0.030	0.016	0.14	0.00	9.84	2.49	71.14	0.06	2.66
LIT-42	6.35	4.39	1.96	0.69	0.030	0.016	0.15	0.00	9.84	2.49	66.73	0.06	2.54
LIT-42	7.03	4.59	2.43	0.65	0.030	0.016	0.15	0.00	9.84	2.49	63.63	0.06	2.49
LIT-42	7.53	4.74	2.79	0.63	0.030	0.016	0.16	0.00	9.84	2.49	61.61	0.06	2.46
LIT-42	8.20	4.89	3.31	0.60	0.030	0.016	0.16	0.00	9.84	2.49	60.06	0.07	2.47
LIT-42	8.61	5.01	3.60	0.58	0.030	0.016	0.17	0.00	9.84	2.49	58.38	0.07	2.42
LIT-42	9.77	5.08	4.69	0.52	0.030	0.016	0.17	0.00	9.84	2.49	57.54	0.07	2.53

Continued on next page

Table 5: Literature-Derived Performance Data for Drop-Type Inlets — Continued

ID-CODE	Q_A	Q_I	Q_O	Q_R	S_0	S_x	d_a	h_b	L_I	W_I	L_R	W_R	Fr
LIT-42	10.22	5.15	5.07	0.50	0.030	0.016	0.17	0.00	9.84	2.49	56.75	0.07	2.53
LIT-42	1.89	1.79	0.10	0.95	0.050	0.016	0.04	0.00	9.84	2.49	261.76	0.02	10.76
LIT-42	2.92	2.61	0.31	0.89	0.050	0.016	0.08	0.00	9.84	2.49	126.10	0.03	4.48
LIT-42	3.39	2.86	0.53	0.84	0.050	0.016	0.09	0.00	9.84	2.49	110.55	0.04	3.96
LIT-42	3.66	3.20	0.46	0.88	0.050	0.016	0.10	0.00	9.84	2.49	94.95	0.04	3.28
LIT-42	4.48	3.64	0.84	0.81	0.050	0.016	0.12	0.00	9.84	2.49	81.70	0.05	2.89
LIT-42	5.00	3.86	1.14	0.77	0.050	0.016	0.13	0.00	9.84	2.49	77.22	0.05	2.81
LIT-42	5.53	4.02	1.51	0.73	0.050	0.016	0.13	0.00	9.84	2.49	73.11	0.05	2.72
LIT-42	6.31	4.16	2.16	0.66	0.050	0.016	0.14	0.00	9.84	2.49	70.66	0.06	2.76
LIT-42	6.70	4.28	2.42	0.64	0.050	0.016	0.14	0.00	9.84	2.49	68.45	0.06	2.71
LIT-42	7.02	4.32	2.70	0.62	0.050	0.016	0.15	0.00	9.84	2.49	67.79	0.06	2.74
LIT-42	7.64	4.42	3.23	0.58	0.050	0.016	0.15	0.00	9.84	2.49	66.31	0.06	2.76
LIT-42	8.14	4.53	3.60	0.56	0.050	0.016	0.15	0.00	9.84	2.49	64.54	0.06	2.74
LIT-42	2.73	2.62	0.11	0.96	0.005	0.031	0.08	0.00	9.84	2.49	119.52	0.03	5.56
LIT-42	3.59	3.19	0.40	0.89	0.005	0.031	0.10	0.00	9.84	2.49	95.69	0.04	4.57
LIT-42	3.81	3.32	0.49	0.87	0.005	0.031	0.11	0.00	9.84	2.49	91.08	0.04	4.37
LIT-42	4.29	3.86	0.43	0.90	0.005	0.031	0.13	0.00	9.84	2.49	76.34	0.05	3.56
LIT-42	5.39	4.53	0.87	0.84	0.005	0.031	0.15	0.00	9.84	2.49	64.50	0.06	3.10
LIT-42	6.16	4.89	1.27	0.79	0.005	0.031	0.16	0.00	9.84	2.49	60.06	0.07	2.98
LIT-42	6.56	5.08	1.48	0.77	0.005	0.031	0.17	0.00	9.84	2.49	57.59	0.07	2.88
LIT-42	7.14	5.39	1.75	0.76	0.005	0.031	0.18	0.00	9.84	2.49	54.23	0.07	2.75
LIT-42	7.68	5.66	2.02	0.74	0.005	0.031	0.19	0.00	9.84	2.49	51.83	0.08	2.66
LIT-42	8.32	5.91	2.41	0.71	0.005	0.031	0.20	0.00	9.84	2.49	49.71	0.08	2.60
LIT-42	2.61	2.40	0.21	0.92	0.010	0.031	0.07	0.00	9.84	2.49	141.98	0.03	7.04
LIT-42	3.31	2.82	0.49	0.85	0.010	0.031	0.09	0.00	9.84	2.49	114.50	0.03	5.74
LIT-42	3.70	3.29	0.41	0.89	0.010	0.031	0.11	0.00	9.84	2.49	91.73	0.04	4.35
LIT-42	4.41	3.74	0.67	0.85	0.010	0.031	0.12	0.00	9.84	2.49	79.07	0.05	3.80
LIT-42	5.17	4.16	1.01	0.80	0.010	0.031	0.14	0.00	9.84	2.49	70.48	0.06	3.46
LIT-42	5.71	4.47	1.24	0.78	0.010	0.031	0.15	0.00	9.84	2.49	65.48	0.06	3.26
LIT-42	6.22	4.74	1.48	0.76	0.010	0.031	0.16	0.00	9.84	2.49	61.52	0.06	3.10
LIT-42	6.81	5.05	1.76	0.74	0.010	0.031	0.17	0.00	9.84	2.49	57.89	0.07	2.96
LIT-42	7.31	5.27	2.05	0.72	0.010	0.031	0.18	0.00	9.84	2.49	55.49	0.07	2.88
LIT-42	7.72	5.43	2.29	0.70	0.010	0.031	0.18	0.00	9.84	2.49	54.05	0.07	2.84
LIT-42	8.24	5.62	2.61	0.68	0.010	0.031	0.19	0.00	9.84	2.49	52.17	0.08	2.79
LIT-42	8.76	5.82	2.94	0.66	0.010	0.031	0.20	0.00	9.84	2.49	50.44	0.08	2.73
LIT-42	9.52	6.08	3.44	0.64	0.010	0.031	0.20	0.00	9.84	2.49	48.50	0.08	2.68
LIT-42	2.55	2.27	0.28	0.89	0.020	0.031	0.06	0.00	9.84	2.49	156.90	0.03	8.08
LIT-42	3.04	2.77	0.27	0.91	0.020	0.031	0.08	0.00	9.84	2.49	116.96	0.03	5.68
LIT-42	3.63	3.17	0.47	0.87	0.020	0.031	0.10	0.00	9.84	2.49	96.40	0.04	4.65

Continued on next page

Table 5: Literature-Derived Performance Data for Drop-Type Inlets — Continued

ID-CODE	Q_A	Q_I	Q_O	Q_R	S_0	S_x	d_a	h_b	L_I	W_I	L_R	W_R	Fr
LIT-42	4.22	3.46	0.76	0.82	0.020	0.031	0.11	0.00	9.84	2.49	86.81	0.05	4.28
LIT-42	5.01	3.90	1.11	0.78	0.020	0.031	0.13	0.00	9.84	2.49	76.34	0.05	3.85
LIT-42	6.22	4.50	1.72	0.72	0.020	0.031	0.15	0.00	9.84	2.49	65.43	0.06	3.40
LIT-42	6.76	4.74	2.02	0.70	0.020	0.031	0.16	0.00	9.84	2.49	61.54	0.06	3.23
LIT-42	7.29	4.93	2.35	0.68	0.020	0.031	0.17	0.00	9.84	2.49	59.24	0.07	3.17
LIT-42	8.09	5.20	2.89	0.64	0.020	0.031	0.18	0.00	9.84	2.49	56.21	0.07	3.09
LIT-42	8.60	5.31	3.29	0.62	0.020	0.031	0.18	0.00	9.84	2.49	55.02	0.07	3.08
LIT-42	9.48	5.52	3.96	0.58	0.020	0.031	0.19	0.00	9.84	2.49	53.07	0.07	3.07
LIT-42	10.78	5.71	5.07	0.53	0.020	0.031	0.19	0.00	9.84	2.49	51.38	0.08	3.11
LIT-42	2.74	2.44	0.30	0.89	0.030	0.031	0.07	0.00	9.84	2.49	139.12	0.03	7.00
LIT-42	3.69	3.11	0.58	0.84	0.030	0.031	0.10	0.00	9.84	2.49	98.34	0.04	4.83
LIT-42	4.13	3.58	0.55	0.87	0.030	0.031	0.12	0.00	9.84	2.49	83.22	0.05	3.97
LIT-42	4.67	3.86	0.80	0.83	0.030	0.031	0.13	0.00	9.84	2.49	77.22	0.05	3.78
LIT-42	5.23	4.20	1.03	0.80	0.030	0.031	0.14	0.00	9.84	2.49	69.72	0.06	3.43
LIT-42	5.98	4.43	1.55	0.74	0.030	0.031	0.15	0.00	9.84	2.49	66.06	0.06	3.38
LIT-42	6.67	4.61	2.06	0.69	0.030	0.031	0.16	0.00	9.84	2.49	63.47	0.06	3.36
LIT-42	7.10	4.71	2.40	0.66	0.030	0.031	0.16	0.00	9.84	2.49	62.04	0.06	3.35
LIT-42	7.76	4.82	2.94	0.62	0.030	0.031	0.16	0.00	9.84	2.49	60.54	0.07	3.38
LIT-42	8.49	4.97	3.52	0.59	0.030	0.031	0.17	0.00	9.84	2.49	58.82	0.07	3.39
LIT-42	9.21	5.08	4.12	0.55	0.030	0.031	0.17	0.00	9.84	2.49	57.49	0.07	3.41
LIT-42	10.46	5.39	5.07	0.52	0.030	0.031	0.18	0.00	9.84	2.49	54.24	0.07	3.33
LIT-42	2.85	2.59	0.26	0.91	0.050	0.031	0.08	0.00	9.84	2.49	127.52	0.03	6.26
LIT-42	3.60	3.08	0.53	0.85	0.050	0.031	0.10	0.00	9.84	2.49	99.85	0.04	4.88
LIT-42	4.04	3.52	0.51	0.87	0.050	0.031	0.12	0.00	9.84	2.49	84.73	0.05	4.04
LIT-42	4.86	3.73	1.12	0.77	0.050	0.031	0.12	0.00	9.84	2.49	79.45	0.05	4.02
LIT-42	5.55	3.89	1.65	0.70	0.050	0.031	0.13	0.00	9.84	2.49	75.88	0.05	4.01
LIT-42	6.16	4.05	2.11	0.66	0.050	0.031	0.14	0.00	9.84	2.49	72.64	0.05	3.96
LIT-42	6.70	4.19	2.51	0.63	0.050	0.031	0.14	0.00	9.84	2.49	70.06	0.06	3.91
LIT-42	7.58	4.39	3.19	0.58	0.050	0.031	0.15	0.00	9.84	2.49	66.67	0.06	3.86
LIT-42	8.34	4.64	3.70	0.56	0.050	0.031	0.16	0.00	9.84	2.49	62.99	0.06	3.72
LIT-42	9.54	4.89	4.65	0.51	0.050	0.031	0.16	0.00	9.84	2.49	60.06	0.07	3.70
LIT-43	2.38	2.41	-0.03	1.01	0.005	0.016	0.06	0.00	14.76	2.49	250.93	0.02	6.18
LIT-43	2.83	2.76	0.06	0.98	0.005	0.016	0.07	0.00	14.76	2.49	204.48	0.03	4.95
LIT-43	3.17	3.01	0.16	0.95	0.005	0.016	0.08	0.00	14.76	2.49	182.84	0.03	4.43
LIT-43	3.54	3.29	0.25	0.93	0.005	0.016	0.09	0.00	14.76	2.49	164.05	0.04	3.98
LIT-43	3.93	3.67	0.26	0.93	0.005	0.016	0.10	0.00	14.76	2.49	144.22	0.04	3.46
LIT-43	4.73	4.28	0.44	0.91	0.005	0.016	0.12	0.00	14.76	2.49	122.04	0.05	2.95
LIT-43	5.32	4.66	0.66	0.88	0.005	0.016	0.13	0.00	14.76	2.49	112.37	0.05	2.77
LIT-43	6.45	5.34	1.11	0.83	0.005	0.016	0.15	0.00	14.76	2.49	98.35	0.06	2.50

Continued on next page

Table 5: Literature-Derived Performance Data for Drop-Type Inlets — Continued

ID-CODE	Q_A	Q_I	Q_O	Q_R	S_0	S_x	d_a	h_b	L_I	W_I	L_R	W_R	Fr
LIT-43	7.45	5.91	1.54	0.79	0.005	0.016	0.16	0.00	14.76	2.49	90.09	0.07	2.35
LIT-43	8.21	6.41	1.80	0.78	0.005	0.016	0.18	0.00	14.76	2.49	82.94	0.07	2.18
LIT-43	1.92	1.93	-0.01	1.00	0.010	0.016	0.04	0.00	14.76	2.49	379.36	0.02	10.32
LIT-43	2.34	2.31	0.02	0.99	0.010	0.016	0.05	0.00	14.76	2.49	270.27	0.02	6.85
LIT-43	2.46	2.37	0.09	0.96	0.010	0.016	0.06	0.00	14.76	2.49	258.05	0.02	6.55
LIT-43	3.17	2.89	0.28	0.91	0.010	0.016	0.08	0.00	14.76	2.49	191.42	0.03	4.75
LIT-43	3.56	3.15	0.41	0.89	0.010	0.016	0.09	0.00	14.76	2.49	172.07	0.03	4.29
LIT-43	4.46	3.97	0.49	0.89	0.010	0.016	0.11	0.00	14.76	2.49	132.60	0.04	3.25
LIT-43	4.82	4.09	0.73	0.85	0.010	0.016	0.11	0.00	14.76	2.49	128.54	0.05	3.22
LIT-43	5.74	4.63	1.11	0.81	0.010	0.016	0.13	0.00	14.76	2.49	113.12	0.05	2.90
LIT-43	6.47	5.00	1.47	0.77	0.010	0.016	0.14	0.00	14.76	2.49	104.52	0.06	2.74
LIT-43	7.24	5.39	1.85	0.74	0.010	0.016	0.15	0.00	14.76	2.49	97.50	0.06	2.61
LIT-43	8.44	5.83	2.61	0.69	0.010	0.016	0.16	0.00	14.76	2.49	90.53	0.07	2.52
LIT-43	9.01	6.08	2.93	0.68	0.010	0.016	0.17	0.00	14.76	2.49	87.17	0.07	2.46
LIT-43	9.47	6.25	3.22	0.66	0.010	0.016	0.17	0.00	14.76	2.49	85.08	0.07	2.43
LIT-43	1.90	1.87	0.03	0.98	0.020	0.016	0.04	0.00	14.76	2.49	407.58	0.01	11.43
LIT-43	2.14	2.07	0.07	0.97	0.020	0.016	0.04	0.00	14.76	2.49	328.89	0.02	8.79
LIT-43	2.46	2.31	0.15	0.94	0.020	0.016	0.06	0.00	14.76	2.49	264.40	0.02	6.79
LIT-43	3.18	2.79	0.40	0.88	0.020	0.016	0.07	0.00	14.76	2.49	202.22	0.03	5.17
LIT-43	3.96	3.55	0.41	0.90	0.020	0.016	0.10	0.00	14.76	2.49	149.27	0.04	3.66
LIT-43	4.44	3.80	0.65	0.85	0.020	0.016	0.11	0.00	14.76	2.49	139.33	0.04	3.49
LIT-43	5.00	4.12	0.88	0.82	0.020	0.016	0.12	0.00	14.76	2.49	127.41	0.05	3.24
LIT-43	5.74	4.53	1.21	0.79	0.020	0.016	0.13	0.00	14.76	2.49	114.87	0.05	2.97
LIT-43	6.58	4.94	1.64	0.75	0.020	0.016	0.14	0.00	14.76	2.49	105.88	0.06	2.82
LIT-43	7.13	5.19	1.93	0.73	0.020	0.016	0.15	0.00	14.76	2.49	101.35	0.06	2.74
LIT-43	7.75	5.51	2.24	0.71	0.020	0.016	0.15	0.00	14.76	2.49	95.48	0.06	2.62
LIT-43	8.66	5.88	2.78	0.68	0.020	0.016	0.16	0.00	14.76	2.49	90.09	0.07	2.53
LIT-43	2.16	2.06	0.11	0.95	0.030	0.016	0.04	0.00	14.76	2.49	343.51	0.02	9.43
LIT-43	2.68	2.56	0.12	0.95	0.030	0.016	0.06	0.00	14.76	2.49	227.81	0.03	5.67
LIT-43	3.48	3.05	0.43	0.88	0.030	0.016	0.08	0.00	14.76	2.49	180.69	0.03	4.57
LIT-43	3.70	3.40	0.30	0.92	0.030	0.016	0.09	0.00	14.76	2.49	157.57	0.04	3.83
LIT-43	4.34	3.82	0.52	0.88	0.030	0.016	0.11	0.00	14.76	2.49	137.40	0.04	3.38
LIT-43	4.78	4.08	0.71	0.85	0.030	0.016	0.11	0.00	14.76	2.49	128.93	0.05	3.23
LIT-43	5.60	4.53	1.07	0.81	0.030	0.016	0.13	0.00	14.76	2.49	114.85	0.05	2.93
LIT-43	6.14	4.82	1.32	0.79	0.030	0.016	0.14	0.00	14.76	2.49	108.52	0.05	2.82
LIT-43	6.43	4.97	1.46	0.77	0.030	0.016	0.14	0.00	14.76	2.49	105.54	0.06	2.77
LIT-43	6.64	5.08	1.56	0.76	0.030	0.016	0.14	0.00	14.76	2.49	103.22	0.06	2.72
LIT-43	7.52	5.38	2.15	0.71	0.030	0.016	0.15	0.00	14.76	2.49	97.72	0.06	2.67
LIT-43	8.40	5.82	2.58	0.69	0.030	0.016	0.16	0.00	14.76	2.49	90.78	0.07	2.52

Continued on next page

Table 5: Literature-Derived Performance Data for Drop-Type Inlets — Continued

ID-CODE	Q_A	Q_I	Q_O	Q_R	S_0	S_x	d_a	h_b	L_I	W_I	L_R	W_R	Fr
LIT-43	9.42	6.24	3.18	0.66	0.030	0.016	0.17	0.00	14.76	2.49	85.22	0.07	2.43
LIT-43	2.17	2.12	0.05	0.97	0.050	0.016	0.05	0.00	14.76	2.49	313.22	0.02	8.23
LIT-43	3.54	3.11	0.43	0.88	0.050	0.016	0.08	0.00	14.76	2.49	175.44	0.03	4.40
LIT-43	4.48	3.91	0.56	0.87	0.050	0.016	0.11	0.00	14.76	2.49	134.76	0.04	3.33
LIT-43	4.91	4.19	0.72	0.85	0.050	0.016	0.12	0.00	14.76	2.49	125.13	0.05	3.12
LIT-43	5.32	4.42	0.90	0.83	0.050	0.016	0.12	0.00	14.76	2.49	118.56	0.05	3.00
LIT-43	6.28	4.92	1.36	0.78	0.050	0.016	0.14	0.00	14.76	2.49	106.23	0.06	2.76
LIT-43	7.18	5.30	1.88	0.74	0.050	0.016	0.15	0.00	14.76	2.49	99.12	0.06	2.66
LIT-43	7.82	5.70	2.12	0.73	0.050	0.016	0.16	0.00	14.76	2.49	92.55	0.06	2.51
LIT-43	8.49	5.95	2.54	0.70	0.050	0.016	0.17	0.00	14.76	2.49	89.01	0.07	2.46
LIT-43	9.60	6.42	3.18	0.67	0.050	0.016	0.18	0.00	14.76	2.49	83.02	0.07	2.36
LIT-43	10.44	6.64	3.80	0.64	0.050	0.016	0.18	0.00	14.76	2.49	80.62	0.07	2.36
LIT-43	11.25	6.92	4.33	0.61	0.050	0.016	0.19	0.00	14.76	2.49	77.77	0.08	2.32
LIT-43	4.20	4.22	-0.02	1.00	0.005	0.031	0.12	0.00	14.76	2.49	124.02	0.05	3.97
LIT-43	4.74	4.67	0.07	0.99	0.005	0.031	0.13	0.00	14.76	2.49	112.22	0.05	3.63
LIT-43	5.29	5.11	0.18	0.97	0.005	0.031	0.14	0.00	14.76	2.49	102.55	0.06	3.35
LIT-43	5.94	5.58	0.36	0.94	0.005	0.031	0.16	0.00	14.76	2.49	94.30	0.06	3.13
LIT-43	6.54	6.00	0.54	0.92	0.005	0.031	0.17	0.00	14.76	2.49	88.31	0.07	2.98
LIT-43	6.59	6.24	0.35	0.95	0.005	0.031	0.17	0.00	14.76	2.49	85.18	0.07	2.83
LIT-43	6.94	6.55	0.39	0.94	0.005	0.031	0.18	0.00	14.76	2.49	81.52	0.07	2.72
LIT-43	7.32	6.77	0.55	0.92	0.005	0.031	0.19	0.00	14.76	2.49	79.24	0.07	2.68
LIT-43	3.72	3.72	0.00	1.00	0.010	0.031	0.10	0.00	14.76	2.49	142.50	0.04	4.60
LIT-43	3.85	3.83	0.02	0.99	0.010	0.031	0.11	0.00	14.76	2.49	137.80	0.04	4.45
LIT-43	4.30	4.15	0.15	0.97	0.010	0.031	0.12	0.00	14.76	2.49	126.48	0.05	4.13
LIT-43	4.47	4.30	0.18	0.96	0.010	0.031	0.12	0.00	14.76	2.49	122.00	0.05	4.00
LIT-43	5.29	4.81	0.48	0.91	0.010	0.031	0.14	0.00	14.76	2.49	108.87	0.05	3.66
LIT-43	6.03	5.57	0.46	0.92	0.010	0.031	0.16	0.00	14.76	2.49	94.40	0.06	3.16
LIT-43	6.51	5.86	0.65	0.90	0.010	0.031	0.16	0.00	14.76	2.49	90.09	0.07	3.06
LIT-43	7.47	6.46	1.01	0.87	0.010	0.031	0.18	0.00	14.76	2.49	82.38	0.07	2.86
LIT-43	2.86	2.85	0.02	0.99	0.020	0.031	0.08	0.00	14.76	2.49	196.51	0.03	6.54
LIT-43	3.49	3.42	0.07	0.98	0.020	0.031	0.09	0.00	14.76	2.49	156.24	0.04	5.12
LIT-43	3.74	3.61	0.13	0.96	0.020	0.031	0.10	0.00	14.76	2.49	147.14	0.04	4.84
LIT-43	3.97	3.79	0.18	0.95	0.020	0.031	0.11	0.00	14.76	2.49	139.45	0.04	4.60
LIT-43	4.34	4.01	0.33	0.92	0.020	0.031	0.11	0.00	14.76	2.49	131.21	0.05	4.39
LIT-43	5.09	4.79	0.30	0.94	0.020	0.031	0.14	0.00	14.76	2.49	108.63	0.05	3.58
LIT-43	5.78	5.17	0.62	0.89	0.020	0.031	0.15	0.00	14.76	2.49	101.47	0.06	3.45
LIT-43	6.84	5.83	1.00	0.85	0.020	0.031	0.16	0.00	14.76	2.49	90.23	0.07	3.14
LIT-43	7.44	6.17	1.27	0.83	0.020	0.031	0.17	0.00	14.76	2.49	86.00	0.07	3.05
LIT-43	7.95	6.43	1.52	0.81	0.020	0.031	0.18	0.00	14.76	2.49	82.89	0.07	2.98

Continued on next page

Table 5: Literature-Derived Performance Data for Drop-Type Inlets — Continued

ID-CODE	Q_A	Q_I	Q_O	Q_R	S_0	S_x	d_a	h_b	L_I	W_I	L_R	W_R	Fr
LIT-43	2.64	2.64	0.00	1.00	0.030	0.031	0.07	0.00	14.76	2.49	218.50	0.03	7.36
LIT-43	3.15	3.11	0.04	0.99	0.030	0.031	0.08	0.00	14.76	2.49	174.96	0.03	5.76
LIT-43	3.69	3.55	0.14	0.96	0.030	0.031	0.10	0.00	14.76	2.49	149.94	0.04	4.95
LIT-43	4.09	3.79	0.30	0.93	0.030	0.031	0.11	0.00	14.76	2.49	139.47	0.04	4.67
LIT-43	4.76	4.49	0.27	0.94	0.030	0.031	0.13	0.00	14.76	2.49	115.93	0.05	3.82
LIT-43	5.37	4.86	0.52	0.90	0.030	0.031	0.14	0.00	14.76	2.49	107.70	0.05	3.63
LIT-43	5.79	5.09	0.71	0.88	0.030	0.031	0.14	0.00	14.76	2.49	103.04	0.06	3.53
LIT-43	6.55	5.59	0.96	0.85	0.030	0.031	0.16	0.00	14.76	2.49	94.15	0.06	3.28
LIT-43	7.26	6.04	1.22	0.83	0.030	0.031	0.17	0.00	14.76	2.49	87.81	0.07	3.11
LIT-43	7.74	6.24	1.50	0.81	0.030	0.031	0.17	0.00	14.76	2.49	85.17	0.07	3.07
LIT-43	8.33	6.59	1.74	0.79	0.030	0.031	0.18	0.00	14.76	2.49	81.08	0.07	2.96
LIT-43	9.23	6.96	2.27	0.75	0.030	0.031	0.19	0.00	14.76	2.49	77.36	0.08	2.90
LIT-43	2.03	2.02	0.00	1.00	0.050	0.031	0.04	0.00	14.76	2.49	343.51	0.02	12.71
LIT-43	2.60	2.58	0.02	0.99	0.050	0.031	0.07	0.00	14.76	2.49	224.19	0.03	7.59
LIT-43	2.81	2.79	0.02	0.99	0.050	0.031	0.07	0.00	14.76	2.49	202.70	0.03	6.79
LIT-43	3.62	3.48	0.13	0.96	0.050	0.031	0.10	0.00	14.76	2.49	152.80	0.04	5.04
LIT-43	4.85	4.53	0.32	0.93	0.050	0.031	0.13	0.00	14.76	2.49	115.75	0.05	3.84
LIT-43	5.41	4.92	0.49	0.91	0.050	0.031	0.14	0.00	14.76	2.49	106.17	0.06	3.57
LIT-43	5.94	5.27	0.68	0.89	0.050	0.031	0.15	0.00	14.76	2.49	99.75	0.06	3.41
LIT-43	6.47	5.58	0.90	0.86	0.050	0.031	0.16	0.00	14.76	2.49	94.50	0.06	3.28
LIT-43	6.80	5.78	1.02	0.85	0.050	0.031	0.16	0.00	14.76	2.49	91.25	0.06	3.19
LIT-43	7.59	6.25	1.34	0.82	0.050	0.031	0.17	0.00	14.76	2.49	85.05	0.07	3.03
LIT-43	8.41	6.68	1.73	0.79	0.050	0.031	0.18	0.00	14.76	2.49	80.23	0.07	2.92
LIT-43	9.59	7.19	2.41	0.75	0.050	0.031	0.20	0.00	14.76	2.49	75.12	0.08	2.83

10 Appendix-III Texas Tech Experiment Database

The Texas Tech experimental program conducted over 270 experiments in 82 different series (combinations of models, slopes, and presence or absence of a ditch block). For this report, these experiments were grouped by series identification codes to facilitate publication of the results in a compact tabular structure. Table 6 lists the identification codes, and descriptive codes used to identify experimental conditions. These condition codes are identified in the report body.

Table 7 is a list of the performance values extracted and/or derived by calculation from the experiments listed in 6. Readers will note that each “experiment” appears in multiples of three. This appearance is intentional; every reported measurement is a result of triplicate measurements made over the course of the experiment. The use of triplicate measurements allows some assessment of variability. In most of these results, values represent spatial and time averages, but each record represents a unique set of measurements for the experimental conditions.

Table 6: Cross-Reference Identification Codes for Texas Tech Inlet Experiments.

[ID-CODE: A record identifying code to relate literature source and model type to tabulated performance data; REF-CODE: A code that identifies the data source; TYPE: A code that identifies the model type; CITATION: The citation for the literature source.

ID-CODE	REF-CODE	TYPE	CITATION
TTU-1	TxDOT-Type-H	NONE 1X1-1 4-LOW	
TTU-2	TxDOT-Type-H	PARALLEL 1X1-1 4-LOW	
TTU-3	TxDOT-Type-H	PERPINDICULAR 1X1-1 4-LOW	
TTU-4	TxDOT-Type-H	PARA-NOBLOCK 1X1-1 4-LOW	
TTU-5	TxDOT-Type-H	NONE 1X1-1 4-HIGH	
TTU-6	TxDOT-Type-H	PARALLEL 1X1-1 4-HIGH	
TTU-7	TxDOT-Type-H	NONE 1X1-1 8-LOW	
TTU-8	TxDOT-Type-H	PARALLEL 1X1-1 8-LOW	
TTU-9	TxDOT-Type-H	PERPINDICULAR 1X1-1 8-LOW	
TTU-10	TxDOT-Type-H	NONE 1X1-1 8-HIGH	
TTU-11	TxDOT-Type-H	PARALLEL 1X1-1 8-HIGH	
TTU-12	TxDOT-Type-H	PERPINDICULAR 1X1-1 8-HIGH	
TTU-13	TxDOT-Type-H	NONE 1X1-TANDEM 8-LOW	
TTU-15	TxDOT-Type-H	PARALLEL 1X1-TANDEM 8-LOW	
TTU-16	TxDOT-Type-H	PERPINDICULAR 1X1-TANDEM 8-LOW	
TTU-17	TxDOT-Type-H	PARALLEL 1X1-TANDEM 4-LOW	
TTU-19	TxDOT-Type-H	PARA-NOBLOCK 1X1-TANDEM 4-LOW	
TTU-20	TxDOT-Type-H	PARALLEL 1X1-TANDEM 8-HIGH	
TTU-21	TxDOT-Type-H	PARA-NOBLOCK 1X1-TANDEM 8-HIGH	
TTU-22	TxDOT-Type-H	NONE 2x2-1 8-LOW	

Continued on next page

Table 6: Cross-Reference Identification Codes for Texas Tech Experiments — Continued

ID-CODE	REF-CODE	TYPE	CITATION
TTU-23	TxDOT-Type-H	PARALLEL 2x2-1 8-LOW	
TTU-24	TxDOT-Type-H	PARA-NOBLOCK 2x2-1 8-LOW	
TTU-25	TxDOT-Type-H	NONE 2x2-1 12-LOW	
TTU-26	TxDOT-Type-H	PARALLEL 2x2-1 12-LOW	
TTU-27	TxDOT-Type-H	PARA-NOBLOCK 2x2-1 12-LOW	
TTU-28	TxDOT-Type-H	PARALLEL 2x4-1 12-LOW	
TTU-30	TxDOT-Type-H	PARALLEL 2x4-1 4-LOW	
TTU-31	TxDOT-Type-H	PARALLEL 2x4-1 8-LOW	
TTU-32	TxDOT-Type-H	PARALLEL 2x2-1 12-LOW	
TTU-33	TxDOT-Type-H	PARALLEL 2x2-1 8-LOW	
TTU-34	TxDOT-Type-H	PARALLEL 2x2-1 4-LOW	
TTU-35	TxDOT-Type-H	LID 2x2-1 4-LOW	
TTU-36	TxDOT-Type-H	LID 2x2-1 8-LOW	
TTU-37	TxDOT-Type-H	LID 2x2-1 12-LOW	
TTU-38	TxDOT-Type-H	PARA-NOBLOCK 2x2-1 12-LOW	
TTU-39	TxDOT-Type-H	PARA-NOBLOCK 2x2-1 8-LOW	
TTU-40	TxDOT-Type-H	PARA-NOBLOCK 2x2-1 4-LOW	
TTU-41	TxDOT-Type-H	PARALLEL 1x1-1 4-LOW	
TTU-42	TxDOT-Type-H	PARALLEL 1x1-1 8-LOW	
TTU-43	TxDOT-Type-H	PARALLEL 1x1-1 4-HIGH	
TTU-44	TxDOT-Type-H	PARA-NOBLOCK 1x1-1 4-HIGH	
TTU-45	TxDOT-Type-H	PARA-NOBLOCK 1x1-1 8-LOW	
TTU-46	TxDOT-Type-H	PARA-NOBLOCK 1x1-1 4-LOW	
TTU-47	TxDOT-Type-H	PARALLEL 1x1-1 8-HIGH	
TTU-48	TxDOT-Type-H	PARALLEL 1x1-2 8-HIGH	
TTU-49	TxDOT-Type-H	PARALLEL 1x1-2 4-HIGH	
TTU-50	TxDOT-Type-H	PARA-NOBLOCK 1x1-2 4-HIGH	
TTU-51	TxDOT-Type-H	PARA-NOBLOCK 1x1-2 8-HIGH	
TTU-52	TxDOT-Type-H	PARALLEL 1x1-2 4-LOW	
TTU-53	TxDOT-Type-H	PARALLEL 1x1-2 8-LOW	
TTU-54	TxDOT-Type-H	PARA-NOBLOCK 1x1-2 8-LOW	
TTU-55	TxDOT-Type-H	PARA-NOBLOCK 1x1-2 4-LOW	
TTU-56	TxDOT-Type-H	PARALLEL 1x1-2 4-LOW	
TTU-57	TxDOT-Type-H	PARALLEL 1x1-2 8-LOW	
TTU-58	TxDOT-Type-H	PARA-REAR 1x1-1 4-LOW	
TTU-59	TxDOT-Type-H	PARA-REAR 1x1-1 8-LOW	
TTU-60	TxDOT-Type-H	PARALLEL 1x1-1 4-LOW	
TTU-61	TxDOT-Type-H	PARALLEL 1x1-1 8-LOW	
TTU-62	TxDOT-Type-H	PARA-NOBLOCK 1x1-1 8-LOW	

Continued on next page

Table 6: Cross-Reference Identification Codes for Texas Tech Experiments — Continued

ID-CODE	REF-CODE	TYPE	CITATION
TTU-63	TxDOT-Type-H	PARA-NOBLOCK 1x1-1 4-LOW	
TTU-64	TxDOT-Type-H	PARA-NOBLOCK 1x1-2 4-LOW	
TTU-65	TxDOT-Type-H	PARA-NOBLOCK 1x1-2 8-LOW	
TTU-66	TxDOT-Type-H	PARALLEL 1x1-2 8-HIGH	
TTU-67	TxDOT-Type-H	PARALLEL 1x1-2 4-HIGH	
TTU-68	TxDOT-Type-H	PARALLEL 1x1-1 8-HIGH	
TTU-69	TxDOT-Type-H	PARA-NOBLOCK 1x1-1 8-HIGH	
TTU-70	TxDOT-Type-H	PARA-NOBLOCK 1x1-1 4-HIGH	
TTU-71	TxDOT-Type-H	PARA-NOBLOCK 1x1-2 4-HIGH	
TTU-72	TxDOT-Type-H	PARA-NOBLOCK 1x1-2 8-HIGH	
TTU-73	TxDOT-Type-H	LID 2x2-1 8-LOW	
TTU-74	TxDOT-Type-H	PARALLEL 2x2-1 8-LOW	
TTU-75	TxDOT-Type-H	PARALLEL 2x2-1 12-LOW	
TTU-76	TxDOT-Type-H	LID 2x2-1 12-LOW	
TTU-77	TxDOT-Type-H	LID 2x2-1 4-LOW	
TTU-78	TxDOT-Type-H	PARALLEL 2x2-1 4-LOW	
TTU-79	TxDOT-Type-H	PARA-NOBLOCK 2x2-1 4-LOW	
TTU-80	TxDOT-Type-H	PARA-NOBLOCK 2x2-1 8-LOW	
TTU-81	TxDOT-Type-H	PARA-NOBLOCK 2x2-1 12-LOW	
TTU-82	TxDOT-Type-H	PARALLEL 2x4-1 12-LOW	
TTU-83	TxDOT-Type-H	PARALLEL 2x4-1 8-LOW	
TTU-84	TxDOT-Type-H	PARALLEL 2x4-1 4-LOW	

Table 7: Texas Tech Experimental Performance Data for Drop-Type Inlets.

[ID-CODE, Experiment identification number; Q_A , Approach discharge (cubic feet per second); Q_I , Inlet discharge (cubic feet per second); Q_O , overflow discharge (cubic feet per second); Q_R , capture ratio ($\frac{Q_I}{Q_A}$); S_0 , Longitudinal slope; S_x , Channel side slope; d_a , approach depth (feet) ; h_b , ditch block height (feet) ; L_I , inlet length (feet) ; W_I , inlet width (feet) ; L_R , length to depth ratio ($\frac{L_I}{d_a}$) ; W_R , depth to width ratio ($\frac{d_a}{W}$); Fr , Froude number]

ID-CODE	Q_A	Q_I	Q_O	Q_R	S_0	S_x	d_a	h_b	L_I	W_I	L_R	W_R	Fr
TTU-1	0.42	0.42	0.00	1.00	0.005	0.167	0.09	0.50	1.00	1.00	11.11	0.09	0.89
TTU-1	0.44	0.44	0.00	1.00	0.005	0.167	0.09	0.50	1.00	1.00	11.11	0.09	0.93
TTU-1	0.45	0.45	0.00	1.00	0.005	0.167	0.09	0.50	1.00	1.00	11.11	0.09	0.96
TTU-1	0.64	0.49	0.16	0.76	0.005	0.167	0.34	0.50	1.00	1.00	2.95	0.34	0.08
TTU-1	0.60	0.44	0.17	0.72	0.005	0.167	0.35	0.50	1.00	1.00	2.87	0.35	0.07
TTU-1	0.66	0.47	0.19	0.71	0.005	0.167	0.34	0.50	1.00	1.00	2.96	0.34	0.08
TTU-1	0.90	0.71	0.19	0.79	0.005	0.167	0.28	0.50	1.00	1.00	3.53	0.28	0.16
TTU-1	0.84	0.66	0.19	0.78	0.005	0.167	0.28	0.50	1.00	1.00	3.53	0.28	0.15
TTU-1	0.86	0.67	0.19	0.78	0.005	0.167	0.28	0.50	1.00	1.00	3.52	0.28	0.15
TTU-1	0.82	0.62	0.20	0.75	0.005	0.167	0.34	0.50	1.00	1.00	2.95	0.34	0.10
TTU-1	0.80	0.56	0.24	0.70	0.005	0.167	0.34	0.50	1.00	1.00	2.94	0.34	0.09
TTU-1	0.71	0.48	0.23	0.68	0.005	0.167	0.34	0.50	1.00	1.00	2.93	0.34	0.08
TTU-1	2.30	0.94	1.36	0.41	0.005	0.167	0.53	0.50	1.00	1.00	1.89	0.53	0.13
TTU-1	2.18	0.75	1.43	0.34	0.005	0.167	0.57	0.50	1.00	1.00	1.76	0.57	0.13
TTU-1	2.12	0.70	1.42	0.33	0.005	0.167	0.48	0.50	1.00	1.00	2.07	0.48	0.14
TTU-2	0.32	0.32	0.00	1.00	0.005	0.167	0.09	0.50	1.00	1.00	11.24	0.09	0.66
TTU-2	0.33	0.33	0.00	1.00	0.005	0.167	0.09	0.50	1.00	1.00	11.24	0.09	0.68
TTU-2	0.36	0.36	0.00	1.00	0.005	0.167	0.09	0.50	1.00	1.00	11.24	0.09	0.75
TTU-2	1.06	0.83	0.23	0.78	0.005	0.167	0.31	0.50	1.00	1.00	3.19	0.31	0.14
TTU-2	1.04	0.81	0.23	0.78	0.005	0.167	0.31	0.50	1.00	1.00	3.19	0.31	0.14
TTU-2	1.09	0.86	0.23	0.79	0.005	0.167	0.32	0.50	1.00	1.00	3.12	0.32	0.14
TTU-2	0.92	0.92	0.00	1.00	0.005	0.167	0.30	0.50	1.00	1.00	3.32	0.30	0.14
TTU-2	0.85	0.85	0.00	1.00	0.005	0.167	0.29	0.50	1.00	1.00	3.51	0.29	0.14
TTU-2	0.85	0.85	0.00	1.00	0.005	0.167	0.29	0.50	1.00	1.00	3.51	0.29	0.14
TTU-2	1.68	1.25	0.42	0.75	0.005	0.167	0.36	0.50	1.00	1.00	2.77	0.36	0.17
TTU-2	1.68	1.19	0.49	0.71	0.005	0.167	0.36	0.50	1.00	1.00	2.77	0.36	0.16
TTU-2	1.67	1.11	0.56	0.67	0.005	0.167	0.36	0.50	1.00	1.00	2.77	0.36	0.17
TTU-2	3.18	1.47	1.71	0.46	0.005	0.167	0.44	0.50	1.00	1.00	2.25	0.44	0.24
TTU-2	3.08	1.40	1.68	0.45	0.005	0.167	0.44	0.50	1.00	1.00	2.25	0.44	0.23
TTU-2	3.08	1.59	1.49	0.52	0.005	0.167	0.44	0.50	1.00	1.00	2.25	0.44	0.23
TTU-3	2.74	1.62	1.12	0.59	0.005	0.167	0.43	0.50	1.00	1.00	2.32	0.43	0.21
TTU-3	3.03	1.70	1.33	0.56	0.005	0.167	0.45	0.50	1.00	1.00	2.21	0.45	0.22

Continued on next page

Table 7: Texas Tech Experimental Performance Data for Drop-Type Inlets — Continued

ID-CODE	Q_A	Q_I	Q_O	Q_R	S_0	S_x	d_a	h_b	L_I	W_I	L_R	W_R	Fr
TTU-3	2.88	1.55	1.32	0.54	0.005	0.167	0.44	0.50	1.00	1.00	2.29	0.44	0.22
TTU-4	0.79	0.52	0.26	0.67	0.005	0.167	0.11	0.00	1.00	1.00	9.13	0.11	1.08
TTU-4	0.77	0.51	0.26	0.66	0.005	0.167	0.11	0.00	1.00	1.00	9.13	0.11	1.06
TTU-4	0.79	0.51	0.27	0.65	0.005	0.167	0.11	0.00	1.00	1.00	9.09	0.11	1.09
TTU-4	2.72	1.05	1.67	0.38	0.005	0.167	0.25	0.00	1.00	1.00	4.05	0.25	0.66
TTU-4	2.75	1.06	1.69	0.39	0.005	0.167	0.25	0.00	1.00	1.00	4.04	0.25	0.67
TTU-4	2.74	1.03	1.72	0.37	0.005	0.167	0.25	0.00	1.00	1.00	4.05	0.25	0.67
TTU-5	0.28	0.28	0.00	1.00	0.005	0.167	0.10	0.50	1.00	1.00	10.49	0.10	0.52
TTU-5	0.27	0.27	0.00	1.00	0.005	0.167	0.10	0.50	1.00	1.00	10.49	0.10	0.50
TTU-5	0.26	0.26	0.00	1.00	0.005	0.167	0.10	0.50	1.00	1.00	10.49	0.10	0.45
TTU-5	0.82	0.47	0.35	0.57	0.005	0.167	0.32	0.50	1.00	1.00	3.08	0.32	0.10
TTU-5	0.81	0.46	0.35	0.57	0.005	0.167	0.32	0.50	1.00	1.00	3.08	0.32	0.10
TTU-5	0.79	0.44	0.35	0.55	0.005	0.167	0.32	0.50	1.00	1.00	3.08	0.32	0.10
TTU-5	0.54	0.54	0.00	1.00	0.005	0.167	0.27	0.50	1.00	1.00	3.64	0.27	0.10
TTU-5	0.55	0.55	0.00	1.00	0.005	0.167	0.27	0.50	1.00	1.00	3.64	0.27	0.10
TTU-5	0.52	0.52	0.00	1.00	0.005	0.167	0.27	0.50	1.00	1.00	3.65	0.27	0.09
TTU-5	1.02	0.25	0.78	0.24	0.005	0.167	0.34	0.50	1.00	1.00	2.96	0.34	0.12
TTU-5	1.02	0.25	0.77	0.24	0.005	0.167	0.34	0.50	1.00	1.00	2.96	0.34	0.12
TTU-5	1.03	0.23	0.80	0.22	0.005	0.167	0.34	0.50	1.00	1.00	2.94	0.34	0.12
TTU-5	2.55	0.64	1.91	0.25	0.005	0.167	0.40	0.50	1.00	1.00	2.49	0.40	0.23
TTU-5	2.52	0.58	1.94	0.23	0.005	0.167	0.40	0.50	1.00	1.00	2.49	0.40	0.22
TTU-5	2.59	0.63	1.96	0.24	0.005	0.167	0.41	0.50	1.00	1.00	2.47	0.41	0.23
TTU-6	0.60	0.60	0.00	1.00	0.005	0.167	0.15	0.50	1.00	1.00	6.85	0.15	0.47
TTU-6	0.58	0.58	0.00	1.00	0.005	0.167	0.15	0.50	1.00	1.00	6.85	0.15	0.45
TTU-6	0.54	0.54	0.00	1.00	0.005	0.167	0.15	0.50	1.00	1.00	6.85	0.15	0.43
TTU-6	0.83	0.83	0.00	1.00	0.005	0.167	0.31	0.50	1.00	1.00	3.23	0.31	0.11
TTU-6	0.83	0.83	0.00	1.00	0.005	0.167	0.31	0.50	1.00	1.00	3.23	0.31	0.11
TTU-6	0.83	0.83	0.00	1.00	0.005	0.167	0.31	0.50	1.00	1.00	3.24	0.31	0.11
TTU-6	0.53	0.53	0.00	1.00	0.005	0.167	0.28	0.50	1.00	1.00	3.56	0.28	0.09
TTU-6	0.52	0.52	0.00	1.00	0.005	0.167	0.28	0.50	1.00	1.00	3.57	0.28	0.09
TTU-6	0.51	0.51	0.00	1.00	0.005	0.167	0.27	0.50	1.00	1.00	3.66	0.27	0.09
TTU-6	0.96	0.46	0.49	0.48	0.005	0.167	0.33	0.50	1.00	1.00	3.00	0.33	0.11
TTU-6	0.99	0.46	0.53	0.46	0.005	0.167	0.33	0.50	1.00	1.00	2.99	0.33	0.12
TTU-6	0.95	0.45	0.50	0.48	0.005	0.167	0.34	0.50	1.00	1.00	2.99	0.34	0.11
TTU-6	2.66	0.70	1.97	0.26	0.005	0.167	0.42	0.50	1.00	1.00	2.38	0.42	0.22
TTU-6	2.72	0.68	2.04	0.25	0.005	0.167	0.42	0.50	1.00	1.00	2.38	0.42	0.23
TTU-6	2.72	0.65	2.07	0.24	0.005	0.167	0.42	0.50	1.00	1.00	2.37	0.42	0.23
TTU-7	0.89	0.89	0.00	1.00	0.005	0.167	0.14	0.50	1.00	1.00	7.01	0.14	0.79
TTU-7	0.91	0.91	0.00	1.00	0.005	0.167	0.14	0.50	1.00	1.00	7.01	0.14	0.80

Continued on next page

Table 7: Texas Tech Experimental Performance Data for Drop-Type Inlets — Continued

ID-CODE	Q_A	Q_I	Q_O	Q_R	S_0	S_x	d_a	h_b	L_I	W_I	L_R	W_R	Fr
TTU-7	0.82	0.82	0.00	1.00	0.005	0.167	0.14	0.50	1.00	1.00	7.17	0.14	0.75
TTU-7	2.23	2.23	0.00	1.00	0.005	0.167	0.27	0.50	1.00	1.00	3.75	0.27	0.41
TTU-7	2.34	2.34	0.00	1.00	0.005	0.167	0.26	0.50	1.00	1.00	3.78	0.26	0.44
TTU-7	2.58	2.58	0.00	1.00	0.005	0.167	0.27	0.50	1.00	1.00	3.72	0.27	0.48
TTU-7	3.42	2.93	0.49	0.86	0.005	0.167	0.43	0.50	1.00	1.00	2.30	0.43	0.30
TTU-7	3.25	2.72	0.53	0.84	0.005	0.167	0.43	0.50	1.00	1.00	2.33	0.43	0.30
TTU-7	3.35	2.86	0.49	0.85	0.005	0.167	0.43	0.50	1.00	1.00	2.30	0.43	0.30
TTU-7	5.39	3.80	1.60	0.70	0.005	0.167	0.47	0.50	1.00	1.00	2.11	0.47	0.41
TTU-7	5.64	4.07	1.56	0.72	0.005	0.167	0.48	0.50	1.00	1.00	2.08	0.48	0.42
TTU-7	5.31	3.76	1.55	0.71	0.005	0.167	0.47	0.50	1.00	1.00	2.12	0.47	0.40
TTU-8	0.38	0.38	0.00	1.00	0.005	0.167	0.09	0.50	1.00	1.00	10.55	0.09	0.67
TTU-8	0.37	0.37	0.00	1.00	0.005	0.167	0.10	0.50	1.00	1.00	10.20	0.10	0.71
TTU-8	0.36	0.36	0.00	1.00	0.005	0.167	0.10	0.50	1.00	1.00	10.18	0.10	0.70
TTU-8	0.98	0.98	0.00	1.00	0.005	0.167	0.14	0.50	1.00	1.00	7.02	0.14	0.89
TTU-8	0.94	0.94	0.00	1.00	0.005	0.167	0.13	0.50	1.00	1.00	7.76	0.13	0.93
TTU-8	0.92	0.92	0.00	1.00	0.005	0.167	0.13	0.50	1.00	1.00	7.75	0.13	0.85
TTU-8	1.88	1.88	0.00	1.00	0.005	0.167	0.25	0.50	1.00	1.00	3.96	0.25	0.40
TTU-8	1.92	1.92	0.00	1.00	0.005	0.167	0.25	0.50	1.00	1.00	3.98	0.25	0.41
TTU-8	2.00	2.00	0.00	1.00	0.005	0.167	0.26	0.50	1.00	1.00	3.91	0.26	0.42
TTU-8	3.26	2.70	0.56	0.83	0.005	0.167	0.38	0.50	1.00	1.00	2.61	0.38	0.30
TTU-8	3.32	2.66	0.66	0.80	0.005	0.167	0.39	0.50	1.00	1.00	2.59	0.39	0.31
TTU-8	3.35	2.73	0.62	0.81	0.005	0.167	0.39	0.50	1.00	1.00	2.59	0.39	0.31
TTU-8	5.04	2.61	2.43	0.52	0.005	0.167	0.42	0.50	1.00	1.00	2.39	0.42	0.41
TTU-8	5.28	3.41	1.87	0.65	0.005	0.167	0.43	0.50	1.00	1.00	2.33	0.43	0.41
TTU-8	5.06	3.15	1.91	0.62	0.005	0.167	0.42	0.50	1.00	1.00	2.36	0.42	0.40
TTU-9	0.40	0.40	0.00	1.00	0.005	0.167	0.11	0.50	1.00	1.00	8.89	0.11	0.65
TTU-9	0.40	0.40	0.00	1.00	0.005	0.167	0.11	0.50	1.00	1.00	8.89	0.11	0.66
TTU-9	0.40	0.40	0.00	1.00	0.005	0.167	0.11	0.50	1.00	1.00	8.89	0.11	0.64
TTU-9	0.90	0.90	0.00	1.00	0.005	0.167	0.13	0.50	1.00	1.00	7.68	0.13	0.84
TTU-9	0.92	0.92	0.00	1.00	0.005	0.167	0.13	0.50	1.00	1.00	7.44	0.13	0.84
TTU-9	0.89	0.89	0.00	1.00	0.005	0.167	0.13	0.50	1.00	1.00	7.79	0.13	0.87
TTU-9	2.15	2.15	0.00	1.00	0.005	0.167	0.27	0.50	1.00	1.00	3.74	0.27	0.44
TTU-9	2.02	2.02	0.00	1.00	0.005	0.167	0.27	0.50	1.00	1.00	3.71	0.27	0.40
TTU-9	2.19	2.19	0.00	1.00	0.005	0.167	0.29	0.50	1.00	1.00	3.46	0.29	0.38
TTU-9	2.44	1.78	0.66	0.73	0.005	0.167	0.36	0.50	1.00	1.00	2.79	0.36	0.26
TTU-9	2.41	1.79	0.62	0.74	0.005	0.167	0.36	0.50	1.00	1.00	2.80	0.36	0.26
TTU-9	2.43	1.79	0.64	0.74	0.005	0.167	0.36	0.50	1.00	1.00	2.79	0.36	0.26
TTU-9	3.79	1.94	1.85	0.51	0.005	0.167	0.41	0.50	1.00	1.00	2.43	0.41	0.33
TTU-9	3.78	1.81	1.97	0.48	0.005	0.167	0.41	0.50	1.00	1.00	2.43	0.41	0.33

Continued on next page

Table 7: Texas Tech Experimental Performance Data for Drop-Type Inlets — Continued

ID-CODE	Q_A	Q_I	Q_O	Q_R	S_0	S_x	d_a	h_b	L_I	W_I	L_R	W_R	Fr
TTU-9	3.85	2.02	1.83	0.53	0.005	0.167	0.41	0.50	1.00	1.00	2.44	0.41	0.33
TTU-10	0.41	0.41	0.00	1.00	0.005	0.167	0.11	0.50	1.00	1.00	8.77	0.11	0.67
TTU-10	0.42	0.42	0.00	1.00	0.005	0.167	0.11	0.50	1.00	1.00	8.77	0.11	0.67
TTU-10	0.40	0.40	0.00	1.00	0.005	0.167	0.11	0.50	1.00	1.00	8.93	0.11	0.66
TTU-10	0.82	0.82	0.00	1.00	0.005	0.167	0.12	0.50	1.00	1.00	8.53	0.12	0.92
TTU-10	0.81	0.81	0.00	1.00	0.005	0.167	0.12	0.50	1.00	1.00	8.55	0.12	0.92
TTU-10	0.80	0.80	0.00	1.00	0.005	0.167	0.12	0.50	1.00	1.00	8.55	0.12	0.90
TTU-10	1.39	1.39	0.00	1.00	0.005	0.167	0.25	0.50	1.00	1.00	4.07	0.25	0.34
TTU-10	1.51	1.51	0.00	1.00	0.005	0.167	0.25	0.50	1.00	1.00	4.06	0.25	0.36
TTU-10	1.71	1.71	0.00	1.00	0.005	0.167	0.26	0.50	1.00	1.00	3.91	0.26	0.39
TTU-10	2.53	1.69	0.84	0.67	0.005	0.167	0.37	0.50	1.00	1.00	2.72	0.37	0.25
TTU-10	2.46	1.63	0.83	0.66	0.005	0.167	0.37	0.50	1.00	1.00	2.72	0.37	0.24
TTU-10	2.49	1.62	0.87	0.65	0.005	0.167	0.37	0.50	1.00	1.00	2.72	0.37	0.25
TTU-10	3.41	1.63	1.78	0.48	0.005	0.167	0.43	0.50	1.00	1.00	2.32	0.43	0.28
TTU-10	3.33	1.57	1.76	0.47	0.005	0.167	0.43	0.50	1.00	1.00	2.32	0.43	0.28
TTU-10	3.42	1.65	1.77	0.48	0.005	0.167	0.43	0.50	1.00	1.00	2.32	0.43	0.27
TTU-11	0.34	0.34	0.00	1.00	0.005	0.167	0.09	0.50	1.00	1.00	11.14	0.09	0.67
TTU-11	0.32	0.32	0.00	1.00	0.005	0.167	0.09	0.50	1.00	1.00	10.90	0.09	0.59
TTU-11	0.29	0.29	0.00	1.00	0.005	0.167	0.09	0.50	1.00	1.00	11.14	0.09	0.55
TTU-11	0.46	0.46	0.00	1.00	0.005	0.167	0.10	0.50	1.00	1.00	10.53	0.10	0.79
TTU-11	0.56	0.56	0.00	1.00	0.005	0.167	0.10	0.50	1.00	1.00	10.28	0.10	0.93
TTU-11	0.60	0.60	0.00	1.00	0.005	0.167	0.10	0.50	1.00	1.00	10.28	0.10	0.98
TTU-11	0.76	0.76	0.00	1.00	0.005	0.167	0.12	0.50	1.00	1.00	8.25	0.12	0.82
TTU-11	0.78	0.78	0.00	1.00	0.005	0.167	0.12	0.50	1.00	1.00	8.25	0.12	0.85
TTU-11	0.75	0.75	0.00	1.00	0.005	0.167	0.12	0.50	1.00	1.00	8.21	0.12	0.81
TTU-11	1.89	1.89	0.00	1.00	0.005	0.167	0.27	0.50	1.00	1.00	3.72	0.27	0.38
TTU-11	1.82	1.82	0.00	1.00	0.005	0.167	0.27	0.50	1.00	1.00	3.72	0.27	0.37
TTU-11	1.85	1.85	0.00	1.00	0.005	0.167	0.27	0.50	1.00	1.00	3.72	0.27	0.37
TTU-11	1.68	1.68	0.00	1.00	0.005	0.167	0.25	0.50	1.00	1.00	3.95	0.25	0.37
TTU-11	1.80	1.80	0.00	1.00	0.005	0.167	0.25	0.50	1.00	1.00	4.07	0.25	0.45
TTU-11	1.60	1.60	0.00	1.00	0.005	0.167	0.19	0.50	1.00	1.00	5.28	0.19	0.67
TTU-11	2.04	1.76	0.28	0.86	0.005	0.167	0.35	0.50	1.00	1.00	2.84	0.35	0.22
TTU-11	2.08	1.79	0.29	0.86	0.005	0.167	0.35	0.50	1.00	1.00	2.85	0.35	0.23
TTU-11	2.05	1.71	0.34	0.83	0.005	0.167	0.35	0.50	1.00	1.00	2.87	0.35	0.23
TTU-11	3.51	2.37	1.14	0.67	0.005	0.167	0.42	0.50	1.00	1.00	2.39	0.42	0.31
TTU-11	3.57	2.12	1.45	0.59	0.005	0.167	0.42	0.50	1.00	1.00	2.38	0.42	0.30
TTU-11	3.54	2.13	1.41	0.60	0.005	0.167	0.42	0.50	1.00	1.00	2.39	0.42	0.30
TTU-12	3.43	1.66	1.77	0.48	0.005	0.167	0.43	0.50	1.00	1.00	2.34	0.43	0.28
TTU-12	3.46	1.69	1.77	0.49	0.005	0.167	0.43	0.50	1.00	1.00	2.34	0.43	0.28

Continued on next page

Table 7: Texas Tech Experimental Performance Data for Drop-Type Inlets — Continued

ID-CODE	Q_A	Q_I	Q_O	Q_R	S_0	S_x	d_a	h_b	L_I	W_I	L_R	W_R	Fr
TTU-12	3.46	1.74	1.72	0.50	0.005	0.167	0.43	0.50	1.00	1.00	2.34	0.43	0.28
TTU-13	0.82	0.82	0.00	1.00	0.005	0.167	0.12	0.50	2.00	1.00	17.00	0.12	0.95
TTU-13	0.81	0.81	0.00	1.00	0.005	0.167	0.12	0.50	2.00	1.00	17.05	0.12	0.94
TTU-13	0.84	0.84	0.00	1.00	0.005	0.167	0.12	0.50	2.00	1.00	17.00	0.12	0.97
TTU-13	1.16	1.16	0.00	1.00	0.005	0.167	0.14	0.50	2.00	1.00	14.71	0.14	0.98
TTU-13	1.17	1.17	0.00	1.00	0.005	0.167	0.14	0.50	2.00	1.00	14.71	0.14	0.99
TTU-13	1.19	1.19	0.00	1.00	0.005	0.167	0.14	0.50	2.00	1.00	14.78	0.14	1.00
TTU-13	3.25	3.25	0.00	1.00	0.005	0.167	0.22	0.50	2.00	1.00	8.94	0.22	0.93
TTU-13	3.21	3.21	0.00	1.00	0.005	0.167	0.22	0.50	2.00	1.00	8.94	0.22	0.92
TTU-13	3.15	3.15	0.00	1.00	0.005	0.167	0.22	0.50	2.00	1.00	8.92	0.22	0.90
TTU-13	3.95	3.63	0.32	0.92	0.005	0.167	0.32	0.50	2.00	1.00	6.30	0.32	0.49
TTU-13	4.00	3.71	0.28	0.93	0.005	0.167	0.32	0.50	2.00	1.00	6.30	0.32	0.50
TTU-13	4.01	3.76	0.25	0.94	0.005	0.167	0.32	0.50	2.00	1.00	6.31	0.32	0.50
TTU-13	4.60	3.75	0.85	0.82	0.005	0.167	0.38	0.50	2.00	1.00	5.33	0.38	0.45
TTU-13	4.71	3.85	0.85	0.82	0.005	0.167	0.38	0.50	2.00	1.00	5.33	0.38	0.46
TTU-13	4.77	3.91	0.86	0.82	0.005	0.167	0.38	0.50	2.00	1.00	5.31	0.38	0.47
TTU-15	0.76	0.76	0.00	1.00	0.005	0.167	0.11	0.50	2.00	1.00	18.18	0.11	0.98
TTU-15	0.76	0.76	0.00	1.00	0.005	0.167	0.11	0.50	2.00	1.00	18.18	0.11	0.99
TTU-15	0.75	0.75	0.00	1.00	0.005	0.167	0.11	0.50	2.00	1.00	18.24	0.11	0.96
TTU-15	1.22	1.22	0.00	1.00	0.005	0.167	0.15	0.50	2.00	1.00	13.57	0.15	0.95
TTU-15	1.22	1.22	0.00	1.00	0.005	0.167	0.15	0.50	2.00	1.00	13.61	0.15	0.95
TTU-15	1.24	1.24	0.00	1.00	0.005	0.167	0.15	0.50	2.00	1.00	13.67	0.15	0.96
TTU-15	3.67	3.67	0.00	1.00	0.005	0.167	0.25	0.50	2.00	1.00	7.87	0.25	0.85
TTU-15	3.69	3.69	0.00	1.00	0.005	0.167	0.25	0.50	2.00	1.00	7.87	0.25	0.85
TTU-15	3.66	3.66	0.00	1.00	0.005	0.167	0.25	0.50	2.00	1.00	7.92	0.25	0.87
TTU-15	3.89	3.55	0.34	0.91	0.005	0.167	0.33	0.50	2.00	1.00	6.15	0.33	0.47
TTU-15	3.84	3.49	0.35	0.91	0.005	0.167	0.33	0.50	2.00	1.00	6.15	0.33	0.47
TTU-15	3.84	3.49	0.35	0.91	0.005	0.167	0.33	0.50	2.00	1.00	6.15	0.33	0.47
TTU-15	4.06	3.26	0.80	0.80	0.005	0.167	0.35	0.50	2.00	1.00	5.65	0.35	0.43
TTU-15	4.17	3.33	0.84	0.80	0.005	0.167	0.35	0.50	2.00	1.00	5.65	0.35	0.45
TTU-15	4.17	3.26	0.91	0.78	0.005	0.167	0.35	0.50	2.00	1.00	5.65	0.35	0.45
TTU-16	4.21	3.41	0.80	0.81	0.005	0.167	0.34	0.50	2.00	1.00	5.91	0.34	0.48
TTU-16	4.18	3.36	0.81	0.80	0.005	0.167	0.34	0.50	2.00	1.00	5.91	0.34	0.48
TTU-16	4.22	3.42	0.80	0.81	0.005	0.167	0.34	0.50	2.00	1.00	5.91	0.34	0.48
TTU-17	0.85	0.85	0.00	1.00	0.005	0.167	0.12	0.50	2.00	1.00	16.67	0.12	0.96
TTU-17	0.87	0.87	0.00	1.00	0.005	0.167	0.12	0.50	2.00	1.00	16.67	0.12	0.98
TTU-17	0.88	0.88	0.00	1.00	0.005	0.167	0.12	0.50	2.00	1.00	16.67	0.12	0.99
TTU-17	1.30	1.30	0.00	1.00	0.005	0.167	0.27	0.50	2.00	1.00	7.46	0.27	0.24
TTU-17	1.36	1.36	0.00	1.00	0.005	0.167	0.27	0.50	2.00	1.00	7.45	0.27	0.25

Continued on next page

Table 7: Texas Tech Experimental Performance Data for Drop-Type Inlets — Continued

ID-CODE	Q_A	Q_I	Q_O	Q_R	S_0	S_x	d_a	h_b	L_I	W_I	L_R	W_R	Fr
TTU-17	1.33	1.33	0.00	1.00	0.005	0.167	0.27	0.50	2.00	1.00	7.45	0.27	0.24
TTU-17	2.14	1.49	0.65	0.70	0.005	0.167	0.34	0.50	2.00	1.00	5.82	0.34	0.24
TTU-17	2.17	1.49	0.68	0.69	0.005	0.167	0.34	0.50	2.00	1.00	5.82	0.34	0.25
TTU-17	2.20	1.74	0.46	0.79	0.005	0.167	0.34	0.50	2.00	1.00	5.82	0.34	0.25
TTU-17	2.82	1.69	1.13	0.60	0.005	0.167	0.39	0.50	2.00	1.00	5.18	0.39	0.26
TTU-17	2.86	1.73	1.13	0.60	0.005	0.167	0.39	0.50	2.00	1.00	5.18	0.39	0.27
TTU-17	2.82	1.69	1.13	0.60	0.005	0.167	0.39	0.50	2.00	1.00	5.18	0.39	0.26
TTU-19	1.45	1.10	0.36	0.76	0.005	0.167	0.15	0.00	2.00	1.00	13.79	0.15	1.11
TTU-19	1.48	1.07	0.41	0.72	0.005	0.167	0.15	0.00	2.00	1.00	13.57	0.15	1.10
TTU-19	1.46	1.05	0.41	0.72	0.005	0.167	0.15	0.00	2.00	1.00	13.57	0.15	1.10
TTU-19	2.13	1.23	0.90	0.58	0.005	0.167	0.17	0.00	2.00	1.00	11.72	0.17	1.11
TTU-19	2.08	1.19	0.89	0.57	0.005	0.167	0.17	0.00	2.00	1.00	11.58	0.17	1.03
TTU-19	2.08	1.17	0.91	0.56	0.005	0.167	0.17	0.00	2.00	1.00	11.58	0.17	1.03
TTU-20	2.84	0.55	2.29	0.19	0.005	0.167	0.45	0.50	2.00	1.00	4.45	0.45	0.21
TTU-20	2.81	0.50	2.31	0.18	0.005	0.167	0.45	0.50	2.00	1.00	4.45	0.45	0.21
TTU-20	2.76	0.50	2.26	0.18	0.005	0.167	0.45	0.50	2.00	1.00	4.45	0.45	0.21
TTU-20	2.16	0.68	1.48	0.31	0.005	0.167	0.40	0.50	2.00	1.00	4.94	0.40	0.19
TTU-20	2.17	0.71	1.46	0.33	0.005	0.167	0.40	0.50	2.00	1.00	4.94	0.40	0.19
TTU-20	2.18	0.70	1.49	0.32	0.005	0.167	0.40	0.50	2.00	1.00	4.94	0.40	0.19
TTU-20	0.65	0.65	0.00	1.00	0.005	0.167	0.27	0.50	2.00	1.00	7.38	0.27	0.13
TTU-20	0.63	0.63	0.00	1.00	0.005	0.167	0.27	0.50	2.00	1.00	7.38	0.27	0.12
TTU-20	0.65	0.65	0.00	1.00	0.005	0.167	0.27	0.50	2.00	1.00	7.38	0.27	0.13
TTU-20	0.82	0.59	0.23	0.73	0.005	0.167	0.32	0.50	2.00	1.00	6.30	0.32	0.11
TTU-20	0.82	0.61	0.21	0.74	0.005	0.167	0.32	0.50	2.00	1.00	6.31	0.32	0.11
TTU-20	0.82	0.53	0.29	0.65	0.005	0.167	0.32	0.50	2.00	1.00	6.31	0.32	0.11
TTU-20	1.31	1.31	0.00	1.00	0.005	0.167	0.14	0.50	2.00	1.00	14.18	0.14	1.00
TTU-20	1.35	1.35	0.00	1.00	0.005	0.167	0.14	0.50	2.00	1.00	14.32	0.14	1.03
TTU-20	1.38	1.38	0.00	1.00	0.005	0.167	0.14	0.50	2.00	1.00	13.92	0.14	0.98
TTU-20	2.01	2.01	0.00	1.00	0.005	0.167	0.27	0.50	2.00	1.00	7.36	0.27	0.40
TTU-20	2.07	2.07	0.00	1.00	0.005	0.167	0.27	0.50	2.00	1.00	7.36	0.27	0.41
TTU-20	2.10	2.10	0.00	1.00	0.005	0.167	0.27	0.50	2.00	1.00	7.36	0.27	0.41
TTU-20	2.95	2.06	0.89	0.70	0.005	0.167	0.37	0.50	2.00	1.00	5.40	0.37	0.29
TTU-20	2.93	1.72	1.20	0.59	0.005	0.167	0.37	0.50	2.00	1.00	5.40	0.37	0.29
TTU-20	2.88	1.99	0.89	0.69	0.005	0.167	0.37	0.50	2.00	1.00	5.40	0.37	0.29
TTU-20	3.56	2.19	1.37	0.62	0.005	0.167	0.42	0.50	2.00	1.00	4.76	0.42	0.29
TTU-20	3.61	2.26	1.35	0.63	0.005	0.167	0.42	0.50	2.00	1.00	4.76	0.42	0.30
TTU-20	3.66	2.29	1.37	0.63	0.005	0.167	0.42	0.50	2.00	1.00	4.76	0.42	0.30
TTU-21	2.98	1.89	1.09	0.64	0.005	0.167	0.21	0.00	2.00	1.00	9.69	0.21	1.01
TTU-21	3.02	1.89	1.13	0.63	0.005	0.167	0.21	0.00	2.00	1.00	9.66	0.21	1.04

Continued on next page

Table 7: Texas Tech Experimental Performance Data for Drop-Type Inlets — Continued

ID-CODE	Q_A	Q_I	Q_O	Q_R	S_0	S_x	d_a	h_b	L_I	W_I	L_R	W_R	Fr
TTU-21	3.06	1.94	1.12	0.63	0.005	0.167	0.21	0.00	2.00	1.00	9.46	0.21	1.02
TTU-21	2.20	1.91	0.29	0.87	0.005	0.167	0.19	0.00	2.00	1.00	10.77	0.19	1.00
TTU-21	2.27	1.97	0.30	0.87	0.005	0.167	0.19	0.00	2.00	1.00	10.51	0.19	1.00
TTU-21	2.28	2.01	0.27	0.88	0.005	0.167	0.19	0.00	2.00	1.00	10.51	0.19	1.00
TTU-22	2.10	2.10	0.00	1.00	0.005	0.167	0.27	0.50	2.00	2.00	7.29	0.14	0.38
TTU-22	2.14	2.14	0.00	1.00	0.005	0.167	0.28	0.50	2.00	2.00	7.24	0.14	0.38
TTU-22	2.25	2.25	0.00	1.00	0.005	0.167	0.28	0.50	2.00	2.00	7.13	0.14	0.39
TTU-22	3.74	2.45	1.29	0.66	0.005	0.167	0.41	0.50	2.00	2.00	4.84	0.21	0.32
TTU-22	3.75	2.58	1.17	0.69	0.005	0.167	0.41	0.50	2.00	2.00	4.83	0.21	0.32
TTU-22	3.75	2.67	1.08	0.71	0.005	0.167	0.41	0.50	2.00	2.00	4.83	0.21	0.32
TTU-23	1.28	1.28	0.00	1.00	0.005	0.167	0.14	0.50	2.00	2.00	13.99	0.07	1.01
TTU-23	1.30	1.30	0.00	1.00	0.005	0.167	0.14	0.50	2.00	2.00	13.99	0.07	1.03
TTU-23	1.30	1.30	0.00	1.00	0.005	0.167	0.14	0.50	2.00	2.00	13.99	0.07	1.03
TTU-23	2.07	2.07	0.00	1.00	0.005	0.167	0.27	0.50	2.00	2.00	7.43	0.13	0.38
TTU-23	2.07	2.07	0.00	1.00	0.005	0.167	0.27	0.50	2.00	2.00	7.43	0.13	0.38
TTU-23	2.06	2.06	0.00	1.00	0.005	0.167	0.27	0.50	2.00	2.00	7.43	0.13	0.38
TTU-23	3.28	2.33	0.95	0.71	0.005	0.167	0.38	0.50	2.00	2.00	5.32	0.19	0.31
TTU-23	3.28	2.23	1.05	0.68	0.005	0.167	0.38	0.50	2.00	2.00	5.32	0.19	0.31
TTU-23	3.52	2.51	1.02	0.71	0.005	0.167	0.38	0.50	2.00	2.00	5.32	0.19	0.34
TTU-23	3.62	2.41	1.20	0.67	0.005	0.167	0.39	0.50	2.00	2.00	5.08	0.20	0.33
TTU-23	3.69	2.52	1.17	0.68	0.005	0.167	0.39	0.50	2.00	2.00	5.08	0.20	0.34
TTU-23	3.78	2.61	1.17	0.69	0.005	0.167	0.39	0.50	2.00	2.00	5.08	0.20	0.34
TTU-24	2.20	1.77	0.43	0.81	0.005	0.167	0.18	0.00	2.00	2.00	11.07	0.09	1.03
TTU-24	2.35	1.89	0.46	0.80	0.005	0.167	0.19	0.00	2.00	2.00	10.75	0.09	1.03
TTU-24	2.33	1.88	0.45	0.81	0.005	0.167	0.18	0.00	2.00	2.00	10.91	0.09	1.03
TTU-24	3.32	2.42	0.90	0.73	0.005	0.167	0.22	0.00	2.00	2.00	8.97	0.11	1.02
TTU-24	3.32	2.38	0.94	0.72	0.005	0.167	0.23	0.00	2.00	2.00	8.88	0.11	1.01
TTU-24	3.37	2.44	0.94	0.72	0.005	0.167	0.23	0.00	2.00	2.00	8.88	0.11	1.02
TTU-25	3.64	3.64	0.00	1.00	0.005	0.167	0.25	0.50	2.00	2.00	8.11	0.12	0.91
TTU-25	3.88	3.88	0.00	1.00	0.005	0.167	0.25	0.50	2.00	2.00	8.13	0.12	0.96
TTU-25	3.81	3.81	0.00	1.00	0.005	0.167	0.25	0.50	2.00	2.00	8.13	0.12	0.94
TTU-25	4.15	4.15	0.00	1.00	0.005	0.167	0.33	0.50	2.00	2.00	6.08	0.16	0.50
TTU-25	4.07	4.07	0.00	1.00	0.005	0.167	0.33	0.50	2.00	2.00	6.08	0.16	0.49
TTU-25	4.02	4.02	0.00	1.00	0.005	0.167	0.33	0.50	2.00	2.00	6.09	0.16	0.48
TTU-26	3.03	3.03	0.00	1.00	0.005	0.167	0.22	0.50	2.00	2.00	8.98	0.11	0.97
TTU-26	3.09	3.09	0.00	1.00	0.005	0.167	0.23	0.50	2.00	2.00	8.81	0.11	0.96
TTU-26	3.11	3.11	0.00	1.00	0.005	0.167	0.23	0.50	2.00	2.00	8.80	0.11	0.97
TTU-26	3.70	3.70	0.00	1.00	0.005	0.167	0.24	0.50	2.00	2.00	8.40	0.12	0.97
TTU-26	3.59	3.59	0.00	1.00	0.005	0.167	0.24	0.50	2.00	2.00	8.42	0.12	0.94

Continued on next page

Table 7: Texas Tech Experimental Performance Data for Drop-Type Inlets — Continued

ID-CODE	Q_A	Q_I	Q_O	Q_R	S_0	S_x	d_a	h_b	L_I	W_I	L_R	W_R	Fr
TTU-26	3.65	3.65	0.00	1.00	0.005	0.167	0.24	0.50	2.00	2.00	8.42	0.12	0.96
TTU-26	4.24	4.24	0.00	1.00	0.005	0.167	0.34	0.50	2.00	2.00	5.96	0.17	0.49
TTU-26	4.06	4.06	0.00	1.00	0.005	0.167	0.32	0.50	2.00	2.00	6.17	0.16	0.50
TTU-26	4.01	4.01	0.00	1.00	0.005	0.167	0.33	0.50	2.00	2.00	6.15	0.16	0.48
TTU-26	4.82	3.79	1.03	0.79	0.005	0.167	0.37	0.50	2.00	2.00	5.39	0.19	0.48
TTU-26	4.74	3.74	1.01	0.79	0.005	0.167	0.36	0.50	2.00	2.00	5.48	0.18	0.48
TTU-26	4.81	3.81	1.00	0.79	0.005	0.167	0.36	0.50	2.00	2.00	5.48	0.18	0.49
TTU-27	2.35	1.96	0.39	0.83	0.005	0.167	0.19	0.00	2.00	2.00	10.51	0.10	0.99
TTU-27	2.43	2.08	0.35	0.86	0.005	0.167	0.20	0.00	2.00	2.00	10.26	0.10	0.98
TTU-27	2.42	1.97	0.45	0.81	0.005	0.167	0.20	0.00	2.00	2.00	10.26	0.10	0.98
TTU-27	3.81	3.24	0.57	0.85	0.005	0.167	0.22	0.00	2.00	2.00	8.93	0.11	1.05
TTU-27	3.88	3.32	0.56	0.86	0.005	0.167	0.22	0.00	2.00	2.00	8.94	0.11	1.07
TTU-27	3.94	3.37	0.56	0.86	0.005	0.167	0.22	0.00	2.00	2.00	8.96	0.11	1.08
TTU-28	3.09	3.09	0.00	1.00	0.005	0.167	0.21	0.50	4.00	2.00	19.27	0.10	1.06
TTU-28	3.02	3.02	0.00	1.00	0.005	0.167	0.21	0.50	4.00	2.00	19.34	0.10	1.05
TTU-28	3.00	3.00	0.00	1.00	0.005	0.167	0.21	0.50	4.00	2.00	19.36	0.10	1.03
TTU-28	4.04	4.04	0.00	1.00	0.005	0.167	0.25	0.50	4.00	2.00	16.26	0.12	1.00
TTU-28	3.83	3.83	0.00	1.00	0.005	0.167	0.25	0.50	4.00	2.00	15.94	0.13	0.99
TTU-28	3.83	3.83	0.00	1.00	0.005	0.167	0.25	0.50	4.00	2.00	15.91	0.13	0.99
TTU-28	5.17	4.71	0.46	0.91	0.005	0.167	0.30	0.50	4.00	2.00	13.40	0.15	0.77
TTU-28	5.17	4.71	0.47	0.91	0.005	0.167	0.30	0.50	4.00	2.00	13.40	0.15	0.77
TTU-28	5.27	4.86	0.41	0.92	0.005	0.167	0.30	0.50	4.00	2.00	13.40	0.15	0.79
TTU-28	4.66	3.48	1.19	0.75	0.005	0.167	0.32	0.50	4.00	2.00	12.58	0.16	0.57
TTU-28	5.58	4.31	1.27	0.77	0.005	0.167	0.32	0.50	4.00	2.00	12.56	0.16	0.69
TTU-28	5.57	4.68	0.89	0.84	0.005	0.167	0.32	0.50	4.00	2.00	12.56	0.16	0.69
TTU-28	1.15	1.15	0.00	1.00	0.005	0.167	0.13	0.50	4.00	2.00	29.90	0.07	1.01
TTU-28	1.17	1.17	0.00	1.00	0.005	0.167	0.13	0.50	4.00	2.00	29.94	0.07	1.03
TTU-28	1.16	1.16	0.00	1.00	0.005	0.167	0.13	0.50	4.00	2.00	29.94	0.07	1.02
TTU-28	1.90	1.90	0.00	1.00	0.005	0.167	0.25	0.50	4.00	2.00	15.74	0.13	0.43
TTU-28	1.90	1.90	0.00	1.00	0.005	0.167	0.25	0.50	4.00	2.00	15.74	0.13	0.43
TTU-28	1.92	1.92	0.00	1.00	0.005	0.167	0.25	0.50	4.00	2.00	15.74	0.13	0.43
TTU-28	2.77	1.86	0.91	0.67	0.005	0.167	0.34	0.50	4.00	2.00	11.86	0.17	0.32
TTU-28	2.69	1.82	0.87	0.68	0.005	0.167	0.34	0.50	4.00	2.00	11.88	0.17	0.31
TTU-28	2.70	1.81	0.89	0.67	0.005	0.167	0.34	0.50	4.00	2.00	11.86	0.17	0.31
TTU-28	3.35	1.79	1.57	0.53	0.005	0.167	0.39	0.50	4.00	2.00	10.24	0.20	0.31
TTU-28	3.40	1.92	1.49	0.56	0.005	0.167	0.39	0.50	4.00	2.00	10.20	0.20	0.31
TTU-28	3.43	1.85	1.58	0.54	0.005	0.167	0.39	0.50	4.00	2.00	10.20	0.20	0.31
TTU-30	0.46	0.46	0.00	1.00	0.005	0.167	0.09	0.50	4.00	2.00	44.44	0.05	0.96
TTU-30	0.47	0.47	0.00	1.00	0.005	0.167	0.09	0.50	4.00	2.00	43.76	0.05	0.96

Continued on next page

Table 7: Texas Tech Experimental Performance Data for Drop-Type Inlets — Continued

ID-CODE	Q_A	Q_I	Q_O	Q_R	S_0	S_x	d_a	h_b	L_I	W_I	L_R	W_R	Fr
TTU-30	0.48	0.48	0.00	1.00	0.005	0.167	0.09	0.50	4.00	2.00	42.92	0.05	0.94
TTU-30	0.84	0.84	0.00	1.00	0.005	0.167	0.29	0.50	4.00	2.00	13.71	0.15	0.12
TTU-30	0.83	0.83	0.00	1.00	0.005	0.167	0.29	0.50	4.00	2.00	13.71	0.15	0.12
TTU-30	0.82	0.82	0.00	1.00	0.005	0.167	0.29	0.50	4.00	2.00	13.71	0.15	0.12
TTU-30	0.77	0.77	0.00	1.00	0.005	0.167	0.25	0.50	4.00	2.00	15.84	0.13	0.17
TTU-30	0.77	0.77	0.00	1.00	0.005	0.167	0.25	0.50	4.00	2.00	16.00	0.13	0.17
TTU-30	0.74	0.74	0.00	1.00	0.005	0.167	0.24	0.50	4.00	2.00	16.47	0.12	0.18
TTU-30	1.59	0.64	0.96	0.40	0.005	0.167	0.38	0.50	4.00	2.00	10.54	0.19	0.15
TTU-30	1.59	0.60	0.99	0.38	0.005	0.167	0.38	0.50	4.00	2.00	10.54	0.19	0.15
TTU-30	1.59	0.61	0.97	0.39	0.005	0.167	0.38	0.50	4.00	2.00	10.54	0.19	0.15
TTU-30	2.34	0.82	1.52	0.35	0.010	0.167	0.24	0.50	4.00	2.00	16.63	0.12	0.62
TTU-30	2.32	0.57	1.75	0.24	0.010	0.167	0.24	0.50	4.00	2.00	16.65	0.12	0.62
TTU-30	2.22	0.52	1.70	0.23	0.010	0.167	0.24	0.50	4.00	2.00	16.68	0.12	0.61
TTU-30	1.65	0.62	1.03	0.38	0.010	0.167	0.23	0.50	4.00	2.00	17.72	0.11	0.52
TTU-30	1.63	0.61	1.02	0.38	0.010	0.167	0.22	0.50	4.00	2.00	17.82	0.11	0.52
TTU-30	1.58	1.07	0.51	0.68	0.010	0.167	0.22	0.50	4.00	2.00	17.92	0.11	0.52
TTU-30	0.92	0.92	0.00	1.00	0.010	0.167	0.15	0.50	4.00	2.00	25.86	0.08	0.64
TTU-30	0.78	0.78	0.00	1.00	0.010	0.167	0.16	0.50	4.00	2.00	24.95	0.08	0.46
TTU-30	0.80	0.80	0.00	1.00	0.010	0.167	0.17	0.50	4.00	2.00	22.94	0.09	0.40
TTU-31	4.16	2.61	1.54	0.63	0.010	0.167	0.20	0.50	4.00	2.00	19.75	0.10	1.48
TTU-31	3.89	2.62	1.27	0.67	0.010	0.167	0.21	0.50	4.00	2.00	19.18	0.10	1.35
TTU-31	4.19	2.64	1.55	0.63	0.010	0.167	0.21	0.50	4.00	2.00	19.00	0.11	1.40
TTU-31	3.19	2.38	0.81	0.74	0.010	0.167	0.18	0.50	4.00	2.00	22.60	0.09	1.58
TTU-31	3.19	2.23	0.96	0.70	0.010	0.167	0.18	0.50	4.00	2.00	22.54	0.09	1.59
TTU-31	3.20	2.15	1.05	0.67	0.010	0.167	0.18	0.50	4.00	2.00	22.54	0.09	1.58
TTU-31	2.36	2.27	0.09	0.96	0.010	0.167	0.14	0.50	4.00	2.00	27.78	0.07	1.81
TTU-31	2.33	2.46	-0.12	1.05	0.010	0.167	0.14	0.50	4.00	2.00	28.22	0.07	1.83
TTU-31	2.36	2.57	-0.21	1.09	0.010	0.167	0.14	0.50	4.00	2.00	27.83	0.07	1.81
TTU-32	5.35	4.03	1.32	0.75	0.010	0.167	0.21	0.50	4.00	2.00	19.30	0.10	1.75
TTU-32	5.45	3.95	1.50	0.72	0.010	0.167	0.21	0.50	4.00	2.00	19.00	0.11	1.73
TTU-32	5.50	4.41	1.09	0.80	0.010	0.167	0.21	0.50	4.00	2.00	19.00	0.11	1.75
TTU-32	4.31	3.89	0.42	0.90	0.010	0.167	0.19	0.50	4.00	2.00	21.11	0.09	1.75
TTU-32	4.30	3.82	0.48	0.89	0.010	0.167	0.19	0.50	4.00	2.00	21.14	0.09	1.75
TTU-32	4.29	3.90	0.39	0.91	0.010	0.167	0.19	0.50	4.00	2.00	21.08	0.09	1.75
TTU-32	4.04	4.04	0.00	1.00	0.010	0.167	0.19	0.50	4.00	2.00	21.36	0.09	1.70
TTU-32	4.07	4.07	0.00	1.00	0.010	0.167	0.19	0.50	4.00	2.00	21.33	0.09	1.72
TTU-32	4.02	4.02	0.00	1.00	0.010	0.167	0.19	0.50	4.00	2.00	21.30	0.09	1.70
TTU-32	5.04	4.24	0.80	0.84	0.010	0.167	0.22	0.50	2.00	2.00	8.99	0.11	1.55
TTU-32	4.96	4.16	0.81	0.84	0.010	0.167	0.22	0.50	2.00	2.00	9.08	0.11	1.55

Continued on next page

Table 7: Texas Tech Experimental Performance Data for Drop-Type Inlets — Continued

ID-CODE	Q_A	Q_I	Q_O	Q_R	S_0	S_x	d_a	h_b	L_I	W_I	L_R	W_R	Fr
TTU-32	4.93	4.07	0.86	0.83	0.010	0.167	0.22	0.50	2.00	2.00	9.06	0.11	1.54
TTU-32	5.01	4.58	0.43	0.91	0.010	0.167	0.22	0.50	2.00	2.00	8.96	0.11	1.53
TTU-32	4.97	4.60	0.37	0.93	0.010	0.167	0.22	0.50	2.00	2.00	8.99	0.11	1.55
TTU-32	5.18	4.75	0.43	0.92	0.010	0.167	0.22	0.50	2.00	2.00	9.02	0.11	1.59
TTU-32	3.64	3.64	0.00	1.00	0.010	0.167	0.18	0.50	2.00	2.00	11.10	0.09	1.75
TTU-32	3.73	3.73	0.00	1.00	0.010	0.167	0.19	0.50	2.00	2.00	10.62	0.09	1.70
TTU-32	3.63	3.63	0.00	1.00	0.010	0.167	0.18	0.50	2.00	2.00	11.07	0.09	1.75
TTU-32	3.00	3.00	0.00	1.00	0.010	0.167	0.16	0.50	2.00	2.00	12.58	0.08	1.79
TTU-32	2.90	2.90	0.00	1.00	0.010	0.167	0.16	0.50	2.00	2.00	12.42	0.08	1.73
TTU-32	2.92	2.92	0.00	1.00	0.010	0.167	0.16	0.50	2.00	2.00	12.70	0.08	1.78
TTU-33	2.11	2.11	0.00	1.00	0.010	0.167	0.14	0.50	2.00	2.00	14.57	0.07	1.77
TTU-33	2.22	2.22	0.00	1.00	0.010	0.167	0.14	0.50	2.00	2.00	14.23	0.07	1.78
TTU-33	2.23	2.23	0.00	1.00	0.010	0.167	0.14	0.50	2.00	2.00	14.23	0.07	1.78
TTU-33	1.91	1.91	0.00	1.00	0.010	0.167	0.14	0.50	2.00	2.00	14.34	0.07	1.65
TTU-33	1.95	1.95	0.00	1.00	0.010	0.167	0.14	0.50	2.00	2.00	14.36	0.07	1.67
TTU-33	1.94	1.94	0.00	1.00	0.010	0.167	0.14	0.50	2.00	2.00	14.36	0.07	1.66
TTU-33	2.75	1.96	0.79	0.71	0.010	0.167	0.16	0.50	2.00	2.00	12.46	0.08	1.51
TTU-33	2.86	2.20	0.66	0.77	0.010	0.167	0.16	0.50	2.00	2.00	12.27	0.08	1.54
TTU-33	2.86	2.14	0.72	0.75	0.010	0.167	0.17	0.50	2.00	2.00	11.90	0.08	1.50
TTU-33	3.60	2.07	1.53	0.57	0.010	0.167	0.19	0.50	2.00	2.00	10.51	0.10	1.48
TTU-33	3.59	2.09	1.51	0.58	0.010	0.167	0.19	0.50	2.00	2.00	10.40	0.10	1.47
TTU-33	3.68	2.25	1.43	0.61	0.010	0.167	0.19	0.50	2.00	2.00	10.42	0.10	1.50
TTU-34	2.10	0.71	1.39	0.34	0.010	0.167	0.23	0.50	2.00	2.00	8.69	0.12	0.61
TTU-34	2.12	0.66	1.45	0.31	0.010	0.167	0.23	0.50	2.00	2.00	8.59	0.12	0.60
TTU-34	2.20	0.81	1.39	0.37	0.010	0.167	0.24	0.50	2.00	2.00	8.32	0.12	0.60
TTU-34	1.59	0.61	0.98	0.38	0.010	0.167	0.22	0.50	2.00	2.00	9.03	0.11	0.51
TTU-34	1.56	0.65	0.92	0.41	0.010	0.167	0.22	0.50	2.00	2.00	9.05	0.11	0.51
TTU-34	1.50	0.59	0.90	0.40	0.010	0.167	0.22	0.50	2.00	2.00	9.05	0.11	0.49
TTU-34	0.79	0.79	0.00	1.00	0.010	0.167	0.16	0.50	2.00	2.00	12.62	0.08	0.53
TTU-34	0.87	0.87	0.00	1.00	0.010	0.167	0.16	0.50	2.00	2.00	12.62	0.08	0.55
TTU-34	0.79	0.79	0.00	1.00	0.010	0.167	0.16	0.50	2.00	2.00	12.62	0.08	0.54
TTU-34	0.36	0.36	0.00	1.00	0.010	0.167	0.07	0.50	2.00	2.00	30.77	0.03	1.36
TTU-34	0.30	0.30	0.00	1.00	0.010	0.167	0.07	0.50	2.00	2.00	29.13	0.03	1.05
TTU-35	2.26	0.70	1.56	0.31	0.010	0.167	0.25	0.50	2.00	2.00	8.01	0.12	0.56
TTU-35	2.22	0.71	1.51	0.32	0.010	0.167	0.24	0.50	2.00	2.00	8.23	0.12	0.58
TTU-35	2.46	0.98	1.48	0.40	0.010	0.167	0.25	0.50	2.00	2.00	8.03	0.12	0.64
TTU-35	0.99	0.99	0.00	1.00	0.010	0.167	0.19	0.50	2.00	2.00	10.42	0.10	0.40
TTU-35	0.93	0.93	0.00	1.00	0.010	0.167	0.19	0.50	2.00	2.00	10.42	0.10	0.37
TTU-35	0.92	0.92	0.00	1.00	0.010	0.167	0.19	0.50	2.00	2.00	10.45	0.10	0.37

Continued on next page

Table 7: Texas Tech Experimental Performance Data for Drop-Type Inlets — Continued

ID-CODE	Q_A	Q_I	Q_O	Q_R	S_0	S_x	d_a	h_b	L_I	W_I	L_R	W_R	Fr
TTU-35	0.65	0.65	0.00	1.00	0.010	0.167	0.14	0.50	2.00	2.00	13.89	0.07	0.46
TTU-35	0.60	0.60	0.00	1.00	0.010	0.167	0.14	0.50	2.00	2.00	13.89	0.07	0.42
TTU-35	0.70	0.70	0.00	1.00	0.010	0.167	0.14	0.50	2.00	2.00	13.89	0.07	0.49
TTU-36	2.64	1.93	0.71	0.73	0.010	0.167	0.18	0.50	2.00	2.00	10.93	0.09	1.22
TTU-36	2.56	1.90	0.66	0.74	0.010	0.167	0.19	0.50	2.00	2.00	10.80	0.09	1.16
TTU-36	2.64	1.81	0.83	0.68	0.010	0.167	0.19	0.50	2.00	2.00	10.68	0.09	1.18
TTU-36	2.19	2.19	0.00	1.00	0.010	0.167	0.17	0.50	2.00	2.00	11.96	0.08	1.37
TTU-36	2.28	2.28	0.00	1.00	0.010	0.167	0.17	0.50	2.00	2.00	11.78	0.08	1.38
TTU-36	2.46	2.46	0.00	1.00	0.010	0.167	0.17	0.50	2.00	2.00	11.78	0.08	1.45
TTU-36	1.83	1.83	0.00	1.00	0.010	0.167	0.13	0.50	2.00	2.00	15.56	0.06	1.70
TTU-36	1.77	1.77	0.00	1.00	0.010	0.167	0.13	0.50	2.00	2.00	15.75	0.06	1.69
TTU-36	1.71	1.71	0.00	1.00	0.010	0.167	0.13	0.50	2.00	2.00	15.72	0.06	1.65
TTU-37	4.73	3.43	1.30	0.73	0.010	0.167	0.21	0.50	2.00	2.00	9.65	0.10	1.61
TTU-37	4.93	3.86	1.07	0.78	0.010	0.167	0.22	0.50	2.00	2.00	9.22	0.11	1.59
TTU-37	4.56	3.50	1.06	0.77	0.010	0.167	0.21	0.50	2.00	2.00	9.66	0.10	1.59
TTU-37	3.08	3.08	0.00	1.00	0.010	0.167	0.18	0.50	2.00	2.00	11.20	0.09	1.51
TTU-37	3.03	3.03	0.00	1.00	0.010	0.167	0.18	0.50	2.00	2.00	11.10	0.09	1.46
TTU-37	3.01	3.01	0.00	1.00	0.010	0.167	0.18	0.50	2.00	2.00	11.10	0.09	1.47
TTU-37	2.16	2.16	0.00	1.00	0.010	0.167	0.14	0.50	2.00	2.00	13.82	0.07	1.67
TTU-37	2.14	2.14	0.00	1.00	0.010	0.167	0.15	0.50	2.00	2.00	13.79	0.07	1.67
TTU-37	2.17	2.17	0.00	1.00	0.010	0.167	0.15	0.50	2.00	2.00	13.79	0.07	1.69
TTU-38	4.19	2.90	1.29	0.69	0.010	0.167	0.19	0.00	2.00	2.00	10.62	0.09	1.80
TTU-38	4.19	2.90	1.29	0.69	0.010	0.167	0.19	0.00	2.00	2.00	10.62	0.09	1.80
TTU-38	4.36	3.07	1.29	0.70	0.010	0.167	0.19	0.00	2.00	2.00	10.45	0.10	1.83
TTU-38	2.91	2.37	0.53	0.82	0.010	0.167	0.16	0.00	2.00	2.00	12.66	0.08	1.82
TTU-38	2.89	2.43	0.46	0.84	0.010	0.167	0.16	0.00	2.00	2.00	12.71	0.08	1.80
TTU-38	2.88	2.45	0.43	0.85	0.010	0.167	0.16	0.00	2.00	2.00	12.71	0.08	1.80
TTU-39	2.48	2.02	0.46	0.81	0.010	0.167	0.15	0.00	2.00	2.00	13.51	0.07	1.85
TTU-39	2.49	1.97	0.52	0.79	0.010	0.167	0.15	0.00	2.00	2.00	13.51	0.07	1.85
TTU-39	2.51	2.09	0.42	0.83	0.010	0.167	0.15	0.00	2.00	2.00	13.51	0.07	1.87
TTU-39	3.42	2.02	1.41	0.59	0.010	0.167	0.17	0.00	2.00	2.00	11.58	0.09	1.79
TTU-39	3.41	2.04	1.37	0.60	0.010	0.167	0.17	0.00	2.00	2.00	11.88	0.08	1.83
TTU-39	3.28	1.90	1.38	0.58	0.010	0.167	0.16	0.00	2.00	2.00	12.42	0.08	1.87
TTU-40	1.94	0.84	1.11	0.43	0.010	0.167	0.12	0.00	2.00	2.00	16.04	0.06	1.93
TTU-40	1.91	0.74	1.18	0.39	0.010	0.167	0.12	0.00	2.00	2.00	16.04	0.06	1.90
TTU-40	1.95	0.81	1.14	0.42	0.010	0.167	0.13	0.00	2.00	2.00	15.75	0.06	1.88
TTU-40	1.45	0.74	0.71	0.51	0.010	0.167	0.11	0.00	2.00	2.00	18.35	0.05	1.86
TTU-40	1.44	0.69	0.76	0.48	0.010	0.167	0.11	0.00	2.00	2.00	17.96	0.06	1.79
TTU-40	1.50	0.00	1.50	0.00	0.010	0.167	0.11	0.00	2.00	2.00	17.96	0.06	1.85

Continued on next page

Table 7: Texas Tech Experimental Performance Data for Drop-Type Inlets — Continued

ID-CODE	Q_A	Q_I	Q_O	Q_R	S_0	S_x	d_a	h_b	L_I	W_I	L_R	W_R	Fr
TTU-41	2.27	0.72	1.55	0.32	0.010	0.167	0.23	0.50	2.00	2.00	8.65	0.12	0.60
TTU-41	2.47	0.90	1.58	0.36	0.010	0.167	0.24	0.50	1.00	1.00	4.10	0.24	0.62
TTU-41	2.30	0.78	1.52	0.34	0.010	0.167	0.24	0.50	1.00	1.00	4.25	0.24	0.62
TTU-41	0.87	0.87	0.00	1.00	0.010	0.167	0.19	0.50	1.00	1.00	5.25	0.19	0.45
TTU-41	0.85	0.85	0.00	1.00	0.010	0.167	0.19	0.50	1.00	1.00	5.23	0.19	0.44
TTU-41	0.88	0.88	0.00	1.00	0.010	0.167	0.19	0.50	1.00	1.00	5.24	0.19	0.45
TTU-41	1.47	0.94	0.54	0.64	0.010	0.167	0.22	0.50	1.00	1.00	4.54	0.22	0.49
TTU-41	1.44	0.99	0.45	0.69	0.010	0.167	0.22	0.50	1.00	1.00	4.56	0.22	0.49
TTU-41	1.47	1.11	0.36	0.76	0.010	0.167	0.22	0.50	1.00	1.00	4.53	0.22	0.48
TTU-41	0.84	0.84	0.00	1.00	0.010	0.167	0.11	0.50	1.00	1.00	9.09	0.11	1.15
TTU-41	0.89	0.89	0.00	1.00	0.010	0.167	0.11	0.50	1.00	1.00	8.77	0.11	1.28
TTU-41	0.82	0.82	0.00	1.00	0.010	0.167	0.11	0.50	1.00	1.00	8.77	0.11	1.17
TTU-42	0.94	0.94	0.00	1.00	0.010	0.167	0.13	0.50	1.00	1.00	7.87	0.13	1.09
TTU-42	0.94	0.94	0.00	1.00	0.010	0.167	0.15	0.50	1.00	1.00	6.62	0.15	0.96
TTU-42	1.03	1.03	0.00	1.00	0.010	0.167	0.13	0.50	1.00	1.00	7.91	0.13	1.23
TTU-42	3.61	2.32	1.30	0.64	0.010	0.167	0.22	0.50	1.00	1.00	4.49	0.22	1.09
TTU-42	3.70	2.51	1.19	0.68	0.010	0.167	0.23	0.50	1.00	1.00	4.43	0.23	1.11
TTU-42	4.14	2.83	1.30	0.69	0.010	0.167	0.23	0.50	1.00	1.00	4.40	0.23	1.17
TTU-42	3.22	2.41	0.81	0.75	0.010	0.167	0.23	0.50	1.00	1.00	4.38	0.23	0.99
TTU-42	3.33	2.43	0.90	0.73	0.010	0.167	0.23	0.50	1.00	1.00	4.29	0.23	0.98
TTU-42	3.10	2.30	0.80	0.74	0.010	0.167	0.22	0.50	1.00	1.00	4.47	0.22	0.98
TTU-42	1.32	1.32	0.00	1.00	0.010	0.167	0.14	0.50	1.00	1.00	7.10	0.14	1.19
TTU-42	1.25	1.25	0.00	1.00	0.010	0.167	0.14	0.50	1.00	1.00	7.02	0.14	1.09
TTU-42	1.32	1.32	0.00	1.00	0.010	0.167	0.14	0.50	1.00	1.00	7.16	0.14	1.19
TTU-43	2.24	0.82	1.42	0.36	0.010	0.167	0.24	0.50	1.00	1.00	4.20	0.24	0.59
TTU-43	2.22	0.92	1.31	0.41	0.010	0.167	0.24	0.50	1.00	1.00	4.22	0.24	0.59
TTU-43	2.30	0.95	1.35	0.41	0.010	0.167	0.24	0.50	1.00	1.00	4.23	0.24	0.61
TTU-43	1.68	0.64	1.03	0.38	0.010	0.167	0.24	0.50	1.00	1.00	4.17	0.24	0.48
TTU-43	1.76	0.76	1.00	0.43	0.010	0.167	0.24	0.50	1.00	1.00	4.21	0.24	0.49
TTU-43	1.74	0.71	1.03	0.41	0.010	0.167	0.24	0.50	1.00	1.00	4.20	0.24	0.49
TTU-43	0.26	0.26	0.00	1.00	0.010	0.167	0.17	0.50	1.00	1.00	5.95	0.17	0.13
TTU-43	0.30	0.30	0.00	1.00	0.010	0.167	0.18	0.50	1.00	1.00	5.56	0.18	0.13
TTU-43	0.30	0.30	0.00	1.00	0.010	0.167	0.18	0.50	1.00	1.00	5.56	0.18	0.13
TTU-43	0.50	0.50	0.00	1.00	0.010	0.167	0.17	0.50	1.00	1.00	5.93	0.17	0.34
TTU-43	0.50	0.50	0.00	1.00	0.010	0.167	0.17	0.50	1.00	1.00	5.95	0.17	0.34
TTU-43	0.58	0.58	0.00	1.00	0.010	0.167	0.17	0.50	1.00	1.00	5.95	0.17	0.38
TTU-44	1.67	0.43	1.23	0.26	0.010	0.167	0.12	0.00	1.00	1.00	8.44	0.12	1.90
TTU-44	1.70	0.47	1.22	0.28	0.010	0.167	0.12	0.00	1.00	1.00	8.44	0.12	1.94
TTU-44	1.69	0.35	1.33	0.21	0.010	0.167	0.12	0.00	1.00	1.00	8.44	0.12	1.93

Continued on next page

Table 7: Texas Tech Experimental Performance Data for Drop-Type Inlets — Continued

ID-CODE	Q_A	Q_I	Q_O	Q_R	S_0	S_x	d_a	h_b	L_I	W_I	L_R	W_R	Fr
TTU-44	1.28	0.34	0.94	0.26	0.010	0.167	0.10	0.00	1.00	1.00	9.62	0.10	1.90
TTU-44	1.30	0.34	0.96	0.26	0.010	0.167	0.10	0.00	1.00	1.00	9.65	0.10	1.91
TTU-44	1.29	0.43	0.86	0.33	0.010	0.167	0.10	0.00	1.00	1.00	9.65	0.10	1.90
TTU-45	2.19	1.00	1.18	0.46	0.010	0.167	0.13	0.00	1.00	1.00	7.50	0.13	1.91
TTU-45	2.22	1.17	1.05	0.53	0.010	0.167	0.14	0.00	1.00	1.00	7.37	0.14	1.90
TTU-45	2.21	1.10	1.12	0.50	0.010	0.167	0.14	0.00	1.00	1.00	7.35	0.14	1.90
TTU-45	1.55	0.82	0.73	0.53	0.010	0.167	0.11	0.00	1.00	1.00	8.77	0.11	1.84
TTU-45	1.56	0.99	0.58	0.63	0.010	0.167	0.11	0.00	1.00	1.00	8.80	0.11	1.85
TTU-45	1.56	1.04	0.53	0.66	0.010	0.167	0.11	0.00	1.00	1.00	8.80	0.11	1.85
TTU-46	1.47	0.62	0.85	0.42	0.010	0.167	0.11	0.00	1.00	1.00	8.88	0.11	1.84
TTU-46	1.48	0.53	0.95	0.36	0.010	0.167	0.11	0.00	1.00	1.00	8.90	0.11	1.84
TTU-46	1.48	0.58	0.90	0.39	0.010	0.167	0.11	0.00	1.00	1.00	8.90	0.11	1.84
TTU-46	2.20	0.48	1.71	0.22	0.010	0.167	0.14	0.00	1.00	1.00	7.35	0.14	1.87
TTU-46	2.22	0.52	1.70	0.23	0.010	0.167	0.14	0.00	1.00	1.00	7.35	0.14	1.89
TTU-46	2.18	0.48	1.70	0.22	0.010	0.167	0.14	0.00	1.00	1.00	7.35	0.14	1.86
TTU-47	2.81	1.55	1.26	0.55	0.010	0.167	0.22	0.50	1.00	1.00	4.50	0.22	0.95
TTU-47	2.82	1.53	1.29	0.54	0.010	0.167	0.23	0.50	1.00	1.00	4.40	0.23	0.92
TTU-47	2.89	1.59	1.30	0.55	0.010	0.167	0.23	0.50	1.00	1.00	4.42	0.23	0.96
TTU-47	2.23	1.46	0.77	0.66	0.010	0.167	0.24	0.50	1.00	1.00	4.18	0.24	0.66
TTU-47	2.23	1.44	0.79	0.64	0.010	0.167	0.23	0.50	1.00	1.00	4.28	0.23	0.67
TTU-47	2.30	1.53	0.78	0.66	0.010	0.167	0.23	0.50	1.00	1.00	4.29	0.23	0.71
TTU-47	1.28	1.28	0.00	1.00	0.010	0.167	0.16	0.50	1.00	1.00	6.22	0.16	0.94
TTU-47	1.30	1.30	0.00	1.00	0.010	0.167	0.16	0.50	1.00	1.00	6.08	0.16	0.90
TTU-47	1.23	1.23	0.00	1.00	0.010	0.167	0.16	0.50	1.00	1.00	6.08	0.16	0.85
TTU-47	0.86	0.86	0.00	1.00	0.010	0.167	0.10	0.50	1.00	1.00	10.38	0.10	1.53
TTU-47	0.88	0.88	0.00	1.00	0.010	0.167	0.10	0.50	1.00	1.00	10.38	0.10	1.56
TTU-47	0.83	0.83	0.00	1.00	0.010	0.167	0.09	0.50	1.00	1.00	10.56	0.09	1.52
TTU-48	2.99	1.86	1.13	0.62	0.010	0.167	0.20	0.50	2.00	1.00	9.96	0.20	1.18
TTU-48	2.94	1.66	1.27	0.57	0.010	0.167	0.20	0.50	2.00	1.00	9.91	0.20	1.15
TTU-48	3.18	1.96	1.22	0.62	0.010	0.167	0.20	0.50	2.00	1.00	9.91	0.20	1.22
TTU-48	2.50	1.99	0.51	0.80	0.010	0.167	0.18	0.50	2.00	1.00	10.90	0.18	1.22
TTU-48	2.52	2.06	0.46	0.82	0.010	0.167	0.19	0.50	2.00	1.00	10.81	0.19	1.22
TTU-48	2.53	2.05	0.48	0.81	0.010	0.167	0.19	0.50	2.00	1.00	10.81	0.19	1.24
TTU-48	1.70	1.70	0.00	1.00	0.010	0.167	0.14	0.50	2.00	1.00	14.04	0.14	1.46
TTU-48	1.72	1.72	0.00	1.00	0.010	0.167	0.14	0.50	2.00	1.00	14.26	0.14	1.49
TTU-48	1.75	1.75	0.00	1.00	0.010	0.167	0.14	0.50	2.00	1.00	14.13	0.14	1.50
TTU-48	1.27	1.27	0.00	1.00	0.010	0.167	0.10	0.50	2.00	1.00	19.46	0.10	1.87
TTU-48	1.28	1.28	0.00	1.00	0.010	0.167	0.11	0.50	2.00	1.00	18.78	0.11	1.78
TTU-48	1.28	1.28	0.00	1.00	0.010	0.167	0.10	0.50	2.00	1.00	19.46	0.10	1.88

Continued on next page

Table 7: Texas Tech Experimental Performance Data for Drop-Type Inlets — Continued

ID-CODE	Q_A	Q_I	Q_O	Q_R	S_0	S_x	d_a	h_b	L_I	W_I	L_R	W_R	Fr
TTU-49	1.98	0.41	1.58	0.21	0.010	0.167	0.24	0.50	2.00	1.00	8.34	0.24	0.52
TTU-49	2.01	0.55	1.46	0.27	0.010	0.167	0.24	0.50	2.00	1.00	8.31	0.24	0.53
TTU-49	1.94	0.40	1.54	0.21	0.010	0.167	0.24	0.50	2.00	1.00	8.36	0.24	0.51
TTU-49	1.42	0.44	0.99	0.31	0.010	0.167	0.23	0.50	2.00	1.00	8.78	0.23	0.45
TTU-49	1.42	0.46	0.96	0.32	0.010	0.167	0.23	0.50	2.00	1.00	8.66	0.23	0.43
TTU-49	1.47	0.48	0.99	0.33	0.010	0.167	0.23	0.50	2.00	1.00	8.55	0.23	0.43
TTU-49	0.70	0.70	0.00	1.00	0.010	0.167	0.18	0.50	2.00	1.00	10.91	0.18	0.33
TTU-49	0.66	0.66	0.00	1.00	0.010	0.167	0.19	0.50	2.00	1.00	10.79	0.19	0.30
TTU-49	0.66	0.66	0.00	1.00	0.010	0.167	0.18	0.50	2.00	1.00	10.83	0.18	0.30
TTU-49	0.44	0.44	0.00	1.00	0.010	0.167	0.08	0.50	2.00	1.00	26.67	0.08	1.26
TTU-49	0.53	0.53	0.00	1.00	0.010	0.167	0.08	0.50	2.00	1.00	26.67	0.08	1.53
TTU-49	0.51	0.51	0.00	1.00	0.010	0.167	0.08	0.50	2.00	1.00	26.67	0.08	1.45
TTU-50	1.89	0.61	1.29	0.32	0.010	0.167	0.12	0.00	2.00	1.00	16.09	0.12	1.87
TTU-50	1.84	0.56	1.28	0.31	0.010	0.167	0.12	0.00	2.00	1.00	16.44	0.12	1.89
TTU-50	1.81	0.23	1.57	0.13	0.010	0.167	0.12	0.00	2.00	1.00	16.44	0.12	1.85
TTU-50	1.55	0.47	1.08	0.30	0.010	0.167	0.12	0.00	2.00	1.00	17.09	0.12	1.80
TTU-50	1.45	0.39	1.06	0.27	0.010	0.167	0.11	0.00	2.00	1.00	18.24	0.11	1.88
TTU-50	1.45	0.45	1.00	0.31	0.010	0.167	0.11	0.00	2.00	1.00	18.24	0.11	1.87
TTU-51	2.68	1.77	0.91	0.66	0.010	0.167	0.15	0.00	2.00	1.00	13.25	0.15	1.86
TTU-51	2.63	1.60	1.03	0.61	0.010	0.167	0.15	0.00	2.00	1.00	13.19	0.15	1.84
TTU-51	2.63	1.58	1.05	0.60	0.010	0.167	0.15	0.00	2.00	1.00	13.19	0.15	1.85
TTU-51	3.40	1.79	1.62	0.53	0.010	0.167	0.17	0.00	2.00	1.00	11.61	0.17	1.85
TTU-51	3.24	1.63	1.61	0.50	0.010	0.167	0.17	0.00	2.00	1.00	11.88	0.17	1.84
TTU-51	3.34	1.69	1.65	0.51	0.010	0.167	0.17	0.00	2.00	1.00	11.72	0.17	1.86
TTU-51	2.65	1.13	1.52	0.43	0.010	0.167	0.15	0.00	1.00	1.00	6.55	0.15	1.83
TTU-51	2.68	1.17	1.51	0.44	0.010	0.167	0.15	0.00	1.00	1.00	6.62	0.15	1.87
TTU-51	2.63	1.12	1.51	0.43	0.010	0.167	0.15	0.00	1.00	1.00	6.62	0.15	1.83
TTU-51	3.03	1.28	1.76	0.42	0.010	0.167	0.16	0.00	1.00	1.00	6.17	0.16	1.85
TTU-51	3.06	1.25	1.81	0.41	0.010	0.167	0.16	0.00	1.00	1.00	6.28	0.16	1.91
TTU-51	3.03	1.16	1.87	0.38	0.010	0.167	0.16	0.00	1.00	1.00	6.26	0.16	1.89
TTU-52	2.65	1.28	1.37	0.48	0.010	0.167	0.22	0.50	2.00	1.00	9.15	0.22	0.92
TTU-52	2.69	1.33	1.36	0.50	0.010	0.167	0.22	0.50	2.00	1.00	9.29	0.22	0.94
TTU-52	2.69	1.34	1.36	0.50	0.010	0.167	0.22	0.50	2.00	1.00	9.27	0.22	0.95
TTU-52	1.96	1.14	0.82	0.58	0.010	0.167	0.20	0.50	2.00	1.00	10.04	0.20	0.84
TTU-52	2.01	1.30	0.71	0.65	0.010	0.167	0.20	0.50	2.00	1.00	10.06	0.20	0.86
TTU-52	2.03	1.22	0.81	0.60	0.010	0.167	0.20	0.50	2.00	1.00	10.04	0.20	0.86
TTU-52	1.45	1.45	0.00	1.00	0.010	0.167	0.12	0.50	2.00	1.00	16.60	0.12	1.60
TTU-52	1.45	1.45	0.00	1.00	0.010	0.167	0.12	0.50	2.00	1.00	16.63	0.12	1.60
TTU-52	1.48	1.48	0.00	1.00	0.010	0.167	0.12	0.50	2.00	1.00	16.63	0.12	1.62

Continued on next page

Table 7: Texas Tech Experimental Performance Data for Drop-Type Inlets — Continued

ID-CODE	Q_A	Q_I	Q_O	Q_R	S_0	S_x	d_a	h_b	L_I	W_I	L_R	W_R	Fr
TTU-52	1.10	1.10	0.00	1.00	0.010	0.167	0.10	0.50	2.00	1.00	20.25	0.10	1.81
TTU-52	1.12	1.12	0.00	1.00	0.010	0.167	0.10	0.50	2.00	1.00	20.15	0.10	1.85
TTU-52	1.15	1.15	0.00	1.00	0.010	0.167	0.10	0.50	2.00	1.00	20.15	0.10	1.91
TTU-53	4.91	3.73	1.18	0.76	0.010	0.167	0.22	0.50	2.00	1.00	9.03	0.22	1.50
TTU-53	4.87	3.70	1.16	0.76	0.010	0.167	0.22	0.50	2.00	1.00	9.26	0.22	1.53
TTU-53	4.91	3.76	1.16	0.76	0.010	0.167	0.22	0.50	2.00	1.00	9.04	0.22	1.50
TTU-53	4.25	3.65	0.59	0.86	0.010	0.167	0.20	0.50	2.00	1.00	9.91	0.20	1.60
TTU-53	4.26	3.70	0.57	0.87	0.010	0.167	0.21	0.50	2.00	1.00	9.67	0.21	1.56
TTU-53	4.20	3.62	0.58	0.86	0.010	0.167	0.20	0.50	2.00	1.00	9.98	0.20	1.60
TTU-53	2.72	2.72	0.00	1.00	0.010	0.167	0.15	0.50	2.00	1.00	12.94	0.15	1.68
TTU-53	2.68	2.68	0.00	1.00	0.010	0.167	0.15	0.50	2.00	1.00	13.29	0.15	1.70
TTU-53	2.68	2.68	0.00	1.00	0.010	0.167	0.15	0.50	2.00	1.00	13.31	0.15	1.70
TTU-53	2.07	2.07	0.00	1.00	0.010	0.167	0.14	0.50	2.00	1.00	14.49	0.14	1.70
TTU-53	2.27	2.27	0.00	1.00	0.010	0.167	0.15	0.50	2.00	1.00	13.75	0.15	1.72
TTU-53	2.28	2.28	0.00	1.00	0.010	0.167	0.15	0.50	2.00	1.00	13.75	0.15	1.73
TTU-54	3.52	2.46	1.06	0.70	0.010	0.167	0.17	0.00	2.00	1.00	11.53	0.17	1.80
TTU-54	3.54	2.37	1.17	0.67	0.010	0.167	0.17	0.00	2.00	1.00	11.61	0.17	1.83
TTU-54	3.53	2.45	1.08	0.69	0.010	0.167	0.17	0.00	2.00	1.00	11.63	0.17	1.82
TTU-54	2.94	2.22	0.72	0.76	0.010	0.167	0.16	0.00	2.00	1.00	12.55	0.16	1.83
TTU-54	2.94	2.09	0.85	0.71	0.010	0.167	0.16	0.00	2.00	1.00	12.50	0.16	1.84
TTU-54	2.91	1.88	1.03	0.65	0.010	0.167	0.16	0.00	2.00	1.00	12.50	0.16	1.82
TTU-55	2.42	1.43	0.99	0.59	0.010	0.167	0.14	0.00	2.00	1.00	14.08	0.14	1.88
TTU-55	2.45	1.47	0.97	0.60	0.010	0.167	0.14	0.00	2.00	1.00	14.08	0.14	1.90
TTU-55	2.44	1.47	0.97	0.60	0.010	0.167	0.14	0.00	2.00	1.00	14.08	0.14	1.89
TTU-55	2.90	1.30	1.59	0.45	0.010	0.167	0.16	0.00	2.00	1.00	12.74	0.16	1.85
TTU-55	2.89	1.28	1.61	0.44	0.010	0.167	0.16	0.00	2.00	1.00	12.82	0.16	1.83
TTU-55	2.90	1.26	1.65	0.43	0.010	0.167	0.16	0.00	2.00	1.00	12.79	0.16	1.85
TTU-56	2.88	1.48	1.40	0.51	0.020	0.167	0.14	0.50	2.00	1.00	14.73	0.14	2.37
TTU-56	2.89	1.53	1.35	0.53	0.020	0.167	0.14	0.50	2.00	1.00	14.73	0.14	2.38
TTU-56	2.91	1.54	1.37	0.53	0.020	0.167	0.14	0.50	2.00	1.00	14.73	0.14	2.39
TTU-56	2.31	1.47	0.83	0.64	0.020	0.167	0.12	0.50	2.00	1.00	16.16	0.12	2.34
TTU-56	2.52	1.66	0.85	0.66	0.020	0.167	0.13	0.50	2.00	1.00	15.66	0.13	2.32
TTU-56	4.29	3.45	0.84	0.80	0.020	0.167	0.24	0.50	2.00	1.00	8.48	0.24	1.70
TTU-56	2.21	2.21	0.00	1.00	0.020	0.167	0.10	0.50	2.00	1.00	20.51	0.10	2.55
TTU-56	1.53	1.53	0.00	1.00	0.020	0.167	0.10	0.50	2.00	1.00	20.46	0.10	2.49
TTU-56	1.59	1.59	0.00	1.00	0.020	0.167	0.10	0.50	2.00	1.00	20.67	0.10	2.56
TTU-56	1.25	1.25	0.00	1.00	0.020	0.167	0.10	0.50	2.00	1.00	20.20	0.10	2.40
TTU-56	0.77	0.77	0.00	1.00	0.020	0.167	0.10	0.50	2.00	1.00	20.00	0.10	1.96
TTU-56	1.24	1.24	0.00	1.00	0.020	0.167	0.10	0.50	2.00	1.00	20.00	0.10	2.40

Continued on next page

Table 7: Texas Tech Experimental Performance Data for Drop-Type Inlets — Continued

ID-CODE	Q_A	Q_I	Q_O	Q_R	S_0	S_x	d_a	h_b	L_I	W_I	L_R	W_R	Fr
TTU-57	5.17	3.40	1.78	0.66	0.020	0.167	0.18	0.50	2.00	1.00	10.85	0.18	2.19
TTU-57	5.19	3.42	1.77	0.66	0.020	0.167	0.18	0.50	2.00	1.00	10.85	0.18	2.20
TTU-57	5.18	3.42	1.76	0.66	0.020	0.167	0.18	0.50	2.00	1.00	10.85	0.18	2.19
TTU-57	3.61	2.97	0.64	0.82	0.020	0.167	0.15	0.50	2.00	1.00	13.49	0.15	2.29
TTU-57	3.64	3.06	0.58	0.84	0.020	0.167	0.15	0.50	2.00	1.00	13.47	0.15	2.32
TTU-57	3.65	3.00	0.65	0.82	0.020	0.167	0.15	0.50	2.00	1.00	13.45	0.15	2.33
TTU-57	2.65	2.65	0.00	1.00	0.020	0.167	0.13	0.50	2.00	1.00	15.27	0.13	2.35
TTU-57	2.65	2.65	0.00	1.00	0.020	0.167	0.13	0.50	2.00	1.00	15.27	0.13	2.36
TTU-57	2.75	2.75	0.00	1.00	0.020	0.167	0.13	0.50	2.00	1.00	14.84	0.13	2.34
TTU-57	1.90	1.90	0.00	1.00	0.020	0.167	0.11	0.50	2.00	1.00	18.74	0.11	2.52
TTU-57	1.94	1.94	0.00	1.00	0.020	0.167	0.11	0.50	2.00	1.00	18.82	0.11	2.57
TTU-57	1.96	1.96	0.00	1.00	0.020	0.167	0.11	0.50	2.00	1.00	18.82	0.11	2.60
TTU-58	2.50	0.73	1.77	0.29	0.020	0.167	0.16	0.50	1.00	1.00	6.30	0.16	1.77
TTU-58	2.51	0.74	1.77	0.29	0.020	0.167	0.16	0.50	1.00	1.00	6.43	0.16	1.82
TTU-58	2.45	0.67	1.78	0.27	0.020	0.167	0.16	0.50	1.00	1.00	6.45	0.16	1.79
TTU-58	1.95	0.65	1.30	0.33	0.020	0.167	0.14	0.50	1.00	1.00	7.39	0.14	1.87
TTU-58	1.92	0.63	1.29	0.33	0.020	0.167	0.14	0.50	1.00	1.00	7.33	0.14	1.83
TTU-58	1.88	0.59	1.30	0.31	0.020	0.167	0.14	0.50	1.00	1.00	7.38	0.14	1.84
TTU-58	0.75	0.75	0.00	1.00	0.020	0.167	0.15	0.50	1.00	1.00	6.49	0.15	0.59
TTU-58	0.94	0.94	0.00	1.00	0.020	0.167	0.15	0.50	1.00	1.00	6.62	0.15	0.72
TTU-58	1.00	1.00	0.00	1.00	0.020	0.167	0.15	0.50	1.00	1.00	6.49	0.15	0.79
TTU-59	3.26	1.95	1.31	0.60	0.020	0.167	0.15	0.50	1.00	1.00	6.75	0.15	2.19
TTU-59	3.28	1.95	1.33	0.59	0.020	0.167	0.15	0.50	1.00	1.00	6.76	0.15	2.19
TTU-59	3.34	2.05	1.29	0.61	0.020	0.167	0.15	0.50	1.00	1.00	6.76	0.15	2.22
TTU-59	2.59	1.98	0.61	0.76	0.020	0.167	0.13	0.50	1.00	1.00	7.71	0.13	2.35
TTU-59	2.57	1.93	0.64	0.75	0.020	0.167	0.13	0.50	1.00	1.00	7.69	0.13	2.34
TTU-59	2.55	1.95	0.60	0.77	0.020	0.167	0.13	0.50	1.00	1.00	7.69	0.13	2.32
TTU-59	1.57	1.57	0.00	1.00	0.020	0.167	0.09	0.50	1.00	1.00	10.55	0.09	2.60
TTU-59	1.57	1.57	0.00	1.00	0.020	0.167	0.09	0.50	1.00	1.00	10.55	0.09	2.60
TTU-59	1.56	1.56	0.00	1.00	0.020	0.167	0.09	0.50	1.00	1.00	10.55	0.09	2.59
TTU-60	2.43	0.69	1.74	0.28	0.020	0.167	0.15	0.50	1.00	1.00	6.60	0.15	1.82
TTU-60	2.44	0.71	1.73	0.29	0.020	0.167	0.16	0.50	1.00	1.00	6.42	0.16	1.77
TTU-60	2.49	0.74	1.75	0.30	0.020	0.167	0.16	0.50	1.00	1.00	6.45	0.16	1.81
TTU-60	1.79	0.49	1.30	0.27	0.020	0.167	0.14	0.50	1.00	1.00	7.27	0.14	1.78
TTU-60	1.97	0.68	1.29	0.35	0.020	0.167	0.13	0.50	1.00	1.00	7.52	0.13	1.91
TTU-60	1.94	0.64	1.30	0.33	0.020	0.167	0.14	0.50	1.00	1.00	7.22	0.14	1.87
TTU-60	0.64	0.64	0.00	1.00	0.020	0.167	0.16	0.50	1.00	1.00	6.45	0.16	0.37
TTU-60	0.70	0.70	0.00	1.00	0.020	0.167	0.16	0.50	1.00	1.00	6.45	0.16	0.40
TTU-60	0.62	0.62	0.00	1.00	0.020	0.167	0.16	0.50	1.00	1.00	6.45	0.16	0.36

Continued on next page

Table 7: Texas Tech Experimental Performance Data for Drop-Type Inlets — Continued

ID-CODE	Q_A	Q_I	Q_O	Q_R	S_0	S_x	d_a	h_b	L_I	W_I	L_R	W_R	Fr
TTU-61	3.17	1.69	1.48	0.53	0.020	0.167	0.16	0.50	1.00	1.00	6.08	0.16	1.85
TTU-61	3.20	1.71	1.49	0.53	0.020	0.167	0.15	0.50	1.00	1.00	6.46	0.15	1.93
TTU-61	3.21	1.72	1.49	0.54	0.020	0.167	0.17	0.50	1.00	1.00	6.06	0.17	1.84
TTU-61	2.52	1.97	0.55	0.78	0.020	0.167	0.14	0.50	1.00	1.00	7.39	0.14	2.10
TTU-61	2.51	1.97	0.54	0.78	0.020	0.167	0.14	0.50	1.00	1.00	7.39	0.14	2.09
TTU-61	2.56	2.01	0.54	0.79	0.020	0.167	0.14	0.50	1.00	1.00	7.39	0.14	2.11
TTU-61	1.62	1.62	0.00	1.00	0.020	0.167	0.10	0.50	1.00	1.00	10.10	0.10	2.54
TTU-61	1.64	1.64	0.00	1.00	0.020	0.167	0.10	0.50	1.00	1.00	10.08	0.10	2.58
TTU-61	1.54	1.54	0.00	1.00	0.020	0.167	0.10	0.50	1.00	1.00	10.08	0.10	2.42
TTU-61	1.27	1.27	0.00	1.00	0.020	0.167	0.09	0.50	1.00	1.00	11.03	0.09	2.46
TTU-61	1.29	1.29	0.00	1.00	0.020	0.167	0.09	0.50	1.00	1.00	11.15	0.09	2.48
TTU-61	1.29	1.29	0.00	1.00	0.020	0.167	0.09	0.50	1.00	1.00	11.15	0.09	2.48
TTU-62	3.19	1.19	2.00	0.37	0.020	0.167	0.15	0.00	1.00	1.00	6.88	0.15	2.30
TTU-62	3.21	1.27	1.94	0.40	0.020	0.167	0.15	0.00	1.00	1.00	6.88	0.15	2.32
TTU-62	3.22	1.22	2.00	0.38	0.020	0.167	0.15	0.00	1.00	1.00	6.88	0.15	2.34
TTU-62	2.48	1.15	1.33	0.46	0.020	0.167	0.13	0.00	1.00	1.00	7.71	0.13	2.39
TTU-62	2.51	1.22	1.29	0.49	0.020	0.167	0.13	0.00	1.00	1.00	7.65	0.13	2.37
TTU-62	2.48	1.19	1.29	0.48	0.020	0.167	0.13	0.00	1.00	1.00	7.65	0.13	2.34
TTU-63	3.40	0.91	2.49	0.27	0.020	0.167	0.34	0.00	1.00	1.00	2.96	0.34	1.53
TTU-63	3.31	0.78	2.53	0.24	0.020	0.167	0.33	0.00	1.00	1.00	3.00	0.33	1.55
TTU-63	3.34	0.82	2.52	0.24	0.020	0.167	0.33	0.00	1.00	1.00	3.00	0.33	1.57
TTU-63	2.57	0.74	1.82	0.29	0.020	0.167	0.13	0.00	1.00	1.00	7.71	0.13	2.42
TTU-63	2.58	0.65	1.93	0.25	0.020	0.167	0.13	0.00	1.00	1.00	7.71	0.13	2.43
TTU-63	2.57	0.77	1.80	0.30	0.020	0.167	0.13	0.00	1.00	1.00	7.71	0.13	2.42
TTU-64	3.23	1.30	1.93	0.40	0.020	0.167	0.14	0.00	2.00	1.00	14.08	0.14	2.38
TTU-64	3.24	1.27	1.97	0.39	0.020	0.167	0.14	0.00	2.00	1.00	14.15	0.14	2.36
TTU-64	3.25	1.27	1.98	0.39	0.020	0.167	0.14	0.00	2.00	1.00	14.15	0.14	2.37
TTU-64	2.48	1.22	1.25	0.49	0.020	0.167	0.13	0.00	2.00	1.00	15.75	0.13	2.40
TTU-64	2.55	1.34	1.21	0.52	0.020	0.167	0.13	0.00	2.00	1.00	15.42	0.13	2.39
TTU-64	2.47	1.23	1.24	0.50	0.020	0.167	0.13	0.00	2.00	1.00	15.58	0.13	2.35
TTU-65	3.25	1.85	1.40	0.57	0.020	0.167	0.15	0.00	2.00	1.00	13.61	0.15	2.27
TTU-65	3.25	1.83	1.41	0.56	0.020	0.167	0.15	0.00	2.00	1.00	13.61	0.15	2.27
TTU-65	3.26	1.87	1.39	0.57	0.020	0.167	0.15	0.00	2.00	1.00	13.61	0.15	2.28
TTU-65	2.37	1.46	0.90	0.62	0.020	0.167	0.13	0.00	2.00	1.00	16.00	0.13	2.37
TTU-65	2.36	1.43	0.93	0.61	0.020	0.167	0.13	0.00	2.00	1.00	15.96	0.13	2.38
TTU-65	2.39	1.48	0.91	0.62	0.020	0.167	0.13	0.00	2.00	1.00	16.00	0.13	2.39
TTU-66	3.58	1.75	1.83	0.49	0.020	0.167	0.15	0.50	2.00	1.00	13.40	0.15	2.30
TTU-66	3.60	1.83	1.78	0.51	0.020	0.167	0.15	0.50	2.00	1.00	13.65	0.15	2.33
TTU-66	3.58	1.76	1.82	0.49	0.020	0.167	0.15	0.50	2.00	1.00	13.65	0.15	2.31

Continued on next page

Table 7: Texas Tech Experimental Performance Data for Drop-Type Inlets — Continued

ID-CODE	Q_A	Q_I	Q_O	Q_R	S_0	S_x	d_a	h_b	L_I	W_I	L_R	W_R	Fr
TTU-66	3.08	1.94	1.13	0.63	0.020	0.167	0.14	0.50	2.00	1.00	13.84	0.14	2.28
TTU-66	3.06	2.95	0.11	0.96	0.020	0.167	0.14	0.50	2.00	1.00	13.84	0.14	2.27
TTU-66	3.09	2.97	0.12	0.96	0.020	0.167	0.14	0.50	2.00	1.00	13.84	0.14	2.29
TTU-66	1.83	1.83	0.00	1.00	0.020	0.167	0.11	0.50	2.00	1.00	18.52	0.11	2.46
TTU-66	1.83	1.83	0.00	1.00	0.020	0.167	0.11	0.50	2.00	1.00	18.52	0.11	2.46
TTU-66	1.83	1.83	0.00	1.00	0.020	0.167	0.11	0.50	2.00	1.00	18.52	0.11	2.45
TTU-66	1.39	1.39	0.00	1.00	0.020	0.167	0.10	0.50	2.00	1.00	20.41	0.10	2.40
TTU-66	1.38	1.38	0.00	1.00	0.020	0.167	0.10	0.50	2.00	1.00	20.46	0.10	2.38
TTU-66	1.42	1.42	0.00	1.00	0.020	0.167	0.10	0.50	2.00	1.00	20.46	0.10	2.44
TTU-67	2.24	0.51	1.74	0.23	0.020	0.167	0.15	0.50	2.00	1.00	13.42	0.15	1.75
TTU-67	2.21	0.42	1.79	0.19	0.020	0.167	0.14	0.50	2.00	1.00	13.96	0.14	1.81
TTU-67	2.15	0.51	1.64	0.24	0.020	0.167	0.15	0.50	2.00	1.00	13.40	0.15	1.72
TTU-67	1.78	0.44	1.34	0.25	0.020	0.167	0.14	0.50	2.00	1.00	14.01	0.14	1.65
TTU-67	1.89	0.71	1.18	0.37	0.020	0.167	0.15	0.50	2.00	1.00	13.75	0.15	1.70
TTU-67	1.85	0.52	1.32	0.28	0.020	0.167	0.15	0.50	2.00	1.00	13.58	0.15	1.68
TTU-67	0.68	0.68	0.00	1.00	0.020	0.167	0.12	0.50	2.00	1.00	17.09	0.12	0.84
TTU-67	0.59	0.59	0.00	1.00	0.020	0.167	0.12	0.50	2.00	1.00	17.09	0.12	0.72
TTU-67	0.75	0.75	0.00	1.00	0.020	0.167	0.12	0.50	2.00	1.00	17.09	0.12	0.92
TTU-67	2.24	0.51	1.74	0.23	0.020	0.167	0.15	0.50	1.00	1.00	6.71	0.15	1.75
TTU-67	2.21	0.57	1.64	0.26	0.020	0.167	0.14	0.50	1.00	1.00	6.98	0.14	1.81
TTU-67	2.15	0.36	1.79	0.17	0.020	0.167	0.15	0.50	1.00	1.00	6.70	0.15	1.72
TTU-67	1.76	0.40	1.36	0.23	0.020	0.167	0.13	0.50	1.00	1.00	7.69	0.13	1.78
TTU-67	1.78	0.39	1.40	0.22	0.020	0.167	0.13	0.50	1.00	1.00	7.91	0.13	1.84
TTU-67	1.84	0.46	1.38	0.25	0.020	0.167	0.13	0.50	1.00	1.00	7.91	0.13	1.85
TTU-67	0.33	0.33	0.00	1.00	0.020	0.167	0.16	0.50	1.00	1.00	6.37	0.16	0.17
TTU-67	0.34	0.34	0.00	1.00	0.020	0.167	0.16	0.50	1.00	1.00	6.37	0.16	0.18
TTU-67	0.34	0.34	0.00	1.00	0.020	0.167	0.16	0.50	1.00	1.00	6.37	0.16	0.18
TTU-68	3.05	1.47	1.58	0.48	0.020	0.167	0.17	0.50	1.00	1.00	5.98	0.17	1.88
TTU-68	2.95	1.37	1.58	0.46	0.020	0.167	0.16	0.50	1.00	1.00	6.30	0.16	1.93
TTU-68	2.93	1.35	1.58	0.46	0.020	0.167	0.16	0.50	1.00	1.00	6.17	0.16	1.91
TTU-68	2.10	0.92	1.18	0.44	0.020	0.167	0.14	0.50	1.00	1.00	7.38	0.14	1.93
TTU-68	1.98	0.80	1.18	0.41	0.020	0.167	0.14	0.50	1.00	1.00	7.34	0.14	1.86
TTU-68	2.16	1.01	1.15	0.47	0.020	0.167	0.14	0.50	1.00	1.00	7.37	0.14	1.97
TTU-68	1.18	1.18	0.00	1.00	0.020	0.167	0.10	0.50	1.00	1.00	10.20	0.10	2.13
TTU-68	1.21	1.21	0.00	1.00	0.020	0.167	0.10	0.50	1.00	1.00	10.20	0.10	2.21
TTU-68	1.19	1.19	0.00	1.00	0.020	0.167	0.10	0.50	1.00	1.00	10.14	0.10	2.18
TTU-68	1.48	1.48	0.00	1.00	0.020	0.167	0.10	0.50	1.00	1.00	10.39	0.10	2.51
TTU-68	1.44	1.44	0.00	1.00	0.020	0.167	0.10	0.50	1.00	1.00	10.28	0.10	2.48
TTU-68	1.44	1.44	0.00	1.00	0.020	0.167	0.10	0.50	1.00	1.00	10.28	0.10	2.48

Continued on next page

Table 7: Texas Tech Experimental Performance Data for Drop-Type Inlets — Continued

ID-CODE	Q_A	Q_I	Q_O	Q_R	S_0	S_x	d_a	h_b	L_I	W_I	L_R	W_R	Fr
TTU-69	3.62	1.26	2.36	0.35	0.020	0.167	0.14	0.00	1.00	1.00	7.04	0.14	2.51
TTU-69	3.64	1.29	2.35	0.35	0.020	0.167	0.14	0.00	1.00	1.00	7.04	0.14	2.52
TTU-69	3.64	1.32	2.32	0.36	0.020	0.167	0.14	0.00	1.00	1.00	7.04	0.14	2.53
TTU-69	2.80	1.41	1.39	0.50	0.020	0.167	0.13	0.00	1.00	1.00	7.50	0.13	2.45
TTU-69	2.79	1.33	1.46	0.48	0.020	0.167	0.13	0.00	1.00	1.00	7.50	0.13	2.44
TTU-69	2.82	1.41	1.41	0.50	0.020	0.167	0.13	0.00	1.00	1.00	7.50	0.13	2.47
TTU-70	3.06	1.14	1.92	0.37	0.020	0.167	0.13	0.00	1.00	1.00	7.67	0.13	2.58
TTU-70	3.08	0.85	2.22	0.28	0.020	0.167	0.13	0.00	1.00	1.00	7.69	0.13	2.58
TTU-70	3.05	1.02	2.03	0.33	0.020	0.167	0.13	0.00	1.00	1.00	7.69	0.13	2.55
TTU-70	2.45	0.54	1.91	0.22	0.020	0.167	0.14	0.00	1.00	1.00	7.28	0.14	2.23
TTU-70	2.49	0.60	1.90	0.24	0.020	0.167	0.14	0.00	1.00	1.00	7.33	0.14	2.25
TTU-70	2.51	0.60	1.91	0.24	0.020	0.167	0.14	0.00	1.00	1.00	7.35	0.14	2.26
TTU-71	3.12	0.49	2.64	0.16	0.020	0.167	0.15	0.00	2.00	1.00	13.19	0.15	2.17
TTU-71	3.18	0.49	2.69	0.15	0.020	0.167	0.15	0.00	2.00	1.00	13.22	0.15	2.20
TTU-71	3.22	0.49	2.72	0.15	0.020	0.167	0.15	0.00	2.00	1.00	13.19	0.15	2.24
TTU-71	2.37	0.44	1.92	0.19	0.020	0.167	0.14	0.00	2.00	1.00	14.56	0.14	2.05
TTU-71	2.08	0.11	1.96	0.05	0.020	0.167	0.13	0.00	2.00	1.00	14.93	0.13	1.92
TTU-71	2.17	0.23	1.94	0.11	0.020	0.167	0.14	0.00	2.00	1.00	14.46	0.14	1.89
TTU-71	3.43	1.63	1.80	0.48	0.020	0.167	0.16	0.00	2.00	1.00	12.66	0.16	2.12
TTU-72	3.32	1.54	1.78	0.46	0.020	0.167	0.16	0.00	2.00	1.00	12.74	0.16	2.00
TTU-72	3.80	2.02	1.78	0.53	0.020	0.167	0.16	0.00	2.00	1.00	12.71	0.16	2.32
TTU-72	2.55	1.48	1.07	0.58	0.020	0.167	0.13	0.00	2.00	1.00	15.46	0.13	2.40
TTU-72	2.83	1.77	1.06	0.62	0.020	0.167	0.14	0.00	2.00	1.00	14.39	0.14	2.36
TTU-72	2.86	1.79	1.07	0.63	0.020	0.167	0.14	0.00	2.00	1.00	14.39	0.14	2.38
TTU-73	3.91	2.15	1.76	0.55	0.020	0.167	0.18	0.50	2.00	2.00	11.41	0.09	1.91
TTU-73	3.81	2.02	1.79	0.53	0.020	0.167	0.18	0.50	2.00	2.00	11.25	0.09	1.85
TTU-73	3.88	2.11	1.78	0.54	0.020	0.167	0.19	0.50	2.00	2.00	10.59	0.09	1.78
TTU-73	3.06	1.87	1.20	0.61	0.020	0.167	0.17	0.50	2.00	2.00	12.05	0.08	1.77
TTU-73	3.23	2.03	1.20	0.63	0.020	0.167	0.17	0.50	2.00	2.00	11.96	0.08	1.87
TTU-73	3.21	2.00	1.21	0.62	0.020	0.167	0.17	0.50	2.00	2.00	11.92	0.08	1.84
TTU-73	2.09	2.09	0.00	1.00	0.020	0.167	0.12	0.50	2.00	2.00	16.43	0.06	2.27
TTU-73	2.13	2.13	0.00	1.00	0.020	0.167	0.12	0.50	2.00	2.00	16.53	0.06	2.31
TTU-73	2.12	2.12	0.00	1.00	0.020	0.167	0.12	0.50	2.00	2.00	16.53	0.06	2.28
TTU-73	1.37	1.37	0.00	1.00	0.020	0.167	0.10	0.50	2.00	2.00	20.25	0.05	2.25
TTU-73	1.35	1.35	0.00	1.00	0.020	0.167	0.10	0.50	2.00	2.00	20.30	0.05	2.22
TTU-73	1.35	1.35	0.00	1.00	0.020	0.167	0.10	0.50	2.00	2.00	20.36	0.05	2.21
TTU-74	3.58	2.10	1.48	0.59	0.020	0.167	0.15	0.50	2.00	2.00	13.49	0.07	2.35
TTU-74	3.61	2.13	1.48	0.59	0.020	0.167	0.15	0.50	2.00	2.00	13.49	0.07	2.37
TTU-74	3.60	2.11	1.49	0.59	0.020	0.167	0.15	0.50	2.00	2.00	13.51	0.07	2.37

Continued on next page

Table 7: Texas Tech Experimental Performance Data for Drop-Type Inlets — Continued

ID-CODE	Q_A	Q_I	Q_O	Q_R	S_0	S_x	d_a	h_b	L_I	W_I	L_R	W_R	Fr
TTU-74	2.95	2.03	0.92	0.69	0.020	0.167	0.14	0.50	2.00	2.00	14.63	0.07	2.38
TTU-74	2.98	2.09	0.89	0.70	0.020	0.167	0.14	0.50	2.00	2.00	14.41	0.07	2.35
TTU-74	2.96	2.05	0.91	0.69	0.020	0.167	0.14	0.50	2.00	2.00	14.63	0.07	2.38
TTU-74	1.88	1.88	0.00	1.00	0.020	0.167	0.11	0.50	2.00	2.00	17.70	0.06	2.33
TTU-74	2.02	2.02	0.00	1.00	0.020	0.167	0.11	0.50	2.00	2.00	17.43	0.06	2.45
TTU-74	2.00	2.00	0.00	1.00	0.020	0.167	0.11	0.50	2.00	2.00	17.74	0.06	2.47
TTU-74	1.98	1.98	0.00	1.00	0.020	0.167	0.11	0.50	2.00	2.00	17.43	0.06	2.40
TTU-74	2.02	2.02	0.00	1.00	0.020	0.167	0.11	0.50	2.00	2.00	17.43	0.06	2.44
TTU-74	2.03	2.03	0.00	1.00	0.020	0.167	0.11	0.50	2.00	2.00	17.47	0.06	2.44
TTU-75	5.07	3.67	1.40	0.72	0.020	0.167	0.18	0.50	2.00	2.00	11.28	0.09	2.26
TTU-75	5.23	3.83	1.40	0.73	0.020	0.167	0.18	0.50	2.00	2.00	11.10	0.09	2.25
TTU-75	5.31	3.90	1.41	0.74	0.020	0.167	0.18	0.50	2.00	2.00	11.10	0.09	2.28
TTU-75	6.11	5.20	0.91	0.85	0.020	0.167	0.27	0.50	2.00	2.00	7.31	0.14	1.77
TTU-75	4.40	3.47	0.93	0.79	0.020	0.167	0.17	0.50	2.00	2.00	11.98	0.08	2.31
TTU-75	4.39	3.46	0.93	0.79	0.020	0.167	0.17	0.50	2.00	2.00	11.98	0.08	2.30
TTU-75	3.56	3.56	0.00	1.00	0.020	0.167	0.15	0.50	2.00	2.00	13.61	0.07	2.41
TTU-75	3.58	3.58	0.00	1.00	0.020	0.167	0.15	0.50	2.00	2.00	13.58	0.07	2.43
TTU-75	3.57	3.57	0.00	1.00	0.020	0.167	0.15	0.50	2.00	2.00	13.58	0.07	2.42
TTU-75	2.57	2.57	0.00	1.00	0.020	0.167	0.13	0.50	2.00	2.00	15.66	0.06	2.39
TTU-75	2.56	2.56	0.00	1.00	0.020	0.167	0.13	0.50	2.00	2.00	15.59	0.06	2.40
TTU-75	2.59	2.59	0.00	1.00	0.020	0.167	0.13	0.50	2.00	2.00	15.66	0.06	2.42
TTU-76	5.06	3.60	1.46	0.71	0.020	0.167	0.17	0.50	2.00	2.00	11.53	0.09	2.22
TTU-76	5.20	3.66	1.53	0.70	0.020	0.167	0.18	0.50	2.00	2.00	11.32	0.09	2.20
TTU-76	5.25	3.87	1.39	0.74	0.020	0.167	0.18	0.50	2.00	2.00	11.32	0.09	2.24
TTU-76	4.22	3.52	0.69	0.84	0.020	0.167	0.15	0.50	2.00	2.00	13.01	0.08	2.34
TTU-76	4.21	3.20	1.00	0.76	0.020	0.167	0.16	0.50	2.00	2.00	12.88	0.08	2.30
TTU-76	4.26	3.50	0.75	0.82	0.020	0.167	0.16	0.50	2.00	2.00	12.86	0.08	2.33
TTU-76	2.77	2.77	0.00	1.00	0.020	0.167	0.13	0.50	2.00	2.00	15.12	0.07	2.38
TTU-76	2.79	2.79	0.00	1.00	0.020	0.167	0.13	0.50	2.00	2.00	15.12	0.07	2.40
TTU-76	2.78	2.78	0.00	1.00	0.020	0.167	0.13	0.50	2.00	2.00	15.12	0.07	2.39
TTU-76	1.80	1.80	0.00	1.00	0.020	0.167	0.11	0.50	2.00	2.00	18.43	0.05	2.45
TTU-76	1.79	1.79	0.00	1.00	0.020	0.167	0.11	0.50	2.00	2.00	18.43	0.05	2.43
TTU-76	1.79	1.79	0.00	1.00	0.020	0.167	0.11	0.50	2.00	2.00	18.43	0.05	2.44
TTU-77	3.38	1.22	2.15	0.36	0.020	0.167	0.17	0.50	2.00	2.00	11.51	0.09	1.76
TTU-77	3.48	1.43	2.04	0.41	0.020	0.167	0.17	0.50	2.00	2.00	11.49	0.09	1.78
TTU-77	3.27	1.10	2.17	0.34	0.020	0.167	0.17	0.50	2.00	2.00	11.94	0.08	1.79
TTU-77	2.23	0.77	1.45	0.35	0.020	0.167	0.16	0.50	2.00	2.00	12.84	0.08	1.63
TTU-77	2.24	0.83	1.41	0.37	0.020	0.167	0.15	0.50	2.00	2.00	13.61	0.07	1.72
TTU-77	2.34	0.91	1.43	0.39	0.020	0.167	0.15	0.50	2.00	2.00	13.61	0.07	1.75

Continued on next page

Table 7: Texas Tech Experimental Performance Data for Drop-Type Inlets — Continued

ID-CODE	Q_A	Q_I	Q_O	Q_R	S_0	S_x	d_a	h_b	L_I	W_I	L_R	W_R	Fr
TTU-77	0.63	0.63	0.00	1.00	0.020	0.167	0.15	0.50	2.00	2.00	13.42	0.07	0.44
TTU-77	0.46	0.46	0.00	1.00	0.020	0.167	0.13	0.50	2.00	2.00	15.87	0.06	0.41
TTU-77	0.47	0.47	0.00	1.00	0.020	0.167	0.12	0.50	2.00	2.00	16.13	0.06	0.43
TTU-78	2.47	0.68	1.78	0.28	0.020	0.167	0.15	0.50	2.00	2.00	13.16	0.08	1.74
TTU-78	2.52	0.75	1.77	0.30	0.020	0.167	0.15	0.50	2.00	2.00	13.16	0.08	1.77
TTU-78	2.44	0.68	1.76	0.28	0.020	0.167	0.15	0.50	2.00	2.00	13.16	0.08	1.74
TTU-78	2.15	0.76	1.39	0.35	0.020	0.167	0.15	0.50	2.00	2.00	13.27	0.08	1.70
TTU-78	54.97	53.58	1.39	0.97	0.020	0.167	3.18	0.50	2.00	2.00	0.63	1.59	0.37
TTU-78	2.15	0.75	1.40	0.35	0.020	0.167	0.15	0.50	2.00	2.00	12.99	0.08	1.68
TTU-78	0.97	0.97	0.00	1.00	0.020	0.167	0.20	0.50	2.00	2.00	9.85	0.10	0.34
TTU-78	0.79	0.79	0.00	1.00	0.020	0.167	0.19	0.50	2.00	2.00	10.47	0.10	0.30
TTU-78	0.75	0.75	0.00	1.00	0.020	0.167	0.19	0.50	2.00	2.00	10.47	0.10	0.29
TTU-79	3.02	0.87	2.15	0.29	0.020	0.167	0.14	0.00	2.00	2.00	14.08	0.07	2.35
TTU-79	3.00	0.86	2.14	0.29	0.020	0.167	0.14	0.00	2.00	2.00	14.08	0.07	2.34
TTU-79	2.97	0.84	2.12	0.28	0.020	0.167	0.14	0.00	2.00	2.00	14.08	0.07	2.30
TTU-79	2.12	0.56	1.56	0.26	0.020	0.167	0.12	0.00	2.00	2.00	16.39	0.06	2.30
TTU-79	2.13	0.59	1.54	0.28	0.020	0.167	0.12	0.00	2.00	2.00	16.39	0.06	2.31
TTU-79	2.18	0.61	1.56	0.28	0.020	0.167	0.12	0.00	2.00	2.00	16.53	0.06	2.33
TTU-80	3.91	1.89	2.02	0.48	0.020	0.167	0.15	0.00	2.00	2.00	13.36	0.07	2.41
TTU-80	3.89	1.86	2.03	0.48	0.020	0.167	0.15	0.00	2.00	2.00	13.36	0.07	2.39
TTU-80	3.82	1.78	2.03	0.47	0.020	0.167	0.15	0.00	2.00	2.00	13.36	0.07	2.34
TTU-80	3.18	1.97	1.21	0.62	0.020	0.167	0.14	0.00	2.00	2.00	14.39	0.07	2.36
TTU-80	3.19	1.99	1.20	0.62	0.020	0.167	0.14	0.00	2.00	2.00	14.39	0.07	2.37
TTU-80	3.22	1.98	1.23	0.62	0.020	0.167	0.14	0.00	2.00	2.00	14.39	0.07	2.39
TTU-81	4.97	3.48	1.49	0.70	0.020	0.167	0.18	0.00	2.00	2.00	11.32	0.09	2.28
TTU-81	5.09	3.60	1.49	0.71	0.020	0.167	0.18	0.00	2.00	2.00	11.09	0.09	2.27
TTU-81	4.97	3.48	1.49	0.70	0.020	0.167	0.18	0.00	2.00	2.00	11.30	0.09	2.29
TTU-81	4.22	3.06	1.16	0.72	0.020	0.167	0.16	0.00	2.00	2.00	12.58	0.08	2.35
TTU-81	4.26	3.12	1.15	0.73	0.020	0.167	0.16	0.00	2.00	2.00	12.58	0.08	2.38
TTU-81	4.26	3.04	1.22	0.71	0.020	0.167	0.16	0.00	2.00	2.00	12.58	0.08	2.38
TTU-82	6.55	5.52	1.02	0.84	0.020	0.167	0.21	0.50	4.00	2.00	19.29	0.10	2.16
TTU-82	6.61	5.58	1.03	0.84	0.020	0.167	0.21	0.50	4.00	2.00	19.29	0.10	2.18
TTU-82	6.66	5.62	1.04	0.84	0.020	0.167	0.21	0.50	4.00	2.00	19.29	0.10	2.20
TTU-82	4.03	4.03	0.00	1.00	0.020	0.167	0.15	0.50	4.00	2.00	26.32	0.08	2.42
TTU-82	3.80	3.80	0.00	1.00	0.020	0.167	0.15	0.50	4.00	2.00	27.03	0.07	2.39
TTU-82	3.86	3.86	0.00	1.00	0.020	0.167	0.15	0.50	4.00	2.00	27.03	0.07	2.43
TTU-83	3.69	2.10	1.59	0.57	0.020	0.167	0.15	0.50	4.00	2.00	27.33	0.07	2.41
TTU-83	3.69	2.05	1.64	0.55	0.020	0.167	0.15	0.50	4.00	2.00	27.33	0.07	2.42
TTU-83	3.67	2.01	1.65	0.55	0.020	0.167	0.15	0.50	4.00	2.00	27.33	0.07	2.40

Continued on next page

Table 7: Texas Tech Experimental Performance Data for Drop-Type Inlets — Continued

ID-CODE	Q_A	Q_I	Q_O	Q_R	S_0	S_x	d_a	h_b	L_I	W_I	L_R	W_R	Fr
TTU-83	2.21	2.21	0.00	1.00	0.020	0.167	0.12	0.50	4.00	2.00	32.97	0.06	2.38
TTU-83	2.23	2.23	0.00	1.00	0.020	0.167	0.12	0.50	4.00	2.00	32.97	0.06	2.41
TTU-83	2.27	2.27	0.00	1.00	0.020	0.167	0.12	0.50	4.00	2.00	32.97	0.06	2.44
TTU-84	2.22	0.58	1.64	0.26	0.020	0.167	0.12	0.50	4.00	2.00	33.33	0.06	2.35
TTU-84	2.22	0.54	1.69	0.24	0.020	0.167	0.12	0.50	4.00	2.00	33.33	0.06	2.35
TTU-84	2.33	0.71	1.63	0.30	0.020	0.167	0.12	0.50	4.00	2.00	33.33	0.06	2.47
TTU-84	0.90	0.90	0.00	1.00	0.020	0.167	0.14	0.50	4.00	2.00	28.17	0.07	0.62
TTU-84	1.22	1.22	0.00	1.00	0.020	0.167	0.14	0.50	4.00	2.00	28.17	0.07	0.84
TTU-84	1.34	1.34	0.00	1.00	0.020	0.167	0.14	0.50	4.00	2.00	28.17	0.07	0.92

11 Appendix-IV Relevant Charts for Inlet Design.

This appendix contains various charts from HEC-22 (unless otherwise indicated) relevant to inlet design. The charts in this appendix are for U.S. Customary Units only. SI charts are available in HEC-22.

The charts in this document are:

1. Chart 5B. Used to compute frontal flow interception efficiency for a grated inlet.
2. Chart 6B. Used to compute side flow interception efficiency for a grated inlet.
3. Chart 9B. Used to compute inlet capture capacity in a sump (sag) condition. Lower left portion implements a weir equation; upper right portion is an orifice equation.
4. Chart 14B. Used to determine flow depth in a trapezoidal channel.
5. Chart 14BM. Same as chart 14B but with the Qn axis extended one additional log cycle for very shallow flow considerations.

CHART 5B

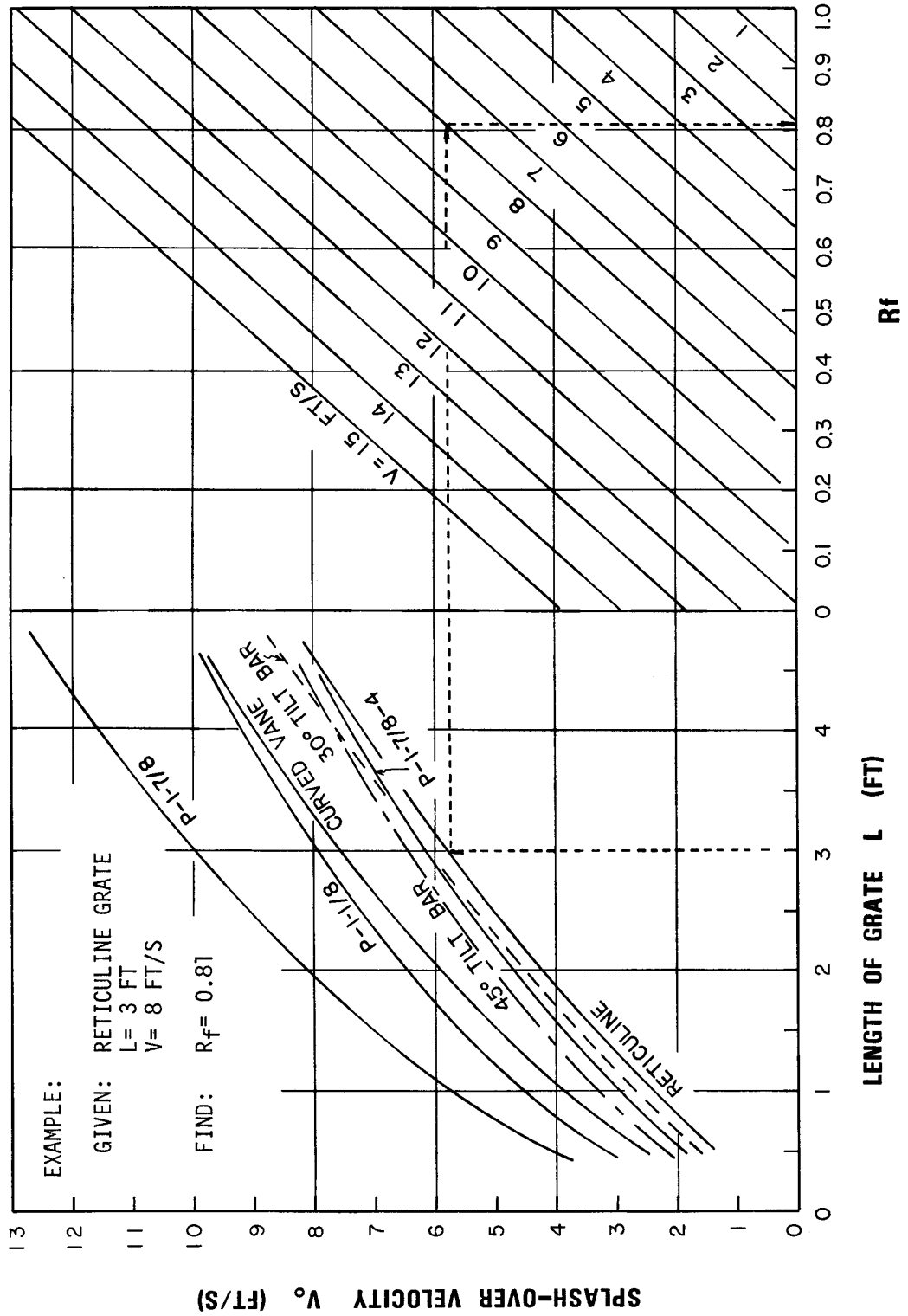
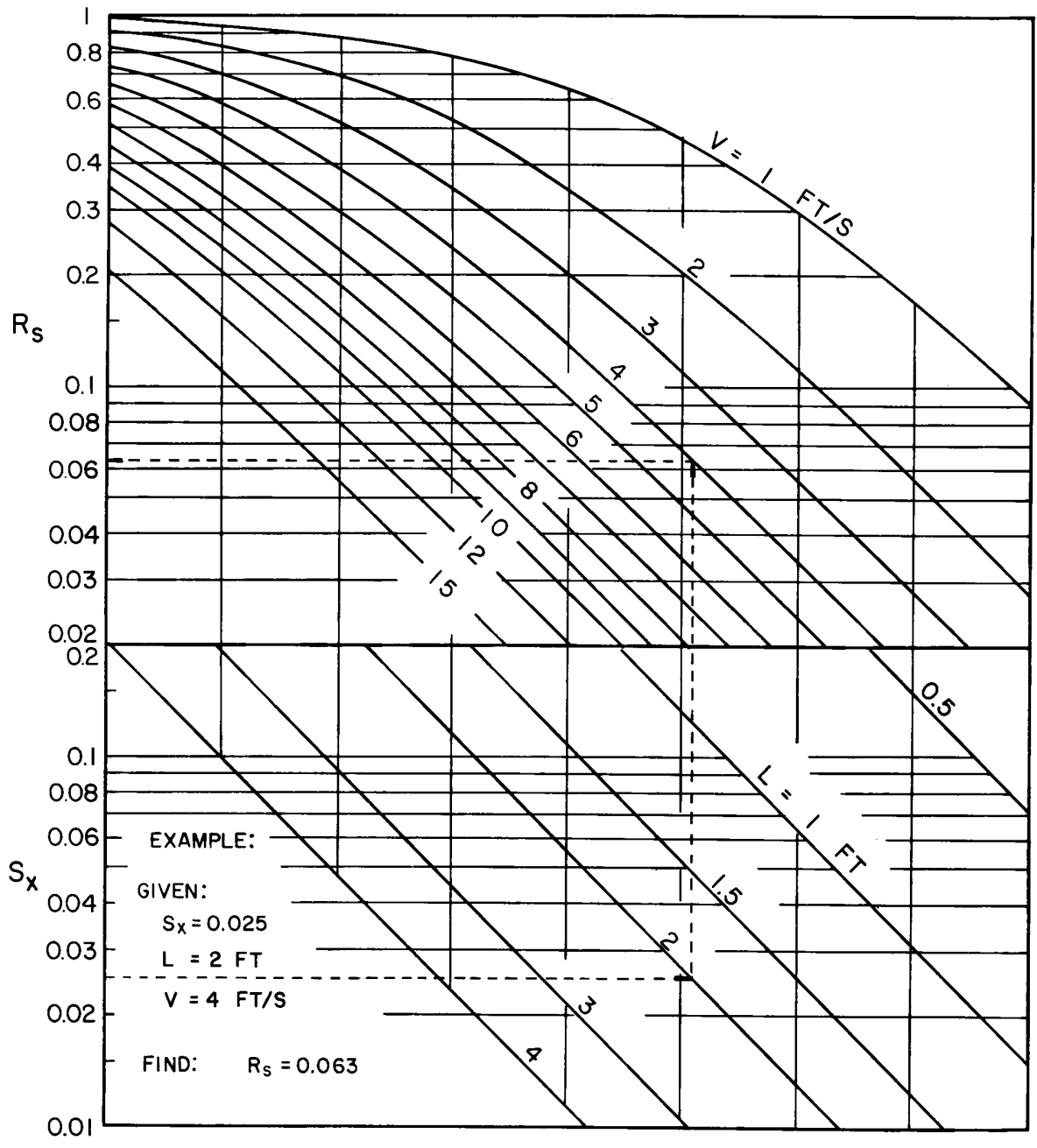
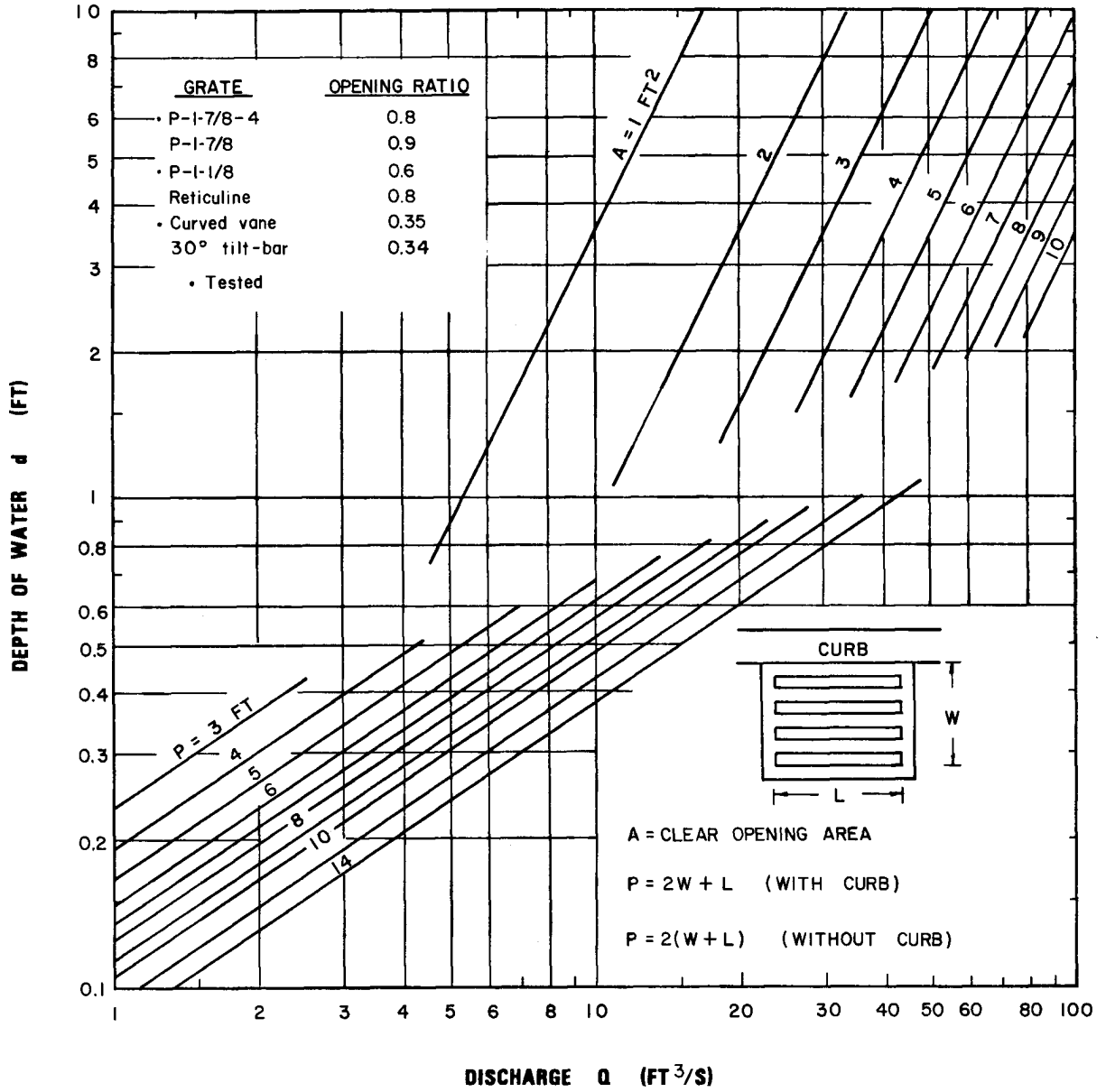

CHART 6B



Grate Inlet Side Flow Intercept Efficiency

CHART 9B



Grate Inlet Capacity in Sump Conditions - English Units

CHART 14B

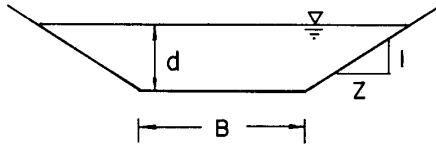

NOTE: Project horizontally from Z=0 scale to obtain values for Z=1 to 6

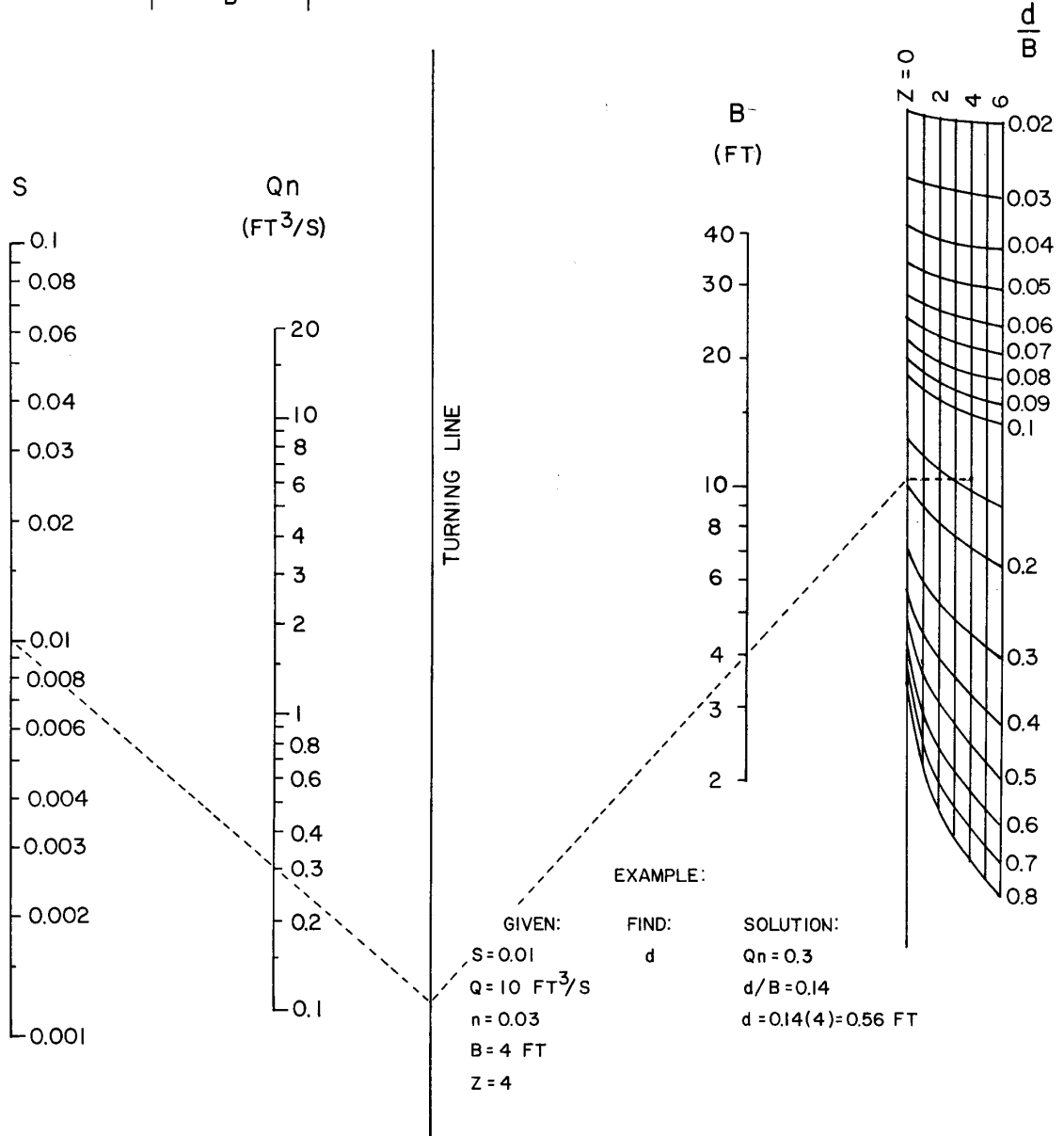

Solution to Manning's Equation for Channels of Various Side Slopes - English Units

CHART 14B

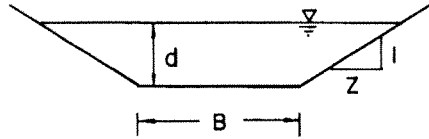

NOTE: Project horizontally from Z=0 scale to obtain values for Z=1 to 6

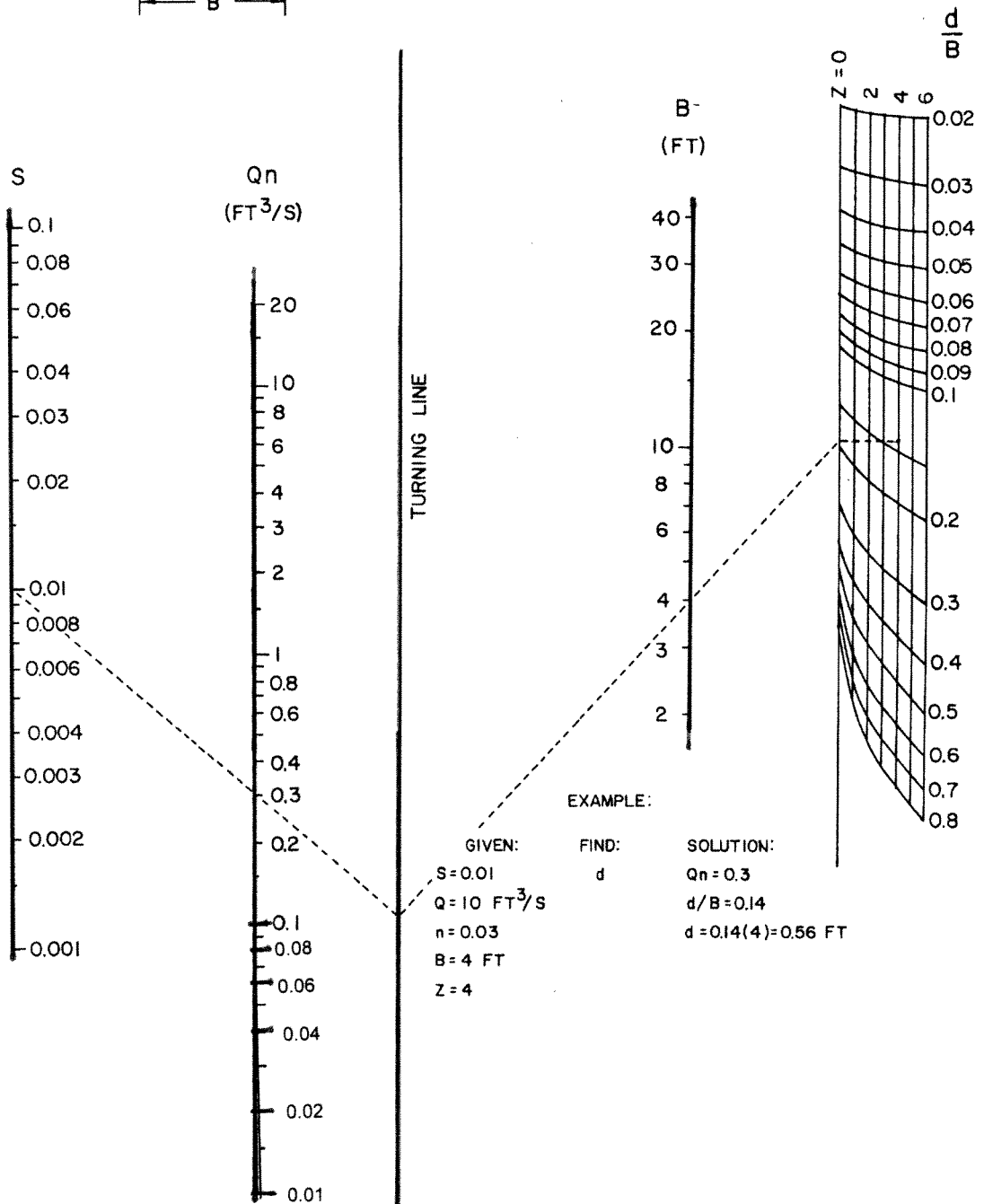

Solution to Manning's Equation for Channels of Various Side Slopes - English Units

Qn axis extrapolated one additional log-cycle to accommodate shallow flow as observed in laboratory experiments.